

UNCLASSIFIED

AD NUMBER	
AD397653	
CLASSIFICATION CHANGES	
TO:	unclassified
FROM:	confidential
LIMITATION CHANGES	
TO:	Approved for public release, distribution unlimited
FROM:	Distribution: Further dissemination only as directed by Naval Research Laboratory, Washington, DC, 30 SEP 1955, or higher DoD authority.
AUTHORITY	
30 Sep 1967, DoDD 5200.10; NRL ltr dtd 14 May 1971	

THIS PAGE IS UNCLASSIFIED

SECURITY

MARKING

The classified or limited status of this report applies to each page, unless otherwise marked.

Separate page printouts MUST be marked accordingly.

THIS DOCUMENT CONTAINS INFORMATION AFFECTING THE NATIONAL DEFENSE OF THE UNITED STATES WITHIN THE MEANING OF THE ESPIONAGE LAWS, TITLE 18, U.S.C., SECTIONS 793 AND 794. THE TRANSMISSION OR THE REVELATION OF ITS CONTENTS IN ANY MANNER TO AN UNAUTHORIZED PERSON IS PROHIBITED BY LAW.

NOTICE: When government or other drawings, specifications or other data are used for any purpose other than in connection with a definitely related government procurement operation, the U. S. Government thereby incurs no responsibility, nor any obligation whatsoever; and the fact that the Government may have formulated, furnished, or in any way supplied the said drawings, specifications, or other data is not to be regarded by implication or otherwise as in any manner licensing the holder or any other person or corporation, or conveying any rights or permission to manufacture, use or sell any patented invention that may in any way be related thereto.

**Best
Available
Copy**

738

CONFIDENTIAL

(Handwritten circle)

UNANNOUNCED

653

397

**AD NO. —
DDG FILE COPY**

Defense Documentation Center

Defense Supply Agency

Cameron Station • Alexandria, Virginia

**DDC
REGISTRATION
APR 27 1967**
(Handwritten initials)



CONFIDENTIAL

397 653

AD No. [REDACTED]

ASTIA FILE COPY

CONFIDENTIAL

NRL Memorandum Report 527

**QUANTITATIVE MEASUREMENTS OF RADAR
ECHOES FROM AIRCRAFT XIII. F2H-2B**

F. C. Macdonald
ELECTRONICS DIVISION

FC

30 September 1955



NAVAL RESEARCH LABORATORY
Washington, D.C.

CONFIDENTIAL

DEC 7 1955

55 AA

56648

Further distribution of this report, or of an abstract,
or reproduction thereof may be made only with the approval
of the Classified Material Control Officer, Naval Research
Laboratory, Washington 25, D. C., or of the activity
concerning the research reported therein as appropriate.

CONFIDENTIAL

(14) NRL-MR-527

6:18 5/11
5:11 5/11

(6) QUANTITATIVE MEASUREMENTS OF RADAR ECHOES
FROM AIRCRAFT.
XIII. F2H-2B [U] (8)

(9) Memorandum rept.

(10) F. C. Macdonald

(11) 30 September 1955

CLASSIFIED AT 5 YEAR INTERVALS;
DECLASSIFIED AT 12 YEARS
EXCEPT WHERE SHOWN OTHERWISE

Wave-Propagation Branch
Electronic Division
Naval Research Laboratory
Washington 25, D. C.

(12) 747.1

251 950

CONFIDENTIAL

(16) NR-502220,
NR-682-010

mt

contains information affecting the National
Defense which, if disclosed, could result in the
identification of the source of the information
and could be prejudicial to the national
defense.

55 33348

gd

CONFIDENTIAL

DISTRIBUTION

CNO		
Attn: Op-03D		1
Attn: Op-42		1
Attn: Op-342E		1
Attn: Op-374		2
ANAF/GM Mailing List, Part A		88
ONR		
Attn: Code 427		1
Attn: Code 459		1
Attn: Code 470		1
BuAer		
Attn: El-43		5
Attn: El-80		1
BuOrd		
Attn: Re4f		1
BuShips		
Attn: Code 801		1
Attn: Code 820		1
Attn: Code 821		5
Attn: Code 835		1
ComOpDevFor		1
ComFair, Whidbey		1
Attn: LCDR J. W. Holcomb		
WSEG		2
CO, NATC, Patuxent River, Md.		
Attn: NANEP (CDR Rodman)		2
Attn: CO, VW-2		1
CO and Dir., USNEL		2
Attn: Code 2744m		1
OCSigO		
Attn: Ch., Eng. and Tech. Div. SIGTM-S		1
CO, SCEL		
Attn: Dir. of Eng.		2

CONFIDENTIAL

CONFIDENTIAL

CO, Rome Air Development Center Attn: ENR	1
CO, Wright Air Development Center Attn: Air Tech. Int. Center (Col. Johnston) Attn: WCLRD2	1 2
CO, Air Force Cambridge Research Center Attn: ERRS	1
O/C, NOEU, National BuStds Attn: CRPL	1
Asst. Sec. of Defense (R-D) Attn: Technical Library Branch	2
BJSM (Navy Staff)	1
BJSM (Army Staff)	1
BJSM (Air Staff)	1
Canadian Joint Staff Attn: Navy Member	5
Australian Joint Service Staff	5
ASRE, England	1
DRE, Admiralty, England	1
Ministry of Supply, England	1
RRDE, England	1
TRE, England	1

CONFIDENTIAL

CONFIDENTIAL

ABSTRACT

The radar target characteristics (radar area) of the F2H-2B aircraft are described quantitatively for radar frequencies of 115, 215, 1250, and 2813 Mc.. The radar area is greater at the lower frequencies (115 and 215 Mc.) than at the higher frequencies (2813 and 1250 Mc.). With large samples of azimuth aspect and with equal weights given to equal aspect intervals, the average radar area at 115 Mc. is about six times greater than the average radar area at 2813 Mc. The probability that the radar area corresponding to a particular aircraft aspect will lie in a given 1 db interval is normally distributed. Over a wide range of aspects, the probability distribution of single pulse amplitudes is essentially equal to the distribution of median pulse amplitudes, where the medians are obtained from samples of length 1/12 second (for 2813 and 1250 Mc.), 1/2 second (for 215 Mc.), and 8 seconds (for 115 Mc.). The radar area for the two lower frequencies is given as a continuous function of aircraft aspect while the data for the two higher frequencies are given in the form of probability distributions.

PROBLEM STATUS

This is an interim report on the problem; work continues.

AUTHORIZATION

NRL Problems: R02-06 (NR 502220)
R02-10 (NR 682-010)
R07-04 (NR 687-040)

CONFIDENTIAL

CONFIDENTIAL

INTRODUCTION

The work described in this report was carried out to determine the optimum manner (least chance of detection) in which U. S. aircraft should approach an enemy area guarded by radar. This report, on one phase of this overall problem, through the presentation of the probability of occurrence of radar area, allows the computation of the probability of detection of certain aircraft by radar operating on several frequencies.

The measurement program included the F2H-2B, AJ-1, AB-4B, and FJ-2 aircraft.¹ These aircraft were flown with the courses, altitudes and flight attitudes calculated to simulate, as closely as possible, the range of aircraft aspects observed by a ground-based search radar with the aircraft at normal combat altitude and speed. Simultaneous measurements were made at radar frequencies of 2813, 1250, 215, and 115 Mc.² This report includes only the data on the F2H-2B, a jet aircraft which carried wing-tip gas tanks and a T-63 shape (simulated Mark VII bomb) under the port wing root. Pictures of the plane appear in Fig. 1.

Radar area, σ , as used in this report, is defined, if the target is in free space³, by the equation,

$$\sigma = P_R(4\pi)^3 R^4 / P_T(G\lambda)^2$$

1. Although measurements were also requested for the F7U-3 and A3D aircraft, they were not made available for the measurement program.
2. These frequencies were the nearest available to the requested frequencies of 2860, 1200, 200, and 73 Mc.
3. If not in free space (i.e., ground reflected energy reaches the target) this equation is modified by a term depending upon antenna beam shape, height of radar antenna, altitude and range of target, reflection coefficient of the ground, and radar wavelength.

CONFIDENTIAL

CONFIDENTIAL

in which P_R = received power, R = range of target, P_T = transmitter power, G = antenna gain, and λ = radar wavelength. To convert the received power, P_R , into quantitative values of radar area, σ , the radar must be calibrated or standardized. Two methods of calibration were used in this work. The first of these methods, the method of radar parameters, has been described by Katzin⁴. The second method, the standard target method, requires placing in the field of the radar a target of known radar area (sphere, corner, sheet) and comparing the amplitude of its echo with the radar echo. It was possible to use both of these methods at 2813 and 1250 Mc, but only the standard target method could be used at the two lower frequencies. These methods and their effect upon the accuracy of the data in this report are discussed in Appendix I.

The low frequency (115 and 215 Mc) data were slowly varying functions of aircraft aspect and it was possible to plot radar area as a continuous function of aspect.

The high-frequency (1250-2813 Mc) data are divided into twenty-second samples for which the probability that the radar area equals or exceeds certain discrete levels is tabulated. A particular probability distribution is usually not repeatable but the data show, by comparing data from different flights, that the probability of occurrence of a radar area lying in a given 1-db interval is approximately normally distributed.

An increase of radar area with radar wavelength is observed in the

4. Katzin, Martin, "Quantitative Radar Measurements," Proc. I.R.E., Vol. 35, No. 11, November, 1947.

CONFIDENTIAL

CONFIDENTIAL

data, the increase being about six-to-one from the shortest to the longest wavelength.

METHODS OF MEASUREMENT

A series of flights was planned, so that while the aircraft was between the ranges of 8 and 11 miles from the radar, it would present to the radar one of the following azimuthal aspects (defined in Fig. 2): 0°, 5°, 10°, 15°, 20°, 30°, 90°, 180°, 135°, 190°, 195°, 200°, 210°, and 270°. (The data were taken in the 8-11 mile region since here a maximum of the interference pattern occurs for both 115 and 215 Mc. and the desired elevation aspect is obtained.) All flights were "straight and level," at an altitude of 2700 feet. The pilot was instructed to hold the aircraft's angle of attack equal to that at normal combat altitude and speed and to hold the requested heading during all of each run (i.e., not necessarily to fly along a particular ground track). With the aircraft flown in this manner, and knowing the range, elevation angle, and azimuth angle to the aircraft from the radar, it was possible to determine aircraft aspect.

The aircraft echoes were recorded photographically by two different methods:

1) A movie camera photographed each A-scope presentation with one-half second exposures every second. In addition to revealing the presence of interfering echoes, this record of superimposed A-scope traces gave a compressed version of the echo behavior.

2) The aircraft video echo was gated from the total video and presented on an oscilloscope which was photographed on a continuously

CONFIDENTIAL

CONFIDENTIAL

moving film. This record permitted a pulse-by-pulse analysis of the echo behavior and is the record from which most of the data in this report are derived.⁵

In addition to these two records, a data board containing such information as time, range, elevation angle, and azimuth angle was photographed by a third camera. Timing marks on each film permitted correlation of all records.

RESULTS

Low Frequency (115 and 215 Mc.).

Two related features are prominent in the low frequency data:

(1) the A-scope records contain practically as much information as the pulse-by-pulse records and (2) the radar area varies rather slowly with aircraft aspect. These features directed the analysis of the low frequency data which will be discussed under four headings:

1) Similarity of A-scope and pulse-by-pulse records:

The A-scope record was read each second for the highest echo which occurred during the half second the shutter was open. The pulse-by-pulse record will contain more information than this only when there is a significant echo amplitude variation in a period of one second. A typical plot of 115 Mc. A-scope readings along with pulse-by-pulse maximum and minimum values in each second appears in Fig. 3. It is seen that the two records differ appreciably only in the regions of deep echo fading. Later in the

5. Since previous work had indicated that a sampling rate of 60 times per second would be adequate for the fluctuation rates of jet aircraft echoes, the pulse-by-pulse recording rate was 60 pulses per second, although the actual radar repetition rate was 120 cycles per second.

CONFIDENTIAL

CONFIDENTIAL

report, when the variation of radar area with aspect has been discussed, it will be possible to estimate from this figure a target presentation time⁶ during which the echo may be considered constant⁷.

2) Radar area as a function of nominal aspect:

Figs. 4-11 are plots of radar area (as read from the A-scope records) and nominal azimuth aspect (defined in Appendix II) versus time.⁸ In a particular interval the fraction of the total number of points which lie above a given radar area level is the probability that the echo will exceed this level on a single antenna scan, if the presentation time is equal to or less than one second. For longer presentation times, this probability may be obtained in the same way from a running average of the data. Additional observations of a particular probability may be obtained from each repetition of the aspect interval.

3) Radar area as a function of exact aspect:

Figs. 12 and 13 are plots of average radar area versus exact aspect (defined in Appendix II), i.e., they are plots of average radar area versus

6. Target presentation time is defined as the length of time that the antenna is pointed at the target during one revolution of the antenna.

7. This estimate may allow the improvement of target simulators which now include only target variations from scan to scan.

8. All the data for these figures was taken from the 8 - 11 mile range interval where the elevation aspect angle was between 2.30 and 3.20. The flight attitude, aircraft speed (C.A.S. = 193 knots), aerodynamic conditions, and average depression angle of the radar with respect to the airplane axes simulated the tactical situation of an aircraft at attack speed at 40,000 feet altitude flying against a ground based search radar at ranges from 90 to 130 nautical miles.

CONFIDENTIAL

average nominal aspect. The averages were obtained at the points marked by (x) and the connecting lines indicate it is reasonable to assume a smooth variation from point to point. The repetition of a minimum point on successive flights was usually recognizable but a maximum point, always plotted midway between adjacent minimum points, is merely the largest echo which occurred between the minimums. The data are discontinuous near head and tail aspects because a single flight spanned only a few degrees about these aspects and characteristic minimums could not be identified. This difficulty is particularly troublesome at low frequencies where probably only one or two characteristic minimums occur in a 10° or 20° interval around either head or tail aspect. Since there are few minimums, using the largest and smallest observed values as maximums and minimums may not be serious. The curves in Figs. 12 and 13 are dotted in two places to indicate that the actual minimums occurred where the radar area could not be computed accurately in the rapidly changing ground reflection pattern.

4) Aircraft Aspect Fluctuations:

Using the data of Figs. 12 and 13 a list of nominal aspects for each of several minimums was prepared. This list showed a root-mean-square (r.m.s.) deviation from average nominal aspect of 1.5°. This value compares favorably with gyroscope data on aircraft yaw taken by Lewis⁹ which shows an r.m.s. yaw variation of 0.7° to 2.6° for twenty-second samples.

9. Unpublished data by B. L. Lewis, NRL.

CONFIDENTIAL

CONFIDENTIAL

RESULTS

High Frequency (1250 and 2813 Mc.)

The data for these frequencies were taken from the pulse-by-pulse data and were analyzed for probability distributions over certain aspect intervals. This type of analysis allowed comparison of data from several flights even though the echo fluctuations were too rapid to allow the identification of a particular aspect from one run to another.

The sample length was chosen to be twenty seconds which, for a closing speed of 600 mph, spans 3.33 miles of range. This sample time, chosen to be long compared with the natural lateral oscillation period of 2 seconds,¹⁰ spans anywhere from zero to sixteen degrees of azimuth aspect depending upon whether the radar is ahead (behind) or abeam of the aircraft. This aspect interval, often large compared with the 1° or 2° estimates of r.m.s. yaw variations, may be wasteful of information when the aspect is known more accurately than sixteen degrees.

The high frequency data, contained in Tables I and II, indicate the percentage of pulses in a given sample for which the radar area equalled or exceeded a particular level. The gaps in the data at near nose and tail aspects appear for the same reason as in the low frequency data. There are more data on 2813 Mc. than on 1250 Mc. The vertical beamwidth of the 1250 Mc. antenna illuminated the ground at longer ranges and the effects of the resulting fine-structured interference pattern could not be removed, limiting the range interval in which the 1250 Mc. measurements could be taken.

10. Information from Carrier Branch, Flight Test, NATC, Patuxent River, Md.

CONFIDENTIAL

CONFIDENTIAL

The statistical fluctuation of the probability of detection calculated from these data depends on the variance of the data (for a given aspect interval) in a single row of Table I (or II). Because the data in a given row are correlated with those in other rows, no adequate statistical description is undertaken here. A simple first approximation of the statistical fluctuation is described below.

The column headings show that the aspect intervals were repeated from one to six times. The data from the separate flights were intentionally divided into these aspect intervals which gave the maximum number of repetitions. In this regard the data (Table II) for the aspect interval $37.5^\circ - 45^\circ$, which was observed on six different flights, were studied in detail. The first differences of these are shown in Table III, where each difference is the probability that the radar area lay between two consecutive db levels. Also given in Table III are the mean and variance of each row of entries. The observations in several adjacent rows were combined. After subtracting from each entry the mean value for that row and using the entries from several rows as a sample, it was found by the Chi-square test that the data are normally distributed about zero mean with the sample variance. A blind use of this result would produce probabilities greater than one for small values of radar area and negative values of probability for large radar areas. However, it does serve as a first approximation of the row-distribution.

FREQUENCY TREND

The radar area at the lower frequencies is greater than the radar area at the higher frequencies. With large samples of azimuth aspect,

CONFIDENTIAL

CONFIDENTIAL

and with equal weights given to equal aspect intervals, the average radar area at 115 Mc. is about six times greater than the average radar area at 2813 Mc.. This trend is not erased even when the worst possible interpretation of the accuracy estimates of Appendix I is applied. The averaging method which was used¹¹ weights this trend heavily with the large signals occurring at broadside and normal to the leading edge of the wing. At the higher frequencies the narrow broadside echo lobe is sensitive to airplane roll and the very narrow leading edge echo lobe might have been missed. These two factors would tend to lower the higher frequency averages. The importance of these results should therefore be judged on a probability-of-detection basis rather than an average-area basis. No theoretical explanation of this frequency trend is known to the author.

PRESENTATION TIME TREND

A search radar normally accepts all pulses during its presentation time (as modified by (at least) the antenna beam shape), treats them as a unit, and presents to the operator their mean value, for instance. The variation of the radar area during the radar presentation time is thus of importance to the radar designer. Information in this respect is shown in Figs. 14-24 where each figure shows two probability distributions. The solid curves in these figures show the distribution of single pulse amplitudes (i.e., they are plots of data like that found in any column

11. The average of 24 readings (every 5° from 170° to 280°) from Figs. 6 and 7 (115 Mc.) is 53 m². The average of 59 readings (every 2° from 192° to 308°) from the lower half of Fig. 12 (115 Mc.) is 89 m². In Table III (2813 Mc.) the average of ten columns between 172° and 220° and 15 columns between 230° and 310° is 12.5 m². These two ratios were rounded off to six-to-one.

CONFIDENTIAL

CONFIDENTIAL

of Table III), while the dotted curve shows the distribution of median values. The dotted curve was prepared by separating the data from the corresponding solid curve into the indicated time intervals, and plotting the median value in each time interval. The time intervals selected correspond to radar presentation times of 1/12 second (2813 and 1250 Mc), 1/2 second (215 Mc), and 8 seconds (115 Mc).

The change in the probability distribution with presentation time is small, as judged by the similarity of solid and dotted curves. This conclusion should be applied with care because changes of the probability distributions with time are a function of the aircraft's exact-aspect rate. During a straight and level flight, the aspect rate is a function of the aircraft's natural oscillation period (a constant), the aircraft's aspect (aspect rate is greatest at broadside), and the range (aspect rate decreases with increasing range).

CONCLUSIONS

The radar area of the F2H-2 aircraft is greater at the lower frequencies (115 and 215 Mc) than at the higher frequencies (1250 and 2813 Mc). With large samples of azimuth aspect and with equal weights given to equal aspect intervals, the average radar area at 115 Mc is about six times greater than the radar area at 2813 Mc. Repeated observations of a particular aircraft aspect show that the probability that the radar area (corresponding to that aspect) will lie in a 1 db interval is normally distributed. The probability distribution of single pulse amplitudes is essentially equal, over a wide range of aspects, to the

CONFIDENTIAL

CONFIDENTIAL

distribution of median pulse amplitudes, where the medians are obtained from samples corresponding to presentation times (time during which the radar antenna is on target) of 1/12 second (2813 and 1250 Mc.), 1/2 second (215 Mc.) and 8 seconds (115 Mc.).

ACKNOWLEDGEMENTS

The experimental portion of this work was a joint undertaking by the Wave Propagation and Search Radar Branches. The contributions of the Search Radar Branch, Radar Division to this program are gratefully acknowledged.

CONFIDENTIAL

CONFIDENTIAL

APPENDIX I

RADAR CALIBRATIONS

The standard target for the two higher frequencies was a triangular corner reflector (the length from apex to any corner was equal to 2 feet) mounted approximately 25 feet above the water. The standard target for the two lower frequencies was a 10 foot by 10 foot flat screen mounted about 75 feet above the water. Pictures of the targets appear in Figs. 25 and 26.

The radar area of the high frequency standard target, as measured by the radar parameters method during the four operating days, is compared with the theoretical value in Fig. 27. (The height variation is due to tide.) The measured values at 2315 Mc. are scattered approximately ± 3 db about the theoretical value with little relation to target height. The 1250 Mc. measurements are correlated with target height but appear about 2 db low with a scatter of approximately $\pm 1/2$ db.

In an attempt to explain the low measured values for the radar area of the triangular target at 1250 Mc., this target was replaced by an 18 inch by 18 inch flat sheet whose radar area was measured (by the radar parameters method) as the sheet was varied in height. The measured and theoretical values of radar area are plotted against height in Figs. 28 and 29. The support for this target was tilted so that the relative phase of any background echo (from the support) should change with target height. The oscillations in the measured values at 1250 Mc. may be due to an interfering background echo, but since the peaks of the oscillations are below

CONFIDENTIAL

CONFIDENTIAL

the theoretical value, the low values of measured radar area are not explained. Other possible causes for the low measured values are deformation of the target, a reflection coefficient of the sea different from -1, or an erroneous measurement of a radar parameter. Without further information it is concluded that the 1250 Mc. data in this report are low by a factor lying between 0 and 3 db and believed to be nearer to 3 db.

It is reasonable to assume that the background echo (from the target support) is responsible for the differences between the theoretical and measured curves of Fig. 28 (2813 Mc.). Since, in Fig. 29, the background echo at 1250 Mc. changes phase by a full cycle about every 4 feet, the same phase change should occur every 1.8 feet at 2813 Mc.. The "sampling rate" in Fig. 28 was every 1.5 feet (i.e., the flat sheet was moved in height in increments of 1.5 feet), which is sufficiently close to 1.8 feet to explain the slow cycling between measured and theoretical values. Accordingly, it is concluded that the errors in the 2813 Mc. data in this report are small compared with ± 3 db.

The only check on the absolute accuracy of the low-frequency target was a computation (for the 215 Mc. radar) using measured values of transmitted and received powers and a nominal value of antenna gain. According to this computation the 215 Mc. data in this report are 3 db too high. However, this computation is a poor checking procedure (the 3 db difference could be the result of using an incorrect value for nominal antenna gain, a quantity which is squared in the radar area computation) and allows only a negative conclusion: there is no reason to suspect the accuracy

CONFIDENTIAL

CONFIDENTIAL

of the low frequency data in this report.

The measurements have indicated that the ratio of the radar area at 115 Mc. to the radar area at 2813 Mc. is about 6 to 1. After applying the estimates of accuracy, it seems equally likely that this ratio is 3 or 4 to 1.

CONFIDENTIAL

CONFIDENTIAL

APPENDIX II

SUMMARIZING AIRCRAFT ECHO DATA

At any point during a flight an aircraft presents to the radar its "nominal" and its "exact" aspect. Nominal aspect, the usual knowledge, is defined by the bearing and elevation of the radar to the aircraft, and the compass heading, angle of attack, and the roll angle listed in the pilot's orders. Exact aspect is the actual instantaneous aspect of the aircraft and includes the position of the propellers (if any) and any distortion of the airframe or skin.

When only the nominal aspect is known, the data which are necessary for the computation of the probability of detection, could be presented in either of two different forms. In the first, a plot of radar area against exact aspect and the statistics of the deviations from nominal aspect could be given. In the second form, the statistics of the radar area for each nominal aspect interval under consideration could be given.

The first form of the data usually cannot be furnished due to the difficulty of obtaining exact-aspect information. The second form presents difficulties, not in collecting the data, but in that the user is restricted to the time and aspect intervals selected in the data reduction process.

Three, at times contradictory, considerations are in the choosing of sample times and aspect intervals. First, the sample time should not be long compared to the decision time of the tactical problem (for a given tactical problem, answers are required at a rate dependent upon such things

CONFIDENTIAL

CONFIDENTIAL

as target range and speed). Second, the sample time should be long compared to the period of natural oscillation of exact aspect. Third, the aspect interval within a sample should be only reasonably larger than the fluctuations of the exact aspect. To illustrate: The use of a sample that spans 30° of aspect is wasteful of the available information when the aspect is actually known within 30° and produces a coarser-grained plot of the probability of detection.

The compromises which were made in reducing the data for this report were aimed at presenting the most useful and complete data-summaries permitted by the finite number of runs and the finite information known about the exact aspects. The slow fluctuation of the radar area with aspect at 115 and 215 Mc. has permitted an attempt at a one-to-one correlation of radar area with aspect at these frequencies. The more rapid fluctuations and the greater effect of random aspect changes has forced a more statistical description at 1250 and 2813 Mc..

CONFIDENTIAL

CONFIDENTIAL

TABLE I

1250 Mc/m

Cumulative Probability (X100) of $A = 10 \log_{10} \sigma$
(σ in square meters) for Azimuth Intervals I (I in degrees) and
Sample Size Q (Q in number of pulses). Q/60 = Length of Sample in Seconds.

I:	348	351	2.7	15.0	21.8	25.3	28.0	28.0	31.5	31.5
	351	353.5	3.7	16.6	25.0	29.3	31.5	31.5	36.0	38.0
Q:	1200	1200	1200	1200	1200	1200	1080	1200	1080	1200
<u>A</u>										
-17.2										
-16.2	98.9					98.7			98.9	100.0
-15.2	97.4					98.2			98.9	99.8
-14.2	96.4	97.8			95.8	97.4	92.4	99.3	96.7	99.8
-13.2	95.5	96.8		99.3	95.7	96.4	91.0	98.8	96.6	99.5
-12.2	93.9	95.8		97.7	95.5	94.4	89.7	98.1	96.5	99.0
-11.2	92.8	94.9		95.3	95.3	90.6	88.8	97.1	96.3	99.0
-10.2	91.4	93.8		92.9	94.3	84.9	87.4	96.7	95.7	98.9
- 9.2	87.4	92.9		86.5	92.5	79.1	86.1	95.5	95.2	96.8
- 8.2	84.1	92.4		84.4	91.0	74.6	80.7	92.9	93.4	94.3
- 7.2	80.4	91.3		80.5	88.7	72.2	73.2	88.7	90.1	92.1
- 6.2	77.7	89.9		76.7	84.0	66.9	69.1	82.3	84.9	87.5
- 5.2	76.2	87.1		68.7	75.8	63.4	67.1	72.3	78.4	80.1
- 4.2	74.8	84.9		58.2	67.4	61.4	65.7	59.5	71.3	71.9
- 3.2	69.7	83.0		48.7	62.9	57.5	62.7	43.9	65.4	63.8
- 2.2	63.4	78.5		40.9	57.3	52.9	61.3	33.3	59.6	54.2
- 1.2	56.4	66.9		35.3	52.1	47.2	50.6	26.9	52.7	50.5
- 0.2	49.9	59.0		27.8	47.3	40.4	50.3	21.6	45.5	45.8
+ 0.8	45.2	51.7		26.0	43.3	34.4	45.3	11.3	34.4	39.1
1.8	40.8	41.2		23.5	34.0	30.9	37.7	3.7	19.7	32.6
2.8	33.0	32.4		25.1	24.3	27.7	28.1	1.2	14.0	27.0
3.8	19.8	25.8	99.9	18.9	19.0	20.9	18.7	0.4	8.1	25.3
4.8	14.4	14.8	92.8	17.4	12.5	11.4	13.4	0.0	1.8	19.4
5.8	3.3	7.7	88.3	16.2	6.6	3.5	8.6		1.6	10.4
6.8	0.0	1.4	82.0	11.5	0.1	0.0	2.4		1.3	6.9
7.8		0.0	71.2	0.0	0.0		0.1		0.6	4.9
8.8			5.1				0.0		0.0	3.9
9.8			43.9							2.8
10.8			15.6							1.6
11.8			6.0							1.0
12.8			0.2							0.0
13.8			0.0							

CONFIDENTIAL

CONFIDENTIAL

TABLE I
(Continued)

I:	28.0	28.0	33.0	41.0	48.0	48.0	55.0	70.0	73.5	80.0
	36.0	36.0	41.0	48.0	55.0	55.0	62.0	80.0	79.5	86.0
Q:	2160	2400	1800	1140	1200	1440	960	1200	1200	1200
<u>A</u>										
-18.2										
-17.2								99.7		
-16.2					98.9			99.6		
-15.2					98.6			99.5		
-14.2	94.4	99.5	99.8	100.0	98.1			99.2		
-13.2	93.7	99.1	99.5	89.9	97.6	98.9		99.2		
-12.2	93.0	98.5	98.9	89.9	97.3	98.3		99.1		
-11.2	92.5	98.0	97.6	89.6	96.6	96.4		98.5	97.9	
-10.2	91.5	97.8	96.8	89.6	96.1	94.3		98.0	97.6	
- 9.2	90.6	96.1	95.3	89.5	95.6	93.1		97.1	97.1	
- 8.2	87.0	93.6	94.0	89.2	95.0	91.8		96.6	100.0	96.7
- 7.2	81.6	90.4	90.6	89.2	94.0	90.5		95.8	99.9	96.0
- 6.2	77.0	84.9	87.0	89.0	93.0	87.8		95.4	99.7	95.5
- 5.2	72.8	76.2	81.0	87.2	91.5	81.1		94.1	99.6	94.7
- 4.2	68.5	65.7	75.5	85.3	86.3	73.7		93.2	99.3	94.0
- 3.2	64.0	53.8	66.7	84.2	81.0	67.1		91.9	99.1	91.7
- 2.2	60.4	43.8	60.4	83.3	74.2	58.0		90.4	98.8	89.9
- 1.2	54.7	38.8	57.2	79.6	65.6	50.5		83.9	98.7	87.0
- 0.2	48.2	33.7	54.5	68.5	56.7	42.1		75.7	98.1	82.1
+ 0.8	39.8	25.2	45.2	58.6	51.7	34.4		69.9	96.3	78.6
1.8	28.7	18.2	37.7	51.3	47.0	24.0		63.6	93.4	71.8
2.8	21.1	14.1	32.3	46.9	38.0	16.1		54.3	92.0	63.2
3.8	13.4	12.9	27.8	45.4	22.7	12.4		43.6	87.0	49.1
4.8	7.6	9.7	24.9	40.1	15.7	10.4		40.1	81.6	37.3
5.8	5.1	5.2	22.5	34.7	8.2	9.2		25.1	65.1	25.6
6.8	1.9	3.5	18.6	32.2	4.2	7.1		16.7	57.1	17.4
7.8	0.4	2.5	10.8	28.4	3.4	5.5		0.9	49.4	11.6
8.8	0.0	1.9	5.4	21.6	1.9	3.9		0.0	40.4	5.2
9.8		1.4	0.7	17.8	0.2	0.8			33.3	1.3
10.8		0.8	0.0	6.0	0.0	0.0			27.2	0.1
11.8		0.5		0.3					16.0	0.0
12.8		0.0		0.0					7.3	
13.8									3.8	
14.8									0.5	
15.8									0.0	
16.8										16.8
17.8										9.2
18.8										2.1
19.8										1.4
20.8										0.7
										0.0

CONFIDENTIAL

CONFIDENTIAL

TABLE I.
(Continued)

I:	86.5	93.1	171.5	176.3	177.0	182.2	182.8	183.4	196.0
	92.9	99.5	172.4	177.0	177.6	182.4	183.4	184.0	198.0
Q:	1200	1200	1200	1200	1200	1000	900	1680	1140
<u>A</u>									
-18.2							99.1		
-17.2							98.6		
-16.2							98.5		
-15.2							98.2		
-14.2							97.6		98.3
-13.2					98.8		96.7	99.8	97.1
-12.2			100.0		98.5		96.2	99.3	96.8
-11.2			99.9	99.5	96.3		94.7	99.3	96.0
-10.2		100.0	99.9	99.5	95.5		93.3	99.1	95.1
- 9.2		99.8	90.6	99.0	93.9	100.0	91.8	99.0	94.0
- 8.2		99.8	99.5	96.8	92.8	99.5	90.8	98.9	92.9
- 7.2	100.0	99.7	99.4	92.3	92.2	97.1	89.9	98.7	91.9
- 6.2	99.9	99.6	98.0	87.2	90.8	94.6	87.9	98.5	89.8
- 5.2	99.7	99.6	94.6	83.3	89.0	93.4	85.8	98.2	86.4
- 4.2	99.6	99.6	90.6	80.2	87.3	92.6	83.3	97.9	81.5
- 3.2	99.6	99.5	87.0	77.1	85.8	91.6	79.7	97.6	76.2
- 2.2	99.6	99.0	83.8	74.3	84.6	90.0	77.4	97.3	73.6
- 1.2	99.5	98.7	80.7	69.7	82.1	88.0	75.5	97.0	68.4
- 0.2	98.7	98.4	76.6	64.2	80.2	83.7	72.9	95.9	62.3
+ 0.8	97.8	97.9	72.8	57.8	78.3	76.3	68.0	92.6	55.4
1.8	96.6	95.5	66.7	51.7	75.8	63.5	64.4	89.6	47.8
2.8	95.3	92.3	59.4	44.6	72.1	58.6	54.4	88.6	36.6
3.8	93.8	88.4	44.1	35.6	67.3	47.5	42.4	85.2	27.2
4.8	91.3	84.4	26.7	26.8	53.2	26.6	34.1	79.2	14.3
5.8	88.8	79.4	17.5	19.7	50.2	10.4	21.4	67.9	7.2
6.8	86.7	73.7	9.4	15.3	40.8	7.6	10.6	52.2	2.3
7.8	82.8	70.0	2.1	6.7	31.2	1.0	6.2	34.6	0.0
8.8	78.1	62.5	0.0	0.0	25.2	0.0	3.5	13.0	
9.8	73.7	53.4			22.2		0.4	4.6	
10.8	70.4	35.7			20.5		0.0	2.4	
11.8	60.4	23.9			18.9			1.8	
12.8	49.4	19.7			12.2			0.9	
13.8	42.9	13.1			2.2			0.0	
14.8	32.6	6.3			0.2				
15.8	28.3	2.2			0.1				
16.8	23.1	1.2			0.0				
17.8	12.7	0.0							
18.8	4.5								
19.8	1.7								
20.8	0.0								

CONFIDENTIAL

CONFIDENTIAL

TABLE I
(Continued)

I:	198.0	209	213	213	223	223	232	233	233	245
	201.5	213	219	219	233	233	239	245	245	252
Q:	1400	1200	1320	1440	1260	1740	1320	1500	1740	840
<u>A</u>										
-22.2					99.9					
-21.2					99.9					
-20.2					99.8					
-19.2					99.4					
-18.2					98.8					
-17.2					98.4			99.1		
-16.2	92.8		96.1	99.9	98.2			98.8		
-15.2	92.0		94.7	99.1	97.6			98.0		
-14.2	90.9	90.5	93.2	97.9	97.2	98.2	98.2	97.2	94.9	100.0
-13.2	90.8	89.6	90.6	96.3	96.9	97.4	97.9	95.8	92.8	99.9
-12.2	89.1	87.0	87.5	93.9	95.9	97.0	97.8	96.0	90.1	99.2
-11.2	87.6	83.6	84.9	91.6	94.2	95.1	97.7	93.3	87.9	98.6
-10.2	84.3	81.6	82.4	87.7	92.7	92.8	96.9	91.3	84.4	98.3
- 9.2	80.5	79.6	80.1	84.2	91.4	90.6	94.5	86.9	81.9	95.9
- 8.2	78.0	77.3	76.3	80.4	89.3	85.9	90.9	83.7	78.9	93.7
- 7.2	72.9	72.0	72.9	76.2	87.3	80.3	86.8	81.0	77.0	90.7
- 6.2	65.3	64.4	69.3	69.9	84.6	73.5	82.3	78.7	73.3	86.2
- 5.2	59.5	56.9	62.3	58.8	78.8	63.5	80.4	74.6	70.3	81.2
- 4.2	50.5	48.4	52.1	47.2	72.6	56.1	77.2	68.6	64.1	77.6
- 3.2	45.1	37.8	44.4	34.2	64.0	48.6	73.5	62.5	55.9	73.4
- 2.2	45.0	33.2	35.3	23.2	55.9	42.4	69.5	58.8	47.6	65.1
- 1.2	43.6	22.6	25.4	14.3	49.3	37.1	64.7	54.5	37.6	58.2
- 0.2	42.8	15.1	17.7	7.8	41.0	32.4	59.5	49.9	31.2	49.2
+ 0.8	39.8	10.2	11.3	3.0	22.4	24.6	48.3	44.8	21.6	37.5
1.8	36.4	2.7	6.8	0.4	15.0	15.2	41.9	39.6	11.7	26.8
2.8	33.9	0.0	5.5	0.0	8.9	10.5	35.1	27.9	6.7	17.1
3.8	27.9		2.9		6.9	5.9	28.5	17.2	3.7	11.5
4.8	16.1		1.2		4.8	1.3	18.8	12.7	3.0	5.9
5.8	7.4		0.0		0.7	0.2	9.9	7.7	1.7	4.6
6.8	0.0					0.0	0.1	1.5	0.0	1.2
7.8							0.0	0.0		0.0

CONFIDENTIAL

CONFIDENTIAL

TABLE I
(Continued)

I:	245	256	256	256	265	265	265	256	256	256	274
Q:	252	265	265	265	274	274	274	274	274	274	282
A	960	1080	1080	1500	1020	1080	1440	2100	2160	2940	840
-15.2		100.0					100.0				
-14.2	100.0	99.9					93.7				
-13.2	99.8	99.9					99.4		100.0		99.9
-12.2	99.6	99.4					99.1	100.0	99.7		99.9
-11.2	99.4	99.2					98.9	99.9	99.6		99.9
-10.2	99.2	99.1					98.5	99.9	99.6		59.9
- 9.2	97.9	98.8					98.3	99.8	99.4	100.0	99.8
- 8.2	95.6	98.0					98.2	99.6	99.0	99.7	99.8
- 7.2	93.2	97.9					97.6	99.5	98.9	99.6	99.7
- 6.2	81.6	97.2			100.0		97.5	99.3	98.6	99.6	99.6
- 5.2	78.0	96.8					99.9	97.1	99.1	98.3	99.4
- 4.2	71.8	96.6	100.0				99.6	97.0	98.9	98.1	99.0
- 3.2	68.6	95.3	99.9				99.5	96.7	98.7	97.3	98.9
- 2.2	64.1	93.5	98.9	100.0			99.5	96.4	97.9	96.4	98.6
- 1.2	57.4	88.4	98.5	99.9	99.3	95.9	97.6	93.7	98.3	98.3	98.8
- 0.2	48.4	82.7	98.0	99.9	99.2	95.3	97.3	90.7	98.1	98.1	98.7
+ 0.8	43.9	77.4	96.4	99.5	99.1	94.8	96.9	88.0	97.3	98.2	98.2
1.8	35.2	72.5	93.9	98.8	98.7	94.4	96.7	85.3	96.4	97.8	94.3
2.8	27.3	66.5	90.4	98.7	98.4	93.6	96.4	82.1	93.7	97.6	91.3
3.8	11.8	58.6	89.2	98.4	96.5	92.6	96.0	76.9	90.7	97.2	88.0
4.8	7.1	52.1	87.9	98.3	95.9	91.6	95.7	73.3	88.0	97.0	85.9
5.8	0.4	49.6	87.2	98.1	95.2	90.5	95.1	71.6	85.3	96.6	84.7
6.8	0.0	42.6	87.0	97.1	93.1	88.7	94.4	67.0	82.1	95.8	80.4
7.8		34.0	86.5	95.8	85.8	85.8	93.5	59.0	76.9	94.7	78.1
8.8		30.6	85.7	88.0	82.6	80.8	92.1	55.8	73.3	90.0	73.6
9.8		29.2	82.3	81.2	80.5	77.5	91.4	54.0	71.6	86.2	71.2
10.8		27.6	80.2	76.2	77.8	73.0	90.0	51.9	67.0	82.9	68.2
11.8		26.3	78.7	72.4	73.7	68.9	88.8	49.2	59.0	80.4	62.1
12.8		23.5	76.4	69.3	65.4	61.3	86.3	43.7	55.8	77.6	54.2
13.8		21.0	72.7	66.2	56.8	50.3	82.3	38.3	54.0	74.1	48.8
14.8		17.9	66.0	60.5	48.1	40.6	77.4	32.5	53.3	68.8	40.9
15.8		17.1	53.8	52.2	35.1	35.3	73.2	25.7	44.6	62.5	29.9
16.8		16.7	44.0	42.3	23.2	28.5	69.8	19.7	36.2	55.8	20.4
17.8		15.0	38.1	31.8	12.1	21.8	66.3	13.5	30.0	48.7	10.1
18.8		7.2	24.4	28.1	5.3	11.5	60.1	6.2	17.9	43.8	3.6
19.8		4.0	15.4	23.6	3.6	4.8	50.5	3.8	10.1	36.8	0.1
20.8		0.0	12.7	22.2	2.9	0.2	39.6	1.4	6.4	30.8	0.0
21.8			8.2	19.8	1.5	0.0	29.9	0.7	4.1	24.8	
22.8			3.4	15.5	0.0		15.3	0.0	1.7	15.4	
23.8			0.0	13.2			6.0		0.0	9.7	
24.8				9.9			2.9			6.5	
25.8				7.9			1.8			4.9	
26.8				1.9			0.7			1.4	
27.8				0.1			0.0			0.0	
28.8				0.0							

CONFIDENTIAL

CONFIDENTIAL

TABLE II

2813 Mc/s

Cumulative Probability (X100) of $A = 10 \log_{10} \sigma$
(σ in square meters) for Azimuth Intervals I (I in degrees) and
Sample Size Q (Q in number of pulses). Q/60 = Length of Sample in Seconds.

I:	340.5	345.1	348.7	351.6	353.9	355.9	357.5	2.8	3.9
Q:	345.0	348.6	351.5	353.8	355.8	357.4	359.3	3.8	4.8
Q:	1200	1200	1200	1200	1200	1200	1200	1200	1200
<u>A</u>									
-12.7	99.8			100.0					
-11.6	99.8			99.9					
-10.4	99.6			99.9					99.3
- 9.3	99.6			99.8					99.7
- 8.2	99.6			99.5		100.0		98.9	99.4
- 7.1	99.6		100.0	99.3	100.0	99.9		97.5	98.8
- 5.9	99.4		99.9	96.0	99.9	99.8		96.5	98.1
- 4.8	99.2		99.9	96.8	99.6	99.5		94.0	96.5
- 3.7	98.8		99.8	92.6	99.0	98.7		92.2	95.6
- 2.6	98.1	100.0	99.0	89.6	98.6	97.4		91.0	93.9
- 1.4	96.7	99.9	97.5	88.0	98.0	95.3		89.5	91.0
0.3	95.6	99.8	96.5	86.9	97.2	92.9	99.9	85.8	86.1
0.8	91.7	98.7	94.7	84.5	96.4	89.6	98.7	76.9	79.2
1.9	89.1	96.7	92.3	82.7	95.5	86.8	97.9	70.5	72.9
3.0	87.0	94.1	89.2	77.9	92.1	78.7	97.3	64.0	63.9
4.2	82.4	77.8	83.2	71.8	86.3	63.7	96.6	60.9	54.7
5.3	79.4	55.3	71.1	60.7	79.2	48.4	93.8	57.3	51.2
6.4	76.3	45.7	53.8	46.8	71.4	38.2	89.1	52.1	45.5
7.6	66.4	42.6	28.5	36.1	59.1	25.5	81.3	46.0	39.2
8.7	52.0	40.4	11.7	25.3	43.6	12.5	69.2	43.0	27.1
9.8	37.2	38.2	9.6	12.7	27.9	2.0	52.4	41.2	17.3
10.9	21.9	20.0	9.5	5.5	16.7	0.5	26.8	38.7	4.4
12.0	8.7	10.1	8.7	1.4	8.3	0.0	2.7	34.5	2.0
13.2		4.2	6.8	0.7	1.1		0.0	27.9	0.0
14.3		0.0	2.0	0.2	0.0			17.7	
15.4			0.0	0.0				5.4	
16.5								0.1	
17.7								0.0	

CONFIDENTIAL

CONFIDENTIAL

TABLE II
(Continued)

1:	4.9	11.7	12.5	13.6	15.1	17.0	18.2	20.0	20.0	20.0
	5.5	12.4	13.5	15.0	17.0	18.1	19.9	22.5	22.4	22.5
2:	1200	1200	1200	1200	1200	1200	1200	1200	1680	
<u>A</u>										
-11.6	99.9									
-10.4	99.9							100.0		
- 9.3	99.7		99.1					99.8		
- 8.2	99.7	97.2	98.3	100.0		99.2		99.4	98.5	98.9
- 7.1	99.3	95.6	96.7	99.2		98.3		99.2	97.9	98.6
- 5.9	98.4	93.9	94.9	97.9		95.6		98.7	97.6	98.2
- 4.8	96.9	91.3	91.4	96.2		93.0		98.2	97.5	97.8
- 3.7	91.6	87.6	89.4	91.8		89.5	100.0	97.3	96.6	97.0
- 2.6	87.1	81.4	86.9	87.9		86.9	99.9	96.2	96.4	96.3
- 1.4	84.4	73.4	65.7	82.1		83.6	99.3	94.2	95.1	94.7
- 0.3	79.5	64.8	83.2	75.7	100.0	82.4	98.6	91.6	93.3	92.4
+ 0.8	72.6	56.7	80.7	70.2	99.7	79.9	97.0	89.7	92.7	91.1
1.9	65.4	47.3	76.2	65.7	98.2	78.6	96.1	87.7	83.3	85.5
3.0	55.7	39.3	72.8	61.5	95.0	78.0	93.2	86.2	78.9	82.5
4.2	45.9	29.1	69.9	56.6	93.1	75.5	90.2	81.3	75.1	78.2
5.3	37.6	20.6	69.0	51.1	86.5	67.5	84.3	70.7	67.6	69.1
6.4	26.5	16.3	67.6	42.6	78.2	57.4	74.2	59.0	59.6	59.3
7.6	19.2	13.2	63.4	33.8	69.7	48.0	65.4	54.7	49.2	51.9
8.7	15.2	9.8	60.4	27.3	58.9	36.9	51.8	49.2	33.8	41.5
9.8	10.4	5.5	52.6	20.5	48.6	24.2	40.1	41.9	19.9	30.9
10.9	5.6	4.0	42.1	9.7	35.2	11.9	24.2	23.1	8.9	15.0
12.0	3.7	3.1	32.7	3.2	15.2	5.3	12.2	13.4	2.0	7.7
13.2	2.3	1.7	24.3	0.0	6.9	1.0	2.7	4.1	0.4	2.2
14.3	0.0	0.0	12.2		1.4	0.0	0.0	1.4	0.0	0.7
15.4			2.2		0.0					0.0
16.5			1.2							
17.7			0.0							

* Denotes average of all data for indicated azimuth interval.

CONFIDENTIAL

CONFIDENTIAL

TABLE I.

(Continued)

I:	22.5	22.5	22.5	25.5	25.5	25.5	25.5	30.0	30.0	30.0
	25.3	25.4	25.3	29.9	29.7	29.8	29.9	37.2	37.4	37.3
Q:	1320	1860		1440	1800	1980		1440	1800	1920
<u>A</u>										
-19.4								99.9		
-18.3								99.9		
-17.2								99.8		
-16.1								99.8		
-14.9								99.8	96.8	99.7
-13.8								99.8	98.5	99.6
-12.7				99.1				99.8	97.7	99.3
-11.6				99.0			85.8	99.4	97.4	96.9
-10.4	98.9	99.9	99.4	98.5			85.8	99.4	97.4	96.3
- 9.3	98.6	99.9	99.1	97.4		100.0	85.8	98.7	96.8	96.3
- 8.2	98.5	99.9	98.1	96.8		99.9	85.8	97.4	95.9	97.4
- 7.1	98.5	99.8	99.1	95.3	100.0	99.7	85.8	96.4	94.5	96.3
- 5.9	98.2	99.3	99.0	94.3	99.9	99.5	85.8	95.6	91.7	94.7
- 4.9	98.2	98.3	98.3	92.7	99.6	99.4	85.8	92.9	88.6	91.7
- 3.7	97.7	96.9	97.3	91.3	99.8	99.1	85.8	90.4	85.3	88.4
- 2.6	96.9	96.0	96.5	87.9	99.3	98.8	85.8	85.8	81.7	84.3
- 1.4	93.4	95.5	93.4	84.8	98.7	98.8	85.8	80.5	77.0	78.9
- 0.3	91.1	87.2	89.1	79.7	97.2	97.9	85.8	74.7	72.6	71.1
+ 0.8	86.4	78.4	82.4	72.2	96.6	96.8	85.8	66.6	66.5	63.3
1.9	83.4	72.6	78.0	67.4	94.5	95.6	85.8	66.6	66.5	63.3
3.0	71.7	64.3	68.0	57.9	85.5	91.6	85.8	58.8	50.8	54.4
4.2	59.1	56.1	57.6	47.4	72.6	75.5	85.8	58.8	50.8	54.4
5.3	45.9	45.6	45.7	32.8	62.4	64.7	85.8	48.2	52.0	46.2
6.4	38.8	35.1	36.9	22.5	55.9	51.2	85.8	39.3	45.1	38.9
7.6	28.9	24.7	26.8	14.4	43.4	38.9	85.8	32.5	34.4	32.7
8.7	18.3	12.9	15.6	10.0	37.4	15.1	85.8	25.6	28.1	28.8
9.8	12.4	2.5	7.4	8.4	24.3	7.5	85.8	20.9	17.8	17.1
10.9	6.3	0.0	3.1	5.8	14.1	1.6	85.8	14.7	7.3	10.0
12.0	0.1		0.0	2.4	5.0	0.0	85.8	8.0	1.6	5.6
13.2	0.0			0.0	0.9		85.8	5.5	0.8	5.2
14.3					0.0		85.8	3.7	0.0	3.9
							85.8	1.9		2.3
							85.8	0.0		0.0

* Denotes average of all data for indicated azimuth interval.

CONFIDENTIAL

CONFIDENTIAL

TABLE I)
(Continued)

I:	30.0	30.0	30.0	37.5	37.5	37.5	37.5	37.5	37.5	37.5	37.5
	37.3	37.2	37.3	45.0	45.0	45.0	45.0	45.0	45.0	45.0	45.0
Q:	2160	2640		1080	1200	1200	1320	1800	1960		
<u>A</u>											
-21.7				99.8							
-20.6				99.7							
-19.4				99.6							
-18.3				99.5		99.7					
-17.2				99.4		99.6					
-16.1				98.8	99.9	99.2					
-14.9				98.2	99.9	98.9	99.3				
-13.8				98.0	99.3	98.2	99.3				
-12.7				97.2	99.4	98.4	98.9	97.7			
-11.6	96.5			97.2	98.7	97.9	98.4	97.0			
-10.4	94.6			96.8	97.5	97.5	98.2	95.9			
- 9.3	93.5	95.9	95.6	95.6	96.5	96.8	96.2	94.9	95.4	96.1	
- 8.2	90.9	94.2	94.1	96.1	94.2	95.9	94.7	93.4	93.5	94.5	
- 7.1	87.2	91.5	91.7	95.2	92.3	95.0	93.7	93.8	91.7	92.8	
- 5.9	83.2	89.2	88.7	94.6	90.0	93.7	90.6	87.7	89.6	90.7	
- 4.8	79.6	86.4	85.6	93.9	87.4	92.4	87.9	86.9	86.8	88.2	
- 3.7	75.3	83.0	81.6	92.5	83.7	90.1	84.5	76.9	83.9	85.2	
- 2.6	71.8	79.1	77.1	90.5	79.8	86.1	82.7	72.1	80.6	82.0	
- 1.4	66.6	74.4	71.5	87.2	74.3	82.2	81.7	66.6	77.1	78.2	
- 0.3	61.1	68.9	64.9	78.9	69.0	74.7	80.1	61.2	68.6	72.0	
* 0.8	57.2	63.7	58.6	71.1	64.9	63.5	78.1	56.1	59.5	65.5	
1.9	52.8	55.0	50.5	61.8	62.0	49.6	73.4	51.0	52.0	58.3	
3.0	39.0	43.2	40.7	56.4	58.5	38.1	68.1	47.3	43.7	52.0	
4.2	30.8	28.8	31.5	45.3	53.9	29.3	59.6	42.1	35.2	44.2	
5.3	19.6	18.9	23.4	35.4	49.0	21.1	46.5	33.0	27.7	35.4	
6.4	9.0	9.3	14.4	27.5	37.2	12.9	32.2	19.9	18.4	24.7	
7.6	3.8	5.1	7.8	24.8	20.7	4.3	14.8	14.2	13.2	15.4	
8.7	0.2	1.1	2.9	21.4	3.7	0.4	6.3	10.3	4.1	7.7	
9.8	0.0	0.0	1.9	14.3	1.4	0.0	4.7	3.6	1.0	4.2	
10.9			1.5	4.6	0.0		0.7	2.5		1.3	
12.0			0.6	0.0			0.0	1.5		0.2	
13.2			0.0					0.4		0.1	
14.3								0.0		0.0	

* Denotes average of all data for indicated azimuth interval.

CONFIDENTIAL

CONFIDENTIAL

TABLE II
(Continued)

<u>L</u>				
	45.0	45.0	45.0	45.0
	58.0	58.0	57.7	57.7
				*
<u>Q:</u>	1560	1620	3070	
<u>A</u>				
-19.4	99.8	99.4		
-18.3	99.8	99.2		
-17.2	99.7	99.1		
-16.1	99.5	99.1		
-14.9	99.1	99.1		
-13.8	98.8	99.0		
-12.7	98.5	98.7		
-11.6	97.9	98.6		
-10.4	97.5	98.3		
- 9.3	97.2	98.0	96.2	97.2
- 8.2	96.8	97.6	94.9	96.5
- 7.1	95.4	97.4	93.1	95.3
- 5.9	94.8	96.3	90.7	93.9
- 4.8	92.7	94.5	87.3	91.5
- 3.7	91.3	93.4	85.6	90.1
- 2.6	89.1	90.3	82.9	87.5
- 1.4	87.0	86.6	79.8	84.5
- 0.3	81.5	79.0	76.9	79.1
+ 0.8	73.8	71.4	73.5	72.9
1.9	64.7	59.9	68.6	64.5
3.0	52.6	49.5	63.2	55.1
4.2	43.9	37.0	57.0	45.9
5.3	35.9	25.4	50.9	37.4
6.4	29.2	15.2	43.8	29.4
7.6	20.4	10.4	34.0	21.6
8.7	9.6	5.4	23.6	13.2
9.8	4.9	2.3	18.0	8.4
10.9	2.2	1.1	15.3	6.2
12.0	0.4	0.9	7.3	2.9
13.2	0.0	0.1	2.2	0.7
14.3		0.0	0.0	0.0

* Denotes average of all data for indicated azimuth interval.

CONFIDENTIAL

CONFIDENTIAL

TABLE II

(Continued)

I:	45.0	45.0	45.0	52.0	52.0	52.0	58.0	58.0	58.0	70.0
	51.8	51.8	51.8	57.7	57.7	57.7	70.0	69.8	70.0	77.7
Q:	1500	1800		1200	1500		1560	2400		1500
<u>A</u>										
-18.3							99.5			
-17.2							99.3			
-16.1							98.9			
-14.9							98.5			
-13.8							97.9			
-12.7							97.3			
-11.6	98.4			96.4			95.6			
-10.4	98.0			94.8			96.1			99.6
- 9.3	97.4	98.2	97.8	93.3			95.2	98.4	97.1	98.9
- 8.2	95.5	97.7	96.6	90.8	90.8	90.8	94.8	97.6	96.2	97.8
- 7.1	94.6	96.6	95.6	87.8	86.6	87.2	93.4	96.4	94.9	97.1
- 5.9	93.3	95.5	94.4	83.4	81.9	82.7	88.0	95.0	91.6	95.6
- 4.8	91.4	94.8	93.1	76.1	78.3	77.2	84.8	92.4	88.6	83.5
- 3.7	86.5	93.6	90.1	73.6	74.0	73.8	82.2	89.0	85.9	92.0
- 2.6	83.7	92.6	88.2	68.5	67.8	68.1	80.4	86.1	83.2	89.6
- 1.4	78.8	90.9	84.9	63.2	61.6	62.4	75.3	81.2	78.6	85.3
- 0.3	73.6	90.1	81.8	57.1	53.7	55.4	69.1	76.2	72.9	78.8
+ 0.8	67.6	88.7	78.1	50.8	48.1	49.4	62.6	69.3	66.3	71.6
1.9	63.6	85.6	74.6	43.2	42.8	43.0	55.9	64.1	60.0	65.1
3.0	58.3	80.3	69.3	37.5	36.1	36.8	44.2	56.3	50.6	60.2
4.2	50.6	73.1	61.8	32.7	29.7	31.2	27.0	46.9	37.0	52.3
5.3	40.5	66.6	53.6	27.3	27.1	27.2	11.3	35.5	23.4	45.6
6.4	27.3	58.5	42.9	21.7	24.3	23.0	5.6	24.0	14.6	31.4
7.6	16.9	45.5	31.2	16.7	19.4	18.0	1.9	17.8	9.8	20.2
8.7	12.1	34.5	23.3	7.3	9.8	8.6	1.3	11.9	6.6	11.3
9.8	9.4	29.2	19.3	1.4	4.7	3.1	0.3	5.2	2.7	5.8
10.9	5.2	25.2	15.2	0.4	1.7	1.0	0.0	2.1	1.1	1.4
12.0	2.3	12.2	7.2	0.0	0.1	0.0		0.5	0.3	0.0
13.2	0.0	3.6	1.8					0.0	0.0	
14.3		0.0								

* Denotes average of all data for indicated azimuth interval.

CONFIDENTIAL

CONFIDENTIAL

TABLE II
(Continued)

I:	78.0	78.0	78.0	78.0	85.0	35.0	85.0	85.0	92.0	92.0
	84.6	84.7	84.8	84.8	91.7	91.7	91.3	91.7	99.7	99.8
Q:	1200	1260	1380		1380	1260	1320		1620	1440
<u>A</u>										
-11.6	99.6									
-10.4	99.6		99.7				100.0			
- 9.3	99.5	98.4	99.1	99.0	99.9	99.9	99.9	99.9		99.8
- 8.2	99.1	98.4	98.8	98.8	99.8	99.8	99.9	99.8		99.8
- 7.1	98.7	98.2	98.3	98.4	99.8	99.8	99.6	99.7		99.8
- 5.9	97.9	97.9	97.9	97.9	99.8	99.7	99.5	99.6		99.6
- 4.8	97.1	97.6	97.2	97.3	99.8	99.7	99.0	99.5		99.5
- 3.7	96.1	97.3	96.7	96.7	99.8	99.6	98.9	99.4		99.5
- 2.6	94.9	96.5	95.7	95.7	99.6	99.6	98.6	99.2		99.1
- 1.4	93.3	95.6	94.4	94.4	99.3	99.3	98.5	99.0	100.0	98.9
- 0.3	91.6	94.8	92.5	92.9	99.0	99.3	98.3	98.8	99.9	98.3
+ 0.8	90.8	93.5	90.7	91.7	98.7	99.0	97.7	98.4	99.6	97.7
1.9	89.4	92.1	88.7	90.1	98.5	98.9	97.4	98.3	99.3	96.1
3.0	88.2	90.6	86.4	88.4	97.9	98.8	96.9	97.8	98.9	94.4
4.2	85.9	88.8	83.0	85.9	97.6	98.6	96.7	97.6	98.7	93.3
5.3	82.1	86.1	79.6	82.6	96.9	98.2	95.9	97.0	98.5	91.6
6.4	76.3	79.6	74.2	76.7	95.9	98.0	94.4	96.1	97.9	89.6
7.6	71.0	73.8	68.2	71.0	94.1	97.6	93.0	94.9	97.5	86.6
8.7	62.1	67.6	61.0	63.5	92.1	96.7	91.8	93.5	97.0	81.4
9.8	54.9	58.7	53.6	55.7	89.6	95.8	90.9	92.1	96.1	78.5
10.9	49.3	52.8	46.7	49.6	87.1	94.6	86.7	89.5	94.5	73.8
12.0	40.9	43.2	36.3	40.1	84.8	93.1	83.8	87.3	92.5	68.9
13.2	32.6	33.8	26.0	30.8	82.8	90.1	79.4	84.1	89.6	63.7
14.3	26.2	22.6	17.1	21.9	79.8	83.1	75.6	79.5	83.3	57.8
15.4	19.9	3.6	8.1	10.5	76.8	72.5	71.9	73.7	76.9	50.1
16.5	14.8	2.5	4.0	7.1	65.8	61.8	65.6	64.4	70.5	44.4
17.7	8.1	1.5	1.9	3.8	56.8	49.4	51.9	52.4	61.9	38.7
18.8	3.8	1.2	0.0	1.7	43.2	39.0	40.9	41.0	53.4	33.6
19.9	2.6	0.1		0.9	33.9	30.9	33.3	32.7	47.4	28.0
21.0	0.7	0.0		0.2	27.7	23.3	22.6	24.5	44.5	24.9
22.1	0.0				17.6	18.7	11.3	15.9	40.1	22.4
23.3					11.4	12.7	7.9	10.7	34.3	20.4
24.4					7.5	6.8	2.3	5.6	28.1	18.6
25.5					4.2	2.0	1.5	2.6	25.5	13.8
26.7					2.2	0.0	0.9	1.0	22.1	
27.8					0.9		0.0	0.3	11.0	
28.9									6.2	

* Denotes average of all data for indicated azimuth interval.

CONFIDENTIAL

CONFIDENTIAL

TABLE II
(Continued)

I:	92.0	92.0	100.0	100.0	100.0	100.0	107.0	107.0	107.0
	99.5	99.7	106.8	106.8	106.8	106.8	112.8	112.7	112.8
Q:	1500		1560	1260	1320		1380	1260	
<u>A</u>									
-10.4					99.9				
- 9.3				99.8	99.6			99.0	
- 8.2			98.7	99.6	99.3	98.8	99.0	98.5	99.0
- 7.1	99.9		97.5	99.3	98.6	98.0	97.7	98.2	98.2
- 5.9	99.9		96.6	99.0	98.3	97.5	95.6	97.1	96.6
- 4.8	99.9	100.0	95.7	97.7	97.8	96.6	94.6	95.5	95.3
- 3.7	99.9	100.0	94.2	96.6	97.6	95.7	91.1	92.2	91.8
- 2.6	99.9	99.8	92.5	94.8	97.0	94.3	87.2	90.5	89.1
- 1.4	99.8	99.6	90.7	92.9	96.4	92.9	81.6	86.7	84.3
- 0.3	99.8	99.3	87.8	90.9	96.0	91.6	76.9	83.3	80.6
+ 0.8	99.7	99.0	84.8	89.2	94.8	89.6	68.3	77.0	72.9
1.9	99.6	98.3	82.0	86.6	92.7	89.1	54.8	69.3	62.2
3.0	99.4	97.6	78.4	82.1	88.9	83.1	43.3	62.1	52.9
4.2	99.3	97.1	75.2	77.6	85.2	79.3	34.6	55.6	45.3
5.3	99.1	96.4	71.0	74.7	83.3	76.3	28.3	48.8	38.7
6.4	98.8	95.4	63.9	68.7	79.4	70.7	18.9	43.1	31.2
7.6	97.3	93.8	56.6	61.4	76.7	64.9	13.6	34.5	24.2
8.7	95.4	91.2	49.6	52.5	64.8	55.6	8.1	26.6	17.5
9.8	92.8	89.1	44.7	42.7	57.0	48.1	2.4	15.6	9.2
10.9	90.6	86.3	35.1	35.8	44.4	38.4	0.1	7.3	3.9
12.0	86.3	82.6	24.3	23.6	32.6	26.8	0.0	0.5	0.4
13.2	82.4	78.6	16.6	11.7	25.4	17.9		0.1	0.2
14.3	79.1	73.4	12.6	5.8	18.2	12.2		0.0	0.1
15.4	75.7	67.6	8.7	0.1	10.9	6.6			
16.5	72.4	62.4	5.9	0.0	7.9	4.6			
17.7	67.2	55.9	2.4		4.6	2.3			
18.8	61.2	49.4	1.8		1.1	0.9			
19.9	58.1	44.5	1.0		0.0	0.3			
21.0	53.5	40.9	0.5			0.2			
22.1	44.3	35.6	0.0						
23.3	35.9	30.2							
24.4	24.5	23.7							
25.5	14.4	17.9							
26.7	9.5								
27.8	5.3								

* Denotes average of all data for indicated azimuth interval.

CONFIDENTIAL

CONFIDENTIAL

TABLE II
(Continued)

I:	113.0	113.0	113.0	118.5	172.4	173.0	173.3	175.0	178.0
	118.2	118.2	118.2	124.7	173.0	173.3	173.5	176.0	176.7
Q:	1260	1200	*	1680	1200	1200	1200	1200	1200
<u>A</u>									
-17.2									98.3
-16.1									98.1
-14.9									97.8
-13.8									97.2
-12.7								100.0	97.2
-11.6								99.9	96.6
-10.4						100.0		99.9	95.7
- 9.3						99.5		99.8	93.4
- 8.2						98.8		99.2	91.8
- 7.1	97.2	93.7				95.7		98.5	90.2
- 5.9	94.9	90.8	94.0	88.1	93.2	99.1		96.5	88.7
- 4.8	91.6	88.9	92.0	84.6	86.2	98.4		95.4	87.7
- 3.7	89.8	84.5	88.1	79.2	76.2	96.3		93.2	85.9
- 2.6	84.7	80.6	85.2	71.8	62.6	92.8		90.0	83.3
- 1.4	78.2	75.7	80.2	64.7	48.1	89.1	100.0	86.1	80.7
- 0.3	67.8	69.9	74.1	57.4	33.1	83.6	99.9	80.3	77.9
+ 0.8	55.4	64.2	66.0	49.2	16.7	76.6	99.9	75.4	70.7
1.9	41.8	55.7	55.6	39.2	7.4	62.6	90.3	67.3	62.9
3.0	28.8	39.8	40.8	29.6	3.8	54.6	80.9	54.7	45.2
4.2	18.9	30.1	29.5	19.9	1.8	45.2	76.7	37.5	28.2
5.3	14.0	21.0	20.0	11.8	1.1	40.4	72.6	23.8	18.2
6.4	6.9	12.5	13.3	8.1	0.0	36.9	70.3	15.5	12.3
7.6	3.2	9.5	8.2	5.8		31.2	58.2	7.8	3.6
8.7	2.7	4.8	4.0	3.4		20.7	33.4	3.8	2.8
9.8	1.2	3.1	2.9	2.0		13.7	7.2	0.2	1.8
10.9	0.3	0.3	0.7	0.2		5.9	0.0	0.0	0.0
12.0	0.0	0.0	0.2	0.0		0.2			
						0.0			

* Denotes average of all data for indicated azimuth interval.

CONFIDENTIAL

CONFIDENTIAL

TABLE II.

(Continued)

I:	176.7	177.4	178.0	178.3	182.2	182.2	182.2	182.6	193.2
	177.4	178.0	178.3	178.5	182.2	182.2	182.6	183.5	193.3
Q:	1200	1200	1200	1200	1200	1200	1200	1200	1440
<u>A</u>									
-14.9								99.9	
-13.8	100.0							99.9	
-12.7	99.8	98.6						99.8	
-11.6	98.9	98.1						99.6	
-10.4	98.0	97.7	99.7					99.4	
- 9.3	97.3	97.5	99.1			99.9	99.6	99.0	
- 8.2	96.2	96.6	98.0	98.6	99.4	99.9	99.3	98.0	
- 7.1	95.5	95.4	95.2	97.6	97.9	99.5	98.7	96.3	99.9
- 5.9	94.7	92.7	94.7	96.4	97.1	97.0	96.6	93.7	99.1
- 4.8	93.4	89.9	93.2	94.8	93.1	92.9	92.7	89.1	97.0
- 3.7	91.7	86.7	91.4	92.3	91.5	89.8	84.7	86.1	92.6
- 2.6	89.4	83.2	88.2	88.1	89.2	84.8	76.6	82.0	89.6
- 1.4	85.2	76.9	85.7	82.2	85.9	80.9	67.2	77.1	86.4
- 0.3	77.4	67.7	82.1	75.4	81.1	71.3	62.3	73.2	83.8
+ 0.8	72.0	51.8	73.2	69.0	76.5	61.5	59.1	70.3	79.4
1.9	65.6	36.0		62.3	67.5	54.4	53.3	67.2	69.6
3.0	59.0	25.6	58.7	54.3	56.7	47.3	49.5	60.0	55.8
4.2	44.5	15.1	43.2	41.8	30.8	42.0	43.4	50.1	38.4
5.3	29.4	8.7	24.0	27.6	20.3	36.2	36.3	36.3	28.0
6.4	19.8	3.4	9.8	12.3	11.3	28.6	28.9	17.2	14.9
7.6	14.0	2.1	4.7	6.5	4.6	21.1	17.7	6.4	4.6
8.7	7.2	0.0	2.6	1.9	1.9	9.6	4.0	0.1	1.5
9.8	3.7		0.1	0.7	0.0	2.3	0.0	0.0	0.0
10.9	0.7		0.0	0.0		0.0			
12.0	0.0								

CONFIDENTIAL

CONFIDENTIAL

TABLE II
(Continued)

I:	193.3	193.5	192.6	194.1	195.9	197.2	198.4	202	202
	193.5	193.8	194.0	195.8	198.2	198.2	202.0	210	210
Q:	1440	1440	1320	1320	1320	1260	1320	1800	3420
<u>A</u>									
-19.4								98.5	
-18.3								94.8	
-17.2								93.2	
-16.1								91.8	
-14.9							98.9	91.8	
-13.8		99.6					99.8	89.8	
-12.7		99.5					97.8	87.4	
-11.6		99.3			98.7		97.5	84.3	
-10.4	99.0	99.0			97.8	99.6	96.4	81.1	
- 9.3	98.7	98.6		99.8	96.9	98.7	95.2	78.2	
- 8.2	98.3	98.1		99.6	95.3	98.1	93.1	74.3	
- 7.1	98.0	96.9		99.1	94.6	97.3	90.4	69.6	81.6
- 5.9	97.8	95.5		97.9	92.9	95.8	83.9	60.0	76.9
- 4.8	96.8	93.7		95.1	89.4	92.7	81.7	50.8	71.9
- 3.7	96.0	90.9		91.8	85.0	88.3	76.9	44.5	64.8
- 2.6	95.2	84.8	100.0	86.6	81.3	81.6	74.1	39.2	57.5
- 1.4	92.5	79.6	97.7	78.8	75.6	73.5	70.1	33.0	47.7
- 0.3	89.7	74.2	93.7	71.7	71.3	61.1	61.7	25.5	38.1
+ 0.8	86.2	70.3	88.9	59.7	67.1	52.6	52.3	16.4	26.2
1.9	75.4	66.3	75.3	51.6	63.1	42.8	34.4	7.7	17.5
3.0	62.2	61.5	55.9	44.4	58.3	31.5	21.4	2.4	12.9
4.2	52.4	54.0	27.4	34.8	51.0	28.8	7.4	1.2	6.3
5.3	44.6	41.5	14.8	27.4	39.0	24.9	2.9	0.4	2.4
6.4	39.8	28.5	9.8	17.4	23.8	23.2	1.4	0.0	0.0
7.6	27.0	19.4	4.2	6.3	16.2	16.2	0.1		
8.7	20.3	8.8	0.0	1.9	8.2	9.9	0.0		
9.8	11.2	4.8		0.8	5.1	7.0			
10.9	5.5	1.9		0.0	1.7	4.9			
12.0	1.8	1.1			0.5	2.8			
13.2	0.0	0.3			0.0	0.0			
14.3		0.0							

CONFIDENTIAL

CONFIDENTIAL

TABLE II.

(Continued)

I:	202.1	202	202	202.1	202	206.1	206.1	206.1	210.2
	210.0	210*	206	206.0	206*	210.0	210.0	210.0*	214.0
Q:	3600		1920	2040		1500	1560		1080
<u>A</u>									
-13.8									85.8
-12.7									81.3
-11.6						87.9			78.6
-10.4						81.9	91.7	86.8	75.3
- 9.3						76.5	88.8	82.6	69.6
- 8.2	90.7	80.6	89.3	95.6	92.4	71.6	84.5	78.0	63.8
- 7.1	88.6	74.2	86.1	93.6	89.8	65.2	75.4	70.3	58.7
- 5.9	79.8	67.5	83.9	90.2	87.0	56.6	66.5	61.5	50.6
- 4.8	71.9	60.4	78.6	84.5	81.5	47.2	55.6	51.4	45.8
- 3.7	60.6	52.4	72.2	74.1	73.1	38.6	43.1	40.9	39.1
- 2.6	48.5	43.0	62.9	61.0	61.9	28.1	32.0	30.1	34.2
- 1.4	39.5	34.4	50.9	52.0	51.4	21.6	23.0	22.3	28.7
- 0.3	31.0	24.6	36.8	42.7	39.8	12.6	15.8	14.2	20.3
+ 0.8	22.7	15.9	25.5	32.1	28.8	7.1	10.4	8.7	13.2
1.9	13.6	9.6	19.1	20.7	19.9	5.1	4.2	4.6	9.1
3.0	6.3	4.6	9.4	11.0	10.2	2.3	0.1	1.2	5.2
4.2	1.8	1.5	2.9	3.2	3.0	1.7	0.0	0.9	1.7
5.3	0.4	0.2	0.0	0.8	0.4	0.0		0.0	0.0
6.4	0.0	0.0		0.0	0.0				

* Denotes average of all data for indicated azimuth interval.

CONFIDENTIAL

CONFIDENTIAL

TABLE II
(Continued)

I:	210.2	210.2	210.2	214.1	214.3	214.1	214.1	214.2	214.1
	214.0	214.0	214.0*	220.0	220.0	220.0	220.0	220.0	220.0*
Q:	1260	1320		1200	1260	1680	1920	1740	
<u>A</u>									
-16.1	99.9			98.3	99.8				
-14.9				98.1	99.7				
-13.8	95.9			97.5	99.5				
-12.7	95.2			96.5	99.5				
-11.6	94.5			96.1	99.4				
-10.4	93.3			94.9	99.2				
- 9.3	91.7			93.6	98.4	98.9			
- 8.2	90.2			91.8	96.8	97.7	84.9		
- 7.1	86.8	92.9	78.5	88.4	95.2	96.4	91.6	95.6	91.4
- 5.9	84.1	87.5	74.1	84.1	91.2	94.3	77.9	93.7	88.2
- 4.8	78.6	79.2	67.9	78.9	88.3	91.7	73.2	91.4	84.7
- 3.7	72.3	73.8	61.8	70.7	86.1	87.7	67.0	88.7	80.0
- 2.6	63.7	68.8	55.6	64.2	80.7	80.6	59.3	82.6	73.5
- 1.4	53.6	62.7	48.3	54.2	74.4	75.6	49.5	76.0	65.9
- 0.3	40.1	52.7	37.7	42.7	64.6	67.2	39.2	60.0	54.7
+ 0.8	28.4	36.0	25.9	31.0	53.8	53.1	32.5	40.9	42.2
1.9	15.9	23.3	16.1	20.7	40.9	44.5	25.8	28.0	32.0
3.0	8.2	14.1	9.2	11.1	29.3	34.7	19.9	18.7	22.7
4.2	3.8	5.7	3.7	5.6	20.3	25.2	10.1	13.6	14.9
5.3	0.3	2.1	0.8	1.2	13.2	20.0	5.1	6.5	9.2
6.4	0.0	0.1	0.0	0.2	8.2	13.6	2.5	1.4	5.2
7.6		0.0		0.0	0.1	6.1	1.9	0.4	1.7
8.7					0.0	1.1	1.0	0.0	0.4
9.8						0.0	0.1		0.0
10.9							0.0		

* Denotes average of all data for indicated azimuth interval.

CONFIDENTIAL

CONFIDENTIAL

TABLE II

(Continued)

I:	220.2 230.0	220.4 230.0	220.2 230.0	220.2 230.0	220.2 230.0	220.2 230.0	230.4 242.0	230.5 242.0	230.4 242.0
Q:	1440	1320	1920	2340	2460		1200	1200	1680
<u>A</u>									
-21.7							98.6		
-20.6							96.6	99.1	
-19.4	98.1						98.1	98.7	
-18.3	97.1	97.4					97.2	98.3	
-17.2	96.3	96.7					96.7	98.0	
-16.1	95.2	95.2					95.7	97.4	95.0
-14.9	94.0	94.1					94.7	96.2	95.0
-13.8	91.8	92.0					94.1	94.5	93.9
-12.7	90.1	89.9	90.4				92.8	92.6	92.6
-11.6	85.5	88.1	86.9				89.7	90.6	90.6
-10.4	81.8	85.0	82.5	92.1			87.2	89.5	88.0
- 9.3	76.1	81.8	77.4	88.8	78.7	80.6	83.3	86.9	85.4
- 8.2	70.6	78.6	70.3	84.2	73.8	75.5	79.5	84.0	82.7
- 7.1	64.0	74.1	60.6	79.3	66.8	68.9	75.7	79.3	79.1
- 5.9	56.6	68.7	52.9	74.1	58.6	62.2	70.7	73.1	75.1
- 4.8	50.8	61.2	45.9	67.6	47.2	54.5	63.7	69.9	70.2
- 3.7	45.7	52.3	38.2	60.0	34.3	46.1	57.4	61.1	65.3
- 2.6	36.0	39.7	27.9	50.5	23.7	35.5	53.0	50.7	58.9
- 1.4	27.6	28.2	20.4	39.0	15.5	26.1	47.3	41.6	52.1
- 0.3	18.4	20.1	14.8	26.7	9.7	17.9	39.3	33.1	44.0
+ 0.8	10.5	12.7	10.2	14.4	4.6	10.5	29.9	25.8	32.7
1.9	3.9	4.8	5.3	8.0	2.7	4.9	18.6	18.7	25.2
3.0	0.6	1.9	2.8	5.1	1.0	2.3	8.2	6.6	17.5
4.2	0.2	1.3	1.3	2.7	0.1	1.1	4.9	0.5	11.9
5.3	0.0	0.7	0.9	0.5	0.0	0.4	2.2	0.0	8.1
6.4		0.0	0.1	0.0		0.0	0.0		3.6
7.6			0.0						0.5
8.7									0.0

* Denotes average of all data for indicated azimuth interval.

CONFIDENTIAL

CONFIDENTIAL

TABLE III

(Continued)

I:	230.2	230.3	230.2	242.5	242.3	242.4	242.2	242.2
	242.0	240.0	242.0	258.0	258.0	258.0	258.0	258.0
Q:	1800	2100		1320	1980	2040	3000	
<u>A</u>								
-21.7				99.8				
-20.6				99.8				
-19.4				99.8				
-18.3				99.8				
-17.2				99.7				
-16.1				99.5	98.9	99.9		
-14.9				99.1	98.4	99.8		
-13.8	96.9			98.8	98.3	99.6		
-12.7	95.4	91.5	93.7	97.7	97.7	99.6		
-11.6	93.7	89.5	91.5	97.3	97.1	99.1		
-10.4	91.8	87.3	89.4	96.1	96.2	99.0		
- 9.3	88.5	85.0	86.5	95.2	95.1	98.6	96.8	96.1
- 8.2	84.2	82.1	83.2	94.4	92.5	97.9	95.1	94.7
- 7.1	77.5	78.3	78.7	92.7	89.7	95.8	93.8	92.7
- 5.9	70.4	74.2	73.4	89.5	87.1	92.8	91.9	90.0
- 4.8	61.9	69.0	67.6	86.9	83.3	90.1	88.9	87.0
- 3.7	54.6	62.0	60.8	84.5	79.1	86.0	84.9	83.4
- 2.6	46.6	53.7	53.1	81.7	72.8	82.1	79.8	78.8
- 1.4	34.6	43.9	44.6	75.9	66.8	76.5	72.0	72.5
- 0.3	23.3	35.5	35.7	70.6	60.2	71.5	64.3	66.4
+ 0.8	15.0	28.5	27.0	61.9	51.8	65.5	58.8	59.5
1.9	7.8	22.1	19.1	54.0	43.0	57.5	51.2	51.4
3.0	3.4	14.9	10.8	43.1	34.1	49.3	44.3	42.7
4.2	1.0	8.0	5.5	35.9	25.6	42.2	36.6	34.9
5.3	0.0	3.7	2.8	30.9	19.0	33.3	28.7	28.0
6.4		1.0	0.9	22.2	9.9	24.8	22.2	19.8
7.6		0.0	0.1	16.0	6.8	15.1	18.0	14.0
8.7			0.0	13.3	3.3	7.9	11.7	9.2
9.8				10.0	3.2	6.9	9.1	7.3
10.9				4.9	2.1	3.7	6.7	4.3
12.0				2.9	1.5	2.4	5.5	3.0
13.2				1.0	0.0	1.2	2.3	1.1
14.3				0.7		0.6	1.9	0.8
15.4				0.0		0.0	1.5	0.4
16.5							0.6	0.2
17.7							0.0	0.0

* Denotes average of all data for indicated azimuth interval

CONFIDENTIAL

CONFIDENTIAL

TABLE II
(Continued)

I:	258.4	258.3	258.4	258.3	258.4	258.3	270.3	270.2	270.2
	270.0	270.0	270.0	270.0	270.0	270.0	203.0	283.0	285.0
Q:	2160	2160	2040	1320	1380		2150	2280	2100
<u>A</u>									
-17.2				99.9	99.9				
-16.1				99.8	99.8				
-14.9				99.4	99.8				
-13.8				99.1	99.8				
-12.7				99.9	99.8				
-11.6				98.4	99.8				99.9
-10.4				98.0	99.7		99.9	99.9	99.9
- 9.3	99.4	99.7	99.9	97.8	99.6	99.3	99.9	99.8	99.8
- 8.2	99.1	99.4	99.8	97.0	99.6	99.0	99.9	99.5	99.8
- 7.1	98.6	99.3	99.7	96.6	99.6	98.7	99.8	98.2	99.7
- 5.9	98.1	99.1	99.7	96.3	99.6	98.6	99.8	99.2	99.7
- 4.8	97.7	98.8	99.6	95.6	99.5	93.2	99.8	98.9	99.5
- 3.7	97.0	98.5	99.3	95.0	99.4	97.8	99.7	98.8	99.3
- 2.6	95.9	98.1	99.1	94.5	98.9	97.3	98.4	98.4	99.2
- 1.4	94.4	97.7	98.8	93.9	98.6	96.7	97.9	98.2	99.0
- 0.3	92.8	97.0	98.6	93.4	98.3	96.0	97.6	97.7	98.6
+ 0.8	91.4	96.6	97.9	92.6	97.9	95.3	97.3	97.2	98.0
1.9	89.3	95.2	97.3	92.2	97.2	94.2	96.7	96.6	96.8
3.0	86.8	94.1	96.7	91.5	96.9	93.2	96.2	96.1	94.9
4.2	84.4	92.6	95.0	89.7	96.5	91.7	95.7	95.4	93.7
5.3	82.0	89.9	92.7	84.1	95.9	88.9	95.2	94.9	91.0
6.4	79.8	87.7	91.0	78.4	94.7	86.3	94.6	94.1	89.4
7.6	78.2	83.3	89.3	72.8	93.0	83.3	93.3	93.5	86.5
8.7	74.9	80.2	87.5	67.0	91.3	80.2	91.1	92.2	83.5
9.8	71.3	76.4	85.7	62.3	89.5	77.0	88.7	90.8	81.3
10.9	67.5	72.9	83.5	58.7	83.8	73.3	86.3	88.3	77.8
12.0	63.5	65.4	80.7	52.5	80.4	68.5	83.4	84.6	73.9
13.2	55.3	59.6	75.9	46.4	77.4	62.9	81.0	77.1	69.2
14.3	50.2	53.1	70.4	40.9	73.7	57.7	77.6	68.8	62.6
15.4	45.0	46.6	64.9	32.3	65.7	50.9	74.8	59.8	56.0
16.5	41.0	40.1	53.9	22.6	60.5	43.5	68.1	50.8	46.9
17.7	36.4	31.8	43.2	12.4	47.6	34.3	60.2	42.2	39.2
18.8	31.2	24.3	38.8		39.0		54.3	33.3	34.6
19.9	28.3	19.0	32.7		24.0		49.2	25.0	28.1
21.0	24.1	13.9	24.3		11.0		42.9	15.9	21.5
22.1	19.8	9.8	20.3				36.1	9.9	15.6
23.3	16.6	6.6	15.4				28.9	3.9	9.1
24.4	12.5	2.8	8.7				22.8	1.3	5.3
25.5	9.9	0.7	4.3				11.5	0.9	0.9
26.7	6.4	0.5	0.9				3.3	0.5	0.1
27.8	1.4	0.0	0.0				1.8	0.0	0.0

* Denotes average of all data for indicated azimuth interval.

CONFIDENTIAL

CONFIDENTIAL

TABLE III
(Continued)

I:	270.5	270.2	283.3	283.3	283.2	283.2	293.2	300.2	300.3	300.2
	283.0	283.0	293.0	293.0	293.0	293.0	300.0	310.0	310.0	310.0
Q:	1320		1680	1740	1740		1320	2220	2340	
<u>A</u>										
-12.7	99.9	99.9								
-11.6	99.9	99.9								
-10.4	99.8	99.8			98.7					
- 9.3	99.7	99.7	99.4	98.7	98.1	98.7	99.2			
- 8.2	99.6	99.6	99.2	98.0	97.8	98.4	98.7			
- 7.1	99.6	99.5	99.0	97.6	97.3	98.0	97.8	94.9	97.1	96.5
- 5.9	99.4	99.5	98.6	97.0	96.5	97.4	96.8	92.9	95.5	94.7
- 4.8	99.1	99.3	97.4	96.4	95.8	96.5	95.1	90.4	93.4	92.3
- 3.7	99.0	99.1	96.2	95.2	94.4	95.3	91.9	86.9	90.5	89.2
- 2.6	98.7	98.6	94.6	92.9	93.2	93.6	88.4	83.2	87.5	85.3
- 1.4	98.5	98.4	93.4	90.5	91.7	91.9	82.5	80.0	84.7	82.3
- 0.3	97.8	97.9	90.8	88.1	89.3	89.4	77.7	77.3	81.1	79.2
+ 0.8	97.1	97.3	88.3	85.7	86.3	86.7	74.1	73.6	77.8	75.7
1.9	94.7	96.2	85.0	83.0	84.4	84.1	70.8	67.0	73.0	70.0
3.0	92.8	95.0	81.4	79.8	81.6	80.9	66.2	58.5	66.7	62.6
4.2	90.0	93.7	73.7	76.8	77.5	76.0	62.2	48.4	58.6	53.5
5.3	86.3	91.8	66.3	72.4	73.2	70.6	55.4	40.1	49.3	44.7
6.4	82.5	90.1	58.4	67.0	67.6	64.4	44.8	31.5	39.6	35.5
7.6	78.7	88.0	51.9	59.0	60.6	57.2	34.9	23.7	29.3	26.5
8.7	76.3	85.8	44.6	48.0	52.3	48.3	27.6	15.4	19.6	17.5
9.8	70.9	82.9	36.7	36.3	45.8	39.6	23.5	9.4	12.3	10.8
10.9	64.3	79.2	31.4	30.2	38.7	33.4	17.0	5.3	5.2	5.3
12.0	59.4	75.3	23.1	24.9	29.8	25.9	11.7	2.2	1.1	1.6
13.2	54.5	70.4	16.5	18.4	19.9	18.2	5.1	0.4	0.1	0.3
14.3	47.3	64.1	12.0	6.5	6.8	8.5	3.4	0.3	0.0	0.1
15.4	38.2	57.2	6.5	6.2	3.9	5.5	2.8	0.1		0.0
16.5	31.6	49.3	4.2	2.6	0.7	2.5	1.2	0.1		
17.7	23.7	41.3	1.9	0.7	0.1	0.9	0.0	0.0		
18.8			0.6	0.0	0.0	0.2				
19.9			0.2			0.1				
21.0			0.0			0.0				

* Denotes average of all data for indicated azimuth interval.

CONFIDENTIAL

CONFIDENTIAL

TABLE III

2813 Mc/s

Probability (X100) of $\Lambda = 10 \log_{10} \sigma$ (σ in square meters)
for Azimuth Intervals I (I in degrees) and Sample Size Q
(Q in number of pulses). $Q/60$ = Length of Sample in Seconds.

I:	37.5	37.5	37.5	37.5	37.5	37.5	Average	Variances
Q:	45.0	45.0	45.0	45.0	45.0	45.0		
	1080	1200	1200	1320	1800	1950		
<u>A</u>								
-21.7	0.09							
-20.6	0.09							
-19.4	0.09							
-18.3	0.09		0.08					
-17.2	0.64		0.42					
-16.1	0.64		0.25					
-14.9	0.18	0.08	0.16					
-13.8	0.74	0.42	0.42	0.38				
-12.7	0.00	0.67	0.42	0.60	0.72			
-11.6	0.46	1.25	0.42	0.15	1.11			
-10.5	0.23	1.00	0.75	1.97	0.94			
- 9.3	0.46	2.33	0.83	1.51	1.61	1.87	1.43	0.40
- 8.2	0.92	1.83	0.91	1.06	4.56	1.82	1.85	1.62
- 7.1	0.64	2.33	1.33	3.10	3.06	2.22	2.16	0.80
- 5.9	0.64	2.58	1.33	2.58	4.78	2.78	2.45	1.68
- 4.8	1.48	3.75	2.33	3.48	4.05	2.86	3.00	0.78
- 3.7	1.94	3.83	3.92	1.82	4.78	3.33	3.27	1.15
- 2.6	3.33	5.50	3.92	0.98	5.33	3.43	3.75	2.25
- 1.4	8.33	5.33	7.92	1.59	5.61	8.53	6.21	5.88
- 0.3	7.78	4.08	10.75	2.04	5.11	9.09	6.47	9.01
+ 0.8	9.28	2.92	13.99	4.70	5.11	7.47	7.25	13.22
1.9	5.46	3.50	11.49	5.30	3.67	8.33	6.29	7.92
3.0	11.02	4.60	8.75	8.48	5.22	8.43	7.76	4.35
4.2	9.91	4.92	8.25	13.10	9.06	7.57	8.80	6.11
5.3	7.96	11.75	8.16	14.31	13.11	9.29	10.76	5.95
6.4	2.68	16.50	8.58	17.35	5.67	5.20	9.33	31.83
7.6	3.42	17.08	3.91	6.56	3.94	9.09	7.67	22.91
8.7	7.03	2.25	0.42	1.59	6.72	3.08	3.52	6.28
9.8	9.72	1.42	0.00	4.01	1.05	1.61	2.87	10.39
10.9	4.63	0.00		0.68	1.05		1.06	2.71
12.0	0.00			0.00	1.06		0.17	0.16
13.2					0.44		0.07	0.08
14.3					0.00		0.00	

CONFIDENTIAL

CONFIDENTIAL

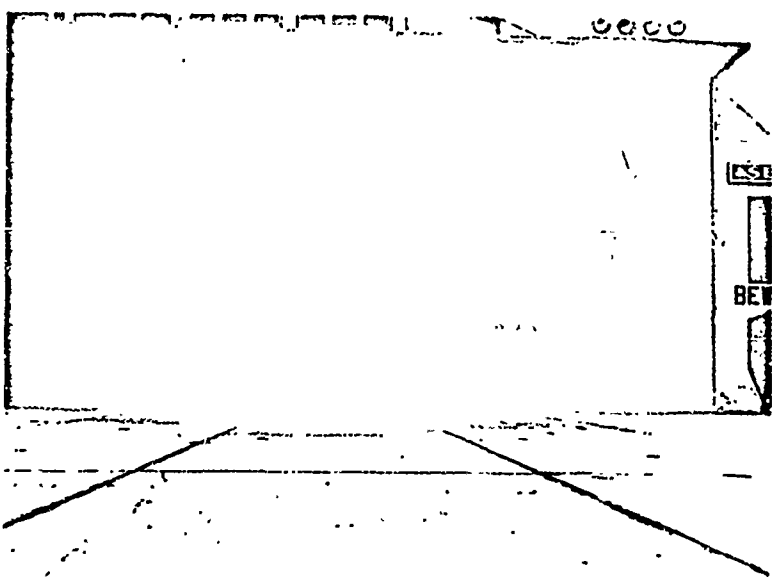
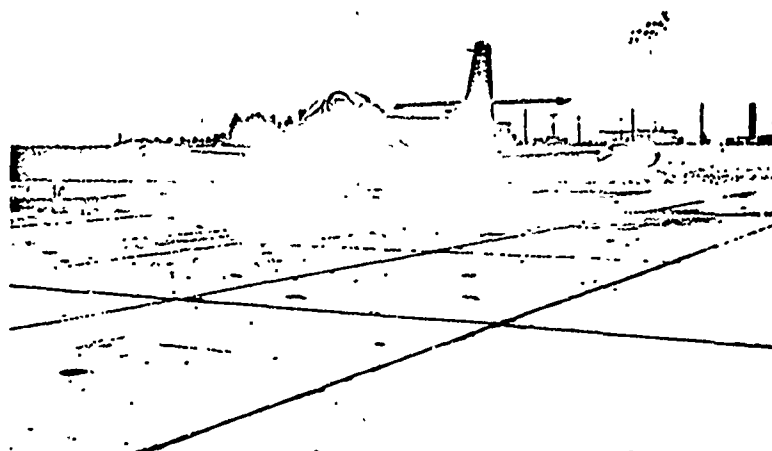

CONFIDENTIAL

Figure 1

CONFIDENTIAL

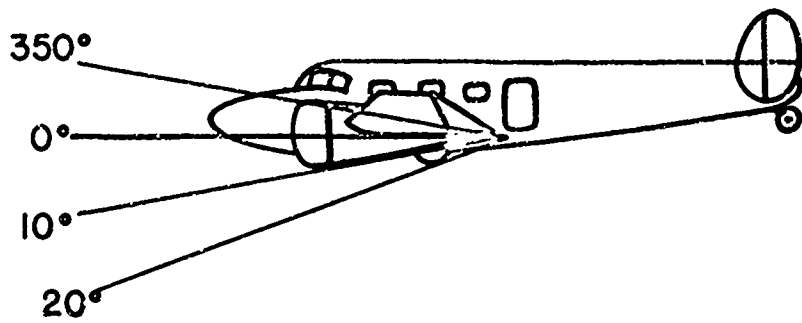
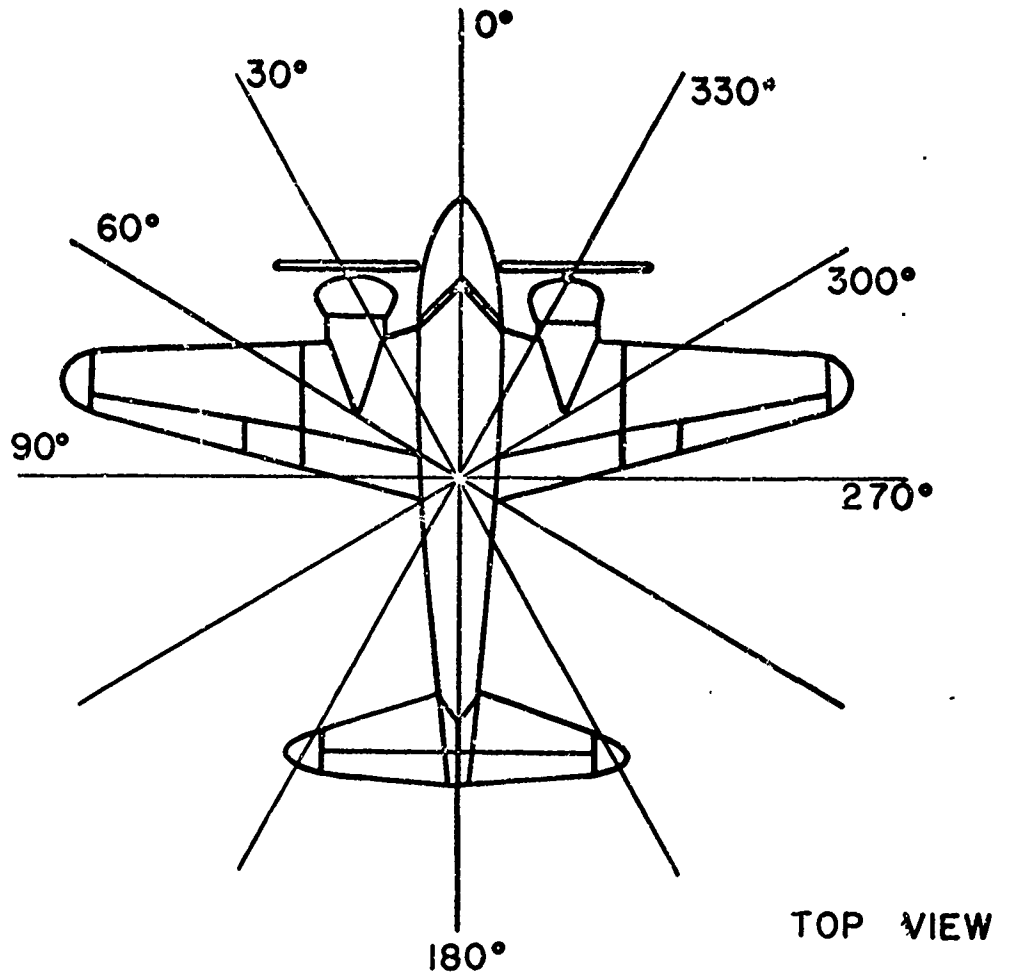

Definition of aspect angles

CONFIDENTIAL

Figure 2

CONFIDENTIAL

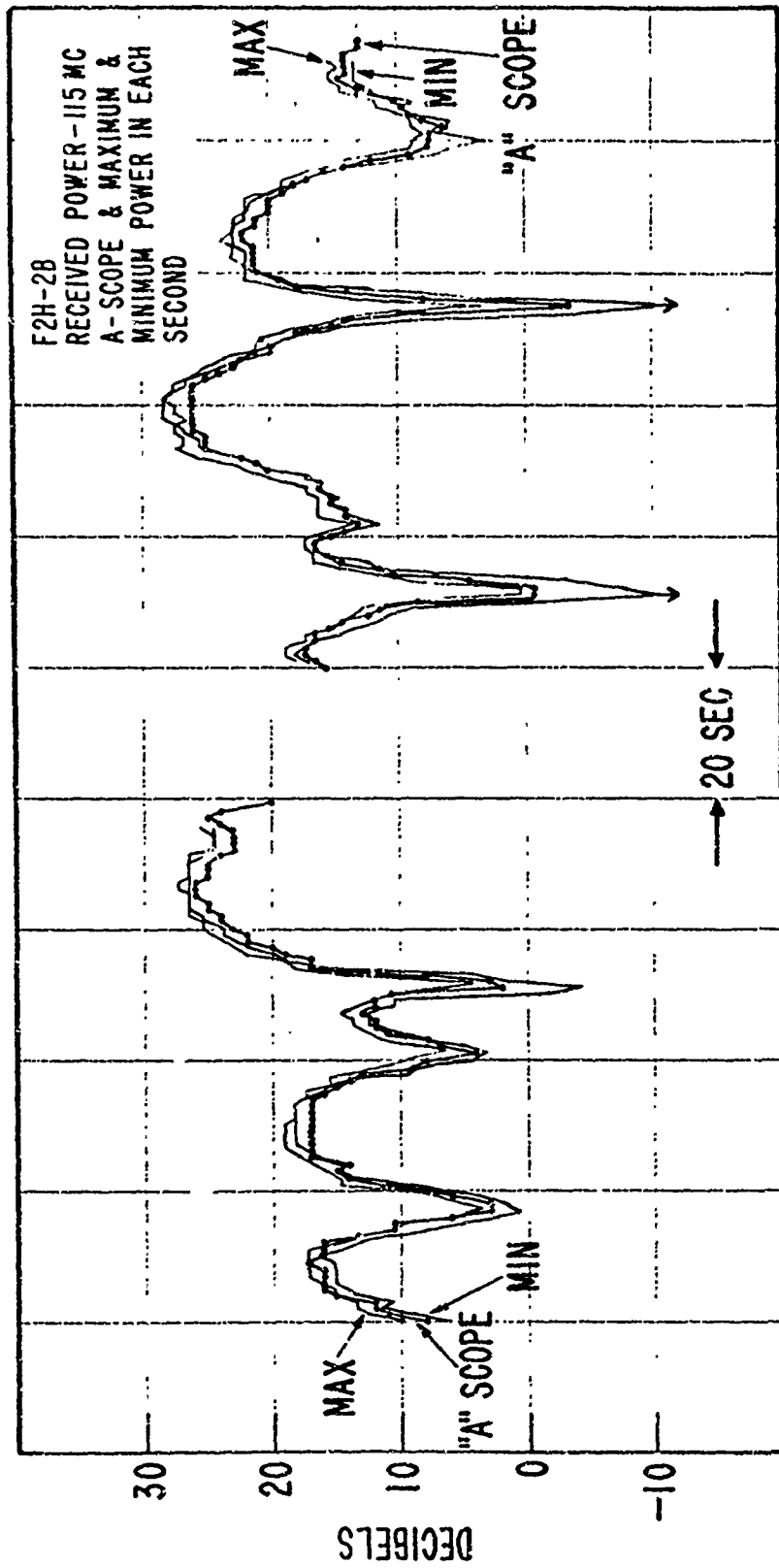

CONFIDENTIAL

Figure 3

CONF

ASPECT

3

$10 \log_{10} [\sigma \text{ IN SQUARE METERS}]$

480 500 520 540 560 580 600 620 640 660 680

CON

FIGURE 4

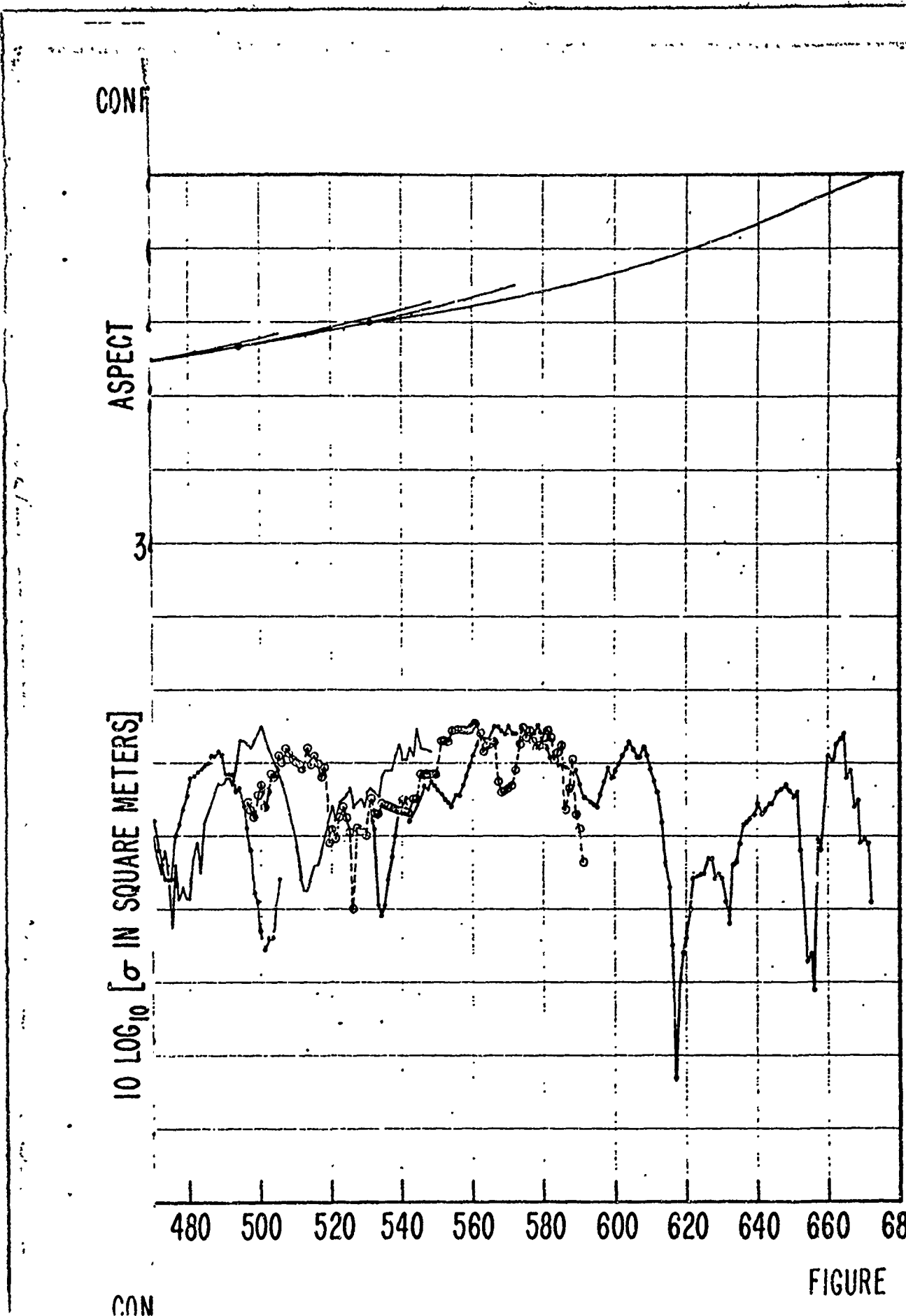

CONFIDENTIAL

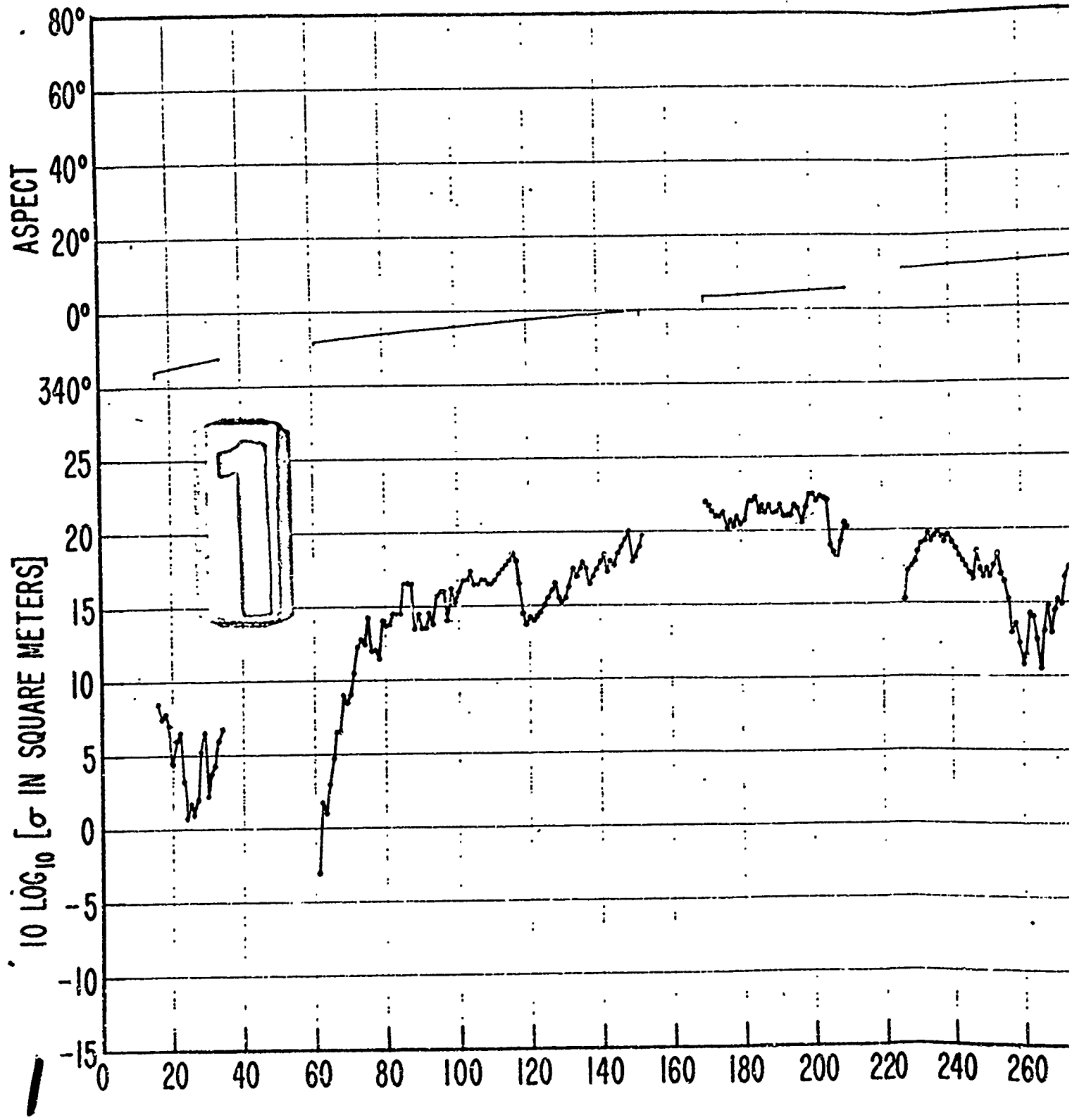

F2H-2B
115 MC

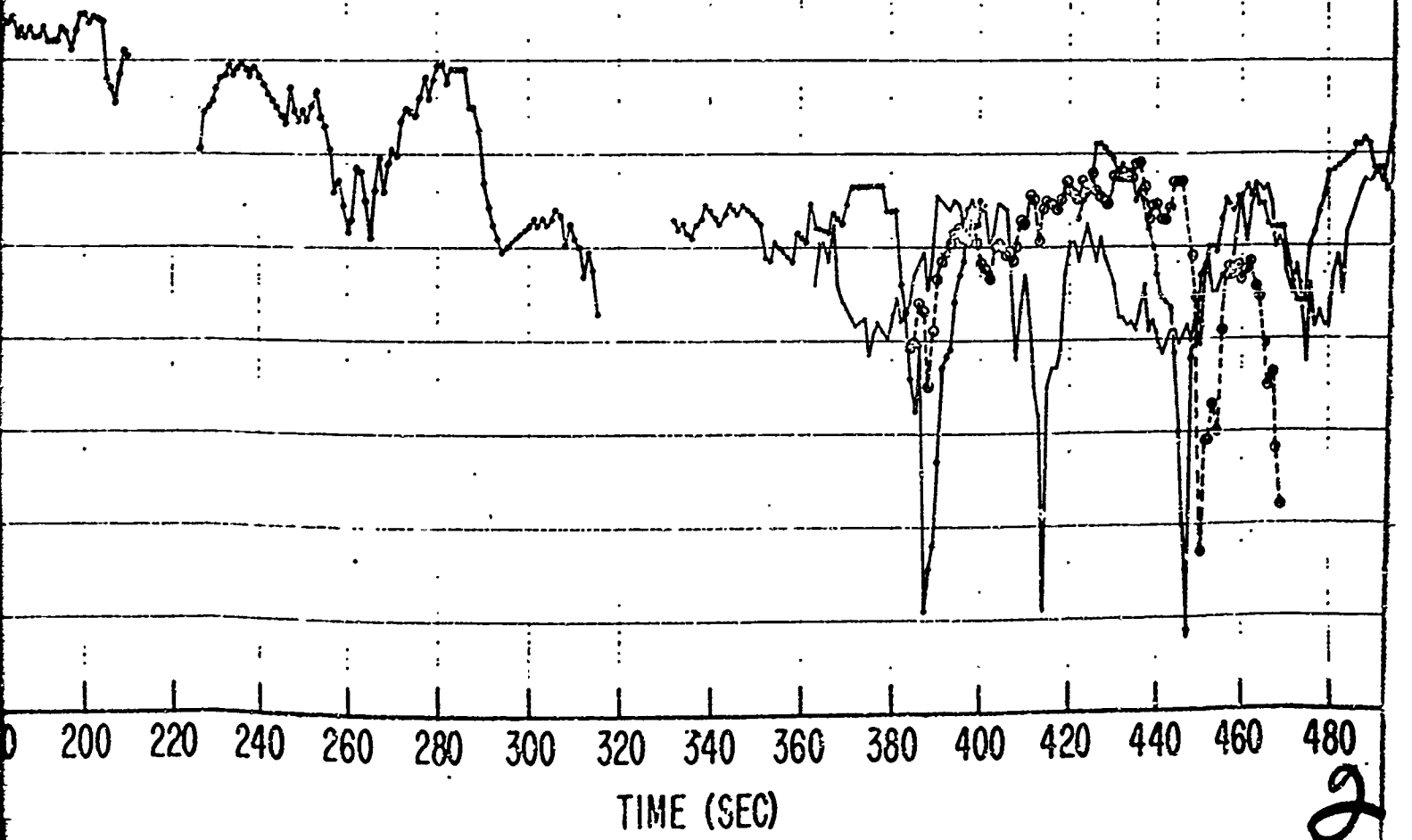

F2H-2B
115 MC

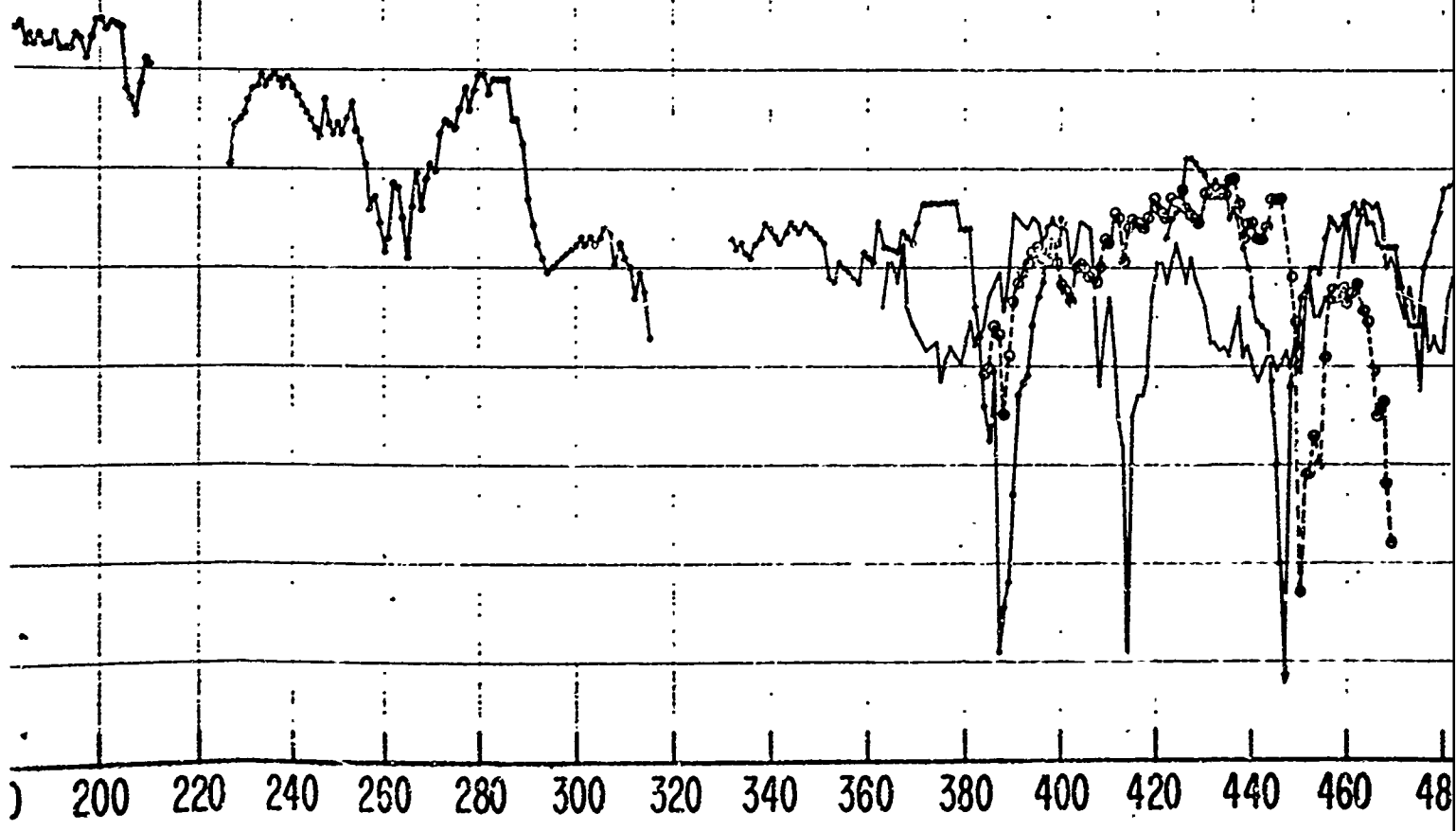

TIME (SEC)

/

F2H-2B
115 MC

2

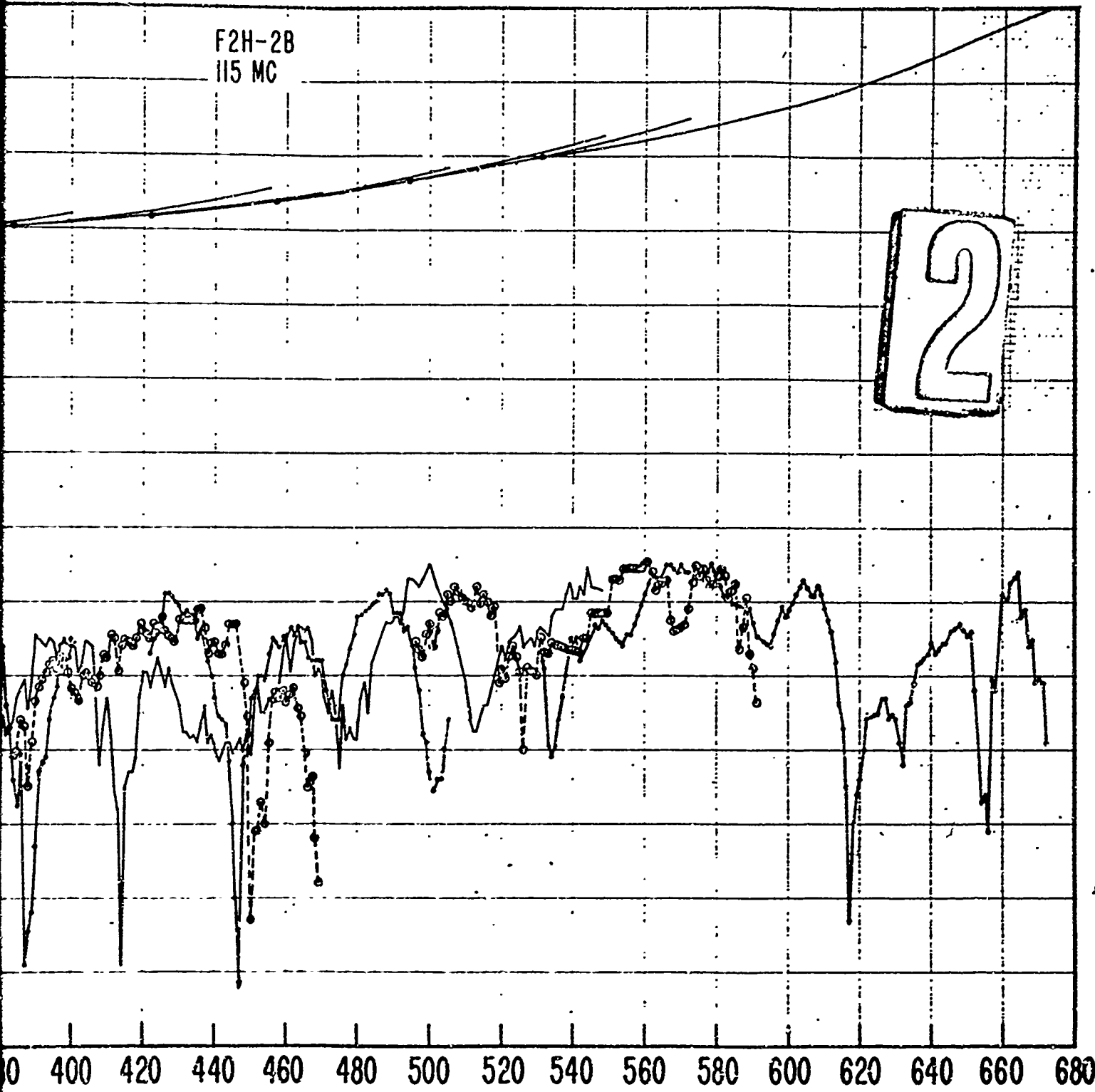

2 FIGURE 4

CONF

ASPECT

3

10 LOG₁₀ [σ IN SQUARE METERS]

480 500 520 540 560 580 600 620 640 660 680

CONF

FIGURE 4

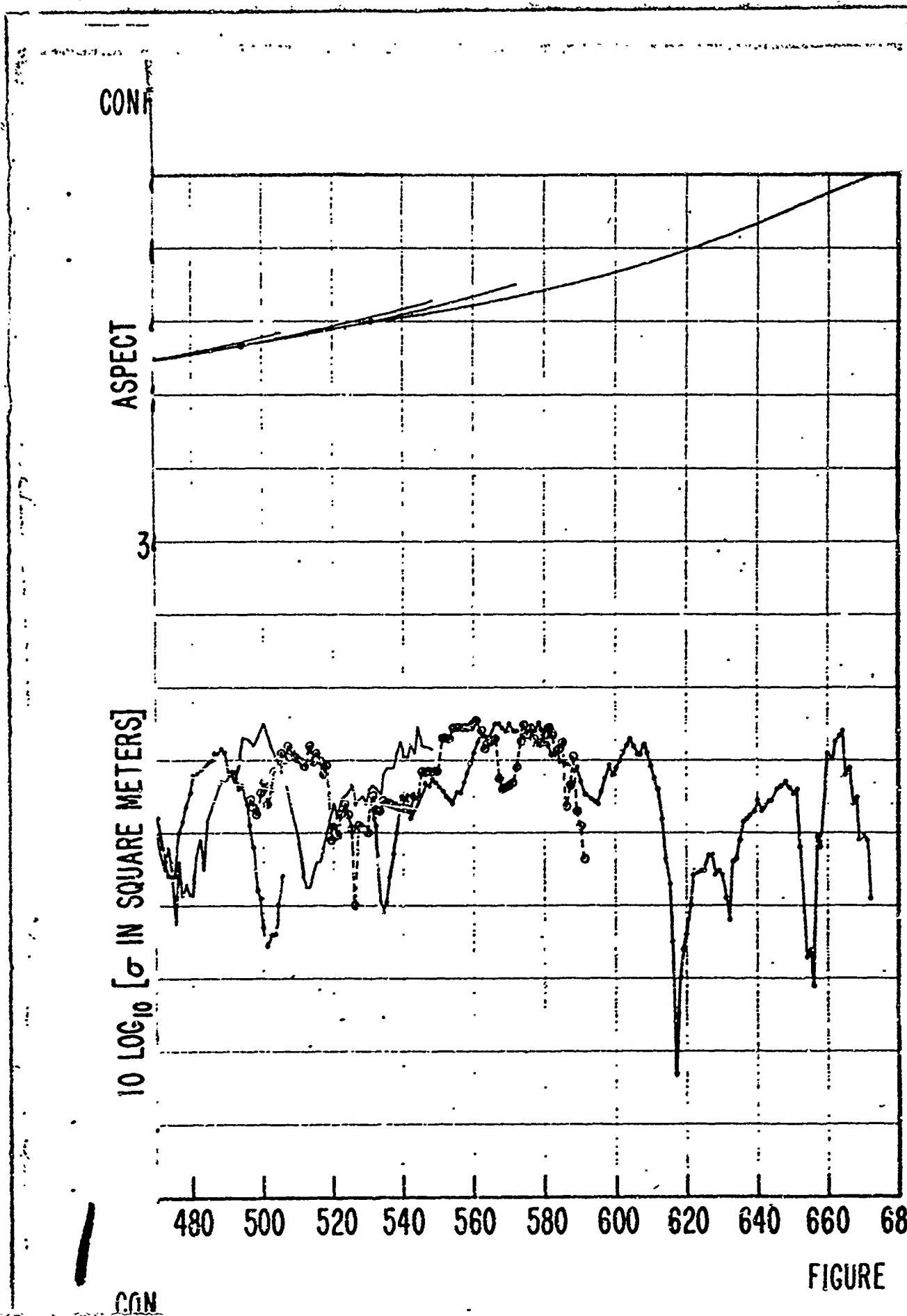

CONFIDENTIAL

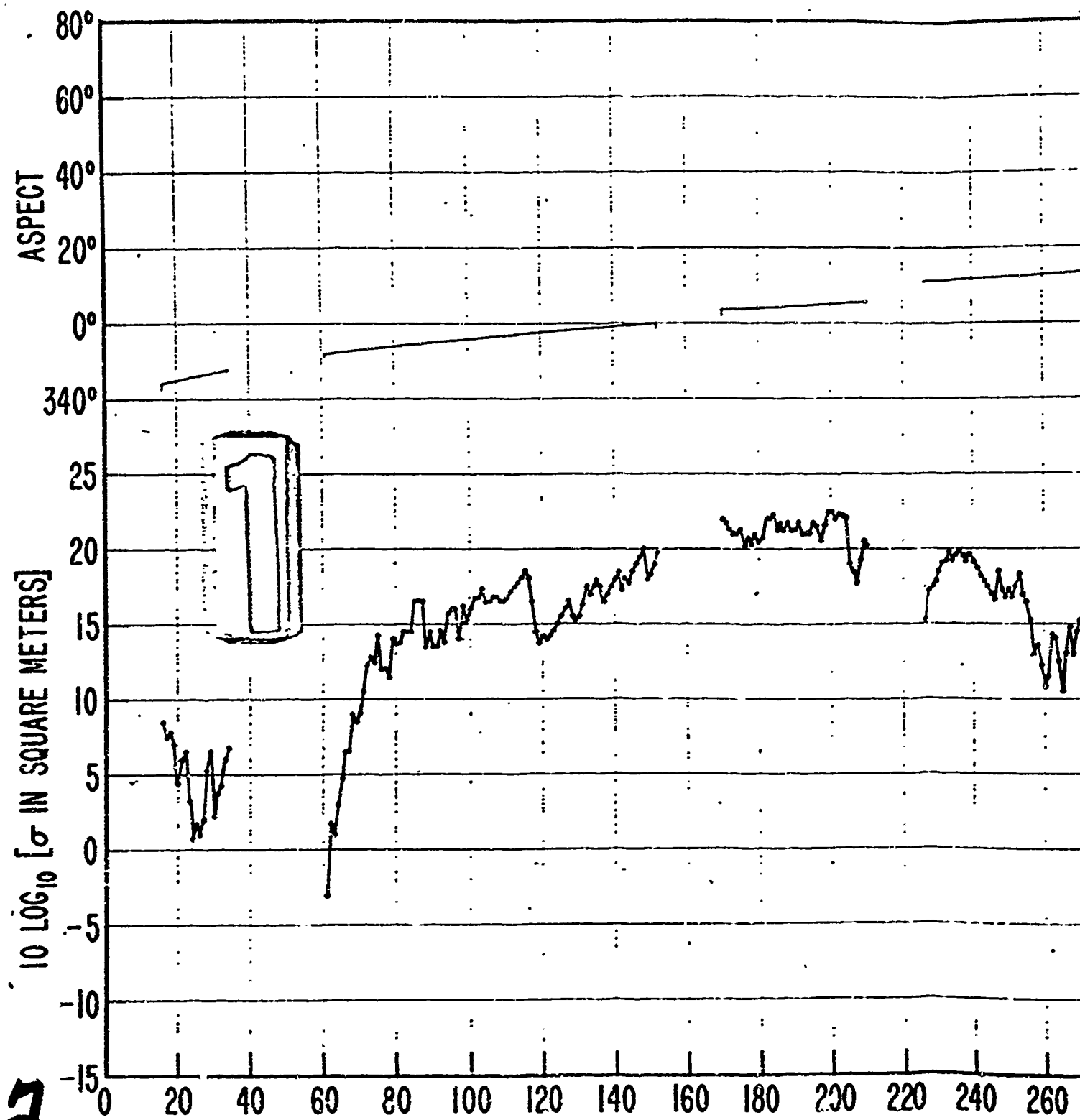

2

F2H-2B
115 MC

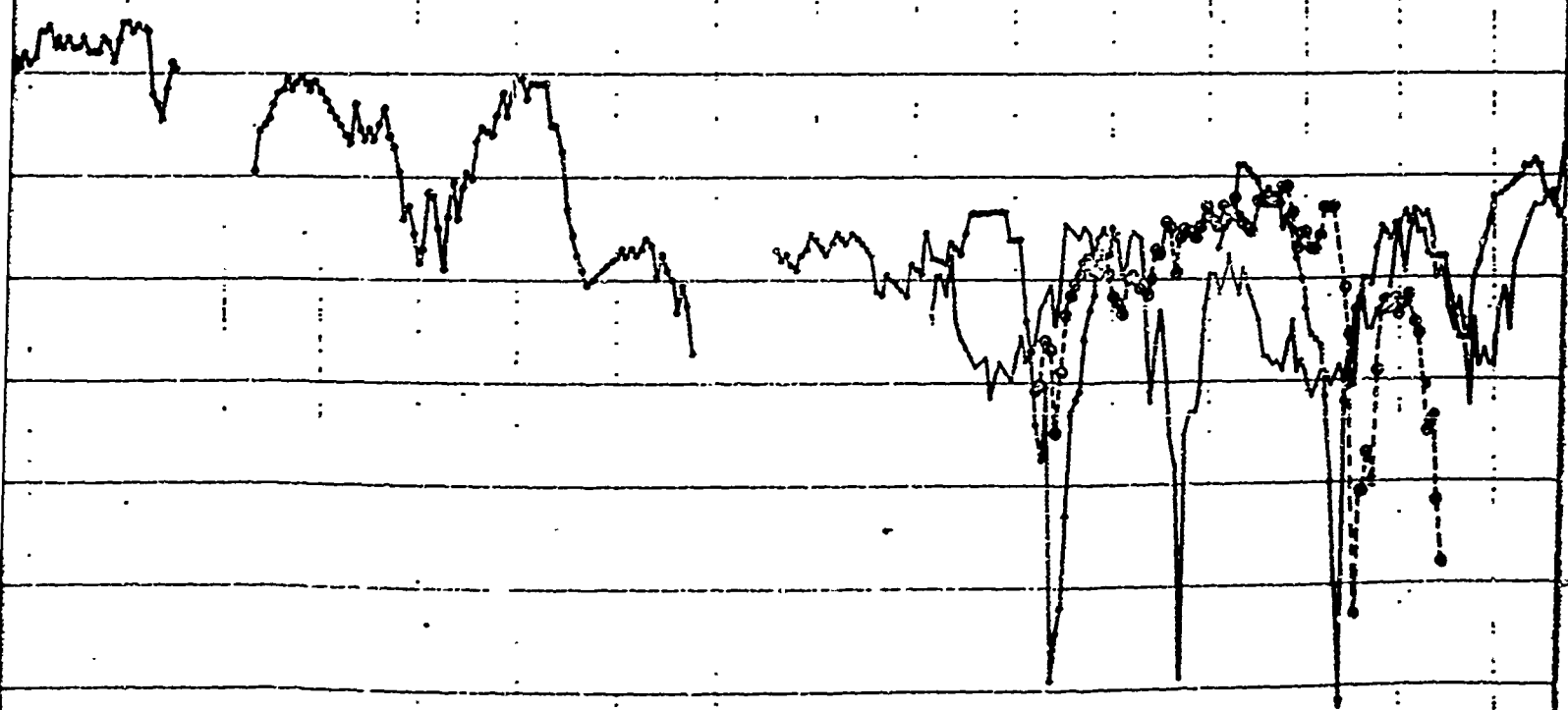

180 200 220 240 260 280 300 320 340 360 380 400 420 440 460 480

TIME (SEC)

2

F2H-28
115 MC

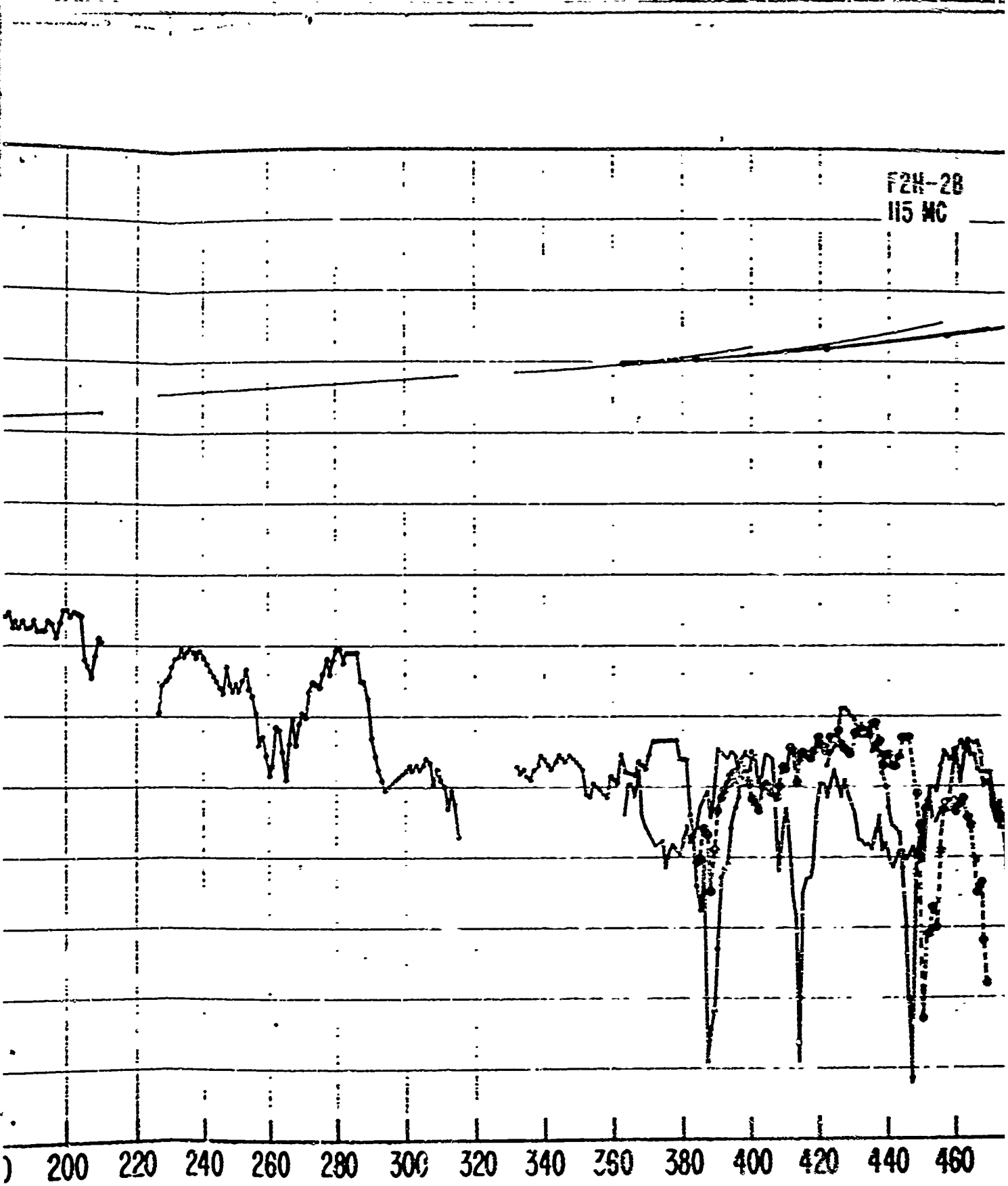

TIME (SEC)

4

F2H-2B
115 MC

2

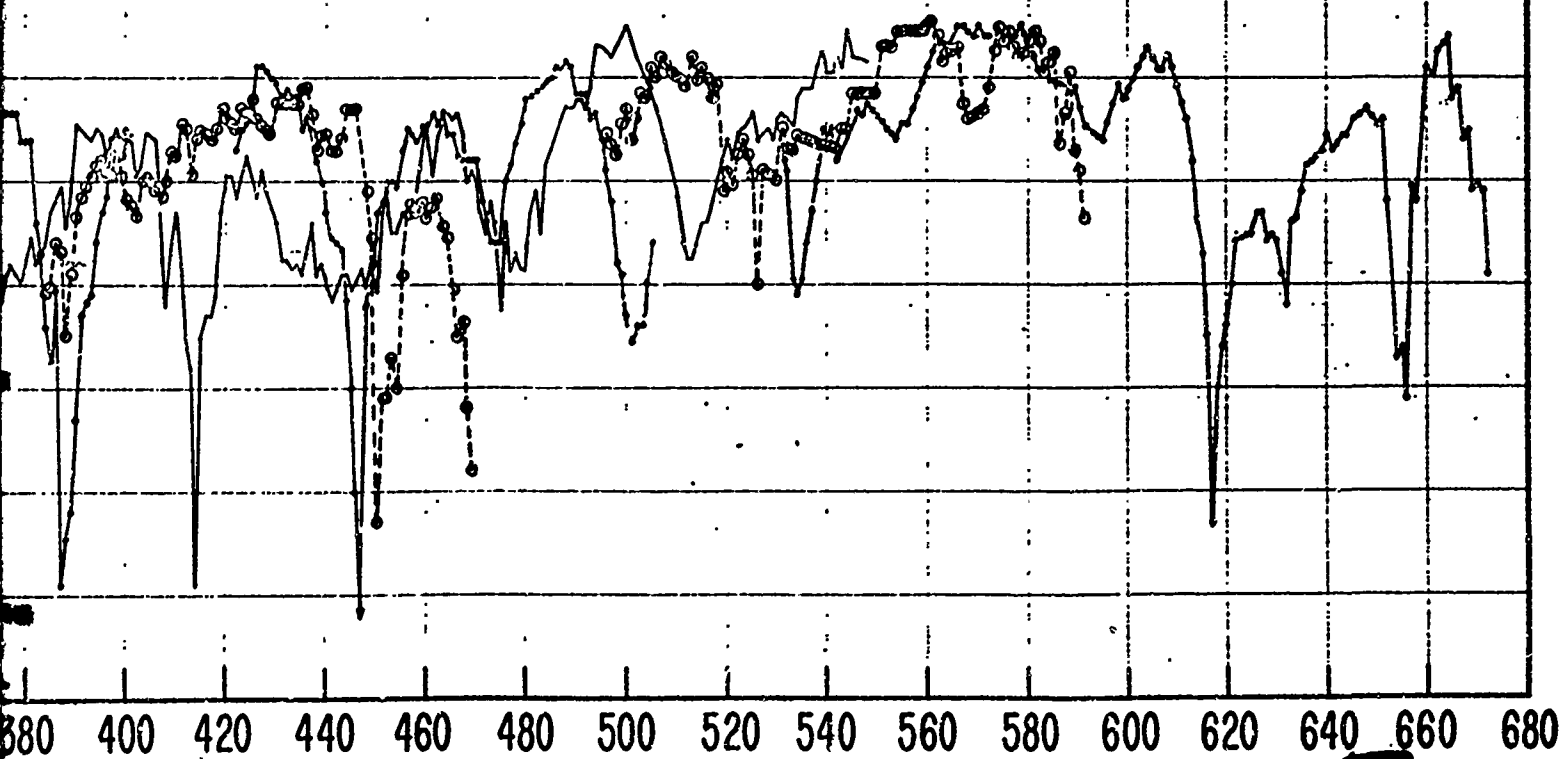

2 FIGURE 4

CONFIDENTIAL

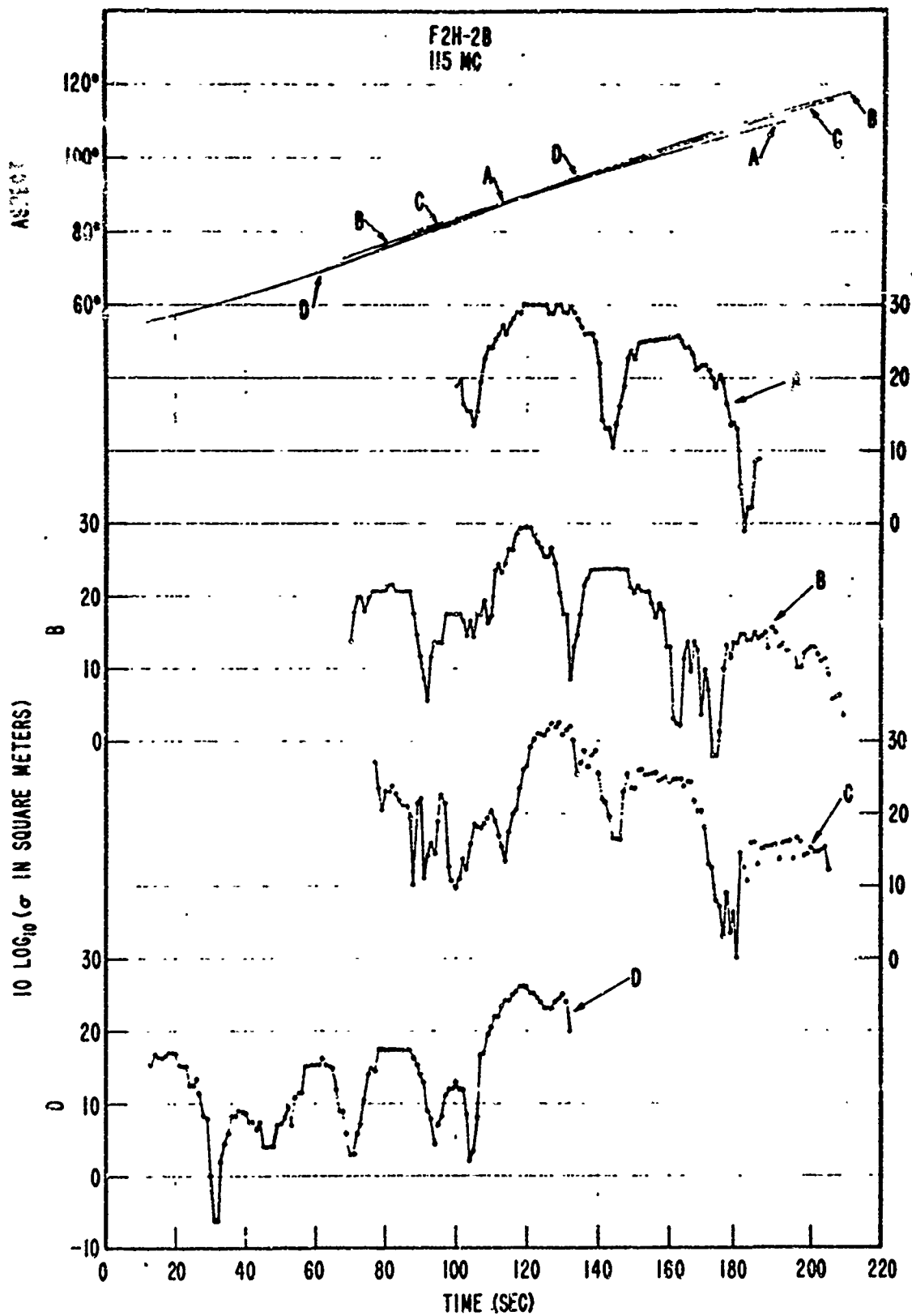

CONFIDENTIAL

Figure

10 LOG₁₀ (σ IN SQUARE METERS)

5

CONFIDENTIAL

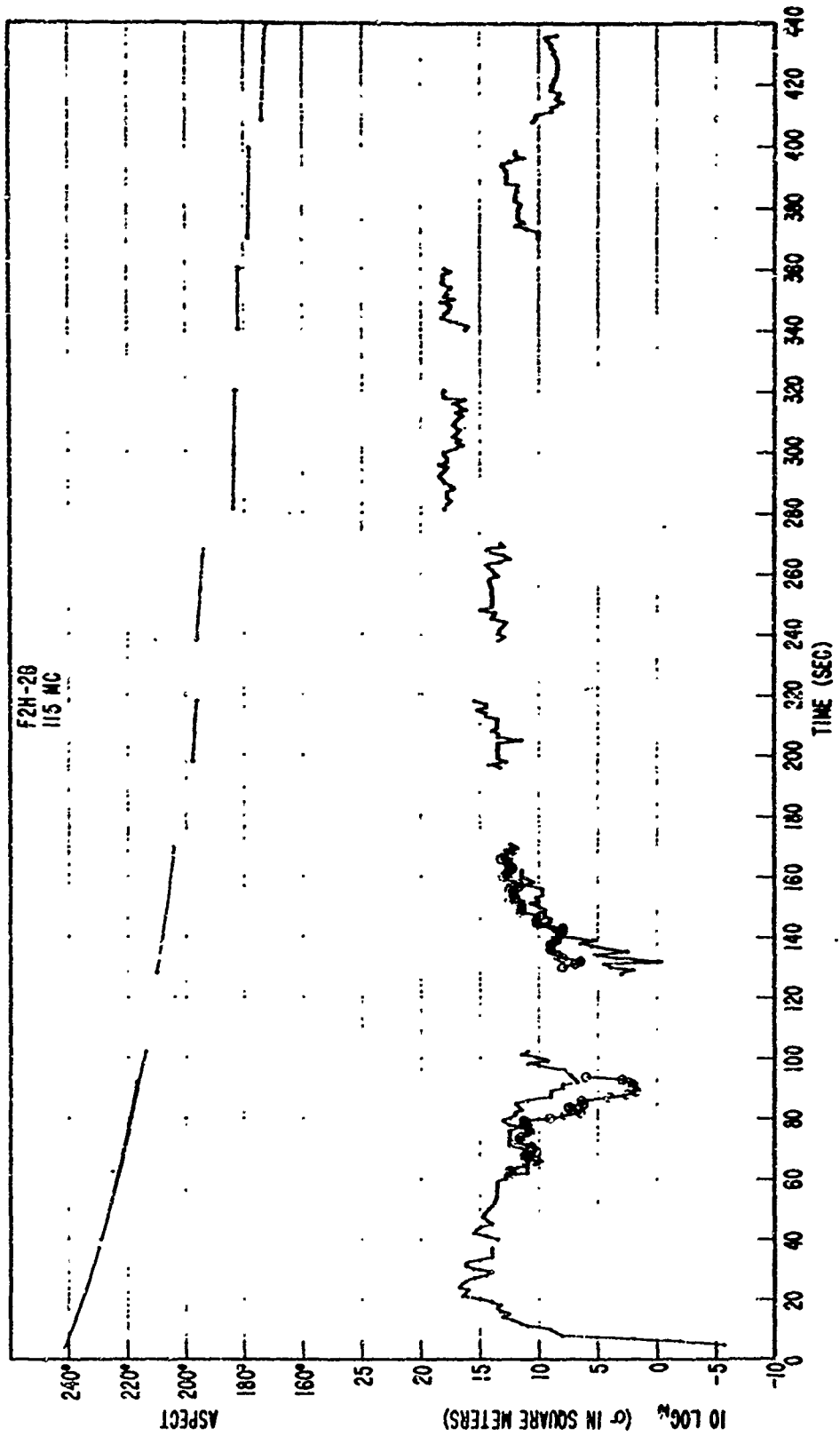

CONFIDENTIAL

Figure 6

CONFIDENTIAL

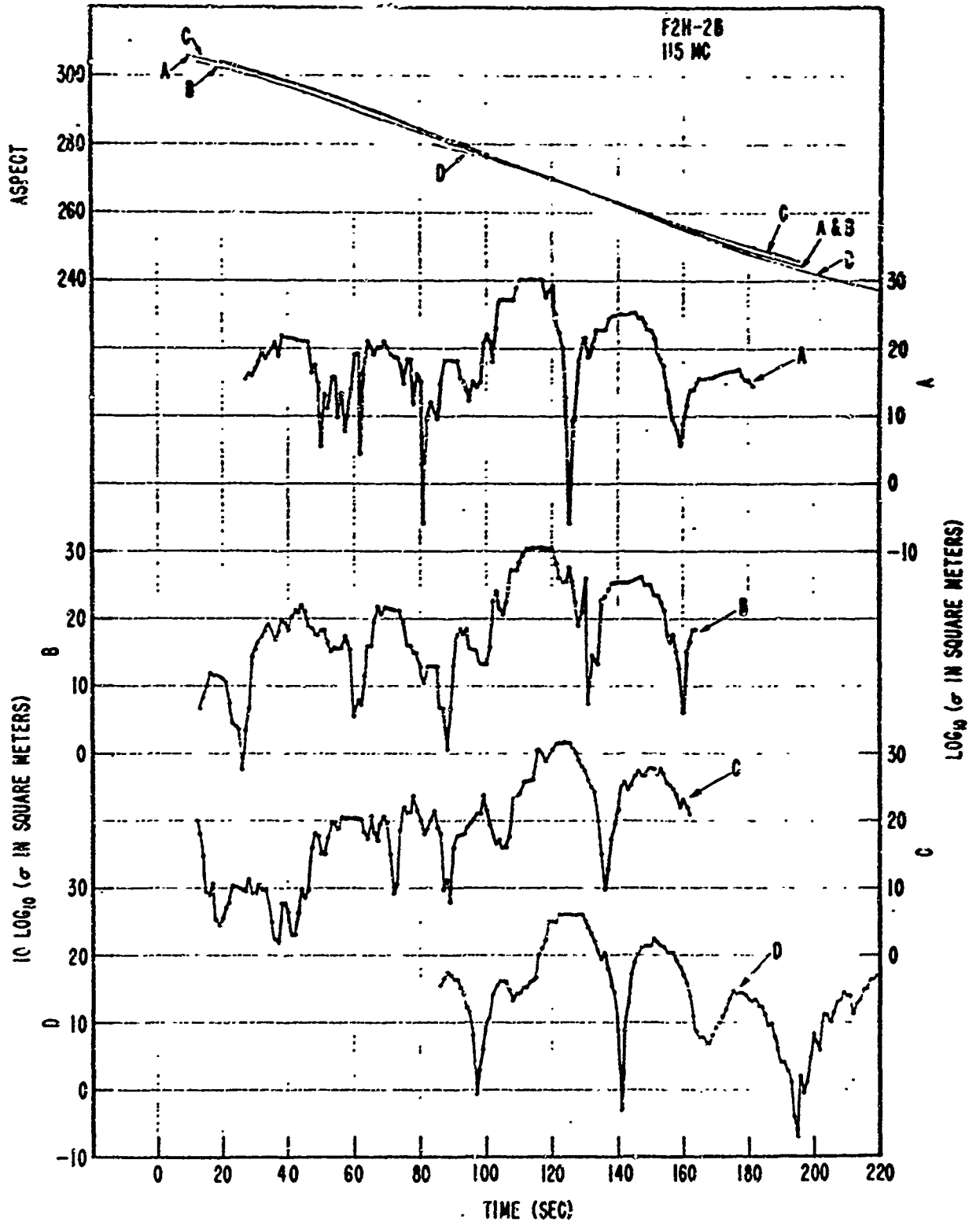

CONFIDENTIAL

Figure 7

CONFIDENTIAL

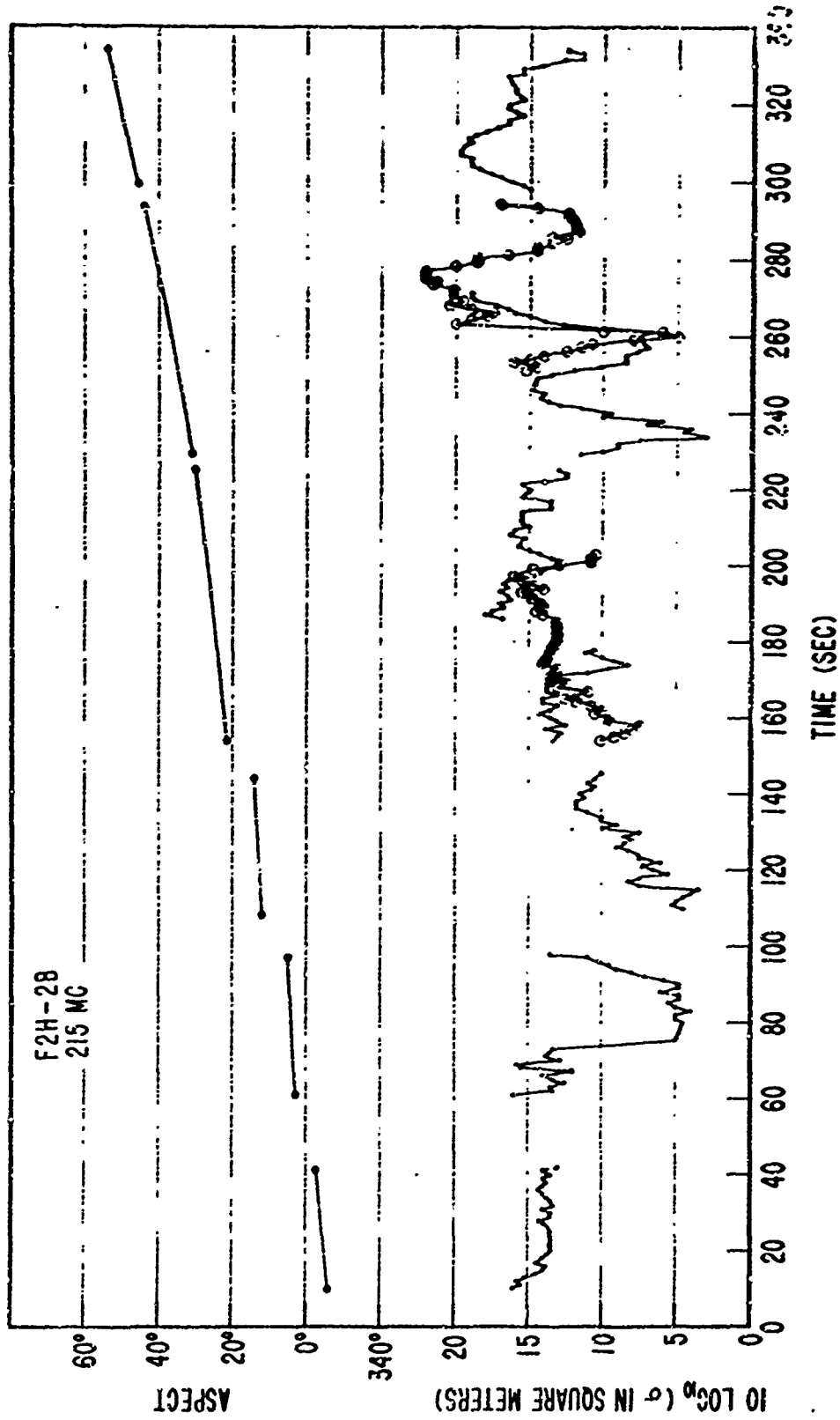

CONFIDENTIAL

Figure 8

CONFIDENTIAL

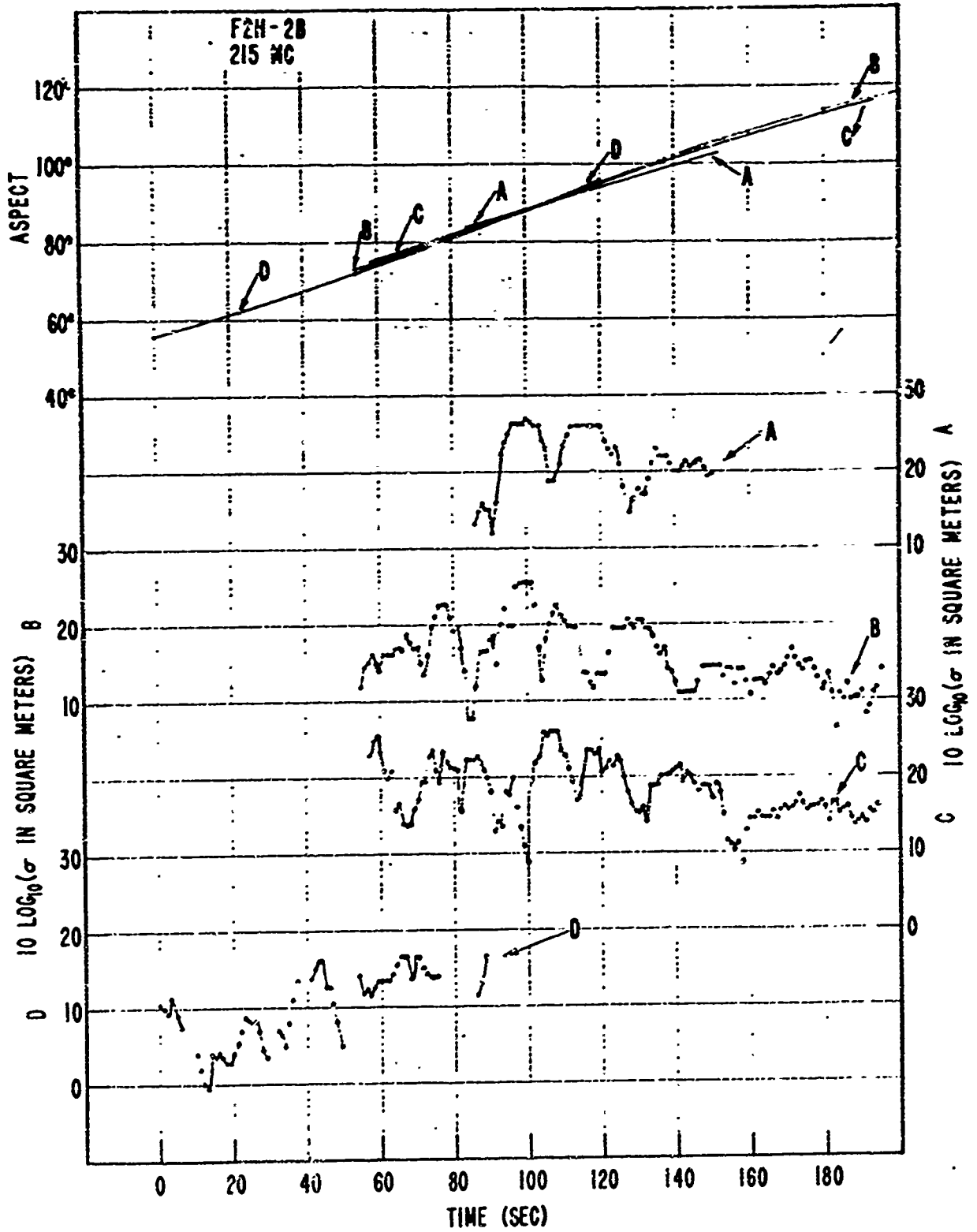

CONFIDENTIAL

Figure 9

CONFIDENTIAL

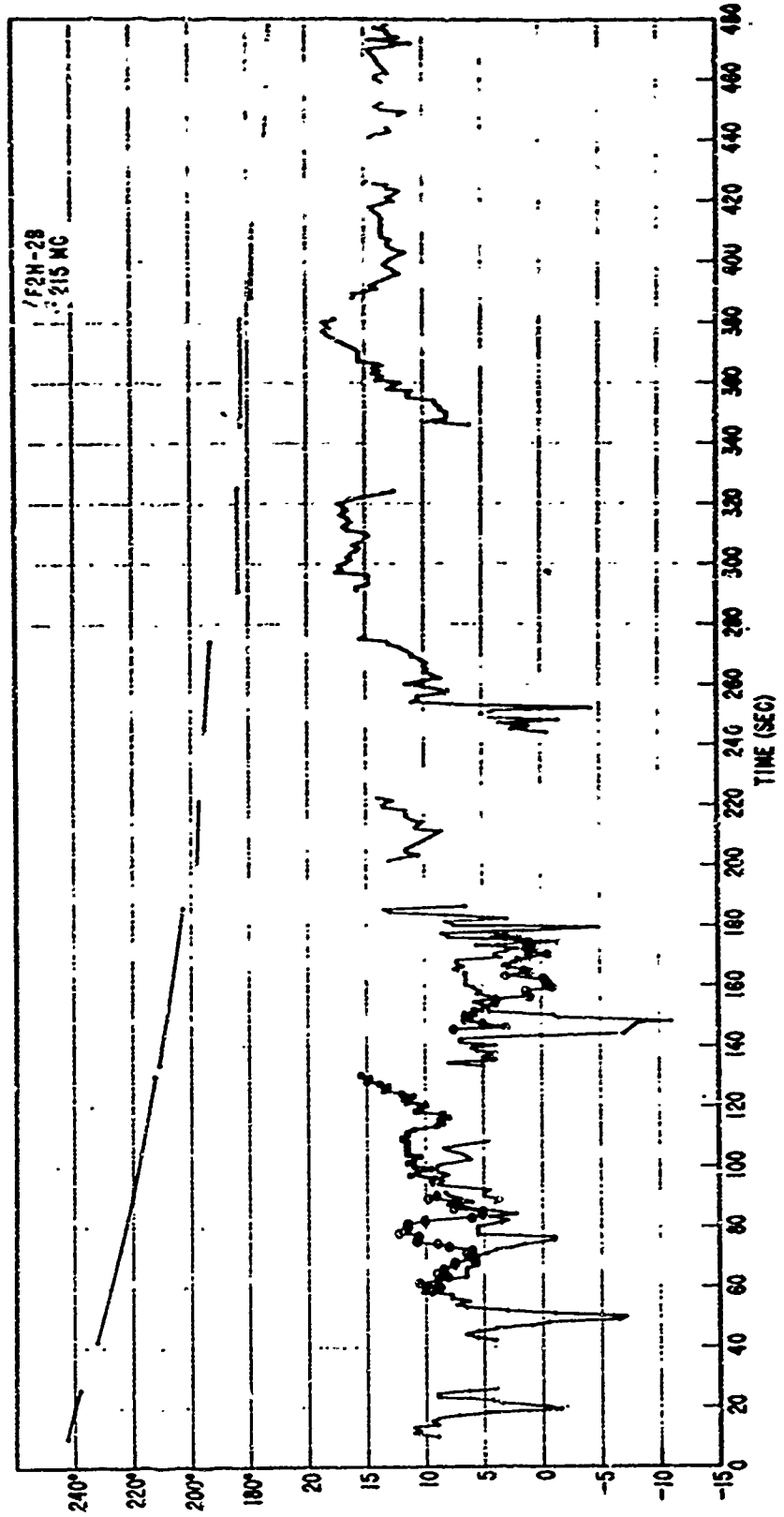

CONFIDENTIAL

Figure 19

CONFIDENTIAL

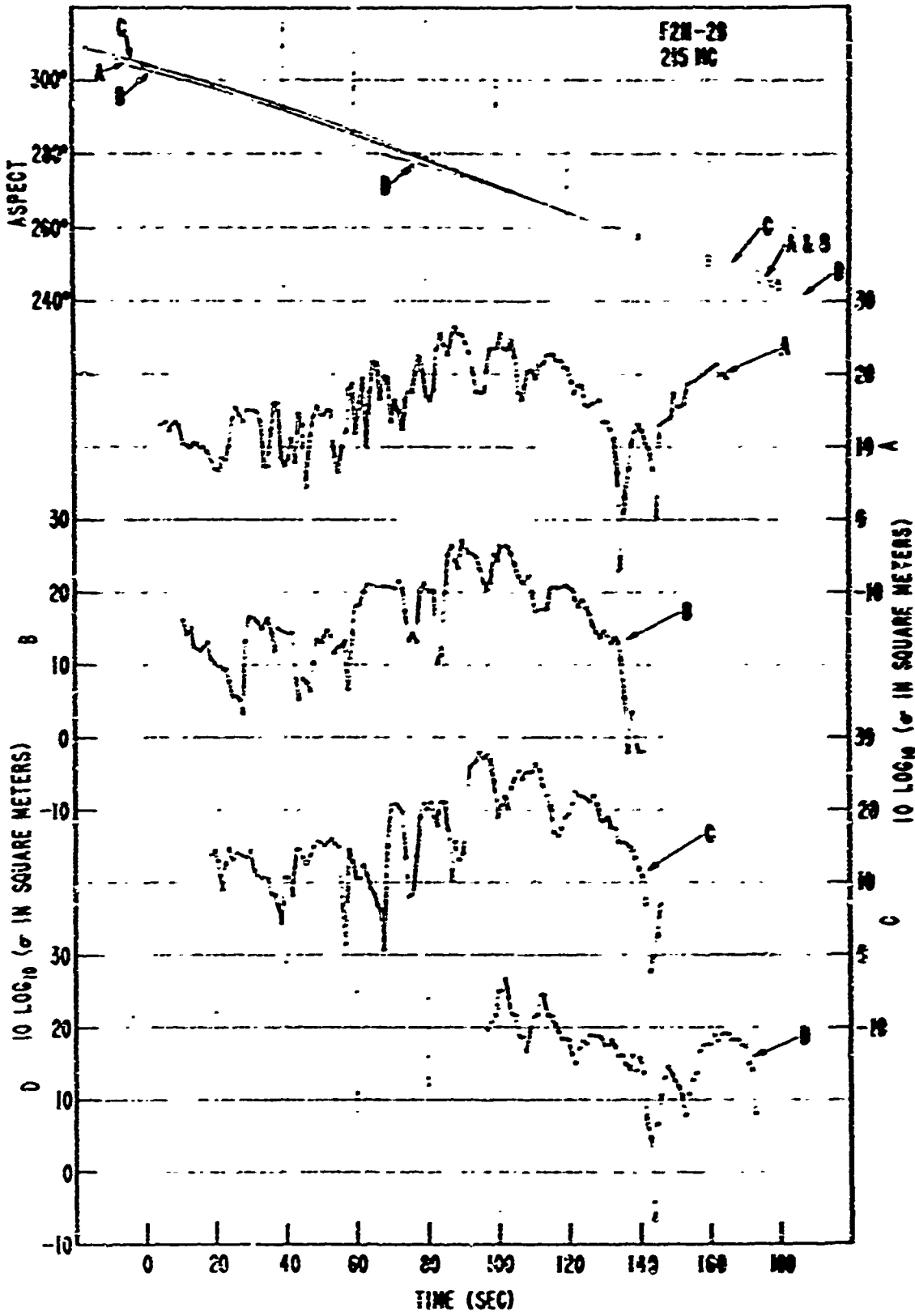

CONFIDENTIAL

Figure 11

CONFIDENTIAL

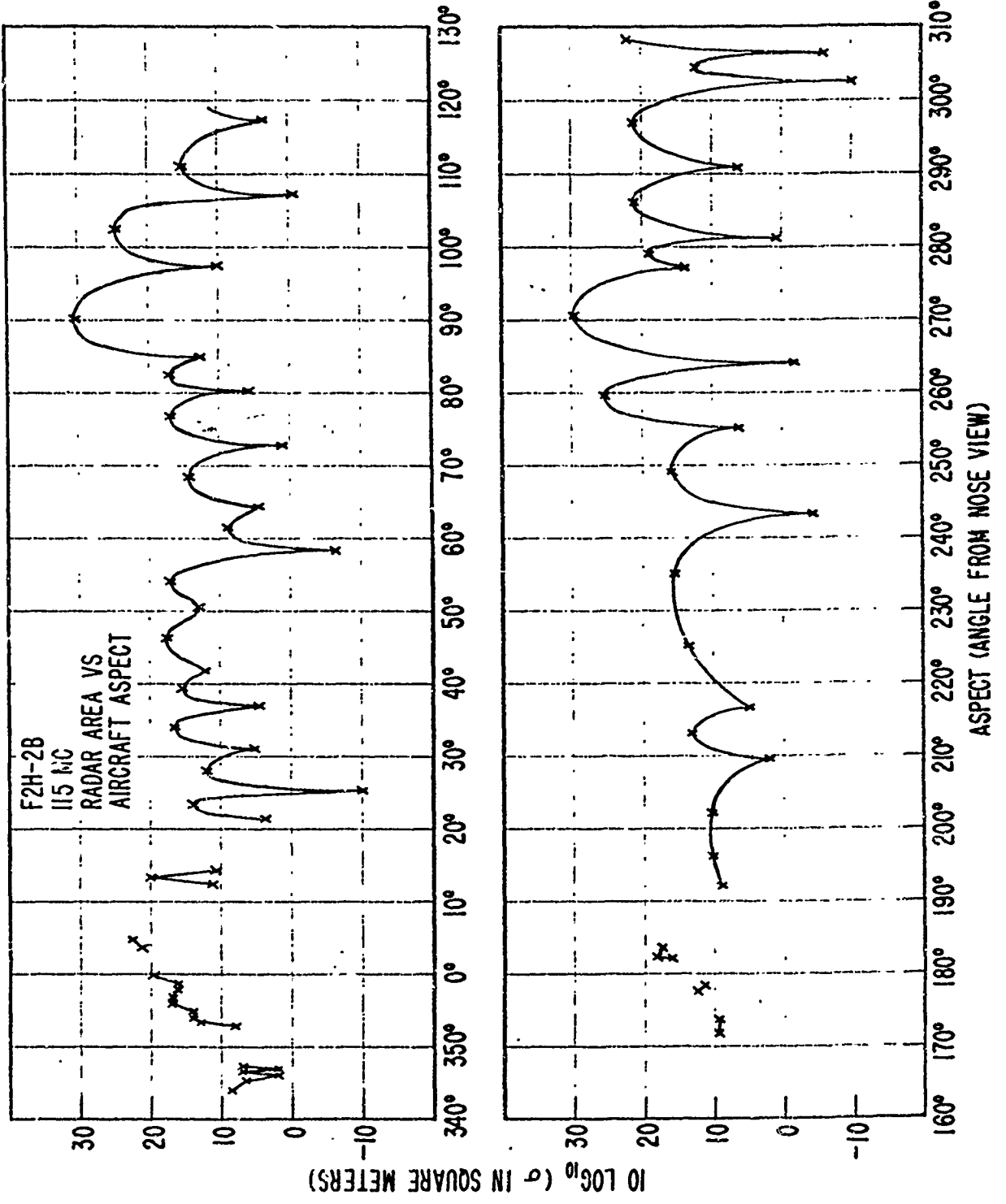

CONFIDENTIAL

Figure 12

CONFIDENTIAL

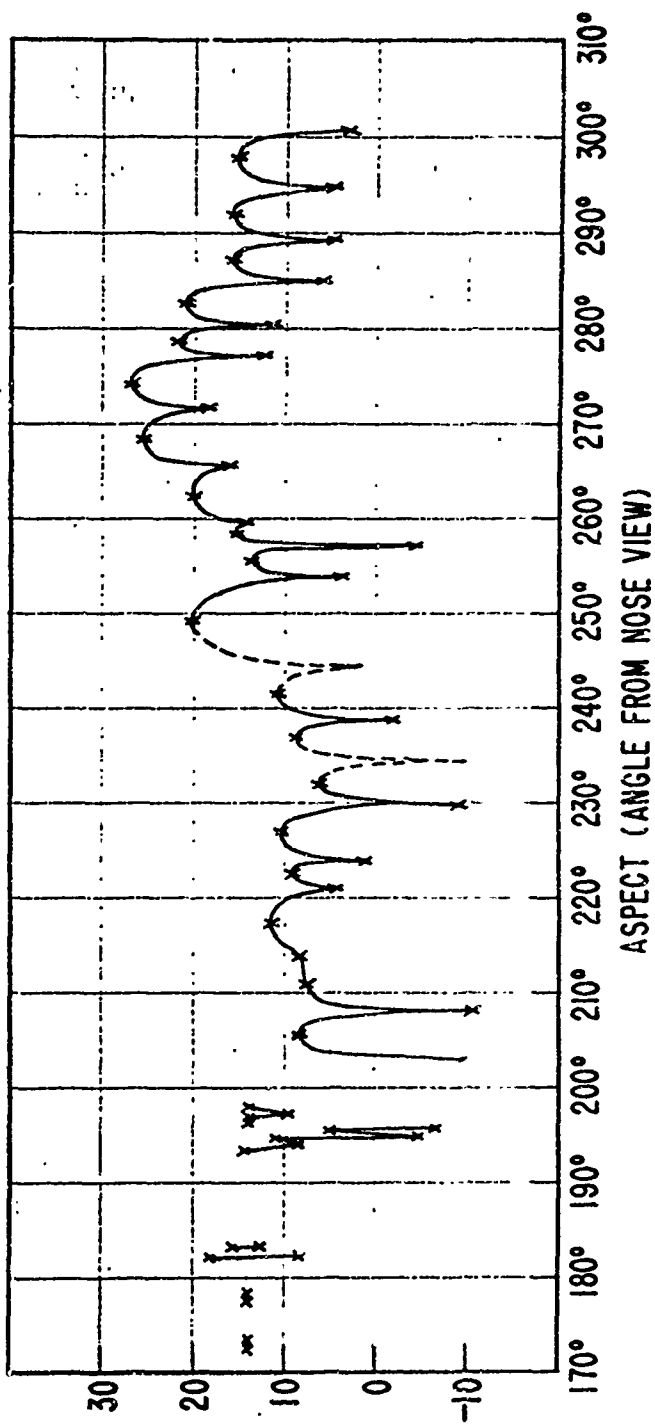
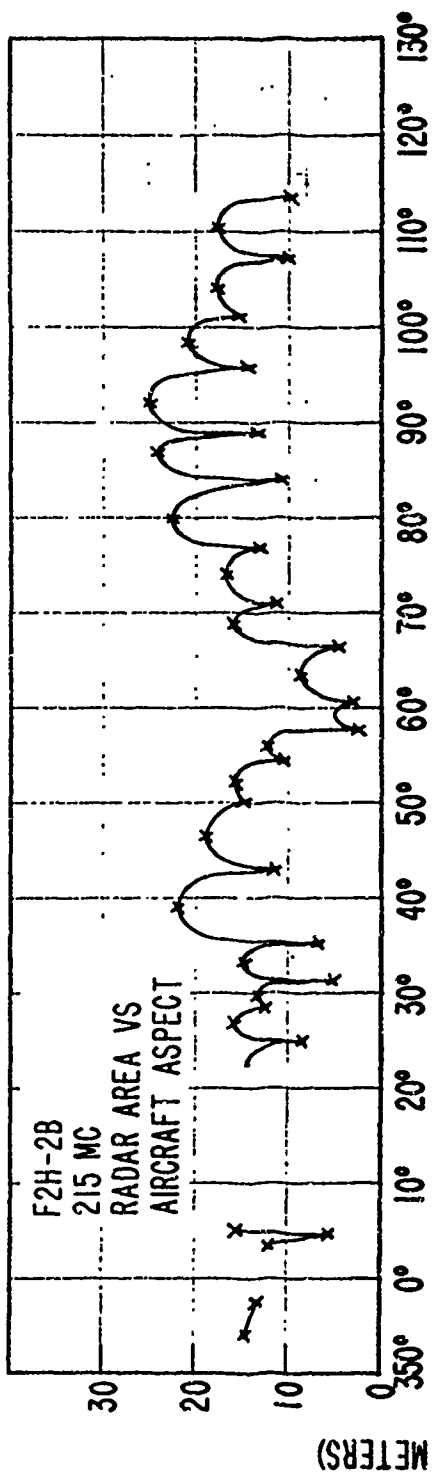

CONFIDENTIAL

Figure 13

CONFIDENTIAL

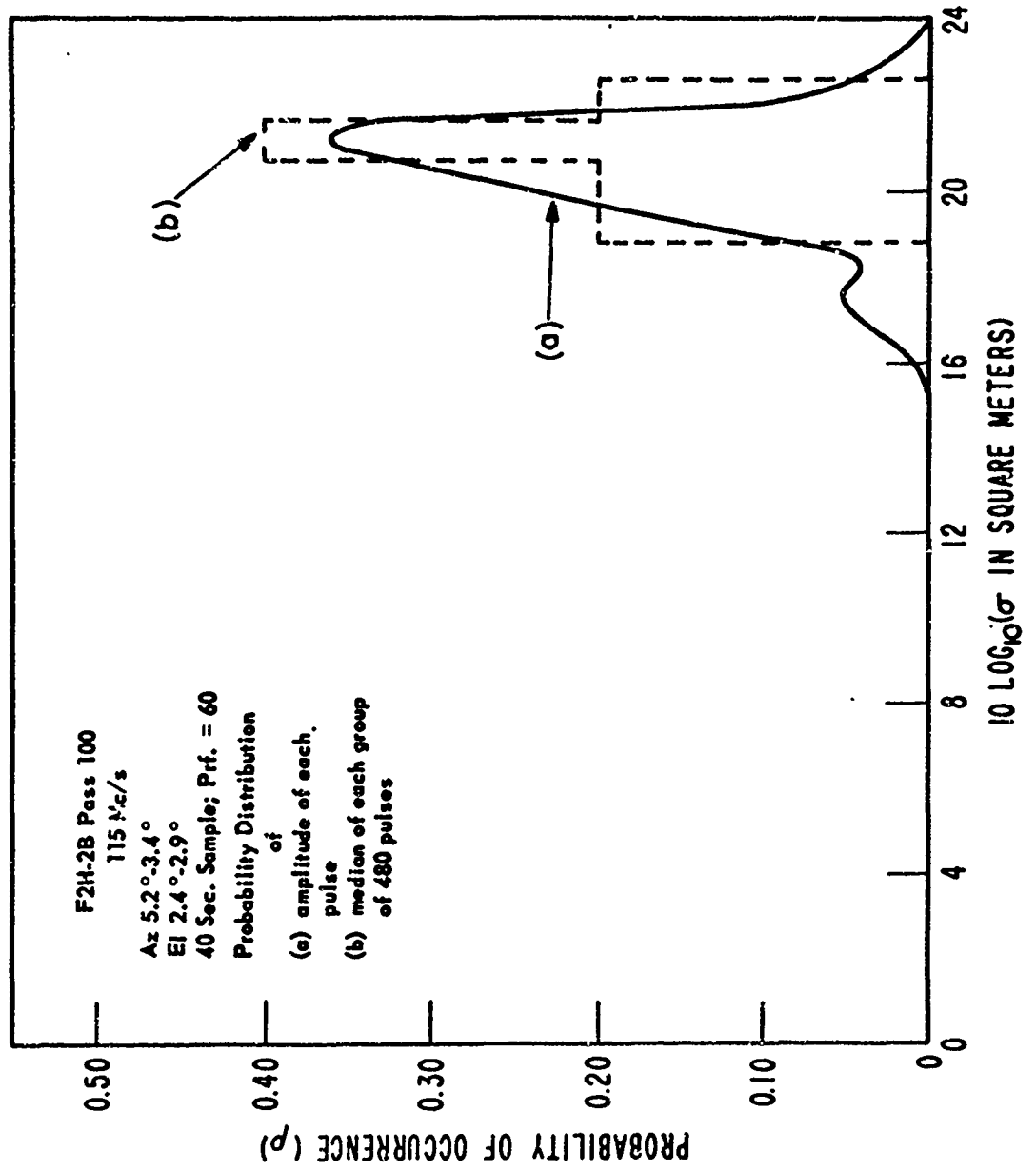

CONFIDENTIAL

Figure 14

CONFIDENTIAL

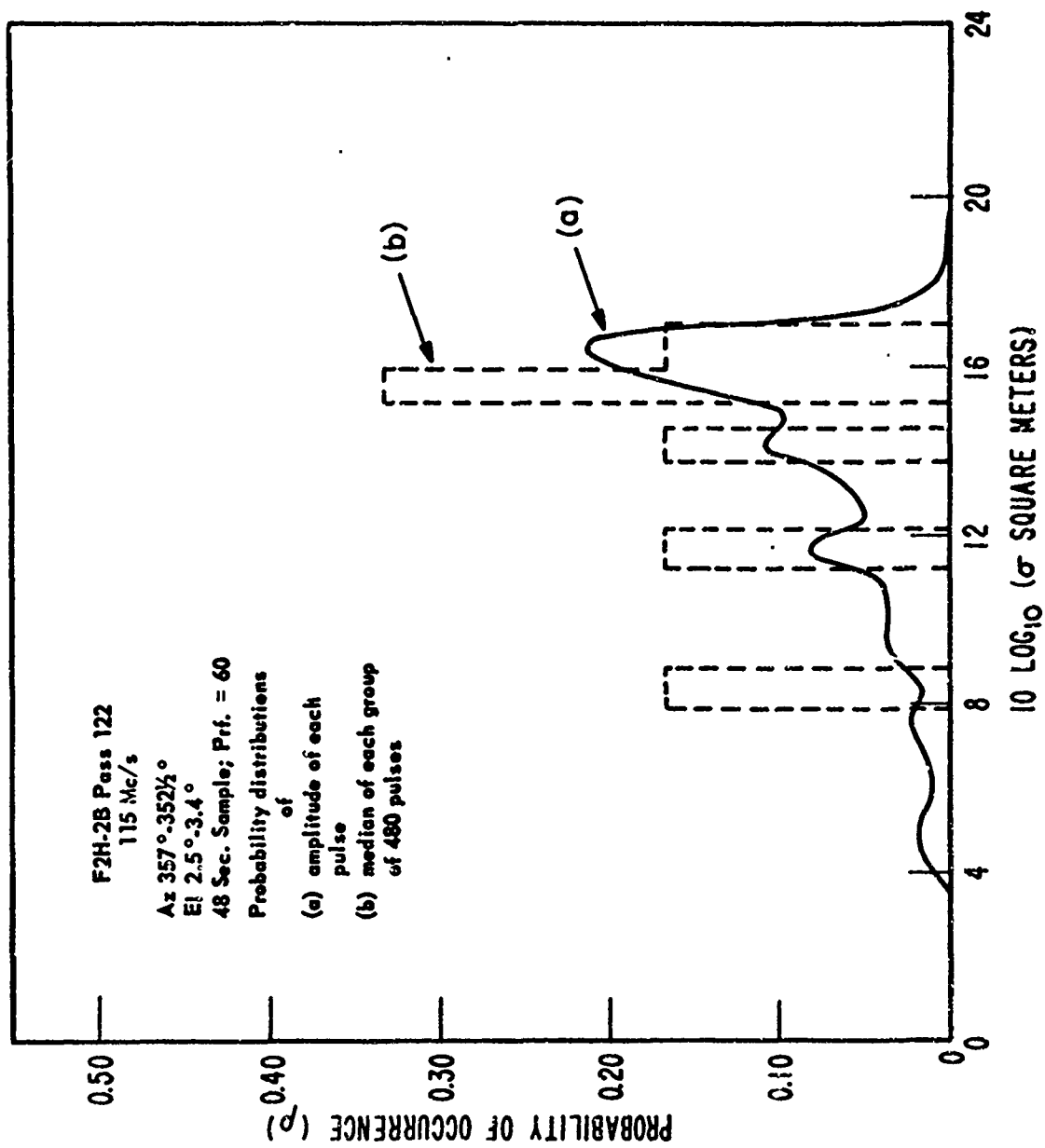

CONFIDENTIAL

Figure 15

CONFIDENTIAL

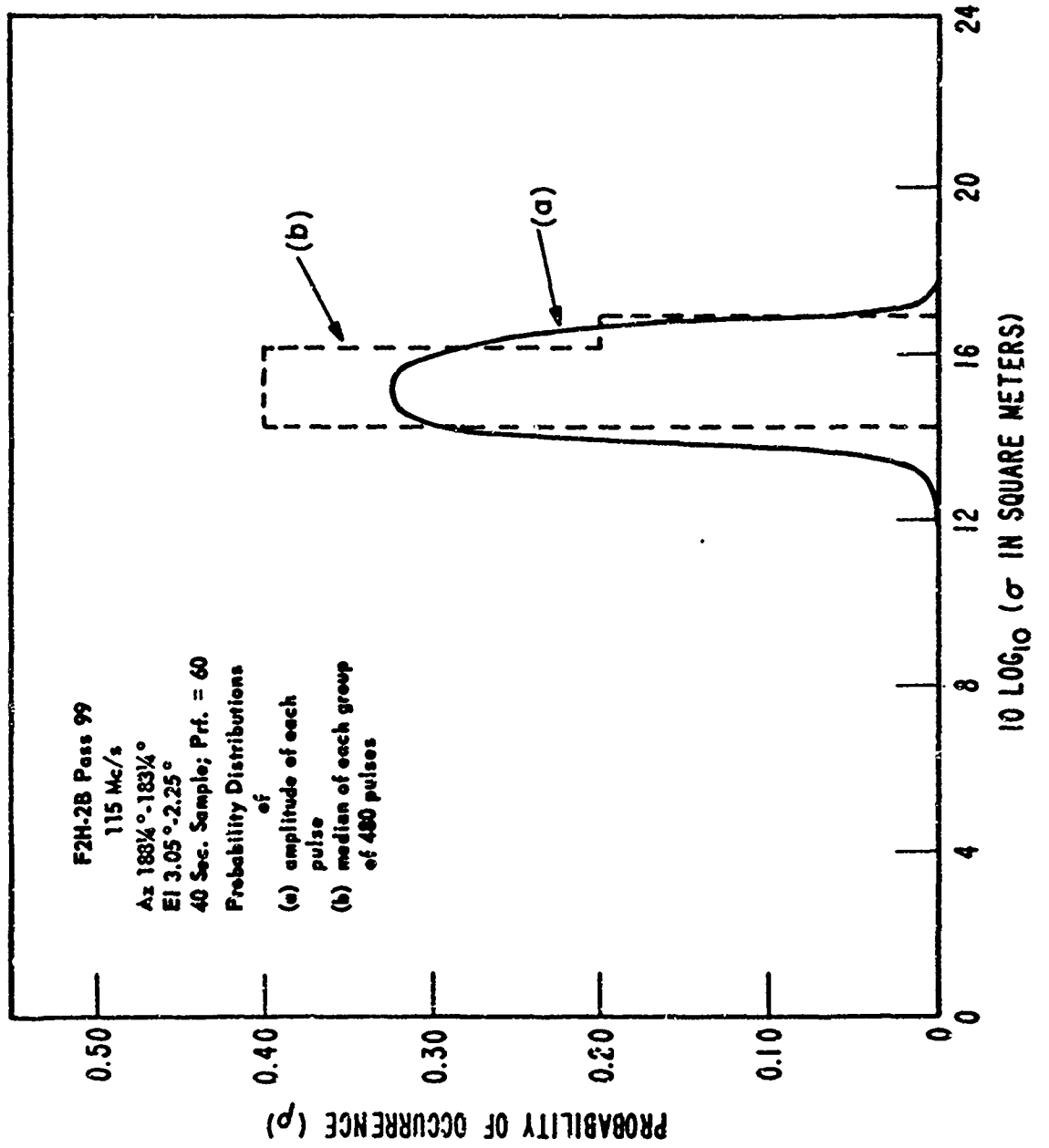

CONFIDENTIAL

Figure 16

CONFIDENTIAL

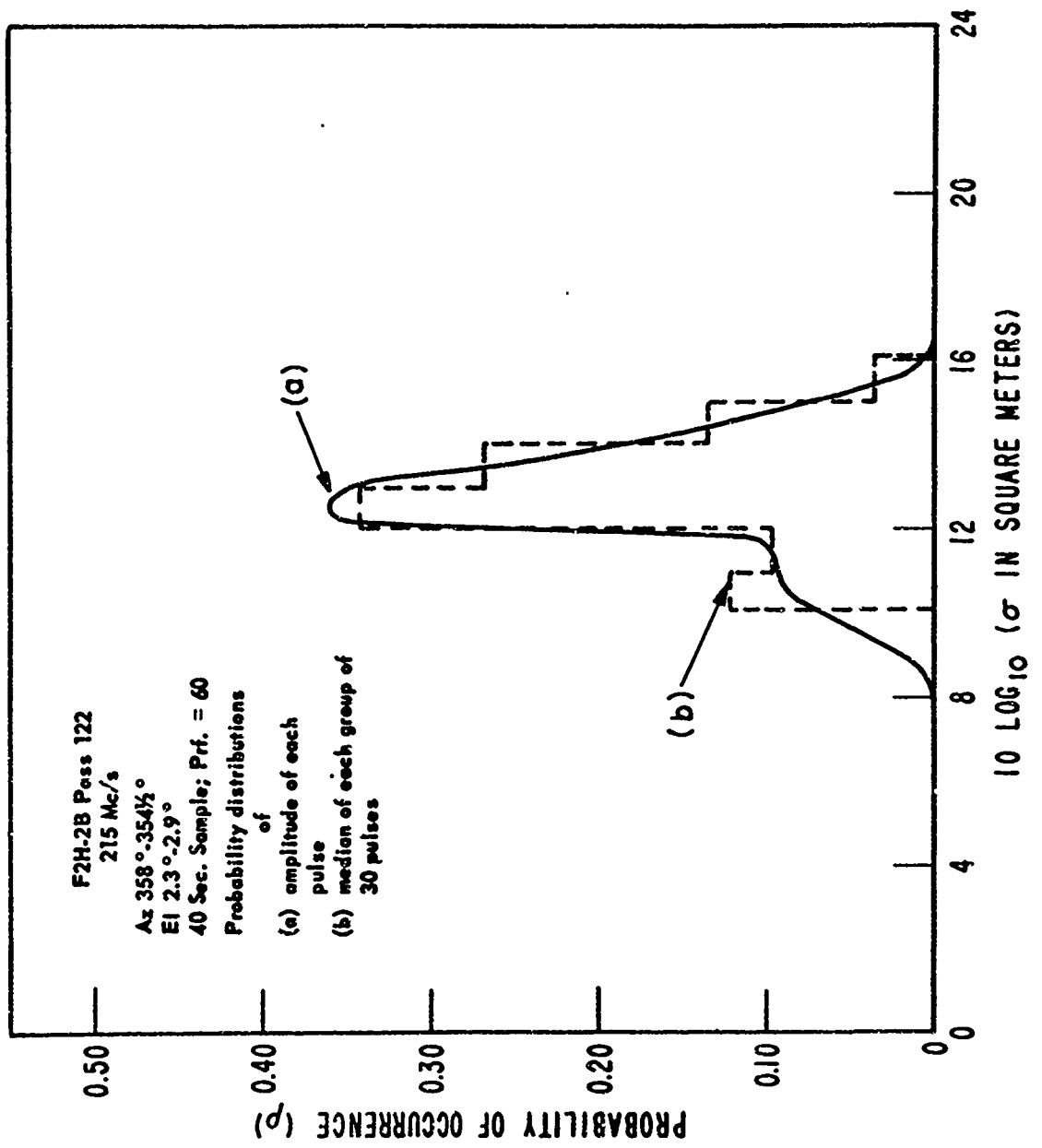

CONFIDENTIAL

Figure 17

CONFIDENTIAL

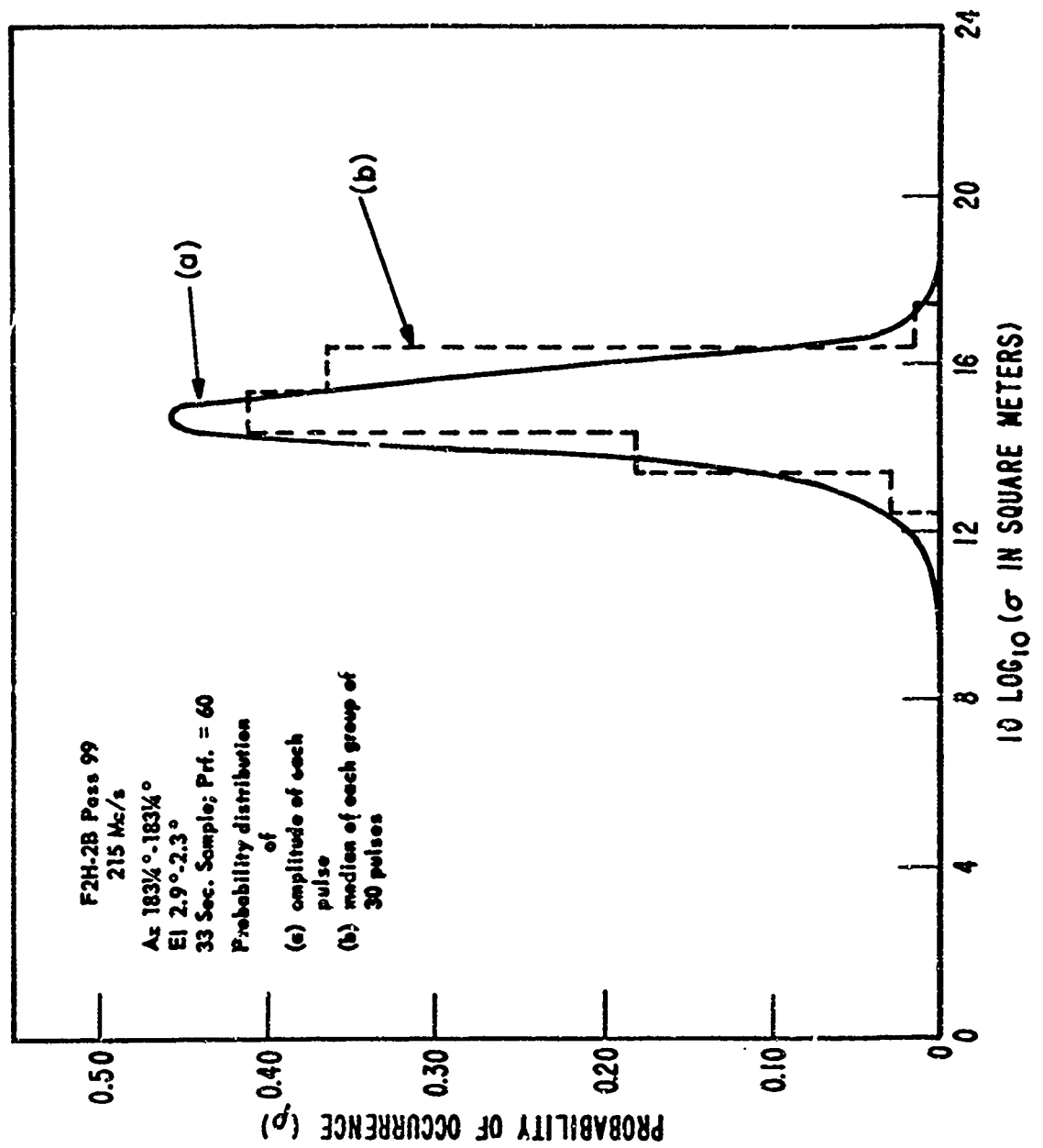

CONFIDENTIAL

Figure 18

CONFIDENTIAL

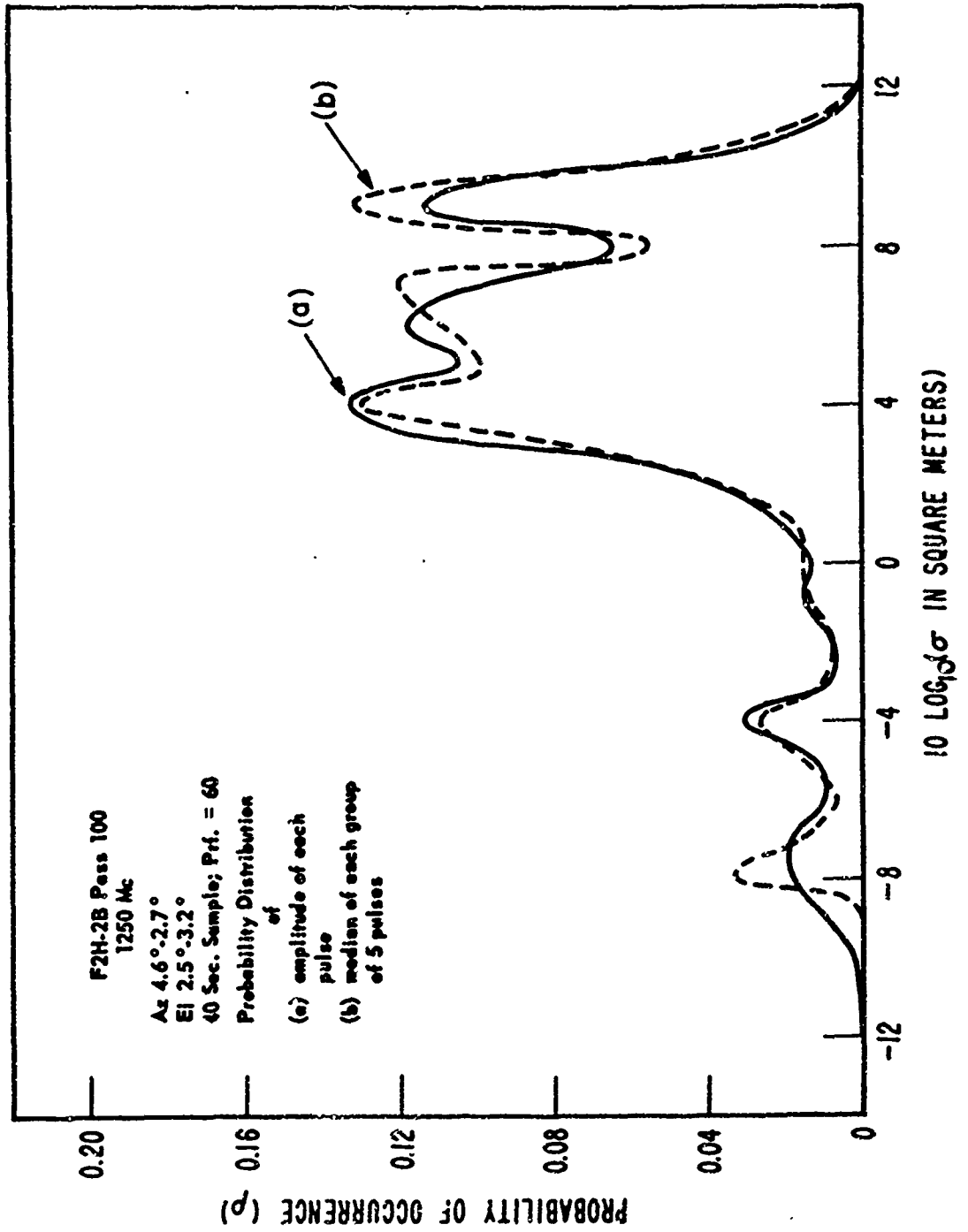

CONFIDENTIAL

Figure 19

CONFIDENTIAL

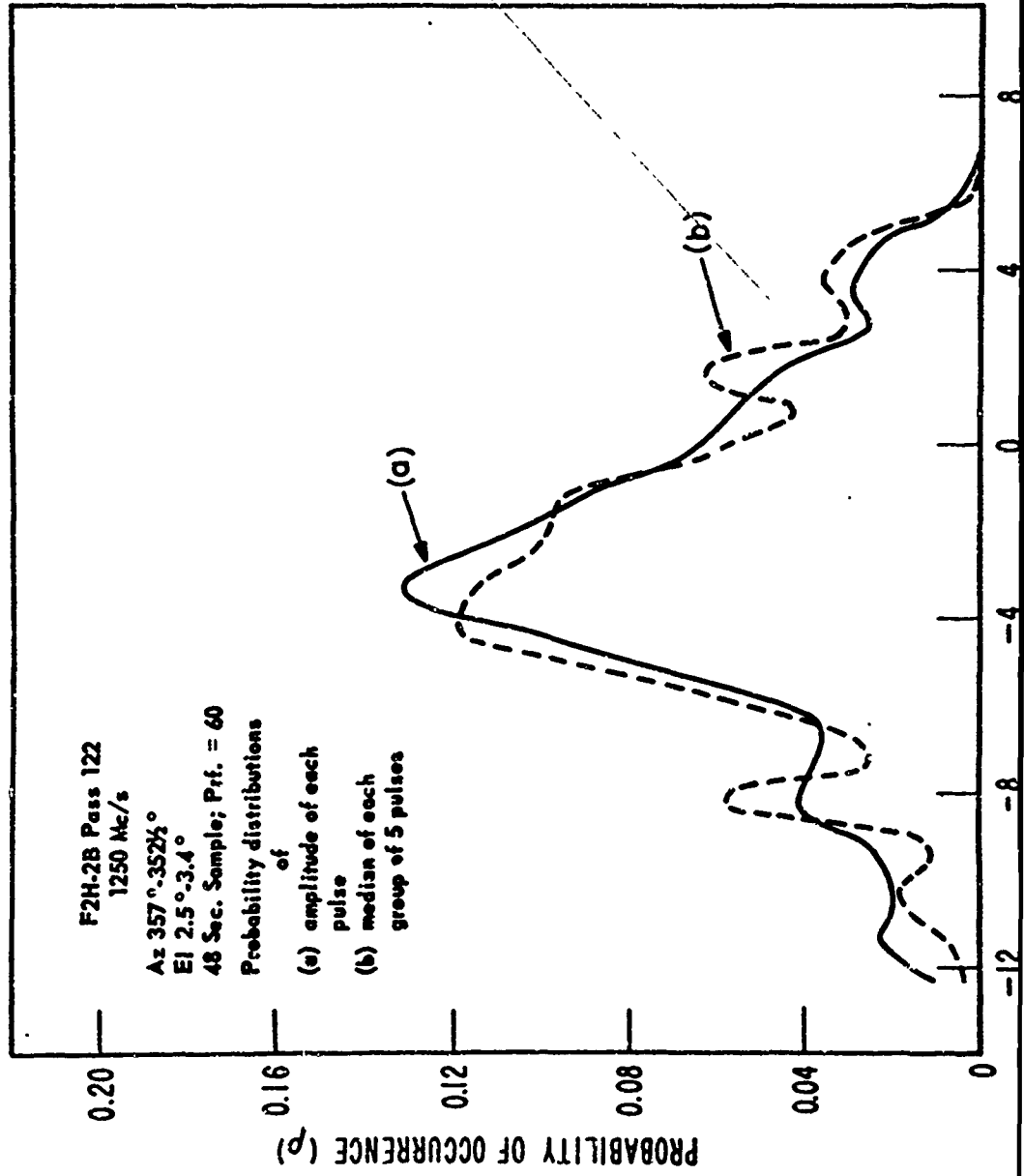

CONFIDENTIAL

CONFIDENTIAL

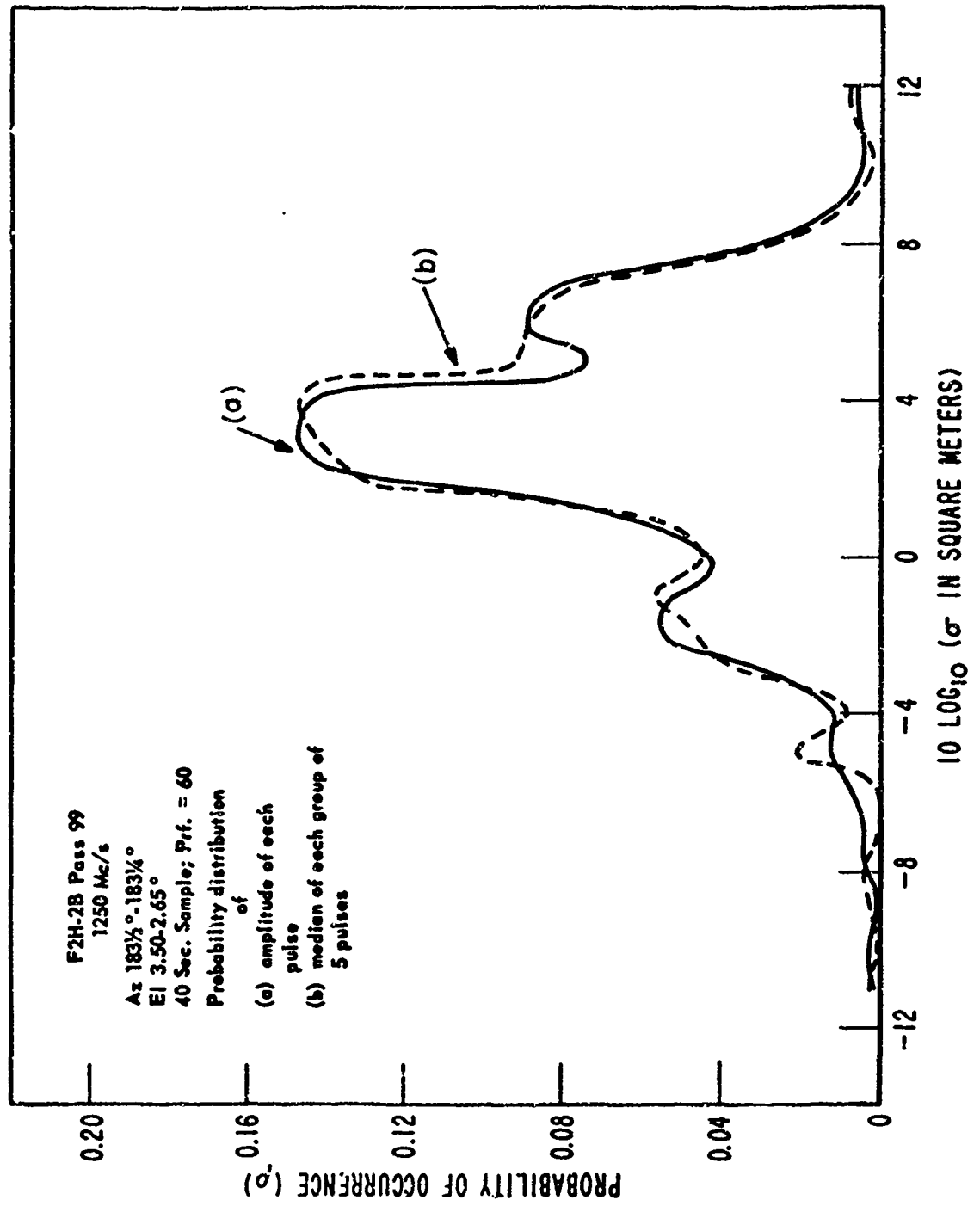

CONFIDENTIAL

Figure 21

CONFIDENTIAL

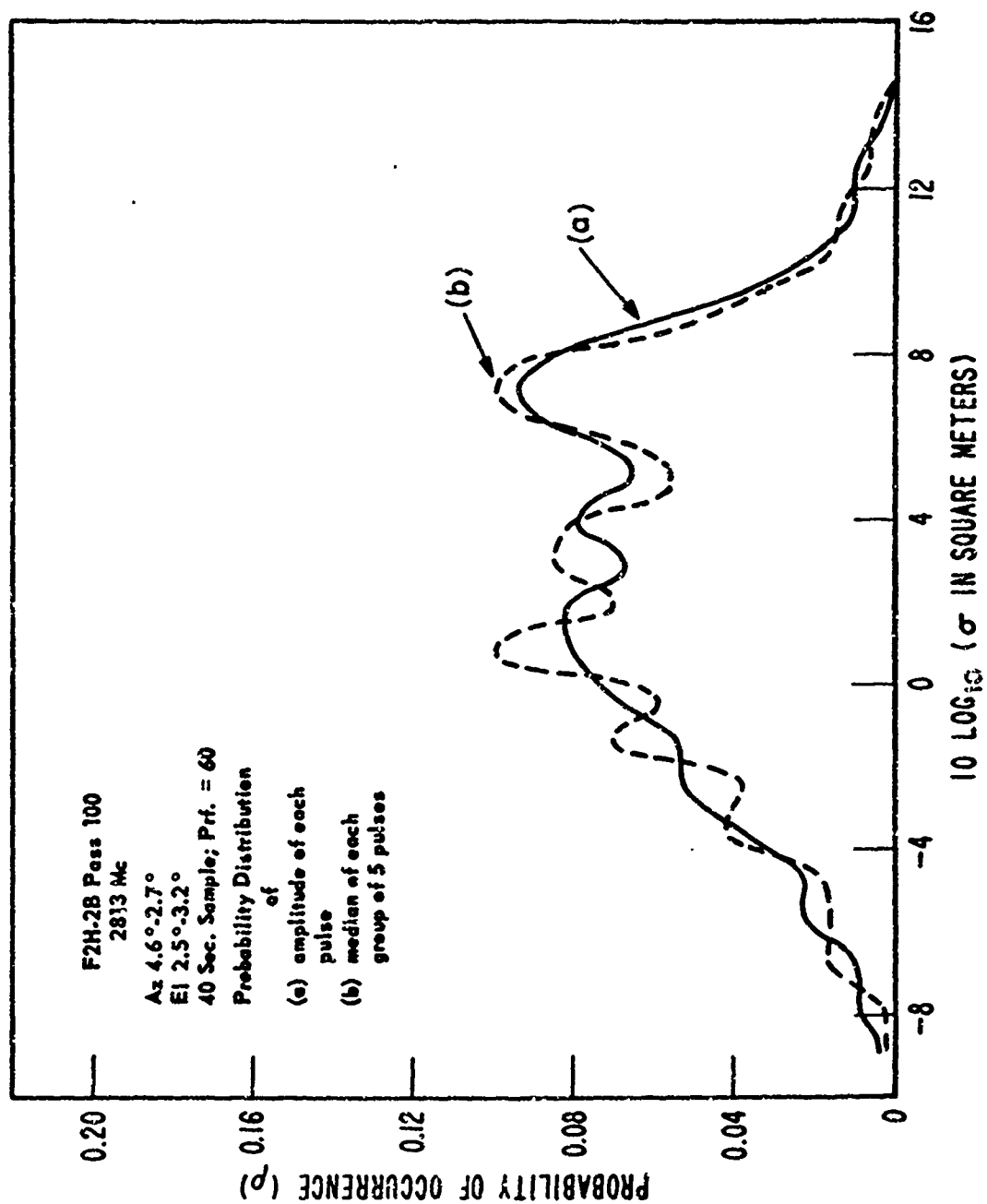

CONFIDENTIAL

Figure 22

CONFIDENTIAL

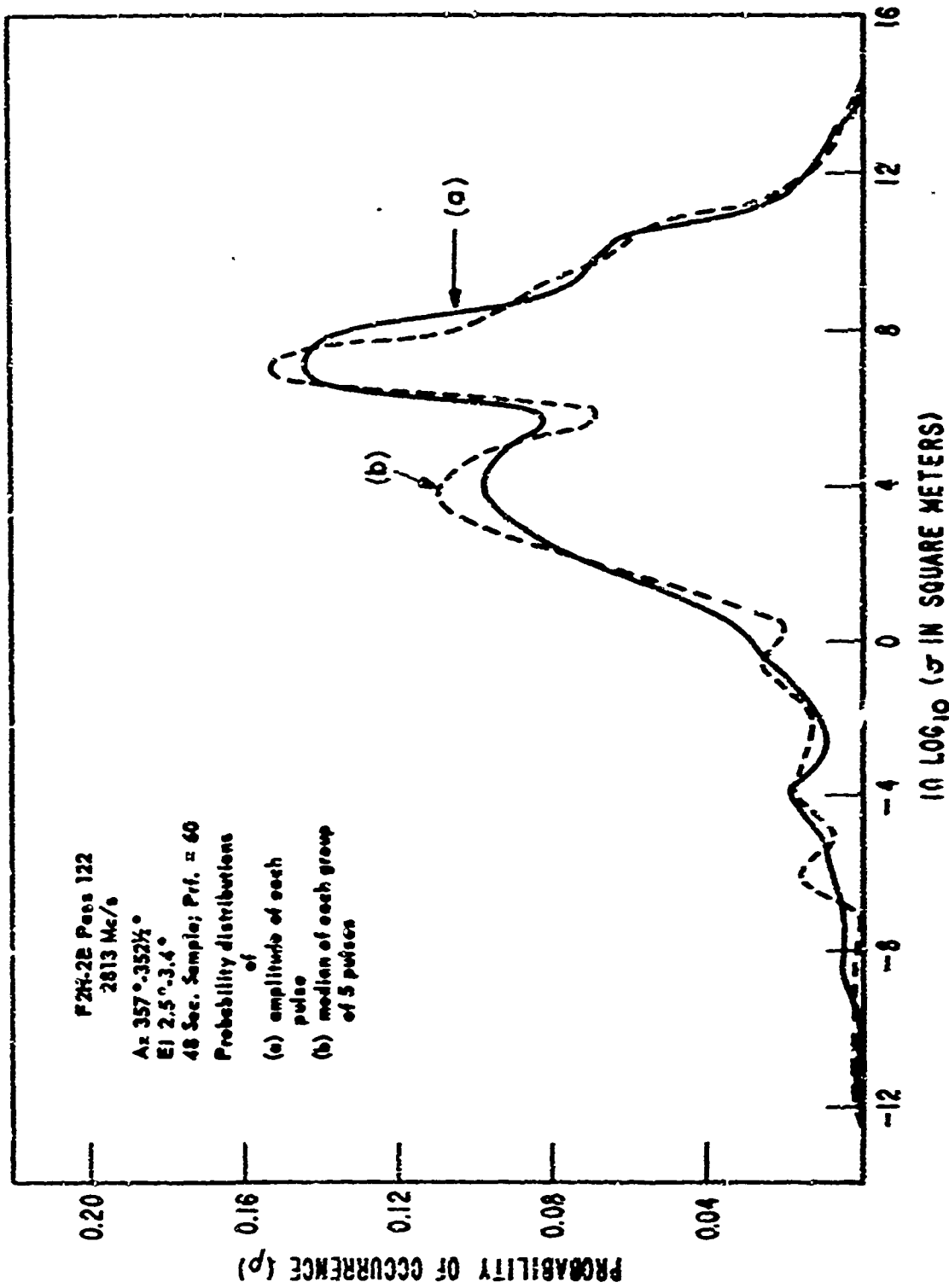

CONFIDENTIAL

Figure 23

CONFIDENTIAL

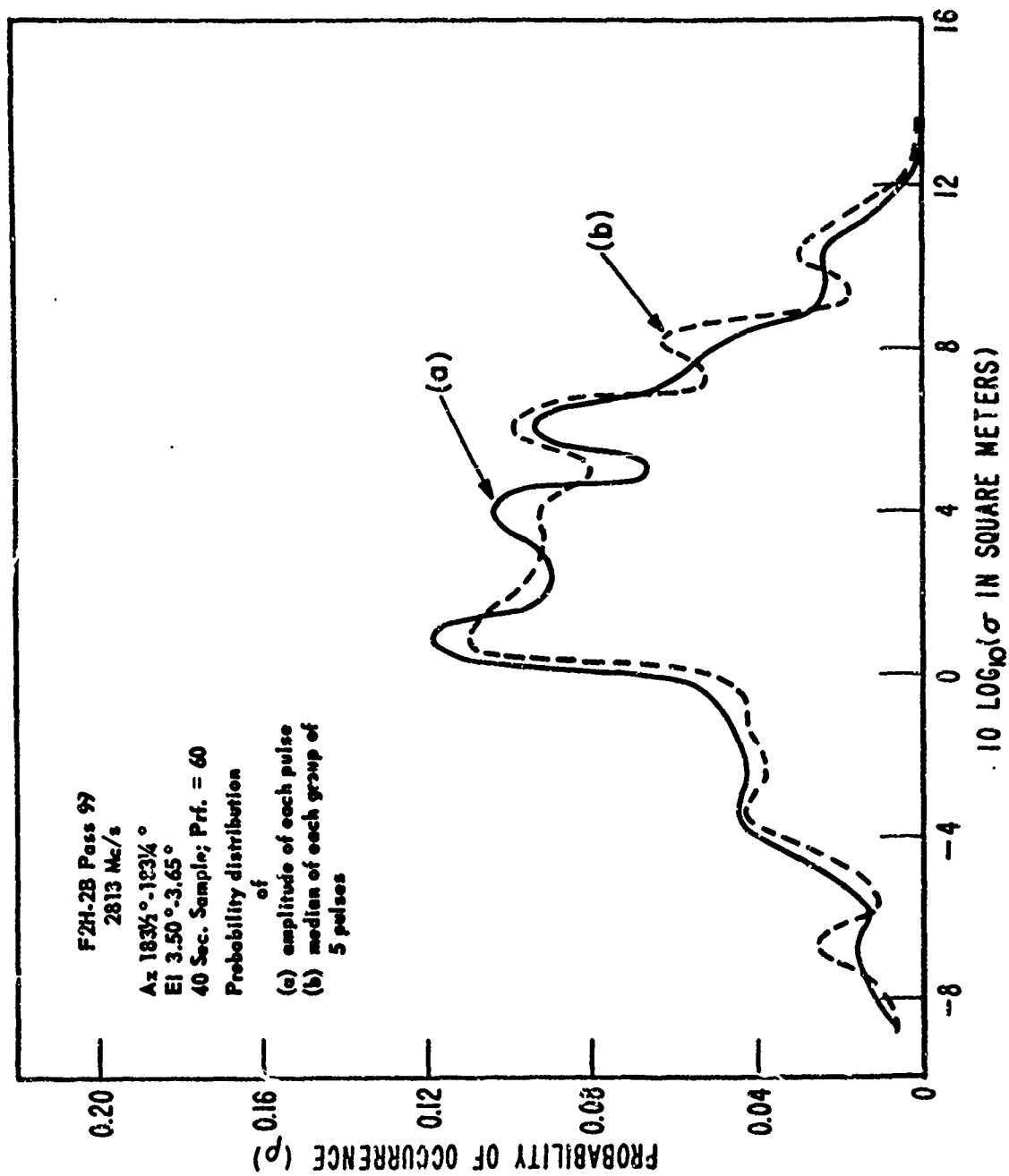

CONFIDENTIAL

Figure 24

CONFIDENTIAL

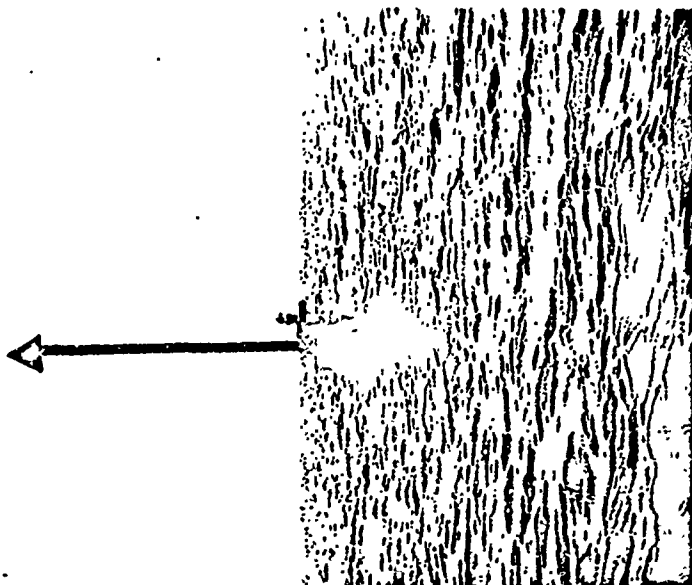

Figure 26

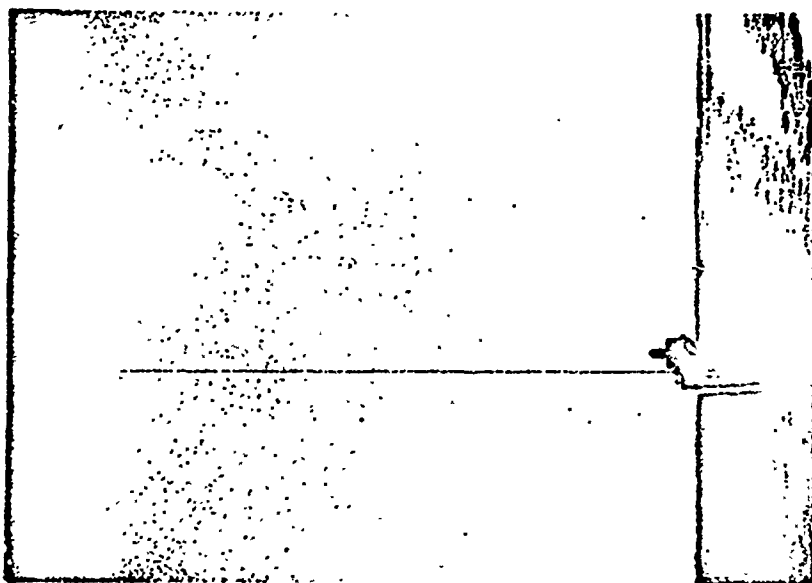
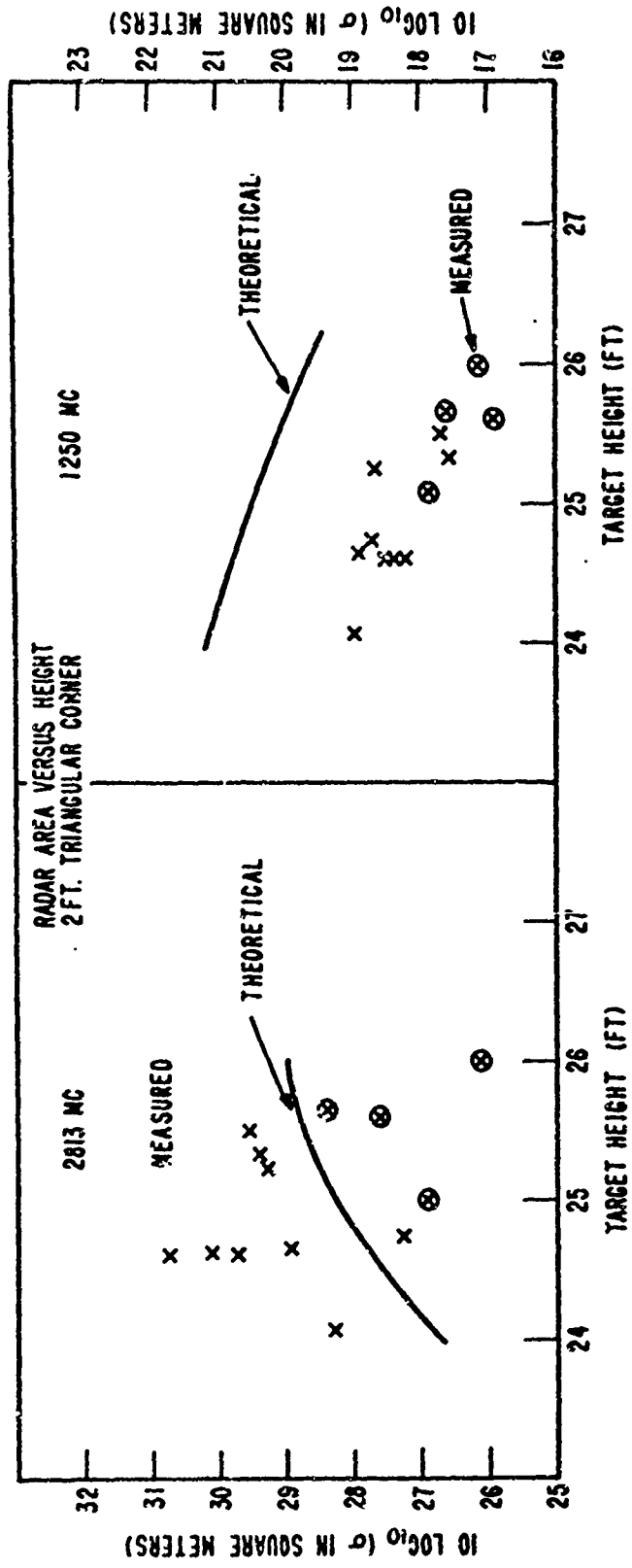

Figure 25

CONFIDENTIAL

CONFIDENTIAL



CONFIDENTIAL

Figure 27

CONFIDENTIAL

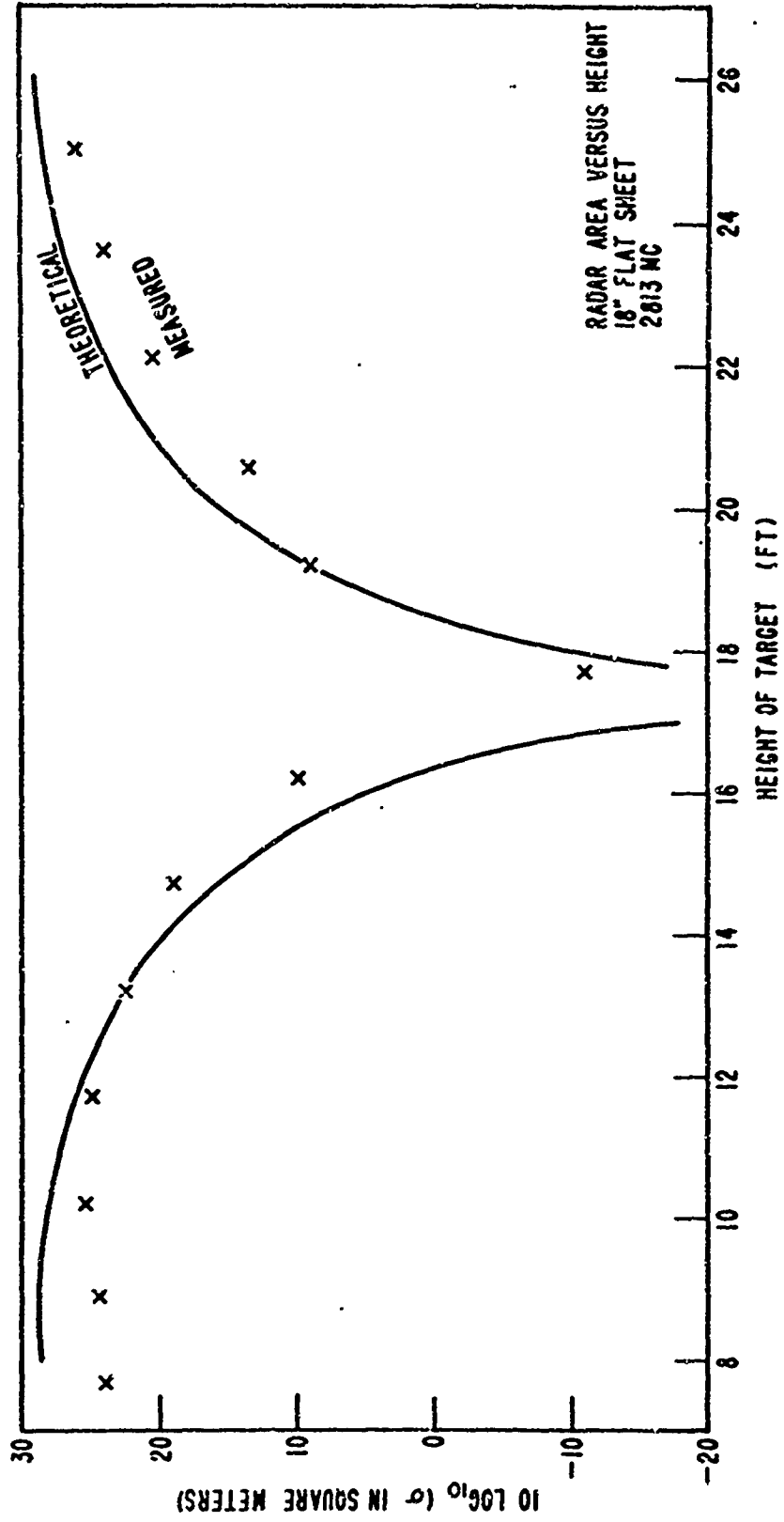

CONFIDENTIAL

Figure 28

CONFIDENTIAL

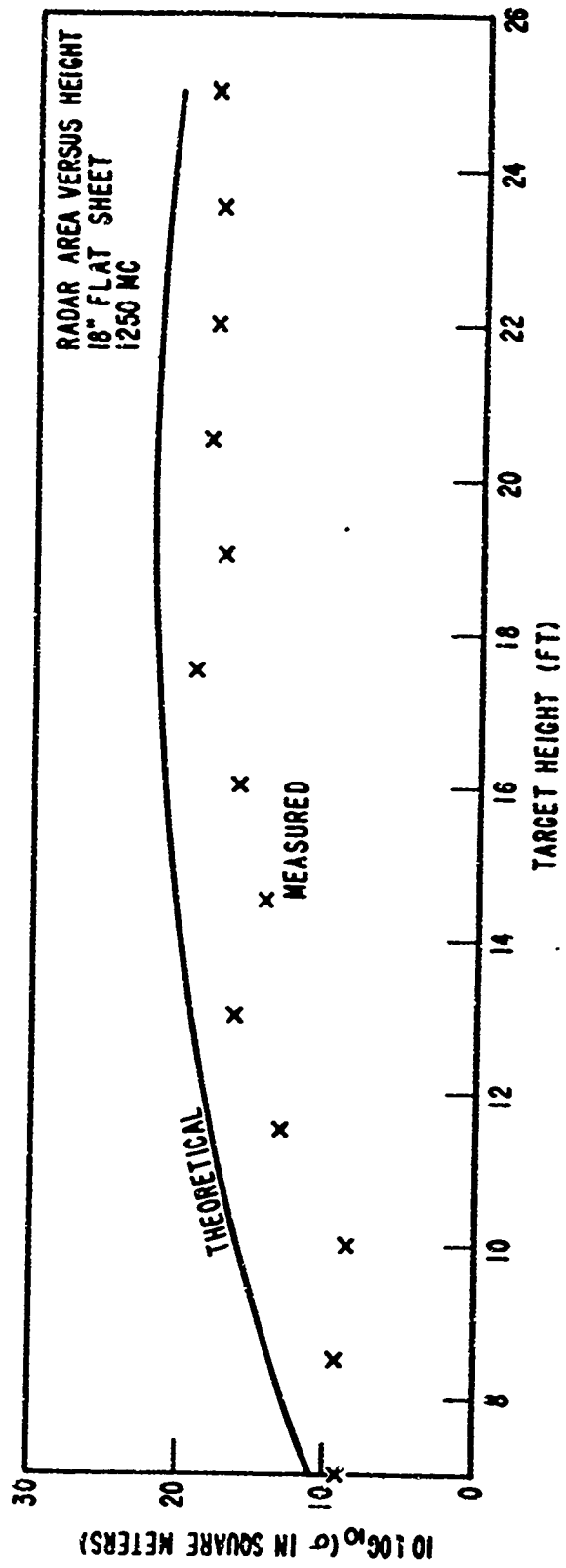

CONFIDENTIAL

Figure 29