

UNCLASSIFIED

<b>AD NUMBER</b>	
<b>AD398357</b>	
<b>CLASSIFICATION CHANGES</b>	
<b>TO:</b>	<b>unclassified</b>
<b>FROM:</b>	<b>confidential</b>
<b>LIMITATION CHANGES</b>	
<b>TO:</b>	<b>Approved for public release, distribution unlimited</b>
<b>FROM:</b>	<b>Distribution authorized to U.S. Gov't. agencies and their contractors; Administrative/Operational Use; 24 JUN 1948. Other requests shall be referred to Chemical Corps Technical Command, Army Chemical Center, MD.</b>
<b>AUTHORITY</b>	
<b>DPG D/A ltr, 24 Aug 1981; DPG D/A ltr, 24 Aug 1981</b>	

THIS PAGE IS UNCLASSIFIED

UNCLASSIFIED

AD 398 357

AUTHORITY:

DPG, DA

1tr, 24 Aug 81



UNCLASSIFIED

# **SECURITY**

---

# **MARKING**

**The classified or limited status of this report applies to each page, unless otherwise marked.**

**Separate page printouts MUST be marked accordingly.**

---

**THIS DOCUMENT CONTAINS INFORMATION AFFECTING THE NATIONAL DEFENSE OF THE UNITED STATES WITHIN THE MEANING OF THE ESPIONAGE LAWS, TITLE 18, U.S.C., SECTIONS 793 AND 794. THE TRANSMISSION OR THE REVELATION OF ITS CONTENTS IN ANY MANNER TO AN UNAUTHORIZED PERSON IS PROHIBITED BY LAW.**

**NOTICE: When government or other drawings, specifications or other data are used for any purpose other than in connection with a definitely related government procurement operation, the U. S. Government thereby incurs no responsibility, nor any obligation whatsoever; and the fact that the Government may have formulated, furnished, or in any way supplied the said drawings, specifications, or other data is not to be regarded by implication or otherwise as in any manner licensing the holder or any other person or corporation, or conveying any rights or permission to manufacture, use or sell any patented invention that may in any way be related thereto.**

UNANNOUNCED  
JUL 12 1948

CONFIDENTIAL

TCR  
Project 4-0

①  
72

57993

AD 398357

AD 398357

PRELIMINARY INVESTIGATION OF FIRE BOMBS FOR  
HIGH-PERFORMANCE FIGHTER AIRCRAFT

By

D. G. Shure

R. B. Wheeler

N. H. Malahoff

DDC  
FEB 27 1968  
A

AD No. \_\_\_\_\_  
DDC FILE COPY

FILE COPY  
Science and Technology Project  
Library of Congress  
DO NOT RETURN

LIBRARY OF CONGRESS  
SCIENCE & TECHNOLOGY PROJECT  
TECHNICAL INFORMATION SECTION

JUL 27 1948

CHEMICAL CORPS TECHNICAL COMMAND  
Army Chemical Center, Maryland

24 June 1948

This document contains information affecting the National  
Defense of the United States within the meaning of the  
Espionage Laws, Title 18, U. S. C., Section 793 and  
794. Its transmission or the revelation of its contents  
in any manner to an unauthorized person is prohibited  
by law.

Copy Note

CONFIDENTIAL

TECHNICAL LIBRARY  
EDGEWOOD ARSENAL

JUL 19 1948

CONFIDENTIAL

CHEMICAL CORPS TECHNICAL COMMAND  
ARMY CHEMICAL CENTER, MARYLAND

TCR-4  
16 CCTC-  
Project 4-04-16-06 (B 11.9-5)

6 PRELIMINARY INVESTIGATION OF FIRE BOMBS FOR  
HIGH-PERFORMANCE FIGHTER AIRCRAFT [U],

Submitted by:

*D. G. Shure*  
D. G. Shure

\*Author

↑

10 *R. B. Wheeler*  
R. B. Wheeler

*N. H. Malakoff*  
N. H. Malakoff

Recommending approval:

*R. L. Ortynsky*  
R. L. Ortynsky  
Chief, Air Force Munitions Branch

APPROVED:

*F. B. Mitman, Jr.*  
F. B. MITMAN, Jr.  
Major, CmlC  
Chief, Munitions Division

Notebook: 2789

Experimental Works:

Started: 1 July 1947  
Completed: Continuing

Typed: 11 24 Jun 1948  
eh

12 24 p.

DOWNGRADED AT 10 YEAR  
INTERVALS: NO  
DECLASSIF.

Control no.  
5018-4

CONFIDENTIAL

*mt*

(080 300)

*ef*

CONFIDENTIAL

ABSTRACT

Object.

The object of project 4-04-16-06 (B 11.9-5) is to develop a fire bomb for high-performance fighter aircraft.

The object of the work described in this report was to conduct a preliminary investigation and to evaluate the end item in the design and model stage prior to full-scale engineering tests.

Results.

The literature search comprised a survey of the work done on fire bombs, including that on fillings of various grades of thickened gasoline, altitude of release, density of fire, ground coverage, and functioning on different types of terrain.

Six drop tests were conducted with unstabilized containers (modified smoke tanks M10; photo. 14355, appendix A), which were adapted to receive igniters M15 mounted externally at the nose and the tail. Satisfactory functioning of the igniters in these positions permitted preparation of a design in which the igniters could be placed within fairings at the nose and tail giving the tank uninterrupted streamlined shape.

A number of knockdown fuel tanks for the P-80 airplane were procured for use as the casing of the firebomb and a model fire bomb, designated the E47, was prepared (photo. 14596) for installation tests on the available high-performance airplanes. Installation drawings were prepared (dwgs. C18-64-770, C18-64-836, C18-64-768, C18-64-837, C18-64-769, appendix B) to determine the possibility of fitting all airplanes with the same model fire bomb.

Flight tests of the model fire bomb mounted on a P-47 airplane were conducted at velocities up to 360 m.p.h. to determine the stability of the nose and tail fairings (photo. 14619, appendix A).

Conclusions.

1. A fire bomb design based on the modification of the 165-gal. knockdown range-extension tank for the P-80 airplane, to incorporate external igniters inclosed within fairings at the nose and tail, will be satisfactory for the P-80, P-82, and P-86 airplanes, and possibly for the P-90 and subsequent fighter aircraft, and will be available for use in the shortest period of time.

2. The concurrent development of a fire bomb having a capacity of approximately 100 gal., a maximum diameter of 24 in., a fineness ratio of five to one, and identical in all other respects to the fire bomb mentioned in

CONFIDENTIAL

CONFIDENTIAL

conclusion 1, for use with the P-80, P-82, P-84, P-85, P-86, and subsequent fighter aircraft, is necessary. This bomb will lead to the obsolescence of the bomb mentioned in conclusion 1.

Recommendations.

None, since work on the development of a fire bomb for high-performance fighter aircraft is continuing.

CONFIDENTIAL

CONFIDENTIAL

TABLE OF CONTENTS

	Page
I. INTRODUCTION.....	1
A. Object.....	1
B. Authority.....	1
II. HISTORICAL.....	1
A. General.....	1
B. Location of Igniters.....	1
C. Size of Fire Bomb.....	2
D. Temperature Effects.....	2
III. THEORETICAL.....	2
IV. EXPERIMENTAL.....	4
A. Procedure.....	4
1. Procurement of Tanks, Drawings, and Reports.....	4
2. Installation.....	4
3. Location of Igniters.....	5
4. Flight Tests of Model.....	5
B. Results.....	5
1. Procurement of Tanks, Drawings, and Reports.....	5
2. Installation.....	6
3. Location of Igniters.....	6
4. Flight Tests of Model.....	7
V. DISCUSSION.....	7
VI. CONCLUSIONS.....	10
VII. RECOMMENDATIONS.....	10
VIII. BIBLIOGRAPHY.....	10
APPENDIXES	
Appendix A, Photos, 14355, 14596, 14594, 14619, 14639 14640, and 14638.....	12
Appendix B, Dwg. C18-64-770, C18-64-836, C18-64-768, C18-64-837, and C18-64-769.....	20

CONFIDENTIAL

CONFIDENTIAL

PRELIMINARY INVESTIGATION OF FIRE BOMBS FOR  
HIGH-PERFORMANCE FIGHTER AIRCRAFT

I. INTRODUCTION.

A. Object.

The object of project 4-04-16-06 (B 11.9-5) is to develop a fire bomb for high-performance fighter aircraft.

The object of the work described in this report was to conduct a preliminary investigation and to evaluate the end item in the design and model stage prior to full-scale engineering tests.

B. Authority.

Authority for this work was the 1948 project program, Project 4-04-16-06 (B 11.9-5), Fire Bomb for High-Performance Fighter Aircraft.

II. HISTORICAL.

A. General.

The use of a large incendiary munition for close tactical support of ground troops and for the destruction of materiel was conceived in the active theaters of operation during World War II. It is reported that jettisonable fuel tanks of fighter aircraft, released over targets of opportunity and then ignited by incendiary or tracer ammunition fired by accompanying aircraft, produced remarkably effective results. This use led to the development of the thickened-gasoline-filled fuel tank, which was used extensively as a fire bomb in both the European and Pacific theaters. The original work on this improved munition was done by the Army Air Forces Proving Ground Command at Eglin Field, Florida (1,2,3, and 4).

The tests conducted by the AAF indicated that jettisonable fuel tanks filled with napalm-thickened fuel and fitted with incendiary hand grenades or incendiary bombs produced a fire of sufficient magnitude and intensity to insure considerable incendiary effect. The thickened fuel reduced "splash," thus concentrating the fire.

The fire bomb proved very successful during the recent war and "is regarded as responsible for one of the break-throughs in France, the surrender of St. Malo, and the death of von Kluge." (6, note 5).

B. Location of Igniters.

Although the fire bomb possessed a considerable degree of effectiveness, it was desirable that improvements in ignition devices be effected. It was necessary to determine the functioning efficiency of

CONFIDENTIAL

CONFIDENTIAL

externally attached igniters as opposed to those mounted internally or to a combination of both, that is, one internal and one external igniter. Exhaustive tests were conducted and it was recommended (6) that the fire bomb should be fitted with two external-type igniters.

C. Size of Fire Bomb.

Various sizes of jettisonable fuel tanks and bombs were tested to determine the optimum size for a fire bomb. The 165-gal. tank was found to be the most effective. When compared to the U.S. Navy bomb Mark 66, Mod. O. (1,000-lb.) (7), the U.S. Navy practice bomb Mark 67 (2,000-lb.) (8), and the 58-gal. aircraft jettisonable fuel tank (9), the 165-gal. jettisonable fuel tank proved three to four times as effective. Comparison was based on the effective coverage, fireball effect, altitude of release, and ignition.

D. Temperature Effects.

The effect of extreme temperatures on the functioning of the fire bomb has been studied only partially. Since the fire bomb was subjected to miscellaneous tests at temperatures up to approximately 100°F. only, no specific study has been made of its functioning at extreme high temperatures. However, a project was established to determine functioning of the bomb under extreme cold weather conditions. Under this project, a test was conducted by the AAFPGC (10) in Alaska at temperatures ranging between -44°F. and -70°F. The conclusions were based on the testing of 75 different gels prepared under varying conditions. The coverage and fireball effect were considered by the test personnel to be slightly better than those obtained in warmer climates. It was proved that gel can be mixed in temperatures as low as -44°F., and it was concluded that extreme cold weather has no effect on the functioning of the fire bomb.

III. THEORETICAL.

The military requirement for a fire bomb for high-performance fighter airplanes was established and the military characteristics were approved on 26 June 1947 (item 1750, CCTC Minutes).

The military characteristics for the fire bomb are as follows:

1. Total weight of the filled fire bomb should not exceed wing load allowance for bomb rack. The filling for this munition should be of the field-mixed, gelled gasoline type.
2. As many as practical of the features of the knockdown fuel tanks now being used or being developed by the Army Air Forces should be incorporated in the fire bomb.
3. The fire bomb should be suitable for carriage without modification of installation features on the wings of fighter aircraft including the P-80, P-84, P-86, P-88, P-90, and subsequent fighters.

CONFIDENTIAL

CONFIDENTIAL

4. The fire bomb should have optimum streamlined characteristics at least comparable to the 165-gal. droppable fuel tank designed for the P-80 airplane.
5. The fire bomb should not fail in any part when subjected to the accelerations currently specified by Army Air Forces.
6. The fire bomb should have an overall functioning percentage of 95.
7. The fire bomb should be safely jettisonable when full or empty and in level flight at airspeeds up to 600 knots.
8. The fire bomb should, if practicable, be suitable for at least six months' storage when filled with any of the authorized agents.
9. The tank of the fire bomb should be adaptable for nested shipments.
10. The tank of this bomb should be designed so that it can be widely employed as a jettisonable range-extension tank.

The approved military characteristics were revised 4 March 1948 (item 1827, CCTC Minutes), as follows:

1. Par. 10 (The tank of this bomb should be designed so that it can be widely employed as a jettisonable range extension tank) was deleted.
2. Par. 4 was changed to read: "The fire bomb should have optimum streamlined characteristics consistent with operational and structural limitations."

The 165-gal. knockdown range-extension tank for the F-80 airplane, existing and available for this development, will presumably meet the military characteristics listed in pars. 1, 2, 4, 5, 7, 8, 9, and 10.

Installation drawings and installation tests are necessary to determine compliance with par. 3. Also, since each airplane is mocked-up prior to manufacture and mock-up bombs are installed on the racks, a fire bomb of approximately the same configuration as the existing fire bomb (165-gal. range-extension tank) should fit.

For compliance with the military characteristic listed in par. 6, two external igniters have been recommended (6). Preliminary tests are necessary.

The action approved by CCTC item 1827 does not necessarily change the foregoing analysis, but eliminates only those portions of the characteristics covering the use of the fire bomb as a range-extension tank. Optimum streamlined characteristics will vary from airplane to airplane and must be determined by extensive wind tunnel studies. An optimum streamlined fire bomb for all the fighter aircraft enumerated will obviously be a compromise and will be the result of investigation to comply with par. 3 of the military characteristics.

CONFIDENTIAL

CONFIDENTIAL

IV. EXPERIMENTAL.

A. Procedure.

1. Procurement of Tanks, Drawings, and Reports.

An inquiry as to the use of the P-80 range-extension tank was made in July 1946 in connection with the development of an all-purpose chemical tank (project B 3.1-16, canceled), and it was found that the range-extension tanks would be available after January 1947. Circulation of the proposed military characteristics for the fire bomb resulted in a renewal of negotiations, in April 1947, to secure a number of the P-80 range-extension tanks for use. Subsequently, 52 tanks were ordered.

A chronological listing of requests from the U.S. Air Force for data on the airplanes and on range-extension tanks is as follows;

July 1946	Request for data on P-80, P-84, and P-86 airplanes. Request for six P-80 range-extension tanks.
October 1946	Request for drawings of P-80 range-extension tank.
April 1947	Request for two P-80 range-extension tanks. Request for 52 P-80 range-extension tanks.
September 1947	Request for data on installation of the P-80 range-extension tank on P-80, P-82, P-84, P-86, P-88, and P-90 aircraft. Request for data on proof-testing of the P-80 range-extension tank.
November 1947	Request for die drawings of the P-80 range-extension tank. Request for detail drawings of the wing, bomb shackle, and sway brace installation of the P-82, P-84, P-86, P-88, and P-90 aircraft. Request for data on other range-extension tanks.

2. Installation.

Arrangements were made with the Air Materiel Command, Wright Field, to conduct installation tests of fire bomb E47 (modified 165-gal. range-extension tank) on the P-80, P-82, and P-84 airplanes. The fire bomb was flown to Wright Field in the bomb bay of a B-25 airplane in March 1948 for these tests.

Considerable difficulty was encountered in installing the fire bomb in the bomb bay of the B-25 for this trip. It was necessary to remove all fairings and to rope the bomb in a diagonal position.

It appeared from the installation drawings that it might be necessary to lengthen the suspension lugs on the bomb to facilitate mounting on the P-82 airplane, due to interference with the bomb rack pylons. Two 2-in. and several 1/4-in. spacers were made so the bomb could be mounted under any conditions.

CONFIDENTIAL

CONFIDENTIAL

3. Location of Igniters.

After a review of available literature on the fire bomb, and of design characteristics, it was tentatively decided to place two external igniters, inclosed within fairings, at the nose and the tail of the fire bomb. Six M10 airplane smoke tanks were modified (photo. 14355, appendix A) to receive standard M15 igniters at the nose and tail. The inert containers were dropped from a P-47 airplane at 173 knots (200 m.p.h.) indicated airspeed from an altitude of 100 ft. to determine fuze functioning with respect to location. The arming vanes of the igniters were also modified to present the ball face 30° to the perpendicular.

4. Flight Tests of 1,000-lb. Fire Bomb E47.

To determine the flight stability of the model fire bomb E47 with fairings attached (photo. 14596, appendix A), two models were modified with a U-shaped wavy brace and mounted on a P-47N airplane (photo. 14594, appendix A). Flight tests were conducted with the empty fire bombs at velocities up to 252 knots (360 m.p.h.), with the airplane taking evasive action to simulate flight conditions in combat. Motion pictures of the nose and tail fairings were taken in flight (photo. 14619, appendix A), using the M1C photo. tank and two AN-M6 gun cameras.

B. Results.

1. Procurement of Tank, Drawings, and Reports.

Fifty-two range-extension tanks were received for use in fabricating a preliminary model of the fire bomb and in future engineering tests. The tanks were manufactured by Curtis-Wright on contract, in accordance with Weber Showcase Company dwg. W-165001.

Drawings of the range-extension tank (Weber Showcase Co. dwg. W-165001) were received in February 1948. Tentative sketches were prepared and detail drawings on which to prepare a model for installation tests were begun in September 1947. A model of the fire bomb, designated the E47, was completed in February 1948.

Drawings of the P-80 airplane were received in August 1946, drawings of the P-84 and P-88 airplanes were obtained on a visit to the Air Materiel Command in February 1948, and drawings of the P-82 and P-86 airplanes were received in March 1948. No drawings on the P-90 or subsequent fighters are available. After receipt of drawings of the tank and the various airplanes, installation drawings were prepared (dwgs. C18-64-770, C18-64-836, C18-64-768, C18-64-837, and C18-64-769, appendix B)

No reports are available on the installation of the 165-gal. knockdown range-extension tank for the P-80 airplane on any of the fighter airplanes subsequent to the P-80 and no reports have been located on the installation of the existing fire bomb (165-gal. range-extension tank) on

CONFIDENTIAL

CONFIDENTIAL

any of these airplanes. A study of reports 1, 2, and 3 on the testing of the 165-gal. knockdown range-extension tank indicates that very little of the data are applicable to its use as a fire bomb. The cancellation of the military characteristics covering the use of the fire bomb as a range-extension tank was the result of similar decisions (11).

2. Installation.

Clearances were checked and photographs of each installation were taken.

a. P-80 Airplane.

As the E47 fire bomb is primarily a modified 165-gal. droppable fuel tank, no great difficulty was experienced in installing the bomb on the P-80 airplane (photo. 14639, appendix A). It was noted that if the interference drag fairing was on the bomb, installation would be difficult. This was verified by personnel of the Bombing Branch, Air Materiel Command, and it was stated that one hour was needed for installing the droppable fuel tank. If a removable panel were located in the side of the fairing, making it possible to see the lugs, installation would be simplified.

b. P-82 Airplane.

The E47 fire bomb must be modified for use on the P-82 airplane, as the bomb rack pylon strikes the bomb at the forward end of the sump. When the bomb is mounted on the outboard racks (photo. 14640, appendix A) the interference is approximately 1/2 in.; when it is mounted on the center racks, the interference is approximately 2-1/4 in.

The clearance between the two fire bombs when mounted on the center racks is approximately 7/8 in. It appears that if the bombs are dropped in salvo, the possibility of their striking together, causing air burst and danger to the airplane, is great. If the bombs are dropped in train, the clearance seems sufficient. Electrical wiring of the fire bomb has been considered, and if this is done the center racks will have to be especially wired, as there is no wiring at this point on existing airplanes.

c. P-84 Airplane.

The E47 fire bomb, as designed, is not suitable for use with the P-84 airplane. When the bomb is mounted, the interference between the bomb and the landing gear door is approximately 1 in.; the clearance between the bomb and the fuselage is 7/8 in. When the landing gear is raised or lowered, the tire rubs the door at its extreme open position (photo. 14638).

3. Location of Igniters.

Test of the first two inert, unstabilized containers with M15 igniters at the nose and the tail established the proper testing procedure. It was found that on impact the igniters became detached from the container

CONFIDENTIAL

CONFIDENTIAL

and since only two were found, in a relatively swampy area, positive identification with respect to their location was impossible. Subsequently, an identifying color was added to the body of the igniters. The second test resulted in the recovery of both nose igniters, which functioned properly. Only one tail igniter was recovered and this had not functioned due to a broken arming wire, which was retained in the fuse. The third test resulted in 100% functioning of both nose and tail igniters.

4. Flight Tests of Model.

A total of six hours' flight time was registered on two model fire bombs. Inspection of the models at the end of this period failed to reveal any flaws.

V. DISCUSSION.

The fire bomb proved its effectiveness in the last war, even though the first bombs were of the most elementary type. Since that time many improvements have been made on the bomb. These improvements are the result of extensive test programs conducted in an attempt to ascertain the optimum type and size of bomb. It has been realized that an optimum streamlined fire bomb for all high-performance fighter aircraft will obviously be a compromise.

The 165-gal. jettisonable fuel tank was used as the major component of the E47 fire bomb. External igniters with fuzes of the inertia type were mounted in truncated fairings at the nose and the tail and were inclosed in removable fairings. Arming wires for both the fairings and fuzes were run through internal ducts to prevent their being carried away by the air stream. As can be seen from photo. 14596, appendix A, the bomb presents a clean, smooth surface to the air stream. Preliminary pressure tests of the bomb indicate that a hydrostatic pressure of 10 lb./sq. in. will not cause leakage.

The functioning efficiency of internal and external igniters has been the subject of many tests. It was determined from these tests that two external igniters were the most efficient, thus this type is being used on the E47 bomb. As the igniters at the nose and the tail are identical and are suitable for both NA and WP filling, procurement is simplified. The removable fairings are of clear plastic to permit inspection of the igniter prior to take-off.

Since the 165-gal. jettisonable fuel tank was designed primarily for the P-80 airplane, no difficulties were encountered in installing it on that airplane. As the interference drag fairing is attached to the tank before mounting on the wing it is impossible to see the bomb rack, thus making proper alignment between the suspension lugs and suspension hooks a matter of chance. A change is anticipated in the method of sway bracing which will necessitate only a minor change to the fire bomb.

CONFIDENTIAL

CONFIDENTIAL

When mounting the fire bomb on the P-82 airplane, interference between the top of the bomb and the wing rack pylon was encountered. The inboard pylons are equipped with bomb racks for both 14-in. and 30-in. suspension. As the fire bomb requires 14-in. suspension, the forward end of the pylon strikes the bomb at the forward end of the sump and the sway braces could not be extended far enough to support the bomb. When the lugs were lengthened 1/2 in., the pylons cleared the bomb. When the fire bomb was mounted on the outboard racks it was necessary to lengthen the lugs 2 1/4 in. The alterations required to make the E47 fire bomb suitable for the P-82 airplane are minor.

The E47 fire bomb is not suitable for installation on the P-84 airplane, as the landing gear door strikes the side of the bomb when it is 1 in. short of its maximum open position. The angle of the door when open, in relation to the bomb, is such that lengthening the suspension lugs does not remedy the difficulty. The only solution to this problem is to develop a new fire bomb with a diameter no greater than 24 in. A compromise must be accepted in the amount of incendiary fuel carried, in order to decrease the diameter of the bomb and thus facilitate mounting on all airplanes. A bomb of 24-in. diameter would have a capacity of approximately 100 gal., which would materially reduce the incendiary effect but which would not impair the over-all efficiency, it is believed.

The stability of the removable nose and tail fairings when in flight was questioned. Due to the unavailability of a high-performance fighter aircraft, the E47 bomb was given preliminary flight tests on a P-47 airplane at speeds up to 360 m.p.h. Motion pictures of the nose and tail fairings were taken in flight. A study of the motion pictures did not reveal any serious movement in these fairings, consequently it is presumed that the condition at high speeds will be satisfactory. The airplane was flown at a speed of 263 m.p.h. and the power setting noted; when the fire bombs were mounted and the airplane flown at the same power setting a speed reduction of 8 m.p.h. was noted. This reduction is .03% of the maximum. On this basis, which only can be checked by actual flight tests, there would be a loss of 21 m.p.h. with a power setting of 700 m.p.h. This figure seems to be low but may give some indication of the reduction in speed. These tests were conducted with empty tanks; if the tanks had been filled the reduction in speed would undoubtedly be greater.

No reports on the jettisoning or functioning of munitions dropped from high-performance jet fighter airplanes at high subsonic velocities have been found. It is known, however, that modified fire bombs have been dropped at Eglin Field, Fla., from the P-80 and P-82 airplanes. Informal discussion with personnel of Eglin Field, in May 1947, on the concept of fire bombs and spray tanks for the jet airplanes led to the decision to place arming wires and electrical wiring inside small-diameter metal tubing which is run through the inside of the bomb, to prevent their being carried away by the air stream. This method has proven satisfactory with spray tank E19R1.

CONFIDENTIAL

CONFIDENTIAL

It was also learned in discussions with personnel of the Air Materiel Command, Wright Field, that very little about the behavior of wing-mounted munitions when jettisoned at high speed could be predicted and that a program had been prepared to conduct flight and jettisoning tests with an XB-45 airplane instrumented with various cameras to record results. The problem of jettisoning munitions at high velocities is regarded as one of basic research by the AMC. It is anticipated that some additional means, such as hydraulic ejection cylinders, explosive cartridges or carbon dioxide bottles, may be required to jettison munitions at very high velocities. No provision can be made to strengthen the tanks at the ejector bearing surface until more data are available on the basic requirements. It is also anticipated that fairings to the wings may be necessary at very high velocities, especially through the transonic zone. The tumbling nature of the fire bomb, which apparently is the major factor in producing the fireball effect, would not be affected by retaining the interference drag fairings now in use on range-extension tanks. Therefore, it is indicated that a distinct advantage may accrue in the development of externally mounted munitions for higher velocity airplanes by retaining the fairings of the present fire bomb. The upper shell of the knockdown range-extension tank has been designed for right- and left-hand installation. The redesign of this part and the relocation of the fairing attachment holes to make a basic casing that will receive right- and left-hand fairings for any airplane is desirable.

The arming of munitions on release from present airplanes has been accomplished almost invariably by arming wires or similar mechanical devices. Spray tanks have been fired electrically. The use of electrical controls gives several advantages, such as safety in handling, storage, and flight, jettisoning in safe condition, and elimination of the drag of arming wires on munitions when jettisoned at high velocity. In discussions with personnel from the AMC, Wright Field, it was indicated that electrically fuzeed or armed munitions would replace the currently standardized arming-wire type of munitions at some future date. For the connection from shackle to bomb it was anticipated that a break-away coupling of the jack type would be developed. A current investigation by the Technical Command of a self-ejecting-type coupling for use with the wing-mounted munitions has been referred to AMC, Wright Field, for consideration. The first models of fire bombs are armed by arming wires. To obtain a fully electrically controlled munition, minute solenoids have been procured for locking the nose and tail fairings and a tentative design is being considered. A miniature motor also has been procured for use in the igniter fuze and a tentative design to give an electrically safetied air-arming fuze is being studied. The ultimate goal of electrically controlled munitions will be slower of accomplishment than the development of conventional types and must await a simultaneous solution for airplane, munitions, and fuze.

CONFIDENTIAL

CONFIDENTIAL

VI. CONCLUSIONS.

1. A fire bomb design based on the modification of the 165-gal. knockdown range-extension tank for the P-80 airplane, to incorporate external igniters inclosed within fairings at the nose and tail, will be satisfactory for the P-80, P-82, and P-86 airplanes, and possibly for the P-90 and subsequent fighter aircraft, and will be available for use in the shortest period of time.

2. The concurrent development of a fire bomb having a capacity of approximately 100 gal., a maximum diameter of 24 in., a fineness ratio of five to one, and identical in all other respects to the fire bomb mentioned in conclusion 1, for use with the P-80, P-82, P-84, P-86, P-88, and subsequent fighter aircraft, is necessary. This bomb will lead to the obsolescence of the bomb mentioned in conclusion 1.

VII. RECOMMENDATIONS.

None, since work on the development of a fire bomb for high-performance fighter aircraft is continuing.

VIII. BIBLIOGRAPHY.

1. AAFPGC Report, Serial no. 1-42-53, Test to Make Fire Bombs From Droppable Gas Tanks, Suspended Under Airplane, 29 March 1943.

2. AAFPGC Report, Serial no. 1-42-52, Supplementary Test to Make Fire Bombs From Droppable Gas Tanks, Suspended Under Airplane, 27 September 1943.

3. AAFPGC Report, Serial no. 1-44-2, Final Report on Fuel Tanks as Incendiary Bombs, 22 April 1944.

4. AAFPGC Report, Serial no. 1-44-33, Final Report on Test of Fire Bomb With Thickened Fuel, 26 June 1944.

5. G. Broughton, Weekly News Letter 15, OSRD, 16 September 1944.

6. TDMR 1089, Development of Fuze Adapters and Bursters for the Igniter, Incendiary Gasoline Tank.

7. TDMR 1205, High Altitude Field Tests of U.S. Navy Bomb, Mk. 66 Mod. O, as a Fire Bomb.

8. TDMR 1204, Field Testing of the 2,000-lb. Incendiary Bomb, Mk. 67.

9. TDMR 1110, Investigation of the 58-gal. Aircraft Jettisonable Fuel Tank Fire Bomb.

CONFIDENTIAL

CONFIDENTIAL

10. AAFSC, Serial no. CW 9-45-1, Final Report on Cold Weather Test of Fire Bombs.

11. TSEPP-524-1769, Conference in Regard to Standardization of External Jettison Fuel Tanks with Representatives of Engineering, Procurement, Maintenance and Supply Divisions.

CONFIDENTIAL

CONFIDENTIAL

APPENDIXES

Appendix A, Photos. 14355, 14596, 14594, 14619, 14639, 14640, and 14638.

Appendix B, Dwgs. C18-64-770, C18-64-836, C18-64-768, C18-64-837, and C18-64-769.

o

CONFIDENTIAL

CONFIDENTIAL

APPENDIX A

- Photo. 14355, Smoke Tank M10 Modified to Receive Igniters M15 at Nose and Tail.
- Photo. 14596, Fire Bomb E47 Mounted on P-80 Airplane Wing Tip.
- Photo. 14594, Fire Bomb E47 Mounted on P-47N Airplane.
- Photo. 14619, Fire Bomb E47 Mounted on P-47N Airplane, in Flight.
- Photo. 14639, Fire Bomb E47 Mounted on Wing of P-80 Airplane.
- Photo. 14640, Fire Bomb E47 Mounted on Outboard Wing Racks of P-82 Airplane.
- Photo. 14638, Fire Bomb E47 Mounted on P-84 Airplane.

CONFIDENTIAL

CONFIDENTIAL



SMOKE TANK M10 MODIFIED TO RECEIVE  
IGNITERS M15 AT NOSE AND TAIL

CONFIDENTIAL

CONFIDENTIAL

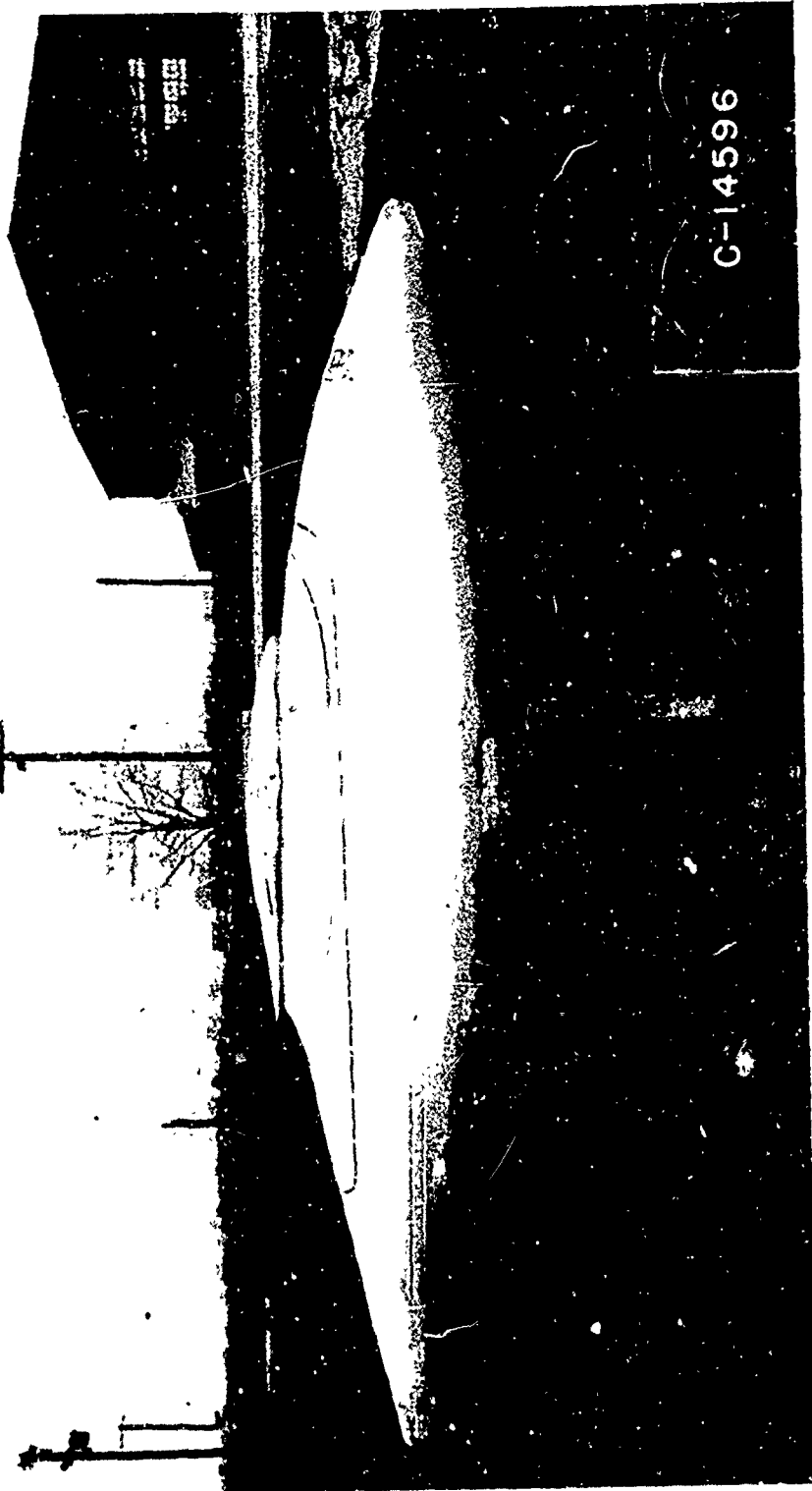

FIRE BOMB E47 MOUNTED ON P-80 AIRPLANE WING TIP

CONFIDENTIAL

RESTRICTED

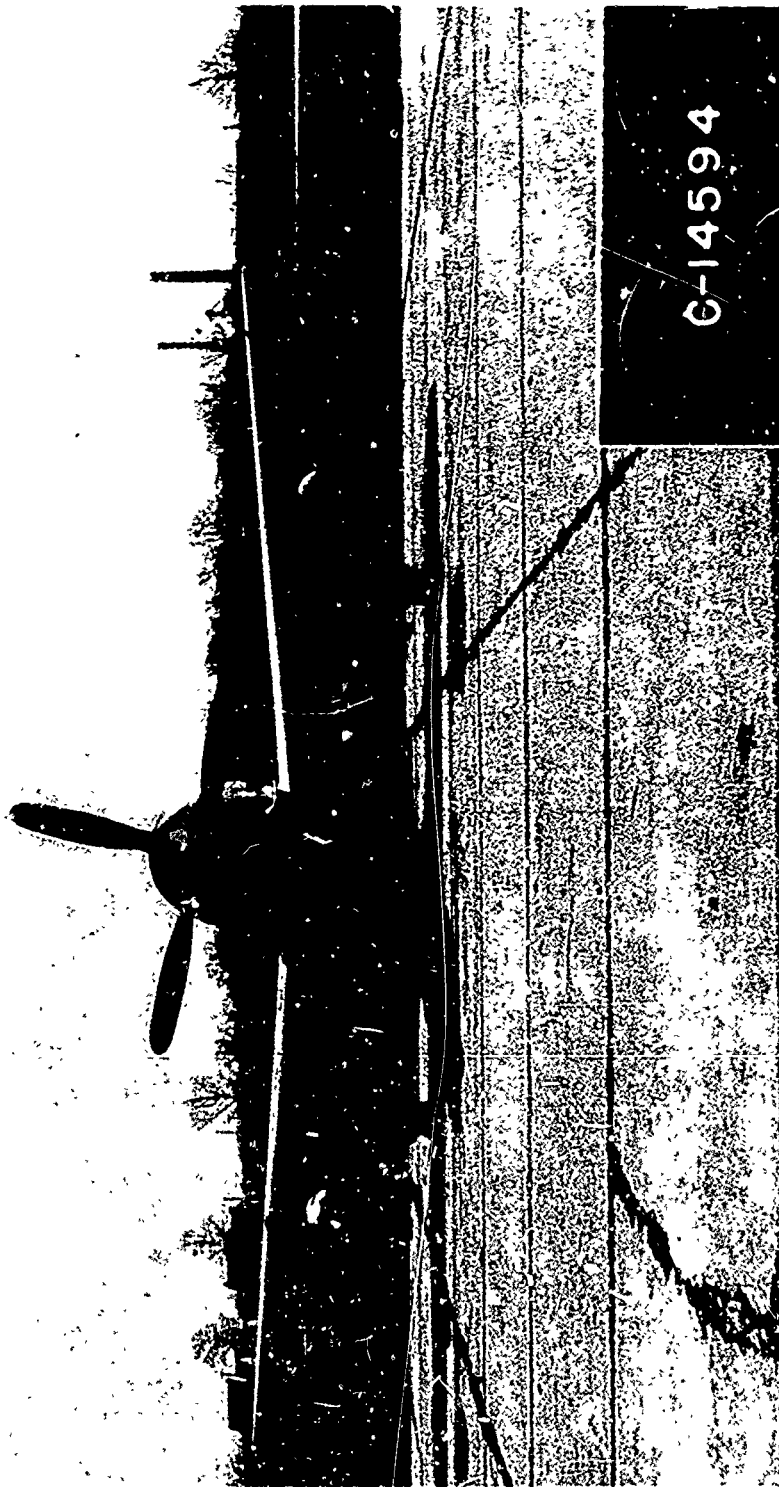

FIRE BOMB E47 MOUNTED ON P-47N AIRPLANE

RESTRICTED

RESTRICTED



FIRE BOMB E47 MOUNTED ON P-47N AIRPLANE, IN FLIGHT

RESTRICTED

CONFIDENTIAL

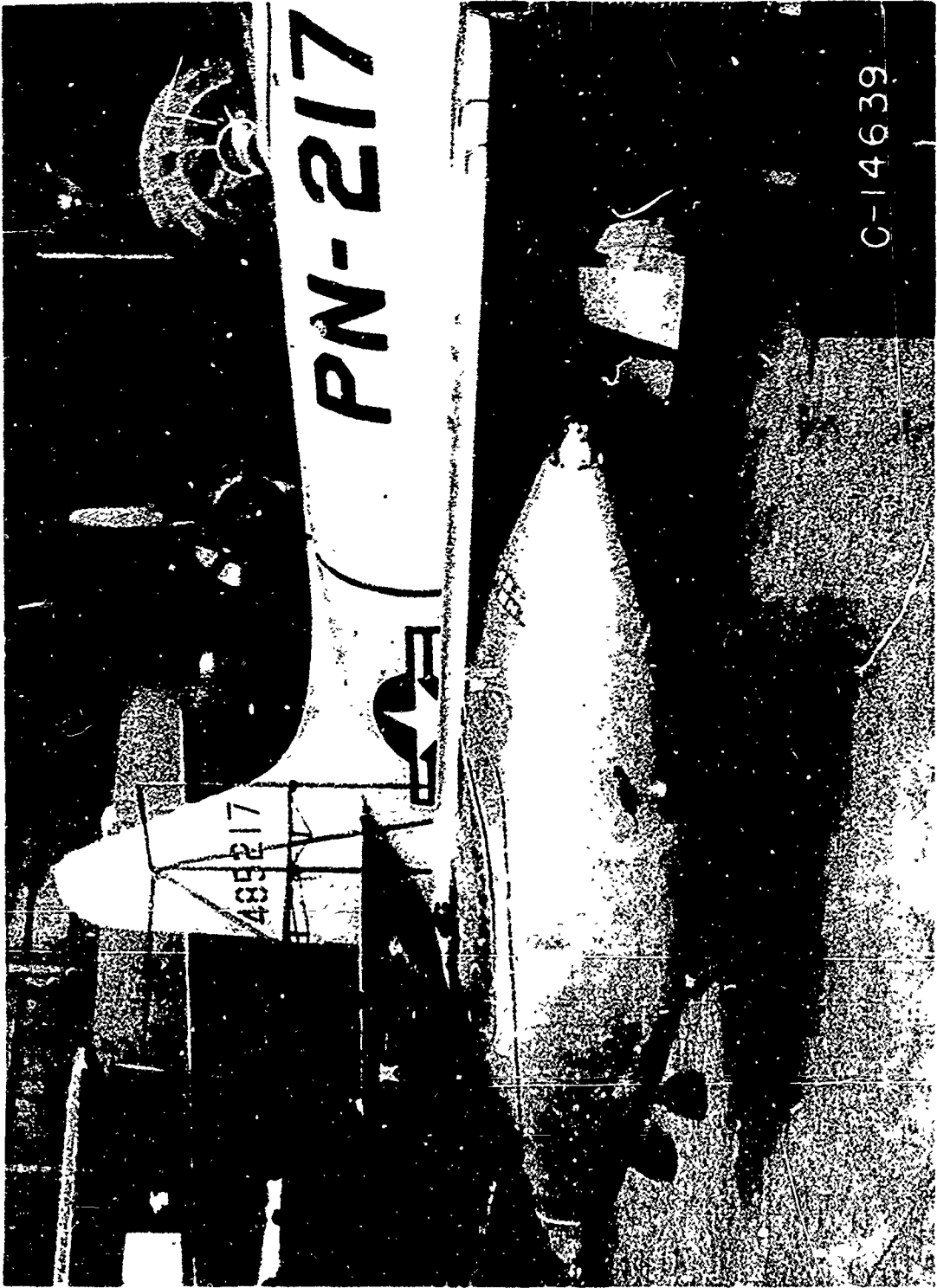

FIRE BOMB E47 MOUNTED ON WING OF P-80 AIRPLANE

CONFIDENTIAL

CONFIDENTIAL



C-14640

FIRE BOMB E47 MOUNTED ON OUTBOARD WING RACKS OF F-82 AIRPLANE

CONFIDENTIAL

CONFIDENTIAL



FIRE BOMB E47 MOUNTED ON F-84 AIRPLANE

CONFIDENTIAL

CONFIDENTIAL

APPENDIX B

Dwg. C18-64-770, Installation, Smoke Tank and Fire Bomb (XP-80 Airplane).  
Dwg. C18-64-836, Installation, Smoke Tank and Fire Bomb (XP-82B Airplane).  
Dwg. C18-64-768, Installation, Smoke Tank and Fire Bomb (XP-84 Airplane).  
Dwg. C18-64-837, Installation, Smoke Tank and Fire Bomb (XP-86 Airplane).  
Dwg. C18-64-769, Installation, Smoke Tank and Fire Bomb (XP-88 Airplane).

CONFIDENTIAL

CONFIDENTIAL

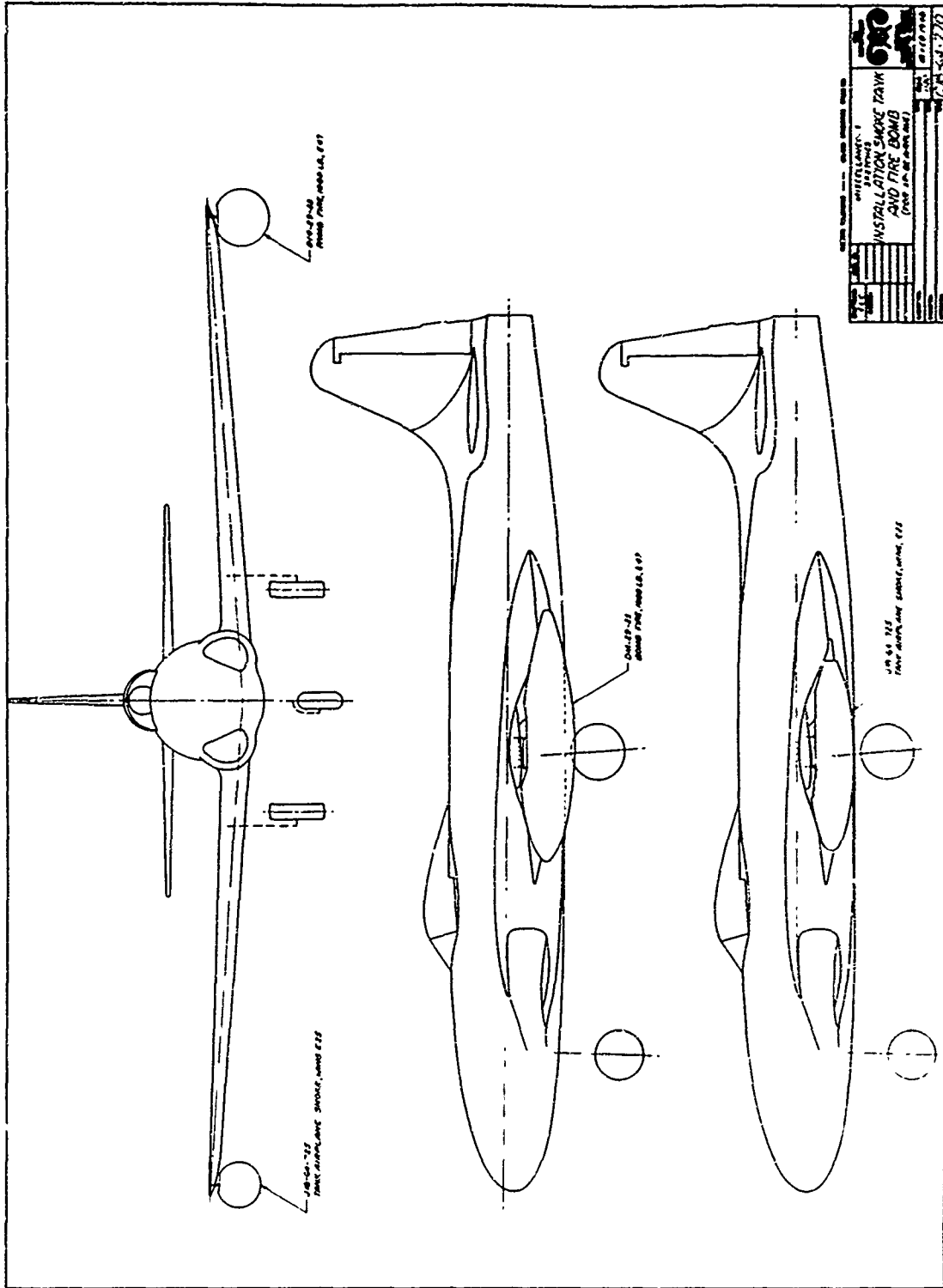

CONFIDENTIAL

CONFIDENTIAL

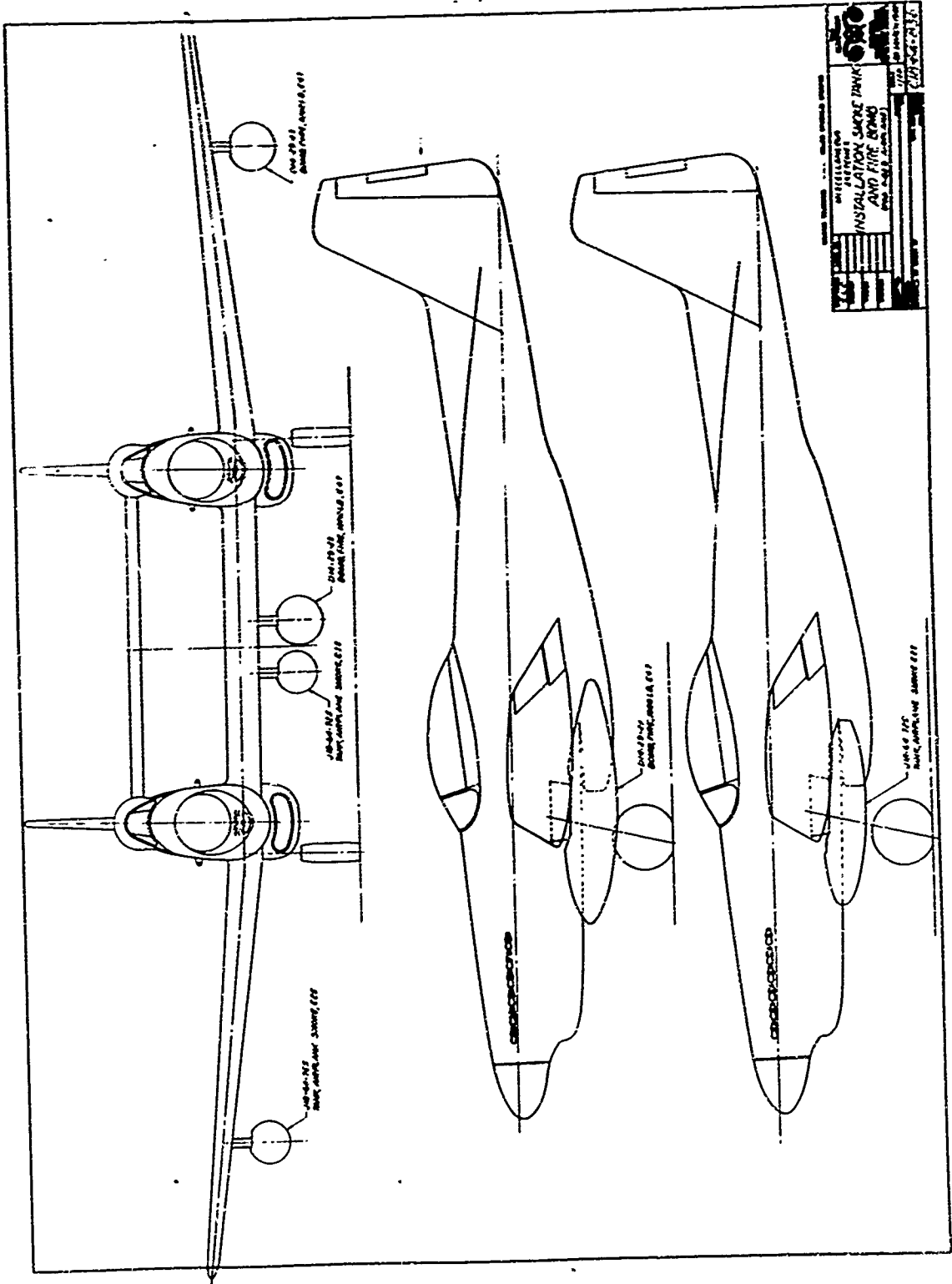

CONFIDENTIAL





CONFIDENTIAL

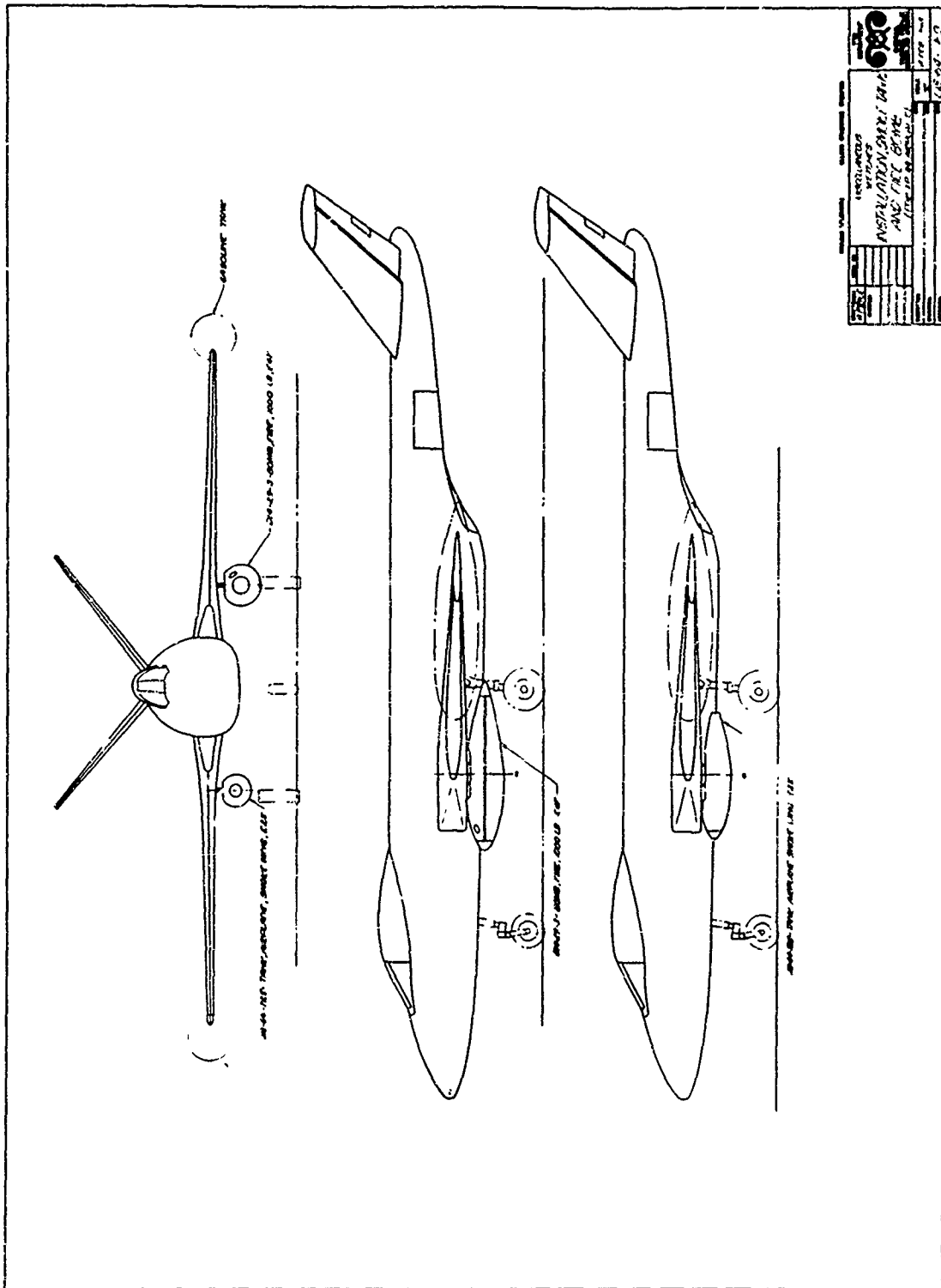

CONFIDENTIAL

**THIS REPORT HAS BEEN DELIMITED  
AND CLEARED FOR PUBLIC RELEASE  
UNDER DOD DIRECTIVE 5200.20 AND  
NO RESTRICTIONS ARE IMPOSED UPON  
ITS USE AND DISCLOSURE.**

**DISTRIBUTION STATEMENT A**

**APPROVED FOR PUBLIC RELEASE;  
DISTRIBUTION UNLIMITED.**