

UNCLASSIFIED

---

---

AD 400 525

*Reproduced  
by the*

ARMED SERVICES TECHNICAL INFORMATION AGENCY  
ARLINGTON HALL STATION  
ARLINGTON 12, VIRGINIA



---

---

UNCLASSIFIED

NOTICE: When government or other drawings, specifications or other data are used for any purpose other than in connection with a definitely related government procurement operation, the U. S. Government thereby incurs no responsibility, nor any obligation whatsoever; and the fact that the Government may have formulated, furnished, or in any way supplied the said drawings, specifications, or other data is not to be regarded by implication or otherwise as in any manner licensing the holder or any other person or corporation, or conveying any rights or permission to manufacture, use or sell any patented invention that may in any way be related thereto.

63-5-1

FTD-TT-62-1659

CATALOGED BY ASTIA  
AS AD NO. 400525

# TRANSLATION

A STUDY OF THE WEAR-RESISTANCE OF ENAMEL COATINGS  
WITH REFERENCE TO THE LIFE OF MACHINE PARTS

By

V. S. Lomakin and V. I. Savchenko

## FOREIGN TECHNOLOGY DIVISION

AIR FORCE SYSTEMS COMMAND

WRIGHT-PATTERSON AIR FORCE BASE

OHIO

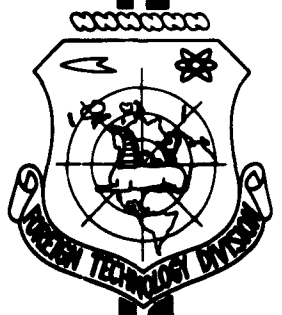

## UNEDITED ROUGH DRAFT TRANSLATION

A STUDY OF THE WEAR-RESISTANCE OF ENAMEL COATINGS WITH  
REFERENCE TO THE LIFE OF MACHINE PARTS

BY: V. S. Lomakin and V. I. Savchenko

English Pages: 36

SOURCE: Russian Book, Treniye I Iznos V Mashinakk,  
Izdatel'stvo Akademii Nauk SSSR, Moskva,  
1960, pp 63-92

S/711-60-14-0-3-13

THIS TRANSLATION IS A RENDITION OF THE ORIGINAL FOREIGN TEXT WITHOUT ANY ANALYTICAL OR EDITORIAL COMMENT. STATEMENTS OR THEORIES ADVOCATED OR IMPLIED ARE THOSE OF THE SOURCE AND DO NOT NECESSARILY REFLECT THE POSITION OR OPINION OF THE FOREIGN TECHNOLOGY DIVISION.

PREPARED BY:

TRANSLATION SERVICES BRANCH  
FOREIGN TECHNOLOGY DIVISION  
WP-AFB, OHIO.

A STUDY OF THE WEAR-RESISTANCE OF ENAMEL COATINGS  
WITH REFERENCE TO THE LIFE OF MACHINE PARTS

V. S. Lomakin and V. I. Savchenko

Enameling of the surfaces of machine parts subjected to wear may be regarded as one of the possible trends in the search for new ways to improve their wear-resistance. Up to the present time enameling has not been used for this purpose, since the compositions and technology of application of wear-resistant enamels most suited for various conditions of operation of parts subjected to wear have not been found. It has not been established for which machine parts or in which areas of machine construction the use of wear-resistant enameling will be efficient and advantageous.

The basic over-all properties of the enamel coatings used at the present time (mainly for objects of everyday use and in sanitary engineering), their great hardness, resistance to certain aggressive acid media, comparative ease of application on steel, the possibility of obtaining durable joining with steel, and also their cheapness, give us assurance that work on the problem of wear-resistant enameling is timely and that the solution to this problem should prove to be very effective in the national economy.

In the present study a laboratory testing procedure is developed for comparative evaluation of materials during the simultaneous action of moving abrasive particles and an aggressive liquid medium. Comparative tests of various steels and of enamel coatings used in industry, as well as tests of experimental enamel coatings were performed according to this procedure under various test conditions. The laboratory studies and enameling of components for industrial tests were carried out at the Artem Enameling Factory in Lugansk. Moreover, industrial tests of enameled mining-machine components were performed in the coal mines of the Donbas.

Previously Developed Methods of Testing for Wear of Enamel  
Coatings

The literature contains very sparing data concerning the methods of testing for wear of enamel coatings and concerning the results of these tests.

Kinsey determined the wear of enamel coatings during the action of porcelain beads for a certain length of time on an enameled layer within a hollow component of bushing type. After 40 hours of tests the loss in weight of the enamel layer amounted to about 0.7-1.5% of the weight of the enamel [1].

Hartsis and Harrison determined the wear-resistance of enamel coatings from the loss of their initial sheen after a certain number of vibrations on an enameled surface of a mixture of moist abrasive powder and heavy beads. According to Hartsis and Harrison, 50% of the sheen remains on ordinary enamels after 5500 vibrations and on soft enamels after 3400 vibrations [1]. A method of determining the wear of an enamel layer from the loss of sheen of the enamel and of decreas-

ing the weight of the specimens under the action of a freely falling sand stream is also known.

The given data on wear of enamels cannot be compared with the data on wear of metals, owing to the specific nature of the test conditions.

One of the authors of the present article previously carried out [2] laboratory tests on wear of certain enamel coatings used in the production of sanitary-engineering components for the purpose of ascertaining the possibility of using them in the cylinders of sludge pumps. The wear of the specimens in these tests was achieved in the presence of a clay mortar containing quartz sand on the surface; the friction occurred against coupled rubber specimens in back-and-forth motion. The tests showed that enamels can compete with hard steels with respect to wear-resistance. However, the effect of the composition of the enamels and other factors on their wear-resistance was not studied. The tests themselves were also of specific nature.

#### Apparatus for Testing Specimens for Wear

In order to carry out laboratory studies of wear of enamel coatings with reference to conditions of wear by free abrasives during the simultaneous action of a liquid aggressive medium, a special apparatus consisting of the following three main parts was constructed: a tank, a mandrel to hold the specimens, and a driving mechanism (Fig. 1).

Six specimens 1 in the form of a plate with the dimensions  $92 \times 40 \times 5$  mm and with rounded edges are secured in the grooves of mandrel 2. These grooves are cut at an angle of  $30^\circ$  to the axis of the mandrel.

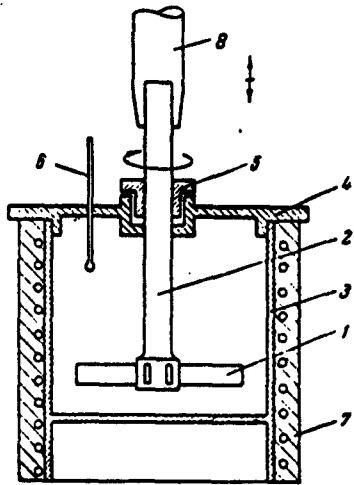

Fig. 1. Apparatus for testing for wear.

The mandrel with the specimens fits freely in tank 3, which is in the form of a cast iron ingot with an enameled inner cavity. The tank was enameled in the given case, in order to protect it from corrosion. The tank is secured on the table of the machine by a flange located in its lower part and is covered in its upper part by lid 4, which with the aid of guide bushing 5 reliably centers the mandrel with respect to the tank cavity.

Before the lid is put on, the tank is filled with the appropriate working fluid. With the aid of a gasket and a gland the lid hermetically seals the tank. In order to equalize the pressure inside the tank during periods of operation, a threaded opening is made in the lid, and the blower pipe is screwed into this opening. This same opening serves as the emplacement for thermometer 6 or a thermocouple to determine the temperature of the working fluid inside the tank.

In order to create the test temperature schedule, the outer surface of the tank is coated with electrically insulating heat-resistant material 7, around which an electric coil is wound. The heating temperature of the tank, and consequently the temperature of the working fluid, is controlled by a rheostat.

The mandrel is connected by its conical part to the spindle of honing machine 8, which is used as the driving mechanism. Owing to the rotational and back-and-forth motion of the spindle of the honing machine, the working fluid inside the tank is stirred energetically,

as a result of which the specimens come in contact with different particles of the abrasive.

#### Preliminary Test Conditions

The purpose of the preliminary tests was to ascertain the effect of certain factors on the wear of the specimens and on this basis to choose a procedure for carrying out comparative tests of various materials. The tests were performed on specimens made of rolled steel 30 in the delivery state.

The specimens were enameled with enamel No. 401 (green enamel). The specimens had previously been coated with enamel base No. 18/27/35. Steel 30 and enamel No. 401 were used constantly in all the experiments with the exception of the studies of the effect of the composition of the enamels on wear.

The tests were carried out at a constant rotational speed of the specimens; the number of rotations of the spindle (the mandrel with the specimens)  $n = 93$  rpm. Bearing in mind that the specimens in the mandrel are located perpendicular to the axis, the rate of relative displacement is different for individual sections of the specimens; the maximum rate is that of the peripheral sections of the specimens ( $V_{\max} = 64.3$  m/min), while the minimum rate occurs at the base of the mandrel ( $V_{\min} = 17.5$  m/min).

The surface of contact between the specimen and the working fluid is equal to the total surface of the specimen minus the part located in the mandrel and amounted to  $76.3$  cm<sup>2</sup>.

The abrasive content in the tank was kept constant and equal to 5 kg. After 8 hours of testing the abrasive was replaced by a new one. The tests were carried out simultaneously on six specimens; the arith-

metic mean of the wear of three specimens was taken as the test result. In individual cases additional control tests were made.

Owing to the low weight of the specimens tested (135 g on the average), it was possible to determine the wear from the loss in weight of the specimens after eight hours of operation. The weighing was done on an analytical balance with an accuracy to the nearest 0.1 mg. The specimens were carefully washed with alcohol and dried before being weighed.

The test conditions remained constant during all the experiments and varied only during the study of the effect of the corresponding factors on wear.

#### Variation in Wear as a Function of the Time of Operation

The purpose of the experiments described in the present section was to determine experimentally the optimum test length and to study the effect of the microgeometry of the surfaces on the wear of these surfaces by a free abrasive.

The tests were performed on specimens coated with enamel No. 401 and on unenameled specimens made of steel 30 (in delivery state), using moist and dry abrasive (quartz sand of the Novoselovo deposits) of constant composition. The granulometric composition of the sand (composition No. 1) is given in Table 1.

TABLE 1  
Granulometric Composition (in %) of Quartz Sand Used in Tests

No. of specimens	Size of opening of sieve									Grinding	
	0,840	0,500	0,420	0,297	0,210	0,149	0,105	0,070	0,053		
1	0,02	0,70	4,80	20,80	30,40	38,70	4,80	0,10	0,02	0,18	Initial
2	—	—	—	1,00	6,60	33,00	21,80	11,80	3,50	22,30	8 hours
3	—	—	—	—	0,80	17,40	27,40	19,80	7,80	27,00	16 hours
4	—	—	—	—	—	4,2	23,3	32,0	10,6	29,9	24 hours

\* The above sand compositions correspond to the average grain size (fractions):  
No. 1) 0.162 mm; No. 2) 0.116 mm; No. 3) 0.081 mm; No. 4) 0.064.

The tests involving dry abrasive were carried out simultaneously on three enameled and three unenameled specimens of steel 30. The abrasive had previously been thoroughly dried in a desiccator at 150-200°.

Table 2 shows the results of the experiments with dry abrasive, while Table 3 shows the results in the case of moist abrasive. The initial moisture of the sand amounted to 10% (500 ml of water were taken for every 5000 g of sand). The change in the moisture of the sand during the tests was not determined. The tests with moist abrasive were performed only on enameled specimens.

TABLE 2  
Dependence of Wear of Specimens on Operating Time (dry abrasive)

Specimens	Wear index	Length of test, min.						
		5	10	15	30	60	120	240
Enameled	average wear, mg	3,3	2,7	2,1	2,0	1,6	1,9	3,8
	rate of wear, mg/min	0,66	0,27	0,14	0,067	0,027	0,016	0,016
Unenameled	average wear, mg	4,0	3,3	2,4	1,0	0,5	1,5	2,6
	rate of wear, mg/min	0,8	0,33	0,16	0,033	0,008	0,012	0,011

Table 4 shows the results of tests of enameled specimens (enamel No. 401) with quartz sand of various compositions serving as the abrasive, while Fig. 2 shows a graphic dependence expressing the increase in the wear of enameled specimens as a function of the grain size of the abrasive. The maximum wear is observed in the case of the most coarse-grained (initial) abrasive.

TABLE 3

Dependence of Wear of Enameled Specimens on Operating Time (moist abrasive)

Wear index	Length of test, min							
	5	10	15	30	60	120	240	480
Average wear, mg	1,7	4,0	3,0	3,0	2,7	2,9	4,4	10,4
Rate of wear, mg/min	0,34	0,40	0,20	0,10	0,045	0,024	0,02	0,021

The graphs in Fig. 3 were plotted on the basis of the test results and show the change in the wear of enameled and steel specimens as a function of the test length.

TABLE 4

Dependence of Wear of Enameled Specimens on the Composition of the Abrasive (quartz sand)

No. of composition	Average grain size, mm	Average wear after 8 hours, mg
1	0,182	7,6
2	0,116	3,7
3	0,081	2,0
4	0,064	1,5

Analyzing the results of the tests, we can conclude that the established concept of periods of wear (a period of initial increased wear and a period of normal wear) can be used completely even in the case of wear of metals and enameled coatings by a free abrasive.

The length of the initial period of wear by dry abrasive is approximately the same for both steel and enameled specimens. In this period a high rate of wear was observed, a rate which attained a constant value after approximately 60 minutes of operation in the case of steel specimens and after 120 minutes of operation in the case of enameled specimens.

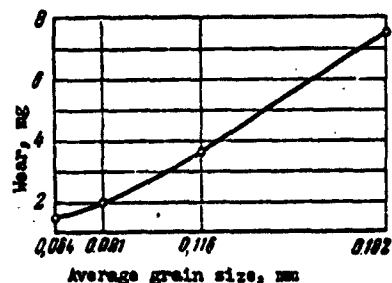

Fig. 2. Dependence of wear of enameled specimens on the grain size of the abrasive (quartz sand)

In the case of wear in moist abrasive the period of initial increased wear of enameled specimens was approximately twice as much as the case of wear in dry abrasive.

The high rate of wear of the steel specimens during the wearing-in period is attributed by the authors to the effect of residual crests on the friction surface and also to a change in the microtopography of the steel surfaces during the wearing-in process. This is confirmed by a quantitative estimate of the roughness of the surfaces before and after the tests. The roughness of the surfaces of the steel specimens before the tests amounted to  $H_{CK} = 0.5-0.8\mu$  (determined on a profilograph of the Levin system, type IZP-17). After the tests the roughness of the most greatly worn surface of the specimens amounted to  $H_{CK} = 0.1\mu$ , i.e., it decreased considerably.

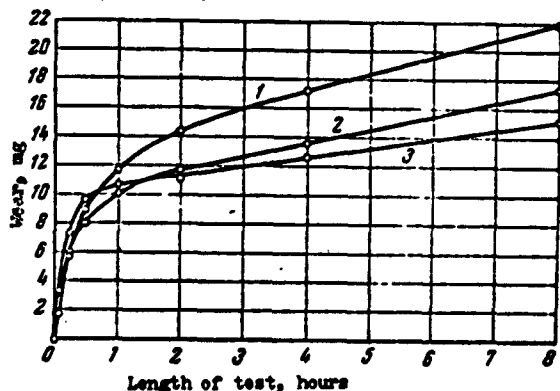

Fig. 3. The change in the wear of the specimens as a function of the length of the tests.

1) enamel No. 401 in moist abrasive; 2) the same enamel in dry abrasive; 3) steel 30 in dry abrasive

The wear of the specimens is not the same over the entire surface; those sections the rate of relative displacement of which is maximum suffer the most wear.

The working surfaces of the enameled and steel specimens lost their luster as a result of the action of the abrasive. However, no change in the magnitude of the roughness of the enameled surfaces was noted.

Taking into account the high degree of smoothness of the enamel layer, it was possible to assume that its rate of initial wear must be low and close to the rate corresponding to the period of normal wear. Indeed, as can be seen from the results of the experiments,

the rate of initial wear of the enamel layer is much higher than the rate of steady-state wear.

The cause of the initial increased wear of the enamel layer and the stabilization of the wear after further wearing of the layer is attributed to the properties of the silicates of the vitreous enamel surface layer.

The resistance of the enamels to abrasive wear may be regarded as the result of two components: the abrasion resistance of the surface layer itself and the rupture strength of the structure of the underlying enamel. A determination of the microhardness of the enamel layer on the PMT-3 instrument showed that the microhardness of the enamel layer is the same over the entire surface of the specimens (those subjected and those not subjected to wear). In the case of enamel No. 401  $H_{\mu} = 710-720 \text{ kg/mm}^2$ . A certain decrease in the microhardness of the enamel layer was observed only after prolonged tests in an aggressive acid medium.

On the basis of the fact that the minimum test length should encompass the initial period of wear and a sufficiently long part of the period of normal wear, the length of one test was taken to be eight hours. In order to eliminate the effect of the surface layer of the specimens on the wear, the remaining tests involving the study of the patterns of wear were performed on specimens which had undergone a period of initial wear.

#### The Effect of the Abrasive on Wear

The abrasives used in the tests were quartz sand of the Novoselovo deposits of four granulometric compositions (unground and ground in a ball mill for 8, 16, and 24 hours) and two types of crushed coal

(anthracite brand A and gas coal brand G).

The tests were carried out with dry abrasives, for which purpose the abrasives were thoroughly dried beforehand in a desiccator at 150-200°.

The grain size of the abrasive does not remain constant during the tests, since the abrasive is ground down during the process of operation. The granulometric composition of the abrasive (composition No. 1) before testing and after 8 hours of testing is given in Table 5 for comparison.

TABLE 5

Granulometric Composition (in %) of the Abrasive (quartz sand, composition No. 1) Before Testing and After Eight Hours of Testing.

State	Sieve numbers									Passed through all the sieves
	0,840	0,590	0,40	0,279	0,210	0,140	0,105	0,075	0,053	
Initial	0,02	0,70	4,60	20,60	30,40	38,70	4,60	0,10	0,02	0,16
After testing	—	0,20	1,60	6,80	20,00	39,80	12,80	6,20	1,80	10,80

As can be seen from Table 5, the average grain size of the abrasive of composition No. 1 after 8 hours of testing decreased from 0.182 mm to 0.15 mm. The decrease in the grain size of the abrasive during the tests is caused by its granulation and pulverization.

Table 6 gives the results of tests of enameled and steel specimens (steel 30 in delivery state) with crushed coal used as the abrasive.

The granulometric composition of the crushed coal is shown in Table 7.

As can be seen from the test results obtained, when coal is used as the abrasive, increased wear of the steel specimens is observed in comparison with the enameled specimens. On the other hand, when

quartz sand was used as the abrasive, the reverse picture was observed, i.e., greater wear of the enameled specimens in comparison with the steel specimens.

Coal has considerably less hardness than quartz sand. The increased wear of steel specimens occurring when coal is used as the abrasive is due to the large size of the coal particles (grains). From Table 7 it can be seen that the size of the particles of the crushed coal used in the tests is much greater than the size of the grains of quartz sand (cf. Table 5).

TABLE 6  
Wear of Specimens When Crushed Coal is Used As the Abrasive

Coal	No. of composition	Average wear after 8 hours, mg	
		Enamel No. 401	Steel 30
Anthracite	5	14,5	38,9
Gas coal	6	6,1	15,9

We can judge the effect of the hardness of the abrasive particles on wear from a comparison of the wear suffered by both steel and enameled specimens, when anthracite and gas coal are used as the abrasives (cf. Table 6). The granulometric composition of these coals is approxi-

mately the same. However, when anthracite coal, which is harder than gas coal, is used, greater wear of the specimens is noted.

TABLE 7  
Granulometric Composition of Coal (in %) Before Testing and After 8 Hours of Testing

Coal	No. of composition	Before and After testing	Residue on Sieve			
			9 mm	3 mm	1,2 mm	-1,2 mm*
Anthracite	5	Before	0,0	100	—	—
"	5	After	0,0	68,1	28,4	5,5
Gas coal	6	Before	0,0	100	—	—
"	6	After	0,0	78,5	19,7	3,8

\* The minus sign before the sieve opening indicates that a residue of this magnitude passed through the given sieve.

As a result of the lower hardness of coal in comparison with quartz sand and also due to its great brittleness, the coal is greatly pulverized during the tests. Gas coal, which is less brittle, is pulverized less than anthracite.

Repeated tests for wear of enameled specimens, where the abrasive used was anthracite, which remained in operation for 8 hours, i.e., was subjected to additional pulverization, showed that the wear after 8 hours of operation amounted to 1.3 mg.

Taking into account the great inhomogeneity of the granulometric composition of the coal and the intense pulverization of it occurring during the tests, and also its lower abrasive power, the abrasive used in the remaining experiments was quartz sand of the Novoselovo deposits (composition No. 1), the most coarse-grained, which creates more rigorous wear conditions than the other compositions. Every 8 hours the sand was replaced by fresh sand.

On the basis of the studies made we can conclude that the enamel layer is highly wear-resistant, when coal is used as the abrasive.

#### The Effect of Moisture of the Abrasive on Wear

In order to study the effect of moisture of the abrasive on the wear of an enamel coating, tests were carried out with different weight concentrations of water, ranging from 0 to 100%, in quartz sand of composition No. 1.

Table 8 shows the results of tests of enameled specimens for various degrees of moisture of the abrasive.

As can be seen from the results of the tests, the wear of enameled specimens in moist abrasive increased in comparison with wear in dry abrasive. This is due to the fact that the silicates of the

TABLE 8

Wear of Enamelled Specimens  
For Various Degrees of  
Moisture of the Abrasive

Weight concen- tration of water in the abrasive, %	Average wear after 8 hours, mg
0	7,6
5	10,2
10	10,4
15	13,1
50	11,1
100	14,2

surface layer of vitreous enamel, inter-acting with the water, are hydrolyzed. Alkali silicates form a caustic alkali and silicic-acid gel as the reaction products, the first of which can be freely washed out, while the second remains on the surface in the form of a more or less uniform layer. This layer decreases the rate of further rupture of the underlying

silicates. This process apparently occurs most intensely at the beginning of the test, which explains the initial increased wear of the enamel layer (cf. Fig. 3). The thicker or denser this layer is, the more slowly the diffusion of the water through it occurs, and the more slowly the process of rupture takes place.

#### Comparative Tests for Wear of Metallic Specimens in Dry Abrasive

Let us give brief data concerning the steels from which the test specimens were made.

1. Steel 20, rolled, in delivery state. Microstructure ferrite-perlite. Chemical composition: 0.21% C, 0.52% Mn, 0.25% Si.
2. Case-hardened steel 20. Heat-treatment schedule: case-hardening in a solid carburizer at 920-940°, normalizing at 840-850°, hardening at 780°-800°, tempering at 180° with air-cooling. Depth of case-hardened layer 0.7 mm. Carbon content in case-hardened layer 1.05%. Microstructure martensite.
3. Steel 30, rolled, in delivery state. Microstructure ferrite and perlite. Chemical composition: 0.29% C, 0.7% Mn, 0.28% Si..

4. Steel 30, chrome-plated. Chrome-plating dense "streamlet"; thickness of chrome layer 0.05 mm.

5. Steel U10A, hardened. Heat-treatment schedule: hardening at 800°, cooling through water in oil, tempering at 180° with oil quenching. Microstructure martensite. Chemical composition: 0.97% C, 0.23% Mn, 0.21% Si.

6. Steel KhVG, hardened. Heat-treatment schedule: hardening at 830°, tempering at 180° with oil-quenching. Microstructure martensite. Chemical composition: 1.02% C, 0.96 Mn, 0.25% Si, 1.1% Cr, 1.3% W.

TABLE 9

Results of Tests for Wear of Metallic Specimens in Dry Abrasive

Material	Heat Treatment	Microhardness $H_{\mu}$ kg/mm <sup>2</sup>	Average wear after 8 hours, mg
Steel 20, rolled	in delivery state	378	2,3
Steel 20	case-hardening, hardening, and tempering	1100	0,6
Steel 30, rolled	in delivery state	224	2,2
Steel 30, chrome-plated	—	1045	0,4
Steel U10A	hardening and tempering	1020	0,9
Steel KhVG	idem	1030	0,8

The final mechanical treatment of the specimens of different steels consisted of surface-finish grinding and polishing. In order to eliminate the effect of the surface roughness on the wear, the specimens subjected to the tests had already undergone a period of initial wear. The microhardness of the specimens was determined on the PMT-3 instrument. The tests were performed in dry abrasive of composition No. 1 (quartz sand). The results of the tests are shown in Table 9.

From Table 9 it can be seen that metals with great hardness possess the greatest wear-resistance. The tests performed show that the steels studied (the heat-treated ones, in particular) under conditions of wear by dry quartz sand possess considerably greater wear-resistance than enamels.

#### The Effect of Acid Solutions on Wear

Under the conditions of operation of mining, construction, and other machines (not to mention machines used in the chemical industry) the wear of parts is in many cases caused not only by a purely abrasive action, but also, to a considerable extent, by the chemical action of the medium.

The short life of mining machines and mechanisms is due, to a considerable extent, to the aggressiveness of mine waters. Mine waters are metamorphosed underground waters uncovered by mining operations and drained by them. The direction in which the processes of metamorphosis of underground waters occur is influenced by an increase in the mineralization of the water when it is filtered at high speeds through broken rocks and by the leaching out of the water and the simultaneously accelerated process of oxidation of sulfate rocks (pyrites). The mine waters pumped out onto the surface are intensely mineralized and are contaminated with suspensions of mineral and organic origin. All mine waters are turbid (in many mines this is due to the presence of iron salts) and have a constantly or periodically (during periods of spring-time influxes of water) acidic reaction.

More than 80% of mine waters are sulfate waters. The main sources of the sulfates dissolved in the water are various sedimentary rocks containing gypsum  $\text{CaSO}_4 \cdot 2\text{H}_2\text{O}$ .

Thus the main characteristic features of underground waters, which include mine waters, are the exceptional diversity of their chemical compositions and the considerable fluctuation in the extent of mineralization of the waters (from fresh water to brine).

The acidity of mine waters is caused by the presence in the water of free sulfuric acid and iron and aluminum salts. The complexity and diversity of the conditions characteristic of the appearance and increase of acidity of mine water complicate the struggle against acidity and the prevention of its appearance.

It has been established by many observations that acidic waters first appear in mines during the intensified spring-time influxes of water; very often the acidity of the water remains during the entire time of operation of the mine.

From the very nature of the chemical reaction occurring during the oxidation of a sulfur pyrite by oxygen which is dissolved in water and which causes the appearance of iron salts and free sulfuric acid in mine water we can conclude that an increase in the acidity of mine water is caused by a large quantity of oxygen dissolved in the water, while a large quantity of oxygen can only exist in waters connected with the atmosphere.

Acidic water quickly destroys mining machines and mechanisms; thus the impellers of pumps and slide valves in certain cases are destroyed within a week, while guiding devices are destroyed within one to three months. The solid impurities of mine waters, in the presence of acidity, destroy the protective oxide films which form on the inner surfaces of pipelines and pumps that come in contact with acidic water, as a result of which the destruction of the equipment reaches a considerable intensity. Pumps in mines working anthracite

beds are put out of commission especially fast. In this case the pumps wear out quickly as a result of the unfavorable combination of the acidity of the waters (however slight) and the abrasive properties of anthracite fines.

The equipment used in coal-enriching plants, where mine waters are widely used for the enrichment of the coal, operates under very unfavorable conditions.

Many studies of concrete of various compositions and densities have shown that in the case of aggressive waters acting on concrete the most corroding action is that of acidic waters. These waters quickly (within several days) destroy even dense concrete. Acids cause catastrophically extensive wear of the equipment used in chemical and other industries.

Taking into account the increased acid-resistance of enamels, it seemed expedient to perform tests on the wear of enamel coatings in aggressive media (acidic waters) and to perform analogous comparable tests on metals.

The tests were performed on specimens made of steel 30 in delivery state and coated with enamel No. 401. Quartz sand of composition No. 1 with a moisture content of 50% (2000 ml of sulfuric-acid solution for every 4000 g of sand) was used as the abrasive. The tests were made in solutions containing 0.01, 0.5, 1.0, and 2%  $H_2SO_4$ . The other conditions remained unchanged.

Table 10 gives the results of tests of enameled and steel specimens for different concentrations of sulfuric acid, while the graphs in Fig. 4 are plotted on the basis of these results and show the dependence of the wear of steel and enameled specimens on the concentration of sulfuric acid in the solutions.

TABLE 10

Wear of Specimens with Different Concentrations of Sulfuric Acid in the Solutions

Concentration of H <sub>2</sub> SO <sub>4</sub> in solutions, %	Average wear after 8 hours, mg	
	Steel 30	Enamel No. 401
0	51,3	11,1
0,1	68,4	16,9
0,5	377	63,6
1	426	93,7
1,5	450,2	101,3
2	471,4	103,8

From the results of the experiments it can be seen that with the presence of sulfuric acid in the water the wear resistance of both steel and enamel increases. The wear of steel increases particularly intensely. Thus even with a very insignificant concentration of sulfuric acid in water (0.1% H<sub>2</sub>SO<sub>4</sub>) the wear of steel specimens is four times greater than that of enameled specimens, while at a concentration equal to 0.5% H<sub>2</sub>SO<sub>4</sub> it is six times greater. The wear of steel specimens is very high even in moist abrasive not containing acid.

Enamel No. 401, with which the specimens were coated, is a nonacid-resistant enamel. However, even this enamel has a great advantage over steel 30 in the case of wear by an abrasive moistened with an acid solution.

In order to establish the degree of solubility of steel and enamels in sulfuric acid, in addition to the tests described above, tests of enameled and steel specimens without abrasive in a solution containing 0.5% H<sub>2</sub>SO<sub>4</sub> were performed (Table 11).

TABLE 11

Wear of Specimens in a Solution of Sulfuric Acid with 0.5% H<sub>2</sub>SO<sub>4</sub>

Specimens	Average wear after 8 hours, mg
Steel 30	171,3
Enamel No. 401	34,1

As can be seen from Table 11, the solubility of steel 30 in a sulfuric-acid solution (at a concentration of 0.5% H<sub>2</sub>SO<sub>4</sub>) is five times greater than the solubility of enamel No. 401.

In order to study the wear of enamel and steel in time in an abrasive moistened with a sulfuric-acid solution, tests were carried out on the same specimens with the wear measured at equal intervals of time (8 hours). At the beginning of the tests specimens not in operation were used. The test conditions remained unchanged: quartz sand of composition No. 1 with a moisture content of 50% and a concentration of 0.5%  $H_2SO_4$  in the solution was used as the abrasive. Table 12 shows the results of the tests, while the graphs plotted in Fig. 5 show the time dependence of the wear of steel and enameled specimens in a sulfuric-acid solution.

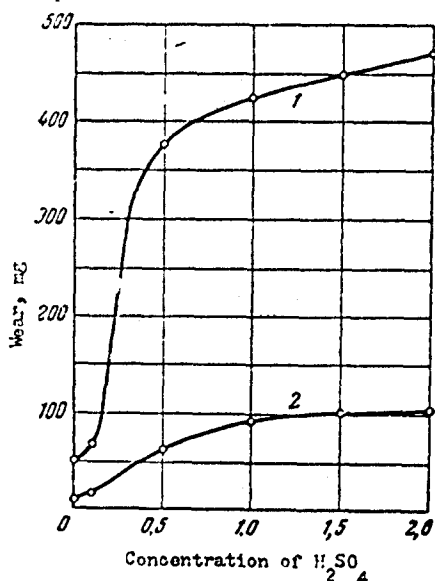

Fig. 4. Dependence of wear of specimens on concentration of sulfuric acid in solution.

1) steel 30 2) enamel No. 401

of enameled specimens decreases sharply.

Similar results were obtained in the case of the wear-resistance of enameled specimens subjected to wear by coal moistened with a sulfuric-acid solution. In the tests we used gas coal and anthracite, the grain size of which corresponded to a complete passage through the

TABLE 12

Wear of Specimens in Time in Quartz Sand Moistened with a Sulfuric-acid Solution

Specimens	Average wear in mg during the course of one 8-hour test			
	1 test	2 tests	3 tests	4 tests
Steel 30	377	313	287	247
Enamel No. 401	63,6	17,3	15,6	13,6

From the results of the tests it can be seen that the wear of steel specimens in time by an abrasive moistened with a sulfuric-acid solution decreases insignificantly, while that

sieve of 9 mm and to a complete nonpassage through the sieve of 3 mm. The moisture content of the coal was 50%, while the concentration of sulfuric acid in the solution was 0.5%.

Table 13 shows the results of tests for wear of enameled and steel specimens by coal moistened with a sulfuric-acid solution.

As was already mentioned, enamel No. 401 is a nonacid-resistant enamel, and in spite of this its wear-resistance in an aggressive acid medium is much higher than that of steel 30. Moreover, the wear-resistance of an enamel coating increases sharply with time. This is due to the properties of the silicates in the surface layer of the vitreous enamel. The rate of rupture of enamel varies in time, constantly slowing down as the protective film of silicic acid that forms increases in thickness.

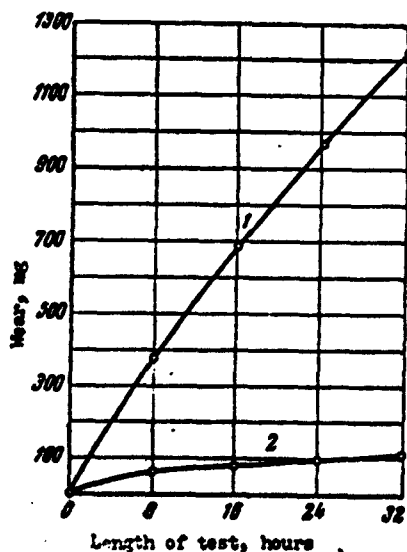

Fig. 5. The variation in the wear of specimens as a function of the test length in the case of an abrasive moistened with an acid solution

1) steel 30 2) enamel No. 401

TABLE 13

Wear of Specimens in Coal Moistened with a Sulfuric-acid Solution (0.5%  $H_2SO_4$ )

Coal	No. of composition	Average wear after 8 hours, mg	
		Enamel No. 401	Steel 30
Anthracite	5	26,6	259,1
Gas coal	6	15,2	112,0

#### Comparative Tests for Wear of Metal

##### Specimens in an Acid Medium

The steel specimens described above were subjected to tests for wear.

The tests were performed in quartz sand of composition No. 1,

50% of which consisted of a sulfuric-acid solution (0.5% H<sub>2</sub>SO<sub>4</sub>). The results of the tests are shown in Table 14.

TABLE 14

The Results of Tests for Wear of Metal Specimens in Quartz Sand Moistened with a Sulfuric-Acid Solution (0.5% H<sub>2</sub>SO<sub>4</sub>)

Material	Heat treatment	Hydrocarbon concentration, %	Micro-hardness, H <sub>μ</sub> , kg/mm <sup>2</sup>	Average wear after 8 hours, mg
Steel 20, rolled	In delivery state	0,21	378	316,4
Steel 20	Case-hardening, hardening and tempering	1,05	1100	585,1
Steel 30, rolled	In delivery state	0,29	224	377,0
Steel 30, chrome-plated		—	1045	212,2
Steel U10A	Hardening and tempering	0,97	1020	1223,5
Steel KhVG	Idem	1,02	1030	1394,8

The hardness of the material of the metal specimens in the given case has no effect on the wear-resistance. The somewhat higher wear-resistance of the chrome coating in comparison with the other metals is due not to its hardness, but to its comparatively greater acid-resistance. The greatest wear was noted in the case of the steels KhVG and U10A.

#### Laboratory Tests for Wear of Other Industrial Enamels

In order to determine the wear-resistance of enamel coatings on steel, we tested industrial sanitary-engineering and commercial enamels of the Artem Enameling Factory in Lugansk. Acid- and heat-resistant enamels were not tested, since the technology of the production of the Lugansk Enameling Factory is based on the use of enamels with a firing temperature no higher than 900°. Acid-resistant and, in

particular, heat-resistant enamels require a different technology and firing schedule.

Tests of coatings of industrial enamels on steel 30 were performed according to the above-described procedure in quartz sand of composition No. 1 moistened with a 0.5% sulfuric-acid solution (4000 g of sand and 2000 ml of sulfuric-acid solution).

The wear of enamel coatings in sand moistened with a 0.5% sulfuric-acid solution was 6-7 times greater than in moist sand.

These tests showed that green enamel No. 401 is entirely satisfactory for enameling parts operating in a neutral medium. However, for the coating of parts operating in an acid medium enamels that are more acid-resistant than the ones used at the Artem Factory must be used.

#### Industrial Tests

On the basis of the positive results of the laboratory studies of the wear-resistance of enamel coatings at the Artem Enameling Factory in Lugansk parts of various machines and mechanisms subjected to intense wear were enameled. Then industrial tests of these parts were performed.

Given below are the results of industrial tests performed on certain mining-machine components, in the manufacture of which the advantages of enameling are indisputable. Among such parts we may cite the impellers of a suspended sinking pump, the blades of mine ventilators, and chutes; the conditions of operation and wear are different for each of these parts.

a) Tests of enameled impellers of the PPN-50S suspended sinking pump.

Out of all the parts of a sinking pump it is the impellers that are subjected to the greatest wear. In a majority of cases this limits the operation of the pump as a whole and causes a sharp decrease in the output and the pressure head developed by the pump.

The life of the impellers in the pumping out of the pulp and extremely contaminated water amounts to 500-600 hours on the average. The intensity of the wear of the impellers, as that of other parts of the pump that come in contact with the liquids being pumped through, is affected mainly by the abrasive particles contained in the liquids and also by the chemical composition of the liquids. Under the conditions of the Donets coal basin underground waters are acidic. The impellers do not come into direct contact with other parts (with the exception of the shaft, on which they rest stationary). The wear of the impellers is accomplished by free abrasive particles contained in the liquids being pumped through.

The impellers of a PPN-50S suspended sinking pump were subjected to enameling. A brief technical characteristic of this pump is given below.

Output, m <sup>3</sup> /hr .....	50
Pressure of water column, mm H <sub>2</sub> O ..	250
Number of impellers .....	11
Diameter of impellers, mm .....	290
Capacity of electric motor, kw ...	75
Rpm .....	1470

The design of the enameled impellers, the technology of their casting, and their mechanical treatment differed in no way from those of nonenameled impellers. The material in both cases was modified

MSCh-28-48 cast iron.

The surfaces undergoing wear (the blades) were subjected to enameling. The thickness of the layer of enamel coating was 1.5 mm. The enameling was done by a dry method with enamel No. 51-52 on enamel base No. 1-2 according to the following scheme:

Cleaning on a sand-blasting apparatus  
↓  
Washing with hot water and cleaning with a steel brush and sand  
↓  
Coating with enamel base No. 1-2  
↓  
Drying of base coating at 100-120°  
↓  
Firing of base coating in a muffle furnace at 900°  
↓  
Coating with first layer of coating enamel No. 51-52 (impeller in a heated state)  
↓  
Firing of first layer of coating enamel at 900°  
↓  
Application of second layer of coating enamel No. 51-52  
↓  
Firing of second layer of coating enamel at 900°

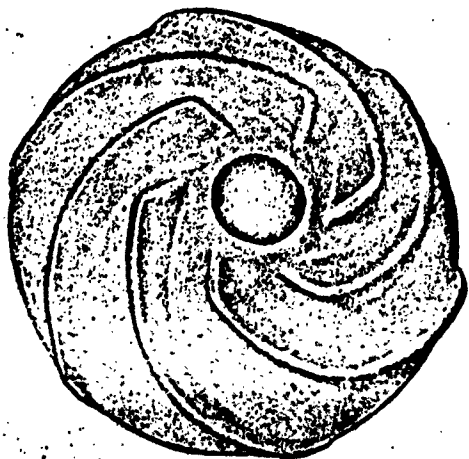

Fig. 6. Enameled impeller of PFN-50S mine pump.

After the enameling the impellers were subjected to additional static balancing by removing metal from the nonworking surface (no enamel was applied on this surface). Figure 6 shows an impeller after enameling.

Three pumps were subjected to industrial tests; in one pump all the impellers were enameled, while enameled and nonenameled impellers (every other one) were assembled in two pumps on one shaft. The

testing of the experimental pumps was carried out under actual industrial conditions. One of the experimental pumps was tested during the sinking of the shaft of the Krasnopol'ye Glubokaya mine, and two were tested during the sinking of the shaft of the Lutuginskaya Severnaya (Donbas) mine. The tests continued until the pumps went completely out of commission. As a result of a thorough inspection and measurements of the parts of the pumps it was established that the enameled layer on the impellers remained intact; on nonenameled impellers the surface on the ends of the blades was the most intensely worn. The wear on the ends of the blades of nonenameled impellers amounted to more than 4 mm; on enameled impellers the layer of enamel on the ends of the blades (as on the other surfaces) remained intact.

Thus enameled impellers completely retained their working capacity. According to rough calculations the useful life of impellers is approximately tripled by enameling.

b) Testing of enameled blades of mine ventilators

The operation of the axial ventilators of the mines in the Donbas and in other coal basins shows that the most intensely worn parts of these ventilators are the blades, the useful life of which varies from 6 to 18 months.

The increased wear of the blades is related to the pumping out of considerable masses of dust-laden, humidified, and gasified mine air. Wear and corrosion of the blades decrease their strength and considerably reduce the efficiency of the ventilator. The windswept blade surfaces most exposed to wear are the leading edges.

In accordance with the suggestion of Dongiprouglemash, by way of experiment we coated with enamel the blades of the series TsAGI-V two-stage, high-pressure axial ventilator, a brief characteristic of which

is given below.

Maximum output, m <sup>3</sup> /sec .....	156
Total pressure at maximum output, mm H <sub>2</sub> O ...	288
Power input, kw .....	670
Diameter of rotor, m .....	2.4
Rpm .....	750
Number of working stages .....	2
Number of blades on each stage .....	16

The blade covering is made of sheet steel 30 with a thickness of 2.5 mm. The windswept surfaces of the blades not in direct contact with the other parts of the ventilator were subjected to enameling. The enameling was done with enamel No. 401 according to the following scheme:

Cleaning of blade surfaces on a sand-blasting apparatus  
↓  
Coating with enamel base No. 27/35/18  
↓  
Drying of base coating at 80-100°  
↓  
Firing of base coating in a muffle furnace at 900°  
↓  
Coating with first layer of coating enamel No. 401  
↓  
Drying of first layer of coating enamel at 150-200°  
↓  
Firing of first layer of coating enamel at 850-880°  
↓  
Application of second layer of coating enamel No. 401  
↓  
Drying of second layer of coating enamel at 150-200°  
↓  
Firing of second layer of coating enamel at 850-880°

The thickness of the layer of the enamel coating of the blades was 0.7-1.5 mm. Figure 7 shows a ventilator blade after enameling.

In order to obtain comparative data concerning the wear of ordinary and enameled blades, 12 enameled and 4 ordinary blades were installed on each stage (one ordinary blade for every three enameled blades).

Before installing each pair of diametrically opposite blades they were carefully prepared by weight. On the basis of the regime of operation of the ventilator used in summer, all the blades were installed at an angle of  $35^{\circ}$  to the axis of the rotor. The rotor underwent static and dynamic balancing.

Industrial tests of the ventilator were carried out in mine No. 6-6 bis (Donbas), which was super-category with respect to gas and dangerous with respect to dust.

Measurements of the dust content of the air in the ventilator channel showed that the dust content of the air stream passing through the ventilator was 57 times greater than the normal dust content of mine air; the dust concentration in the air amounted to  $570 \text{ mg/m}^3$ ; according to calculations, an average of up to 3.7 tons of coal dust passed through the ventilator each day.

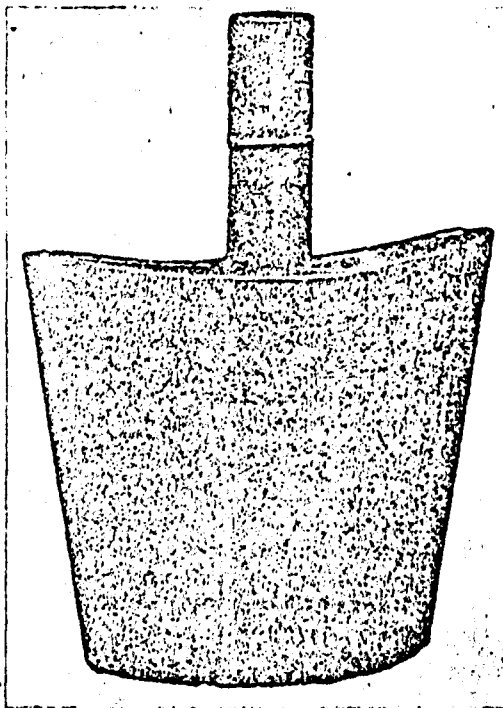

Fig. 7. Enameled blade of the TsAGI-V ventilator.

The air stream, passing through the ventilator channel at a speed of 15.5 m/sec, carried, along with coal dust and culm, the water filtering through the walls of the channel and arrived in the ventilator considerably humidified. The relative humidity of the air in the ventilator channel was 59%. The industrial tests of the ventilator lasted for 118 days, which amounted to 2843 hours. A careful inspection of the ventilator and the measurements made showed the following.

1. The nature of the wear of all the blades was the same; the leading edges received the most wear, particularly

at the ends.

2. Ordinary and enameled blades installed on the first-stage impeller were subjected to greater wear than the blades of the second-stage impeller.

3. On ordinary nonenameled blades of the first-stage impeller wear along the leading edge was noted in the form of a strip, the width of which varied from 8 to 10 mm at the base of the leading edge to 12 to 15 mm at the end of this edge. The greatest depth of wear of the blade covering (1.8-2 mm) occurs at the end of the leading edge of the blade.

In the case of enameled blades installed on the same first-stage impeller the enamel layer wore through on the leading edge over a strip 8-10 mm wide at the base and 12-15 mm at the end of the leading edge. The blade covering remained intact under the enamel layer and showed only insignificant signs of wear.

4. On enameled blades of the second-stage impeller the enamel layer was worn through over  $\frac{3}{4}$  of the length of the leading edge. The blade covering under the enamel layer was not entirely worn through.

5. On none of the blades did we detect absence of the enamel layer, swelling, cracking, etc.

6. According to tentative calculations, the useful life of enameled ventilator blades in operation in extremely dust-laden and humid air in comparison with ordinary blades is increased by approximately 4 months of continuous operation, i.e., it is doubled.

### c) Tests of enameled chutes

The transporting of coal in mine faces working seams of gentle slope (from 0 to 25°) is accomplished by means of different types of

conveyors. In the case of more steeply sloping seams in mine faces, instead of conveyor transport, gravity flow of the coal over metal sheets or through so-called dead-end chutes (conveyor sections) is used. Gravity flow of the coal depends on many factors: the angle of inclination, the grade of the coal, its fractional composition, moisture content, dust content, surface roughness, etc.

Until recently chutes made by stamping out of MST-3 sheet steel were widely used in our coal mines.

During the course of operation the chutes are worn away intensely by the coal being transported through them and in the overwhelming majority of cases are subjected to considerable corrosion (as a result of water seepage through the mine faces, dripping of water from the roof, etc.). The difficult conditions of operation of the chutes greatly limit their useful life. In mines of the Donbas the useful life of chutes amounts, on the average, to 6 months of operation. During this period approximately 39 thousand tons of coal are transported through the chutes for every 100 meters of mine face. The Donbas alone uses daily 50-60 thousand chutes (the average weight of a chute is 45 kg).

No less important is the problem of creating better conditions for the sliding of the coal being transported in the chutes. A decrease in the friction coefficient of the coal over the working surface of the chutes would make it possible to improve their operational qualities and to use gravity-flow transporting of coal even in seams with a gentle slope. This would allow us to cut down the use of more expensive and less reliable conveyors.

The enameling of the experimental part of the chutes was done according to a suggestion of the Planning and Designing Experimental

Institute of Complex Mechanization of the Donbas Mines (Dongiprougle-mash). The working surfaces of ordinary chutes of the SKR-11 mine scraper conveyor were enameled. These surfaces were made out of MST-3 sheet steel 3 mm thick by the Kharkov factory "Svet shakhtera." Ordinary enamels used in sanitary-engineering components were used for the enameling of the experimental part of the chutes: white enamel No. 112-232-201B, brown enamel No. 403, and green enamel No. 401. The enameling was done according to the same scheme used for the ventilator blades. The total thickness of the enamel coating of the chutes was 0.7-1.5 mm.

Industrial tests of the enameled chutes were performed under various mining-geology conditions of working gently sloping seams with angles of inclinations ranging from  $11^{\circ}$  and up for the case of gravity-flow transporting of anthracite (Donets mine No. 67) and smoky coal (the Lenin Donets mine).

The extraction of anthracite in mine faces was done with the aid of cutting machines with subsequent demolition of the cut face and manual loading of the coal onto the chutes. The extraction and loading of smoky coal was done with a combine. The experimental enameled chutes operated in the presence of water dripping from the roof and were subjected periodically to the action of a shock wave during the demolition of the face and to intensified wear by the coal. However, even under these conditions of operation the tests showed that enameled chutes possess valuable properties and have the following advantages over ordinary nonenameled chutes used for gravity transportation of coal.

1. Gravity-flow transporting of coal through enameled chutes occurs at a smaller angle of inclination of the chutes. Thus, gravity

flow of unsorted anthracite (ARSh) through enameled chutes begins at an angle of inclination of the seam of  $11^{\circ}$ , while in the case of ordinary chutes gravity flow of this coal is possible only at an angle of inclination of  $16^{\circ}$ . Gravity flow of unsorted smoky coal (brand G) through enameled chutes begins at an angle of inclination of the seam of  $18^{\circ}$ , while in the case of ordinary chutes gravity flow begins only at an angle of  $24^{\circ}$ .

2. The enamel coating of the chutes preserves them from corrosion, as a result of which they can be used successfully under conditions of water seepage, when ordinary chutes quickly undergo corrosion and do not ensure the gravity flow of coal.

Before the installation of enameled chutes in mine No. 67 the anthracite was transported through ordinary chutes with the aid of workers pushing it through. The installation of enameled chutes in the mine faces ensured gravity flow of the coal. Instead of four pushers, the chute rigging was manned by only one auxiliary worker monitoring the transfer of the coal onto the drift conveyor. After three months of testing the enameled chutes the savings in just the wages of all the workers (in two mine faces) eliminated from the mine amounted to more than 22 thousand roubles. The useful life of ordinary chutes in this mine was 2-3 weeks. The efficient operation of the enameled chutes improved the operation of the mine. The average daily output of coal increased by more than 50%, while the labor productivity of cutting and loading miners increased by 30%.

3. The enamel coating of the chutes did not make it harder to dismantle, transport, and reassemble them. Nor did it change the degree of reliability and the failure-free operation of ordinary chutes.

4. Damage to the enamel was observed as a result of the false roof caving in on the chutes and as a result of the impact caused by pieces of rock falling during demolition operations. In such cases it is necessary to cover the chutes with rock beforehand, in order to protect the enamel layer from damage.

5. The most wear-resistant chutes were found to be those coated with enamel No. 401.

In addition, the tests showed that SKR-11 enamel chutes have structural defects. SKR-11 chutes have a profile with a hollowed-out center strip and projecting edges on the sides. The enamel coating on these edges wears out quickly. The butt-joining of the chutes in the SKR-11 conveyors impairs the conditions of gravity flow of the coal, since a gap clogged up with culm forms in the joints.

Dongiprouglemash developed the design of the RE special enameled chutes. These RE chutes are somewhat shortened, weigh less, and have an improved profile and method of joining. The enameling of these chutes was done with enamel No. 401. Twelve hundred such chutes are in operation in the mines of the Lugansk province alone. Many mine faces in which chain conveyors or dead-end chutes with forced pushing of the coal were formerly used have been converted to gravity-flow transporting of the coal.

The use of enameled chutes is especially effective under conditions of water seepage through the mine faces with increased moisture of the coal, when ordinary chutes are subjected to intense corrosion and become unfit for gravity-flow transporting of the coal.

The experience of the operation of the RE enameled chutes showed that the wear of the enamel coating of the chutes after three months of operation under the most adverse conditions does not exceed 6-7%

of their working surface; such wear has no effect on the gravity flow of coal. These chutes simplified and accelerated the transporting of rigging, eliminated the need for manpower formerly engaged in transporting, increased operational safety, and produced an average monthly savings of 13.5 thousand roubles per hundred meters of mine face. The annual savings resulting from conversion to gravity-flow transporting of coal through RE enameled chutes in 140 mine faces of the mines of the Lugansk economic region amounted to approximately 17 million roubles.

The Artem Enameling Factory in Lugansk is engaged in work on re-enameling of worn RE chutes (restoration), which will considerably lengthen the useful life of the billets of the chutes and will yield an additional savings of tens of millions of roubles.

### Conclusions

The studies give us reason to draw the following conclusions.

1. The concept of periods of wear (initial increased wear and normal) can be used in its entirety for the case of wear of enamel coatings by a free abrasive. The resistance of enamel coatings to abrasive wear may be regarded as the result of two properties of the coating: the resistance to wear of the surface layer and the resistance to rupture of the structure of the underlying enamel.
2. The wear of the enamel coatings increases with increasing grain size of the abrasive.
3. The degree of moisture of the abrasive, as is true for moisture in general, has no appreciable effect on the wear-resistance of enamel coatings. In comparison with carbon steels, enamel coatings widely resist wear by a moist abrasive, but poorly resist wear by dry quartz sand.

4. The wear of the nonacid-resistant enamels studied increases with an increase in the concentration of sulfuric acid in the abrasive medium. The rate of wear of enamel coatings in an abrasive medium containing a sulfuric-acid solution sharply decreases in time. The nonacid-resistant enamels studied, when subjected to wear in an abrasive medium containing a sulfuric-acid solution, possess considerably greater wear-resistance than steels and chrome coating. It is to be hoped that acid-resistant enamels will be more wear-resistant.

5. The resistance of steels to wear by a dry abrasive increases with an increase in their hardness.

6. Enameling is an effective means of increasing the wear-resistance of parts operating under conditions of wear by a moist abrasive, especially in the presence of acids.

7. Enameling of parts, in addition to increasing their useful life, leads in a number of cases to an improvement in the operational characteristics of the machine.

8. In the majority of cases enameling of parts does not require any change in their design; at most a few insignificant structural changes are sometimes necessary.

Parts intended for enameling are made out of low-carbon steels and gray iron.

9. Owing to the low cost of the enamels and the insignificant expense involved in enameling, the use of enamel coating of machine parts is economically expedient. Moreover, in many cases enamel coatings can be restored by re-enameling. Coating with enamel is a simple operation and can easily be mastered by any machine-building plant.

10. It is advisable to carry out further work in the study of the wear-resistance of enamel coatings; as a result of this work the range of application of enamel coatings in machine construction can be expanded considerably.

#### REFERENCES

1. A. Petzold. Enamel. Berlin, 1955.
2. V. S. Lomakin. A Study of the Wear of the Bushings and Rings of Sludge Pumps. Friction and Wear in Machines, Symposium Publishing House of the Academy of Sciences of the USSR, 1956.

127

**DISTRIBUTION LIST**

DEPARTMENT OF DEFENSE	Nr. Copies	MAJOR AIR COMMANDS	Nr. Copies
		AFSC	
		SCFDD	1
		ASTIA	25
HEADQUARTERS USAF		TDBTL	5
		TDEDP	5
AFCIN-3D2	1	AEDC (AEY)	1
ARL (ARB)	1		
<b>OTHER AGENCIES</b>			
CIA	1		
NSA	6		
DIA	9		
AID	2		
DTS	2		
AEC	2		
PWS	1		
NASA	1		
ARMY	3		
NAVY	3		
PGE	12		
RAND	1		
NAFEC	1		