

21600

63-3-2

AFRL-63-225

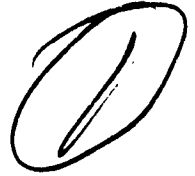

AD NO. 401058

ASTIA FILE COPY

Spectroscopic Studies with Ion Beams

R. H. Hughes, J. L. Philpot, J. G. Dodd, and S. Lin

Department of Physics
University of Arkansas
Fayetteville, Arkansas

Technical Report
Contract AF 19 (604) - 4966

September 1962
Project 7661
Task 76614

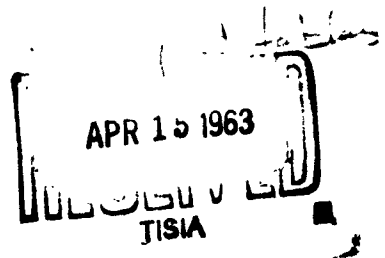

Geophysics Research Directorate
Air Force Cambridge Research Laboratories
Office of Aerospace Research
United States Air Force
Bedford, Massachusetts

#460

Code 73700

**Best
Available
Copy**

21600
13 AFRL-63-225

6
8

Spectroscopic Studies with Ion Beams

6-11-65

R. H. Hughes, J. L. Philpot, J. G. Dodd, and S. Lin

Department of Physics
University of Arkansas
Fayetteville, Arkansas

7
12 Technical Report
Contract AF 19 (604) - 4966

9
8 September 1962
Project 7661
Task 76614

10 23p incl. illus tables,
19 refs.

11 WA

Geophysics Research Directorate
Air Force Cambridge Research Laboratories
Office of Aerospace Research
United States Air Force
Bedford, Massachusetts

1780

Abstract

A spectroscopic study of ion-atom and ion-molecule collision processes ^{is presented.} ~~has~~ been undertaken. Absolute cross sections for excitation of principal visible features are presented in this report for proton impact on He, H^{sub 2} and N^{sub 2} in the proton-energy range from about 10 kev to 130 kev. Optical radiation is observed at an angle to the beam, which allows measurement of charge-changing cross sections for electron capture into certain excited states of hydrogen. Reprints of published studies of 200-kev proton impact on He and N^{sub 2} are included together with a reprints of a note describing some spectral features of 200 kev H^{sub 2} and 130 -200 kev H^{sub 2} impact on H^{sub 2} and He. ~~Included also are~~ ^{sub 2} calculated minimum-energy defects for several reactions ^{sub 2 (+)} ~~are also included.~~ ^{sub 3 (+)}

Apparatus

A positive-ion accelerator was built to accelerate ions through a maximum potential difference of about 150 KV for the purpose of studying the spectra induced by ion impact on gases. In practice we find that operation is satisfactory below 130 KV. Some studies have been made using as low as 5-kev beams of H⁺ but the currents at these energies are small, which make such studies difficult. The low-energy limit will be lowered for future studies simply by reducing the length of the glass-aluminum beam tube (presently 2 feet). The accelerator uses an ORTEC r-f ion source. The beam is magnetically analyzed as it is bent through 30° into the collision chamber. Fig. 1 shows the details of the collision chamber. Not shown is a liquid-air trap at the end of the collision chamber installed to remove condensible vapors from the collision region.

A JaCo 500 mm Ebert scanning spectrometer has been calibrated for use in

Fig. 1 Collision chamber - (1) gas inlet, (2) differential pumping outlet, (3) McLeod gauge, (4) view port, (5) electron repeller, imbedded in Lucite which insulates the collision chamber, (6) collimating apertures (1/16" holes), (7) Pirani gauge.

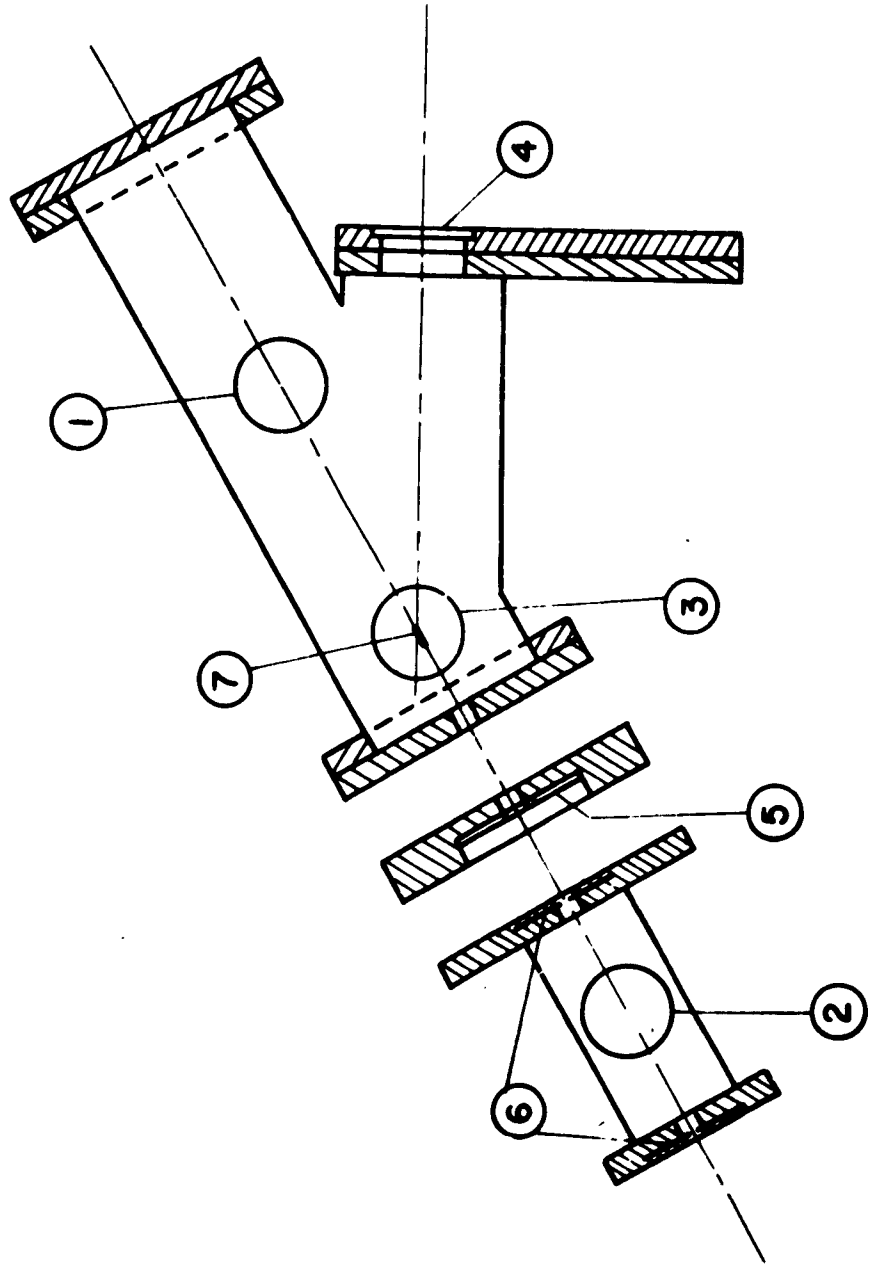

the 3800A to 6600A spectral range. Calibration procedure has previously been described.¹ A JaCo 500 mm Seya-Namoika vacuum spectrometer has been obtained for Lyman alpha studies. Attempts were made to measure the Lyman alpha radiation with the vacuum spectrometer, but the system failed to detect the radiation. A new optical system is being designed around the vacuum spectrometer to increase the optical efficiency.

Pressure measurements are made with a McLeod gauge while a Pirani gauge is used to monitor the pressure. Most data are obtained in the pressure range of 1-10 μ Hg. Helium and hydrogen are let into the collision chamber via a liquid-air-cooled charcoal trap and a heated palladium leak respectively. A cold trap is used to condense out moisture in all cases. The beam is observed at a 30 $^{\circ}$ angle which permits the observation of the Doppler shifted hydrogen emission from fast hydrogen atoms. This makes possible differentiation between radiation from fast hydrogen atoms and radiation from stationary hydrogen atoms in the collision chamber.

Study I - Spectra Induced by H⁺ Impact on N₂

A. The N₂⁺ First Negative Band System

Cross sections for exciting four members of v' = 0 progression in the B² Σ \rightarrow X² Σ transition are displayed in Fig. 2. These emissions were linear with pressure and current below 5 μ pressure and above 20 kev. Linearity with pressure below 20 kev was not checked; thus our confidence in the low-energy region is somewhat limited. This latter statement applies to all the measurements included in this report. All measurements involving N₂ were made in the 1 μ - 5 μ pressure range.

Our definition of the cross section σ follows from the equation: $n = \sigma \rho F$

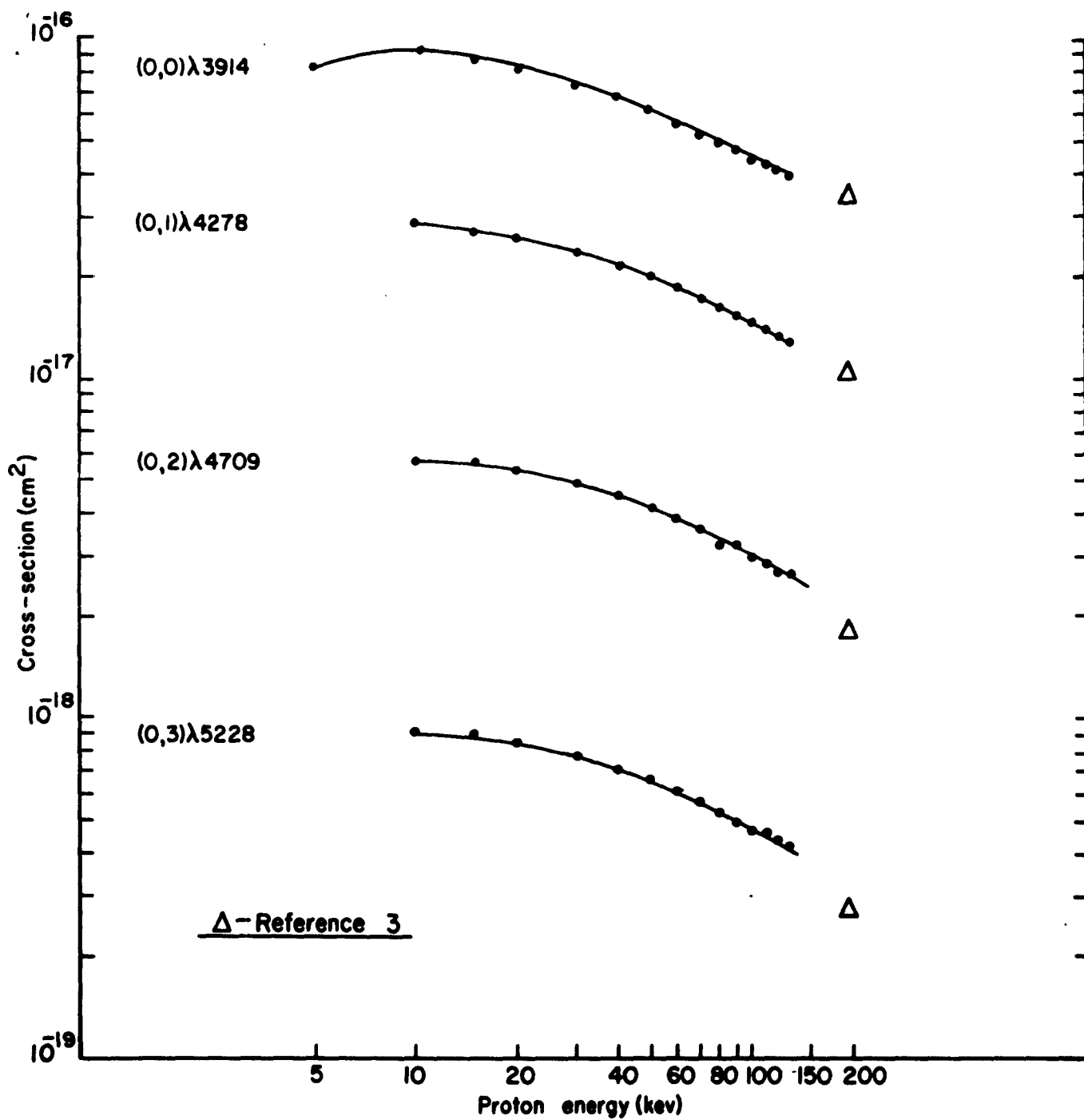

FIG. 2. Cross sections for the v=0 progression emissions in the N₂⁺ first negative system

where n is the number of photons emitted from a cubic centimeter, ρ is the molecular density in the chamber, and F is the proton flux.

Our results for the $(0, 0)$ $\lambda 3914$ band agrees well with Sheridan et al² where overlap occurs. Their measurements are for 30 kev and less. Our results appear to be about 10 per cent lower. Our previous results³ at 200 kev seem somewhat low compared with an extrapolation of these curves to 200 kev, but is in acceptable agreement. The cross sections displayed were determined with a spectral slit width of 25A, thus the cross sections represent the emission in this wave length interval. Exceptions are the results for the $(1, 1)$ $\lambda 3884$ and $(1, 2)$ $\lambda 4236$ emissions of the N_2^+ first negative band system which are included in Fig. 3. Higher resolution was required to resolve these bands, and thus determinations were made with a smaller slit width.

Fig. 3 displays our results for the $v' = 1$ progression in the N_2^+ first negative band system. The accuracy of the results for this progression is limited by the resolution problems for $\lambda 4236$ and $\lambda 3884$ as well as for the $(1, 0)$ $\lambda 3582$ band. In the $\lambda 3582$ band there is always the possibility that the unresolved N_2 second positive band at $\lambda 3577A$ may affect the results. This band gives the $\lambda 3582$ band the appearance of pressure dependency since it is excited by a neutral component in the beam at low energies and by secondary electrons at the high energies. We hope that our measurements are valid since we operated at quite low pressure.

Neglecting cascade effects, population cross sections for the $v = 0$ and $v = 1$ levels of the $B^2\Sigma$ state were determined as a function of proton energy simply by summing the cross section for the $v' = 0$ and $v' = 1$ progressions respectively. These results are displayed in Fig. 4. Relative transition probabilities could be determined for various bands and are listed in Table I.

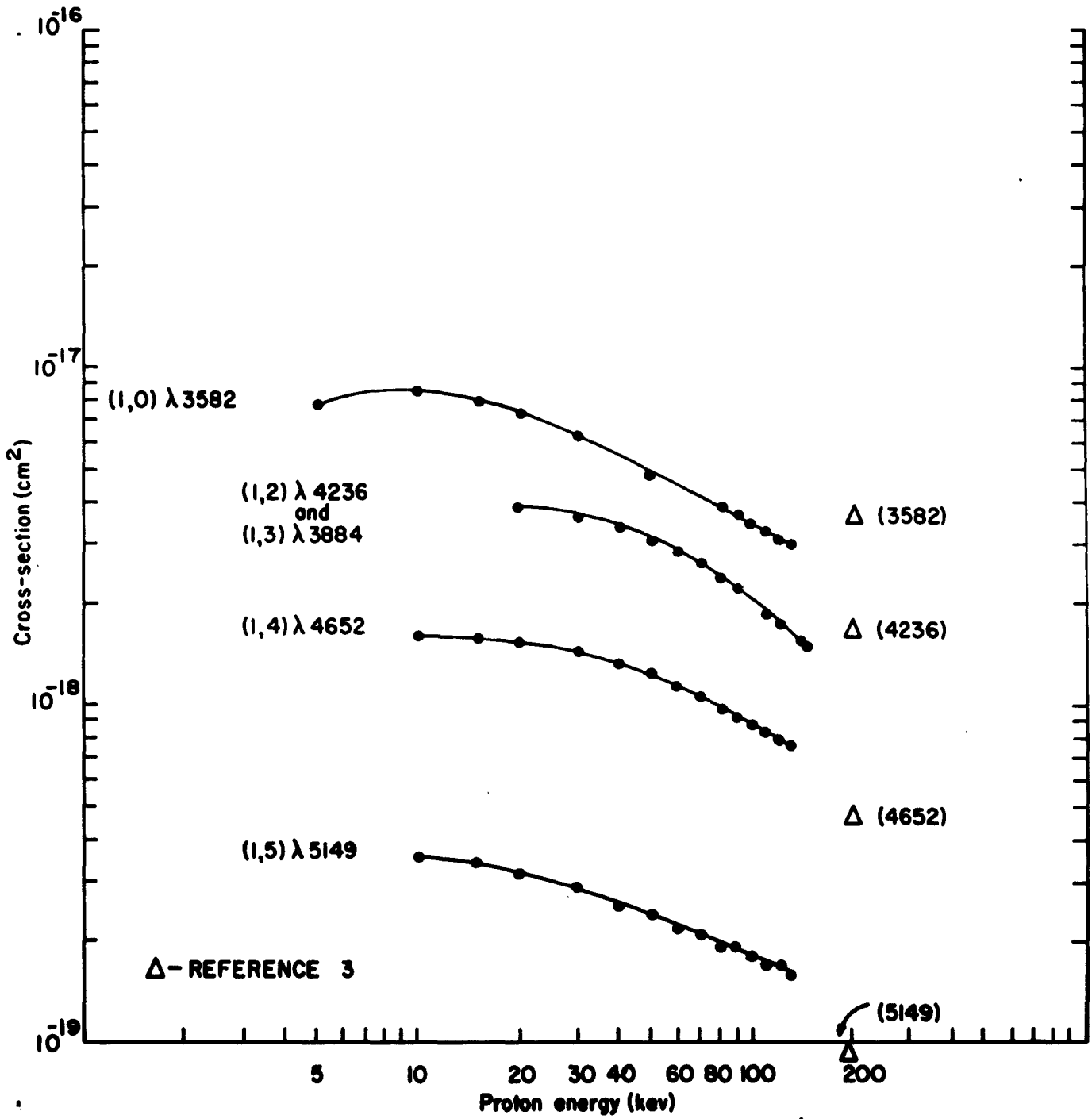

FIG. 3. Cross sections for the $v' = 1$ progression in the N_2^+ first negative system

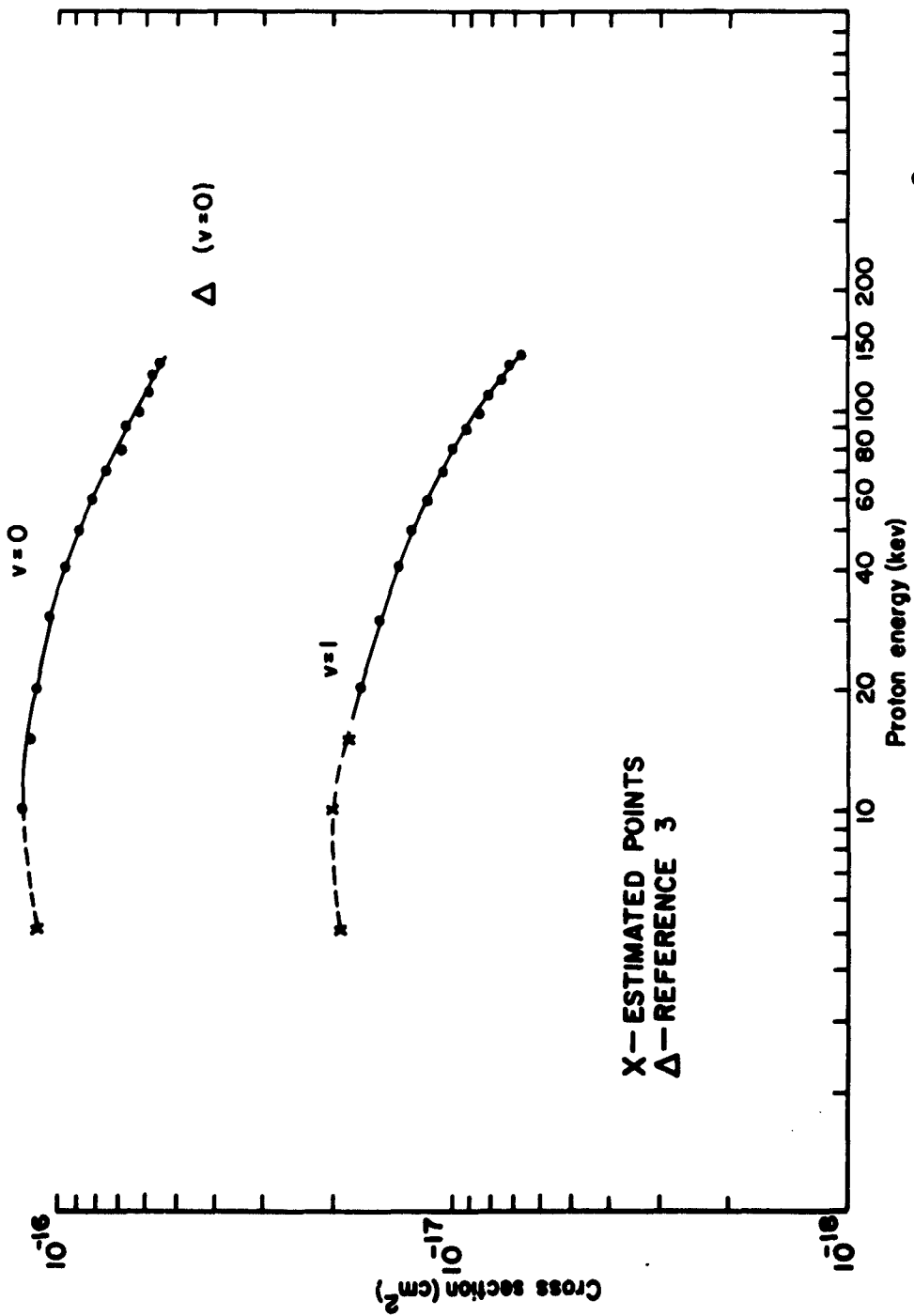

FIG. 4. Population cross-sections for the v=0 and v=1 levels of the B ²Σ state of N₂

Table I - Transition probabilities associated with the
 N_2^+ first negative band system

Transition	A	B	C
0-0	.715	.69	.67
0-1	.229	.26	.23
0-2	.048	.04	.08
0-3	.007 ₅		
1-0	.40	.23	.28
1-1	.24 ₅	.27	.25
1-2	.23 ₅	.38	.26
1-3	.10	.11	.14
1-4	.02	.01	.04

A Measured by this experiment (fast H^+ impact)

B Measured by Herzberg⁴ (1929)

C Calculated by Pillow⁵

Also listed are Herzberg's measured transition probabilities⁴ as well as Pillow's calculated transition probabilities⁵. The transition probabilities as measured by this experiment were very consistent throughout the energy range for the $v' = 0$ progression. The reproducibility gives us high confidence in the stated values.

Stewart⁶ has recently measured N_2^+ first negative excitation by electron impact. He quotes the relative band intensity of (0, 0), (0, 1) and (0, 2) to be 1.0: 0.39: 0.10 which he compared to Bates' theoretical values⁷ of 1.0: 0.31: 0.072. Bates' article is not available to us to compare transition probabilities, but our relative band intensities are 1.0:0.32:0.067 which are in excellent agreement with Bates.

The probabilities measured for the $v' = 1$ progression, however, were not particularly consistent, and reproducibility from energy to energy varied as much as 7 per cent. We attribute this to the uncertainties in the $\lambda 3884$ and $\lambda 4236$ bands and possibly in the $\lambda 3582$ band. The discrepancy, however, is quite large between our transition probabilities and Herzberg's values for the $v' = 1$ progression.

The N_2^+ excitation is interesting. At the lower energies the dominant mechanism for the production of N_2^+ ions is charge transfer, while at the higher energies straight ionization is dominant. We normalized the measurements of Il'in et al⁸ for the production of N_2^+ ions to the charge-transfer cross-section measurements listed in Allison's review article⁹ at the lower energies (5 - 15 kev). Using these two sets of data we then determined the fraction of N_2^+ ions that are formed by the processes of ionization and charge transfer. The results are shown in Fig. 5. (There is considerable uncertainty in reading value from the small graphs in Reference 8.)

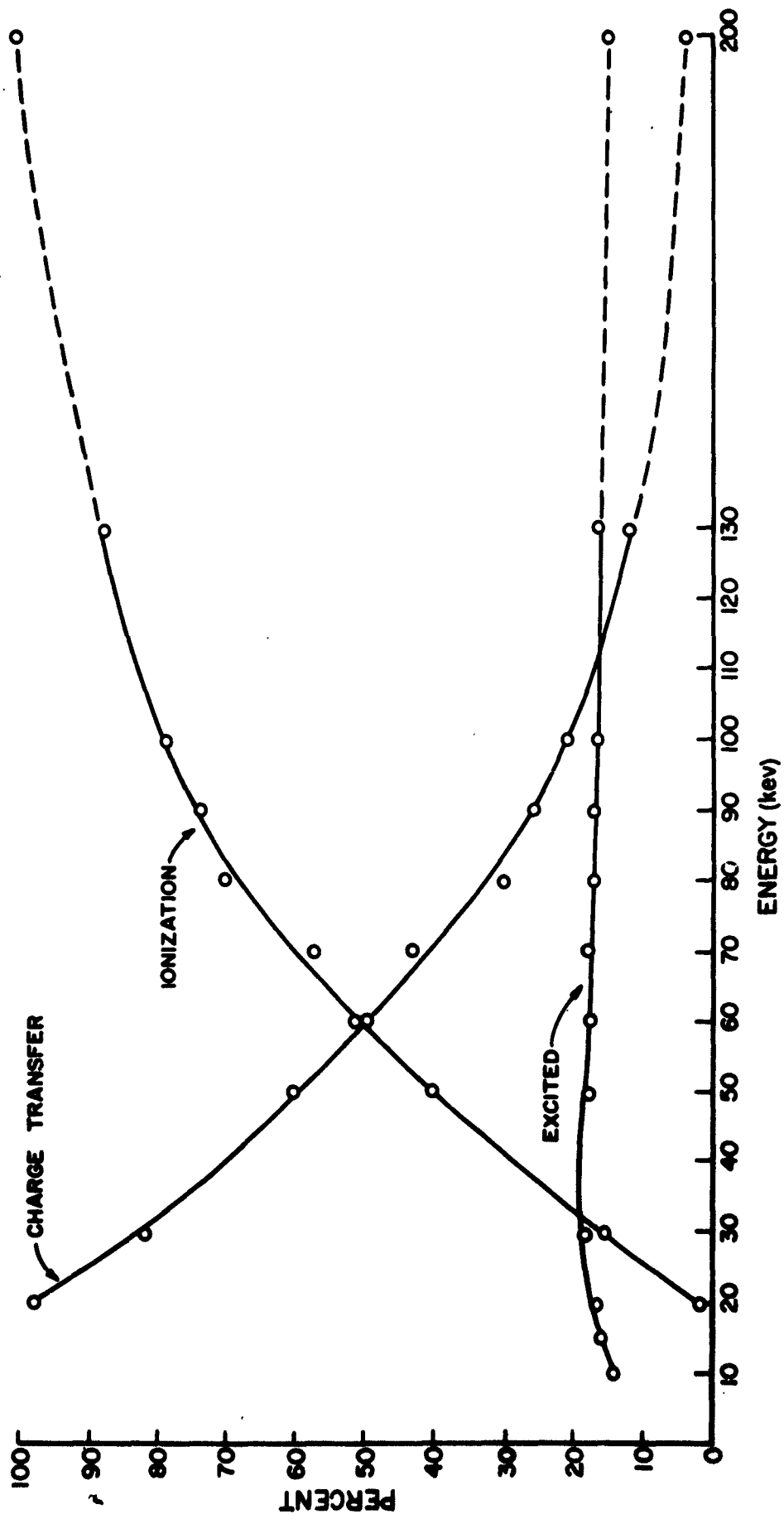

Fig. 5 Fraction of N_2^+ produced by charge transfer, ionization, and fraction of N_2^+ excited to the $B \ ^3\Sigma_u^+$ electronic level by both processes.

We then assumed that our excitation cross section for the $v = 0$ and $v = 1$ states of $B^2\Sigma$ level represented 95 per cent of the excitation of the $B^2\Sigma$ level and plotted the fraction of the N_2^+ ions that are excited to the $B^2\Sigma$ level by both ionization and charge transfer. Much to our surprise the excited fraction remained at a fairly large constant value of between 15 per cent and 20 per cent. One might have expected a somewhat smaller value at the higher energies where the N_2^+ excitation might approach the N_2^+ excitation produced by an electron at the same velocity. Stewart⁶ has measured N_2^+ excitation by electron impact. He finds that the excitation of the $B^2\Sigma v = 0$ level maximizes at about 100 volts with a cross section of $9.5 \times 10^{-18} \text{ cm}^2$. If we assume that 80 per cent of total ionization cross section for electron impact represents the production of N_2^+ ions, then the excitation of this level represents at most 4 per cent of the N_2^+ ions formed. For 200-kev proton (velocity equivalent to a 100-ev electron) impact, about 96 per cent of the N_2^+ ions are formed through straight ionization, and yet we have previously obtained the large cross sections of about $4.3 \times 10^{-17} \text{ cm}^2$ for exciting the $B^2\Sigma v = 0$ level. Charge transfer is not sufficient to explain the discrepancy, since the total transfer cross section is only $1.5 \times 10^{-17} \text{ cm}^2$ at 200 kev. We conclude therefore that proton excitation does not seem the same as electron excitation even where charge transfer is not a factor.

B. H_α and H_β Emissions

Cross sections for H_α and H_β emissions were measured. The results are displayed in Fig. 6. The measurements below 20 kev may be too high, in particular H_α . We single out H_α for doubt because we were unable to make this emission peak at the lower energies. H_β seems to peak at about 10 kev. In fact our H_β measurements, where they overlap, agree well with Sheridan et al².

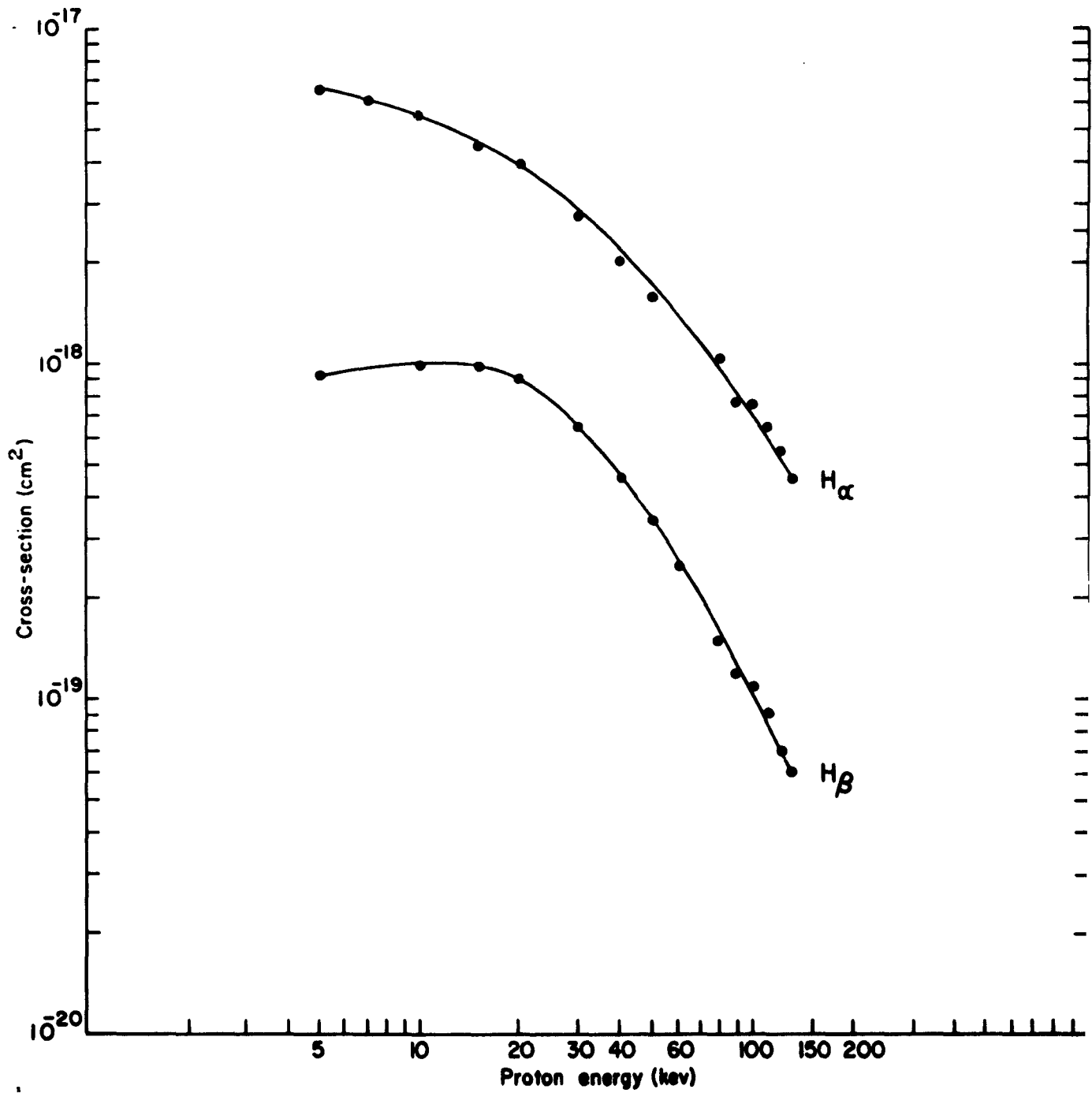

FIG. 6. H_α and H_β emission from H⁺ impact on N₂

It has been our experience that H_{α} and H_{β} tend to peak at about the same energy. We suspect that either our pressure is too high ($\sim 1\mu$) for this low energy (and we are observing H_{α} photons from beam neutrals formed through charge exchange and excited by a second collision) or we have background problems that we are unaware of. With our present system we suffer too much loss in beam current at the lower energies to operate at a safer lower pressure. This situation will be remedied in the future.

The fraction of the total charge transfer resulting in H_{α} and H_{β} emission was calculated. These fractions are shown in Fig. 7. The total charge-transfer cross sections were again taken from Allison's article.⁹ Fig. 7 is an indication of the efficiency of the charge-transfer process in producing H_{α} and H_{β} photons.

Charge transfer into excited states of hydrogen could be estimated from the H_{α} and H_{β} measurements. The factor required to change the line cross section to level cross section can be derived easily (neglecting cascade). For example, consider excitation to the $n = 3$ level. Let $\frac{dN(3s)}{dt} = \sigma(3s)\rho F$ be the rate at which the 3s level is being populated by proton impacts where $N(3s)$ is the number of atoms being placed in the 3s level per cm^3 , $\sigma(3s)$ is the level cross section, ρ the target gas density and F is the proton flux. Similar equations will hold for the 3p and 3d levels. Thus $\sigma(n = 3) = \sigma(3s) + \sigma(3p) + \sigma(3d)$.

The rate at which the 3s level is depopulated by radiative processes is $\frac{dN(3s)}{dt} = \frac{N(3s)}{T_{3s}}$ where T_{3s} is the mean radiative lifetime of the 3s state. In equilibrium we have then that $N(3s) = T_{3s}\sigma(3s)\rho F$ with similar equations holding for the 3p and 3d levels. The rate at which H_{α} photons are being emitted, $n(H_{\alpha})$, is $n(H_{\alpha}) = \sigma(H_{\alpha})\rho F = N(3s)A(3s \rightarrow 2p) + N(3p)A(3p \rightarrow 2s) + N(3d)A(3d \rightarrow 2p)$.

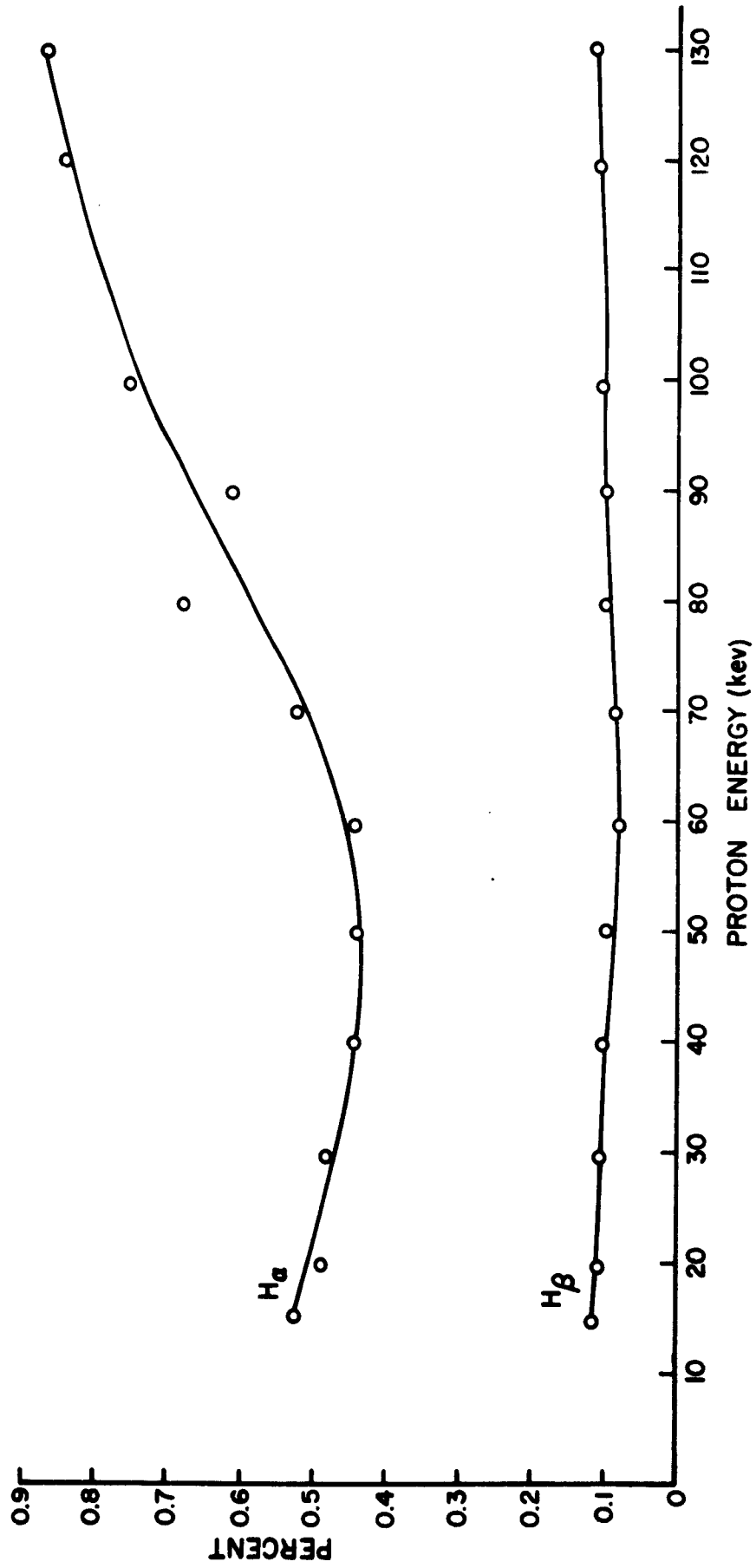

Fig. 7. Fraction of total charge transfer resulting in H α and H β emission by H $^+$ impact on N $_2$

Substituting we find

$$(1) \quad \sigma(n = 3) = \sigma(H_{\alpha}) \left[\frac{1 + R_1 + R_2}{1 + R_1 T_{3p} A(3p \rightarrow 2s) + R_2 T_{3d} A(3d \rightarrow 2p)} \right]$$

where $R_1 = \frac{\sigma(3p)}{\sigma(3s)}$ and $R_2 = \frac{\sigma(3d)}{\sigma(3s)}$.

For $n = 4$ we have

$$(2) \quad \sigma(n = 4) = \sigma(H_{\beta}) \left[\frac{1 + R_3 + R_4}{T_{4s} A(4s \rightarrow 2p) + R_3 T_{4p} A(4p \rightarrow 2s) + R_4 T_{4d} A(4d \rightarrow 2p)} \right]$$

where $R_3 = \frac{\sigma(4p)}{\sigma(4s)}$ and $R_4 = \frac{\sigma(4d)}{\sigma(4s)}$.

We neglect $\sigma(4f)$ which is likely to be small.

An equation similar to (2) was published in Reference 3, which unfortunately is in error.

The cross-section ratios must be estimated from theory. We appeal to the calculations of Bates and Dalgarno¹⁰ on the charge-transfer reaction of proton impact on atomic hydrogen. We could have also chosen Mapleton's calculation¹¹ on helium to determine this factor. At high energies (> 100 kev) we found it made little difference which calculations we used. The maximum difference in the multiplying factors in the two cases is only 15 per cent for energies greater than 20 kev, but because Mapleton's calculations do not predict maxima in the cross-section vs energy curve we chose the hydrogen problem as perhaps a better analogy. The results of this procedure are shown in Fig. 8.

C. N^+ Emissions

Fig. 9 shows the excitation of the $\lambda 5005A$ and $\lambda 5680A$ emissions of N^+ vs energy. These emissions peak at about 40 kev, which is indicative of the large energy defect compared with the other reactions studied.

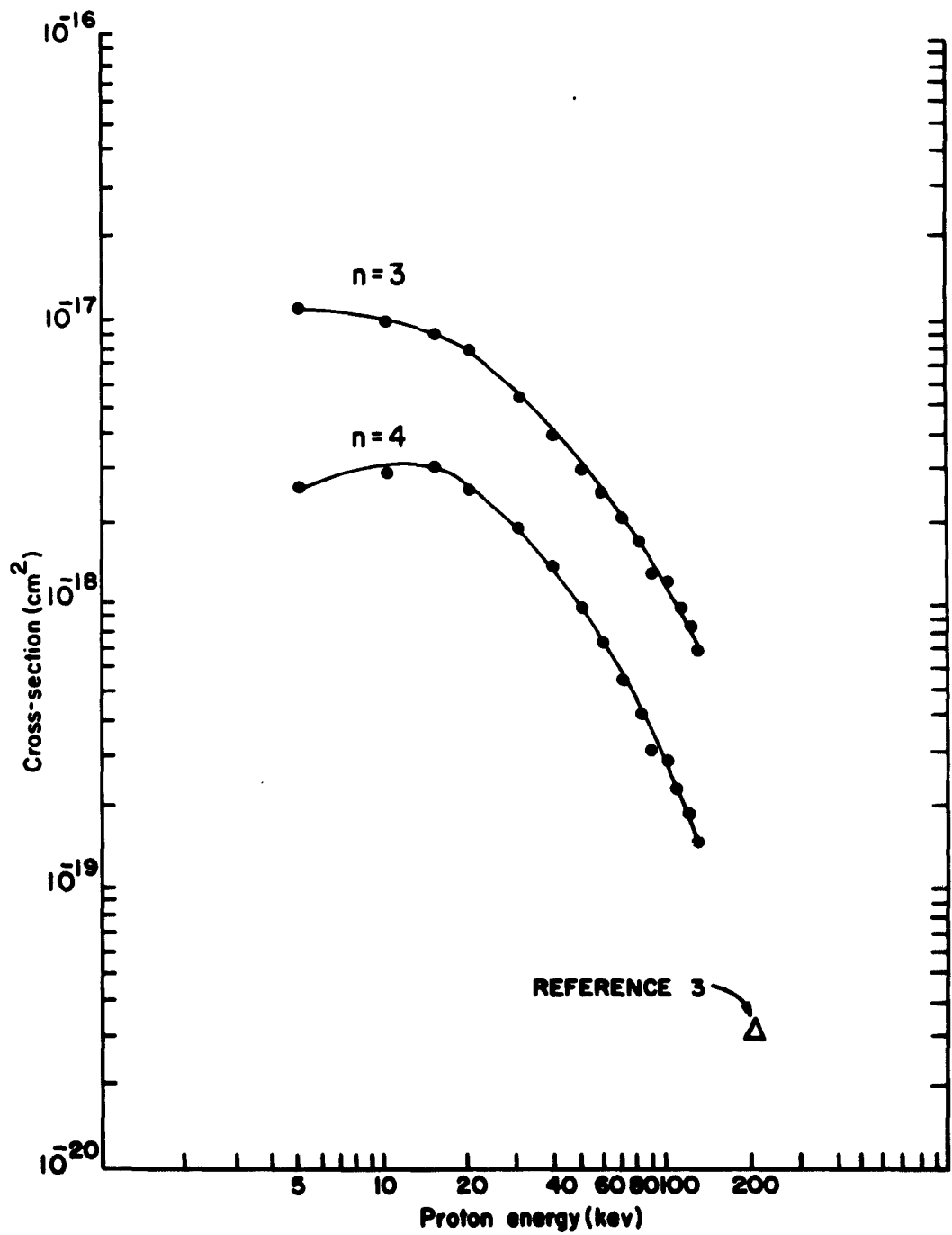

FIG. 8. Estimate of the population of the n=3 and n=4 levels of hydrogen through charge transfer in N₂

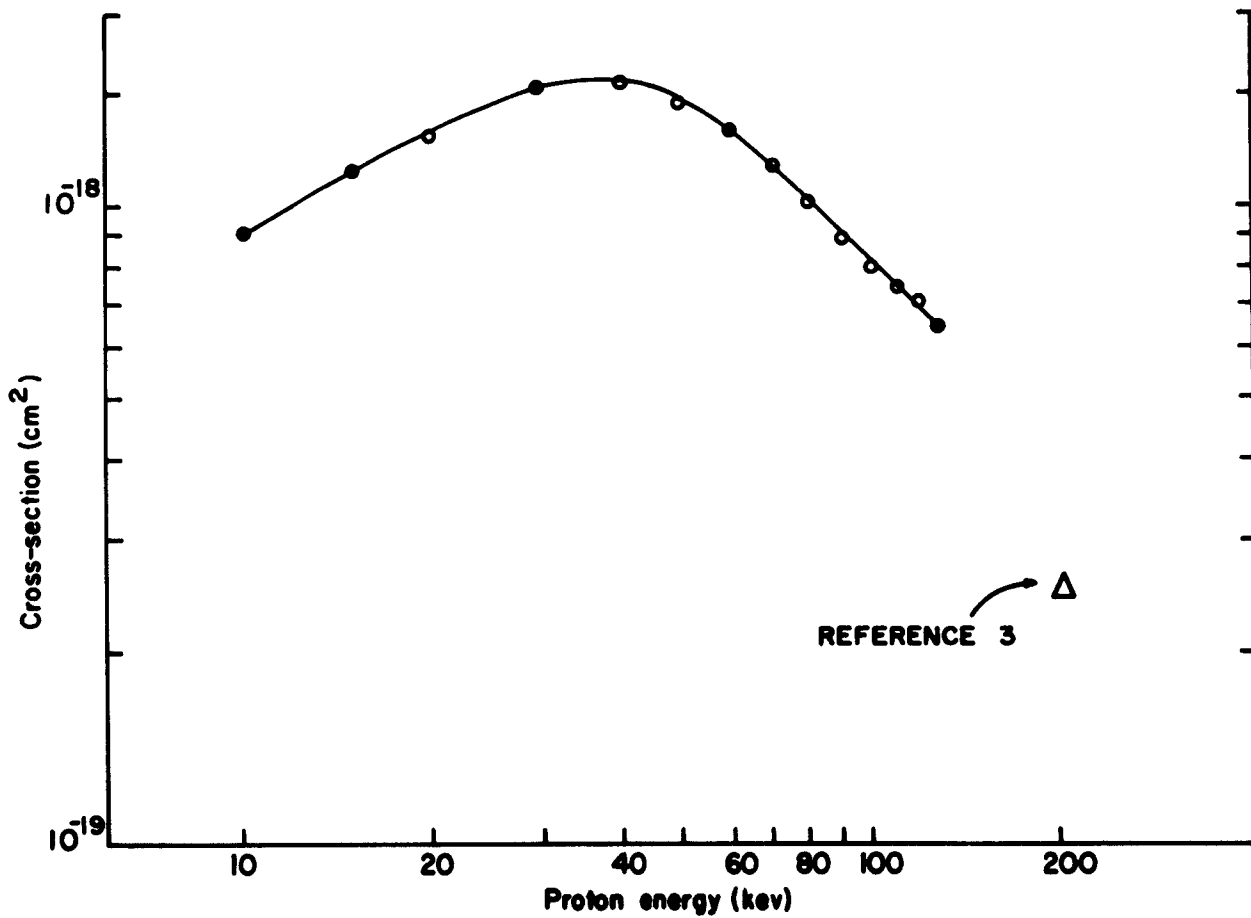

FIG. 9. Cross sections for λ 5005 and λ 5680 emission from N^+ induced by H^+ impact on N_2

Study II - Spectra Induced by H⁺ Impact on H₂

Balmer radiations, H_α, H_β and H_γ were measured for proton impact on H₂. The emissions were linear with the pressure in the operating pressure region (5μ - 10 μ Hg) down to 20 kev. Lower than 20 kev, we operated at the lowest pressure possible (a few microns). We hope that at the lower energies the neutral beam component did not appreciably affect our results.

Our results are displayed in Fig. 10 for H_α and H_β emissions, both Doppler shifted and unshifted. H_γ cross sections are included in Figs. 11 and 14. (The 5-kev point in these figures suffers limited accuracy.)

A. The Doppler Shifted Emissions

These emission cross sections are displayed in Fig. 11. Presumably these emissions are produced through the decay of fast hydrogen atoms resulting from the electron capture from hydrogen by the incident protons according to the most probable transfer reaction:

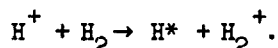

These emissions appear to peak at ~10 kev. However, the position of the peak may be affected slightly by excitation of neutrals in the beam at these energies. At 10 kev and 5μ the mean free path for charge exchange in hydrogen is about 6.5 cm. We observe the beam just as it enters the collision chamber through a pumped chamber. It would seem that many of the neutrals would be formed in the viewing region itself which is about 3cm long. A second collision could then excite neutrals which could then contribute to the Doppler shifted radiation. This may not be a negligible effect. (A similar effect holds for the Doppler unshifted radiation.)

Bates and Dalgarno¹⁰ have calculated electron capture with excited state

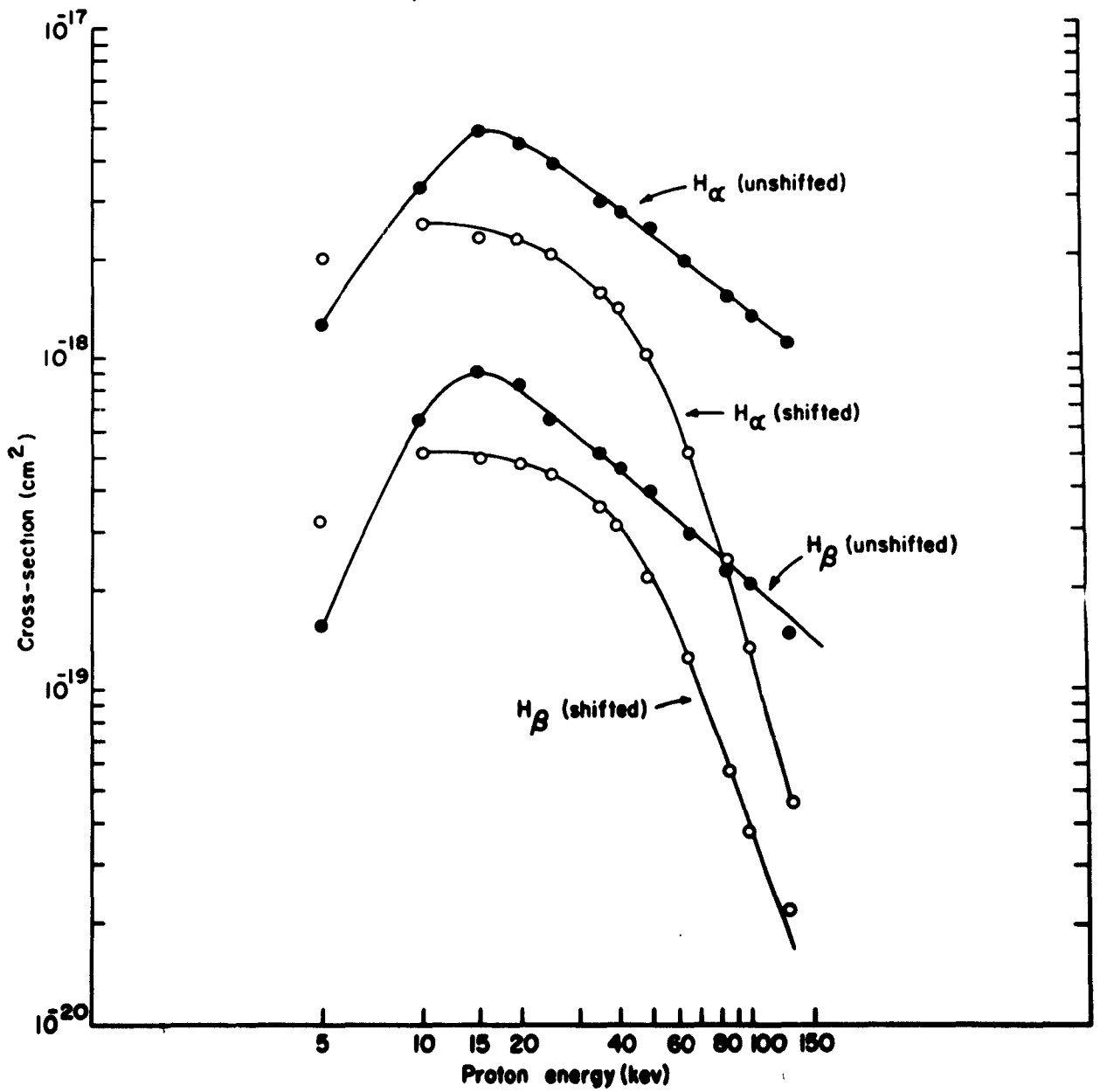

FIG. 10. H_α and H_β emissions produced by proton impact on H₂

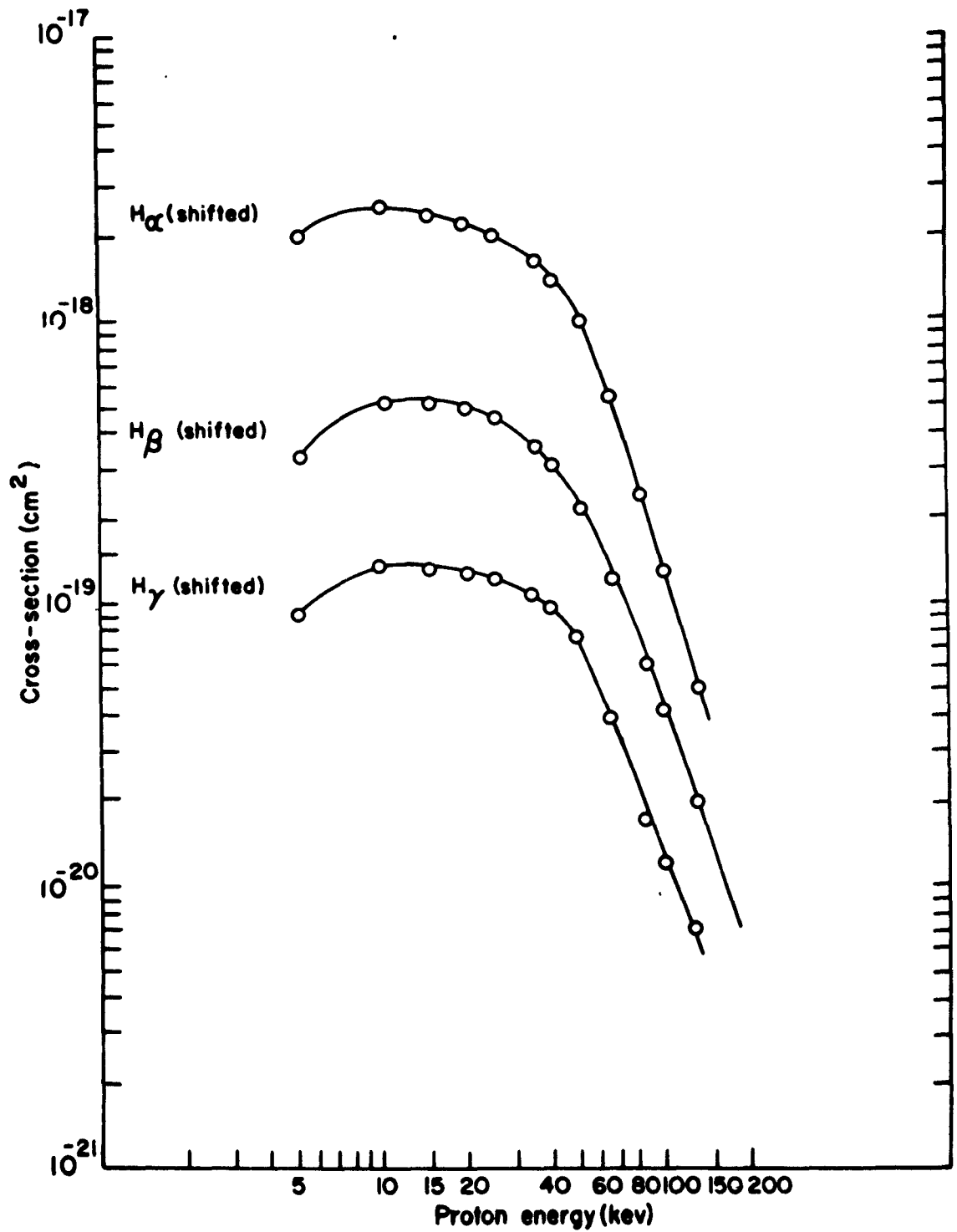

FIG. 11. Balmer emission cross sections from proton capture of an electron from molecular hydrogen

by protons from atomic hydrogen using the first Born approximation. They calculate that excited-state capture should pass through maxima ~15 keV. Our apparent peaks occur at ~10 keV for proton impact on molecular hydrogen. Fig. 12 displays level cross sections calculated by Bates and Dalgarno along with our own experimental estimates of the level cross sections per hydrogen atom. We arrived at the level cross sections as before by using the ratios of cross section for the different orbital angular momentum states as calculated by Bates and Dalgarno to obtain the relative contribution of the s, p, and d levels to the line. The experimental estimates are considerably less than predicted by theory even at the higher energies where the Born approximation is supposed to be more valid. Of course it is recognized that the experimental data are obtained on molecular-hydrogen target gas while theory is associated with atomic hydrogen as a target.

We also calculated the fraction of total capture that results in Doppler shifted H_{α} , H_{β} , H_{γ} emission using the total-capture cross sections tabulated by Allison. These fractions are displayed in Fig. 13. Bates and Dalgarno calculated this fractional quantity also for H_{α} and H_{β} . Although our fraction of capture resulting in H_{α} emission peaks at roughly their predicted energy, our experimental fractions are about a factor of 10 less.

B. The Doppler Unshifted Radiation

Cross sections for the production of these radiations are displayed in Fig. 14.

Three excitation mechanisms might be possible:

- a) $H^+ + H_2 \rightarrow H + H^* + H^+$
- b) $H^+ + H_2 \rightarrow H^+ + H^* + H^+ + e$
- c) $H^+ + H_2 \rightarrow H^+ + H^* + H$

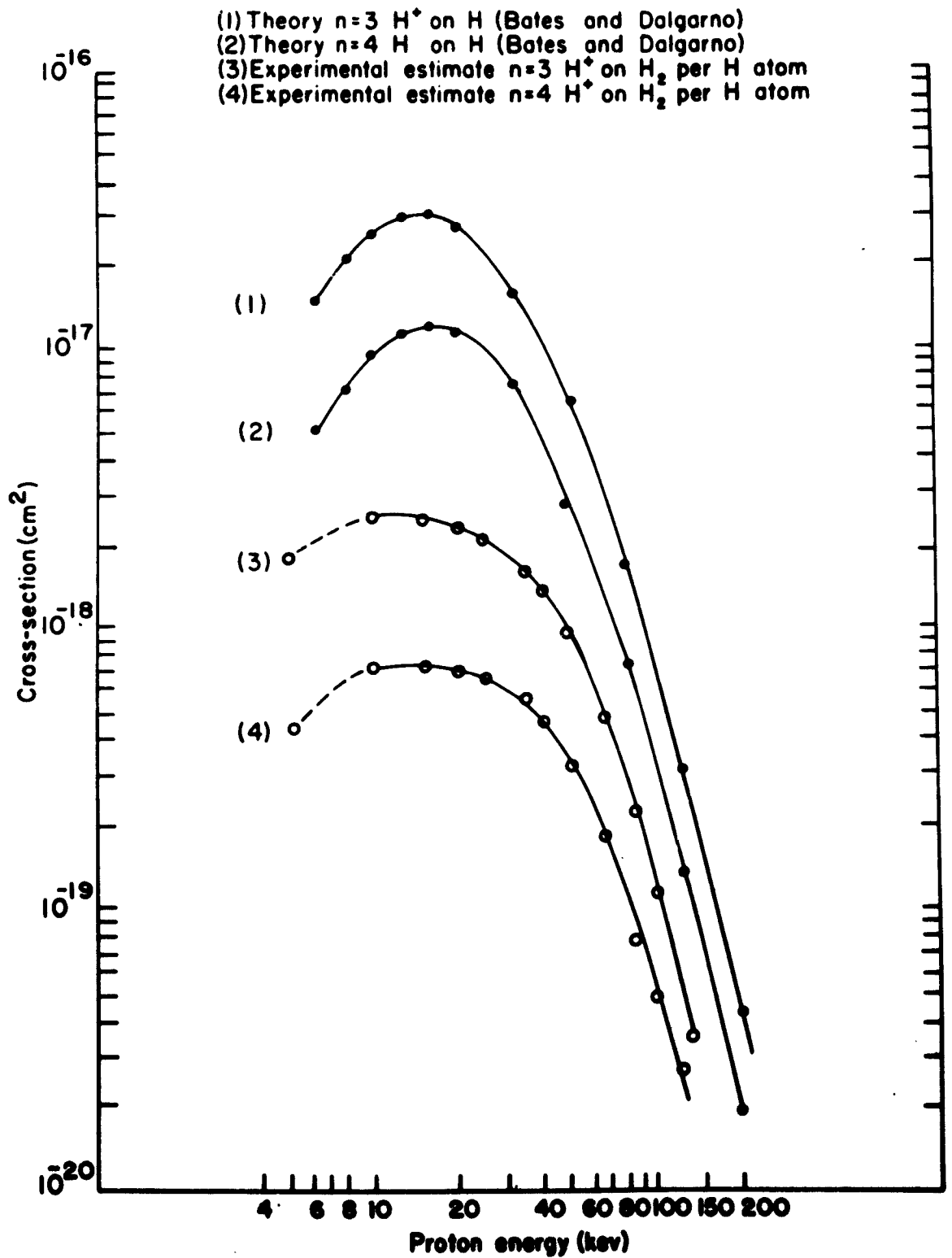

FIG. 12. Cross sections for populating the $n=3$ and $n=4$ levels of fast hydrogen atoms through electron capture from hydrogen by protons

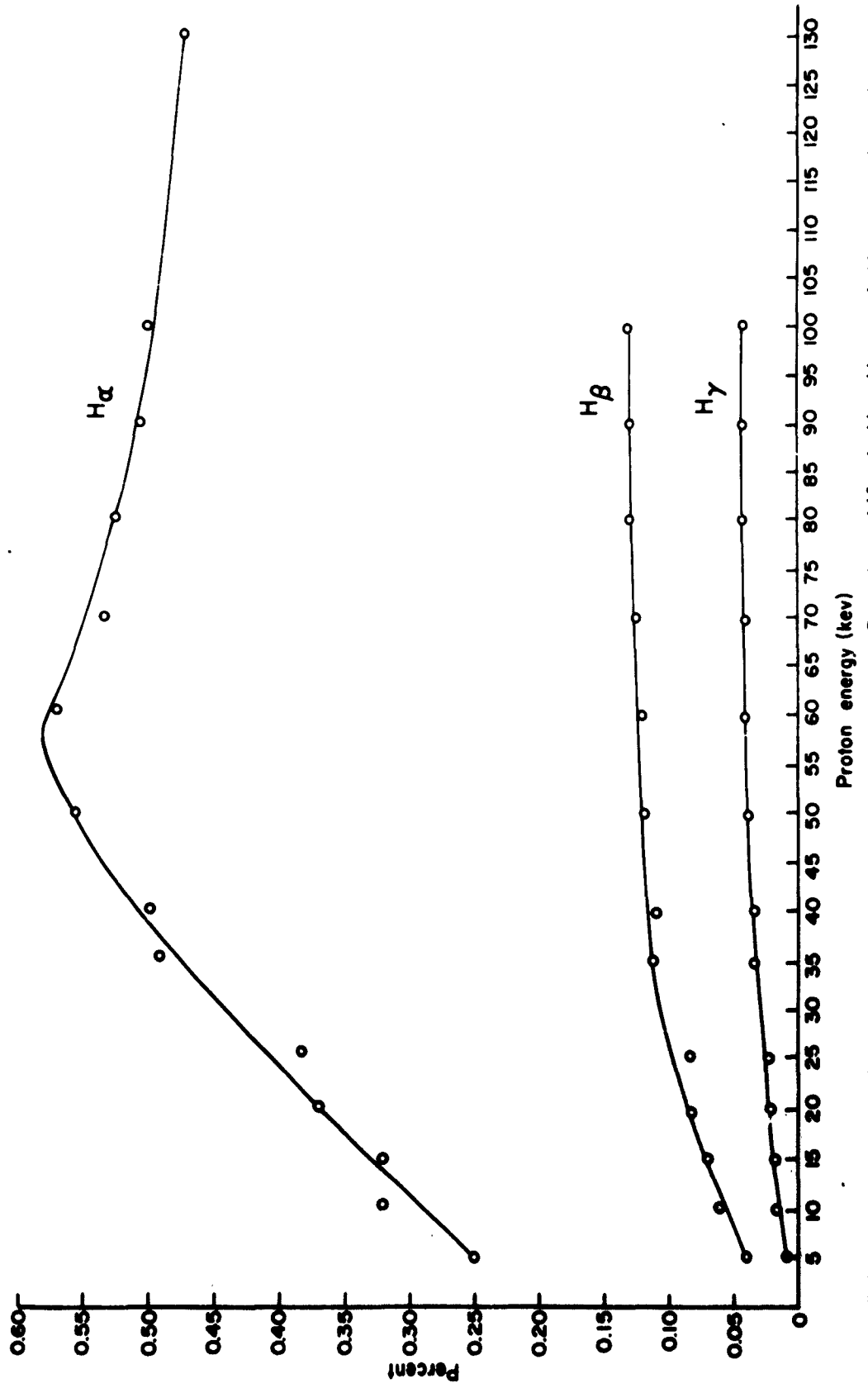

FIG. 13. Fraction of total charge transfer resulting in Doppler shifted H α , H β , and H γ , emissions in H $_2$

- (1) Theory $n = 3$ level- H^+ on H (Bates and Griffing)
- (2) Experimental estimate $n = 3$ level- H^+ on H_2 per H atom
- (3) H_α by H^+ on H_2
- (4) H_β by H^+ on H_2
- (5) H_γ by H^+ on H_2

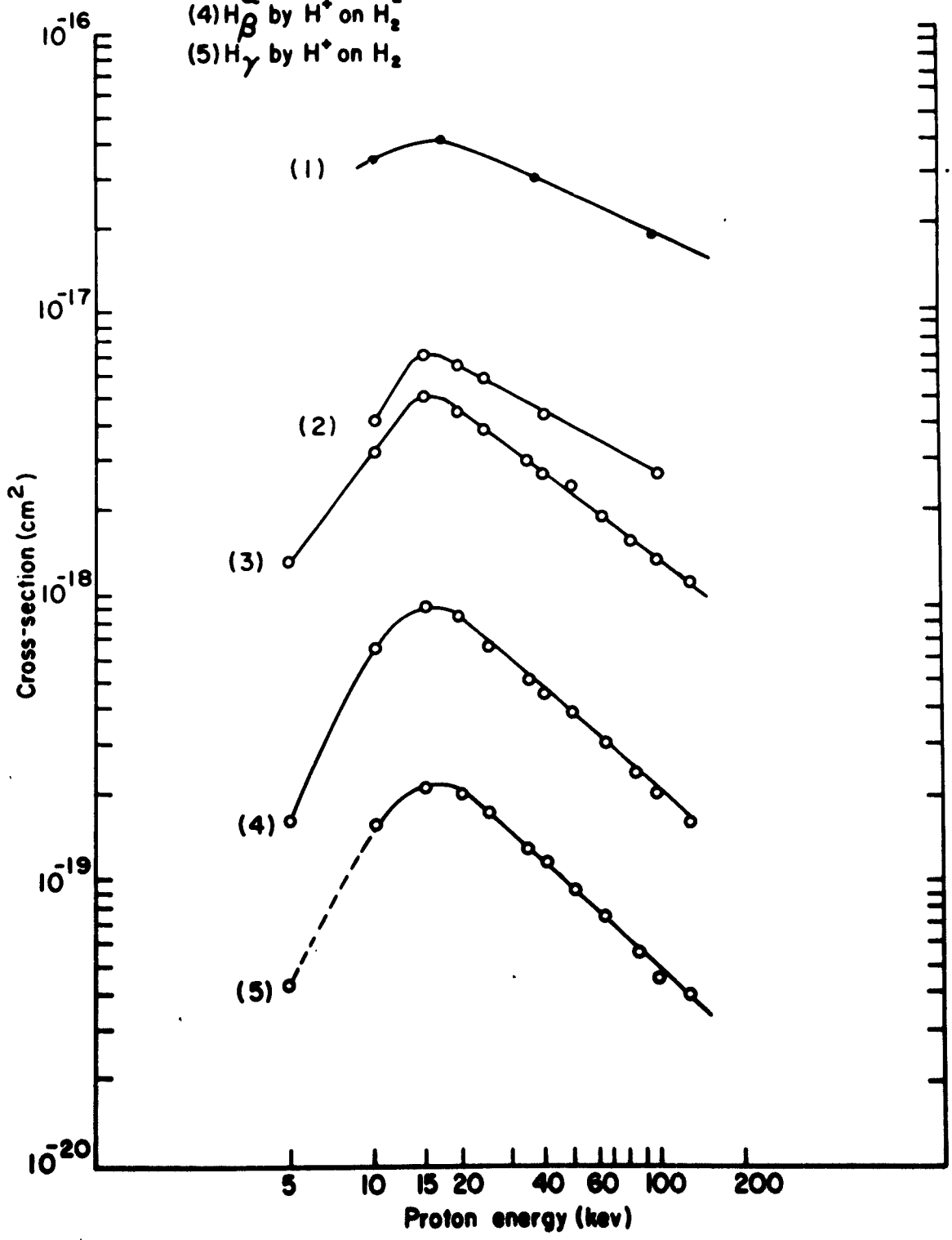

FIG. 14. Excitation cross sections for proton impact on hydrogen

The maximum excitation of the unshifted Balmer lines occurs at 15 kev. At this energy, processes (a) and (b) can be ruled out by Keane's¹² failure to observe an appreciable number of slow protons in his study of proton impact on H₂. This leaves simultaneous dissociation and excitation (c) as the most probable mechanism at this energy. Bates and Griffing¹³ have calculated the population of excited states in the reaction $H^+ + H \rightarrow H^+ + H(n)$ for $n = 2, 3$, using the first Born approximation, which has questionable validity below 25 kev for the $H^+ + H$ reaction. It is difficult to get accurate values from their plot but we have included our interpretation of their results in Fig. 14 for $n = 3$. We also include our estimate of the population cross section of the $n = 3$ level by proton impact on molecular hydrogen per hydrogen atom. We referred to their calculations to obtain the factors required to transform the our H_α measurements to level measurements. Again our results are low compared with theory.

The unshifted Balmer emissions seem to go roughly as $E^{-0.85}$ where E is the proton energy. This seems to hold from about 25 kev to the higher energies.

There is always the question of the role of cascade in populating levels. We used the calculations of Bates and Dalgarno and Bates and Griffing to estimate the effect of cascade on the H_α and H_β shifted and unshifted emission. On this basis it would appear that cascade contributes about 10 per cent and 5 per cent to the Doppler unshifted and Doppler shifted H_α lines, respectively, while cascade contributes about 2 per cent to both the Doppler unshifted and shifted H_β emissions.

Study III - H⁺ Impact on He

Several helium line cross sections were determined in this study as well as the cross sections for the Doppler shifted H_α and H_β emissions. Of the helium emissions studied, only the $4^1S \rightarrow 2^1P$ and $5^1S \rightarrow 2^1P$ transitions and

the He_{II} (4 → 3) λ 4686 line were approximately linear with pressure in the pressure range used (from 20 μ Hg to 1.5 μ Hg).

The equipment used was the same, but since our study included measurements of the 3 ¹S → 2 ¹P as (λ 7281A) line our standard lamp had to be extrapolated beyond the 6500A Yerkes Observatory calibration limit. This was done by plotting $\log_e \lambda^5 E_\lambda$ vs $1/\lambda$ (the short-wave-length approximation to the Planck radiation law) as a straight line through the calibration points and extrapolating this line into the desired region. The spectrometer - photomultiplier system was checked at λ 7281 to make certain that appreciable radiation from the standard lamp was not appearing in the second order. This proved to be negligible within experimental error.

A. Balmer Emissions

H $_{\alpha}$ and H $_{\beta}$ emissions were studied. The results are displayed in Fig. 15. As can be seen, these emissions peak at about 30 kev, which is comparable to the energy position of the peak in the total charge transfer in helium (~25 kev).

The results can be compared with the calculations of Mapleton¹¹ on electron capture from helium by protons. Again we appeal to calculations to obtain the contributions of the different orbital states in getting the proper factors to transform our line cross sections into level cross sections. Fig. 16 compares our experimental estimate of the level population with the calculations of Mapleton for the n = 3 level. Again the results are low compared with theory even at the higher energies where the Born approximation is assumed valid.

We also calculated the fraction of total charge transfer that results in H $_{\alpha}$ and H $_{\beta}$ emission for each energy. These are displayed in Fig. 17.

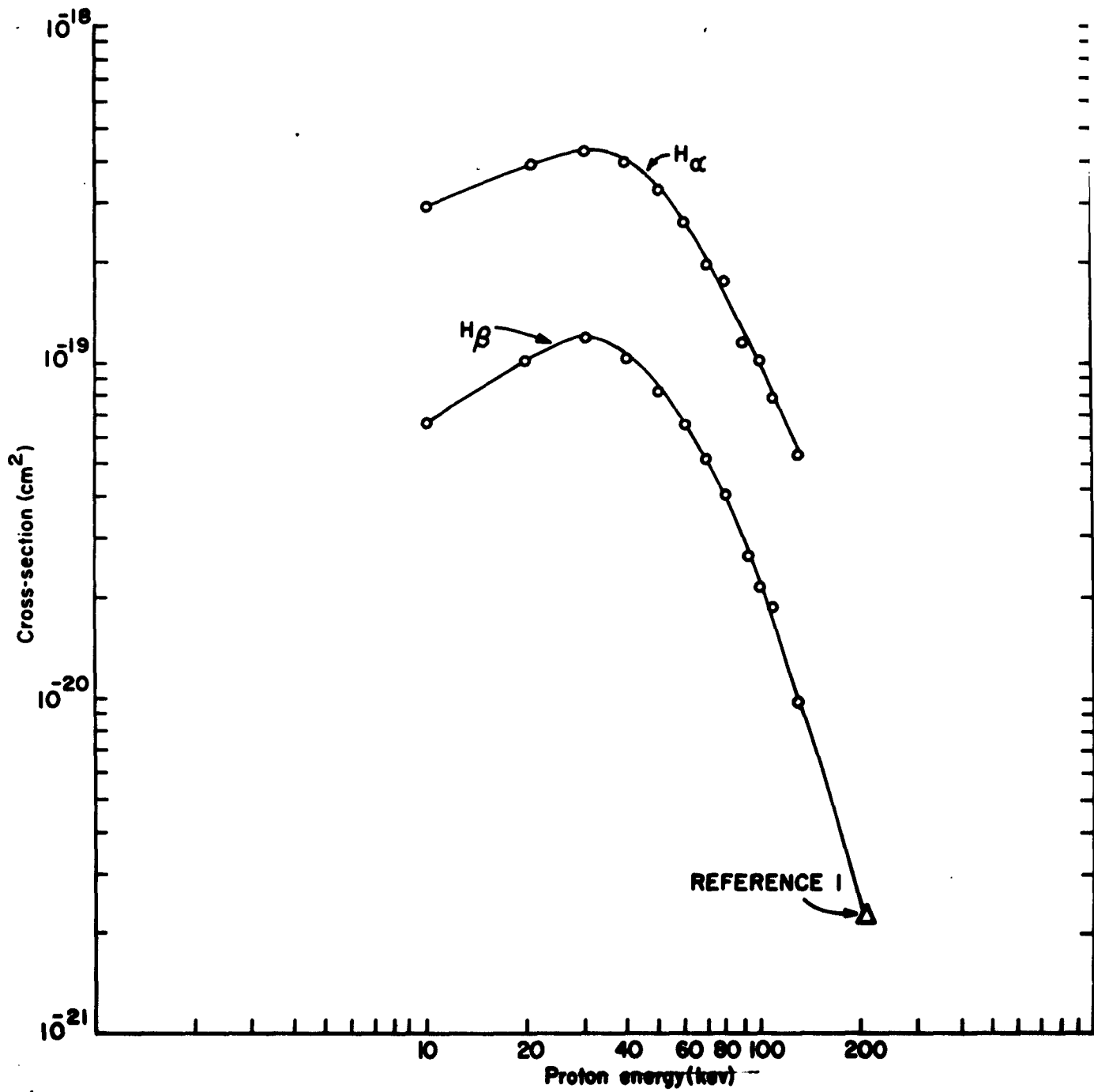

FIG. 15. Cross sections for the production of H_{α} and H_{β} emissions by proton impact on helium

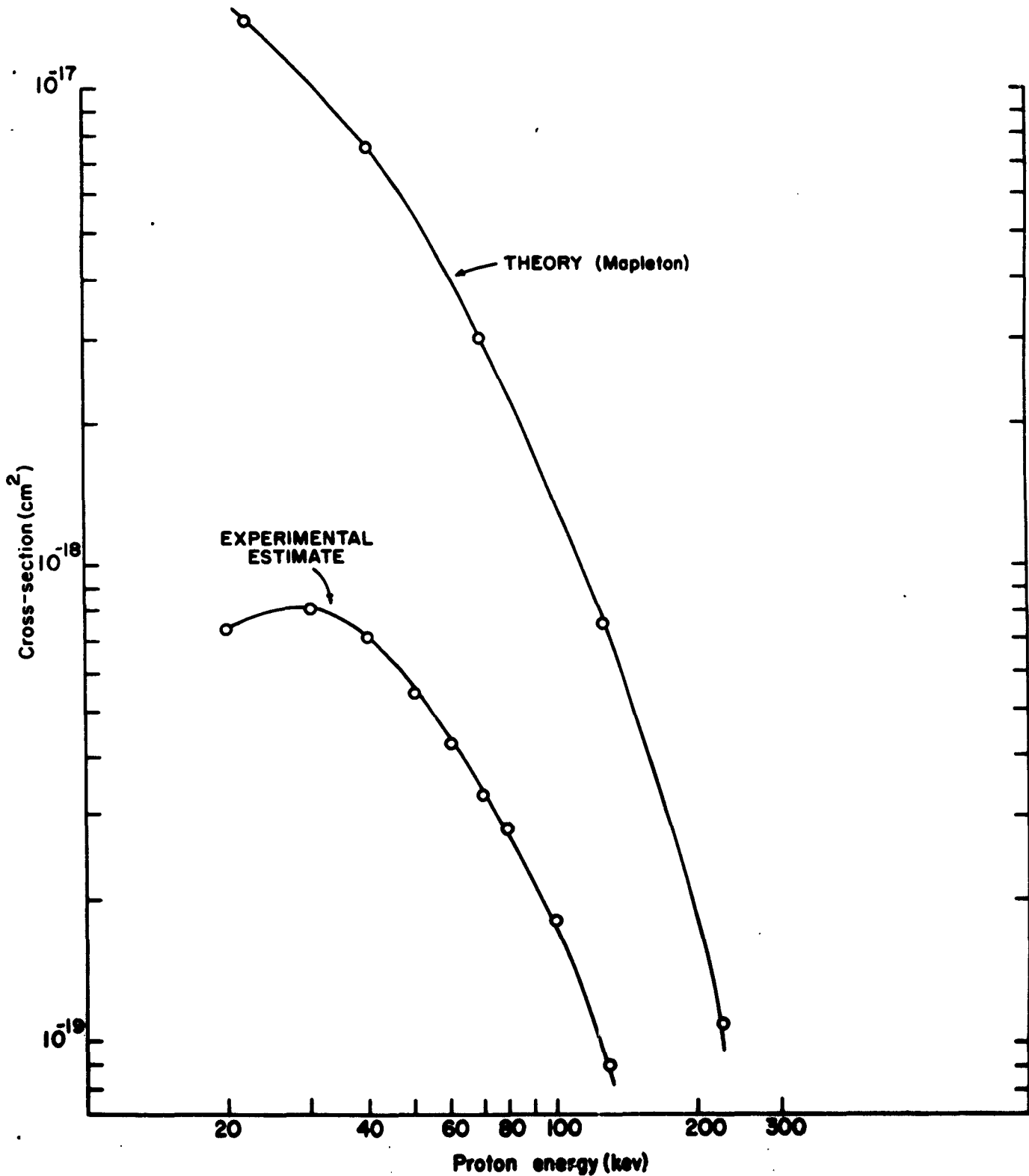

FIG. 16. Cross-section for populating the n=3 level in hydrogen through electron capture by protons in helium

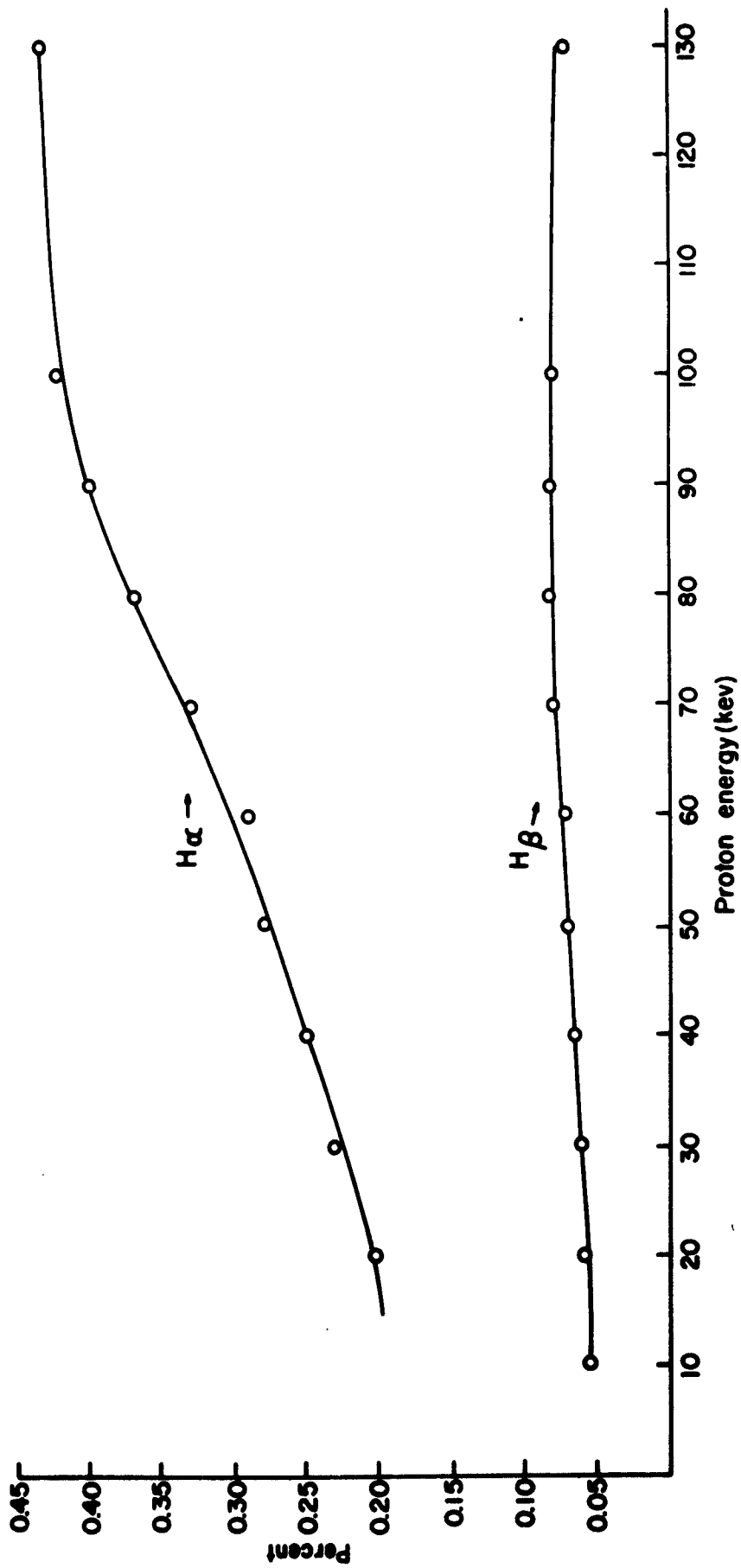

FIG. 17. Fraction of total charge transfer events resulting in H α and H β emissions in helium

B. The He_{II} (4 → 3) line (λ686A)

This radiation results from the decay of the excited He⁺ ion. Two mechanisms are competing here. Charge transfer is dominant at the lower energies while simultaneous ionization and excitation becomes dominant at the higher energies. Fig. 18 displays our results for this line. This line peaks at about 40 kev. At this energy, charge transfer is most probably dominant. The population of the n = 4 level can be estimated from Mapleton's work on charge transfer¹¹ and simultaneous excitation and ionization¹⁴ in helium. His charge-transfer work includes only the n = 2 excited level, but we used the n⁻³ law to estimate the n = 4 level. His ionization work includes the n = 3 level, and we again used the n⁻³ law to obtain values for n = 4. At about 120 kev it appears that charge transfer and ionization are about equally effective in populating the n = 4 level. At 200 kev, charge transfer can be neglected. We include the theoretical estimate of the n = 4 population along with our estimate from the results on the λ686 line in Fig. 19. The agreement is apparently fairly good where the Born approximation is expected to hold. Both estimates are quite rough, however, in particular the estimate from experiment.

C. Population of the n¹S Levels

Cross sections for direct excitation into the 4¹S and 5¹S levels (neglecting cascade) could be obtained most easily since the apparent cross sections for the 4¹S → 2¹P (λ5047A) line and the 5¹S → 2¹P (λ4438A) line were approximately independent of the pressure at lower pressures. However, the 3¹S → 2¹P (λ7281A) line was noticeably pressure-dependent, with the apparent cross section increasing as the pressure increased. This effect is probably caused by the cascade from n¹P levels (n > 3) whose population is pressure-sensitive. The 3¹S level is more heavily populated by cascade than

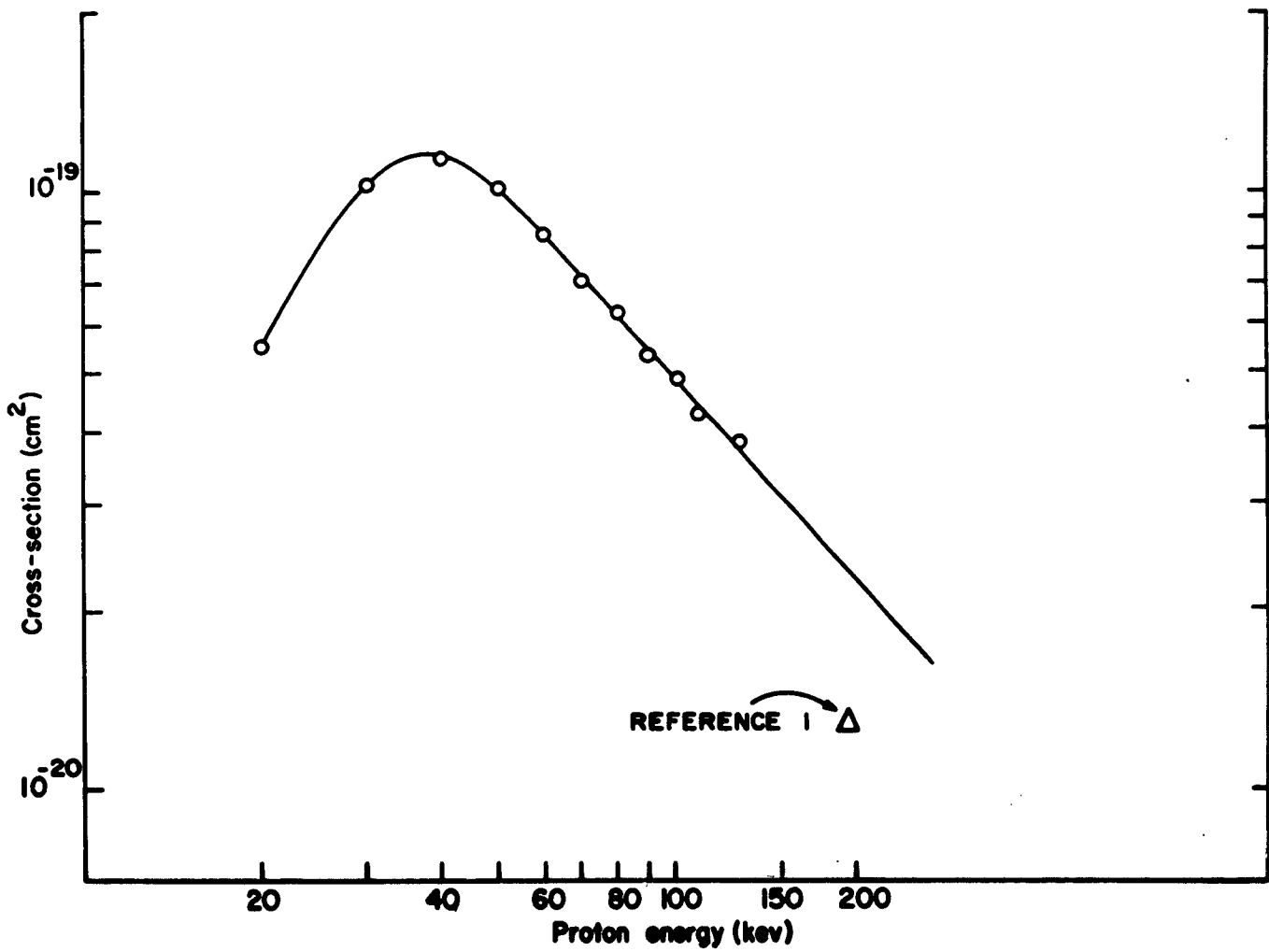

FIG. 18. Cross section for the production of the He_{II} (4→3) radiation by proton impact on helium

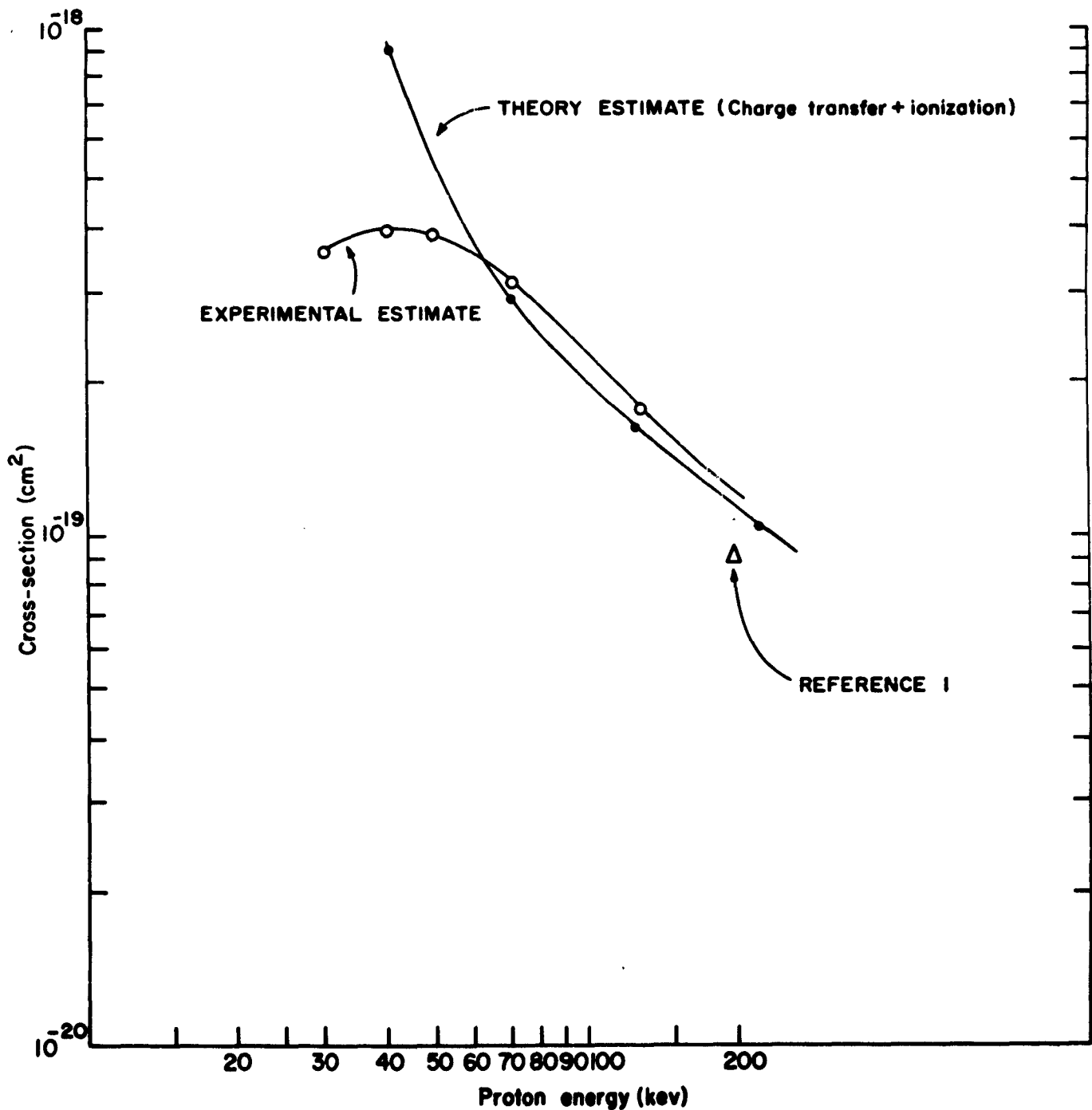

FIG. 19. Cross sections for the population of the $n=4$ level of He^+ by proton impact on He

higher-lying $1S$ levels. Fig. 20 displays our results. Fig. 21 displays our estimate of the $1S$ level population. Branching ratios were obtained by using the transition probabilities tabulated by Gabriel and Heddle.¹⁵ The $3\ 1S$ results must be considered only tentative since we have not really looked fully into the pressure dependency.

Included in Fig. 21 are the results of Van Eck et al.¹⁶ Our results seem to be higher than theirs where the data overlap. Further, our results do not seem to extrapolate well to our previous measurements at 200 kev. This present work seems to indicate our 200-kev data are low, a conclusion also reached by Sternberg and Tomas.¹⁷ On the other hand our 200-kev points align well with the work of Van Eck et al.¹⁶ No explanation is offered at the present.

This excitation can be compared with the excitation by electrons of the same velocity. Stewart and Gabathuler¹⁸ determined that the $4\ 1S \rightarrow 2\ 1P$ and $5\ 1S \rightarrow 2\ 1P$ transitions have a maximum cross section of $16.3 \times 10^{-20}\ \text{cm}^2$ and $4.9 \times 10^{-20}\ \text{cm}^2$, respectively at 36 ev for electron impact. These maximum cross sections are 2.6 and 3.2 smaller than our respective maximum cross section, and, further, we might have expected our maximum to occur at about 66 kev which corresponds to the velocity of a 36-volt electron. Instead, our maximum occurs at ~50 kev. (It is of some interest to note that our previously determined 200-kev points¹ for the $4\ 1S$ and $5\ 1S$ levels correspond closely to the 108-ev data of Gabriel and Heddle.¹⁵ The velocities of these particles at these energies are about equal.)

D. Excitation to the $3\ 1P$ Level of Helium

A tentative cross section for direct excitation into the $3\ 1P$ level was obtained by essentially using the method described by Gabriel and Heddle.¹⁵

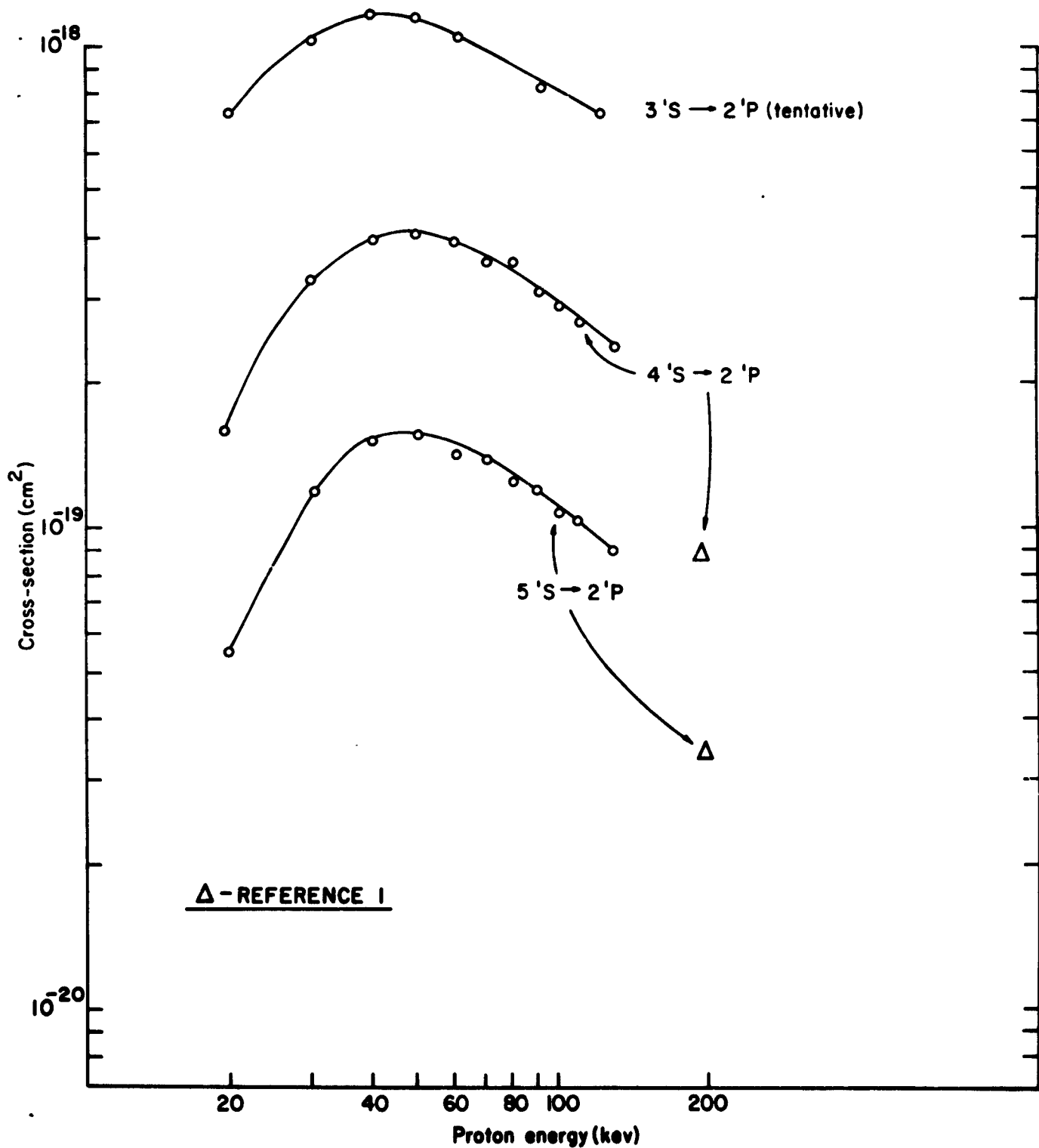

FIG. 20. Cross sections for the production of $n'S \rightarrow 2'P$ radiation for $n=3,4,5$ by H^+ impact on He

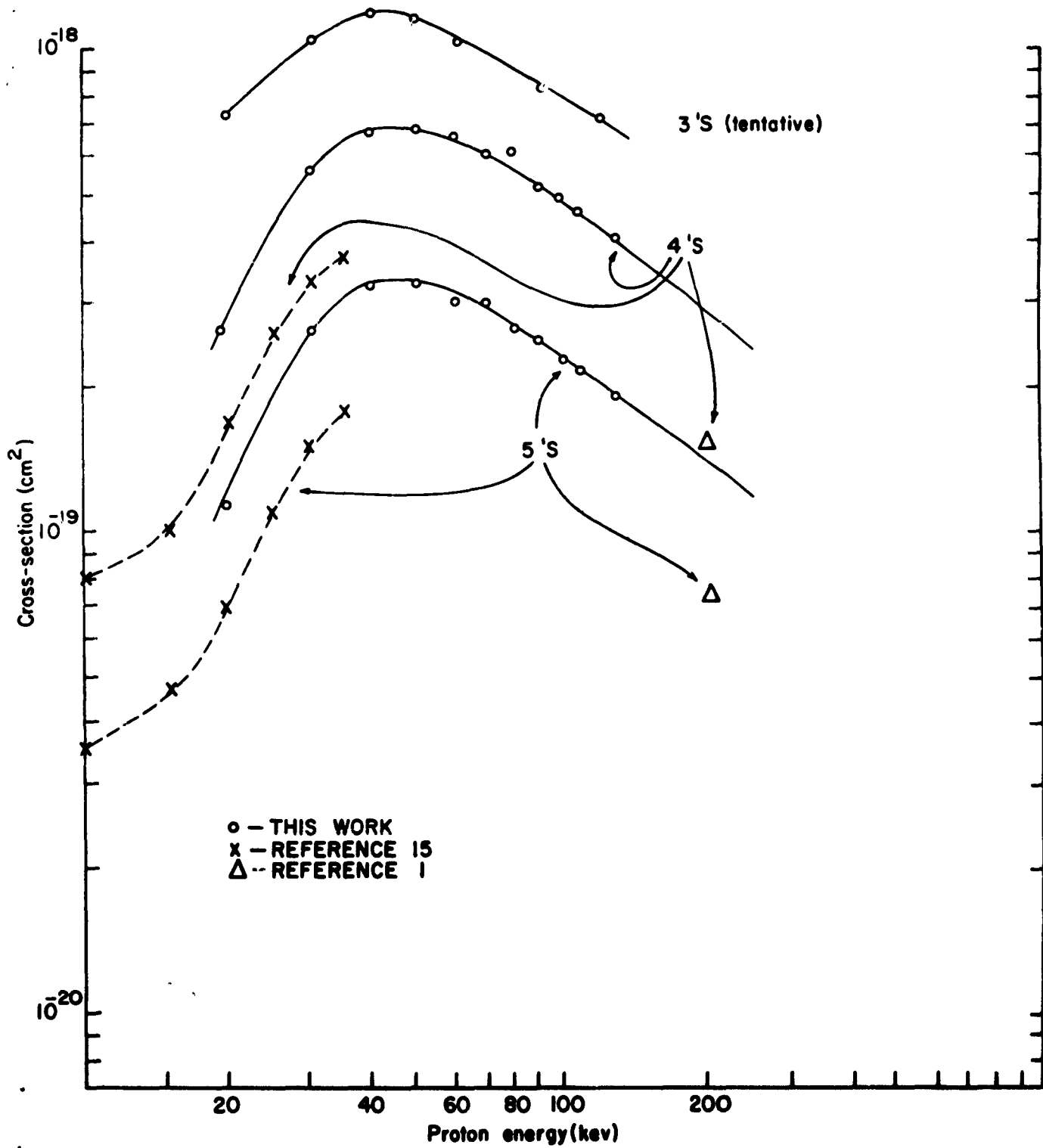

FIG. 21. Population cross sections for 3'S, 4'S, and 5'S levels in helium

It was assumed that the cross section for populating the 3^1P level by direct impact could be expressed by

$$Q(3^1P) = Q'(3P2) \left[A(3P1) g(\rho) + [A(3P2) + A(3P3)] \right] / A(3P2)$$

where $Q'(3P2)$ and $A(3P2)$ are the apparent cross sections for producing the $3^1P \rightarrow 2^1S$ transition and the associated transition probability, respectively; $A(3P1)$ and $A(3P3)$ are the transition probabilities for $3^1P \rightarrow 1^1S$ and $3^1P \rightarrow 3^1S$, respectively; and $g(\rho)$ is the imprisonment of resonance radiation factor. An effective imprisonment radius was chosen to give the same $Q(3^1P)$ for the different $Q'(3P2)$ at different pressures for a given energy (70 and 90 kev). It was assumed that this radius was independent of energy. This radius seemed to be ~ 0.4 cm for our apparatus. (This is a rather meaningless number in our case since it depends on parameters external to the collision chamber, such as the spectrometer slit width.) Further work is anticipated in order to increase our confidence in this measurement. It may well be off by as much as a factor of two.

It is to be noted that the 3^1P excitation appears to be close to a maximum at 130 kev. This excitation can be compared with the theoretical work of Bell.¹⁹ He predicts a maximum cross section of about 3.1×10^{-18} cm² at 124 kev. This is good agreement with our results indicated by Fig. 22. However, our experimental values are quite uncertain at the present. (P excitation reaches a maximum at about 100 ev for electron impact¹⁸ which corresponds to about 185-kev proton impact for equal velocities.)

E. The $4^1D \rightarrow 2^1P$ Line

This line is pressure-dependent presumably because of collisions of second kind where atoms in the 1^1P state transfer their excitation. Fig. 23 shows an excitation curve for this line for a pressure of $\sim 4\mu$. As can be seen, the

Cross-section (cm^2)



FIG. 22. Cross sections for populating the 3^1P state in helium by proton impact (tentative)

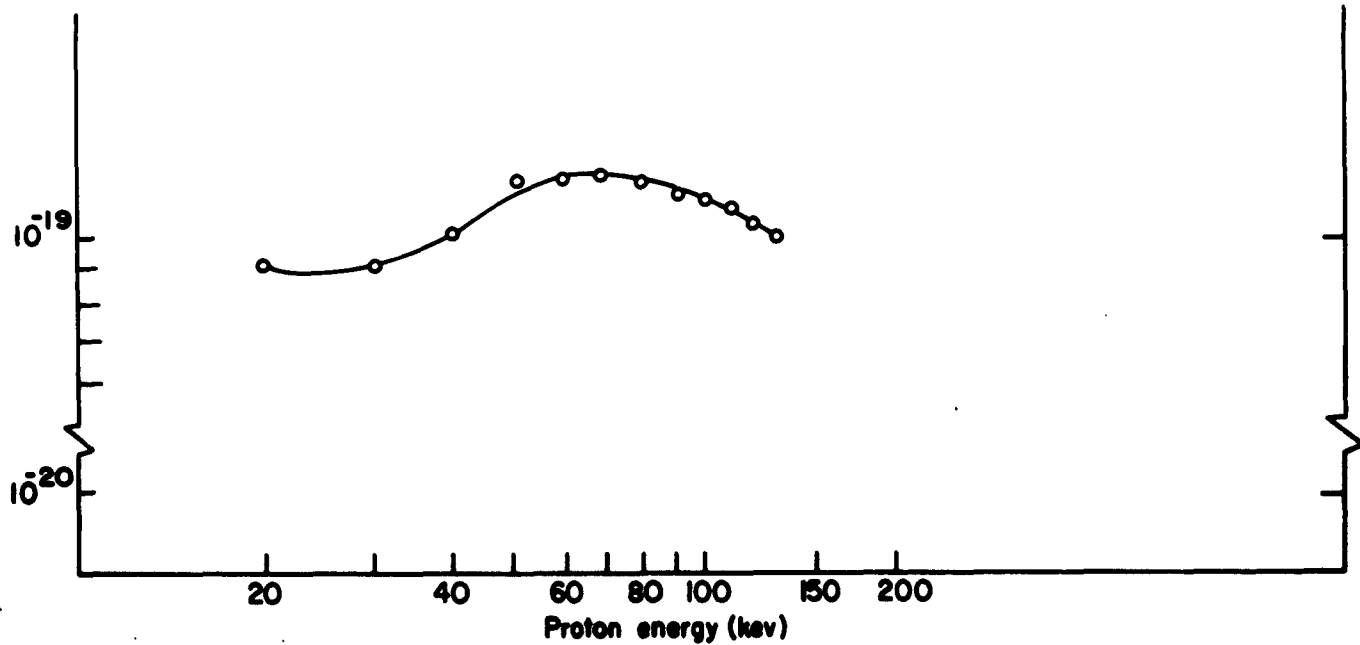

FIG. 23. Apparent cross sections for exciting the $4^1\text{D} \rightarrow 2^1\text{P}$ transition in helium by proton impact at about 4μ pressure

excitation appears to maximize at about 70 kev. (Stewart and Gabathuler¹⁸ find this line maximizes at about 45 ev for electron impact which corresponds to about 80-kev proton impact for equal velocities.)

Acknowledgements

The authors wish to thank Lynn Hatfield, William Evans, Darrell Bolding, and David Kay for their aid. They wish also to thank Travis Walton for his fine job of engineering most of the accelerator construction.

References

1. R. H. Hughes, R. C. Waring, and C. Y. Fan, Phys. Rev. 122, 525 (1961).
2. W. F. Sheridan, O. Oldenberg, and N. P. Carleton, (Abstracts) Second International Conference on the Physics of Electronic and Atomic Collisions, University of Colorado, 1961, page 159.
3. R. H. Hughes, J. L. Philpot, and C. Y. Fan, Phys. Rev. 123, 2084 (1961).
4. G. Herzberg, Ann. Phys. Lpz. 86, 191 (1928).
5. M. E. Pillow, Proc. Phys. Soc. A 64, 772 (1951).
6. D. T. Stewart, Proc. Phys. Soc. A 69, 437 (1956).
7. D. R. Bates, Mon. Not. R. Astr. Soc. 112, 614 (1952).
8. R. N. Il'in, V. V. Afrosimov, and N. V. Fedorenko, J. Exptl. Theoret. Phys. (USSR) 36, 41 (1959).
9. S. K. Allison, Revs. Mod. Phys. 36, 1137 (1958).
10. D. R. Bates and A. Dalgarno, Proc. Phys. Soc. A 66, 972 (1953).
11. R. A. Mapleton, Phys. Rev. 122, 528 (1961).
12. J. P. Keene, Phil. Mag. 40, 369 (1949).
13. D. R. Bates and G. Griffing, Proc. Phys. Soc. A 66, 961 (1953).
14. R. A. Mapleton, Phys. Rev. 109, 1166 (1958).
15. A. H. Gabriel and D. W. O. Heddle, Proc. Roy. Soc. A 258, 124 (1960).
16. J. Van Eck, F. de Heer, and J. Kistemaker (1962 to be published). Their values are quoted from Lectures on Heavy Particle Interactions, Kaman Nuclear, Colorado Springs, July 2-18, 1962.
17. Z. Sternberg and P. Tomas, Phys. Rev. 124, 810 (1961).
18. D. Stewart and E. Gabathuler, Proc. Phys. Soc. 74, 473 (1959).
19. R. J. Bell, Proc. Phys. Soc. 78, 903 (1961).

Appendix Table I. Calculated Minimum Energy Defect, ΔE , for
 Certain Charge-changing Reactions (in Electron Volts).

Level (n)	Reaction								
	A	B	C	D	E	F	G	H	
1	10.9	2.0	1.0	2.6	7.9	2.2	12.8	4.5	
2	21.1	12.1	9.1	12.7	18.1	12.3	23.0	14.6	
3	23.0	14.0	11.0	14.6	20.0	14.2	24.9	16.5	
4	23.6	14.7	11.6	15.3	20.6	14.8	25.5	17.2	

Reaction A: $H^+ + He \rightarrow H(n) + He^+$ where $H(n)$ represents electron capture into
 the nth level of hydrogen.

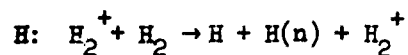
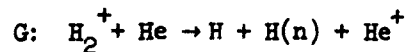
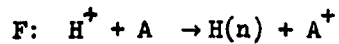
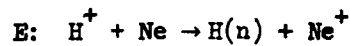
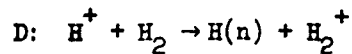
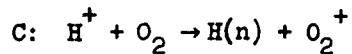
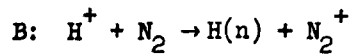

[It is assumed in these calculations that the H_2^+ ion exists in a most probable
 vibrational state 0.75 ev above the ground vibrational state.]

Appendix Table II. Calculated Minimum Energy Defect, ΔE , for
Certain Excitation Reactions in N_2 (in Electron Volts).

Level (α)	Reaction	A	B	C	D	E	F
α_1		2.0	15.5	8.3	21.9	22.8	36.4
α_2		5.2	18.7	28.9	42.5	44.4	57.0
α_3				31.4	44.9	46.9	59.4

Reaction A: $H^+ + N_2 \rightarrow H + N_2^+(\alpha)$ where $\alpha_1 \equiv X^2\Sigma v = 0$ and

$$\alpha_2 \equiv B^2\Sigma v = 0$$

B: $H^+ + N_2 \rightarrow H^+ + N_2^+(\alpha) + e$ where α same as reaction A

C: $H^+ + N_2 \rightarrow H + N + N^+(\alpha)$ where $\alpha_1 \equiv$ ground state,

$$\alpha_2 \equiv 3p^3D \text{ and } \alpha_3 \equiv 3d^3F^0$$

D: $H^+ + N_2 \rightarrow H^+ + N + N^+(\alpha) + e$ where α same as reaction C

E: $H^+ + N_2 \rightarrow H + N^+ + N^+(\alpha) + e$ where α same as C

F: $H^+ + N_2 \rightarrow H^+ + N^+ + N^+(\alpha) + 2e$ where α same as C

Appendix Table III. Calculated Minimum Energy Defect, ΔE , for Certain Excitation Reactions in Helium and Hydrogen (in Electron Volts).

Level (n)	Reaction	A	B	C	D-E	F
1		24.5	10.9	4.5	1.9	6.4
2		65.1	51.6	14.6	12.1	16.5
3		72.6	59.1	16.5	13.9	18.4
4		75.2	61.7	17.2	14.6	19.1

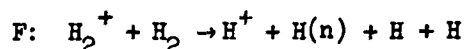
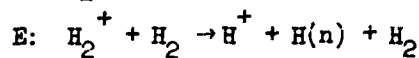
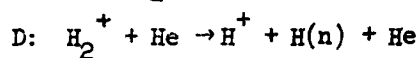
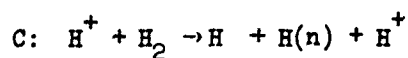
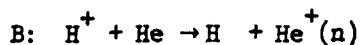
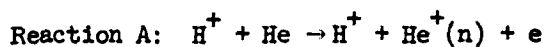

The Massey adiabatic parameter, $\frac{a \Delta E}{hv}$, can be expressed for H^+ impact as $\frac{a (\Delta E) E_0^{-\frac{1}{2}}}{17.4}$ when a is expressed in Angstrom units, ΔE in ev, and E_0 is

incident ion energy in kev.

The parameter can be expressed as $\frac{a (\Delta E) E_0^{-\frac{1}{2}}}{12.3}$ for H_2^+ impact where

a , ΔE , and E_0 are in the same units as before.

Erratum: Spectra Induced by 200-kev Proton Impact on Nitrogen, R. H. Hughes,
J. L. Philpot, and C. Y. Fan, Phys. Rev. 123, 2084 (1961).

The formula for reducing the H_{β} cross section to the $n = 4$ level population cross section should read:

$$\sigma(n = 4) = \sigma(H_{\beta}) [1 + R_1 + R_2] \\ \frac{1}{T(4s)A(4s \rightarrow 2p) + R_1 T(4p)A(4p \rightarrow 2s) + R_2 T(4d)A(4d \rightarrow 2p)}$$

where R_1 and R_2 are as previously defined and the T's and A's are indicated lifetimes and transition probabilities, respectively.

Because of a shortage, this copy does not contain reprints of the following publications:

- (1) R. H. Hughes, R. C. Waring, and C. Y. Fan, Phys. Rev. 122, 525 (1961).
- (2) R. H. Hughes, J. L. Philpot, and C. Y. Fan, Phys. Rev. 123, 2084 (1961).
- (3) R. H. Hughes, J. Opt. Soc. Am. 51, 696 (1961).

Errata - Technical Report Contract AF 19(604)-4966 (AFC-RL-63-225)

- a) Fig. 6. H_{α} and H_{β} emission from H^+ impact on N_2 . The H_{α} curve should be plotted using the following table:

$\sigma(10^{-18} \text{ cm}^2)$	Energy (keV)														
	5	10	15	20	30	40	50	60	70	80	90	100	110	120	130
	5.7	5.2	4.7	4.0	2.8	2.0	1.5	1.0	0.7 ₉	0.5 ₈	0.4 ₅	0.3 ₄	0.2 ₇	0.2 ₂	0.1 ₉

This contains new data obtained by observing perpendicular to the beam. The previous values shown in Fig. 6 in the region above 50 keV are too high because H_{α} was shifted too near a suspected N_{II} line at $\lambda 6482\text{\AA}$. The data from 10 keV to 50 keV remains the same.

- b) Fig. 7. Fraction of total charge transfer resulting in H_{α} and H_{β} emission by H^+ impact on N_2 .

The plot for H_{α} should be corrected in accordance with the above table.

This should read:

% H_{α}	Energy (keV)											
	15	20	30	40	50	60	70	80	90	100	120	130
	0.55	0.51	0.49	0.45	0.44	0.34	0.36	0.38	0.36	0.34	0.34	0.35

- c) Fig. 8. Estimate of the population of the $n = 3$ and $n = 4$ level of hydrogen through charge transfer in N_2 .

The $n = 3$ curve should be corrected by using the ratio of the new values for H_{α} emission to the values read from Fig. 6.

- d) Fig. 17. Fraction of total charge transfer events resulting in H_{α} and H_{β} emission in helium.

On the H_{α} curve the 90 and 100 keV points should read 0.30% and 0.34%, respectively, instead of 0.40% and 0.44%, respectively. Further the 130 keV point is closer to 0.39% than 0.43% as shown.