

UNCLASSIFIED

---

---

AD 401 111

*Reproduced  
by the*

ARMED SERVICES TECHNICAL INFORMATION AGENCY  
ARLINGTON HALL STATION  
ARLINGTON 12, VIRGINIA



---

---

UNCLASSIFIED

NOTICE: When government or other drawings, specifications or other data are used for any purpose other than in connection with a definitely related government procurement operation, the U. S. Government thereby incurs no responsibility, nor any obligation whatsoever; and the fact that the Government may have formulated, furnished, or in any way supplied the said drawings, specifications, or other data is not to be regarded by implication or otherwise as in any manner licensing the holder or any other person or corporation, or conveying any rights or permission to manufacture, use or sell any patented invention that may in any way be related thereto.

CATALOGED BY ASTIA

AS AD NO. ~~401111~~

DEVELOPMENT AND TESTING OF MOTION  
MEASURING INSTRUMENTATION FOR THE  
XCH-6 HYDROFOIL CRAFT  
REPORT NO. MPD 47.135(R)

---

---

*Grumman*

---

NO OTS

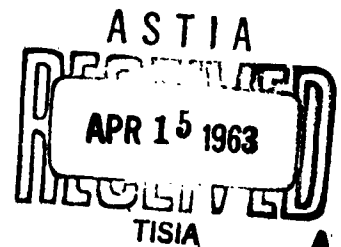

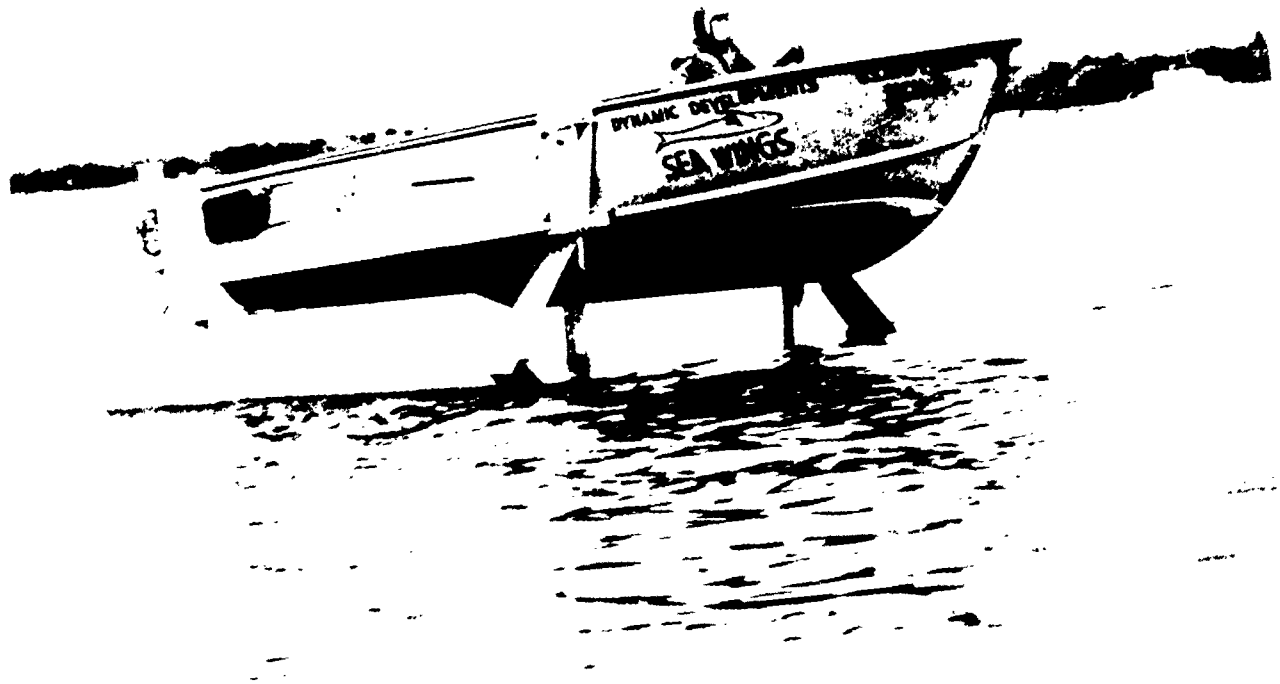

DEVELOPMENT AND TESTING OF MOTION  
MEASURING INSTRUMENTATION FOR THE  
XCH-6 HYDROFOIL CRAFT

Prepared For:

Office of Naval Research  
Washington 25, D.C.  
Under Contract NONr 2695(00)

Prepared by: W. C. Blaiklock

Checked by: R. C. Muncie

E. W. Ferris

R. M. Edgerly

Approved by: G. J. Wennagel

Chief Engineer, Marine Projects

Grumman Aircraft Engineering Corporation  
Bethpage, Long Island, New York

Report No. MPD 47.135(R)  
January 1963

TABLE OF CONTENTS

<u>Section</u>		<u>Page</u>
1	Summary	1
2	Introduction	2
3	Description of Test Vehicle and Instrumentation	3
4	Test Program	8
5	Data Processing	11
6	Test Results	13
7	Conclusions and Recommendations	15
<u>Appendix</u>		
A	References	A-1
B	Detailed Test Procedure	B-1

LIST OF ILLUSTRATIONSFigure

1. ONR XCH-6 Hydrofoil Craft - Profile
2. ONR XCH-6 Hydrofoil Craft - Front and Rear Views
3. ONR XCH-6 Hydrofoil Craft - Plan View
4. Data Flow Diagram
5. Altimeter Transducer
6. Splashnik Sea State Buoy and Damping Vane
7. XCH-6 Instrumentation Package Block Diagram
8. Receiving Station Block Diagram
9. Receiving Station
10. Tail Strut Camera Setup
11. Data Processing Block Diagram
12. Typical Time History Tape
13. Frequency-Amplitude Spectra, Test No. 3
14. Frequency-Amplitude Spectra, Test No. 5 (Head Seas)
15. Frequency-Amplitude Spectra, Test No. 5 (Following Seas)
16. Computed Sea State Spectra, Test No. 5
17. Splashnik Sea State Spectra, Test No. 5

SECTION 1. SUMMARY

An instrumentation system has been developed to measure the motions in a seaway of the XCH-6 hydrofoil craft. Each parameter is detected by a transducer, and the data are transmitted to a receiving station by an FM/FM telemetry link. Data are recorded in the receiving station on magnetic tape.

During this development, a test program was carried out on Long Island Sound. Machine analyses of portions of the resulting data were made to obtain frequency-amplitude spectra of pitch, roll, and heave parameters. In addition, the sea state at the craft was computed by means of analog computer operations on tail strut altitude and acceleration. The sea state was also recorded by a "Splashnik" sea state buoy. Examples of each of these spectra are presented.

It was found that distortions were introduced into the spectra by the broad band noise of the system electronics. Methods of reducing such distortion are discussed, and recommendations for the improvement of the system are made.

## SECTION 2. INTRODUCTION

The XCH-6 hydrofoil program was begun in 1958 under Contract NOnr 2695(00). The program has resulted in the development of a hydrofoil craft, the XCH-6, using ventilated main foils and a supercavitating propeller. A detailed description of the program and previously obtained results are contained in Appendix A, References 1 and 2.

Reference 1 describes the building and initial testing of the XCH-6, as well as the marinization of the gas turbine. Open water supercavitating propeller tests performed subsequently are described in Reference 2.

This report covers the development and testing of an instrumentation system to measure hydrofoil craft motions. The system measures, transmits and records six parameters defining the craft motions in a seaway. Using machine analysis, the energy and/or amplitude versus frequency spectra of each parameter, and of the sea state may be obtained.

During the program, tests were run in several sea states to check the instrumentation system. A Splashnik sea state buoy was employed in an effort to obtain a check on the calculated sea state. Portions of the data obtained were spectrum analyzed, and results are presented in this report.

### SECTION 3. DESCRIPTION OF TEST VEHICLE AND INSTRUMENTATION

#### Test Vehicle

The XCH-6 hydrofoil craft is shown in Figures 1 through 3, and described in detail in Reference 1. The vehicle has a 23-foot aluminum hull, supported by two surface piercing ventilated main foils and a fully submerged subcavitating tail foil. The vehicle is powered by a General Electric T-58 gas turbine driving a supercavitating propeller through a right-angle drive.

In order to carry out the motion study program, several modifications to the XCH-6 were made. A 20-gallon fuel tank was installed to permit operation for approximately 40 minutes without refueling. A battery bracket was installed to enable the boat systems battery to be changed at sea. Finally, the altimeter and instrumentation package were installed, as described below.

During this program, the fully loaded vehicle weight was 2902 lbs., with the L.C.G. located at hull station 135.5. Thus, 76.2 percent of the weight was carried on the main foils, and 24.8 percent on the tail foil.

#### Instrumentation

The data acquisition system selected was dictated by the type of data processing employed, and by weight and space considerations in the test vehicle. The data processing and recording equipment utilize magnetic tape. To reduce the weight of instrumentation carried in the test vehicle, the data were transmitted to a shore based receiving station and recorded.

A block diagram of the instrumentation system is shown in Figure 4.

The following parameters were transmitted, recorded and processed:

- Craft Pitch Angle
- Craft Roll Angle
- Stern Strut Normal Acceleration
- Craft C.G. Heave Acceleration
- Craft Speed
- Stern Strut Immersion (Altimeter)
- Sea State (Splashnik)

These measurements are discussed below.

Pitch and Roll: Craft pitch and roll angles are sensed by a Minneapolis-Honeywell Vertical Gyro (P/N JG 7044-A4). This is a cageable gyro with automatic erection and a full scale range of  $\pm 19.5$  degrees in both axes. The gyro gimbal pickoffs are potentiometers.

The gyro is installed in the craft with its base parallel in both axes to the hull reference axes.

Acceleration: Stern strut and C.G. normal accelerations are sensed by Donner Servo Accelerometers, Models 4310A and 4310.

Speed: Craft speed is measured using a Statham pressure transducer, Model P183-75A-350, which senses water ram total pressure. This is a Wheatstone bridge transducer with a range of 0 to 75 psia. The transducer is connected to the existing craft ram pressure line, which runs to an orifice in the nose of the tail pod.

Both the accelerometers and the gyros were calibrated using a standard tilt table. The pressure transducer was calibrated by means of a dead weight tester.

Strut Immersion: The craft stern strut immersion, or altitude, is measured by a resistance contact device. The altimeter sensor, shown in Figure 5, consists of contacts mounted on, and insulated from, the tail strut leading edge. These contacts are spaced at 1-inch intervals, and cover a total range of 18 inches. A ground plate is mounted on the lower portion of the strut. The altimeter senses the shorts between the contacts and the ground plate which are created as the strut is immersed. The altimeter output signal is a stepped d-c voltage, increasing in magnitude as the strut is immersed. Prior to actual use the altimeter was calibrated by shorting between the contacts and ground plate with 290-ohm resistors per short. The value of 290 ohms was selected as representative of the resistivity of salt water. The calibration was performed to determine the altimeter output characteristics, which were acceptable.

In practice the resistance of the water varies from the nominal 290 ohms. To determine the actual sensitivity, the altimeter output is recorded before launching the boat, and again on reaching the test site, with all contacts immersed.

A detailed description of the altimeter may be found in Reference 3.

Sea State: In addition to calculating the sea state from boat motion data, a D.T.M.B. Splashnik buoy was employed to measure sea state directly (see Reference 4). The Splashnik is a self-contained accelerometer, sensitive to normal accelerations and to angle of inclination. The accelerometer is housed in a float which contours the waves. Acceleration signals are transmitted directly from the Splashnik to the receiving station.

When using the Splashnik in relatively short, steep, waves, such as were encountered during the program, excessive tilting of the float results in false acceleration signals. To prevent this, a damper was fabricated consisting of an aluminum tube with two large vanes attached. The damper extends down into the water about 10 feet, and virtually eliminates tilt, but leaves the float free to respond in heave. The Splashnik and damper are shown in Figure 6.

#### Data Transmission

The telemetry system used in the XCH-6 is a standard FM/FM system utilizing six subcarrier channels for data transmission. The package occupies approximately  $\frac{1}{2}$  cu. ft. of space and weighs 25 pounds. It is completely self-contained; the only external connections are for input signals from transducers, + 28-volt d-c power, and the radio frequency output to the boat antenna. A block diagram of the instrumentation package is shown in Figure 7.

The FM transmitter used is a Bendix TXV-13. It is crystal controlled and operates in the 215 to 260 megacycle telemetry band with a nominal output power of 2 watts. The transmitter antenna is a horizontally polarized "wheel" antenna, which provides an omnidirectional radiation pattern.

A number of d-c and a-c voltages are needed to power the different components in the package. Two solid state converters are used. One is an Arnold Model which generates + 150-volts d-c from the 28-volt input source, and is used to supply plate voltage for the r-f transmitter. The second, a Transpak Model IT 21S4A, provides 115-volts, 400-cycle a-c with a 28-volt d-c input.

This 115-volt source is used to power the vertical gyro and is also stepped down to 26-volts a-c required for gyro erection. The various low level d-c voltages required for power and calibration are derived directly from the 28-volt input by means of Zener regulators and precision resistive divider networks.

Two types of subcarrier oscillators are used in the package. Both are manufactured by Data Control Systems, Inc., and are solid state units. The Model AOV-3 oscillator requires 0 to 5 volts for full deviation, and the Model AOV-10 requires an input signal of plus or minus 10 millivolts. A Grumman designed amplifier combines the oscillator outputs and feeds this subcarrier complex to the r-f transmitter.

The input to the vertical gyro roll potentiometer is a regulated 20-volts d-c. For a roll attitude of +5 to -5 degrees, the output voltage changes from 12.5 to 7.5 volts. In order to utilize a 0-to-5-volt subcarrier oscillator, a battery is used to apply a -7.5 volt bias voltage to the potentiometer output. The pitch potentiometer is wired in a similar manner except that 16 volts is applied. This gives an output range of 11.2 to 6.8 volts for pitch angles from +8 to -3 degrees. A bias voltage of 6.8 volts is used to change this to a range of 0 to 5 volts at the oscillator input.

The outputs of the Donner accelerometers are such that they may be fed directly into the 0-to-5-volt oscillators.

The altimeter output is a stepped voltage with a total range of 5 volts d-c for eighteen contacts immersed. In order to function properly, the altimeter output must be completely isolated from ground. This requires the use of a subcarrier oscillator with a differential input. For this purpose, an AOV-10 oscillator is used with a voltage divider connected to the altimeter output. The voltage divider reduces the 5-volt output to 10 millivolts required by the oscillator.

The water speed pressure transducer has an output in the millivolt range. The output is conditioned using a gain and balance unit, and then modulates an AOV-10 subcarrier oscillator.

To assure maximum possible data accuracy, the telemetry package contains an internal calibration system. During the calibration cycle the transducers, with the exception of water pressure, are disconnected and accurate reference voltage simulate their output signals. The water pressure transducer is calibrated by inserting an accurate series resistance. The corresponding unbalance value (resistance calibration equivalent value) is obtained from the transducer calibration plot. The calibration is applied to all data channels in the form of zero and full-scale voltages. The cycle is controlled manually and is actuated before and after each run.

#### Receiving Station

The receiving station, shown in Figures 8 and 9, handles two r-f signals: the Splashnik signal, and the output from the telemetry package on the XCH-6. A Nems-Clark Model 1671 Receiver was modified to monitor the discriminator output. This d-c output voltage varies as the received r-f carrier from the Splashnik varies, and is used to modulate a voltage controlled oscillator. The oscillator output is then recorded on magnetic tape.

When the receiver is tuned to the craft frequency, the wide band output containing the subcarrier complex wave is recorded. The original antenna installation employed vertical whip antennas for both transmission and reception of craft data. In order to extend the operating range without increasing transmitter power output, a high gain receiving antenna was substituted. This antenna is a 15-element Yagi which provides a gain of approximately 16 db at the operating frequency. The narrow beam width of this horizontally polarized antenna necessitated a means of rotating it in order to track the craft.

Both the Splashnik and craft outputs are mixed with a 17-kc signal at the tape recorder. This 17-kc signal provides a reference frequency that is used for tape speed variation compensation when the tape is played back for data reduction.

#### SECTION 4. TEST PROGRAM

The instrumentation system has been tested in several sea states. Initial tests were made in Oyster Bay, and were followed by rough water tests in Long Island Sound, off Bayville, New York. In this region the Sound is approximately 5 miles wide. Thus, test runs along a north-south course are limited to about 3 miles. In an east-west direction, there is practically unlimited sea room, but the run length is limited by the range of the telemetry.

It was desired to run in wave heights of 6 to 18 inches. Along the east-west axis of the Sound in the test area, waves are generally either the result of light westerlies and are less than 6-inches high or are the result of strong northeast winds which produce 3 to 4 foot waves. It was found that waves of the required size were most often produced by winds from the north and north-west. Since this is across the Sound, the data runs required nearly the total distance available. Thus, significant changes in the sea state may be expected along the length of the run. Furthermore, there was usually either a decay or buildup of the sea during the course of a test. Hence, no attempt was made to test in a "fully developed" sea.

The first test run was made in Oyster Bay Harbor on August 27, 1962. At this time the instrumentation was completely installed, with the exception of the altimeter. The purpose of the test was to check out the instrumentation package in smooth water. Inspection of the data showed that the instrumentation was operating correctly.

The next run was made in the same area to test the altimeter. It was found that the altimeter output was approximately 1 volt, rather than the expected 5 volts. Modification to the instrumentation package and further testing were required to correct this condition.

The first run in Long Island Sound was made in waves averaging 6-inches high, running northwest to southeast. Runs were made in head and following seas at 52 and 42 mph, as well as in head seas at 35 mph. An inspection of the data time history indicated that the instrumentation was functioning properly. However, the range of the telemetry transmitter was less than expected, and many of the data were unsuitable for machine analysis because of signal dropout.

The final test was made in the Sound running north to south in wave heights of 12 to 15 inches. Runs were made in head and following seas at 52, 40, and 35 mph. No unusual difficulties were encountered. A new antenna system increased the telemetry range to at least 7 miles, and much more of the data were useable.

During the initial testing, motion pictures were made of the water flow over the tail strut altimeter. The camera setup is shown in Figure 10. The pictures indicated that no spray from the main foils was impinging on the strut, and that the altimeter was correctly indicating the tail strut immersion.

Certain difficulties were encountered in running the XCH-6 in a seaway. It is not possible to hold the vehicle speed absolutely constant, and variations of plus or minus 3 to 5 miles per hour must be expected.

In some sea states the range of the altimeter transducer was frequently exceeded, resulting in "clipping" of the altimeter trace.

A third difficulty was caused by the limited size of the test area. While data sample lengths of 225 seconds were desirable, it was seldom possible within available sea room to make steady state runs longer than 150 to 180 seconds.

A summary of the test program is given in Table I. Appendix B gives details of the test procedures used.

TABLE I  
TEST SUMMARY

Test No.	Date	Test Location	Wind/Sea	Courses & Speeds	Purpose of Test	Type Data Reduction Performed	Remarks
1.	3-27-62	Oyster Bay Harbor	Calm	Various	Check out instrumentation	Time history	The altimeter was not installed at this time.
2.	10-3-62	Oyster Bay Harbor	Light Westerly 2 - 4" ripples	Various	Check out altimeter	Time history	A film of the altimeter contacts was made. The instrumentation package and altimeter functioned correctly.
3.	10-24-62	Long Island Sound off Bayville	Calm 6 - 8" from NW	NW-SW 52, 42 mph SE-NW 52, 42 mph	Data runs	Time history, spectrum analysis of some portions	A second film of the altimeter was made. Parts of the data were lost due to short telemetry range.
4.	11-2-62	Long Island Sound off Bayville	Calm	None	Test new antenna system	None	Antenna test satisfactory. Telemetry range increased.
5.	11-12-62	Long Island Sound off Cold Spring Harbor	North 10 mph 12 - 15" from N	N - S 52, 40, 35 mph S - N 52, 40, 35 mph	Data run	Time history, spectrum analysis of selected samples	Final test

SECTION 5. DATA PROCESSING

As a necessary expedient to analysis, the data were assumed, over the sampling period, to approach stationary random processes. This assumption permitted simplification of the power density determination by eliminating the integrations which would be necessary with data whose individual components follow different amplitude profiles with time.

The equipment employed to process the test data is outlined in Figure 11. The original tape, recorded at a 15-ips tape speed, is demodulated for both oscillograph readout and wide band modulation of a second tape recorder, operating at 1-7/8 ips. Compensation techniques are utilized on both the original and transcribed tape, to reduce the effects of tape speed perturbations. Only selected areas of the original test tape are transcribed for formation into a tape loop. In order to reduce the analysis time, an effective data frequency multiplication of 32 is obtained by running the loop at a tape speed of 60 ips. After demodulation the signals are either spectrum analyzed directly, or subjected to analog computer operations prior to analysis.

The analog computer is used as a means of calculating the sea state, by double integrating the tail strut acceleration and subtracting this from the altimeter trace. The resulting wave profile is then spectrum analyzed.

Several problems were encountered during the data processing. The first of these was due to the signal dropouts noted previously. The effect on the data is to produce noise signals wherever the dropouts occur. Such noise signals are of higher amplitude than the data signal, and thus produce severe distortion in the spectra. For this reason, data samples containing no signal dropout were selected for analysis.

Two other difficulties were caused by the characteristics of the instrumentation package and of the test vehicle. The predominant motions of the XCH-6 occur in the region around 1 cps. For lower frequencies, in the order of 0.3 cps and below, the amplitudes of the motions are relatively small, and the resulting signal levels approach the ambient noise level of the recording and data processing system.

The signal level problem was aggravated by the fixed gain characteristic of the instrumentation package. The range of each transducer is fixed by the maximum amplitudes encountered during testing. Therefore, the low amplitude motions produced by small waves result in a low signal level throughout the entire spectrum.

For these reasons the lower limit of spectrum analysis was fixed at 0.3 cps.

The altimeter signal, used in the sea state computation, contained signal discontinuities (clipping) due to insufficient length of the altimeter transducer. These discontinuities are quite obvious in Figure 12.

The effect of such discontinuities is to introduce bogus high frequency motions into the spectra. Additional distortions of the computed sea state result from the summing of noise and data signals in double integrating the tail strut accelerometer signal.

## SECTION 6. TEST RESULTS

### Time Histories

The first step in processing is to print out the data just as it was recorded, on oscillograph paper. This provides a time history of data for the entire run, from which samples are selected for further processing. A portion of a typical time history is shown in Figure 12.

### Frequency Amplitude Spectra

Figures 13 through 15 show selected energy spectra for three test runs on Long Island Sound. The amplitudes of these spectra are plotted in decibels.\* The calibration level for each parameter is equal to the resistance calibration equivalent value built into the instrumentation package.

The frequency intervals at which the spectra were analyzed are as follows:

<u>Range</u> (cps)	<u>Interval</u> (cps)
0.31 - 0.63	0.156
0.63 - 1.25	0.313
1.25 - 3.13	0.616
3.13 - 6.26	1.56
6.26 - 10.00	3.13

The apparently strange choice of intervals is the result of performing the analysis in 32 times "real time".

Because of the signal-to-noise ratio problem already discussed, each spectrum contains noise distortion which becomes worse as the amplitude of the spectrum decreases. For this reason, portions of the spectra which are approximately more than 40 db below the calibration level are not valid.

### Sea State Computation

Some results of the sea state computation are shown in Figure 16. For comparison, Splashnik spectra made at the same time are shown in Figure 17. The Splashnik displacement spectra were obtained by double integration of the acceleration spectra.

\* Decibels used in this report are defined as:  $(20)\log_{10} \frac{\text{amplitude}}{\text{reference amplitude}}$

No amplitude calibration was made for either the sea state computation, or the integrated Splashnik spectrum. This considerably reduces the time required for data processing, but does not affect the shape of the spectrum obtained.

## SECTION 7. CONCLUSIONS AND RECOMMENDATIONS

### Instrumentation and Data Processing

The present instrumentation package is somewhat inflexible, due to its fixed gain characteristics. An improved package would incorporate gain variation in each channel, to provide adjustment to a particular sea state. Such adjustments will result in an improved signal-to-noise ratio, and permit extension of the analysis to lower frequencies.

Performing the double integration process on transmitted data introduces distortion due to the summing of noise signals with the data signal. It is recommended that the required integrations be performed prior to transmission, within the instrumentation package. This recommendation also applies to the Splashnik or other sea state measuring device.

An improvement in the computed sea state can be made by adding more contacts to extend the range of the altimeter transducer and thereby improve its resolution.

### Sea State Computation

No comparison of the computed sea state with the Splashnik spectrum is possible on the basis of the limited data obtained. Implementation of the aforementioned improvements would aid materially in performing this comparison.

It is at least questionable whether the Splashnik sea state buoy provides an adequate standard for such a comparison. The mass and size of any float device limits the frequency to which it can respond. In this case, Reference 4 states that the Splashnik should not be used to measure frequencies higher than 1 cps. This leaves a significant portion of the spectrum unchecked.

A second difficulty is the tendency of the float to tilt on wave slopes and produce a false signal. While the damper already described appears to have solved this problem, no accurate measurement of the float inclination was made.

### Test Conditions

As already noted, no attempt was made to test in a "fully developed" wave pattern. As a practical matter, obtaining such a sea state in the particular test area would have been extremely difficult. Furthermore, there is some question as to whether such a condition is a desirable criterion for hydrofoil design. It is the exceptional circumstance and not the rule when a hydrofoil craft operates in a fully developed sea. Generally the sea state is in constant flux. Viewed from a stationary point of observation, the change may be relatively long term, or it may be a short duration change, as in sheltered waters. When viewed from a hydrofoil craft, any such change is accelerated by the craft velocity. Under such circumstances, the process may become non-stationary.

In system design, the character of the driving function used in computer analysis is important, and it is desirable to use the most realistic representation of the operating sea state for this purpose. One way of doing this is to utilize a direct recording of an actual sea way as the driving function for the analyses. However, restrictions on the length of recorded tapes frequently exclude some of the exceptional waves that the sea state is capable of producing, and one is restricted to repetition of the same tape. More diversity of sea state is available if various sea states can be constructed at will from a spectrum. For dynamic analysis, it is, therefore, more appealing to generate sea states from spectral characteristics of the operating conditions.

The most complete and consistent spectra available pertain to fully developed seas, which may be constructed as stationary processes. In view of the non-stationary nature of the normal operating environment a comparison is in order. Such a comparison must determine whether or not there is a substantial difference between stationary spectra and those measured in a state of flux.

This study does not purport to answer this question. It does, however, provide an initial assessment of the means for answering the question, and points to areas of improvement.

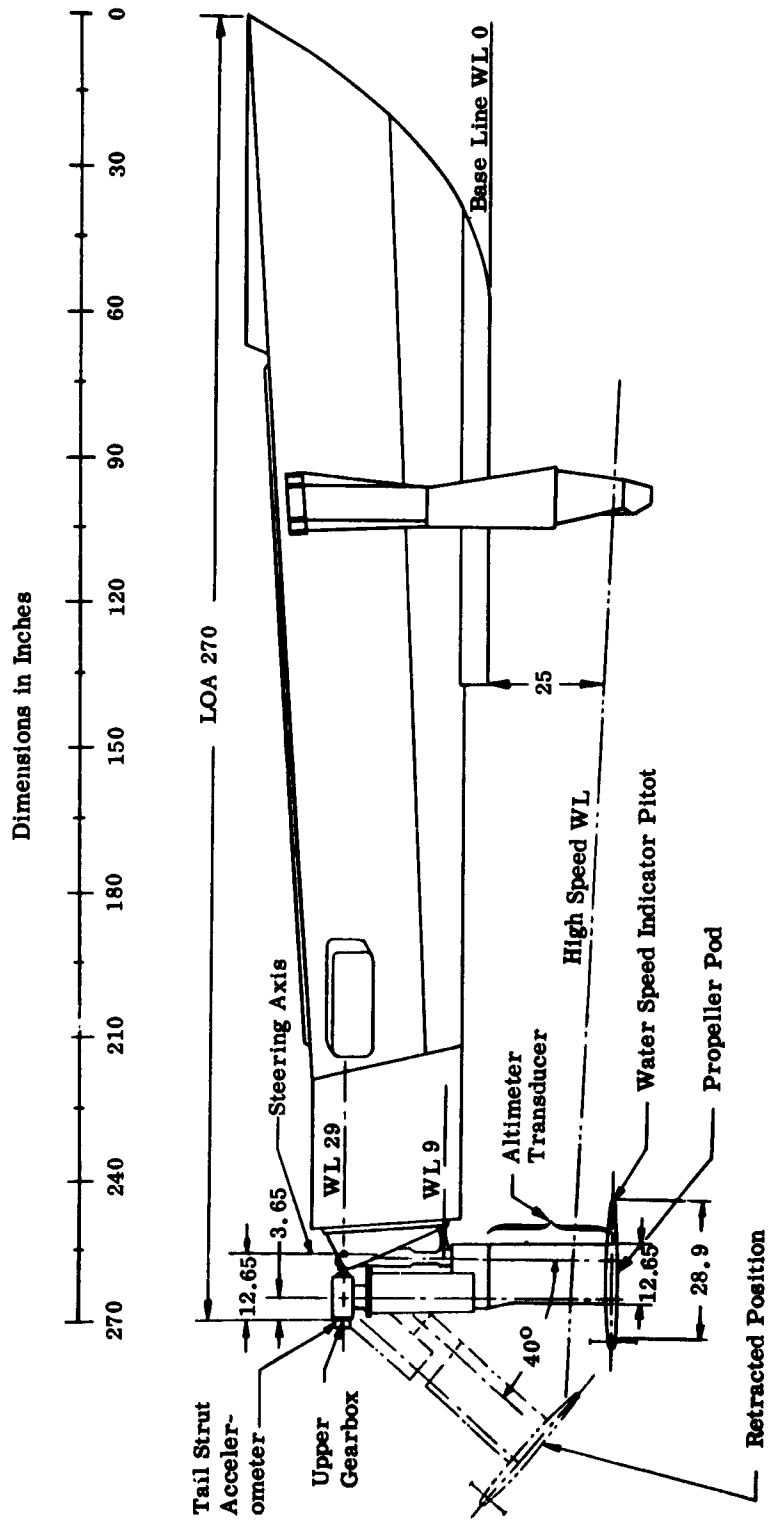

**Figure 1**  
**ONR XCH-6 HYDROFOIL CRAFT - PROFILE**

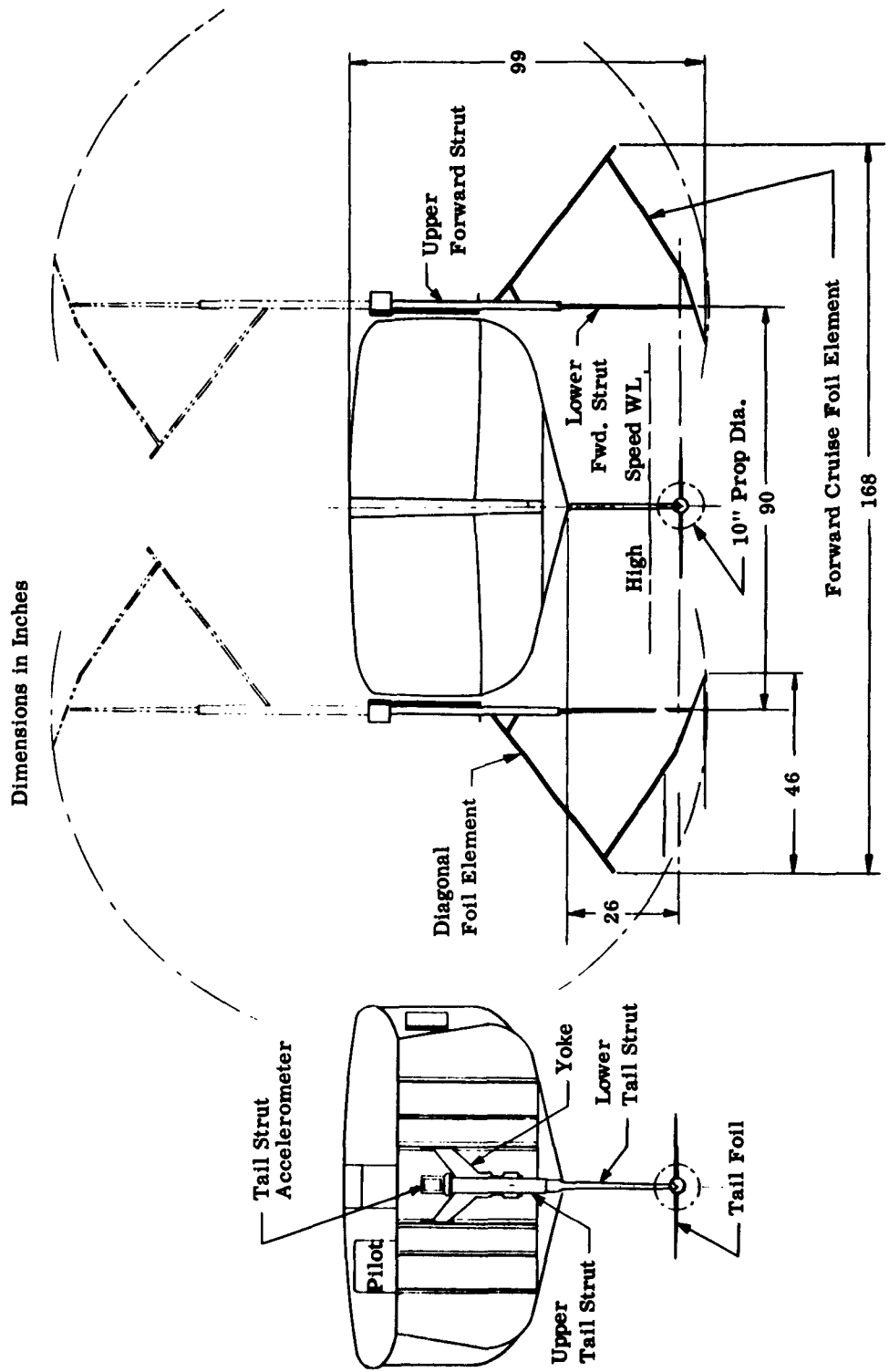

Figure 2  
ONR XCH-6 HYDROFOIL CRAFT - FRONT & REAR VIEWS

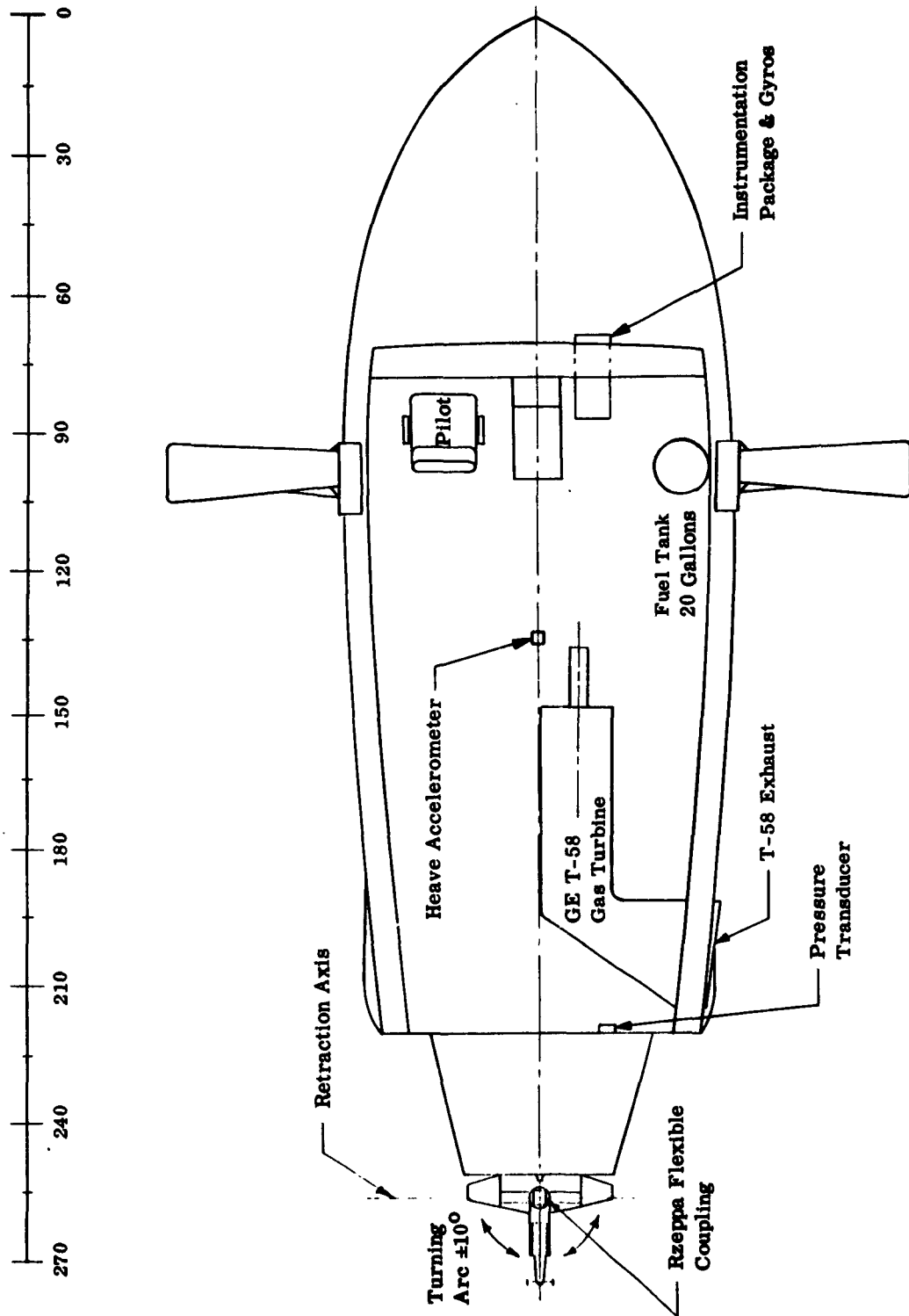

Figure 3  
ONR XCH-6 HYDROFOIL CRAFT - PLAN VIEW

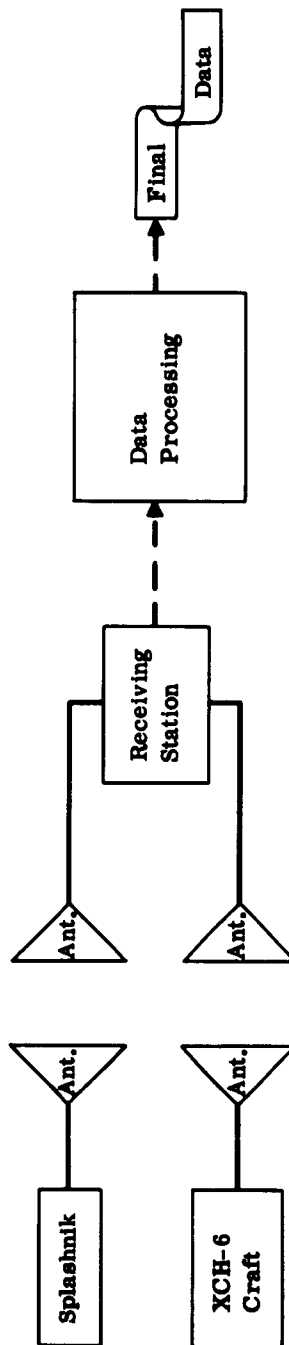

Figure 4  
DATA FLOW DIAGRAM



Figure 5  
ALTIMETER TRANSDUCER

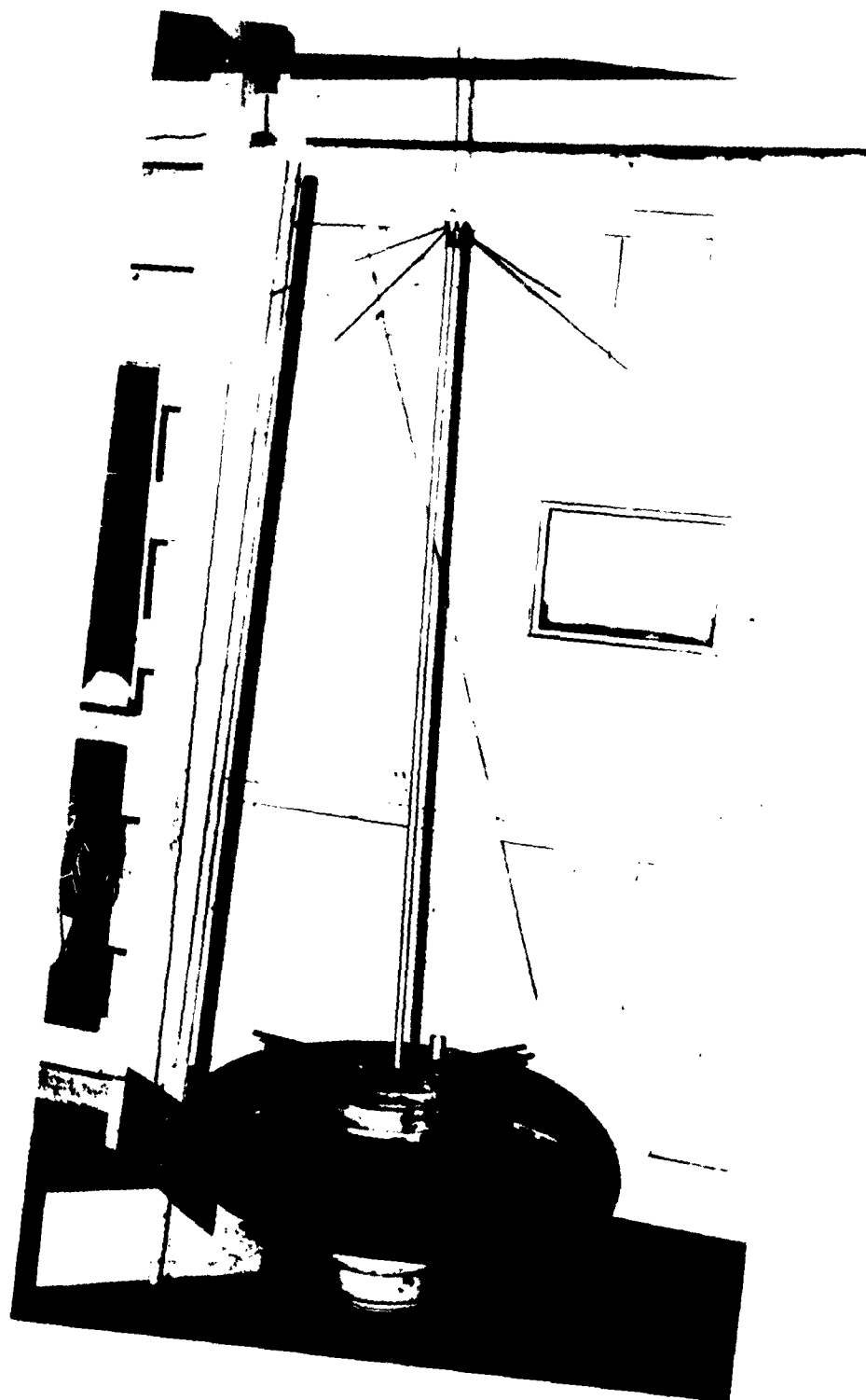

Figure 6  
SPLASHNIK SEA STATE BUOY AND DAMPING VANE

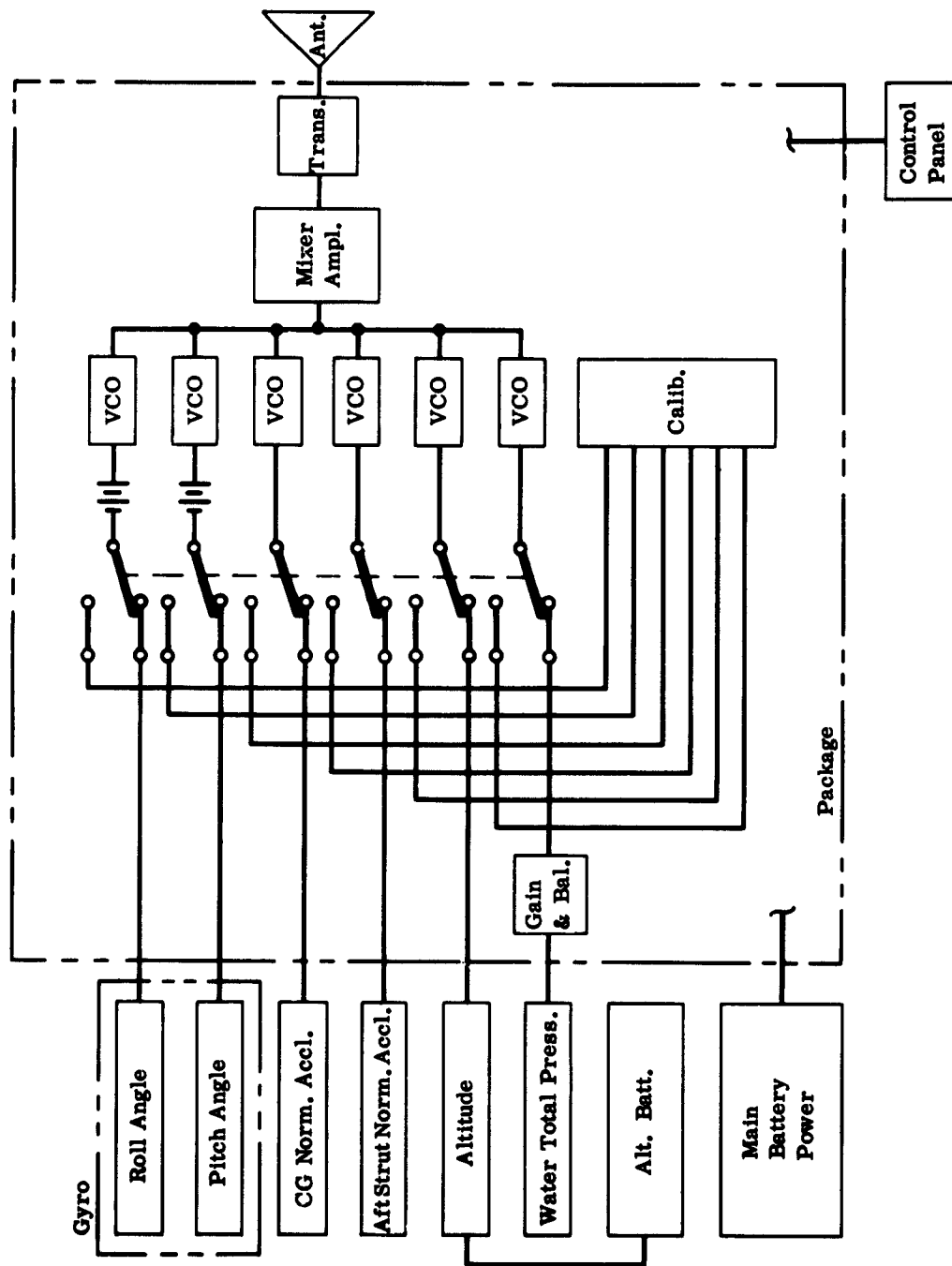

Figure 7  
XCH-6 INSTRUMENTATION PACKAGE BLOCK DIAGRAM

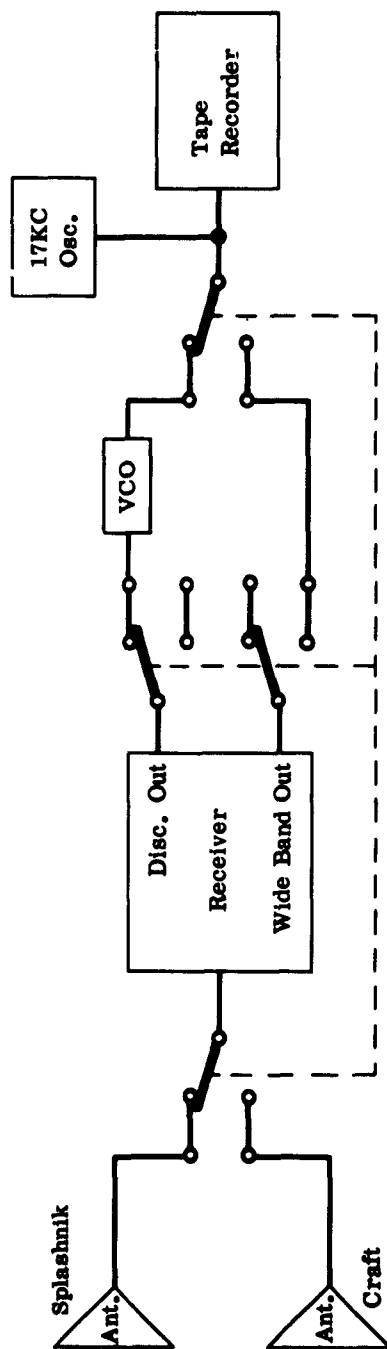

Figure 8  
RECEIVING STATION BLOCK DIAGRAM



Figure 9  
RECEIVING STATION



Figure 10  
TAIL STRUT CAMERA SETUP

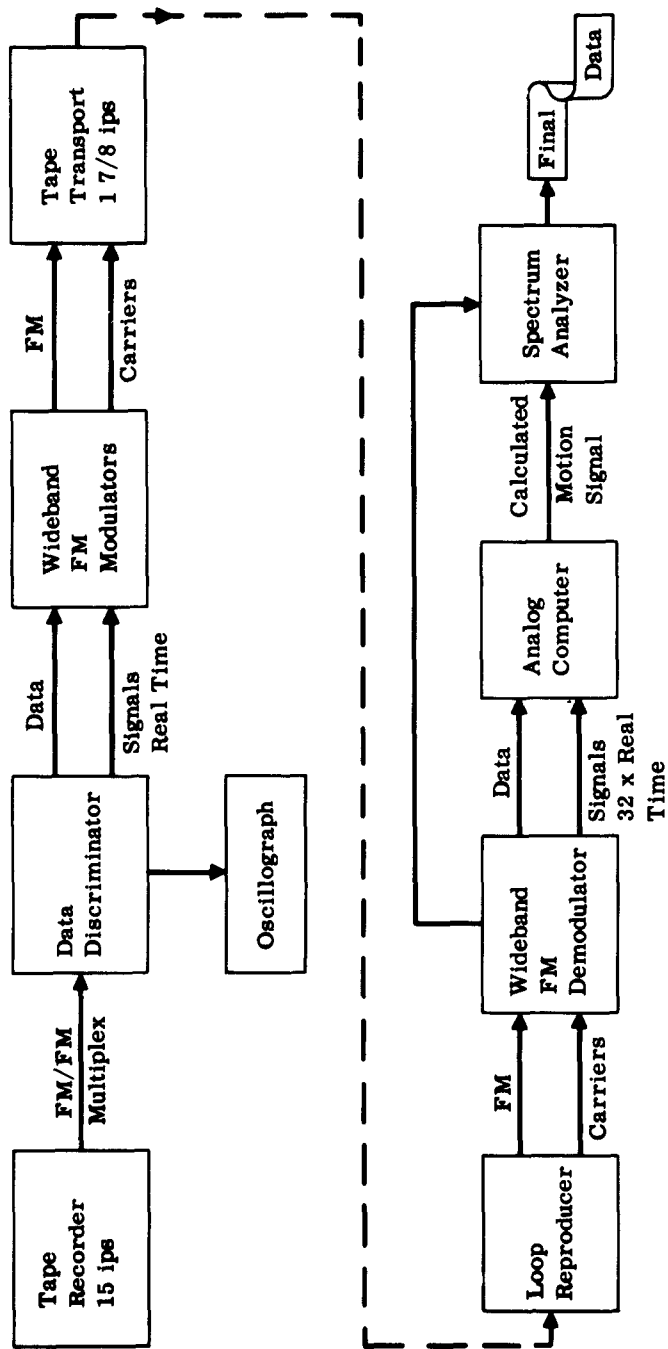
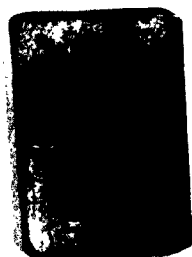
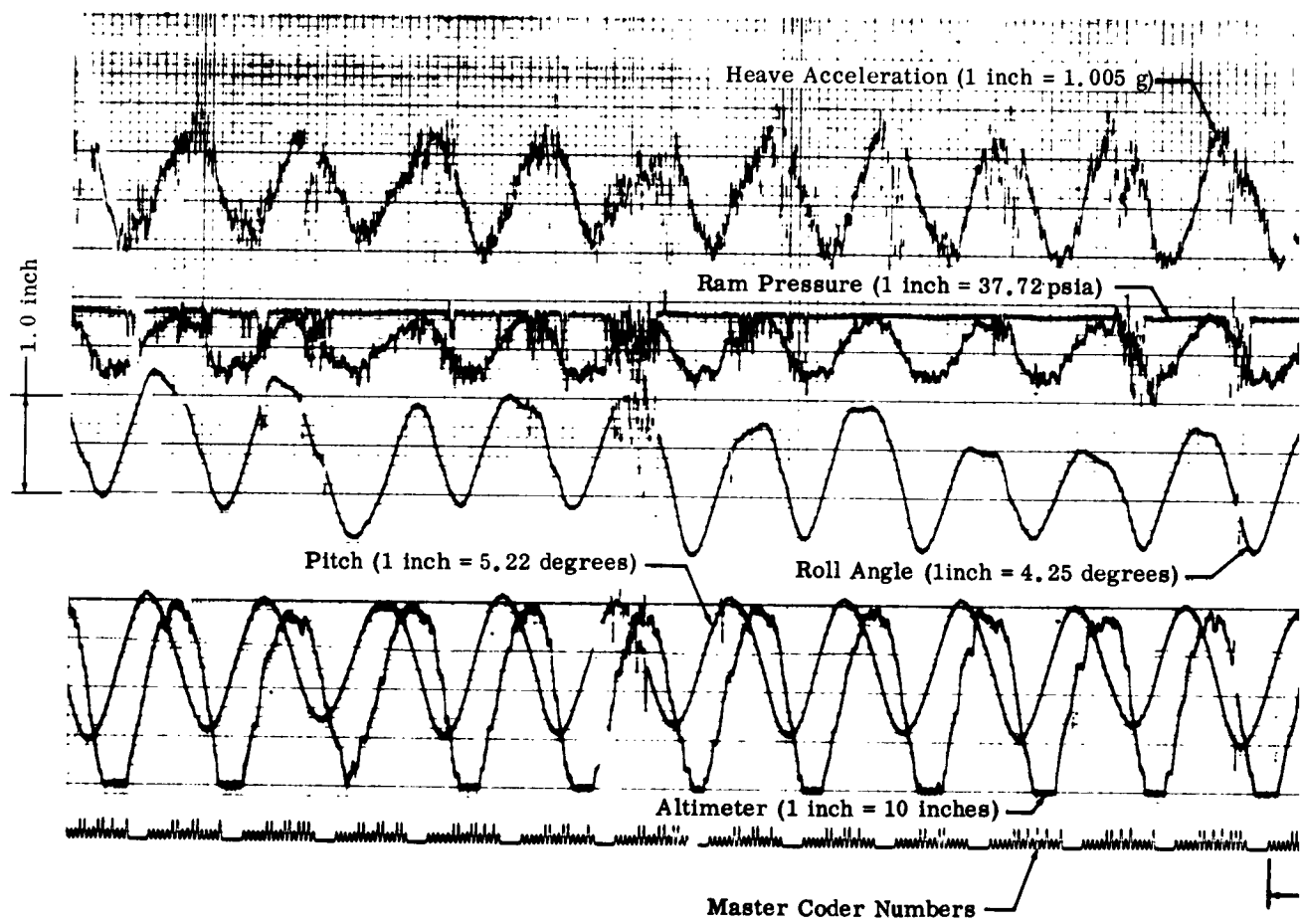
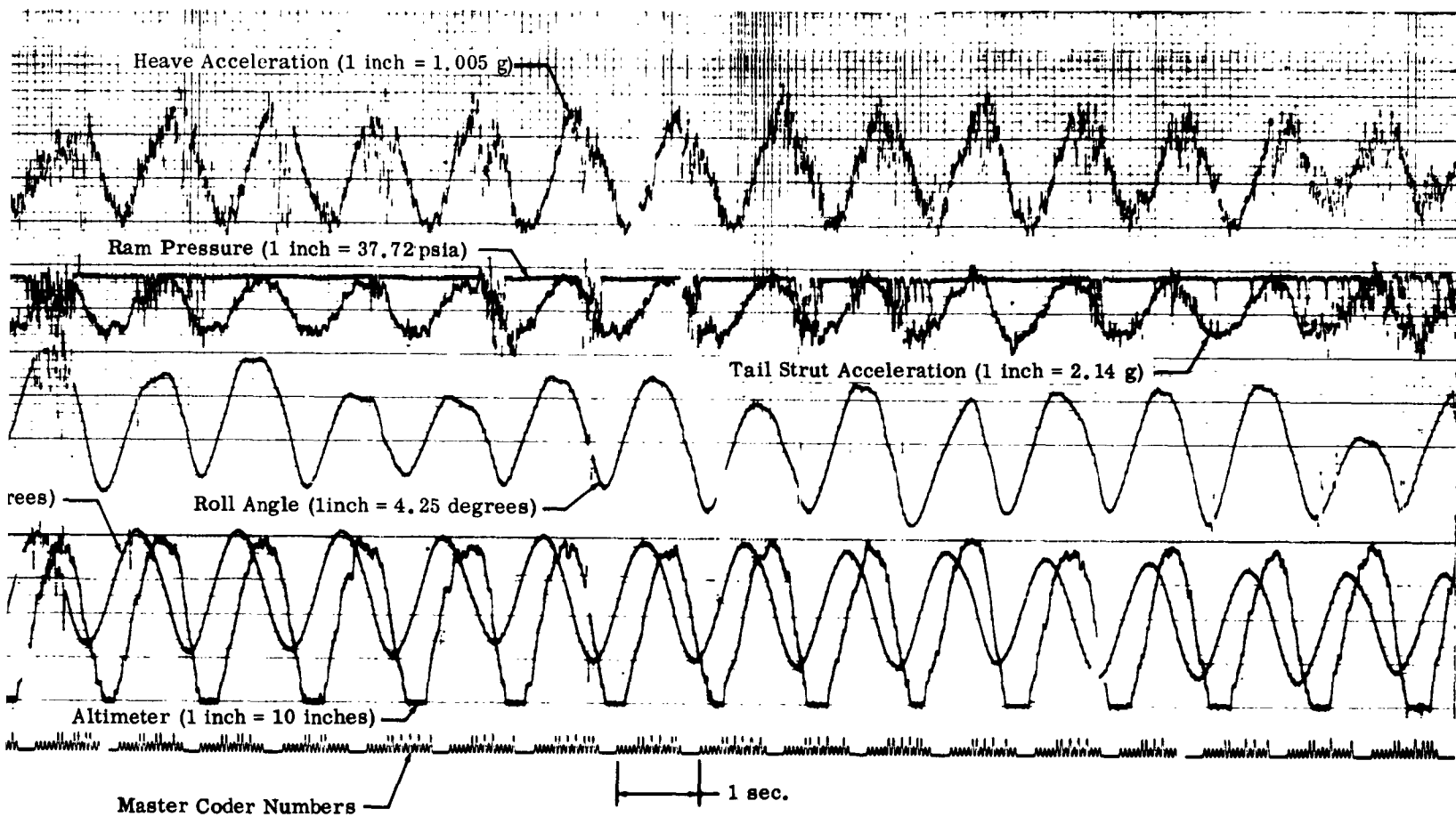

Figure 11  
DATA PROCESSING BLOCK DIAGRAM





**Note:**

All traces on this tape are positive upward. The positive direction represents upward accelerations, bow up pitch, starboard roll, increasing ram pressure, and decreasing altitude.

Figure 12  
TYPICAL TIME HISTORY TAPE



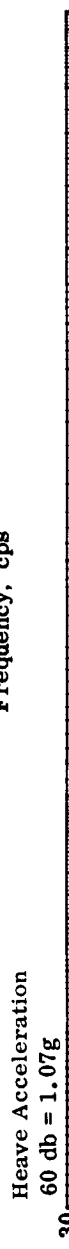
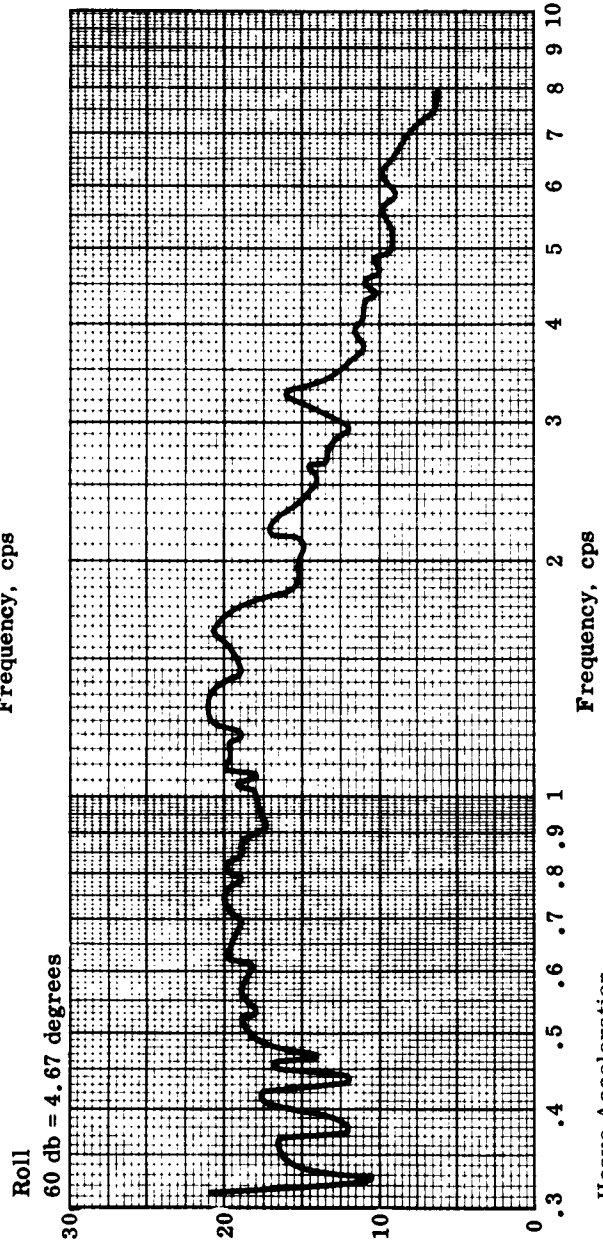
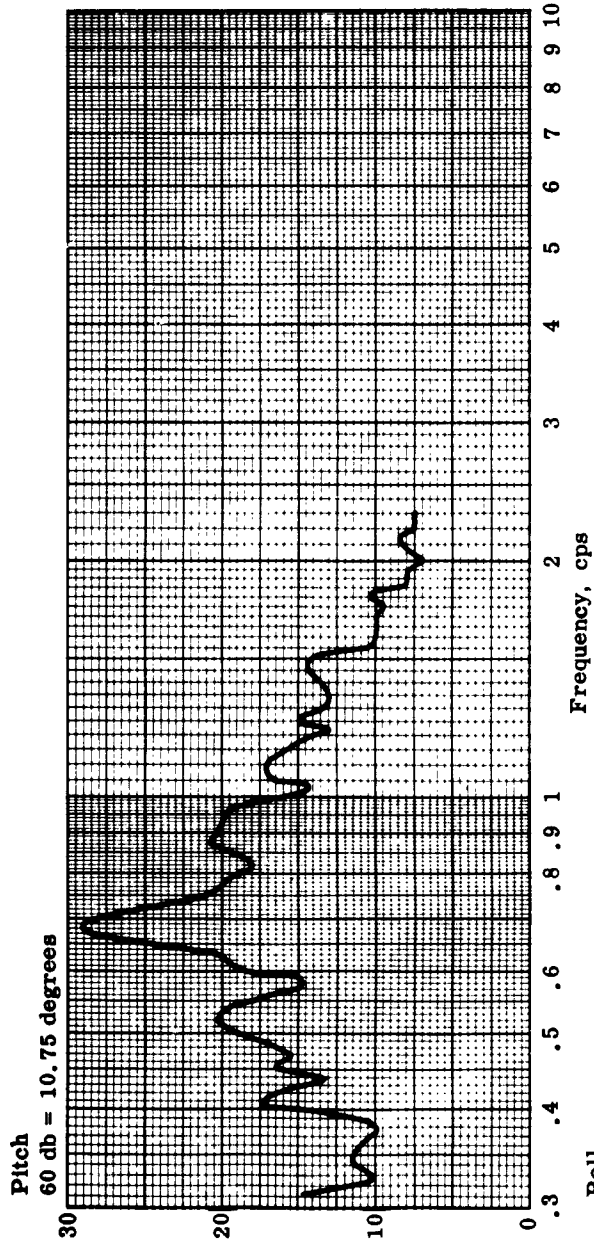

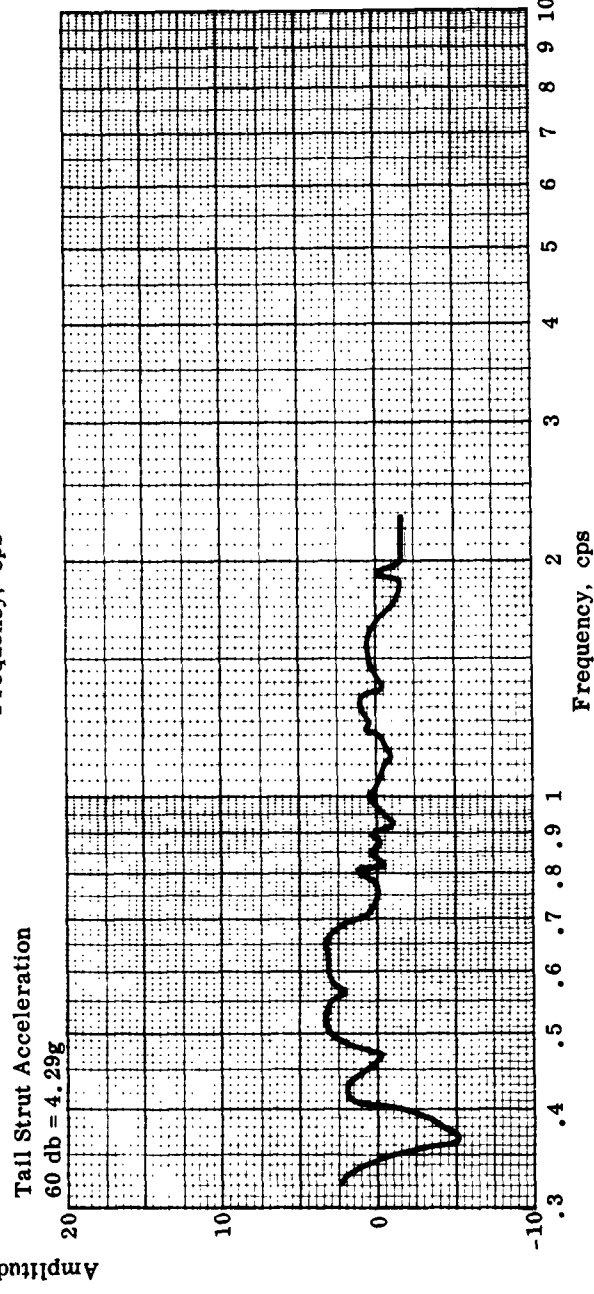
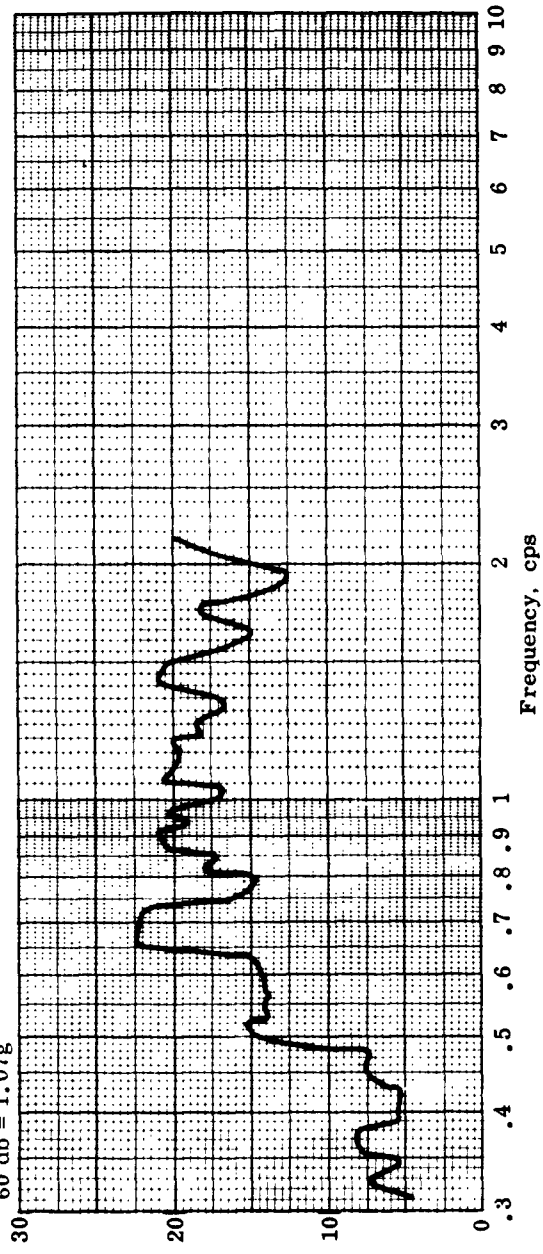
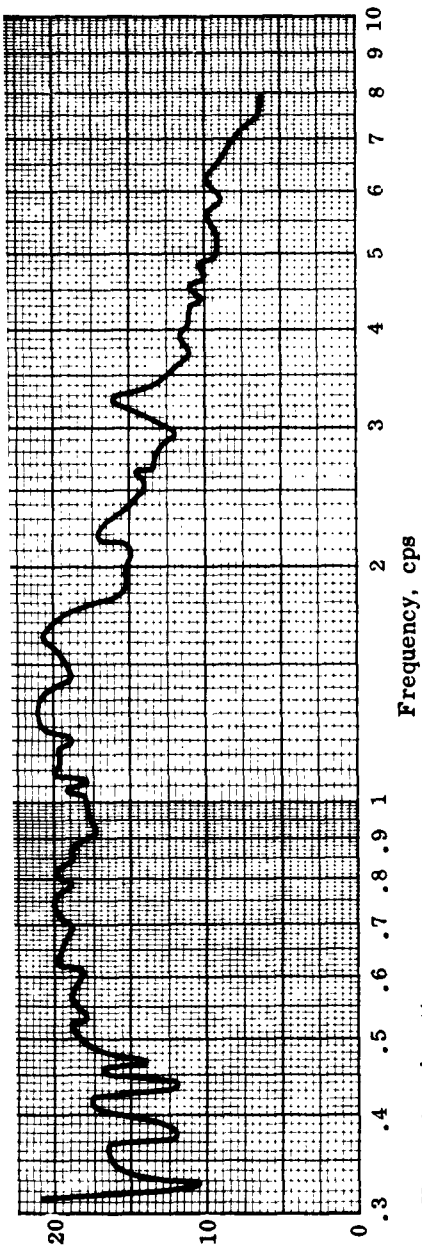

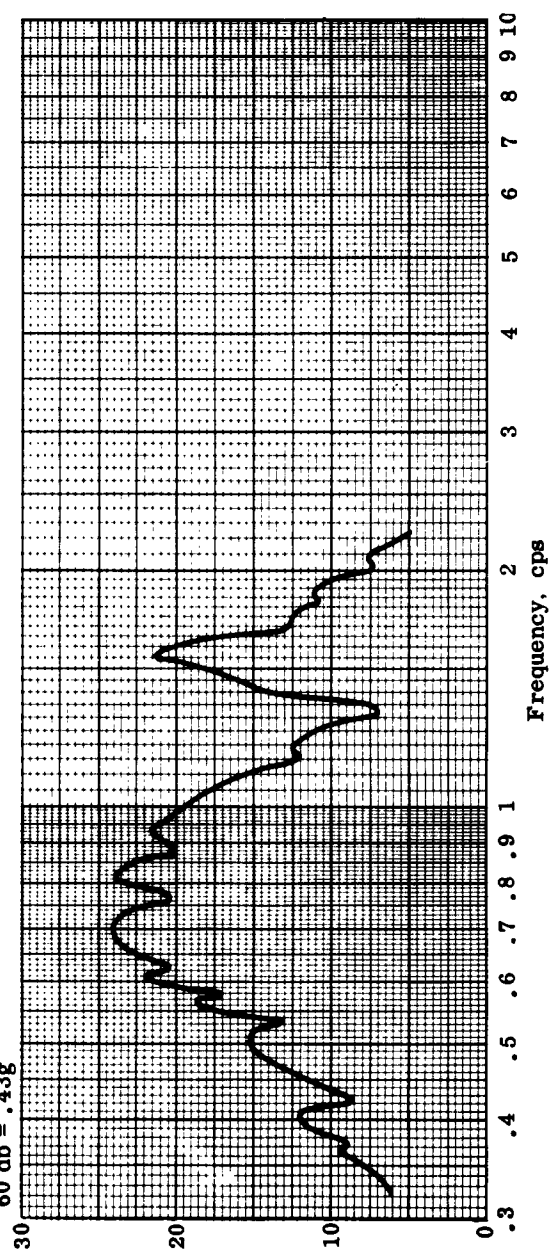
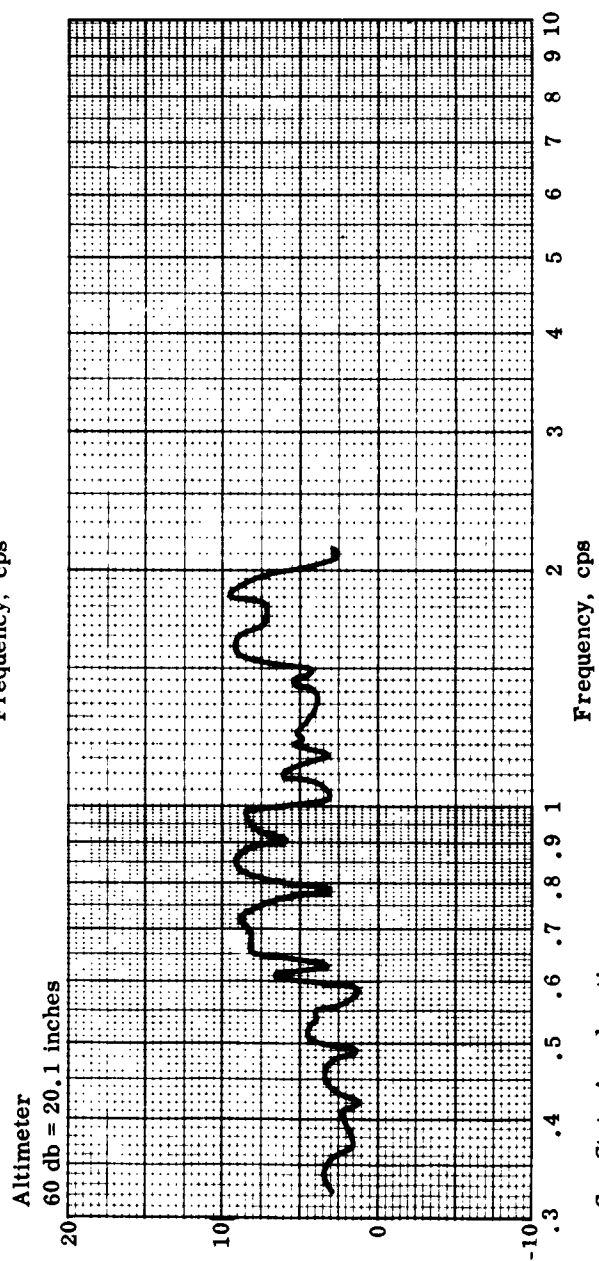
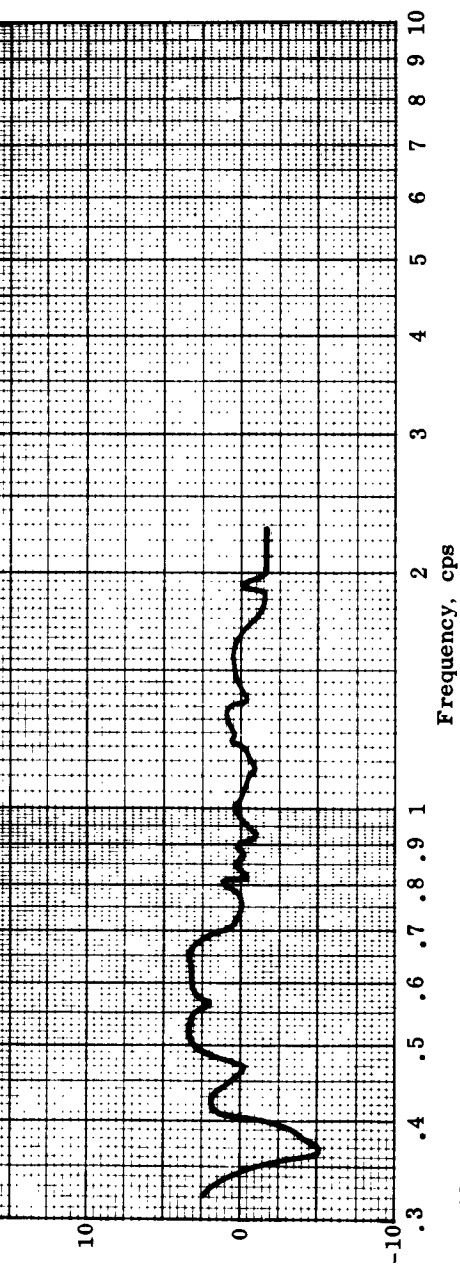
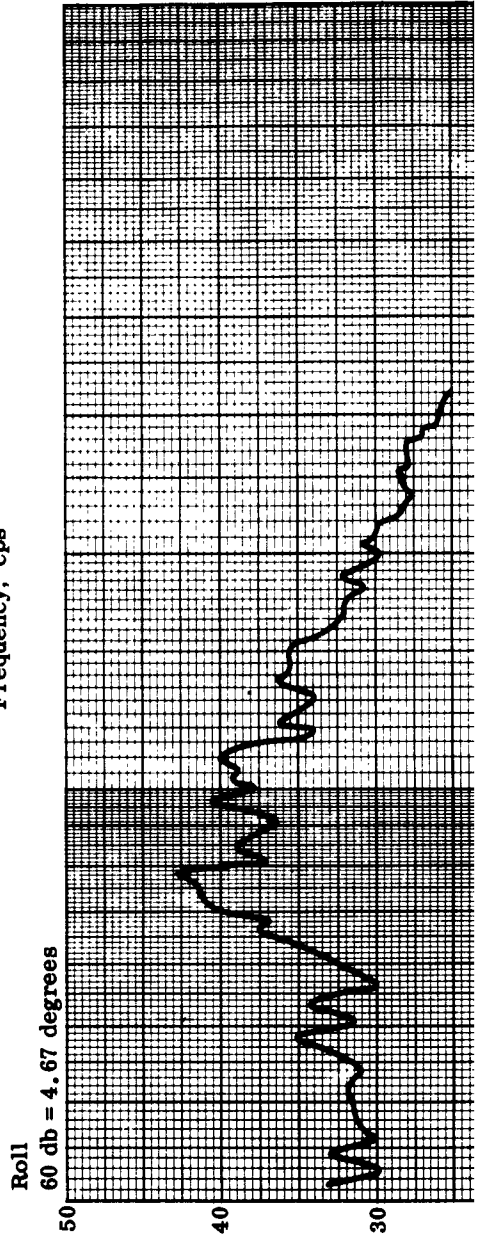
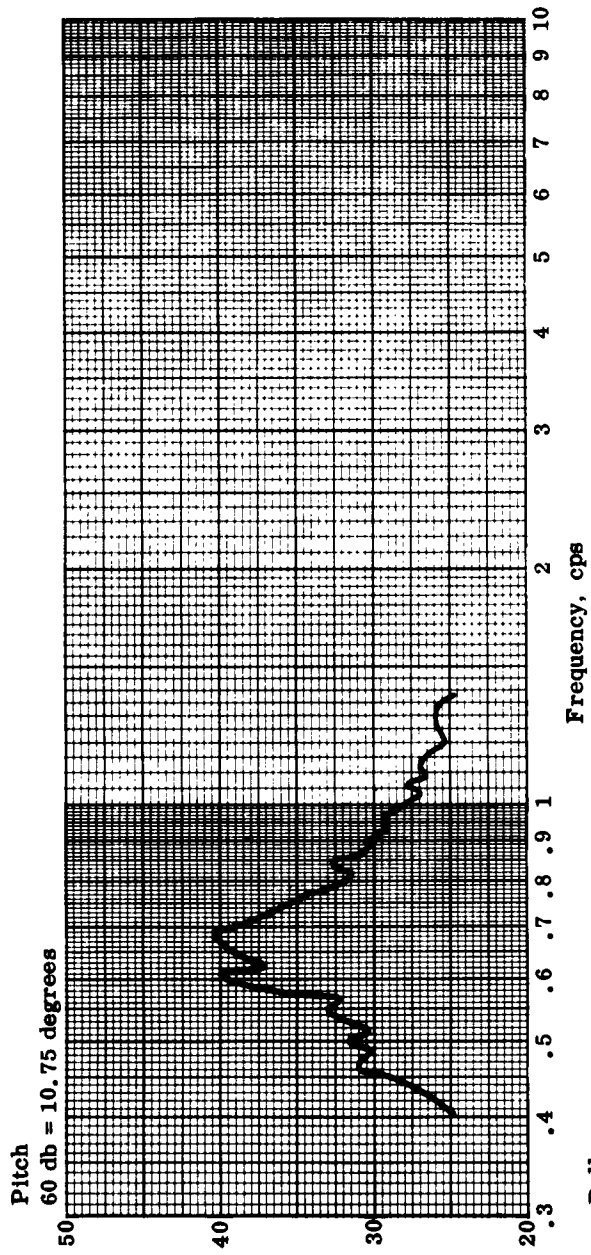
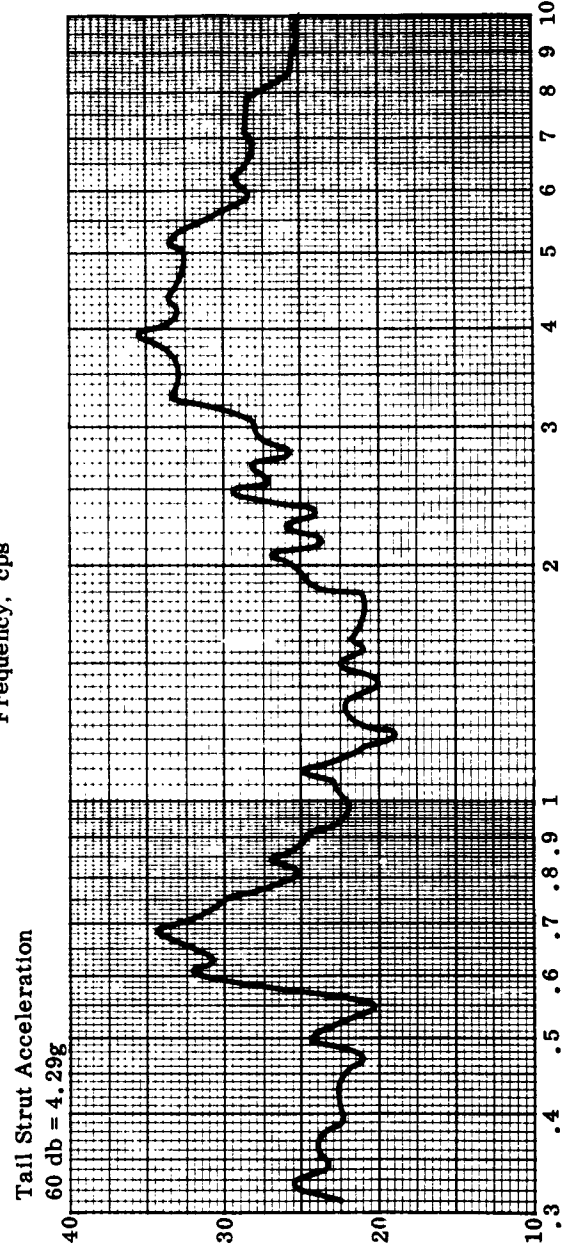
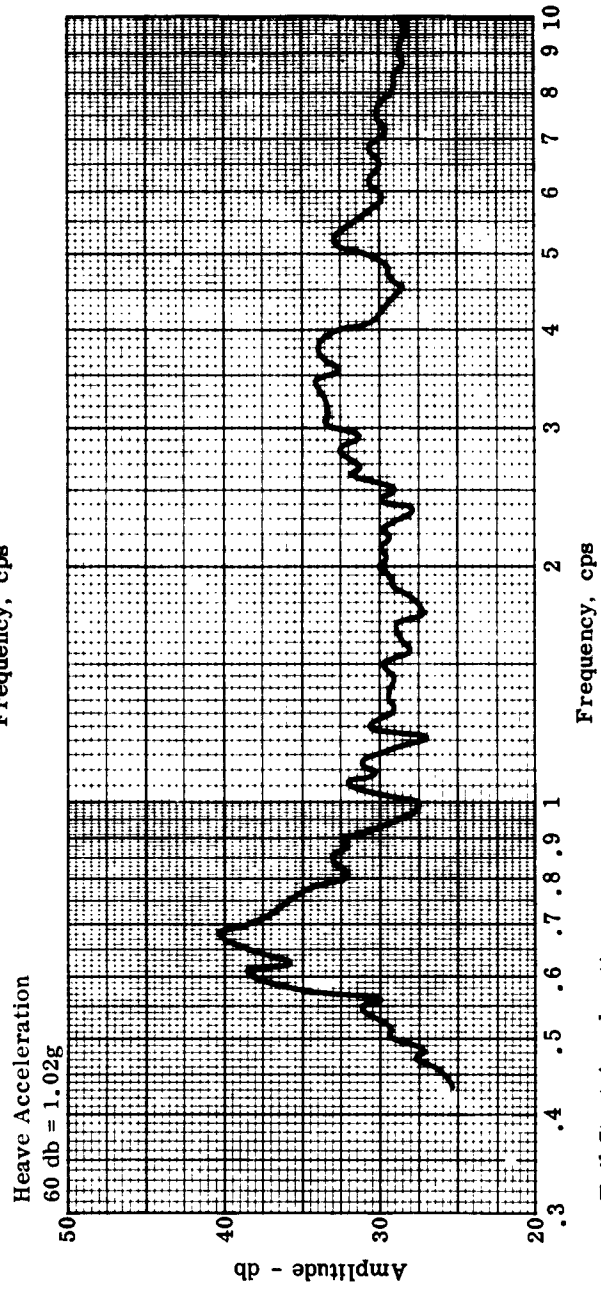
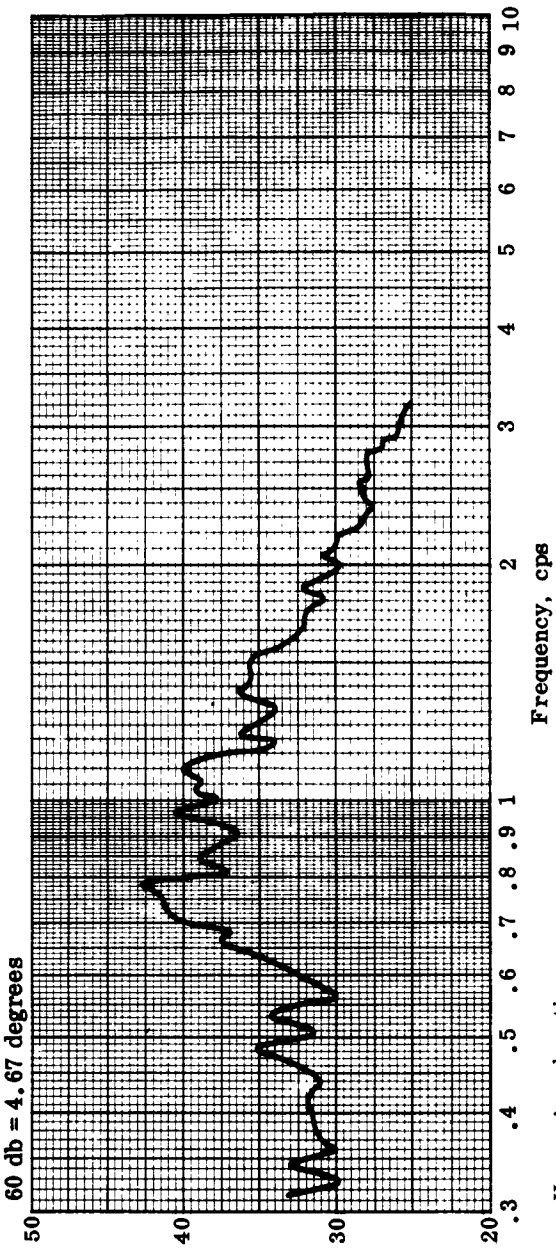

Figure 13  
FREQUENCY-AMPLITUDE SPECTRA  
Test No. 3

Speed: 40 mph  
Direction: Head Sea  
Sea Height: 6 - 8 inches

3





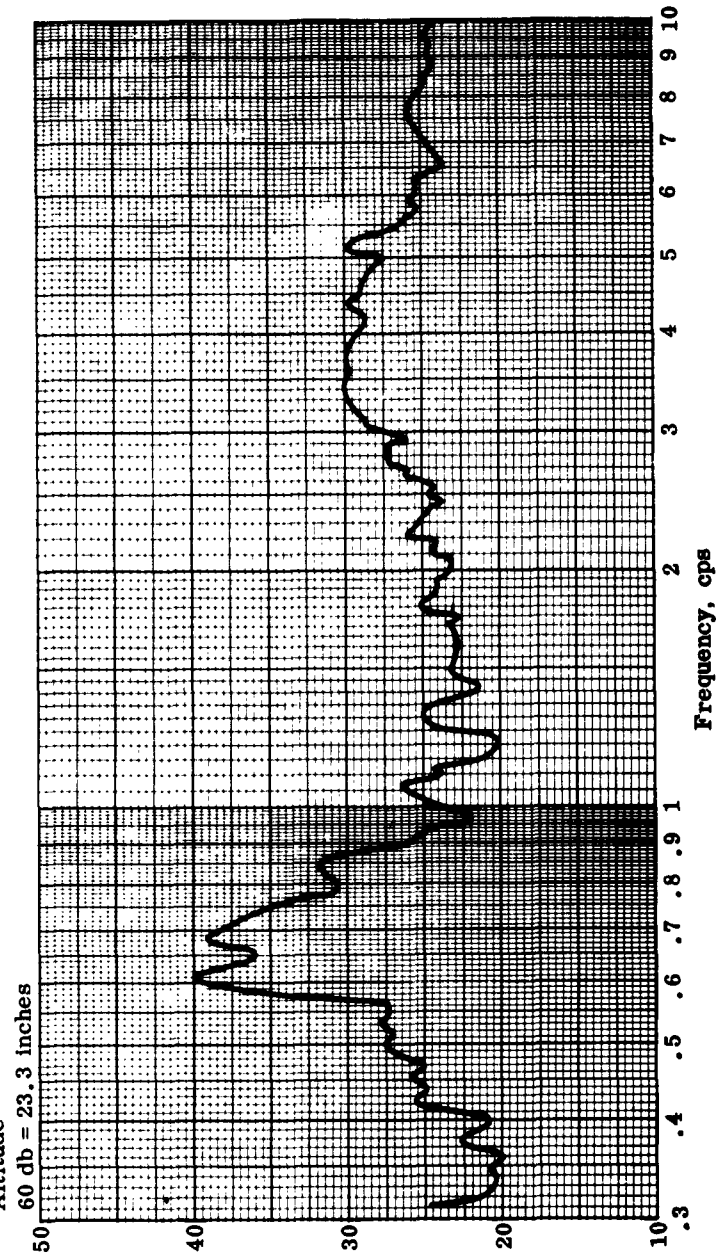
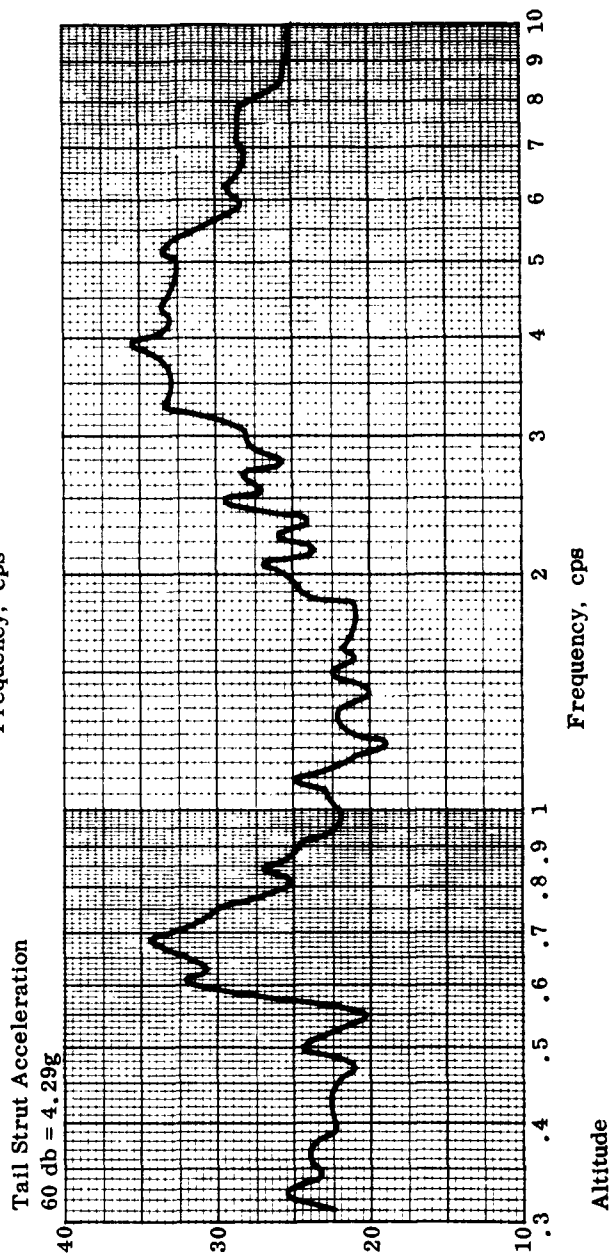
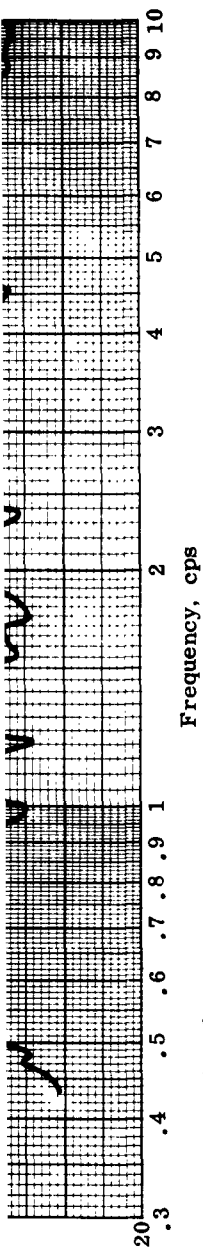

3

Figure 14  
 FREQUENCY-AMPLITUDE SPECTRA  
 Test No. 5  
 Speed: 50 mph  
 Direction: Head Seas  
 Sea Height: 12 - 15 inches

Note: The Sea State Spectra for this run appear in Figures 16 and 17

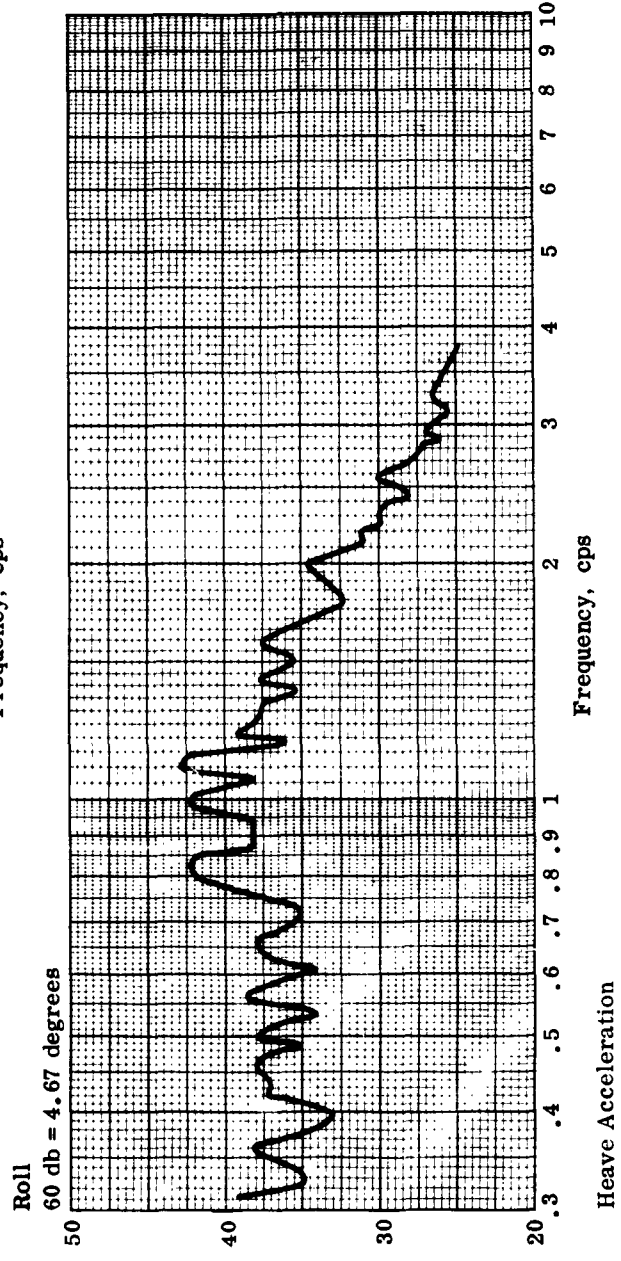
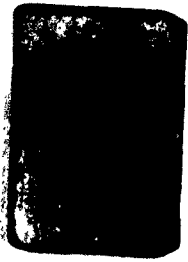
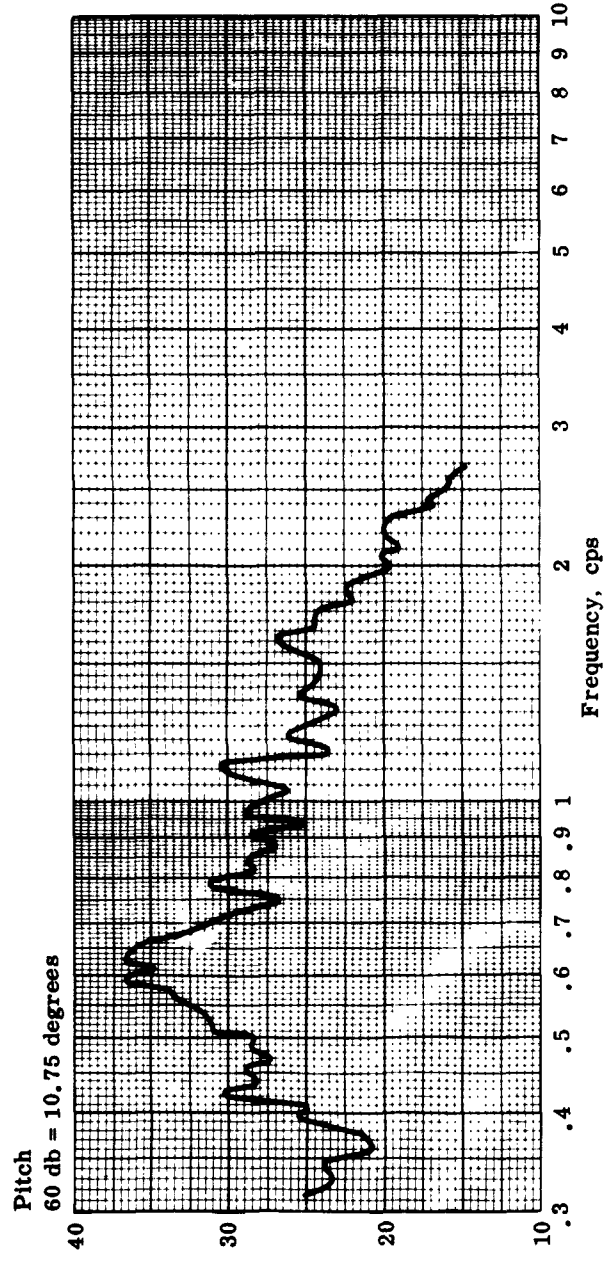

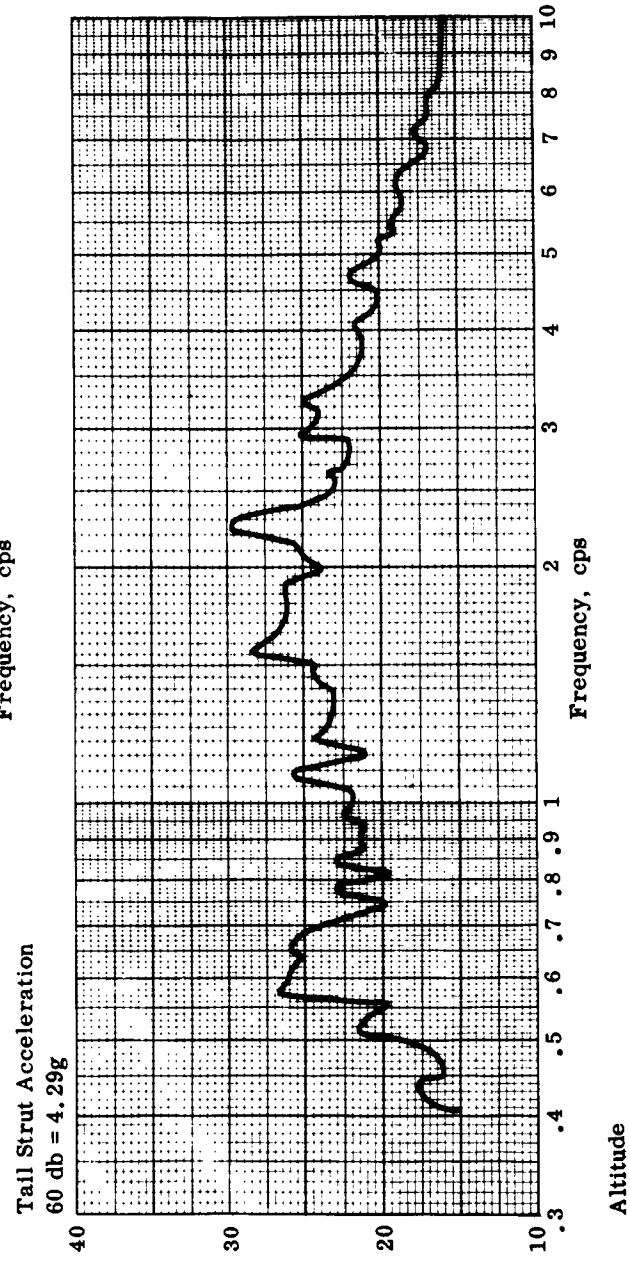
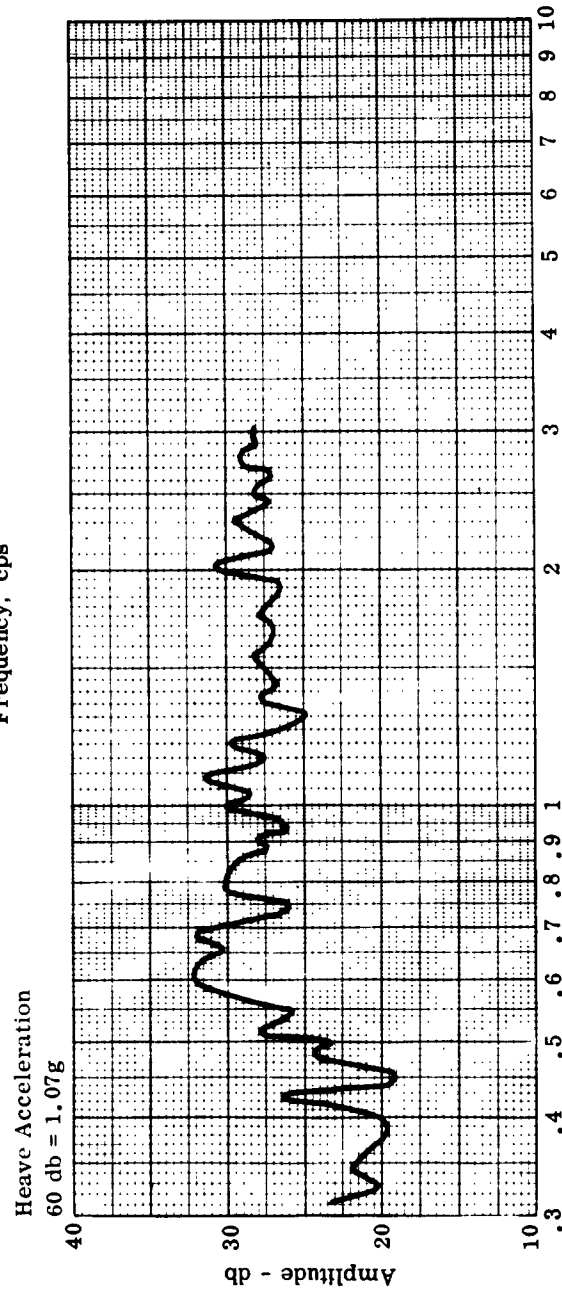
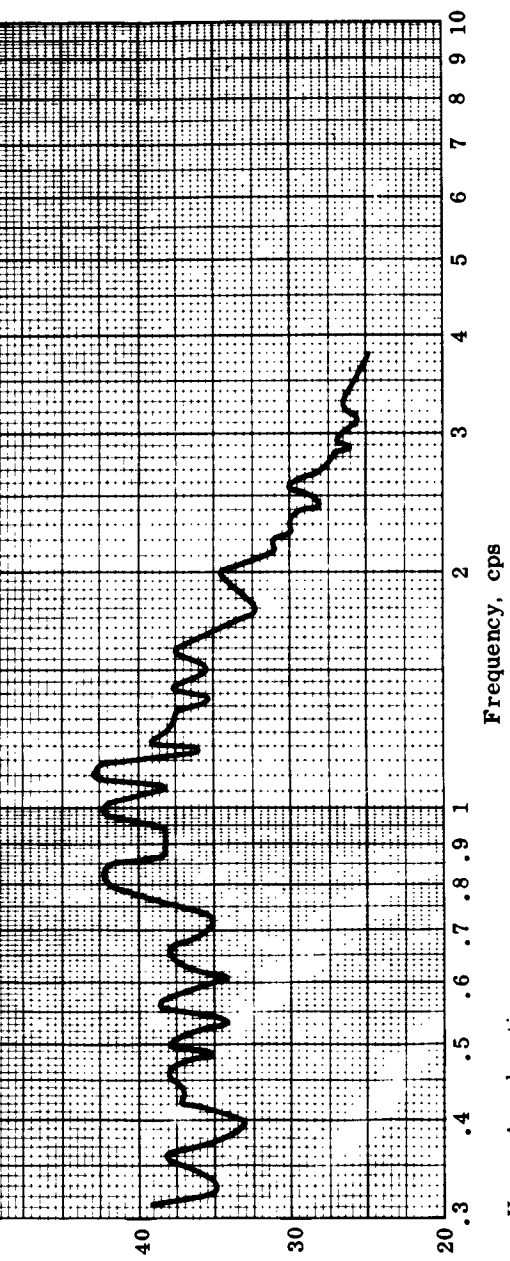

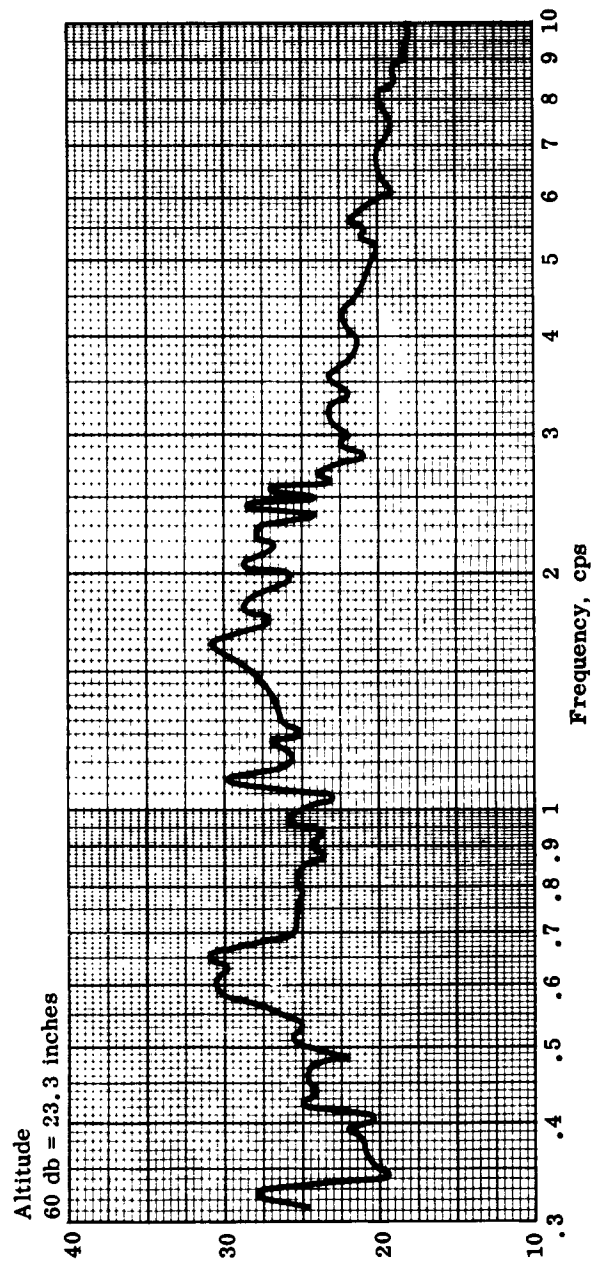
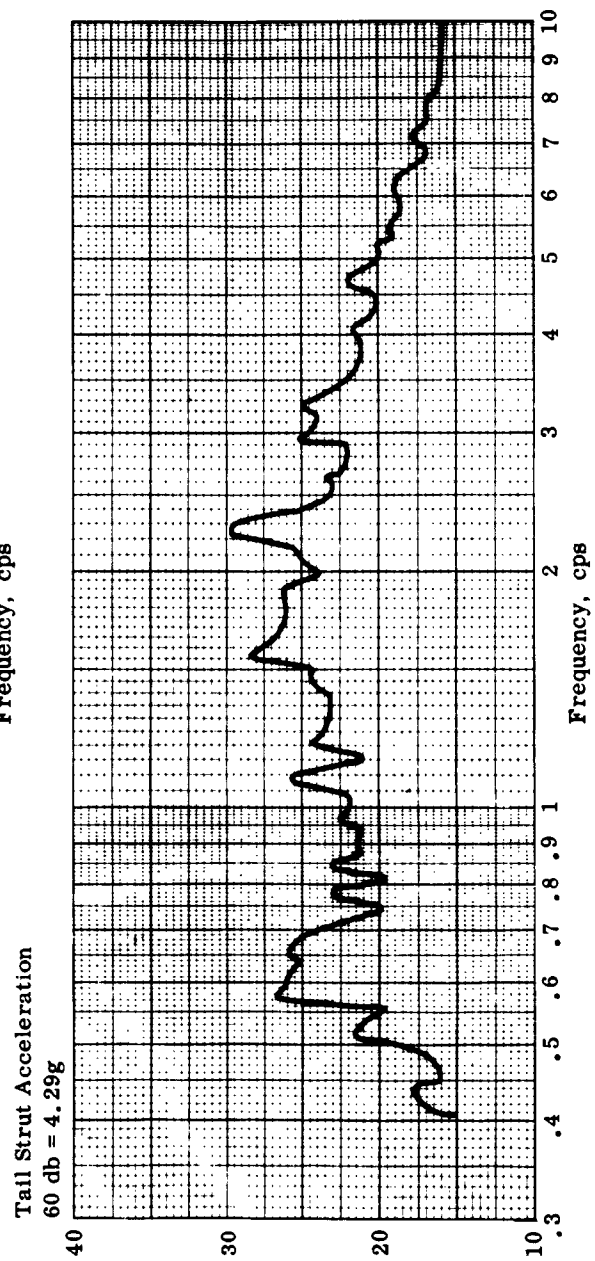
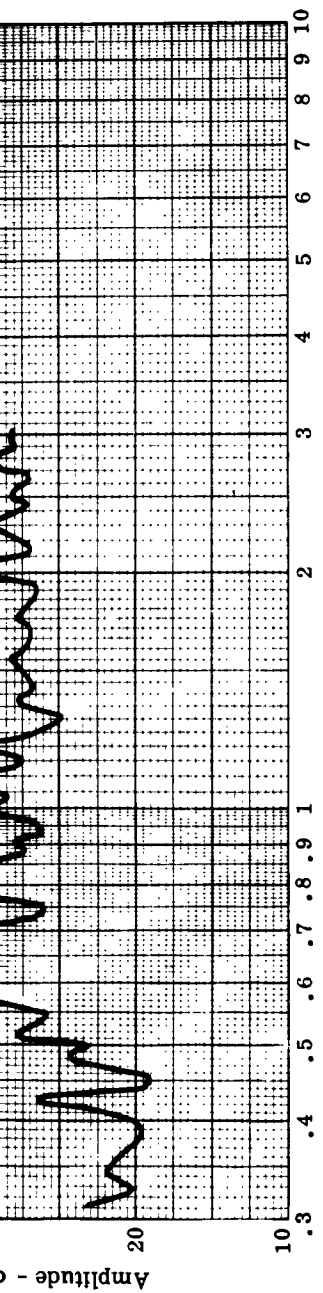

Figure 15  
FREQUENCY-AMPLITUDE SPECTRA

Test No. 5

Speed: 40 mph  
Direction: Following Seas  
Sea Height: 12 - 15 inches



Note: The Sea State Spectra for this run appear in Figures 16 and 17

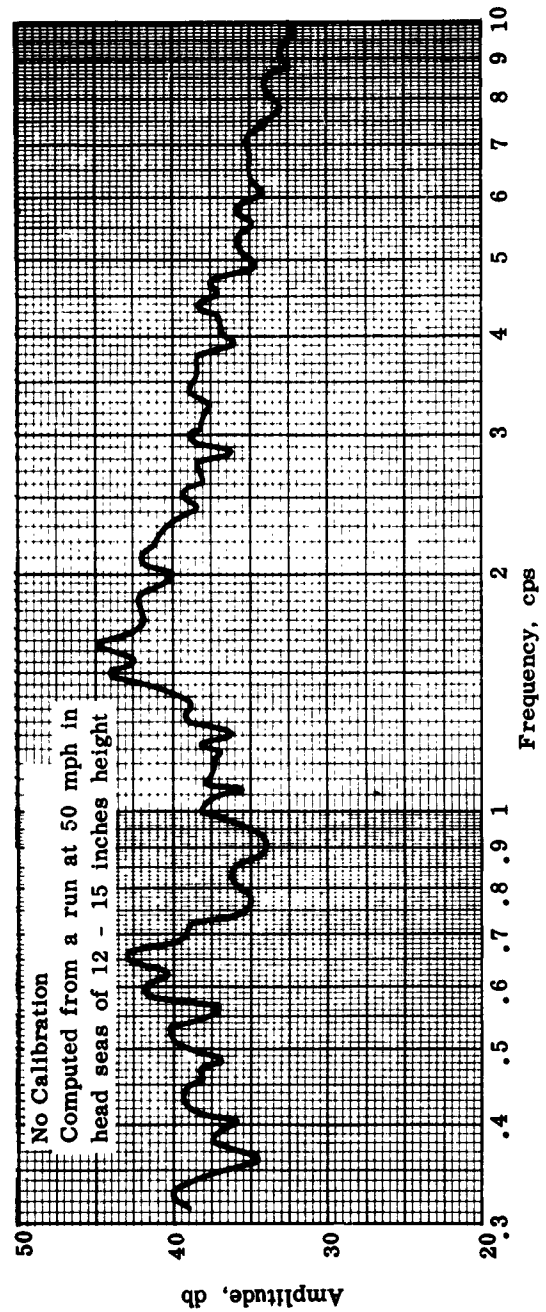
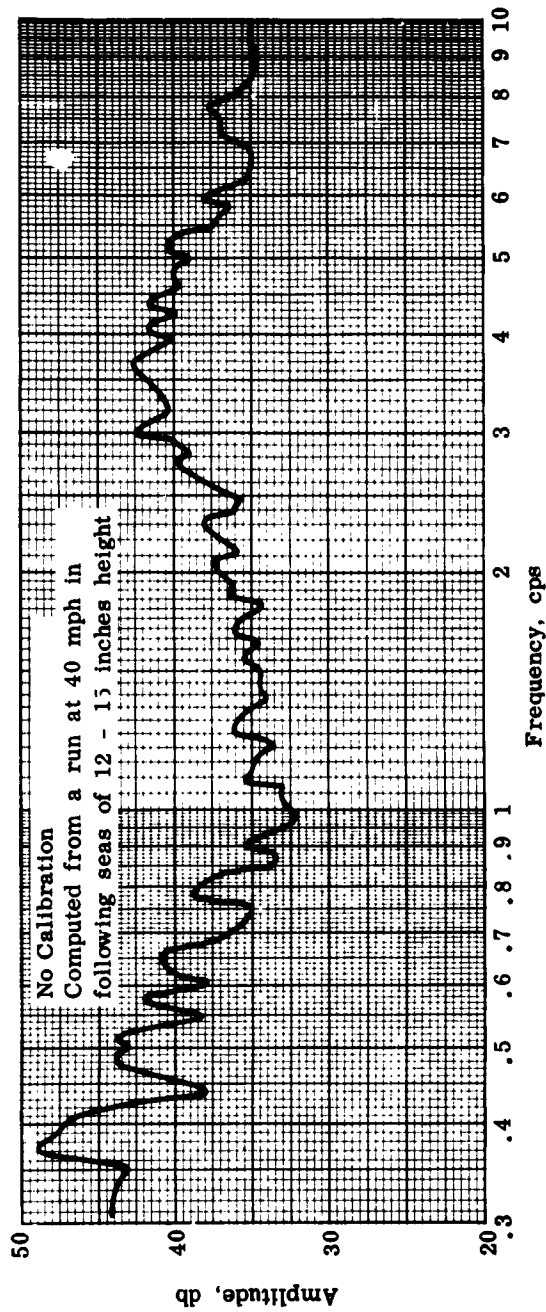
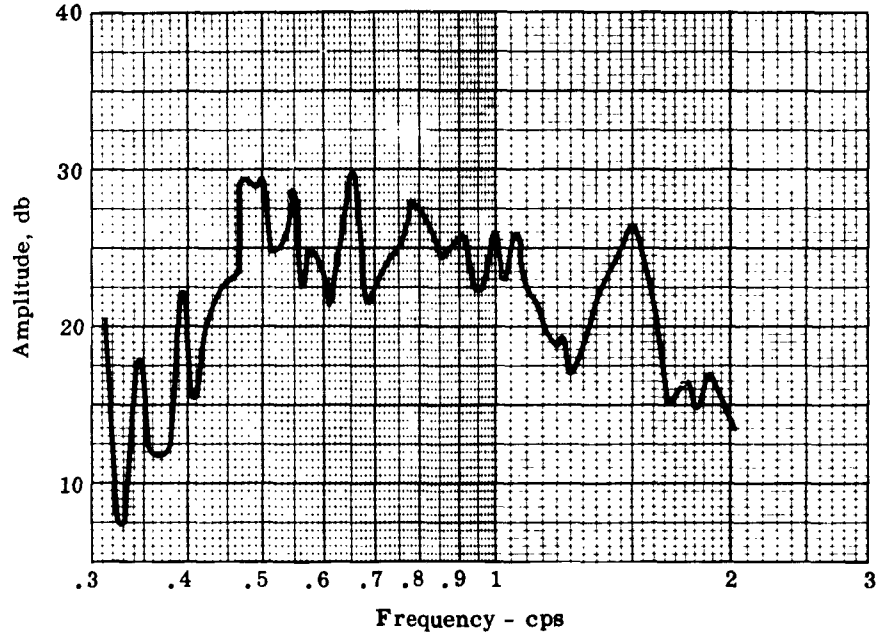
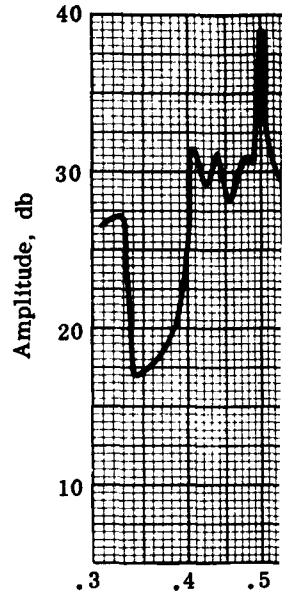

Figure 16  
 COMPUTED SEA STATE SPECTRA  
 Test No. 5

Acceleration  
50 db = .464g



Acceleration  
60 db = .464g



Displacement  
No Calibration

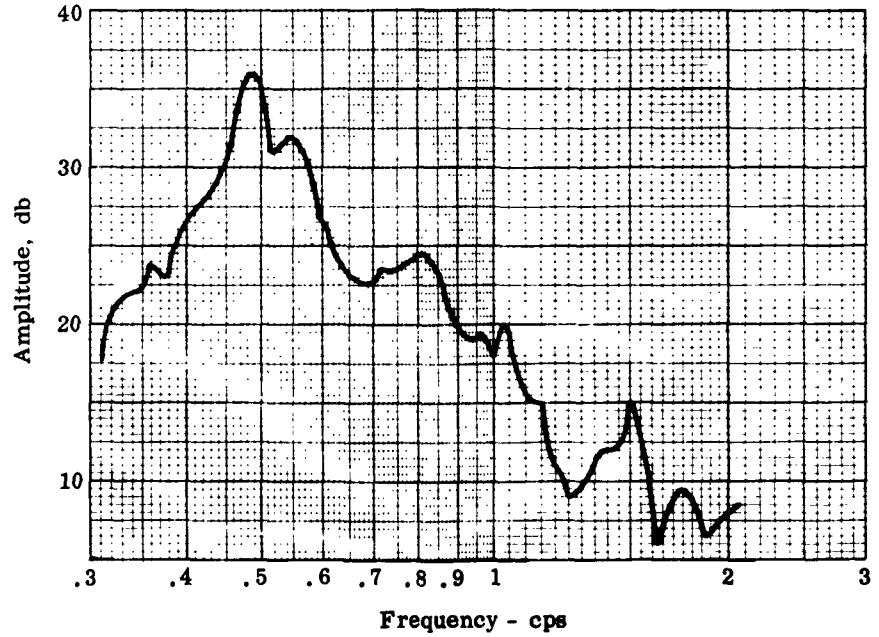

Displacement  
No Calibration

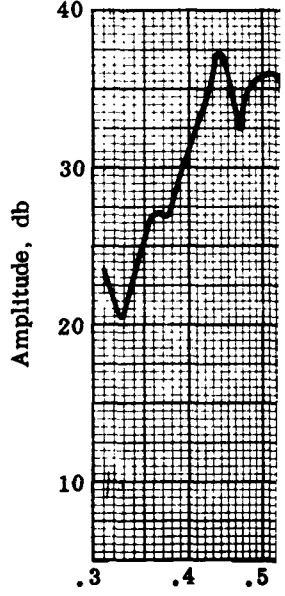

Acceleration  
60 db = .464g

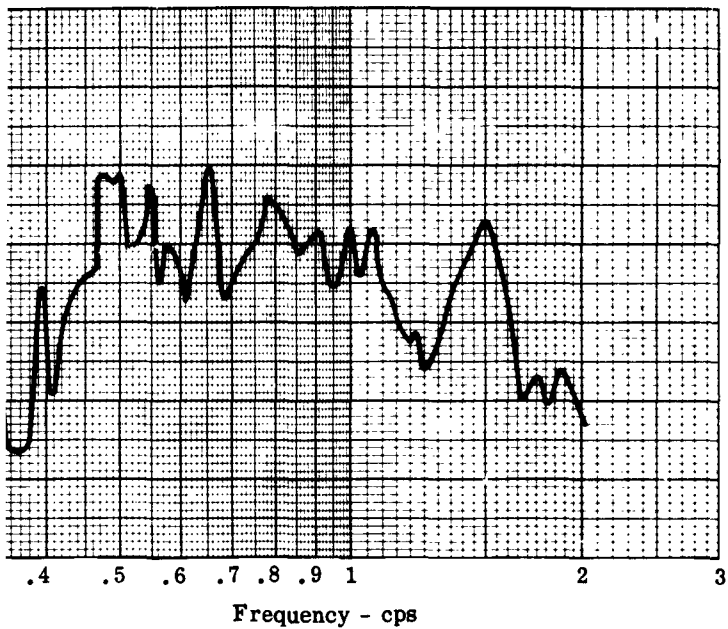

Acceleration  
60 db = .464g

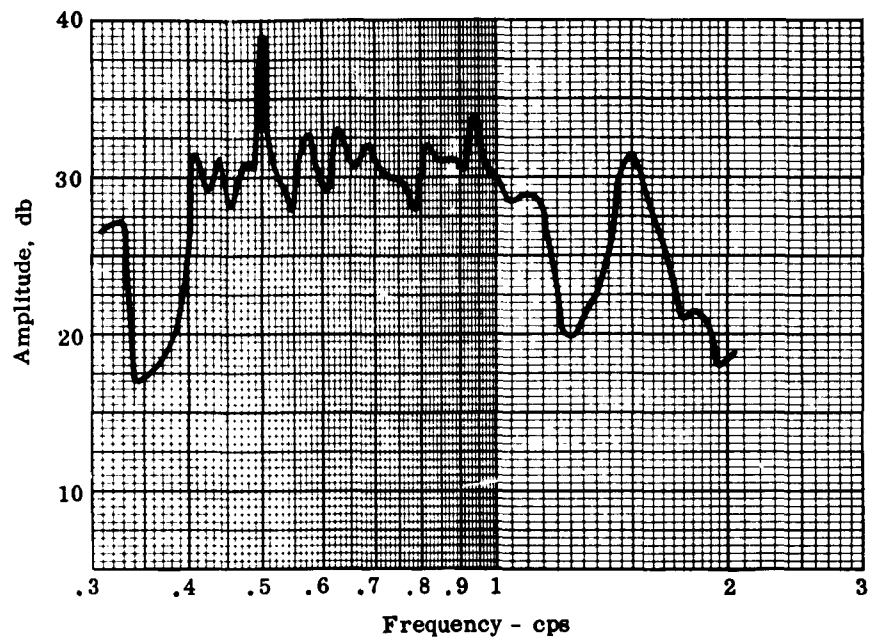

Displacement  
No Calibration

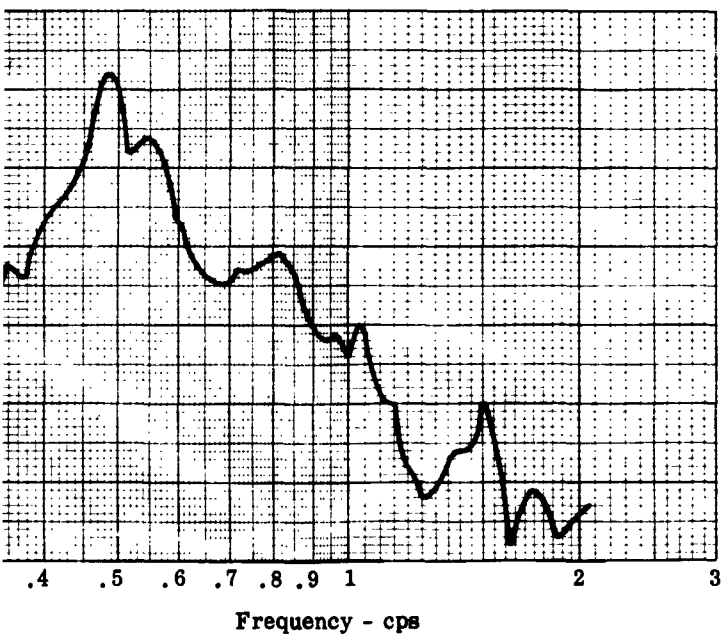

Displacement  
No Calibration

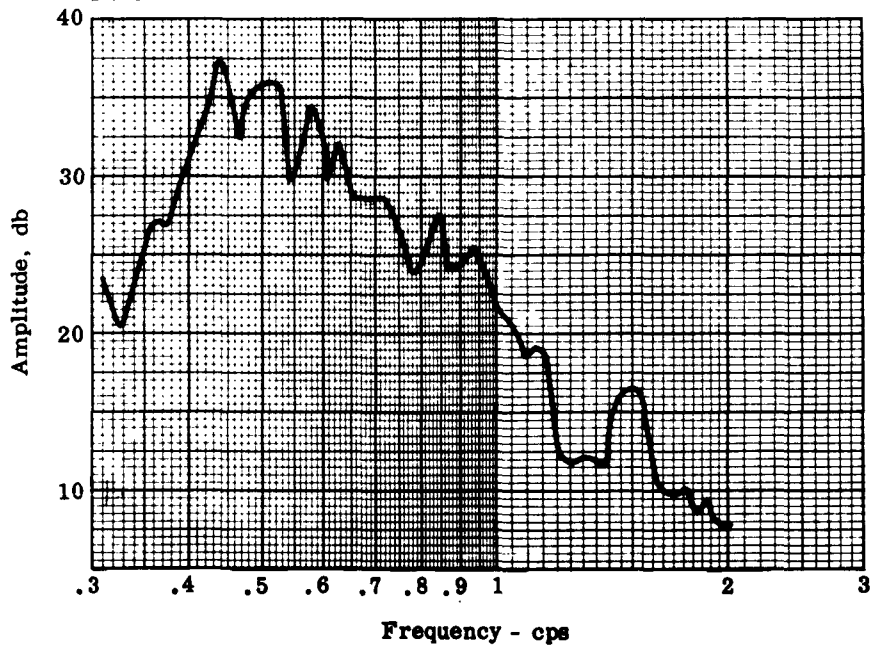

Figure 17  
SPLASHNIK SEA STATE SPECTRA  
Test No. 5  
Sea Height: 12 - 15 inches

APPENDIX A

REFERENCES

1. Grumman Report No. 133, Design Development and Initial Testing of ONR Supercavitating Hydrofoil Boat XCH-6, February 1962.
2. Grumman Report No. M.P.D. 47.134, Performance of Supercavitating Propeller on ONR Hydrofoil Boat XCH-6, March 1962
3. Grumman Report - Altimeter Operating and Trouble Shooting Manual H.S. Denison MA-2133, XCH-6 Supplement
4. DTMB Report No. 1423 Splashnik - DTMB Disposable Wave Buoy, W. Marks and R. C. Tuckerman, December 1960

APPENDIX B

DETAILED TEST PROCEDURE

Before launching the boat, the instrumentation is calibrated and the calibration recorded on tape in the receiving station.

After launching, the boat is towed to the test area by the Grumman chase boat. Radio communications are maintained between the chase boat and the receiving station.

On reaching the test site, the procedure is as follows:

1. Start engine
2. Turn on craft instrumentation
3. Receiving station tune in telemetry frequency and monitor
4. Cage gyro, allow run-up time
5. Uncage gyro, allow for erection time
6. Receiving station commence recording
7. Calibrate instrumentation
8. XCH-6 take-off
9. Calibrate prior to first data run
10. Data run; 200 seconds long if possible
11. Calibrate after data run complete

Steps 9, 10, and 11 are repeated for each data run.

A Splashnik recording is made approximately half way through the test. Both the Splashnik and the instrumentation package are calibrated after returning to the dock.