

CATALOGED BY ASTIA
AS AD NO. 401308

401 308

FINAL REPORT

CONTRACT OCD-OS-62-238

Issued by 3M Company

This report has been reviewed by the
Office of Civil Defense and is approved
for publication.

STIA
APR 17 1968
NSA A

March 15, 1963

Final Report

PROTOTYPE TESTING OF PROPOSED
RADIATION SOURCE FOR OCD DEMONSTRATION
KIT CDV-457

SUMMARY

The purpose of the program covered in Contract OCD-OS-62-238 was to design and test a beta-gamma source for use in the CDV-457 training kit. The design proposed is shown in 3M Company print #A-1921-17, attached. Ten sources were prepared according to this design, six of which were subjected to one or more of the destructive tests outlined below. The other four were submitted to the OCD for their inspection and evaluation.

The source integrity is such that, even when the sources were subjected to the very rigorous destructive tests, none of them released as much as 0.005 microcuries of radioactivity to the environment.

The data obtained from the prototype tests should be very instrumental in obtaining favorable action from the AEC on wipe relief.

INTRODUCTION

Early in 1962, the OCD decided to develop a replacement for the radium check source in the CDV-457 training kit. The source desired was to have exceptionally high structural integrity so that it could be safely distributed in the training kit and used by relatively unskilled personnel. The source was to emit beta and gamma radiation using a mixture of Strontium-90 and Cesium-137. Another objective was to demonstrate, by means of vigorous destructive tests, the integrity of the encapsulation techniques so that it might be possible to get relief from the Atomic Energy Commissions' six months wipe test requirements.

Purchase Order OCD-OS-62-238 was issued on June 22, 1962, to cover the cost of prototype source fabrication and testing. After consultation with OCD personnel, 3M Company proposed the source design shown on print #A-1921-17, attached.

These tests have now been successfully completed. The purpose of this report is to describe these tests and the results obtained.

TEST PROGRAM AND RESULTS

A total of eleven sources were prepared in this program, ten as shown on 3M drawing #A-1921-17 and one special source, as described later.

The ten sources were prepared by dispensing the proper amount of 3M Brand Radiating Microspheres into the central depression on the stainless steel source face. To obtain the desired radiation output level, the six test sources were loaded with 5 μ c of Strontium-90 and 100 μ c of Cesium-137. This was accomplished by using 5 mg of 1 mc Strontium-90 per gram microspheres and 10 mg of 10 mc Cesium-137 per gram microspheres. The microspheres were secured in the depression with 1/8 of a gram of Sauereisen (see appendix A) binder. The amount of binder used was regulated so that it was always below the lip of the depression. After the Sauereisen was cured, a 0.002 inch thick stainless steel window was silver brazed (Easy Flo #45, m.p. 1145 F) in place. Excess flux and silver braze were removed by sandblasting. The sources were wipe tested (see appendix B) with a moistened one-half inch cube of cellulose sponge. All wipe tests showed less than 0.005 microcuries of removable activity. The sources were then subjected to the tests according to the schedule in Table I.

TABLE I

<u>Source #</u>	<u>Test Description</u>
1	Heat to 1000°C, hold for 30 minutes, remove from furnace.
2	Heat to 800°C, quench in flowing water at 10°C.
3	Immerse in molten Aluminum at 700°C for 30 minutes.
4	Ten 2 foot-pound impacts on active face with a hemispherical impact hammer of $\frac{1}{8}$ inch diameter.

- 5 Loose mounted vibration, 4 hours, $1\frac{1}{2}$ inch amplitude, 280 cycles per minute. Rigid mounted vibration, 1 $\frac{1}{4}$ hours, $1\frac{1}{2}$ inch amplitude, 280 cycles per minute. Abrasion, 100 2 inch strokes in 1 minute under 10 lbs. pressure with 120 grade aluminum oxide abrasive paper on active face.
- 6 Successive Soak Tests. 20 hours in 50 ml each of 0.01N HCl, 1% Versene, 0.01N NaCl. Temperature 50°C.

As soon as possible, after the completion of the test, the source was wipe tested again. In all cases, these wipes showed less than 0.005 microcuries of activity. The actual values of the wipe tests are given in appendix C. The equipment used for the tests and the surrounding area were all monitored and no significant radioactivity was found.

As further proof that no activity was released to the environment by the sources as a result of these tests, the radiation output, as measured by the CDV-457 geiger counter, was the same after the tests as it was before. These results are summarized in Table II.

TABLE II

Radiation Output
Average Counts Per Min. at 12"

<u>Source #</u>	<u>Before</u>		<u>After</u>	
	<u>Beta</u>	<u>Gamma</u>	<u>Beta</u>	<u>Gamma</u>
1	2500	225	2500	240
2	2500	225	2500	160
3	2300	190	2500	180
4	2500	225	2500	210
5	2600	150	2600	150
6	2600	150	2600	180

LOADING: 5 uc Strontium-90, 100 uc Cesium-137

A preliminary visit to the AEC to discuss the possibility of relief from the wipe test requirements for this source, brought out the point that a very pertinent piece of information would be the ability of the source to retain the radioactivity during a fire if the 0.002 inch stainless steel window were not intact. Therefore, an eleventh source was prepared using the same technique previously described, except that the window was left off. This source was heated to 1000°C for 30 minutes. After cooling, a wipe test of the source surface showed only 0.001 microcuries of removable activity. Radiation output readings before and after the test confirmed that there was no significant loss of activity. Another pertinent result of this test is the fact that the Sauereisen-microsphere plug remained firmly attached to the surface of the depression. It showed no tendency to come loose, even at the extreme temperatures used.

TECHNICAL SPECIFICATIONS

The sources used in this program can be defined by referring to 3M Company drawing #A-1921-17, attached, and to the following Technical Specifications.

- 1) Each source was loaded with 5 μc Strontium-90 and 100 μc of Cesium-137 in the form of 3M Brand Radiating Microspheres.
- 2) The ceramic matrix called 3M Brand Radiating Microspheres has the following properties:
 - a) Color - milky white.
 - b) Density - Absolute 3 grams per cc.
Bulk 2 grams per cc.
 - c) Softening point - About 1500°C.
 - d) Solubility - Insoluble in all common reagents except 57% Hydroflouric acid.
 - e) Radiation Stability - greater than 10^9 rads.
- 3) The binder used to fix the radioisotope carrier into the central depression must not react chemically with the carrier to release any radioactivity and must be capable of withstanding the radiation from the source material and 1000°C.
- 4) The silver braze used to attach the 0.002 inch window to the face of the source should be Easy Flo #45 or equivalent, with a melting point greater than 1100°F.

- 5) The completed source must be able to undergo any one of the following tests without releasing more than 0.005 microcuries of radioactivity to the environment.
- a) Being heated to 1000°C for 30 minutes.
 - b) Being heated to 800°C for 30 minutes and then immediately immersed in flowing water at 10°C.
 - c) Being immersed in molten Aluminum at 700°C for 30 minutes.
 - d) Being subjected to 10 impacts of 2 foot-pounds each from a $\frac{1}{2}$ inch diameter steel hammer hitting the active surface of the source.
 - e) Being placed loose in a rigid aluminum box which is $\frac{1}{2}$ inch larger in all inside dimension than the source and which is caused to vibrate with $1\frac{1}{2}$ inch amplitude at 280 cycles per minute for 4 hours.
 - f) Being rigidly mounted and subjected to $1\frac{1}{2}$ inch amplitude vibrations at 280 cycles per minute for 144 hours.
 - g) Being given 100 2 inch strokes in 1 minute under 10 lbs. pressure on 120 grade aluminum oxide abrasive (3M'ite Wet-or-Dry sandpaper or equivalent).
 - h) Being successively soak-tested in 0.01N HCl, 1% Versene and 0.01N NaCl at 50°C for 20 hours.

APPENDIX A

The binder used was Sauereisen Insa-Lute Adhesive Cement No. 1 Paste. This material is made by Sauereisen Cements Company, Pittsburg 15, Pennsylvania. The recommended cure is 24 hours at 150°F or higher.

APPENDIX B

Wipe Test Procedure

Use one-half inch cube of cellulose sponge. Moisten one face of the sponge with 8-10 drops of water. Vigorously wipe the active face of the source at least three times with the moistened side of the sponge. Count the sponge for radioactivity with the moistened side of the sponge closest to the counter. The counting system must be capable of detecting at least 0.0005 microcuries of radioactivity.

APPENDIX C

<u>Test</u>	<u>Wipe Test Results, microcuries</u>	
	<u>First</u>	<u>Second</u>
1000°C exposure	0.004	<0.0001
800°C Thermal Shock	0.002	<0.0001
700°C Molten Aluminum	<0.0001	----
Impact Test	0.004	<0.0001
Vibration (after each part)	<0.0001	
Abrasion Test	<0.0001	
Soak Test (2)		
50 cc 1% Versene	20 hours at 50°C	No detectable activity (1)
50 cc 0.01N NaCl	20 hours at 50°C	No detectable activity (1)
50 cc 0.01N HCl	20 hours at 50°C	No detectable activity (1)

(1) The solutions used were counted for radioactivity. Two 1 ml portions were evaporated on counting pans and then counted. Under these conditions, the minimum detectable activity is 0.005 microcuries.

(2) After each soak test the source was dried and wipe tested. In each case, the wipe removed <0.0001 microcuries of activity.

APPENDIX D

Average Gamma Dose Rates
Around Prototype Source

Front (1)

60 mr per hour

Back (1)

9 mr per hour

Sides (1)

12 mr per hour

- (1) Readings taken with Nuclear Chicago Model 2586 Air Ionization Chamber. Sources were placed in contact with side of the chamber. The center of the active volume is 1-3/4 inches from the side.
- (2) With the source $\frac{1}{4}$ inch away and facing the end window of the ionization chamber, the beta reading averaged 260 mr per hour and the gamma reading averaged 12 mr per hour. The center of the active volume is 2 inches from the end window of the chamber.

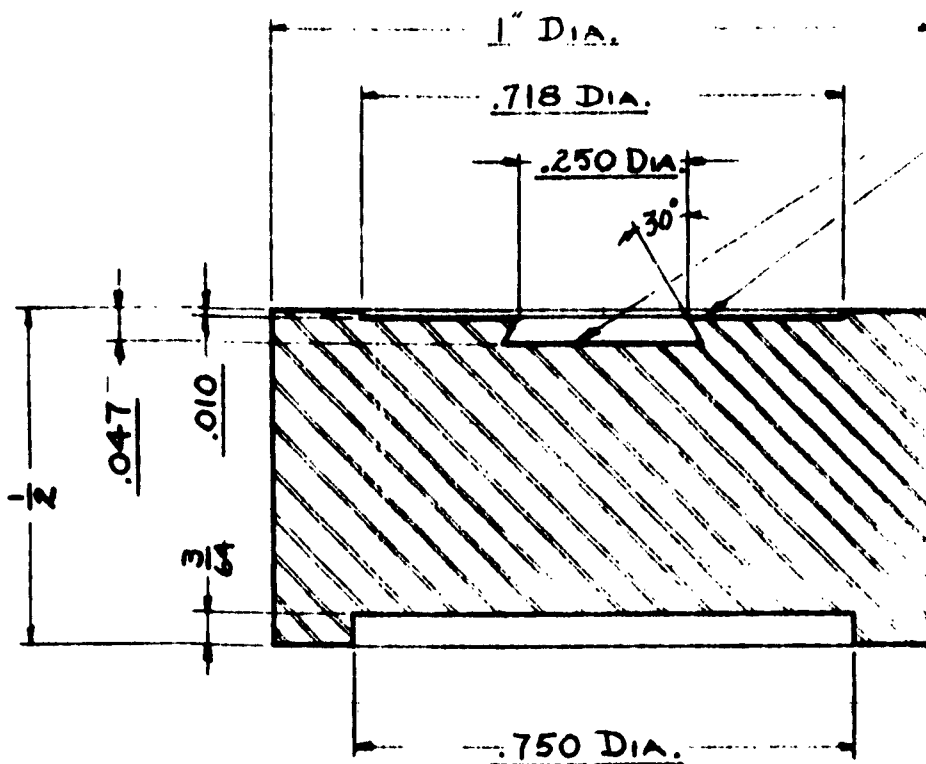

3 M BRAND RADIATING MICROSPERES
FIXED IN POSITION WITH
INORGANIC BINDER

△ .002" THICK S.S.-300 SERIES-DISC
SILVER BRAZE IN PLACE

MAT'L.: STAINLESS STEEL - 300 SERIES △

USED ON		31	2	MARCH 21, 1963	JDS
EXCEPT AS NOTED. FINISH		32	1	△ ADD 300 SERIES △ CHANGED FROM .003 THK. OCT. 29, 1962	
EXCEPT AS NOTED. TOLERANCES FRAC. DIM. ± 1/64 WELD-CSTS DIM. ± - DEC. DIM. ± .005 ANGULAR DIM. ± 2°		DR. H. LANDEEN	DIVISION STAFF LAB. Eng. PROJ		
CH.		APP.	TITLE		
MINNESOTA MINING & MANUFACTURING CO. ST. PAUL, MINNESOTA		A	OCD SR - Cs CHECK SOURCE		
			1921	17	

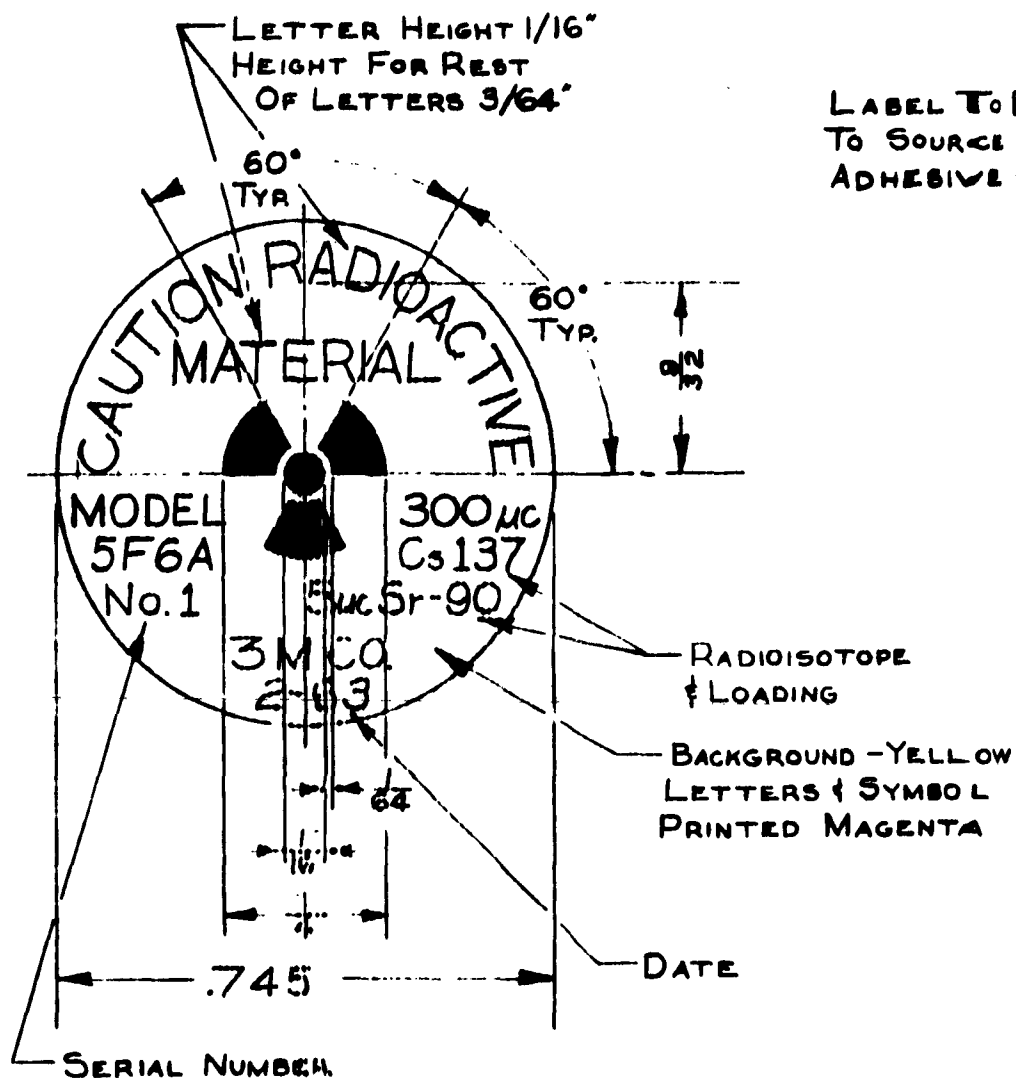

LABEL TO BE ATTACHED
TO SOURCE WITH ECB47
ADHESIVE OR EQUAL

MAT'L.
.030 THICK ALUMINUM
OR BRASS

USER ON		31	1 MARCH 20, 1963		
EXCEPT AS NOTED. FINISH		ISSUE		ISSUE DATE AND CHANGE RECORD	
EXCEPT AS NOTED. TOLERANCES		DIVISION STAFF LAB ENG R. PROJ.			
FRAC. DIM. $\pm 1/64$		TITLE			
DEC. DIM. $\pm .005$		LABEL -			
DR. J.D. SWENSON		CHECK SOURCE			
SCALE 4" = 1"					
CH.					
MINNESOTA MINING & MANUFACTURING CO. ST. PAUL, MINNESOTA		A		1921 39	