

TM(L)-832/000/01

SCHOPS/Switch Control

Interface Document

1 March 1963

APR 18 1963
TISIA

401 451

TECHNICAL MEMORANDUM

(TM Series)

ASTIA AVAILABILITY NOTICE

Qualified requesters may obtain
copies of this report from ASTIA.

This document was produced by SDC in performance of contract AF 19(628)-1648, Space
Systems Division Program, for Space Systems Division, AFSC.

SCHOPS/Switch Control
Interface Document

By

M. A. Franks

1 March 1963

Approved

R. A. Totschek

SYSTEM

DEVELOPMENT

CORPORATION

2500 COLORADO AVE.

SANTA MONICA

CALIFORNIA

The views, conclusions or recommendations expressed in this document do not necessarily reflect the official views or policies of agencies of the United States Government.

Permission to quote from this document or to reproduce it, wholly or in part, should be obtained in advance from the System Development Corporation.

Although this document contains no classified information it has not been cleared for open publication by the Department of Defense. Open publication, wholly or in part, is prohibited without the prior approval of the System Development Corporation.



1 SUBSYSTEM DESCRIPTION

1. 1. General

This document supersedes the SCHOPS/Switch Control Interface Document, TM(L)-832/000/00, dated 15 November 1962. Part of the information for updating is derived from SCHOPS/Switch Control Interface meetings held on 4 January 1963 and 14 February 1963. Other information is from the document Milestone 4 for Control 160A Computer at STA (LMSC-656952), dated 15 January 1963, by E. M. Malone, E. Peabody, and E. D. Rodrigues.

SDC is responsible for designing the SCHOPS portion of the interface; LMSC is responsible for designing the switch control, including the design of the switching hardware and the CDC 160A Switch Control program.

SCHOPS is a scheduling program designed and written for the CDC 1604, which allocates the use of specified pieces of equipment or equipment complexes at the Satellite Test Annex (STA) and remote tracking stations for specific tasks on a temporal basis. In performing this function, SCHOPS assists the System Controller (SC) in the resolution of conflicts in demands for specific equipment and provides other necessary information for implementing the control of this equipment.

A primary product of SCHOPS, then, is a schedule of resource allocations for a prescribed scheduling period. The LMSC developed Switch Control program, in turn, effects the actual switching of communication lines between the automatic data handling equipment, displays, and control equipment at the STA.

1.2 SCHOPS Side of Interface

SCHOPS produces a table of resolved rise and set times and vehicle-station identifiers. It also maintains a set of equipment status tables, generates tables for scheduling 1604 flight support operations, and determines the intervals during which the CDC 1604 Bird Buffer complexes communicate with tracking stations on the one hand and with 1604 complexes on the other. (Bird Buffer/Tracking Station communications include both pass-associated operations and free-time transmissions.) From these tables, SCHOPS produces an output tape which includes the necessary information to be passed on to the switch control 160A, such as the time-ordered assignments of equipment to the switch coordinates and the necessary equipment identifiers. It also produces printed schedules for use by such operations personnel as the SC, the Test Controllers, and the person responsible for operating the switches, called the Master Data Controller (MDC).

SCHOPS accepts input information, such as equipment status data, assignment data, and operational priorities, which is used to allocate vehicle-station contacts and, in turn, to determine the switch-setting information. SCHOPS also has the capability to accept updated equipment information, such as equipment assignment or configuration changes, and "Security Lockout" data.

1.3 Switch Control Side of the Interface

The Switch Control program is designed to control the switching operations necessary to connect the Bird Buffer computers to the tracking stations through the Communications Data Select and Cross Connect unit (CDSCCU) and to the 1604 computers and 166 printers through the Computer Select and Cross Connect Unit (CSCCU). To perform this function, the Switch Control program receives a switch-schedule tape generated by the SCHOPS system. This tape contains information which describes the correspondence between the physical equipment, the CDSCCU and CSCCU, and the vehicle designations. In addition, the switch-schedule tape contains information which describes the various switching operations to be performed during the SCHOPS schedule interval.

The Switch Control program monitors actions from the Master Data Control Console (MDCC) and prints the status of these actions on the MDCC associated 166 printer. The switch-control computer receives interrupts from the MDCC, when actions are taken there, so that the switch status tables can be updated. Figure 1 illustrates the configuration of the switch-control complex*. Crosspoint connections, shown as black dots, illustrate a possible equipment configuration. Bird Buffer 04, for example, is connected to a tracking station assigned to coordinate 3 on the CDSCCU side. On the CSCCU side, this bird buffer is connected to 1604-2 and to 166 printers 01 and 52. Periodically, the status of all crosspoints of the CDSCCU and CSCCU is printed on the MDCC 166 printer. Switch commands input to the 160A are referenced to a unique system time. To execute the command, the Switch Control program compares the current system time with the time associated with the command being processed. Current system time is input to the 160A control computer through the Computer Timing Buffer Equipment (CTBE).

The Switch Control program may receive additional inputs from cards which contain schedule overrides, equipment changes, equipment assignment changes, and security lockout information.

*Transition equipment, such as the 1607 tape drives (connected between the CSCCU and the 1604 computers) and the Communication Coupling Converters (connected between the Bird Buffers and the CDSCCU), is not shown in the illustration.

(2B Blank)

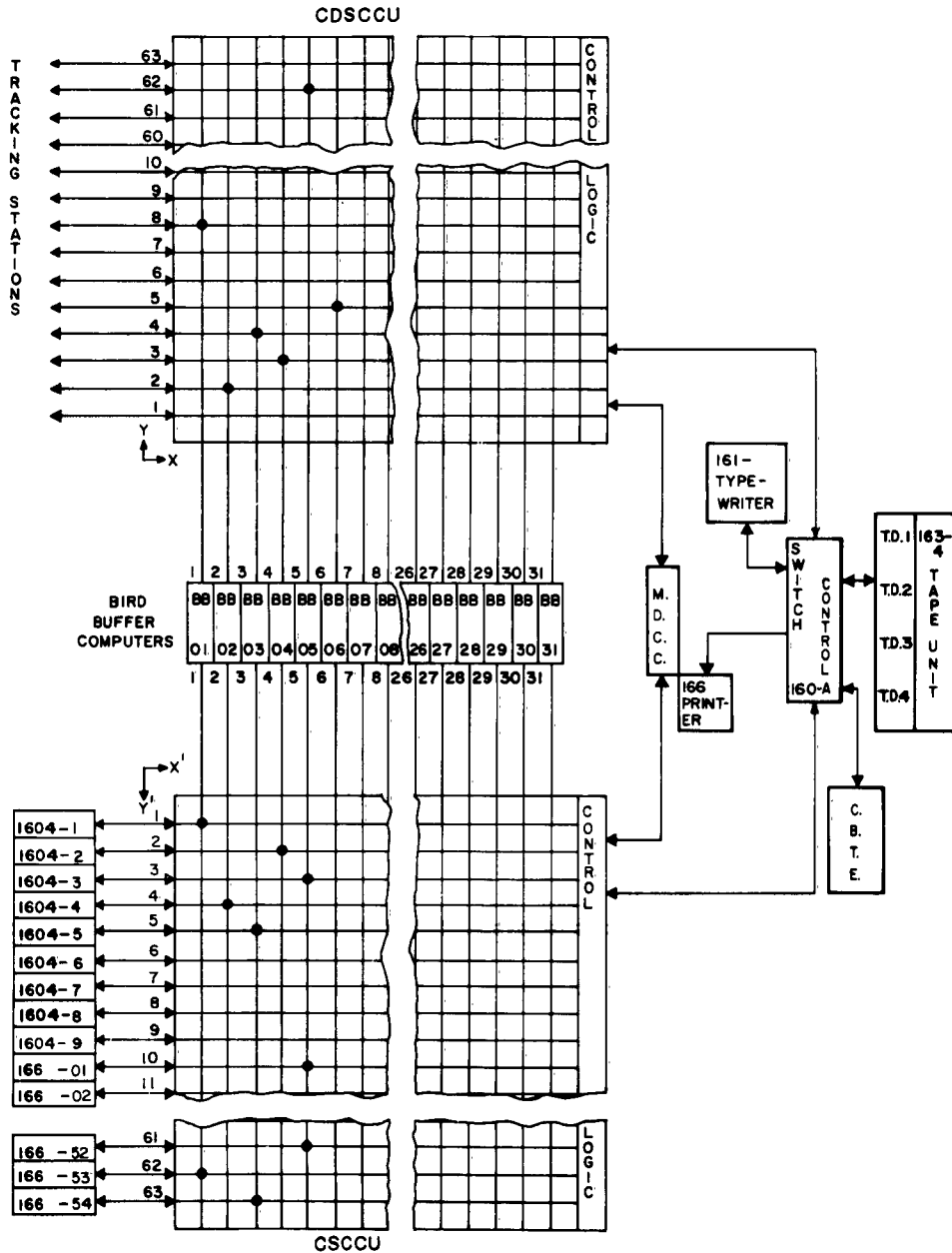

FIGURE 1: STA SWITCH CONTROL COMPLEX

FIGURE 1: STA SWITCH CONTROL COMPLEX

The Switch Control program generates a listable history tape of all switch actions performed. This tape contains the status of the crosspoints of the CDSCCU and CSCCU at the beginning of the tape and again at the end of the tape. The history tape will be processed by an off-line program other than SCHOPS.

1.4 Interface Procedure

Although it is not exhaustive, the procedure is intended to be sufficiently detailed to define the interface between the two programs.

1.5 Equipment

1.5.1 SCHOPS uses the following equipment:

- a. One CDC 1604 Computer.
- b. Two CDC 1607 Units.
- c. One Card Reader.
- d. One Card Punch.
- e. One 1612 Printer.

1.5.2 The Switch Control System uses the following equipment:

- a. One CDC 160A Computer.
- b. One CDC 163-4 Tape Unit.
- c. One 166 Printer (at the MDCC).
- d. One 161 Typewriter.
- e. One Master Data Control Console (MDCC).
- f. One Communications Data Select and Cross Connect Unit (CDSCCU).
- g. One Computer Select and Cross Connect Unit (CSCCU).
- h. One Card Reader.

1 March 1963

-4-

TM(L)-832/000/01

2 TAPE FORMATS

2.1 Switch Schedule Tape

The switch schedule tape is composed of three types of records: header records, equipment identification records, and switch records. Each record is fifty 1604 words in length. The record formats are described below. Blank words contain zeros.

1 March 1963

-5-

TM(L)-832/000/01

Type 1 Record: Header Record

Words 1, 2, 3, 4

47	all ones											0	
47	"SCHEDULE" in bcd											0	
47	36	35	30	29	24	23	day			18	17	16	0
	zeros	year	month							system time			
47	46	45	41	40	24			23	22	21	17	16	0
		day	start time of schedule period						day	stop time of schedule period			

Words 5 through 50 contain full zeros.

Type II Record: Equipment ID Record

This record type consists of two tables which establish a correspondence between the physical and functional equipment designations. The first record contains TABLEIN and the next four records contain TABLEOUT. These formats are described below. Blank words contain zeros.

TABLEIN (4 blocks) Ordered by arbitrary number.

Block I (16 words) contains Y coordinates for the data lines on the CDSCCU

word 1

47	45	44	43	42	36	35	31	30	24	23	19	18	12	11	7	6	0
100				Y coord				Y coord				Y coord				Y coord	
(binary)				Eq. 1				Eq. 2				Eq. 3				Eq. 4	

words 2-16 Same formats for equipment numbers 5-64.

Block II (8 words)

same formats, but contain X coordinates for the Bird Buffers on the CDSCCU.

Block III (8 words)

same formats, but contain X coordinates for the Bird Buffers on the CSCCU.

Block IV (16 words)

same formats as above, but contain Y coordinates for computer and display equipment on the CSCCU.

TABLEOUT (4 blocks) Ordered by coordinate.

Block I (128 words)

words 1 and 2

												11	B			0							
47											12	11	8	7	Zeros		0						
												A											
47											24	23			12	11	9	8	6	5	3	2	0
												C			E			E			E		

1 March 1963

-7-

TM(L)-832/000/01

A = six BCD characters of equipment ID on Y coordinates of the CDSCCU.
B = first two decimal digits of vehicle number in four-bit BCD.
C = last four decimal digits of vehicle number in four-bit BCD.
D = analysis (AN), presentation (PR), or zeros.
E = octal digit, arbitrary equipment number, right justified.

Block II (64 words)

same format as above, but for Bird Buffers on the X coordinates of the CDSCCU.

Block III (64 words)

same format as above, but for Bird Buffers on the X coordinates of the CSCCU.

Block IV (128 words)

same format as above, but for computer equipment on the Y coordinates of the CSCCU.

Type III Records: Switch Record

These records are fifty 1604 words in length.

all words

47	46	45	41	40	24	20	12	11	10	9	8	0
		day			system time					C/D*		
						eq. no. on X coord					eq. no. on Y coord	

The last switch action on tape is followed by full zero words for the remainder of the 50-word record. Following the last Type III record is an EOF record.

*Bit 9 = 1, connect

10 = 1, disconnect

2.2 History Tape

The history tape will be written by the 160A computer in a BCD format. There are 3 files on the tape.

2.2.1 Status File

A. Header Record

<u>1604 Word</u>	<u>Character</u>	<u>Content</u>
1	1-3	Word count
	4-8	Unique ID
2	1-8	Year-Month
3	1-8	Day-Seconds
4	1-8	Look ahead

B. Data Records

1. Equipment Assignment

<u>1604 Word</u>	<u>Character</u>	<u>Content</u>
1	1-3	Word count
	4-5	Line number
	6	blank
	7-8 }	Station, Equipment
2	1-3 }	or Bird Buffer label
	4	blank

<u>1604 Word</u>	<u>Character</u>	<u>Content</u>
3	5-8 }	Vehicle number
	1-2 }	if applicable
	3	blank
	4-6	Use tag for printer on/off for 1604, others blank
	7	blank
4	8 }	Arbitrary number
	1-2 }	
5	3-8 }	blank
		Look ahead

2. Switch Setting

<u>1604 Word</u>	<u>Character</u>	<u>Content</u>
1	1-3	Word count
	4-8 }	Veh # for printer or 1604-label
	1 }	Printer use tag
	2-4	blank
	5	Bird buffer label
	6-8 }	
	1-2 }	blank
	3	Station label
	4-8	blank
	1	Bird Buffer
	2-7	vehicle number
8	blank	
1-8	Look ahead	

3. Lockout

<u>1604 Word</u>	<u>Character</u>	<u>Content</u>
1	1-3	Word count
	4-5	Line number
	6	blank
	7-8 }	Station or
	1-3 }	Equipment label
2	4	blank
	5-7	YLO if line lockout exists, blank if not
3-14 (as needed)	8	blank
		Bird buffer - numbers of all BB whose connection to this line is under security lockout
		Look ahead
last		

2.2.2 Schedule Tape Switch Actions

A. Header Record

<u>1604 Word</u>	<u>Character</u>	<u>Content</u>
1	1-3	Word count
	4	blank
	5-8	Schedule tape
2	1-4	Time
	5-8	blank
3		Look ahead

B. Action Record

1. Switch Action

<u>1604 Word</u>	<u>Character</u>	<u>Content</u>
1	1	blank
	2-4	Word count
	5-6	blank
	7-8	** if alarm, blank if not
2	1-2	blank
	3-8 }	Time, day
3	1-2 }	and seconds
	3-4 }	blank
	5	C or D
	6-8	blank
4	1-6	Printer veh #
		or 1604 label
	7-8	Printer use tag or 1604 ON/OFF
5	1-2	blank
	3-7	Bird Buffer label
	8	blank
6	1-2	
	3-7	Station label
	8	blank
7	1-2	blank
	3-8	Bird Buffer Vehicle Number
8	1-2	blank
	3-8 }	Reason for action (MDCC, YLO, CLO,
9	1-2 }	SECURITY, etc.)
	3-8	blank
10	1-5	Previous BB connection on this line
	6-8	blank
11	1-5	Scheduled BB connection on this line
	6-8	blank
		Remarks
12		Look ahead

1 March 1963

-11-

TM(L)-832/000/01

2. Card Actions

This is an exact BCD image of the actual card content as read in (11 word rec. with the 11th word a LOOK AHEAD.)

3. Other actions

This is a class of one line BCD phrase briefly explaining the nature of the action. Examples:

TO MTCE CDSCCU
TO MODE 1 CSCCU
OUTPUT INHIBIT TIMING BUFFER

2.2.3 Upon termination of a history tape, another file of status will be written in the same format as defined in 2.2.1 of this document.

3. CARD FORMATS

The following cards pertain to either the Switch Control Program or both the Switch Control Program and the SCHOPS program, according to the following legend:

(S) = Switch Control Program only.
(B₁) = Both SCHOPS to Switch Control.
(B₂) = Both Switch Control to SCHOPS.

- 1.) Action card (S). This card is used by the Switch Control program for schedule overrides. The card can perform the function of adding, deleting, or replacing switch actions. For a deletion, only the month, day, and system time appear on the card.
- 2.) Schedule Tape Identifier Card (B₁). This card is punched by the SCHOPS program for use by the Switch Control program to insure that the correct tape is being processed.
- 3.) "Cards Only" control card (S). This card is used by the Switch Control program to allow switch actions directly from cards with no tape input.
- 4.) CHG card (B₂). This card is used to modify the equipment assignment tables within the switch control program. This modification will affect either the assignment of physical equipment to matrix points or the function of the physical equipment. For the next SCHOPS run, all available "CHG" cards are input to SCHOPS so that the equipment assignment tables output on the schedule

1 March 1963

-12-

TM(L)-832/000/01

tape will reflect, as closely as possible, the present configuration.

5.) SET and CLR cards (B₂). These cards are used to modify the equipment assignment tables within the Switch Control program so that switch failures can be distinguished from "Security Lockouts." These cards are input to the SCHOPS program to update equipment tables for the next schedule generation.

6.) Emergency Control card (S). This card is used by the Switch Control program whenever it is necessary to read in a "CHG", "SET" or "CLR" card.

Action Card

<u>Col.</u>	<u>Contents</u>									
1 - 3	blank									
4 - 5	month in decimal									
6 - 7	day in decimal, execution time for action									
8 - 12	system time in decimal, seconds									
13	blank									
14 - 79	free field containing three pieces of information anywhere in the field, separated by blanks and in the following order: <ol style="list-style-type: none"> (1) "C" or "D" connect or disconnect (2) designator of equipment <ol style="list-style-type: none"> (a) tracking station designators (give $1 \leq N \leq 9$) are <table border="0" style="margin-left: 40px;"> <tr> <td>VTS - N</td> <td>HTS - N</td> <td>IOS - N</td> </tr> <tr> <td>NHS - N</td> <td>TTS - N</td> <td>ATS - N</td> </tr> <tr> <td>FGS - N</td> <td>FNS - N</td> <td>KTS - N</td> </tr> </table> (b) 1604 designators (given $1 \leq N \leq 9$) are 1604-N (c) printer designators (given AN is "analysis", PR is "presentation", $1 \leq VVVVVV \leq 999999$ is vehicle number) are VVVVVV AN or VVVVVV PR (3) vehicle number of bird buffer (given $1 \leq VVVVVV \leq 999999$) is VVVVVV. 	VTS - N	HTS - N	IOS - N	NHS - N	TTS - N	ATS - N	FGS - N	FNS - N	KTS - N
VTS - N	HTS - N	IOS - N								
NHS - N	TTS - N	ATS - N								
FGS - N	FNS - N	KTS - N								
80	blank									

1 March 1963

-15-

TM(L)-832/000/01

"Cards only" Control Card

<u>Col.</u>	<u>Contents</u>
1 - 3	blank
4 - 5	month in decimal
6 - 7	day in decimal
8 - 12	seconds in decimal
13	blank
14 - 79	free field containing CARDS ONLY card label anywhere in the field.
80	blank

Switch Schedule Modification Card
(Change Card - CHG)

<u>Col.</u>	<u>Contents</u>									
1	"B"									
2	"3"									
3	blank									
4 - 79	<p>free field containing four or five pieces of information anywhere in the field, separated by blanks, and in the following order:</p> <p>(1) "CHG" change card indicator</p> <p>(2) designator of equipment to be changed</p> <p style="margin-left: 40px;">(a) Bird Buffer designators (given $01 \leq NN \leq 99$) are BB-NN</p> <p style="margin-left: 40px;">(b) tracking station designators ($1 \leq N \leq 9$) are</p> <table border="0" style="margin-left: 80px;"> <tr> <td>VTS - N</td> <td>HTS - N</td> <td>IOS - N</td> </tr> <tr> <td>NBS - N</td> <td>TTS - N</td> <td>ATS - N</td> </tr> <tr> <td>FGS - N</td> <td>FNS - N</td> <td>KTS - N</td> </tr> </table> <p style="margin-left: 40px;">(c) printer designators (given $01 \leq NN \leq 99$) are PR-NN</p> <p style="margin-left: 40px;">(d) 1604 designators (given $1 \leq N \leq 9$) are 1604-N</p> <p style="margin-left: 40px;">(e) vehicle numbers ($1 \leq VVVVV \leq 999999$) are VVVVV</p> <p>(3) the word "TO"</p> <p>(4) designator of status after change</p> <p style="margin-left: 40px;">a coordinate designators (given $01 \leq NN \leq 99$) are LINE NN</p> <p style="margin-left: 40px;">b the word "ON" or the word "OFF"</p> <p style="margin-left: 40px;">c vehicle number VVVVV or 000000 if the vehicle is unassigned.</p> <p>(5) The word "EQUIP" or the word "STATION"</p>	VTS - N	HTS - N	IOS - N	NBS - N	TTS - N	ATS - N	FGS - N	FNS - N	KTS - N
VTS - N	HTS - N	IOS - N								
NBS - N	TTS - N	ATS - N								
FGS - N	FNS - N	KTS - N								
80	blank									

1 March 1963

-17-

TM(L)-832/000/01

Switch Schedule Modification Card
(Security Set, SET and Security Clear, CLR)

<u>Col.</u>	<u>Contents</u>
1	B
2	3
3	blank
4 - 79	free field containing three pieces of information anywhere in the field, separated by zeros, and in the following order: (1) SET or CLR modification card indicator (2) first piece of equipment involved in the set or clear (a) 1604 designators (given $1 \leq N \leq 9$) are 1604-N (b) tracking station designators are as noted under Change Card (c) printer designators, ($01 \leq NN \leq 99$) are PR-NN (3) Second piece of equipment involved is bird buffer designated by BB-N ($1 \leq N \leq 9$)
80	blank

4 OPERATIONAL DEFINITIONS

4.1 Equipment: (Definition by enumeration)

Each Bird Buffer complex is an equipment.

Each CDC 1604 computer complex is an equipment.

Each Data Presentation 166 printer is an equipment.

Each Data Analysis 166 printer is an equipment.

The Multi-Ops 166 printer is an equipment.

Each pair of duplex 1200 bps lines linking the STA to an augmented half-station is an equipment.

4.2 Switch Coordinate:

Each switch (CDSCCU and CSCCU) has a number of "spigots" to which an equipment may be connected. Each "spigot" is identified by a number, called its coordinate. The coordinates of the spigots on the CDSCCU to which the 1200 bps lines may be connected are called "Y - coordinates;" those on the CDSCCU to which bird buffers may be connected are called "X - coordinates;" those on the CSCCU to which the bird buffers may be connected are called "X' - coordinates;" and, finally, those on the CSCCU to which the 1604 computers and 166 printers may be connected are called "Y' - coordinates."

4.3 Physical Equipment Identifier:

Each physical equipment has an associated identifier called its "physical equipment number." Each Bird Buffer complex has a unique physical equipment number of the form BB-r, where the r is a two-digit decimal number between 01 and 31, inclusive.

Each 1604 complex has a unique physical equipment number of the form 1604-s, where s is a single-digit decimal number between 1 and 9, inclusive.

Each of the printers in the combined data analysis, data presentation, and multi-ops areas has a unique physical equipment number of the form PR-t, where t is a two-digit decimal number between 01 and 54, inclusive.

Each pair of duplex, 1200-bps lines has a physical equipment number of the form XXX-u, where the XXX is a three letter mnemonic for the tracking station and the u is a single-digit decimal number between 1 and 3, inclusive. The XXX's are chosen from the set VTS, NHS, TTS, KTS, IOS, ATS, FGS, HTS, which correspond to Vandenberg, New Boston, Thule, Kodiak, Indian Ocean, Annette, Fort Greely, and Hawaii stations, respectively.

4.4 Functional Equipment Identifiers:

The role of each equipment in the system changes from time to time, depending on whether it is active or inactive (from a scheduling point of view) and depending on the vehicle with which it is associated. Temporally variable identifiers, called "functional equipment numbers," are therefore assigned to each equipment. For each active Bird Buffer, the number of the vehicle with which it is identified will serve as its functional equipment number; inactive Bird Buffers will all have functional equipment numbers of zero. Each active data-analysis printer will have a functional designator of the form v AN, where v is the vehicle number of the bird with which it is associated. Similarly, active data-presentation printers have functional designations of the form v PR. Inactive data-analysis or data-presentation printers are functionally designated with a functional equipment number of zero. 1604's and 1200-bps lines are functionally designated as "on" or "off," and are not given vehicle identities.

4.5 Arbitrary Equipment Number:

Each equipment is assigned a unique, arbitrary four-digit-octal, equipment number for ease in cross referencing. At any given time, there is a one-to-one relation between arbitrary and physical equipment numbers, (e.g., 134 corresponds to 1604-4), and that relationship may be maintained for as long as the set of available equipment remains invariant. Removal of an equipment releases the corresponding arbitrary equipment number for assignment to any equipment which may subsequently be added.

(last page)

SWITCH	Coordinates	Equipment Type	IDENTIFIERS		
			Physical Equipment Number (Examples)	Functional Equipment Number (Examples)	Range and Arbitrary Equipment Nos. (Octal)
Communications Data Select and Cross Connect Unit (CISCCU)	Y-Coordinate $1 \leq Y \leq 31$	Pairs of fully duplexed 1200-bps lines	NHS - 2 VTS - 1 IOS - 3	On Off	0001 - 0077
	X-coordinate $1 \leq X \leq 31$	BIRD	BB - 18 BB - 31 BB - 07	1234 6703 1145	0100 - 0136
	X'-Coordinate $1 \leq X' \leq 31$	BUFFERS			0137 - 0175
Computer Select and Cross Connect Unit (CSCCU)	Y'-Coordinate $1 \leq Y' \leq 63$	1604's	1604 - 3 1604 - 8	On Off	0176 - 0206
		Printers	Pr - 22 Pr - 03 Pr - 19	1234 PR 1234 AN 6703 AN	0207 - 0274
TABLE NAME		INDEX		ENTRIES	
TABLEIN		Arbitrary Equipment Number		Coordinate	
TABLEOUT		Coordinate		Physical Equipment Number Functional Equipment Number Arbitrary Equipment Number	

FIGURE 2 REFERENCE CHART

1 March 1963

M. Winsor
J. Winter
R. Wise
J. Wong
C. Zubris

Room
22156
24117
22085
Sunnyvale
24075

TM(L)-832/000/01

1 March 1963

TM(L)-832/000/01

	<u>Room</u>		<u>Room</u>
D. Allfree	24083	J. Kneemeyer	22088
J. Aldana	22131	R. Knight	22119
L. Alexander	22134	L. Kolbo	22155
N. Alperin	22153	J. Laughlin	24073
E. Armstrong	24123	J. LaVine	24093
C. Becerra	24082	H. Lewis	23010
D. Biggar	24118	J. Little	24088
R. Bilek	23007	F. Long	22156
L. Brenton	24103	J. Lytton	24077
B. Burke	24086	G. Madrid	22081
R. Burke	22158	G. Mahon	24089
R. Busch	22088	J. Marioni	24076
C. Bustya	22134	R. Marshall	22160
M. Champaign	22152	W. Martin	24127
C. Chiodini	24091	J. McKeown	23013
B. Ciaccia	24082	J. Milanese	22155
R. Clements	22109	J. Munson	22087
B. Cline	24127	G. Myers	22095
J. Cogley	22156	P. Nelson	24075
L. Conger	24088	L. Ngou	24127
P. Cooley	24086	M. Olson	22161
D. Crum	24105	L. Padgett	24110
L. DeCuir	24053	E. Patin	Sunnyvale
W. Derango	24082	D. Persico	24083
G. Dexter	25016	T. Polk	24113
R. Disse	23014	D. Reilly	24121
G. Dobbs	22116	A. Robinson	24132
W. Dobrusky	24065	M. Rockwell	24086
R. Dugas	22125	J. Schroeder	24124
R. Ellis	22131	R. Scott	24110
R. Ericksen	22113	C. Seacat	Sunnyvale
H. Feldstein	24128	H. Seiden	22126
C. Francis	25013	R. Shapiro	24110
M. Franks	24122	S. Shoel	23007
L. Friedman	22122	R. Skelton	22152
S. Gardner	25026	N. Speer	24086
V. Gergen	25014	E. Stone	24058
I. Greenwald	22094	M. Sweeney	25026
J. Haake	22153	W. Taber	22101
D. Henley	22094	T. Tennant	27029
C. Hill	22101	J. Thompson	24088
J. Hillhouse	22078	C. Toche	24121
H. Holzman	24065	R. Totschek	24120
G. Hudson	24126	A. Tucker	22109
R. Johnson	22125	A. Vorhaus	24076
P. Kastama	22076	M. Weinstock	22131
M. Katz	25014	S. Weems	22109
F. Kayser	24109	G. West	Sunnyvale
J. Keddy	24105	G. P. West	22116
D. Key	23013	H. Williams	22110
R. Keyes	24073	G. Wilson	24124

UNCLASSIFIED

System Development Corporation,
Santa Monica, California
SCHOPS/SWITCH CONTROL INTERFACE
DOCUMENT.
Scientific rept., TM(L)-832/000/01,
by M. A. Frank, 1 March 1963, 2lp.
(Contract AF 19(628)-1648, Space
Systems Division Program, for Space
Systems Division, AFSC)

Unclassified report

DESCRIPTORS: Satellite Networks.
Programming (Computers).

Describes SCHOPS (Scheduling Operations
Package) as a scheduling program

UNCLASSIFIED

designed and written for the CDC 1604,
which allocates the use of specified
pieces of equipment or equipment
complexes at the Satellite Test
Annex (STA) and remote tracking stations
for specific tasks on a temporal basis.
States that in performing this function,
SCHOPS assists the System Controller (SC)
in the resolution of conflicts in
demands for specific equipment and
provides other necessary information
for implementing the control of this
equipment. Also states that a primary
product of SCHOPS is a schedule of
resource allocations for a prescribed
scheduling period.

UNCLASSIFIED

UNCLASSIFIED