

63-3-2

62-1726
TT

CATALOGED BY ASTIA
AD NO. # 015

TRANSLATION

NONLINEAR APERTURE CORRECTION

By

G. V. Braude and I. N. Isayeva

FOREIGN TECHNOLOGY DIVISION

AIR FORCE SYSTEMS COMMAND

WRIGHT-PATTERSON AIR FORCE BASE

OHIO

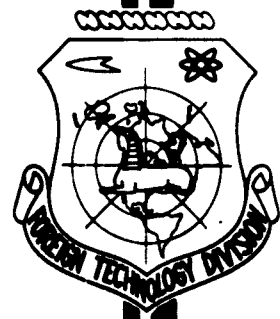

ASTIA
APR 19 1963
TJISA

UNEDITED ROUGH DRAFT TRANSLATION

NONLINEAR APERTURE CORRECTION

BY: G. V. Braude and I. N. Isayeva

English Pages: 15

SOURCE: Russian Periodical, Tekhnika Kino i
Televideniya, Nr. 12, 1961, pp 3-10

S/187-61-0-12-1-4

<p>THIS TRANSLATION IS A RENDITION OF THE ORIGINAL FOREIGN TEXT WITHOUT ANY ANALYTICAL OR EDITORIAL COMMENT. STATEMENTS OR THEORIES ADVOCATED OR IMPLIED ARE THOSE OF THE SOURCE AND DO NOT NECESSARILY REFLECT THE POSITION OR OPINION OF THE FOREIGN TECHNOLOGY DIVISION.</p>	<p>PREPARED BY: TRANSLATION SERVICES BRANCH FOREIGN TECHNOLOGY DIVISION WF-AFB, OHIO.</p>
---	---

Nonlinear Aperture Correction

by

G.V. Braude; I.N. Isayeva

Discussed is a method of aperture correction, which can be called a method of nonlinear aperture correction, equivalent in its action to the distribution of the signal into several levels with corresponding to each level, lying near the level of the black, incident frequency characteristic with its equivalent frequency band, and to each one of the levels, lying near the level of white, -frequency characteristic, having an ascend with its degree of aperture correction.

Correction of linear distortions of the TV tract, especially the so-called aperture correction leads. As is known, to a rise in the level of fluctuation interferences in the TV tract. The degree of aperture correction and the gain in image legibility connected with it is limited first of all by the increase in fluctuation interferences.

Foreign literature has published a report [1] in which is introduced a method of combatting the above mentioned limitation. This method consists in breaking up the TV signal into two levels, "from black to gray" and "from gray to white", with individual amplification of these two levels in two amplification channels, in one of which "from black to gray" no aperture correction is introduced, and in the second one, "from gray to white" the correction is introduced with subsequent combination of signals from these two amplification channels. The fluctuation interferences increase thanks to aperture correction only in luminous points of the image, where the interference effect of fluctuation interferences is particularly high. Image clearness

of dark details is lower than at an ordinary system of aperture corrections, which, ^{however,} has no substantial effect on the general visual perception of clearness of the entire image thanks to the low resolving power of the eye at poor illuminations.

The system, proposed in report [1] was reproduced by us and tested. These tests showed that in dividing the signal into two levels only the effect of improving the quality of the image, offered by the dividing system, is small and cannot justify the greater complexity and difficulty in adjusting the system. It can be assumed that the division of the signal into a greater number of levels with degree of aperture correction corresponding to each level would give a greater effect, but it would lead to an even greater, practically nonpermissible complexity of the system.

The circuit of the corrector, formulated by the method of nonlinear aperture correction, is shown in Fig. 1.

If we do not consider the nonlinear circuits contained in this system, circuits serving for the obtainment of a definite amplitude characteristic of individual parts of the corrector, then it will be analogous to the system of differential aperture correction, described in report [2].

In plate circuit of tube L_1 of the system is cut in a circuit consisting of three parallel branches: parasitic intercascade capacitance C_0 , plate resistance R and subsequent LC-of circuit. The voltage from this circuit is transmitted to the grid of tube L_3 of the system. On the other hand, the voltage from anti-induction of the L circuit, proportional to the second derivative of the input signal (v), is transmitted with the aid of tube L_4 , which amplified this voltage and transforms its phase, to grid of tube L_5 adding this voltage with a certain proportionality coefficient with the voltage, taken from the circuit in the general anode circuit of L_3 and L_5 tubes. Self-induction of the L circuit is shunted by a resistance T_{sh} , attenuating natural oscillations of a parasitic circuit, formed by this self-induction and input parasitic capacitance C_4 of L_4 tube. The magnitude of this resistance is deter-

mined by formula

$$R_n = \sqrt{\frac{L}{2C_1}} \quad (1)$$

When the circuit parameters are subjected to optimum frequency characteristic, presented in form of $C = 36_0$ and $R = \frac{\sqrt{9L}}{8C}$, the described system realizes a practically ideal aperture correction without phase distortions within limits of frequency band from zero to $\omega_{gr} = \frac{1}{\sqrt{18L}}$ in accordance with the law $\alpha = 1 + a\delta^2$, where $\delta = \frac{\omega}{\omega_{gr}}$ - relative frequency, a-correction coefficient, presented in form of $a = n \frac{S_5}{S_3} - 1$, where n - amplification factor of tube I_4 , S_5 - curvature of tube I_5 , S_3 - curvature of tube I_3 .

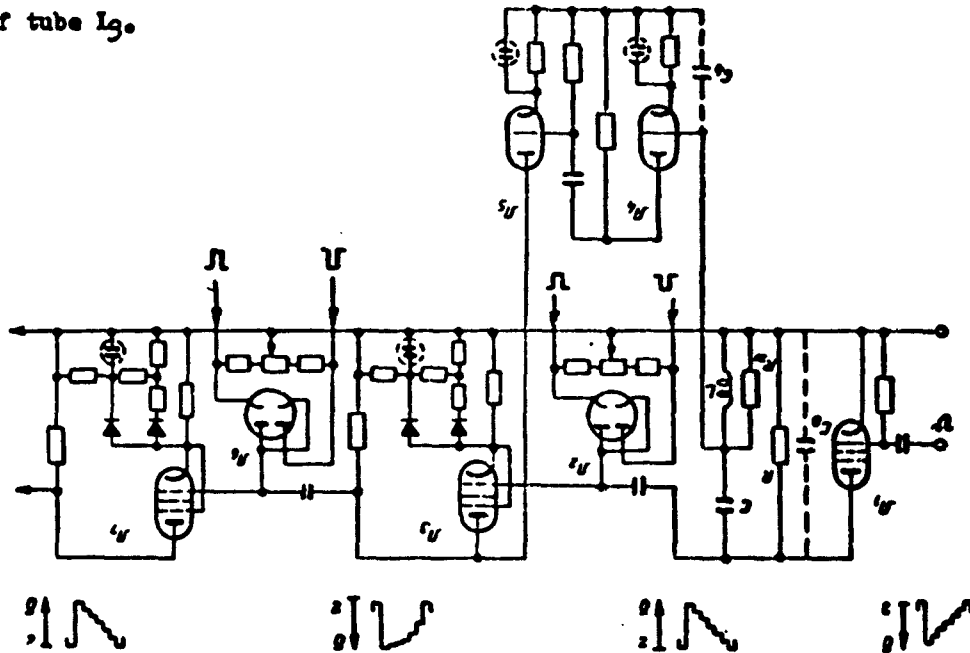

Fig.1. Schematic of the corrector

The expression given above for the coefficient a is valid for the discussed system of aperture correction and when considering the nonlinear circuits contained in the system, if under tube curvature we keep in mind its differential curvature in the corresponding point of tube's amplitude characteristic.

In the cathode circuit of tube I_3 is connected a system of crystal diodes and resistors, which forms by a known method a nonlinear resistance, decreasing

with the rise in potential of grid of tube L_3 in such a way, that the dependence of the plate current of this tube upon the potential of its grid, amplitude characteristic of tube, acquires the form, shown in fig.2, analogous to the one which is necessary for correction of gamma-characteristic of a receiving TV tube at a directed video signal (from black to white), designated in fig.1. The curvature of this dependence-differential curvature S_3 - decreases when changing over from black level to white level.

The necessary binding of the black level on the grid of tube L_3 is realized by the known controllable system of binding with the aid of a double diode L_2 .

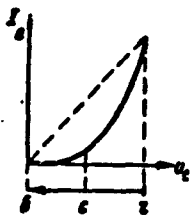

Fig.2. Dependence $I_a = f(U_c)$

Upon a change in the differential curvature S_3 it will be followed by a change in coefficient a . At a black level, when the value S_3 is maximum, the value a is minimum.

At very high values S_3 the coefficient a may acquire a value, close to -1 . In this case the frequency characteristic of the corrector will have the form of an incident curve $a = 1 - \delta^2$, acquiring the value 0 at $\delta = 1$, i.e. at $\omega = \frac{1}{\sqrt{LC}}$. At a distance from the black level, when value S_3 begins decreasing, the value of the coefficient will rise, and at a value $S_{30} = nS_3$ - the coefficient a will acquire zero value. The frequency characteristic of the corrector will have the form of a horizontal straight line $a = 1$.

When approaching the white level, at further reduction in differential curvature S_3 , the coefficient a , acquiring a positive value, will rise, reaching maximum value at the white level, where differential curvature S_3 acquires minimum value. There will be a maximum rise in frequency characteristic of the aperture corrector:

$$a = 1 + a_{\max} \delta^2, \text{ где } a_{\max} = n \frac{S_3}{S_{3\min}} - 1. \quad (2)$$

In this way, the nonlinearity of the amplitude characteristic of tube L_3 , entering the channel of the basic signal of the aperture corrector (aperture type compensator),

leads to the fact, that to each one of the signal levels, situated between the black level and the level of the signal, corresponding to differential curvature S_{30} , corresponds an incident frequency characteristic with its equivalent frequency band, and to each of the signal levels, situated between the level, corresponding to differential curvature S_{30} , and the white level, corresponds a frequency characteristic with its degree of rise - degree of aperture correction.

The level of fluctuation interferences will be correspondingly minimum at the black level and will reach maximum at the white level.

The described aperture corrector will bring in a certain nonlinearity into the TV tract. This nonlinearity, in spite of the fact that it is analogous to the one, which is necessary for the correction of gamma-characteristics of a receiving TV tube,^{but} cannot serve for the correction of this gamma-characteristic, because the form of the nonlinearity of the basic channel of the aperture corrector is determined not by the condition of optimum gamma-characteristic of the TV channel, but by the condition of optimum suppression of fluctuation interferences near the black level at optimum visual perception of image clearness. In order to obtain simultaneously an optimum gamma characteristic of the TV channel in sequence with the described aperture corrector, is connected a cascade of gamma-corrections, built around tubes L_6, L_7 . The action of tube L_7 is analogous to the action of tube L_3 in the channel of the basic signal of the aperture corrector, but it brings in into the video signal a nonlinearity of another sign, because the direction of the video signal on the grid of tube L_7 is opposite the direction of the video signal on the grid of tube L_3 .

In the special case, when the entire arrangement is faced with the requirement of linearity of amplitude characteristic, the cascade of gamma correction should bring in a nonlinearity, reverse to the one, brought in by the basic channel of the aperture corrector. Gamma of the entire arrangement will be equal to one. At a variation in nonlinearity of the gamma-correction cascade, gamma of the entire arrangement may be obtained greater than or smaller than one.

The entire arrangement at gamma, equal to one, appears to be an arrangement of nonlinear aperture correction in the sense of a nonlinear dependence of the coefficient of aperture correction α upon the level of the video signal.

To more sharply narrow the frequency band for video signal levels, situated near the black level, into the plate circuit of one of the amplification cascades to the described aperture corrector is connected a circuit, similar to the C_0RLC circuit, tuned to the very same or somewhat higher boundary frequency $\omega_{bound 1} \geq \omega_{bound}$.

The frequency characteristic of the nonlinear aperture corrector together with its amplification cascade at the black level approaches the form of $\alpha = (1 - \frac{\omega^2}{\omega_{bound 1}^2})$ X $(1 - \frac{\omega^2}{\omega_{rp1}^2})$, and at the white level it is presented in form of

$$\alpha = (1 - \frac{\omega^2}{\omega_{rp1}^2}) (1 + a_{max} \frac{\omega^2}{\omega_{rp}^2}) \quad (3)$$

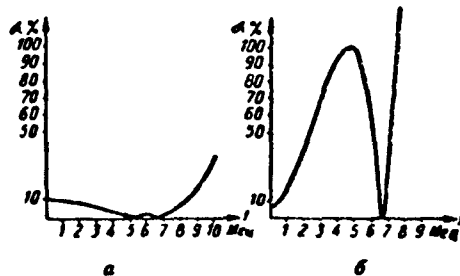

Fig.3. Theoretical frequency characteristics

In fig.3, a is given a frequency characteristics graph

$$\alpha = (1 - \frac{\omega^2}{\omega_{rp1}^2}) (1 - \frac{\omega^2}{\omega_{rp}^2}) \quad (4)$$

at $f_{bound} = 5$ mc and $f_{bound 1} = 6.7$ mc ($\omega = 2\pi f$).

In fig.3, b is given a frequency characteristics graph

$$\alpha = (1 - \frac{\omega^2}{\omega_{rp1}^2}) (1 + a_{max} \frac{\omega^2}{\omega_{rp}^2}) \quad (5)$$

at the very same values of boundary frequencies and $a_{max} = 27$.

If we should not consider the rise of the frequency characteristic beyond the limits of boundary frequency of 6.7 mc, cut around by the general frequency characteristic of the TV tract, then the first graph represents

and incident frequency characteristic with equivalent frequency band of the order of 3,5 ms, and the second graph represents a frequency characteristic, the initial and center sections of which have a rise, the form of which is practically determined by the second multiple of the frequency characteristic expression

$$\alpha = \left(1 - \frac{\omega^2}{\omega_{rpl}^2}\right) \left(1 + a_{max} \frac{\omega^2}{\omega_{ip}^2}\right). \quad (6)$$

The form of the last section of the graph is predominantly affected by the first multiple of the expression of the frequency characteristic, thanks to which the rise in frequency characteristic is being more and more slowed down, and the frequency characteristic, reaching maximum ($a = 10$) at a frequency of 4.9 ms, after which it drops sharply.

The frequency characteristics, corresponding to various levels of video signal, situated between black and white levels, are situated between the above mentioned graphs. It should be pointed out, that on the ascending as well as on the descending sections of the frequency characteristics there are practically no phase distortions, because the above described C_0RLC circuit has a phase characteristic, which within the limits of the frequency band ranging from zero to $\omega \sqrt{\frac{1}{LC}}$ deviates from the linear law by not more than 5° , and within the limits of frequencies ranging from zero to $\omega = 2 \sqrt{\frac{1}{LC}}$ it deviates from the linear law by not more than 18° .

It is interesting to compare the above described system of nonlinear aperture corrections with one of the possible systems of combining aperture and gamma corrections. Ordinarily are used in series connected aperture and gamma-correction systems whereby the aperture correction system is connected to a gamma-correction system. In some instances the aperture correction system is connected after preliminary gamma-correction.

It is also possible to have a scheme of parallel-connection of aperture and gamma corrections, as shown in fig.4, when gamma correction is made only in the basic channel of the aperture corrector, constructed by the method of combining the basic signal

and the signal of the second derivative. Such an arrangement of combining aperture and gamma corrections was tested during the development of a correction block for the video signal of a TV relay system [3], but it was rejected in view of greater frames (repeats) of TV images, which have been received at this arrangement.

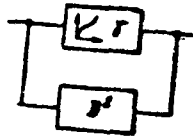

Fig.4. Scheme of parallel connection of aperture and gamma corrections.

It can easily be shown, that the parallel system, in this case, when gamma correction is made of the TV receiving tube only, appears to be a partial incomplete case of

nonlinear aperture correction. In this case there is also a nonlinear amplitude characteristic of the channel of the basic signal of aperture corrector, the curvature of which drops during the change over from black to white level, but the degree of this nonlinearity is insufficient to obtain a noticeable effect in reducing the visibility of fluctuation interferences in the black zone and in the gray zone in particular. But there should be no TV image distortions of frame type (repeats). In case when gamma correction is made not only in the receiving TV tube (in black zone) but also in the transmission TV tube (in white zone) and the general amplitude characteristic of the gamma corrector has the form of (as shown in fig.5) the above mentioned image distortions are possible. The fact is, the nonlinearity of the channel of the basic signal of the aperture corrector will in this case lead to a reduction in clearness in the white zone, since the curvature of the amplitude characteristic grows during transition from the gray to the white level. But upon the attainment of the necessary clearness in the white zone a recorection is necessary in the gray zone, causing blips in the transient characteristic, which do lead to frame type image distortions (repeats). Similar effects

in the above described nonlinear aperture corrector (see fig.1), naturally, do not take place even in the case, when the



Fig.5. Amplitude characteristic of gamma-corrector

gamma correction cascade contained in it is used for gamma correction of the transmitting TV tube (in white zone).

To experimentally investigate and test the effectiveness of nonlinear aperture correction was constructed an intermediate amplifier, which includes: nonlinear aperture corrector, constructed in accordance with the schematic in fig.1., amplification stage

to aperture corrector, to the plate circuit of which is cut in a circuit, similar to the C_0 RLC circuit of the nonlinear aperture corrector, and elements, inherent for an ordinary intermediate amplifier, serving for the formation of blanking pulses, etc. The entire principal arrangement of this intermediate amplifier is shown in fig.6.

Tubes L_3 L_{4a} L_{4b} L_5 L_6 L_7 L_8 of this system correspond to tubes L_1 L_4 L_5 L_2 L_3 L_6 L_7 of the system shown in fig.1. of the nonlinear aperture corrector. Tubes L_{1a} L_{2a} L_{2b} represent conventional video amplifier stages. Tube L_{1b} represents an above described amplification stage, to the plate circuit of which is connected a circuit, similar to a C_0 RLC circuit of a nonlinear aperture corrector. Tubes L_{14a} L_{14b} constitute an amplifier of horizontal sync pulses, serving to control the binding of the black level (built around tubes L_5 L_7). Tubes L_{13a} L_{13b} constitute the amplifier of blanking pulses, introduced into the plate circuit of tube L_8 and then limited by crystal diodes.

The level of limitation of blanking signal is controlled by the change in value of positive voltage on the diode plate, connected in series with anode resistor of tube L_8 , and on the cathode of the diode, connected in parallel to this resistor. Tube L_9 represents a video amplifier stage, in which with the aid of changing the magnitude of cathode resistance is realized control of the output value of the video signal; control of the input value of the video signal is realized as usually from the control desk.

Tubes L_{10} L_{11} L_{12} represent output cathode followers of intermediate amplifier, serving for the transmission of the video signal to the linear amplifier and to video control devices. Controlling the degree of aperture correction (HF-rise) is done

by changing the negative bias on the grid of tube L_{4a} . Controlling the degree of nonlinearity of the channel of basic aperture corrector signal is done by changing the value of positive voltages on the cathodes of crystal diodes, connected into the cathode circuit of tube L_6 . In this way is regulated the nonlinearity of the gamma corrector, built around tube L_3 .

In fig.7a and 7b are shown experimentally plotted (on ICHEK-57) graphs of frequency characteristics of this intermediate amplifier, corresponding to black (a) and white (b) levels. These characteristics by their form correspond fully to the theoretically calculated frequency characteristics of the device, shown in fig.3a and 3b.

The rise in frequency characteristics to beyond the limits of the second boundary frequency - 6,7 mc, determinable by the circuit in the plate circuit of tube L_{1b} , as already mentioned, is clipped by the general frequency characteristic of the TV

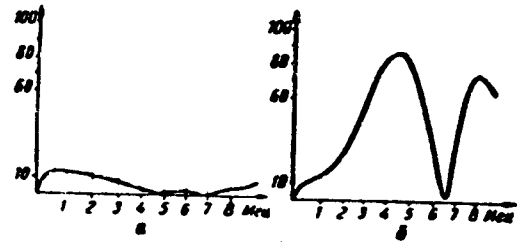

tract. But, keeping in mind the necessity of observing a TV image in the equipment room of the TV-center, the equipment of which, including also the video control devices, ordinarily have a much wider band of frequencies, than the general frequency band of the TV-tract, for the purpose of obtaining a proper idea about the nature of the image at the receiving end of the entire TV tract to the input of the intermediate amplifier was attached a low frequency filter, clipping the frequencies, lying above a frequency of 6 mc. The schematic of such a filter is shown in fig.8a. This filter was designed and constructed by the method, described by [4] so that at a band pass of 6 mc with a irregularity of 0.1 db the damping on a 6.5 mc frequency should be equal - 20 db.

Experimentally plotted frequency characteristics and delay time characteristics $\gamma = \frac{d\varphi}{d\omega}$ of this filter are shown in fig.8, b and c¹.

1. This filter was designed and constructed by engr. L. A. Levashova

Although phase distortions on frequencies, close to boundary, in such a filter are quite great, this is of no significant importance, because in the given zone of frequencies the frequency characteristic of the very intermediate amplifier with nonlinear aperture correction has already a great drop and the level of spectral components of the video signal in this range of frequencies, is very small, even at a larger extent of aperture correction, taking place at the white level.

In fig.9 (a₁, a₂, a₃) are shown the plotted in this way amplitude characteristics of the cascade built around tube L₆ (of basic signal channel) of nonlinear aperture corrector, plotted with the aid of a "step generator" at various nonlinearity degrees of this cascade. The lower stages adhering to black level, are here more or less stretched, and the upper stages, adhering to the white level, more or less compressed.

In fig.9.(b₁, b₂, b₃) have been plotted amplitude characteristics of tube L₃ of the gamma corrector, intended for correcting linearity of aperture corrector and for the obtainment of the given gamma of the entire installation. The linear amplitude characteristic of the entire installation is obtained approximately by combining the nonlinearity of the aperture corrector, corresponding to fig. 9, a₂ and the nonlinearity of gamma corrector, corresponding to fig.9, b₃.

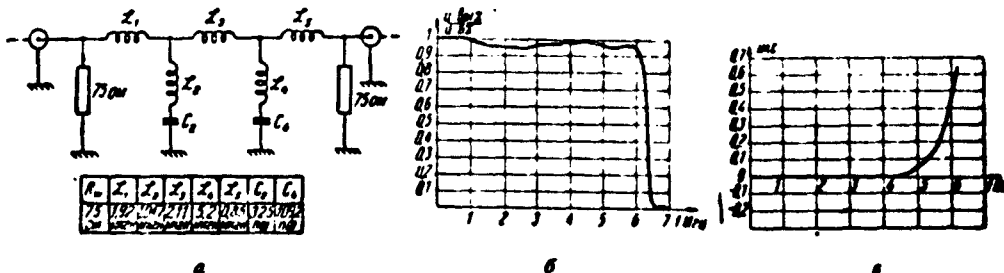

Fig.8. Schematic of the 6 mc filter (a) its frequency characteristic (b) and time delay characteristic (c).

The above described intermediate amplifier with nonlinear aperture correction

was tested in a vidicon motion picture channel of the Moscow TV center. To make a comparison was tested also the intermediate amplifier with in-series combining the linear aperture corrector and gamma corrector.

Testing the intermediate amplifier with linear aperture corrector showed, that combined application of ordinary linear aperture correction with gamma-correction cannot raise the quality of the image because of the sharp increase in fluctuation interferences during the introduction of aperture and gamma corrections as well. And in a normal vidicon motion picture channel, employed by the Moscow TV-center, in which there is no gamma correction and only linear aperture correction is used, the fluctuation interferences, particularly noticeable in black and gray zones, do not give the possibility of employing higher

degrees of aperture correction, necessary

for the obtainment of an image of greater clearness.

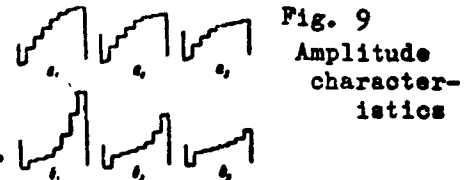

Fig. 9
Amplitude
character-
istics

Tests of the above experimental intermediate amplifier showed, that the introduction of a nonlinear aperture correction, at a greater degree of nonlinearity, substantially raises the quality of the TV image, increasing the number of brightness gradations and improving the clearness of the image. At a sharp reduction in fluctuation interferences in the black and gray zones- practical disappearance of same, drop in image

clearness in dark and gray places of the image in real subjects of various plan was practically unnoticeable. At the same time the image clearness in bright spots of the image has risen sharply and in spite ^{that the/} fluctuation interferences in the bright spots are becoming noticeable, they had an ordered nature in form of a screen corresponding to a frequency of 5 mc. (frequency with frequency characteristic maximum of the device at the white level), which interferes very little with the observation of the image.

It can be assumed that the use in a preliminary amplifier of a complex system of an anti-interference correction [5, 6] with cut out frequency of the order

of 5 mc should in these conditions sharply reduce the visibility of the above mentioned interference-screen and additionally improve the quality of the TV image.

Literature

1. Sullivan M., Highlight Equalizer Sharpens TV Pictures, Electronics, 1958, vol. 31, No. 3.
2. Braude G.V; Makarov Yu.S; New System of Differential Aperture Correction, Tekhnika Kino i Televideniya. No.6, 1961
3. Gisich P.N; Levashov, V.S; Pokrovskiy, I.P; Apparatus for the Correction of TV Signal and for Increasing Its Interference Resistance. Televideniye, Priyem i Retranslatsiya No.9, 1958.
4. Alexander, Grossman I., Synthesis of Tchebycheff Parameter Symmetrical Filters, Proceedings of the I. R. E., April, 1957.
5. Braude G.V. Method of Complex Antinoise Correction, I.E.S.T. No.6, 1941
6. Braude G.V; Ushakov, M.A; Preliminary Amplifier of TV Motion Picture Channel Tekhnika Kino i Televideniya No 3, 1957

State Scientific Technical Institute of the Ministry of Communication USSR

DISTRIBUTION LIST

DEPARTMENT OF DEFENSE	Nr. Copies	MAJOR AIR COMMANDS	Nr. Copies
		AFSC	
		SCFDD	1
		ASTIA	25
HEADQUARTERS USAF		TDETL	5
		TDEDP	5
AFCIN-3D2	1	SSD (SSF)	2
ARL (ARB)	1	APGC (PGF)	1
		ESD (ESY)	1
OTHER AGENCIES		RADC (RAY)	1
		TDEEC	1
CIA	1		
NSA	6		
DIA	9		
AID	2		
OTS	2		
AEC	2		
FWS	1		
NASA	1		
ARMY	3		
NAVY	3		
PGE	12		
RAND	1		