

**UNCLASSIFIED**

---

**AD 401 779**

*Reproduced  
by the*

**DEFENSE DOCUMENTATION CENTER**

**FOR**

**SCIENTIFIC AND TECHNICAL INFORMATION**

**CAMERON STATION, ALEXANDRIA, VIRGINIA**



---

**UNCLASSIFIED**

NOTICE: When government or other drawings, specifications or other data are used for any purpose other than in connection with a definitely related government procurement operation, the U. S. Government thereby incurs no responsibility, nor any obligation whatsoever; and the fact that the Government may have formulated, furnished, or in any way supplied the said drawings, specifications, or other data is not to be regarded by implication or otherwise as in any manner licensing the holder or any other person or corporation, or conveying any rights or permission to manufacture, use or sell any patented invention that may in any way be related thereto.

63-32

AID Report F-63-38

20 March 1963

401779

CATALOGED BY ASTIA  
AS AD No. \_\_\_\_\_

401779

**SOVIET LITERATURE ON PROTECTIVE STRUCTURES  
AND COMPONENTS**

**Review of Literature**

**AID Work Assignment No. 13**

ASTIA  
RECORDED  
APR 18 1963  
TISIA A

**Aerospace Information Division  
Library of Congress**

**Best  
Available  
Copy**

AID Report P-63-38

20 March 1963

**SOVIET LITERATURE ON PROTECTIVE STRUCTURES  
AND COMPONENTS**

Review of Literature

AID Work Assignment No. 13

The publication of this report does not constitute approval by any U. S. Government organization of the inferences, findings, and conclusions contained herein. It is published solely for the exchange and stimulation of ideas.

Aerospace Information Division  
Library of Congress

## FOREWORD

This is the seventh in a report series reviewing Soviet literature on ground support equipment. It is based on materials received by the Aerospace Information Division prior to 28 December 1962. The report series, which is prepared quarterly in conformance with AID Work Assignment No. 13, has hitherto dealt with the following topics:

- I. Operational Employment and Philosophy
- II. Missile Data
- III. Facilities
- IV. Transport
- V. Launch Site
- VI. Ground Support Equipment
- VII. Natural Environmental Conditions
- VIII. Personnel

Beginning with the present report, the following additional areas of interest will be covered:

- IX. Research and Development Facilities
  - A. Missiles
  - B. Space vehicles
  - C. Support equipment
  - D. Supporting technologies
- X. Packaging, Preservation, and Storage
  - A. Packaging
    1. Crates
    2. Containers
    3. Identifying features
  - B. Preservation
    1. Techniques
    2. Environment
  - C. Storage
    1. Facilities
    2. Environmental control
    3. Methods to extend storage life

It is anticipated that these new topics will provide additional material for Task 541309 by indentifying and reporting information not currently covered under Work Assignment No. 13. The present (seventh) report contains materials relevant to topics III, IV, V, and X.

A list of the references cited accompanies the text. Library of Congress call numbers are included at the end of the source entry when the source is available in the collections of the Library of Congress.

TOPIC III. FACILITIES

A2 Configuration-- Buildings

Muzhichkov, N. I. Construction of a crane shop.  
 Promyshlennoye stroitel'stvo, no. 6, 1962, 8-10.

Construction of the crane shop of the Uzlovskiy mashino-  
 stroitel'nyy zavod (Uzlovaya Machinery Plant), begun during the  
 latter part of 1959, was completed during the first quarter of 1961.  
 The structure covers a total area of over 28,100 m<sup>2</sup> and encloses a  
 volume of about 400,000 m<sup>3</sup>. The (shop) building (See Fig. 1) has

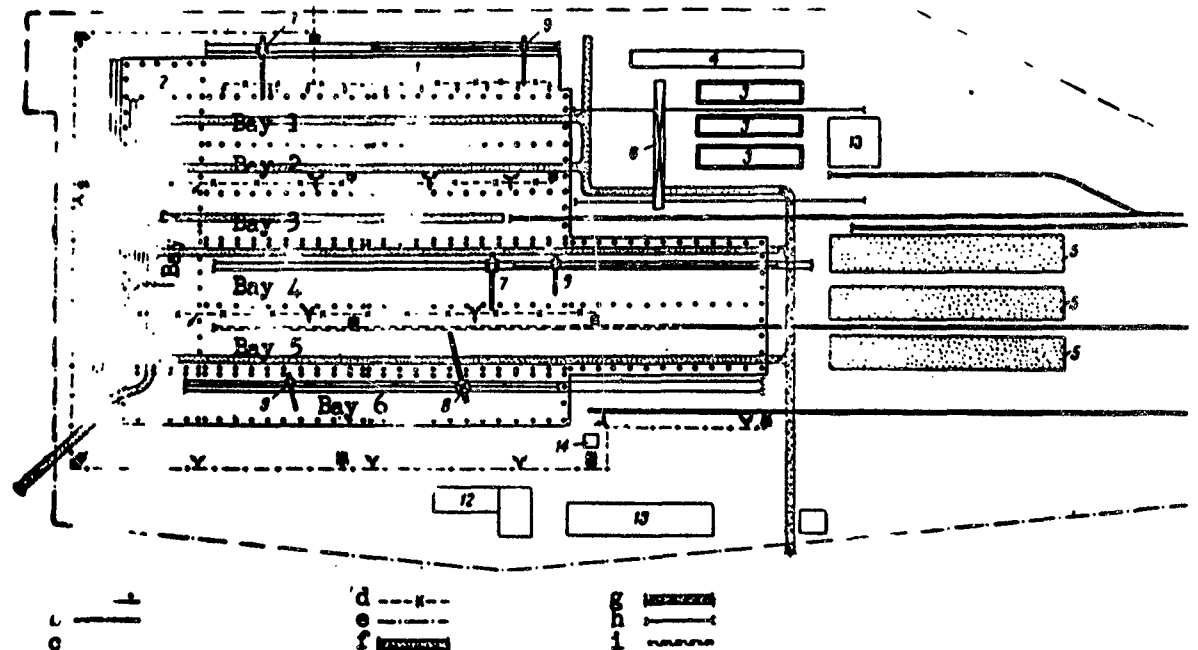

General construction plan for period of foundation construction of plant

a - building walls; b - permanent railways; c - temporary electrical  
 network; d - cable; e - permanent fence; f - truck access; g - per-  
 manent roads; h - rotary crane rails; i - temporary railway; l - living  
 quarters; 2 - heat-treatment shop; 3 - steam chambers; 4 - drum wind-  
 ing area; 5 - storage areas; 6 - gentry crane; 7,8 - BKCM-5-5A  
 cranes; 9,10 - BK-1.5 cranes; 11 - C-419 crane; 12 - office and  
 storage; 13 - open storage area; 14 - cement mixer.

four bays 18 m long, two bays 24 m long, and one bay 30 m long. Each bay is equipped with travelling electric cranes: 5- to 10-ton cranes with a floor-to-crane-railhead clearance of 8 m in the 18-m bays; a 30-ton crane with a clearance of 10 m in the 24-m bays; and a 50-ton crane with a clearance of 12 m in the 30-m bay. In addition, the 30-m bay is furnished with 5-ton rotary cranes. The prefabricated reinforced concrete columns are set on monolithic reinforced concrete foundations; the foundations of the walls and partitions are also made of prefabricated reinforced concrete. The beams supporting the cranes in the 24- and 30-m bays are made of metal. Those in the 18-m bays are made of prefabricated reinforced concrete.

### B3 Construction-- Equipment

Astakhov, A. I. Reliable machines for construction projects in the North and in Siberia. Stroitel'nyye dorozhnyye mashiny, no. 3, 1962, 9-12.

Results of construction equipment investigations conducted in 1961 by NIIOMTP (Scientific research institute for the organization, mechanization, and technical assistance of construction) and VNII-Stroydormash (All-Union scientific research institute of construction and road machinery) showed that the utilization of equipment in northern regions (Magadan and Yakutsk economic regions) remains at a low level. This low utilization coefficient is explained by the fact that equipment such as Э-651, Э-652, and Э-1252 excavators, С-80 tractors, and Д-271 bulldozers are operating under difficult climatic and terrain conditions and possess design deficiencies which make proper maintenance difficult at low temperatures. The following are among the deficiencies noted in the currently available equipment: servicing and maintenance is difficult and time consuming; large numbers of lubrication points must be greased by hand; the machines are difficult to start; parts have a low wear resistance; and the strength of metal components of working members is inadequate at low temperatures. The bulk of the construction machinery shipped to construction sites in the North and in Siberia does not meet the expected requirements. Measures recommended to correct this situation include increased quality of manufacture, greater impact strength, simplification of servicing and maintenance, and prestart block heating.

#### TOPIC IV. TRANSPORT

##### B3 Road-- March order

Akhmet'yev, L. N., and K. Ye. Nikul'shin. New heavy-duty trailer. Stroitel'nyye i dorozhnyye mashiny, no. 10, 1962, 9-10.

The Central Design Bureau of the Administration for Mechanization, under the Ministry for Construction RSFSR, had designed a new universal heavy-duty trailer (model 4 IT-60) which is characterized by increased trafficability and a load-carrying capacity of 60 tons. The trailer is intended for use in transporting electrical equipment, transformers, machine tools, and engineering equipment, as well as excavators, cranes, and other machinery of up to 60 tons gross weight. It consists of a platform with holding stakes suspended between two interchangeable 8-wheeled carriages. To facilitate loading and unloading, the platform may be raised and lowered while fully loaded from 100 to 400 mm above the road surface. This feature also permits loads to be moved under low-clearance overhead structures such as bridges and tunnels. The design also permits lateral movement of the platform. The carriages are equipped with 15.00-20" wheels having a tire pressure of 4.5 kg/cm<sup>2</sup>. The wheel and brake systems of the 4 IT-60 trailer are patterned after those of the KpA3-214 tractor, which is used with it as prime mover. On class I and class II roads the HA3-210 tractor is used. The tractor-trailer (HA3-210 with 4 IT-60) attained a maximum speed on level highway of 40 km/hr. On city roads the vehicle attained speeds of 25 to 30 km/hr. Minimum turning radius is 10 m.

##### C1 Rail-- Rail cars

Bodnar, V. V. 220-kv power transformers for the Bratsk hydroelectric power station. Vestnik elektropromyshlennosti, no. 7, 1962, 6-8.

The TAU-275000/220 275-Mv-amp transformer, the largest in the USSR, is the first of its kind having 220-Kv cable lead-ins. Despite the quite considerable size of the unit, it was possible to transport the transformer by rail in its own container. In order to retain optimum (from the standpoint of electric parameters) geometrical proportions in the transformers, it was decided even as they were being designed to move them from the place of manufacture to the Bratsk GES (Hydroelectric station) on segmented-type rail transporters (see photo, next page).



ТДЛП transformer aboard transporter

This method of transport is quite new to the experience of Soviet transformer builders. In view of the great distances to be covered, as well as the traffic density on the trans-Siberian railroad, it was necessary to move the transformer at speeds comparable to those of freight trains. Furthermore, to make it easier to inspect and maintain the transformers without hoisting their working parts out of the container, the latter had to be designed to open as close to the bottom of the unit as possible. All these considerations increased the design requirements for the mechanical strength of the container, which, becoming an actual part of the transporter during shipment, was subjected to all sorts of stresses.

Langner, Karol. Model 606-Z 16-axle transporter for  
outrsize loads. *Przegląd kolejowy mechaniczny*, v. 14,  
no. 2, 1962, 49-52.

A transporter similar to that just described, and operating on the same principle, has been developed in Poland. According to Langner, Polish railroad rolling stock includes a number of prewar transporters with depressed central sections and more than a dozen transporters built since WW II, but only one sectional 170-ton transporter for moving transformers. Lack of a transporter suitable for moving the 210-ton 200,000-kw generator manufactured by the Khar'kov "Elektrot'yazhmash" for the Turów Electric Station prompted the development of the Model 606-Z 16-axle transporter, capable of negotiating both wide- and standard- (1524- and 1435-mm-) gage track. The transporter, which is of welded construction, consists of two

carriages supporting a load-carrying bridge. Each carriage consists of two 4-axle bogies joined by a frame resting on central pivoting

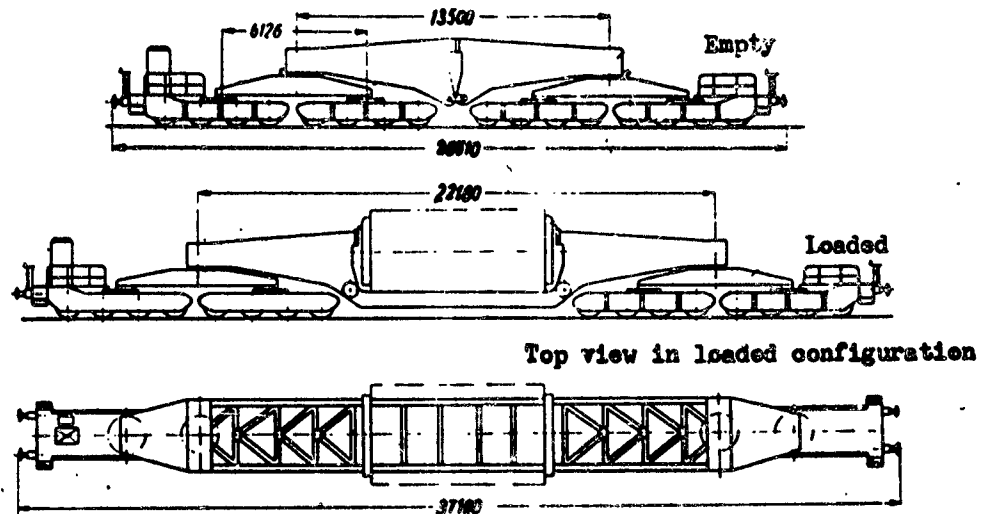

Fig. 1. Overall views of the Model 506-Z transporter in empty and loaded configurations

supports on the bogies. These supports are equipped with telescoping hydraulic jacks capable of lifting the bridge 250 mm fully loaded. Provision was also made for a screw-type jack on the load-securing

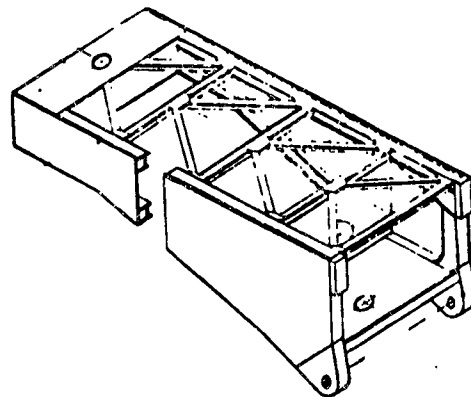

Fig. 2. Load-supporting bridge

ends of the bridge sections, for adjusting the height of the bridge during loading. The generator is secured at each end to the bridge halves by a shield bolted to the bottom of the stator. As shown in Fig. 1, the upper part of the generator rests directly against the upper bridge brackets, while the bottom part with the shield is supported by a special frame which joins the two halves of the bridge at the bottom. In this way it is possible to avoid placing any stress on the "body" of the generator. The shield is equipped with threaded bushings with screws to insure that the generator will rest uniformly on it, and has adjustable screw-type supports to hold the generator in any desired position.

The bottom-frame and shield method of loading can only be used for a certain type of generator. The bridge halves are coupled together when the transporter is empty. Load-carrying bridges and carriage frames are made of 18G2A steel. Elements bearing smaller loads use type St3S steel. The production of the special elements has been assigned to the Chorzow Plant (Wytownia Konstrukcji Stalowych). The production of the carriages has been entrusted to the Opole Plant (Zaklady Naprawcze Taboru Kolejowego). The specifications of the Model 60C-Z transporter are as follows:

Track gage	1435 and 1524 mm
Number of axles	16
Diameter of wheels	940 mm
Load-carrying capacity	
on category A rail lines	166 tons
on category B rail lines	198 tons
on category C rail lines	230 tons
Length of empty transporter (including bumpers)	28.51 m
Length of loaded transporter (including bumpers)	37.19 m
Load per running meter of track, empty	3.24 tons
Load per running meter of track, loaded	8.6 tons
Minimum turning radius	90 m
Maximum speed	80 km/hr

#### Water

Pozhitkov, V. I. Transport of outside equipment by water. Montazhnyye i spetsializirovannyye raboty v stroitel'stve, no. 11, 1962, 16-20.

The location of the majority of Soviet industrial complexes either on or near navigable waterways has prompted the Soyuzprombummontazh (State All-Union Trust for the Installation of Equipment for the Cellulose-Paper Industry) to use either barges or "flotation" in shipping outside equipment from manufacturer to place of use. Among considerations prompting this approach were the following: 1) Equipment with diameter greater than 3.78 m (maximum clearance) cannot be shipped by rail. 2) Disassembly of equipment for shipment and reassembly at the destination is quite difficult, and reassembly under field conditions cannot always meet the standards set by engineering requirements. Some data

on the size of digester tanks moved by water, number of units shipped, points of origin and destination of the shipment, and the mode of transport used are given in the table on the following page. The map shows the routes used for these shipments. The route used to float the first two tanks was as follows: from Odermünde via the Oder River, Baltic Sea, Gulf of Finland, the Port of Leningrad, Neva River, Mariinsk Waterway, and Lake Onega to the landing dock of the Kondopoga Cellulose-Paper Complex. The other two digesters

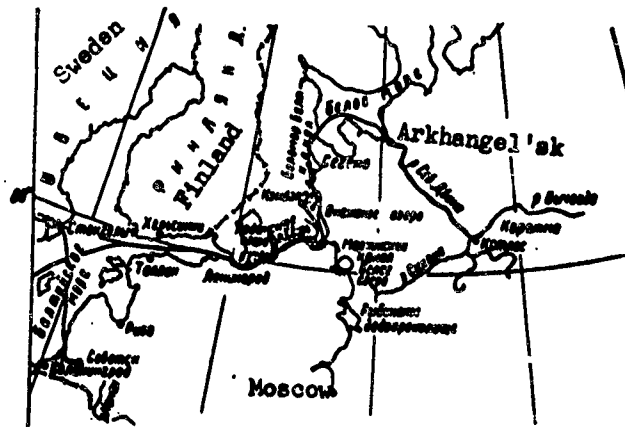

Waterways used in transporting outside equipment

were taken down the Oder River to the Baltic Sea and up the Pregolya River to the landing of the Kaliningrad Cellulose-Paper Complex. Obviously, these digester tanks were fully waterproofed prior to launching. Figure 1 shows the manner in which all 16 of the digester tanks purchased in Stockholm were waterproofed and rigged to make them sea worthy. Because of low water in the Vycheгда River, digesters intended for the Kotlas Cellulose-Paper Complex were loaded aboard barges after reaching Arkhangel'sk and secured as shown in Fig. 2. The digester tanks were towed across the Baltic by Soviet steamers using nylon tow ropes. In 1960, Finland manufactured six 110-m<sup>3</sup> bimetallic digester tanks for the Soviet Union. These were shipped to Pitkyaranta on self-propelled barges.

[Text continues on p. 9.]

Summary data on shipment of digesters

Type and parameters of equipment	Number of Units	Location		Date	Mode of Transport
		Origin	Destination		
Digester, rivetted vol, 280 m <sup>3</sup> Ø, 6.5 m lgth, 16 m wt, 103 t	2	Odermünde (GDR)	Kondopoga ЦБК	1945	flotation
Ditto	2	ditto	Kaliningrad ЦБК	1946	flotation
Digester, welded, bimetallic vol, 320 m <sup>3</sup> Ø, 6 m lgth, 16 m wt, 90 t	10	Stockholm (Sweden)	Kotlas ЦБК	1958	floated to Arkhangel'sk, thence by barge
Ditto	4	ditto	Arkhangel'sk ЦБК	1959	flotation
Ditto	2	ditto	Sevetsk ЦБК	1960	flotation
Digester, welded, vol, 110 m <sup>3</sup> Ø, 4 m lgth, 12 m wt, 22 t	6	Helsinki (Finland)	Pitkyaranta ЦЗ	1960	by barge
Digester, Kaymut system vol, 360 m <sup>3</sup> Ø, 4 m lgth, 32 m wt, 100 t	2	ditto	Kotlas ЦБК	1961	flotation
Ditto	2	ditto	Segezha ЦБК	1962	flotation
Digester, welded vol, 110 m <sup>3</sup> Ø, 3.6 m lgth, 14 m wt, 40 t	6	Ural-tyazh-mash	Solombala ЦБК	1960	flotation

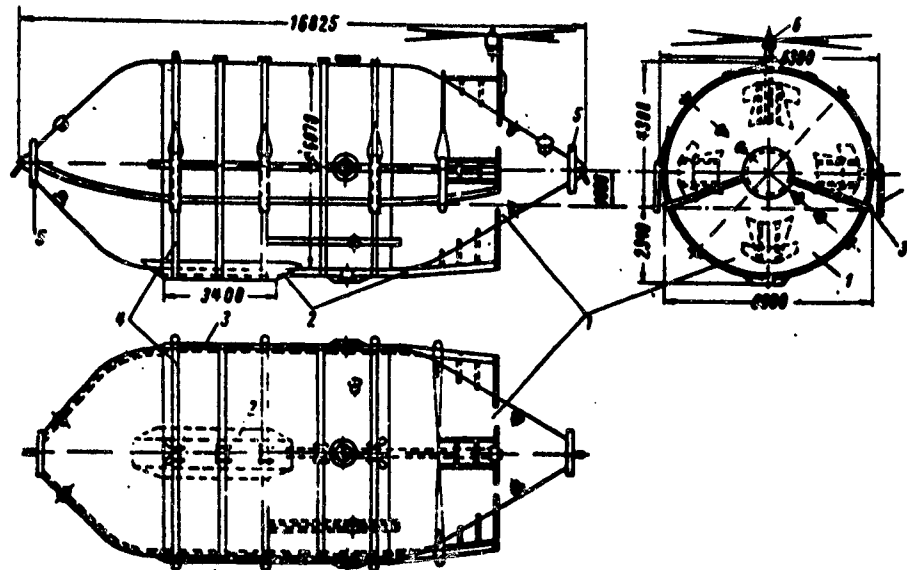

**Fig. 1. Fitting out digester tanks for flotation transshipment**

1 - digester; 2 - keel for stabilization; 3 - bumpers for mooring; 4 - bands holding keel and bumpers in place; 5 - neck plugs with rings; 6 - running light; 7 - shock-absorbing bumpers.

The barges each had two 50-ton derrick cranes to facilitate loading and unloading. Figure 3 shows the method used to float a 32-m-long digester tank from Helsinki to Kotlas. This tank was floated from Helsinki by the Gulf of Finland, the Port of Leningrad, the Neva River, Lake Ladoga, Svir River, Mariinsk Waterway, Lake Onega, and the Belomorskoy (White Sea) Canal to Arkhangel'sk; and then by the Severnaya Dvina and Vychegda Rivers to the Koryashma landing.

[See Figs. 2 and 3 on following page.]

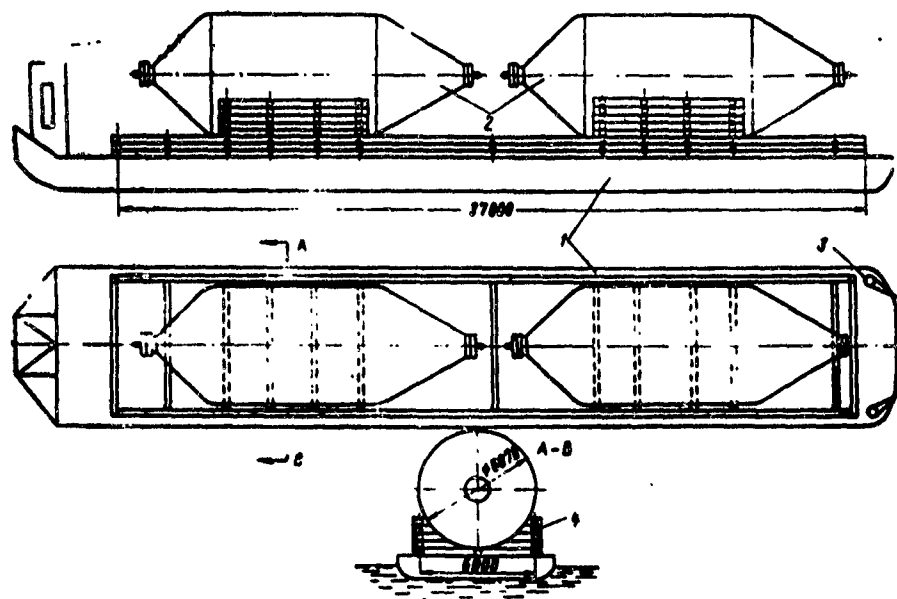

Fig. 2. Scheme of loading digester tanks on barges

1 - 600-ton barge; 2 - 90-ton digester tank;  
3 - tugboat line; 4 - wooden cradle holding  
digester tank.

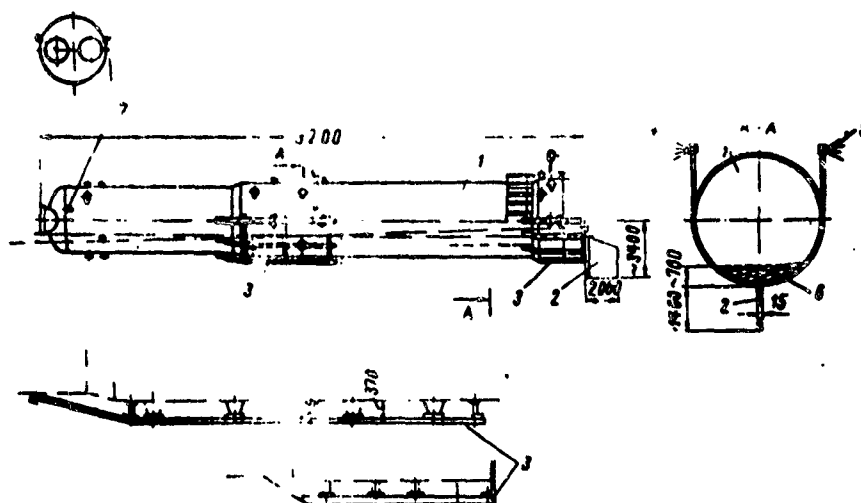

Fig. 3. Fitting out 32-m-long digester tank for flotation transshipment

1 - tank; 2 - centerboard keel mounted on base of tank;  
3 - metal sheathed bumper timbers to protect protruding  
pipe fittings of tank; 4, 5 - green and red running lights;  
6 - sandbag ballast; 7 - towing ring.

## TOPIC V. LAUNCH SITE

### E6 Accessories-- Gantries or Structures

Blokhnin, L. G., and A. V. Gorazhankin. New ДЭК-50 erection crane. *Stroitel'nyye i dorozhnyye mashiny*, no. 10, 1962, 1-3.

In 1961 the Chelyabinsk Engineering Plant of the Ministry of Electric Power Station Construction built an experimental model of a self-propelled diesel-electric caterpillar crane, the ДЭК-50, having a weight-lifting capacity of 50 tons. Depending on the type of work, this crane (see figure) may be equipped with 15-, 30-, and 40-m booms, with or without a 10-m boomlet. When used as a turret crane, it can also carry a 30-m boom with a 25-m boomlet. The design incorporates standardized components, part and assemblies, reduction gears, and so forth. One of the features of this crane is its "self-loading capability" when it is being transported by railroad flatcar. Loading, disassembly, and unloading may be accomplished by the crane itself without the aid of any additional equipment.

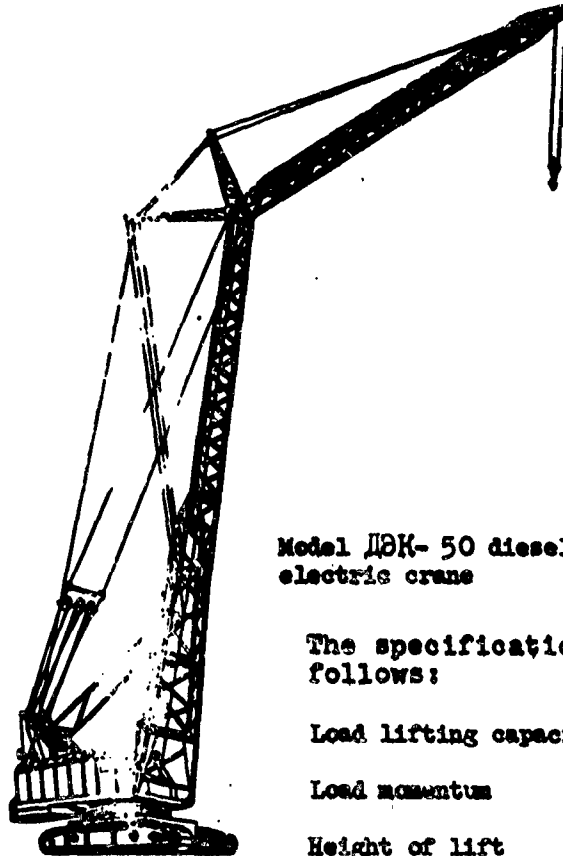

Model ДЭК-50 diesel-electric crane

The specifications of the ДЭК-50 crane are as follows:

Load lifting capacity	50 tons
Load momentum	300 ton meters
Height of lift	up to 50 m

Lifting speed	
with 15-m boom	5.1 m/min
with 40-m boom	15.4 m/min
Speed of crane travel	0.68 km/hr
Turning speed	0.3 rpm
Dimensions	
width of the turning part	3.24 m
width of crane (including tracks)	5.00 m
maximum height without boom	7.19 m
Average pressure on soil with maximum load	1.75 kg/cm <sup>2</sup>
Total capacity on electric motors	134.5 kw
Diesel power (VI Д6-150 diesel)	150 hp
Weight	
with 15-m boom	89.1 tons
with 10-m boom	94.6 tons

Bol'shunov, F. F., and Ye. M. Sidorov. Machine for mechanization of installation operations in the electrification of railroads. *Transportnoye stroitel'stvo*, no. 9, 1962, 18-21.

A truck-mounted jointed maintenance tower (see figure) has been designed by the Uglich Engineering and Repair Plant. The tower, which is mounted on the chassis of a 3M-157 truck, is intended for installation and repair operations at heights up to 17.8 m.

Specifications of the MHTC-2 maintenance tower are as follows:

Maximum sweep of the boom	15.4 m
Maximum height of lift to the basket	17.8 m
Length of tower sections	
upper leg	10 m
lower leg	6 m
Total weight lifting capacity of the basket	400 kg
Angle of rotation of the boom in horizontal plane	360°
Working speeds	
basket lift	20 m/min
boom rotation	0.6 to 1.0 rpm

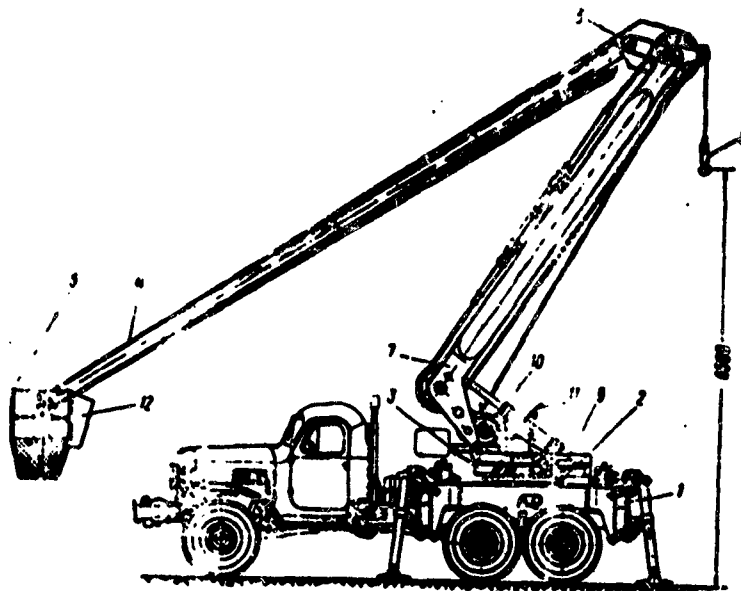

Model MUITC-2 truck-mounted maintenance tower

1 - support braces; 2 - support pivot of revolving base;  
 3 - revolving platform; 4, 7 - upper and lower legs of  
 jointed tower; 5 - basket-platform for workman; 6 - servo-  
 stabilizer to keep platform in upright position; 8 - derrick  
 hook; 9 - revolving platform mechanism; 10 - derrick winch;  
 11, 12 - control panels.

Road speed	15 to 40 km/hr
Pulling force of the wind rope	up to 5 tons
Maximum load capacity of the hoisting unit on the lower leg at a radius of 5.6 m	2000 kg
Maximum allowable wind pressure during operation	15 kg/m <sup>2</sup>
Maximum allowable wind velocity	10 to 12 m/sec
Overall dimension when travelling	
length	10.725 m
width	2.7 m
height	3.235 m
Total weight	12,100 kg

Giant cranes. Izvestiya, 5 Oct 1962, 3.

A self-propelled crane capable of hoisting a 50-ton load to a height of 9 m was built following the design of the Promstal'-konstruktsiya (Design and Planning Office of the Main Administration for the Building and Installation of Prefabricated Steel Structures) of the Ministry of Construction RSFSR. This crane is equipped with multiple speed winches and features a three-legged gantry, which considerably reduces the weight of the crane. The Institute is completing the design of a caterpillar crane which will be able to lift 100-ton loads to a height of 60 m, within a radius of 35 m.

TOPIC X. PACKAGING, PRESERVATION, AND STORAGE

A2 Packaging-- Containers

Sitnik, M. D. The development of container shipping and the choice of container types. *Zheleznodorozhnyy transport*, no. 7, 1959, 51-57.

Firsov, S. I. New freight containers for railroads. *Byulleten' tekhniko-ekonomicheskoy informatsii*, no. 9, 1960, 66-68.

A survey of types of Soviet containers available in 1959 shows that about 97% have a 2.5-ton capacity, while about 3% have a 5-ton capacity. Fig. 1 shows a 5-ton all-metal container, Fig. 2 a 2.5-ton all-metal container, and Fig. 3 a 2.5-ton wooden container. The inadequate size of these units prompted a study of new types specially designed to achieve optimum utilization of existing transport facilities. The proposed new units are shown in Figs. 4 through 7. Specifications of the new container types are given in the table.

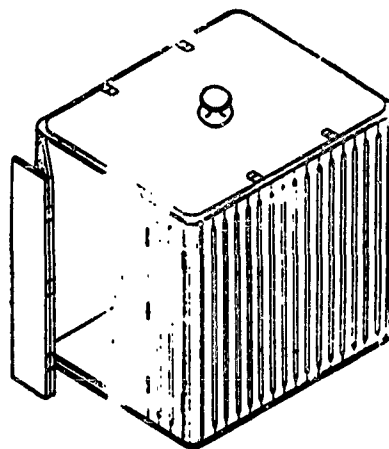

Fig. 1. 5-ton all-metal container

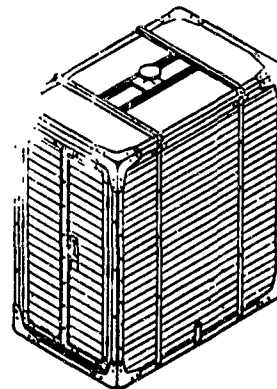

Fig. 3. 2.5-ton wooden container

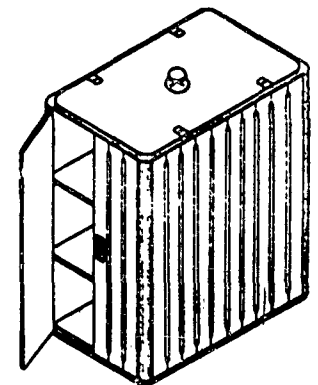

Fig. 2. 2.5-ton all-metal container

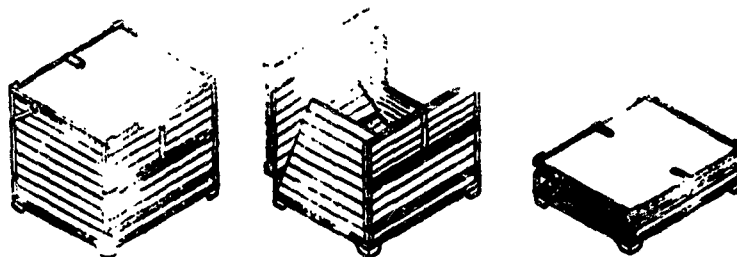

Fig. 4. Type I collapsible wooden container mounted on legs

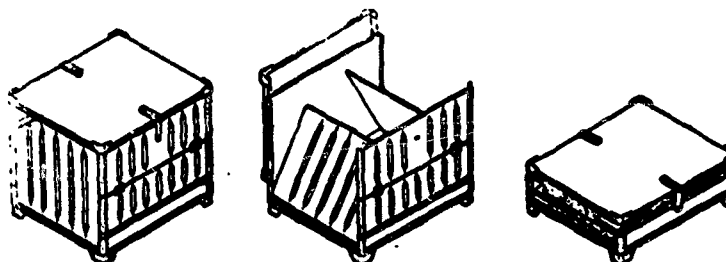

Fig. 5. Type I collapsible all-metal container mounted on legs

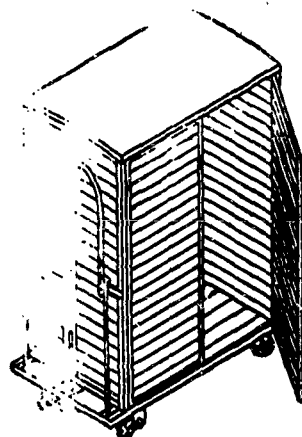

Fig. 6. Type II and III all-metal containers mounted on wheeled dolly

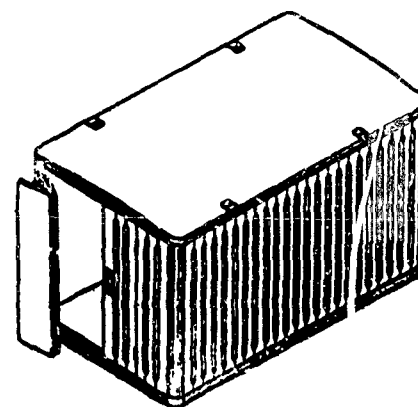

Fig. 7. 10-ton all-metal weather-proof container for shipment of autos

Specification (parameters)	Container types				
	Small containers for transport in covered wagons			For open platform transport	
	Type I (mounted on legs for two-tier loading)	Type II (mounted on wheels for single-tier loading)	Type III (mounted on wheels for single-tier loading)	Small units	Large units
Gross load capacity [kg]	550	800	1050	1250	10,000
Net load capacity [kg]	430	600	800	1000	8500
Weight of container [kg]	120	200	250	250	1500
Dimensions [mm]					
Length	1200	1400	1250	1325	4260
Width	800	820	1150	1050	2460
Height	2150	2050	2050	2300	2500
Loading space [m]	1.1	1.8	2.3	2.8	23

Frank, G. M. Container for storage and transport of radioactive materials (Author's certificate no. 120295). Byulleten' izobreteniy, no. 11, 1959, 31-32.

The container, which may be spherical or cylindrical in shape, is double-walled, with an inner wall of lead and an outer wall of cast iron. The purpose of such a design is to economize in the use of lead without greatly increasing the weight of the container.

Makurin, P. I. *Ekspluatatsiya gazovykh ballonov*  
(Employment of gas cylinders). Moskva, Mashgiz,  
1962. 210 p.

This booklet presents safety and fire protection require-  
ment data for storing, transporting, and using gas cylinders. The  
figure shown illustrates a discussion of the various sizes of gas  
cylinders, and is accompanied by the following comment in the text.  
"There also exist cylinders of larger dimensions. These are mounted  
on transporter frames and may be moved on railroad flatcars, trucks,  
and trailers."

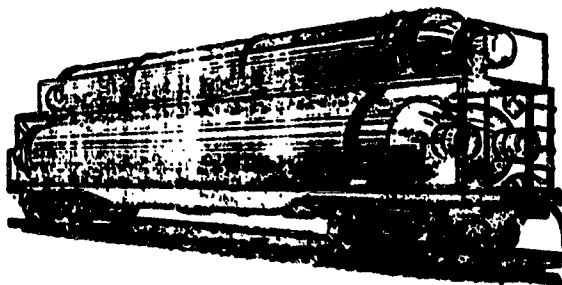

Battery of cylinders for transporting gas under high pressures

Ostrowski, Jan. Protection of railroad tank  
cars against corrosion. *Wiadomości naftowe*,  
no. 12, 1961, 282-294.

During the 1954-55 period, Polish industry used tank cars  
having bonderized interiors as protection against corrosion. Since  
bonderization (phosphate-chrome coating) lasts only 2-3 years, the  
industry began work on a new anticorrosion medium and succeeded in  
developing an epoxy polyamid varnish. The interior of an experi-  
mental tank car built in 1960 was coated with this varnish as  
follows: the tank's interior surfaces were sand blasted and the  
clean surface thus obtained was then coated with four layers of  
varnish. The second and fourth layers were applied at 2- to 3-day  
intervals. Aluminum powder was added to the varnish as pigment.  
The varnish was dried by infrared. The thickness of the coating  
thus obtained was 0.14 mm. The experimental tank car was used  
to transport various types of oils and lubricants over a 9-month  
period. The results confirmed the suitability and stability of  
epoxy polyamid varnish, which protected the surfaces from corrosion  
and assured the absolute purity of the transported product. Simulta-  
neously with the development of the epoxy polyamid varnish, the  
industry began experiments with an oil-resistant (stable) varnish  
based on styrol and acrylic acid. Tests are also being made with  
a bitumen-asphalt paste containing asbestos powder and aluminum  
(MA<sub>2</sub>) for protecting the external surfaces of tank cars against  
corrosion. The frames and carriages of tank cars were covered  
with 2 layers of this paste. After 6 days of drying, a dark  
silver-gray layer 0.5-mm thick was obtained. Its surface, though  
somewhat rough, was sufficiently smooth to meet painting speci-  
fications.

## BIBLIOGRAPHY

- 1) Akhmet'yev, L. N., and K. Ye. Nikul'shin. New heavy-duty trailer. Stroitel'nyye i dorozhnyye mashiny, no. 10, 1962, 9-10. TE223.885
- 2) Astakhov, A. I. Reliable machines for construction projects in the North and in Siberia. Stroitel'nyye i dorozhnyye mashiny, no. 3, 1962, 9-12. TE223.885
- 3) Blokhin, L. G., and A. V. Gorozhankin. New ДБК -50 crane. Stroitel'nyye i dorozhnyye mashiny, no. 10, 1962, 1-3. TE223.885
- 4) Bodnar, V. V. 220-kv power transformers for the Bratsk hydroelectric power station. Vestnik electropromyshlennosti, no. 7, 1962, 6-8. TK4.V396
- 5) Bol'shunov, F. F., and Ye. M. Sidorov. Machine for mechanization of installation operations in the electrification of railroads. Transportnoye stroitel'stvo, no. 9, 1962, 18-21. TF4.T67
- 6) Firsov, S. I. New freight containers for railroads. Byulleten' tekhniko-ekonomicheskoy informatsii, no. 9, 1960, 66-68. TS1.B5
- 7) Frank, G. M. Container for storage and transport of radioactive materials (Author's certificate no. 120295). Byulleten' izobreteniy, no. 11, 1959, 31-32. T285.A32
- 8) Giant cranes. Izvestiya, 5 Oct 1962, 3.
- 9) Langner, Karol. Model 606-Z 16-axle transporter for outsize loads. Przegląd kolejowy mechaniczny, v. 14, no. 2, 1962, 49-52. TF340.PT3
- 10) Makurin, P. I. Eksploatatsiya gazovykh ballonov (Employment of gas cylinders). Moskva, Mashgiz, 1962. 21 p.
- 11) Muzhichkov, N. I. Construction of a crane shop. Promyshlennoye stroitel'stvo, no. 6, 1962, 8-10. TH4.885
- 12) Ostrowski, Jan. Protection of railroad tankcars against corrosion. Wiadomości naftowe, no. 7, 1959, 51-57. HE7.Z5

- 13) Pozhitkov, V. I. Transport of outside equipment by water. Montazhnyye i spetsializirovannyye raboty v stroitel'stve, no. 11, 1962, 16-20.
- 14) Sitnik, M. D. Growth of container shipping and the choice of container types. Zheleznodorozhnyy transport, no. 7, 1959, 51-57.  
HE7.Z5