

UNCLASSIFIED

AD 401 791L

*Reproduced
by the*

**ARMED SERVICES TECHNICAL INFORMATION AGENCY
ARLINGTON HALL STATION
ARLINGTON 12, VIRGINIA**



UNCLASSIFIED

NOTICE: When government or other drawings, specifications or other data are used for any purpose other than in connection with a definitely related government procurement operation, the U. S. Government thereby incurs no responsibility, nor any obligation whatsoever; and the fact that the Government may have formulated, furnished, or in any way supplied the said drawings, specifications, or other data is not to be regarded by implication or otherwise as in any manner licensing the holder or any other person or corporation, or conveying any rights or permission to manufacture, use or sell any patented invention that may in any way be related thereto.

7
4017911Z

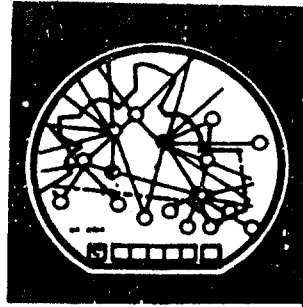

FINAL REPORT

Project No. 111-6V

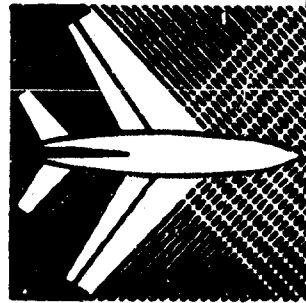

EVALUATION OF
M^CELROY TYPE MC-ARR-3
AUDIO RING RADIATOR

THIS REPORT APPROVED FOR FAA AND
GOVERNMENT DISTRIBUTION ONLY

DECEMBER 1962

ASTIA
APR 24 1963



FEDERAL AVIATION AGENCY
Systems Research & Development Service

EVALUATION DIVISION

Atlantic City, New Jersey

FINAL REPORT
EVALUATION OF
McELROY TYPE MC-ARR-3 AUDIO RING RADIATOR

PROJECT NO. 111-6V

Prepared by:

L. E. Danes

L. E. Danes
Project Manager

E. Lind

E. Lind
Project Engineer

Reviewed by:

L. E. Danes

L. E. Danes
Chief, Communications Section

Joseph A. Fantoni

Joseph A. Fantoni
Chief, Data Acquisition Branch

This report is hereby approved for publication and submission to the Director, Systems Research and Development Service. The material contained herein and the conclusions and recommendations are based upon the performance of the assigned project by the Evaluation Division and were in no way directed from sources external to this Division.

Alfred Lingard
Chief, Evaluation Division

December 1962

FEDERAL AVIATION AGENCY
Systems Research and Development Service
Evaluation Division
National Aviation Facilities Experimental Center
Atlantic City, New Jersey

TABLE OF CONTENTS

	Page
ABSTRACT	iii
INTRODUCTION	1
Purpose	1
Background	1
DISCUSSION	2
Description of Equipment	2
Test Procedures and Results.	2
General.	2
Frequency Response Measurements.	5
Radiation Pattern Measurements	5
Operational Tests	13
Summary of Results	19
CONCLUSIONS	20
RECOMMENDATIONS	20
APPENDIX I	
Controller Questionnaires (4 Pages)	
APPENDIX II	
Simulator Operational Test Script (1 Page)	

LIST OF ILLUSTRATIONS

Figure		Page
1	McElroy Audio Ring Radiator, Type MC-ARR-3	3
2	Component Parts of McElroy Audio Ring Radiator Type MC-ARR-3	4
3	Frequency Response Curve of the MC-ARR-3 and Measurement Test Equipment Setup, Block Diagram	6
4	Sound Radiation Level Pattern Data of a Single MC-ARR-3 Speaker (At 1000 cps)	8
5	Radiation Pattern Measurement Test Equipment Setup	9
6	Radiation Pattern Radial Plots at 500, 1000, and 3000 cps Along 0° Radial.	10
7	Radiation Pattern Radial Plot at 1000 cps	11
8	Arrangement of Type MC-ARR-3 Speakers Over A-4 Flight Progress Boards	12
9	Radiation Pattern Plots at 1000 cps and 4-foot Vertical Separation	14
10	Radiation Pattern Plots at 1000 cps and 5-foot Vertical Separation	15
11	Radiation Pattern Plots at 1000 cps and 6-foot Vertical Separation	16
12	MC-ARR-3 Speaker Installation at a Radar Controller Position	18

Evaluation Division, Systems Research and Development Service,
Federal Aviation Agency, Atlantic City, N. J.
EVALUATION OF McELROY AUDIO RING RADIATOR MC-ARR-3
by E. Lind and L. E. Danes, December 1962
8 pp., plus 12 illus., plus 2 Appendices, 5 pages, Final Report
(Project No. 111-6V)

ABSTRACT

This report discusses the evaluation tests conducted at the National Aviation Facilities Experimental Center (NAFEC), Atlantic City, New Jersey, on six Type MC-ARR-3 McElroy Ring Radiators, developed by the McElroy Electronics Corporation, Littleton, Massachusetts.

The MC-ARR-3 is a directional loudspeaker consisting of a conical horn, diffuser, and a University Loudspeaker Co. Model MA-25 driver unit. The diffuser design and placement within the horn is such that the system terminates as a ring radiator.

Tests included measurement of the loudspeaker frequency response and radiation pattern. A determination was also made of the acoustic interference level between controller positions when the MC-ARR-3 speakers were installed and operated in close proximity as required in an Air Traffic Control Facility. In addition, the operational performance of the MC-ARR-3 was subjectively compared to the Western Electric Type 106-A and Jensen Mfg. Co. Type AP-10 speakers.

A description of the McElroy Ring Radiators, the principle of operation, and the test procedures applied during the evaluation are included. It was concluded that use of the MC-ARR-3 did not significantly reduce the audio interference level between adjacent controller positions and it is recommended that this loudspeaker not be adopted for Air Traffic Control Facility use.

INTRODUCTION

Purpose

The purpose of Project No. 111-6V was to evaluate the McElroy Audio Ring Radiator, Type MC-ARR-3, designed by McElroy Electronics Corporation, Littleton, Massachusetts, to determine its general performance characteristics and the audio interference level between adjacent controller positions in an Air Traffic Control Facility when these loudspeakers are utilized.

Background

Present Air Traffic Control facilities house a large number of operating positions in close proximity. Since each position is equipped with one or more loudspeakers, the level of acoustic interference is comparatively high, resulting in lower intelligibility and operator fatigue.

A considered method of reducing the interference is by the use of directional loudspeakers that confine the sound to the immediate vicinity of the operator concerned and minimize radiation into adjacent areas. The coverage pattern of the Western Electric Type 106-A loudspeaker which is presently in general use at Air Traffic Control facilities, as well as others being used, is such that radiation into adjacent controller areas occurs causing audio interference. These speakers are generally panel mounted at each operator position.

The Type MC-ARR-3 loudspeaker, developed by the McElroy Electronics Corporation, Littleton, Massachusetts, was intended by the manufacturer for use in multiple channel audio systems to reduce the crosstalk and interference between adjacent listener positions.

The Federal Aviation Agency purchased six (6) identical prototype models for evaluation to determine if this speaker offers any advantages over existing interphone and radio loudspeakers.

The six Type MC-ARR-3 loudspeakers were submitted to operational test in a simulated and a live Air Traffic Control environment at the National Aviation Facilities Experimental Center (NAFEC), to determine whether or not installation of these loudspeakers at adjacent controller positions decreases existing audio interference. In addition, frequency response and radiation pattern tests were performed on the MC-ARR-3 loudspeakers.

DISCUSSION

Description of Equipment

The McElroy Audio Ring Radiator, Type MC-ARR-3 as shown in Figure 1, was designed to give a highly directional pattern with efficient audio response. Directivity is achieved by inserting a correcting diffuser into a conical horn, thus transforming the horn from a conic section into an exponential one. The diffuser is placed in such a position that the system terminates in a ring radiator. The component parts of the reproducer are shown in Figure 2. The driver unit is a standard University Loudspeaker Company Model MA-25 which has a power rating of 25 watts. The horn and cone which is used as a diffuser are fabricated of spun aluminum.

The manufacturer's specifications for the MC-ARR-3 loudspeaker are as follows:

1. Frequency Response: uniform from 300 to 4000 cps.
2. Focal Distance: approximately 5 feet.
3. Power Rating: 25 watts (using the University MA-25 driver unit).
4. Dimensions: 20.5 inches long with a maximum horn diameter of 12 inches.
5. Weight: 4.25 pounds (without the driver unit).
6. Focal Area: 3 feet diameter at 5 foot distance from mouth of loudspeaker; nominally 3 db down at 4 foot diameter.

Test Procedures and Results

1. General

Evaluation of the MC-ARR-3 loudspeaker included a determination of the frequency response and acoustical radiating characteristics and the effect of employment of this speaker in an operational Air Traffic Control complex. In addition, the positioning of the speakers with respect to height above operating personnel was experimented with.

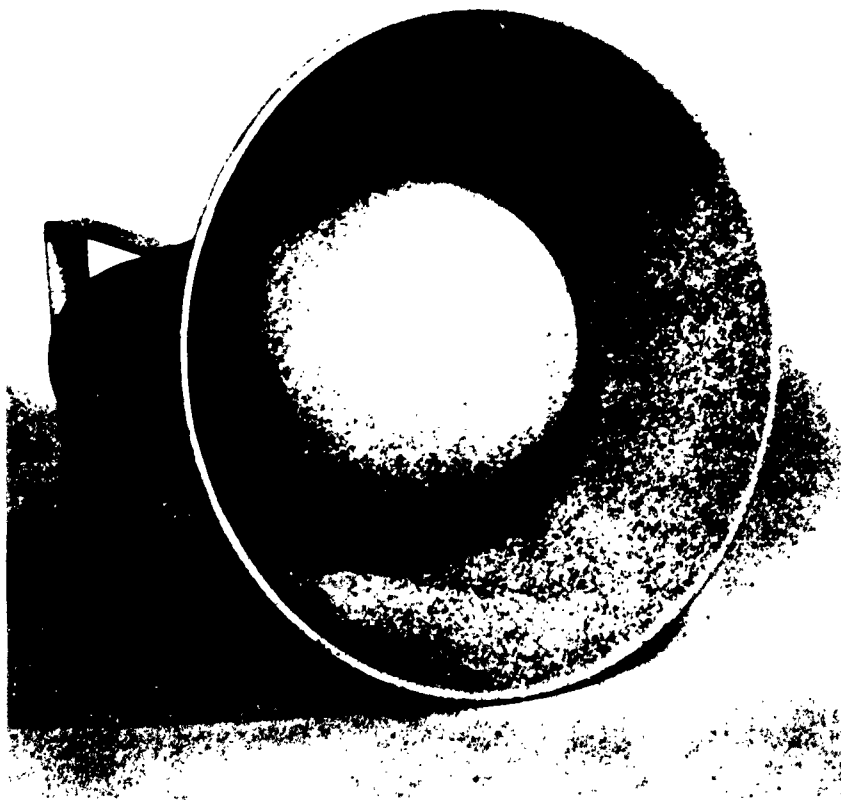

FIG. 1 MC ELROY AUDIO RING RADIATOR, TYPE MC-ARR-3
(BOTTOM VIEW)



FIG. 2 COMPONENT PARTS OF MC ELROY AUDIO RING RADIATOR,
TYPE MC-ARR-3

2. Frequency Response Measurement:

The frequency response characteristic data obtained and the test arrangement used is shown in Figure 3. The output of a General Radio Beat Frequency Audio Oscillator, Type 1304-B, was amplified by a Stromberg-Carlson amplifier, Model ASR-433, and used to excite the MC-ARR-3. The output of the Beat Frequency Audio Oscillator was checked and found to be constant over the audio frequency spectrum of 250 cps to 20 kc. The frequency response characteristic of the Stromberg-Carlson audio amplifier was also checked and found to be .5 db down at 300 cps and at 20 kc with respect to the level at 1000 cps.

In conducting the frequency response measurement, the MC-ARR-3 loudspeaker was located ten feet above and parallel to the floor in a large room so that it radiated towards a wall draped with several layers of sound absorbing material. The loudspeaker was approximately ten feet away from the sound absorbing material and the General Radio Sound Level Meter, Model 1551-B, was located four feet in front of the loudspeaker and slightly below its longitudinal axis. The output of the sound level meter was fed to the General Radio Graphic Level Recorder, Type 1521-A.

Loudspeaker response was checked between 120 and 9000 cps., using the mean level at 1000 cps as a reference. The frequency response characteristic obtained, shown in Figure 3, indicates that the speaker response is within minus 12 db and plus 6 db of the reference level between 400 and 4000 cps.

Since an anechoic room was not available at NAFEC for use in conducting this test, various distances between the loudspeaker and sound absorbing material and between the loudspeaker and the sound level meter were used in an effort to determine whether reflections were affecting the measurement. All data curves so obtained were similar to that shown in Figure 3 thus indicating that reflections were not significant.

3. Radiation Pattern Measurements:

One MC-ARR-3 speaker was subjected to test to determine its directional characteristics when operated in an area relatively free of reflections. The radiation characteristics of the remaining five speakers were also determined while positioned over the A-4 Flight Progress Boards.

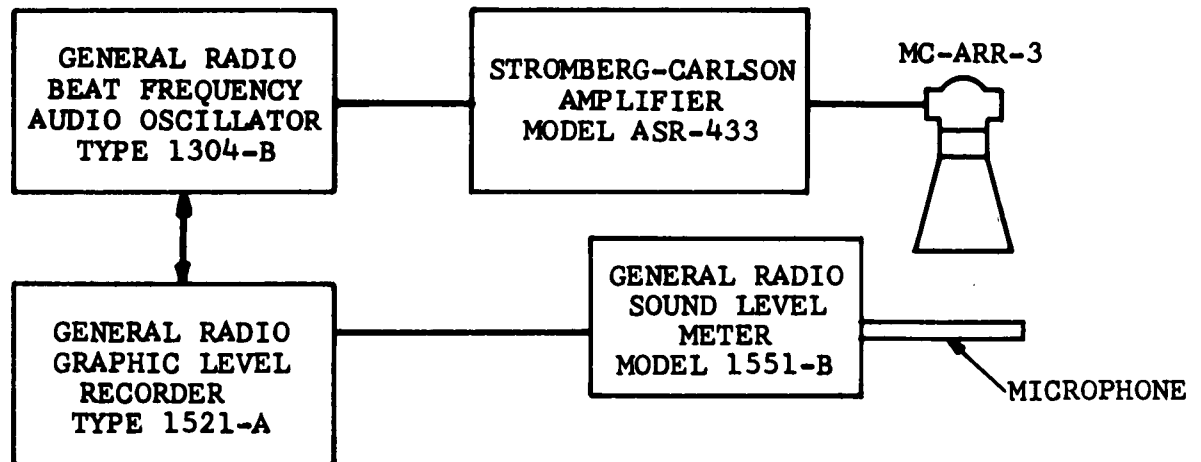
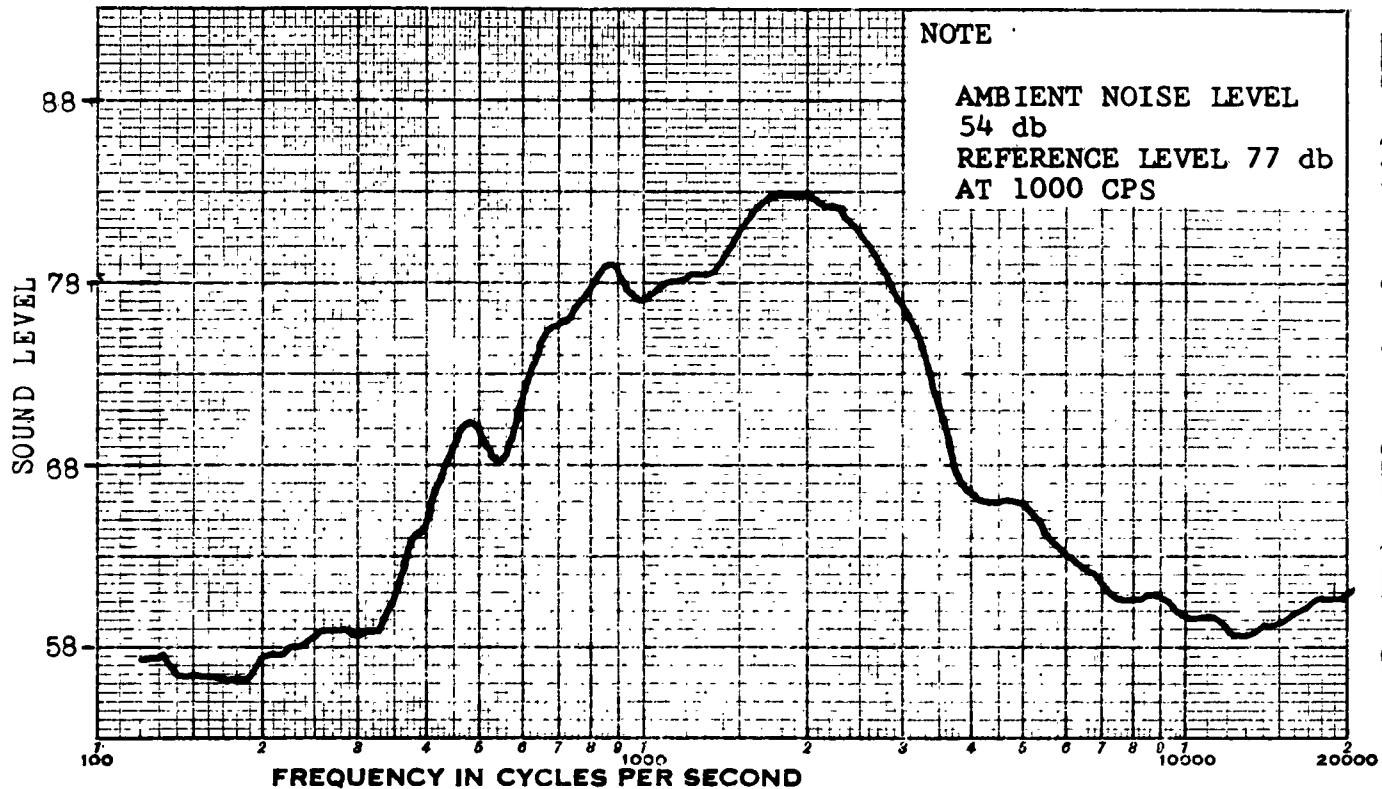

FIG. 3 FREQUENCY RESPONSE CURVE OF THE MC-ARR-3 AND MEASUREMENT TEST EQUIPMENT SETUP, BLOCK DIAGRAM

Figure 4 presents the data obtained during measurement of the radiation circularity of the single speaker. Although this measurement was not carried out under ideal free field conditions (use of an anechoic room, etc.), care was taken in the selection of the site, etc., to minimize the effect of reflections.

Sound level measurements were made at one foot increments along each radial to a distance of eight feet from the focal point of the speaker using the test setup shown in Figure 5. The speaker was positioned at a height of five feet above the Sound Level Meter microphone. During this test the ambient noise level was 52 db, the signal frequency was 1000 cycles per second, and the signal level was 38 db above the ambient noise level (reference level as measured at the focal point of the speaker). The results of this test, shown in Figure 4, indicate that the sound level radiation can be considered to be equal at all points equally distant from the longitudinal axis of the speaker.

Using the same test procedures and conditions, measurement of the sound radiation along the 0° radial was also performed at frequencies of 500, 1000, and 3000 cps. The test results are shown in Figure 6.

As a further test toward verifying the directivity of the radiation pattern, sound level measurements were made outdoors in a cleared area with the loudspeaker suspended ten feet above ground and pointing vertically downward between two towers 80 feet apart. The General Radio Sound Level Meter, Model 1551-B, was located five feet below the loudspeaker and the audio signal level was measured along a straight line from the longitudinal axis of the loudspeaker to a point 65 feet away. Readings were taken at one foot increments between 0 and 15 feet, then at five foot increments between 15 and 65 feet. The reference level was 108 db directly under the loudspeaker. The ambient noise level was 66 db. Thus, signal level was 42 db above the ambient. This check was performed at a frequency of 1000 cps. The results of this test, shown in Figure 7, indicate that after an initial rise in level at the one and two foot points, signal level drops gradually to 78 db at the 65 foot point. This represents an over-all drop of 30 db from the reference level.

Following the installation of five MC-ARR-3 loudspeakers over the A-4 Flight Progress Board operator positions as shown in Figure 8, sound radiation measurements were performed. The tests were conducted at a frequency of 1000 cycles per second using speaker heights of 8, 9, and 10 feet above the floor. With the microphone remaining at 4 feet above the floor, these heights corresponded to speaker - microphone vertical separations of 4, 5, and 6 feet respectively.

NOTES: AMBIENT NOISE LEVEL 52 db REFERENCE LEVEL
 SET TO 90 db WITH MICROPHONE LOCATED 5 FEET
 BELOW SPEAKER AND 1 FOOT ALONG 0° RADIAL

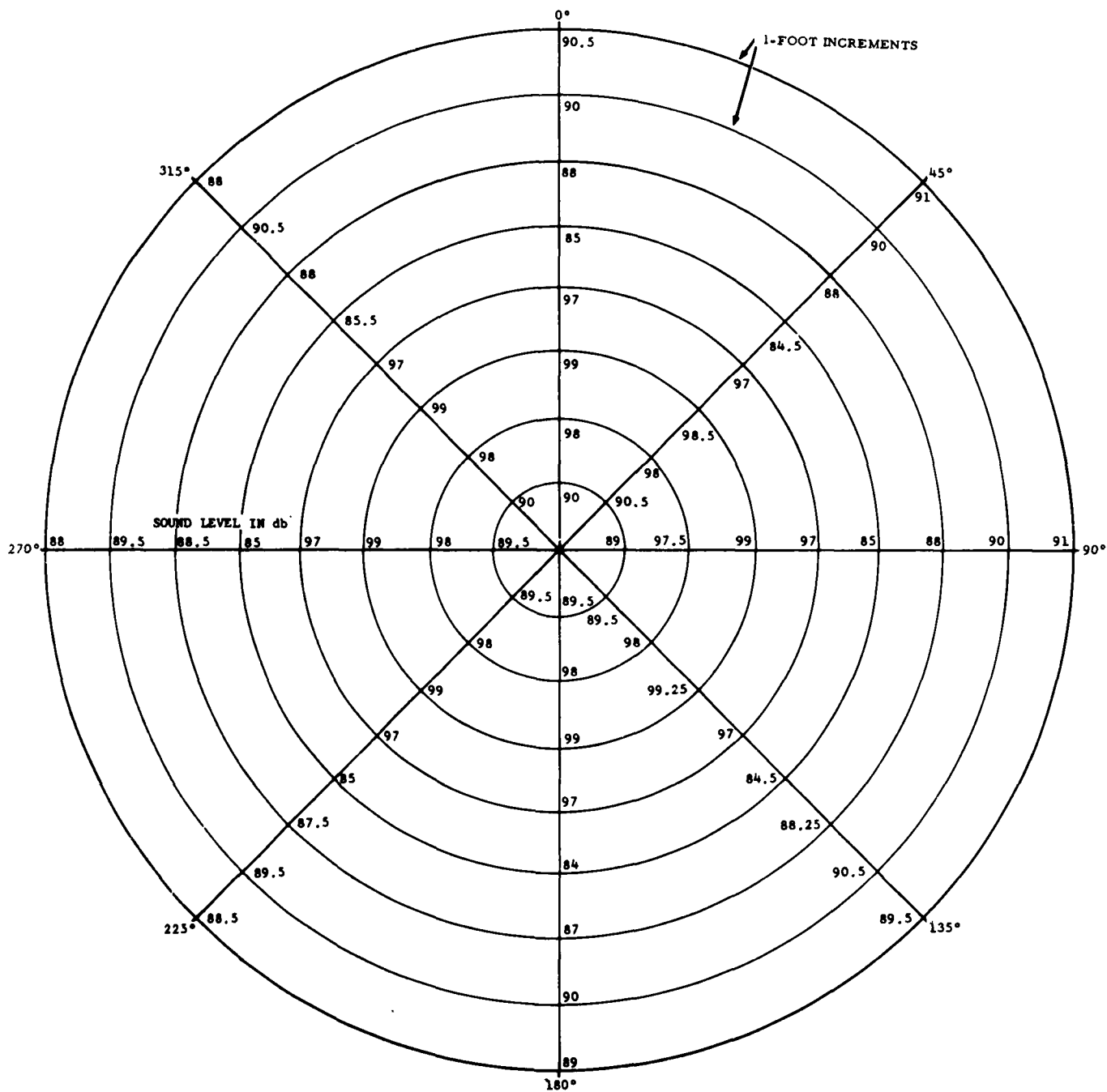

FIG. 4 SOUND RADIATION LEVEL PATTERN DATA OF A SINGLE MC-ARR-3 SPEAKER (AT 1000 CPS)

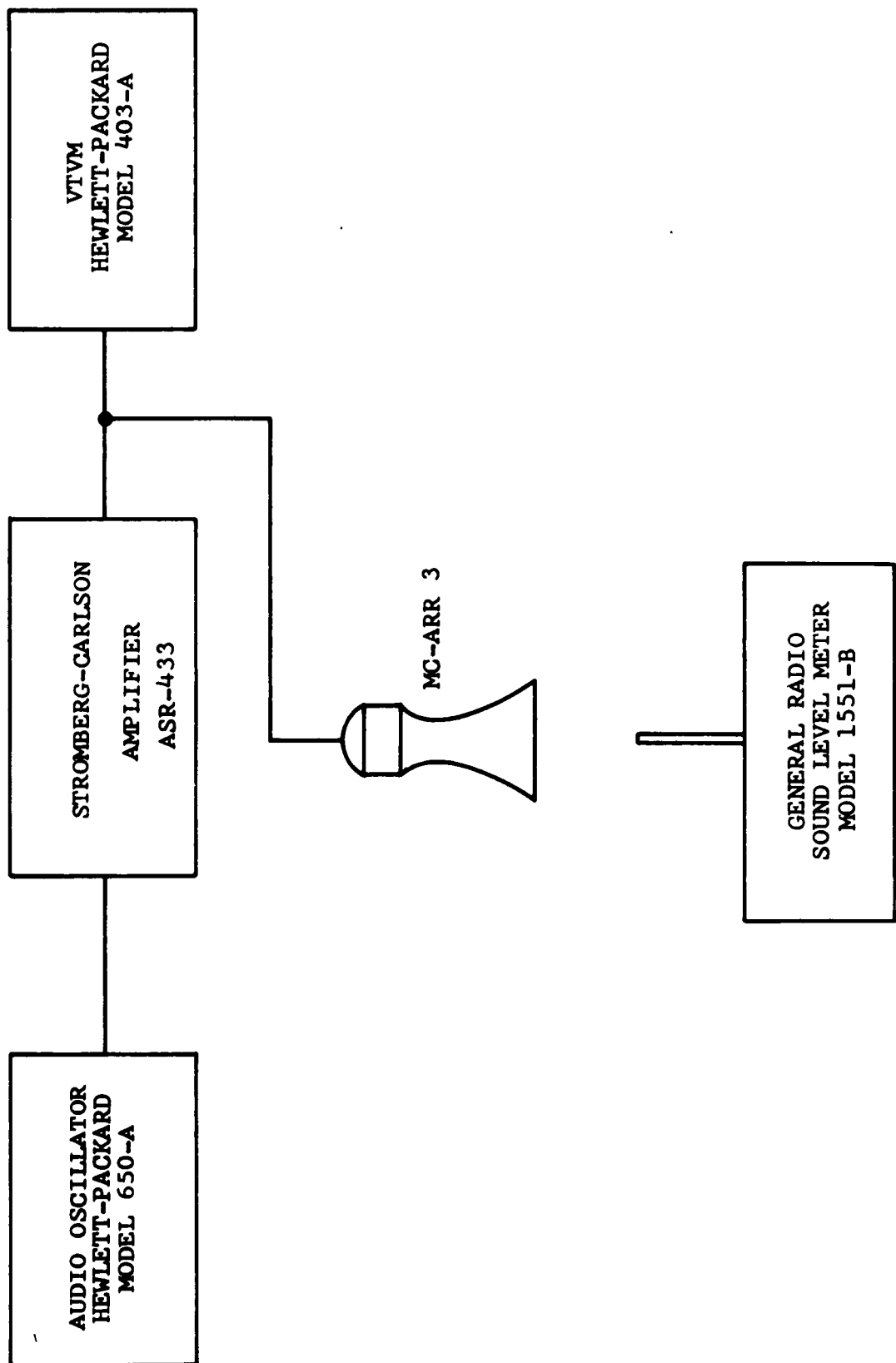
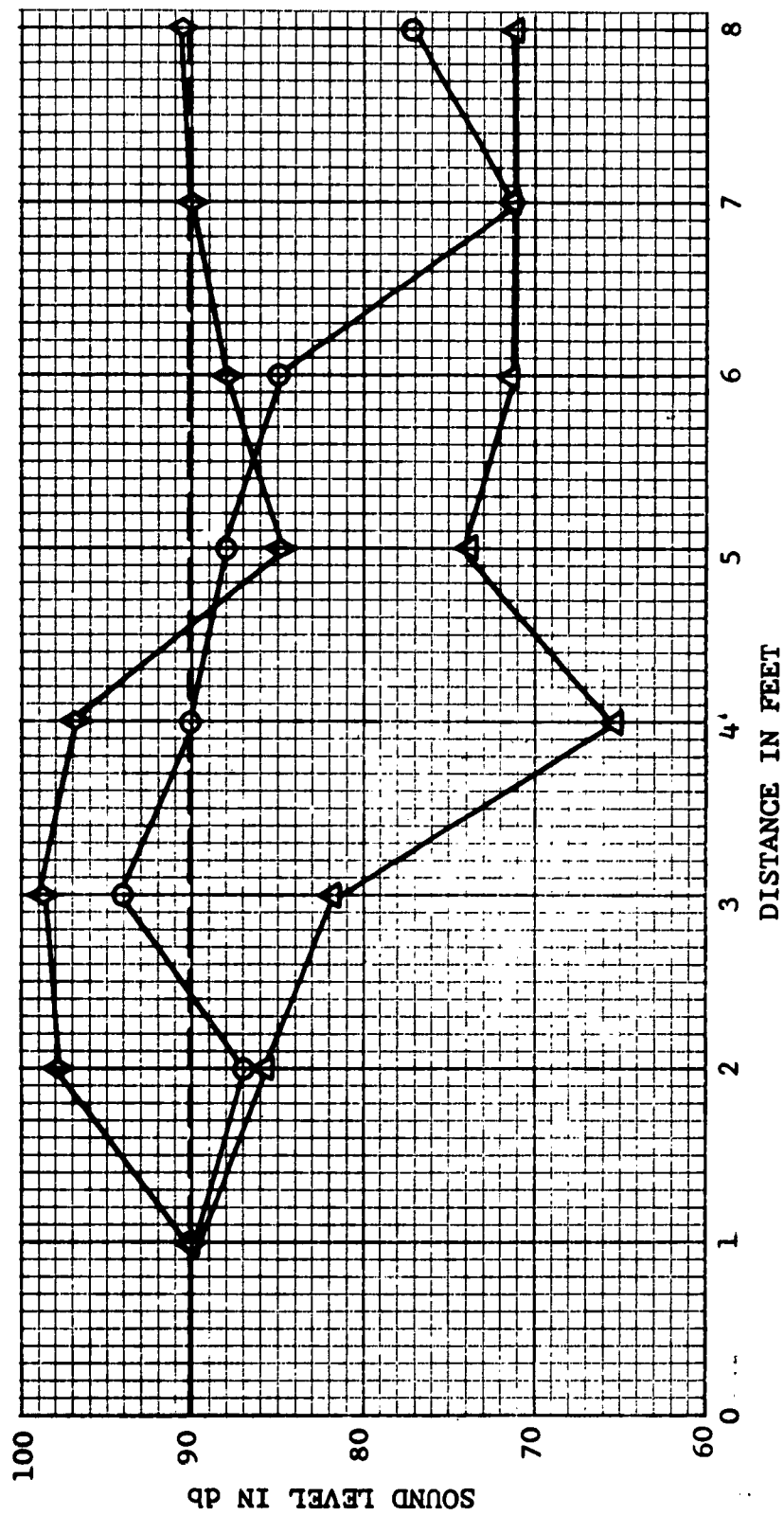

FIG. 5 RADIATION PATTERN MEASUREMENT TEST EQUIPMENT SETUP



NOTES:

- AMBIENT NOISE 52 db
- REF. LEVEL 90 db
- 5 FEET BELOW SPEAKER

LEGEND

- ◇ 1000 CPS
- 500 CPS
- △ 3000 CPS

FIG. 6 RADIATION PATTERN RADIAL PLOTS AT 500, 1000, AND 3000 CPS ALONG 0° RADIAL

NOTES

AMBIENT NOISE LEVEL 66 db
REFERENCE LEVEL 108 db
5 FEET BELOW SPEAKER

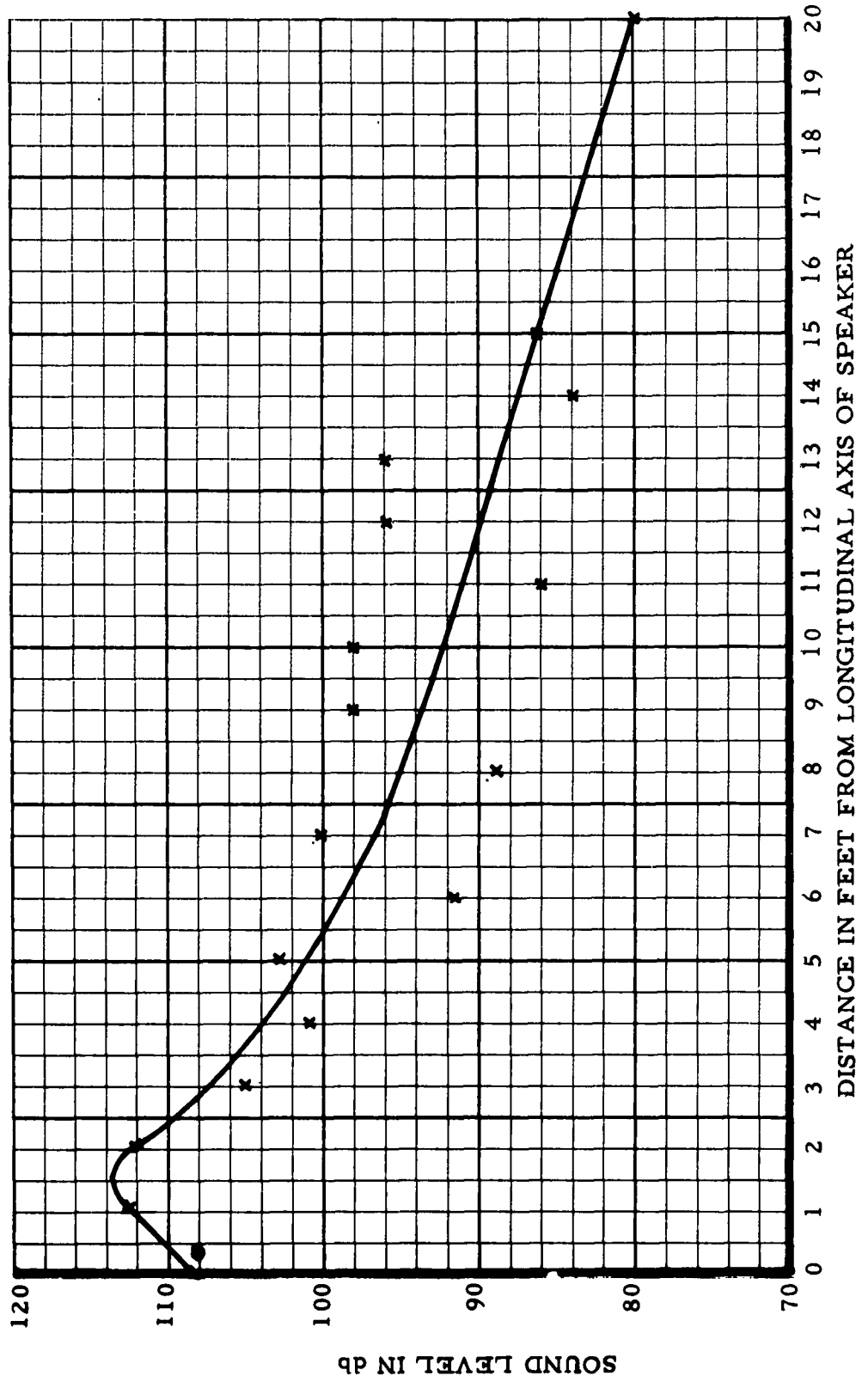

FIG. 7 RADIATION PATTERN RADIAL PLOT AT 1000 CPS

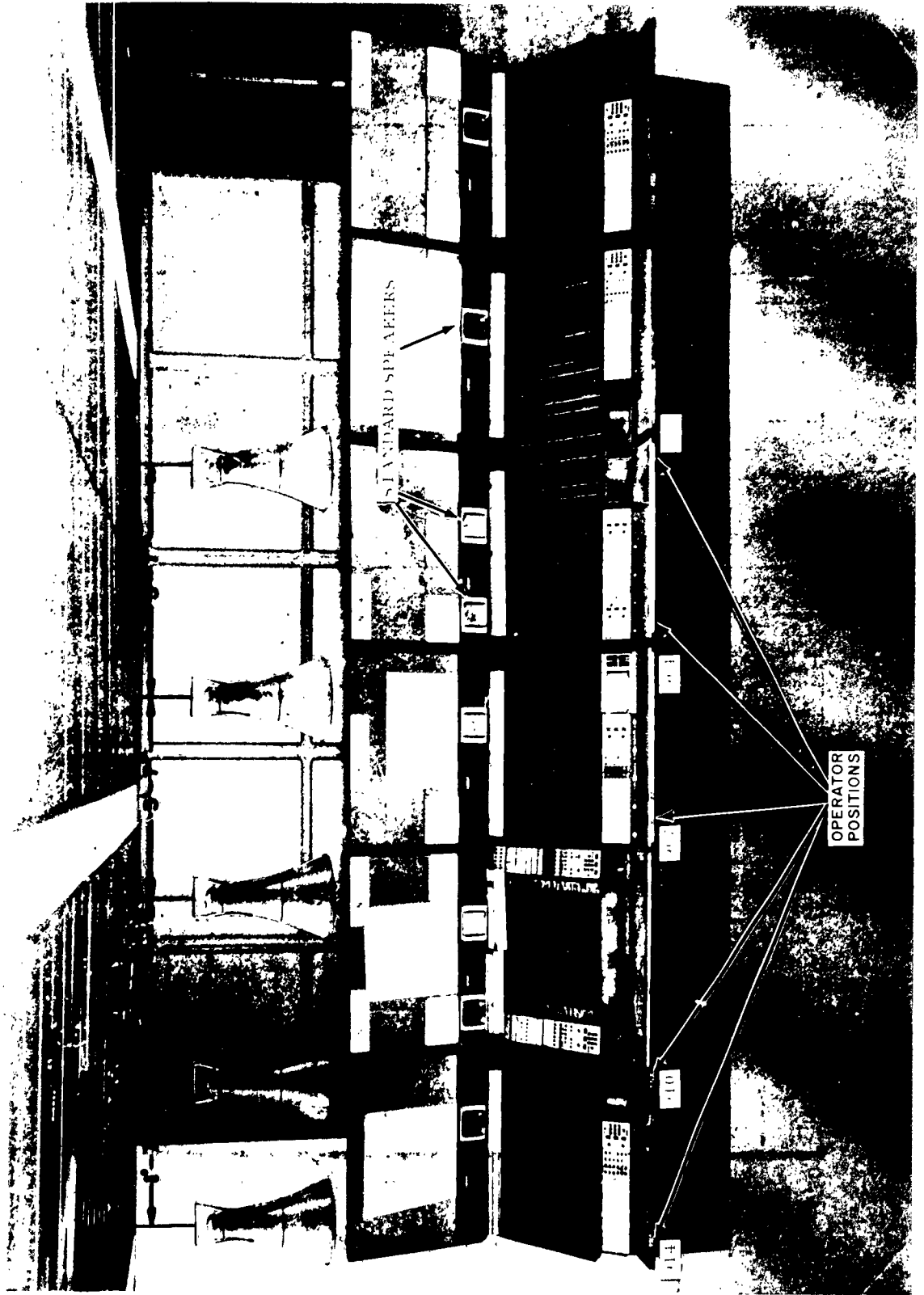

FIG. 8 ARRANGEMENT OF TYPE MC-ARR-3 SPEAKERS
OVER A-4 FLIGHT PROGRESS BOARDS

Sound level readings were taken using the setup shown in Figure 5. Because of surrounding equipment, sound level measurements were made in only two diametrically opposite directions parallel to the A-4 Flight Progress Boards. Results obtained from the speakers over positions 903, 907, 910, and 914 are presented in Figures 9, 10, and 11. These results indicate that the sound radiation pattern is considerably modified by the reflections from the A-4 consoles, floor, walls, etc. In addition, at distances off speaker center which correspond to adjacent controller positions (at 3'7" and 1'7" separations), the sound level is comparable to that obtained at the speaker center line. A pattern change also occurs as the vertical height of the speaker is varied.

4. Operational Tests:

Operational tests were carried out in two parts. The first part involved ten Air Traffic Control (ATC) operators operating in the simulated ATC Center environment at NAFEC (Simulator A Laboratory). During this test the speakers were also positioned over the A-4 Flight Progress Boards (A-4 FPB) as shown in Figure 8. Operators were positioned at the A-4 Board locations as they would normally be in an actual operational facility. Provision was made for selecting either the Bell Telephone No. 300 Switching System speaker (Western Electric Type 106-A) or the MC-ARR-3. The controller thus could compare the performance of each speaker.

For a portion of this test, operators at other simulator positions (other than the A-4 positions) using prepared scripts, communicated with the A-4 controller positions in a prescribed sequence. A sample of the script used is included in Appendix II. The communication sequences included simultaneous transmissions to various combinations of A-4 position speakers.

During the second portion of tests conducted in the simulated ATC environment (using the A-4 FPB), the controllers' positions were operated during the course of conducting another project and the performance of the MC-ARR-3 speakers was once again compared to the standard speaker. At the conclusion of these tests, the A-4 FPB controller personnel were asked to complete a questionnaire. Questionnaire No. 1 in Appendix I is a sample of the questionnaire used which, in addition, contains a tabulation of the data received from the controllers in response to each question.

The second part of the operational test took place in the NAFEC Experimental Flight Traffic Control Facility, under operational conditions, over a period of three weeks. Three MC-ARR-3 loudspeakers

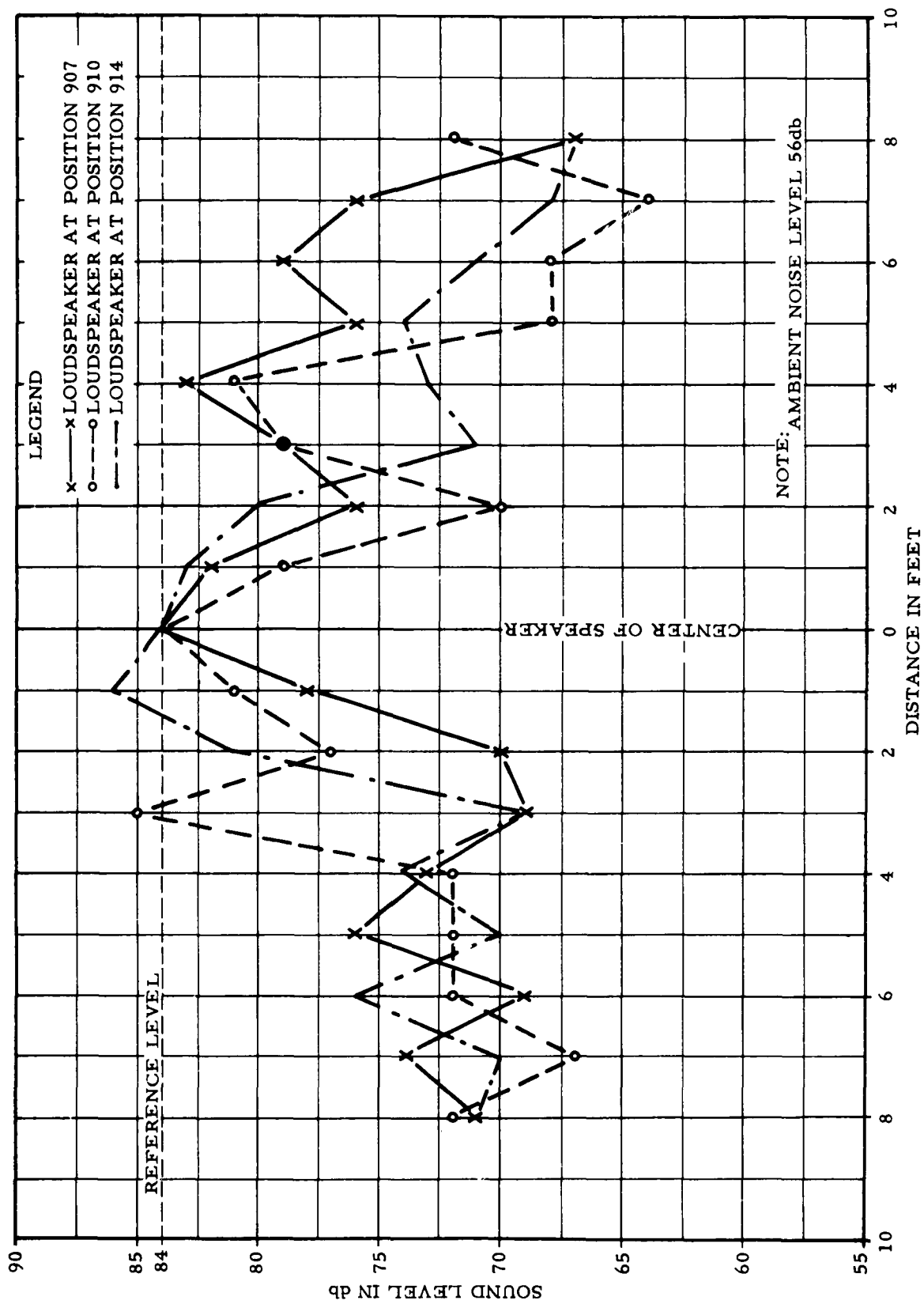

FIG. 9 RADIATION PATTERN PLOTS AT 1000 CPS AND 4-FOOT VERTICAL SEPARATION

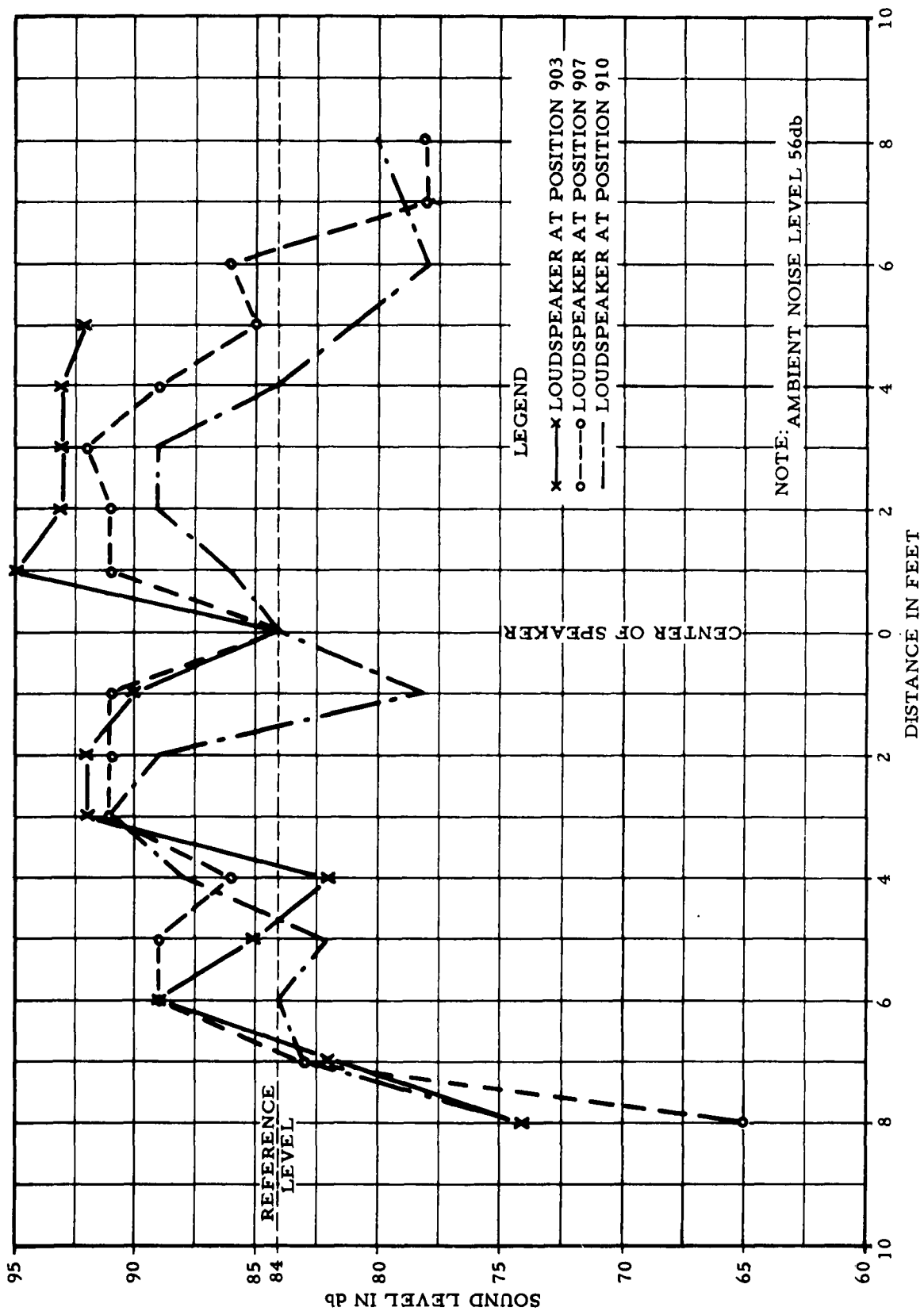

FIG. 10 RADIATION PATTERN PLOTS AT 1000 CPS AND 5-FOOT VERTICAL SEPARATION

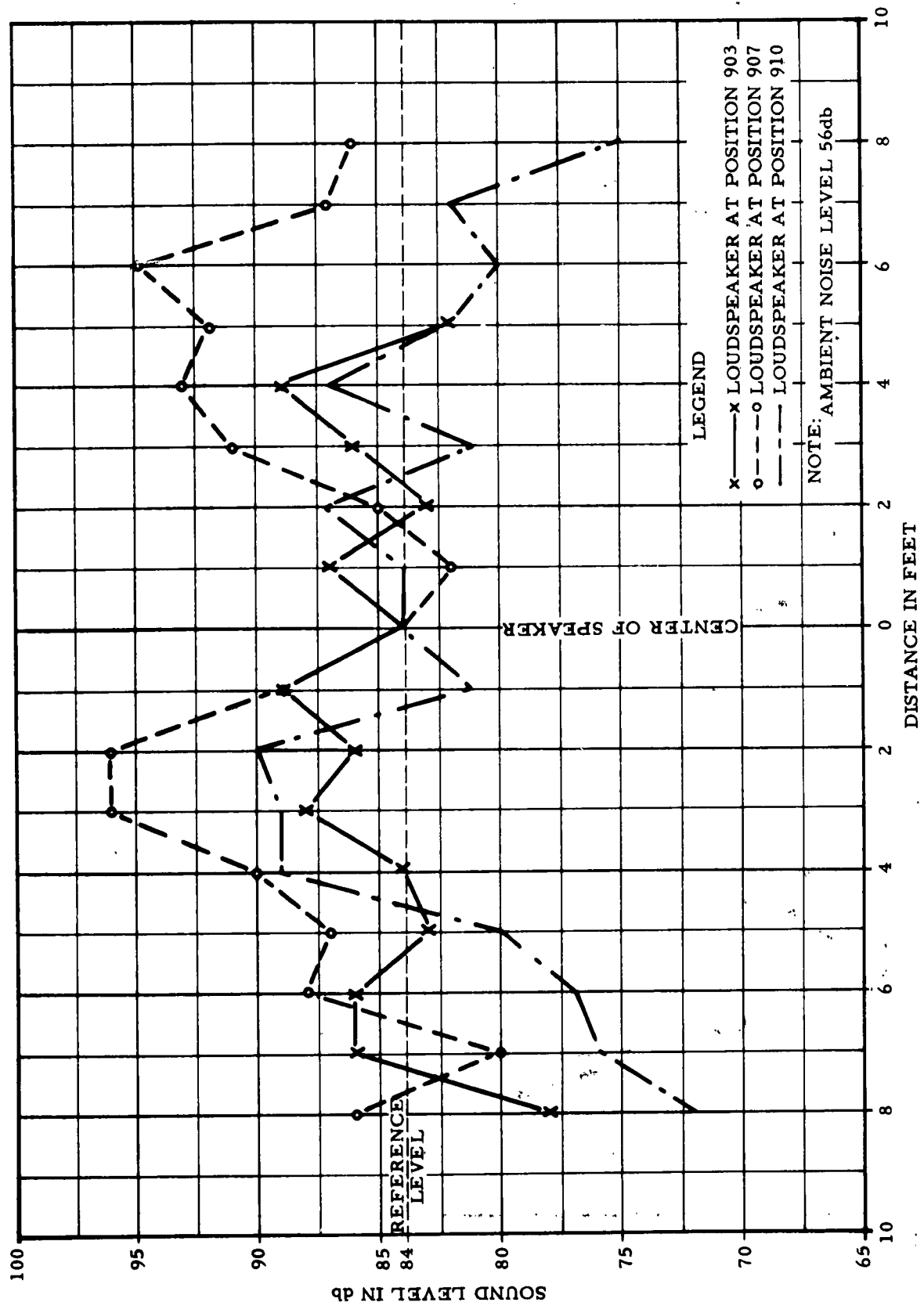

FIG. 11 RADIATION PATTERN PLOTS AT 1000 CPS AND 6-FOOT VERTICAL SEPARATION

were positioned at a height of six feet four inches (above floor) over each of three radar controller operating positions which were separated a distance of approximately five feet. Figure 12 shows a typical speaker installation at one operating position. During this test period the controller, at his discretion, could once again select the existing facility speaker (Jensen Mfg. Co. Type AP-10) or the overhead MC-ARR-3 speaker for a comparison of performance. Upon completion of this three-week test period, each participating controller completed a questionnaire. The sample questionnaire used is shown in Appendix I (Questionnaire No. 2). There is also contained a tabulation of the data received from the controllers in response to each question.

Analysis of the completed questionnaires (No. 1 and No. 2) indicates the following:

- a. The output sound quality of the MC-ARR-3 was, in general, considered to be better than the Western Electric Type 106-A and the Jensen Type AP-10 speakers.
- b. Positioning the speakers eight feet above the floor provided the best performance.
- c. There continued to exist appreciable adjacent position sound interference when using the MC-ARR-3 speakers. However, the interference level was considered by a majority to be less than that when using the standard speakers.
- d. A majority (11 to 1) expressed a preference for the MC-ARR-3 speaker.



FIG. 12 MC-ARR-3 SPEAKER INSTALLATION AT A
RADAR CONTROLLER POSITION

Summary of Results

1. The MC-ARR-3 speaker frequency response is within minus 12 db and plus 6 db of the reference level between 400 and 4000 cps.

2. The MC-ARR-3 sound level radiation is approximately circular (equal at all points equally distant from the longitudinal axis of the speaker).

3. The directivity of the MC-ARR-3 radiation pattern is such that a 3 db decrease in level at a radial distance of two feet as specified by the manufacturer is not provided. Measurement data indicates that after an initial rise in level at the one and two foot distances, the signal level decreases gradually to 78 db at a distance of 65 feet, representing an over-all drop of 30 db from the reference level.

4. When the MC-ARR-3 is positioned over A-4 Flight Progress Boards the sound radiation pattern is modified by the reflections from the A-4 consoles, floor, walls, etc. At distances off speaker center which correspond to adjacent controller operating positions, the sound level is comparable to and in some instances greater than that obtained directly beneath the speaker.

5. Results of the operational tests conducted in a simulated and live ATC Center environment were as follows:

a. The output sound quality of the MC-ARR-3 was, in general, considered by the controllers to be better than the Western Electric Type 106-A and the Jensen Mfg. Co. Type AP-10.

b. Positioning the speakers at the four (4) foot height above the controller (eight feet above the floor) provided the best performance.

c. There continued to exist appreciable adjacent position sound interference when using the MC-ARR-3 speakers. However, the interference level was considered by a majority of the controllers to be less than that when using the standard speakers.

d. A majority of the controllers (11 to 1) expressed a preference for the MC-ARR-3 speaker.

CONCLUSIONS

Based upon the results of the MC-ARR-3 loudspeaker evaluation conducted under Project No. 111-6V, it is concluded that:

1. The audio interference level between adjacent controller positions in an Air Traffic Control Facility is not significantly reduced by the use of the MC-ARR-3 loudspeaker.
2. The output sound quality of the MC-ARR-3 is better than the Bell Telephone Co. No. 300 Switching System speakers (Western Electric Type 106-A) and the Jensen Mfg. Co. Type AP-10.

RECOMMENDATIONS

Based on the evaluation of the MC-ARR-3 loudspeaker as required by Project No. 111-6V, it is recommended that:

1. The McElroy Type MC-ARR-3 loudspeaker not be adopted for Air Traffic Control Facility use.
2. Development of other approaches for reducing the audio interference level between adjacent controller positions in an Air Traffic Control Facility be pursued.
3. The sound quality of standard speakers now in field use be evaluated and a determination made as to the requirements for improvements in sound reproduction and intelligibility.

APPENDIX I

CONTROLLER QUESTIONNAIRES

This Appendix presents a copy of the questionnaire forms used for securing controllers' opinions and judgment regarding their experiences in using the MC-ARR-3 loudspeakers. Questionnaire Form No. 1 was completed by the controllers on conclusion of tests in the simulated Air Traffic Control environment. Form No. 2 was completed following a test period under operational conditions in the NAFEC Experimental Flight Traffic Control Facility.

Included on these forms, following each question, is the tabulation of the controllers' responses.

CONTROLLER QUESTIONNAIRES

Questionnaire No. 1

1. As a controller, how would you evaluate the McElroy Speaker?

One (1) controller indicated - No better than present standard speakers.

Six (6) controllers indicated - Better than present standard speakers.

One (1) controller indicated - MC-ARR-3 is too directional.

Two (2) controllers indicated - No comment

2. Is there a discernable difference in the over-all quality of the McElroy Speaker when used with a standard 300 System Speaker?

Three (3) controllers indicated - No difference.

Six (6) controllers indicated - MC-ARR-3 is better.

One (1) controller indicated - No comment.

3. At what approximate height do you feel the McElroy Speaker functioned best?

Two (2) controllers indicated - 2 ft. above controller's head.

Eight (8) controllers indicated - 4 ft. above controller's head.

4. When two McElroy Speakers in close proximity to one another were in use, do you feel there was any appreciable interference?

Two (2) controllers indicated - Yes

Five (5) controllers indicated - No

Three (3) controllers indicated - Yes, less than standard speakers.

5. When all McElroy Speakers were active in unison, was there any appreciable interference?

Six (6) controllers indicated - Yes

CONTROLLER QUESTIONNAIRES

Questionnaire No. 1

1. As a controller, how would you evaluate the McElroy Speaker?
 - One (1) controller indicated - No better than present standard speakers.
 - Six (6) controllers indicated - Better than present standard speakers.
 - One (1) controller indicated - MC-ARR-3 is too directional.
 - Two (2) controllers indicated - No comment
2. Is there a discernable difference in the over-all quality of the McElroy Speaker when used with a standard 300 System Speaker?
 - Three (3) controllers indicated - No difference.
 - Six (6) controllers indicated - MC-ARR-3 is better.
 - One (1) controller indicated - No comment.
3. At what approximate height do you feel the McElroy Speaker functioned best?
 - Two (2) controllers indicated - 2 ft. above controller's head.
 - Eight (8) controllers indicated - 4 ft. above controller's head.
4. When two McElroy Speakers in close proximity to one another were in use, do you feel there was any appreciable interference?
 - Two (2) controllers indicated - Yes
 - Five (5) controllers indicated - No
 - Three (3) controllers indicated - Yes, less than standard speakers.
5. When all McElroy Speakers were active in unison, was there any appreciable interference?
 - Six (6) controllers indicated - Yes

Three (3) controllers indicated - No

One (1) controller indicated - Yes, less than standard speakers

6. What is your opinion of the physical placement of the speakers?

Three (3) controllers indicated - Directly overhead is good.

Two (2) controllers indicated - Directly overhead is hazardous.

One (1) controller indicated - At standard speaker locations.

One (1) controller indicated - In front of controllers.

Three (3) controllers indicated - No comment.

10. Traffic load

light (12), medium, (0), heavy, (0)

11. Position which you are evaluating?

One (1) - Positions 2 & 3

Nine (9) - Position 4

Three (3) - Position 5

One (1) - Position 6

APPENDIX II

EXCERPTS FROM SIMULATOR OPERATIONAL TEST SCRIPT

EXCERPTS FROM
SIMULATOR OPERATIONAL TEST SCRIPT

Test 7. Three subjects transmit simultaneously:

Subject A dial 914 and deliver the following message:

"Pittsburgh Center, this is Ant 37, a flight of 16 B-47's. We are part of the racetrack block, blue cell. We are aborting our mission and we'll be proceeding in flights of four aircraft on four individual flight plans. We'll be Ant 37, Ant 81, Ant 18, and Ant 23. We are presently three minutes south of Morgantown, Marsa. 37 is at flight level three one zero, 81 at flight level three one five, 18 at flight level three two zero, and 23 at flight level three two zero. We'd like to pick up our IFR clearance at Morgantown. Roger Pit. We'll stand by to pick up our IFR clearances at Morgantown. Roger Pit. We'll stand by."

Subject B dial 910; deliver the following message:

"New York Center, Tiger Silver approaching West Chester from the south requesting a penetration to Philly International. We are minimum fuel. We're now at flight level three eight zero and in the clear."

Subject C dial 907; deliver following message:

"Washington Center, trans Canada 266 over Morgantown at three seven, one three thousand estimating Elkins at four four. We've been having minor engine trouble with Number 4 and we'd like a lower altitude and a clearance to Washington National. Any routing. At this time, there doesn't appear to be any immediate danger. We are not, I repeat, NOT declaring an emergency."