

6333

403362

ASIA
AD No.

Emitter Materials Study Thermionic Energy Converters

FORD INSTRUMENT COMPANY
DIVISION OF SPERRY RAND CORPORATION

31-10 Thomson Avenue, Long Island City 1, N. Y.

Contract No. NONR-3696 (00)

Task No. 391-429

FINAL TECHNICAL REPORT

December 31, 1962

DDC
MAY 14 1963
RECEIVED
ASIA A

POWER BRANCH

OFFICE OF NAVAL RESEARCH
Washington 25, D.C.

OFFICE OF NAVAL RESEARCH

CONTRACT Nonr 3696(00)

Task No. NR 391-429

FINAL TECHNICAL REPORT

EMITTER MATERIALS STUDY

THERMIONIC ENERGY CONVERTERS

NUCLEAR DEVELOPMENT DIVISION
FORD INSTRUMENT COMPANY
Division of Sperry Rand Corporation
Long Island City 1, N.Y.

December 31, 1962

Reproduction in whole or in part is permitted for any
purpose of the United States Government

FOREWARD

This report was initiated by the Power Branch, Office of Naval Research, Washington 25, D.C. The research and development work upon which this report is based was accomplished by the Nuclear Development Division, Ford Instrument Company, Division of Sperry Rand Corporation, Long Island City, New York, under the Office of Naval Research Contract Nonr 3696(00) FBM, "Emitter Materials Study-Thermionic Energy Converters." (Dr. John J. Connelly Jr. monitored the project for the Power Branch.)

The research and development was directed by M. Silverberg - Engineering Department Head, and L. L. Haring - Project Supervisor. The experiments and analysis were performed by J. Jacobs - Principal Engineer, L. Phillips and M. Cosenza - Senior Engineers, and E. Berman - Engineer. W. Franklin - Principal Engineer and R. Mercer - Assistant Engineer were responsible for device fabrications.

ERRATA

EMITTER MATERIALS STUDY - THERMIONIC ENERGY CONVERTERS

FINAL TECHNICAL REPORT DEC. 31, 1962

CONTRACT NO. Nonr-3696(00)

TASK NO. 099 - 365

| <u>Page</u> | <u>Line</u> | <u>Error</u> | <u>Correction</u> |
|-------------|-------------|---------------------|---------------------|
| Cover | 8 | Task No. NR 391-429 | Task No. NR 099-365 |
| 2, 3 | 9, 10 | phenomena | phenomenon |
| 11 | 17 | of such | such |
| 12 | 23 | I vs V vs V | I vs V |
| 15 | 10 | psacing | spacing |
| 17 | 26 | . Also, for | , at |

ABSTRACT

An experimental program was conducted on selected emitter materials to determine their potential for use in low temperature thermionic energy converters. One oxide emitter and four different dispenser types were evaluated in parallel plate and cylindrical geometry in both glass and metal ceramic construction. With respect to power density the various dispenser emitter types showed suitable and reasonably similar performance. Performance degradation was reversed in some of these diodes and its mechanism explored and explained.

NOMENCLATURE

| | |
|-------------------------|--|
| B - | Philips Type Impregnated Tungsten Emitter (See Appendix A for Chemical Composition) |
| CCC - | Sylvania Oxide Emitter (See Appendix A for Chemical Composition) |
| d - | Interelectrode Spacing |
| E_m - | Emitter Material |
| S-70) S-80) S-85) | Semicon Associates Type No. (See Appendix A for Chemical Composition) |
| TC - | Test Cell |
| T_c - | Collector Temperature |
| T_{cs} - | Cesium Temperature |
| T_e - | Emitter Brightness |

TABLE OF CONTENTS

| <u>CHAPTER</u> | | <u>PAGE</u> |
|----------------|--|-------------|
| | FOREWORD | ii |
| | ABSTRACT | iii |
| | NOMENCLATURE | iv |
| I. | INTRODUCTION | 1. |
| II. | ACCOMPLISHMENTS AND CONCLUSIONS | 2. |
| | A. Significant Program Accomplishments | 2. |
| | B. Conclusions | 2. |
| | C. Recommendations | 4. |
| III. | EMITTER SELECTION CRITERIA | 5. |
| IV. | TEST CELL GEOMETRY AND PROCESSING | 8. |
| V. | EXPERIMENTAL PROCEDURES AND TECHNIQUES | 11. |
| VI. | TEST RESULTS | 14. |
| VII. | SLUMP REVERSAL STUDIES | 19. |
| VIII. | REFERENCES | 22. |
| IX. | APPENDIX | 23. |
| X. | TABLES | 24. |
| XI. | ILLUSTRATIONS | |

LIST OF TABLES

TABLE

| | |
|----|--|
| 1 | Table of Emitting Materials and Their Characteristics |
| 2 | Test Results of TC-173 (E _M - Semicon Type S-70) |
| 3 | Test Results of TC-178 (E _M - Semicon Type S-70) |
| 4 | Test Results of TC-196 (E _M - Semicon Type S-85) |
| 5 | Test Results of TC-EC-3 (E _M - Semicon Type S-85) |
| 6 | Test Results of TC-225 (E _M - Semicon Type S-85) |
| 7 | Test Results of TC-229 (E _M - Semicon Type S-85) |
| 8 | Test Results of TC-240 (E _M - Semicon Type S-80) |
| 9 | Test Results of TC-241 (E _M - Semicon Type S-85) |
| 10 | Test Results of TC-242 (E _M - Semicon Type S-70) |
| 11 | Test Results of TC-243 (E _M - Semicon Type S-70) |
| 12 | Test Results of TC-222 (E _M - Philips Type "B") |
| 13 | Test Results Summary |

LIST OF ILLUSTRATIONS

Figure

1. Planar Geometry
2. Planar Geometry Assembly
3. Cylindrical Geometry
4. Cylindrical Geometry
5. Cylindrical Geometry
6. Cylindrical Geometry Assembly
7. Opposed Cup Metal Ceramic Geometry
8. Opposed Cup Metal Ceramic Assembly
9. Circuit Diagram for Measuring Vacuum Emission
- 10A. Heater Voltage vs Time
- 10B. Collector Voltage vs Time
11. Simplified Block Diagram of Thermionic Cell Evaluation Circuitry
12. Circuit Diagram for I vs V Pulse Testing
13. Circuit Diagram for DC Testing of Cell
14. Current Density vs Output Voltage for TC #173
15. Current Density vs Output Voltage for TC #178
16. Current Density vs Output Voltage for TC #EC3
17. Current Density vs Output Voltage for TC #195
18. Current Density vs Output Voltage for TC #196
19. Current Density vs Output Voltage for TC #229
20. Current Density vs Output Voltage for TC #240
21. Current Density vs Output Voltage for TC #241
22. Current Density vs Output Voltage for TC #242
23. Current Density vs Output Voltage for TC #243

I. INTRODUCTION

The aim of this program was to select emitter materials together with appropriate geometries to determine their relative merits for use in low temperature thermionic energy converters. Extensive evaluations with these emitters were made of thermionic performance parameters such as output voltage, current, power density and resistance to poisoning. The interrelationship between specific emitter performance and environmental parameters was also substantiated. Most significantly, the mechanism of performance degradation and its reversal was explored and tentatively established.

II. ACCOMPLISHMENTS AND CONCLUSIONS

A. Significant Program Accomplishments

1. Four dispenser emitter materials were found to exhibit suitable performance in the 1100°C - 1150°C range for low temperature thermionic energy converters.

2. The first reported accomplishment of reversal of performance slump in an operating thermionic converter. The mechanism of this reversal has been explored and explained as a collector work function phenomena.

3. An extensive collection of emitter performance data has been compiled and correlated in connection with low temperature converters using various dispenser emitters, in both glass and metal ceramic construction.

4. Useful evaluation techniques have been devised and proven for obtaining reliable pulse performance data and variable collector heat in glass cells.

B. Conclusions

The four dispenser emitter materials evaluated are:

Philips Type "B"

Semicon #S-70

Semicon #S-80

Semicon #S-85

1. These have all demonstrated suitable performance in the 1100°C range for cesium plasma energy converters. The S-70 material has shown to have better power density at the lower temperature limit. It also has

better resistance to poisoning in both the processing and operating phases, because of its high barium production rate. The oxide coated emitter material which was tested was shown to be unsuitable for these devices because of its limited emission density.

2. The experiments determined that emitter poisoning was not a contributing factor to performance slump under our operating conditions. This resulted because of the high replenishment rate of barium on the surface of the emitter.

3. The cesium bath technique over the collector has demonstrated that slump is a collector poisoning phenomena. The suspected mechanism for collector cleanup is the dissolving and removing of cesium compounds by the liquid cesium bath. This buildup of cesium compounds is attributed to the long term outgassing of envelope materials at operating temperatures. For control of collector poisoning, extreme cleanliness with respect to potential outgassing constituents is required. Care must also be exercised as regarding purity of the original cesium charge and further contamination that may be introduced by virtue of the cesium release technique.

4. There is an interrelationship between the specific emitter performance and the converter environmental parameters.

a. Optimum collector temperatures for the parallel plate metal ceramic devices was found to be in the temperature range of 250°-350°C. In the cylindrical geometry devices the optimum temperature peak is at 450°C.

b. Increasing the spacing of the cylindrical devices from 0.100" to 0.175" showed considerable increase in power density.

c. The collector work function of any of the test diodes appeared to be unaffected by the wide range of emitter evaporation rates.

C. Recommendations

1. On the basis of the results of this program there are a number of suitable dispenser emitters for this temperature range. Further life testing is required to fully establish these relative merits.

2. Further study of the sensitive parameters and mechanisms of the phenomena of performance degradation should be carried out.

3. Inasmuch as slump appears to be a collector phenomenon, a study is warranted of the properties of various collector materials and their resistance to slump.

4. These emitter materials and a number of others not studied under this program are deserving of further attention, especially under different conditions of operation, e.g., higher cesium pressure and closer spacing.

III. EMITTER SELECTION CRITERIA

Early in the program a survey was taken to determine the available data on types of emitter materials which could be suitable for low temperature thermionic devices. Table I summarizes the data obtained in this survey.

Furthermore, a number of desired goals for emitter materials for long lived, high performance, nuclear-thermionic applications were developed. This was used as a guide in evaluating the multitude of various emitters in the 1000°C - 1300°C range.

1. Electron Emission - A level of 10 amperes per square centimeter is required if one expects a useful power density from the converter. This figure will include cesium enhancement.

2. Life - The drop of emission over a 15,000-hour period should not exceed 10%.

3. Evaporant Material and Rate - High rates are associated with high emission while low rates usually reflect long life. But the most important effect is on the collector work function. In this case, the material evaporated is equally as important as the rate at which it leaves the emitter surface. As a result, methods for adjusting both the kind and quantity of evaporants must be considered.

4. Workability and Joining Properties - The ease of fabricating the material into the ultimate geometries required either by machining, spinning, drawing, pressing, etc., is extremely important. The capability of joining the emitter material to fuel surfaces, structural supports and lead surfaces by reasonable brazing and/or welding techniques must also be considered.

5. Structural Strength - The emitter materials will naturally be subjected to vibration, impact, thermal shock, etc., at operating temperature. The actual amplitude of the requirements will depend upon the reactor type and the location at the converter assemblies. In-pile requirements will certainly vary from out-of-pile installations. An example of this would be power excursion pressure surges. It is realized, therefore, that only relative comparisons of these properties between materials are possible at this time and that absolute specifications (which are dependent upon the ultimate thermal design) are premature.

6. Poisoning Resistance - The emitter should not exhibit any deterioration relative to cesium liquid or vapor. Also normal outgassing of converter materials at operating temperature should not severely affect emission for periods of 15,000 hours. Resistance to fission product gas diffusion and $n-\alpha$ reactions resulting in helium gas is important, but the necessary system information is not yet available at this time.

7. Radiation Resistance - In order to discuss this criterion in a reasonable manner, a short digression relative to converter location is necessary. Thermionic converters can be incorporated into a nuclear reactor system in one of three ways: in-pile, pile-surface, and out-of-pile. For marine power reactors, in-pile or out-of-pile converters appear possible.

The in-pile concept is one in which the thermionic cells are integrated with the reactor fuel elements. For this concept fast reactors have been considered by others for space application to achieve a minimum weight power plant and to reduce the poisoning effects of cell introduction. In such designs for power reactors in the megawatt range, materials would be subjected to the fast neutron fluxes in the order of 2×10^{14} n/cm² sec. In many Naval applications where thermal watercooled reactors are used the fast reactor design problem of obtaining acceptable fuel

volume fractions is replaced by one of minimizing the amount of thermal neutron-capturing materials within the core. In a thermal design the fast neutron flux will be reduced to about 6×10^{13} neutrons/cm² sec, but the gamma dose rate from primary gammas and fission product gammas will be similar to that in fast reactors, between 5×10^8 to 1×10^9 R/hr. The level of thermal neutron flux will be of the order of 10^{14} neutrons/cm² sec, but it is realized that radiation damage is less severe with lower energy neutrons.

In out-of-pile systems the converters are removed from the reactor core and the emitters receive heat from the coolant in the primary loop. One advantage of this technique is the reduction in radiation environment. The gamma dose rate at the converter with a lithium coolant would be four to five decades lower than the in-pile case, while slow and fast neutron fluxes would be negligible from a materials point of view. The basic disadvantage of this system lies in the containment of corrosive liquid metals and metal salts at 1200°C temperatures necessary even for low temperature emitters.

8. Availability - A practical limitation on the choice of emitter materials for immediate application is procurement. Those materials which have an extensive background of statistical operating experience were heavily weighted in our selections for this program.

III. TEST CELL GEOMETRY AND PROCESSING

Three basic types of test cell configurations were chosen for the evaluation and comparison of the emitter materials selected. Test cells, employing glass envelopes, were constructed in both planar and cylindrical geometries as shown in Figures 1 through 6, respectively. Diodes of these types were found suitable for initial tests due to their ease and economy of manufacture although adequate parameter control, especially that of collector temperature control was not obtained with the same facility, as in a metal ceramic cell. However, some degree of collector temperature variation was accomplished (see Experimental Techniques). In addition, some two hundred (200) similar glass cells employing Philips types A and B emitters, during the past few years were made at the Ford Instrument Company, all of which form a good basis of comparison for new material in the same geometries.

The metal-ceramic construction with its external collector and more flexible electron gun design for emitter heating eliminated the above mentioned difficulties. Two such cells, TC-225 and TC-229 as shown in Figures 7 and 8 were fabricated with impregnated tungsten emitters manufactured by Semicon Associates, Inc., with the designation S-85. This material was selected for further evaluation in the metal-ceramic design after having shown promising performance early in the program. Again, as in the case of the glass cells, extensive comparison data was available on many metal-ceramic cells of the same geometry with the Philips Type "B" emitters.

Both geometries were used in the program. Some of the advantages of the cylindrical geometry used in the test cell were as follows:

1. Better axial symmetry and reduced end effects
2. Better simulation of ultimate heat source configuration
3. Higher measured efficiencies possible in test cells
4. Minimum support emission phenomena

There are limitations, nevertheless, to cylindrical geometry, and these are:

1. Limitations in collector-emitter area ratios
2. Higher possibility of emitter-heater interactions. Consequently, both cylindrical and parallel plate geometries were evaluated and compared during the program.

Two basic similarities exist in the processing of all cells containing impregnated tungsten emitters. These emitters were pre-aged on the pump for approximately 100 hours at their activation temperature prior to tip-off and their collectors were heated to a temperature somewhat greater than 1300°C just before tip-off. Treating a cell collector this way, eliminated the heavy layer of emitter evaporants (Ba and BaO) (Ca and CaO) which would otherwise form on the collector due to the high initial emitter evaporation rate; this processing also brought the conditions of the emitter to such a point that subsequent emitter evaporation would occur at a considerably reduced rate. We found it desirable to hydrogen fire molybdenum parts at 1700° for 10 minutes prior to assembly.

At various times during the life of the cell on the pump, the condition of the emitter was checked by measuring its saturation current density by Shottky extrapolations. (See Figure 9).

After the final collector outgassing, the cell was allowed to

cool, then the cesium ampule was broken. The cesium was slowly distilled from the ampule into the cell and the final tip-off was made. The composition of the cesium used is listed in the Appendix.

V. EXPERIMENTAL PROCEDURES AND TECHNIQUES

1. Instrumentation:

A) Emitter Heat Source:

In the planar and cylindrical glass cells evaluated, the operating temperature of the emitters was achieved by applying a 60 cycle half wave pulse to a heater which was inserted inside the cylindrical emitter. (See Figure 10A) The positive side of the heater was tied to the emitter so that the heater would be negative with respect to the emitter. This procedure minimized emission from the emitter to the heater.

In the metal ceramic cells evaluated, the emitters were heated by electron bombardment.

B) Firing Pulse with Time Delay for I vs V Characteristic:

During the off cycle of the heater, a period of 8 milliseconds, a triangular pulse was used to fire the cell. (See Figure 10B) The pulse width and phase with respect to the on cycle of the heater was adjustable. The current vs voltage characteristic was measured only during the off cycle of the heater. This procedure eliminated side effects of such as ion storage in the cell due to heater voltage on during the duration of the collector firing pulse.

C) Collector Temperature Control:

In the glass cells, in order to determine the effect of variation of collector temperature on the I vs V characteristic, a collector heat pulse was available. This pulse was square and had variable width so that the collector power could be controlled. This pulse occurred only during the on cycle of the heater, so that ion storage effects from this pulse, would not interfere with the true I vs V characteristic.

In the metal ceramic cell, the collector temperature was controlled by regulating the power input to a helical heater imbedded in a copper conductor-convector which was placed inside the collector cup. Thermocouple leads were attached in order to measure the collector temperature.

D) Cesium Temperature Control:

The glass cells were evaluated in a temperature controlled oven, the ambient temperature of the oven was recorded as the cesium temperature. Cesium temperature was varied by either raising or lowering the thermostat setting of the oven.

In the metal ceramic cells, the cesium temperature was controlled by regulating the power into a flexible heater tape which was wrapped around the cesium heat sink. An iron-constantan thermocouple was used as the sensor of a preset temperature controller which regulated the cesium temperature.

E) Emitter Brightness:

Emitter brightness was measured by means of an optical pyrometer and adjusted manually.

2. Test Procedures:

I vs V Characteristic:

Two methods were employed in establishing the current vs voltage characteristic of each device.

a) In the glass cells, I vs V vs V characteristics were determined using the circuitry shown in Figures 11 and 12 in the following manner. At a specified emitter temperature, collector temperature

and cesium temperature, the voltage developed across a current sensing, resistor was fed into the vertical axis of a Tektronix scope. The thermionic voltage developed across the cell itself was fed into the external sweep of the scope. In this manner, a curve of current versus voltage appeared across the screen. With the aid of a Dumont Scope camera and employing Polaroid 3000 film, permanent displays of the I vs V characteristics were recorded.

b) The metal ceramic cells were ignited using a variable DC supply with a one ohm load in series with the cell as shown in Figure 13. The procedure used in optimizing the output power was as follows. At a particular emitter brightness, the cell was fired by increasing the DC voltage available to the cell. An ammeter in series with the cell registered the output current. A 2000mv full scale voltmeter was connected between the collector and emitter.

Keeping the output current and the emitter brightness constant, the cell power output was optimized by first varying the cesium temperature and observing the cell voltage. The cesium temperature was raised or lowered until the output voltage of the cell was optimized. Then, keeping the cell current, emitter brightness and cesium temperature constant, the collector temperature was varied until the output voltage again reached a maximum. This procedure would then be repeated until the output voltage was maximum. Keeping the optimum collector temperature and the optimum cesium temperature constant the current could be varied from short circuit to a minimum and noting the output voltage. It was necessary to adjust the electron gun power in order to correct for changes in emitter temperature due to electron cooling.

VI. TEST RESULTS

For each glass cell tested, which included planar and cylindrical geometries, current vs. voltage characteristics were taken using a time-varying collector triangular wave form which plotted the current-voltage characteristic immediately on the oscilloscope. Extensive parameter studies were made in a short period of time using such a technique. Test cells #173, 178, 196, EC3, 240, 241, 242 and 243 were tested in this manner. Results are shown in Tables 2, 3, 4, 5, 8, 9, 10 and 11. Typical I vs V characteristics are shown in Figures 14 through 23.

In order to attain better parameter control in our evaluation, two metal-ceramic cells were designed and tested using the Semicon type S-85 emitter. The results of these cells were compared with a typical metal-ceramic cell employing the Philips type B emitter. DC data was taken on these cells, (TC-222, 225 and 229). The point by point DC method best simulates actual operating conditions although electron cooling effects and change in collector temperature due to variable electron heating must be adjusted at each point. Circuit diagram for this technique is shown in Figure 13. Experimental results are shown in Tables 6, 7 and 12.

TC-173:

TC-173 had reasonable vacuum pulsed emission, $\frac{17 \text{ amps}}{\text{cm}^2}$ although its output power as a thermionic converter was only $\frac{.24 \text{ watts}}{\text{cm}^2}$ at 1150° emitter brightness. This low output was probably due to severe collector contamination as a result of insufficient vacuum aging for an emitter (S-70) with such a high content of emitter impregnants. Cell geometry is shown in Figure 3.

TC-178:

TC-178 delivered .6 watt/cm² at 1100°C emitter brightness but its performance does not compare with later S-70's (TC-242 and TC-243). TC-178 had a collector similar to TC-173 except that its length had been increased to 1-1/4". (See Figure 4) From the results of tests on these types of cells in the past it was apparent that good performance could be obtained at somewhat larger collector to emitter spacings with the additional benefit of lowering the minimum collector temperature by reducing the amount of energy per cm² intercepted by it. Consequently, cells were made with a collector to emitter spacing of .172" instead of .110" which was previously used. In addition, the collector length was increased to 1-1/2" and larger cooling fins were added (see Figure 5).

Two later cylindrical cells, TC-242 and TC-243 were fabricated and tested using the new collector configuration with the same size S-70 emitters. Resulting power densities of approximately 1 watt/cm² at emitter brightness as low as 1100°C were recorded.

TC-195:

TC-195 was a cylindrical cell fabricated with a Sylvania oxide emitter (55% Ba CO₃, 40% Sr CO₃, 5% Ca CO₃) coated on a 225 nickel alloy base designated CCC. Although this emitter did not appear suitable because of its low level of emission, it was readily available and tried. The cells thermionic output was negligible.

TC-196:

Planar cell TC-196 was fabricated with an impregnated tungsten emitter (Semicon S-85) which has a barium calcium aluminate mixture different from Philips Type B. (See Appendix for chemical composition).

A number of runs at different cesium and emitter temperatures were taken in order to survey the emitter's capability in our standardized planar geometry. Table 4 summarizes some of the pertinent data which showed encouraging possibilities. The use of a high voltage pulse on the collector in determining the I vs V characteristic of this cell probably gave a large degree of avalanching with accompanying high degree of ionization. This enhanced ionization at least in part was responsible for the high current density found here. In future tests such high pulses were avoided. In addition, the data below 1000°C is, somewhat optimistic due to cesium enhanced molybdenum skirt emission. At temperatures above 1100°C the skirt emission phenomenon should be negligible according to the Houston emission curves at 200°C bulb temperatures.

In order to completely avoid skirt emission, the next cell designed and tested had cylindrical geometry with negligible support area.

TC-EC3:

In order to explore more fully the characteristics of the Semicon S-85 (impregnated tungsten emitter) a cylindrical unit was fabricated and analyzed. Its geometry is shown in Figure 5.

The performance of the cell fell below that expected on the basis of the parallel plate unit (TC-196). In comparing the data shown in Table 5 and Figure 16 with TC-196 data, it was observed that the voltages of EC-3 were higher, while its current density was considerably lower. This indicated an increase in emitter work function. Subsequent emission checks showed this to be the case. The cause of this was assumed to be emitter poisoning which was verified by observing cesium oxide within the envelope.

TC-225 and TC-229:

The results of TC-225 and TC-229 were similar to TC-222. The power density of TC-229 employing S-85 emitter was approximately 1.0 watt/cm² at 1150°C emitter brightness and cesium temperature 168°C. While, TC-222 employing the Philips type "B" emitter showed a power density of 1.11 watt/cm² at 1190° emitter brightness and 173° cesium temperature. Tables 6, 7 and 12 show the test results of the cells. Due to better collector temperature control, extensive parametric runs were made on TC-229. It was noted that at cesium temperature of 168°C and an emitter brightness of 1150°C, the power density fell off less than 10% for a collector temperature range from 258°C to 357°C. Also, with the collector temperature constant at 276°C and the emitter brightness at 1150°C, the power density decreased from .87 watts/cm² to .73 watts/cm² as the cesium temperature was varied from 195°C to 141°C.

TC-240:

For TC-240 (emitter material S-80), the maximum output power occurred at cesium temperature of 220°C and collector temperature of 490°C. At cesium temperature of 180°C, the output power decreased for increased collector temperature (range 300°C - 490°C) at 1100, 1150, and 1190°C emitter brightness. Conversely, at cesium temperatures of 200 and 220°C, the output power increased for increased collector temperatures (300°C - 470°C) at 1100, 1150 and 1190°C emitter brightness.

TC-241:

For TC-241 (emitter material S-85), the maximum power occurred at cesium temperature of 200°C and 490°C collector temperature. At cesium temperatures from 180°C to 200°C, the output power increased for increased collector temperatures (300°C - 470°C). Also, for emitter brightness from 1100°C - 1190°C.

TC-242 and TC-243:

For TC-242 and TC-243 (emitter material S-70) maximum power occurred at cesium temperature 210°C and collector temperature 470°C.

At 180°C cesium temperature, the output power decreased as the collector temperature was increased from 300°C to 470°C.

At cesium temperature of 200°C the output power increased for increased collector temperatures (300°C - 490°C).

VII. SLUMP REVERSAL STUDIES

Considerable insight into the process of slump or performance degradation was obtained in the course of testing TC-229. After processing and removal from the pump, this unit exhibited the following performance data:

| | |
|-----------------------|-------------|
| Emitter Brightness | 1100°C |
| Cesium Temperature | 186°C |
| Collector Temperature | 295°C |
| Power | 0.246 watts |
| Voltage | 0.082 volts |
| Current | 3 amps |

After approximately three hours of testing, the cell had become passive and would deliver no output power. A collector bathing technique was employed that consisted of cooling the collector and raising the cesium pressure to permit liquid cesium to continually condense onto and drip off the collector. This process was permitted to continue overnight. The following morning, the parameters were re-optimized and the following data resulted:

| | |
|-----------------------|-------------|
| Emitter Brightness | 1150°C |
| Cesium temperature | 168°C |
| Collector temperature | 276°C |
| Power | 1.1 watts |
| Voltage | 0.365 volts |
| Current | 3 amps |

Similar behavior was encountered with other units particularly TC-209, which was an opposed cup design using a 1/4" diameter Philips type B

emitter. The following data obtained with TC-209 is quite striking. In all cases the emitter brightness was maintained at 1150°C.

| <u>Life(Hours)</u> | <u>Cesium Bath</u> | <u>Power Density (watts/cm²)</u> | <u>Percent Change</u> |
|--------------------|--------------------|---|---------------------------|
| 200 | | 2.50 | |
| 2200 | | 1.50 | -40 |
| 2200 | Yes | 2.26 | +50 |
| 3300 | | 1.68 | -26 |
| 3300 | Yes | 1.95 | +16 |
| 4000 | | 1.50 | -23 |
| 4000 | Yes | 1.80 | +20 |

Measurements of the work function of metals covered with cesium are usually carried out with surfaces that are prepared to be initially clean and in environments that are relatively free of contaminants. Furthermore, such measurements are generally conducted at elevated surface temperatures which tend to remove surface contaminants by evaporation. Surface deposits on an electrode with cesium coverage which do not readily evaporate can logically be expected to raise its work function and this process can be expected to be a continuing effect. In any cesium converter it is logical to anticipate a greater accumulation of surface contamination on the collector than the emitter because of lower evaporation rates at lower temperature. In addition, the output of a converter can be more sensitive to changes in work function of the collector than of the emitter. The impregnated type of emitter is particularly resistant to poisoning by virtue of its dispenser action.

The cesium bathing technique described above serves as a simple and effective means of removing surface contaminants from the collector.

The exact nature of the contaminants in the experiments performed under this program is not specifically known. The three likely sources are:

1. Evaporants from the emitter
2. Diffusion to the collector surface of material impurities
3. Cesium compounds formed with gaseous impurities present

Emitter evaporants are not a likely source because of long time scale of slump in cells such as TC-209 - thousands of hours as compared to high evaporation rates. Diffusion is rather unlikely because of the low operating temperatures of the collector - about 300°C. Cesium compounds formed on the surface of the collector with impurity gases is by far the most likely cause of the slump phenomenon. Furthermore, it is known that cesium oxides are soluble in liquid cesium. It is therefore reasoned that the slump reversal mechanism encountered entailed the solution of surface deposits such as cesium oxide in the cesium bath. This work indicates the need for cleanliness and impurity control in cesium converters.

VIII. REFERENCES

1. W. H. Kohl, Materials and Techniques for Electron Tubes, Rheinhold Pub. Corporation (1960)
2. R. W. Fane, Modern Thermionic Cathodes, Wireless World, 63, 485, (October 1957)
3. D. A. Wright, A Survey of Present Knowledge of Thermionic Emitters, IEE Proceedings, Part III, Radio and Communications Engineering, 100, 125 (1953)
4. V. L. Stout, Dispenser Cathodes, Proc. 4th Nat. Conf. Tube Techniques, September 10-11, 1958, p. 178
5. R. W. Fane, A Sintered Nickel Matrix Cathode, British Journal Applied Physics, 9, 149 (April 1957)
6. A. H. Beck, A. D. Brisbane, A. B. Cutting and G. King; A New Type of Diffusion Cathode, LeVide 9, 302 (1954)
7. J. H. Affleck, Thin Film Emitters on Refractory Substrates, Advances in Tube Techniques, Pergamon Press (1961) p. 137
8. O. G. Koppius, Impregnated Tungsten Cathode Structures and Methods for Fabricating Same Patent #3,076,916 Filed Jan. 21, 1959
9. R. Levi, Improved "Impregnated Cathode", Jour. of Applied Physics, Vol. 26, No. 5, May 55

IX. APPENDIX

A) Chemical Composition of Emitter Materials Studied

Semicon Associates Inc.:

Type S-70, 30% porosity tungsten
4 Mols BaO, 1 Mol CaO, 1 Mol Al₂ O₃

Type S-80, 20% porosity tungsten
4 Mols BaO, 1 Mol CaO, 1 Mol Al₂ O₃

Type S-85, 15% porosity tungsten
4 Mols BaO, 1 Mol CaO, 1 Mol Al₂ O₃
(Reference 8)

Philips Laboratories:

Type B, 17% porosity tungsten
5 Mols BaO, 3 Mols CaO, 2 Mols Al₂ O₃
(Reference 9)

Sylvania:

Oxide Emitter, 55% BaCO₃, 40% SrCO₃, 5% CaCO₃
coated on a 225 nickel alloy base

B) Chemical Composition of Cesium

Dow Chemical Corporation:

| <u>Detectable Impurities</u> | | <u>Not Detected</u> | |
|------------------------------|-----|---------------------|------|
| Element | PPM | Element | PPM |
| Na | 24 | Ba | < 8 |
| K | 45 | B | < 16 |
| Rb | 270 | Cr | < 2 |
| Al | 5 | Cu | < 2 |
| Ca | 10 | Li | < 16 |
| Fe | 6 | Ni | < 2 |
| Mg | 2 | Mn | < 2 |
| Si | 29 | Pb | < 2 |
| O | 36 | Sn | < 8 |
| | | Sr | < 2 |
| | | Ti | < 2 |
| | | Tl | < 2 |

TABLE 1A

| MATERIAL | REF. | RICHARDSON WORK FUNCTION ϕ VOLTS | TEMPERATURE COEFFICIENT α VOLTS/ $^{\circ}$ K | TRUE WORK FUNCTION $\phi = \phi_0 + \alpha T$ VOLTS | OPERATING TEMPERATURE $^{\circ}$ K | TEMPERATURE $^{\circ}$ K FOR CURRENT DENSITY 1 A/ CM^2 | TEMPERATURE $^{\circ}$ K FOR CURRENT DENSITY 10A/ CM^2 |
|--|-------|---|---|--|--|--|--|
| L - Cathode | 1,2,4 | 1.68 | 3.24×10^{-4} | 2.13 | 1400 | 1280 | 1450 |
| Impregnated Cathode Type A | 1,4 | 1.53 | 5.73×10^{-4} | 2.33 | 1400 | 1400 | 1650 |
| Impregnated Cathode Type B | 1,4 | 1.77 | 3.2×10^{-4} | 2.22 | 1400 | 1220 | 1500 |
| Pressed Cathode (Ba Aluminate) | 1,4 | 1.7 | 3.7×10^{-4} | 2.21 | 1400 | 1330 | 1550 |
| Pressed Cathode (BaCa Aluminate) | 1,4 | 1.7 | 3.37×10^{-4} | 2.17 | 1400 | 1300 | 1500 |
| Oxide Cathode | 2,3 | 1.48 | 1.8×10^{-4} | 1.66 | 1000 | 1050 | 1180 |
| Nickel Matrix | 2,5 | 1.07 | 5.6×10^{-4} | 1.58 | 1010 | 1010 | 1200 |
| Boriated Nickel | 6 | 1.78 | 2.5×10^{-4} | 2.10 | 1270 | 1270 | 1460 |
| W+BaSi ₄ (10%) | 7 | 1.81 | 4.7×10^{-4} | 2.15 | 1250 | 1520 | 1760 |
| WC+BaSi ₄ (10%) | 7 | 1.71 | 4.6×10^{-4} | 2.29 | 1250 | 1410 | 1650 |
| W ₂ C+BaSi ₄ (10%) | 7 | 2.00 | 2.24×10^{-4} | 2.28 | 1250 | 1360 | 1520 |
| WSi ₂ +BaSi ₄ (10%) | 7 | 2.25 | 1.1×10^{-4} | 2.39 | 1250 | 1450 | 1630 |
| W ₂ B ₅ +BaSi ₄ (10%) | 7 | 2.30 | 4.3×10^{-4} | 2.84 | 1250 | 1700 | 2080 |

TABLE 1B

| MATERIAL | EMISSION AT OPERATING TEMPERATURE AMPS/CM ² | LIFE AT OPERATING TEMPERATURE HOURS | EVAPORATION RATE AT | | |
|--|---|--|-------------------------|----------------------|-----------------------|
| | | | OPER. TEMP. | 10 A/CM ² | |
| | | | gm/CM ² /Sec | 1 A/CM ² | 10 A/CM ² |
| L- Cathode | 5 | 15,000 | 8×10^{-10} | 10^{-11} | 10^{-9} |
| Impregnated Cathode Type A | 1 | 8,000 | 10^{-10} | 10^{-10} | 10^{-9} |
| Impregnated Cathode Type B | 2.5 | 15,000 | 10^{-11} | 3×10^{-13} | 4.5×10^{-10} |
| Pressed Cathode (Ba Aluminate) | 2.5 | 5,000 | | | |
| Pressed Cathode (BaCa Aluminate) | 3.5 | 10,000 | 10^{-11} | 10^{-13} | 10^{-10} |
| Oxide Cathode | 0.5 | 5,000 | 4×10^{-12} | | |
| Nickel Matrix | 1 | 5,000 | | | |
| Boriated Nickel | 1 | 5,000 | | | |
| W+BaSi ₄ (10%) | 0.04 | | 10^{-4} | 10^{-2} | |
| WC+BaSi ₄ (10%) | 0.12 | | 3×10^{-7} | 3×10^{-6} | |
| W ₂ C+BaSi ₄ (10%) | 0.12 | | 1.2×10^{-6} | 8×10^{-6} | |
| WSi ₂ +BaSi ₄ (10%) | 0.045 | | 8×10^{-8} | 10^{-6} | |
| W ₂ B ₅ +BaSi ₄ (10%) | 0.008 | | 5×10^{-9} | 7×10^{-6} | |

TABLE 2.

TC-173
Cylindrical
EM= S-70

| <u>Emitter Br.</u> <u>°C</u> | <u>Cesium T</u> <u>°C</u> | <u>Current</u> <u>Amps</u> | <u>Voltage</u> <u>Volts</u> | <u>Power</u> <u>Watts</u> | <u>Power Density</u> <u>Watts/cm²</u> |
|---------------------------------|------------------------------|-------------------------------|--------------------------------|------------------------------|---|
| 1100 | 200 | .8 | .2 | .16 | .135 |
| 1150 | 200 | 1.4 | .2 | .28 | .24 |

TABLE 3.

TC-178
Cylindrical
EM= S-70

| <u>Emitter Br.</u> <u>°C</u> | <u>Cesium T</u> <u>°C</u> | <u>Current</u> <u>Amps</u> | <u>Voltage</u> <u>Volts</u> | <u>Power</u> <u>Watts</u> | <u>Power Density</u> <u>Watts/cm²</u> |
|---------------------------------|------------------------------|-------------------------------|--------------------------------|------------------------------|---|
| 1150 | 240 | 1.4 | .4 | .56 | .47 |
| 1150 | 240 | .8 | .8 | .64 | .54 |
| 1150 | 240 | .6 | 1.0 | .60 | .51 |
| 1150 | 240 | .4 | 1.2 | .48 | .41 |

TABLE 4.TC-196
Planar
EM-S-85

| <u>Emitter Br.</u> <u>°C</u> | <u>Cesium T</u> <u>°C</u> | <u>Current</u> <u>Amps</u> | <u>Voltage</u> <u>Volts</u> | <u>Power</u> <u>Watts</u> | <u>Power Density</u> <u>Watts/cm²</u> |
|---------------------------------|------------------------------|-------------------------------|--------------------------------|------------------------------|---|
| 990 | 200 | 0.2 | 0.4 | .08 | 1.1 |
| 1050 | 200 | 0.4 | 0.4 | .16 | 2.3 |
| 1100 | 200 | 0.6 | 0.38 | .23 | 3.2 |
| 1145 | 200 | 0.5 | 0.6 | .30 | 4.2 |
| 1175 | 200 | 1.0 | 0.4 | .40 | 5.6 |
| 990 | 210 | 0.2 | 0.4 | .08 | 1.1 |
| 1050 | 210 | 0.4 | 0.4 | .16 | 2.3 |
| 1100 | 210 | 0.6 | 0.4 | .24 | 3.4 |
| 1145 | 210 | 1.0 | 0.35 | .35 | 5.0 |
| 1175 | 210 | 1.0 | 0.41 | .41 | 5.8 |
| 1190 | 210 | 1.0 | 0.41 | .41 | 5.8 |
| 990 | 225 | 0.2 | 0.4 | .08 | 1.1 |
| 1045 | 225 | 0.4 | 0.4 | .16 | 2.3 |
| 1100 | 225 | 0.6 | 0.55 | .33 | 4.7 |
| 1150 | 225 | 1.0 | 0.39 | .39 | 5.5 |
| 1200 | 225 | 1.0 | 0.40 | .40 | 5.6 |
| 990 | 240 | 0.4 | 0.3 | .12 | 1.7 |
| 1050 | 240 | 0.4 | 0.6 | .24 | 3.4 |
| 1100 | 240 | 0.6 | 0.42 | .26 | 3.7 |
| 1150 | 240 | 1.0 | 0.3 | .30 | 4.3 |
| 1200 | 240 | 1.0 | 0.38 | .38 | 5.4 |

TABLE 5.

TC-EC3
Cylindrical
EM-S-85

| <u>Emitter Br.</u> <u>°C</u> | <u>Cesium T.</u> <u>°C</u> | <u>Current</u> <u>Amps</u> | <u>Voltage</u> <u>Volts</u> | <u>Power</u> <u>Watts</u> | <u>Power Density</u> <u>Watts/cm²</u> |
|---------------------------------|-------------------------------|-------------------------------|--------------------------------|------------------------------|---|
| 1050 | 200 | 1.0 | .80 | .80 | .68 |
| 1100 | 200 | 1.2 | .80 | .96 | .82 |
| 1150 | 200 | 1.4 | .72 | 1.01 | .85 |
| 1000 | 225 | 1.2 | .70 | .84 | .71 |
| 1050 | 225 | 1.2 | .80 | .96 | .82 |
| 1100 | 225 | 1.0 | 1.0 | 1.0 | .85 |

TABLE 6.

TC-225
Metal Ceramic
EM-S-85

| <u>Emitter Br.</u> <u>°C</u> | <u>Cesium T.</u> <u>°C</u> | <u>Collector T.</u> <u>°C</u> | <u>Current</u> <u>Amps</u> | <u>Voltage</u> <u>Volts</u> | <u>Power</u> <u>Watts</u> | <u>Power Density</u> <u>Watts/cm²</u> |
|---------------------------------|-------------------------------|----------------------------------|-------------------------------|--------------------------------|------------------------------|---|
| 1180 | 160 | 247 | 4.0 | .18 | 0.72 | .57 |
| 1190 | 160 | 209 | 4.0 | .10 | 0.40 | .32 |
| 1205 | 160 | 209 | 3.0 | .15 | 0.45 | .36 |
| 1250 | 160 | 247 | 4.1 | .40 | 1.60 | 1.26 |

TABLE 7.TC-229
Metal Ceramic
EM-S-85

| <u>Emitter Br.</u> °C | <u>Cesium T.</u> °C | <u>Collector T.</u> °C | <u>Current</u> Amps | <u>Voltage</u> Volts | <u>Power</u> Watts | <u>Power Density</u> Watts/cm ² |
|--------------------------|------------------------|---------------------------|------------------------|-------------------------|-----------------------|---|
| 1150 | 177 | 276 | 3.0 | .24 | .72 | .57 |
| 1150 | 186 | 276 | 3.0 | .18 | .54 | .43 |
| 1150 | 195 | 276 | 3.0 | .15 | .45 | .35 |
| 1150 | 204 | 276 | 3.0 | .12 | .36 | .28 |
| 1150 | 172 | 276 | 3.0 | .24 | .73 | .58 |
| 1150 | 168 | 276 | 3.0 | .24 | .72 | .57 |
| 1150 | 159 | 276 | 3.0 | .26 | .78 | .61 |
| 1150 | 141 | 276 | 3.0 | .33 | .99 | .78 |
| 1150 | 150 | 276 | 3.0 | .35 | 1.05 | .83 |
| 1150 | 159 | 276 | 3.0 | .36 | 1.08 | .85 |
| 1150 | 168 | 276 | 3.0 | .365 | 1.10 | .87 |
| 1150 | 177 | 276 | 3.0 | .35 | 1.06 | .83 |
| 1150 | 186 | 276 | 3.0 | .34 | 1.02 | .80 |
| 1150 | 195 | 276 | 3.0 | .31 | .93 | .73 |
| 1150 | 168 | 276 | 3.0 | .34 | 1.02 | .80 |
| 1150 | 168 | 276 | 2.5 | .385 | .96 | .75 |
| 1150 | 168 | 276 | 2.0 | .46 | .92 | .72 |
| 1150 | 168 | 276 | 3.25 | .315 | 1.02 | .80 |
| 1150 | 168 | 276 | 3.50 | .29 | 1.02 | .80 |
| 1150 | 168 | 276 | 3.75 | .28 | 1.05 | .83 |
| 1150 | 168 | 276 | 4.0 | .265 | 1.06 | .83 |
| 1150 | 168 | 276 | 4.25 | .24 | 1.02 | .80 |
| 1150 | 168 | 276 | 4.5 | .225 | 1.01 | .79 |
| 1150 | 168 | 276 | 4.75 | .21 | 1.0 | .79 |

TABLE 7. (cont'd)

| <u>Emitter Br.</u> <u>°C</u> | <u>Cesium T.</u> <u>°C</u> | <u>Collector T.</u> <u>°C</u> | <u>Current</u> <u>Amps</u> | <u>Voltage</u> <u>Volts</u> | <u>Power</u> <u>Watts</u> | <u>Power Density</u> <u>Watts/cm²</u> |
|---------------------------------|-------------------------------|----------------------------------|-------------------------------|--------------------------------|------------------------------|---|
| 1150 | 168 | 276 | 5.0 | .197 | .99 | .78 |
| 1150 | 168 | 276 | 3.0 | .38 | 1.14 | .90 |
| 1150 | 168 | 249 | 3.0 | .35 | 1.05 | .83 |
| 1150 | 168 | 258 | 3.0 | .385 | 1.15 | .91 |
| 1150 | 168 | 267 | 3.0 | .40 | 1.2 | .95 |
| 1150 | 168 | 276 | 3.0 | .41 | 1.23 | .97 |
| 1150 | 168 | 285 | 3.0 | .41 | 1.23 | .97 |
| 1150 | 168 | 294 | 3.0 | .415 | 1.24 | .98 |
| 1150 | 168 | 303 | 3.0 | .418 | 1.25 | .98 |
| 1150 | 168 | 312 | 3.0 | .418 | 1.25 | .98 |
| 1150 | 168 | 320 | 3.0 | .420 | 1.26 | .99 |
| 1150 | 168 | 330 | 3.0 | .42 | 1.26 | .99 |
| 1150 | 168 | 340 | 3.0 | .418 | 1.25 | .98 |
| 1150 | 168 | 348 | 3.0 | .41 | 1.23 | .97 |
| 1150 | 168 | 357 | 3.0 | .38 | 1.14 | .90 |
| 1150 | 168 | 366 | 3.0 | .355 | 1.06 | .84 |
| 1200 | 168 | 320 | 3.0 | .52 | 1.56 | 1.24 |
| 1200 | 168 | 340 | 3.0 | .50 | 1.50 | 1.19 |
| 1200 | 168 | 348 | 3.0 | .50 | 1.50 | 1.19 |
| 1200 | 168 | 357 | 3.0 | .495 | 1.49 | 1.18 |
| 1200 | 168 | 366 | 3.0 | .495 | 1.49 | 1.18 |
| 1200 | 168 | 375 | 3.0 | .495 | 1.49 | 1.18 |
| 1200 | 168 | 385 | 3.0 | .49 | 1.47 | 1.17 |
| 1200 | 168 | 394 | 3.0 | .49 | 1.47 | 1.17 |
| 1200 | 168 | 404 | 3.0 | .49 | 1.47 | 1.17 |

TABLE 7. (cont'd)

| <u>Emitter Br.</u> <u>°C</u> | <u>Cesium T.</u> <u>°C</u> | <u>Collector T.</u> <u>°C</u> | <u>Current</u> <u>Amps</u> | <u>Voltage</u> <u>Volts</u> | <u>Power</u> <u>Watts</u> | <u>Power Density</u> <u>Watts/cm²</u> |
|---------------------------------|-------------------------------|----------------------------------|-------------------------------|--------------------------------|------------------------------|---|
| 1200 | 168 | 422 | 3.0 | .485 | 1.46 | 1.16 |
| 1200 | 168 | 320 | 3.0 | .495 | 1.49 | 1.18 |
| 1200 | 168 | 312 | 3.0 | .495 | 1.49 | 1.18 |
| 1200 | 168 | 303 | 3.0 | .495 | 1.49 | 1.18 |
| 1200 | 168 | 294 | 3.0 | .495 | 1.49 | 1.18 |
| 1200 | 168 | 276 | 3.0 | .50 | 1.50 | 1.19 |
| 1200 | 168 | 258 | 3.0 | .50 | 1.50 | 1.19 |
| 1200 | 168 | 240 | 3.0 | .495 | 1.49 | 1.18 |
| 1200 | 168 | 276 | 3.0 | .535 | 1.61 | 1.27 |
| 1200 | 168 | 294 | 3.0 | .535 | 1.61 | 1.27 |
| 1200 | 168 | 312 | 3.0 | .53 | 1.51 | 1.20 |
| 1200 | 168 | 320 | 3.0 | .53 | 1.51 | 1.20 |
| 1200 | 168 | 320 | 3.0 | .55 | 1.65 | 1.31 |
| 1200 | 168 | 320 | 3.5 | .47 | 1.65 | 1.31 |
| 1200 | 168 | 320 | 4.0 | .435 | 1.74 | 1.38 |
| 1200 | 168 | 320 | 4.5 | .385 | 1.73 | 1.37 |
| 1200 | 168 | 320 | 5.0 | .335 | 1.68 | 1.33 |
| 1200 | 168 | 320 | 5.5 | .31 | 1.71 | 1.36 |
| 1200 | 168 | 320 | 6.0 | .275 | 1.65 | 1.31 |
| 1200 | 168 | 320 | 4.5 | .41 | 1.85 | 1.47 |
| 1200 | 168 | 320 | 5.0 | .355 | 1.68 | 1.33 |
| 1200 | 168 | 320 | 4.0 | .45 | 1.80 | 1.43 |
| 1200 | 168 | 320 | 3.5 | .50 | 1.75 | 1.39 |
| 1200 | 168 | 320 | 5.5 | .31 | 1.71 | 1.36 |
| 1200 | 168 | 320 | 6.0 | .275 | 1.65 | 1.31 |

TABLE 8.

TC-240
Cylindrical
EM=S-80

| <u>Emitter Br.</u> <u>°C</u> | <u>Cesium T.</u> <u>°C</u> | <u>Collector T.</u> <u>°C</u> | <u>Current</u> <u>Amps</u> | <u>Voltage</u> <u>Volts</u> | <u>Power</u> <u>Watts</u> | <u>Power Density</u> <u>Watts/cm²</u> |
|---------------------------------|-------------------------------|----------------------------------|-------------------------------|--------------------------------|------------------------------|---|
| 1100 | 180 | 365 | 1.0 | .2 | .2 | .17 |
| 1100 | 180 | 415 | .7 | .2 | .14 | .12 |
| 1100 | 180 | 450 | .3 | .2 | .06 | .05 |
| 1100 | 180 | 475 | .1 | .2 | .02 | .02 |
| 1150 | 180 | 375 | 1.4 | .2 | .28 | .23 |
| 1150 | 180 | 415 | 1.4 | .2 | .28 | .23 |
| 1150 | 180 | 450 | 1.3 | .2 | .26 | .22 |
| 1150 | 180 | 475 | 1.2 | .2 | .24 | .20 |
| 1190 | 180 | 365 | 1.6 | .2 | .32 | .27 |
| 1190 | 180 | 415 | 1.6 | .2 | .32 | .27 |
| 1190 | 180 | 460 | 1.5 | .2 | .30 | .25 |
| 1190 | 180 | 485 | 1.4 | .2 | .28 | .24 |
| 1100 | 200 | 375 | 1.0 | .2 | .20 | .17 |
| 1100 | 200 | 435 | 1.5 | .2 | .30 | .25 |
| 1100 | 200 | 460 | 1.6 | .2 | .32 | .27 |
| 1100 | 200 | 485 | 1.7 | .2 | .34 | .29 |
| 1150 | 200 | 375 | 1.7 | .2 | .34 | .28 |
| 1150 | 200 | 435 | 2.0 | .2 | .40 | .34 |
| 1150 | 200 | 460 | 2.2 | .2 | .44 | .37 |
| 1150 | 200 | 485 | 1.8 | .2 | .36 | .31 |
| 1190 | 200 | 375 | 1.7 | .2 | .34 | .29 |
| 1190 | 200 | 435 | 2.0 | .2 | .40 | .34 |
| 1190 | 200 | 460 | 2.0 | .2 | .40 | .34 |
| 1190 | 200 | 485 | 1.9 | .2 | .38 | .32 |
| 1100 | 220 | 335 | 1.0 | .2 | .20 | .17 |

TABLE 8. (cont'd)

| <u>EMITTER BR.</u> <u>°C</u> | <u>CESIUM T.</u> <u>°C</u> | <u>COLLECTOR T.</u> <u>°C</u> | <u>CURRENT</u> <u>AMPS</u> | <u>VOLTAGE</u> <u>VOLTS</u> | <u>POWER</u> <u>WATTS</u> | <u>POWER DENSITY</u> <u>WATTS/CM²</u> |
|---------------------------------|-------------------------------|----------------------------------|-------------------------------|--------------------------------|------------------------------|---|
| 1100 | 220 | 385 | 1.4 | .2 | .28 | .24 |
| 1100 | 220 | 440 | 1.7 | .2 | .34 | .29 |
| 1100 | 220 | 490 | 2.2 | .2 | .44 | .37 |
| 1150 | 220 | 335 | 1.2 | .2 | .24 | .20 |
| 1150 | 220 | 405 | 2.8 | .2 | .56 | .47 |
| 1150 | 220 | 490 | 3.6 | .2 | .72 | .61 |
| 1150 | 220 | 515 | 3.5 | .2 | .70 | .59 |
| 1190 | 220 | 385 | 2.8 | .2 | .56 | .47 |
| 1190 | 220 | 445 | 4.0 | .2 | .80 | .68 |
| 1190 | 220 | 490 | 4.2 | .2 | .84 | .71 |
| 1190 | 220 | 515 | 4.0 | .2 | .80 | .68 |

TABLE 9.TC-241
Cylindrical
EM-S-85

| <u>Emitter Br.</u> <u>°C</u> | <u>Cesium T.</u> <u>°C</u> | <u>Current</u> <u>Amps</u> | <u>Voltage</u> <u>Volts</u> | <u>Power</u> <u>Watts</u> | <u>Power Density</u> <u>Watts/cm²</u> |
|---------------------------------|-------------------------------|-------------------------------|--------------------------------|------------------------------|---|
| 1100 | 180 | 1.2 | .2 | .24 | .20 |
| 1100 | 180 | 1.4 | .2 | .28 | .23 |
| 1100 | 180 | 1.6 | .2 | .32 | .27 |
| 1100 | 180 | 2.1 | .2 | .42 | .35 |
| 1150 | 180 | 3.2 | .2 | .64 | .54 |
| 1150 | 180 | 4.0 | .2 | .80 | .67 |
| 1150 | 180 | 4.4 | .2 | .88 | .74 |
| 1150 | 180 | 4.8 | .2 | .96 | .81 |
| 1190 | 180 | 6.0 | .2 | 1.20 | 1.04 |
| 1190 | 180 | 7.6 | .2 | 1.52 | 1.28 |
| 1190 | 180 | 8.0 | .2 | 1.60 | 1.36 |
| 1190 | 180 | 8.4 | .2 | 1.68 | 1.43 |
| 1100 | 200 | 2.4 | .2 | .48 | .41 |
| 1100 | 200 | 2.4 | .2 | .48 | .41 |
| 1100 | 200 | 3.2 | .2 | .64 | .54 |
| 1100 | 200 | 3.6 | .2 | .72 | .61 |
| 1150 | 200 | 5.2 | .2 | 1.04 | .85 |
| 1150 | 200 | 6.4 | .2 | 1.28 | 1.08 |
| 1150 | 200 | 6.6 | .2 | 1.32 | 1.12 |
| 1150 | 200 | 7.2 | .2 | 1.44 | 1.22 |
| 1190 | 200 | 4.0 | .2 | .80 | .67 |

TABLE 10.TC-242
Cylindrical
EM=S-70

| <u>Emitter Br.</u> <u>°C</u> | <u>Cesium T.</u> <u>°C</u> | <u>Collector T.</u> <u>°C</u> | <u>Current</u> <u>Amps</u> | <u>Voltage</u> <u>Volts</u> | <u>Power</u> <u>Watts</u> | <u>Power Density</u> <u>Watts/cm²</u> |
|---------------------------------|-------------------------------|----------------------------------|-------------------------------|--------------------------------|------------------------------|---|
| 1100 | 190 | 320 | 3.2 | .2 | .64 | .54 |
| 1100 | 190 | 320 | 2.0 | .4 | .80 | .67 |
| 1100 | 190 | 425 | 4.0 | .2 | .80 | .67 |
| 1100 | 190 | 425 | 2.8 | .4 | 1.12 | .86 |
| 1100 | 190 | 460 | 4.6 | .2 | .92 | .78 |
| 1100 | 190 | 460 | 3.0 | .4 | 1.20 | 1.02 |
| 1150 | 200 | 325 | 1.6 | .2 | .32 | .27 |
| 1150 | 200 | 325 | 1.2 | .4 | .48 | .41 |
| 1150 | 200 | 455 | 2.8 | .2 | .56 | .47 |
| 1150 | 200 | 455 | 1.6 | .4 | .64 | .54 |
| 1100 | 200 | 325 | 1.6 | .2 | .32 | .27 |
| 1100 | 200 | 325 | 1.2 | .4 | .48 | .41 |
| 1100 | 200 | 460 | 2.4 | .2 | .48 | .41 |
| 1100 | 200 | 460 | 1.0 | .4 | .40 | .34 |
| 1100 | 200 | 510 | 1.6 | .2 | .32 | .27 |
| 1100 | 200 | 510 | .08 | .4 | .32 | .27 |
| 1100 | 210 | 470 | 4.0 | .2 | .8 | .67 |
| 1100 | 210 | 470 | 3.0 | .4 | 1.2 | 1.02 |

TABLE 11.

TC-243
Cylindrical
EM=S-70

| <u>Emitter Br.</u> <u>°C</u> | <u>Cesium T.</u> <u>°C</u> | <u>Collector T.</u> <u>°C</u> | <u>Current</u> <u>Amps</u> | <u>Voltage</u> <u>Volts</u> | <u>Power</u> <u>Watts</u> | <u>Power Density</u> <u>Watts/cm²</u> |
|---------------------------------|-------------------------------|----------------------------------|-------------------------------|--------------------------------|------------------------------|---|
| 1100 | 180 | 280 | 1.6 | .2 | .32 | .27 |
| 1100 | 180 | 445 | 1.2 | .2 | .24 | .20 |
| 1150 | 180 | 315 | 2.0 | .2 | .40 | .34 |
| 1150 | 180 | 445 | 1.6 | .2 | .32 | .27 |
| 1150 | 200 | 335 | 6.4 | .2 | 1.28 | 1.08 |
| 1150 | 200 | 465 | 6.4 | .2 | 1.28 | 1.08 |
| 1150 | 200 | 520 | 4.8 | .2 | .96 | .81 |
| 1100 | 200 | 335 | 4.8 | .2 | .96 | .81 |
| 1100 | 200 | 465 | 5.2 | .2 | 1.04 | .85 |

TABLE 12.

TC-222
Metal Ceramic
EM=Philips Type "B"

| <u>Emitter Br.</u> <u>°C</u> | <u>Cesium T.</u> <u>°C</u> | <u>Collector T.</u> <u>°C</u> | <u>Current</u> <u>Amps</u> | <u>Voltage</u> <u>Volts</u> | <u>Power</u> <u>Watts</u> | <u>Power Density</u> <u>Watts/cm²</u> |
|---------------------------------|-------------------------------|----------------------------------|-------------------------------|--------------------------------|------------------------------|---|
| 1150 | 173 | 255 | 3.0 | .25 | .75 | .59 |
| 1175 | 173 | 260 | 5.1 | .23 | 1.17 | .93 |
| 1190 | 173 | 255 | 6.35 | .22 | 1.40 | 1.11 |
| 1220 | 173 | 260 | 6.3 | .31 | 1.95 | 1.55 |

TABLE 13.

| CELL # | GEOMETRY | EMITTER TYPE | EMITTER AREA CM ² | EMITTER BR. °C | CESIUM TEMP. °C | POWER DENSITY WATTS/CM ² |
|--------|------------------------------|-----------------------------|---------------------------------|-------------------|--------------------|--|
| TC-173 | Cylindrical | *S-70 | 1.18 | 1150 | 200 | 0.24 |
| TC-178 | Cylindrical | S-70 | 1.18 | 1100 | 240 | 0.60 |
| TC-195 | Cylindrical | Oxide** Triple Carbonate | 1.18 | | | |
| TC-196 | Planar | S-85 | 0.07 | 1150 | 225 | 5.50 |
| TC-EC3 | Cylindrical | S-85 | 1.18 | 1150 | 200 | 0.84 |
| TC-222 | Metal Ceramic Opposed Cup | Phillips Type "B" | 1.27 | 1190 | 173 | 1.10 |
| TC-225 | Metal Ceramic Opposed Cup | S-85 | 1.27 | 1180 | 170 | 0.86 |
| TC-229 | Metal Ceramic Opposed Cup | S-85 | 1.27 | 1150 | 168 | 0.99 |
| TC-235 | Cylindrical | S-80 | 1.18 | | | |
| TC-240 | Cylindrical | S-80 | 1.18 | 1190 | 220 | 0.71 |
| TC-241 | Cylindrical | S-85 | 1.18 | 1150 | 200 | 1.22 |
| TC-242 | Cylindrical | S-70 | 1.18 | 1100 | 210 | 1.02 |
| TC-243 | Cylindrical | S-70 | 1.18 | 1150 | 200 | 1.08 |

*S-Designates Semicon Types

**Sylvania Type

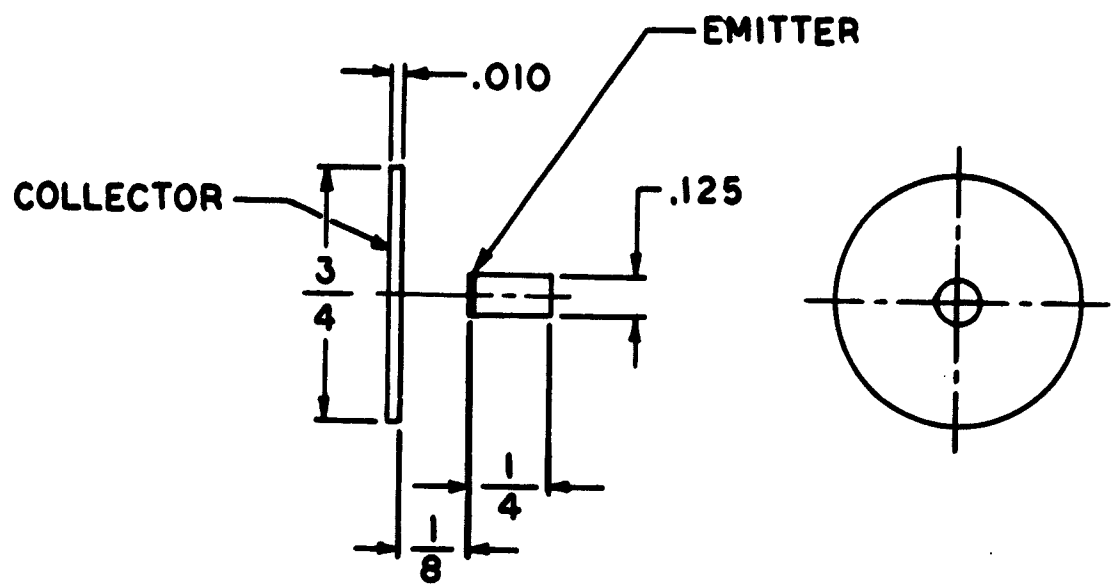

FIGURE 1

PLANAR GEOMETRY

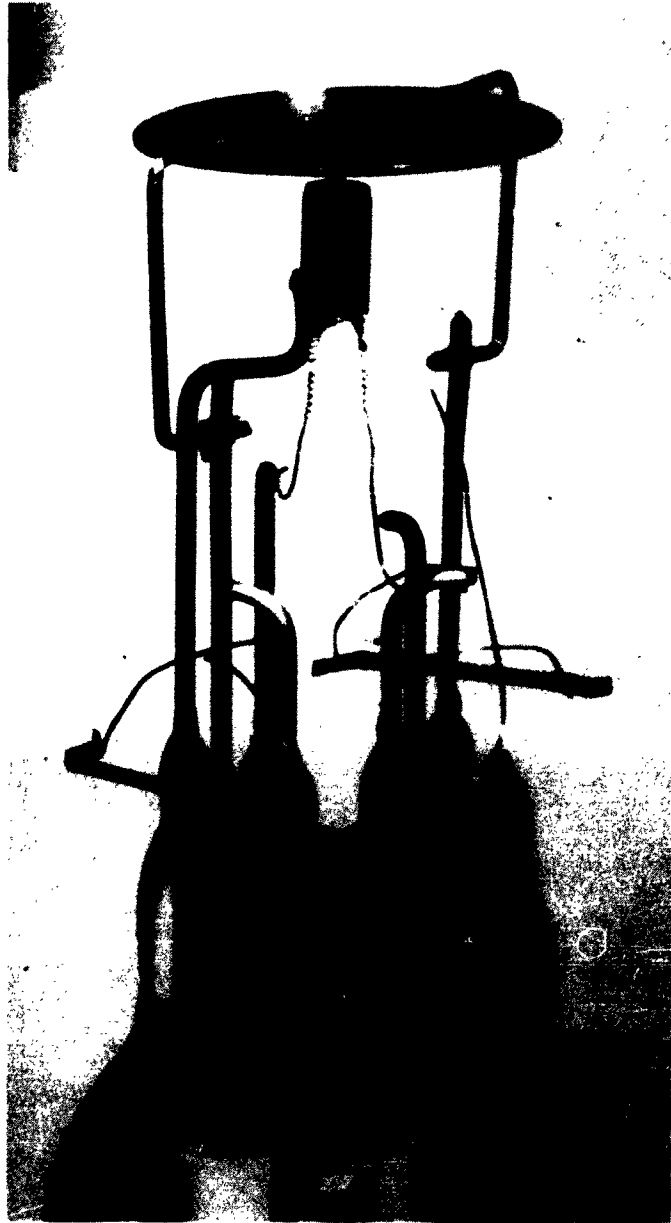

FIGURE 2 PLANAR GEOMETRY ASSEMBLY

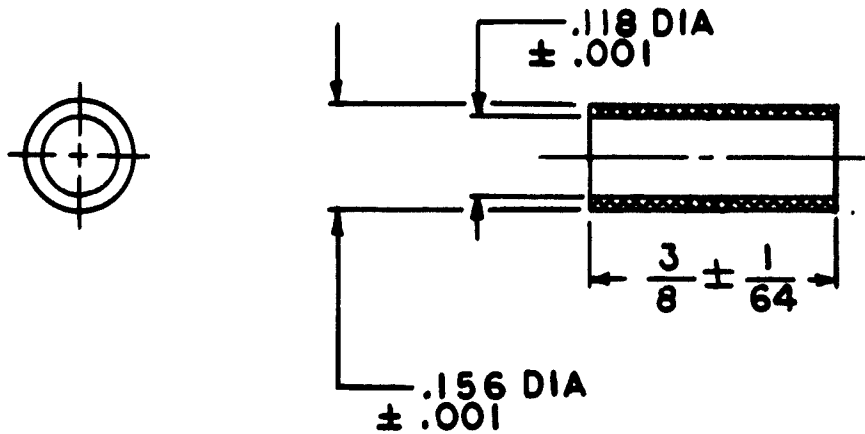

FIGURE 3A CYLINDRICAL EMITTER

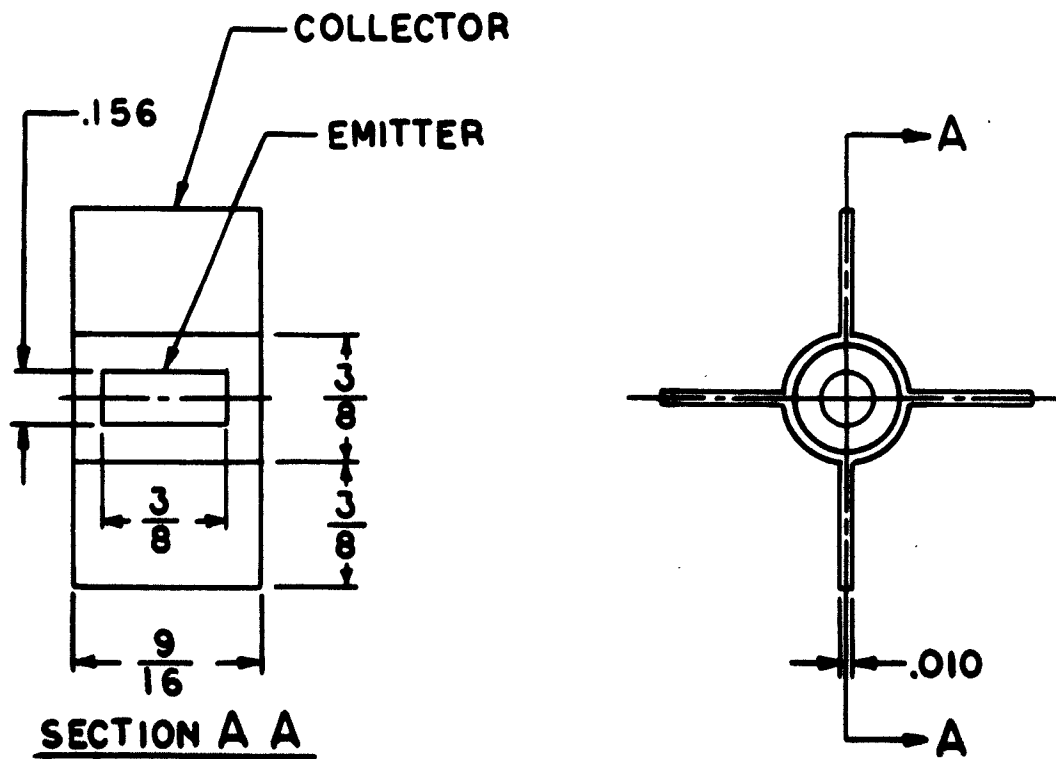

FIGURE 3B CYLINDRICAL GEOMETRY

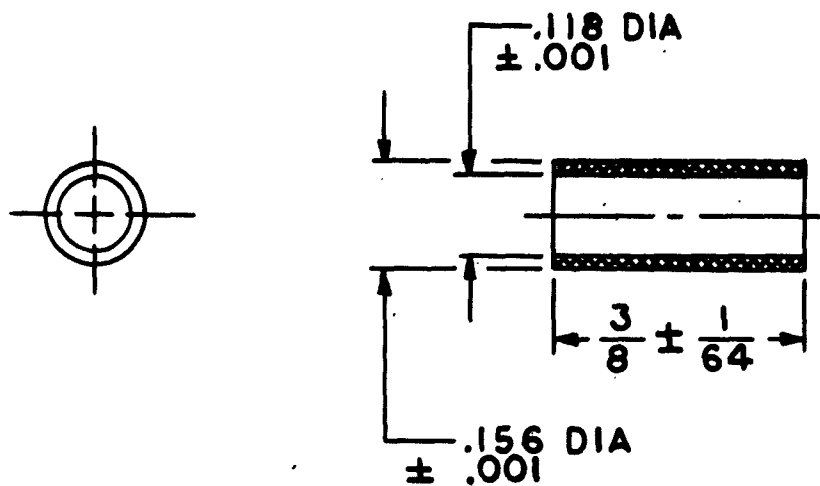

FIGURE 4A CYLINDRICAL EMITTER

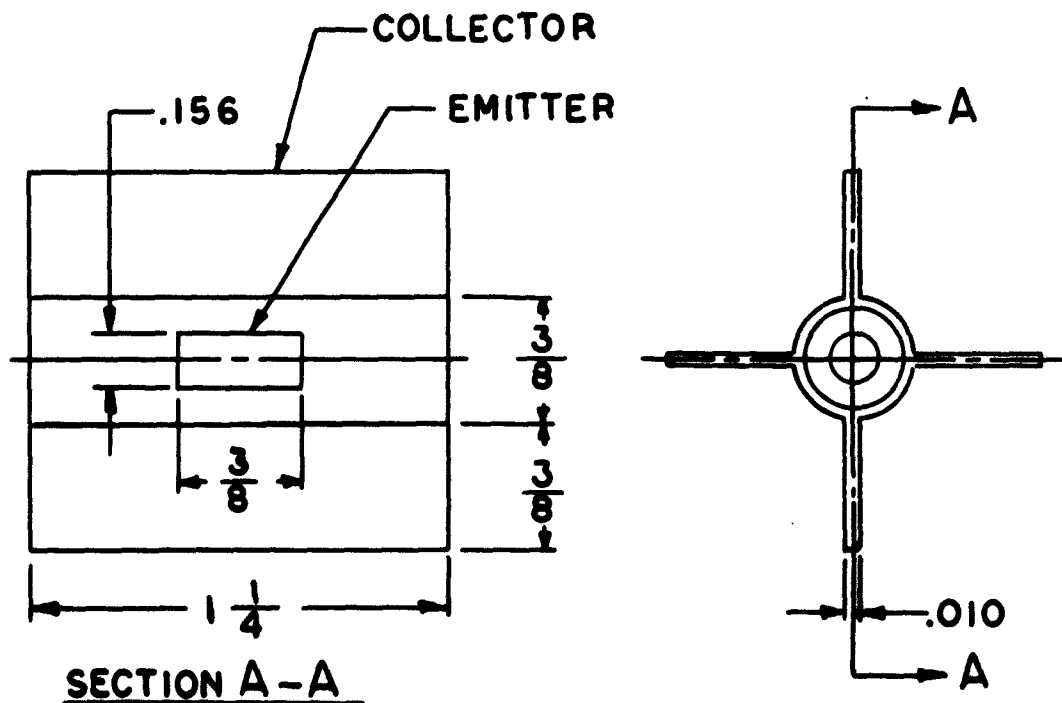

FIGURE 4B CYLINDRICAL GEOMETRY

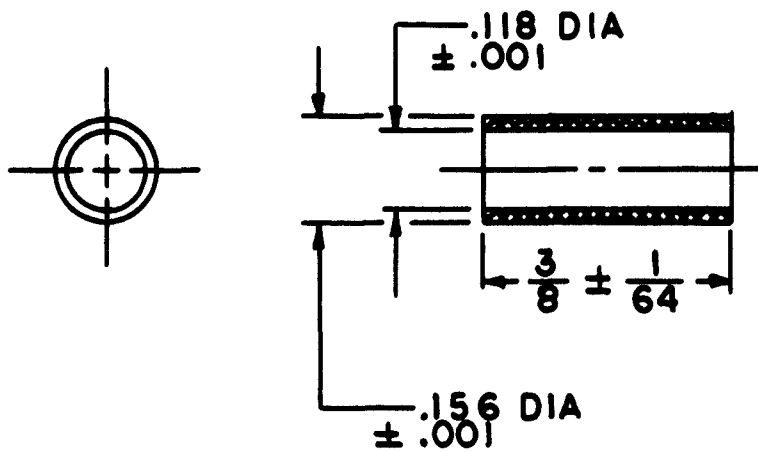

FIGURE 5 A CYLINDRICAL EMITTER

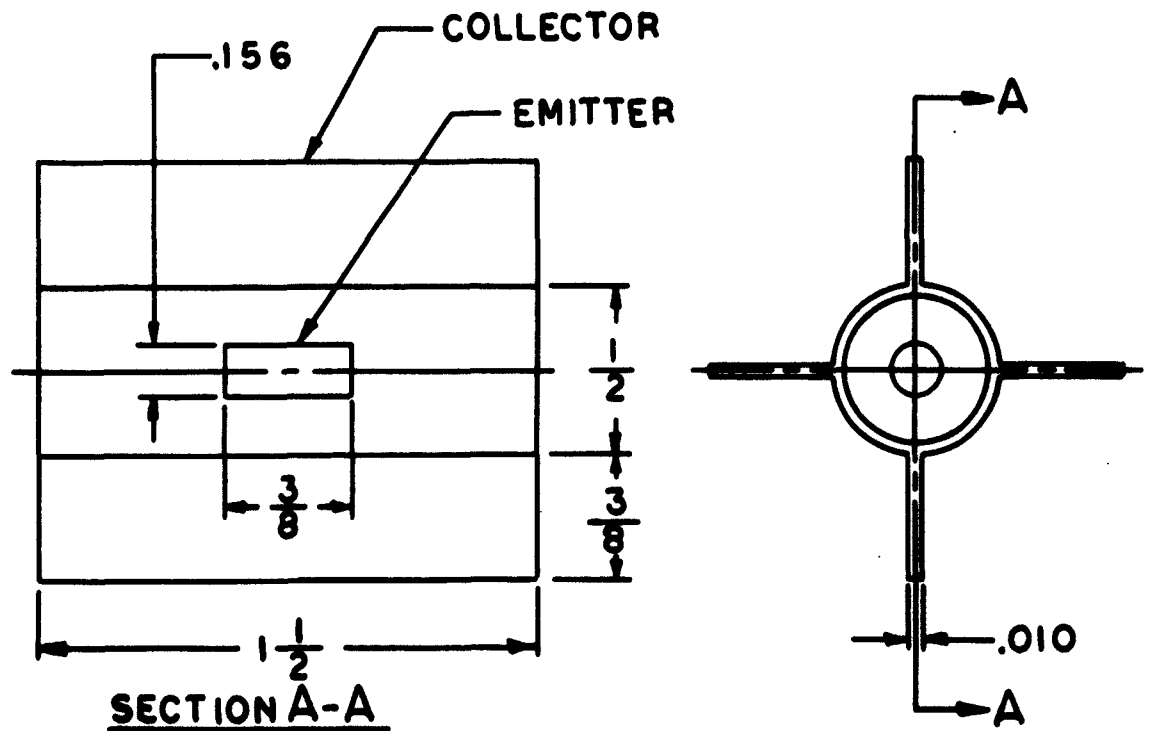

FIGURE 5 B CYLINDRICAL GEOMETRY

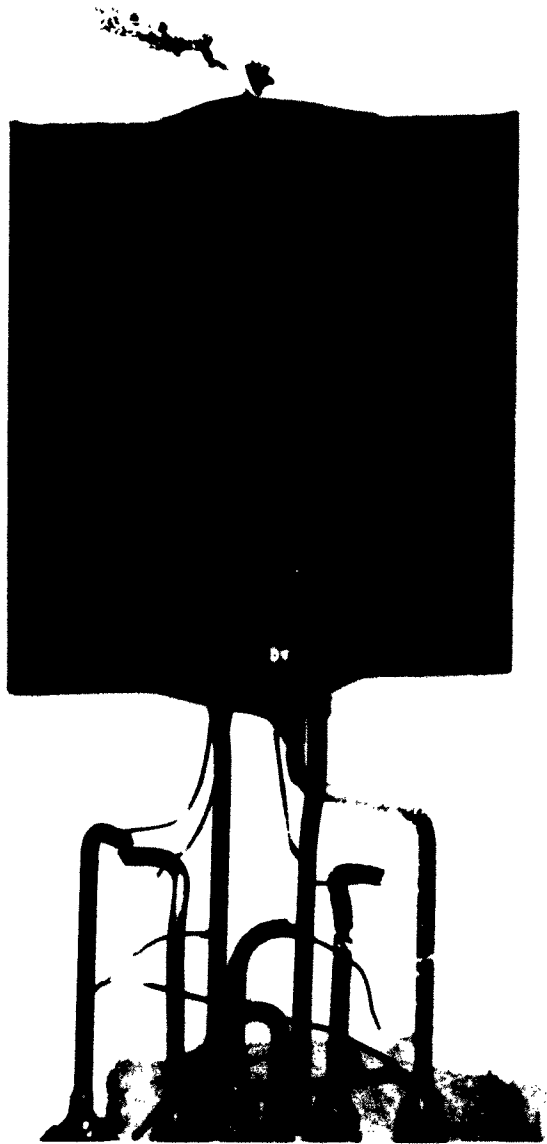

FIGURE 6 CYLINDRICAL GEOMETRY ASSEMBLY

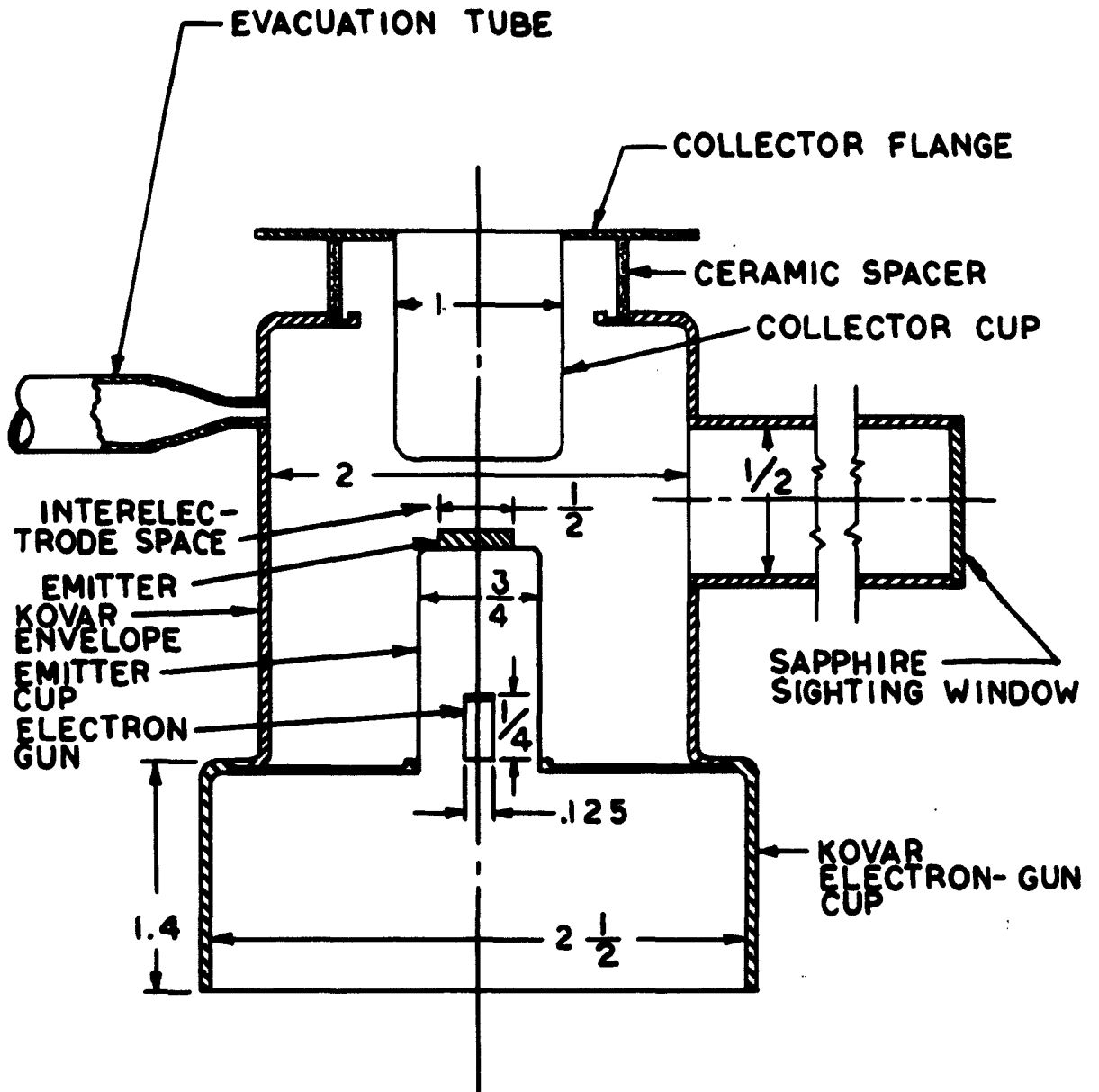

FIGURE 7 OPPOSED CUP METAL-CERAMIC GEOMETRY



FIGURE 8 OPPOSED CUP METAL CERAMIC ASSEMBLY

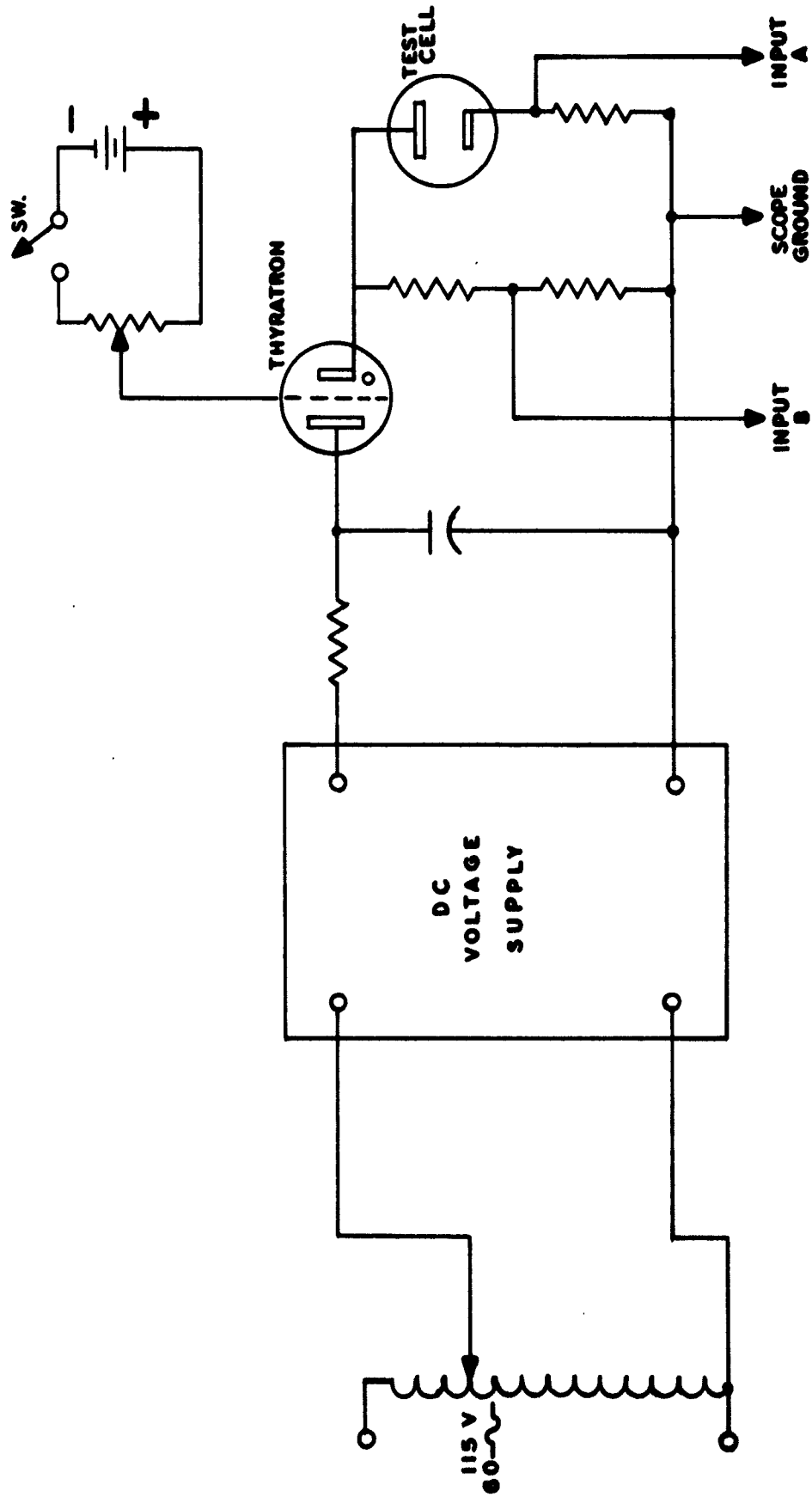

FIGURE 9 CIRCUIT DIAGRAM FOR MEASURING VACUUM EMISSION

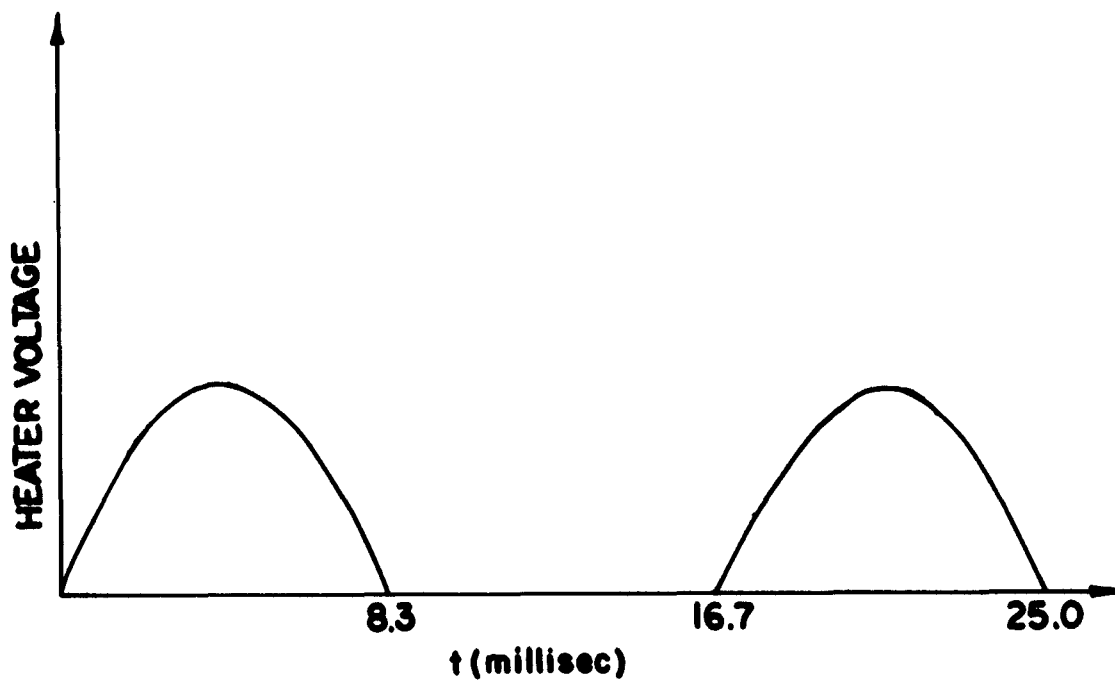
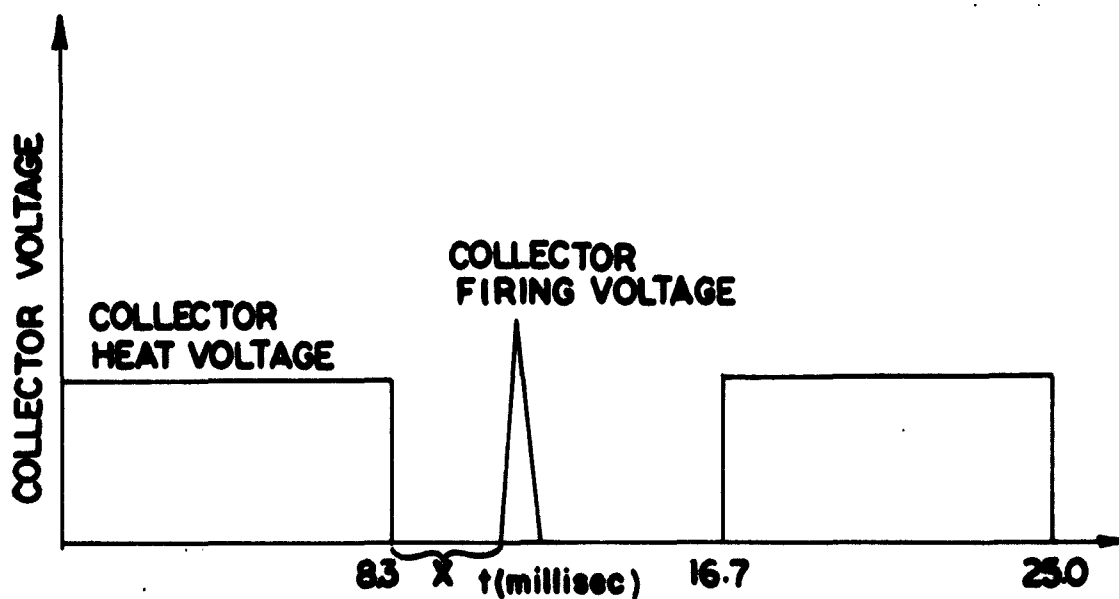

FIGURE 10A HEATER VOLTAGE VS TIME



NOTE: X IS A VARIABLE DELAY WITH A RANGE FROM 0 TO 8.3MS

FIGURE 10B COLLECTOR VOLTAGE VS TIME

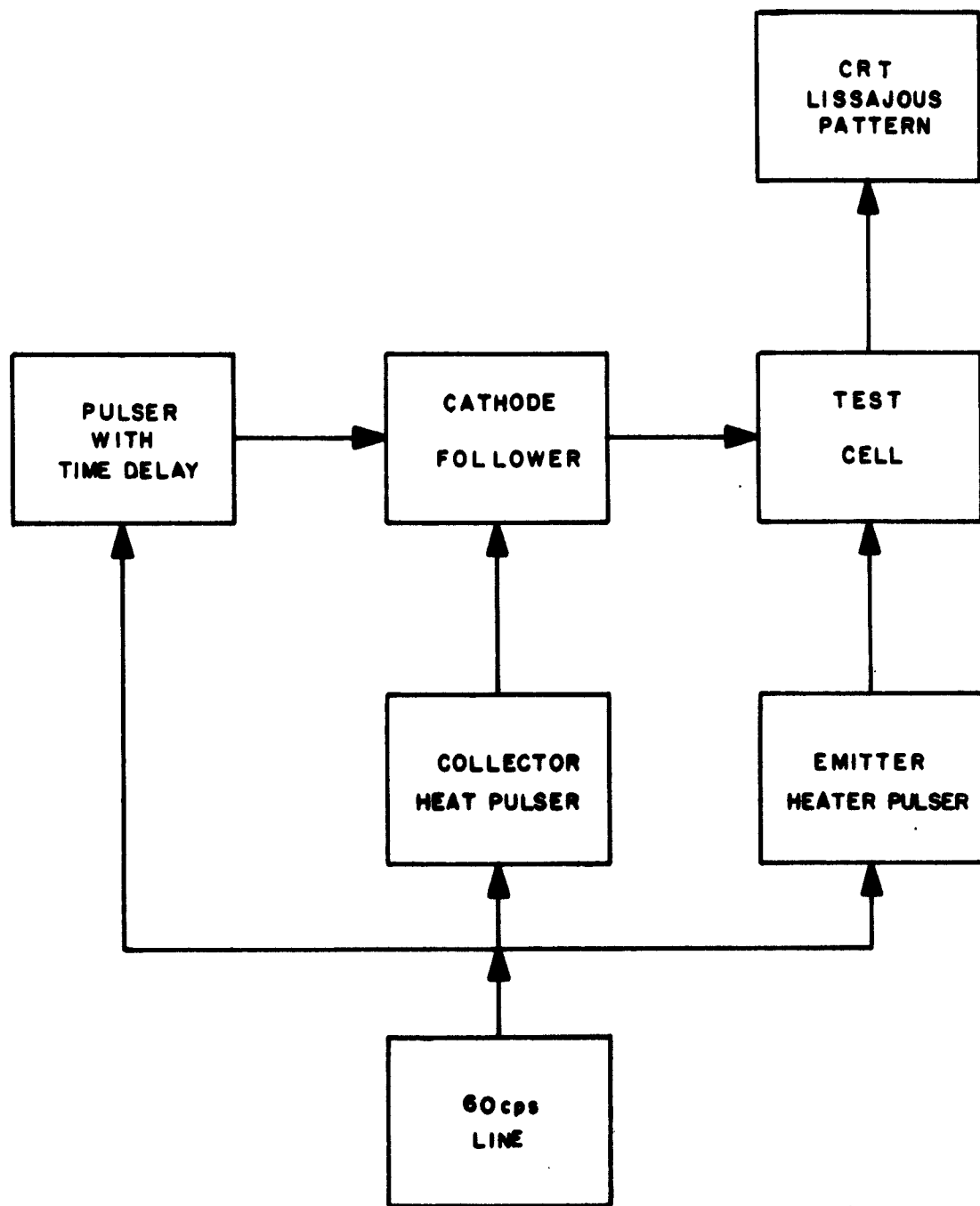

FIGURE 11 SIMPLIFIED BLOCK DIAGRAM OF THERMIONIC CELL EVALUATION CIRCUITRY

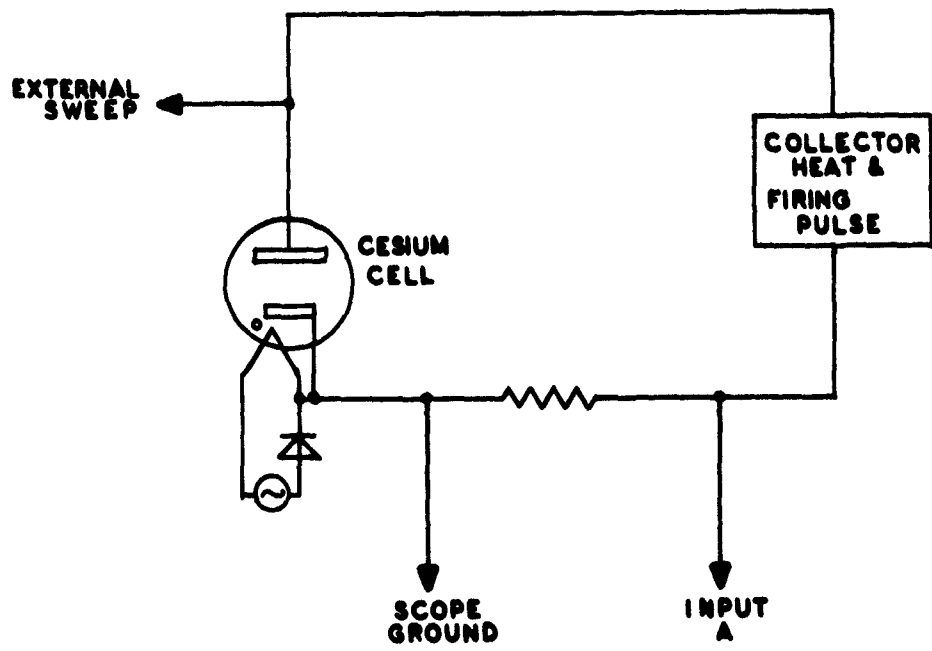

FIGURE 12 CIRCUIT DIAGRAM FOR I vs V PULSE TESTING

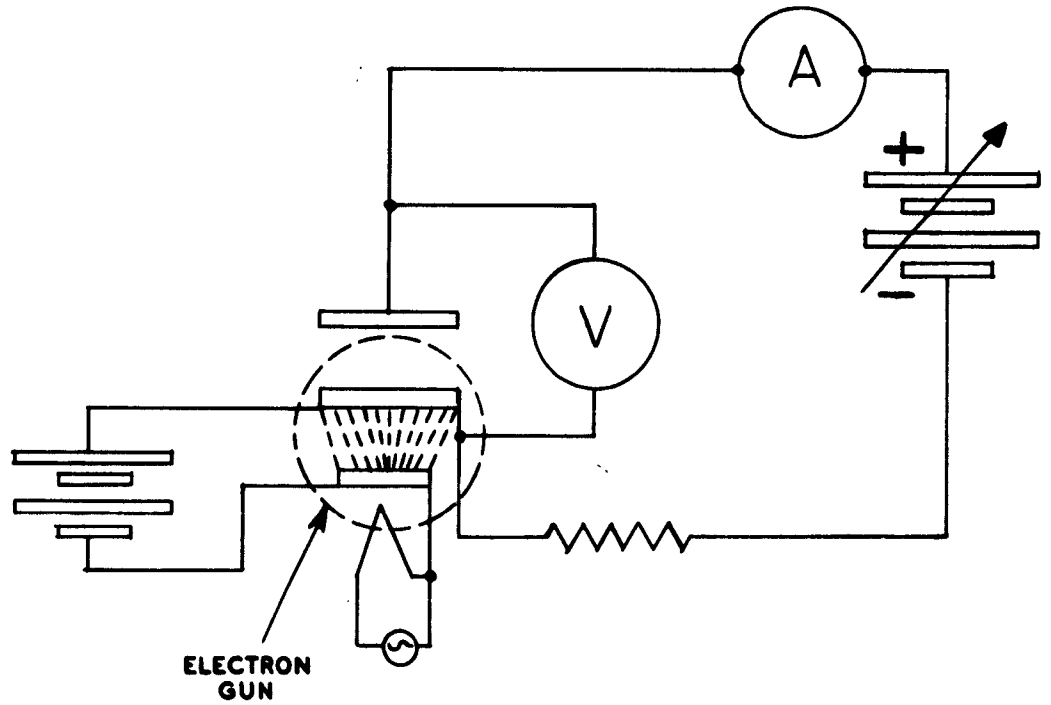
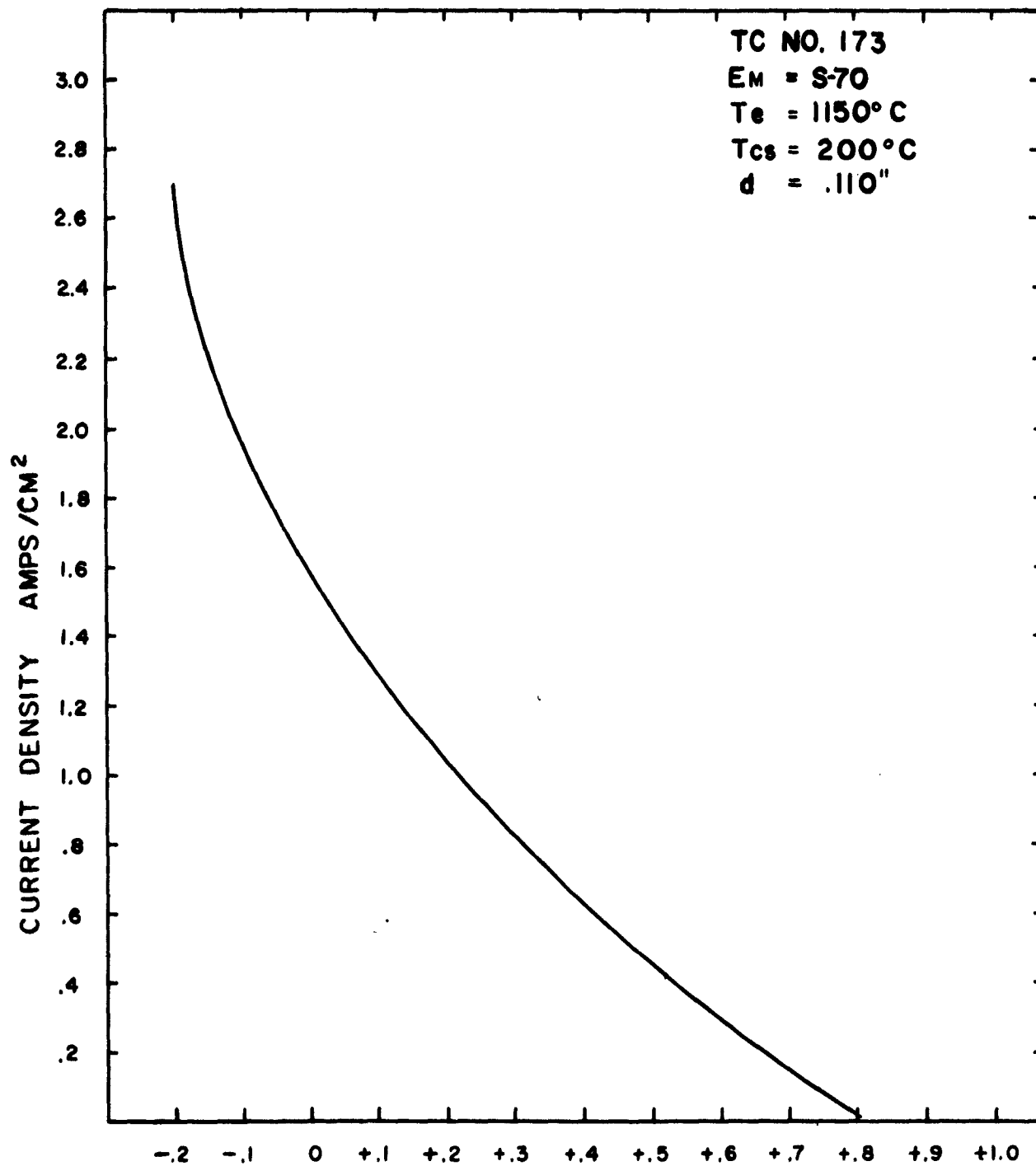

FIGURE 13 CIRCUIT DIAGRAM FOR DC TESTING OF CELL



OUTPUT VOLTAGE-VOLTS

FIGURE 14 CURRENT DENSITY VS OUTPUT VOLTAGE

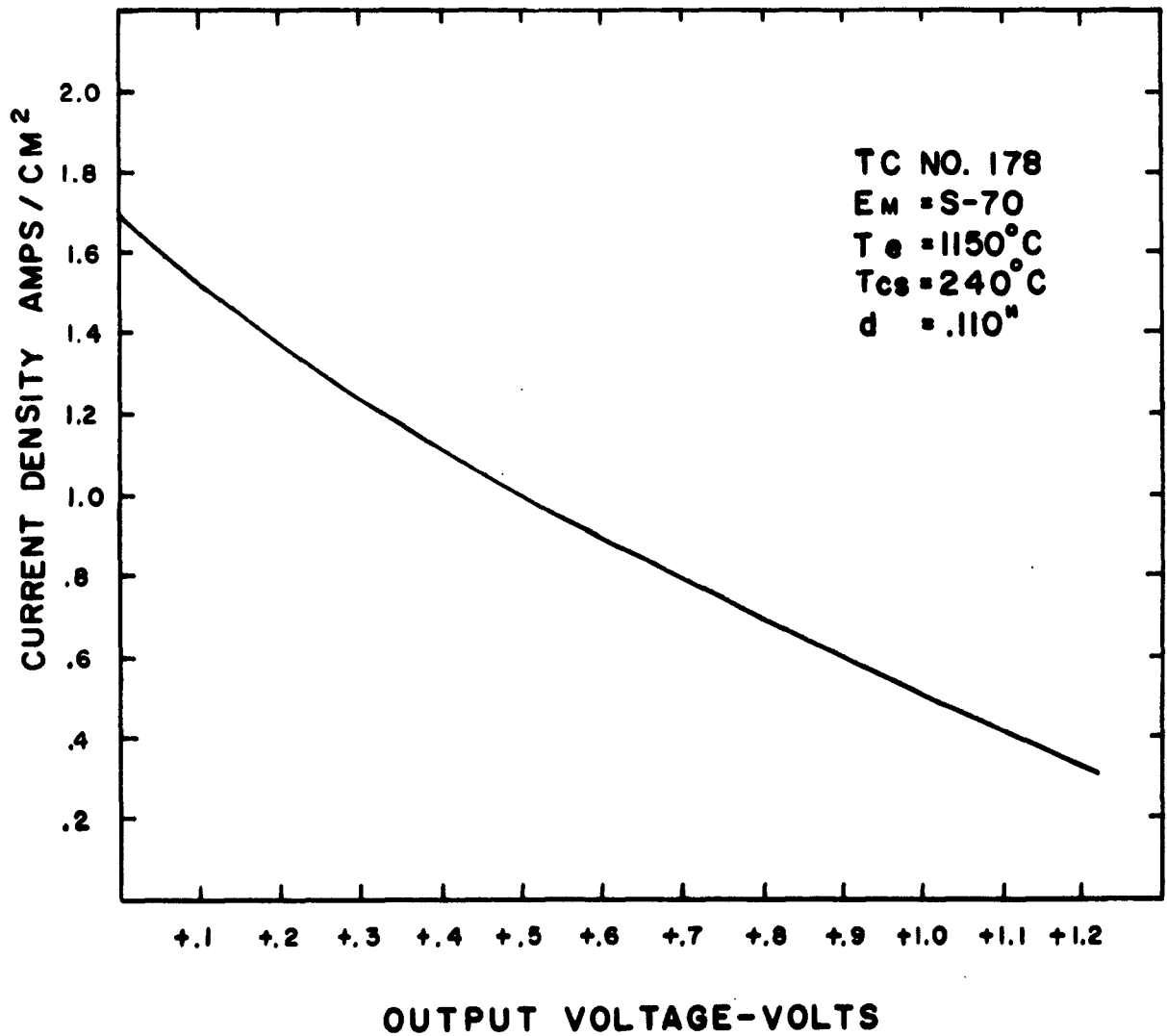

FIGURE 15 CURRENT DENSITY VS OUTPUT VOLTAGE

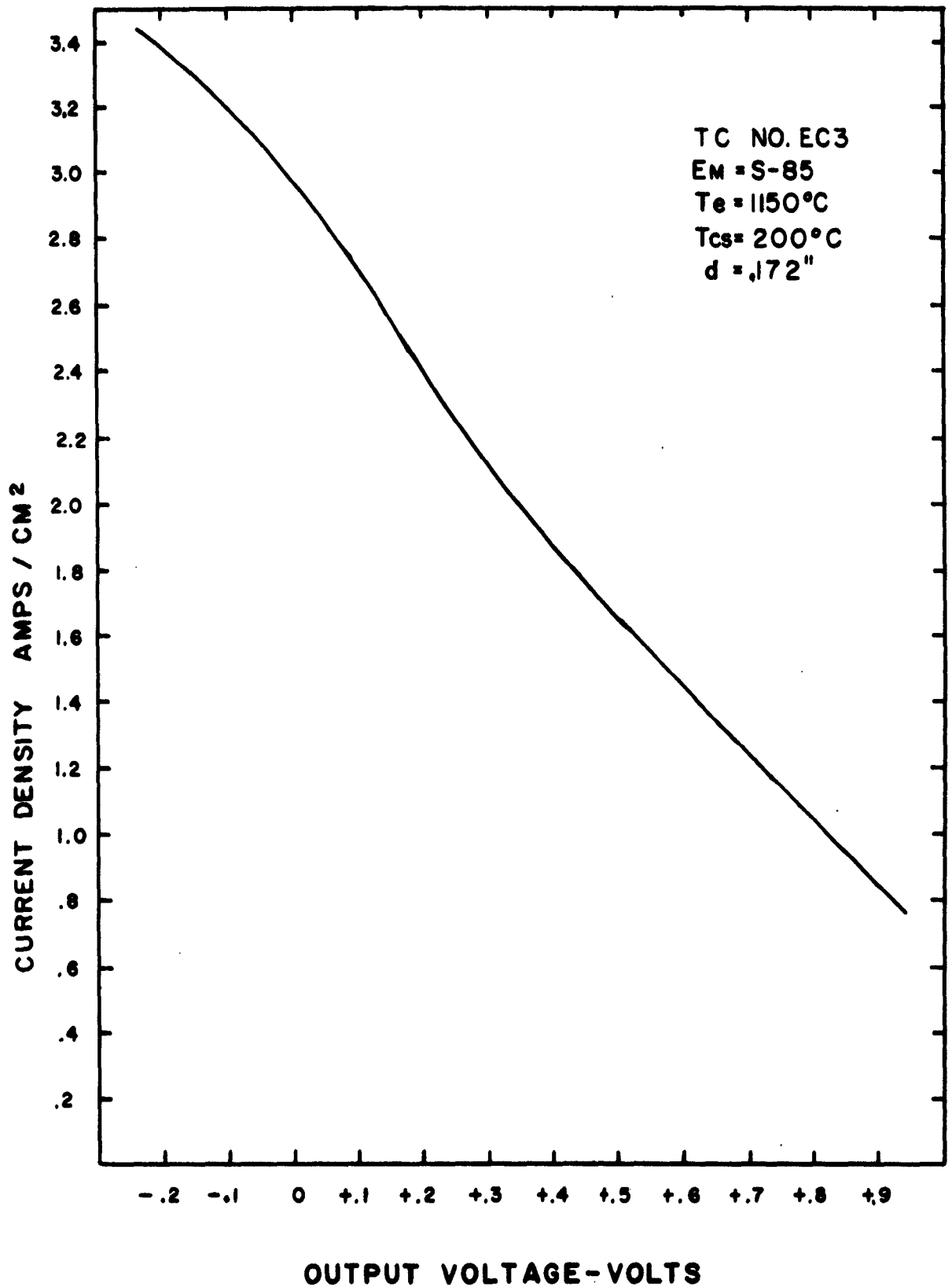
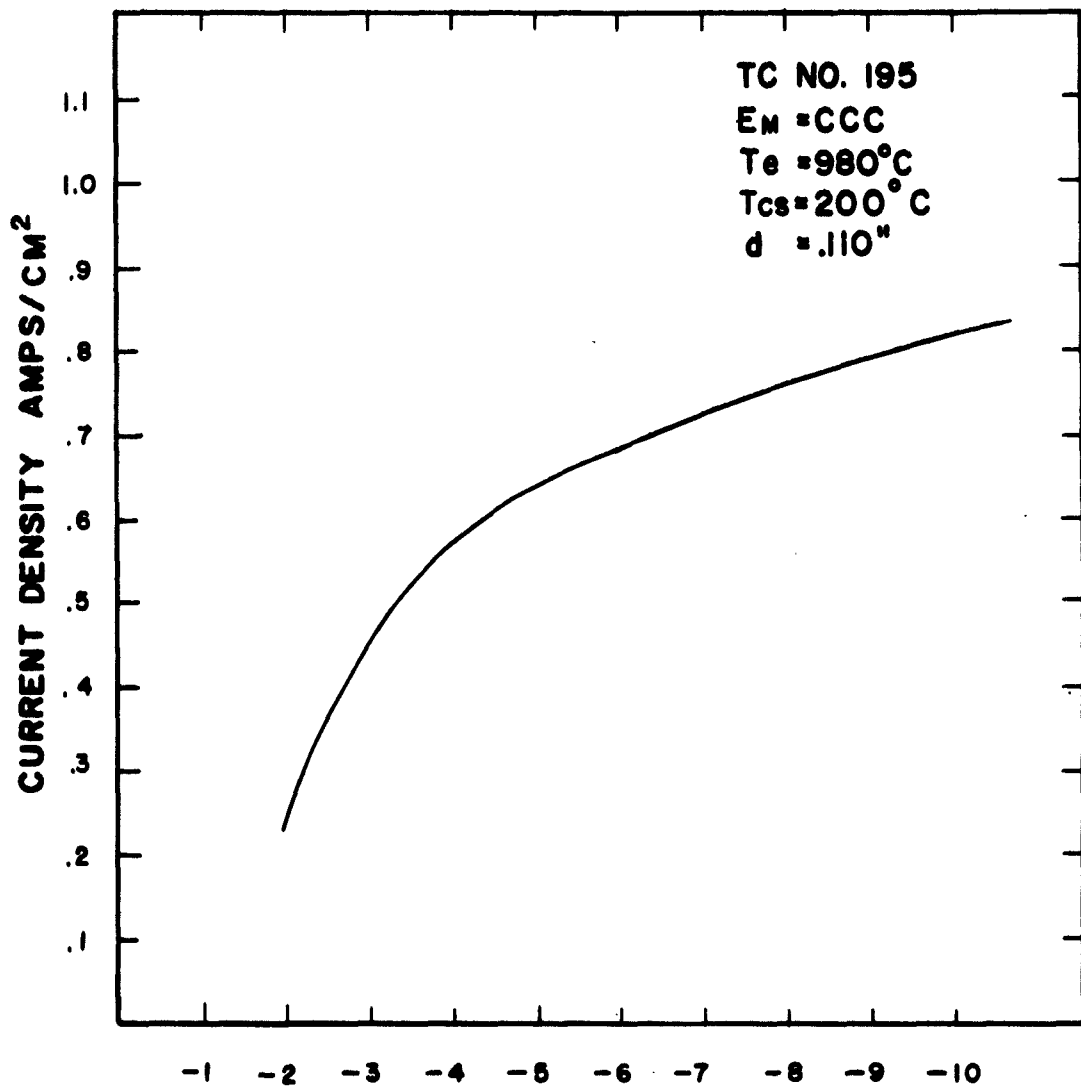
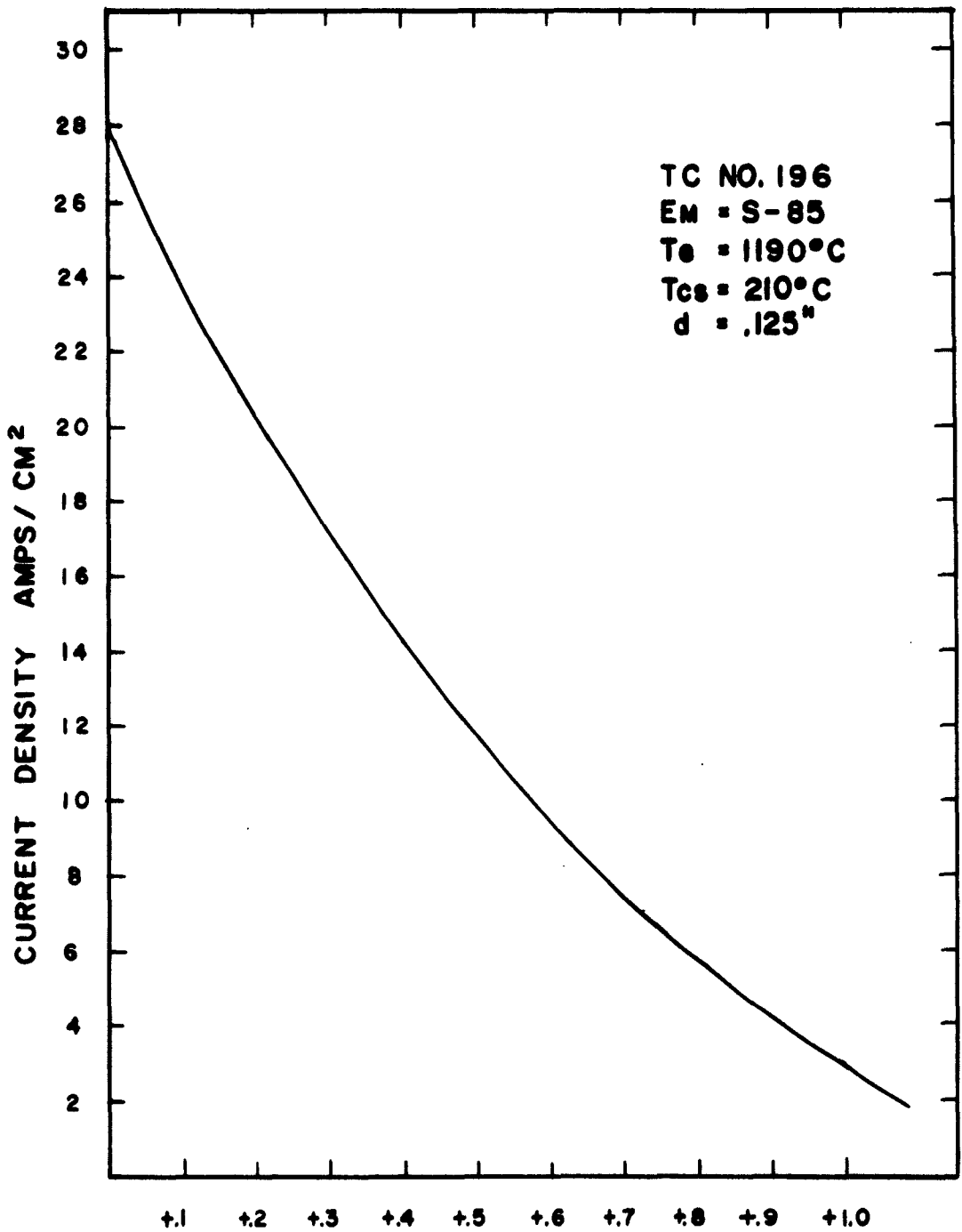

FIGURE 16 CURRENT DENSITY VS OUTPUT VOLTAGE



OUTPUT VOLTAGE - VOLTS

FIGURE 17 CURRENT DENSITY VS OUTPUT VOLTAGE



OUTPUT VOLTAGE-VOLTS

FIGURE 18 CURRENT DENSITY VS OUTPUT VOLTAGE

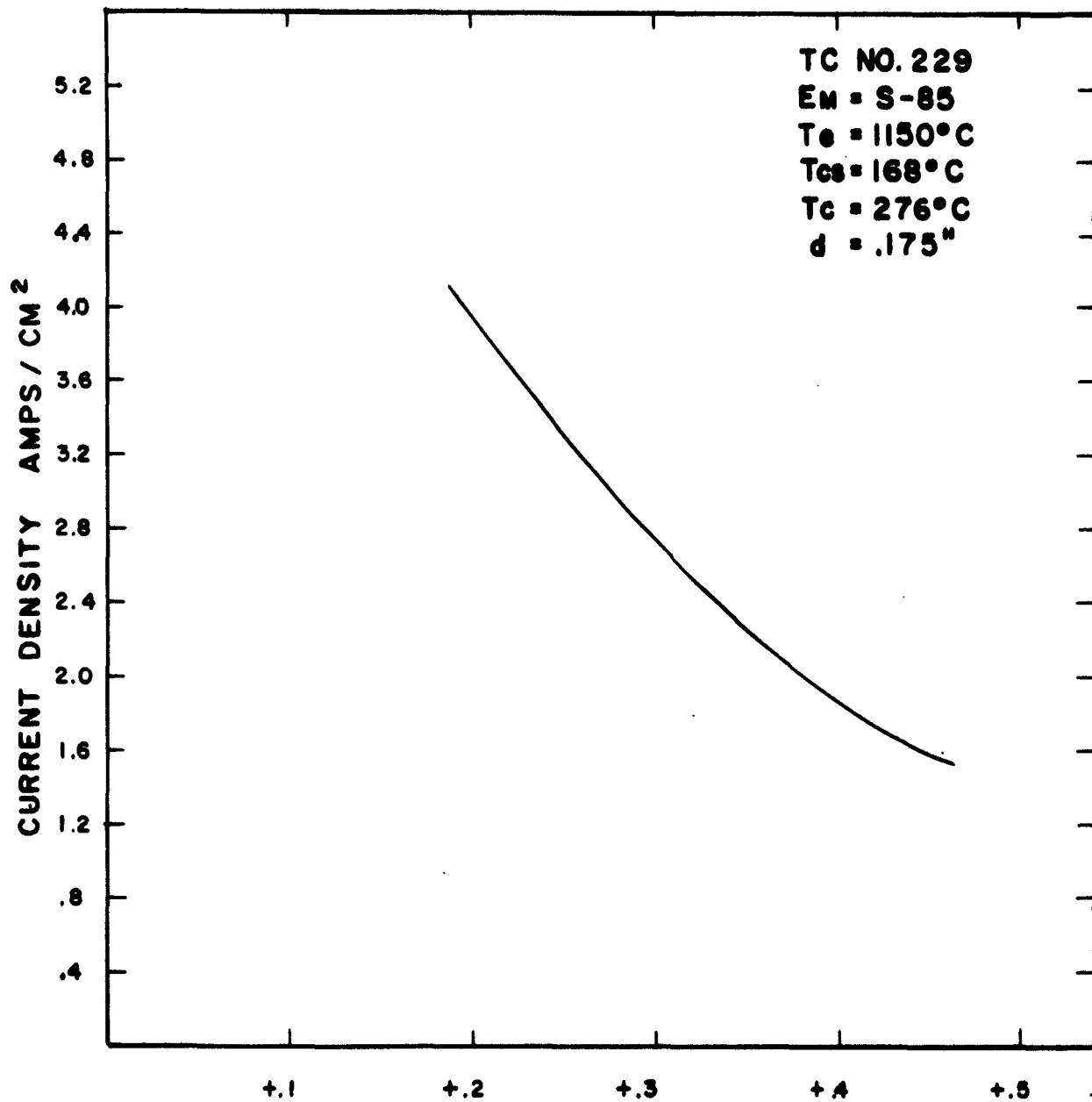

OUTPUT VOLTAGE - VOLTS

FIGURE 19 CURRENT DENSITY VS OUTPUT VOLTAGE

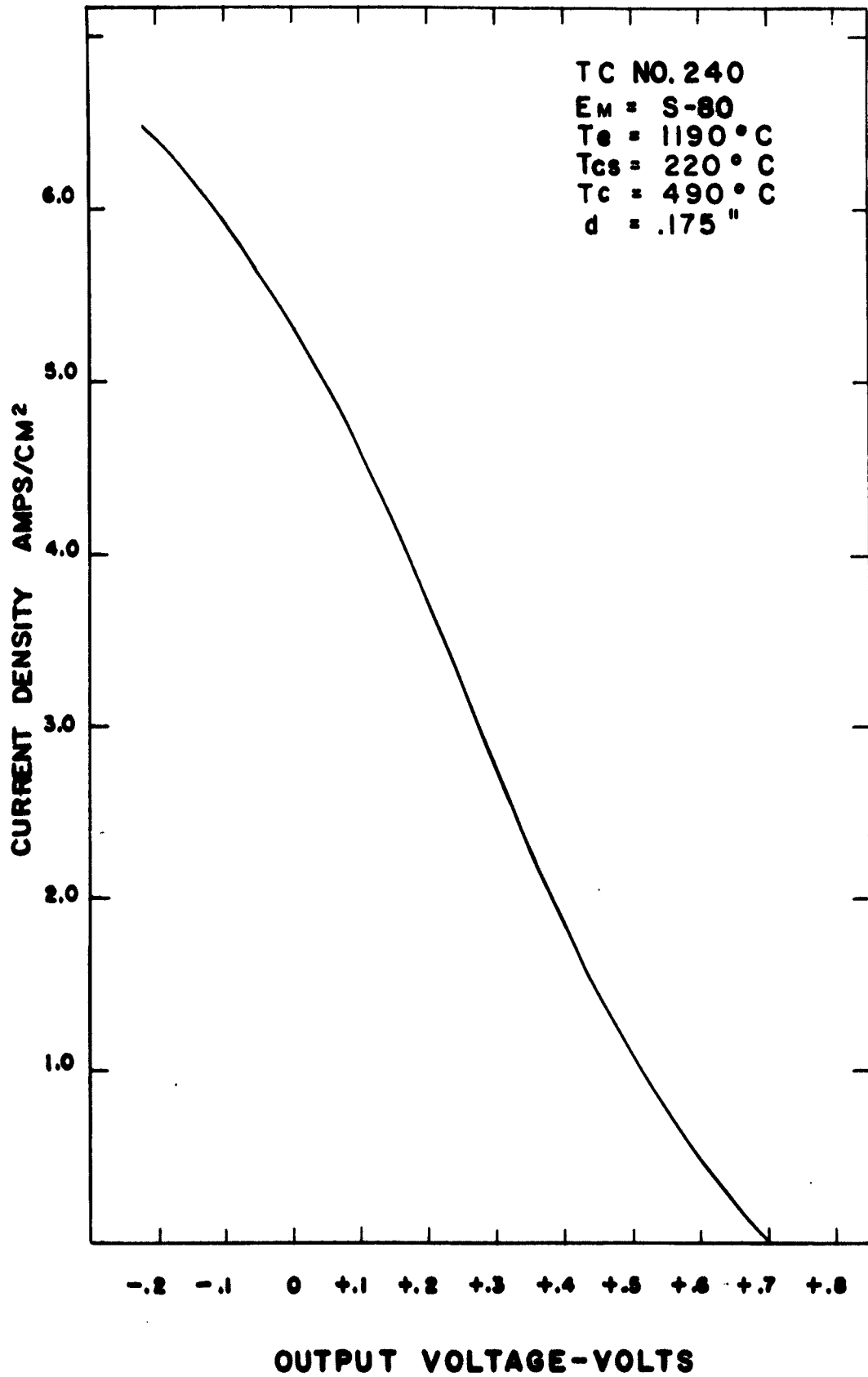

FIGURE 20 CURRENT DENSITY VS OUTPUT VOLTAGE

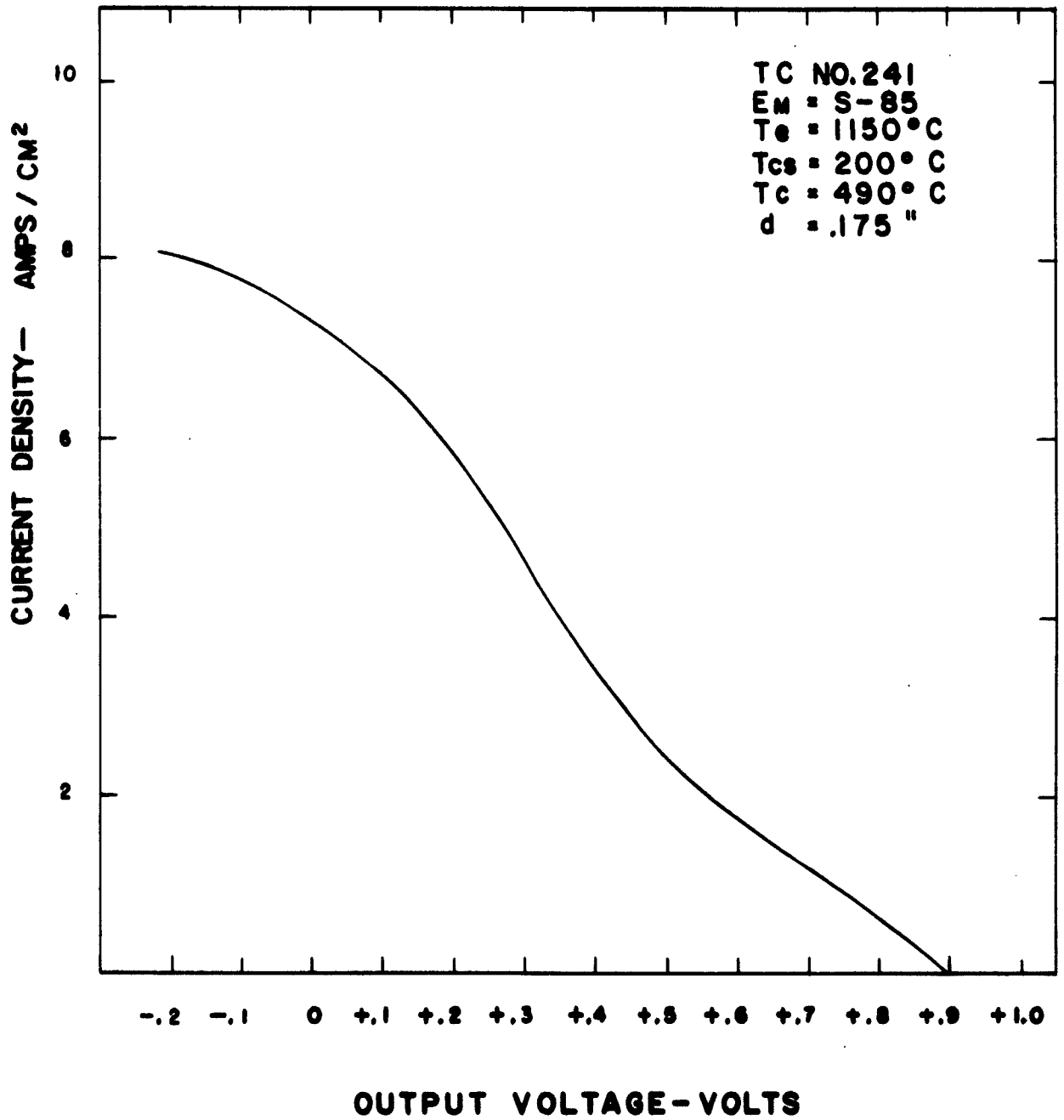
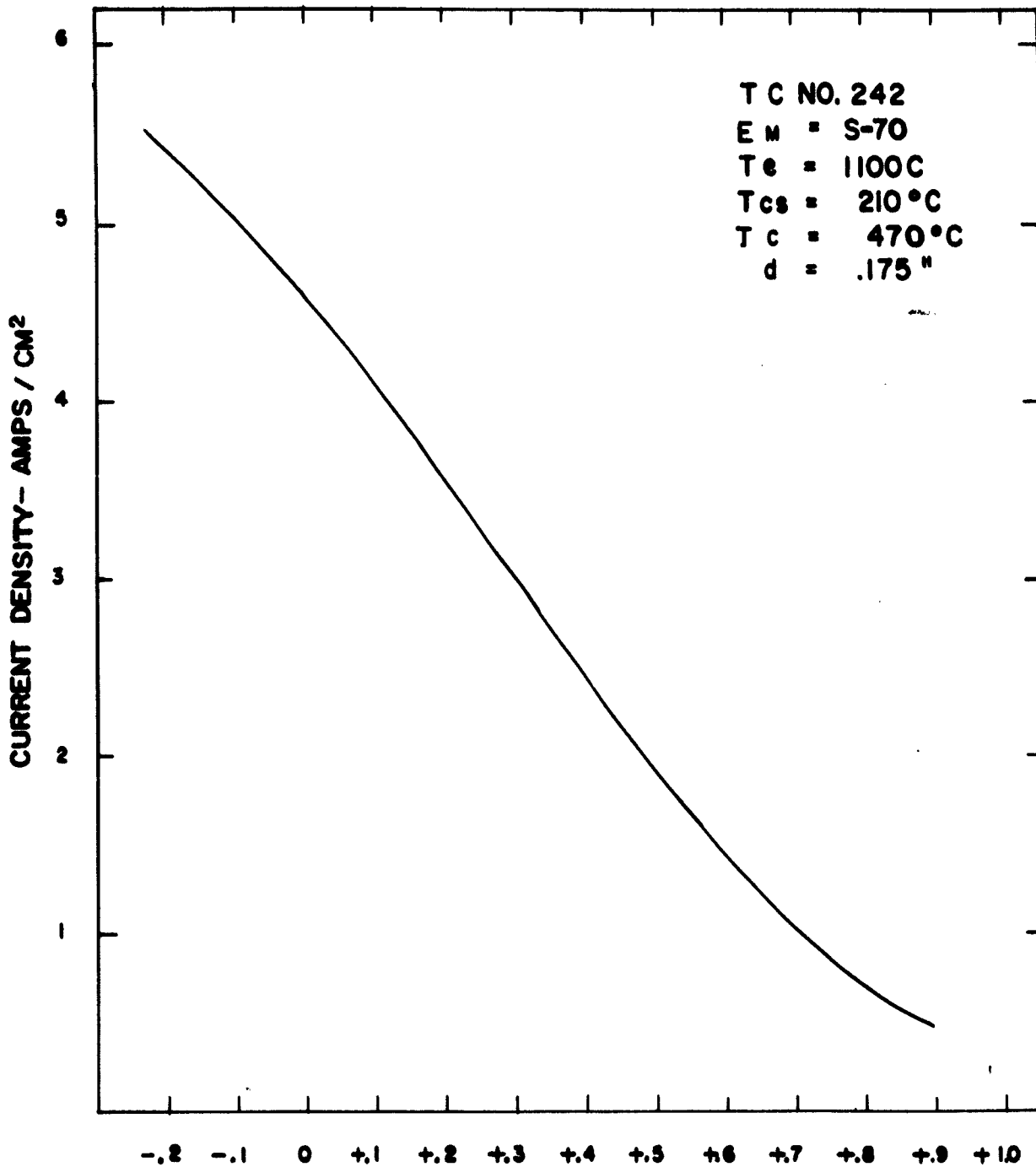
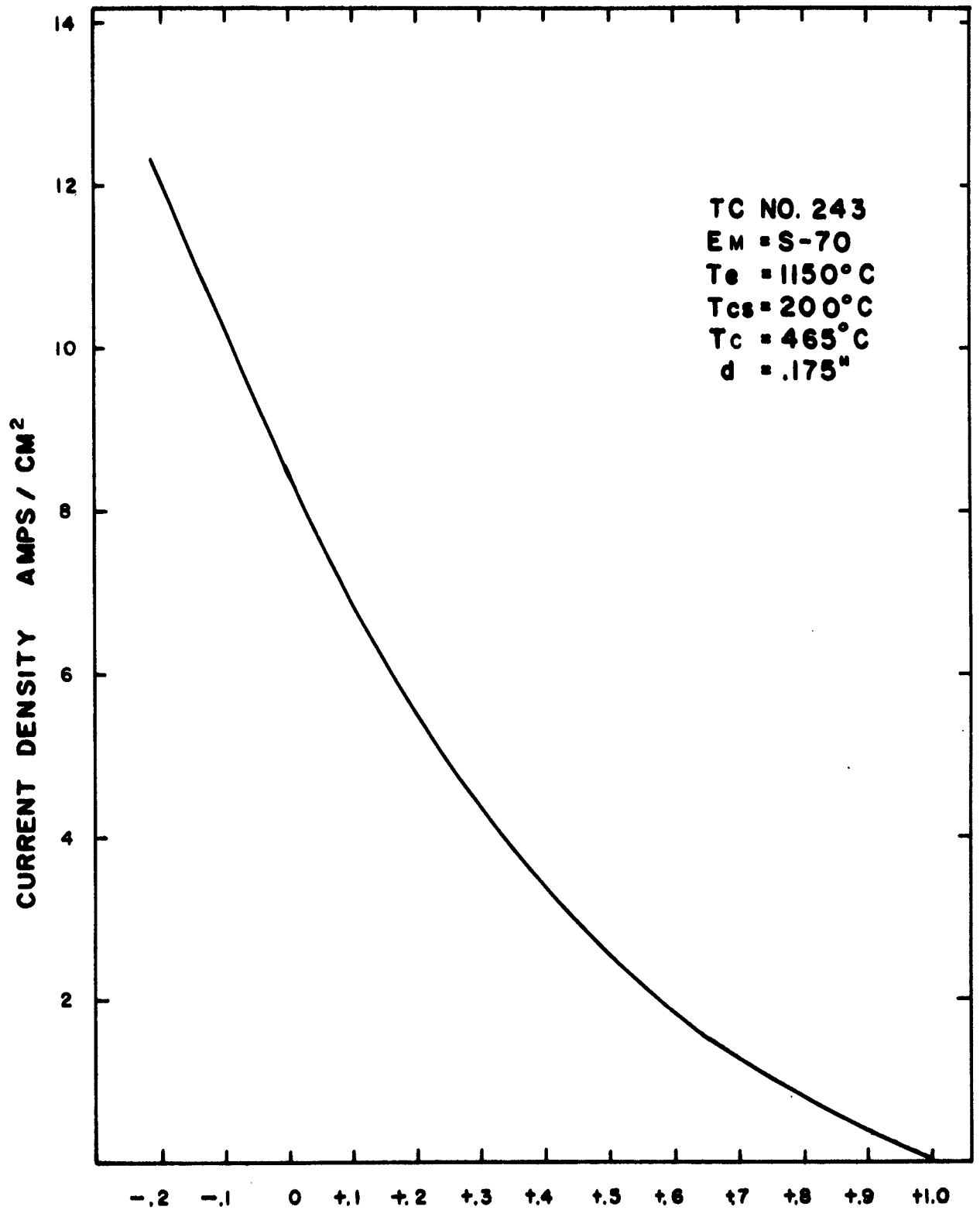

FIGURE 21 CURRENT DENSITY VS OUTPUT VOLTAGE



OUTPUT VOLTAGE-VOLTS
FIGURE 22 CURRENT DENSITY VS OUTPUT VOLTAGE



OUTPUT VOLTAGE-VOLTS

FIGURE 23 CURRENT DENSITY VS OUTPUT VOLTAGE

DISTRIBUTION LIST

| | <u>No. copies</u> |
|--|-------------------|
| Office of Naval Research Power Branch (Code 429) Department of the Navy Washington 25, D.C. | 4 |
| Cognizant ONR Area Branch Office | 1 |
| U. S. Naval Research Laboratory Technical Information Division Washington 25, D. C. | 6 |
| Commanding Officer Office of Naval Research Branch Office Box 39 Navy #100 Fleet Post Office New York, New York | 2 |
| Office of Technical Services Department of Commerce Washington 25, D. C. | 1 |
| Armed Services Technical Information Agency Arlington Hall Station Arlington 12, Virginia | 10 |
| National Aeronautics and Space Administration 1520 H. Street, N. W. Washington 25, D. C. Attn: James J. Lynch | 1 |
| National Aeronautics and Space Administration Lewis Research Center 2100 Brookpark Road Cleveland 35, Ohio Attn: Frank Rom Roland Brietwieser Bernard Lubarsky | 1 1 1 |
| Chief of Naval Operations (OP-07G) Department of the Navy Washington 25, D. C. | 1 |
| Commandant, U.S. Marine Corps Code CSY-3 Headquarters, Marine Corps Washington 25, D. C. | 1 |

DISTRIBUTION LIST (Cont'd)

| | <u>No. copies</u> |
|--|-------------------|
| Chief, Bureau of Ships Department of the Navy Washington 25, D. C. | |
| Attn: Code 342B | 2 |
| Code 1500 Mr. Wm. Hewitt | 1 |
| Code 456B, Mr. V. Gardner | 1 |
| Code 335 | 2 |
| U.S. Atomic Energy Commission Division of Reactor Development Washington 25, D. C. | |
| Attn: Auxiliary Power Branch | 1 |
| Direct Conversion Branch | 1 |
| Army Reactor and Water Systems Branch | 1 |
| U.S. Atomic Energy Commission San Francisco Operation Office 2111 Bancroft Way Berkeley 4, California | |
| Attn: Reactor Division | 1 |
| Aeronautical Systems Division ASRMFP-2 Wright Patterson Air Force Base Ohio | |
| | 1 |
| Air Force Cambridge Research Center (CRZAP) L. G. Hanscom Field Bedford, Massachusetts | |
| | 1 |
| Power Information Center University of Pennsylvania Moore School Building 200 South 33rd Street Philadelphia 4, Pennsylvania | |
| | 1 |
| Director of Special Projects (SP-001) Department of the Navy Washington 25, D. C. | |
| | 10 |
| Los Alamos Scientific Laboratory P.O. Box 1663 Los Alamos, New Mexico Attn: Dr. George M. Grover | |
| | 1 |

DISTRIBUTION LIST (Cont'd)

| | <u>No. copies</u> |
|--|-------------------|
| Argonne National Laboratory 9700 South Cass Avenue Argonne, Illinois Attn: Aaron J. Ulrich | 1 |
| Director, Advanced Research Projects Agency The Pentagon Washington 25, D.C. Attn: Dr. John Huth | 1 |
| U. S. Army Signal R and D Laboratory Fort Monmouth, New Jersey Attn: Emil Kittl | 1 |
| Mr. A. F. Underwood Manager, General Motors Research Labs. 12 Mile and Mound Road Warren, Michigan Attn: Dr. F. Jamerson | 1 |
| Atomics International P.O. Box 309 Canoga Park, California Attn: Dr. R. C. Allen | 1 |
| General Atomic P. O. Box 608 San Diego 12, California Attn: Dr. W. Pidd | 1 |
| ARACON Laboratories Virginia Road Concord, Massachusetts Attn: Dr. S. Ruby | 1 |
| Ford Instrument Company 31-10 Thomson Avenue Long Island City, New York Attn: T. Jarvis | 1 |
| Armour Research Foundation 10 W. 35th Street Chicago 16, Illinois Attn: Dr. D. W. Levinson | 1 |
| Jet Propulsion Laboratory California Institute of Technology 4800 Oak Grove Drive Pasadena, California | 1 |

DISTRIBUTION LIST (Cont'd)

| | <u>No. copies</u> |
|---|-------------------|
| RCA Laboratories David Sarnoff Research Center Princeton, New Jersey Attn: Dr. Paul Rappaport | 1 |
| The Martin Corporation Baltimore 3, Maryland Attn: Dr. M. Talaat | 1 |
| Thermo Electron Engineering Corporation 85 First Avenue Waltham 54, Massachusetts Attn: Dr. George Hatsopoulos | 1 |
| Hughes Research Laboratories 3011 Malibu Canyon Road Malibu, California Attn: Dr. R.C. Knechtli | 1 |
| Thomson Ramo Wooldridge, Inc. 7209 Platt Avenue Cleveland 4, Ohio Attn: Wm. J. Leovic | 1 |
| General Electric Research Laboratory Schenectady, New York Attn: Dr. V. C. Wilson | 1 |
| The Marquardt Corporation ASTRO Division 16555 Saticoy Street Van Nuys, California Attn: A. N. Thomas | 1 |
| Texas Instruments, Inc. P.O. Box 5474 Dallas 22, Texas Attn: Dr. R. A. Chapman | 1 |
| University of Denver Colorado Seminary Denver Research Institute Denver 10, Colorado Attn: Dr. Charles B. Magee | 1 |

DISTRIBUTION LIST (Cont'd)

| | <u>No. copies</u> |
|--|-------------------|
| Radio Corp. of America Electron Tube Division Lancaster, Pennsylvania Attn: F. G. Block | 1 |
| Electro Optical Systems Inc. 125 N. Kinedo Avenue Pasadena, California Attn: A. Jensen | 1 |
| General Electric Company P.O. Box 846 Atomic Product Division Vallecitos Laboratory Pleasanton, California Attn: Robert Scott | 1 |
| General Electric Company Power Tube Division 1 River Road Schenectady 5, New York Attn: Mr. Wm. Miller | 1 |
| Consolidated Controls Corporation Bethel, Connecticut Attn: Mr. David Mende | 1 |
| Institute for Defense Analysis 1666 Connecticut Avenue, N.W. Washington, D. C. Attn: Mr. Robert Hamilton | 1 |

| | | | |
|--|---|---|---|
| <p>Ford Instrument Company, Division of Sperry Rand Corporation, 31-10 Thomson Avenue, Long Island City 1, N. Y. EMITTER MATERIALS STUDY THERMIONIC ENERGY CONVERTERS, by M. Silverberg and L. L. Haring. 31 December 1962, 73 pp. illus. (Task NR 391-429) (Final Technical Report); (Contract Nonr 3696(00))</p> <p>Unclassified Report</p> <p>An experimental program was conducted on selected emitter materials to determine their potential for use in low temperature thermionic energy converters. One oxide emitter and four different dispenser types were evaluated in parallel plate and cylindrical geometry in both glass and metal ceramic construction. With respect to power density the various dispenser emitter types showed suitable and reasonably similar performance. Performance degradation was reversed in some of these diodes and its mechanism explored and explained.</p> | <p>UNCLASSIFIED</p> <p>1. Direct energy conversion</p> <p>2. Thermionics</p> <p>I. M. Silverberg</p> <p>II. L. L. Haring</p> <p>III. Ford Instrument Company</p> <p>IV. Nonr 3696(00)</p> <p>UNCLASSIFIED</p> | <p>Ford Instrument Company, Division of Sperry Rand Corporation, 31-10 Thomson Avenue, Long Island City 1, N. Y. EMITTER MATERIALS STUDY THERMIONIC ENERGY CONVERTERS, by M. Silverberg and L. L. Haring. 31 December 1962, 73 pp. illus. (Task NR 391-429) (Final Technical Report) (Contract Nonr 3696(00))</p> <p>Unclassified Report</p> <p>An experimental program was conducted on selected emitter materials to determine their potential for use in low temperature thermionic energy converters. One oxide emitter and four different dispenser types were evaluated in parallel plate and cylindrical geometry in both glass and metal ceramic construction. With respect to power density the various dispenser emitter types showed suitable and reasonably similar performance. Performance degradation was reversed in some of these diodes and its mechanism explored and explained.</p> | <p>UNCLASSIFIED</p> <p>1. Direct energy conversion</p> <p>2. Thermionics</p> <p>I. M. Silverberg</p> <p>II. L. L. Haring</p> <p>III. Ford Instrument Company</p> <p>IV. Nonr 3696(00)</p> <p>UNCLASSIFIED</p> |
| <p>Ford Instrument Company, Division of Sperry Rand Corporation, 31-10 Thomson Avenue, Long Island City 1, N. Y. EMITTER MATERIALS STUDY THERMIONIC ENERGY CONVERTERS, by M. Silverberg and L. L. Haring. 31 December 1962, 73 pp. illus. (Task NR 391-429) (Final Technical Report) (Contract Nonr 3696(00))</p> <p>Unclassified Report</p> <p>An experimental program was conducted on selected emitter materials to determine their potential for use in low temperature thermionic energy converters. One oxide emitter and four different dispenser types were evaluated in parallel plate and cylindrical geometry in both glass and metal ceramic construction. With respect to power density the various dispenser emitter types showed suitable and reasonably similar performance. Performance degradation was reversed in some of these diodes and its mechanism explored and explained.</p> | <p>UNCLASSIFIED</p> <p>1. Direct energy conversion</p> <p>2. Thermionics</p> <p>I. M. Silverberg</p> <p>II. L. L. Haring</p> <p>III. Ford Instrument Company</p> <p>IV. Nonr 3696(00)</p> <p>UNCLASSIFIED</p> | <p>Ford Instrument Company, Division of Sperry Rand Corporation, 31-10 Thomson Avenue, Long Island City 1, N. Y. EMITTER MATERIALS STUDY THERMIONIC ENERGY CONVERTERS, by M. Silverberg and L. L. Haring. 31 December 1962, 73 pp. illus. (Task NR 391-429) (Final Technical Report) (Contract Nonr 3696(00))</p> <p>Unclassified Report</p> <p>An experimental program was conducted on selected emitter materials to determine their potential for use in low temperature thermionic energy converters. One oxide emitter and four different dispenser types were evaluated in parallel plate and cylindrical geometry in both glass and metal ceramic construction. With respect to power density the various dispenser emitter types showed suitable and reasonably similar performance. Performance degradation was reversed in some of these diodes and its mechanism explored and explained.</p> | <p>UNCLASSIFIED</p> <p>1. Direct energy conversion</p> <p>2. Thermionics</p> <p>I. M. Silverberg</p> <p>II. L. L. Haring</p> <p>III. Ford Instrument Company</p> <p>IV. Nonr 3696(00)</p> <p>UNCLASSIFIED</p> |