

CATALOGED BY ASTIA
As AD No. _____

403446

403 446

.....

63-33

10

PILOT PRODUCTION OF GLASS CRYSTAL HOLDERS

HC - (XM-2)/U; HC - (XM-3)/U; HC - (XM-4)/U

FINAL REPORT: MAY 1958 THROUGH SEPTEMBER 1962

CONTRACT NO.: DA - 36 - 039 - SC - 81255

ORDER NO.: 43810 - PP - 58 - 81 - 81

PLACED BY: (U. S. ARMY SIGNAL SUPPLY AGENCY), PHILADELPHIA, PA.

NOW CALLED: U. S. ARMY ELECTRONIC MATERIAL AGENCY

CONTRACTOR: CORNING GLASS WORKS, CORNING, N. Y.

ASTIA
MAY 3 1963
TISIA

CORNING
CORNING GLASS WORKS
Corning, New York

PILOT PRODUCTION OF GLASS CRYSTAL HOLDERS

HC-(XM-2)/U; HC-(XM-3)/U; HC-(XM-4)/U

FINAL REPORT: MAY 1958 THROUGH SEPTEMBER 1962

CONTRACT NUMBER: DA-36-039-SC-81255

ORDER NUMBER: 43810-PP-58-81-81

PLACED BY: (UNITED STATES ARMY SIGNAL SUPPLY AGENCY)
NOW CALLED: UNITED STATES ARMY ELECTRONIC MATERIEL AGENCY
PHILADELPHIA, PENNSYLVANIA

CONTRACTOR: CORNING GLASS WORKS
CORNING, NEW YORK

REPORT PREPARED BY: R. K. WHITNEY

TABLE OF CONTENTS

<u>SECTION</u>		<u>PAGE</u>
	Title Page	1
	Table Of Contents	2
1.	Abstract	3
2.	Purpose	4
3.	Crystal Holder Nomenclature	5
	HC-(XM-2)/U Photograph And Specification	6-10
	HC-(XM-3)/U Photograph And Specification	11-16
	HC-(XM-4)/U Photograph And Specification	17-20
4.	Statement Of Problem And Planned Approach	21
4.1.	Requirements	21
4.2.	Dimensions	24
4.3.	Materials	26
4.4.	Approach	27
5.	Glass Working And Sealing	28
5.1.	Glass Properties	28
5.2.	Glass Sealing Characteristics	35
5.3.	Crystal Holder Sealing Method	38
5.4.	HC-(XM-2)/U Equipment And Sealing	39
5.5.	HC-(XM-3)/U Equipment And Sealing	85
5.6.	HC-(XM-4)/U Equipment And Sealing	86
6.	Review By Holder Type	106
6.1.	HC-(XM-2)/U Holder	106
6.2.	HC-(XM-3)/U Holder	111
6.3.	HC-(XM-4)/U Holder	121
7.	Conclusions And Recommendations	123
7.1.	HC-(XM-2)/U Holder	123
7.2.	HC-(XM-3)/U Holder	124
7.3.	HC-(XM-4)/U Holder	126
8.	References	127
9.	Acknowledgments	128
	Appendix	129

I. ABSTRACT

A review of requirements, dimensions, and materials is presented with the resultant specification for glass holders. Fundamental glass properties and sealing characteristics are presented. Description of sealing equipment used, plus the process procedures gone through during the preparation of pre-production samples is described. A review of major steps taken for each glass crystal holder is made.

I. ABSTRACT

A review of requirements, dimensions, and materials is presented with the resultant specification for glass holders. Fundamental glass properties and sealing characteristics are presented. Description of sealing equipment used, plus the process procedures gone through during the preparation of pre-production samples is described. A review of major steps taken for each glass crystal holder is made.

2. PURPOSE

The purpose of the work done under the subject contract was to perform Steps I and II of Industrial Preparedness for three crystal holders, HC-(XM-2)/U; HC-(XM-3)/U; and HC-(XM-4)/U. In addition, sealing performance of the holder parts in question was to be demonstrated.

3. CRYSTAL HOLDER NOMENCLATURE

So that all readers of this report are on common ground, a cross reference is given for various types of crystal holders with similar form factors:

<u>Metal Holder</u>	<u>Experimental Glass Holder</u>	<u>Glass Holder</u>	<u>Corning Glass Works Designation For Glass Holder Parts</u>
HC-6/U	HC-(XM-2)/U	HC-27/U	Bulb: T6-B1C; Code 131270 Base: Code 131275
HC-13/U	HC-(XM-3)/U	HC-28/U	Bulb: T6-C1C; Code 131280 Base: Code 131285
HC-18/U	HC-(XM-4)/U	HC-26/U	Bulb: T3-R1C; Code 131260 Base: Code 131265
HC-25/U	-	HC-29/U	Bulb: T3-R1C; Code 131260 Base: Not Designated

CRYSTAL HOLDER

HC-(XM-2)/U OR HC-27/U

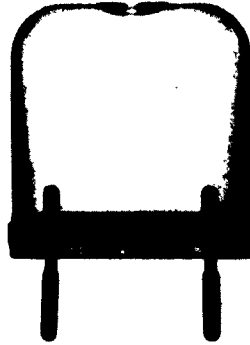

CORNING GLASS WORKS

PARTS DESIGNATION

Bulb T6-B1C
Code 131270

Base .728" Long, .321" Wide
With Two Leads .430" Long
Code 131275

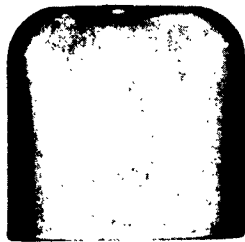



CORNING GLASS WORKS
 Product Engineering
 Receiver Bulb Sales Dept.
 Corning, New York

Date 3/15/62 Code 131270
 Product Specification
 Bulb, T6-BIC

Supersedes 10/3/60 Page 1 of 1
 Bulb For Crystal Holder HC-2770

1. Glass: 7052
2. Finish: Mold blown, open end diamond saw cut, glazed, and annealed
3. Visual Inspection: Standard 7052 tubing inspection, except as noted:
 - 3.1. Scale: Reject all degrees.
 - 3.2. Stones: Maximum acceptable 1/32" greatest dimension, or two or more where area does not exceed one stone 1/32" square well buried. Reject all degrees in area 3/32" from cut edge.
 - 3.3. Knots: Maximum acceptable 1/32" greatest dimension, or two or more where area does not exceed one knot 1/32" square well buried. Reject all degrees in area 3/32" from cut edge.
 - 3.4. Chips: Reject all degrees on bulb top and on side more than 3/32" from cut edge. Fine grinding or cutting chips permitted, less than 3/32" from cut edge. Maximum acceptable on side of bulb, one that does not reduce wall below minimum dimensions and is less than 1/32" in greatest dimension. No chips are allowed at cut edge that exceed one-third wall thickness of bulb in question.
 - 3.5. Adhered Glass: Reject all degrees.
 - 3.6. Dirty Bulb: Reject all degrees inside and outside. Bulbs shall be free of glass dust, dirt, grease, and any foreign material.
 - 3.7. Scuff Or Scratch: Reject bulb if a single scratch exceeds one-half of the bulb periphery. Reject bulb if two or more scratches or scuffs exceeds one-quarter of the bulb periphery.
 - 3.8. Blister And/Or Seed: Reject all open blisters or seeds. Reject all blisters or seeds with maximum dimension greater than 1/64".
 - 3.9. Airline: Reject all open airlines. Reject all airlines greater than 1/64" wide.
 - 3.10. Cord: Reject bulb if cord exceeds one-quarter of the periphery. Reject all degrees in area 3/32" from cut edge.
 - 3.11. Checks And Cracks: Reject all degrees.
 - 3.12. Slack Blown: Reject all degrees.
4. Dimensions: See drawing and notes.

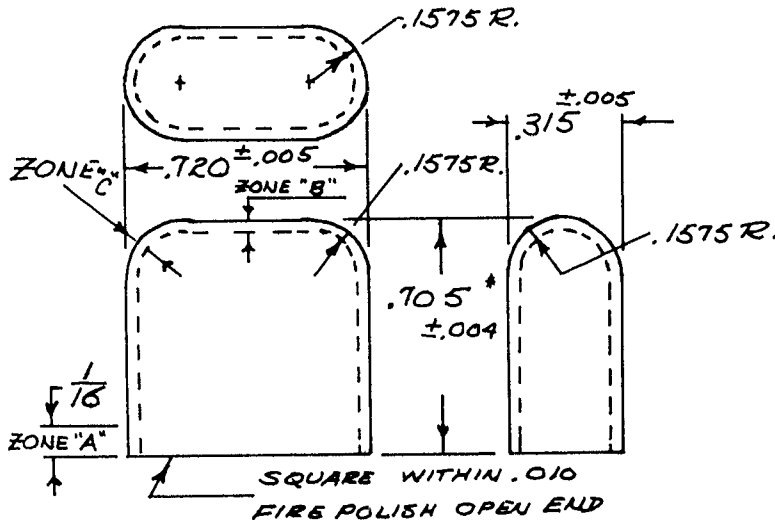

Wall Thickness Notes:

1. Wall .035-.045 desired throughout.
2. Limits:
 - Zone A: .027-.043
 - Zone B: .020-.045
(Center closed end)
 - Zone C: .011-.035
(Corner radius closed end)

*Change
 **Addition
 ***Deletion

- 7 -

Scale :

PC No.

All Dimensions in Inches. Dimensions shown without tolerance are design centers.



CORNING GLASS WORKS

Product Engineering
Receiver Bulb Sales Dept.
Corning, New York

Date 1/11/62 Code 131275
Product Specification
Base .728 Long, .321 Wide With
Two Leads .430 Long

Supersedes 6/7/61 Page 1 of 3
Base For Crystal Holder HC-277U

1. Material: Glass: 7052 clear
Metal: Kovar or equal
2. Finish: Molded finish
3. Dimensions: See drawings on Pages 2 and 3, plus following notes:
 - 3.1. Recess required, but dimensions not controlled and are for reference only.
 - 3.2. Draft is optional.
 - 3.3. At either surface through which pins emerge from the main body of the base, glass meniscus shall not extend on the pins more than .025. Meniscus check or crack shall not be rejectable.
 - 3.4. When Kovar ring is specified to be glazed, this glaze shall completely surround the ring, leaving no bare metal exposed. This ring shall be securely sealed all around its perimeter to the main body of the base glass.

*Change
**Addition
***Deletion

- 8 -

Scale :

PC No. RB-690

All Dimensions in Inches. Dimensions shown without tolerance are design centers.



CORNING GLASS WORKS

Product Engineering
Receiver Bulb Sales Dept.
Corning, New York

Date 1/11/62 Code 131275
Product Specification
Base .728 Long, .321 Wide With
Two Leads .430 Long

Supersedes 6/7/61 Page 3 of 3

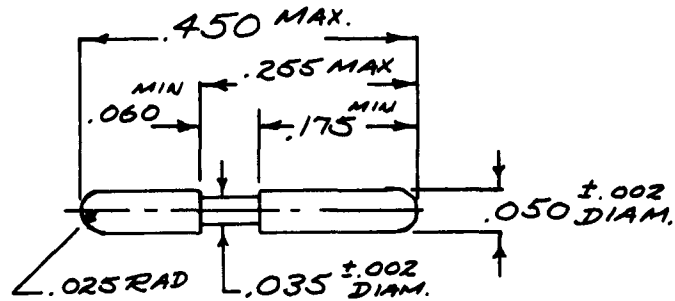

KOVAR LEAD (2 PER ASSEMBLY)

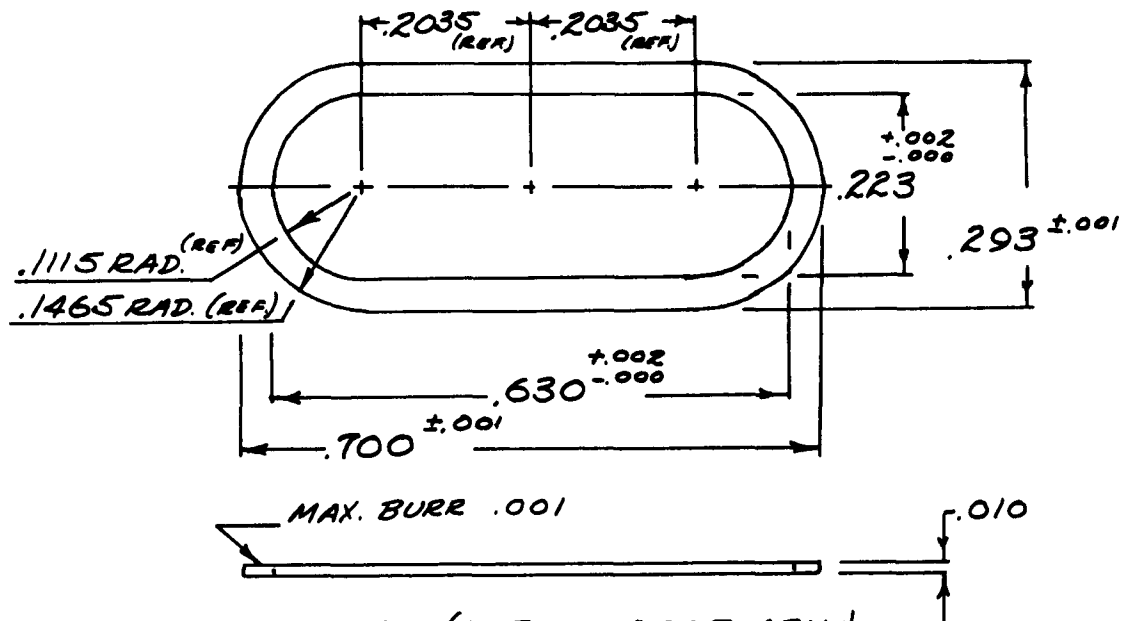

KOVAR RING (1 PER ASSEMBLY)

THICKNESS AFTER GLAZING ALL OVER
WITH 7052 GLASS -.020 ±.005, SEE NOTE 3.4

*Change
**Addition
***Deletion

- 10 -

Scale : 5X

PC No. RB-690

All Dimensions in Inches. Dimensions shown without tolerance are design centers.

CRYSTAL HOLDER

HC-(XM-3)/U OR HC-28/U



CORNING GLASS WORKS

PARTS DESIGNATION

Bulb T6-C1C
Code 131280

Base .728" Long, .32" Wide
With Two Leads 1.710" Long
Code 131285

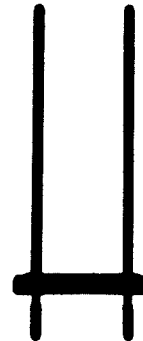
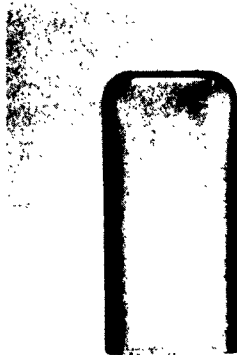



CORNING GLASS WORKS

Product Engineering
Receiver Bulb Sales Dept.
Corning, New York

Date 3/15/62 Code 131280
Product Specification
Bulb, T6-C1C

Supersedes 10/3/60 Page 1 of 2
Bulb For Holder HC-287U

1. Glass: 7052
2. Finish: Mold blown, open end diamond saw cut, glazed, and annealed
3. Visual Inspection: Standard 7052 tubing inspection per Master Specification EPS-9, except as noted:
 - 3.1. Scale: Reject all degrees.
 - 3.2. Stones: Maximum acceptable 1/32" greatest dimension, or two or more where area does not exceed one stone 1/32" square well buried. Reject all degrees in area 3/32" from cut edge.
 - 3.3. Knots: Maximum acceptable 1/32" greatest dimension, or two or more where area does not exceed one knot 1/32" square well buried. Reject all degrees in area 3/32" from cut edge.
 - 3.4. Chips: Reject all degrees on bulb top and on side more than 3/32" from cut edge. Fine grinding or cutting chips permitted, less than 3/32" from cut edge. Maximum acceptable on side of bulb, one that does not reduce wall below minimum dimensions and is less than 1/32" in greatest dimension. No chips are allowed at cut edge that exceed one-third wall thickness of bulb in question.
 - 3.5. Adhered Glass: Reject all degrees.
 - 3.6. Dirty Bulb: Reject all degrees inside and outside. Bulbs shall be free of glass dust, dirt, grease, and any foreign material.
 - 3.7. Scuff Or Scratch: Reject bulb if a single scratch exceeds one-half of the bulb periphery. Reject bulb if two or more scratches or scuffs exceed one-quarter of the bulb periphery.
 - 3.8. Blister And/Or Seed: Reject all open blisters or seeds. Reject all blisters or seeds with maximum dimension greater than 1/64".
 - 3.9. Airline: Reject all open airlines. Reject all airlines greater than 1/64" wide.
 - 3.10. Cord: Reject bulb if cord exceeds one-quarter of the periphery. Reject all degrees in area 3/32" from cut edge.
 - 3.11. Checks And Cracks: Reject all degrees.
 - 3.12. Slack Blown: Reject all degrees.

*Change
**Addition
***Deletion

- 12 -

Scale :

All Dimensions in Inches. Dimensions shown without tolerance are design centers. PC No. RB-750



CORNING GLASS WORKS

Product Engineering
Receiver Bulb Sales Dept.
Corning, New York

Date 3/15/62
Product Specification
Bulb, T6-C1C

Code 131280

Supersedes 10/3/60 Page 2 of 2

Wall Thickness Notes:

1. Wall .035-.045 desired throughout.
2. Limits:
 - Zone A: .027-.043
 - Zone B: .020-.045 (Center closed end)
 - Zone C: .011-.035 (Corner radius closed end)

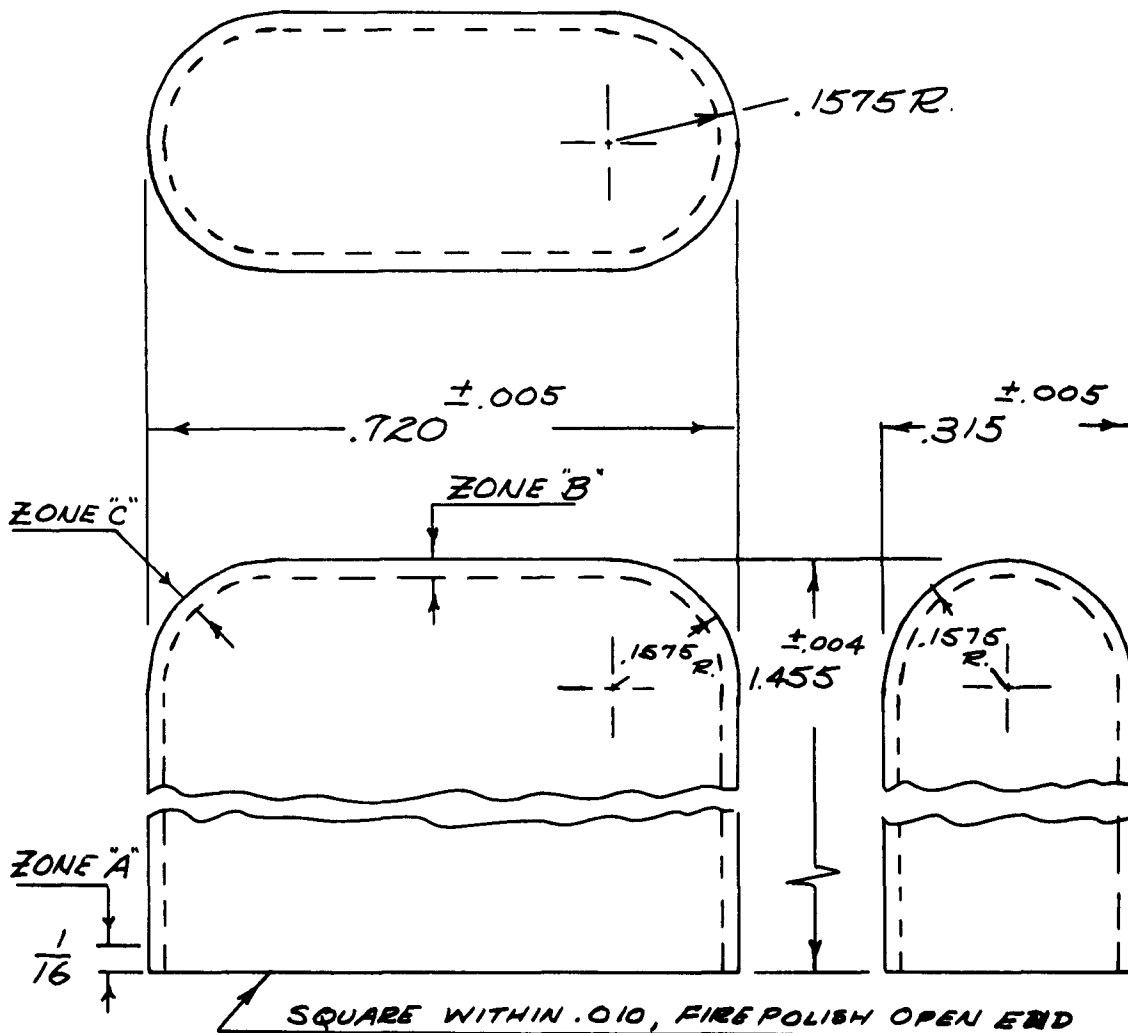

*Change
**Addition
***Deletion

- 13 -

Scale : 5X

PC No. RB-750

All Dimensions in Inches. Dimensions shown without tolerance are design centers.



CORNING GLASS WORKS

Product Engineering
Receiver Bulb Sales Dept.
Corning, New York

Date 3/15/62 Code 131285
Product Specification
Base .728 Long, .321 Wide With
Two Leads 1.710 Long

Supersedes 1/11/62 Page 1 of 3
Base For Crystal Holder HC-287U

1. Material: Glass: 7052 clear
Metal: Kovar or equal
2. Finish: Molded finish
3. Dimensions: See drawings on Pages 2 and 3, plus following notes:
 - 3.1. Recess required, but dimensions not controlled and are for reference only.
 - 3.2. Draft is optional.
 - 3.3. At either surface through which pins emerge from the main body of the base, glass meniscus shall not extend on the pins more than .025. Meniscus check or crack shall not be rejectable.
 - 3.4. When Kovar ring is specified to be glazed, this glaze shall completely surround the ring, leaving no bare metal exposed. The ring shall be securely sealed all around its perimeter to the main body of the base glass.

*Change
**Addition
***Deletion

- 14 -

Scale :

All Dimensions in Inches. Dimensions shown without tolerance are design centers. PC No. RB-749



CORNING GLASS WORKS

Product Engineering
Receiver Bulb Sales Dept.
Corning, New York

Date 3/15/62 Code 131285

Product Specification

Base .728 Long, .321 Wide With
Two Leads 1.710 Long

Supersedes 1/11/62 Page 3 of 3

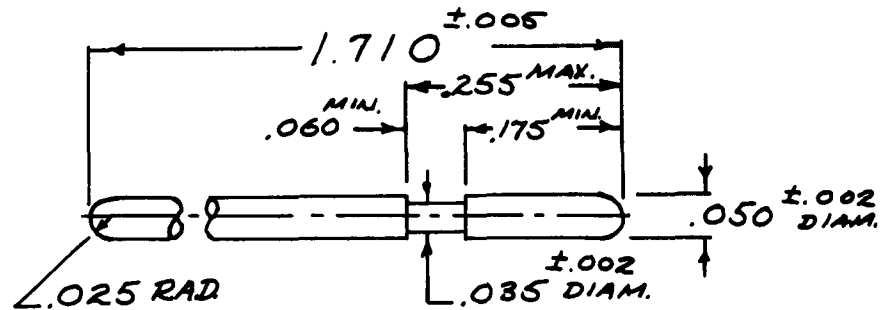

KOVAR LEAD (2 PER ASSEMBLY)

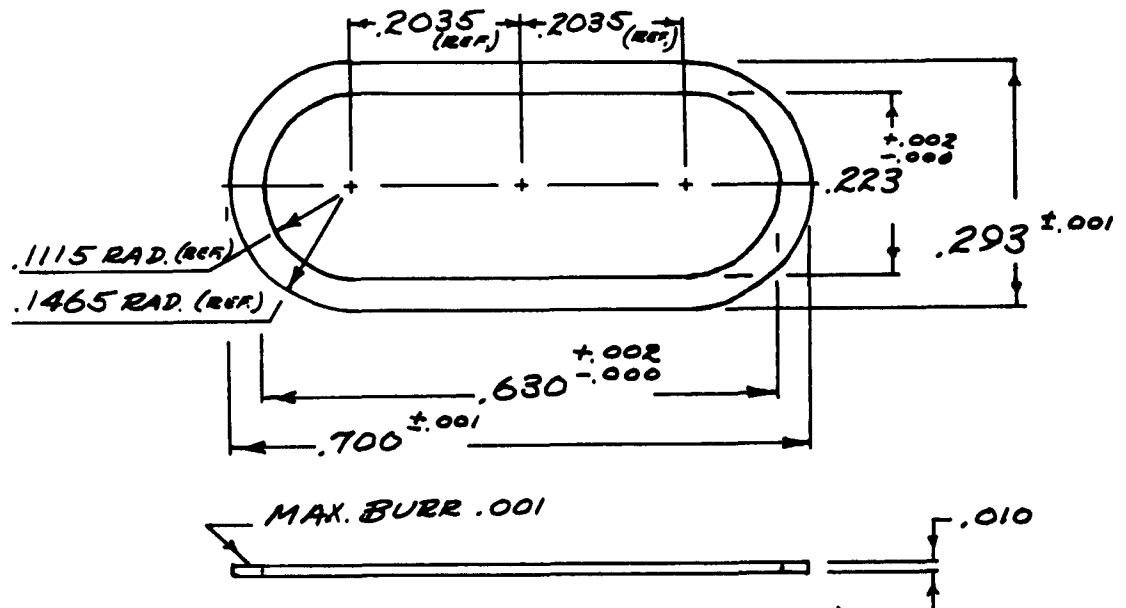

KOVAR RING (1 PER ASSEMBLY)

THICKNESS AFTER GLAZING ALL OVER
WITH 7052 GLASS - .020 ±.005, SEE NOTE 2.4

*Change
**Addition
***Deletion

- 16 -

Scale : 5X

PC No. RB-749

All Dimensions in Inches. Dimensions shown without tolerance are design centers.

CRYSTAL HOLDER

HC-(XM-4)/U OR HC-26/U

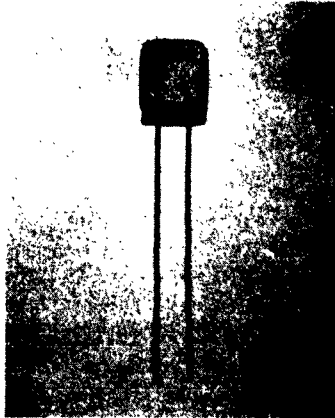

CORNING GLASS WORKS

PARTS DESIGNATION

Bulb T3-R1C
Code 131260

Base .365" Long, .098" Wide
With Two Leads 1.730" Long
Code 131265

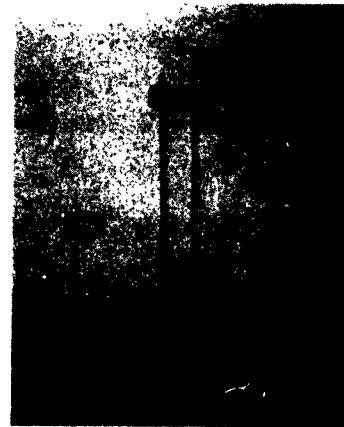



CORNING GLASS WORKS

Product Engineering
Receiver Bulb Sales Dept.
Corning, New York

Date 3/15/62
Product Specification

Code 131260

Bulb, T3-RIC

Supersedes 10/4/60 Page 1 of 2

Bulb For Crystal Holder HC-25/U
HC-25/U

1. Glass: 7052
2. Finish: Mold blown, open end cut, glazed, and annealed
3. Visual Inspection: Standard 7052 tubing inspection, except as noted:
 - 3.1. Scale: Reject all degrees.
 - 3.2. Stones: Maximum acceptable 1/32" greatest dimension, or two or more where area does not exceed one stone 1/32" square well buried. Reject all degrees in area 3/16" from cut edge and in Zone A.
 - 3.3. Knots: Maximum acceptable 1/32" greatest dimension, or two or more where area does not exceed one knot 1/32" square well buried. Reject all degrees in area 3/16" from cut edge and in Zone A.
 - 3.4. Chips: Reject all degrees on bulb top and on side more than 3/32" from cut edge. Fine grinding or cutting chips permitted, less than 3/32" from cut edge. Maximum acceptable on side of bulb, one that does not reduce wall below minimum dimensions and is less than 1/32" in greatest dimension. No chips are allowed at cut edge that exceed one-third wall thickness of bulb in question.
 - 3.5. Adhered Glass: Reject all degrees.
 - 3.6. Dirty Bulb: Reject all degrees inside and outside. Bulbs shall be free of glass dust, dirt, grease, and any foreign material.
 - 3.7. Scuff Or Scratch: Reject bulb if a single scratch exceeds one-half of the bulb periphery. Reject bulb if two or more scratches or scuffs exceed one-quarter of the bulb periphery.
 - 3.8. Blister And/Or Seed: Reject all open blisters or seeds. Reject all blisters or seeds with maximum dimension greater than 1/64".
 - 3.9. Airline: Reject all open airlines. Reject all airlines greater than 1/64" wide.
 - 3.10. Cord: Reject bulb if cord exceeds one-quarter of the periphery. Reject all degrees in Zone A.
 - 3.11. Checks And Cracks: Reject all degrees.
 - 3.12. Slack Blown: Reject all degrees.

*Change
**Addition
***Deletion
All Dimensions in Inches. Dimensions shown without tolerance are design centers.

- 18 -

Scale :

PC No.



CORNING GLASS WORKS

Product Engineering
Receiver Bulb Sales Dept.
Corning, New York

Date 3/15/62
Product Specification

Code 131260

Bulb, T3-RIC

Supersedes 10/4/60 Page 2 of 2

Wall Thickness Notes:

1. Wall .022-.028 desired throughout Zone D.
2. Limits:
 - Zone A: .017-.033
 - Zone B: .030-.045 (Center closed end)
 - Zone C: .010-.040 (Corner radius of closed end)

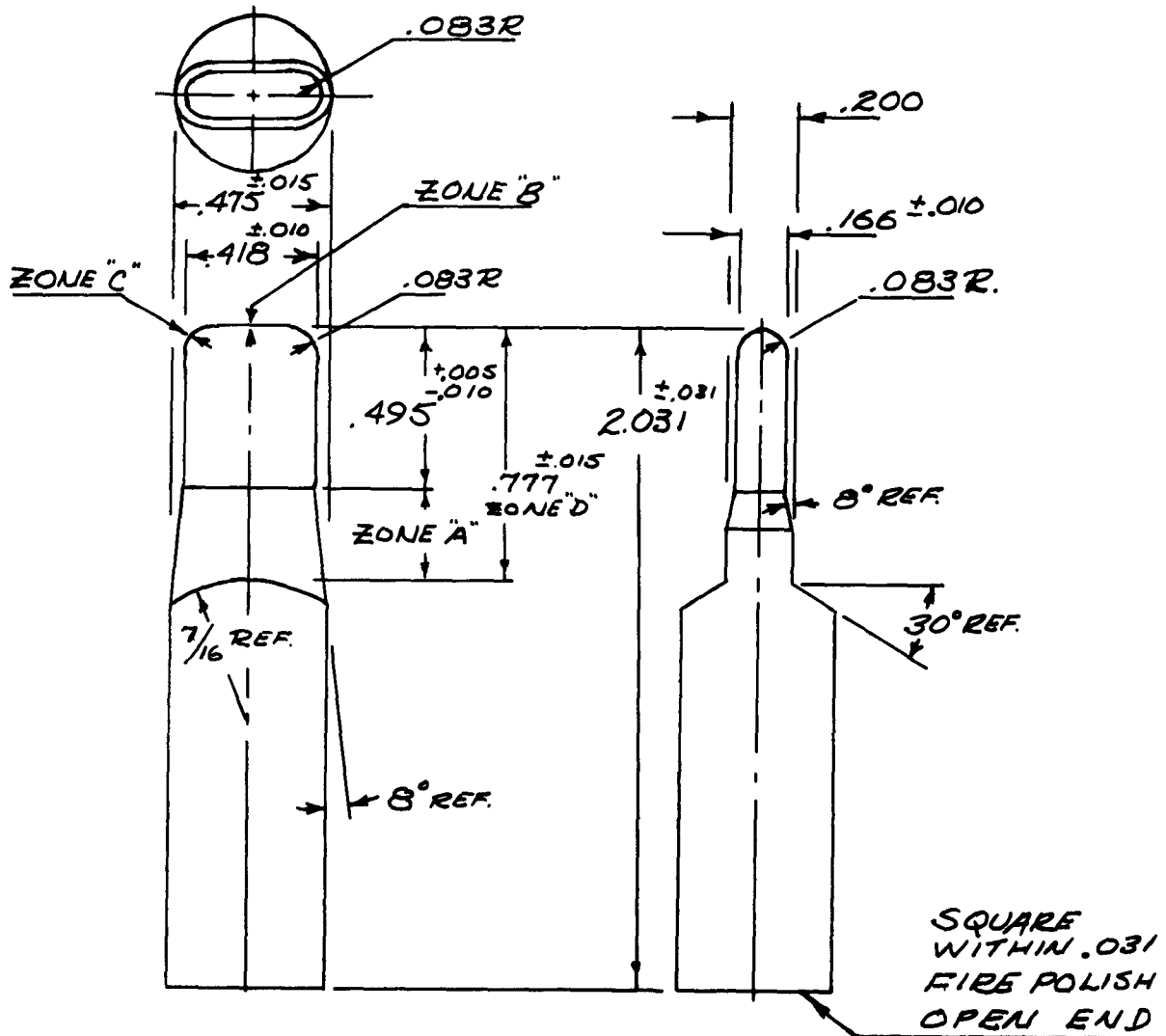

*Change
 **Addition
 ***Deletion

- 19 -

Scale: 2X

PC No.

All Dimensions in Inches. Dimensions shown without tolerance are design centers.



CORNING GLASS WORKS

Product Engineering
Receiver Bulb Sales Dept.
Corning, New York

Date 1/11/62 Code 131265
Product Specification

Base .365 Long, .098 Wide With
Two Leads 1.730 Long

Supersedes 6/7/61 Page 1 of 1
Base For Crystal Holder HC-26/U

1. Material: Glass: 7052 clear
Metal: Kovar or equal
2. Finish: Molded finish
3. Dimensions: See drawing on Page 1, plus following note:
 - 3.1. At either surface through which leads emerge from the main body of the base, glass meniscus shall not extend on the leads more than .025. Meniscus check or crack shall not be rejectable.

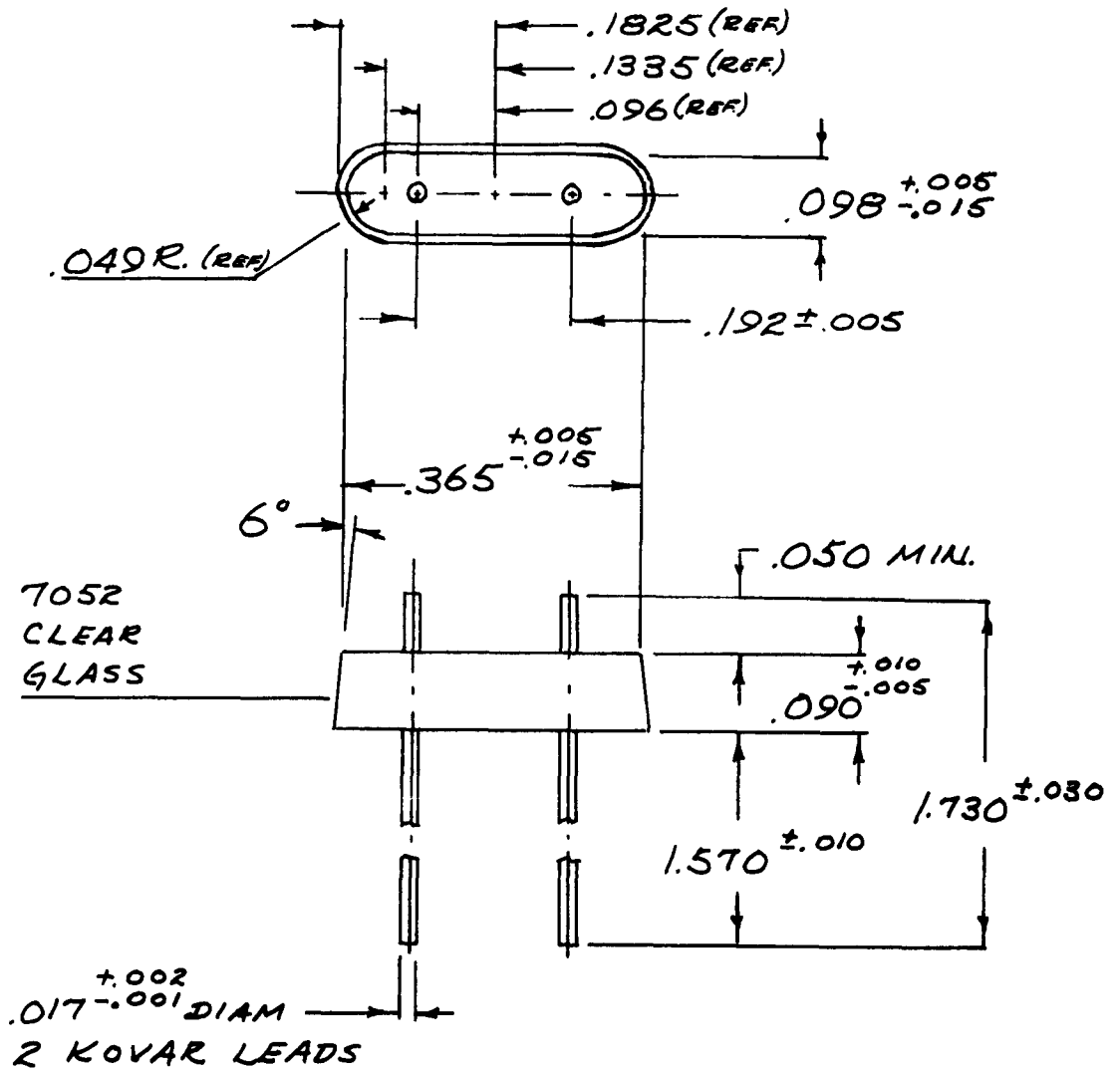

*Change
**Addition
***Deletion

All Dimensions in Inches. Dimensions shown without tolerance are design centers.

- 20 -

Scale : 5X

PC No. RB-689

4. STATEMENT OF PROBLEM AND PLANNED APPROACH

This report will describe procedures and techniques for sealing together bulbs (covers) and bases of glass crystal holders. Detailed production processing information for bulbs and bases is specifically excluded as a part of this contract's work.

The detailed requirements for the glass crystal holders covered in this work are described for the reader's reference.

4.1. The glass crystal holders are to meet the applicable requirements of MIL-H-10056B. In addition, the following requirements are to be met.

4.1.1. Crystal units sealed in these glass holders shall give equivalent performance to crystal units soldered in the regular metal holders when tested in accordance with MIL-C-3098B.

4.1.2. The glass shall be clean and contain no bubbles greater than 1/8". There shall be no loosening of pins for the base, and the glass shall contain no radial or other detrimental cracks when examined as specified in Paragraph 4.6.1.1. of MIL-H-10056B.

4.1.3. The sealed crystal holder shall be placed on a grounded metal plate and the electrode of a Tesla coil placed across both pins. The

4. STATEMENT OF PROBLEM AND PLANNED APPROACH (Continued)

4.1. (Continued)

4.1.3. (Continued)

Tesla coil shall be energized. After a period of forty-eight hours, the test shall be repeated. When tested in this fashion, the presence of a light blue glow discharge which fills the holder shall be taken as evidence of a vacuum. After the forty-eight hour period, there shall be no evidence of leakage. A purplish blue glow discharge, restricted in area, or a spark discharge shall be considered as evidence of leakage. (Such a test may be detrimental to the plating on a quartz crystal.)

4.1.4. The HC-(XM-2)/U and HC-(XM-3)/U holders shall sustain a load of thirty pounds along the axis of the pins; the HC-(XM-4)/U holder shall sustain a load of ten pounds along the axis of the pins. These loads are to be applied according to Paragraph 4.6.4. of MIL-H-10056B. When tested as described, the glass shall show no evidence of loosening from the pins or separation of the base from the cover at the base seal.

4. STATEMENT OF PROBLEM AND PLANNED APPROACH (Continued)

4.1. (Continued)

4.1.5. The sealed glass holder shall be held at a temperature of -55° C. for ten minutes and immediately immersed in boiling water. There shall be no evidence of cracking, breaking, or leakage.

4.1.6. Sealing of pre-production samples of the crystal holders is to be accomplished on sealing equipment owned by the United States Government (or equivalent equipment). The crystal holder is to be evacuated and the sealing shall be accomplished without raising the crystal to a temperature exceeding 250° C. (This stipulation was modified)

This sealing equipment was purchased by the Government from Philips Electronics Industries, Limited, in Toronto, Ontario, Canada.

4. STATEMENT OF PROBLEM AND PLANNED APPROACH (Continued)

4.2. The specified dimensions and materials of these three glass crystal holders are given.

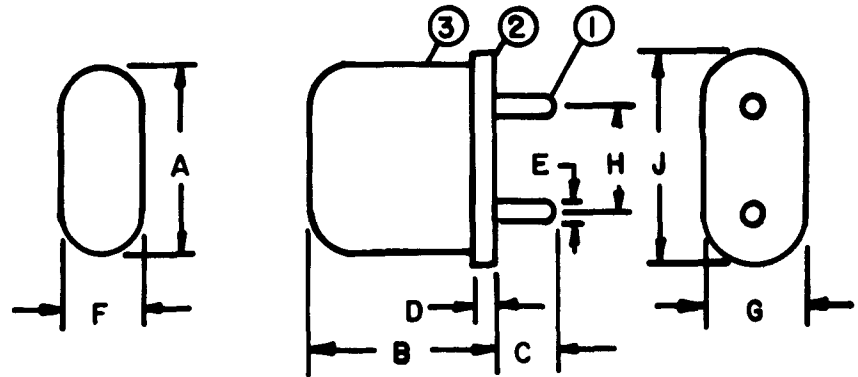

Dimension	Holder Type		
	HC-(XM-2)/U	HC-(XM-3)/U	HC-(XM-4)/U
A	.720 ± .005	.720 ± .005	.418 ± .010
B	.765 ± .010	1.516 ± .010	.515 + .010 - .015
C	.238 + .010 - .015	.238 + .010 - .015	1.500 Minimum
D	.065 ± .010	.065 ± .010	Not Specified
E	.050 ± .002	.050 ± .002	.017 + .002 - .001
F	.315 ± .005	.315 ± .005	.166 ± .010
G	.345 + .000 - .005	.345 + .000 - .005	.166 ± .010
H	.486 ± .008	.486 ± .008	.192 ± .008
J	.750 + .000 - .005	.750 + .000 - .005	.418 ± .010

4. STATEMENT OF PROBLEM AND PLANNED APPROACH (Continued)

4 2. (Continued)

Notes:

1. All dimensions in inches.
2. Item No. 1 shall project .040 inches above the inside glass seal for HC-(XM-2)/U and HC-(XM-4)/U and 1.340 inches for HC-(XM-3)/U.
3. Thickness of glass of bulb (cover) is described in detail in Corning part specifications.

<u>Item Number</u>	<u>Description</u>	<u>Material</u>	<u>Quantity</u>
1	Pin (Lead)	Kovar ^(R) or equal	2
2	Base	7052 glass	1
3	Bulb (Cover)	7052 glass	1

(R) Registered trademark of Westinghouse Electric Corporation

The dimensions and tolerances originally specified by the United States Government were identical to those specified for similar metal holders. The tolerances and dimensions listed above were agreeably modified to provide compatibility with glass working techniques which are indeed different from metal working techniques. The glass holder's finished form factor, in the area where bulb and base are sealed, will be distorted from that depicted in the outline drawing.

4. STATEMENT OF PROBLEM AND PLANNED APPROACH (Continued)

4.3. The materials to be used are Corning's PYREX Brand 7052 Glass and Kovar Alloy. These are the materials that were used by Philips Electronics Industries, Limited (previously called Canadian Radio Manufacturing Corporation, Limited) of Toronto, Ontario, Canada, for their glass crystal holders designated RG-1 and RG-2. These two holders are similar to the HC-(XM-2)/U and HC-(XM-4)/U holders respectively. In view of the stringent requirements noted above, in particular the severe thermal shock test, low thermal expansion materials are required for these holders. Lower thermal expansion materials are available, but sealing and annealing conditions, plus compatibility with a 250° C. desired maximum quartz temperature, indicate that the 7052 Glass and Kovar combination is an optimum choice of materials.

4. STATEMENT OF PROBLEM AND PLANNED APPROACH (Continued)

4.4. The approach for completion of the work was planned along conventional lines: Design glass parts that are compatible with sealing equipment and specified dimensions; dimensionally test these parts by actually sealing experimentation; subject sealed holders to preproduction tests; and produce pilot run quantities. Corning Glass Works would produce the bulbs; bases would be obtained from a sub-contractor - L. L. Constantin, Lodi, New Jersey; sealing would be done at Scientific Radio Products, Inc., Loveland, Colorado, and McCoy Electronics Company, Mount Holly Springs, Pennsylvania.

5. GLASS WORKING AND SEALING

5.1. Glass is a noncrystalline material that has no regular internal structure. It is rigid at ordinary temperatures and soft or almost fluid at high temperatures. It has no definite freezing point.

At ordinary temperatures the viscosity of glass is so high that it can be considered to be infinite. As the temperature is raised, however, the viscosity decreases and the glass gradually assumes the character of a liquid. Four points on the viscosity-temperature curve have been arbitrarily chosen to represent the softness of the glass at important points in its change from solid to liquid. Figure 1 is a viscosity-temperature curve for 7052 glass.

The following definitions for strain, annealing and softening points are taken from those tentatively adopted by the American Society For Testing Materials; that for Working Point is employed by Corning Glass Works and corresponds to the upper end of the working range as defined by the American Society For Testing Materials.

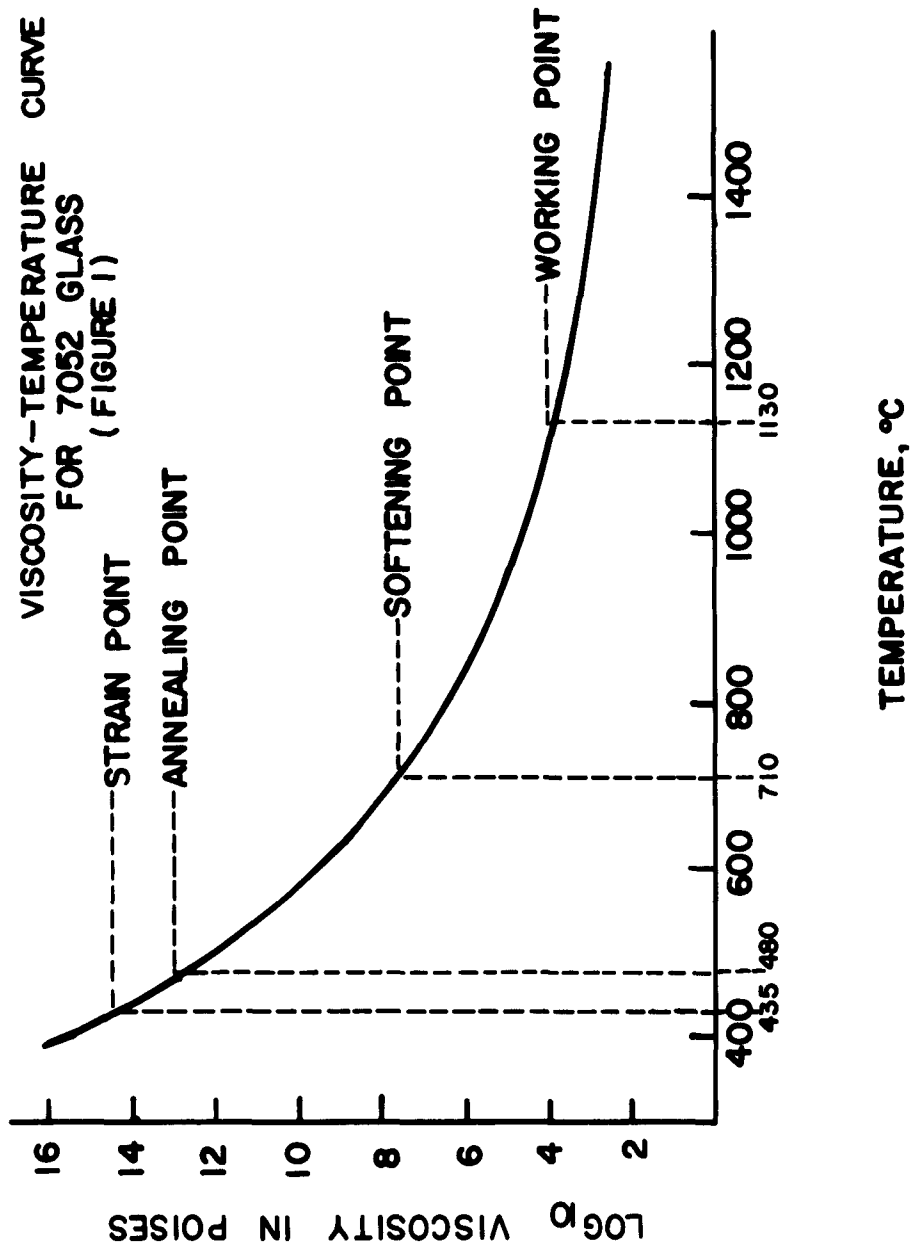

5. GLASS WORKING AND SEALING (Continued)

5.1. (Continued)

Strain Point

The temperature at the lower end of the annealing range, at which the internal stress is substantially relieved in four hours. The strain point corresponds to a viscosity of $10^{14.50}$ poises when measured by the Tentative Method Of Test For Annealing Point And Strain Point Of Glass (A.S.T.M. Designation: C. 336). The strain point for 7052 glass is 435° C.

Annealing Point

The temperature at the upper end of the annealing range, at which the internal stress is substantially relieved in fifteen minutes. The annealing point corresponds to a viscosity of $10^{13.00}$ poises when measured by the Tentative Method Of Test For Annealing Point And Strain Point Of Glass (A.S.T.M. Designation: C. 336). The annealing point for 7052 glass is 480° C.

In an annealing operation the glass is heated somewhat above the annealing point and slowly cooled to somewhat below the strain point. Deformation of the glass can become a problem about 50° C. above the annealing point.

5. GLASS WORKING AND SEALING (Continued)

5.1. (Continued)

Softening Point

The temperature at which a uniform fiber, 0.55 to 0.75 mm in diameter and 23.5 cm. in length, elongates under its own weight at a rate of 1 mm per minute when the upper 10 cm of its length is heated in the manner prescribed in the Tentative Method Of Test For Softening Point Of Glass (A.S.T.M. Designation: C. 338) at a rate of approximately 5° C. per minute. For glass of density near 2.5 gm./cm.³ this temperature corresponds to a viscosity of 10^{7.6} poises. The softening point for 7052 glass is 710° C.

At the softening point the glass deforms very rapidly and starts to adhere to other bodies.

Working Point

The temperature where the glass is soft enough for hot working by most of the common methods. Viscosity at the working point is 10⁴ poises. The working point for 7052 glass is 1130° C.

5. GLASS WORKING AND SEALING (Continued)

5.1. (Continued)

As the temperature is raised, glasses tend to expand. In general the change is smaller than with most ordinary substances, but because of the nature of glass the expansion is often quite important, both in connection with heat shock resistance and in connection with rigid seals to other materials such as metals, ceramics and other glasses.

Figure 2 shows "expansion curves" for 7052 glass and Kovar alloy in which the change in length per unit length ($\Delta L/L$) is plotted against the temperature (T) in degrees centigrade. Actually this should be called an elongation curve since the quantity plotted against temperature is the specific elongation and not the expansion coefficient. It will be noted that the curve is initially linear but that it swings upward, indicating a higher rate of expansion, as the annealing zone is approached. The quantity which is usually referred to by the term "expansion", actually "Thermal Expansion Coefficient", is the slope of the initial, linear portion of this curve. To be more precise, it is the average change of length per unit length per degree C. between 0° C. and 300° C. This figure gives a good indication of the ability of the glass to withstand thermal shock.

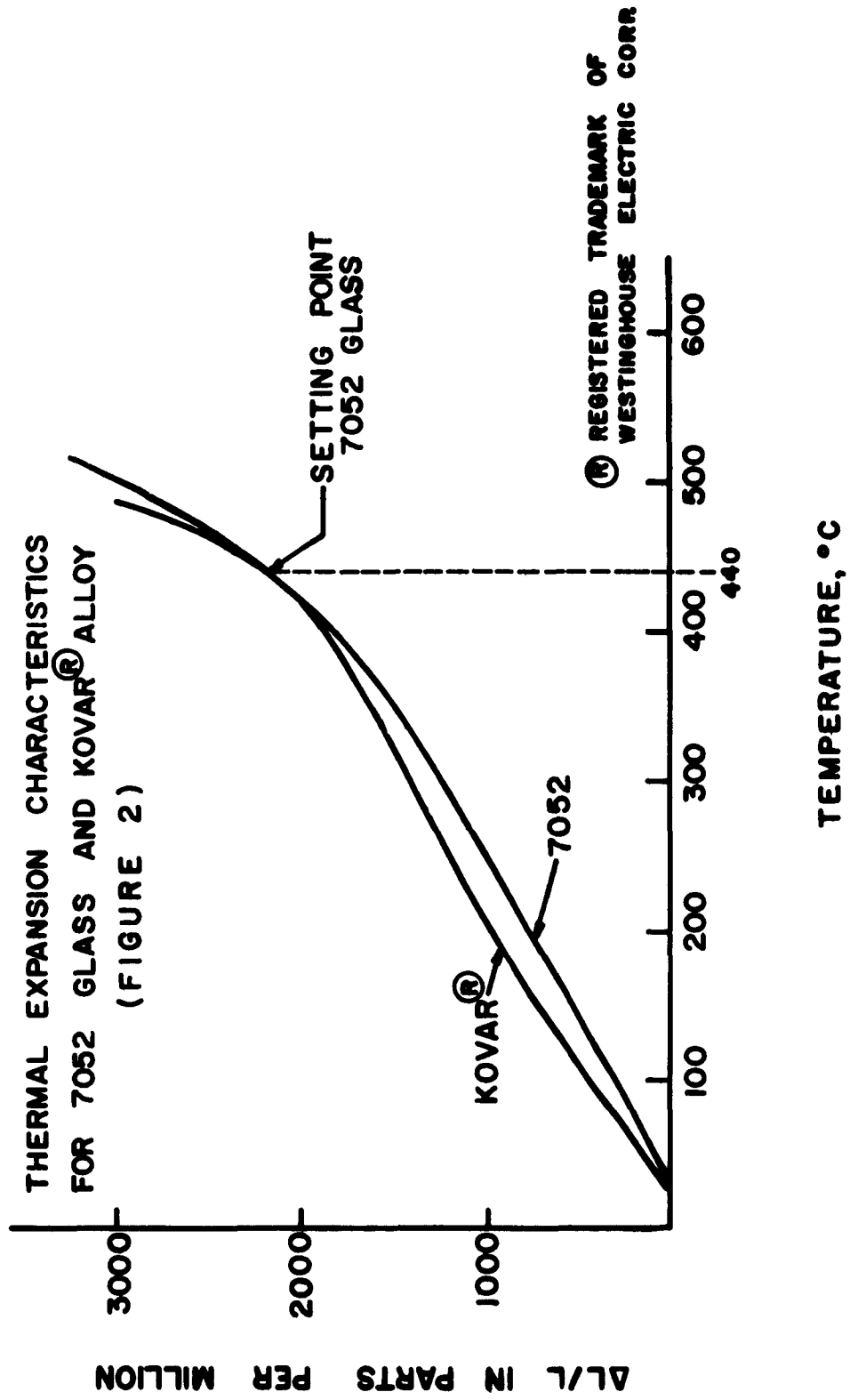

5. GLASS WORKING AND SEALING (Continued)

5.1. (Continued)

For sealing applications, values are often given for the average expansion coefficient from room temperature to the setting point. The setting point is arbitrarily defined as that point on the viscosity-temperature curve that is 5° C. above the strain point. A comparison of the expansion coefficients to the setting point between a material of known expansion and a particular glass will give a good estimate of sealing compatibility. However, for precise predictions of residual sealing stresses due to expansion differences, complete expansion curves for the sealing materials should be consulted.

The thermal expansion coefficient of 7052 glass between 0° - 300° C. is $46 \times 10^{-7}/^{\circ} \text{C}$. The thermal expansion coefficient of 7052 glass from room temperature to the setting point is $53 \times 10^{-7}/^{\circ} \text{C}$.

The thermal expansion differential between Kovar and 7052 glass at the setting point of 7052 (440° C.) is twenty parts per million. In general, this low a value is interpreted as a very good sealing condition.

5. GLASS WORKING AND SEALING (Continued)

5.2. When properly fabricated parts for the three crystal holders are sealed together, glass-to-glass seals are made. Whenever glass seals are made, it is essential that the glass be "worked". "Working" means that movement of the glass must occur so that the two adjacent glass members are intimately intermingled. Glass-to-glass seals are influenced by three factors: time, temperature, and the amount of working. In making a seal of the type required for these crystal holders, the amount of seal working is restricted by physical and mechanical limitations. Furthermore, time and temperature must be controlled so that heat transfer to the plated quartz blank is minimized. The success of a glass seal is also a function of the rate of cooling between the annealing point and the strain point of the glass. At a high rate of cooling, a permanent stress may be left which may cause failure later.

With these limitations and factors in mind, the discussion is now directed towards crystal holders. These principles will apply regardless of what sealing equipment is used. An understanding of the principles will only aid in making better seals. Accordingly, this section will not deal with the equipment used, but with the sealing process.

5. GLASS WORKING AND SEALING (Continued)

5.2. (Continued)

The minimum temperature at which 7052 glass can be sealed and still provide the proper glass flow to prevent re-entrant angles is in the 825° C. to 900° C. region. The seal area at this temperature is bright cherry red to orange in color.

All the specific temperatures that are involved in this seal system are listed:

- 250° C. - Desired maximum quartz limit
- 435° C. - Strain Point, 7052 Glass
- 480° C. - Annealing Point, 7052 Glass
- 710° C. - Softening Point, 7052 Glass
- 840° C. - Approximate sealing temperature in this system (See Section 5.4.2.4.)

Achievement and maintenance of these temperatures at the proper time in the sealing cycle requires good control of the operation. From a purely theoretical standpoint, the sealing system for these crystal holders is one which is filled with compromises.

The seal area cannot be raised to a temperature as high as might be desired. This limitation means that the glass parts must be of sufficient accuracy and fit with one another so that when heated to the minimum temperature of approximately 825° C., sufficient flow will occur.

5. GLASS WORKING AND SEALING (Continued)

5.2. (Continued)

The physical arrangement of the sealing equipment and the parts to be sealed do not provide a means of working the seal area as thoroughly as might be desired. As in the preceding paragraph, glass part accuracy and alignment must maximize the amount of working possible so that, coupled with the 825° C. temperature, smooth transitions from one glass member to the other glass member are achieved. Without proper fillets and smooth transitions, sharp re-entrant angles will be left in the seal area. Such sharp notches will be sources for seal failures,

The actual temperature of the seal area must be cooled at a rate, through the annealing range of the glass (from above 480° C. to below 435° C.) that is sufficiently slow to relieve stresses introduced during sealing. These stresses, if not relieved, may be the source of subsequent failures. In normal glass working practices, the best annealing is done as a separate operation in which the whole article is carried through a complete annealing cycle. Obviously this cannot be done since the temperature sensitive quartz blank would not survive such a cycle.

The sealing equipment used optimized the adverse circumstances encountered in the sealing system. Good seal geometry (lack of re-entrancies and smooth fillets) is possible, and good quartz units can be sealed in glass holders.

5. GLASS WORKING AND SEALING (Continued)

5.3. Now that basic sealing principles have been discussed, fundamental methods for sealing the three glass holders will be described. The HC-(XM-2)/U and HC-(XM-3)/U holders are sealed using an induction heating technique. The HC-(XM-4)/U holder is sealed using a flame heating method.

The HC-(XM-2)/U and HC-(XM-3)/U holders are located and held in fixtures designed to push or squeeze the bulb and base together by a spring action. The holder is evacuated by placing this fixture under a bell jar during preheating and sealing. Heat is applied to the sealing area of the bulb and base through a Kovar ring which is an integral part of the base. This Kovar ring is heated by induction from an RF oscillator.

The bulb of the HC-(XM-4)/U holder is designed to be evacuated through the cylindrical open end of the bulb. Heat is applied to the seal area by a closely controlled flame. Working of the seal is accomplished only by a "push" from the differential in room air pressure and the evacuated enclosure itself. After the actual glass-to-glass seal has been completed and flame annealed, the cullet end of the bulb is removed by sawing with an abrasive saw.

5. GLASS WORKING AND SEALING (Continued)

5.4. As described in Paragraph 4.1.6., sealing of pre-production samples was done in equipment developed by Philips Electronics Industries, Limited, and owned by the United States Government. For the benefit of those who may not be familiar with the work previously done by Philips Electronics Industries, Limited, permission has been obtained to reproduce portions of their report here. The publication to be quoted in this section is entitled, "RG-1, Glass Evacuated Crystal Holder - Sealing Information And Equipment", published by Canadian Radio Manufacturing Corporation, Limited, Toronto, Ontario, CANADA (now known as Philips Electronics Industries, Limited). This booklet describes a holder similar to the HC-(XM-2)/U.

5.4.1. The balance of Section 5.4. including figures, is extracted from the Philips work. Editorial modifications were made for reader clarity.

5.4.2. Processing Principles

5.4.2.1. General Requirements Of Glass Holder
Crystal Sealer

The requirements of the sealing device include:

- a. Sealing must be carried out in vacuum or inert gas to eliminate the need of a tip-off.

5. GLASS WORKING AND SEALING (Continued)

5.4. (Continued)

5.4.2. Processing Principles (Continued)

5.4.2.1. General Requirements Of Glass Holder
Crystal Sealer (Continued)

- b. Temperature of quartz crystal must be kept below 200 degrees Centigrade.
- c. Sealing program must be carefully controlled so that the preheat, sealing and annealing schedule can be reproduced.
- d. Proper alignment of bulb and base must be guaranteed.
- e. Controlled pressure must be applied between bulb and base during sealing.
- f. Outside dimensions must be kept within the specified tolerances during sealing.
- g. Vacuum pumps must have sufficient capacity to ensure satisfactory ultimate vacuum.
- h. Facilities must be provided to bake out the units during evacuation at a temperature of 150 degrees Centigrade.

5. GLASS WORKING AND SEALING (Continued)

5.4. (Continued)

5.4.2. Processing Principles (Continued)

5.4.2.1. General Requirements Of Glass Holder
Crystal Sealer (Continued)

- i. The equipment must be such that it can be operated by an inexperienced operator.
- j. The production rate must be as high as possible consistent with the quality of the seal.

5.4.2.2. Mechanics Of The Sealing Operation

An RF sealing method is employed in which the seal between bulb and base is made by heating a glazed metal ring which fits between the two. In this way, it is possible to seal the bulb and base under vacuum and still maintain the plated quartz blank at a low temperature. The sealing operation is carried out on the machine outlined in Figures 3 and 4. The twelve sealing heads are indicated together with the load, evacuation, oven and sealing positions. Descriptions and drawings of

5. GLASS WORKING AND SEALING (Continued)

5.4. (Continued)

5.4.2. Processing Principles (Continued)

5.4.2.2. Mechanics Of The Sealing Operation
(Continued)

the sealing head, vacuum equipment heating fixture and heat programming device are given in the following sections.

5.4.2.3. Operation Of The Sealing Head

The operation of the sealing head assembly is shown in Figures 5 and 6.

The sealing head assemblies are attached rigidly to the rotating table. Vacuum connection to each is made as described in Section 5.4.3.3. The sealing head assembly is constructed so that by turning the ejector lever, the bulb holder lowers and tilts forward into the loading position. While in this position, the bulb is placed in the bulb holder and the base with the sealed-on glazed metal ring is placed on the bulb. A ceramic retaining plate is placed over

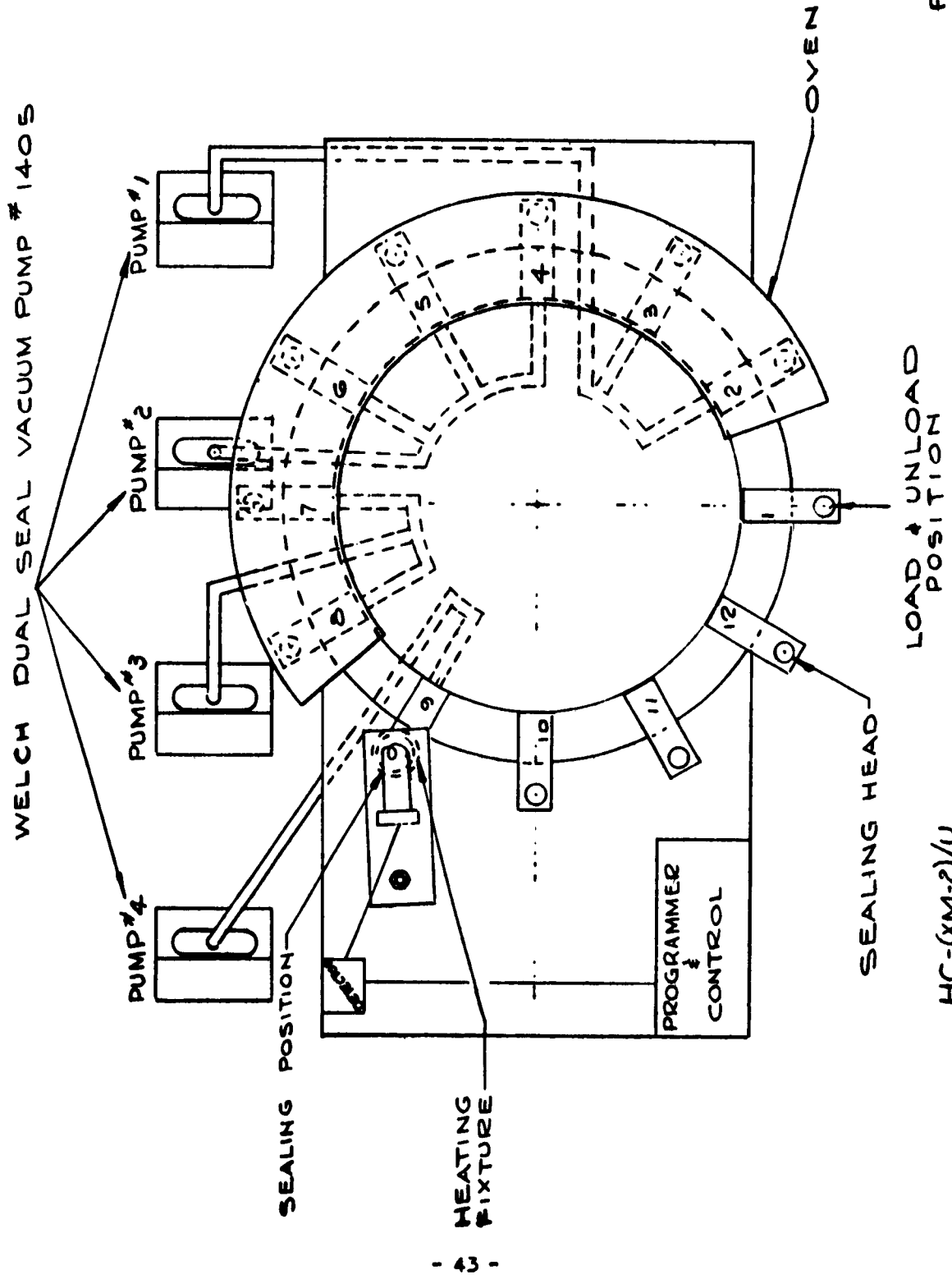

HC-(XM-2)/U
CRYSTAL SEALER

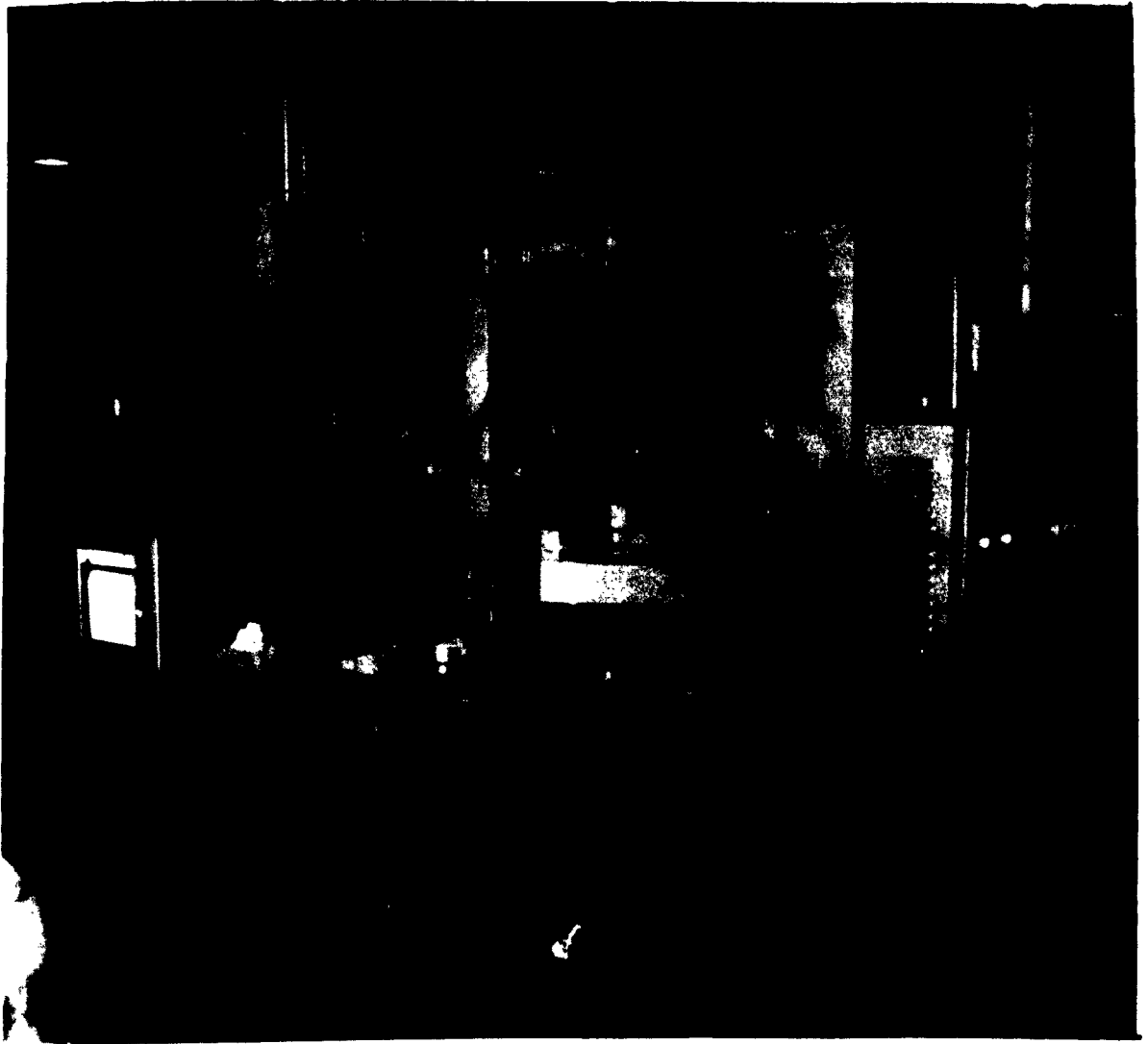

OPERATION OF SEALING HEAD

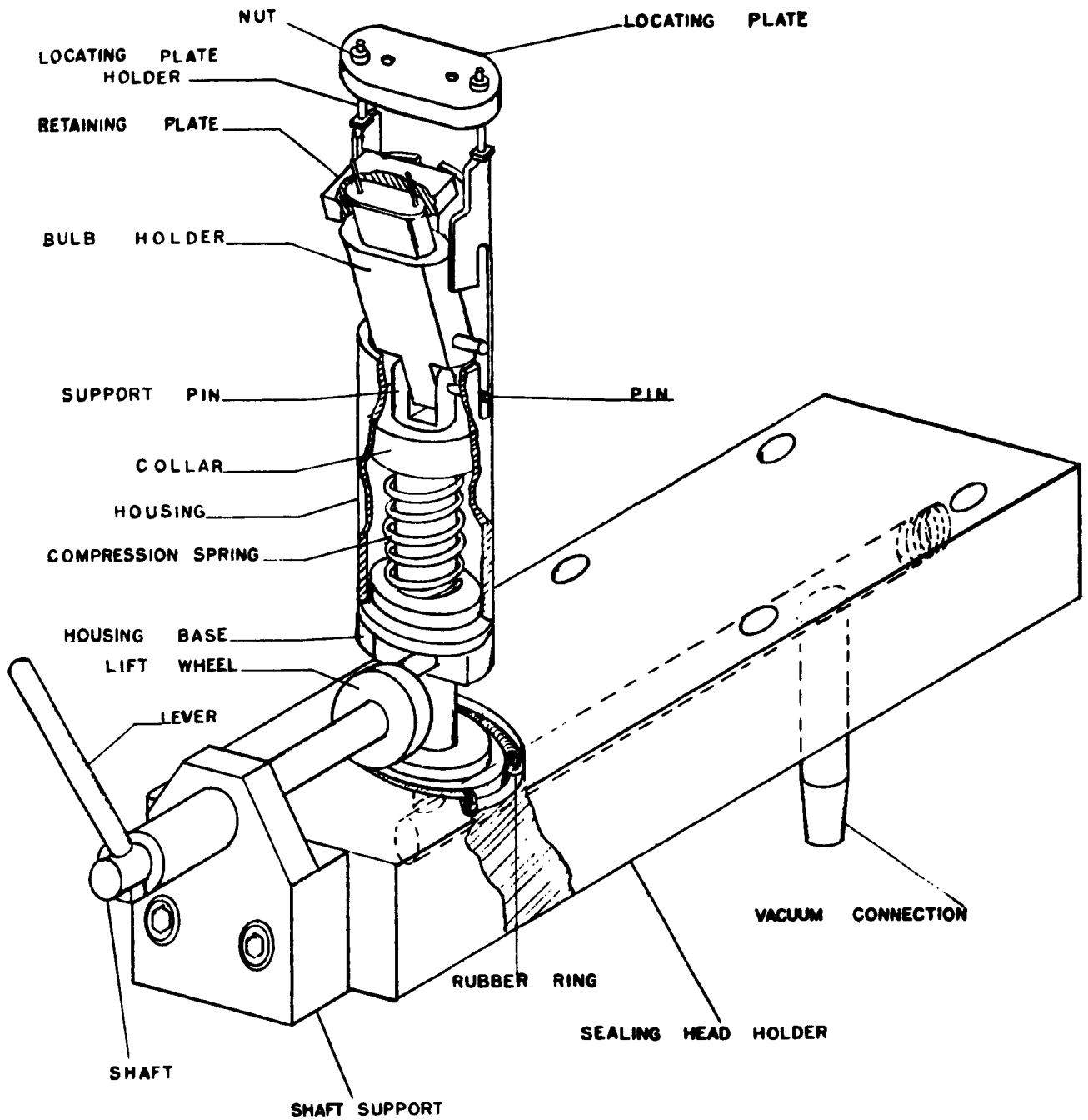



5. GLASS WORKING AND SEALING (Continued)

5.4. (Continued)

5.4.2. Processing Principles (Continued)

5.4.2.3. Operation Of The Sealing Head (Continued)

the base to ensure that the dimensions of the sealed unit satisfy the specified dimensions. When the ejector lever is turned back, the loaded bulb holder returns to a vertical position, rises and presses against the ceramic locating plate, under spring pressure. The position of the bulb holder and the locating plate guarantee the alignment of the bulb and base.

When the bulb holder is in the sealing position and the ejector lever is retracted, a bell jar is placed over the sealing head assembly. The ground surface of the bell jar seals on a rubber O-ring fitted in the base plate. The top of the bell jar is shaped so that the concentrator in the RF coil can be placed as close as possible to the metal sealing ring.

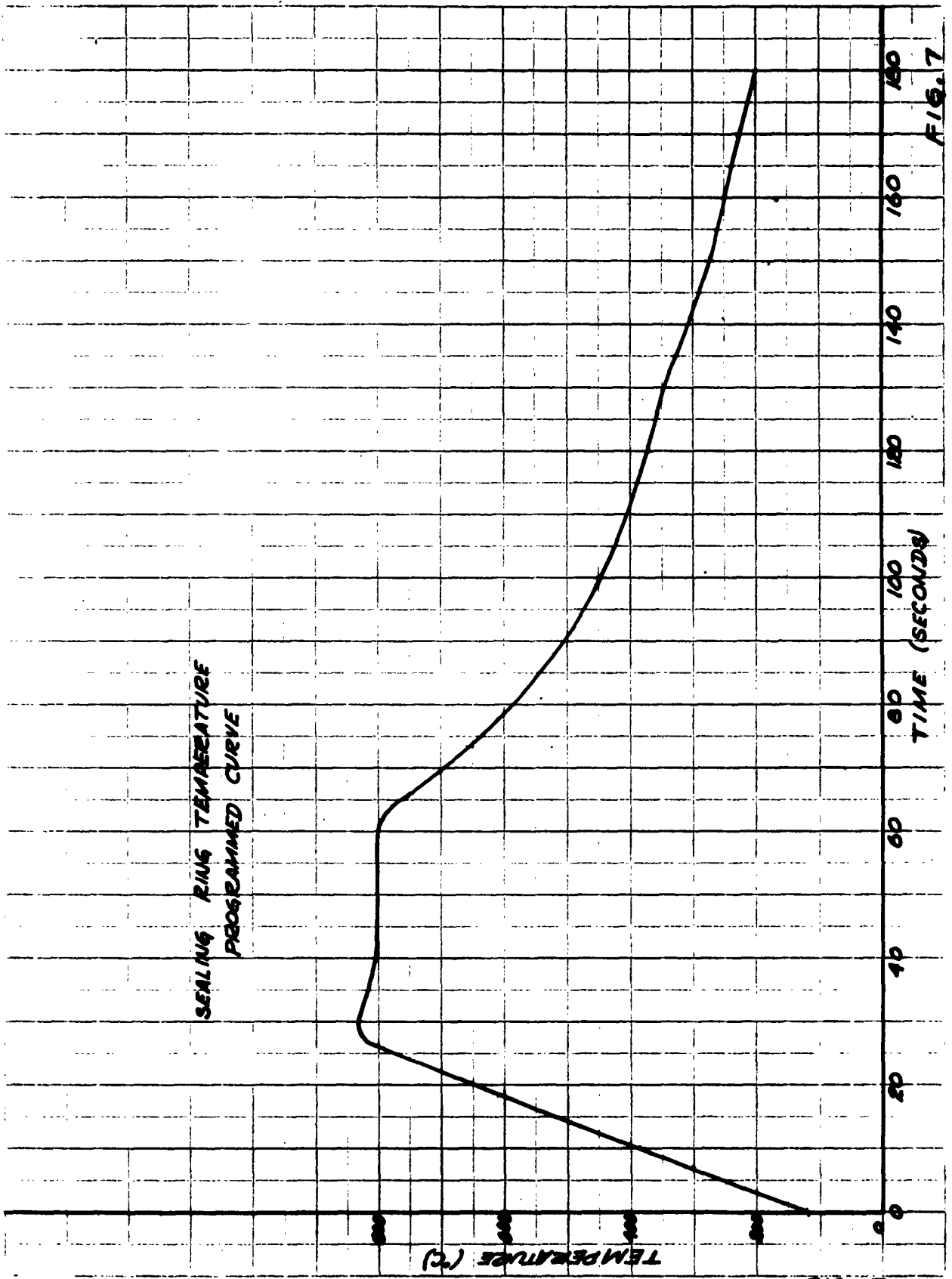

FIG. 7

TEMPERATURE (°C)

TIME (SECONDS)

SEALING RING TEMPERATURE
PROGRAMMED CURVE

5. GLASS WORKING AND SEALING (Continued)

5.4. (Continued)

5.4.2. Processing Principles (Continued)

5.4.2.4. Sealing Cycle

The sealing cycle must be carefully controlled to obtain a satisfactory preheat, sealing and annealing schedule. A typical variation of temperatures of the metal sealing ring during the sealing operation is shown in Figure 7. The temperature increases slowly to a maximum temperature of 840 degrees Centigrade, decreases slowly due to conduction cooling during sealing, and then decreases gradually to a temperature of approximately 200 degrees Centigrade. This temperature cycle is completed in a period of three minutes. The unit is allowed to cool in vacuum for a period of three minutes and in air for a period of six minutes before it is removed from the sealing assembly.

5.4.2.5. Pre-Sealing Treatment Of Holder Parts

As the HC-(XM-2)/U holder parts are made of glass, cleaning problems are reduced. The inside of the bulb is brushed free of dirt with a nylon brush and then scrubbed

5. GLASS WORKING AND SEALING (Continued)

5.4. (Continued)

5.4.3. Sealing Machine Descriptive Information (Continued)

5.4.3.1. Sealing Machine (Continued)

twelve sealing heads and one induction heating coil are used. One crystal unit can be sealed for each index of the machine.

The time in the rest position can be varied up to a period of ten minutes. However, three minutes has been determined as the minimum time required to obtain a satisfactory seal. During this time the preheat sealing and annealing occur. The time required between rest positions is fifteen seconds. Hence, the machine equipped with twelve sealing heads gives an output of eighteen sealed units per hour.

To increase production, more sealing heads up to a maximum total of four can be added to each rest position.

The vacuum connections are described in Section 5.4.3.3. A bake out oven is mounted over Pumping Positions 2 to 8.

5. GLASS WORKING AND SEALING (Continued)

5.4. (Continued)

5.4.3. Sealing Machine Descriptive Information (Continued)

5.4.3.1. Sealing Machine (Continued)

In this way the units can be baked out at a temperature of 150 degrees Centigrade during evacuation.

5.4.3.2. Sealing Heads

The operation of the sealing head has been described in Section 5.4.2.3. The assembly drawing and various details are given in the drawings found in Appendix under SK-1-59-D-1 through SK-1-59-D-28 inclusive.

5.4.3.3. Vacuum Equipment

Satisfactory evacuation is achieved by means of four Welch Duo-Seal two-stage high vacuum pumps, Model No. 1405. Each sealing position is connected to the center rotating vacuum valve through a shut-off valve and glass oil trap. The shut-off valve can be used to isolate each head from the vacuum system in case of emergency. The pumps are connected as shown in Figure 3.

5. GLASS WORKING AND SEALING (Continued)

5.4. (Continued)

5.4.3. Sealing Machine Descriptive Information (Continued)

5.4.3.3. Vacuum Equipment (Continued)

The units are rough pumped in Positions 2 and 3 (Vacuum Pump 1). The second pump is used on Positions 4, 5 and 6. The third pump operates on Positions 7 and 8. The fourth vacuum pump is used on the sealing position, Position 9, in order to obtain a high pumping speed during the sealing operation.

The center rotating valve is plugged in Position 10 so that the bell jar remains under vacuum although not connected to a vacuum pump. This aids in annealing the unit as it cools while under vacuum.

In Positions 11 and 12 the bell jar is opened to the atmosphere so the unit is cool enough to handle in Position 1.

The vacuum in the bell jar measured in the various rest positions by means of a McLeod gauge gave the following results:

5. GLASS WORKING AND SEALING (Continued)

5.4. (Continued)

5.4.3. Sealing Machine Descriptive Information (Continued)

5.4.3.3. Vacuum Equipment (Continued)

<u>Position</u>	<u>Pressure (Microns Of Hg)</u>
2, 3	75
4, 5, 6	30
7, 8	25
9 during sealing	75

5.4.3.4. Heating Fixture

The RF coil is formed from copper tubing covered with glass insulation. Water is supplied to the coil by means of flexible rubber tubing. The rate of flow is maintained at approximately 0.3 gallons per minute. See Figure 8.

A concentrator in the form of a split copper cylinder with an end plate fits inside the coil. The end plate has an opening which fits the outside top dimension of the bell jar. This concentrates the heat in the area of the metal sealing ring. The concentrator has been rigidly mounted since its position is critical. The concentrator is air cooled to prevent changes in its characteristics with heat.

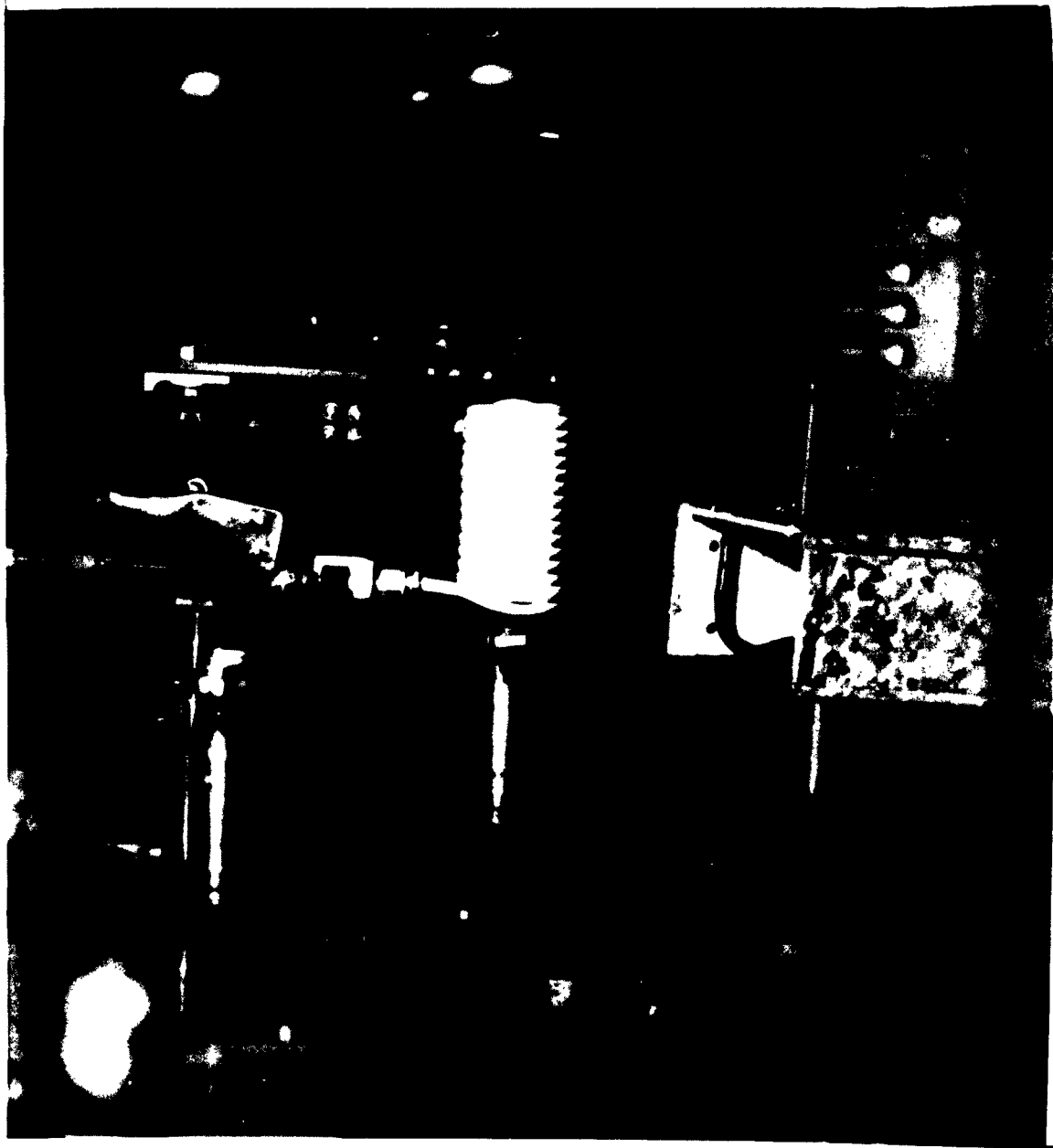

5. GLASS WORKING AND SEALING (Continued)

5.4. (Continued)

5.4.3. Sealing Machine Descriptive Information (Continued)

5.4.3.4. Heating Fixture (Continued)

The RF oscillator employed to supply power to the induction heating coil in the present setup is a Philips Type No. E.4 385 09 rated at 8 KW, 200 amps. and designed to operate on 380 volts, 50 cycles. Since the output of this apparatus is much more than is required, it has been modified to operate on 220 volt, 3 phase, 60 cycle. A sensing coil consisting of three turns of copper rod is mounted rigidly above the work coil support.

The coil assembly is raised and lowered by means of a cam on the main drive shaft of the machine.

5.4.3.5. Heat Programming Device

The induction heating required for the sealing operation must be regulated and programmed. To accomplish both these operations a servo-loop is employed together with a cam driven reference

5. GLASS WORKING AND SEALING (Continued)

5.4. (Continued)

5.4.3. Sealing Machine Descriptive Information (Continued)

5.4.3.5. Heat Programming Device (Continued)

voltage. A block diagram of this equipment is shown in Figure 9. The function of the various units is described below.

a. Work Coil

The induction heater work coil surrounds a specially designed concentrator as described in Section 5.4.3.4. The concentrator localizes the heat in the area of the metal sealing ring.

b. Sensing Coil

Immediately above the work coil is the sensing coil. The pick up on this coil is proportional to the field in the work coil.

c. Detector

Mounted immediately behind the work and sensing coils and connected to them by flexible leads is a box containing the detector circuit. This consists of a selenium

BLOCK DIAGRAM OF CRYSTAL SEALER CONTROLLER

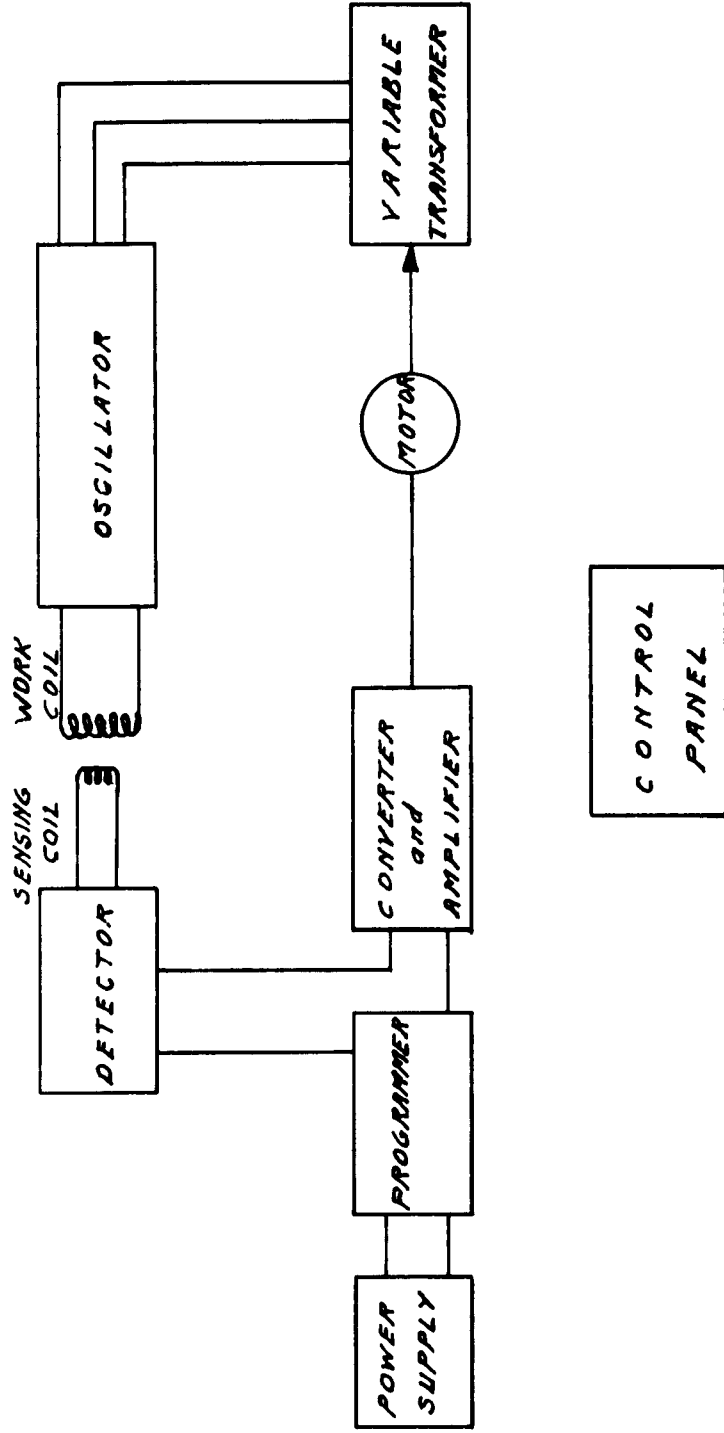

FIG. 9

5. GLASS WORKING AND SEALING (Continued)

5.4. (Continued)

5.4.3. Sealing Machine Descriptive Information (Continued)

5.4.3.5. Heat Programming Device (Continued)

c. Detector (Continued)

rectifier and associated filter circuitry for converting a portion of the R F. signal to a D.C. value. The output signal is built up across the 10 ohm resistor in Figure 10.

d. Programmer

The three-minute work cycle is programmed by a synchronous motor driving a specially designed cam. By means of a rocker arm system the radial variations of the cam are transmitted as angular motion to a potentiometer. A programmed reference voltage is thus obtained from the slides of the potentiometer. A limit switch is provided to synchronize this cycle with that of the rotating table.

5. GLASS WORKING AND SEALING (Continued)

5.4. (Continued)

5.4.3. Sealing Machine Descriptive Information (Continued)

5.4.3.5. Heat Programming Device (Continued)

e. Reference Voltage Power Supply

To maintain the reference voltage independent of supply variations, a regulated power supply is provided. This consists of a normal rectifier circuit followed by an OA2 voltage regulator. To assure the utmost in stability this is followed by an OG3 voltage reference tube.

f. Converter And Amplifier

The difference in voltage between the programmer output and the detector output is fed to the Brown converter and amplifier unit, No. 356358-1. This unit converts the difference or error signal to 60 cycle A C. and amplifies it sufficiently to drive the servo motor. The phase of the output relative to the 60 cycle line depends on the polarity of the

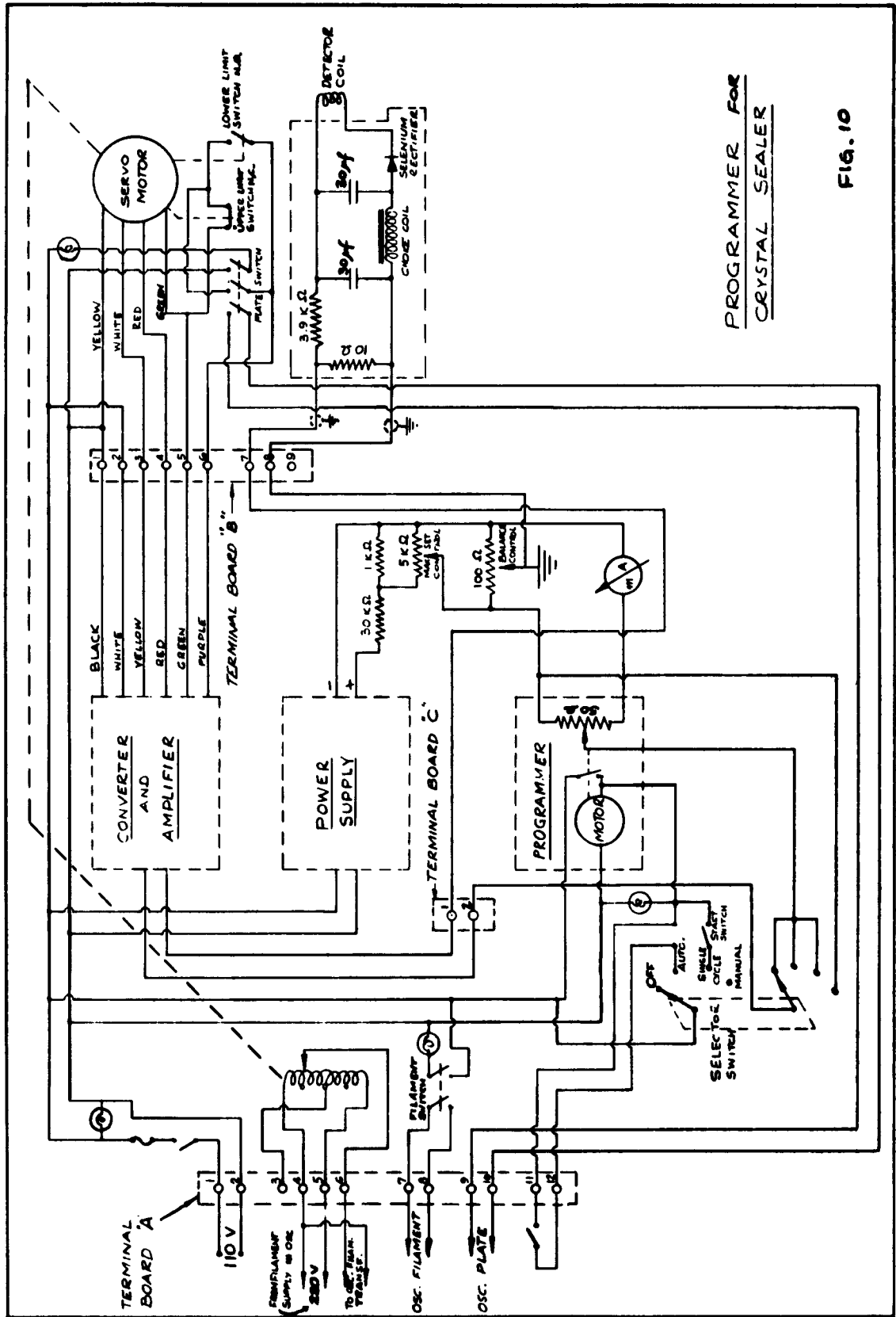

PROGRAMMER FOR
CRYSTAL SEALER

FIG. 10

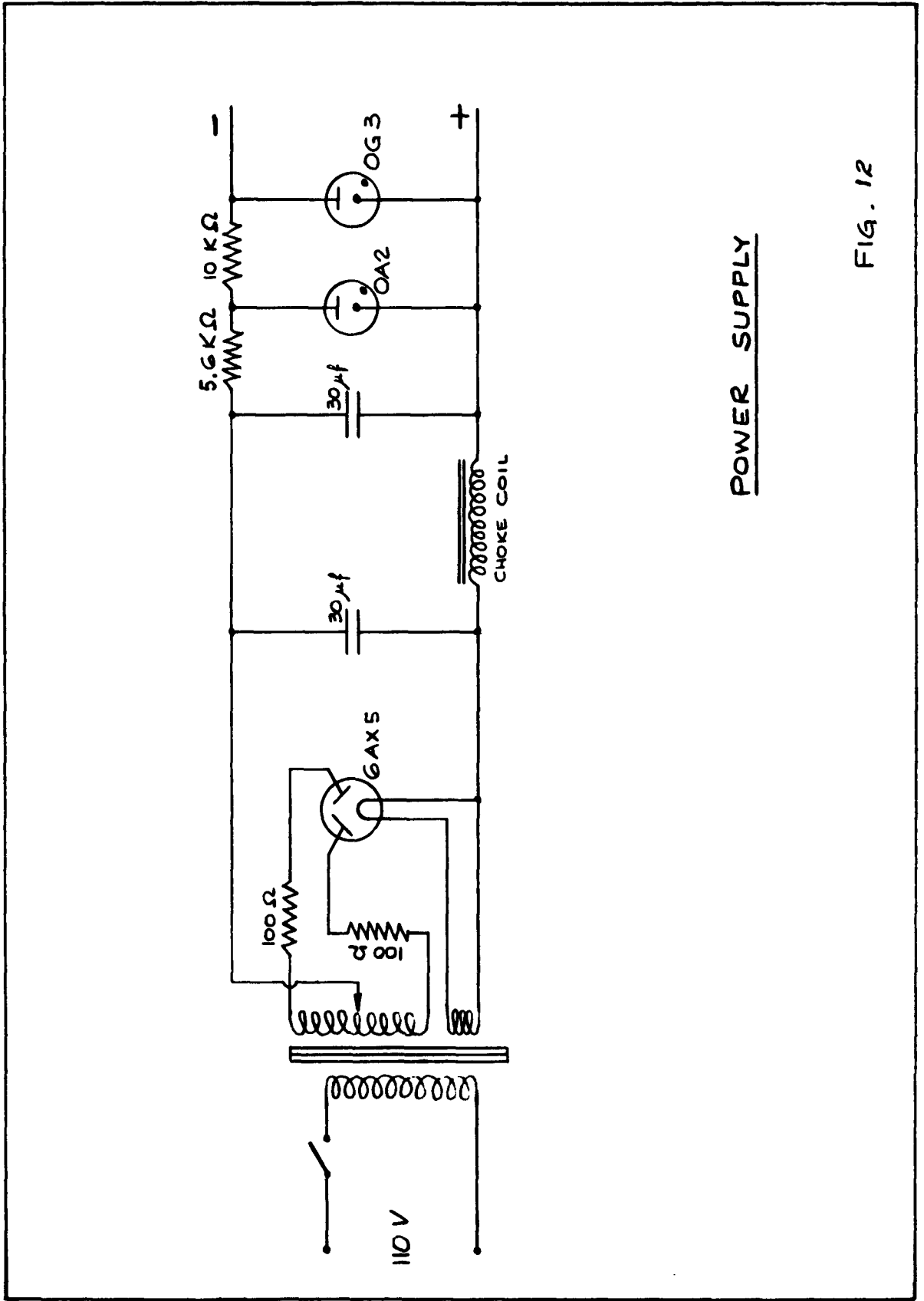

POWER SUPPLY

FIG. 12

5. GLASS WORKING AND SEALING (Continued)

5.4. (Continued)

5.4.3. Sealing Machine Descriptive Information (Continued)

5.4.3.5. Heat Programming Device (Continued)

f. Converter And Amplifier (Continued)

error signal and the direction of the servo motor rotation depends on this phase. The gain of this amplifier is adjustable by means of a slotted shaft recessed in the top of this chassis.

g. Servo Motor And Power Controller

The servo motor is geared to a variable transformer. This transformer has a maximum rating of 9 amps at 220 volts. This system has been designed to control the induction heating unit by varying the filament voltage of the oscillator tube. The gear train between the motor and variable transformer has been designed to minimize overshoot due to the thermal lag inherent in such a control system. If plate supply control

5. GLASS WORKING AND SEALING (Continued)

5.4. (Continued)

5.4.3. Sealing Machine Descriptive Information (Continued)

5.4.3.5. Heat Programming Device (Continued)

g. Servo Motor And Power Controller

(Continued)

is provided for in the induction heater, then the servo motor may be geared to this control. In this case, the response time will be limited by the torque available from the servo motor. The motor is rated at 30 inch ounces and 20 R.P.M.

h. Induction Heating Oscillator

The oscillator employed in the present set-up is described in Section 5.4.3.4.

i. Control Panel

The circuit diagrams for the control system are shown in Figures 10, 11 and 12. Filament switch, plate supply switch and indicator lights are provided for the oscillator. The control system is designed to obtain its

5. GLASS WORKING AND SEALING (Continued)

5.4. (Continued)

5.4.3. Sealing Machine Descriptive Information (Continued)

5.4.3.5. Heat Programming Device (Continued)

i. Control Panel (Continued)

power from the oscillator to insure interlocking of the control system. As a safety feature, the variable transformer runs to zero when the plate supply is turned off. A selector switch determines the mode of operation. In the automatic position, the programmer is started by the rotation of the sealing table.

In the single cycle position, momentarily pressing of the start button will program a single cycle. In the manual position the oscillator power may be controlled by the panel control. A meter is provided for accurate indication of the reference setting. In the automatic position, the meter indicates the

5. GLASS WORKING AND SEALING (Continued)

5.4. (Continued)

5.4.3. Sealing Machine Descriptive Information (Continued)

5.4.3.5. Heat Programming Device (Continued)

i. Control Panel (Continued)

maximum reference setting. In the manual position, the meter indicates the actual reference setting. A screw adjustment is provided for balancing the system at the minimum power end. Operation of the programmer is indicated by a separate panel light. The panel control adjusts the maximum reference voltage in the automatic and single cycle positions and the actual reference voltage in the manual position.

Typical programmed oscillator characteristics are shown in Figures 13, 14, and 15. These include filament voltage, plate current and load current variations for the three minute sealing period.

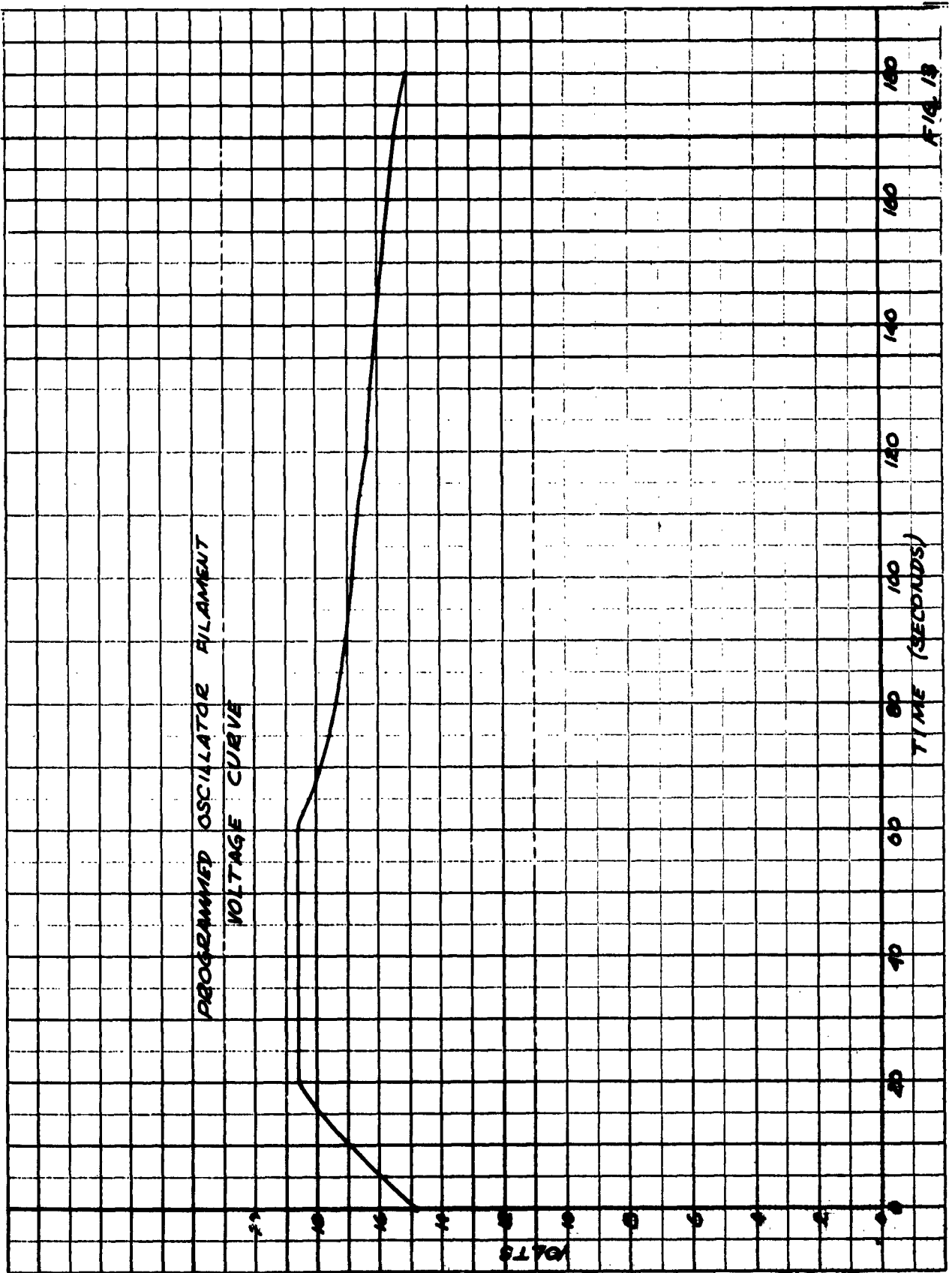

FIG. 13

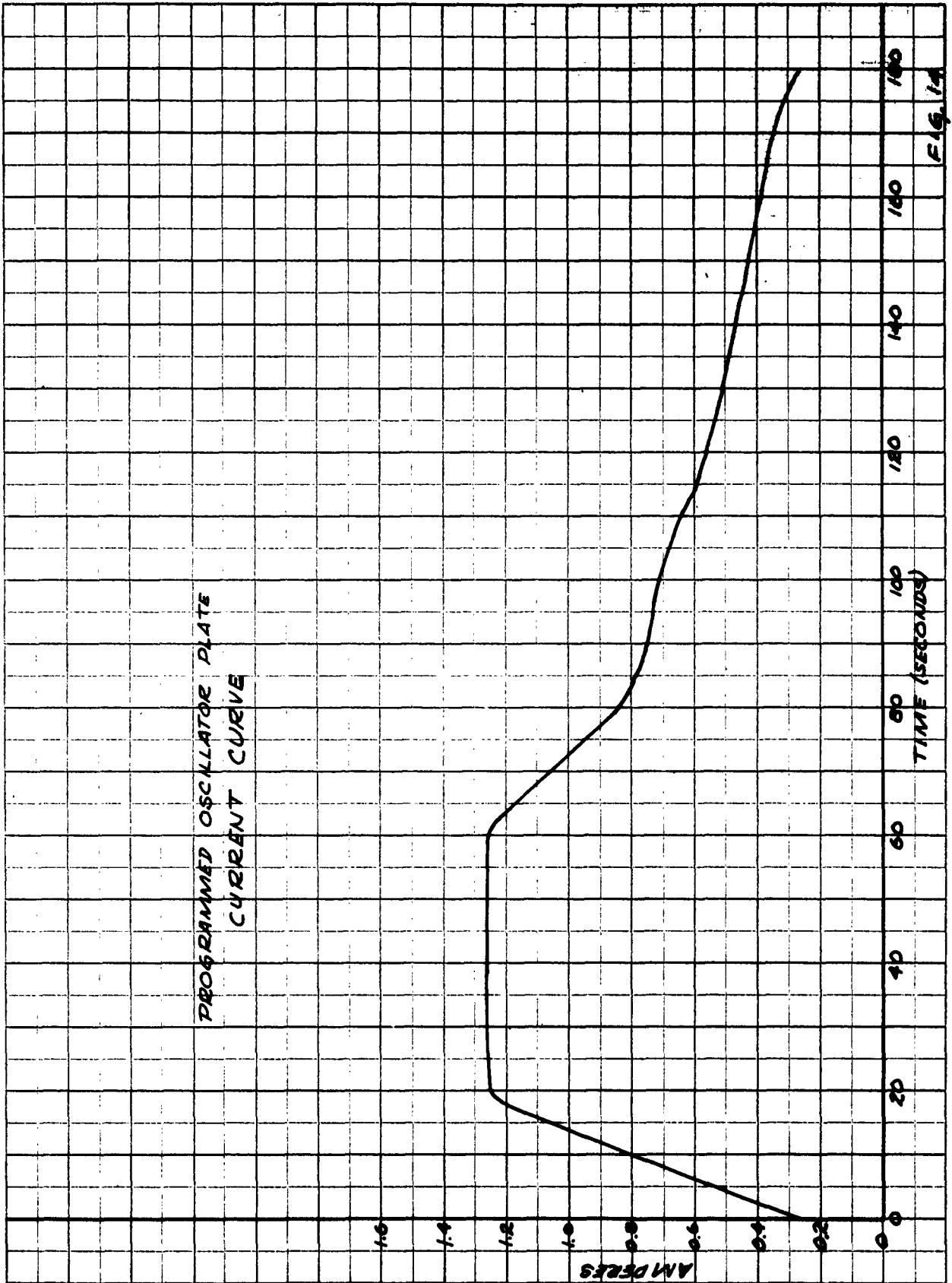
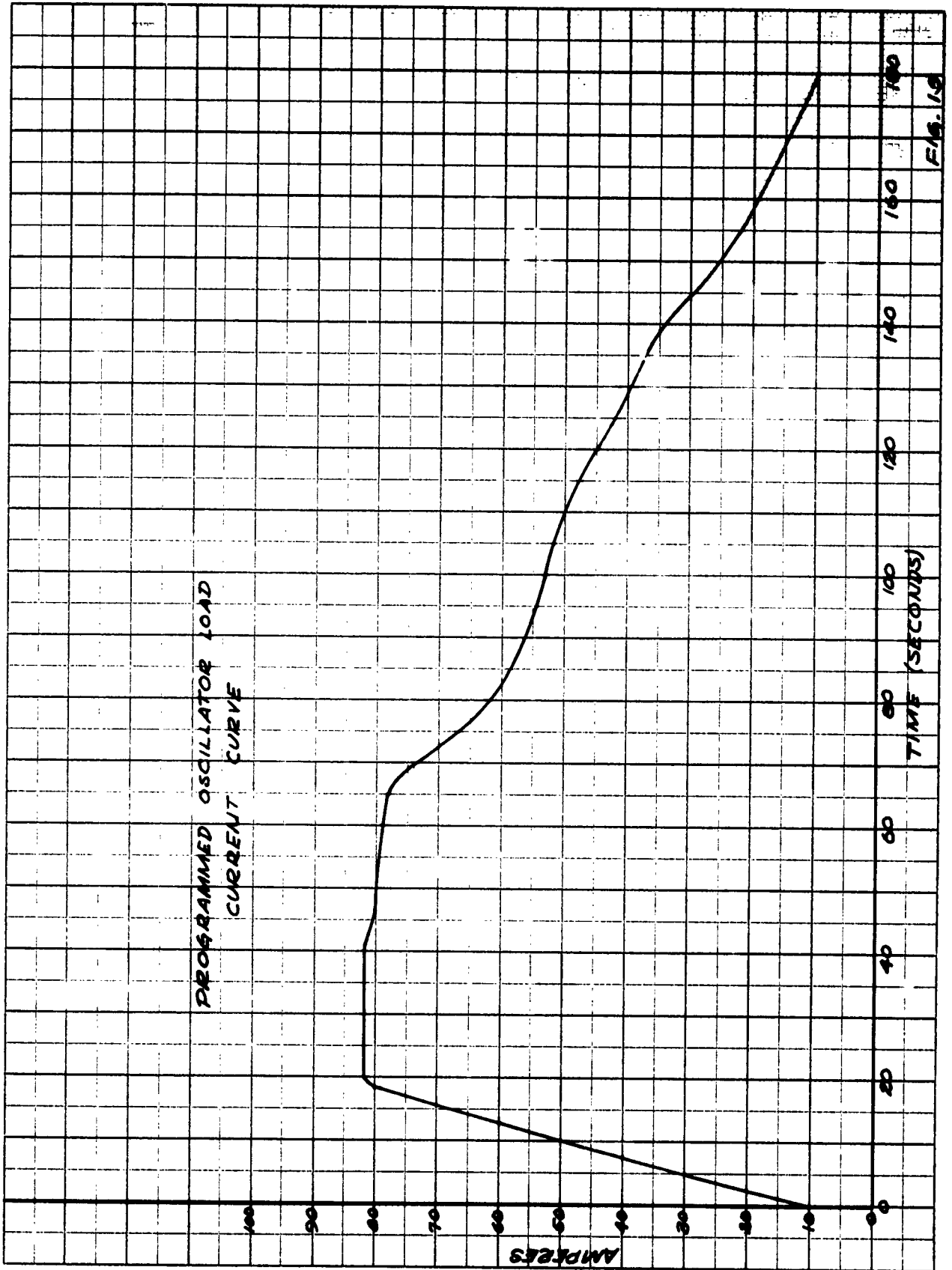

FIG. 14

FIG. 14



PROGRAMMED OSCILLATOR LOAD
CURRENT CURVE

AMPERES

TIME (SECONDS)

F/16.15

FIG. 15

5. GLASS WORKING AND SEALING (Continued)

5.4. (Continued)

5.4.3. Sealing Machine Descriptive Information (Continued)

5.4.3.6. Installation

5.4.3.6.1. Sealing Machine

The required services for the sealing machine are:

a. Electrical supplies

220 volt 3 phase

60 cycle 30 amps

110 volt

60 cycle 25 amps

b. Water feed 20 gallons per hour

c. An inductive heating

unit of approximately

5 KW rating is required

with suitable electrical

and water supplies.

5.4.3.6.2. R.F. Oscillator

The control system for the crystal sealer is designed

for an induction heater

which employs 220 volts,

60 cycle in its control

system. If higher voltages

5. GLASS WORKING AND SEALING (Continued)

5.4. (Continued)

5.4.3. Sealing Machine Descriptive Information (Continued)

5.4.3.6. Installation (Continued)

5.4.3.6.2. R.F. Oscillator (Continued)

are employed, then two additional relays and two auto transformers will be required.

Install the oscillator unit as close to the sealer as possible. Connect control lines to oscillator as indicated in Figure 10. Terminal Strip A may be reached by opening the control box beneath the sealer. Connect R.F. lines to output of oscillator. If possible, obtain water supply for work coil through oscillator water pressure interlock. Adjust flow rate to 0.3 gallons per minute.

5. GLASS WORKING AND SEALING (Continued)

5.4. (Continued)

5.4.3. Sealing Machine Descriptive Information (Continued)

5.4.3.7. Setting-Up Instructions

5.4.3.7.1. Single Cycle Operation

- a. Rotate sealer table and stop with work coil between heads.
- b. Pull out control chassis and remove cover.
- c. Replace control chassis without cover in such a manner that rotation of variable transformer may be observed.
- d. Turn on water for oscillator and load coil.
- e. Set selector switch to manual and if programmer light comes on, wait until it extinguishes.
- f. Set setting control to minimum.
- g. Turn on programmer switch and oscillator heater switch. (Plate switch off.)

5. GLASS WORKING AND SEALING (Continued)

5.4. (Continued)

5.4.3. Sealing Machine Descriptive Information (Continued)

5.4.3.7. Setting-Up Instructions (Continued)

5.4.3.7.1. Single Cycle Operation

(Continued)

- h. After short warm-up, variable transformer should turn to low end and oscillate slowly. If balance control is out of adjustment, there will be no oscillation.
- i. Adjust balance control for point where oscillation is just noticeable.
- j. Turn on plate switch and adjust balance control so that variable transformer moves very slowly, clockwise. This must be done before oscillator starts to indicate load current. If adjustment is not completed before

5. GLASS WORKING AND SEALING (Continued)

5.4. (Continued)

5.4.3. Sealing Machine Descriptive Information (Continued)

5.4.3.7. Setting-Up Instructions (Continued)

5.4.3.7.1. Single Cycle Operation

(Continued)

j. (Continued)

this occurs, turn off plate switch. As soon as variable transformer has turned to low end, repeat Step j.

k. When Step j. has been completed, the variable transformer should rotate clockwise and finally stop at the point where load current is just apparent.

l. Slowly increase the setting control. The oscillator output will follow. Set at 50 amps load current.

5. GLASS WORKING AND SEALING (Continued)

5.4. (Continued)

5.4.3. Sealing Machine Descriptive Information (Continued)

5.4.3.7. Setting-Up Instructions (Continued)

5.4.3.7.1. Single Cycle Operation

(Continued)

- m. Adjust the amplifier gain control (inside control box on top of amplifier) to just below the point at which rapid heating occurs. Return setting control to zero.
- n. Start pumps and obtain a vacuum in sealing position better than 25 microns of mercury.
- o. Load unit with bases and bulbs and rotate into sealing position.
- p. Slowly advance setting control until temperature is 810 degrees Centigrade. Do not leave setting control in this high position for longer

5. GLASS WORKING AND SEALING (Continued)

5.4. (Continued)

5.4.3. Sealing Machine Descriptive Information (Continued)

5.4.3.7. Setting-Up Instructions (Continued)

5.4.3.7.1. Single Cycle Operation

(Continued)

- p. (Continued)
than thirty seconds.
Repeat at one minute intervals if necessary to get setting for correct temperature.
- q. Turn selector switch to single cycle and set setting control for the 810 degrees Centigrade maximum setting obtained in Step p.
- r. Rotate a new unit into position and turn off table control.
- s. Press start button and hold until programmer light remains lit when recleared. Oscillator should program as indicated in Figure 14.

5. GLASS WORKING AND SEALING (Continued)

5.4. (Continued)

5.4.3. Sealing Machine Descriptive Information (Continued)

5.4.3.7. Setting-Up Instructions (Continued)

5.4.3.7.1. Single Cycle Operation

(Continued)

- t. After approximately three minutes, programmer light will go out and table may be rotated.
- u. Leave head containing sealed unit in cooling position under vacuum for at least three minutes, before rotating to loading position.
- v. Replace cover on control box and place unit in proper position. Once satisfactory seals have been obtained in the single cycle position, automatic operation may be initiated.

5. GLASS WORKING AND SEALING (Continued)

5.4. (Continued)

5.4.3. Sealing Machine Descriptive Information (Continued)

5.4.3.8. Operating Instructions

5.4.3.8.1. Sealing Machine

- a. Turn selector switch to "Off".
- b. Turn on controller and set setting control to value obtained in Step p.
- c. Start vacuum pump oven and oscillator filament.
- d. Set table timer for 3.05 minutes or more and start.
- e. Load crystal units as table passes loading position.
- f. When first crystal unit rotates into the position immediately before the sealing position, turn selector switch to automatic and turn on plate voltage.

5. GLASS WORKING AND SEALING (Continued)

5.4. (Continued)

5.4.3. Sealing Machine Descriptive Information (Continued)

5.4.3.8. Operating Instructions (Continued)

5.4.3.8.1. Sealing Machine (Continued)

f. (Continued)

Be sure table has stopped before turning switches.

It is important that the programmer does not operate on empty heads.

- g. While the last crystal is being sealed, turn selector switch to "Off".

5.4.3.8.2. Crystal Loading

- a. Remove glass bell jar.
- b. Open sealing head to loading position, turning handle counterclockwise.
- c. Place bulb in bulb holder.
- d. Place base assembly onto bulb.
- e. Place ceramic retaining plate over base.

5. GLASS WORKING AND SEALING (Continued)

5.4. (Continued)

5.4.3. Sealing Machine Descriptive Information (Continued)

5.4.3.8. Operating Instructions (Continued)

5.4.3.8.2. Crystal Loading (Continued)

- f. Raise sealing head into sealing position by turning handle clockwise.
- g. Place bell jar over sealing head.

5.4.4. Sealing Process Fault Location And Correction

A table of the more common faults which may occur in sealed crystal units are listed below together with their causes. Included also are the adjustments which should be made to the sealing machine when these faults occur in excessive proportions.

5.4.4.1. Crystal Characteristics

- a. Fault: Frequency increases
Cause: Overheating
Correction: Reduce power input to heating fixture.

5. GLASS WORKING AND SEALING (Continued)

5.4. (Continued)

5.4.4. Sealing Process Fault Location And Correction

(Continued)

5.4.4.1. Crystal Characteristics (Continued)

b. Fault: Frequency decreases

Cause: Contamination from handling
or sealing machine

Correction: Improve cleanliness
of one or more of
the following: sealing
jig, bell jar, holder
parts.

Cause: Decomposition of cement

Correction: Reduce amount of
cement and ensure
proper curing.

c. Fault: Quartz develops high
resistance or refuses to
oscillate. (Silver base
coat may have become
yellowish or translucent.)

Cause: Severe overheating

Correction: Reduce power to heating
fixture.

5. GLASS WORKING AND SEALING (Continued)

5.4. (Continued)

5.4.4. Sealing Process Fault Location And Correction
(Continued)

5.4.4.1. Crystal Characteristics (Continued)

c. (Continued)

Cause: Blank mounted too low in holder. Blank mounted too high in holder resulting in clamping.

Correction: Raise blank to position at least .050 inches above holder base.

5.4.4.2. Glass Defects

a. Fault: Cracks starting from the base seal during sealing or later during temperature cycling, or leaky base seal

Cause: Underheating

Correction: Increase power to heating fixture,

5. GLASS WORKING AND SEALING (Continued)

5.4. (Continued)

5.4.4. Sealing Process Fault Location And Correction
(Continued)

5.4.4.2. Glass Defects (Continued)

b. Fault: Poor vacuum

Cause: Defective holder parts

Cause: Excessive cement used

Correction: Reduce amount of
cement and ensure
proper curing.

Cause: Poor sealing machine
vacuum

Correction: Repair vacuum system.

5. GLASS WORKING AND SEALING (Continued)

- 5.5. The same sealing techniques as described in Paragraph 5.4. above were used for sealing the HC-(X4-3)/U holder. There is no need to be redundant.

5. GLASS WORKING AND SEALING (Continued)

5.6. As described in Paragraphs 4.1.6. and 5.4., sealing of pre-production samples was done on equipment developed by Philips Electronics Industries, Limited, and owned by the United States Government. Again, for the benefit of those who may not be familiar with the work previously done by Philips Electronics Industries, Limited, permission has been obtained to reproduce portions of their reports here. The publication to be quoted in this section is entitled: "RG-2, Glass Evacuated Crystal Holder - Sealing Information And Equipment", published by Canadian Radio Manufacturing Corporation, Limited, Toronto, Ontario, CANADA, now known as Philips Electronics Industries, Limited. This booklet describes a holder similar to the HC-(XM-4)/U.

5.6.1. The balance of Section 5.6., including the figures, is extracted from the Philips' work. Editorial modifications were made for reader clarity.

5.6.2. Processing Principles

5.6.2.1. General Requirements Of A Glass Crystal Holder Sealing Machine

The requirements of the sealing device include:

- a. Sealing and pumping must be done simultaneously to eliminate the need of a tip-off.

5. GLASS WORKING AND SEALING (Continued)

5.6. (Continued)

5.6.2. Processing Principles (Continued)

5.6.2.1. General Requirements Of A Glass Crystal Holder Sealing Machine (Continued)

- b. Temperature of quartz crystal must be kept below 200 degrees Centigrade.
- c. Proper alignment of bulb and base must be ensured during sealing.
- d. Method should result in reproducible seals.
- e. Vacuum pump must have sufficient capacity to ensure satisfactory exhaust.
- f. The equipment should be such that it can be operated by a semi-skilled worker.
- g. The production rate must be as high as possible consistent with the quality of the seal.

5.6.2.2. Mechanics Of The Sealing Operation

A flame sealing method is employed in which the seal is made while the unit is being evacuated through an extension of the bulb. In this way it is possible to seal the bulb and base

5. GLASS WORKING AND SEALING (Continued)

5.6. (Continued)

5.6.2. Processing Principles (Continued)

5.6.2.2. Mechanics Of The Sealing Operation

(Continued)

leaving a vacuum in the unit and still maintain the plated quartz blank at a sufficiently low temperature. The arrangement which is used to carry out this method of sealing is shown in Figure 16.

The crystal blank is mounted on a glass base, the leads of which are inserted in a positioning jig. This accurately fixes the position of the base. The glass bulb, which in the area of the seal closely fits the shape of the base, is placed over the base assembly.

A vacuum tight connection is made to the vacuum system by means of the chuck.

After the unit has been pumped for some time and while it is still being evacuated, the bulb and base are sealed

HC-(XM-4)/U CRYSTAL SEALING METHOD

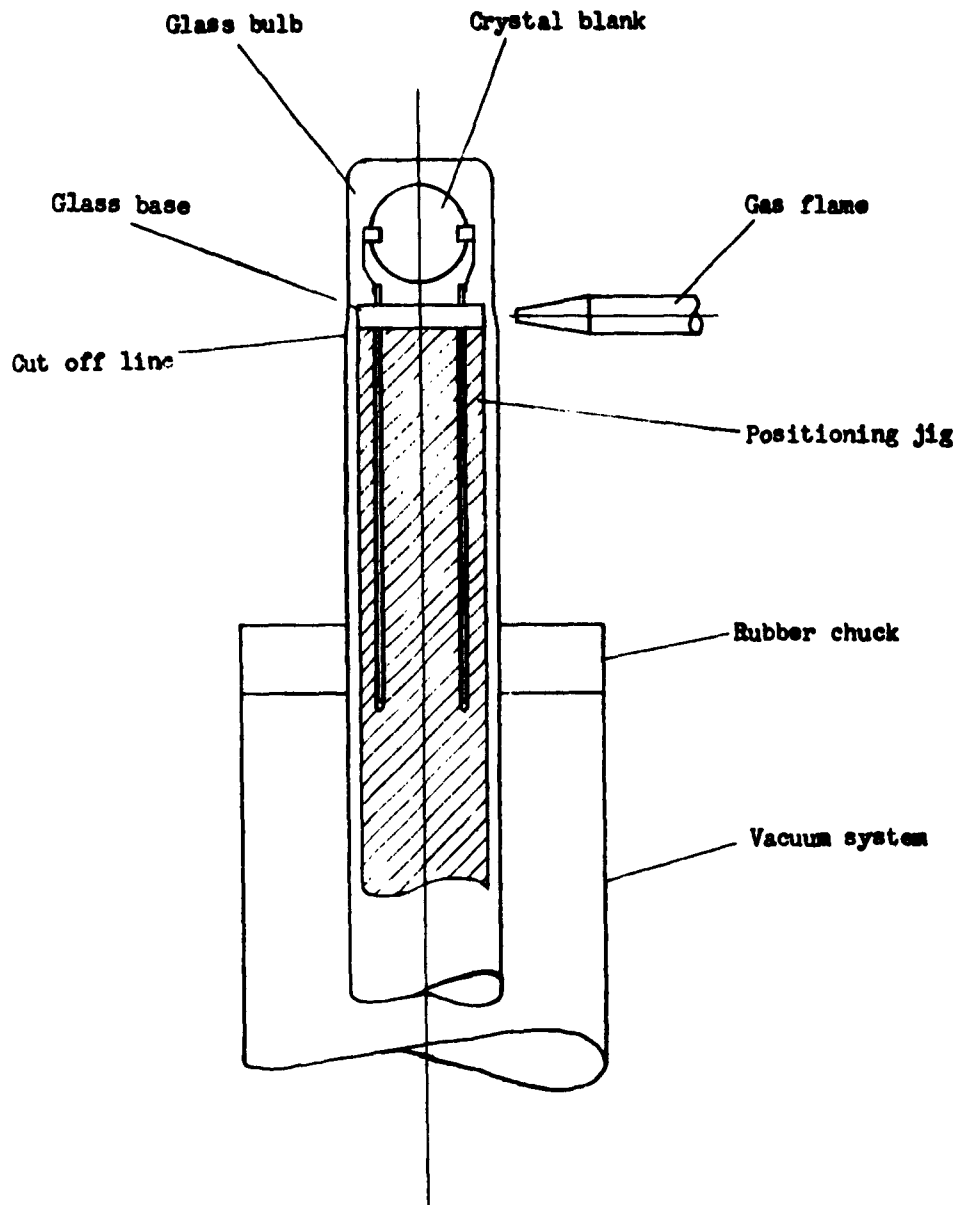

5. GLASS WORKING AND SEALING (Continued)

5.6. (Continued)

5.6.2. Processing Principles (Continued)

5.6.2.2. Mechanics Of The Sealing Operation
(Continued)

together by means of a gas flame. A very fine flame is employed which rotates around the seal area at a very slow rate. The flame support is pivoted so that the position of the flame relative to the seal can be controlled by means of a cam. The difference in pressure between the outside and inside of the bulb (1 atmosphere) causes the bulb to collapse onto the base at a temperature considerably lower than that required if no pressure difference existed. In this way a small length of seal is made at one time while the rest of the seal area is cool. With this method the crystal remains at a sufficiently low temperature and the relative position of the bulb and base is maintained.

5. GLASS WORKING AND SEALING (Continued)

5.6. (Continued)

5.6.2. Processing Principles (Continued)

5.6.2.2. Mechanics Of The Sealing Operation

(Continued)

After the seal has been completed, the unit is removed from the rubber chuck and the glass tubulation is removed. This leaves the evacuated glass enclosed crystal unit of dimensions which can be reproduced to close tolerances.

5.6.2.3. Pre-Sealing Treatment Of Holder Parts

As the HC-(XM-4)/U holder parts are made of glass, cleaning problems are reduced. The inside of the bulb is brushed free of dirt with a nylon brush and then scrubbed with pure alcohol and washed in three changes of boiling distilled water. The bases are cleaned in the same manner. The parts are dried in a vacuum oven at 150 degrees Centigrade for several hours.

5. GLASS WORKING AND SEALING (Continued)

5.6. (Continued)

5.6.2. Processing Principles (Continued)

5.6.2.3. Pre-Sealing Treatment Of Holder Parts

(Continued)

Vacuum bakeout at even higher temperatures up to the softening point of glass is suggested for all holder parts in order to remove absorbed contamination and gases.

After cleaning, holder parts are stored in a dry, dust-free atmosphere.

5.6.3. Sealing Machine Descriptive Information

5.6.3.1. Sealing Machine

A single-head sealer has been designed and built, employing the sealing method described in Paragraph 5.6.2 2. and Figures 17 and 18. The construction of the sealer is shown in Figures 19, 20, 21, and 22.

A stationary chuck aligns the glass bulb and base in the correct position relative to height and concentricity.

A small rotation of the compression cap enables the work to be clamped or

released.

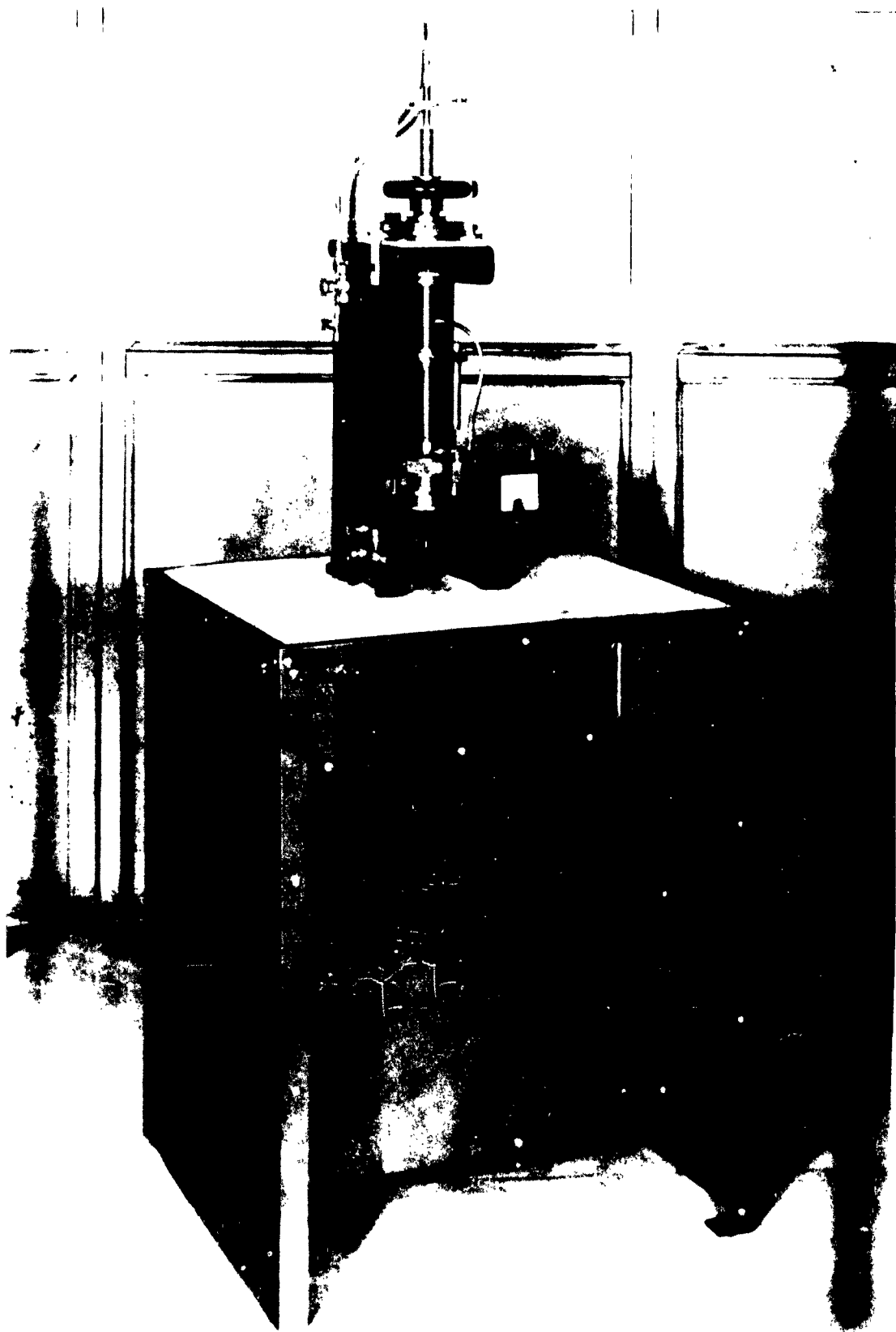

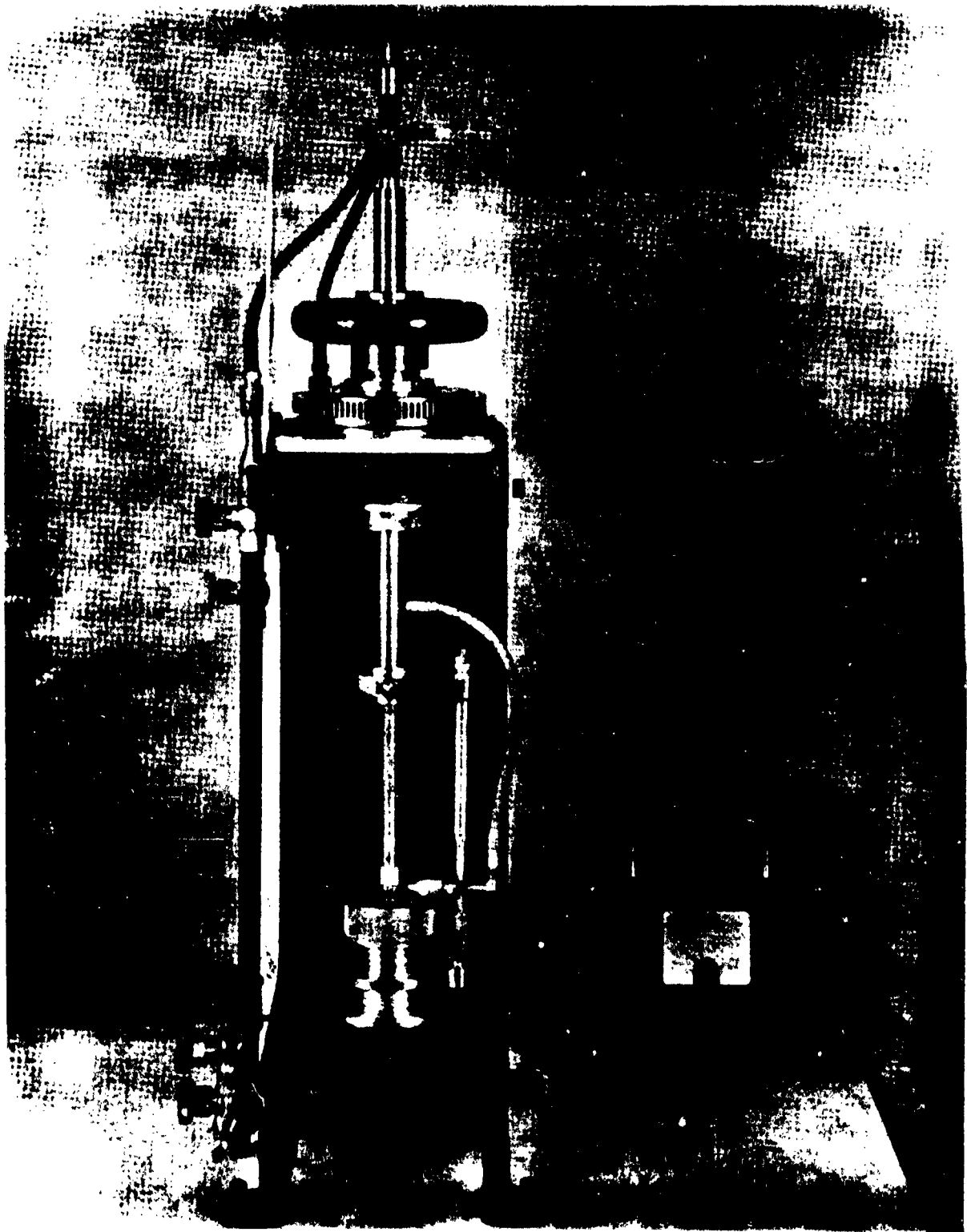

FIG. 18

5. GLASS WORKING AND SEALING (Continued)

5.6. (Continued)

5.6.3. Sealing Machine Descriptive Information (Continued)

5.6.3.1. Sealing Machine (Continued)

Around the main body of the chuck is mounted a cam with a profile duplicating the outside shape of the glass bulb.

A rotating tube, in line with the axis of the chuck, supports a pivoted arm. A gas oxygen burner is mounted on the pivoted arm in such a way that it can be adjusted initially. As the tube rotates, the distance from the burner to the work is controlled by a cam follower, located at the bottom of the arm. This follower rides on the cam profile mounted on the chuck. The height of the flame is adjusted by means of the hand operated collet on the rotating tube. A fixed tube mounted inside the rotating tube holds a retaining cup for supporting the bulb during sealing. The inside of the cup is lined with asbestos which fits tightly on the bulb to minimize the heat transfer to the crystal. Air can be supplied to the cup to cool the bulb.

5. GLASS WORKING AND SEALING (Continued)

5.6. (Continued)

5.6.3. Sealing Machine Descriptive Information (Continued)

5.6.3.1. Sealing Machine (Continued)

The premixed gas and oxygen is fed into the fixed tube through an opening into the rotating tube and through a flexible hose to the burner.

The upper head is driven through a gear train from a vertical shaft which is coupled to a gear reducer motor combination. The rate of rotation of the flame is approximately four revolutions per minute.

An auxiliary hand flame is used to preheat the seal area before sealing and to anneal the seal after sealing.

The electrical circuit diagram for the sealing machine is shown in Figure 23.

5.6.3.2. Vacuum System

Satisfactory evacuation is achieved by means of a Welch Duo Seal two-stage high vacuum pump (Model No. 1405). An electrically controlled valve is included in the vacuum line in order to isolate

5. GLASS WORKING AND SEALING (Continued)

5.6. (Continued)

5.6.3. Sealing Machine Descriptive Information (Continued)

5.6.3.2. Vacuum System (Continued)

the pump during loading. A Pirani vacuum gauge is connected to the vacuum line, in order to measure the vacuum.

5.6.3.3. Installation

The required services for the sealer are:

- a. Electrical supply 110 volt
60 cycle 20 amperes
- b. Gas
- c. Oxygen
- d. Low pressure air

5.6.3.4. Setting-Up Instructions

- a. Connect services to sealer.
- b. Load base and bulb, and check that the alignment is satisfactory.
- c. Lower stationary tube holding retaining cup and check alignment.
- d. Turn on vacuum pump and check that vacuum comes down to less than 100 microns Hg.

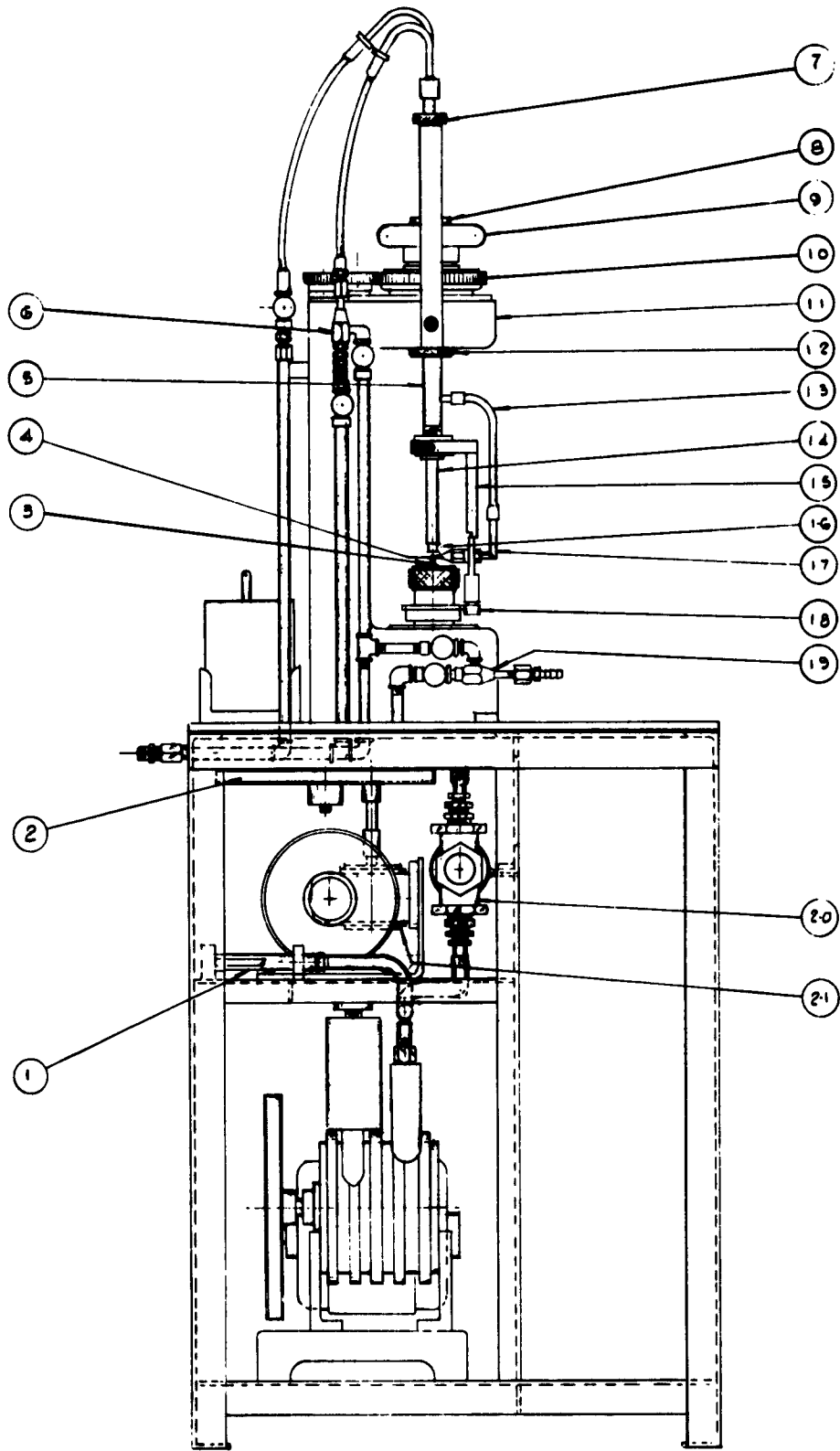

FIG. 20

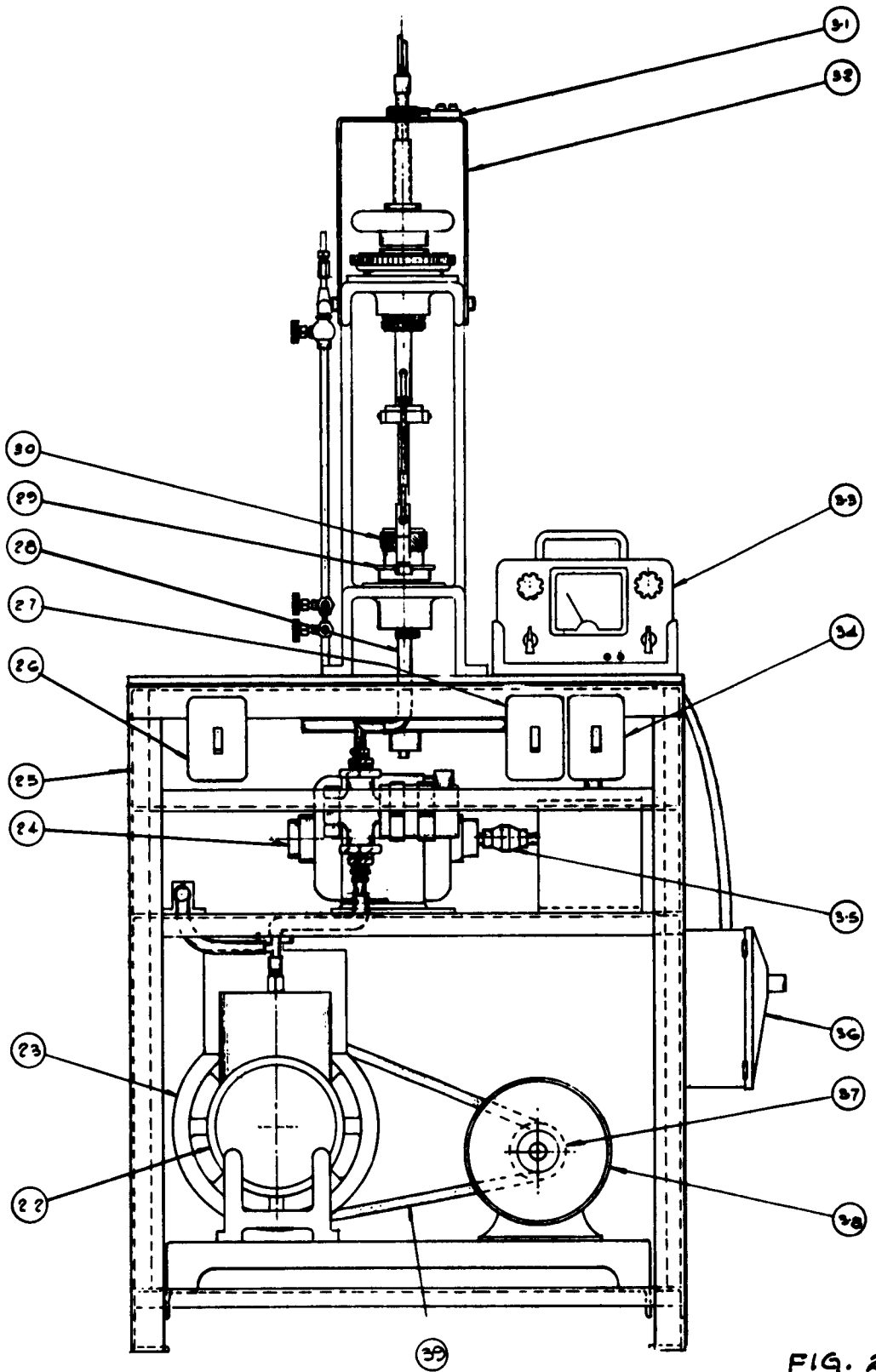
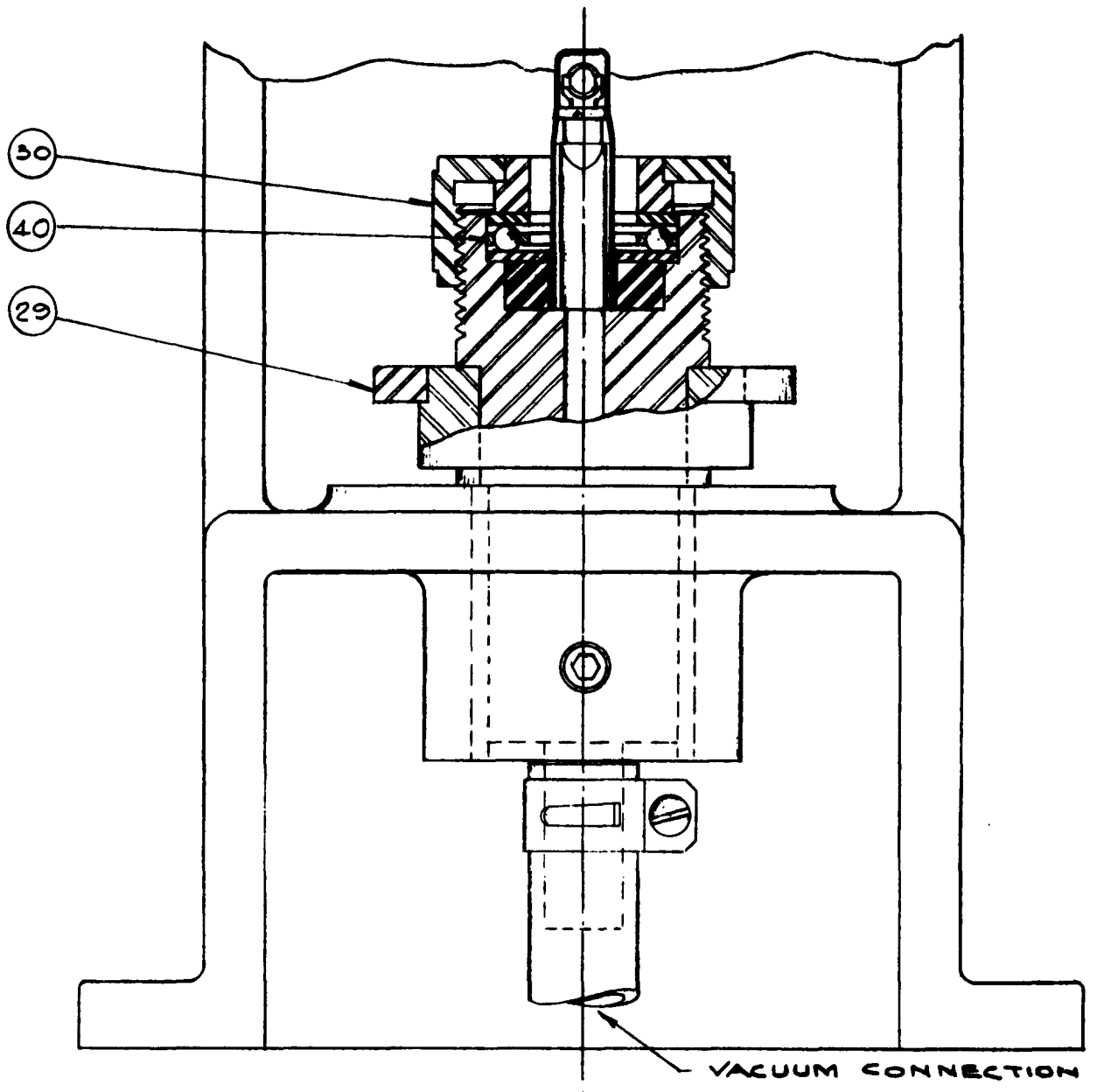

FIG. 21



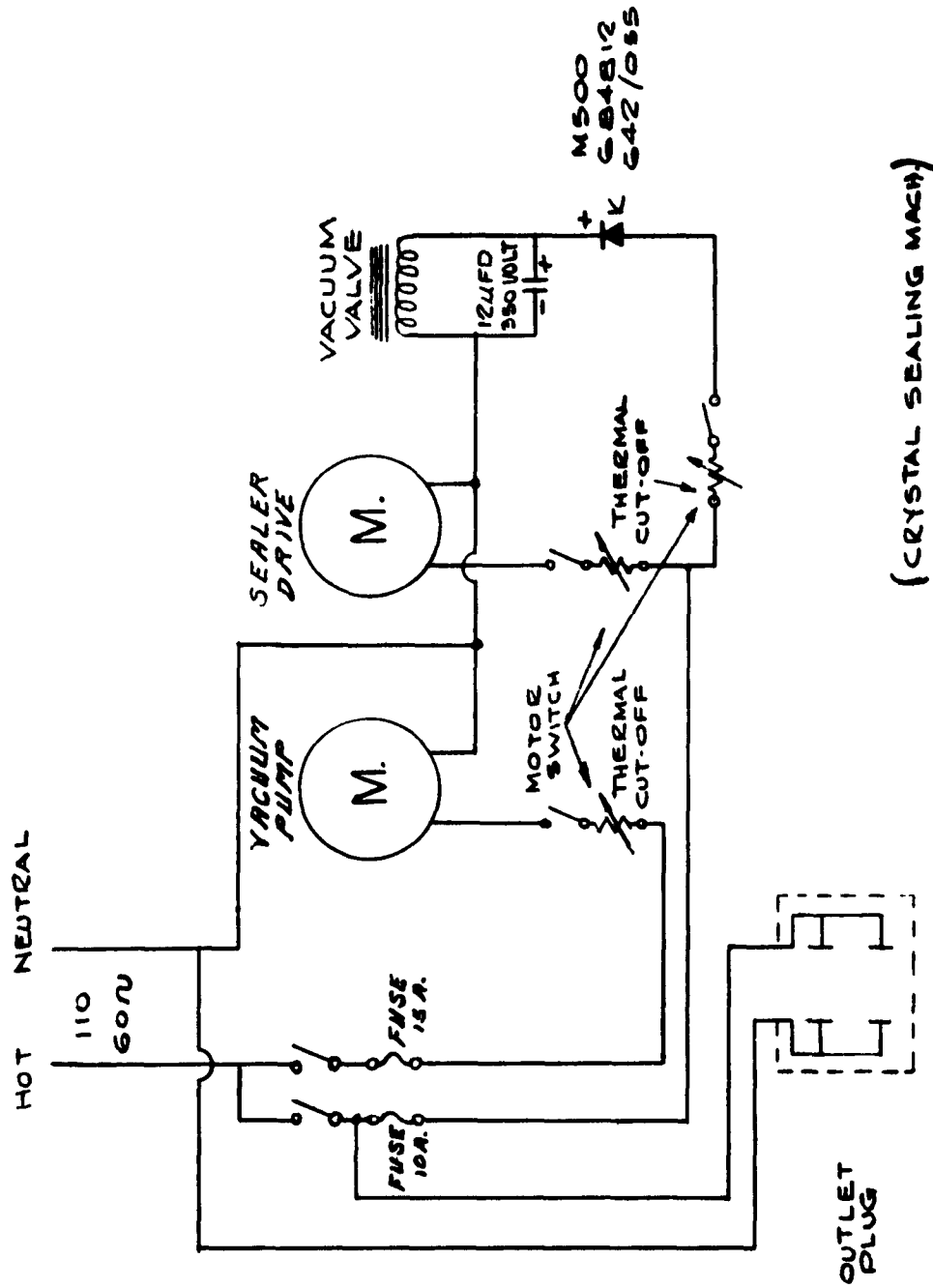

FIG. 23

5. GLASS WORKING AND SEALING (Continued)

5.6. (Continued)

5.6.3. Sealing Machine Descriptive Information (Continued)

5.6.3.4. Setting-Up Instructions (Continued)

- e. Light flame in rest position and swing burner to sealing position for base. Check that burner is directed to center point of support of burner. Adjust stop if necessary to bring height to center of base. Check that the distance from the burner to the bulb is satisfactory (approximately .150 inches).
- f. Start sealer motor. Adjust if necessary the flame to obtain a uniform seal. Seal should be complete in approximately one minute.

5.6.3.5. Operating Instructions

- a. Start vacuum pump with valve closed.
- b. Light flame in rest position, and turn on air for cooling.
- c. Load base on base support.
- d. Place bulb over base, insert as far as possible and clamp chuck by rotating compression cap.

5. GLASS WORKING AND SEALING (Continued)

5.6. (Continued)

5.6.3. Sealing Machine Descriptive Information (Continued)

5.6.3.5. Operating Instructions (Continued)

- e. Lower stationary tube to bring retaining cup over bulb.
- f. Open valve to vacuum system and evacuate to pressure of 100 microns Hg.
- g. Preheat the seal area with soft gas-air flame.
- h. Swing the flame to the sealing position and start sealer motor.
- i. After the seal has been completed, swing the sealing flame to rest position, and close vacuum valve. Open chuck by rotating compression cap.
- j. Anneal the seal area with a soft gas-air flame.
- k. Remove the sealed unit from the chuck.
- l. Cut sealed unit to correct length.

5. GLASS WORKING AND SEALING (Continued)

5.6. (Continued)

5.6.4. Sealing Process Faults And Their Correction

The faults which occur in HC-(XM-4)/U crystal units which are related to the sealing process are usually the result of one of the following causes:

- a. Not sufficient heat used during sealing.
- b. Excessive heat at crystal element.
- c. Loading of the quartz.

Fault a., insufficient heat, results in poor vacuum, leaky seals, and glass cracks. It is corrected by increasing the flame heat and/or reducing the rate of rotation.

Fault b., excessive heat at the crystal element, results in an increase in frequency, an increase in resistance, and in the extreme case, failure to oscillate. This can be corrected by reducing the flame heat and/or increasing the rate of rotation. This fault also occurs if the quartz blank is mounted too close to the seal area.

Fault c., loading of the quartz element, results in a decrease in frequency which is caused by a transfer of contamination to the quartz element. This can be corrected by improved cleaning of the holder parts or the sealing machine.

6. REVIEW BY HOLDER TYPE

6.1. HC-(XM-2)/U Holder

The initial design of this holder followed very closely that of the Philips RG-I holder. The only difference between the two designs is that the dimensional tolerances stipulated for the Corning holder are closer. So that the maximum amount of space is available within the bulb, the Corning nominal dimensions were slightly larger than those set by Philips. The initial designs for bulb and base major and minor diameters (the A, F, G, and J dimensions described in Section 4.2.) provided satisfactory results throughout the history of this project. The only changes required were those of bulb length and base thickness. The proper values for these dimensions were found by sealing experimentation.

Arrangements were made with L. L. Constantin And Company (succeeded by Isotronics, Inc.) of Lodi, New Jersey, to supply bases for the holders to Corning's specifications. Preliminary bulb and base samples were fabricated for sealing experimentation. Two special sealing beads were constructed to handle both the HC-(XM-2)/U and HC-(XM-3)/U holders. These sealing beads were for use on the Government owned sealing equipment located at Scientific Radio Products, Inc., Loveland, Colorado.

6. REVIEW BY HOLDER TYPE (Continued)

6.1. HC-(XM-2)/U Holder (Continued)

Section 4.1.6. of this report outlines the stipulation that the quartz blanks shall not exceed 250° C. during sealing. Initially it was intended to seal these holders without quartz blanks. Preliminary temperature indications were made using known melting point solders: 230° C., 250° C., and 285° C.

The expectations of this initial sealing work was to establish the final length dimension for the bulb and the optimum base thickness. The results were that good seals were achieved only when the 250° C. temperature was exceeded. Solders were attached to the middle of plated quartz blanks as well as to the spring mounting clips. These spring mounting clips cannot be made of the conventional spring steel wire, but must be fabricated from a suitable stainless steel alloy -- such as Number 302. It is not the purpose of this project to perfect quartz mounting clips, so stainless steel wire was formed in the same manner as spring steel wire clips, and welded in place on the Kovar leads instead of soldered.

Based on the aforementioned sealing experience, contractual changes were made so that pre-production samples were submitted based not on meeting a 250° C. maximum quartz temperature limit, but on demonstrating

6. REVIEW BY HOLDER TYPE (Continued)

6.1. HC-(XM-2)/U Holder (Continued)

that good quartz crystals could be successfully sealed in the holders. In actuality, this modification is completely compatible with the intentions and desires of the Government and the crystal manufacturers.

A second sealing test with quartz blanks was conducted. This test was to determine the amount of "squeeze" of bulb and base encountered during the optimum sealing cycle. "Squeeze" is the difference in overall assembled base and bulb height before and after sealing. When a good seal with proper seal geometry has been made, the squeeze is .045".

Although supposedly good seals were made with quartz crystals, the environmental test phase of the pre-production sample lot was not successful. Poor seal geometry caused failures on thermal shock testing. As noted before, -55° C. to boiling water is a shock more severe than had previously been specified. Slight re-entrant angles in the seal area can be the source of seal failure when thermally shocked. These re-entrancies are avoided and minimized by devoting careful attention to alignment of bulb and base in the sealing fixture.

A third pre-production test was conducted with quartz crystals sealed. These units, sealed at Philips

6. REVIEW BY HOLDER TYPE (Continued)

6.1. HQ-(XM-2)/U Holder (Continued)

Electronics Industries, Limited, met the environmental test requirements. Nineteen holders with quartz crystals of the following frequencies, 2.85, 40 and 70 Mc, were sealed as part of this pre-production test. Frequency and resistance before and after sealing are tabulated. No particular attempts were made to produce an exact frequency. The use of the quartz crystals demonstrated that good units can be sealed in glass holders.

Nominal Frequency	Frequency (cps from nominal)		Frequency Change (ppm)	Resistance (ohms)	
	Before Seal	After Seal		Before Seal	After Seal
2.85 Mc	+ 3	- 10	- 4.6	40	33
"	+ 26	0	- 9.1	100	100
"	+ 2	- 13	- 5.3	50	42
"	+ 16	+ 2	- 4.9	45	36
"	- 3	- 3	0	70	73
"	+ 20	+ 1	- 6.7	88	23
"	+ 15	- 2	- 6.0	50	39
40 Mc	- 20	- 312	- 0.2	27	17
"	+ 250	- 180	-10.7	27	18
"	+ 50	0	- 1.3	25	16
"	+2810	+2600	- 5.3	27	18
"	+ 160	+ 470	+ 7.8	27	18
"	0	+ 360	+ 9.0	27	20
70 Mc	+ 230	-2300	-36.1	49	38
"	+ 580	-1900	-35.5	48	48
"	+ 30	-1300	-19.0	63	56
"	- 190	-1970	-25.4	62	47
"	- 160	-2700	-35.3	48	40
"	- 580	-1830	-17.9	61	51

6. REVIEW BY HOLDER TYPE (Continued)

6.1. HC-(XM-2)/U Holder (Continued)

Pilot production of bulbs and bases was begun.

During this pilot run of bases, Corning Glass Works introduced a new material -- CLEARFORM^(R) ware. This material provides a means of producing 7052 precision shaped parts. These preformed parts were advantageously used to produce the clear glass bases. Since a new processing technique was introduced, plus a new base supplier, Tronex of Millville, New Jersey, another set of pre-production test samples was required. Samples were sealed and subjected to environmental tests and passed.

The pilot run was completed using the bulbs as approved in the third and fourth pre-production test. The bases used were made using the CLEARFORM^(R) glass parts.

6. REVIEW BY HOLDER TYPE (Continued)

6.2. HC-(XM-3)/U Holder

Although this holder was not one which had previously been developed, the initial design followed exactly that used for the HC-(XM-2)/U holder with the exception of the bulb length and the length of the Kovar leads. As previously mentioned, sealing heads were designed and constructed to accommodate both the HC-(XM-2)/U and HC-(XM-3)/U holders.

The work done on the HC-(XM-2)/U holder showed that a maximum quartz temperature limit of 250° C. was not readily attainable. Normally the type of quartz units mounted in the comparable metal holders (HC-13/U) are held in place with solders that melt at temperatures below 200° C.

Initial sealing trials using Corning bulbs and bases from L. L. Constantin were conducted at Scientific Radio Products, Inc. Like the HC-(XM-2)/U holder, the 250° C. limit was exceeded -- as measured with the known melting point solders.

Although all holders of this contract carried the 250° C. maximum quartz crystal temperature limit, only the HC-(XM-2)/U and HC-(XM-4)/U holders had been developed for actual quartz units. Since this is an Industrial

6. REVIEW BY HOLDER TYPE (Continued)

6.2. HC-(XM-3)/U Holder (Continued)

Preparedness Contract, development of a special quartz crystal mounting technique was beyond the original scope and intent. Nevertheless the approach was taken that possibly higher temperature solders and/or welding could be used for crystal mounting.

Previous sealing work with the HC-(XM-2)/U holder indicated that the temperature adjacent to the seal area at a point where the quartz units would be mounted would be at a temperature of 300° C. or more. Solders, metals, or alloys of the following melting points were used: 230° C., 250° C., 285° C., 327° C.

The bases of the HC-(XM-3)/U holders were prepared so that at various locations along the height of the two Kovar pins, transverse wires of .009" diameter nickel or .007" phosphor-bronze were welded in place.

Since the heat is supplied through an R-F induction coil, it is desirable to keep the amount of metal that cuts through the lines of magnetic flux to a minimum. Any metal members that are in this field should be discontinuous. As a result, these transverse wires were cut, after welding to the Kovar pins, to eliminate closed loop magnetic circuits.

6. REVIEW BY HOLDER TYPE (Continued)

6.2. HC-(XM-3)/U Holder (Continued)

The effect of a cooled split copper heat sink in contact with that portion of Kovar pin outside the enclosure was not successful. This extra amount of metal tended to heat the Kovar pins more, causing the temperature indicating solders to melt more readily.

The temperature of the Kovar pins is elevated in three ways:

1. Induction from the energized R-F coil.
2. Radiation from the heated Kovar sealing ring.
3. Conduction through the glass from the heated Kovar sealing ring to the Kovar pins, followed by conduction in the pin itself.

The temperature at which solders melted increased as the distance from the Kovar ring increased. This would tend to substantiate a combination of Factors 2 and 3 above.

The data taken tend to indicate that at the following heights above the plane of the Kovar ring, the following solders did not melt.

<u>Distance Above Kovar Ring</u>	<u>Solder</u>
3/8"	-327° C.
1/2"	-285° C.
5/8"	-250° C.

6. REVIEW BY HOLDER TYPE (Continued)

6.2. HC-(XM-3)/U Holder (Continued)

Arrangements were made with Reeves-Hoffman Division of Dynamics Corporation Of America, Carlisle, Pennsylvania, to attempt to mount CR-38/U crystals of the following frequencies: 24, 36, 51, and 100 Kc. The solders to be used were 280° C., 292° C., and 315° C. Although this manufacturer modified the standard procedures used to fabricate crystals of this type, the attempts to satisfactorily mount crystals were unsuccessful. The report of this work follows:

"SUBJECT: Reeves-Hoffman Division Project C-9413
for Corning Glass Works. Process 24, 36,
51 and 100 Kc. CR-38/U crystals using
high temperature solder, to be mounted on
special glass header and envelope supplied
by Corning Glass Works.

"ABSTRACT

"The attempt to fabricate a crystal for mounting in HC-(XM-3)/U holder for Corning Glass Works has not been successful. The solders requiring temperature of about 300° C. are required to withstand the heat necessary to seal the envelope lead attachment employing these solders achieve a bond of insufficient strength to withstand the forces encountered in fabricating the unit for mounting.

6. REVIEW BY HOLDER TYPE (Continued)

6.2. HO-(XM-3)/U Holder (Continued)

"ABSTRACT (Continued)

"The crystals were prepared by standard procedures summarized as follows:

Cut: NT

Surface Finish: 12.5 Micron Abrasive

Etch: NH_4 : FHF, 50° C., 105 sec.

Spot: At nodal point, Hanovia liquid silver
No. 150, .042 inch diameter, ca .0002
inch thick fired at 550° C.

Gold Plate: Sputtered 25 min.

125 ma. at 50 microns of Hg

"The following are the phases of crystal finishing accomplished.

"LEAD PREPARATION

"Gold plated, phosphor bronze (ASTM Alloy C) headed wires, .0063 inches in diameter were employed.

"The head of the wire was 'tinned' about .025 inches by immersing in molten solder of the alloy to be used for the lead attachment.

"Solder spheres, .018 inch diameter, were attached to the 'tinned' portion of the wire. The spheres were melted in molten stearine flux.

6. REVIEW BY HOLDER TYPE (Continued)

6.2. HC-(XM-3)/U Holder (Continued)

"LEAD PREPARATION (Continued)

"The stearine flux quickly boiled away and required constant replacement. The vapors were very annoying and on occasion became hot enough to ignite.

"The spheres melting at 280° C. were the most difficult to place on the wires. The least difficulty was encountered with those melting at 292° C.

"All leads required three rinses in trichlorethylene to remove oxidized flux.

"The chromed dish for pellet placement was cleaned by an overnight soak in Oakite Rustripper.

"The following temperatures were required of the hot plate to prepare the leads:

<u>Melting Point Of Solder</u>	<u>Temperature Used</u>
280° C.	320° C.
292° C.	330° C.
315° C.	355° C.

6. REVIEW BY HOLDER TYPE (Continued)

6.2. HC-(XM-3)/U Holder (Continued)

"LEAD PREPARATION (Continued)

"The following solders were supplied by Corning

Glass Works:

<u>Alloy</u> <u>No.</u>	<u>Indium</u> <u>%</u>	<u>Lead</u> <u>%</u>	<u>Silver</u> <u>%</u>	<u>Melting</u> <u>Point</u>
83	5	92.5	2.5	280 - 285° C.
87	5	95	-	315° C.
88	5	90	5	292° C.

"LEAD ATTACHING

"The thermostat of the platen of the lead attach machine was disconnected and the temperature controlled by adjusting the variac.

"The following temperatures were measured:

Platen: ca 500° F. (260° C.)

Air Blast: ca 740° F. (393° C.)

"The rosin-alcohol flux normally used did not cause the solder to flow.

"A flux of the zinc chloride in water type (Nalco 14) was necessary. The high temperature caused the water to boil with much vigor leaving a residue of zinc chloride which readily charred. The burned residue contaminated the work surface making the operation extremely difficult.

6. REVIEW BY HOLDER TYPE (Continued)

6.2. HC-(XM-3)/U Holder (Continued)

"LEAD ATTACHING (Continued)

"A lead was attached, the crystal washed in distilled water, dried, and returned to the platen for the opposite lead.

"A final cleaning in boiling distilled water was used to remove all traces of flux.

"The appearance of the solder cone did not conform to R-H standards.

"The holding jaws of the lead attach machine were removed and the entire working surface cleaned with cleaner and steel wool.

"PRIMARY FREQUENCY ADJUSTMENT

"The crystals were suspended between spring loaded jaws connected to an oscillator. The lead attachment of 10% of the units failed to withstand this handling.

"BENDING THE LEADS FOR MOUNTING

"The lead attachment of all remaining crystals failed to withstand the handling necessary to bend the wire preparatory to mounting.

6. REVIEW BY HOLDER TYPE (Continued)

6.2. HC-(XM-3)/U Holder (Continued)

"BENDING THE LEADS FOR MOUNTING (Continued)

"The tensile strength of the lead attachment was considerably less than is obtained with eutectic solders and rosin flux.

"WEIGHT ATTACHMENT

"Attempts were made to place dampening weights on the wires. (Weight 38 mg., M.P. 292° C.)

"The soldering tool was heated in excess of 320° C. The pellets placed in stearine palmoil flux.

"The usual procedure of rolling a molten pellet down the soldering iron was tried.

"A zinc chloride flux (Kester 714) was first applied to the wire.

"The iron did not impart sufficient energy to the solder for it to properly adhere on the wire.

"ADAPTING MICA SPACER TO ENVELOPE

"Mica spacers (Reeves-Hoffman Part C-1067) with two nickel eyelets were resized to fit the glass envelope.

6. REVIEW BY HOLDER TYPE (Continued)

6.2. HC-(XM-3)/U Holder (Continued)

"ADAPTING MICA SPACER TO ENVELOPE

"A No. 600 abrasive paper was used to remove the excess mica. Abrading continued until the mica was reduced to size sufficient to fit the glass.

"The mica is intended to restrict the heat of sealing, thereby protecting the crystal."

Since conventional mounting techniques of quartz units for this holder type were not compatible with the temperature attained during sealing, contract modifications were made. These changes stipulated that pre-production test samples were to be sealed in the same manner as were HC-(XM-2)/U holders but without any quartz blanks, and subjected to the specified environmental tests.

Bulbs of 7052 glass and bases made of 7052 CLEARFORM^(R) parts were subject to pre-production testing. Environmental tests were passed and the pilot production was completed.

6. REVIEW BY HOLDER TYPE (Continued)

6.3. HC-(XM-4)/U Holder

The initial design of this holder followed very closely that of the Philips RG-2 holder. The Government owned sealing equipment located at McCoy Electronics, Mount Holly Springs, Pennsylvania, was used for initial sealing experimentation. The first sealing attempt was not successful but it demonstrated the need for a good fit between the bulb and the base as well as the need for uniformity of bulb wall thickness in the sealing area. This initial sealing work, even though not successful, indicated that quartz crystal temperatures would be near or greater than the 250° C. maximum stipulated.

After several changes in bulb and base design specifications, units were capable of being successfully sealed. When successful seals were made, the 250° C. limit as measured with solders was exceeded.

Accordingly, pre-production samples were made incorporating quartz crystals of frequencies 10 and 75 Mc. Frequency and resistance values before and after sealing are tabulated. No particular attempts were made to produce an exact frequency. The use of quartz crystals demonstrated that good units can be sealed in glass holders.

6. REVIEW BY HOLDER TYPE (Continued)

6.3. HC-(XM-4)/U Holder (Continued)

Nominal Frequency	Frequency (cps from nominal)		Frequency Change (ppm)	Resistance (ohms)	
	Before Seal	After Seal		Before Seal	After Seal
75 Mc	-580	+ 370	+12.7	39	32
"	-410	+1246	+22.1	55	1246
"	-432	- 893	- 6.1	38	33
"	+740	+1618	+11.7	33	27
"	-475	+ 818	+17.3	35	27
"	-582	+ 50	+ 8.4	48	39
"	-777	+ 551	+17.7	36	28
"	-826	+ 106	+12.4	33	27
"	-445	+ 222	+ 8.9	33	26
"	-105	+ 807	+12.2	36	32
"	-515	+ 488	+13.4	36	31
"	-417	+ 991	+18.8	34	26
10 Mc	+ 96	- 220	-31.6	22	12
"	+105	- 290	-39.5	21	10
"	+197	- 47	-24.4	21	12
"	+ 84	+ 7	- 7.7	24	14
"	+212	+ 34	-17.8	23	14
"	- 33	+ 4	+ 3.7	24	13
"	+ 34	- 205	-23.9	22	14
"	+ 47	- 59	-10.6	33	10
"	+206	- 240	-44.6	25	12
"	+ 54	- 205	-25.9	29	14
"	- 64	- 130	- 6.6	31	16
"	+108	Inactive	-	30	-

These sealed units were subjected to the environmental testing phase. Units were accepted. Pilot production was completed.

7. CONCLUSIONS AND RECOMMENDATIONS

7.1. HC-(XM-2)/U Holder

Although the desired 250° C. maximum quartz temperature was exceeded, it was demonstrated that good quartz crystals with frequencies as low as 2.85 Mc can be satisfactorily sealed in this glass holder of the design and materials specified by the Government in Section 4. above. The length of the bulb used for the pre-production tests yielded sealed holders on the short side of the finished specification. It is suggested that subsequent bulbs be made longer to provide greater space within the holder and still be compatible with the finished holder specification. The Corning bulb specification accompanying this report shows this suggested length dimension of .705".

Base forming experience by Tronex, since the completion of the pre-production tests and pilot run, suggest that less expensive base production will be achieved through two modifications:

- a. Remove the recess or counterbore around the Kovar pin at the outside surface of the base.
- b. Eliminate the need for glazing the Kovar sealing ring.

Neither of these two suggestions was tried or proven under the work of this contract.

7. CONCLUSIONS AND RECOMMENDATIONS (Continued)

7.2. HC-(XM-3)/U Holder

To this writer's knowledge, there is no crystal unit that is currently enclosed in a HC-13/U holder that can be encapsulated in this glass holder. Accordingly, crystals and crystal mounting techniques must be developed if units meeting the pertinent requirements of Section 4, above are to be met.

The possibility exists that lower sealing temperatures might be achieved using materials other than those specified in the original requirements of this contract. The use of alternate or additional materials would tend to complicate an already compromised sealing technique. However, in any hermetic sealing system, it is usually desirable and advantageous to keep the system as simple as possible; that is, avoid introducing dissimilar materials that have differing thermal coefficients of expansion or different viscosity characteristics.

Since the sealing method for the HC-(XM-3)/U and HC-(XM-2)/U holders are the same, any reduction of sealing temperature for one would be applicable for the other.

Base forming experience by Tronex, since the completion of the pre-production tests and pilot run, suggest that

7. CONCLUSIONS AND RECOMMENDATIONS (Continued)

7.2. HC-(X4-3)/U Holder (Continued)

less expensive base production will be achieved through two modifications:

- a. Remove the recess or counterbore around the Kovar pin at the outside surface of the base.
- b. Eliminate the need for glazing the Kovar sealing ring.

Neither of these two suggestions has been tried or proven under the work of this contract.

7. CONCLUSIONS AND RECOMMENDATIONS (Continued)

7.3. HC-(XM-4)/U Holder

The desired temperature of 250° C. was exceeded, but it was satisfactorily demonstrated that good quartz crystals with frequencies as low as 10 Mc can be sealed in this glass holder.

Bulb forming experience, since the completion of the pre-production tests and pilot run, suggest that less expensive bulb production will be achieved if the overall length of the bulb is changed from 2.031" to 1.500", or shorter. Such a change may require that sealing equipment be modified.

8. REFERENCES

- 8.1. Dalton, R. H., "Glass-To-Metal Seals", from
First Symposium On The Art Of Glassblowing (1956),
Wilmington 3, Delaware: The American Scientific
Glassblowers Society
- 8.2. Hagy, H. E., Thermal Expansion Differential Tables,
Corning, New York: Corning Glass Works, 1962
- 8.3. Shand, E. B., Glass Engineering Handbook, New York:
McGraw-Hill Book Company, 1958
- 8.4. Properties Of Selected Commercial Glasses, Form B-83,
Corning, New York: Corning Glass Works, 1961
- 8.5. RG-1, Glass Evacuated Crystal Holder - Sealing
Information And Equipment, Canadian Radio Manufacturing
Corporation, Limited, Toronto, Ontario, CANADA, (Now
known as Philips Electronics Industries, Limited)
- 8.6. RG-2, Glass Evacuated Crystal Holder - Sealing
Information And Equipment, Canadian Radio Manufacturing
Corporation, Limited, Toronto, Ontario, CANADA, (Now
known as Philips Electronics Industries, Limited)

9. ACKNOWLEDGMENTS

CORNING GLASS WORKS and the author wish to acknowledge the help and assistance rendered by the personnel of several companies and Government agencies:

Isotronics, Inc., and L. L. Constantin And Company,
Lodi, New Jersey

McCoy Electronics Company, Mount Holly Springs,
Pennsylvania

Philips Electronics Industries, Limited, Toronto,
Ontario, CANADA

Reeves-Hoffman Division Of Dynamics Corporation Of
America, Carlisle, Pennsylvania

Scientific Radio Products, Inc., Loveland, Colorado
Tronex, Inc., Millville, New Jersey

(United States Army Signal Supply Agency) now called:
United States Army Electronic Materiel Agency,
Philadelphia, Pennsylvania

(United States Army Signal Equipment Support Agency)
now called: United States Army Signal Materiel
Support Agency, Fort Monmouth, New Jersey

A P P E N D I X

On the following pages are detail drawings of the Corning modifications of the sealing head. These modifications allow both the HC-(XM-2)/U and HC-(XM-3)/U holders to be sealed on the same machine.

#5/16 TAPER PIN FIT ASS'Y. WITH
 PART #SK-1-59-D-9 & 10

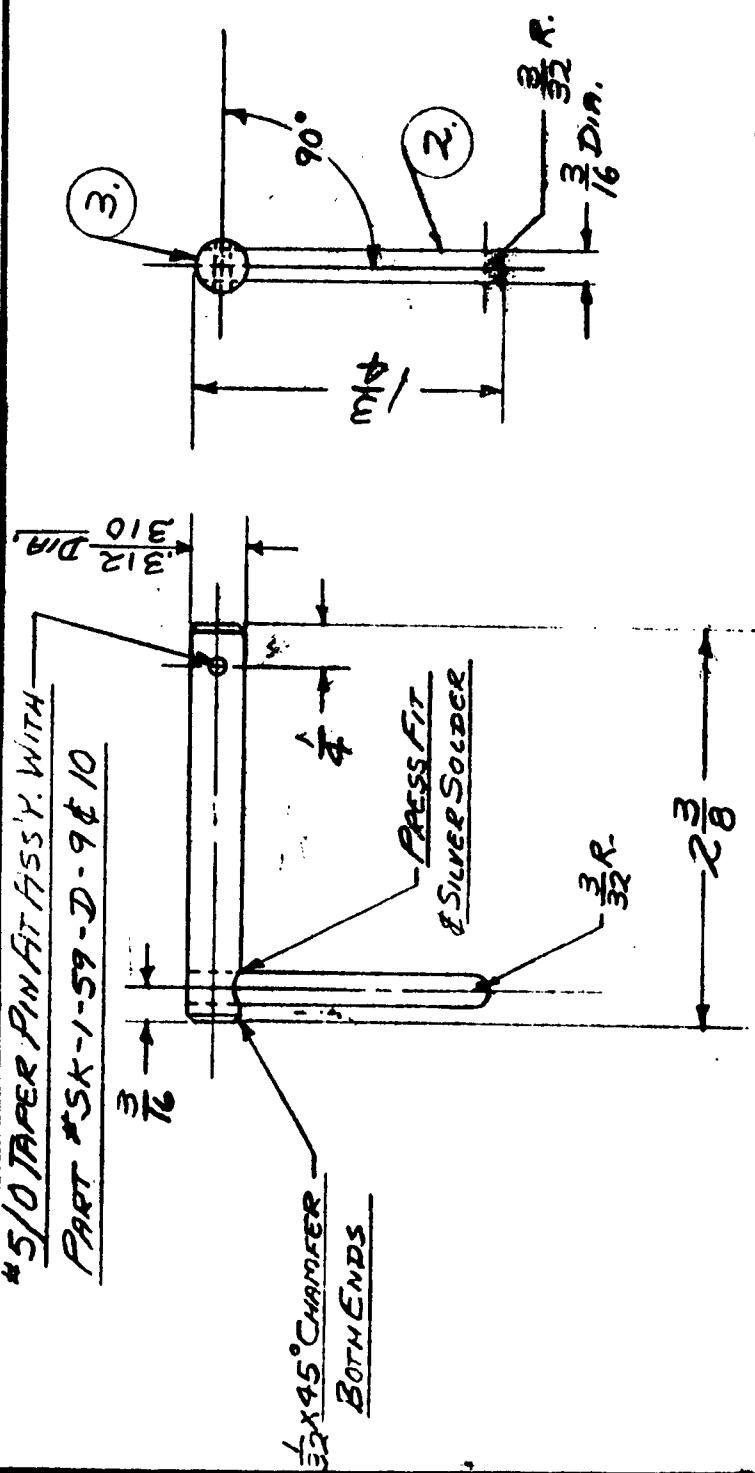

1/2 X 45° CHAMFER
 BOTH ENDS

DATE	NO.	REVISED	APPL.	DET.	CHK.

TOLERANCES UNLESS OTHERWISE SPECIFIED	16	MATERIAL	CRS	SHAFT - SEALING HEAD ASSEMBLY
DECIMAL DIMENSIONS ± .005	32	S. A. E. SPEC.		ADAPTED TO SEAL CRYSTAL HOLDERS:
FRACTIONAL DIMENSIONS 0 - 18" ± 1/64	63	HEAT TREAT		HC-(XM-2)U & HC-(XM-3)U
18" - 36" ± 1/32	125	PATTERN NO.		DRY. ELEC. PRODUCTS DEPT. FALL BROOK
36" AND OVER ± 1/16	250	NO. MOD'.	ONE	CORNING GLASS WORKS
ANGULAR DIMENSIONS ± .30 MINUTES		FINISH		PF. HILL
ANGLES GIVEN IN DEGREES ± .5 MINUTES		ASSEMBLY NO.	SK-1-59-D-28	FORM FULL
ANGLES GIVEN IN DEGREES ± .5 MINUTES				DATE 1-8-59

SK-1-59-D-28

FORM FULL

DATE 1-8-59

SK-1-59-D-28

FORM FULL

DATE 1-8-59

SK-1-59-D-28

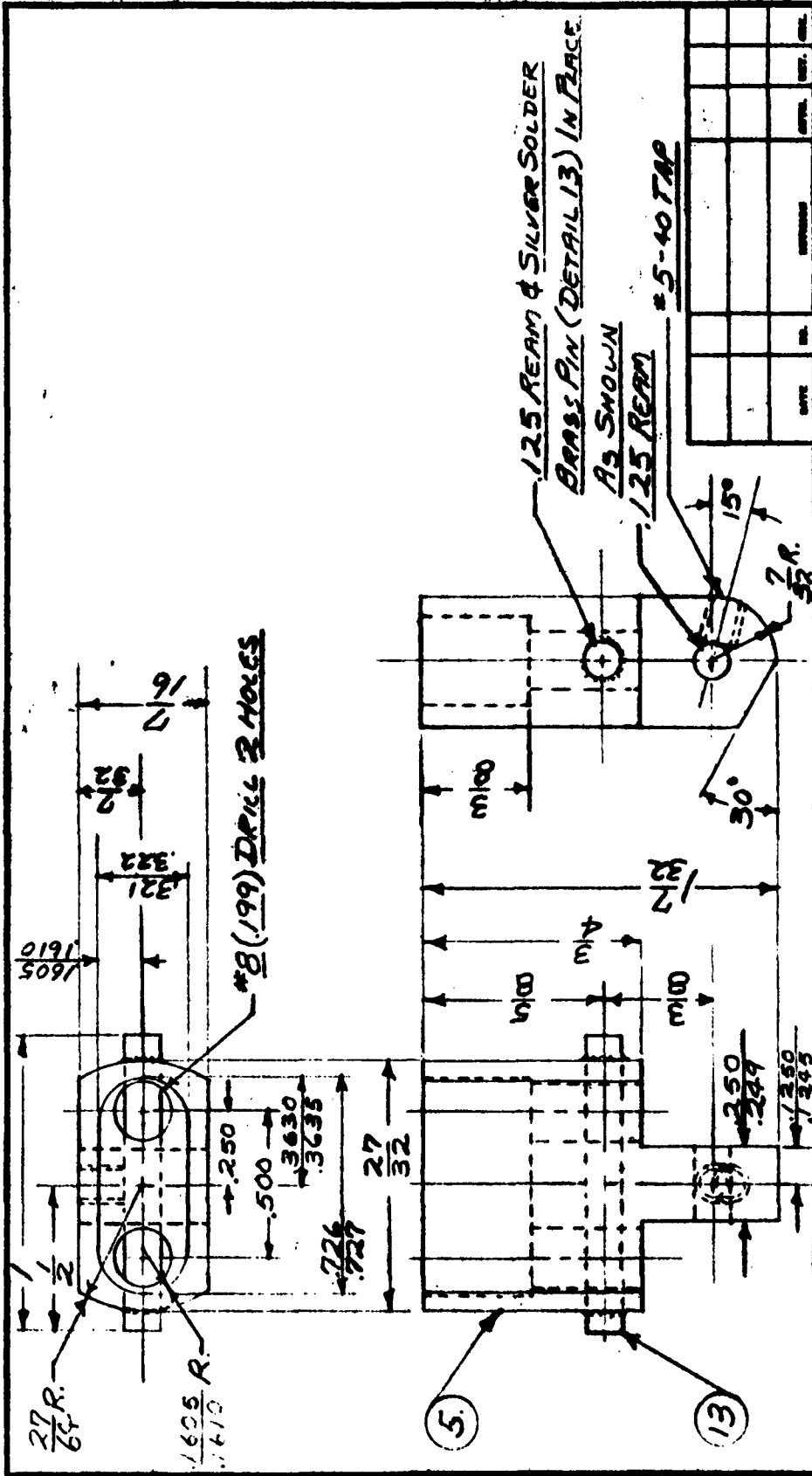

TOLERANCES UNLESS OTHERWISE SPECIFIED		FINISH	NO. REQ'D.	PATTERN NO.	HEAT TREAT	MATERIAL	BULO HOLDER - SEALING HEAD ASSEMBLY	
DECIMAL DIMENSIONS ± .005		125	ONE	OR BRASS	OR BRASS	COPTER PREPARED	ADAPTED TO SEAL CRYSTAL HOLDERS :	
FRACTIONAL DIMENSIONS 0 - 12" ± 1/64 12" - 24" ± 1/32 24" AND OVER ± 1/16		250					HC-(XM-2)/U & HC-(XM-3)/U	
ANGULAR DIMENSIONS ANGLES GIVEN IN DEGREES ± 30 MINUTES							DIV. ELEC. PRODUCTS DEPT. FALL BROOK	
ANGLES GIVEN IN DEGREES MIN. ± 5 MINUTES							CORNING GLASS WORKS	
							SCALE	DATE
							2 X	1-6-58
							SK-1-59-D-5	

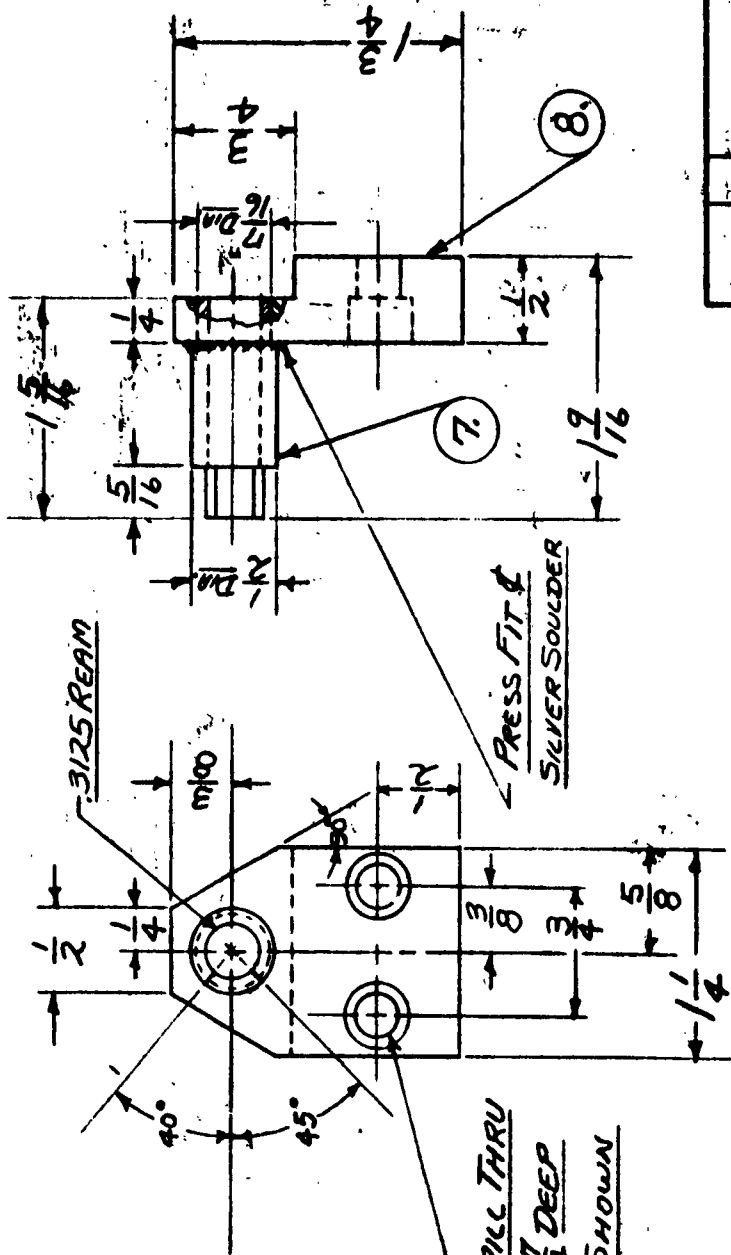

3/16 REAM

17/64 DRILL THRU
 25/64 C BORE 17/64 DEEP
 2 HOLES AS SHOWN

PRESS FIT &
 SILVER SOLDER

DATE	NO.	REV.	APP.	CHK.

TOLERANCES UNLESS OTHERWISE SPECIFIED		MATERIAL		CRS		SHAFT SUPPORT ~ SEALING HEAD ASSEMBLY	
DECIMAL DIMENSIONS ± .005		S. A. E. SPEC.		ONE		ADAPTED TO SEAL CRYSTAL HOLDERS:	
FRACTIONAL DIMENSIONS 0 15' ± 1/64		TREAT TREAT		PATTERN NO.		HC-(XM-2)/U & HC-(XM-3)/U	
15' - 24' ± 1/32		PATTERN NO.		NO. REQ'D.		DIV. ELEC PRODUCTS DEPT. FALL BROOK	
24' AND OVER ± 1/16		FINISH		FILE		CORNING GLASS WORKS	
ANGULAR DIMENSIONS ANGLES GIVEN IN DEGREES ± 30 MINUTES		FINISH		FILE		SCALE FULL	
ANGLES GIVEN IN MINUTES ± 5 MINUTES		FINISH		FILE		DATE 1-26-59	
		DRAWN		FILE		SK-1-59-D-7 & 8	
		CHECK		FILE			

#5/0 TAPER PIN AT ASS'Y.

BREAK SHARP EDGE

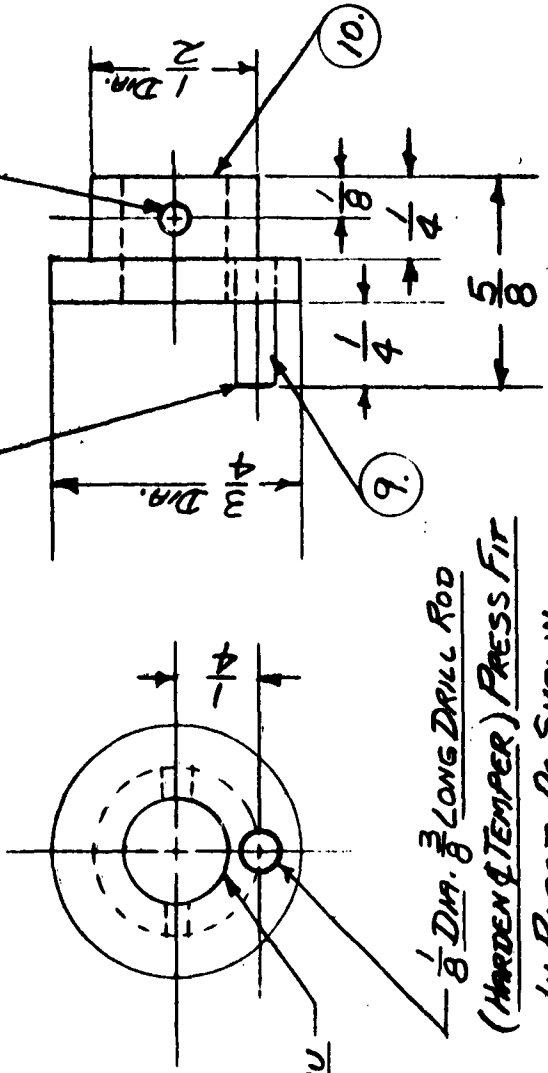

3/25 REAM THRU

1/8 DIA. LONG DRILL ROD

(HARDEN & TEMPER) PRESS FIT

IN PLACE AS SHOWN

DATE	NO.	ISSUES	APPR.	CHK.

TOLERANCES UNLESS OTHERWISE SPECIFIED	FINISH	Y	MATERIAL				
	GRIND	16	CARS				
DECIMAL DIMENSIONS ± .005	BLANK	32	S. A. E. SPEC.				
FRACTIONAL DIMENSIONS 0 - 12" ± 1/64	TYPE	63	HEAT TREAT				
12" - 24" ± 1/32	BLANK	125	PATTERN NO.				
24" AND OVER ± 1/16	MILL	250	NO. REVD. ONE				
ANGULAR DIMENSIONS ANGLES GIVEN IN DEGREES ± 30 MINUTES	TURN		FINISH				
ANGLES GIVEN IN DEGREES & MIN. ± 5 MINUTES	MILL		ASSEMBLY NO. SK-1-59-D-28				
	FILE		DRAWN BY PF HILL				
			CHECK DATE 1-26-59				
			SCALE 2X				
			DEPT. FALLBROOK				
			CORNING GLASS WORKS				
			LIFT WHEEL ~ SEALING HEAD ASSEMBLY				
			ADAPTED TO SEAL CRYSTAL HOLDERS				
			HC-(XM-2)/U & HC-(XM-3)/U				
			SK-1-59-D-9 & 10				

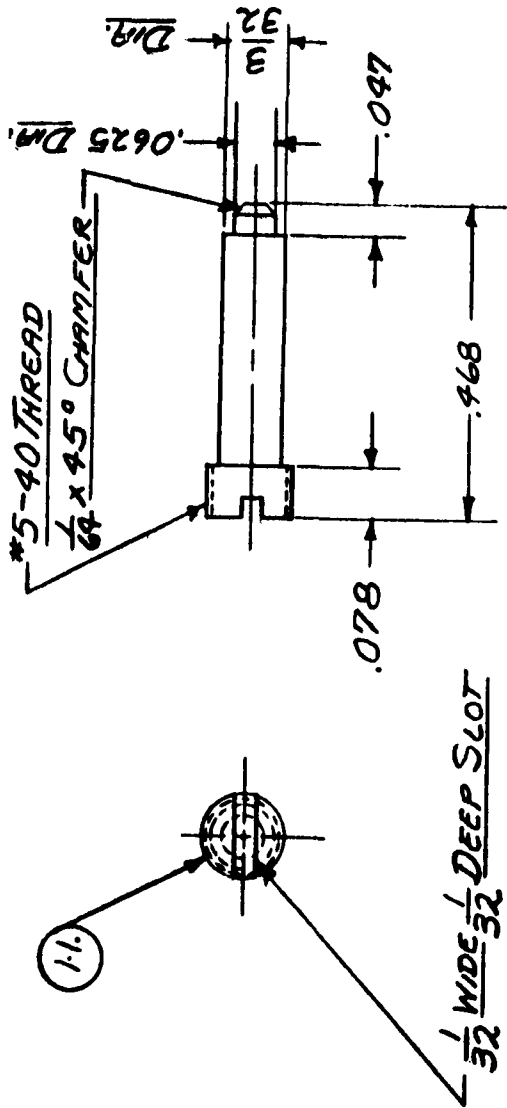

(1:1)
 1/32 WIDE 1/32 DEEP SLOT

DATE	BY	OFFICE	APPR.	CHK.

TOLERANCES UNLESS OTHERWISE SPECIFIED		FINISH SPEC.	MATERIAL	SPRING HOLDER ~ SEALING HEAD ASSEMBLY	
DECIMAL DIMENSIONS ± .005		Y	CRS	ADAPTED TO SEAL CRYSTAL HOLDERS:	
FRACTIONAL DIMENSIONS ± 1/64		16	S. A. E. SPEC.	HC-(XM-2)/U & HC-(XM-3)/U	
0 - 12" ± 1/32		32	HEAT TREAT	DIV. ELECT. PRODUCTS DEPT. FALLBROOK	
12" - 24" ± 1/16		63	PATTERN NO.	CORNING GLASS WORKS	
24" AND OVER ± 1/8		125	NO. REV'S.	SCALE 4X	
ANGULAR DIMENSIONS ANGLES GIVEN IN DEGREES ± .30 DEGREES		250	FINISH	DATE 1-26-59	
ARCS GIVEN IN DEGREES ± 5 MINUTES		500	ASSEMBLY NO.	SK-1-59-D-28	
		FILE			

SK-1-59-D-11

#53 (0.575) DRILL THRU & C'SINK
1/2 DEEP 2 HOLES

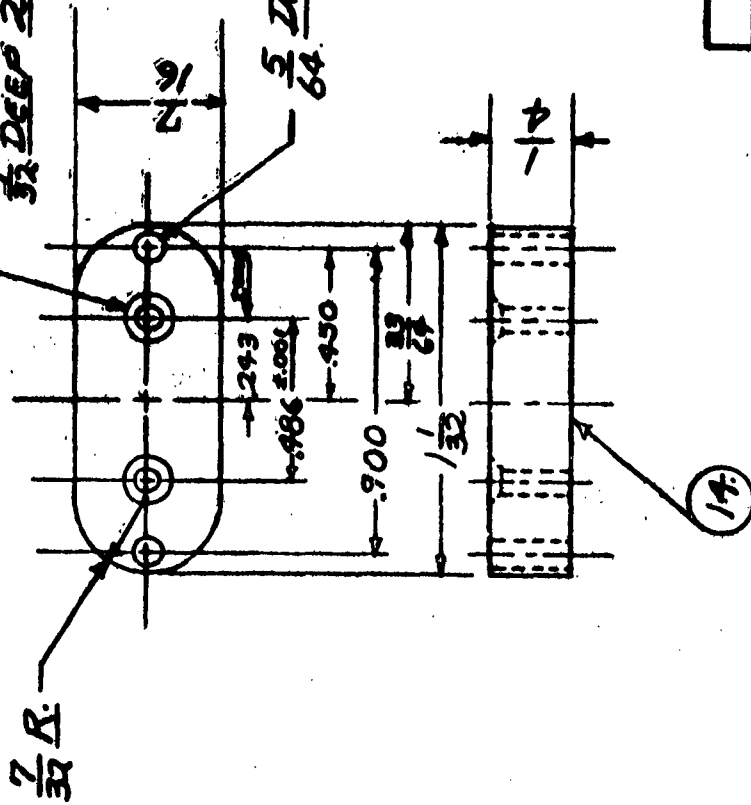

DATE	BY	DESIGN	APP. NO.

TOLERANCES UNLESS OTHERWISE SPECIFIED		FORM SPEC.	DATE	BY	DESIGN	APP. NO.
DECIMAL DIMENSIONS ± .005		10				
FRACTIONAL DIMENSIONS 0 - 12" ± 1/64		20				
12" - 24" ± 1/32		30				
24" AND OVER ± 1/16		40				
ANGULAR DIMENSIONS ANGLES GIVEN IN DEGREES ± .20 DEGREES		50				
ANGLES GIVEN IN DIMETERS ± .20 DIMETERS		60				
ANGLES GIVEN IN DEGREES & DIM. ± .5 DEGREES		70				
		80				
		90				
		100				
		110				
		120				
		130				
		140				
		150				
		160				
		170				
		180				
		190				
		200				
		210				
		220				
		230				
		240				
		250				
		260				
		270				
		280				
		290				
		300				
		310				
		320				
		330				
		340				
		350				
		360				
		370				
		380				
		390				
		400				
		410				
		420				
		430				
		440				
		450				
		460				
		470				
		480				
		490				
		500				
		510				
		520				
		530				
		540				
		550				
		560				
		570				
		580				
		590				
		600				
		610				
		620				
		630				
		640				
		650				
		660				
		670				
		680				
		690				
		700				
		710				
		720				
		730				
		740				
		750				
		760				
		770				
		780				
		790				
		800				
		810				
		820				
		830				
		840				
		850				
		860				
		870				
		880				
		890				
		900				
		910				
		920				
		930				
		940				
		950				
		960				
		970				
		980				
		990				
		1000				
		1010				
		1020				
		1030				
		1040				
		1050				
		1060				
		1070				
		1080				
		1090				
		1100				
		1110				
		1120				
		1130				
		1140				
		1150				
		1160				
		1170				
		1180				
		1190				
		1200				
		1210				
		1220				
		1230				
		1240				
		1250				
		1260				
		1270				
		1280				
		1290				
		1300				
		1310				
		1320				
		1330				
		1340				
		1350				
		1360				
		1370				
		1380				
		1390				
		1400				
		1410				
		1420				
		1430				
		1440				
		1450				
		1460				
		1470				
		1480				
		1490				
		1500				
		1510				
		1520				
		1530				
		1540				
		1550				
		1560				
		1570				
		1580				
		1590				
		1600				
		1610				
		1620				
		1630				
		1640				
		1650				
		1660				
		1670				
		1680				
		1690				
		1700				
		1710				
		1720				
		1730				
		1740				
		1750				
		1760				
		1770				
		1780				
		1790				
		1800				
		1810				
		1820				
		1830				
		1840				
		1850				
		1860				
		1870				
		1880				
		1890				
		1900				
		1910				
		1920				
		1930				
		1940				
		1950				
		1960				
		1970				
		1980				
		1990				
		2000				
		2010				
		2020				
		2030				
		2040				
		2050				
		2060				
		2070				
		2080				
		2090				
		2100				
		2110				
		2120				
		2130				
		2140				
		2150				
		2160				
		2170				
		2180				
		2190				
		2200				
		2210				
		2220				
		2230				
		2240				
		2250				
		2260				
		2270				
		2280				
		2290				
		2300				
		2310				
		2320				
		2330				
		2340				
		2350				
		2360				
		2370				
		2380				
		2390				
		2400				
		2410				
		2420				
		2430				
		2440				
		2450				
		2460				
		2470				
		2480				
		2490				
		2500				
		2510				
		2520				
		2530				
		2540				
		2550				
		2560				
		2570				
		2580				
		2590				
		2600				
		2610				
		2620				
		2630				
		2640				
		2650				
		2660				

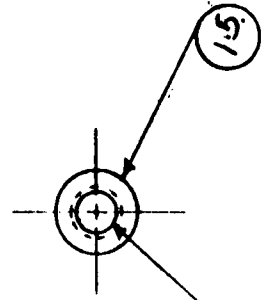
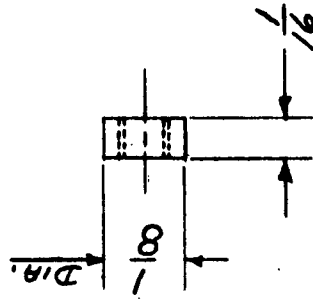

#1-64 TAP

DATE	NO.	ISSUES	APPR.	EXT.	CHK.

TOLERANCES UNLESS OTHERWISE SPECIFIED		FINISH SPEC.	MATERIAL	NUT ~ SEALING HEAD ASSEMBLY	
DECIMAL DIMENSIONS ± .008		Y	BRASS	ADAPTED TO SEAL CRYSTAL HOLDERS:	
FRACTIONAL DIMENSIONS 0 - 1/8" ± 1/64		1/8	S. A. E. SPEC.	HC-(XM-2)/U & HC-(XM-3)/U	
1/8" - 2 1/2" ± 1/32		32	HEAT TREAT	DIV. ELEC. PRODUCTS DEPT. FALL BROOK	
2 1/2" AND OVER ± 1/16		63	PATTERN NO.	CORNING GLASS WORKS	
ANGULAR DIMENSIONS ± 30 MINUTES		125	NO. MOD'S	MEMOR	
ANGLES GIVEN IN DEGREES & MIN. ± 5 MINUTES		250	FINISH	PF Hill	SCALE 4X
			ASSEMBLY NO.	SK-1-59-D-28	DATE 1-26-59
					SK-1-59-D-15

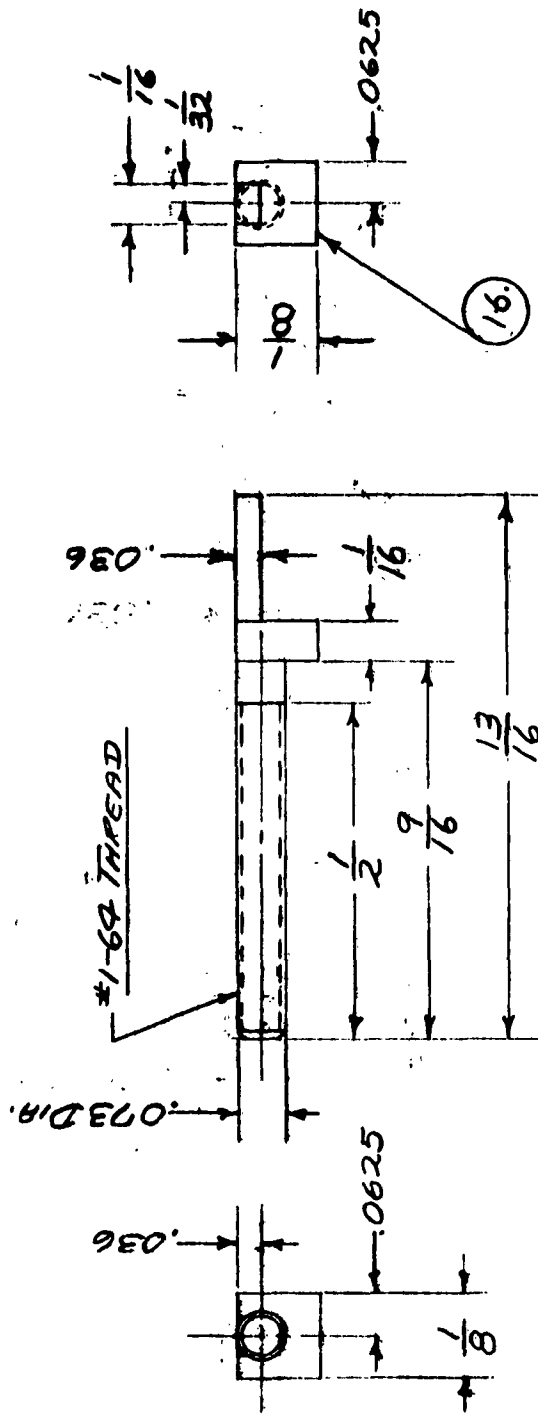

DATE	NO.	REVISION	APP'D.	BY

TOLERANCES UNLESS OTHERWISE SPECIFIED		FINISH SPEC.	MATERIAL	LOCATING PLATE HOLDER - SEALING HEAD ASSEMBLY
DECIMAL DIMENSIONS	± .005	✓	BRASS	ADAPTED TO SEAL CRYSTAL HOLDERS:
FRACTIONAL DIMENSIONS	± 1/64	16	S. A. E. SPEC.	HC-(XM-2)/U & HC-(XM-3)/U
9° - 12°	± 1/32	32	HEAT TREAT	DIV. ELEC. PRODUCTS DEPT. FALL BROOK
12° - 24°	± 1/32	63	PATTERN NO.	DESIGN
24° AND OVER	± 1/16	125	NO. REQ'D.	CORNING GLASS WORKS
ANGULAR DIMENSIONS	± 30 MINUTES	125	FINISH	DRAWN
ANGLES GIVEN IN DEGREES & MIN.	± 5 MINUTES	250	ASSEMBLY NO.	PF Hill
			SCALE	4 X
			DATE	1-27-59
				SK-1-59-D-16

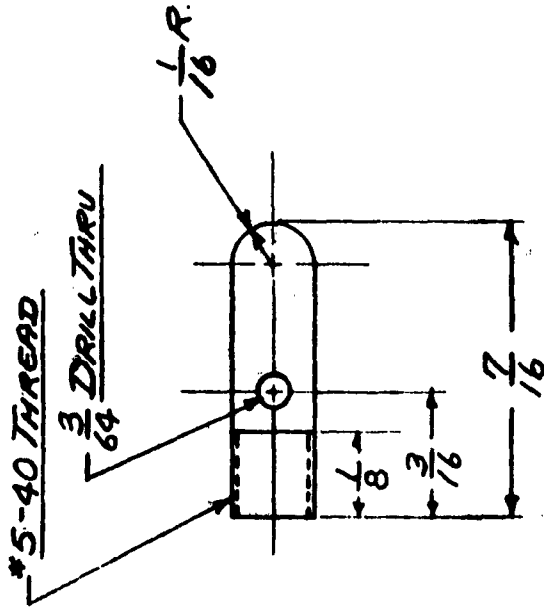

DATE	NO.	ISSUES	REV.	CHK.

TOLERANCES UNLESS OTHERWISE SPECIFIED		FINISH	DATE	NO.	ISSUES	REV.	CHK.
DECIMAL DIMENSIONS ± .005		16	1-26-59				
FRACTIONAL DIMENSIONS ± 1/64		32					
0 - 12" ± 1/32		63					
12" - 24" ± 1/16		125					
24" AND OVER ± 1/8		250					
ANGULAR DIMENSIONS							
ANGLES GIVEN IN DEGREES ± 30 MINUTES							
ANGLES GIVEN IN DEGREES & MIN. ± 5 MINUTES							
MATERIAL	CRS	NO. REQ'D.	ONE	FINISH			
S. A. S. SPEC.				ASSEMBLY NO.	SK-1-59-D-28		
HEAT TREAT				SCALE	4X		
PATTERN NO.				CHECK			
NO. REQ'D.	ONE			DATE	1-26-59		
FINISH							
ASSEMBLY NO.	SK-1-59-D-28						
MATERIAL		SPRING HOLDER ~ SEALING HEAD ASSEMBLY					
S. A. S. SPEC.		ADAPTED TO SEAL CRYSTAL HOLDERS:					
HEAT TREAT		HC-(XM-2)/U & HC-(XM-3)/U					
PATTERN NO.		DIV. ELEC. PRODUCTS DEPT. FALLBROOK					
NO. REQ'D.		CORNING GLASS WORKS					
FINISH		DATE 1-26-59					
ASSEMBLY NO.		SK-1-59-D-17					

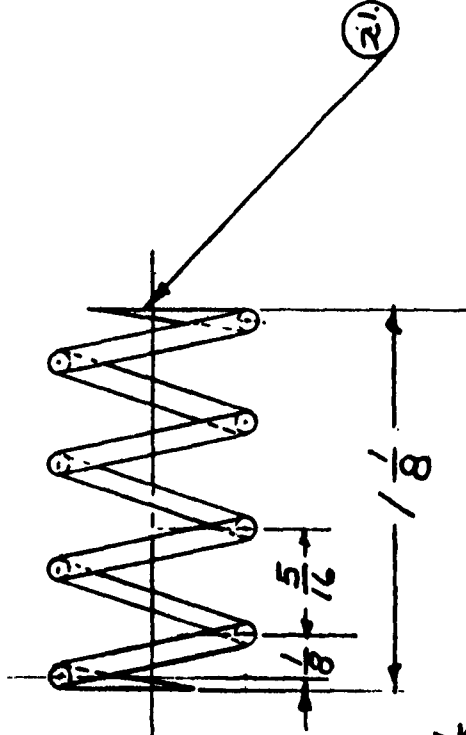
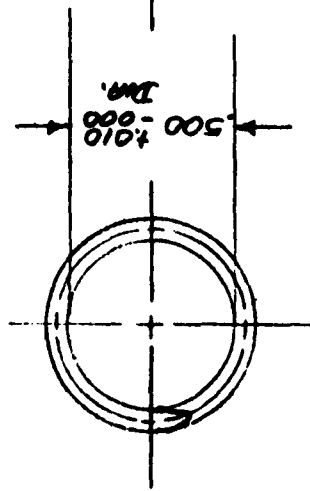

NUMBER OF TURNS 3 1/2

ENDS GROUND

WINDING DIRECTION RIGHT HAND

DATE	NO.	REVISED	APPR.	CHK.

TOLERANCES UNLESS OTHERWISE SPECIFIED	FINISH	FILE	MATERIAL #26 GA. (0.013) MUSIC WIRE	COMPRESSOR SPRING - SEALING HEAD ASSEMBLY
	1			
DECIMAL DIMENSIONS ± .005	16		S. A. E. SPEC.	ADAPTED TO SEAL CRYSTAL HOLDERS:
	32		HEAT TREAT	HC-(XM-2)/U & HC-(XM-3)/U
FRACTIONAL DIMENSIONS 8 - 16" ± 1/64 16" - 24" ± 1/32 24" AND OVER ± 1/16	63		PATTERN NO.	DIV. ELEC. PRODUCTS DEPT. FALL B. BROOK
	125		NO. REQ'D.	ONE
ANGULAR DIMENSIONS ANGLES GIVEN IN DEGREES ± 30 UNLESS OTHERWISE SPECIFIED	250		FINISH	CORNING GLASS WORKS
			ASSEMBLY NO.	SK-1-59-D-28
			CHECK	PFHLL
			SCALE	2X
			DATE	1-5-59
				SK-1-59-D-21

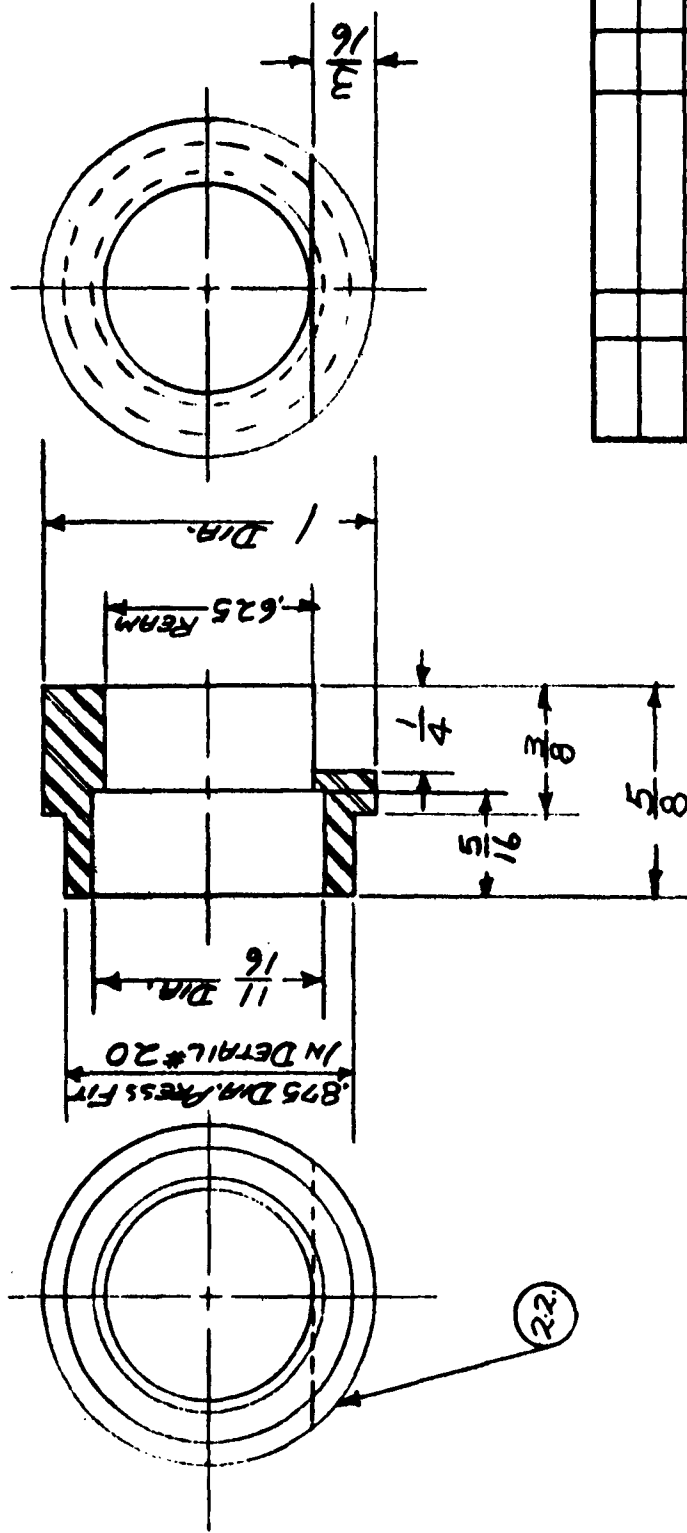

DATE	BY	REVISION	APPR.	CHK.

TOLERANCES UNLESS OTHERWISE SPECIFIED		MATERIAL	CRS	HOUSING BASE ~ SEALING HEAD ASSEMBLY	
DECIMAL DIMENSIONS ± .005		S. A. S. SPEC.		ADAPTED TO SEAL CRYSTAL HOLDERS:	
FRACTIONAL DIMENSIONS 0 - 12" ± 1/64 12" - 24" ± 1/32 24" AND OVER ± 1/16		HEAT TREAT		HC-(XM-2)/U & HC-(XM-3)/U	
ANGULAR DIMENSIONS ANGLES GIVEN IN DEGREES ± 30 MINUTES		PATTERN NO.		DIV. ELEC. PRODUCTS DEPT. FALL BRICK	
ANGLES GIVEN IN DEGREES ± 5 MINUTES		NO. REQ'D.	ONE	CORNING GLASS WORKS	
		FINISH		DRAWN	PF Hill
				CHECK	
		ASSEMBLY NO.	SK-1-59-D-28	SCALE	2X
				DATE	1-5-59
					SK-1-59-D-22

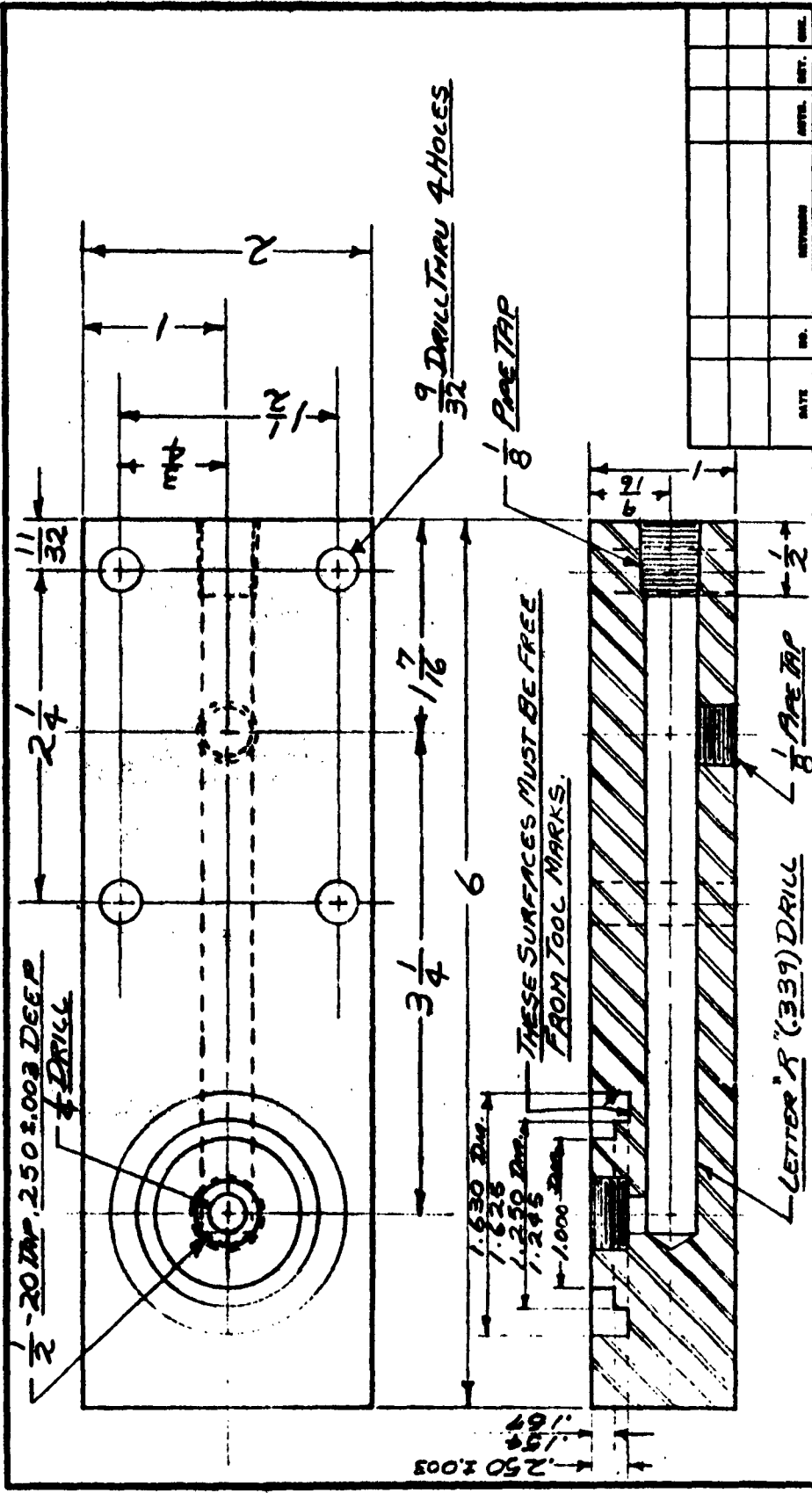

TOLERANCES UNLESS OTHERWISE SPECIFIED	FINISH SPEC.	MATERIAL	SEALING HEAD HOLDER ~ SEALING HEAD ASSEMBLY ADAPTED TO SEAL CRYSTAL HOLDERS:
GENERAL DIMENSIONS ± .004	1	CRS	
FUNCTIONAL DIMENSIONS	DATE	S. A. S. SPEC.	HC-(XM-2)/U & HC-(XM-3)/U
0" - 18" ± 1/64	16	HEAT TREAT	DR. ELEC. PRODUCTS DEPT. FALL BROOK
18" - 36" ± 1/32	32	PATTERN NO.	
36" AND OVER ± 1/16	63	NO. REV'D.	ONE
ANGULAR DIMENSIONS	125	FINISH	
ANGLES OTHER THAN 90° ± 30 MINUTES	250	ASSEMBLY NO.	SK-1-59-D-28
ANGLES OTHER THAN 90° ± 5 MINUTES			

SK-1-59-D-25

CORNING GLASS WORKS

SCALE FULL
DATE 1-30-59

P.F. HILL

ASSSEMBLY NO. SK-1-59-D-28

DATE	NO.	REVISION	APPR. BY	CHK.

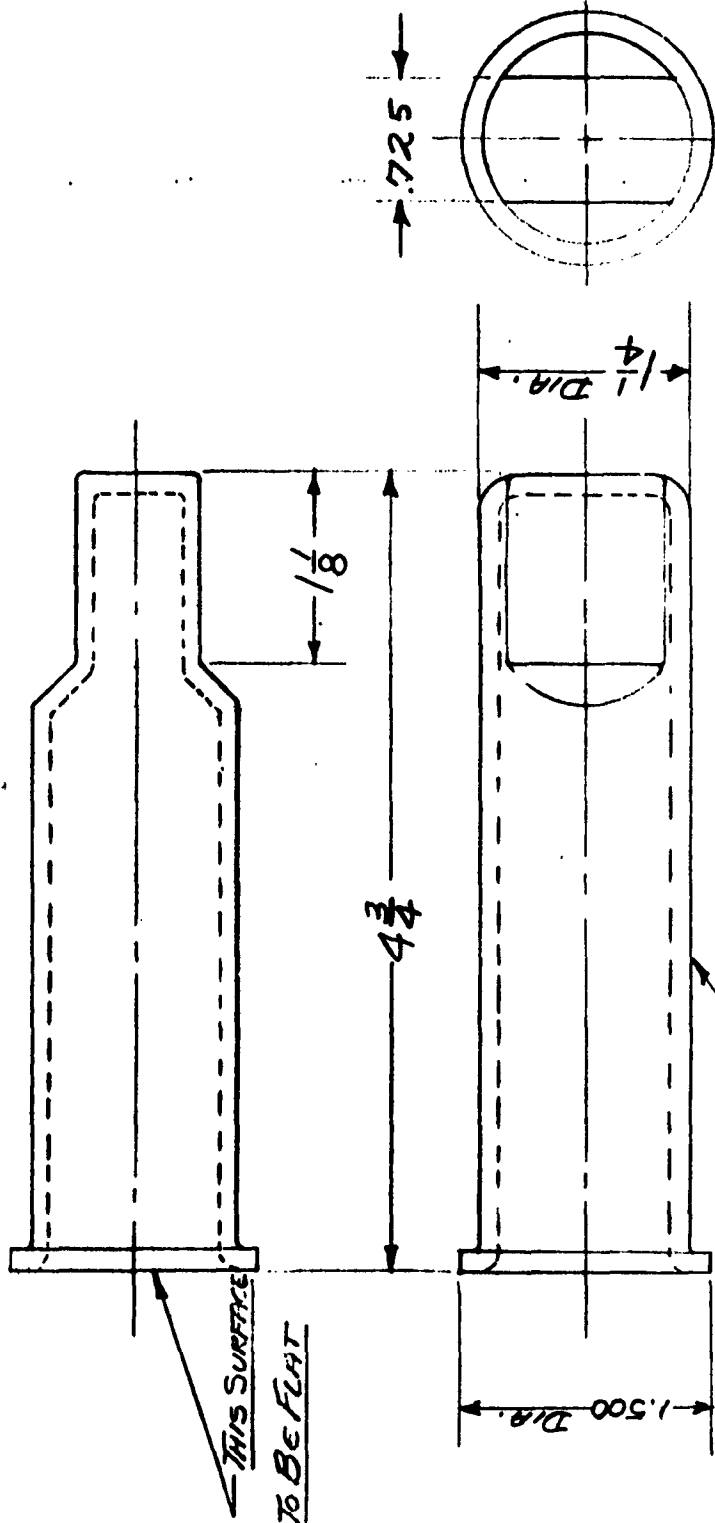

DATE	NO.	REVISION	APPR.	DET.	ORL.

TOLERANCES UNLESS OTHERWISE SPECIFIED		FINISH SPEC.		MATERIAL	BELL JAR ~ SEALING HEAD ASSEMBLY	
DECIMAL DIMENSIONS ± .005		✓	OVER.	PYREX GLASS	ADAPTED TO SEAL CRYSTAL HOLDERS:	
FRACTIONAL DIMENSIONS		16	GRIND		HC-(XM-2)/U # HC-(XM-3)/U	
0 - 12" ± 1/64		32	GRIND		DIV. ELEC PRODUCTS DEPT. FALL BROOK	
12" - 24" ± 1/32		63	BLANKARD		DESIGN	
24" AND OVER ± 1/16		125	BLANKARD		CORNING GLASS WORKS	
ANGULAR DIMENSIONS			MILLED		DRAWN	
ANGLES GIVEN IN DEGREES ± 30 MINUTES			TORN		PF HILL	
ANGLES GIVEN IN DEGREES & MIN. ± 5 MINUTES		250	MILLER		CHECK	
			FILE		SCALE	DATE
					FULL	2-3-59
					SK-1-59-D-26	
					ASSEMBLY NO. SK-1-59-D-28	
					NO. REQ'D. ONE	
					FINISH	
					HEAT TREAT	
					S. A. E. SPEC.	
					PATTERN NO.	

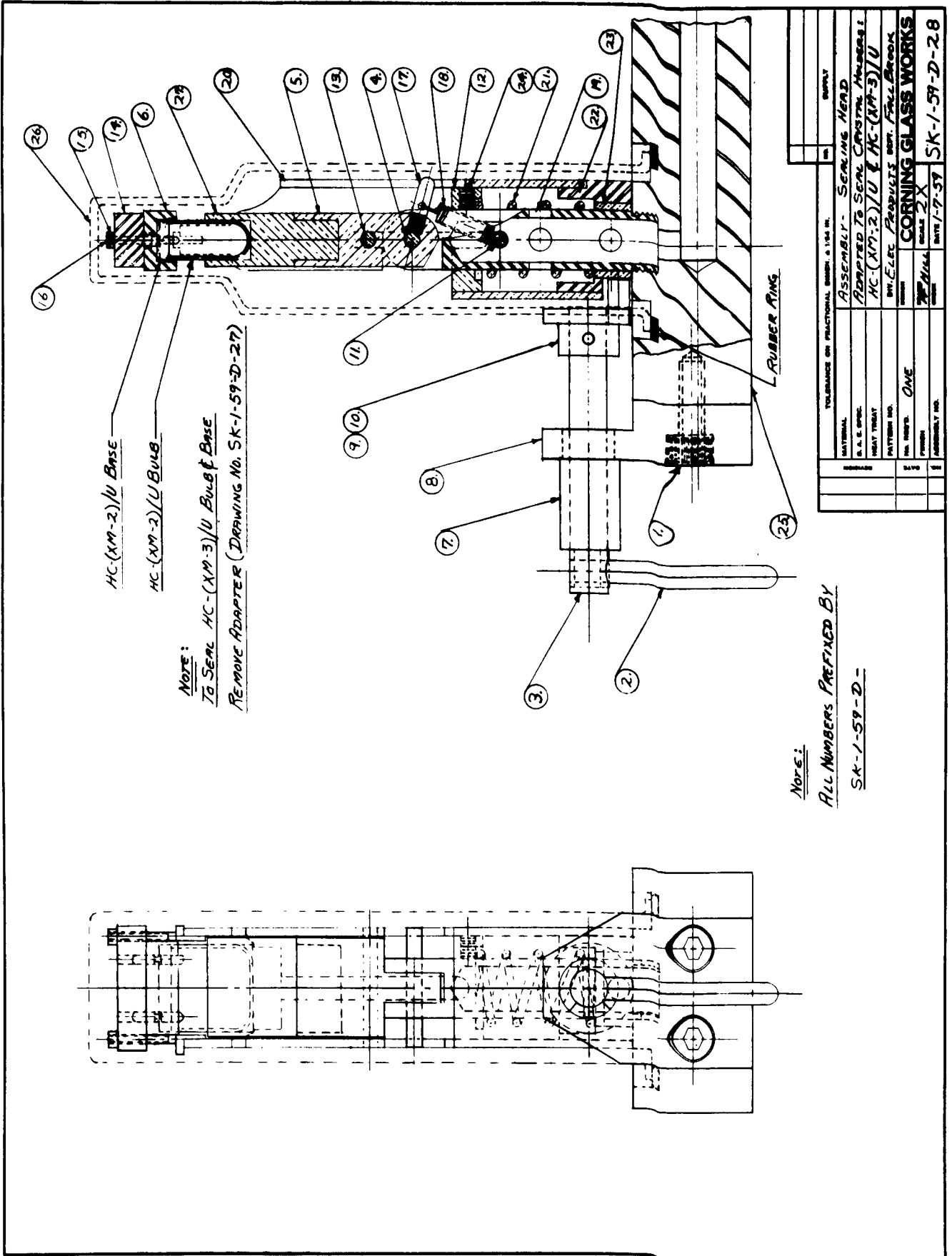

HC-(XM-2)/U Base

HC-(XM-2)/U Bulb

NOTE:
To Seal HC-(XM-3)/U Bulb Base

REMOVE ADAPTER (DRAWING NO. SK-1-59-D-27)

NOTE:

ALL NUMBERS PREFIXED BY

SK-1-59-D-

TOLERANCE ON FRACTIONAL DIMS. & 1/64 IN.		MATERIAL	
ASSEMBLY - SEALING HEAD		A. S. SPEC.	
ADAPTED TO SEAL CORNING HEADS:		HEAT TREAT	
HC-(XM-2)/U & HC-(XM-3)/U		PARTS NO.	
BY ELEC. PRODUCTS DIV. FALL BROOK		QTY. ORDERED	
SCALE 2 X		DATE	
DRAWN BY		CHECKED BY	
APPROVED BY		DATE	
CORNING GLASS WORKS		DRAWING NO.	
SK-1-59-D-28		REV.	