

UNCLASSIFIED

AD 403 880

*Reproduced
by the*

DEFENSE DOCUMENTATION CENTER

FOR

SCIENTIFIC AND TECHNICAL INFORMATION

CAMERON STATION, ALEXANDRIA, VIRGINIA



UNCLASSIFIED

NOTICE: When government or other drawings, specifications or other data are used for any purpose other than in connection with a definitely related government procurement operation, the U. S. Government thereby incurs no responsibility, nor any obligation whatsoever; and the fact that the Government may have formulated, furnished, or in any way supplied the said drawings, specifications, or other data is not to be regarded by implication or otherwise as in any manner licensing the holder or any other person or corporation, or conveying any rights or permission to manufacture, use or sell any patented invention that may in any way be related thereto.

CATALOGED BY ASTIA
AS AD NO. ~~4038-80~~

Biochemical Fuel Cell

Report Nr. 2

Contract Nr. DA 36-039 SC-90878

Task Nr. 3A99-09-001-01

SECOND QUARTERLY PROGRESS REPORT

1 October 1962 to 31 December 1962

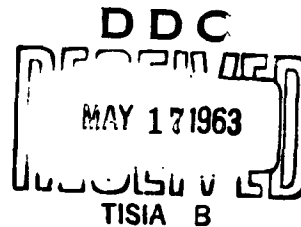

U S. ARMY ELECTRONICS RESEARCH
AND DEVELOPMENT LABORATORY
Fort Monmouth, New Jersey

MELPAR  **INC**

A SUBSIDIARY OF WESTINGHOUSE AIR BRAKE COMPANY

3000 ARLINGTON BOULEVARD

FALLS CHURCH, VIRGINIA

NO OTS

ASTIA AVAILABILITY NOTICES

Qualified requestors may obtain copies of this report from ASTIA. ASTIA release to OTS not authorized.

Biochemical Fuel Cell

Report Nr. 2

Contract Nr. DA 36-039 SC-90878

Task Nr. 3A99-09-001-01

Second Quarterly Progress Report

1 October 1962 to 31 December 1962

Object: The object of this research is to conduct investigations pertinent to biochemical fuel cells. Specifically, the generation of hydrogen by microorganisms, the utilization of this hydrogen, and the usage of readily available hydrogen sources will be studied.

Prepared by: R. T. Foley, G. C. Blanchard, and P. S. May

TABLE OF CONTENTS

	<u>Page</u>
List of Illustrations	3
List of Tables	4
Purpose	5
Abstract	6
Publications, Lectures, Reports, and Conferences	7
Factual Data	8
1. Introduction	8
2. Investigation of Hydrogen-Producing Microorganisms	9
3. Quantitative Analysis of H ₂ , O ₂ , N ₂ , and CO ₂ Gas-Solid Chromatography	25
4. References	37
Conclusions	38
Program for Next Interval	40
Identification of Key Personnel	46

LIST OF ILLUSTRATIONS

<u>Figure</u>		<u>Page</u>
1	Dual Chamber Detector	30
2	Instrument (Schematic)	31
3	Response of Cross Section Detector	32
4	Typical Chromatogram	33
5	Determination of CO ₂	35

LIST OF TABLES

<u>Table</u>		<u>Page</u>
I	Organisms Studied During Second Quarter Screening Program	10
II	Hydrogen Production by <u>Escherichia coli</u>	13
III	Effect of Oxygen on Hydrogen Production by <u>Escherichia coli</u>	14
IV	Hydrogen Production by <u>Aerobacter cloacae</u>	15
V	Hydrogen Production by <u>Pseudomonas sp</u> (Strain G4A)	16
VI	Hydrogen Production by <u>Aerobacter aerogenes</u>	17
VII	Hydrogen Production by <u>Serratia kielensis</u> (<u>kiliensis</u>)	18
VIII	Uncorrected Retention Time at 10 ml/min Flow Rate (25°C)	19
IX	Summary of Hydrogen Production	39
X	Proposed Screening Program for Microorganisms Capable of Producing Hydrogen (3rd Quarter)	41
XI	Fractional Factorial Design	42
XII	Details for Fractional Factorial Design (3rd Quarter)	43

PURPOSE

The purpose of this program is to conduct investigations pertinent to biochemical fuel cells. More specifically, these investigations are devoted to:

1. The study of hydrogen generation by various microorganisms.

This will include a survey of hydrogen-generating microorganisms, the rates at which they generate gases, and the composition of the gases. The latter determinations will be qualitative and quantitative.

2. The consideration of hydrogen utilization.

This will include the consideration of the feasibility of utilizing this microorganism-produced hydrogen either at fuel electrodes in a hydrogen-oxygen fuel cell or directly at bioanodes.

3. The study of proper fuels.

This will include the utilization of such materials as carbohydrates, proteins, and organic acids.

The results of this investigation will be evaluated with respect to the total biochemical fuel-cell program.

ABSTRACT

The experimental investigation of microorganisms capable of producing hydrogen for fuel cell use is described.

Analytical procedures, based on gas chromatography, were developed and refined to the point that a reliable technique for the determination of H₂, O₂, N₂, and CO₂ in microquantities is now in operation.

The microorganisms, Escherichia coli, Aerobacter aerogenes, Aerobacter cloacae, Serratia kielensis (kielensis), Clostridium butyricum, Clostridium butylicum, Pseudomonas sp (strain G4A), and others, were investigated utilizing various substrates.

Of the organisms studied, E. coli, A. aerogenes, A. cloacae, and Pseudomonas sp (strain G4A) appeared to produce more gas than the others examined. These organisms utilized certain substrates more readily than others, producing more gas with a higher percentage of hydrogen. E. coli produced more gas from glucose and maltose than from the other substrates tested. Aerobacter cloacae produced greater hydrogen yields from arabinose and galactose. Pseudomonas sp (strain G4A) under anaerobic growth conditions produced greater hydrogen yields from glucose and formate. Aerobacter aerogenes produced a greater amount of gas (hydrogen) when incubated with fructose and maltose than with the other substrates studied.

PUBLICATIONS, LECTURES, REPORTS, AND CONFERENCES

Conferences: A conference was held at Melpar, Inc., in Falls Church, Virginia, October 25-26, 1962, to review the work done during the first quarter. The U.S. Army Electronics Research and Development Laboratory was represented by Mr. A. F. Daniel and Dr. H. F. Hunger. Melpar was represented by Dr. R. T. Foley, Dr. G. C. Blanchard, and Mr. J. H. Chaudet.

A second conference was held at USAELRDL, Fort Monmouth, New Jersey, December 19, 1962, to consider the statistic design of experiments. The U.S. Army Electronics Research and Development Laboratory was represented by Dr. H. F. Hunger and Mr. J. Perry. Mr. C. Daniel acted as a consultant. Melpar was represented by Dr. R. T. Foley, Dr. G. C. Blanchard, and Mr. B. S. Bernard.

FACTUAL DATA

1. Introduction

The technical work during the second quarter was devoted mainly to screening some of the microorganisms described in the first quarterly report¹ as being potentially able to produce large amounts of hydrogen. Seven organisms and their ability to utilize a selected group of substrates were studied. These organisms included:

Escherichia coli

Aerobacter aerogenes

Aerobacter cloacae

Serratia kielensis (kiliensis)

Clostridium butyricum

Clostridium butylicum

Pseudomonas sp (strain G4A)

The first five mentioned were listed in the first quarterly report¹ as among those to be studied. The latter two were substituted for others which failed to grow. The volume of gas produced by these microorganisms was measured and analyzed by gas chromatography. Techniques to analyze the generated gas quantitatively for H₂, O₂, N₂, and CO₂

were refined during this period; the improved procedure is described in subsequent paragraphs.

2. Investigation of Hydrogen-Producing Microorganisms

A. Introduction

The organisms examined during this report interval were selected on the basis of their potential ability to produce hydrogen metabolically. A survey during the first quarter¹ listed the selections for consideration during this period. These included, besides those listed above:

Photobacterium phosphorlum

Veillonella gazogenes

Veillonella parvula

Peptococcus prevotii

Aeromonas hydrophila

These were not studied because of contaminated source (Photobacterium) and nonviable source cultures (Veillonella, Peptococcus, and Aeromonas). The Pseudomonas culture was substituted for one of the above based on the report of Krichevsky, et al.,² who determined that this organism was capable of high hydrogen yields. Cultures of this strain were obtained through the courtesy of the senior author of that report. Clostridium butyricum was studied because of evidence in literature of its hydrogen-producing capabilities.³

B. Materials and Methods

The organisms studied and the conditions under which they were grown are given in table I.

For the preparation of inocula for the actual gasometric studies, slant cultures (except for the Clostridia) of the appropriate organism were prepared in the designated medium (table I) and grown for 18 hours at the indicated temperature. These temperatures are generally in the optimum range for each of the organisms. After incubation, the slant was washed with 8 ml of trypticase soy broth (Baltimore Biological Laboratories) and 1 ml of the suspension was inoculated into each of 8 plates. Plates were then incubated for 18 hours at the indicated temperature.

Table I
Organisms Studied During Second
Quarter Screening Program

<u>Organism</u>	<u>Medium</u>	<u>pH</u>	<u>Temp</u> (°C)	<u>Oxygen Tension</u>	
				<u>Aerobic</u>	<u>Anaerobic</u>
<u>Escherichia coli</u>	TSA ^a	7.3±	34	X*	X
<u>Aerobacter aerogenes</u>	TSA	7.3±	33	X	
<u>Aerobacter cloacae</u>	TSA	7.3±	35	X	
** <u>Serratia kiliensis</u> (<u>kiliensis</u>)	TSA	7.3±	30	X	
<u>Pseudomonas sp (G4A)</u>	Tryptone ^b	7.3±	25	X	X
<u>Clostridium butylicum</u>	THIO ^c	7.1	30		X
<u>Clostridium butyricum</u>	THIO	7.1	30		X

a. TSA - Trypticase Soy Agar (Balt. Biol. Labs., Baltimore, Md.).

b. Tryptone Medium - See reference 2.

c. THIO - Bactofluid thioglycollate (Difco Labs., Inc., Detroit, Mich.).

* Grown under reduced O₂ tension in screw-cap tubes.

** See paragraph C.6, below.

After incubation, the surface growth on the plates was removed by a bent spatula, or glass rod, suspended in 0.85% saline solution, and transferred to two centrifuge tubes. Cell suspensions were centrifuged, the supernate decanted, and the cells washed three times in saline solution. Packed cells from the final washing were combined into one tube and brought to a volume of 10-12 ml with saline solution. One ml of the suspension was removed for further dilution for counting purposes. The balance was stored in the cold for a maximum of 3 hours until used.

The Clostridia were first grown in thioglycollate broth for 24 hours. Ten ml of this culture were inoculated into AC broth* and incubated at 30°C for 24 hours. Ten ml were transferred from the AC broth into four flasks (100 ml/flask) of thioglycollate broth and stoppered with rubber stoppers. These cultures were incubated for 18 hours at 30°C and then treated as described above.

Bacterial cell counts were made using the Petroff-Hauser chamber.**

Before use, the gas-measuring tubes shown in the first quarterly report were washed with a hot mixture of sulfuric and nitric acids, according to the manufacturer's instructions.***The purpose of the acid was to remove any organic material trapped in the ultrafine pores of the fritted glass disc in the tube. The residual acid was removed by thorough tap and distilled water rinses.

pH values were determined by use of the Beckman Zeromatic pH meter.

*Difco Labs., Detroit, Michigan.

**A.H. Thomas and Co., Phila., Pa., #4101-A.

***Corning Glass Works, #F203, Rev. 3/6.

C. Results and Discussion

1. General

The first quarterly report¹ indicated that the investigations during this quarter would encompass studies on hydrogen evolution by ten microorganisms, each tested with ten substrates. Several problems arose during these studies which interfered with the completion of all of the work that had been planned. Mechanical breakdowns and other difficulties in the gas chromatograph caused delays and left some of the gas studies uncompleted. These difficulties have now been resolved and an improved system, described in paragraph 3, below, is now in use.

Among the organisms listed in the first quarterly report¹, Veillonella gazogenes, Veillonella parvula, Aeromonas hydrophila, and Photobacterium phosphoreum were not studied. The first three were not studied because of the inability to grow them from stock cultures. The last was not included because stock cultures were contaminated with molds. If these can be grown in sufficient quantity for study, they will be included in the screening program during the next quarter. These cultures chosen for study were selected from the list presented in the first quarterly report,¹ which suggested that these organisms were capable of high hydrogen production. This list was based on literature observations made on the respective organisms.

The organisms examined during this period of the study are given in table I. The data collected as the result of the investigations are given in tables II - VIII. The hydrogen production of each microorganism is discussed separately.

2. E. coli studies

The data obtained from studies with E. coli are given in tables II and III. According to the literature⁴, E. coli produces gas from a variety of substrates, including glucose, lactose, maltose, and arabinose. Very little data is available as to the composition of the gases evolved. Results from the present investigations show that gas produced from the first three carbohydrates contain a high percentage of hydrogen. The metabolism of E. coli is known to follow the Embden-Meyerhof-Parnas (E.M.P.) glycolytic scheme;³ thus glucose is metabolized to pyruvate.

Table II

Hydrogen Production by Escherichia Coli (Aerobic*) 34°C, 18 hr., pH 7.4

Substrate (1% conc)	Total gas evolution ml		H ₂ (%)	N ₂ (%)	O ₂ (%)	CO ₂ (%)		X (%)	pH				
1. Glucose	5.5	4.0	79.3	82.7	5.2	5.2	-	-	15.5	12.1	-	5.0	5.0
2. Maltose	5.6	5.7	80	85.7	5	3.6	-	-	15.0	10.7	-	5.9	5.9
3. Sucrose	0.7	0.6	73	73.2	25	25	1.8	1.8	-	-	-	6.6	6.7
4. Lactose	1.0	1.2	84.5	81.5	15.5	18.5	-	-	-	-	-	6.8	6.8
5. Pyruvate	0.9	0.3	70	56.7	20	30	1.0	2.7	5.0	3.6	4.0	6.7	6.8
6. Lactate	No Gas Produced												
7. Malate	No Gas Produced												
8. Arabinose	No Gas Produced												
9. Galactose	No Gas Produced												
10. Starch	No Gas Produced												

Inoculum: 1-4, 6: 1×10^{10} cells5, 7-10: 8.6×10^{10} cells

*Reduced Oxygen tension due to growth in screw-capped tubes.

Table III
Effect of Oxygen on Hydrogen Production by *E. coli* (Aerobic & Anaerobic)
34°C, 18 hrs., pH 7.4

Substrate	Aerobic				Anaerobic									
	Resting cells		Growing cells		Resting cells		Growing cells							
	+0 ₂	-0 ₂	-0 ₂	+0 ₂	+0 ₂	-0 ₂	+0 ₂	-0 ₂						
Glucose														
ml. Total gas	9.5	7	10+	8	1.0	1.0	1.0	10	10	1.0	1.0	10	10	10
H ₂	61	55	58	58	56	49	61	61	61	49	16	3	58	58
N ₂	3	4	3	4	8	38	41	43	33	38	38	45	3	3
CO ₂	40	38	41	43	33	5.2	5.8	5.3	5.7	5.3	5.3	5.4	52	52
pH	5.5	5.2	5.8	5.3	5.7	5.3	5.3	5.3	5.4	5.3	5.3	5.4	5.6	5.6
Galactose														
ml. Total gas	6.2	5.5	6.0	1.8	0.2	1.0	0.2	8	8	1.0	1.0	8	8	6.2
H ₂	62	60	56	52	56	70	56	61	61	70	14	5	65	65
N ₂	4	6	4	16	27	34	43	37	10	20	20	44	5	5
CO ₂	34	34	43	37	10	5.4	5.4	5.3	6.2	6.0	6.0	5.4	38	38
pH	5.3	5.4	5.4	5.3	6.2	5.3	5.3	5.3	6.2	6.0	6.0	5.4	5.4	5.4
Lactose														
ml. Total gas	0	0	1.0	2.0	0	0.1	0	10+	10+	0.1	0.1	10+	10+	10+
H ₂			60	58		64		60	60	64	24	3	54	54
N ₂			4	5		24		3	3	24	7	52	2	2
CO ₂			37	38		7		52	52	7	6.6	5.4	42	42
pH		5.6	5.3	5.3	6.5	6.6	6.5	5.4	5.4	6.6	6.6	5.4	5.4	5.4

Table IV
 Hydrogen Production by Aerobacter cloacae (Aerobic) 35°C, 18 hrs., pH 7.4

Substrate (1% conc)	Total Gas Evolved ml.		H ₂ (%)	N ₂ (%)	O ₂ (%)	CO ₂ (%)	X (%)	pH					
1. Glucose	3.4	2.5	60	5.0	10.	-	0.7	7.5	8.3	27.5	22.7	6.1	6.1
2. Maltose	0.9	1.1	75	20.	20.	1.0	1.0	-	-	-	9.0	6.8	6.8
3. Sucrose	1.5	-	70	23.3	-	0.7	-	-	-	6.0	-	6.7	-
4. Starch	No Gas Produced											6.2	6.2
5. Lactose	1.5	-	72.5	19	-	1.0	-	-	-	7.5	-	6.6	-
6. Pyruvate	-	0.2	-	-	84	-	0.5	-	0.5	12	-	6.4	6.2
7. Lactate	No Gas Produced												
8. Malate	No Gas Produced												
9. Arabinose	3.2	3.9	76.7	6.7	10	-	-	6.7	6.7	10	6.7	6.4	6.4
10. Galactose	4.6	4.3	76.7	6.7	-	-	-	6.7	5.0	10	11.7	6.4	6.3

Inoculum: 1.5 x 10¹⁰ cells/ml

Table V

Hydrogen Production by Pseudomonas sp. (Strain G4A) (Aerobic and Anaerobic Growth)
25°C, 18 hrs., pH 7.4

Substrate (1% conc)	Total gas evolved-ml	H ₂ (%)	N ₂ (%)	O ₂ (%)	CO ₂ (%)	pH Final
Aerobic inoculum						
1.7 x 10 ¹¹ cells						
Formate	0.1	42	58	9	0	7.1
Pyruvate	0.2	62	30	4	8	6.6
Glucose	1.3	54	14	2	25	6.4
Lactose	Trace	0	75	13.5	Trace	7.15
Galactose	0.1	68	26	4	2	6.85
Maltose	3.0	74	9	1	15	6.65
Anaerobic (inoculum)						
7 x 10 ¹⁰ cells						
Formate	6.7	84	6	1	6	7.15
Pyruvate	0.2	52	42	5.5	6	6.75
Glucose	1.9	45	11	1	42	6.45
Lactose	0	0	0	0	0	7.1
Galactose	0.2	52	40	5	3	6.9
Maltose	0.3	54	27	4.5	15	6.6

Table VI

Hydrogen Production by Aerobacter aerogenes 33°C, 18 hrs., pH 7.4

Substrate (1% concentration)	Total gas Evolution (ml)		H ₂ (%)		N ₂ (%)		O ₂ (%)		CO ₂ (%)		Other* (%)		pH	
	a	b	a	b	a	b	a	b	a	b	a	b	a	b
Glucose	8.6	9.1	33	30	4	4	-	-	56	57	-	-	6.6	6.6
Galactose	2.8	2.2	74	70	9	9	-	-	19	22	-	-	6.65	6.65
Fructose	9.0	8.5	40	50	4	4	-	-	53	46	-	-	6.6	6.4
Maltose	6.8	6.0	56	68	4.5	5	-	-	34	28	-	-	6.45	6.45
Lactose	6.0	9.9	37	46	5	4	-	-	54	46	-	-	6.5	6.5
Arabinose	2.1	2.9	28	37	5	5	-	-	75	50	-	-	6.6	6.6

Inoculum 2.26 x 10¹⁰ cells/ml.

Table VII

Hydrogen Production by Serratia kielensis (kiliensis) (Aerobic)
30°C, 18 hrs., pH 7.4

Substrate (1% Conc)	Total gas evolved-ml	H ₂ (%)	N ₂ (%)	O ₂ (%)	CO ₂ (%)	X (%)	pH					
1. Glucose	NO GAS PRODUCED											
2. Maltose	0.3	1.6	50	83.3	20	3.3	1.7	6.6	3.3	-	6.1	6.2
3. Sucrose								7.3	7.3			
4. Starch	NO											
5. Lactose												
6. Pyruvate	GAS											
7. Lactate								7.1	7.2			
8. Malate	PRODUCED							7.2	7.3			
9. Arabinose								6.7				
10. Galactose												

Inoculum 1-5, 8.8 x 10¹⁰ cells

6-10, 12.4 x 10¹⁰ cells

Table VIII

Uncorrected Retention Time at
10 ml/min Flow Rate, (25°C)

Component	Retention Time in minutes
(H ₂ from silica gel)	0.20
H ₂	0.80
O ₂	1.28
N ₂	2.44
CH ₄	4.10
CO ₂	5.50
CO	7.10

Pyruvate is then metabolized to lactate, ethanol, or formate. Stokes³ expresses the equation for glucose fermentation as:

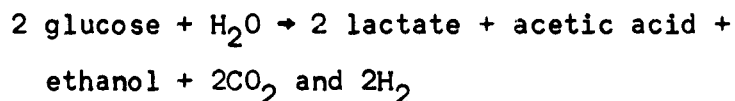

A strain lacking the enzymatic capability to form lactate from pyruvate would evolve more hydrogen because hydrogen is consumed in lactate formation. It may be possible to poison this enzyme selectively without affecting the hydrogenase system and thus increase hydrogen evolution. Maltose and lactose are cleaved by maltase and B-galactosidase, respectively, and the resulting glucose moieties metabolized according to the E.M.P. scheme. Because B-galactosidase is an inducible enzyme, it may be possible to get increased hydrogen production by growth of the organisms on a lactose substrate.⁵ Arabinose did not produce gas although generally E. coli is capable of pentose fermentation.⁴ The pH drop found with this sugar (table II) would suggest sugar utilization. The apparent discrepancy may be caused by strain variations. Malate, one of the Krebs cycle intermediates, was not attacked. One might expect this inasmuch as intact cells of E. coli do not metabolize other citric acid cycle intermediates, i.e., citrate. The lack of utilization does not reflect lack of enzyme capability because disrupted cells readily metabolize these substrates.³

No gas, nor evidence of metabolic activity, was obtained with starch. These results are in agreement with the literature.

Conflicting results were obtained with E. coli incubated with galactose. Cells grown under three different tensions showed three different responses in gas production. The data in table II were obtained from E. coli grown in screw-cap tubes which produced a partially reduced oxygen tension. The data in table III were obtained from E. coli (aerobic) grown in cotton-plugged tubes and E. coli (anaerobic) grown in rubber-stoppered tubes. The variations in oxygen tension could influence the enzyme systems involved in hydrogen production. Further study of the effects of oxygen tension on these enzyme systems would be a value in selecting maximal

conditions for hydrogen evolution. The data found in table III were obtained in a study to ascertain the effect of oxygen on the formation of enzymes responsible for hydrogen evolution and the effect of oxygen on the enzymes after formation. E. coli was grown aerobically and anaerobically; then resting cell suspensions were treated with oxygen-without oxygen. Unwashed cells, treated the same way, were also included. Because the unwashed cells would still continue to grow slightly in the test substrate as the result of nutrient carry-over, they produced larger volumes of gas. The gas composition under all treatments was essentially the same. Much higher gas evolution was observed with cells grown under aerobic rather than anaerobic conditions. These results conflict with those reported in the literature.⁶

The addition of oxygen to the performed enzyme systems had no effect on enzyme activity regardless of the methods of growth or cell preparation. These results agree with the data of Stephenson and Stickland.⁷

The presence, in unwashed cell suspensions, of contaminating materials, such as organic nitrogen, carbohydrates other than the one being tested, and toxic products of metabolism, renders this type of cell preparation unsuitable for systematic hydrogen evolution studies. A cell suspension, washed free of contaminants, provides a system which lends itself to much better control and duplication. After selection of the ideal organism, substrate, and physical factors required for maximum production of hydrogen, the addition of organic nitrogen sources, minerals, and other cofactors should be studied because much greater evolution of gas is found with growing cells.

3. Aerobacter cloacae Studies

The data from these experiments, using Aerobacter cloacae as the test organism, are given in table IV. High levels of hydrogen production were obtained with the carbohydrates tested. Glucose, galactose, and arabinose produced the highest total gas volume under the experimental conditions. According to Bergey's Manual,⁴ starch is not hydrolyzed by this microorganism. Present results concur in these findings. The small volume of gas obtained with pyruvate and the associated high

nitrogen content suggested that air was inadvertently trapped in the system when it was set up. Neither lactate nor malate was utilized. Because good H₂ production was observed with galactose and arabinose, further studies to maximum H₂ production will be conducted during the next quarter with this organism.

4. Pseudomonas sp (Strain G4A).

The isolation and initial studies with this organism were reported by Krichevsky². He found that this organism produced hydrogen by methods similar to the coliform bacteria. The organism for these studies was obtained through the courtesy of Dr. Krichevsky.

Table V gives the data from studies with Pseudomonas sp (strain G4A) conducted with resting cell suspensions prepared from aerobically and anaerobically grown cultures. Previously reported data² with cells grown on glucose under anaerobic conditions showed that they were able to form hydrogen when incubated with glucose and formate, but not when pyruvate was the substrate. Thus, growth on glucose fails to induce enzymes for hydrogen production from pyruvate. Cells grown with pyruvate, however, were able to utilize this compound as a substrate. By comparison, present data show large volumes of hydrogen evolved from glucose and formate and a negligible amount from pyruvate. Total volume of gas evolution on pyruvate was only 0.2 ml of which 52% was hydrogen. This evidence of minimal fermentation of pyruvate and hydrogen formation from glucose and formate is in substantial agreement with the published data. In the same report, washed suspensions of aerobically grown cells produced very little gas or hydrogen with formate. Our results show approximately the same volume of gas from glucose by both growth methods, but considerable lower formate activity in the aerobic cultures.

The 10-fold difference in the gas produced aerobically from maltose compared to that from anaerobic system may be caused by (a) an artifact of the system or (b) actual maltase induction under aerobic conditions. The entire experiment was set up with single tubes; thus, no check on the results could be made. Lactose is not fermented at all and the percentage of gas, particularly nitrogen in the aerobic study is possibly

caused by contamination during sampling. The lack of activity against lactose may be ascribed to the absence of the adaptive enzyme β -galactosidase and/or the suitable permease,⁵ the presence of which would enable entry of lactose into the cell. The results shown in these single-tube studies suggest the need for further investigations. These will be made out in the next quarter.

5. Aerobacter aerogenes Studies

The A. aerogenes fermentation produces CO_2 , H_2 , lactic, acetic, formic, and succinic acids, and 2,3-butanediol as the principal products. The CO_2 -to- H_2 ratio is of the order of 2:1 (3,4) Bergey⁴ reported that arabinose, lactose, and maltose were attacked by A. aerogenes with the production of acid and gas. The results given in table VI agree with the literature data. Of the substrates tested, fructose and maltose produced the largest volume of hydrogen. Glucose and lactose also produced high hydrogen yields. The small total volume of gas from galactose, accompanied by a relatively high hydrogen content, may be caused by the lack of induced enzyme or suitable conditions required for its metabolism. It appears that the gas ratio CO_2 to H_2 produced from glucose approximates that found in the literature.⁴ More CO_2 would be liberated if the final pH were lowered. The effect of the final pH on the final gas volume should be further studied. This organism appears to be one of the better hydrogen producers and will be studied further during the next quarter.

6. Serratia kielensis (kiliensis), Studies

According to the literature,⁴ Serratia kielensis (kiliensis) was expected to produce acid and gas from glucose, lactose, and sucrose. Bergey⁴ also indicates that some confusion exists as to the actual nature of Serratia kielensis. In fact, the description applies to a particular isolated strain. The data reported in table VII show hydrogen production only when maltose was used as the substrate. The enzyme pattern of this organism resembles E. coli³ and, therefore, one would expect glucose utilization. The reasons for the apparent lack of activity may be ascribed to (a) a strain different from that described in the literature and (b) the lack of optimum conditions for growth and enzyme development. Because of poor gas yield and the questionable nature of this strain, no further studies are intended.

7. Clostridium butylicum Studies

The major products of clostridial metabolism are butyric acid, acetone, butanol and ethanol, and large amounts of CO₂ and hydrogen. Substrates utilized include glucose, xylose, sucrose, lactose, and mannitol.^{3 4} Resting-cell suspensions, prepared from thioglycollate-grown Clostridium butylicum, produced very small volumes of gas from maltose and glucose. These results appear to be in contradiction to previously reported data.³ Cell suspensions from thioglycollate-grown cultures were "gelatinous" and this matrix may have interfered with enzyme activity. Abundant gas was evident in growing thioglycollate cultures, but with resting cells, only 0.1 ml of gas was produced. Culture methods will be improved so that the full effects of the known enzyme systems can be measured with active resting-cell preparations.

According to the literature,³ Clostridium butyricum produces about 235 Moles of hydrogen from 100 Moles of glucose, indicating that this organism is about five times more effective as a hydrogen producer than Cl. butylicum. It is planned to continue studies on these organisms.

3. Quantitative Analysis of H₂, O₂, N₂, and CO₂ by Gas-Solid Chromatography

A. Introduction

Several gases are known to be evolved by bacteria from various substrates. The principal gas of interest in this program is H₂, with interest also being manifest in CO₂, and N₂. The three pure gases, H₂, N₂, and CO₂, are readily analyzable with a single column of silica gel. A trace of O₂ found in most samples is not resolved from N₂ on the silica gel column; as a result, a silica gel column cannot be used for the N₂ analysis. A column which will satisfactorily resolve O₂ from N₂ at room temperature is one made up of the synthetic zeolites, or molecular sieves.* Molecular sieve columns, however, irreversibly absorb CO₂ at room temperature. On the other hand, molecular sieve can be used for the analysis of all the gases of immediate interest if the column is temperature programmed from room temperature to about 300°C. Temperature-programming adds substantially to the cost of gas chromatographic equipment and to the time of analysis in this application. As a result, temperature programming was considered to be unsatisfactory. As short an analysis time as possible was desired because as many as eight to ten samples per hour must be analyzed for the time-of-culture studies to be valid.

The room-temperature analysis of gas samples containing H₂, N₂, and CO₂ can be made in several ways. For example, an arrangement in which the sample is split, diverted through parallel columns of silica gel and molecular sieve, and then recombined has been used.⁸ Another alternative is to use a silica gel and molecular sieve column in series with each column being followed by a detector. The silica gel column would resolve CO₂ from H₂, O₂, and N₂, but it would pass the last three gases as an unresolved peak. The second column, the molecular sieve column, would irreversibly absorb the CO₂ from the first column, but it would pass and resolve H₂, O₂, and N₂. The detectors after each column sense the gases as they are eluted from the columns.

* Product of Linde Co., Division of Union Carbide and Carbon, New York, N.Y.

A third alternative is to use two separate columns with either one or two detectors and two samples injections. A silica gel column for the CO₂ analysis and a molecular sieve column could be used for the analysis of the remaining gases. Each of these systems was investigated and the results are described in subsequent paragraphs.

Several detection systems are available for the analysis of these permanent gases: (a) the thermal conductivity detector which utilizes the change in electrical resistance of a heated element when exposed to gases of differing thermal conductivity; (b) the ionization quench detection method of Willis⁹ in which impurities in the carrier gas are ionized by a beta source to provide a high current background, (c) electron mobility detector¹⁰ which is similar to the ionization quench but utilizes a pulsed anode and pure argon carrier gas; (d) thermionic emission¹¹ utilizing electron energies below the ionization potential of the helium (24.6 ev) carrier but above H₂ (15.6 ev); and (e) cross-section ionization detection in which a beta source ionizes the gases of interest to produce an increase in current through the detector.

Neither pulsed anode electron mobility nor thermionic emission were considered for this application because of the additional electronic components and greater complexity of the systems.

B. Experimental

This section concerns the development of an optimum column configuration and detectors for analyzing for H₂, CO₂, N₂, and O₂ associated with bacterial growth. For convenience, the discussion is divided into a consideration of the detectors investigated and the column configurations that could be used with them. In the following section, a summary is given of the adopted technique for determining the gases of interest.

Thermal Conductivity. The thermal conductivity detector was investigated first. This detector has the advantages of relatively low cost, dependability, stability, and large linear range. Its principal disadvantage is that two carrier gases are required: hydrogen or helium (high conductivity gases) for the analysis of O₂, N₂, and CO₂, as well as a gas such as N₂

or argon which has a low thermal conductivity for the analysis of H_2 . The analysis of hydrogen in a helium carrier is not too feasible because their thermal conductivities are approximately the same. In addition, anomalous hydrogen responses are obtained at times. Argon may be used as the carrier for hydrogen detection, but its use leads to chromatograms for the mixture with both positive and negative responses, the response being dependent upon the thermal conductivity of this carrier and the gases to be detected.

Accordingly, essentially two complete systems (carrier gases, columns, detectors) would have to be used and at least three samples taken for each analysis if thermal conductivity detectors were used: one on silica gel for CO_2 analysis using helium as a carrier gas and one on the molecular sieve column using helium for O_2 and N_2 . A third sample must then be used with molecular sieve with argon as a carrier gas for the analysis of H_2 . Only two injections would be required if a series column, two detector arrangement were used for CO_2 , O_2 , and N_2 .

Ionization quench detector. This detector is a parallel plate, micro cross-section detector built in this laboratory and operated at high voltage (600 to 1200 volts). The optimum voltage is dependent upon the spacing of the electrodes, pressure, and the level of impurity in the carrier gas. It operates most satisfactorily near the voltage at which arcing across the electrodes occurs. Unfortunately, if the level of impurity should increase because of flow-rate increase, or from other causes, arcing will occur.

This detector requires a regulated high-voltage power supply capable of maintaining relatively high currents through the detector. Batteries are not satisfactory because of the high current drain. Preliminary experiments demonstrated that because of this high current, no electrometer is required. The recorder signal can be developed by placing a suitable resistor in series with the power supply and the detector. The linear range is quite small and is dependent upon the background current level.

This detector was used for determining the optimum column lengths for the molecular sieve and silica gel columns in parallel. The optimum lengths found were ten inches for

silica gel of 200/230 mesh particle size, 1/8" OD tubing, and 25 inches for molecular sieve of 100/120 mesh particle size, 1/8" OD tubing.

A parallel arrangement in which splitting of the gas stream occurs following the injection port is satisfactory for single gases; calibration curves are linear over a reasonable range and reproducible range and reproducible. When gas mixtures are injected, however, differential splitting occurs and the calibration is no longer valid. This is to be expected because of the great relative mass difference existing between H₂ (mass 2) and CO₂ (mass 44). In an effort to overcome this problem, a six-inch silica gel column was inserted after the injection port, but preceding the silica gel-molecular sieve parallel arrangement. In this way, partial separation of H₂ and CO₂ from O₂ and H₂ occurs before splitting. This helps but does not completely eliminate differential splitting. As a result, parallel columns were abandoned and a series arrangement used with one detector between the silica gel and molecular sieve columns and one following the molecular sieve columns. The quench detector would not operate satisfactorily at the pressure existing between the two columns because a much higher voltage was required to establish the necessary background current. Moreover, at these high voltages, arcing occurs. The quench detector was, therefore, abandoned for this application.

Cross-Section Ionization Detector. The cross-section detector operates more satisfactorily at high pressures than it does at one atmosphere. It has a linear response over a large dynamic range. The limit of detection sensitivity is dependent upon the quality of electrometer amplification and the purity of the carrier gas as well as the detector design. The response of the cross-section detector is directly proportional to the activity level of ionizing radiation.

A molecular sieve trap preceding the injection port provides helium of sufficient purity for this analysis. A battery (45 or 90 v) is sufficient to operate the detector and provides greater stability than is normally obtained with AC-operated DC power supplies.

A special two-chamber cross-section ionization detector was built and found to operate satisfactorily. This was used in connection with the series arrangement of columns. This detector utilizes one collector electrode and two polarizing electrodes (see figure 1). In the series arrangement of columns, one chamber is used for the detection of the effluent from the silica gel column, the first column. The second chamber is used for the detection of the effluent from the molecular sieve column, the second column. A flow restrictor on the exit of the detector is used to increase the pressure.

This series arrangement with the spectral cross-section detector is the most satisfactory. It is shown diagrammatically in figure 2. It is preferred to arrangements with either the conductivity or ionization quench detectors which can be utilized under less favorable conditions. The simplicity and rapidity of analysis with this system are quite appealing. With the arrangement of figure 2, analysis for H_2 , O_2 , N_2 , and CO_2 can be performed in less than eight minutes.

The response of the cross-section detector is reasonably linear for all the gases of interest, except H_2 , as shown in figure 3. Hydrogen is linear up to about 16 μ l sample size under the described conditions, which is adequate for analysis. Above 16 μ l, peak reversal occurs. Peak reversal for H_2 was one of the reasons the thermal conductivity detector was rejected. However, the simplicity of construction of this dual-chamber cross-section detector and the fact that no detector thermostating is required, make it more advantageous to use in this application.

The lowest noise level and, accordingly, the highest sensitivity were obtained by enclosing the column, detector, and polarizing battery in a metal box, and by utilizing low-noise Microdot* feedthrough connectors and shielded conductors.

Figure 4 shows a typical chromatogram showing the separation of the gases of interest. Methane and CO have also been separated from H_2 , O_2 , N_2 , and CO_2 in this arrangement. At a flow rate of 10/minute, the retention time for each component is indicated in table VIII. Under these conditions, up to 2.5 ml of each pure gas (except H_2) can be injected into the system.

* Microdot, Inc., South Pasadena, California.

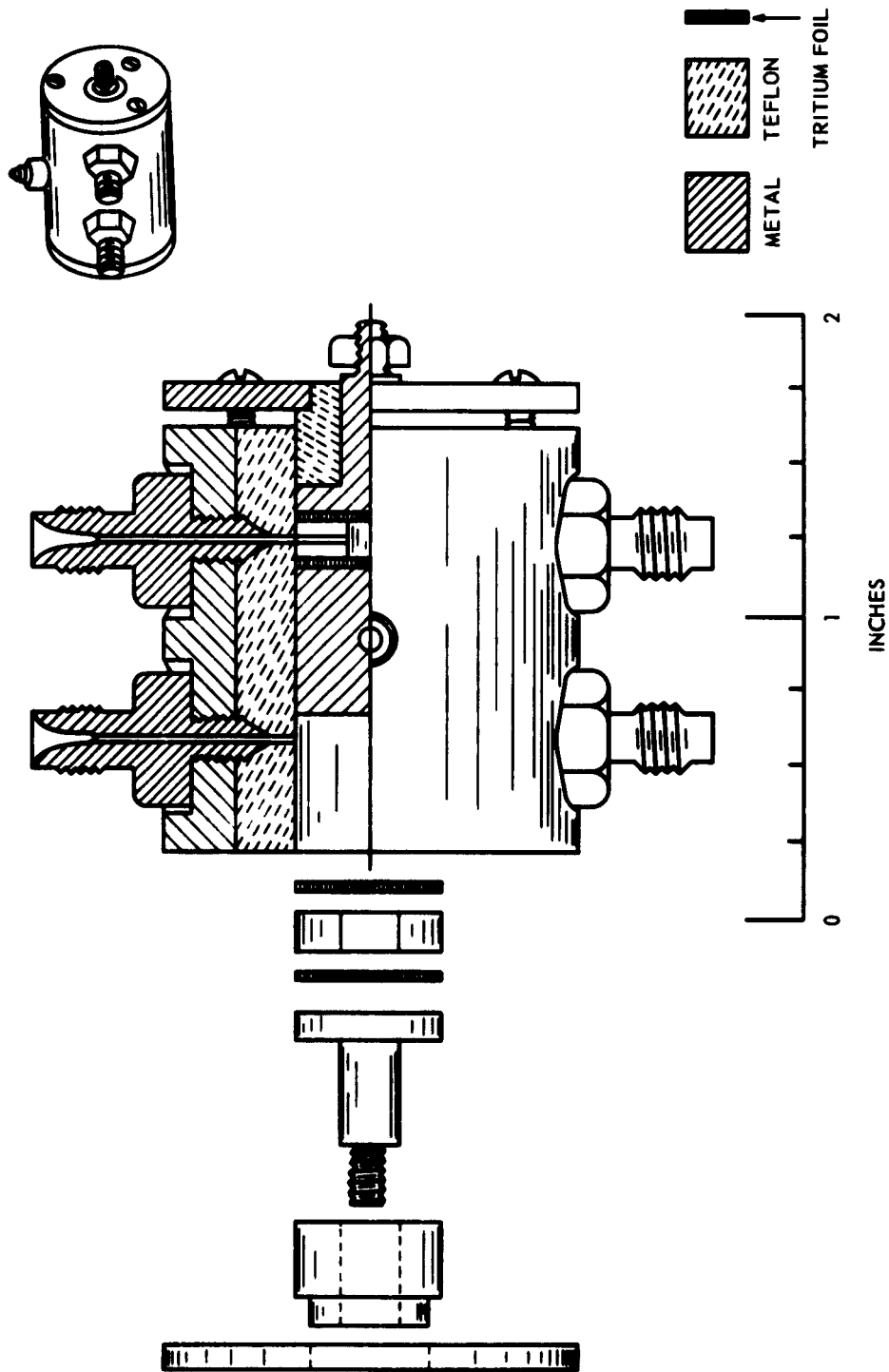

Figure 1. Dual Chamber Detector (1/4 section, semiexploded view)

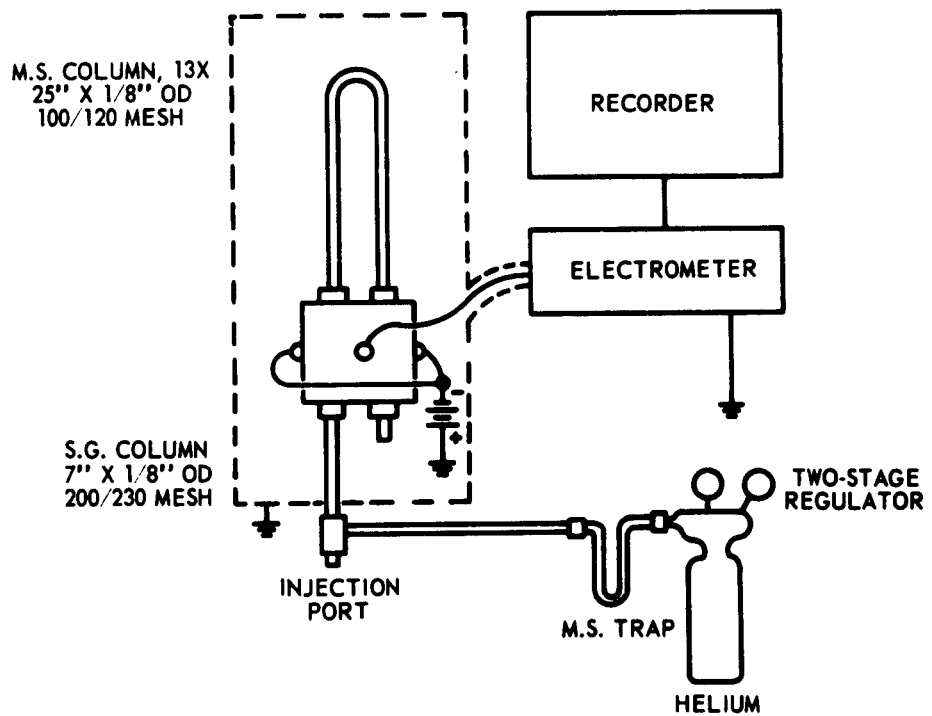

Figure 2. Instrument (Schematic)

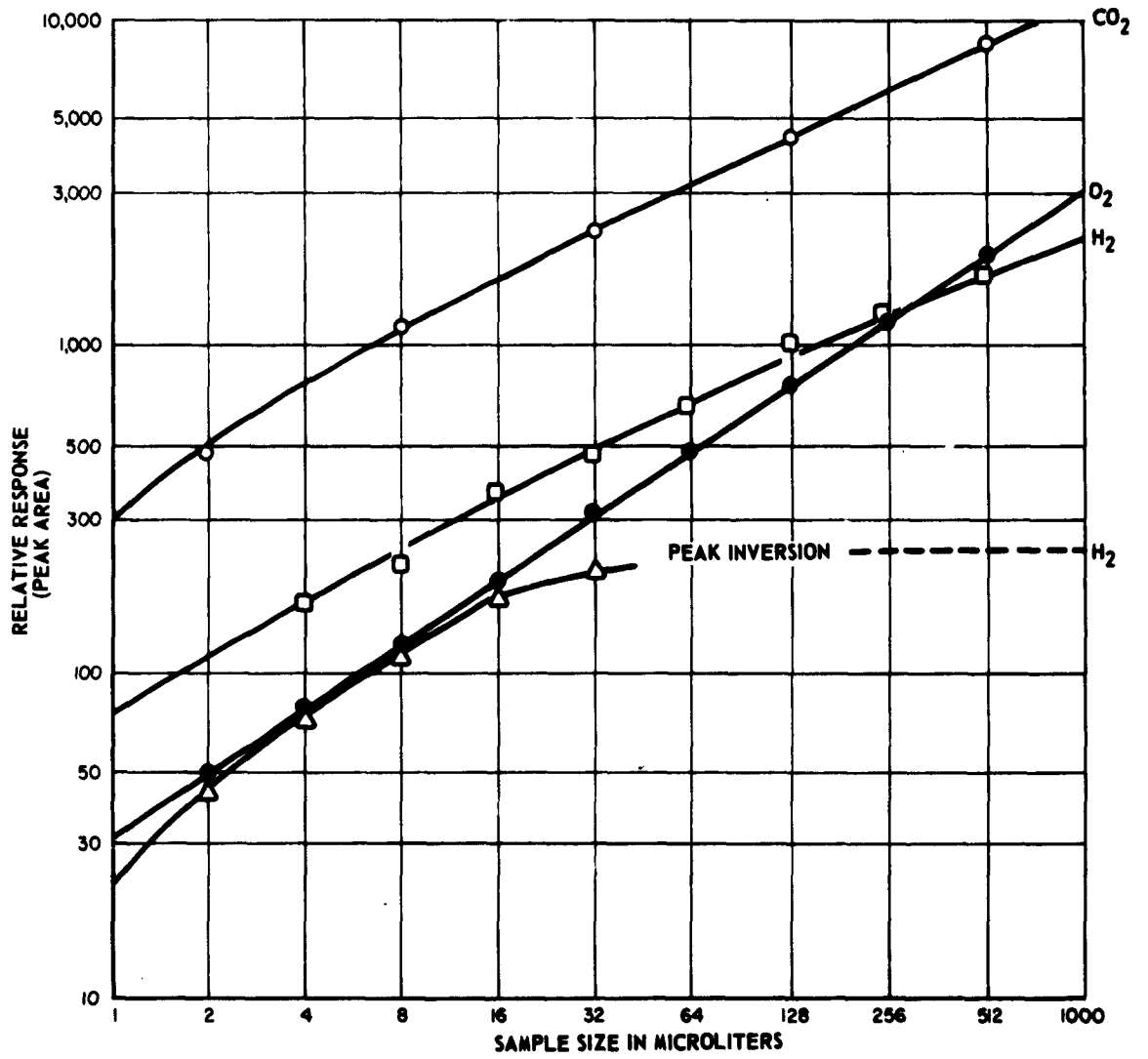

Figure 3. Response of Cross Section Detector

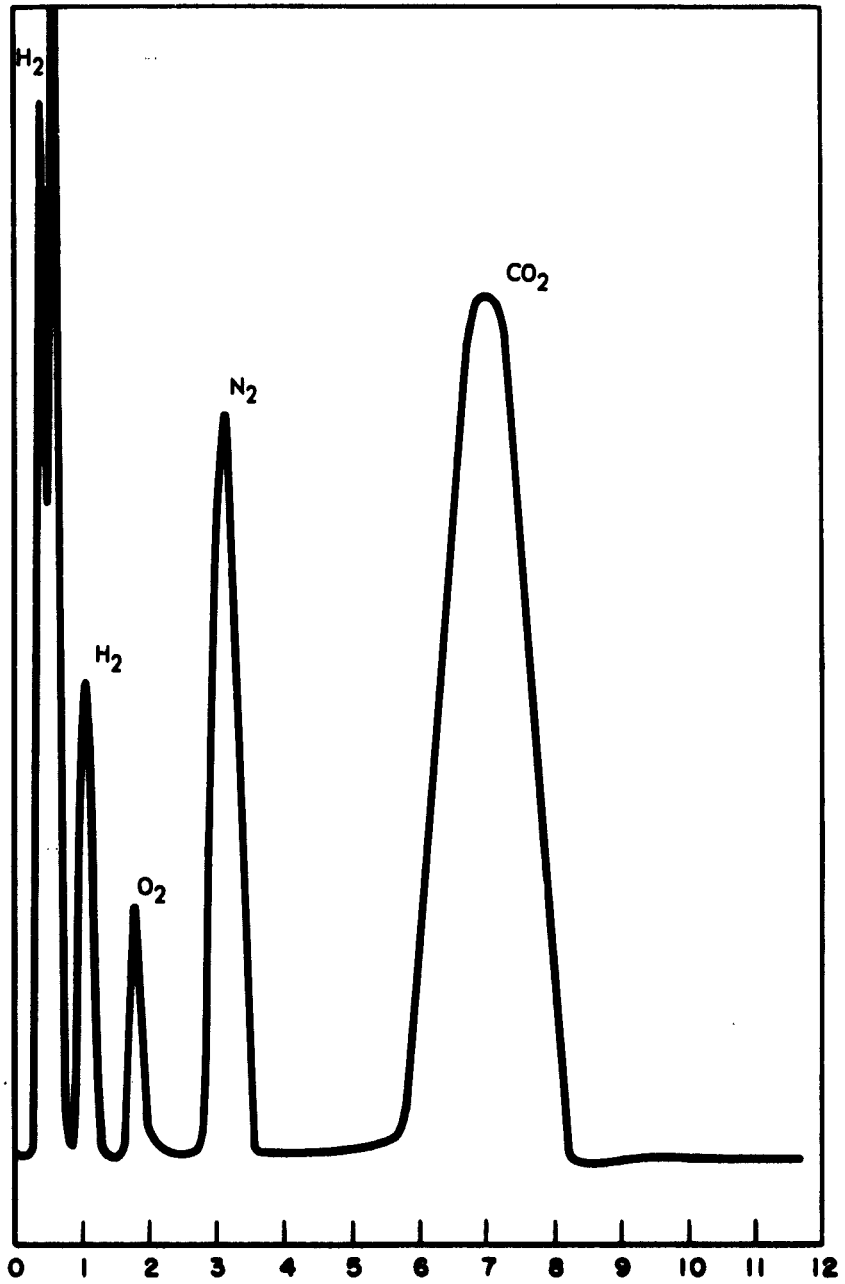

Figure 4. Typical Chromatogram

It has been demonstrated that the sensitivity obtainable with this system is sufficient to allow the determination of CO₂ in air at the normal concentration level of 0.03 to 0.05% by injecting less than 100 microliter samples of air into the system (signal-to-noise level of 5:1). Figure 5 shows this. Figure 5a shows the level of CO₂ in laboratory air (about 0.08%) for a 100 μ l air injection, while figure 5b shows the CO₂ level of a typical exhaled breath for a 100 μ l injection. A commercial gas chromatographic electrometer (Barber-Coleman) was used as a signal amplifier.

C. Method

In general, overall procedures related to sample injection, instrument calibration, and optimum conditions for operation are summarized in this section. The series arrangement of silica gel and molecular sieve columns, together with cross-section ionization detectors, has been found to be excellent for the detection and analysis of H₂, O₂, N₂, and CO₂. Detection sensitivity is at the parts-per-million level with this system.

The sample, supplied as a pocket of trapped gas in a septumsealed growth chamber, is extracted with a 10- or 50- μ l syringe. Best results were obtained utilizing Hamilton Microliter Syringes* with silicone-oiled metal plungers. The use of silicone oil on the plungers was found to be more reliable than using Hamilton Teflon-tipped, "gas-tight" syringes of this capacity. Generally, a 20- μ l sample size is used. The extracted gas is immediately transferred and injected into the chromatographic column through a rubber septum. For best results, duplicate injections are desired for each sample. A reproducibility of $\pm 0.1\%$ is normally obtained. The concentration of gas is obtained by measuring the response peak height in the chromatogram and multiplying this height by the peak width at 1/2 the peak height. This value is then compared with a calibration curve for the particular gas.

The cross-section detector is very reproducible and a single calibration curve for each gas is usually sufficient. Some drift does occur, however, with most electrometers and the change in the impurity level in the helium carrier gas may affect the detector response. Therefore, it is desirable to

*Product of the Hamilton Company, Inc., Whittier, California.

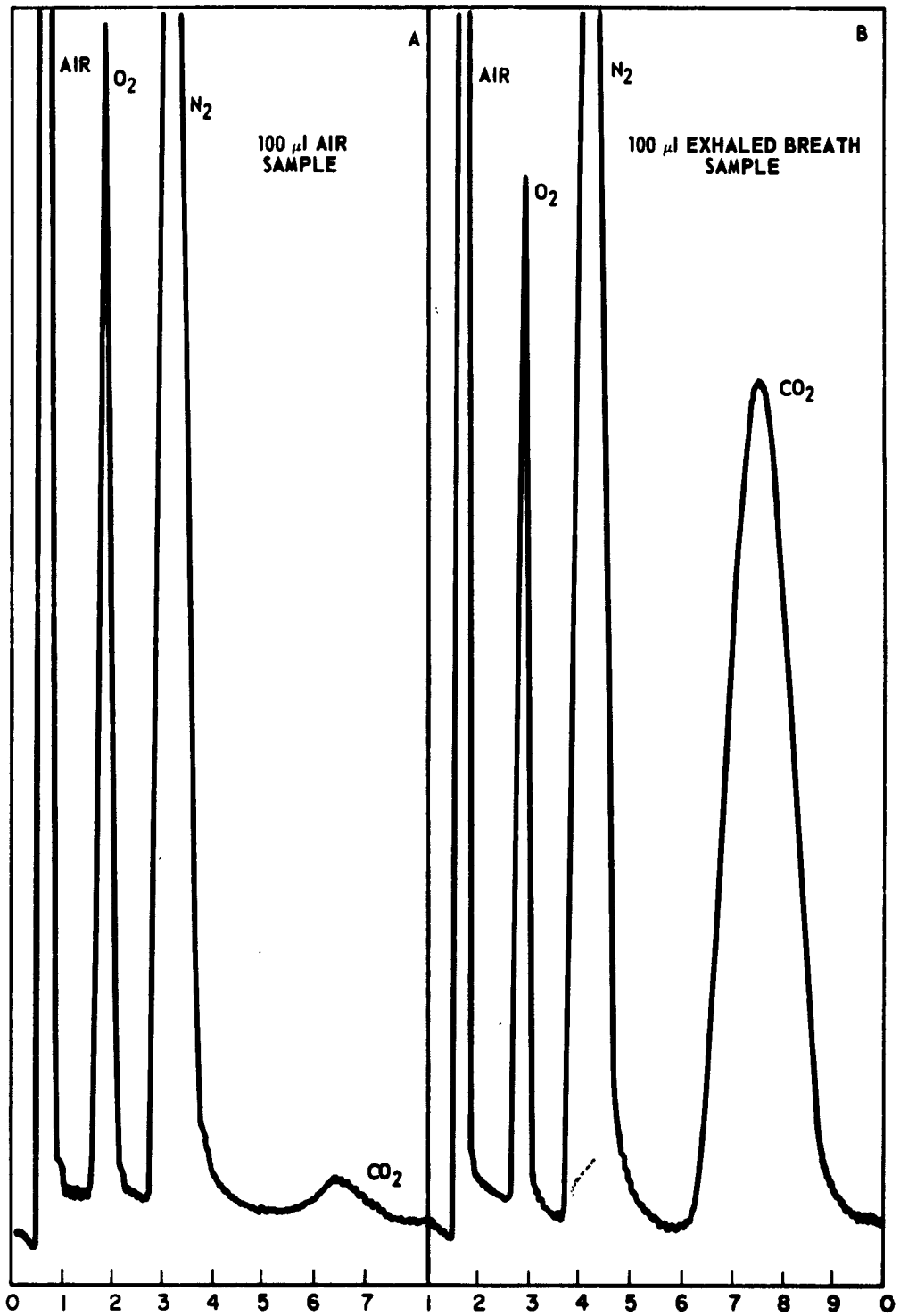
Figure 5. Determination of CO₂

verify the calibration curves during each sampling period by injection of an air sample. If the O₂ and N₂ response vs. sample size provide higher or lower values than the calibration curve, samples of the other gases of interest should also be checked and new calibration curves obtained. Generally, three points for each gas are sufficient. The same syringe used for sampling should be used when making calibration curves.

Best results and more satisfactory service are obtained by leaving the electrometer and carrier gas on during the entire operation. Up to 1 hour may be required for electrometer stabilization following complete shutdown. The detector polarizing battery should be replaced every six months. Its life expectancy under continuous use is the same as its shelf life because of the low current drain in this unit. At a flow rate of 10 ml/minute, a cylinder of helium (size 1A) will last more than one year. Injection-port septums* should be replaced after approximately 50 injections, or when leakage is apparent.

With daily use, the molecular sieve and silica gel columns will need to be reconditioned after three to six months. As long as satisfactory separation of each component is obtained, reconditioning is not necessary. If water should accidentally be injected into the column, reconditioning will be required more often. The columns are connected to the detector and the injection port with Swagelok** fittings. To ensure zero leakage, these fittings have been backed with Teflon sheet. When reconditioning these columns, this Teflon must be removed. The columns are reconditioned at a temperature of 300°C for two or more hours with dry helium passing through the columns. Both columns may be conditioned at the same time, provided the helium flow is directed through the molecular sieve column first and then through the silica gel column. After conditioning, new Teflon should be placed in the fittings during reassembly.

*Burrell Corporation, Pittsburgh 19, Pa.

**Product of Crawford Fitting Co., Cleveland 10, Ohio.

4. References

1. Foley, R. T., and Blanchard, G. C., Biochemical Fuel Cell, Rept. Nr. 1, Contract Nr. DA 36-039 SC-90878, 1 July 1962 to 30 September 1962.
2. Krichevsky, M. I., et al., J. Biol. Chem. 236, 8., 2520 (1961)
3. Gunsalus, I. C., and Stanier, R. Y., (Ed.), "The Bacteria," Vol II, Academic Press, N. Y. (1961)
4. Breed, R. S., et al., "Bergey's Manual of Determinative Bacteriology," 7th Ed., Williams and Wilkins Co., Baltimore (1959)
5. Lamanno, Gauo Mallette, M. F., "Basic Bacteriology," 2nd Ed., Williams and Wilkins, Baltimore, (1959)
6. Gest, Howard, Bact. Rev., 18, 1: 43 (1954)
7. Stephenson, M. and Stickland, L. H., Biochem. J. 26: 712-724 (1932)
8. N. Brenner and E. Cieplinski, Annals of the New York Academy of Sciences, 72, 705-713 (1959)
9. V. Willis, Nature 183, 1754 (1959).
10. J. E. Lovelock, Nature 187, 49 (1960)
11. S. A. Ryce and W. A. Bryce, Can. J. Chem. 35, 1293 (1957)
12. Davies, O. L. (Ed.), "The Design and Analysis of Industrial Experiments," Oliver and Boyd, Edinburgh (1954)
13. Colowick, S. P. and Kaplan, N. O., "Methods in Enzymology," Vol. I. Academic Press, N. Y. (1955)
14. Somogyi, M., J. Biol. Chem. 195: 19-23 (1952)

CONCLUSIONS

In this phase of the program, it may be concluded that the gas chromatographic method has been sufficiently developed and refined so that a reliable method is available for quantitatively measuring the gases produced by various microorganisms.

The hydrogen-producing capacities of E. coli, A. aerogenes, A. cloacae, Pseudomonas sp (Strain G4A), Serratia kielensis and Cl. butylicum, utilizing selected substrates, have been investigated. From the results of these studies, summarized in table IX, and by comparison with previously reported observations, the following conclusions may be made:

(a) E. coli produces the highest per cell yield of hydrogen when incubated with glucose and maltose. Following in order are, A. cloacae with galactose, arabinose, and glucose; A. aerogenes with fructose, maltose, and lactose; Pseudomonas sp Strain G4A, (anaerobic), with formate.

(b) The oxygen tension during growth, when the hydrogen evolving enzymes are being synthesized, determines the amount of hydrogen liberated by resting-cell suspensions. This parameter will have to be evaluated for each organism to be screened.

(c) The addition of oxygen to preformed enzyme (resting-cell suspensions) does not diminish enzymatic hydrogen production.

(d) The media for the growth of strict anaerobes, especially Clostridium, should be one that would support enzyme formation or eliminate inhibitors. Very little hydrogen production was observed with cells grown on thioglycollate medium.

(e) Additional screening studies are required to select efficient hydrogen-producing enzyme-substrate complexes.

(f) The optimum conditions for maximum hydrogen production should be determined.

Table IX

Summary of Hydrogen Production
(10⁻¹² ml H₂ Produced/Cell)

Substrate	Escherichia coli Table II		Aerobacter Aerogenes Table VII		Aerobacter Cloacae Table IV		Pseudomonas sp (G4A) Table V			
	(1)	(2)	(1)	(2)	(1)	(2)	(1)	(2)		
Glucose	437		331		120	110	140	100	4	
	(1)*	(2)							12	
Galactose		(1)		(1)	90	50	230	220	0.4	
		(2)		(2)					1.4	
Fructose		(1)		(1)	160	190				
		(2)		(2)						
Maltose		(1)	448		488	162	177	45	51	13
		(2)								2.3
Lactose		(1)	85		98	100	200	72		
		(2)								
Arabinose		(1)			26	48	160	200		
		(2)								
Formate		(1)							0.25	
		(2)							80	
Sucrose		(1)	51		44					
		(2)								
Pyruvate		(1)	8		2				0.73	
		(2)							1.4	

PROGRAM FOR NEXT INTERVAL

The program for the next interval will be conducted in two areas. The screening program, collecting and investigating organisms capable of evolving large volumes of hydrogen, will be continued, but substrate selection will be modified to each organism. An experimental design, called the Fractional Factorial Design, will be instituted in an attempt to learn optimum conditions for maximum hydrogen evolution. Organisms selected from the screening program will be subject to intensive studies of the principal factors involved in enzyme activity.

The proposed outline of organisms and substrates to be studied and re-evaluated in the screening portion of the program for the next interval is given in table X. The continued study of the Clostridia is warranted because these organisms have been reported to be good hydrogen evolvers. It may be impossible to screen these organisms in the absence of organic nitrogen sources. This factor will be investigated during the next quarter.

The Fractional Factorial Experimental Design will be set up according to the pattern suggested by Mr. C. Daniel.* Analysis will follow the procedures recommended by Davies.¹² The design will consider seven factors at high and low levels. No interaction, or negligible interaction between the factors, will be assumed.

The factors to be examined are:

Oxygen tension

Agitation

pH

Temperature

Bacterial cell count

Substrate concentration

Buffer concentration

*Consultant in statistics for USAELRDL.

Table X

Proposed Screening Program for Microorganisms Capable of Producing Hydrogen
(3rd Quarter)

Substrates	Organisms										
	Clostridium Butyricum (1)	Clostridium Butylicum (1)	Photobacterium Phosphoreum (1)(2)	Pseudomonas sp(G4A) (1,2)	Veillonella Gazogenes *(1)	Veillonella Parvula *(1)	Aeromonas Hydrophila (1)(2)				
Glucose	X	X	X	X		X					X
Maltose	X	X	X								X
Lactose	X	X									
Sucrose	X	X									X
Galactose				X							X
Fructose				X							
Xylose	X										
Starch	X										X
Pyruvate		X				X				X	
Formate						X					
Lactate										X	
Tartrate										X	
Fumarate										X	
Succinate										X	
Oxalacetate										X	
Mannitol		X									X

(1) - To be studied under anaerobic conditions.

(2) - To be studied under aerobic conditions.

* - To be studied if the organism can be grown in suitable amounts.

The design distribution will be found in table XI.

Table XI

Fractional Factorial Design
(7 factors, no interaction or negligible interaction assumed)

Observation	Factors							Treatment Combination
	A	B	C	D	E	F	G	
1	+	-	-	+	+	-	+	adeg
2	-	+	-	+	-	+	+	bdfg
3	+	+	-	-	+	+	-	abef
4	-	-	+	-	+	+	+	cefg
5	+	-	+	+	-	+	-	acdf
6	-	+	+	+	+	-	-	bcde
7	+	+	+	-	-	-	+	abcg
8	-	-	-	-	-	-	-	(1)

Each group of eight studies will be applied to a single organism and substrate.

The factors will be selected according to the organisms being considered. A detailed outline of these factors appears in table XII.

Table XII
 Details for Fractional Factorial Design (3rd Quarter)

Organism	A Temperature °C	B pH	C Oxygen Tension	Factors			G Agitation
				D Substrate** Concentration	E Cell Count	F Buffer Concentration	
Pseudomonas sp (G4A)	(1)* 35	7.4	Aerobic	5%	10x10 ¹²	0.5M***	+
	(2) 25	6.2	Anaerobic	1%	10x10 ¹⁰	0.1M	-
E. coli	(1) 35	7.4	Aerobic	5%	10x10 ¹²	0.5M	+
	(2) 25	6.2	Anaerobic	1%	10x10 ¹⁰	0.1M	-
A.aerogenes	(1) 35	7.4	Aerobic	5%	10x10 ¹²	0.5M	+
	(2) 25	6.2	Anaerobic	1%	10x10 ¹⁰	0.1M	-
A.cloacae	(1) 35	7.4	Aerobic	5%	10x10 ¹²	0.5M	+
	(2) 25	6.2	Anaerobic	1%	10x10 ¹²	0.1M	-

(*) (1) - refers to higher level

(2) - refers to lower level

** Pseudomonas sp (G4A) - formate, glucose

E. coli - glucose, maltose

A.aerogenes - fructose, maltose

A.cloacae - arabinose, galactose

*** Sorenson Buffer (13)

Oxygen tension, as related to growth, was selected because (a) some organisms can be cultivated either aerobically or anaerobically, (b) different enzyme systems may be formed under either type of growth condition, and (c) in some cases, hydrogen evolution occurs with both types of growth.

Agitation is applied to industrial fermentations to speed up reactions and increase product output. It has been observed that H₂ production by Pseudomonas sp (Strain G4A) is accelerated by agitation. The pH of the reaction can determine the nature of the end-products. The pH levels to be studied will be in the range for optimum growth and for optimum hydrogen production. The temperature at which the enzyme reaction is carried determined the amount of end-product. With each 10⁰ rise in temperature, one normally expects about twice the enzyme activity. Two levels of temperature will be studied, one close to the growth optimum and one close to the optimum for enzyme activity. Two enzyme concentrations (cell counts) will be studied. One will be based on previous data in this study and the other will be at a higher level. The same rationale will be applied to the selection of substrate concentrations. Two buffer concentrations will be chosen at the pH levels of the study. The purpose will be to determine whether pH maintained at one level will support maximum hydrogen production.

The design scheme will be set up using the terms of reference used in Davies.¹² The letters, A, B, C, D, E, F, G, will refer to each of the seven factors being considered. The symbol (+) will refer to the high level; the symbol (-) will represent the low level. The treatment combinations will be represented by the lower-case equivalents of the factor represented. The absence of the lower-case letter indicates the presence of the lower level; the presence of the lower-case letter refers to the presence of the upper level of the factor.

Other factors which should be studied further are the rate of gas production and the efficiency of substrate utilization. The rate will be followed by plotting gas evolution and percentage of hydrogen against time in hours for selected high hydrogen-producing, organism-substrate complexes. The efficiency of substrate utilization will be studied by measuring the amount of glucose remaining after the enzyme reaction.

The efficiency will be reported as millimoles H_2 produced per given quantity of glucose. The volume of H_2 will be related to power output of a conventional fuel cell.

IDENTIFICATION OF KEY PERSONNEL

The following personnel performed the approximate number of man-hours of work shown during the second quarter of the project.

Robert T. Foley 40 hours

Project scientist with background in electrochemistry and surface chemistry.

B.S. (Chemistry) University of Massachusetts

M.S. (Physical Chemistry) Lafayette College
(Graduate Work) New York University

Ph.D. (Physical Chemistry) University of Texas

Robert J. Bowen 72 hours

Scientist with background in electrochemistry and analytical chemistry.

B.S. (Chemistry) George Washington University
(Graduate Work) George Washington University

Gordon C. Blanchard 147 hours

Senior microbiologist with background in heterotrophic and autotrophic metabolism.

B.A. (Zoology) University of Vermont

M.S. (Biochemistry) University of Vermont

Ph. D. (Microbiology) Syracuse University

Ruby L. Brown 186 hours

Scientist with background in biology and chemistry.

B.A. (Biology and Chemistry) Catawba College

M.S. (Bacteriology) North Carolina State College

Hannibal de Schmertzing

16 hours

Research scientist with background in analytical chemistry.

B.S. (Chemistry) Peter Pázmany University, Budapest, Hungary

M.S. (Analytical Chemistry) Peter Pázmany University Budapest, Hungary

Ph. D. (Analytical Chemistry) Peter Pázmany University, Budapest, Hungary

Julian Chaudet

Head, Physical Instrumentation Section, with background in analytical chemistry and physical instrumentation.

B.S. (Chemistry) University of Chicago

M.S. (Physical Chemistry) University of Kentucky

Kenneth Abel

18 hours

Scientist with background in analytical chemistry and specialty in gas chromatography.

B.S. (Chemistry) Utah State University

Technical, Microbiology 66 hours

Technician, Analytical Chemistry 197 hours

Technician, Physical Chemistry 422 hours

TOTAL 1199 hours

PSD Dist List A (Mandatory)
January 1963

DISTRIBUTION LIST
SECOND QUARTERLY REPORT
CONTRACT Nr. DA 36-039 SC-90878

Commanding Officer
U.S.A. Electronics Research and
Development Laboratory
Fort Monmouth, N.J.
ATTN: Logistics Division
(MARKED FOR PROJECT
ENGINEER) (13)
ATTN: SELRA/P (1)
ATTN: Dir of Research/Engineering (1)
ATTN: File Unit #1 (1)
ATTN: Technical Document Center
ATTN: Technical Information Div.
(UNCLASSIFIED REPORTS ONLY
FOR RETRANSMITTAL TO
ACCREDITED BRITISH AND
CANADIAN GOVERNMENT
REPRESENTATIVES) (3)
ATTN: Security Division
(CLASSIFIED REPORTS ONLY
FOR RETRANSMITTAL TO
ACCREDITED BRITISH AND
CANADIAN GOVERNMENT
REPRESENTATIVES) (3)

OASD (R&D), Rm 3E1065
ATTN: Technical Library
The Pentagon
Washington 25, D.C. (1)

Chief of Research and Development
OCS, Department of the Army
Washington 25, D.C. (1)

Commanding General
U.S.A. Electronics Command
ATTN: AMSEL-AD
Fort Monmouth, N.J. (3)

Director
U.S. Naval Research Laboratory
ATTN: Code 2027
Washington 25, D.C. (1)

PSD Dist List A (Mandatory)
January 1963

DISTRIBUTION LIST
SECOND QUARTERLY REPORT
CONTRACT Nr. DA 36-039 SC-90878

Commanding Officer and Director
U.S. Naval Electronics Laboratory
San Diego 52, California (1)

Air Force Cambridge Research
Laboratories
ATTN: CRZC
L. G. Hanscom Field
Bedford, Massachusetts (1)

Rome Air Development Center
ATTN: RAALD
Griffiss Air Force Base, N.Y. (1)

Commanding General
U.S.A. Electronics Research and
Development Activity
ATTN: Technical Library
Fort Huachuca, Arizona (1)

Commanding Officer
Harry Diamond Laboratories
ATTN: Library, Room 211, Bldg. 92
Connecticut Ave & Van Ness St., N.W.
Washington 25, D.C. (1)

Commanding Officer
U.S.A. Electronics Material Support
Agency
ATTN: SELMS-ADJ
Fort Monmouth, N.J. (1)

Deputy President
U.S.A. Security Agency Board
Arlington Hall Station
Arlington 12, Virginia (1)

Commander
Armed Services Technical Information
Agency
ATTN: TISIA
Arlington Hall Station
Arlington 12, Virginia (10)

PSD Dist List A (Mandatory)
January 1963

DISTRIBUTION LIST
SECOND QUARTERLY REPORT
CONTRACT Nr. DA 36-039 SC-90878

Chief
U.S.A. Security Agency
Arlington Hall Station
Arlington 12, Virginia (2)

Commander
Aeronautical Systems Division
ATTN: ASAPRL
Wright-Patterson Air Force Base
Ohio (1)

Air Force Cambridge Research
Laboratories
ATTN: GRXL-R
L. G. Hanscom Field
Bedford, Massachusetts (1)

Headquarters
U.S. Army Material Command
Research and Development Directorate
ATTN: AMCRD-DE-MO
Washington 25, D.C. (1)

Commanding General
U.S.A. Electronics Command
ATTN: AMSEL-RE-A
Fort Monmouth, N.J. (1)

Commanding General
U.S.A. Combat Developments Command
ATTN: CDCMR-E
Fort Belvoir, Virginia (1)

Commanding Officer
U.S.A. Communications and Electronics
Combat Development Agency
Fort Huachuca, Arizona (1)

Director
Fort Monmouth Office
U.S.A. Communications and Electronics
Combat Development Agency
Fort Monmouth, N.J. (1)

PSD Dist List A (Mandatory)
January 1963

DISTRIBUTION LIST
SECOND QUARTERLY REPORT
CONTRACT Nr. DA 36-039 SC-90878

Air Force Systems Command
Scientific/Technical Liaison Office
U.S. Naval Air Development Center
Johnsville, Pennsylvania (1)

Corps of Engineers Liaison Office
U.S.A. Electronics Research and
Development Laboratory
Fort Monmouth, N.J. (1)

AFSC Scientific/Technical Liaison
Office
U.S.A. Electronics Research and
Development Laboratory
Fort Monmouth, N.J. (1)

Power Information Center
Moore School Building
200 South Thirty-Third Street
Philadelphia 4, Pennsylvania (1)

Marine Corps Liaison Office
U.S.A. Electronics Research and
Development Laboratory
Fort Monmouth, N.J. (1)

PSD Dist List "B" (Steering Group
Members - Mandatory)
January 1963

DISTRIBUTION LIST
SECOND QUARTERLY REPORT
CONTRACT Nr. DA 36-039 SC-90878

Dr. Sidney J. Magram
Physical Sciences Division
Army Research Office
3045 Columbia Pike
Arlington, Va. (1)

Dr. Ralph Roberts
Head, Power Branch
Office of Naval Research (Code 429)
Department of the Navy
Washington 25, D.C. (1)

Mr. Bernard B. Rosenbaum
Bureau of Ships (Code 340)
Department of the Navy
Washington 25, D.C. (1)

Mr. George W. Sherman
Aeronautical Systems Divisions
ATTN: ASRMFP
Wright-Patterson Air Force Base
Ohio (1)

Dr. John H. Huth
Advanced Research Projects Agency
The Pentagon, Room 3E157
Washington 25, D.C. (1)

Lt. Col. George H. Ogburn, Jr.
Auxiliary Power Branch (SNAP)
Division of Reactor Development
U.S. Atomic Energy Commission
Washington 25, D.C. (1)

Mr. Walter C. Scott
National Aeronautics & Space
Administration
1520 H Street, N.W.
Washington 25, D.C. (1)

PSD Dist List "B" (Steering Group
Members - Mandatory)
January 1963

DISTRIBUTION LIST
SECOND QUARTERLY REPORT
CONTRACT Nr. DA 36-039 SC-90878

Institute for Defense Analysis
1666 Connecticut Avenue, N.W.
Washington 25, D.C.
ATTN: Dr. George Szego
ATTN: Mr. Robert Hamilton (1)

U.S. Army Research and Development
Liaison Group (9851 Div.)
APO 757, New York, New York
ATTN: Dr. R. B. Stein (1)

Director
U.S. Army Research and Development
Laboratory
Fort Belvoir, Virginia
ATTN: Mr. D. Looft (1)

Chief of Ordnance
Department of the Army
Washington 25, D.C.
ATTN: Mr. J. Crellin (ORDTE) (1)

Englehard Industries
Military Service Department
113 Aster Street
Newark 2, New Jersey
ATTN: Mr. V. A. Forlenza (1)

Union Carbide Corporation
Union Carbide Consumer Products Co.
270 Park Avenue
New York 17, New York
ATTN: Mr. R. B. Klopfenstein (1)

United Aircraft Corporation
Pratt & Whitney Aircraft Division
East Hartford 8, Connecticut
ATTN: Mr. J. M. Lee (1)

PSD Dist List "B" (Steering Group
Members - Mandatory)
January 1963

DISTRIBUTION LIST
SECOND QUARTERLY REPORT
CONTRACT Nr. DA 36-039 SC-90878

Magna Corporation
Research and Development Laboratories
1001 South East Street
Anaheim, California
ATTN: Dr. Silverman (1)

General Electric Company
Research Laboratory
Schenectady, New York
ATTN: Dr. H. Liebhoafsky (1)

University of Pennsylvania
John Harrison Laboratory of Chemistry
Philadelphia 4, Pennsylvania
ATTN: Dr. J. Bockris (1)

Speer Carbon Company
Research Laboratory
Packard Road @ 47th Street
Niagara Falls, New York
ATTN: Dr. W. E. Parker (1)

Dr. H. D. Gregor
150 Lakeview Avenue
Leonia, New Jersey (1)

<p>AD Melpar, Inc., 3000 Arlington Blvd., Falls Church, Virginia.</p> <p>BIOCHEMICAL FUEL CELL, by R. T. Foley, G. C. Blanchard, and P. S. May.</p> <p>Second Quarterly Report, 1 October 1962 to 31 December 1962. 47 pp. incl. illus. tables.</p> <p>(Contract No. DA 36-039-SC-90878) Unclassified report</p> <p>Experimental investigation of microorganisms capable of producing hydrogen for fuel cell use is described.</p> <p>Analytical procedures, based on gas chromatography, were developed and refined to the point that a reliable technique for determination of H_2, O_2, N_2, and CO_2 in microquantities is now in operation.</p> <p>Microorganisms were investigated utilizing various substrates.</p>	<p style="text-align: center;">UNCLASSIFIED</p> <ol style="list-style-type: none"> I. Microorganisms - Experimental investigation 2. Substrates - Use for investigation 3. Gas chromatography - Analytical procedures <p>I. Foley, R. T. Blanchard, G. C. May, P. S. U. S. Army Electronics Research and Development Laboratory Contract DA 36-039 SC-90878</p> <p style="text-align: center;">UNCLASSIFIED</p>	<p style="text-align: center;">Accession No.</p> <p>AD Melpar, Inc., 3000 Arlington Blvd., Falls Church, Virginia</p> <p>BIOCHEMICAL FUEL CELL, by R. T. Foley, G. C. Blanchard, and P. S. May.</p> <p>Second Quarterly Report, 1 October 1962 to 31 December 1962. 47 pp. incl. illus. tables.</p> <p>(Contract No. DA 36-039-SC-90878) Unclassified report</p> <p>Experimental investigation of microorganisms capable of producing hydrogen for fuel cell use is described.</p> <p>Analytical procedures, based on gas chromatography, were developed and refined to the point that a reliable technique for determination of H_2, O_2, N_2, and CO_2 in microquantities is now in operation.</p> <p>Microorganisms were investigated utilizing various substrates.</p>	<p style="text-align: center;">UNCLASSIFIED</p> <ol style="list-style-type: none"> 1. Microorganisms - Experimental investigation 2. Substrates - Use for investigation 3. Gas chromatography - Analytical procedures <p>I. Foley, R. T. Blanchard, G. C. May, P. S. U. S. Army Electronics Research and Development Laboratory Contract DA 36-039 SC-90878</p> <p style="text-align: center;">UNCLASSIFIED</p>
<p>AD Melpar, Inc., 3000 Arlington Blvd., Falls Church, Virginia.</p> <p>BIOCHEMICAL FUEL CELL, by R. T. Foley, G. C. Blanchard, and P. S. May.</p> <p>Second Quarterly Report, 1 October 1962 to 31 December 1962. 47 pp. incl. illus. tables.</p> <p>(Contract No. DA 36-039-SC-90878) Unclassified report</p> <p>Experimental investigation of microorganisms capable of producing hydrogen for fuel cell use is described.</p> <p>Analytical procedures, based on gas chromatography, were developed and refined to the point that a reliable technique for determination of H_2, O_2, N_2, and CO_2 in microquantities is now in operation.</p> <p>Microorganisms were investigated utilizing various substrates.</p>	<p style="text-align: center;">UNCLASSIFIED</p> <ol style="list-style-type: none"> 1. Microorganisms - Experimental investigation 2. Substrates - Use for investigation 3. Gas chromatography - Analytical procedures <p>I. Foley, R. T. Blanchard, G. C. May, P. S. U. S. Army Electronics Research and Development Laboratory Contract DA 36-039 SC-90878</p> <p style="text-align: center;">UNCLASSIFIED</p>	<p style="text-align: center;">Accession No.</p> <p>AD Melpar, Inc., 3000 Arlington Blvd., Falls Church, Virginia</p> <p>BIOCHEMICAL FUEL CELL, by R. T. Foley, G. C. Blanchard, and P. S. May.</p> <p>Second Quarterly Report, 1 October 1962 to 31 December 1962. 47 pp. incl. illus. tables.</p> <p>(Contract No. DA 36-039-SC-90878) Unclassified report</p> <p>Experimental investigation of microorganisms capable of producing hydrogen for fuel cell use is described.</p> <p>Analytical procedures, based on gas chromatography, were developed and refined to the point that a reliable technique for determination of H_2, O_2, N_2, and CO_2 in microquantities is now in operation.</p> <p>Microorganisms were investigated utilizing various substrates.</p>	<p style="text-align: center;">UNCLASSIFIED</p> <ol style="list-style-type: none"> 1. Microorganisms - Experimental investigation 2. Substrates - Use for investigation 3. Gas chromatography - Analytical procedures <p>I. Foley, R. T. Blanchard, G. C. May, P. S. U. S. Army Electronics Research and Development Laboratory Contract DA 36-039 SC-90878</p> <p style="text-align: center;">UNCLASSIFIED</p>