

UNCLASSIFIED

AD

405 159

DEFENSE DOCUMENTATION CENTER

FOR

SCIENTIFIC AND TECHNICAL INFORMATION

CAMERON STATION, ALEXANDRIA, VIRGINIA



UNCLASSIFIED

NOTICE: When government or other drawings, specifications or other data are used for any purpose other than in connection with a definitely related government procurement operation, the U. S. Government thereby incurs no responsibility, nor any obligation whatsoever; and the fact that the Government may have formulated, furnished, or in any way supplied the said drawings, specifications, or other data is not to be regarded by implication or otherwise as in any manner licensing the holder or any other person or corporation, or conveying any rights or permission to manufacture, use or sell any patented invention that may in any way be related thereto.

405 159

63-3-5

SWC
TDR
63-28

405159 AFSWC-TDR-63-28

405159

INVESTIGATION, CONCEPTUAL DESIGN AND OPERATIONAL USE OF A DIRECTIONAL NUCLEAR RADIATION DETECTOR

Final Report
April 1963

405159

TECHNICAL DOCUMENTARY REPORT NUMBER AFSWC-TDR-63-28

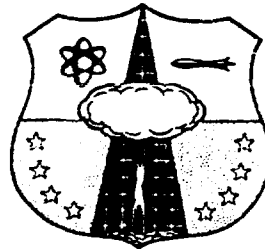

Development Directorate
AIR FORCE SPECIAL WEAPONS CENTER
Air Force Systems Command
Kirtland Air Force Base
New Mexico

Project No. 8171, Task No. 817102

(Prepared under Contract AF 29(601)-5405
by Franklin Systems, Inc., 2734 Hillsboro
Road, West Palm Beach, Florida)

**HEADQUARTERS
AIR FORCE SPECIAL WEAPONS CENTER
Air Force Systems Command
Kirtland Air Force Base
New Mexico**

When Government drawings, specifications, or other data are used for any purpose other than in connection with a definitely related Government procurement operation, the United States Government thereby incurs no responsibility nor any obligation whatsoever; and the fact that the Government may have formulated, furnished, or in any way supplied the said drawings, specifications, or other data, is not to be regarded by implication or otherwise as in any manner licensing the holder or any other person or corporation, or conveying any rights or permission to manufacture, use, or sell any patented invention that may in any way be related thereto.

This report is made available for study upon the understanding that the Government's proprietary interests in and relating thereto shall not be impaired. In case of apparent conflict between the Government's proprietary interests and those of others, notify the Staff Judge Advocate, Air Force Systems Command, Andrews AF Base, Washington 25, DC.

This report is published for the exchange and stimulation of ideas; it does not necessarily express the intent or policy of any higher headquarters.

Qualified requesters may obtain copies of this report from ASTIA. Orders will be expedited if placed through the librarian or other staff member designated to request and receive documents from ASTIA.

ABSTRACT

Several ground-based systems have been shown to be feasible for defining the location, curie strength and energy level of numerous and powerful radioactive, gamma-emitting sources scattered across an area of 1,000 ft. radius.

These systems involve use of fixed survey sites, or mobile sites, or a combination thereof. The preferred system would use two fixed and one mobile sites. (Mobile sites are desirable but unessential.)

Primary study considerations have involved accuracy of source location, radiation hazards to crew personnel, optimum means of source collimation, flexibility to adapt to various problem situations, and adaptability to use of certain 2nd - 3rd generation aids involving airborne facilities and super-imposed visual displays. All are important, and are discussed.

Radioactive background, detector shielding, and some equipment design factors are reported upon.

Opportunities and advantages for closely relating survey and decontamination operations are explained, and such a composite endeavor is recommended.

PUBLICATION REVIEW

This report has been reviewed and is approved.

M. E. SORTE
Colonel USAF
Director, Development Directorate



JOHN J. DISHUCK
Colonel USAF
DCS/Plans & Operations

TABLE OF CONTENTS

	Page No.
<u>ABSTRACT</u>	
I. <u>INTRODUCTION</u>	1
II. <u>SUMMARY OF CONCLUSIONS AND RECOMMENDATIONS</u>	1
III. <u>GAMMA SYSTEMS CONSIDERED</u>	5
A. <u>Single Survey Sites, Located Within, On Boundary of, and Outside the Area of Contamination</u>	5
B. <u>Multiple Ground-Based Stationary Survey Sites</u>	5
C. <u>Ground-Based "Stationary" Survey Sites with Limited Mobility</u>	6
D. <u>The Basic System Proposed</u>	7
1. Reasons for Preferring the System Proposed	7
2. Cost vs Weight vs Capability of the Proposed System (Trade-offs.)	7
3. Visual Adjuncts to the Proposed System	8
a. Visual Aids; Conventional	8
b. Gamma Pinhole Camera with Visual Readout	9
c. Airborne Support	10
4. Remote Control Possibilities	10
5. Computer Applications	11
a. Fixed Site Location	11
b. Confirmation That Three Fixed Survey Sites See Same Target	11
c. Radioactive Dosage Predictions	12
d. Optimum Path of Approach and Withdrawal Plus: Optimum Sequence of Removal of Sources	12
e. Optimum Counting Time	12
f. Identification of Half-Life	12
g. Calculation of Probable Fall-Out Patterns	12
h. Corrections for Calibration Differences Among Detectors	12
i. Coping With Survey Map Distortions	13
6. Initial Demarcation of Boundary of the Contaminated Area	13
7. Cooperative Methods of Survey-Decontamination	13
8. Means of Coping with Unfavorable Climatic and Other Conditions	14

	Page No.
IV. <u>OPERATING PROCEDURES TO BE USED WITH THE PROPOSED SURVEY SYSTEM</u>	14
A. <u>Three Fixed Sites</u>	14
B. <u>Two Fixed Sites Plus One Mobile Site</u>	15
C. <u>Fixed and Mobile Sites, with Auxilliary Visual and Computing Aids</u>	16
V. <u>THE TECHNICAL BACKGROUND OF THE TRANSMISSION AND ABSORPTION OF GAMMA RADIATION</u>	16
A. <u>Definition of Terms</u>	16
B. <u>Concepts of Gamma Transmission as Related to Fundamental Processes</u>	18
C. <u>Flux vs Curie Strength, Mev, and Distance</u>	18
D. <u>Field Strength vs Curie Strength, Mev, Distance, Etc.</u>	19
E. <u>Dosimetry Problems as Related to Field Strength</u>	20
F. <u>Basis for Shielding Calculations</u>	20
G. <u>Concept of Scintillator Capture Efficiency</u>	20
VI. <u>RADIOACTIVE BACKGROUND</u>	20
A. <u>Sky Shine and Airborne Dust</u>	21
B. <u>Ground Level Radioactive Dust</u>	21
C. <u>Contaminating Material of Short Half-Life</u>	21
D. <u>Sources in Close Proximity to Each Other</u>	21
E. <u>Methods of Coping Mathematically with Ground Level Background Sources</u>	21
F. <u>Counting Statistics</u>	22
VII. <u>EQUIPMENT CONSIDERATIONS</u>	23
A. <u>Scintillators</u>	23
1. Choice of Type	23
2. Choice of Size	23
B. <u>Scintillator Shielding</u>	23
1. Extent and Location of Shielding	23
2. Type and Weight of Shielding	24
C. <u>Scintillator Collimation</u>	25
1. Choice of Collimating Metal	25
2. Angular Resolution Considerations	25
3. Choice of Adjustable Collimation (Use of Light Pipes)	26

	Page No.
D. <u>Choice of the Photomultiplier Tube</u>	26
E. <u>Associated Power Supply - Preamplifier - Amplifier - Discriminator Circuitry</u>	27
F. <u>Read-out Devices</u>	27
1. Gamma Readouts	27
2. Visual Readouts	27
G. <u>Physical Support (Mounting Means) for the Survey Equipment</u>	28
H. <u>Equipment Calibration</u>	28
I. <u>Availability of Survey Equipment, Especially Optical (Visual) Adjuncts</u>	28
VIII. <u>APPENDIX</u>	28
A. <u>Tabulated Summary of Basic Survey System - Cost - Weight - Capability, Plus Several Enlargements Upon Basic System</u>	28
B. <u>Dosimetry Considerations</u>	29
C. <u>Concept of Scintillator Capture Efficiency</u>	31
D. <u>Calculations Pertinent to Background Radiation</u>	33
E. <u>Theory of Collimation</u>	34
REFERENCES	62
DISTRIBUTION	63

TABLE OF ILLUSTRATIONS

A. Figures

- Figure I A Strong Source at a Distance Can Appear To Be The Equivalent of a Weaker Source at a Closer Distance
- Figure II Basic Procedure
- Figure III Another Alternative Procedure (Aerial Aid to Mobile Unit)
- Figure IV An Alternative Procedure (Remote Control From Operating Center)
- Figure V Block Circuitry Diagram
- Figure VI Collimator Design
- Figure VII Multiple Collimation (Top View)
- Figure VIII Multiple Collimation
- Figure IX Continously Adjustable Collimation & Sensitivity with Varying Source - Detector Distance

B. Graphs

- Graph I Tri-Polar Coordinate Graph Paper
- Graph II Flux to Scintillator Surface vs Distance from Source
- Graph III Relative Field Strength at 1 Meter vs Photon Energy Level
- Graph IV Linear Absorption Coefficient vs Mev for Ur, W and Pb
- Graph V Effective Thickness of Ur Shield vs Mev
- Graph VI Roentgens/hr vs Shield (cm) Thickness
- Graph VII Shield Material Necessary to Reduce Gamma Field Strength
- Graph VIII Background Counts As A Function of Sample Percent Error
- Graph IX Gamma Flux vs Energy at Constant Field Strength
- Graph X Typical Angle Resolution Curve

Graph XI Crystal Capture Efficiency

Graph XII Angular Resolution and Fixed Site Location

I. INTRODUCTION

A. This is a final report of contract work that was authorized to start on July 1, 1962, and which, with approved extension, calls for a final report to be submitted on April 7, 1963.

The salient contract objectives require restatement in this report, and are as follows:

1. A suitable, practicable gamma detection survey system is desired, to contribute to the overall goal of decontamination of a given area.
2. This area may be approximated roughly by a circle of 1000 feet radius.
3. Energy strength (energy level) of the gamma sources involved shall be assumed to be in the range of 0.5 - 10.0 Mev (measurable to $\pm 10\%$).
4. Any one gamma target source shall have a field strength (at one meter) which lies within the range of 0.5 - 2000 R/hr.
5. Background radiation may be expected to raise the total field strength at any one observation point to as much as 5000 R/hr.
6. Numerous target sources must be considered.
7. It is desirable that the gamma detector be portable, and capable of being carried by two men.
8. The detector should have a flux readout dial with $\pm 5\%$ full scale resolution, or better.
9. Angular resolution should be limited to ± 20 minutes of arc, or less.
10. Ground level survey operations are preferred, with no need to enter the contaminated area.

B. In a meeting held at Kirtland Air Force Base on November 6, 1962, at which time the technical objectives of the contract were reviewed in the light of already completed research, it was agreed that certain of the contract's specifications should be given a more liberal interpretation. For example,

1. Airborne aids to the basic ground survey may be considered, but not depended upon entirely.
2. Not all ground-based sites need be fixed position sites. (That is, a mobile site or vehicle may be considered.)
3. The ± 20 minutes of arc specification on angular resolution may be interpreted as the equivalent of source location within ± 5 feet.
4. Optical aids to gamma sensing devices may be considered.

II. SUMMARY OF CONCLUSIONS AND RECOMMENDATIONS

A. There are several feasible gamma detection systems that not only will meet the operational objectives of the contract but will, in addition,

facilitate the solution of the basic problem which is DECONTAMINATION.

1. The general objective is decontamination.
2. The specific contract objective is to provide survey means that will be helpful in guiding decontamination work.
3. The equipment considerations relate to the particular survey system to be used.

B. No one survey-decontamination system, without considerable flexibility, will be optimum in all situations. A simple basic system, with provisions for use of optional equipment, is highly desirable. Such a flexible system is proposed in this report.

C. The proposed survey-decontamination system not only meets the contract's survey requirements but in addition can be useful in:

1. Effecting the initial determination of the boundary of the contaminated area.
2. Assisting decontamination efforts in a cooperative operation involving both the survey and decontamination functions.

D. Usually, but not necessarily, a cooperative survey-decontamination activity is desirable in achieving the primary objective -- decontamination -- in the most efficient manner.

E. The basic survey-decontamination system should include two fixed position sites and one mobile site. In situations permitting a survey completion prior to initiation of decontamination efforts, due to lack of urgency associated with the latter, three fixed sites with no mobile site can accomplish the objective.

F. Although choices may be made regarding the relative angle and distance resolution* of fixed vs mobile sites, it is proposed that the fixed sites be

*"Resolution" generally is used as a term to measure the accuracy with which a target source can be located in an angular direction, although accuracy in a radial direction is involved also. Any gamma detector with collimation will have a certain degree of directivity or collimation or resolution, as does an optical telescope, and this (See Section VII-C) is a function of numerous variables. In general, however, the smaller the source-detector displacement, the less the resolution that is required. Position location in the proposed system depends upon angular resolution, primarily. As general "rules of thumb:"

1. high resolution refers to the detector's ability to locate a target source within \pm 5 feet.
2. medium resolution extends this range to \pm 10 - 20 feet.
3. low resolution is concerned with \pm 20 - 50 ft. or possibly even greater. Low resolution equipment, operating close-in, can accomplish as much as high resolution equipment operating from a distance.

equipped (collimated) for medium to high resolution, whereas the mobile site should have adjustable resolution from low to high. Means for accomplishing this adjustable resolution are discussed in this report.

G. It is proposed that the fixed site data be used to guide the mobile site (vehicle) to within 10 - 25 feet of a target source, although capable of greater accuracy if needed, and that the vehicle's gamma detection facilities be used to direct it to exact target location. Its high resolution may be needed to differentiate between two targets that lie close together. Its low resolution but larger scintillator assists in the early stages of target approach, confirming fixed site information, and can be used as a time-saving aid in the close-in approach if the target source is not of too high a curie strength.

H. It is not deemed necessary that ± 20 minutes angular resolution be used in source location with the proposed system. Although this can be accomplished, the final actions of the mobile site can locate a target source within a very few feet without requiring this degree of collimation or angular resolution. (As stated above, high resolution is proposed primarily to differentiate between very closely spaced target sources.)

The design of a ± 20 minute angular resolution head for survey purposes is feasible. The use of this survey head at highest resolution in the proposed survey-decontamination system is not essential to the success of the operating system.

The operating survey system requires no more than ± 40 minutes for fixed site locations from three corners of a square, the sides of which are tangent to the boundary of the 1000 foot radius contaminated circle. However, use of the ± 20 minute heads at their maximum resolution level provides information more rapidly in certain situations.

I. It is recommended that in any situation requiring quickest possible completion of decontamination, system equipment should include provisions for superposition of three area scans, as follows:

1. An aerial photograph or TV scan of the contaminated area.
2. An area plot of the locations of the major radioactive sources that require prompt removal.
3. TV or other means of showing at any time the location of the mobile site in reference to terrain and target locations.

This method of data presentation can be very effective in aiding decontamination operations.

J. A helicopter, if available, can be very helpful in aiding the prompt approach of survey and/or decontamination vehicles to a target location.

This is especially true if terrain and other conditions require that the vehicle(s) make a circuitous approach to the target. The system proposed does not require a helicopter, but could benefit from its availability and use.

K. On-site analog computer facilities offer many opportunities to reduce survey and decontamination time, and to minimize the risk of excessive radiation exposure for crew personnel.

L. Using three fixed sites for survey purposes, the survey can be conducted without undue radiation hazard for survey personnel. However, if the proposed two fixed sites plus one mobile site are used to accelerate the survey, in certain situations it will be desirable to remote-control the mobile site.

M. Remote control of all sites is an interesting possibility, and is available within the framework of the proposed system. (This option should be utilized in the event that major target sources are closely positioned and are of quite high curie strength.)

N. Equipment must be considered in this type of feasibility study because the success of any proposed system irrefutably is related to its hardware capabilities and limitations. Some details of equipment considerations are included in this report to establish feasibility. The required equipment can be provided to make the system operational, and to meet (and more than meet) the contracts' objectives.

O. The merits of the proposed system are subject to verification, either by model studies or by larger scale test site studies. Feasibility having been assured, such studies should be made to facilitate the detailed design of optimum equipment components.

P. To put an operational system into the field for test purposes, most of the work remaining involves merely engineering design and assembly; particularly --

1. continuously adjustable collimation devices, and
2. details of equipment for superimposing various types of scans, as mentioned in (I) above.

Most of the hardware items needed to accomplish this objective are available, and can be assembled in a mock-up of the proposed field system.

Q. There is no technical specification in the contract that appears to be beyond reach in the immediate future. The problem now appears to be a developmental rather than a research challenge.

R. A chart of the recommended system, plus illustrative drawings, is presented in Appendix material, VIII-A.

S. The opportunities inherent in the use of multiple collimation of a large size scintillator, or the equivalent use of several adjacent scintillators, each separately collimated, have not been exploited to the extent possible and perhaps desirable. They offer promise of compactness and weight reduction in the gamma detector. Moreover, this is another approach to the challenge of adjustable collimation, while maintaining adequate angular resolution. An additional bonus is that the (overall) larger scintillator offers more "cushion" in its capabilities.

III. GAMMA SYSTEMS CONSIDERED

A. Single Survey Sites, Located Within, On Boundary Of, and Outside The Area of Contamination

Single survey sites were considered quite early in the research work on this contract, and quickly were ruled out. Source confusion is the primary problem, because no one fixed position ground survey site can distinguish between two in-line sources that have an equal ratio of curie strength to spatial separation. That is, a distant source of high curie strength can appear to be the equivalent of a near source of lower curie strength.

Late in the course of the study, consideration was given to a single mobile site, remotely controlled, and operating near the center of the contaminated circle. Although referred to as a single site, it actually is a dual site inasmuch as the mobile unit would carry two toe-in gamma receptors at opposite ends of a yardarm. It is proposed that the degree of toe-in be adjustable, thereby permitting source distance determinations through time measurements for beam maxima at a constant angular sweeping rate. Potential accuracy of this approach looks promising but has not been investigated fully.

B. Multiple Ground-Based Stationary Survey Sites

If two widely separated survey sites are used, there still remains the possibility of source confusion. However, it is less than that associated with use of a single site. If three fixed survey sites are used, suitably positioned in reference to each other, source confusion still can exist but has been reduced to a very low order of probability. (Figure I)

Such considerations led to the concept of positioning the three sites on corners of a square containing within it the contaminated area. Sides of the square may be tangent to the contaminated circle but need not be so. Corners of an equilateral triangle also may be used, but offer no advantage over the "three corners of a square -- TCOS" procedure.

Using highly collimated gamma detection equipment, TCOS can deliver the required accuracy in defining source positions. Its major advantage

is that it is a relatively simple system, and can be conducted with one detector unit positioned sequentially at each of the three corners of the square. In terms of equipment costs and demands on number of survey crew personnel, plus their safety, it is optimum or nearly so. Its disadvantages are that:

1. It does not offer a rapid means of survey.
2. It is a procedure to be used optimally prior to initiation of decontamination work.
3. It requires considerable time to locate the positions (relative to each other) of the survey site locations.

A unique tri-polar coordinate graph paper (Graph I) was developed to facilitate the use of the TCOS procedure. It permits the plotting of data from the three survey sites in a manner that quickly will enable survey personnel to assure themselves that there is no source confusion in their determination of source position and curie strength. In this type of graph angular locations are of obvious meaning, and constant distance contours may be related to any one of several variables. The preferred one is count rate, in a properly calibrated system. That is, if there were only one source, it would induce the same maximum count rate regardless of its position on a circular arc of constant maximum count rate parameter. This concept is not in conflict with the well known and strong angular dependence of count rate, when using a collimated receptor.

Angular bearings plus count rate data from each of the three survey sites are used to locate major sources and assess their curie strength. This operation is done with "window" detectors offering selective gamma energy discrimination at various energy level ranges throughout the specified 0.5 - 10 Mev energy level range. The tri-polar coordinate graph paper may be calibrated for various Mev increments, and the survey crew(s) would be equipped with a tablet of such graph paper, with all sheets necessary to cover the entire Mev range.

In summary, the TCOS system can be very effective in situations wherein survey speed is not a controlling factor, and where facilities (system adjuncts) for a more rapid survey are not available.

C. Ground-Based "Stationary" Survey Sites with Limited Mobility

It is feasible for any one or more stationary sites to collect supporting sets of data by moving step-wise in either a radial or angular direction in reference to the approximate center of the contaminated circle. In principle, such movements of site location can substitute for other truly fixed site locations. Actually, however, the extent of movement required to be really effective in contributing to accuracy of source location and in circumventing source confusion is such that there is no advantage (and

possibly disadvantages) in reference to the TCOS system. For this reason these possibilities were shelved after an initial consideration of them.

D. The Basic System Proposed

The preferred system involves use of two fixed survey sites plus one mobile vehicle site. The vehicle may be one designed specifically for survey duty or, conversely, it may be a decontamination vehicle that is adapted to carry this system's equipment.

1. Reasons for Preferring the System Proposed.

The addition of a mobile site adds a new dimension to the accomplishment potential of the system. Operational flexibility is increased markedly, survey speed is accelerated appreciably, equipment requirements (aside from the vehicle) are simplified to a certain extent, and, as discussed in subsequent paragraphs, the intimate cooperation that it permits between survey and decontamination efforts enables the latter to be initiated at an earlier time period.

These advantages derive primarily from the fact that mobility permits:

- a. Use of heavier equipment than would be deemed suitable for fixed sites capable of being carried by two men.
- b. Invasion of the contaminated area with sufficient shielding and dosimetry detectors to protect personnel, or by remote-control operation.
- c. The speed advantage inherent in making some measurements at a considerable distance and others quite close to the target source. (Figures II, III, IV, V)

2. Cost vs Weight vs Capability of the Proposed System. (Trade-Offs.)

This is an area in which "trade-offs" are an important consideration. The primary factors to be considered in evaluating trade-off opportunities are:

- a. Speed of completion of survey and decontamination efforts.
- b. Minimum radiation hazards for personnel involved in these operations.

Details of trade-offs in system procedure and in hardware construction are believed to be subsidiary to these two primary factors, as are also cost and weight of system equipment.

The absolute and relative importance of the two primary factors will be contingent, of course, upon the particular emergency encountered. That is, in some situations the need for speed in survey and decontamination will not be urgent, and great precautions can be taken in protecting

crew personnel. Conversely, in other situations which demand promptest possible action, adjuncts to the basic system facility will be of great advantage. Inasmuch as it may not be possible to pre-guess all situations that can be encountered, a versatile system that provides for use of air transported auxiliaries when needed appears to be most desirable.

In Section VIII-A there is a listing of expected weight-cost-capability characteristics of several variations of the proposed system. (This table will be more intelligible after consideration of additional information to be presented in this section of the report.)

3. Visual Adjuncts to the Proposed System.

The basic system, operated with or without the preferred mobile site, can benefit appreciably from the availability and use of various kinds of auxiliary equipment. Those suggested for consideration are the following:

a. Visual Aids; Conventional

The visual aids that are desirable include:

1. A small telescope or binoculars to be mounted on the collimated gamma detectors.
2. A powerful light on the mobile site to aid survey operations at night.
3. Aerial Photographs and/or TV observation of the contaminated and the surrounding terrain.
4. TV observation of the mobile site's position.
5. Optical path markers, useful for day or night operations, air-dropped to facilitate the progress of the mobile site when moving into a primary target source.

All of these are standard equipment items that are available for purchase.

If the target source is not too distant from the survey site attempting to locate it, use of the small telescope which accurately is lined up with the gamma collimator can, at times, be helpful in confirming the location of a target of sufficient physical size. This is a time-saving aid because in such a case a single site can locate a major target source without source confusion. It is useful only during daylight hours, of course. However, in cooperating with the mobile site in night survey operations, the fixed site can follow the vehicle's progress by observing the brilliant light that it carries.

Aerial photographs and/or TV offer exceptionally interesting possibilities. They permit a superpositioning of:

1. A terrain map.
2. A map of target source locations as determined by gamma detection means.
3. The position of the mobile site in reference to the target sources.

Such a visual display would be of great help to decontamination personnel. The practicability of TV assumes, of course, that an elevated site (e.g., rooftop, hilltop, helicopter, etc.) is available for its location.

b. Gamma Pinhole Camera with Visual Readout

Such cameras have been made (1) (2) and used to advantage with, e.g., a mosaic scintillator. The latter is a checkerboard array of 100 or more individual scintillator elements of small size, each with its own photomultiplier tube, and with a TV type of readout. (Or, by Camera Lucida techniques, the mosaic scintillation pattern may be photographed at time intervals.)

The camera views a wide angle field and requires no focusing. Its "pinhole" actually is a small hole in a quasi-cone shaped collimator of heavy metal. In principle, it provides a rapid means of viewing a wide area from an elevated position and making an approximate location of nuclide target sources within that large area. This, in turn, enables the more precise, highly collimated site detectors to achieve precision fixes more rapidly because they will have been informed regarding approximate target locations.

The gamma pinhole camera is a relatively undeveloped instrument. Presently it is limited in its effectiveness by "cross talk" between nearby mosaic scintillator elements (a consequence of gamma scattering) that in effect blurs the position of the target sources. However, further research in this area possibly could lead to a quite valuable survey aid. Although ideas for minimizing the objections to this camera are in hand, they are not yet sufficiently fully developed to justify a firm recommendation that this be made the subject of near-future research effort.

The gamma pinhole camera is not believed to be applicable in situations where there is rapid relative motion between the nuclide source and the detecting camera. However, considering the projected use of this detector, there will be no such relative motion

involved. It is for this reason, primarily, that this type of camera should be retained as a candidate for future research study in the general area of the contract's objectives.

c. Airborne Support

A helicopter, if available, can be a very effective supporting aid in making the survey and in concurrent decontamination efforts. It is capable of:

1. Aerial photography and airborne TV observation.
2. Guiding the mobile site across difficult terrain by either visual observation and radio communication or by dropping markers to provide it with a "road map" to follow.
3. Gamma pinhole camera observations, if that potential were fully developed.

A helicopter is preferred to a slow flying airplane because of its maneuverability and its versatility. However, some if not all of its proposed functions could be provided by a small aircraft.

4. Remote Control Possibilities.

The speed of survey and associated or subsequent decontamination work is contingent upon radiation hazards to personnel, among other things. Such hazards will depend, of course, upon the particular situations confronted. It is believed wise to design the proposed system to include provision for remote control of the mobile site and (possibly but not probably) a similar control of the two fixed sites.

The initial survey that defines the boundary of the contaminated area will be instrumental in determining the need for such remote control. That is, data from this initial survey can be expected to determine the radiation hazards for the personnel who must carry out any variation of the basic theme of the proposed system. Such remote control equipment can be air lifted to the danger zone when and if required.

Remote-controlled equipment may be self-powered by batteries or generators, or, as is more likely to be desired, powered by cables leading to a central power source.

Communications between remote-controlled sites and a central computation center requires cables or (better) radio control. A "two way street" is assumed in these communications; i. e., instructions are sent to the sites and useful data are returned.

Guidance of a remote-controlled mobile site may be accomplished either by ground-laid cables or by radio control. Equipment to effect this objective is available, and little if any research and development work is needed in this area.

If remotely controlled sites are used, it will be highly advantageous to establish a central communications center which controls operations and receives and digests all data. It can be positioned in a radiation-safe locale, and in many ways can facilitate the operations.

5. Computer Applications.

There are opportunities for effective use of large and presumably distant digital computers, as well as for much smaller, on-location analog or digital computers. These options are sufficiently interesting to deserve a semi-detailed discussion.

Two widely separated survey fixed sites, scanning the contaminated area, do not "see" the numerous target sources in the same sequence. This fact adds to the complexity of the problem of avoiding source confusion and arriving at final survey data in the shortest possible time. Toward this end, facilities for communicating with a distant computer site of high storage or memory capability will greatly reduce survey time.

Such computers not always are available, even in an emergency such as that anticipated by the technical objectives of this contract. For that reason, the availability of a much smaller electronic computer, on-location, is desirable. Its possible functions include the following:

a. Fixed Site Location

In using a survey procedure involving several fixed survey sites, such as "three corners of a square", an appreciable amount of pre-survey time may be required to locate the third corner with sufficient accuracy. With a computer, the third site need not be on the corner of a square to permit accuracy in radioactive source location. All that is required is that its position in reference to the other sites be known, and the computer can correct for the fact that its data are not taken at a corner of the square.

b. Confirmation That Three Fixed Survey Sites See Same Target.

Slide rule calculations, graphing or other means of assuring the three crews that they have sighted the same target can be supplanted by a computer calculation to provide this verification.

c. Radioactive Dosage Predictions.

Following completion of taking and mapping the survey data, the computer can calculate the total dosage to be expected in the time period assumed necessary to remove any given source according to any selected path of approach and withdrawal.

d. Optimum Path of Approach and Withdrawal

Plus:

Optimum Sequence of Removal of Sources.

These matters are subject to analog computer calculations, and relate to both dosage risks and time-saving in decontamination work. (Of especial importance when rough terrain prohibits a straight line approach to a radioactive source.)

e. Optimum Counting Time.

For any desired accuracy of source strength determination there is an optimum counting period that relates to background level. This optimum is not easily determined if the background is "lopsided," i. e., if it differs from the left to the right side of a primary target source due to secondary target source locations. (A highly collimated detector is assumed, of course.) A computer can be programmed to calculate optimum counting times.

f. Identification of Half-Life.

In a situation wherein days and not hours are required to complete a survey, or more particularly where surveys can be repeated, a computer can be programmed to analyze the data in a manner that will define which primary target sources are of high curie strength but short half-life. Such information is of obvious utility to the decontamination crew(s).

g. Calculation of Probable Fall-Out Patterns.

Using wind - weather information, the probable fall-out pattern of radioactive "dust" immediately following an accident involving radioactivity may be calculated.

h. Corrections for Calibration Differences Among Detectors.

When using multiple detector sites, and assuming that rapid surveying is essential, known calibration differences can be "allowed for" in less time than might be required to place all detectors in mutually consistent calibration.

i. Coping With Survey Map Distortions.

When using superimposed TV or similar optical scans with gamma scans, errors due to misregister or distortion can occur. Using data from gamma sources "planted" at known locations in or around the contaminated area, a computer can be programmed to make the necessary corrections.

The complexity of such a computer depends upon the number and types of functions that it is asked to perform. In view of current solid state circuitry opportunities, it can be a relatively small and light weight equipment, and of acceptable cost.

6. Initial Demarcation of Boundary of the Contaminated Area.

In using the proposed system, the initial boundary-defining survey would rely greatly on mobile site data. A circular sweep of the terrain by the vehicle, which constantly assures itself that all sources of major interest are on one side and none on the other side of the vehicle, provides the first approximation of the contaminated area. Successive circular sweeps of smaller radius, each testing field strength to determine if it is too high for safe operation of a fixed ground station site, in due time will define:

- a. The minimum safe circle diameter to be considered for subsequent and more accurate surveying, and
- b. The approximate locations of major sources that lie near the periphery of the finally established area of contamination. (Such locations will influence placement of the fixed sites, and are subject to confirmation of location and source strength by airborne equipment, if available.) In this type of operation the fixed sites function at a distance, only to confirm the approximate source locations noted by the mobile site. Later, the fixed sites will be repositioned in the interest of conducting a much more accurate survey.

In this second (accurate) survey step, the fixed sites are presumed to be located where they will have the least difficulty in establishing accurate positions location of the strongest target sources.

7. Cooperative Methods of Survey-Decontamination.

If only fixed survey sites are used, they can contribute most, probably, to a pre-decontamination completion of the survey. They will be highly accurate but relatively slow in performance, and their contribution largely will be that of influencing the choice of sources which decontamination personnel will be most interested in removing first.

Substitution of a mobile site for one of the three fixed sites adds a new dimension. It makes practicable a "cleanup as you go" operation in which survey and decontamination crews unite their efforts in a move that gradually shrinks the area of the contaminated circle.

The third possibility actually is a compromise of the first-mentioned two; viz., a reasonably thorough survey enables the decontamination crew to locate quickly and remove certain major sources, following which survey personnel suggest the next group of sources to be removed. This is a "bootstrap" operation calling for quite close cooperation between survey and decontamination personnel, but leads to removal of the most potent sources in the shortest possible period of time, and with minimum radiation risks. In most cases it is the procedure to be recommended. Always there will be exceptions, of course.

8. Means of Coping with Unfavorable Climatic and Other Conditions

Heavy rain, fog, and night vs daytime conditions are survey and decontamination factors to be considered. Optical (visual) aids are very helpful, as discussed in a preceding sub-section. Although a major advantage of gamma detection equipment is that it is not handicapped by visibility conditions, the utility of its supporting optical aids may be. However, zirconium arc lights of tremendous brilliance are available, and may be used to counter such unfavorable weather conditions. Thus, such problems are not believed to be fundamental. The fixed survey sites have weight and construction such that sub-hurricane or sub-tornado winds are not likely to topple the equipment.

Difficult terrain problems must also be considered; (e.g., hills, buildings and tree groves that intercept and attenuate the flux from a target source.) This situation depreciates the value of a completely fixed site survey, and adds to the importance of a mobile site and good (e.g., helicopter) means of directing its movements.

Terrain considerations are of considerable importance. They, perhaps more than any other factor, justify the need for gamma and/or visual observations from an elevated site.

In summary of this entire Section III, it may be stated that the key to feasibility is a "sound" basic system that has sufficient flexibility to permit use of numerous supporting aids when specific problem conditions require them.

IV. OPERATING PROCEDURES TO BE USED WITH THE PROPOSED SURVEY SYSTEM

A. Three Fixed Sites

In using the basic system, the procedure steps are as follows for three

fixed sites located at three corners of a square.

An Mev range is selected and two adjacent ones of the three sites begin a slow scan of the area, starting with their collimators viewing each other along the straight line connecting the two sites. If the sources are indeed numerous, the probability is that, if each site uses the scanning speed of the other, one will locate a major source before the other site does. That site obtains the most accurate direction bearing possible, and advises the second site of that direction. The second site continues to scan until it too locates a source of significant strength; meanwhile, the first site "rests."

Through use of the above-discussed tri-polar coordinate graph paper, and assuming that the two detection equipments have been calibrated previously against each other, the two sites crews may now establish whether they are sighting the same target. That is, each knows an angle and a count rate. If it appears that they indeed are sighting the same target, then the third fixed site is requested to sight at a specified angle and make a count rate determination. If it locates a source in the predicted direction and if its count rate is consistent with the graph calibrations, the probability is quite high that there is no source confusion. The source location is then plotted on the graph.

This operation is repeated until all significant sources in the chosen Mev band have been located, after which, with a newly selected Mev band width, all actions again are repeated. In addition to pre-survey calibration of equipment it is required that the proper graph labelling be used for the Mev band selected. Furthermore, it is necessary that the angle data be more precise than the count rate data because inconsistencies in the latter can result from intervening objects that attenuate the gamma flux more than air would do.

Through such repetitive operations there is derived a map of target source locations which can be adequately accurate in location and Mev determination, but which may suffer in accuracy of determination of curie strength. The overall time required is contingent upon the number of major sources requiring identification, and in some cases on the half-life of the sources. Weather and terrain conditions also are influencing factors.

B. Two Fixed Sites Plus One Mobile Site

For a time, the procedure here follows that of the TCOS operation. The principle difference is that the two fixed sites need not be so accurate in their target location determinations, and their information to the mobile site permits the latter to come sufficiently close to any primary target to

"nail down" its position quite precisely. The same system of graphing of source locations can be used. Inter-site communications, probably via radio, are needed in all cases.

C. Fixed and Mobile Sites, with Auxilliary Visual and Computing Aids

The principle is relatively unchanged but the mobile site now can receive instructions from a helicopter, for example, to augment the guidance it obtains from fixed site locations. A central communications center, especially in the event of remote-control facilities, provides for this in an efficient manner.

Equipment-wise, these three system options represent the low, medium and high ranges of the operational spectrum. Other system procedures may be fitted between any two of them.

V. THE TECHNICAL BACKGROUND OF THE TRANSMISSION AND ABSORPTION OF GAMMA RADIATION

This background is introduced for the purpose of making other sections of the report more readable and more readily understandable by those who do not have frequent need to use the concepts and the nomenclature included in this report. It is introduced prior to the section on Equipment Considerations to facilitate understanding of the comments made on the "hardware."

A. Definition of Terms

The physical quantities mentioned in this report which are of particular importance are defined herein, as quoted in most cases from the U.S. Government's Radiological Health Handbook.

1. Absorption Coefficient, Linear: A factor expressing the fraction of a beam of X- or gamma radiation absorbed in unit thickness of material. In the expression $I = I_0 e^{-\mu x}$, I_0 is the initial intensity, I the intensity of the beam after passage through a thickness of the material, x , and μ is the linear absorption coefficient.
2. Attenuation: The process by which a beam of radiation is reduced in intensity when passing through some material. It is the combination of absorption and scattering processes and leads to a decrease in flux density of the beam when projected through matter.
3. Attenuation Coefficient, Linear: The fractional number of photons removed from a beam of radiation per unit thickness of a material through which it is passing due to all absorption and scattering processes.
4. Collimator: A device for confining the elements of a beam within an assigned solid angle.

5. Count Rate: The number of counts/sec that the MPT and its associated circuitry are capable of tabulating. (That is, there is an upper limit to the resolving power of the circuitry.)

6. Field Strength, or Roentgens/hr: The roentgen is defined as an exposure dose of X- or gamma radiation such that the associated corpuscular emission per 0.001293 grams of air produces, in air, ions carrying 1 electrostatic unit of quantity of electricity of either sign. (Abbreviated: r.)

7. Flux: For electromagnetic radiation, the quantity of radiant energy flowing per unit time. For particles and photons, the number of particles or photons flowing per unit time. (Photons/cm² - sec.)

8. Radioactive Half-Life: Time required for a radioactive substance to lose 50% of its activity by decay. Each radionuclide has an unique half-life.

9. Reaction Energy, Nuclear: In the disintegration of a nuclear reaction, it is equal to the sum of the kinetic or radiant energies of the reactants minus the sum of the kinetic or radiant energies of the products. (If any product of a specified reaction is in an excited nuclear state, the energy of subsequently emitted gamma radiation is not included in the sum.) The ground-state nuclear reaction energy is the reaction energy when all reactant and product nuclei are in their ground states; symbol Q_0 .

Mev is the symbol for 1 million electron volts, or 10^6 ev. (written Mev.)

10. REM: The rem is the unit used to express human biological doses as a result of exposure to one or many types of ionizing radiation. The dose in rems is equal to the absorbed dose in rads times the RBE factor of the type of radiation being absorbed. Thus the rem is the unit of RBE dose.

11. Scintillator Capture Efficiency: The percentage of photons retained by the scintillator, and which result in scintillations within a prescribed wavelength band.

12. Scintillation Counter: The combination of phosphor, photomultiplier tube and associated circuits for counting light emissions produced in the phosphors.

13. Shielding: A body of material used to prevent or reduce the passage of particles or radiation. A shield may be designated according to what is intended to absorb, as a gamma-ray shield or neutron shield, or according to the kind of protection it is intended to give, as a background,

biological, or thermal shield. The shield of a nuclear reactor is a body of material surrounding the reactor to prevent the escape of neutrons and radiation into a protected area, which frequently is the entire space external to the reactor. It may be required for the safety of personnel or to reduce radiation sufficiently to allow use of counting instruments for research or for locating contamination or airborne radioactivity.

14. Curie: That quantity of a radioactive nuclide disintegrating at the rate of 3.700×10^{10} atoms per second. (Abbreviated: c). Several fractions of the curie are in common usage.

B. Concepts of Gamma Transmission as Related to Fundamental Processes

Gamma photons are subject to a trio of primary propagation reactions, in passing through gaseous, liquid or solid matter. These three determine for any given intervening material the Mev - dependence of the absorption and attenuation constants. The three (and second order buildup effects are not mentioned herein) include:

1. Photoelectric effect.
2. Compton scattering.
3. Pair production.

These three assume increased importance, in turn, as the photon energy level increases. It is for this reason that plotted curves of such constants show minima in the 0.5 - 10.0 Mev range specified by this contract.

Fundamentally, the photoelectric effect is most effective at the low energy range of the spectrum, and represents gamma photon absorption. The intermediate Compton scattering range offers the billiard ball concept of one gamma photon interacting to lose some of its energy or momentum, which in turn is delivered to another particle or photon. Pair production offers the "two for one" concept within the bounds of the laws of conservation of energy and momentum. This is a quite high Mev energy level possibility. These functions tend to differentiate gamma from light (visible) photons, and suggest why the two types must be considered somewhat differently.

All decay rates in gamma radiation, in air, in liquid, or in solids must be interpreted in terms of these three fundamental considerations. In summary, all of this means that air attenuation and shielding-collimation attenuation depends not only upon the material used but also upon Mev. ⁽³⁾

C. Flux vs Curie Strength, Mev, and Distance

Flux to the scintillator varies, -

1. linearly with curie strength
2. in a complicated manner with distance which involves an inverse square term for close distances but the product of such a term with an exponential term at considerable distances
3. in an exponential manner with the Mev-influenced attenuation or absorption quantity.

Hence, it is not a concept to be grasped at the first reading. Graphs are presented to illustrate the inter-relationship of these variables, (Graphs II, III, IV, V and IX). A complicating factor is that some radioactive nuclides eject two photons for each nuclear disintegration whereas others eject only one.

In its general form, the mathematical equation picturizing this situation (sans building) is:

$$F = \frac{(3.7) (10^{10}) (C) (n) e^{-\mu r}}{4\pi r^2} \quad (\text{c. g. s.})$$

where: r = source-detector separation
 C = curie strength
 n = photons/disintegration
 F = flux to scintillator
 μ = linear absorption or attenuation coeff. (cm^{-1})

This is a basic equation, often called upon for calculations.

$$\mu = f (\text{Mev}).$$

(See first paragraph following first equation in VIII-B)

D. Field Strength vs Curie Strength, Mev, Distance, Etc.

It is possible to relate flux and field strength (R/hr) by the following formula:

$$\frac{(3.7) (10)^{10} n C}{4\pi r^2} \cdot E \cdot \mu \cdot K = 1 \text{ R/hr}; \quad (\text{c. g. s.})$$

where: quantities are defined as above except for:

μ , which is normally in this calculation taken to be an absorption rather than a linear attenuation coefficient
 E = Mev
 R/hr = Roentgens per hour
 r = (as defined for flux)
 K = 0.0555, in c. g. s. units
 C = curie strength of source
 n = number of gamma photons per disintegration

This is the basic equation that permits interchange of flux and field strength limits. The former are more useful in defining scintillator count rates; the latter are more directly interpretable in terms of dosimetry problems. Both are quite important.

E. Dosimetry Problems as Related to Field Strength

Information on R/hr may be translated into REM data or similar data permitting an evaluation of the radiation exposure hazards to which crew personnel are subjected. Such calculations have been made, and show that no one man's life will be endangered if the basic survey plan is not pushed to maximum speed in the absence of desirable support facilities, including remote-control opportunities. (Appendix Section VIII-B.)

F. Basis for Shielding Calculations

In general, the more shielding required, the more important it is to make a wise choice of the type and amount of shielding to be used, -- both for the gamma detection equipment and for the personnel involved. In reference to personnel, there are safety standards to be met. In reference to improvements in capability of the gamma detection equipment, there also are goals to be met. Weight of dense metal must be counterbalanced against crew safety and operational opportunities, and this consideration again returns us to the realm of trade-offs. (Graphs VI and VII.)

G. Concept of Scintillator Capture Efficiency

Counts/sec relate very directly to scintillator cross section, but capture efficiency is related more to the type and thickness of the scintillators used. Scintillators depend for their capture efficiency upon depth, density, etc. Their count rate, on the other hand, is influenced by cross section area as well as capture efficiency. That is, a wide area scintillator with little depth will be no more productive than a smaller area scintillator with greater depth. To make the consideration simpler, how many of the gamma photons will be captured? The thickness of scintillator, more than area, will determine capture efficiency. Especially at high Mev levels, crystal thickness is as much or more controlling than wide aperture and large area of the crystals. (See Appendix Section VIII-C.)

VI. RADIOACTIVE BACKGROUND

Any gamma detector must expect to receive radiation not only from primary target sources but also from other sources. These include radioactive debris on the ground, major sources lying near the primary target source, airborne radioactive dust, sky shine due to cosmic rays and very high altitude particulate matter from distant nuclear bomb

explosions, etc. The higher the background level in reference to target source field strength, the longer the counting time required to obtain good statistics or measurement accuracy. It is because of radioactive background that scintillator shielding and collimation are required, of course.

A. Sky Shine and Airborne Dust

The former always is present, but may change from day to day. The problem of relatively low level airborne dust is one that may be expected to decrease with time as the dust gradually settles to earth or is carried to distant locations by wind. That is, airborne dust usually will not be a problem after a few days.

B. Ground Level Radioactive Dust

This is likely to increase with time, especially during the first few days after initial, major contamination of the area. Fall-out as influenced by wind direction and velocity account for this. Novel ways to remove it have been considered in decontamination studies, but these are outside the scope of this report.

C. Contaminating Material of Short Half-Life

Some of the debris and even major target sources may be expected to have a short radioactive half-life in the typical situation. This is both a blessing and a liability. (The former, because overall flux will decrease rapidly with time for the first few hours, days or weeks. The latter, because gamma surveying may have to be repeated at intervals if the time required for decontamination is extensive.)

D. Sources in Close Proximity to Each Other

In the case of two major target sources lying quite close together, and having approximately equal curie strength and gamma energy level, one provides strong background interference while efforts are made to locate the other with precision. It is in such a situation that the availability of a mobile site that can move very close to the two sources is invaluable. Resolution of the two is quite easy at such short distances.

E. Methods of Coping Mathematically with Ground Level Background Sources

These may be considered either from the lumped or distributed parameter viewpoint in making calculations pertinent to background effects. This has been done with good agreement between the two approaches. (See Appendix Section VIII-D of this report.)

Briefly, the technical specifications of the Contract place an upper limit on:

1. the maximum field strength to be expected at 1 meter from a primary target
2. the maximum total field strength at this same point that is to be expected from the single target source plus all radioactive background influences.

In a 3 Mev calculation, it eventuates that a 1500 curie source is needed to provide the 2000 r/hr field at one meter. The additional 3000 r/hr background field, if entirely from ground level sources, can be closely approximated by placing equal strength 1500 curie sources in centers of 2m x 2m squares in a half-circle area about the primary target source at the circle center. This is a convenient result because at no one point in the semicircle is an observation site located closer than one meter to a second major source after having chosen one of them as the primary source for the moment.

Conversely, it may be assumed that this ground level background is due to uniformly distributed radioactive dust across the area of the 1000 ft. radius semicircle, and a curie strength per unit area of such dust may be calculated. To provide approximately the same 3000 r/hr background, this strength is 0.094 curies /cm².

The latter (or distributed) parameter approach is believed to be more versatile for making additional calculations that may be desired at some time in the future.

F. Counting Statistics

To separate the flux due to a primary target source from that due to various background influences, it is necessary to count scintillations over a sufficiently long period of time. This time interval may be seconds or minutes, depending upon the accuracy required. The irregular but statistically-interpretable counts from both target source and background often are expressed in one-sigma or two-sigma limits to define different levels of assurance. Such calculations are well known and easy to make, but possibly a more obvious display of the concept of count rate statistics is presented in Graph VIII. It relates % accuracy in the measurement to primary target vs radioactive background count totals.

In general, counting statistics are not expected to present nearly so great a problem in this contract as in situations wherein rapid relative motion of source and detector require determinations to be made in a small fraction of a second.

Shaping of gamma scintillator shielding and collimation, as required by background considerations, is discussed in a latter part of this report.

VII. EQUIPMENT CONSIDERATIONS

A. Scintillators

1. Choice of Type:

The three common types of gamma scintillators (viz. crystal, plastic, and liquid) have been considered. They differ in respect to emission wavelength, light yield, decay time, energy resolution capabilities, and such factors as fragility, environmental susceptibility, and cost. Maximum size potential is important in some considerations but not in reference to this contract.

All factors having been considered, it was concluded that the better energy (Mev) resolution of an NaI(Tl) crystal overshadows the fact, in this case, that its decay time is considerably longer than that of a plastic scintillator. Largely for this reason, the crystal scintillator is preferred. Such crystals readily are available in a variety of sizes, and may be machined to achieve almost any desired shape.

2. Choice of Size:

In general, small crystal sizes are preferred for close-in work within relatively high radiation fields because they can be shielded and collimated adequately for high resolution without need for large quantities of dense metals. Conversely, the larger crystals are effective at a considerable distance where their high capture efficiency and large cross section area add to count rate in a weak radiation field. (In a strong field, they could overload or "saturate" associated electronic circuitry.) Thus, at a considerable distance, they permit rapid though approximate source location without a high degree of collimation or use of extensive shielding.

Calculations have been made (and experimental tests unrelated to this contract) on NaI(Tl) crystal sizes ranging from 1" x 1" to 9" x 6"; hence, the information needed to assess the performance characteristics of each is well understood. (See VIII-C.) (Graph IV)

To summarize, the smaller crystals are preferred for highly collimated duty whereas the larger ones are more useful for distant observation of gamma sources.

B. Scintillator Shielding

1. Extent and Location of Shielding:

The extent of scintillator shielding relates very much to the expected

location of the survey site in reference to the major sources of gamma flux.

If the scintillator must operate close-in, it requires heavy shielding. This is not too objectionable for a mobile site but could present problems in reference to portable fixed site equipment.

Desirably, shielding should be shaped to conform to the expected directions of background radiation. Protection in all directions from background often represents a needless waste of heavy shielding material. In the situation confronted in this problem, there is a big difference in the shielding demands on the mobile vs the fixed sites. Either type of site is subject to background radiation from above in event of a heavy concentration of airborne radioactive dust. Likewise, background radiation from ground level deposits must be considered by both, but is more likely to affect the mobile source when working close-in. Background radiation from right and left sides may be expected to be a greater problem for the mobile site when working within the contaminated area, and consequently it requires more side shielding than is true of the fixed survey sites that are located outside the area.

Herein lies the attractiveness or capability of a mobile site working within the contaminated area. Its scintillator needs more shielding, but the fact that it is vehicle-carried permits use of somewhat more shielding weight.

At all times it is necessary to shield against "sky shine," which is the radioactivity contributed by cosmic rays, by high altitude movements of debris from nuclear detonations, etc. This variable is not likely to change as rapidly with time as the airborne dust accompanying (at relatively low altitude) the conditions that make the survey necessary.

The larger the scintillator, the more shielding required for a given R/hr field strength. However, the compensating factor is that the larger scintillator is likely to be used at greater distances where field strengths are appreciably reduced. Another factor relates to scintillator decay time, and hence the number of counts/sec that can be accepted without overloading associated electronic circuitry and thereby missing some counts.

2. Type and Weight of Shielding.

As previously mentioned, the extent of shielding depends, among other things, on the field strength and scintillator characteristics. Gamma photon energy level also is an important factor. However, there are

choices in type of dense metal shielding materials that can be exploited to advantage. For example, depleted uranium and tungsten offer interesting advantages over the more commonly used lead shielding. National Lead advises that depleted uranium in suitable physical form is available, and it appears to have a big weight advantage over either tungsten or the more commonly used lead.

The amount of shielding required depends upon:

- a. the size of the scintillator
- b. the field strength immediately outside the shielding
- c. the maximum number of counts/sec that can be accepted
- d. collimation or directivity requirements

Depleted uranium is one of the best gamma shielding materials because it can reduce the gamma radiation levels to a lower value for less weight and at a reasonable cost in portable equipment.

Survey site location, elevated or not, will influence optimum shielding design. See Graphs VI and VII.

C. Scintillator Collimation

1. Choice of Collimating Metal.

Because of the relative effectiveness of depleted uranium in reference to lead, for example, it is preferred for collimation applications. Because of its vulnerability to environmental conditions, it likely will require protective coatings of other metals. This is not difficult to achieve, however. Uranium is available; its cost is not high, and its effectiveness is great.

Tungsten is another but less desirable alternative to uranium, that offers advantages over lead. The choice among these can not be made on the basis of density alone; absorption coefficient values as a function of Mev are of comparable or greater importance.

Material choices are important insofar as they relate to weight and portability considerations.

2. Angular Resolution Considerations.

These relate to one of the most important technical requirements of the Contract. Major target sources can not be located with specified precision unless adequate collimation permits commensurate angular resolution. In this case, the problem is to provide the collimation

(telescope action) needed for the sufficiently high degree of resolution without sacrificing too much count rate. It is a key challenge to the design and engineering of a practicable system.

With the help of depleted uranium, this can be accomplished. Graph 12 is included within this report to indicate the required degree of angular resolution. Fixed sites, not too distant from the contaminated circle, would be responsible for the use of such highly collimated equipment.

The theory of collimation is presented in Appendix Section VIII-E. It is from this theory that the calculations offered in Graphs II and IV are derived. The latter are self-explanatory.

The $\pm 1/3^\circ$ specification in reference to angular location recently has been re-interpreted in terms of ± 5 ft. location of any given target source from its precise point of location. The proposed mobile site that can move into the contaminated area depreciates the importance of this $1/3^\circ$ spec. That is, an alternative but equally significant spec may be considered.

3. Choice of Adjustable Collimation.

It has been explained previously in this report why the mobile site should be equipped with adjustable collimation. This may be accomplished by any one of several methods, (Figures VII, VIII and IX). The preferred one involves a concentric nest of two or three scintillator crystals, all feeding to a common MPT via light pipe techniques. The Polaroid principle appears to be especially applicable here, (high collimation far out; close-in using less collimation,) adjustable according to physical orientation of Polaroid analyzer in reference to the polarizer element. An option* involves use of several individual scintillators, any of which can be "shuttered" to take advantage of the low or high degree of collimation of another.

Light pipes, as required for this kind of operation, are semi-standard equipment.

D. Choice of the Photomultiplier Tube

This is not an especially challenging problem in terms of photomultiplier tube requirements. That is, no great sensitivity or shock-resistant demands are made. Thus, if there is a problem that relates to tube choice, it likely will be concerned with spectral sensitivity and with ease of optical coupling

* The concept here is that of multiple resolution as contrasted to continuously adjustable resolution.

to large, mobile site scintillator units. In some Government contracts the selection of the optimum MPT is a matter of major concern; not so in this one, however.

Any MPT needed for this application can be purchased as a stock item. (The fixed and mobile sites may not use the same MPT design.)

E. Associated Power Supply -- Preamplifier -- Amplifier -- Discriminator Circuitry

These too are essentially stock items. They are "solid state hardware," and are well developed items of equipment. "Window" techniques for Mev evaluation are well known, and necessary hardware is available. Variability in discriminator operation is available, as well as direct MPT anode take-off for d. c. mode operation in high strength fields.

Generally speaking, all of this is pre-designed equipment.

F. Read-Out Devices

All information obtained from survey efforts must have a proper set of readouts if survey time is to be saved and if crew errors are to be minimized. The basic system and the numerous variations on its theme call for a variety of such readouts.

1. Gamma Readouts:

Mev and counts/sec are the most vital quantities, and each can be telemetered. Likewise, angular directions can be transmitted by radio or telemetry. (In this problem situation, jamming is not considered to be an important factor.) All such readouts can be digitalized for computer analysis, if desired.

Count totals, over an integrated time period, also can be digitalized.

2. Visual Readouts:

These may take the form of simple telescopic or binocular observation, or may involve TV or aerial photography presentations. The fixed site data are simple to communicate via radio; the more elaborate observations must be referred directly to a central computation center.

In any and all cases, readouts suitable for computer analysis can be provided by all sites in reference to all important physical quantities.

Visual readouts are of principal importance insofar as they relate to the potentially highly useful procedure of superposition of several plots.

In all cases the gamma information is controlling, but the adjunct of visual aids provides a time-saver of possibly great importance. That is, gamma radiation measurements of curie strength, Mev, and source location are the basic means of target description, but other means of target identification can be useful for "back up" purposes.

In general, readout devices are conventional, and may be accepted as on-shelf items in terms of the desired objectives.

G. Physical Support (Mounting Means) for the Survey Equipment

The fixed site survey positions require a civil engineer's tripod (very sturdy), with customary graduated circle, to perform their function. Essentially this is conventional civil engineering equipment, but may have to be more sturdy than that normally used. This is not thought to be a serious liability, however. The mobile unit may have a problem in reference to levelling its graduated circle, but this is not considered to be a major stumbling block.

Weight of this physical support must be considered in addition to that of the gamma detection and auxiliary visual detection equipment, relative to portability, etc.

H. Equipment Calibration

Although quite important to the ultimate success of the undertaking, it is not expected that equipment calibration (to place three fixed sites in agreement) will be a challenging demand. It is a job to be done, but not one requiring frequent repetition or tedious, time-consuming effort.

I. Availability of Survey Equipment, Especially Optical (Visual) Adjuncts

It is proposed that elementary or basic equipment be made available in whatever areas are most subject to severe contamination. Next, it is proposed that a plan be formulated to drive-in or fly-in any auxiliary equipment that may be needed if the situation is truly a rigorous one. (The concept is -- lots of basic equipment at numerous locations, but considerable auxiliary facilities that can be air-transported to a contaminated site, if and when needed.)

Equipment dimensions should be adjusted to aircraft-carrying potentials.

VIII. APPENDIX

A. In this Appendix Section of the report, there is presented a tabulation that indicates the engineering and equipment costs to be expected in the Phase II development of a two site, simplest possible, basic operating

model of the proposed system. This would not be a prototype model for future manufacture, necessarily, but would be expected to serve quite adequately for proving system feasibility in a field evaluation study. (Development and procurement time estimates are included with cost estimates.)

As is shown in TABULATION I, it has been estimated that the total cost to achieve this next goal will be approximately \$35,000. Completion is likely to require 5 - 6 months after initiation of effort.

In Phase III, mobile site equipment would be added to the two fixed site installations, thus permitting a closer and more desirable approach to the proposed system. Assuming that the vehicle required for a mobile site is available and does not demand extensive chassis alterations to accommodate the system equipment, it is estimated that an additional \$5000.00 (including communication) plus another \$5000.00 for field testing will be sufficient.

Phase IV would be expected to include, additionally, the advantages of:

1. aerial photography and/or TV visual aids, including facilities for superposition of visual terrain, gamma source location, and mobile site location,
2. an on-site analog computer,
3. helicopter guidance to the mobile site,
4. complete remote control of both stationary and mobile sites, from a centralized system control and data computation center.

Equipment and engineering for such a full scale field evaluation of the system, plus complete manufacturing drawings, will (after inclusion of engineering costs) approximate \$75,000 - \$100,000 according to a crude and quite preliminary estimate.

If Phase II proves field applicability of a system already demonstrated to be theoretically feasible, a more detailed and more accurate estimate of Phase III and Phase IV costs will be made.

B. Dosimetry Considerations

One of the implicit, if not explicit, obligations is that of survey crew safety from radiological hazards. Toward that end, and while subordinating the consideration to others of more direct interest, certain calculations have been made.

From the conventional equation relating r/hr to photons/cm²-sec it may quickly be shown that (in c. g. s. units):

$$\frac{(1.51) (10^8) (\text{nC}) (\text{Mev}) (\mu_a)}{r^2} = r/\text{hr}$$

This is a "short air gap" equation, and for appreciable air distances must be multiplied on the left side by $e^{-\mu_o r}$ where μ_o = linear attenuation coefficient in air, and is not to be confused with the μ_a absorption coefficient for air.

Typical μ - values (cm⁻¹) for air are:

	<u>0.5 Mev</u>	<u>10 Mev</u>
μ_a	0.38 x 10 ⁻⁴	0.19 x 10 ⁻⁴
μ_o	1.10 x 10 ⁻⁴	0.26 x 10 ⁻⁴

It is understood that the r/hr specs in this contract apply to a one meter distance from a point source, in which case (for n = 1) the equation reduces to:

$$(1.51) (10^4) (\text{C}) (\text{Mev}) (\mu_a) (e^{-100\mu_o}) = 1 \text{ r/hr}$$

For Mev = 0.5, it further simplifies to:

$$0.29\text{C} = r/\text{hr}, \text{ at one meter}$$

and for Mev = 10, it becomes:

$$2.87\text{C} = r/\text{hr}, \text{ at one meter}$$

From these last two equations it can be calculated that:

<u>r/hr</u>	<u>C, 0.5 Mev</u>	<u>C, 10 Mev</u>
0.5	1.7 curies	0.17 curies
1	3.4	0.35
2000	6800	700
5000	17,500	1750

EQUIPMENT ELEMENTS	TYPE	ENCLOSED WEIGHT	ENG. DESIGN	C O S T S		AVAIL ABILITY
				ONE PROTOTYPE	*FIVE PROTOTYPES	
SCINTILLATOR	** NaI (Tl) - 2" x 2" or 3" x 3"	2 - 3 lbs.		\$2500.00		4 - 6 mo.
MPT	Suitable to accommodate the scintillator	2 lbs.	\$9000.00	\$2500.00	\$6000.00 each	4 - 6 mo.
ASSOCIATED ELECTRONIC CIRCUITRY	As required, excluding power pack	5 - 10 lbs.		\$3000.00		4 - 6 mo.
SHIELDING	Ur, mainly on sides, less metal on top and bottom. Little on back	50 lbs.	\$1000.00	\$ 500.00	\$ 500.00	6 mo.
COLLIMATION	Sufficient to provide ± 5 ft. at 1000 ft.	150 lbs.	\$2000.00	\$ 500.00	\$ 500.00	4 - 6 mo.
VISUAL AIDS	Optical telescope or binoculars	3 lbs.	GFE			At once.
PHYSICAL SUPPORT FOR EQUIPMENT	Sturdy civil engineering tripod	30 lbs.	GFE			3 mo.
POWER FOR EQUIPMENT	Batteries	25 lbs.	GFE			1 - 3 mo.
COMMUNICATIONS	Intercom (wire) or radio	5 lbs.	GFE	\$ 100.00 (special)	\$ 100.00 (special)	1 - 2 mo.
SCANNING CONTROL	Manual, with time rate readout	3 lbs.	\$1000.00	\$1000.00	\$ 500.00	1 mo.
READOUTS	Visual. Count rate, Mev, direction	5 lbs.	\$1000.00	\$1000.00	\$ 500.00	1 mo.
CALCULATIONS	Slide rule, plus special graph paper	2 lbs.	\$ 200.00	\$ 500.00	\$ 200.00	1 mo.
TOTALS:		250 - 300 lbs.	\$14,200.00	\$11,600.00	\$8,300.00	
Expected System Accuracy						
Mev						
Source Location						
Curie Strength						
Relative Time to Complete Survey						
Survey Crew Demands						
Survey-Decontamination Cooperation						
*Costs are per unit. Also weight.						

- ▶ Very good; within specs.
- ▶ ± 0.2 - 0.5 Mev
- ▶ ± 5 ft. at 1000 ft.
- ▶ ± 5 - 25%, depending upon observation time and intervening ob
- ▶ Probably days. This is an inexpensive but relatively slow proc
- ▶ Two men at each survey site
- ▶ Survey is best completed prior to decontamination.

ENCLOSED WEIGHT	ENG. DESIGN	C O S T S		AVAIL- ABILITY	CAPABILITY		
		ONE PROTOTYPE	*FIVE PROTOTYPES		Mev	Location	Curies
2 - 3 lbs.		\$2500.00		4 - 6 mo.	O.K. Avoid going beyond 10^5 counts/sec for NaI (TI)		
2 lbs.	\$9000.00	\$2500.00	\$6000.00 each	4 - 6 mo.	O.K. No vibration requirements.		
5 - 10 lbs.		\$3000.00		4 - 6 mo.	Predicted to be quite adequate.		
50 lbs.	\$1000.00	\$ 500.00	\$ 500.00	6 mo.	Entirely adequate for expected environmental conditions.		
150 lbs.	\$2000.00	\$ 500.00	\$ 500.00	4 - 6 mo.	Sufficient to meet contract specs.		
3 lbs.	GFE			At once.	Readily available to meet the need.		
30 lbs.	GFE			3 mo.	Suitable units available for the job to be done.		
25 lbs.	GFE			1 - 3 mo.	Problems anticipated only at very low temperatures.		
5 lbs.	GFE	\$ 100.00 (special)	\$ 100.00 (special)	1 - 2 mo.	O.K.	O.K.	O.K.
3 lbs.	\$1000.00	\$1000.00	\$ 500.00	1 mo.	O.K.	Good if time is not too important.	
5 lbs.	\$1000.00	\$1000.00	\$ 500.00	1 mo.	O.K.	O.K.	O.K.
2 lbs.	\$ 200.00	\$ 500.00	\$ 200.00	1 mo.	Sufficiently accurate, but time-consuming		
50 - 300 lbs.	\$14,200.00	\$11,600.00	\$8,300.00				
ry good; within specs. 0.2 - 0.5 Mev 5 ft. at 1000 ft. 5 - 25%, depending upon observation time and intervening obstacles. obably days. This is an inexpensive but relatively slow procedure. 10 men at each survey site rvey is best completed prior to decontamination.							

TABULATION I

THE BASIC SYSTEM IN ITS SIMPLEST FORM.

SURVEY IS ACCOMPLISHED BY THREE FIXED SITES AND NO MOBILE SITE.

A GOOD EVALUATION CAN BE MADE WITH TWO FIXED SITES, THOUGH THREE ARE PROPOSED IN PRACTICE.

COST OF ENGINEERING AND THE PROPOSED TWO PROTOTYPE MODELS TOTALS APPROXIMATELY \$35,000.00.



**
Larger scintillators to 9" diameter can be used to decrease survey time. Cost increase per unit will be \$2000.00 each, approximately.

Assume that 100 mr/wk = 100 mrem/wk, is a safe, acceptable dose rate. Assume also an 8-hr day for the survey crew(s), and one day of such work per week. Then, the crew can be exposed to 100 mr/8hr or 12.5 mr/hr. On the average, throughout this 8-hr. period, they then would have to work at distances as defined below:

<u>r/hr @ one meter</u>	<u>1/2 Mev</u>	<u>10 Mev</u>
0.5	6.1 meters	6.3 meters
1	8.5 meters	8.9 meters
2000	160 meters	280 meters
5000	205 meters	380 meters

These tabulated data are presented to provide a "feeling" for the dosimetry problems in this situation. Of course, in emergency situations, they could be expected to operate more hrs/wk or "closer in" to the contaminated area. In the WORST case, under the assumption of the above-mentioned 8 hrs/wk, they need not work far outside the circumference of the contaminated circle.

C. Concept of Scintillator Capture Efficiency

In the assumed absence of background, unshielded cylindrical crystals were considered under the condition of end-on viewing.

Linear attenuation coefficients in air were calculated to be:

$$\begin{aligned}
 &8.4 \times 10^{-5} \text{ cm}^{-1} \text{ for 1 Mev} \\
 &4.65 \times 10^{-5} \text{ cm}^{-1} \text{ for 3 Mev} \\
 &2.6 \times 10^{-5} \text{ cm}^{-1} \text{ for 10 Mev}
 \end{aligned}$$

μ_a values for NaI(Tl) were translated into $e^{-\mu_a X}$ values to become:

<u>Crystal Size</u>	<u>1 Mev</u>	<u>3 Mev</u>	<u>10 Mev</u>
1" x 1"	0.78	0.80	0.74
2" x 2"	0.51	2.64	0.60
3" x 3"	0.47	0.51	0.41

$$\text{Crystal efficiency} = (1 - e^{-\mu_a X})$$

See tabulated information on following page for summarized calculation details. (Source strength chosen not to overload detector equipment, so values are relative in photons/sec and counts/sec columns.)

<u>Meters</u>	<u>Xtal Size</u>	<u>Mev</u>	<u>Photons/sec</u>	<u>Counts/sec</u>	<u>l_e*</u>
10	1" x 1"	3	1.5×10^4	3.0×10^3	420
50	"	"	5.1×10^2	1.0×10^2	78
100	"	"	1.0×10^2	20	35
300	"	"	4.4	0.88	7.3
10	2" x 2"	"	6.0×10^4	2.2×10^4	1150
50	"	"	2.0×10^3	7.2×10^2	210
100	"	"	4.0×10^2	1.4×10^2	92
300	"	"	18	6.4	19.5
10	3" x 3"	"	1.4×10^5	6.7×10^4	2000
50	"	"	4.5×10^3	2.2×10^3	360
100	"	"	9.0×10^2	4.4×10^2	162
300	"	"	40	20	34
10	"	1	1.3×10^5	6.9×10^4	2040
50	"	"	3.9×10^3	2.1×10^3	352
100	"	"	6.3×10^2	3.3×10^2	141
300	"	"	13	6.7	20
10	"	10	1.4×10^5	8.3×10^4	2240
50	"	"	4.9×10^4	2.7×10^4	1270
100	"	"	1.1×10^4	6.6×10^3	630
300	"	"	7.3×10^2	4.3×10^2	161
1000	"	"	1.1	0.63	6.2

* Based on total counts for one minute.

D. Calculations Pertinent to Background Radiation

After a given source has been chosen as the primary target for the moment, all other sources within the area of the contaminated circle may be considered as "background". The magnitude of background environment (permitted by the contract to range as high as 3000 R/hr at a point one meter from a primary target) may be calculated in either or both of two ways. These may be referred to as "lumped parameter" and "distributed parameter".

For a lumped parameter calculation, it was assumed arbitrarily that one-half of the contaminated circle had been cleaned up and that a detector operating "close in" is situated at circle center. The remaining half circle area was divided into squares of 2 - meters on a side, and a 1500 curie source was assumed to be positioned at the center of each such square. (3 Mev.) In no case, then, is it necessary to assume a detector location that is closer than one meter to a background source when operating at one meter from its primary target source of 1500 curie strength.

The nearest 21 such background sources were considered, with the primary 1500 curie source only one meter from the detector. Assuming unity contribution from the primary source, these "nearest 21" secondary or background sources contributed a total of 1.18, with the most distant of the 21 adding only 0.02 to the total. That is, series convergence was rapid at this 3 Mev level. If time were spent in establishing suitable mathematical series to be summed for a maximum total background effect, it is most unlikely that the overall summed effect would exceed 1.5, and probably would be under this figure because the calculations assumed only the inverse square law and ignored the exponential air attenuation term.

The somewhat startling conclusion, then, is that a maximum source strength could be located at the center of each such square within the half circle, and not exceed the defined maximum of 3000 R/hr from collective background sources!

This conclusion seemed to be sufficiently interesting and important to justify a confirmation effort using distributed parameter principles.

The same circle - center detector location was chosen, and background material was assumed to be spread uniformly as a thin layer of dust over the half circle, with C curies per sq. cm. This permits use of an equation of the form:

$$\begin{aligned} P' &= k \int_{-\pi/2}^{\pi/2} \int_{r_1}^a \left(\frac{C'}{r^2} \right) (e^{-\mu_0 r}) (r d\theta) dr \\ &= kC' \int_{-\pi/2}^{\pi/2} d\theta \int_{r_1}^a \frac{e^{-\mu_0 r}}{r} dr \end{aligned}$$

where: a = radius of circle
 μ_0 = lin. atten. coeff. in air
 $(3.7)(10^{10})$
 $k = \frac{4\pi}{4\pi}$
r is measured in cm.
 P^1 = background photon/cm² -sec
P = primary source photons/cm² -sec

Upon integration, the above equation assumes the form:

$$P^1 = (\pi K C^1) \ln r - \mu_0 r + \frac{(\mu_0 r)^2}{4} - \frac{(\mu_0 r)^3}{18} + \frac{(\mu_0 r)^4}{96} - \dots \quad a$$

r_1

Because of the $\ln r \log_e r$ term, we can not assume $r_1 = 0$ without encountering mathematical difficulties. However, if we integrate r from one meter to 1000 ft, we find that C^1 must equal 0.18 curies/cm² to provide a P^1/P ratio of 3/2. Or, if we integrate from one centimeter to 1000 ft, C^1 now becomes 0.094 curies/cm². Or, we have changed C^1 by a factor of 2, merely by including the half circle of one meter radius that lies nearest to the detector.

If next we multiply these two C^1 values by 4×10^4 * and compare to 1500, we find a 4.8 ratio when $r_1 =$ one meter, and a 2.5 ratio when $r_1 =$ one centimeter. This is good agreement between the distributed and lumped parameter approaches to the problem, and the lack of even better agreement is attributed largely to the fact that the near half of any 2m :: 2m square exerts a greater influence on P^1 than the far half of the same square.

An advantage inherent in the distributed parameter approach is that it facilitates calculations when the detector is relocated in reference to the circle center.

E. Theory of Collimation

Obtaining the best possible collimation and resolution within the limits of allowable shielding weight is one of the more difficult technical challenges offered by this contract.

Spherical shields have been considered as a first order approximation. However, the more practical goal should be a shield in which some weight of material is sacrificed at the back end, top and bottom of the Xtal in order to save metal that can be used for collimating purposes. This trade-off is an especially inviting one if the system modus operandi calls for moving in toward the circle from a distance, and decontaminating concurrently with surveying.

* A conversion value calculated from information obtained from Mr. Robert H. Niell of Radiological Health Laboratory, Public Health Service, Dept. of Health, Education & Welfare, Rockville, Maryland.

For a simple start on the calculations, it was elected to encase small spherical and cylindrical crystals in a 200 lb. spherical Ur shield, and then to drill a cylindrical hole toward crystal center to expose it, much like a finger hole in a bowling ball. This hole then functions as a crude collimator. When working in close to the 1500 curie source (10 meters and 3 Mev) it was calculated that the hole cross section could be only a few tenths of one cm^2 if overloading of the scintillator - photomultiplier is to be avoided. Rate of change of background to primary target counts/sec varies with distance, of course, and with choice and location of background sources in reference to primary source. Such calculations primarily served the purpose of "providing a feel" for the situation, and consequently are not reproduced in mathematical detail in this report.

The next step was to consider the merits of using 50 of the 200 lbs. of Ur shielding for collimation purposes specifically, acquiring it by reshaping the crystal shield according to the principles stated above. A 1" x 1" crystal and 3 Mev radiation were used for the calculations.

Two vertical and parallel slabs of shielding material were chosen for collimation. Considering the collimation and resolution problems from far out, a source - detector distance of 300 meters was chosen. At such a distance, to spot a point source target to within ± 5 ft., the requirement is ± 18 minutes or about $1/3^\circ$. For a background or secondary target located 2 meters from the primary target along a line perpendicular to the viewing direction, the angle is approximately 23 minutes. (25 minutes used for calculation purposes.)

For 50 lbs. of Ur having a density of 18.7 gm/cm^3 , the volume of each of the two slabs must be 610 cm^3 . (The 50 lb. limitation is consistent with a desire to hold total weight to as little above 100 lb. total as is possible. This is consistent with equipment portage by two men on the survey team.) One must be somewhat arbitrary in apportioning this volume among length, height and width of the slab. Referring to Figure VI, note that

$$\frac{G'}{\cos \theta} + Y = G, \text{ and}$$

$$Y = L \tan \theta$$

or,

$$G' = G \cos \theta - L \sin \theta$$

The unimpeded flux to the crystal is given by:

$$F = G' H I, \text{ where}$$

H = slab height

I = photons/ cm^2 -sec

And the U_r - attenuated flux (neglecting slab and effects if L is long enough) is given by:

$$Q = (IHL) (\sin \theta) \left(\frac{-0.700W}{\sin \theta} \right)$$

where W = slab thickness

$$\text{Total flux} = F + Q$$

If scintillator operates near ground level, H need not be greater than crystal dimension; hence, let $H = 3$ cm for a 1" x 1" crystal. The quantity W appears in an exponential term that can range only from 0 to 1. Hence, it doesn't appear to be as important as other quantities when operating at appreciable distances from a target source. Let $W = 1$ cm. These choices of H and W permit L to be 203 cm. Because of crystal size, it was decided to make $G = 2.5$ cm to obtain a more desirable count rate for this small crystal. The angle $\theta = 0^\circ$, when collimator is aimed "dead on" at the primary target source.

With these conditions, and using the above equations, Graph X was plotted to represent the case of a single source. It resembles the expected, typical "cosine" curve. Next, with a second or background source located approximately 2 meters from the primary source, calculations were made to permit assessment of the combination of sources on count rate vs angle. In this case, most of the resolution has been lost. HOWEVER, the very fact that the curve is reasonably flat is a "tip off" that the detector probably is sighting two closely spaced sources of nearly equal Mev level and curie strength. Hence, such a curve, despite lack of resolution, can be informative in a practical sense. It is true that curie strength can not be defined unconditionally because of possibilities for source confusion, but probability also is that two or more fixed sites, pointing at the same major target, will convert possibilities to high order probabilities very quickly.

At this stage in the collimation - resolution study, it became quite apparent that a high degree of resolution at a distance of 300 yards will be quite difficult within the limitation imposed by available collimation shielding weight.

Multiple crystals with vertical slab shield panels were investigated next. Here, there is a gain because of closer slab spacing, but an associated loss due to reduced collimation length. The net result is no improvement in resolution provided that total slab weight does not exceed 50 lbs., but an opportunity exists to increase total counts through use of a larger crystal. A "fancier" but perhaps no more practical arrangement of multiple crystals is shown in Figure VII, which shows provision for a retractable crystal

array as the detector is moved closer to the area of contamination. This retractable feature might preserve angular resolution without inviting a rapid increase in the ratio of background to primary target counts/sec.

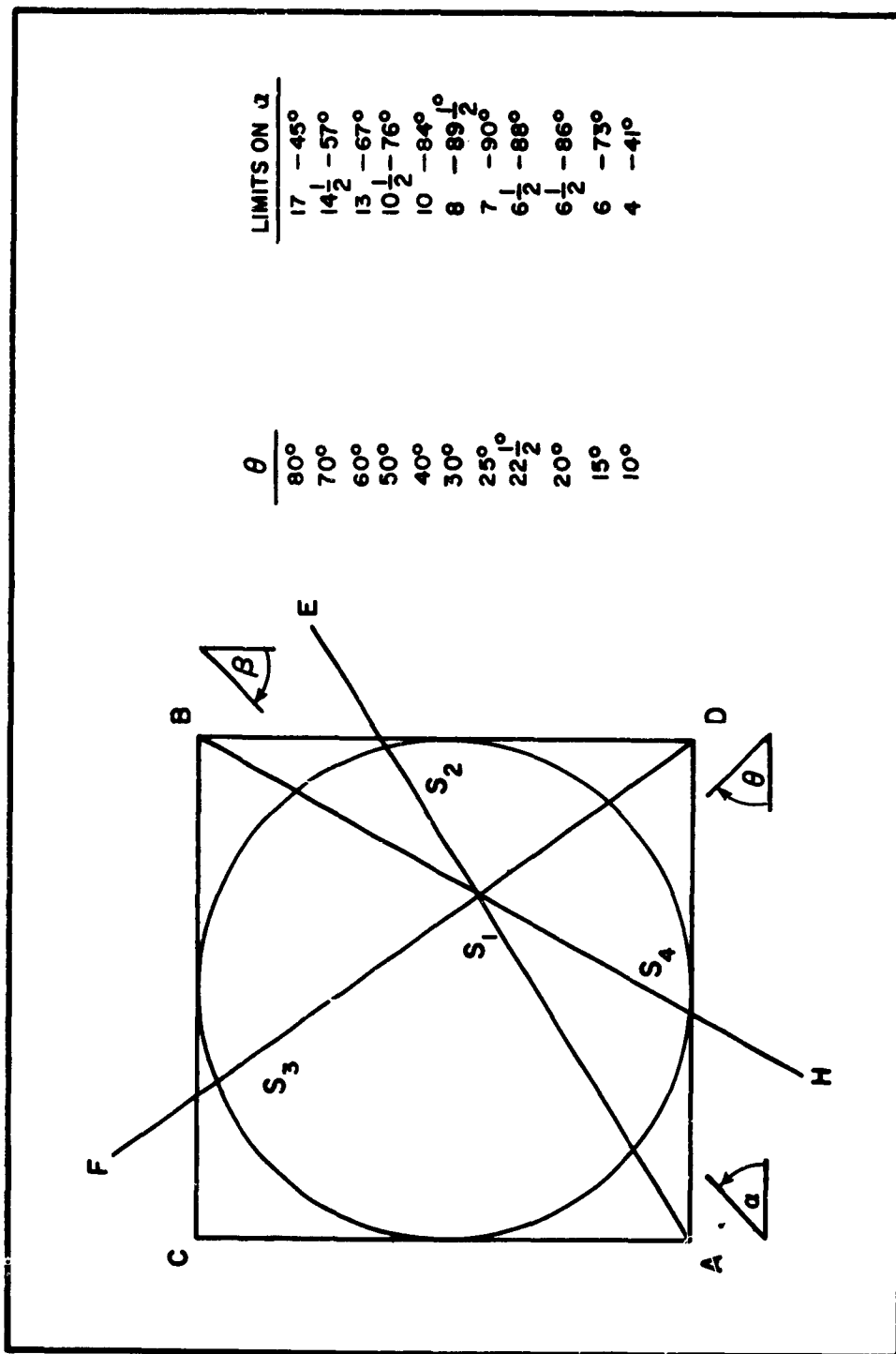
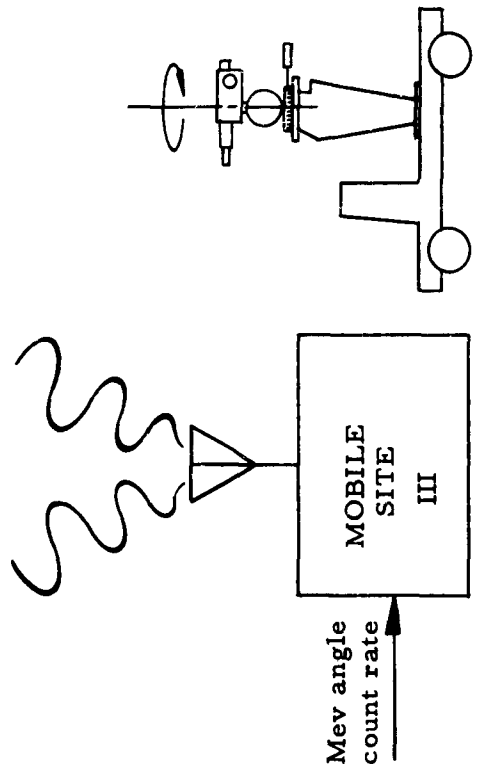
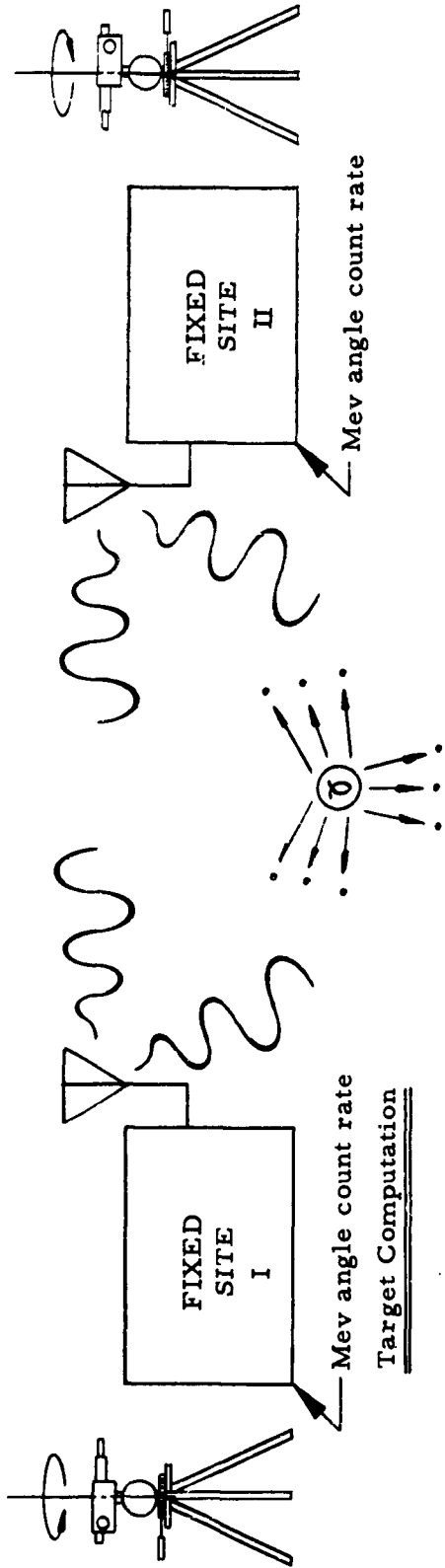

Figure 1. A strong source at a distance can appear to be the equivalent of a weaker source at a closer distance.



- Features:
- Gamma Detector Plus Visual
 - Battery Power
 - Manual Control
 - Voice - Communication

Basic Procedure

FIGURE II

Features:

- Gamma Detector plus TV
- Battery Power, Ground Units. Manual Control.
- Voice - Communication

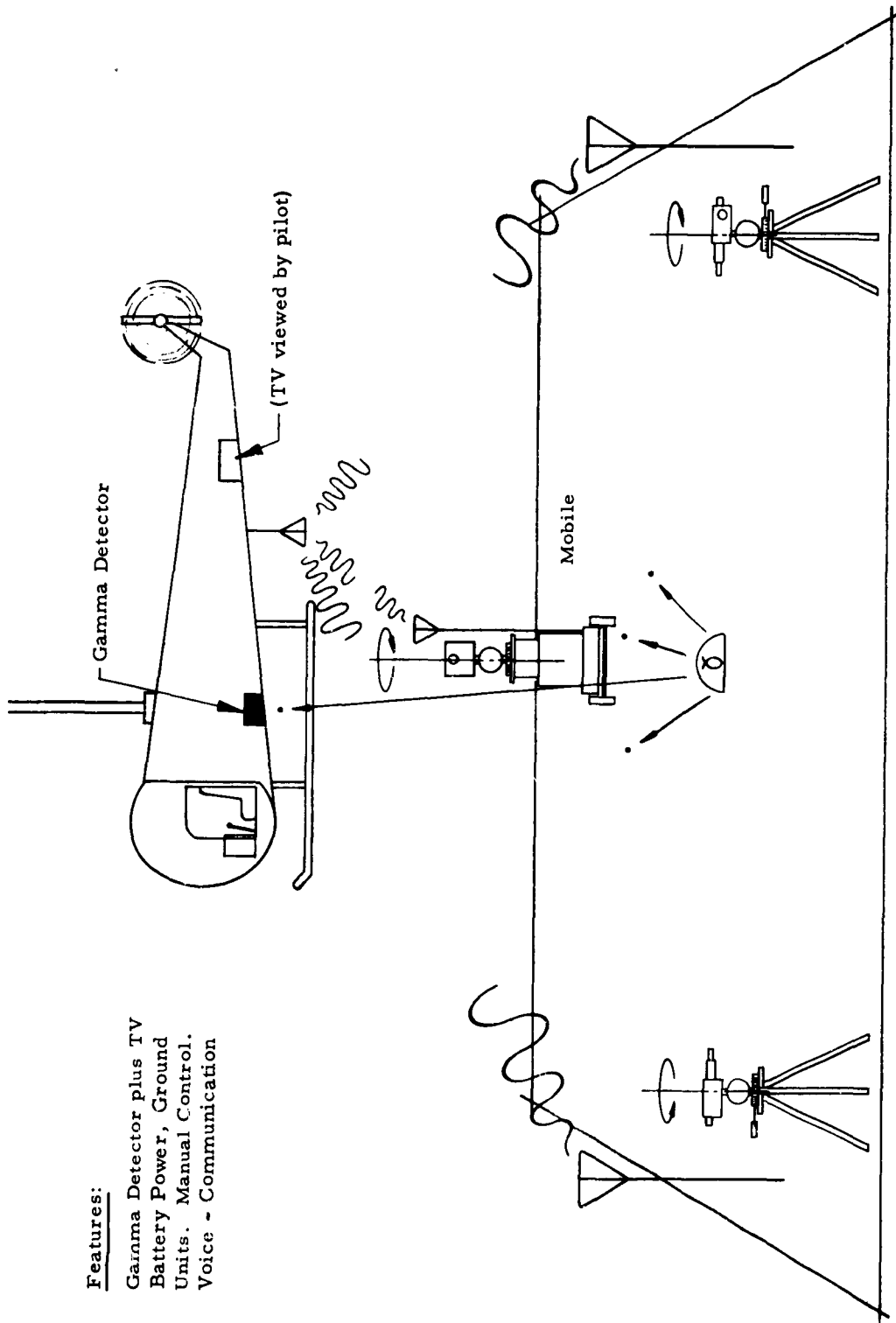

Another Alternative Procedure
(Aerial Aid to Mobile Unit)

FIGURE III

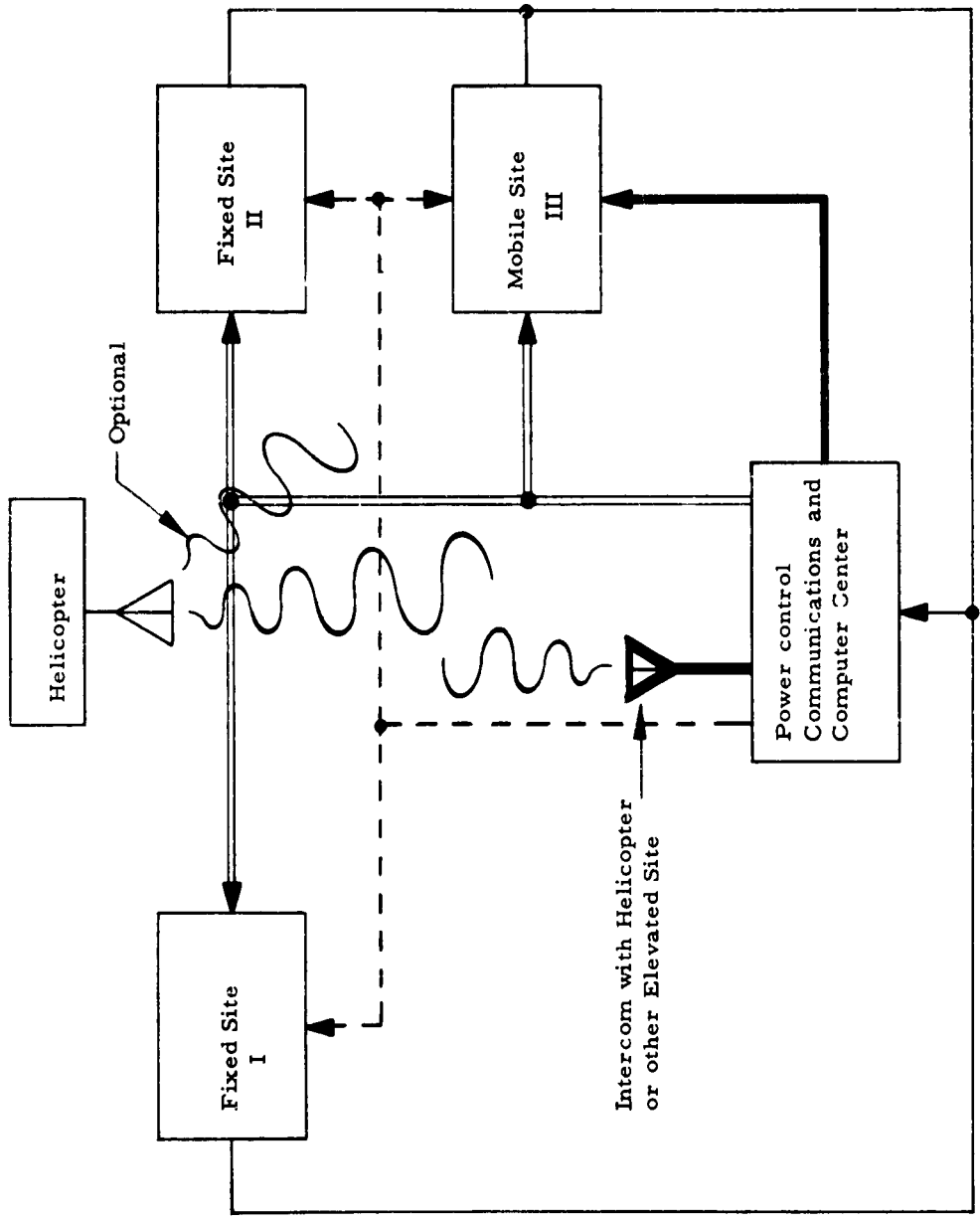

An Alternative Procedure
 (Remote Control From Operating
 Center)

FIGURE IV

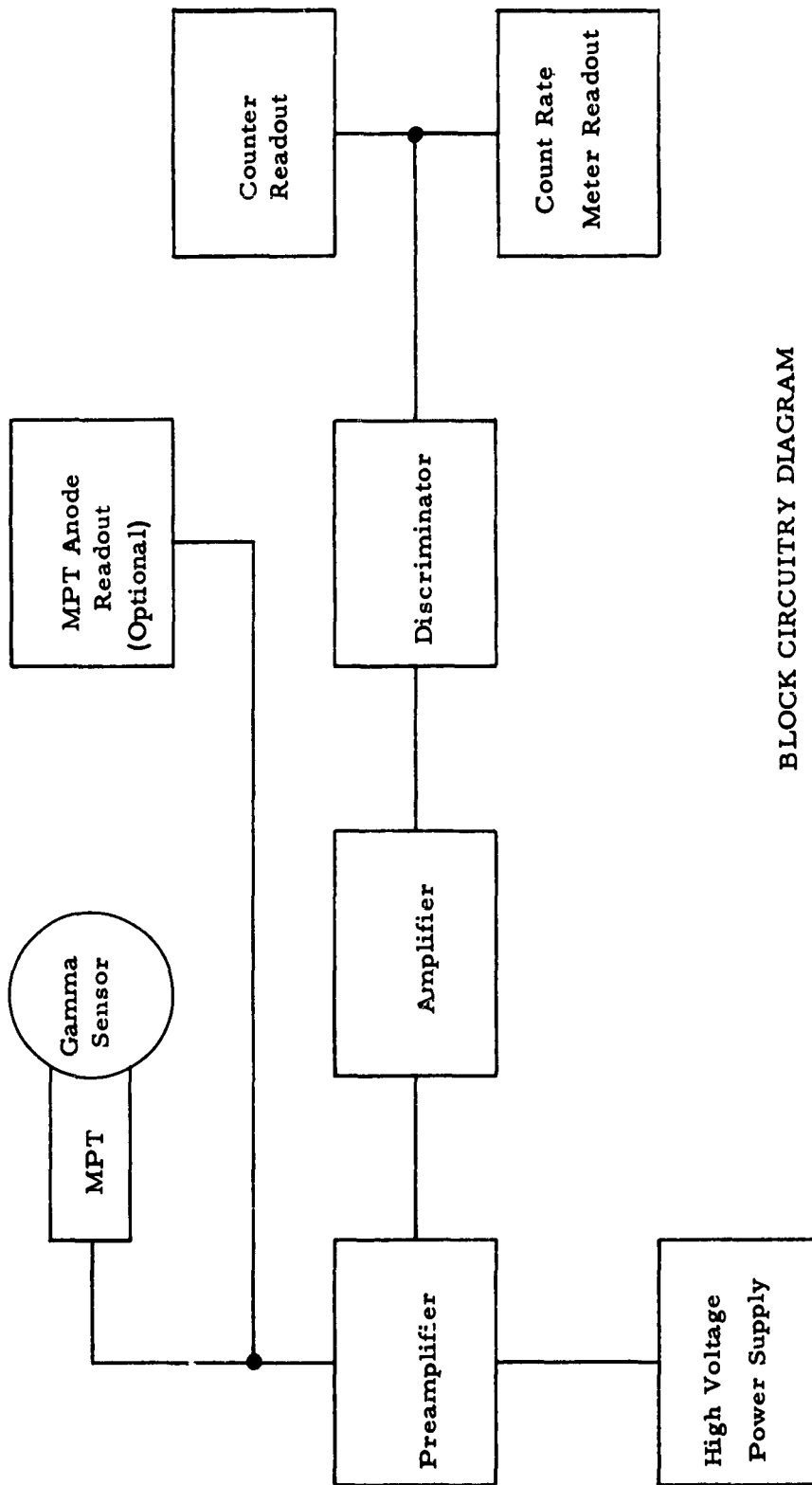

BLOCK CIRCUITRY DIAGRAM

FIGURE V

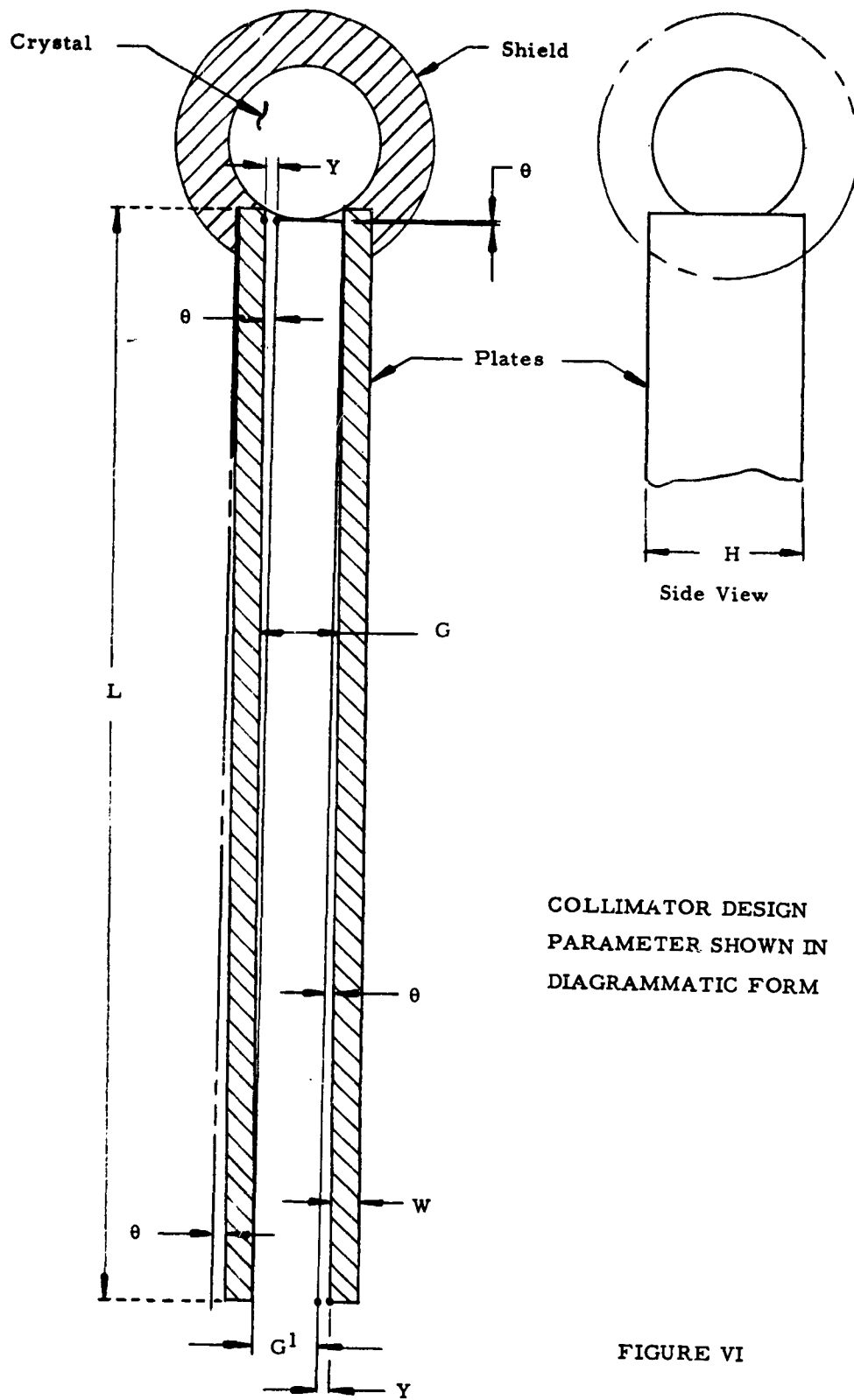

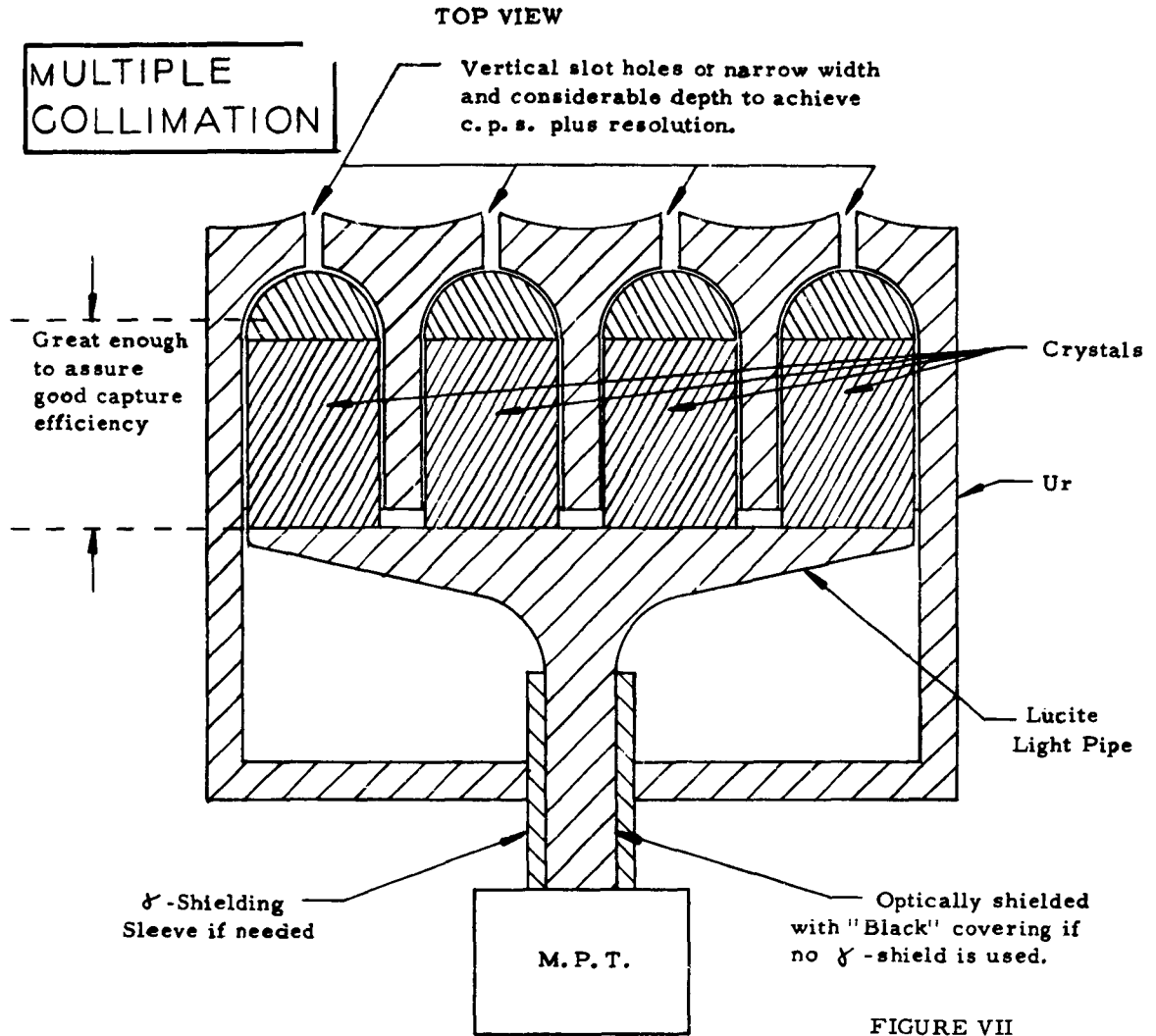

FIGURE VII

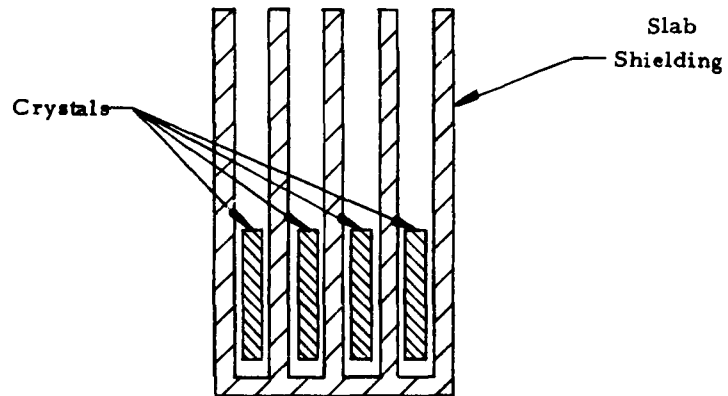

FIGURE VIII

**CONTINUOUSLY ADJUSTABLE COLLIMATION
& SENSITIVITY WITH VARYING SOURCE-
DETECTOR DISTANCE
(USING POLAROID FILMS)**

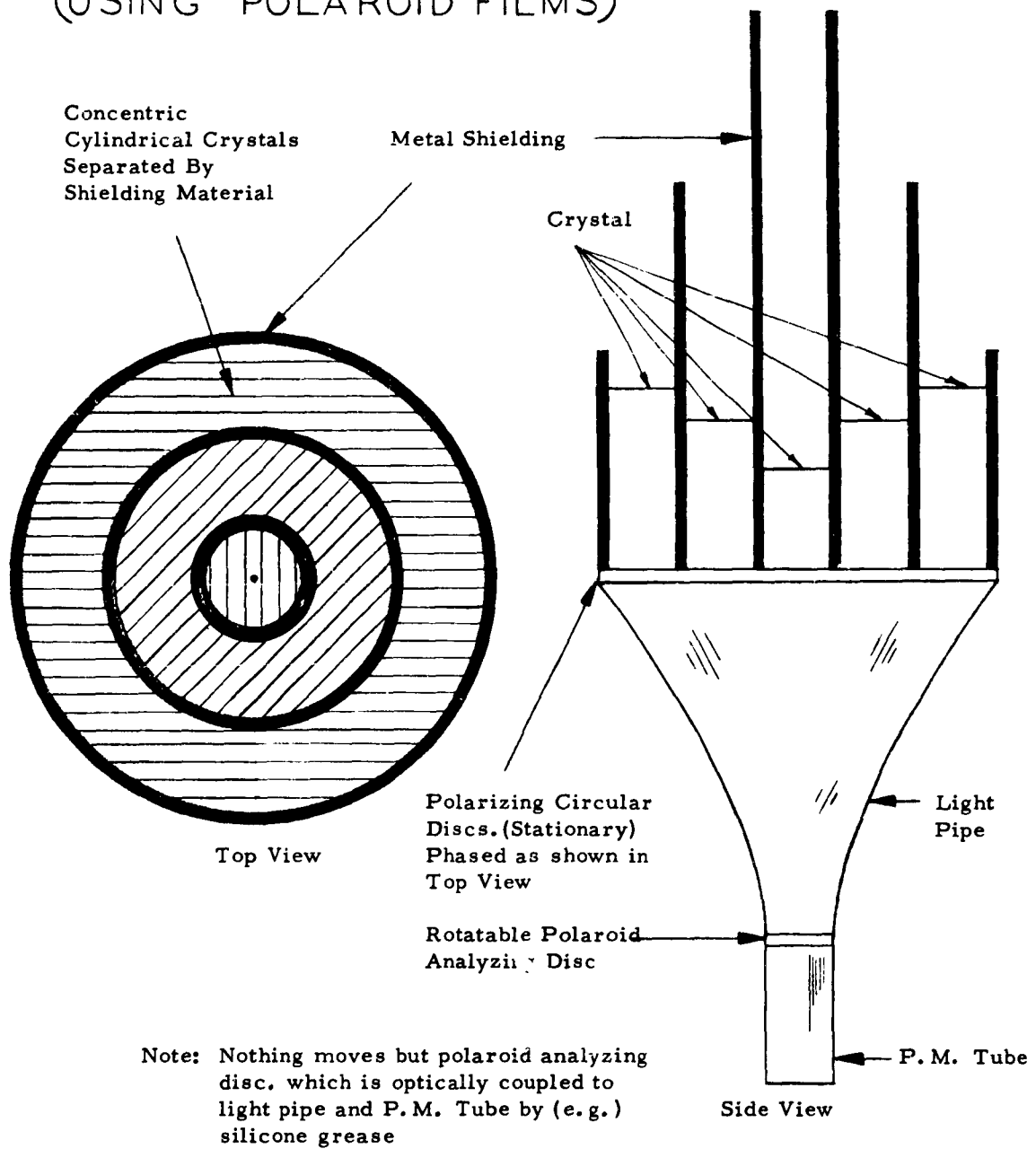
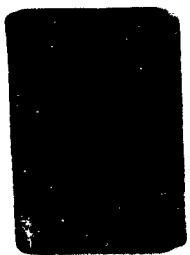
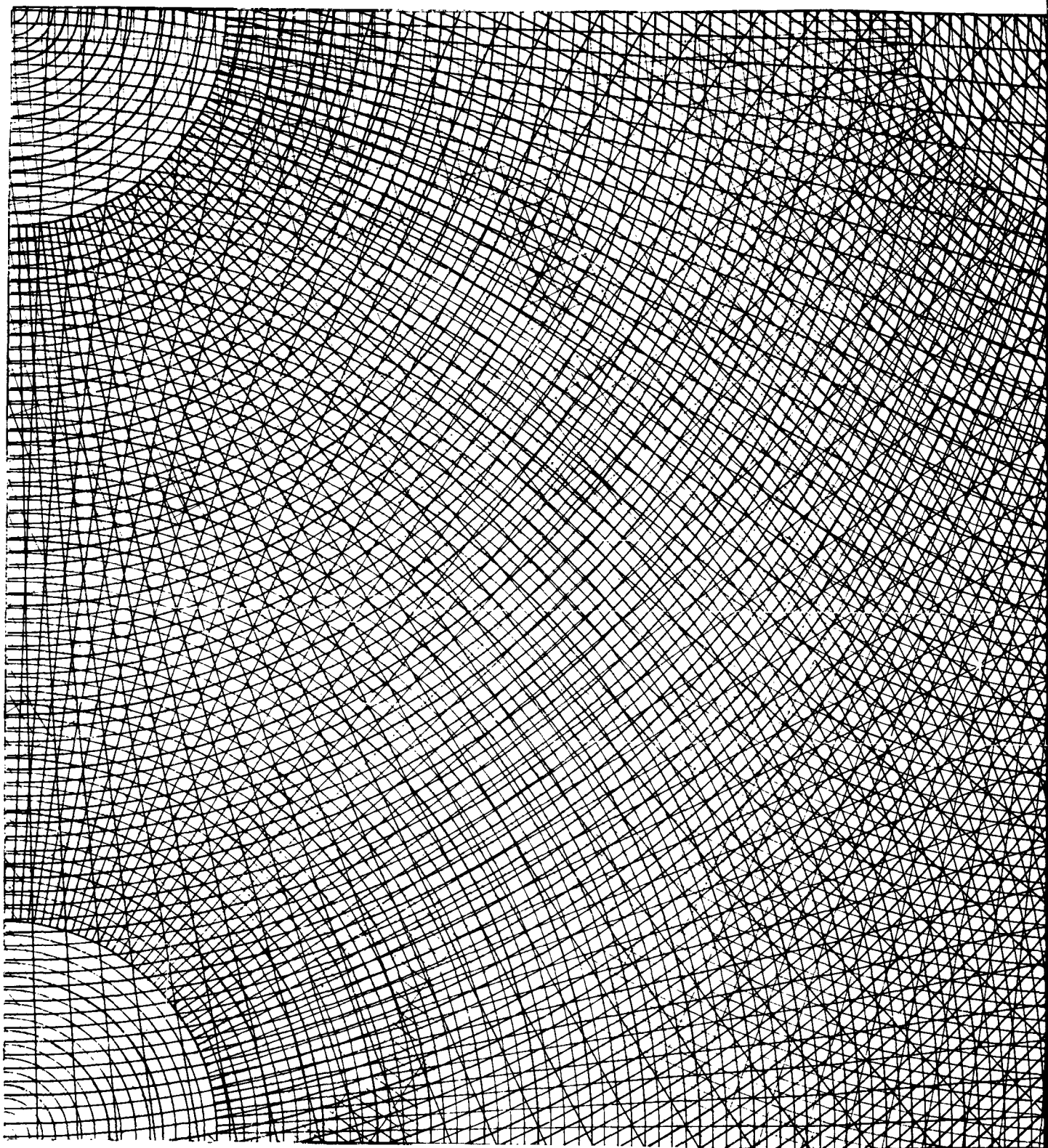
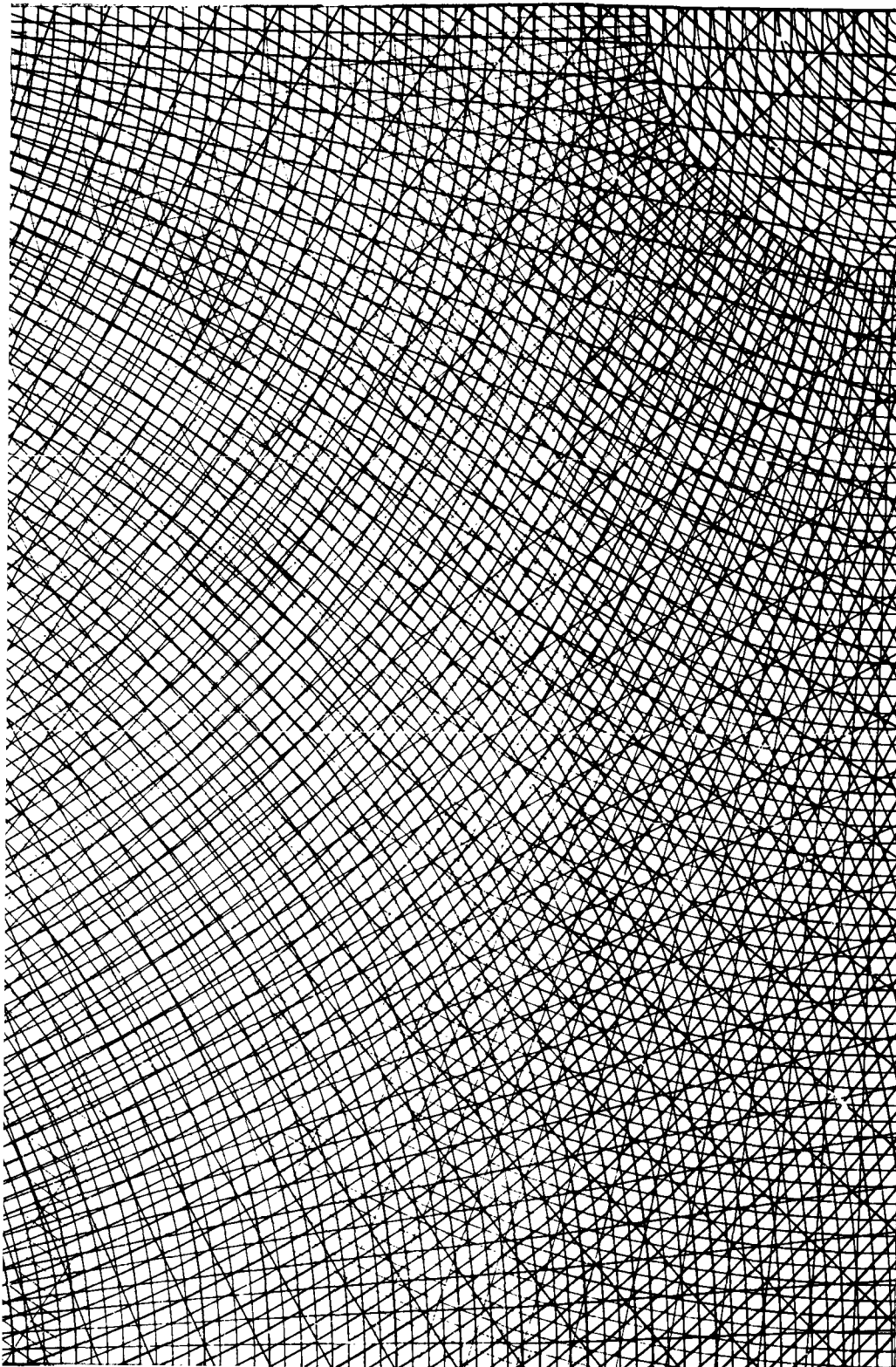

FIGURE IX





GRAPH I

**"TRI-POLAR COORDINATE
GRAPH PAPER**

To be used in facilitating basic survey with three fixed survey sites,

These three sites to be on three corners of the square.

Sides of square may be tangent to contaminated circle or may be outside periphery of the circle.

Angular arcs to be labelled in terms of counts/sec, with radial lines designating angular position of a target source."

Computer - calculated contours of constant ratio of field strengths at two adjacent sites could substitute for circular arcs based upon pole locations.



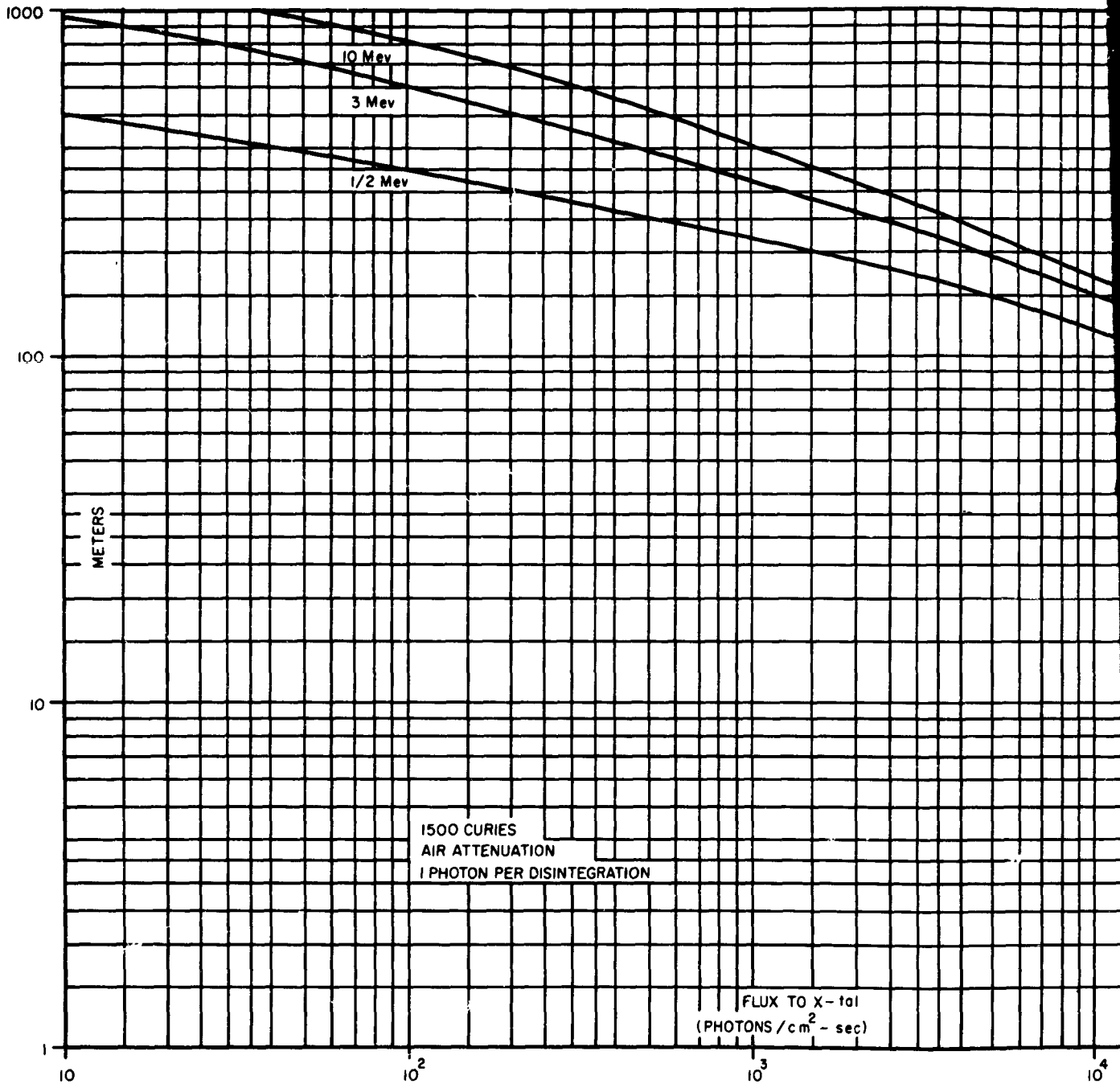

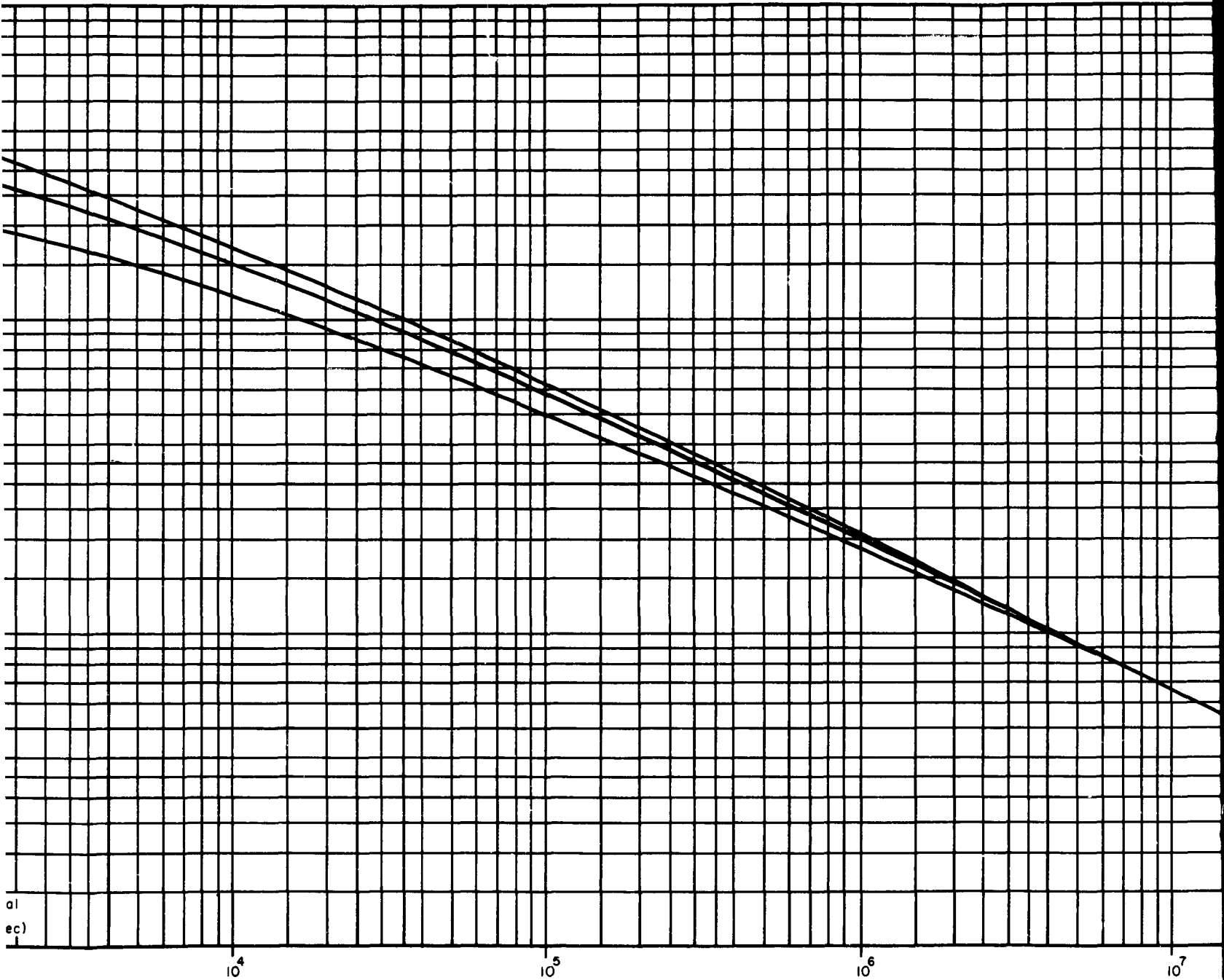

al
ec)

Graph II. Flux to scintillator surface vs. distance from source



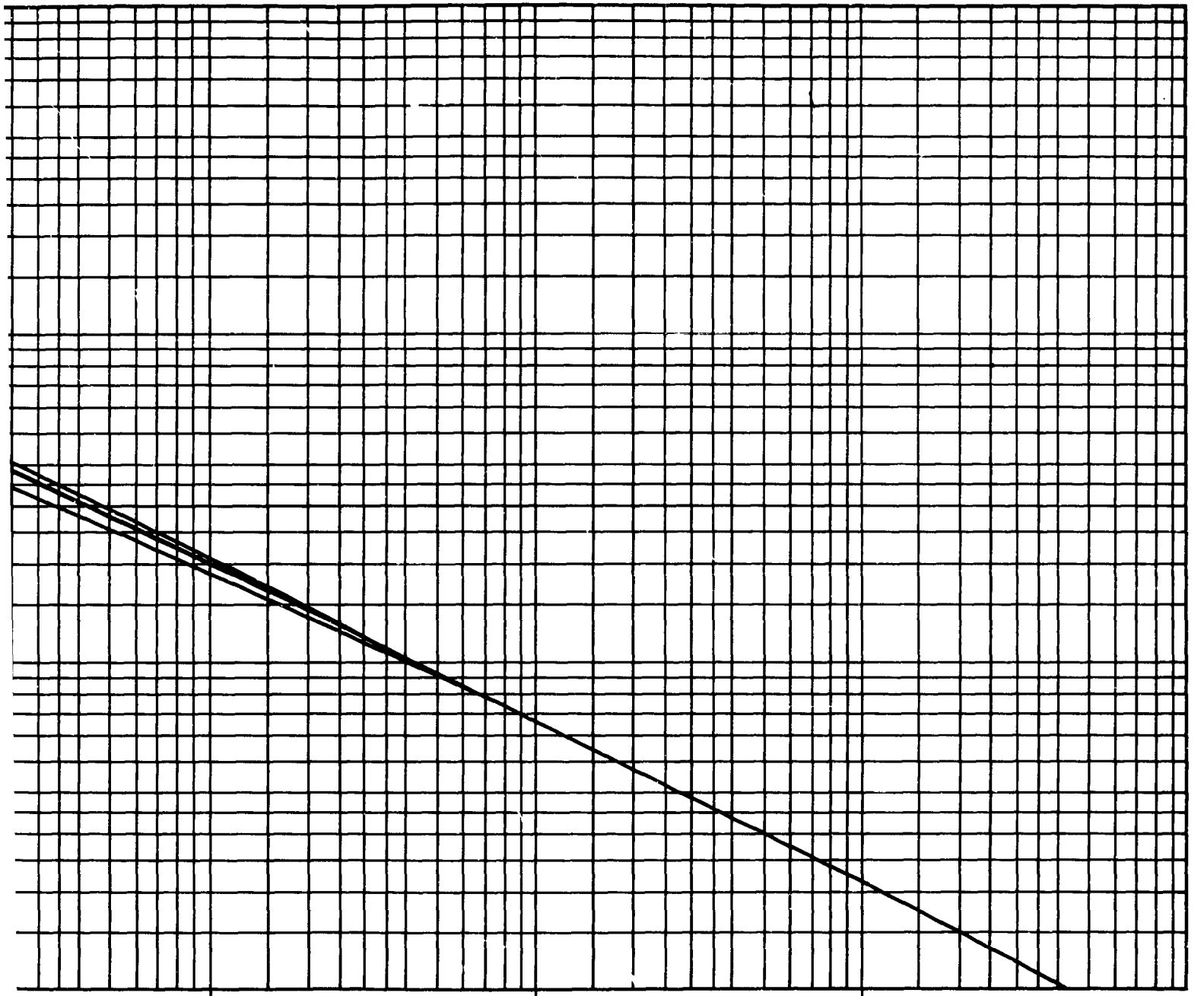

ance from source 10^6 10^7 10^8 10^9



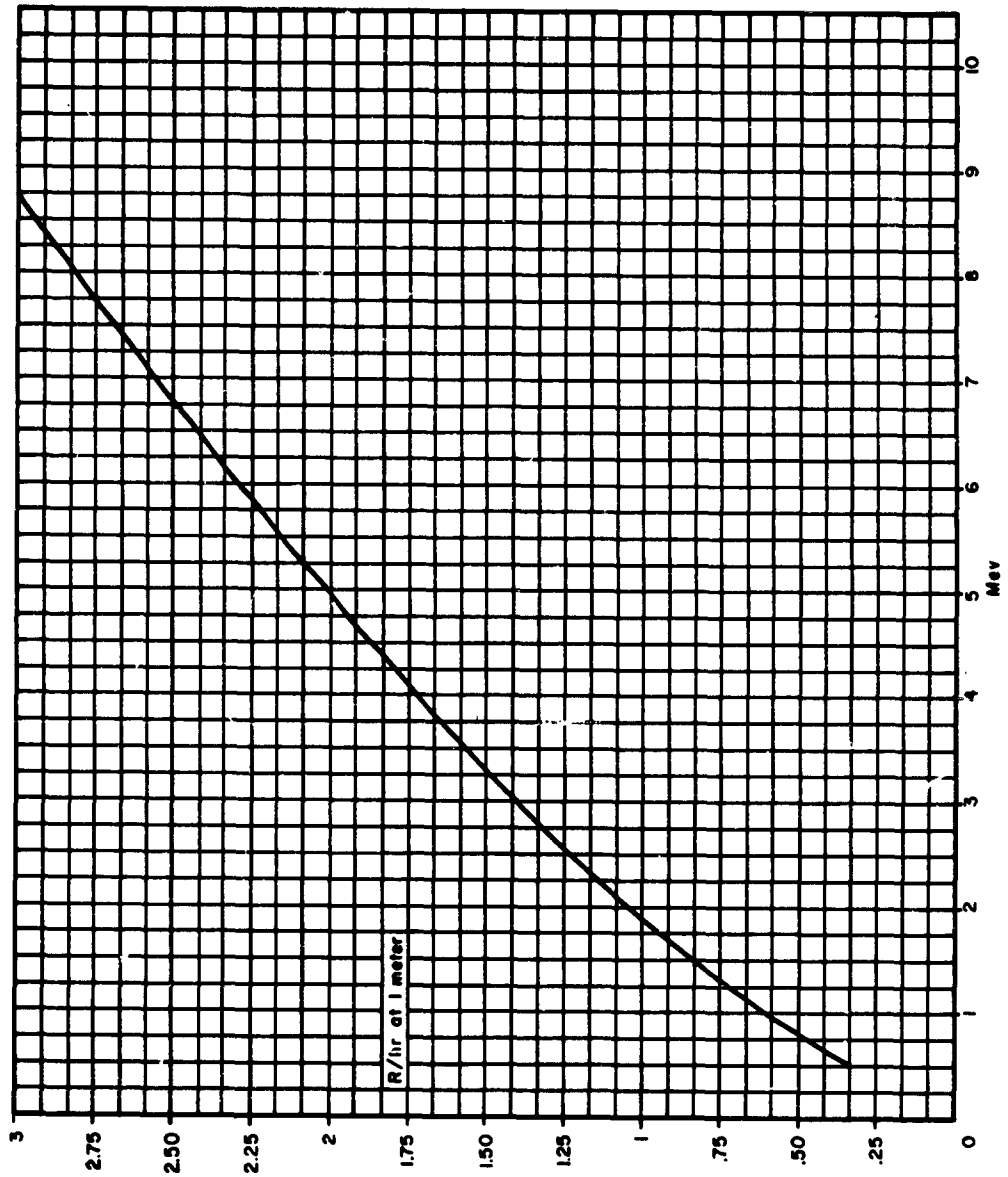

Graph III. Relative field strength at 1 meter vs. photon energy level

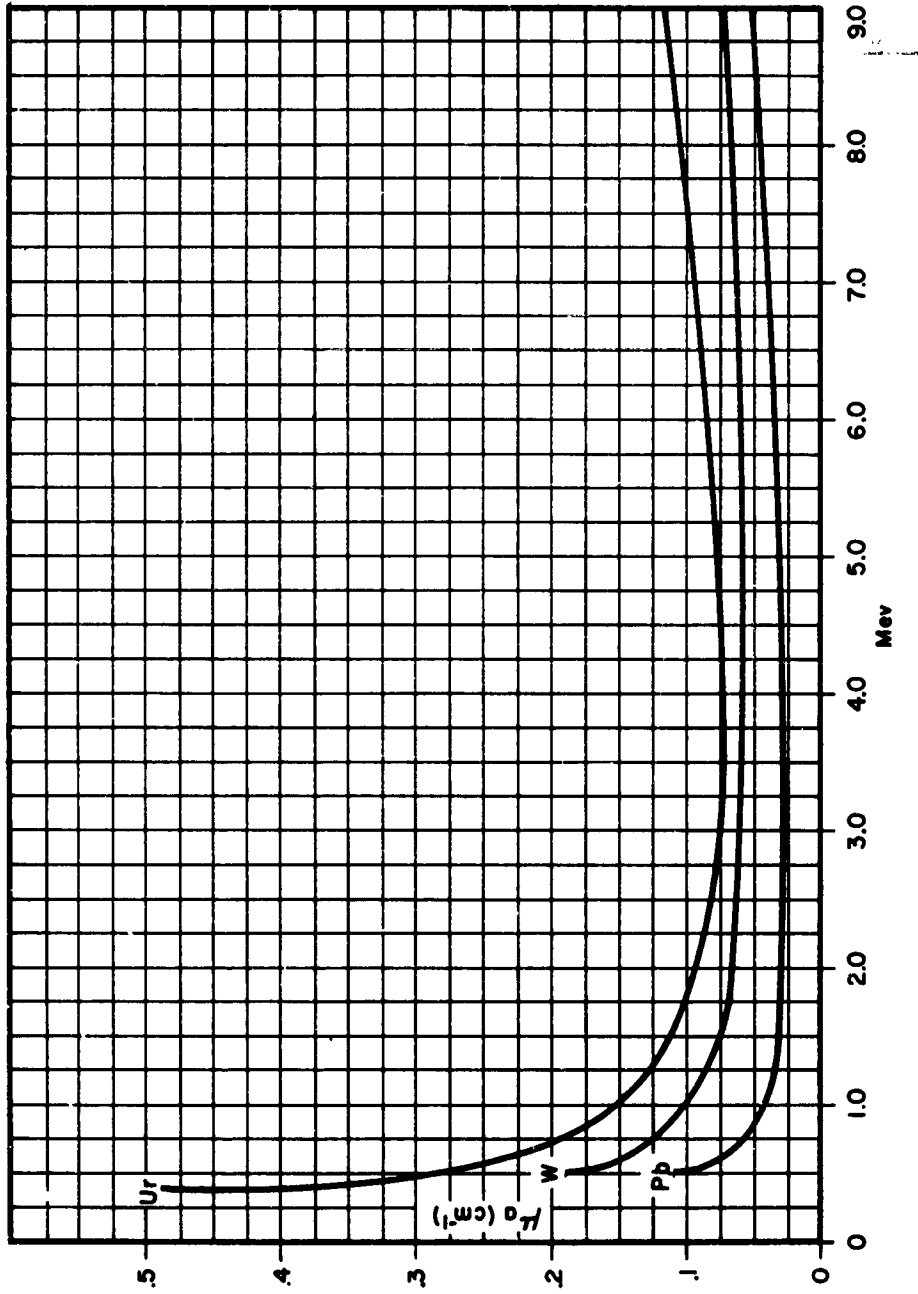

Graph IV. Linear absorption coefficient vs. Mev for Ur, W and Pb

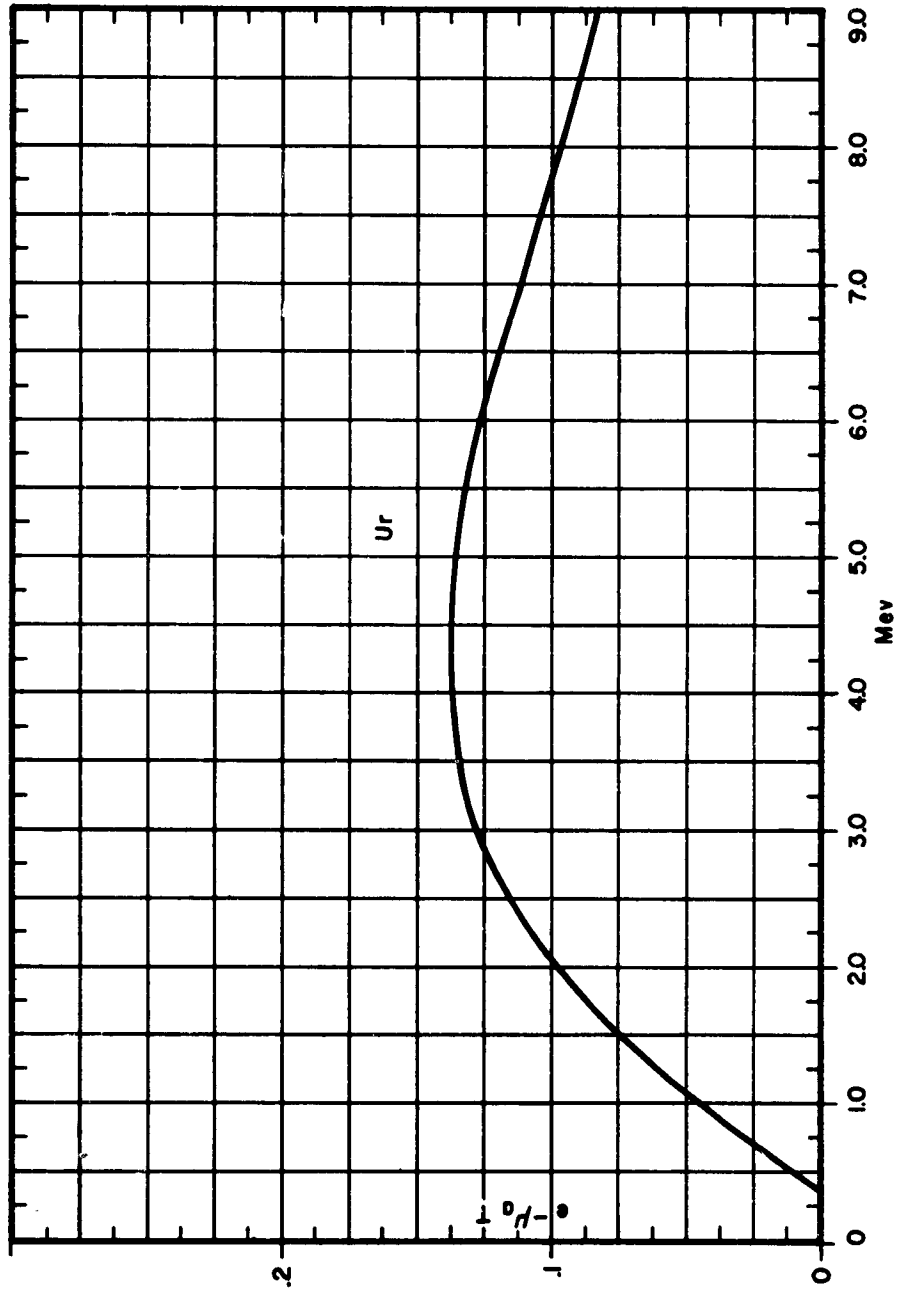

Graph V. Unity minus $e^{-\mu x}$ represents relative shielding efficiency for a given 1 inch effective thickness of Ur shield vs. Mev.

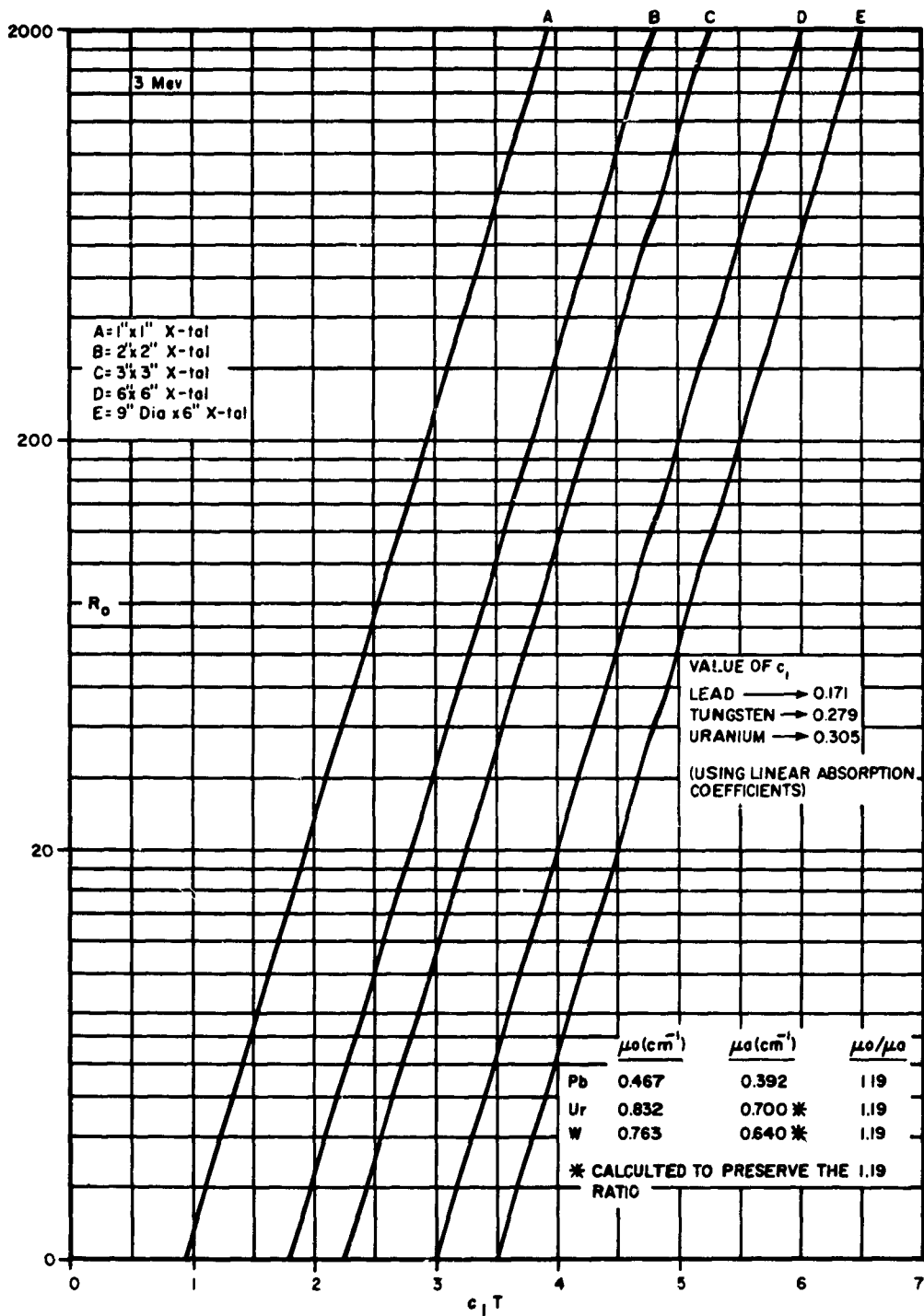

Graph VI. Roentgens/hr vs. shield (cm) thickness for 10^5 counts/sec in NaI (Tl)

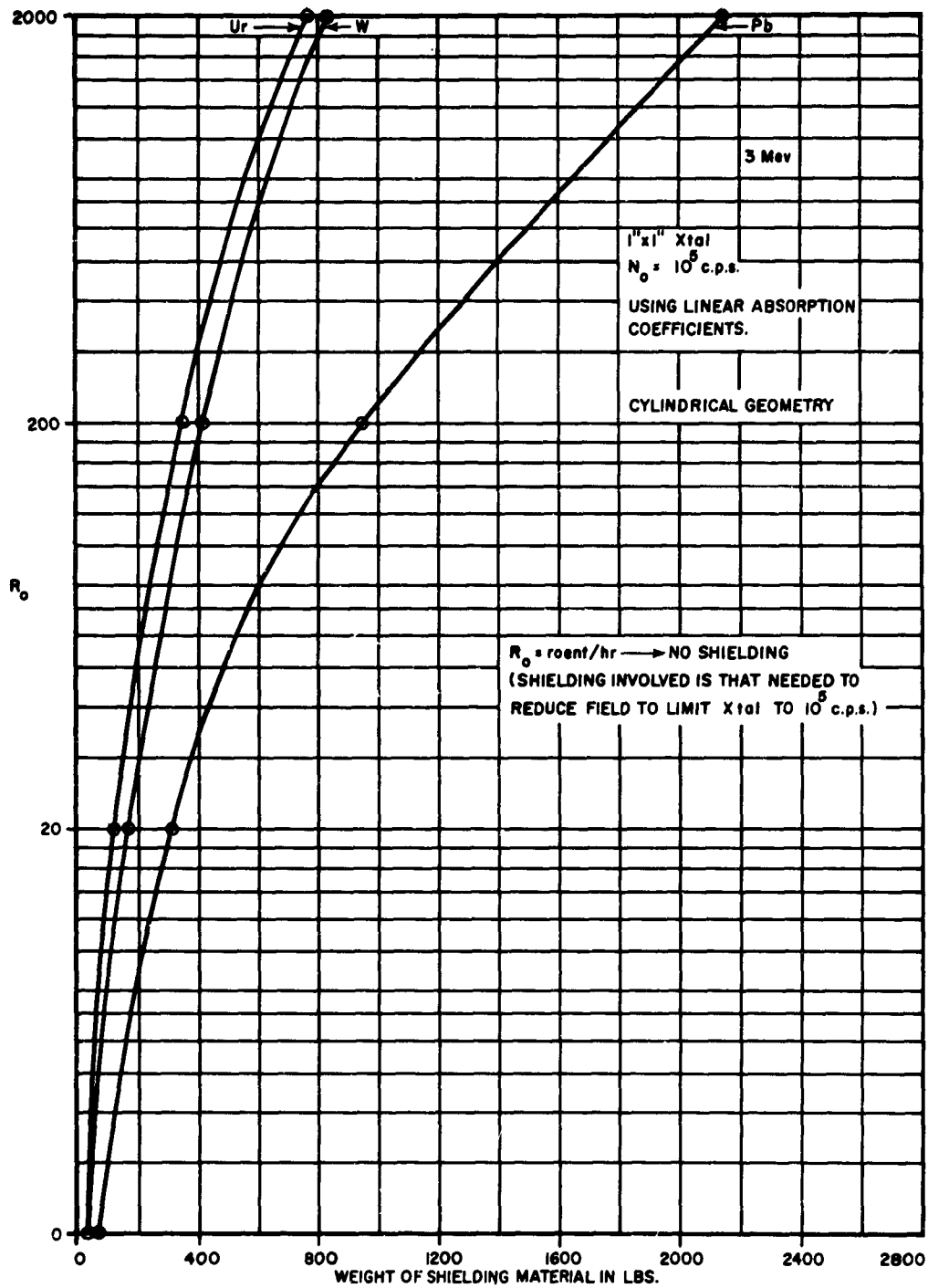

Graph VII. Shielding material necessary to reduce gamma field strength for A 1'' x 1'' crystal to 10^5 cps

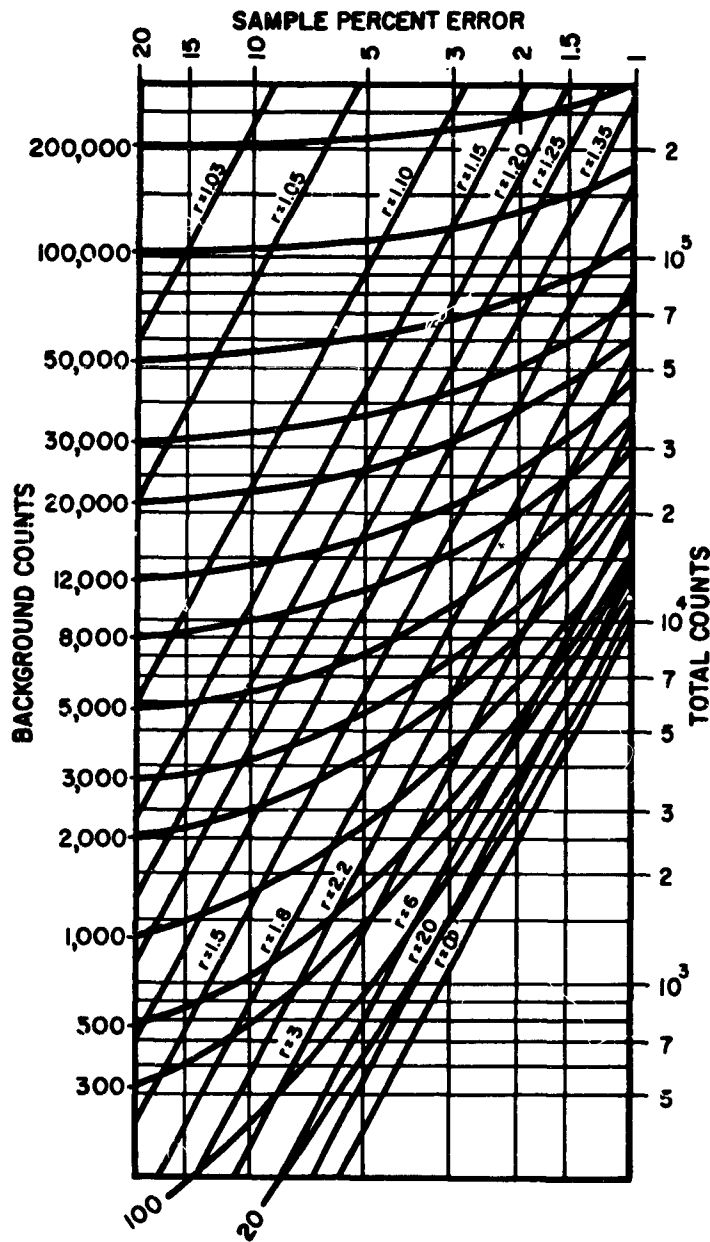

r = ratio of sample plus background counts to background counts.

Intersect any curve of constant r with a vertical line drawn at desired sample percent error. Move horizontally to the right to find total counts required. Then interpolate by sliding between adjacent contours of constant r to determine an intersection on the background count axis.

Graph VIII. Background counts as a function of sample percent error

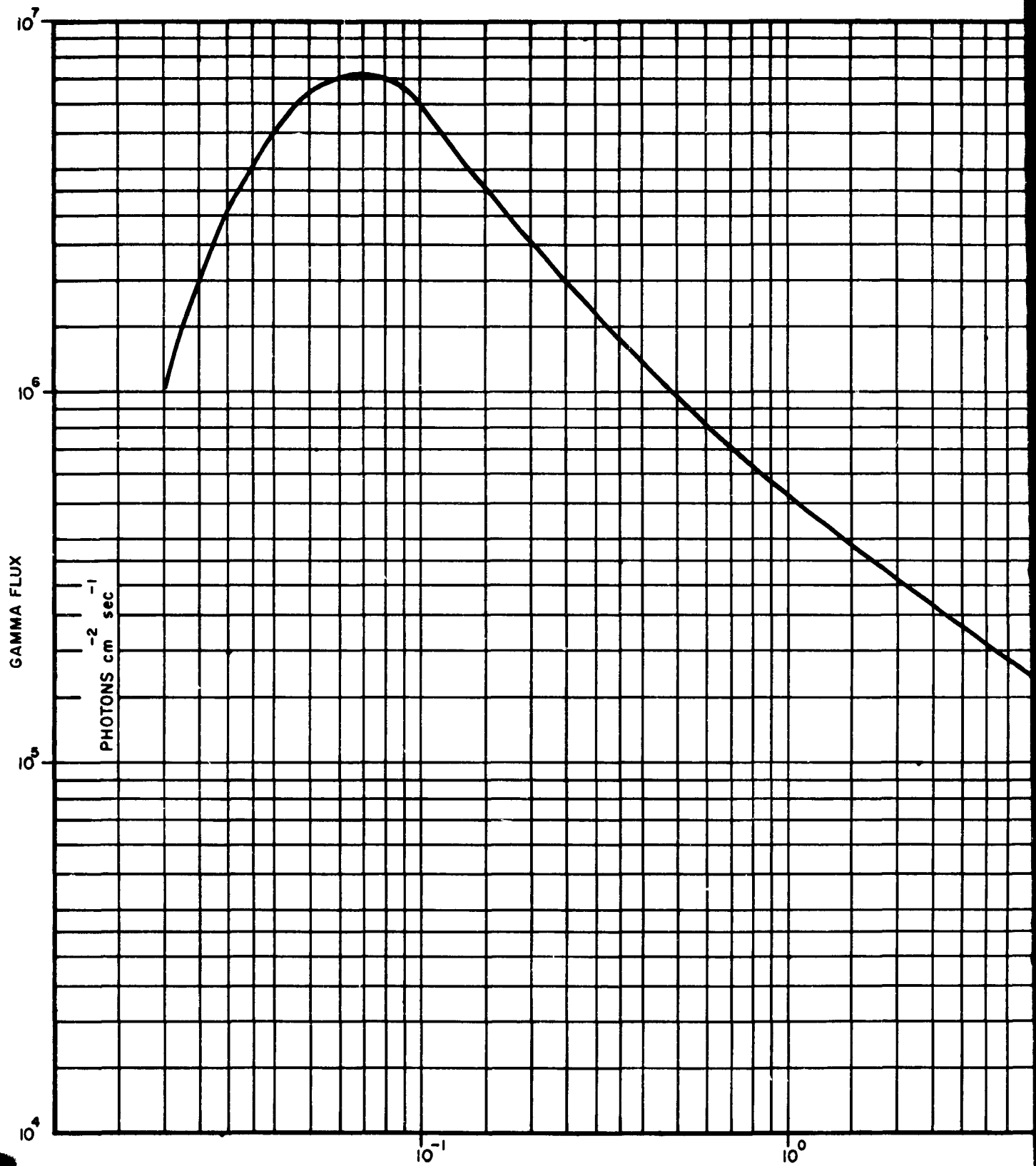

GAMMA ENERGY, ME
 Graph IX. Gamma flux vs. energy at const

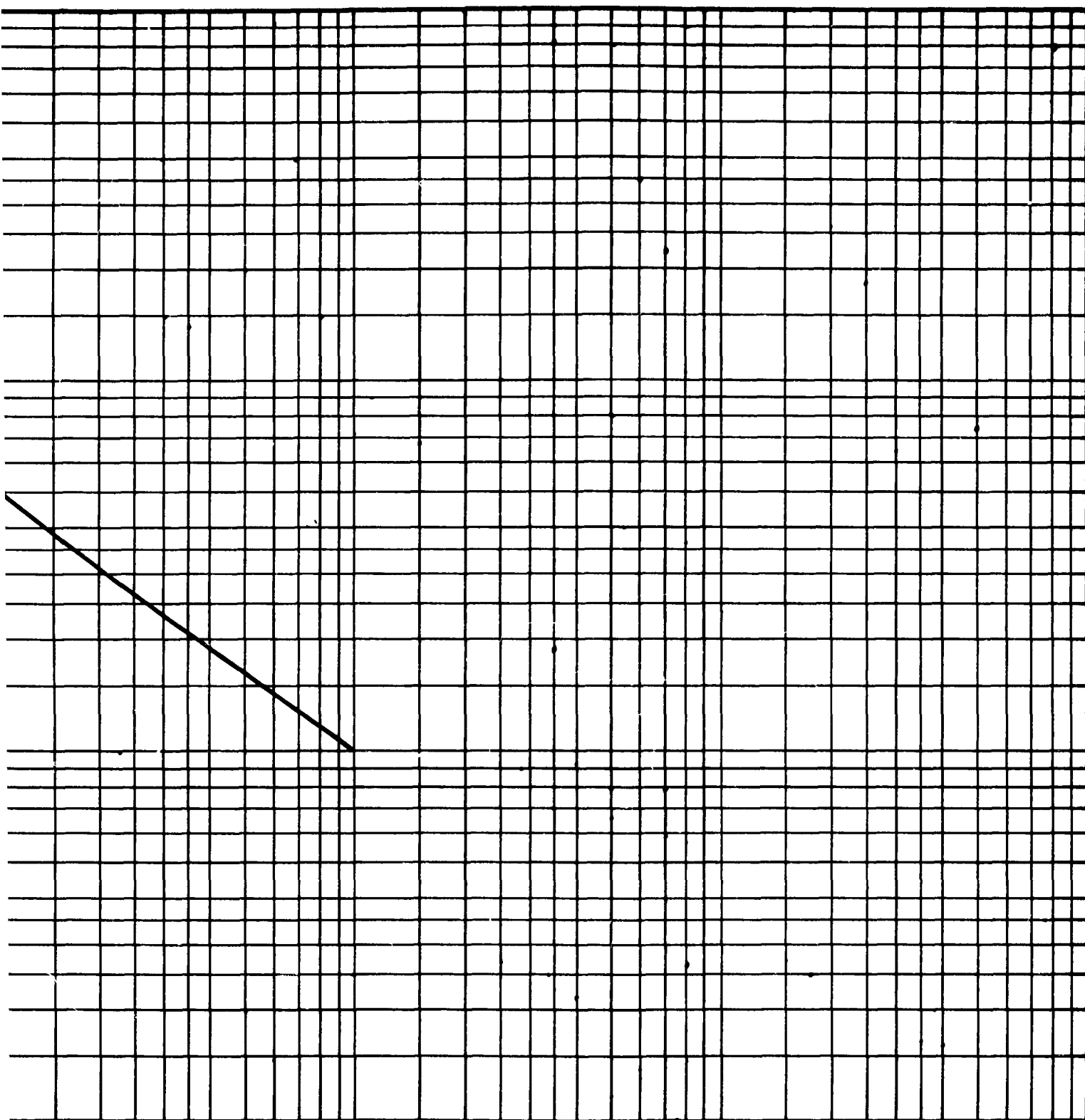

10¹

GAMMA ENERGY, MEV

ux vs. energy at constant field strength, viz. 1 R/hr



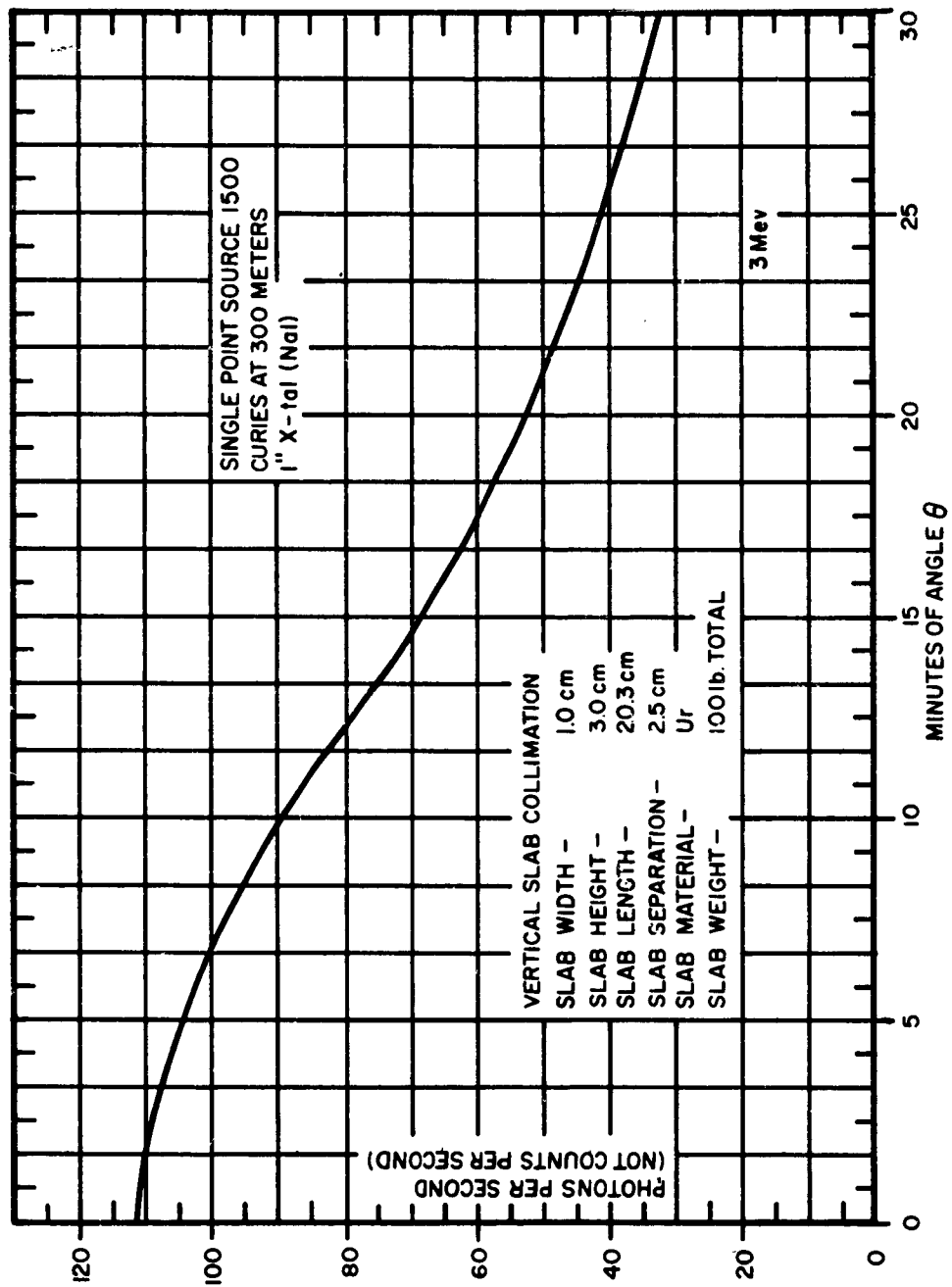

Graph X. Typical angle resolution curve

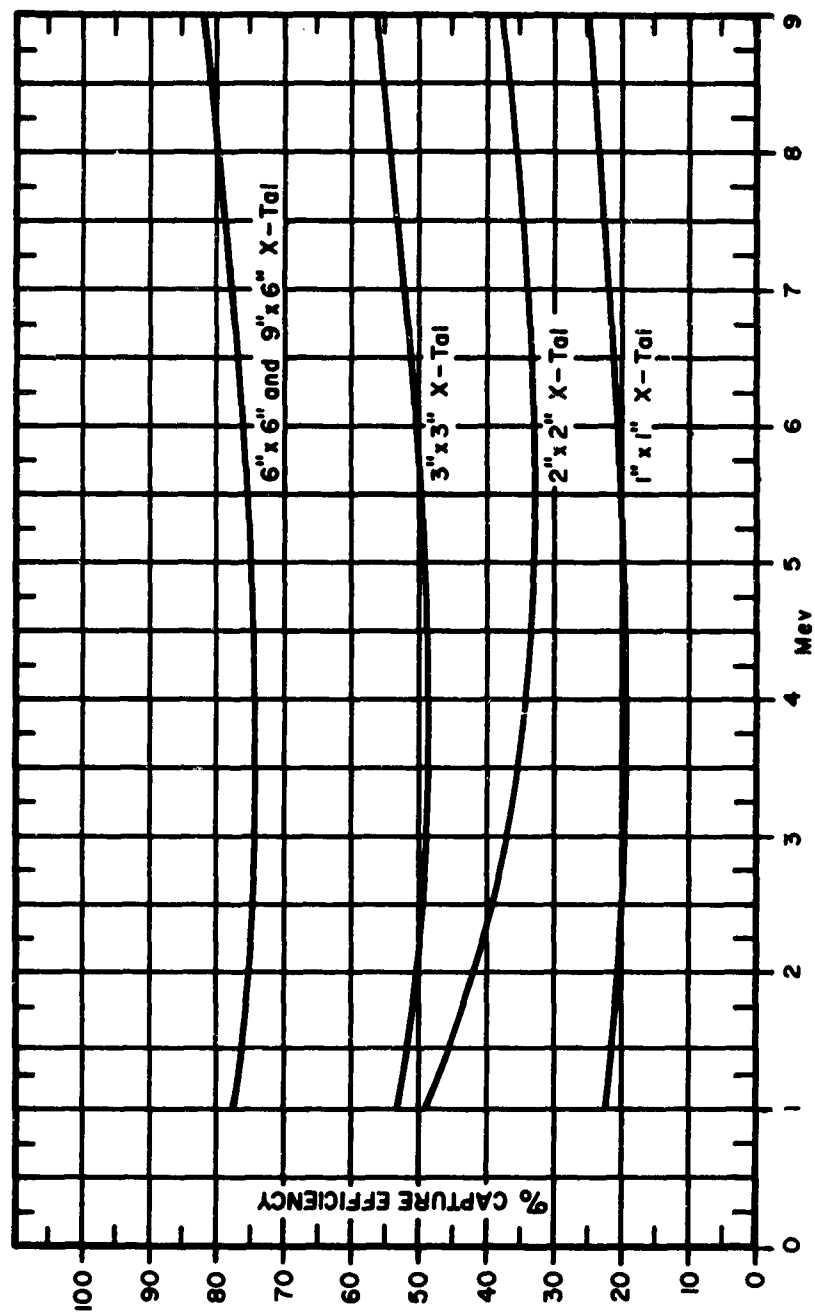

Graph XI. NaI (Tl) crystal capture efficiency (expressed in %)

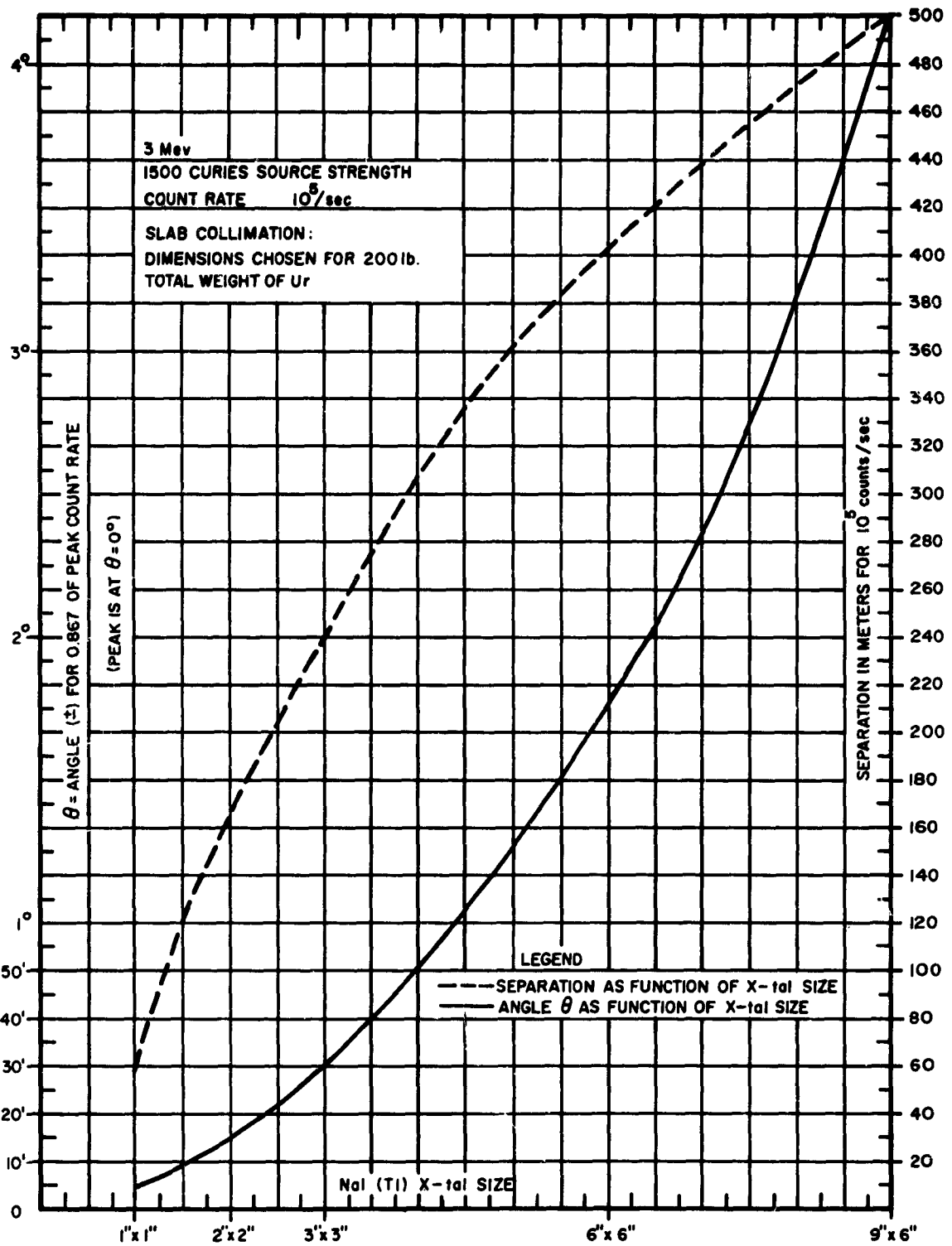

Graph XII. Angular resolution and fixed site location as functions of NaI (Tl) crystal size

REFERENCES

1. Copeland, D. E., and Benjamin, E. W., Pinhole Camera for Gamma-Ray Sources. Nucleonics, August 1949
2. Cohen, A. E., Gamma-Ray Pinhole Television Camera, The Review of Scientific Instruments, January 1960
3. Evans, The Atomic Nucleus, Chapter 23. McGraw Hill.

DISTRIBUTION

No. cys

HEADQUARTERS USAF

1 Hq USAF (AFCOA), Wash 25, DC
 1 Hq USAF (AFOCE), Wash 25, DC
 1 Hq USAF (AFORQ), Wash 25, DC
 1 Hq USAF (AFTAC), Wash 25, DC
 1 USAF Dep, The Inspector General (AFIDI), Norton AFB, Calif
 1 USAF Directorate of Nuclear Safety (AFINS), Kirtland AFB, NM
 1 AFOAR, Bldg T-D, Wash 25, DC

MAJOR AIR COMMANDS

1 AFSC (SCT), Andrews AFB, Wash 25, DC
 2 AFLC (MCSWT), Wright-Patterson AFB, Ohio
 1 ADC (Ops Anlys), Ent AFB, Colorado Springs, Colo
 1 ATC (ATTWS), Randolph AFB, Tex
 1 AUL, Maxwell AFB, Ala
 1 USAFIT (USAF Institute of Technology), Wright-Patterson AFB, Ohio
 1 USAFA, United States Air Force Academy, Colo

AFSC ORGANIZATIONS

1 FTD (Library), Wright-Patterson AFB, Ohio
 1 ASD (ASAPRL), Wright-Patterson AFB, Ohio
 1 AFSC Liaison Office, Naval Msl Astronautics Center, Point Mugu, Calif
 1 (Capt Sidney Goren, USN)
 SSD (SSZMS, Lt Col Austin), AF Unit Post Office, Los Angeles, Calif
 1 ESD (ESAT), Hanscom Fld, Bedford, Mass
 1 AF Msl Dev Cen (RRRT), Holloman AFB, NM
 1 AFFTC (FTFT), Edwards AFB, Calif
 AFMTC, Patrick AFB, Fla
 1 (MU-135, Tech Library)
 1 (Maj J. Rawers)
 1 APGC (PGAPI), Eglin AFB, Fla

DISTRIBUTION (cont'd)

No. cys

1 RADC (Document Library), Griffiss AFB, NY
 1 AEDC (AEOI), Arnold Air Force Station, Tenn

KIRTLAND AFB ORGANIZATIONS

AFSWC, Kirtland AFB, NM
 1 (SWEH)
 50 (SWOI)
 2 (SWVP)
 2 (SWVSE)
 1 ATC Res Rep (SWN), AFSWC, Kirtland AFB, NM
 1 AFLC, Albuquerque Ln Ofc (MCSWQ), AFSWC, Kirtland AFB, NM
 1 US Naval Weapons Evaluation Facility (NWEF) (Code 404),
 Kirtland AFB, NM

OTHER AIR FORCE AGENCIES

1 Lowry Tech Tng Cen (Dept of Wpns Tng), Lowry AFB, Colo
 Director, USAF Project RAND, via: Air Force Liaison Office,
 The RAND Corporation, 1700 Main Street, Santa Monica, Calif
 1 (RAND Physics Div)
 1 (RAND Library)
 1 SAAMA (SAW), Directorate of Special Weapons, Kelly AFB, Tex
 2705 Airmunitions Wing, Hill AFB, Utah
 1 (OOYS)
 1 (OOYD)
 1 Medical Service School, (Radiobiology Br), USAF (ATC),
 Gunter AFB, Ala

ARMY ACTIVITIES

1 Director, Walter Reed Army Institute of Research, Walter Reed
 Medical Center, Wash 12, DC
 1 Commanding Officer, Chemical Warfare Laboratories (Library)
 Army Chemical Center, Md
 1 Army Ordnance Liaison Officer, P. O. Box 5100, Sandia Base, NM
 1 Research Analysis Corp., (Document Control Office), 6935
 Arlington Road, Bethesda, Md., Wash 14, DC

DISTRIBUTION (cont'd)

No. cys

- 1 Office of the Chief, Corps of Engineers, US Army (Protective Construction Branch), Wash 25, DC
- 1 Director, Army Research Office, Arlington Hall Sta, Arlington, Va
- 1 Commanding Officer, US Army Engineers, Research & Development Laboratories, ATTN: Mr. Oglesby, Ft Belvoir, Va

NAVY ACTIVITIES

- 1 Chief of Naval Research, Department of the Navy, Wash 25, DC
- 1 Commanding Officer, Naval Radiological Defense Laboratory (Technical Info Div), San Francisco 24, Calif
- 1 Commanding Officer, US Naval Damage Control Training Center (ABC Defense Course), Naval Base, Philadelphia 12, Pa
- 1 Commander, Naval Ordnance Laboratory, White Oak, Silver Spring, Md
- 1 Commanding Officer, US Naval Explosive Ordnance Disposal Facility, US Naval Propellant Plant, Indian Head, Md

OTHER DOD ACTIVITIES

- 1 Chief, Defense Atomic Support Agency (Document Library), Wash 25, DC
- 1 Commander, Field Command, Defense Atomic Support Agency (FCAG3, Special Weapons Publication Distribution), Sandia Base, NM
- 1 Chairman, Armed Services Explosives Safety Board, Wash 25, DC
- 20 ASTIA (TIPDR), Arlington Hall Sta, Arlington 12, Va

AEC ACTIVITIES

- 1 US Atomic Energy Commission (Headquarters Library), Wash 25, DC
- US Atomic Energy Commission, Div. of Reactor Development, Wash 25, DC
- 1 (Lt Col W. K. Kern)
- 1 (Mr. S. G. Nordlinger)
- 1 (Capt Tardiff)
- 1 Chief, Division of Technical Information Extension, US Atomic Energy Commission, Box 62, Oak Ridge, Tenn

DISTRIBUTION (cont'd)

No. cys

1 University of California Lawrence Radiation Laboratory
(Technical Information Division), P.O. Box 808, Livermore,
Calif

1 University of California Lawrence Radiation Laboratory,
(Technical Info Div., ATTN: Dr. R. K. Wakerling), Berkeley 4,
Calif

1 Director, Los Alamos Scientific Laboratory (Helen Redman,
Report Library), P. O. Box 1663, Los Alamos, NM

1 Brookhaven National Laboratory, Upton, Long Island, NY

2 Argonne National Laboratory (Tech Library), Argonne, Ill

1 Oak Ridge National Laboratory (Tech Library), Oak Ridge, Tenn

1 Manager, Albuquerque Operations Office, US Atomic Energy
Commission, ATTN: Mr. Jack F. Cully, P. O. Box 5400,
Albuquerque, NM

1 US Atomic Energy Commission, Chicago Operations Office,
9800 South Cass Avenue, Argonne, Ill

1 Lewis Research Center, Space Nuclear Propulsion Office,
ATTN: L. C. Corrington, 21000 Brookpark Road, Cleveland 35,
Ohio

1 US Atomic Energy Commission, Idaho Operations Office,
ATTN: A. Wendell Holmes, P. O. Box 1221, Idaho Falls, Idaho

1 US Atomic Energy Commission, New York Operations Office,
376 Hudson Street, New York 14, NY

1 US Atomic Energy Commission, San Francisco Operations
Office, 2111 Bancroft Way, Berkely 4, Calif

OTHER

1 Administrator, National Aeronautics and Space Administration,
400 Maryland Ave., SW, Wash 25, DC

1 Administrator, National Aeronautics and Space Administration,
ATTN: Mr. Larry Early, Wallops Island, Va

5 Franklin Systems, Inc., 2734 Hillsboro Road, West Palm Beach,
Fla

1 Central Intelligence Agency (OCR/LY/ILS), Wash 25, DC

1 Institute for Defense Analysis, Room 2B257, The Pentagon,
Wash 25, DC

1 Official Record Copy (SWVSE, Capt C. C. Vogler)

<p>Air Force Special Weapons Center, Kirtland AF Base, New Mexico Rot No. AFSWC-TDR-63-28. INVESTIGATION, CONCEPTUAL DESIGN AND OPERATIONAL USE OF A DIRECTIONAL NUCLEAR RADIATION DETECTOR. Final Report, April 1963. 74 p. incl illus, 3 refs.</p> <p style="text-align: center;">Unclassified Report</p> <p>Several ground-based systems have been shown to be feasible for defining the location, curie strength and energy level of numerous and powerful radioactive, gamma-emitting sources scattered across an area of 1,000 ft. radius. These systems involve use of fixed survey sites, or mobile sites, or a combination thereof. The preferred system would use two fixed and one mobile sites. (Mobile sites are desirable but unessential.)</p> <p style="text-align: center;">○</p>	<p>1. Dosage rates Gamma radiation -- description Radiation detectors -- design Radiation hazards Remote control equipment</p> <p>2. Shielding I. AFSC Project 8171, Task 817102 Contract AF 29(601)- 5405 Franklin Systems, Inc. West Palm Beach, Fla In ASTIA collection</p> <p>III. IV.</p>	<p>Air Force Special Weapons Center, Kirtland AF Base, New Mexico Rot No. AFSWC-TDR-63-28. INVESTIGATION, CONCEPTUAL DESIGN AND OPERATIONAL USE OF A DIRECTIONAL NUCLEAR RADIATION DETECTOR. Final Report, April 1963. 74 p. incl illus, 3 refs.</p> <p style="text-align: center;">Unclassified Report</p> <p>Several ground-based systems have been shown to be feasible for defining the location, curie strength and energy level of numerous and powerful radioactive, gamma-emitting sources scattered across an area of 1,000 ft. radius. These systems involve use of fixed survey sites, or mobile sites, or a combination thereof. The preferred system would use two fixed and one mobile sites. (Mobile sites are desirable but unessential.)</p> <p style="text-align: center;">○</p>	<p>1. Dosage rates Gamma radiation -- description Radiation detectors -- design Radiation hazards Remote control equipment</p> <p>2. Shielding I. AFSC Project 8171, Task 817102 Contract AF 29(601)- 5405 Franklin Systems, Inc. West Palm Beach, Fla In ASTIA collection</p> <p>III. IV.</p>
<p>Air Force Special Weapons Center, Kirtland AF Base, New Mexico Rot No. AFSWC-TDR-63-28. INVESTIGATION, CONCEPTUAL DESIGN AND OPERATIONAL USE OF A DIRECTIONAL NUCLEAR RADIATION DETECTOR. Final Report, April 1963. 74 p. incl illus, 3 refs.</p> <p style="text-align: center;">Unclassified Report</p> <p>Several ground-based systems have been shown to be feasible for defining the location, curie strength and energy level of numerous and powerful radioactive, gamma-emitting sources scattered across an area of 1,000 ft. radius. These systems involve use of fixed survey sites, or mobile sites, or a combination thereof. The preferred system would use two fixed and one mobile sites. (Mobile sites are desirable but unessential.)</p> <p style="text-align: center;">○</p>	<p>1. Dosage rates Gamma radiation -- description Radiation detectors -- design Radiation hazards Remote control equipment</p> <p>2. Shielding I. AFSC Project 8171, Task 817102 Contract AF 29(601)- 5405 Franklin Systems, Inc. West Palm Beach, Fla In ASTIA collection</p> <p>III. IV.</p>	<p>Air Force Special Weapons Center, Kirtland AF Base, New Mexico Rot No. AFSWC-TDR-63-28. INVESTIGATION, CONCEPTUAL DESIGN AND OPERATIONAL USE OF A DIRECTIONAL NUCLEAR RADIATION DETECTOR. Final Report, April 1963. 74 p. incl illus, 3 refs.</p> <p style="text-align: center;">Unclassified Report</p> <p>Several ground-based systems have been shown to be feasible for defining the location, curie strength and energy level of numerous and powerful radioactive, gamma-emitting sources scattered across an area of 1,000 ft. radius. These systems involve use of fixed survey sites, or mobile sites, or a combination thereof. The preferred system would use two fixed and one mobile sites. (Mobile sites are desirable but unessential.)</p> <p style="text-align: center;">○</p>	<p>1. Dosage rates Gamma radiation -- description Radiation detectors -- design Radiation hazards Remote control equipment</p> <p>2. Shielding I. AFSC Project 8171, Task 817102 Contract AF 29(601)- 5405 Franklin Systems, Inc. West Palm Beach, Fla In ASTIA collection</p> <p>III. IV.</p>

<p>Primary study considerations have involved accuracy of source location, radiation hazards to crew personnel, optimum means of source collimation, flexibility to adapt to various problem situations, and adaptability to use of certain 2nd - 3rd generation aids involving airborne facilities and superimposed visual displays. All are important, and are discussed. Radioactive background, detector shielding, and some equipment design factors are reported upon. Opportunities and advantages for closely relating survey and decontamination operations are explained, and such a composite endeavor is recommended.</p> <p style="text-align: center;">○</p>	<p>Primary study considerations have involved accuracy of source location, radiation hazards to crew personnel, optimum means of source collimation, flexibility to adapt to various problem situations, and adaptability to use of certain 2nd - 3rd generation aids involving airborne facilities and superimposed visual displays. All are important, and are discussed. Radioactive background, detector shielding, and some equipment design factors are reported upon. Opportunities and advantages for closely relating survey and decontamination operations are explained, and such a composite endeavor is recommended.</p> <p style="text-align: center;">○</p>	
<p>Primary study considerations have involved accuracy of source location, radiation hazards to crew personnel, optimum means of source collimation, flexibility to adapt to various problem situations, and adaptability to use of certain 2nd - 3rd generation aids involving airborne facilities and superimposed visual displays. All are important, and are discussed. Radioactive background, detector shielding, and some equipment design factors are reported upon. Opportunities and advantages for closely relating survey and decontamination operations are explained, and such a composite endeavor is recommended.</p> <p style="text-align: center;">○</p>	<p>Primary study considerations have involved accuracy of source location, radiation hazards to crew personnel, optimum means of source collimation, flexibility to adapt to various problem situations, and adaptability to use of certain 2nd - 3rd generation aids involving airborne facilities and superimposed visual displays. All are important, and are discussed. Radioactive background, detector shielding, and some equipment design factors are reported upon. Opportunities and advantages for closely relating survey and decontamination operations are explained, and such a composite endeavor is recommended.</p> <p style="text-align: center;">○</p>	