

UNCLASSIFIED

AD **405 728**

DEFENSE DOCUMENTATION CENTER

FOR

SCIENTIFIC AND TECHNICAL INFORMATION

CAMERON STATION, ALEXANDRIA, VIRGINIA



UNCLASSIFIED

NOTICE: When government or other drawings, specifications or other data are used for any purpose other than in connection with a definitely related government procurement operation, the U. S. Government thereby incurs no responsibility, nor any obligation whatsoever; and the fact that the Government may have formulated, furnished, or in any way supplied the said drawings, specifications, or other data is not to be regarded by implication or otherwise as in any manner licensing the holder or any other person or corporation, or conveying any rights or permission to manufacture, use or sell any patented invention that may in any way be related thereto.

6335

405728

405728

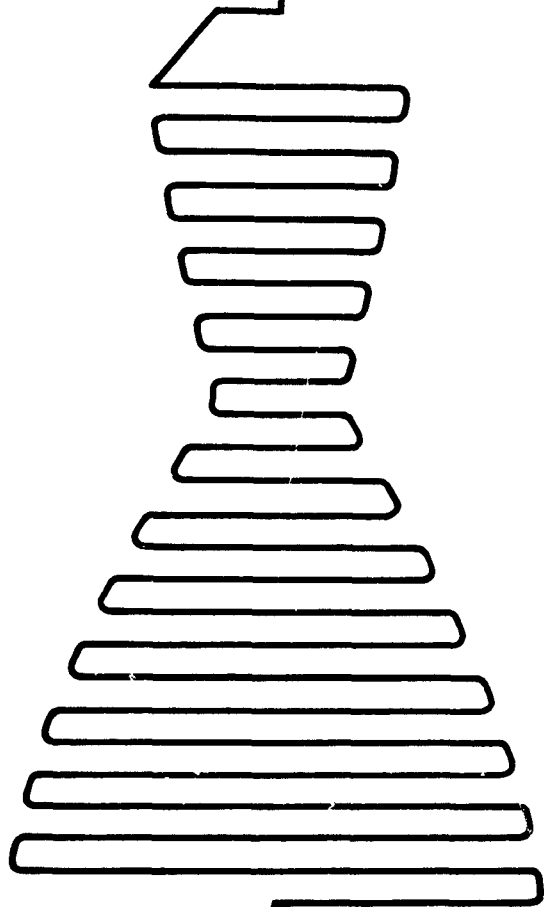

DDC
RECEIVED
JUN 6 1963
TISA B



ROCKETDYNE

A DIVISION OF NORTH AMERICAN AVIATION, INC.

CANOGA PARK, CALIFORNIA

(4) NA
(5)

R-3994

17

ELECTROINTERFERENCE EVALUATION
OF THE ATLAS MA-5
ELECTRICAL SYSTEM

ROCKETDYNE

A DIVISION OF NORTH AMERICAN AVIATION, INC.

6633 CANOGA AVENUE
CANOGA PARK, CALIFORNIA

Contract AF04(694)-135
Part I, Item 1,
as Amended by
Request for Service Order 135-62-4

PREPARED BY

Rocketdyne Engineering
Canoga Park, California

APPROVED BY

J. J. Griffin / JJK
J.J. Griffin
Atlas/Thor/Jupiter
Program Manager

NO. OF PAGES 81 & ix

REVISIONS

DATE 15 May 1963

DATE	REV. BY	PAGES AFFECTED	REMARKS

FOREWORD

This report was prepared under G.O. 8333 in compliance with Contract AF04(694)-135, Part I, Item 1, as amended by Request for Service Order 135-62-4. Testing was conducted in accordance with Space Technologies Laboratories, Inc. (STL) document No. 6201-0004-NU-000, entitled "Electro-Interference Control Specification for Nike Zeus Target Program (Atlas Group A Missile Systems)."

ABSTRACT

The results of radio noise tests performed on the Atlas MA-5 electrical system are presented. Conducted interference measurements using a stabilization network were made from 150 kilocycles to 25 megacycles. Conducted interference measurements using a current probe were made from 30 cps to 25 megacycles. Radiated interference measurements were made in the frequency range of 15 kilocycles to 400 megacycles. The MA-5 engine electrical system is within specification limits between 30 and 15 kilocycles in the conducted interference portion of the test. In other portions of the test, the interference levels measured varied, with the majority of the measurements above specified limits.

CONTENTS

Foreword	iii
Abstract	iii
Summary and Conclusions	1
Introduction	3
Discussion	5
History	5
Testing	6
<u>Appendix A</u>	11
Test Engine Equipment	11
<u>Appendix B</u>	13
Conducted Interference Using Line-Stabilization Network	13
<u>Appendix C</u>	23
Conducted Interference Using Current Probe	23
<u>Appendix D</u>	73
Radiated Interference Measurements	73

ILLUSTRATIONS

1. Test Switching Circuits	7
2. Circuitry Used to Switch Relay Box	8
3. Atlas MA-5 Electrointerference Test Setup	10
4. Switching Function 1 of Conducted Interference Line Stabilization Network	14
5. Switching Function 2 of Conducted Interference Line Stabilization Network	15
6. Switching Function 3 of Conducted Interference Line Stabilization Network	16
7. Switching Function 4 of Conducted Interference Line Stabilization Network	17
8. Switching Function 6 of Conducted Interference Line Stabilization Network	18
9. Switching Function 7 of Conducted Interference Line Stabilization Network	19
10. Switching Function 9 of Conducted Interference Line Stabilization Network	20
11. Switching Function 10 of Conducted Interference Line Stabilization Network	21
12. Line A, Switching Function 6 of Conducted Interference Current Probe	28
13. Line A, Switching Function 7 of Conducted Interference Current Probe	29
14. Line A, Switching Function 9 of Conducted Interference Current Probe	30
15. Line A, Switching Function 10 of Conducted Interference Current Probe	31

ROCKETDYNE
A DIVISION OF NORTH AMERICAN AVIATION, INC.

16.	Line B, Switching Function 1 of Conducted	
	Interference Current Probe	32
17.	Line B, Switching Function 2 of Conducted	
	Interference Current Probe	33
18.	Line B, Switching Function 4 of Conducted	
	Interference Current Probe	34
19.	Line B, Switching Function 6 of Conducted	
	Interference Current Probe	35
20.	Line C, Switching Function 2 of Conducted	
	Interference Current Probe	36
21.	Line D, Switching Function 4 of Conducted	
	Interference Current Probe	37
22.	Line E, Switching Function 3 of Conducted	
	Interference Current Probe	38
23.	Line F, Switching Function 3 of Conducted	
	Interference Current Probe	39
24.	Line G, Switching Function 1 of Conducted	
	Interference Current Probe	40
25.	Line H, Switching Function 7 of Conducted	
	Interference Current Probe	41
26.	Line I, Switching Function 9 of Conducted	
	Interference Current Probe	42
27.	Line J, Switching Function 10 of Conducted	
	Interference Current Probe	43
28.	Line K, Switching Function 2 of Conducted	
	Interference Current Probe	44
29.	Line K, Switching Function 10 of Conducted	
	Interference Current Probe	45
30.	Line L, Switching Function 2 of Conducted	
	Interference Current Probe	46

ROCKETDYNE
A DIVISION OF NORTH AMERICAN AVIATION, INC.

31.	Line L, Switching Function 10 of Conducted Interference Current Probe	47
32.	Line M, Switching Function 3 of Conducted Interference Current Probe	48
33.	Line M, Switching Function 7 of Conducted Interference Current Probe	49
34.	Line N, Switching Function 3 of Conducted Interference Current Probe	50
35.	Line N, Switching Function 7 of Conducted Interference Current Probe	51
36.	Line O, Switching Function 4 of Conducted Interference Current Probe	52
37.	Line O, Switching Function 7 of Conducted Interference Current Probe	53
38.	Line P, Switching Function 4 of Conducted Interference Current Probe	54
39.	Line P, Switching Function 7 of Conducted Interference Current Probe	55
40.	Line Q, Switching Function 3 of Conducted Interference Current Probe	56
41.	Line Q, Switching Function 9 of Conducted Interference Current Probe	57
42.	Line R, Switching Function 3 of Conducted Interference Current Probe	58
43.	Line R, Switching Function 4 of Conducted Interference Current Probe	59
44.	Line R, Switching Function 9 of Conducted Interference Current Probe	60
45.	Line S, Switching Function 4 of Conducted Interference Current Probe	61
46.	Line S, Switching Function 9 of Conducted Interference Current Probe	62

ROCKETDYNE
A DIVISION OF NORTH AMERICAN AVIATION, INC.

47.	Line T, Switching Function 1 of Conducted Interference Current Probe	63
48.	Line T, Switching Function 6 of Conducted Interference Current Probe	64
49.	Line U, Switching Function 1 of Conducted Interference Current Probe	65
50.	Line U, Switching Function 6 of Conducted Interference Current Probe	66
51.	Line V, Switching Function 10 of Conducted Interference Current Probe	67
52.	Line W, Switching Function 7 of Conducted Interference Current Probe	68
53.	Line X, Switching Function 9 of Conducted Interference Current Probe	69
54.	Line Y, Switching Function 4 of Conducted Interference Current Probe	70
55.	Line Y, Switching Function 7 of Conducted Interference Current Probe	71
56.	Line Z, Switching Function 4 of Conducted Interference Current Probe	72
57.	Switching Function 1 of Radiated Interference	74
58.	Switching Function 2 of Radiated Interference	75
59.	Switching Function 3 of Radiated Interference	76
60.	Switching Function 4 of Radiated Interference	77
61.	Switching Function 6 of Radiated Interference	78
62.	Switching Function 7 of Radiated Interference	79
63.	Switching Function 9 of Radiated Interference	80
64.	Switching Function 10 of Radiated Interference	81

TABLES

1. Switching Function	4
2. Conducted Interference Test Using Stabilization Network	13
3. Conducted Interference Test Using Current Probe (Specification Limit = 120 Decibels)	24
4. Conducted Interference Test Using Current Probe	25
5. Radiated Interference Measurements	73

SUMMARY AND CONCLUSIONS

All interference measured during the test was classified as broadband impulse type.

The switching circuit used during the test is similar to the actual control circuit used in the Atlas autopilot programmer. It was necessary to actuate and deactuate continuously the circuits being tested to perform the broadband aural (slideback) measurements. The circuit used is shown in Fig. 1 and an explanation of its operation is presented in the Discussion section. In this report, each sequence operation is assigned a switching function number as indicated in Table 1.

Conducted interference measurements using a stabilization network were made from 150 kilocycles to 25 megacycles. A tabular summary of the results, and graphs illustrating the various interference levels measured are presented in Appendix A. All switching functions were above the specification limits throughout the frequency spectrum with the exception of the energizing of the vernier lockin relay (switching function 2) and the energizing of the ignition relays (switching function 3). Switching function 2 is within specification limits only at 24 megacycles, and switching function 3 is within specification limits at the 14 megacycles and 24 megacycles frequency ranges.

Conducted interference measurements using a current probe were made from 30 cps to 25 megacycles. A tabular summary of the results, and graphs illustrating the various interference levels measured are presented in Appendix B. All switching functions were well within the specification limits in the frequency range from 30 cps to 15 kilocycles. The interference levels measured in the frequency range from 15 kilocycles to 25 megacycles varied greatly, with a majority of the levels above the specification limits. The results can be analyzed best by referring to Fig. 4 through 11.

ROCKETDYNE
A DIVISION OF NORTH AMERICAN AVIATION, INC.

Radiated interference measurements were made in the frequency range of 15 kilocycles to 400 megacycles. Interference levels measured within this range were above the specification limits. The results are presented in Appendix C.

The MA-5 engine electrical system is within specification limits between 30 and 15 kilocycles in the conducted interference portion of the test using the current probe. In the other portions of the test, the interference levels measured varied with the majority of the measurements above specified limits. This is indicated in Appendix A through D.

Considerable shielding of cabling will be needed to reduce the interference within specification limits. The present filtering on the MA-5 engine electrical system may also have to be redesigned to reduce the interference.

INTRODUCTION

The Aerospace Nike Zeus Target Program personnel requested a radio frequency interference (RFI) spectrum signature of the MA-5 engine electrical system. No prior information on the RFI aspects of the MA-5 electrical system existed at the time of the request.

Some RFI data were available for the MA-2 engine electrical system, which is similar to the MA-5 electrical system. The MA-2 data were obtained on a limited-scope program intended to ensure that specially designed filters on the engine solenoids would eliminate interaction between the solenoids and the autopilot programmer.

TABLE 1

SWITCHING FUNCTIONS

	<u>Function</u>	<u>Description</u>
1	Ener. STP	Energize Start Tank Pressure
2	Ener. VLI	Energize Vernier Lockin
3	Ener. IGN	Energize Ignition
4	Ener. FLI	Energize Flight Lockin
5*	De-ener. IGN	De-energize Ignition
6	De-ener. STP	De-energize Start Tank Pressure
7	Ener. BCO	Energize Booster Cutoff
8**	Ener. STP	Energize Start Tank Pressure
9	Ener. SCO	Energize Sustainer Cutoff
10	Ener. VCO	Energize Vernier Cutoff

*Measurement not necessary in Step 5 since no circuitry is involved.

**Measurement not necessary in Step 8 since it is the same as Step 1.

DISCUSSION

An inductive circuit, such as a relay or a solenoid circuit, acts to maintain a current flow. Whenever such a circuit is energized or de-energized, a voltage transient with the relationship $V = -L \frac{di}{dt}$ is produced. As this equation indicates, the amplitude of the wave front depends on the speed of circuit interruption, that is, on the rate of current change, $\frac{di}{dt}$. An attendant RFI may also be produced, its magnitude depending on the steepness of the transient wave front as well as its amplitude.

This type of RFI can be satisfactorily suppressed with a properly designed filter.

HISTORY

When the "square" autopilot programmer was phased into the MA-2 missile, it was found that interaction between it and engine solenoid valve coils caused improper programming operation. An immediate program was undertaken to design filters which would eliminate this interaction. Because of limited time and funds, it was decided not to meet the MIL-I-6181B specification for the system, but only to eliminate the interaction causing the malfunction.

The filters were designed, tested, and incorporated into the MA-2 and MA-3 systems. At a later date they were also incorporated into the MA-5 system.

Because the RFI information obtained for the MA-2 engine system was limited, although applicable by similarity to the MA-5, compliance or lack of compliance with MIL-I-6181D or STL document 6201-0004-NU-000 could not be determined without thorough testing. Tests were, therefore, performed to obtain a laboratory RFI signature for the MA-5 engine electrical system.

TESTING

Program

The three areas considered for the testing of the MA-5 electrical system to determine its electrointerference spectrum signature were:

1. Conducted interference using a stabilization network (paragraph 3.5.1.1.1*)
2. Conducted interference using current probes (paragraph 3.5.1.1.2)
3. Radiated interference (paragraph 3.5.1.2)

The block diagram of the test configuration is presented in Fig. 1 . The switching functions are described in Table 1 . There are 10 switching functions needed to simulate normal engine operation.

The circuitry used to switch the relay box is shown in Fig. 2 . The circuitry was similar to the switching circuitry used in the square autopilot. The operation of the circuit was as follows.

*Paragraphs refer to specification STL document 6201-0004-NU-000.

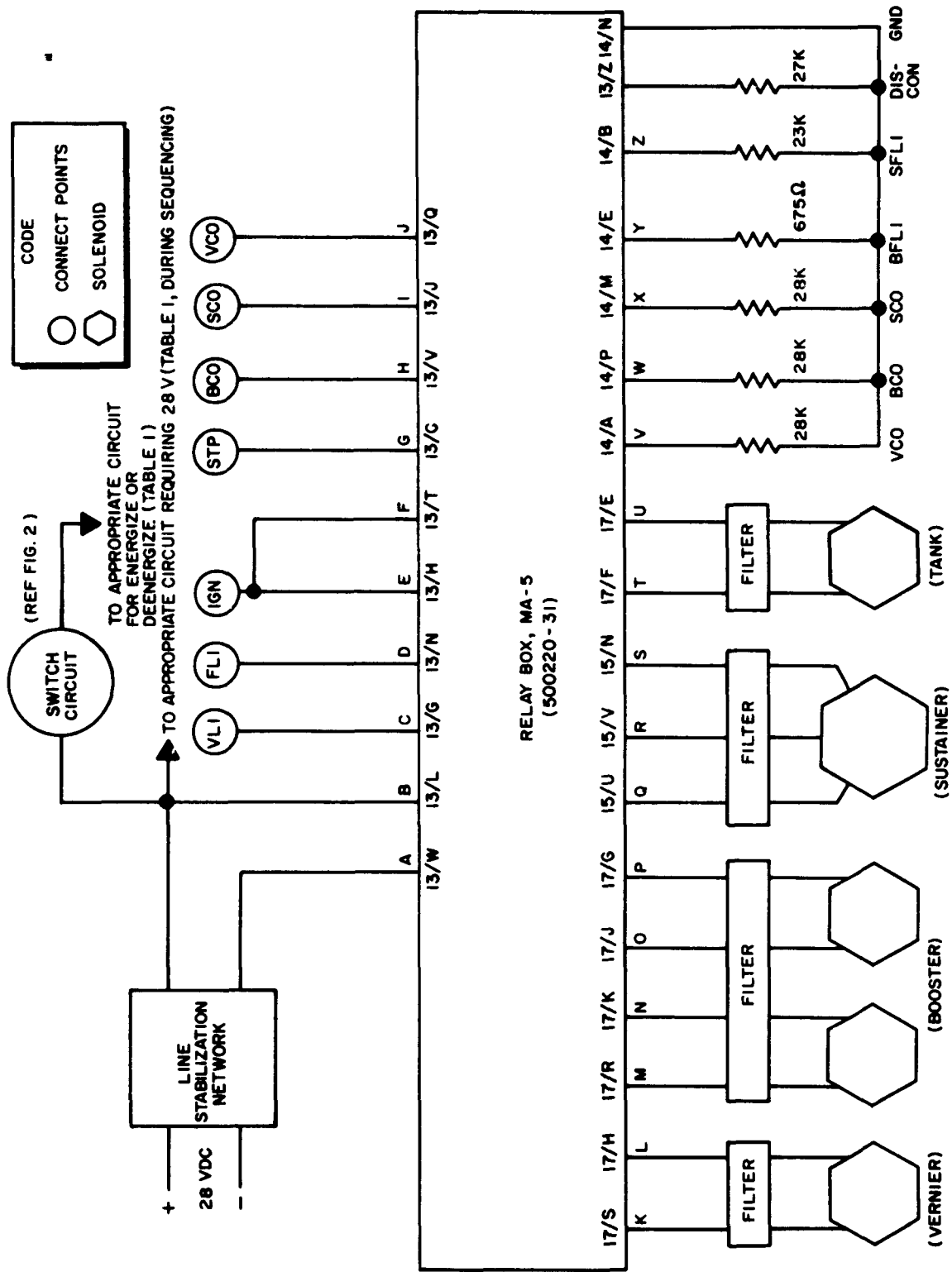

Figure 1. Test Switching Circuits

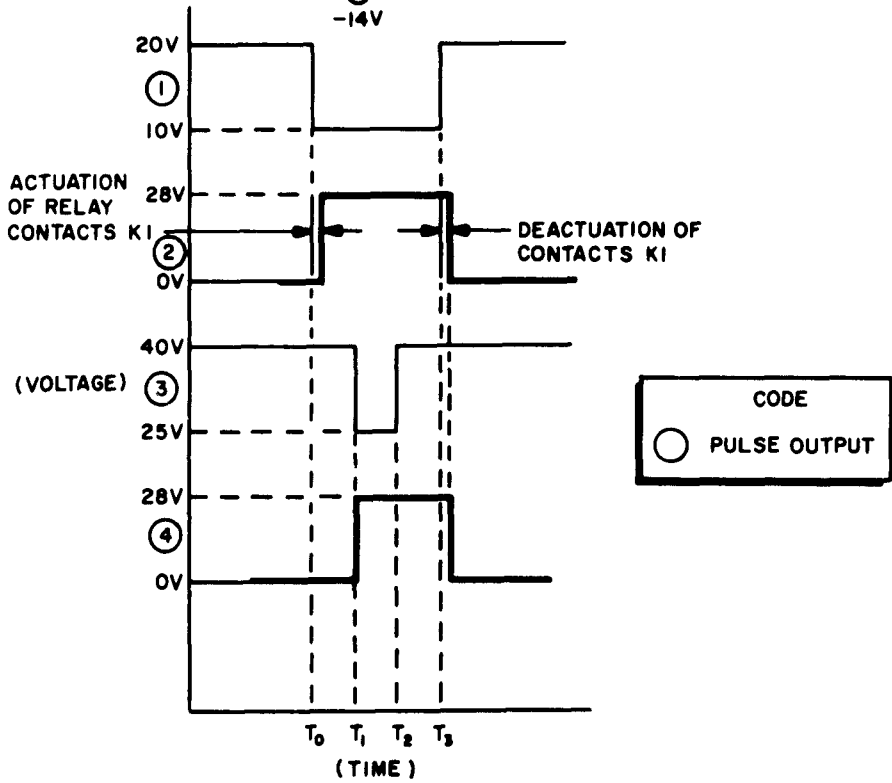
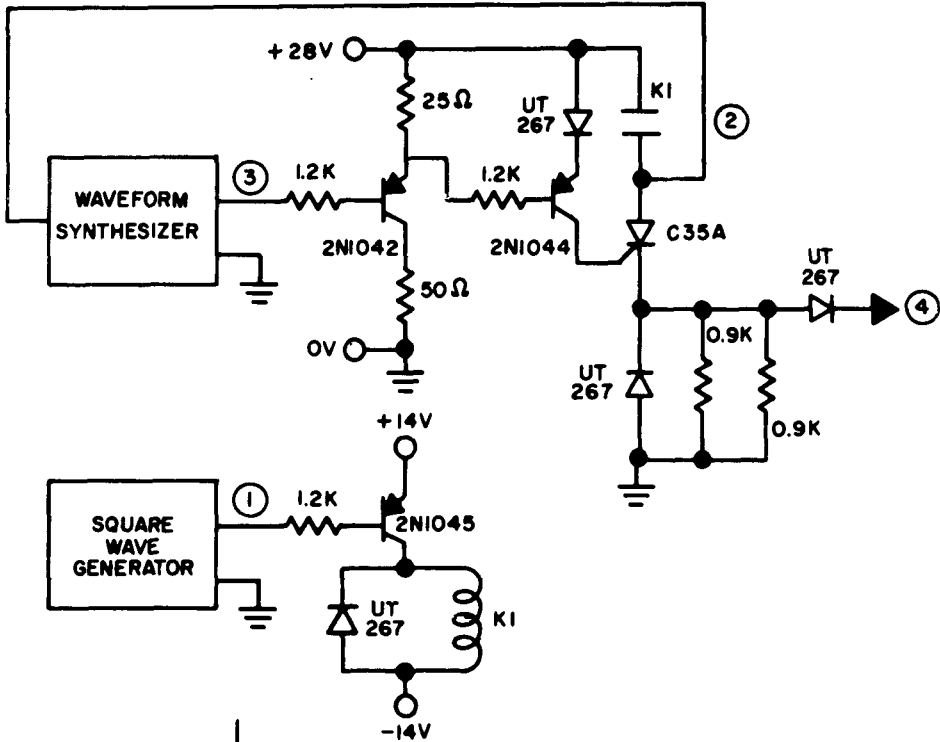

Figure 2. Circuitry Used to Switch Relay Box

The square wave generator provided a square wave at a frequency of 1 cps which served to energize relay K1. The contacts of relay K1 closed a few milliseconds later as indicated in Fig. 2. The delay was due to contact actuation. At the time contacts K1 closed, a synchronizing pulse was sent out to start the wave form synthesizer. The synthesizer provided a signal to trigger the silicon controlled rectifier (SCR C35A) gate at time T_1 , thereby actuating the test circuit. At time T_2 , the gate pulse was removed from the SCR and, at time T_3 plus the deactuation time of the contacts K1, the test circuit is deactuated.

Setup

The test setup is presented in Fig. 3. The test setup was contained within a shielded room, and assembled on a copper ground plane. The test instrumentation was as required in the specification (STL Document 6201-0004-NU-000). The 28 vdc power was connected through a line-stabilization network to a terminal board. Leads connecting to the relay circuits in the MA-5 relay box were also attached to the terminal board. The filters and valves were connected to the appropriate relay box terminals, and resistors were used to simulate telemetry line loads. The switching circuit presented in Fig. 2 was connected to the appropriate lines on the terminal board.

The specific MA-5 engine equipment used for this test is listed in Appendix A.

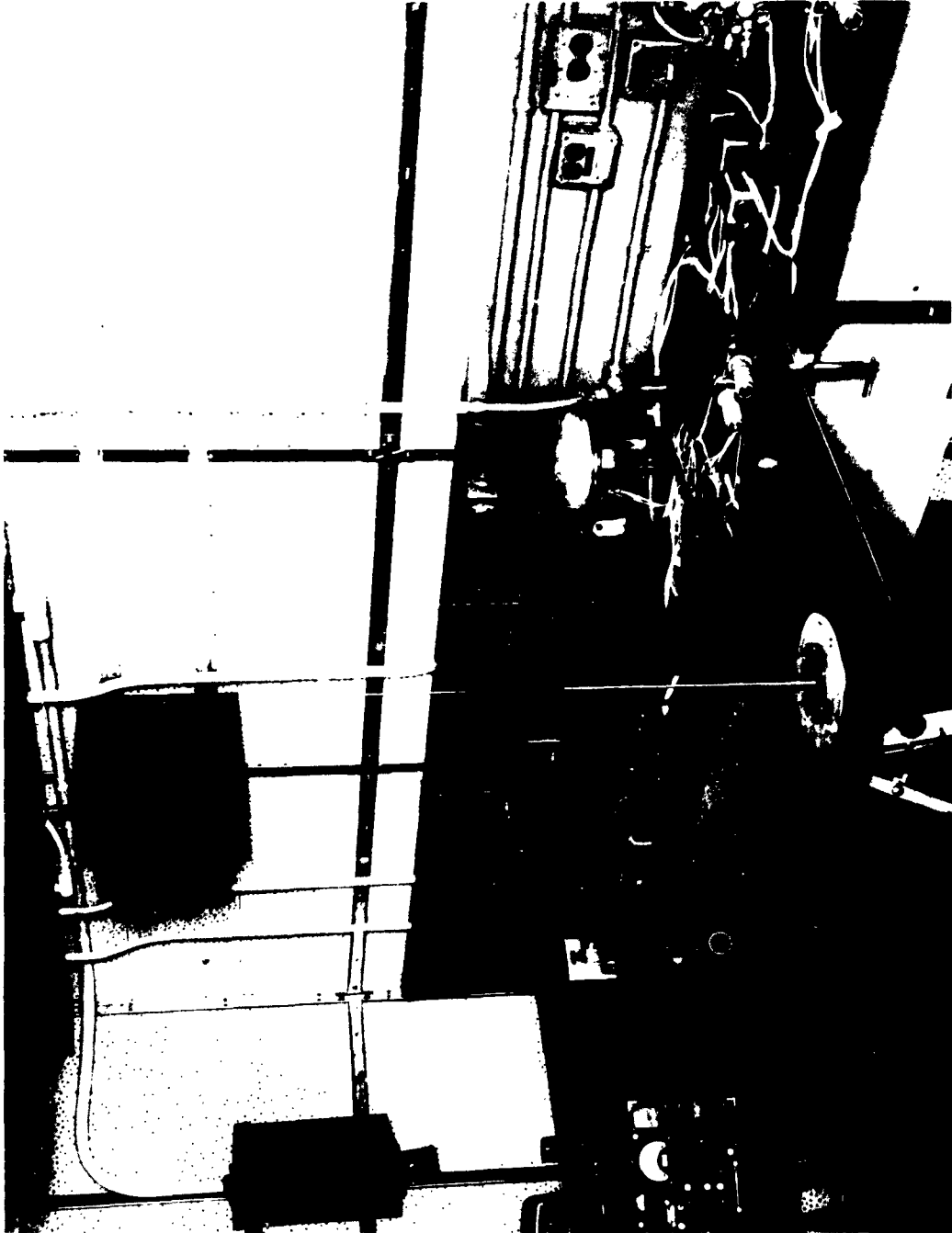

5412-12/28/63-1

Figure 3 Atlas MA-5 Electrointerference Test Setup

APPENDIX A

TEST ENGINE EQUIPMENT

The test setup equipment is:

1. Relay Box, P/N 500220-31, S/N R039
2. Package, Hydraulic (Sustainer Valve), P/N 1359-589435M,
S/N 113
3. Four-Way Solenoid Valve (Vernier Valve), P/N 9512-59090,
S/N P-1144
4. Four-Way Solenoid Valve (Booster Valve), P/N 553319D,
S/N R891V
5. Four-Way Solenoid Valve (Booster Valve), P/N 9512-59090,
S/N R012T
6. Four-Way Solenoid Valve (Tank Valve), P/N 9512-59090,
S/N R022T
7. Filter Assembly, Sustainer, P/N 501429, S/N XR002
8. Filter Assembly, Booster, P/N 501426, S/N XR002
9. Filter Assembly, Valves, P/N 501443B, S/N R070R

APPENDIX B

CONDUCTED INTERFERENCE USING LINE-STABILIZATION NETWORK

Table 2 and Fig. 4 through 11 present conducted interference data using the line-stabilization network (paragraph 3.5.1.1.1 of STL document 6201-0004-NU-000).

TABLE 2

CONDUCTED INTERFERENCE TEST USING STABILIZATION NETWORK*

Frequency, megacycles	Function							
	1	2	3	4	6	7	9	10
0.160	142	140	134	129	104	103	135	133
0.380	138	135	123	119	106	105	124	131
1	130	125	109	111	107	106	123	115
2	134	117	95	106	102	102	110	113
3.5	129	114	95	99	102	94	106	111
7	106	97	67	97	99	83	100	100
14	94	86	33	91	96	89	90	91
24	83	77	-	97	82	87	83	96

*Units given in decibels above 1 microvolt /megacycle at meter input 150 kilocycles to 25 megacycles.

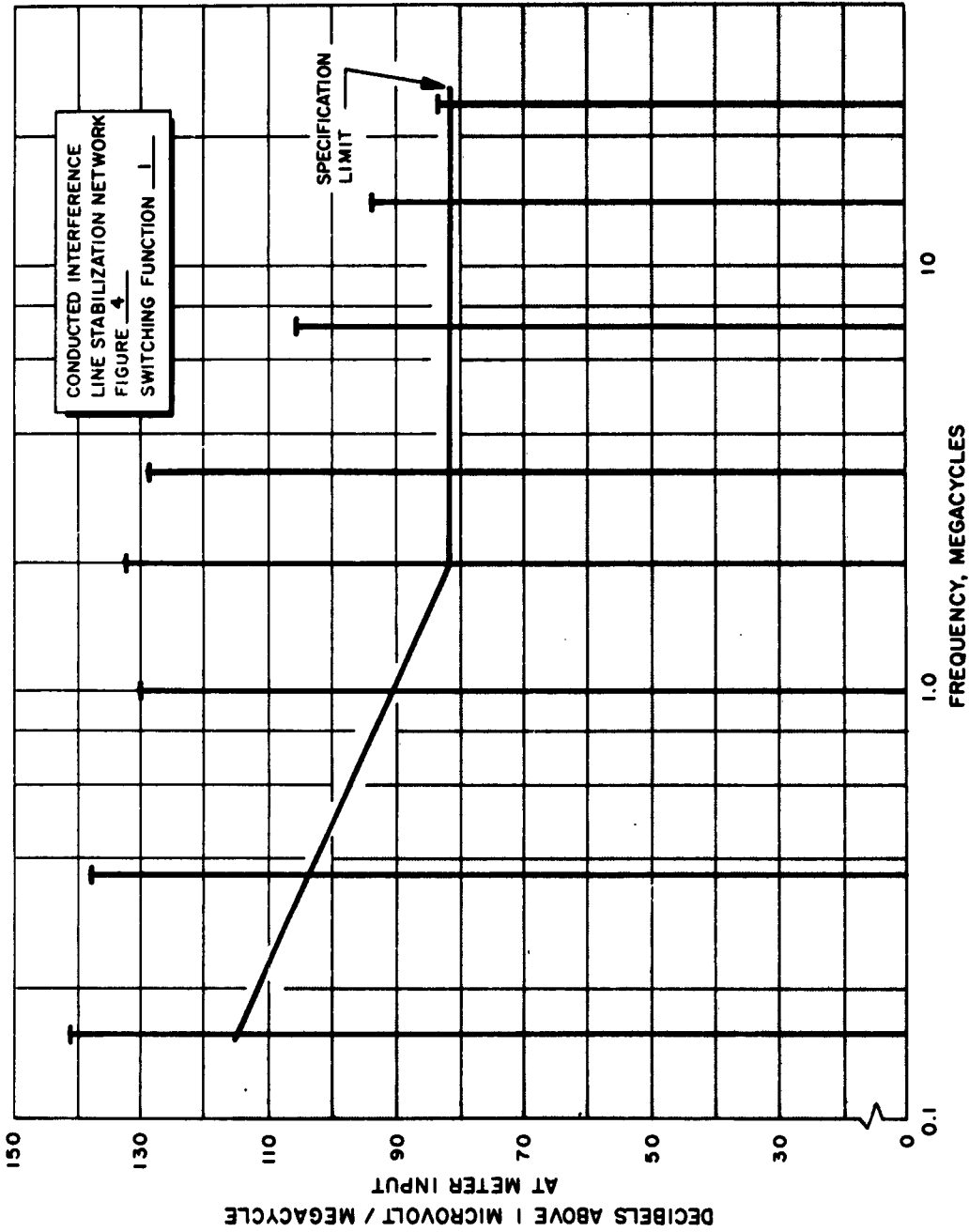

Figure 4 . Switching Function 1 of Conducted Interference Line Stabilization Network

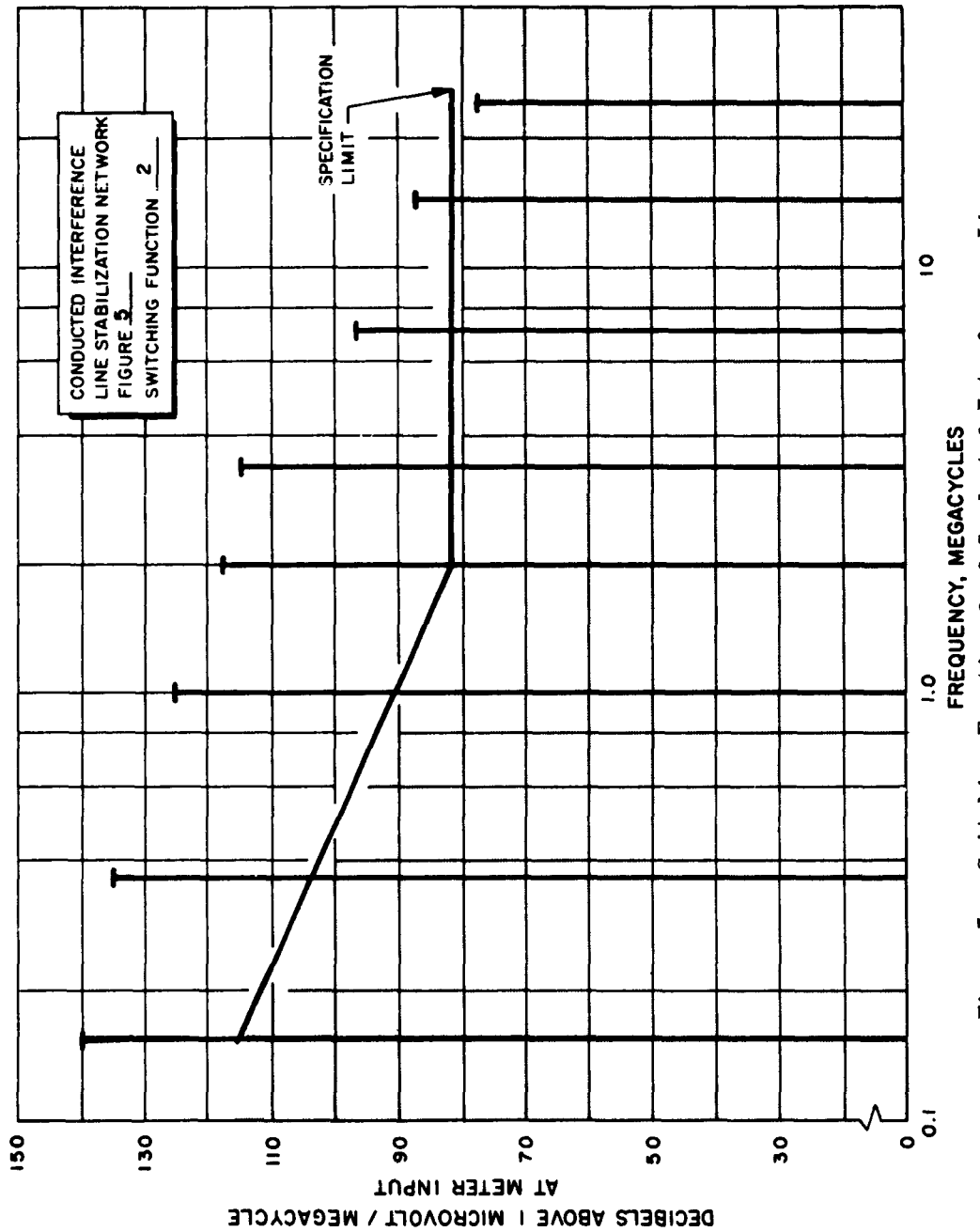

Figure 5. Switching Function 2 of Conducted Interference Line Stabilization Network

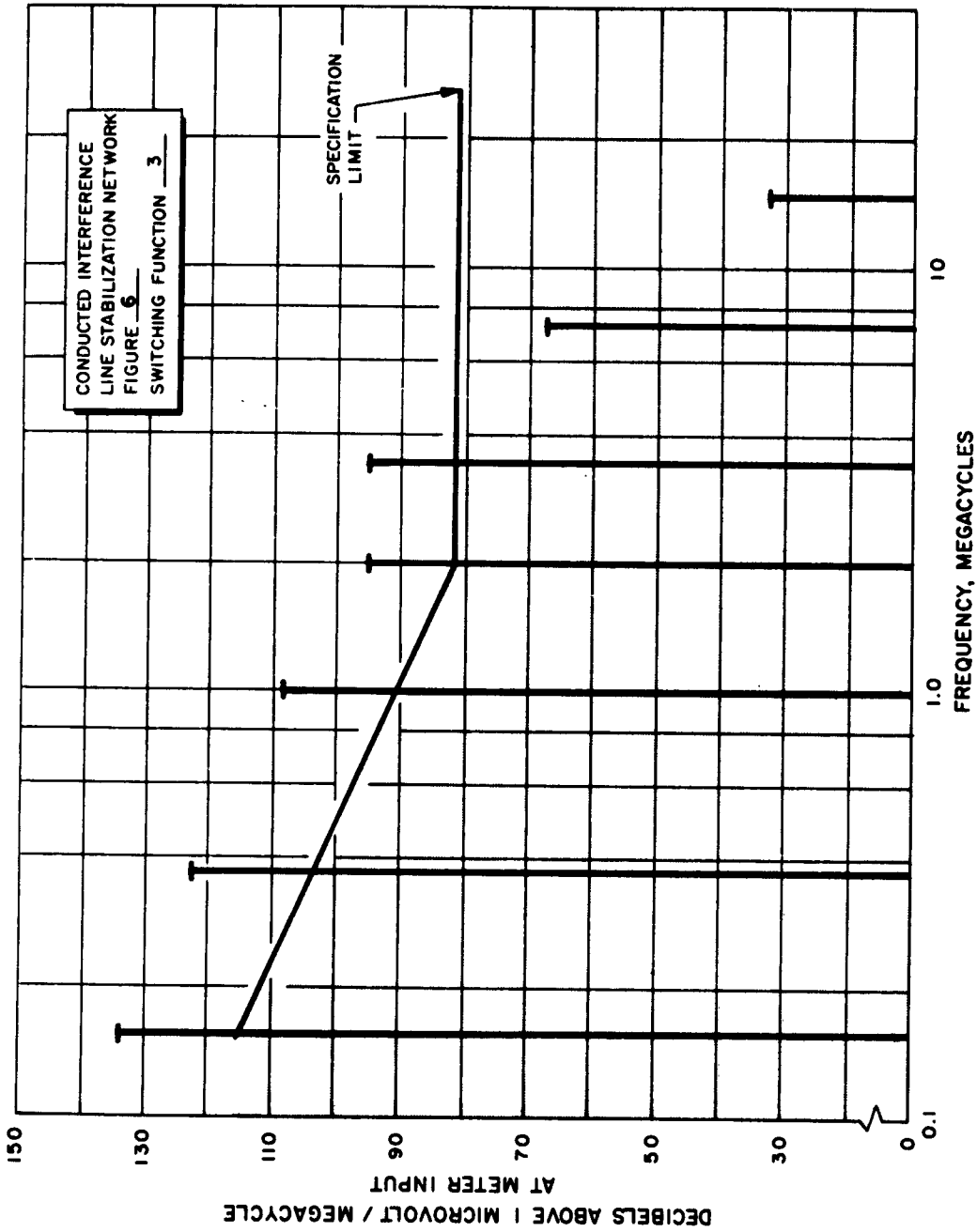

Figure 6. Switching Function 3 of Conducted Interference Line Stabilization Network

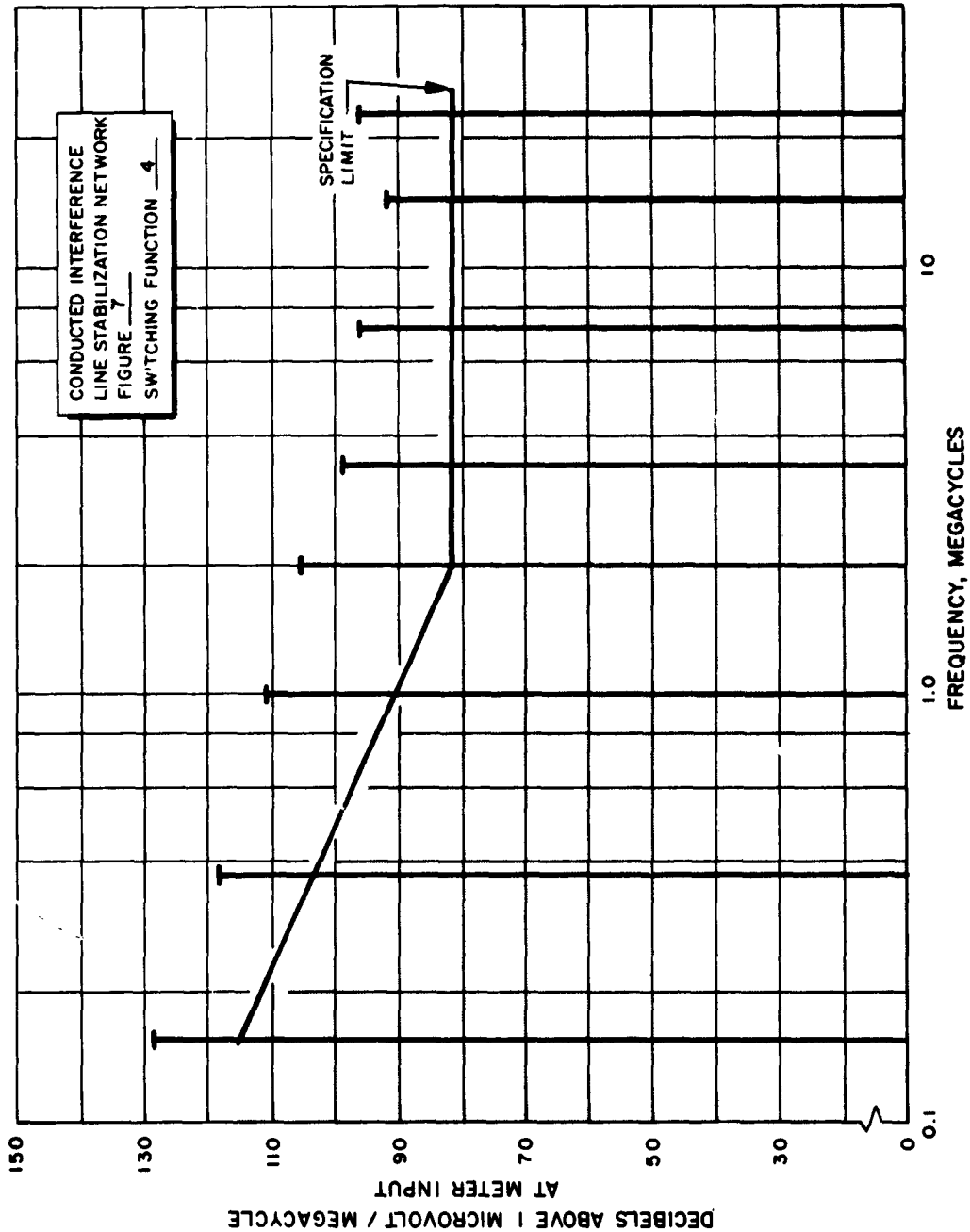

Figure 7. Switching Function 4 of Conducted Interference Line Stabilization Network

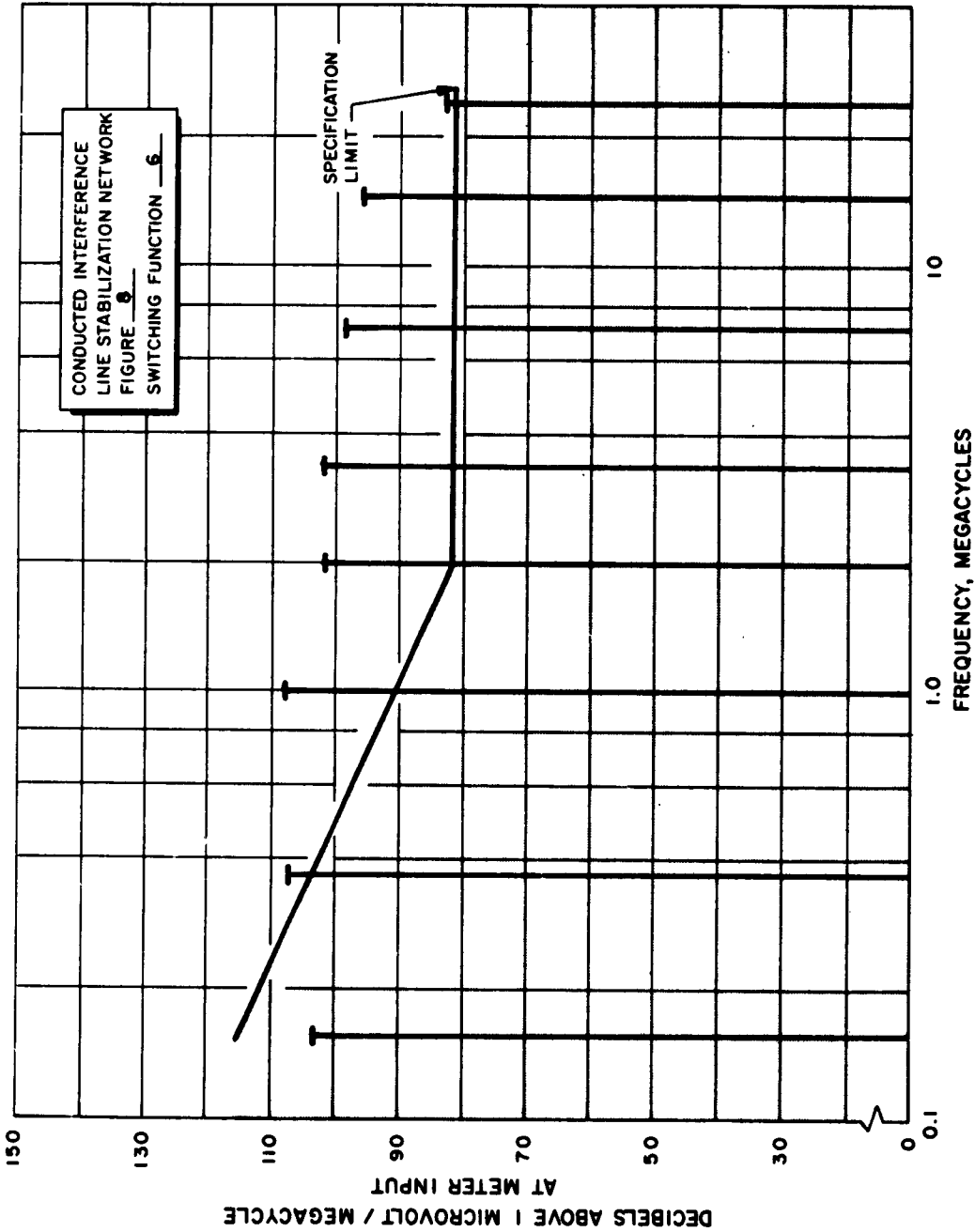

Figure 8. Switching Function 6 of Conducted Interference Line Stabilization Network

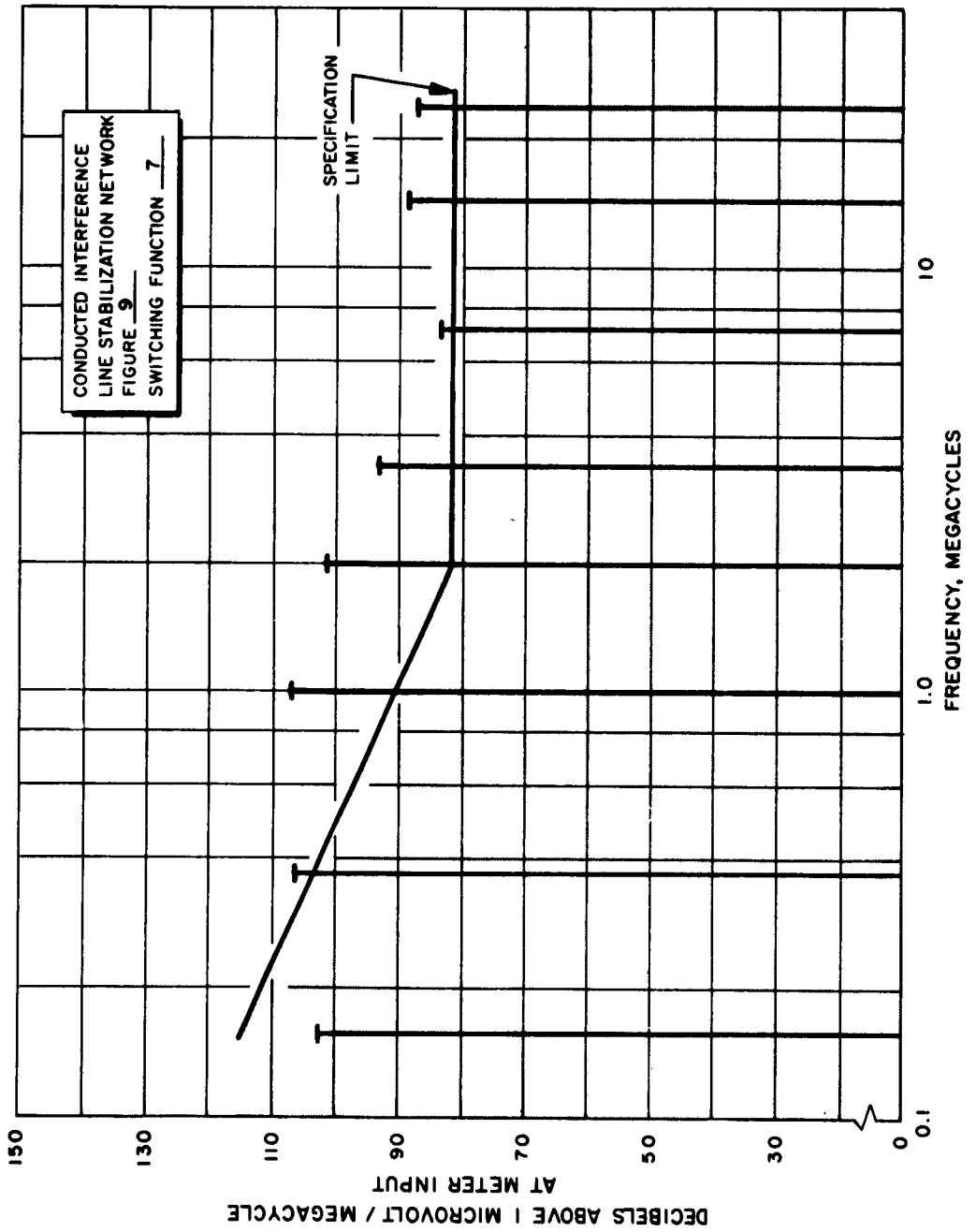

Figure 9. Switching Function 7 of Conducted Interference Line Stabilization Network

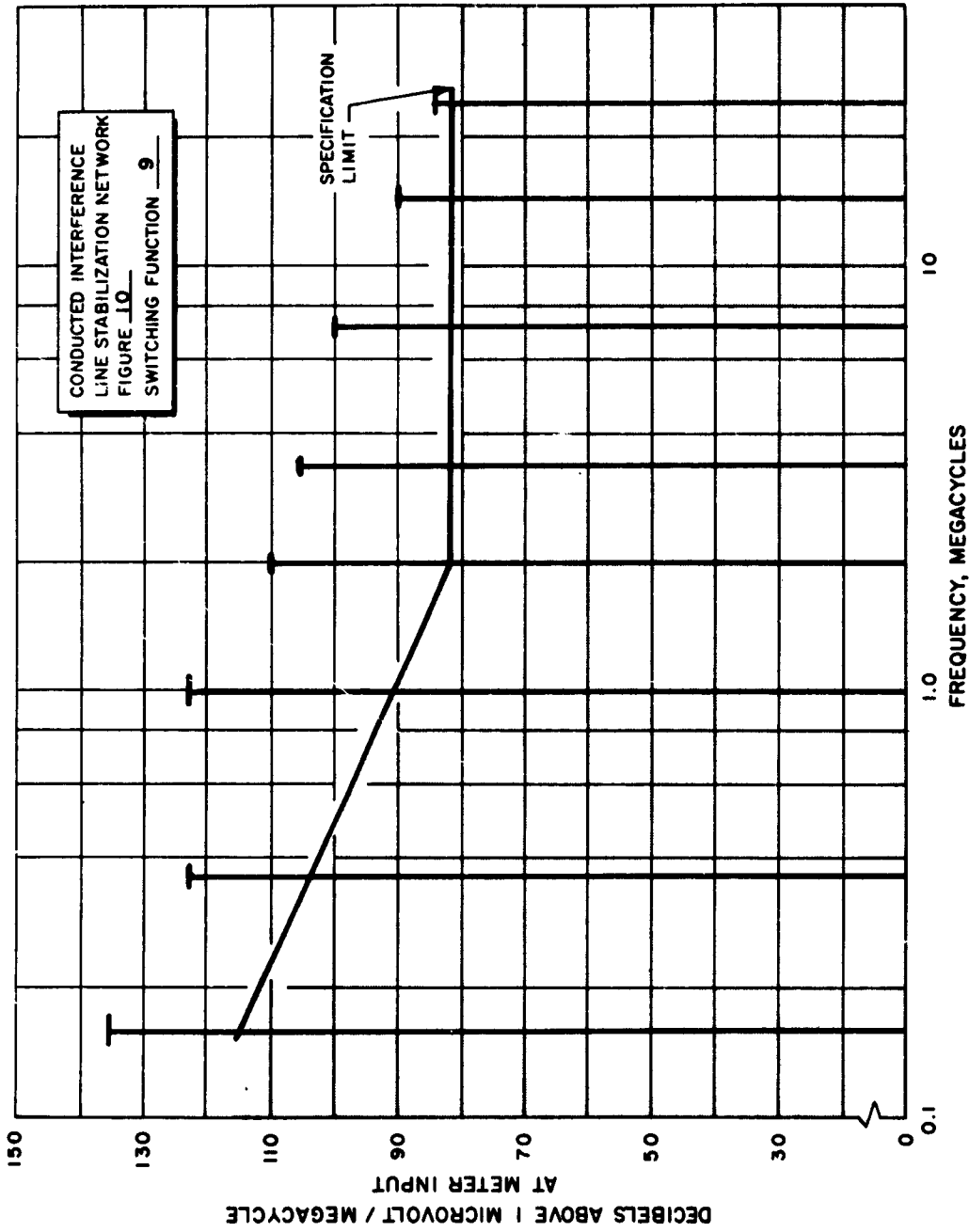

Figure 10. Switching Function 9 of Conducted Interference Line Stabilization Network

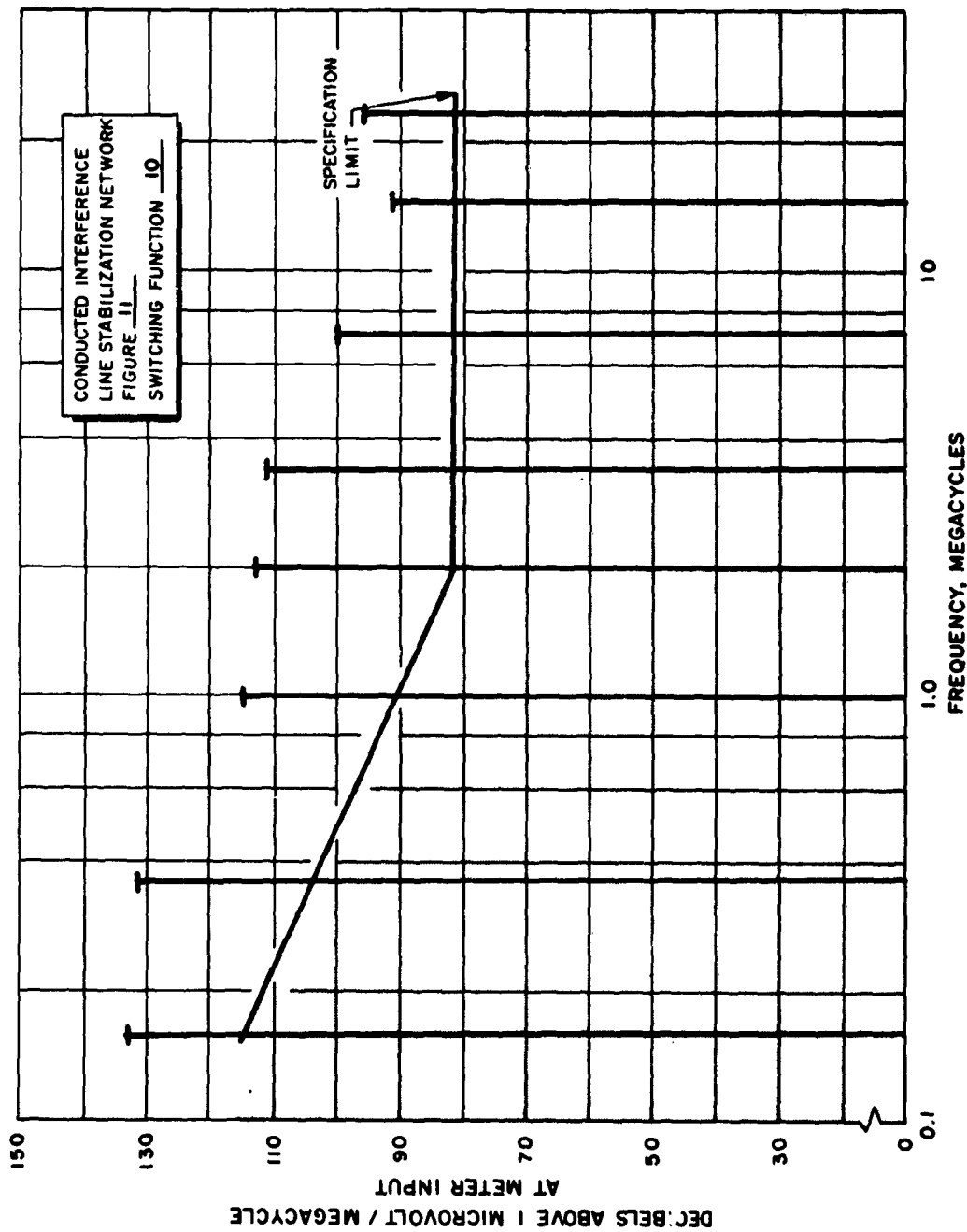

Figure 11 . Switching Function 10 of Conducted Interference Line Stabilization Network

APPENDIX C

CONDUCTED INTERFERENCE USING CURRENT PROBE

Table 3 through 4 and Fig. 12 through 56 present conducted interference data using current probes (paragraph 3.5.1.1.3 of STL document 6201-0004-NU-000).

ROCKETDYNE
A DIVISION OF NORTH AMERICAN AVIATION, INC.

TABLE 3

CONDUCTED INTERFERENCE TEST USING CURRENT PROBE*

Specification Limit = 120 Decibels

Function	Line	Level	Function	Line	Level
6	A	78	3	N	96
7	A	78	7	N	64
9	A	81	4	O	95
10	A	81	7	O	78
1	B	100	4	P	96
2	B	98	7	P	81
4	B	98	3	Q	88
6	B	81	9	Q	81
2	C	75	3	R	82
4	D	81	4	R	84
3	E	96	9	R	78
3	F	88	4	S	89
1	G	38	9	S	78
7	H	28	1	T	100
9	I	26	6	T	83
10	J	46	1	U	98
2	K	100	6	U	79
10	K	83	10	V	32
2	L	96	7	W	28
10	L	80	9	X	50
3	M	95	4	Y	58
7	M	62	7	Y	52
			4	Z	42

*Units given in decibels above 1 μ amp/megacycle at meter input, 30 cps to 15 kilocycles

TABLE 4
CONDUCTED INTERFERENCE TEST USING CURRENT PROBE*

Function	Line	Kilocycles						Megacycles					
		20	50	90	140	160	380	1	2	3.5	7	14	24
6	A	145	131	127.5	122	96	90	84	79.2	56	66	59.2	43.3
7	A	142	113	103.5	95	94	90	83	81.2	69	66	55.2	50.3
9	A	139	133	126.5	125	97	96	86	84.2	67	63	60.2	42.3
10	A	140	116	104.5	102	89	82	74	84.2	75	69	67.2	53.3
1	B	164	151	135.5	129	127	115	99	94.2	89	80	68.2	57.3
2	B	163	150	126.5	132	124	112	96	89.2	84	81	58.2	42.3
4	B	156	147	140.5	133	121	109	97	91.2	83	80	64.2	64.3
6	B	138	129	126.5	122	97	92	82	75.2	72	70	62.2	49.3
2	C	131	124	119.5	116	114	105	92	85.2	80	69	51.2	41.3
4	D	141	131	126.5	126	121	108	99	93.2	80	75	63.2	65.3
3	E	160	150	139.5	125	127	114	104	77.2	53	28	--	--
3	F	147	137	136.5	129	129	112	87	72.2	46	34	--	--
1	G	102	85	73.5	71	72	71	74	80.2	77	73	65.2	
7	H	89	73	67.5	72	68	66	61	55.2	56	62	53.2	49.3
9	I	80	73	73.5	75	73	70	62	65.2	66	68	66.2	49.3
10	J	80	77	78.5	78	78	83	83	80.2	78	83	68.2	67.3
2	K	162.7	149	129.5	134	130	115	102	93.2	84	80	77.2	71.3
10	K	138	131.5	125.5	123.5	122	110	95	90.2	91	91	79.2	70.3
2	L	163	149	138.5	130.5	127.5	116	100	86.2	84	81	72.2	67.3
10	L	136	129	125.5	120.5	117	110	91	91.2	91	87	76.7	61.3

*Units given in decibels above 1 μ amp/megacycle at meter input, 15 kilocycles to 25 megacycles.

TABLE 4
(Continued)

Function	Line	Kilocycles						Megacycles					
		20	50	90	140	160	380	1	2	3.5	7	14	24
3	M	156.7	158	150.5	134	129.5	115.5	103	98.7	90	87	74.7	59.3
7	M	134	124.5	114.5	108	102	98.5	91	83.2	75	74	70.2	57.3
3	N	158	159	149.5	131.5	132	113	101.5	95.7	89.5	83	84.7	67.3
7	N	134	128	114.5	106	102.5	101	89	84.2	79	64	82.7	69.8
4	O	158.7	158	155.5	146	142	130.5	111	99.2	85	84	72.7	62.3
7	O	137.7	129.5	125.5	120.5	121	111.5	103.5	95.7	89	83.5	72.2	63.3
4	P	160	158	154.7	145.7	139.2	126	106.5	98.7	89	79	77.2	81.8
7	P	137.5	128.5	125.2	121	117	112.5	101.5	97.7	87.5	77	88.7	74.3
3	Q	150	145	146	139	131.5	115	102	96.2	89.5	86	84.2	79.8
9	Q	135.5	121.5	128	120.5	121.5	110.5	98.5	92.2	78	80.5	76.7	63.3
3	R	147.2	145.7	146.5	137.7	127	115.5	105.5	100.2	94	81.5	80.2	79.8
4	R	149	151	152.5	143	138	123.5	106.5	98.2	87.5	76.5	71.7	71.3
9	R	135.5	124	127	125.2	120	109	99.5	92.2	82	78	74.2	66.3
4	S	149.2	150.7	150.2	148.7	147	130.5	111.5	99.2	96.5	82	73.7	82.3
9	S	130.7	124	119	115	115	105.5	95	88.2	82	80.5	80.7	72.3
1	T	163.5	151.5	133.5	130.5	127.5	113	96	89.2	92	83	75.2	72.3
6	T	138	129	125	120.7	120	110.5	100.5	103.7	109	99	93.2	78.3
1	U	163.5	152	135.5	133.5	129	113.5	96	88.2	94	87	70.2	68.3
6	U	137	127.5	124	119	119	110.5	102	105.2	110.5	103.5	88.7	71.8
10	V	79	72	68.5	69	61	53	47	43.2	41	39	42.2	47.3

TABLE 4
(Continued)

Function	Line	Kilocycles						Megacycles					
		20	50	90	140	160	380	1	2	3.5	7	14	24
7	W	96	83	72.5	73	65	57	50	48.2	46	47	46.2	52.3
9	X	85	65	68.5	68	65	54	47	43.2	42	44	43.2	47.3
4	Y	112	112	108.5	99	104	93	88	78.2	73	67	61.2	65.3
7	Y	109	102	99.5	93	92	84	76	66.2	60	60	49.2	53.3
4	Z	97	81	78.5	72	72	61	56	53.2	50	51	51.2	57.3

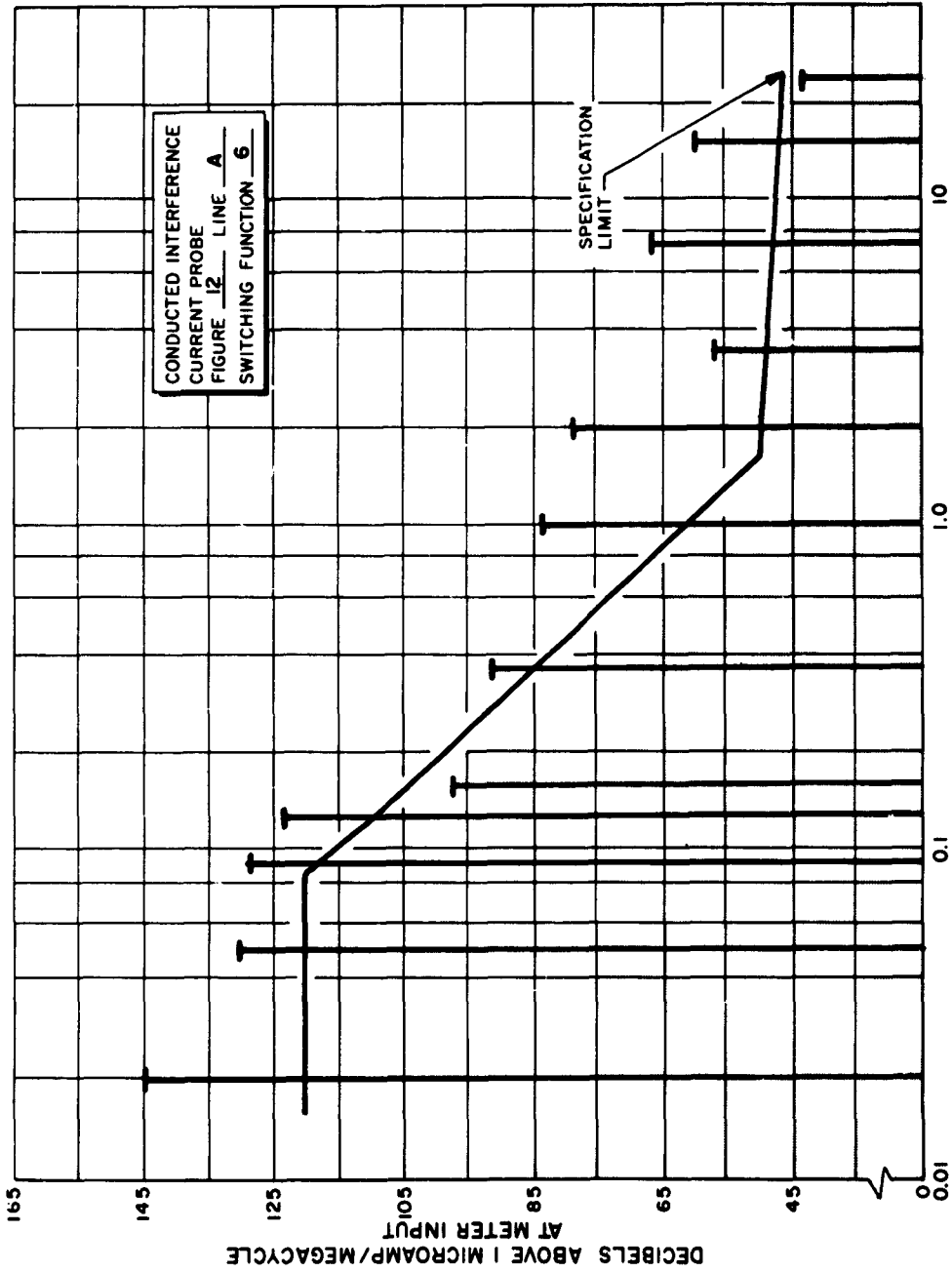

Figure 12. Line A, Switching Function 6 of Conducted Interference Current Probe

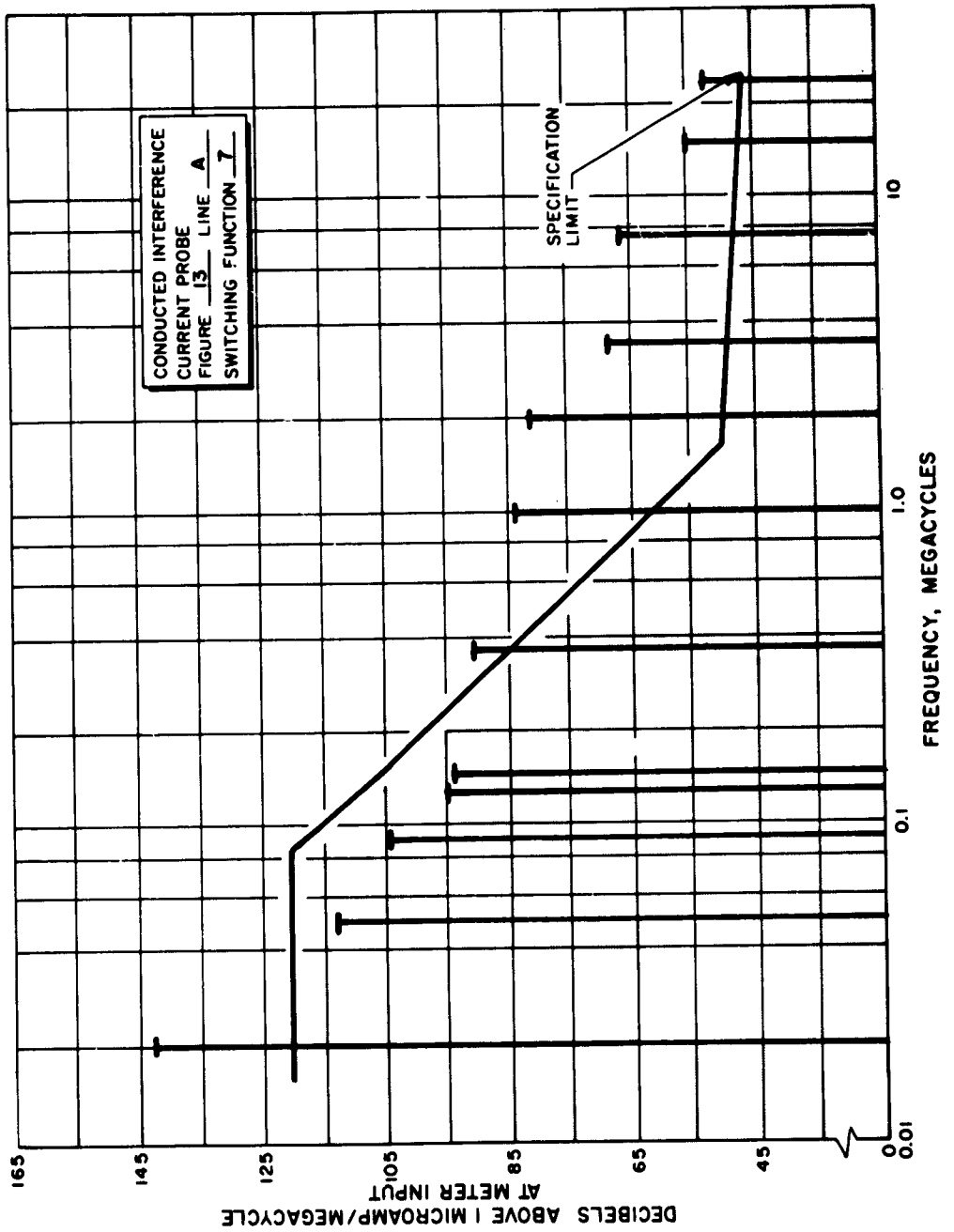

Figure 13. Line A, Switching Function 7 of Conducted Interference Current Probe

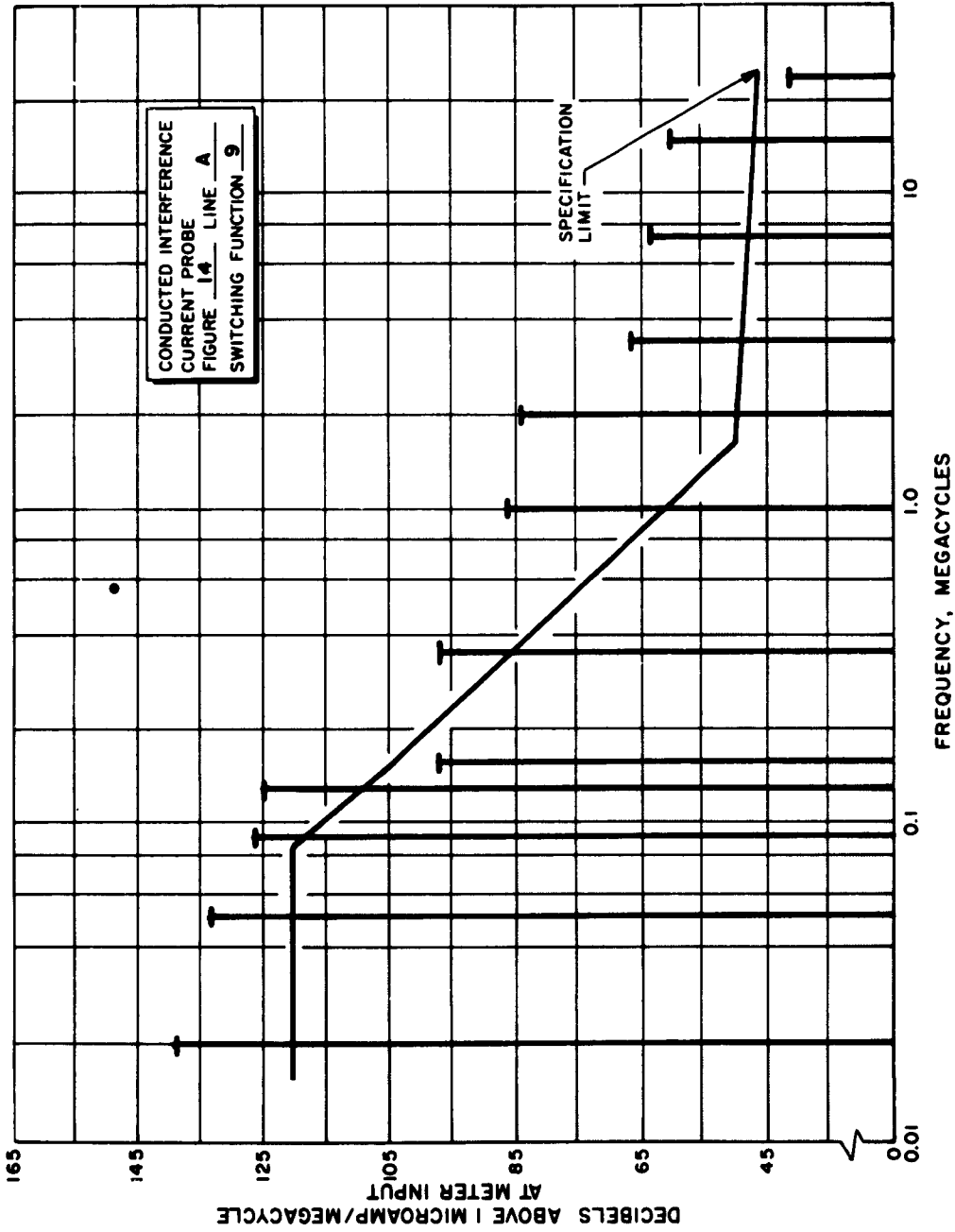

Figure 14. Line A, Switching Function 9 of Conducted Interference Current Probe

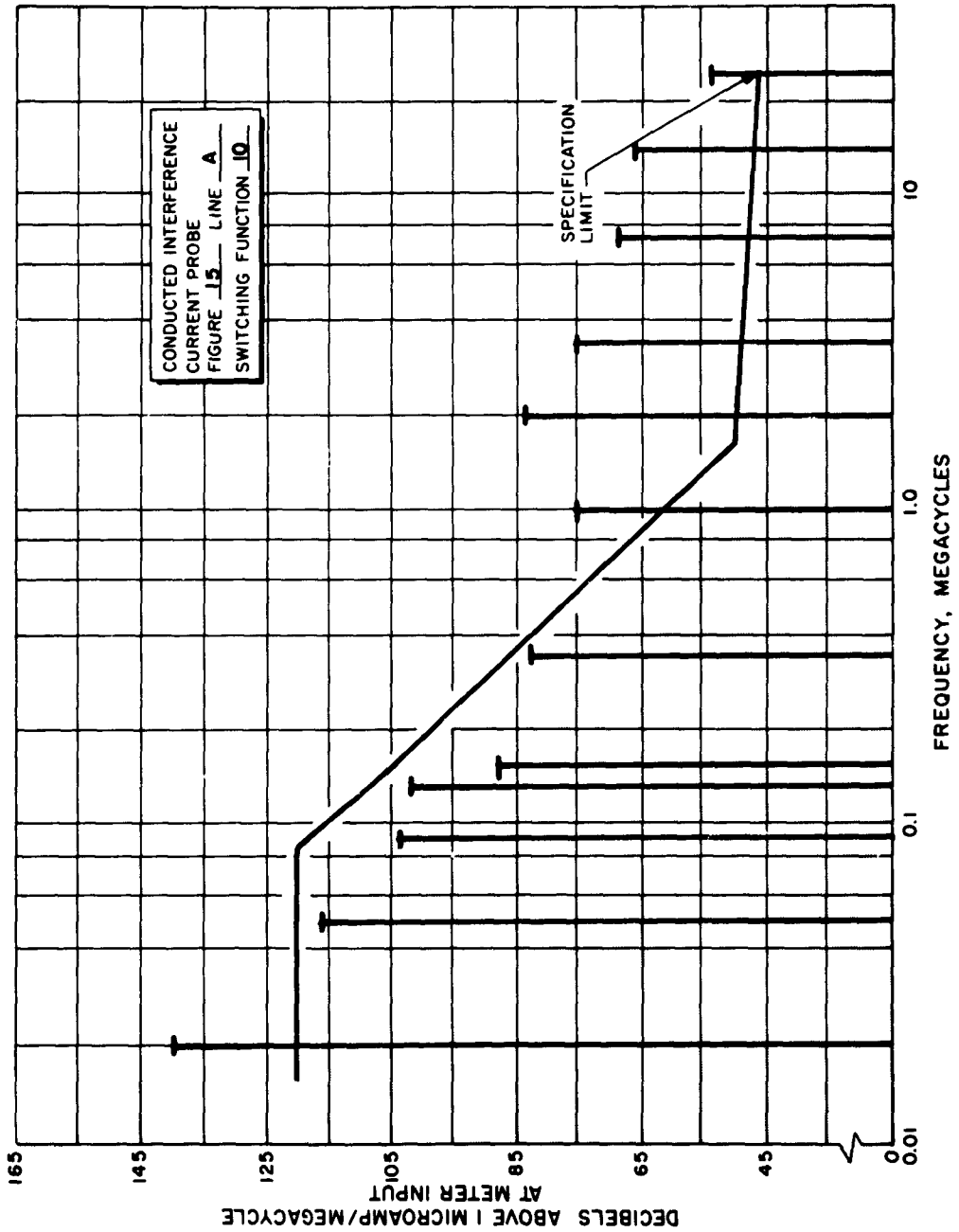

Figure 15. Line A, Switching Function 10 of Conducted Interference Current Probe

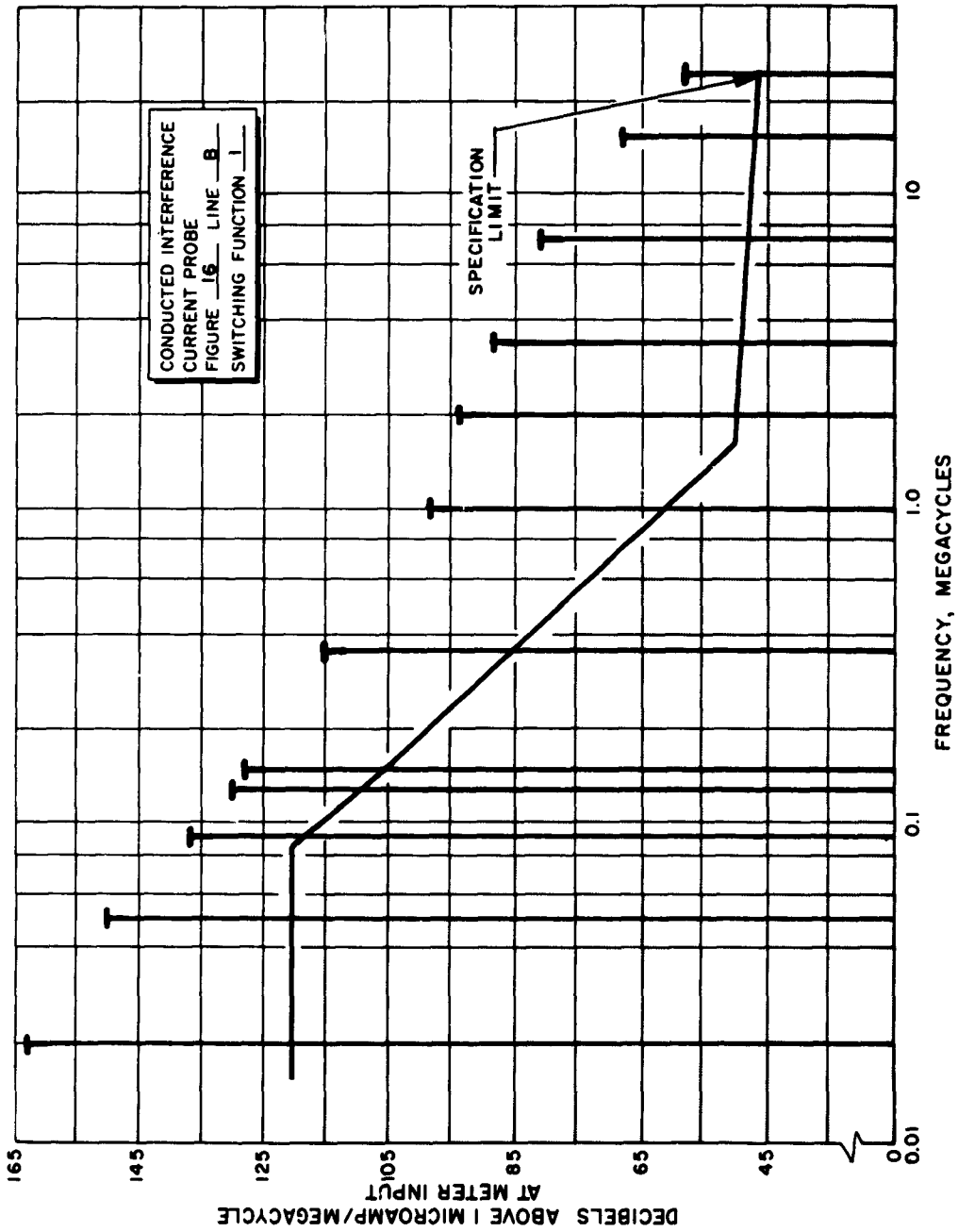

Figure 16. Line B, Switching Function 1 of Conducted Interference Current Probe

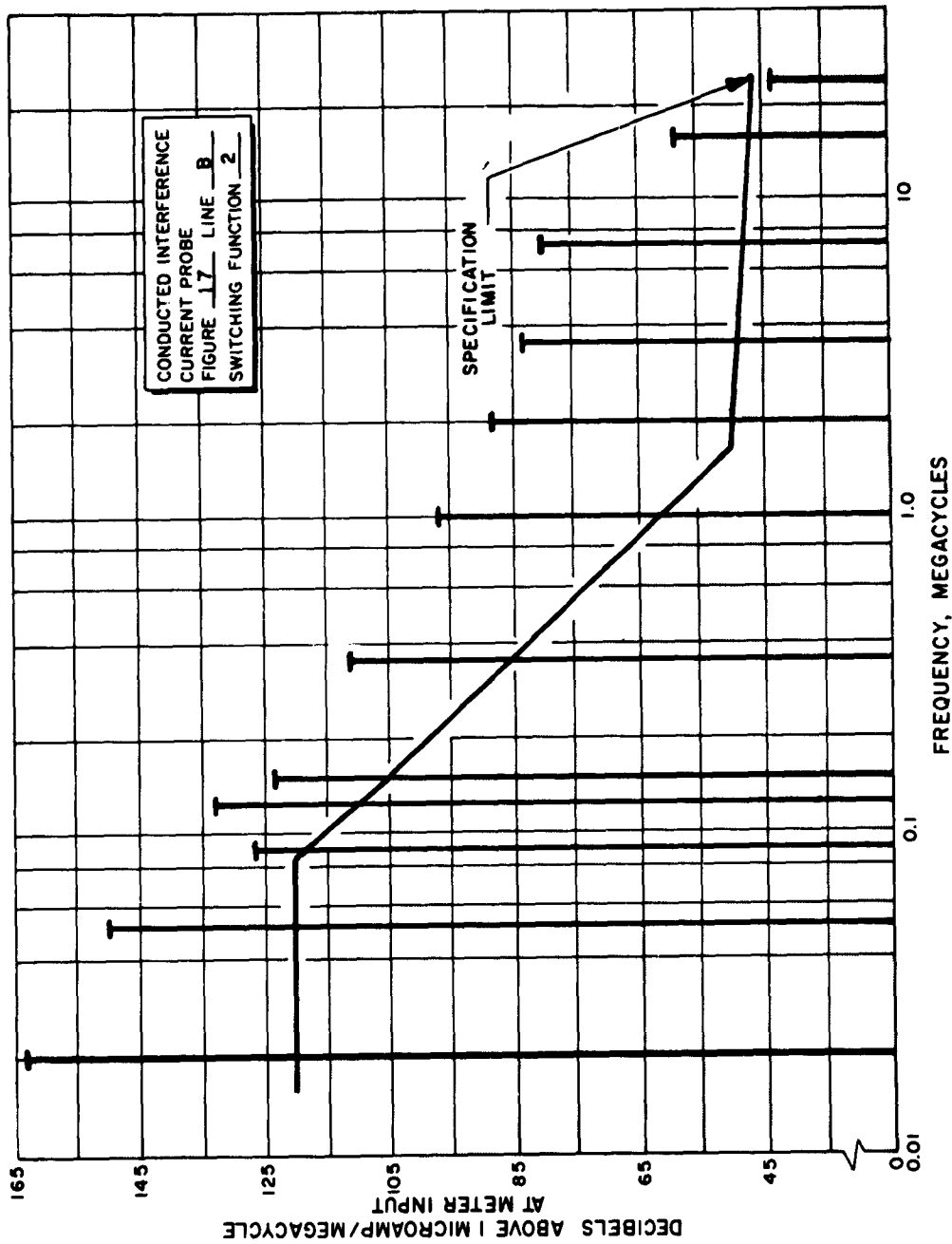

Figure 17. Line B, Switching Function 2 of Conducted Interference Current Probe

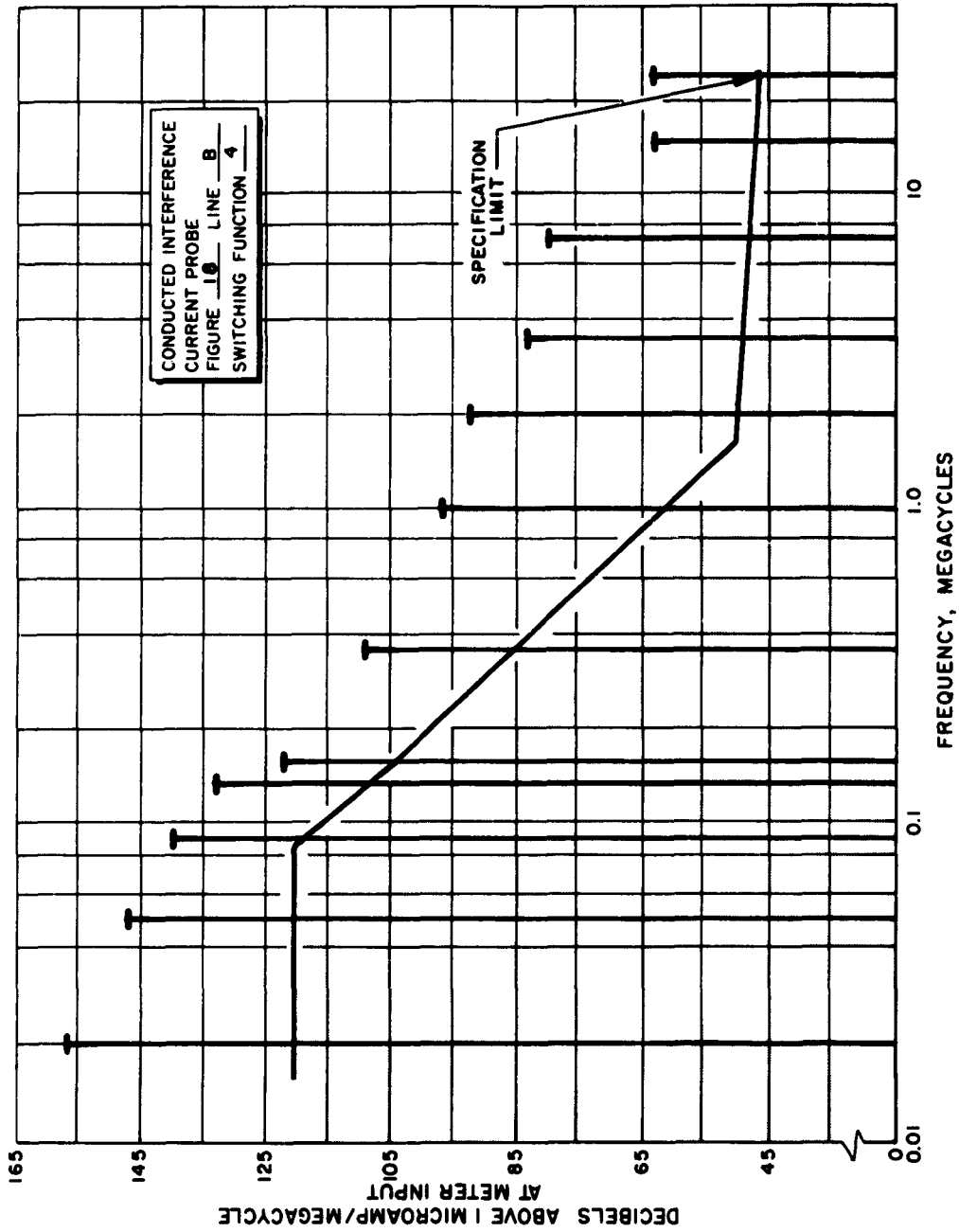

Figure 18. Line B, Switching Function 4 of Conducted Interference Current Probe

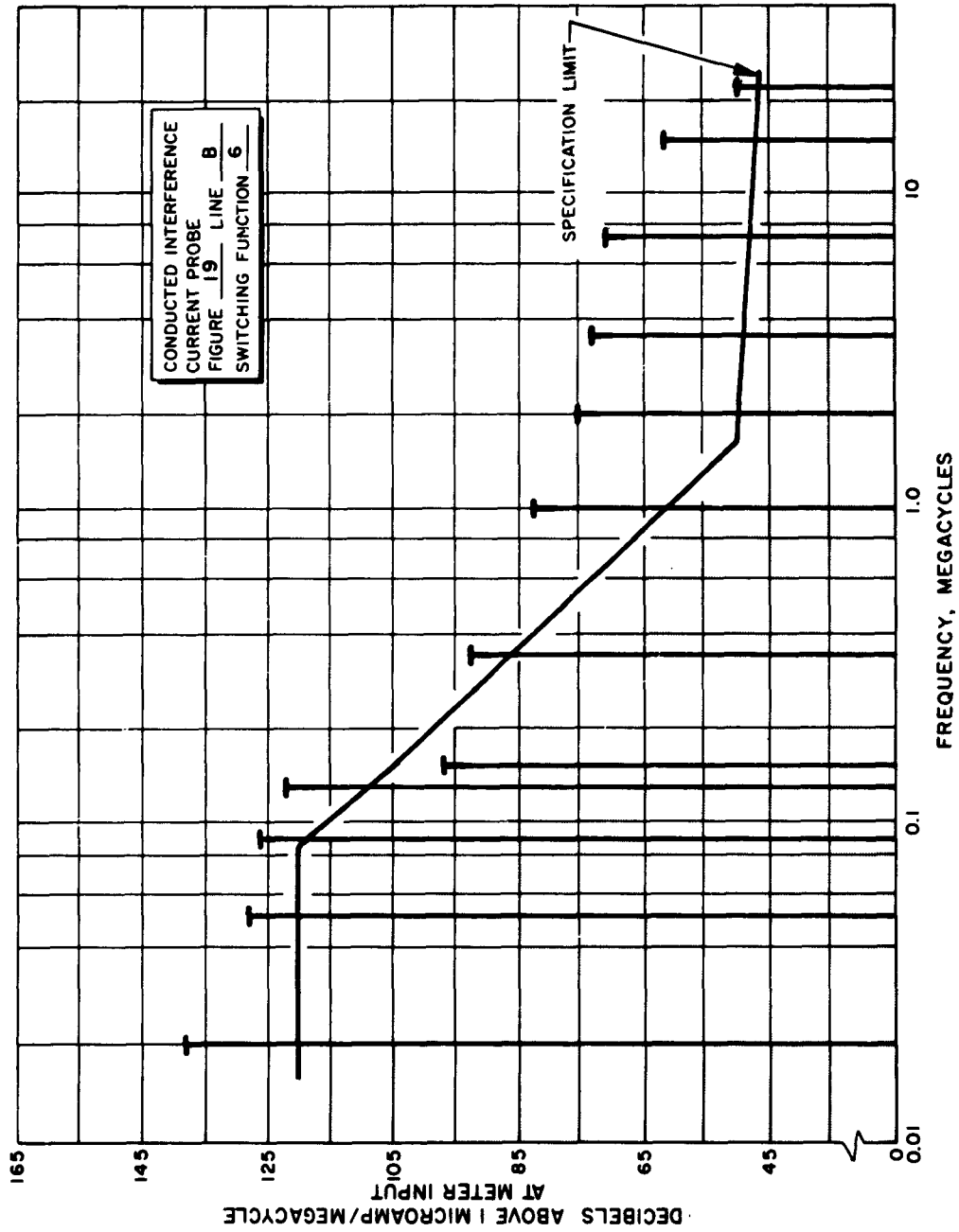

Figure 19. Line B, Switching Function 6 of Conducted Interference Current Probe

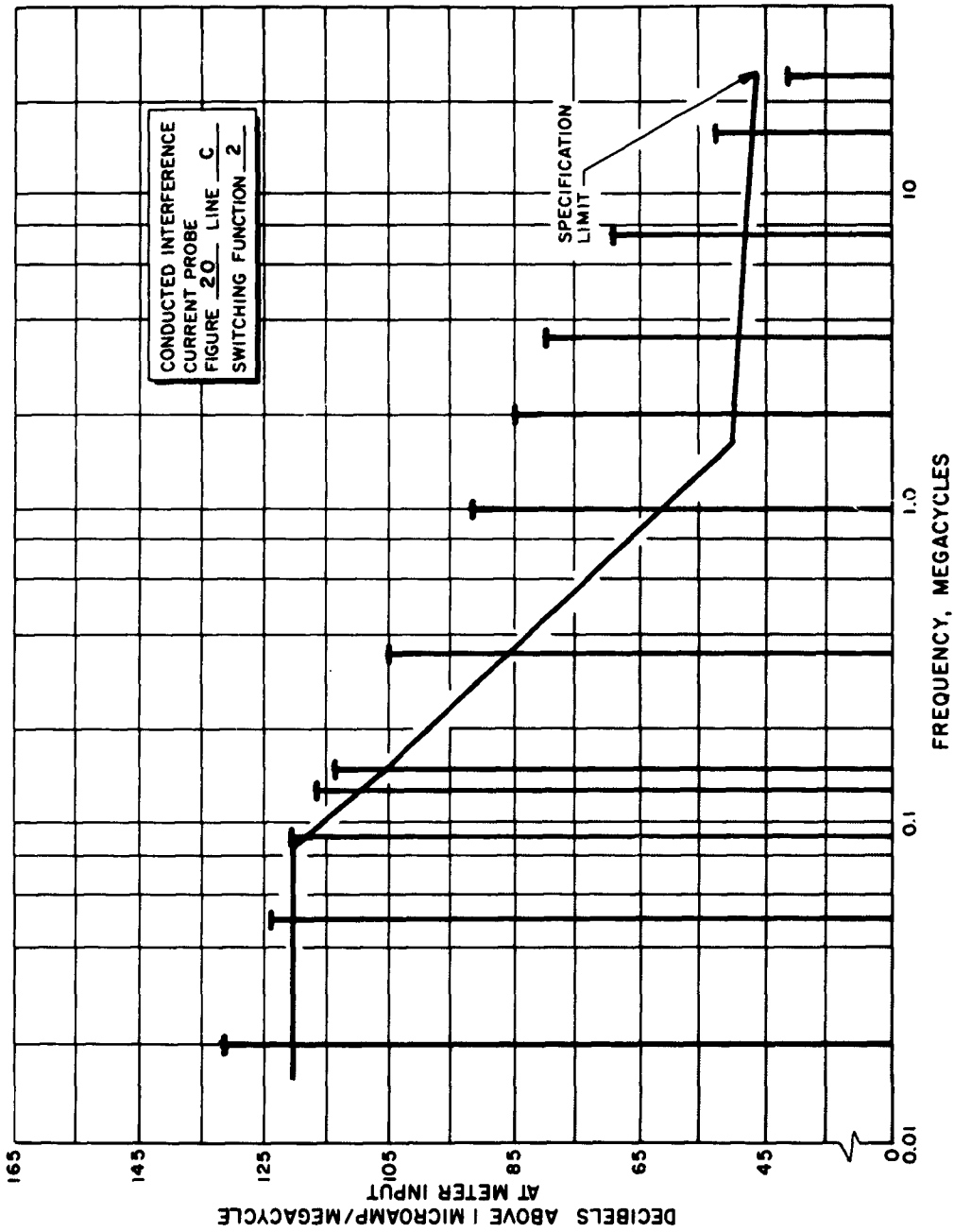

Figure 20 Line C, Switching Function 2 of Conducted Interference Current Probe

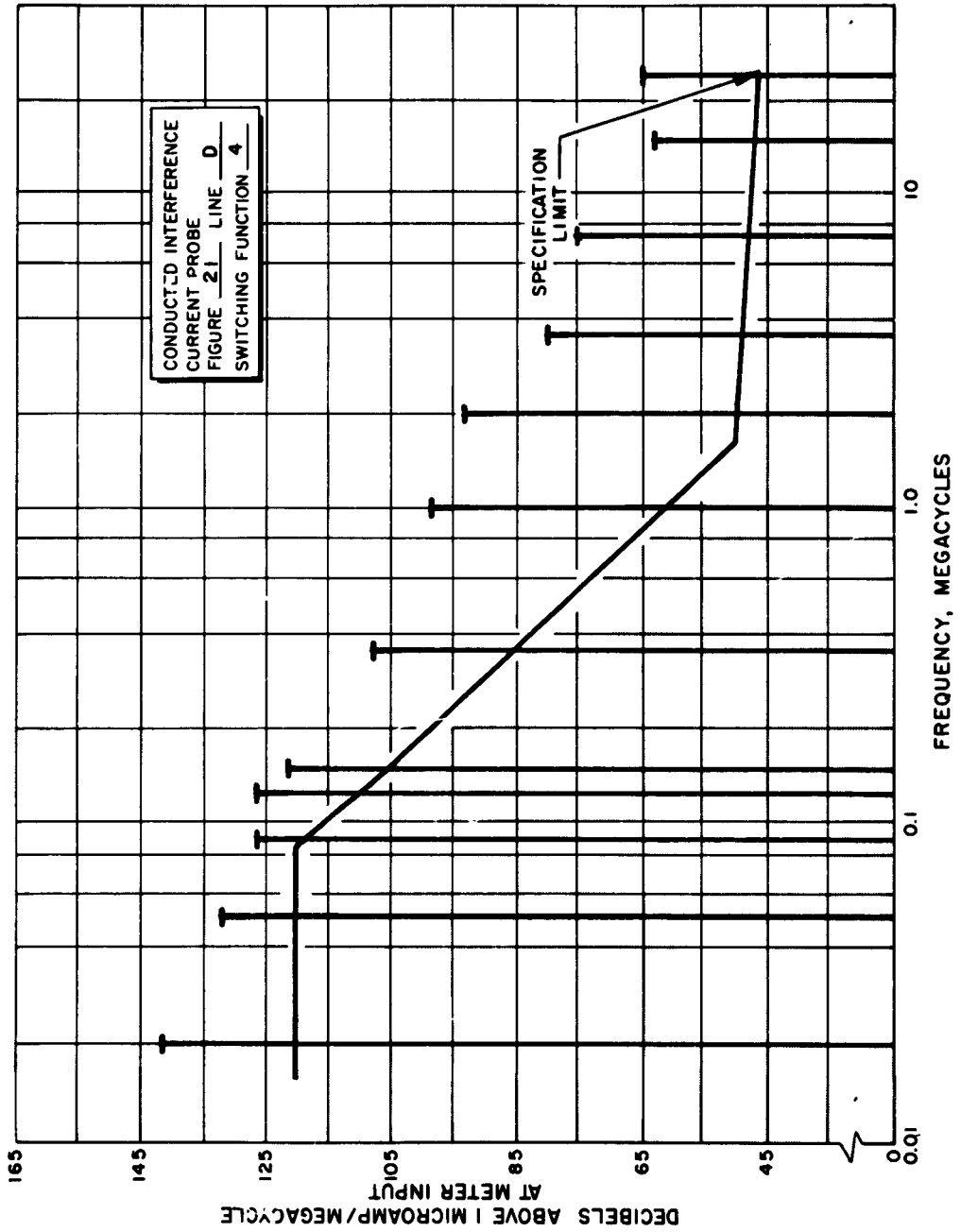

Figure 21. Line D, Switching Function 4 of Conducted Interference Current Probe

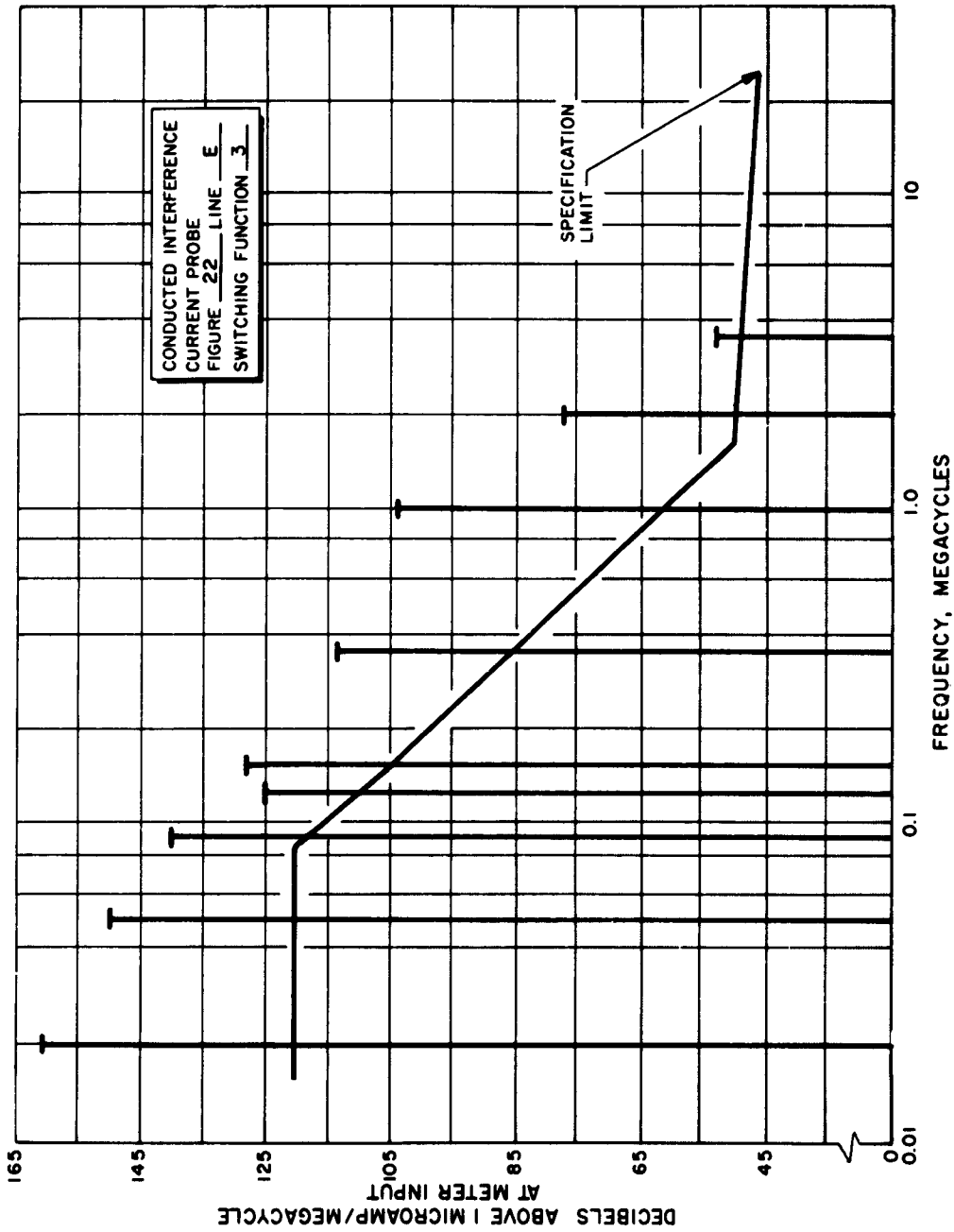

Figure 22. Line E, Switching Function 3 of Conducted Interference Current Probe

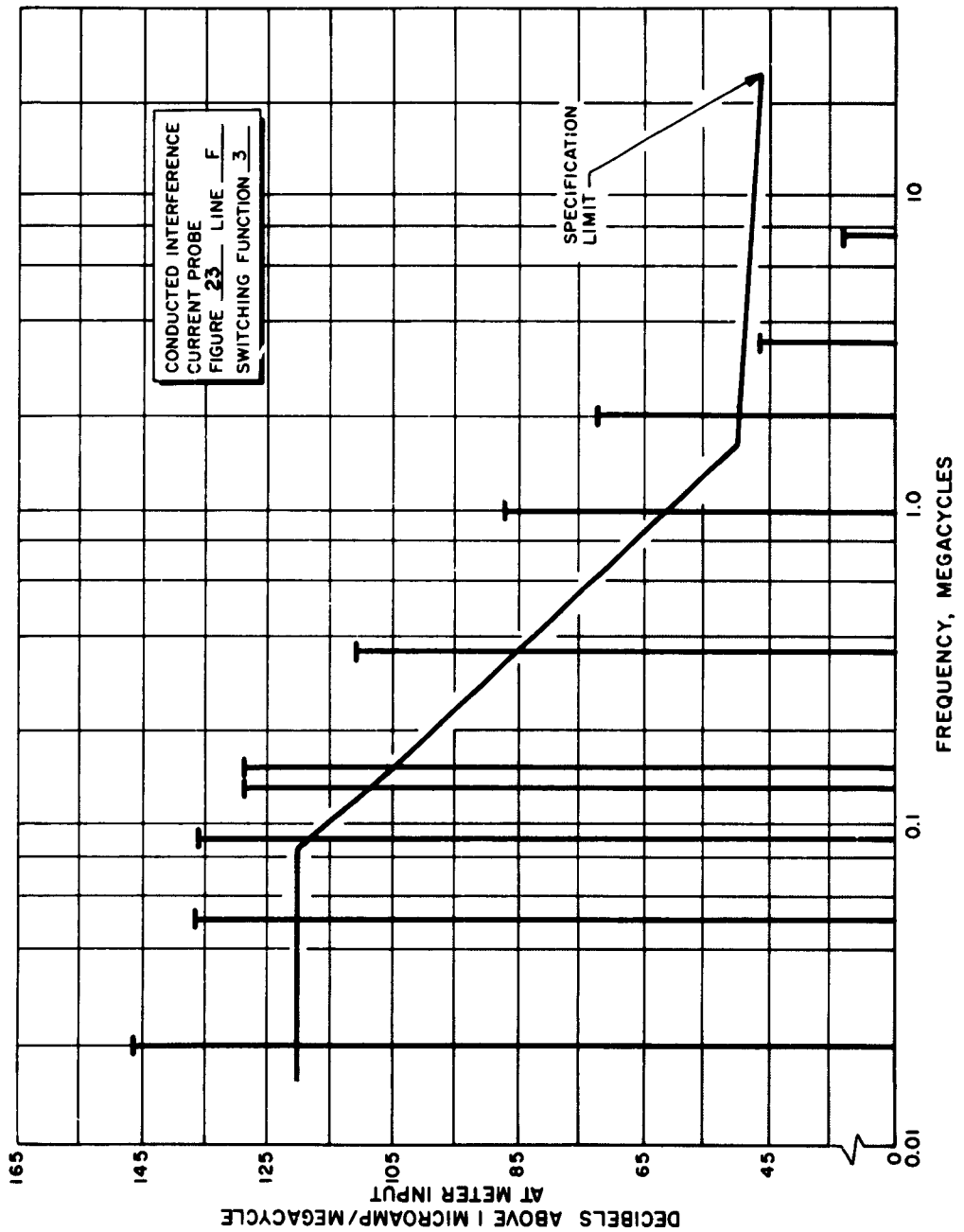

Figure 23. Line F, Switching Function 3 of Conducted Interference Current Probe

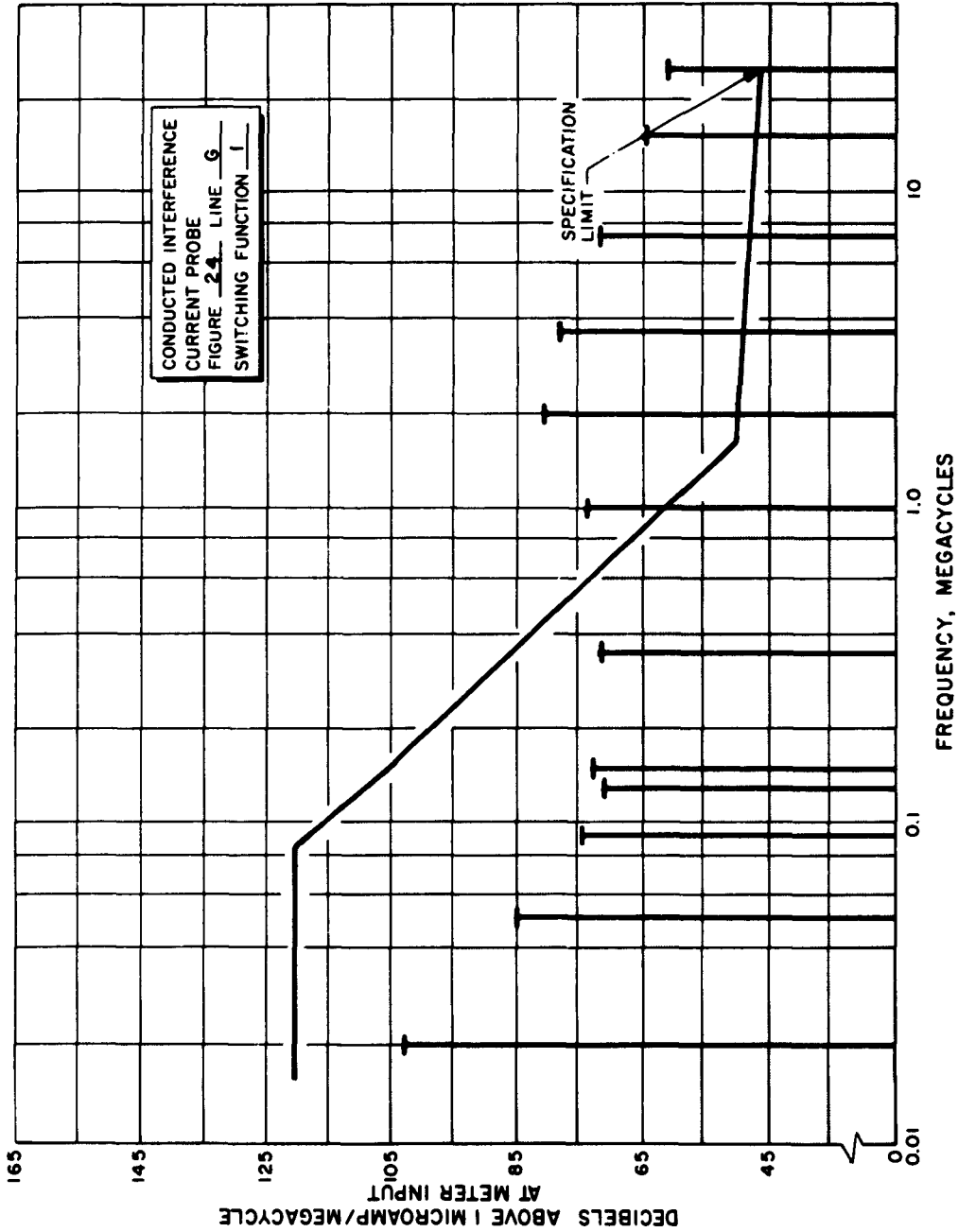

Figure 24 Line G, Switching Function 1 of Conducted Interference Current Probe

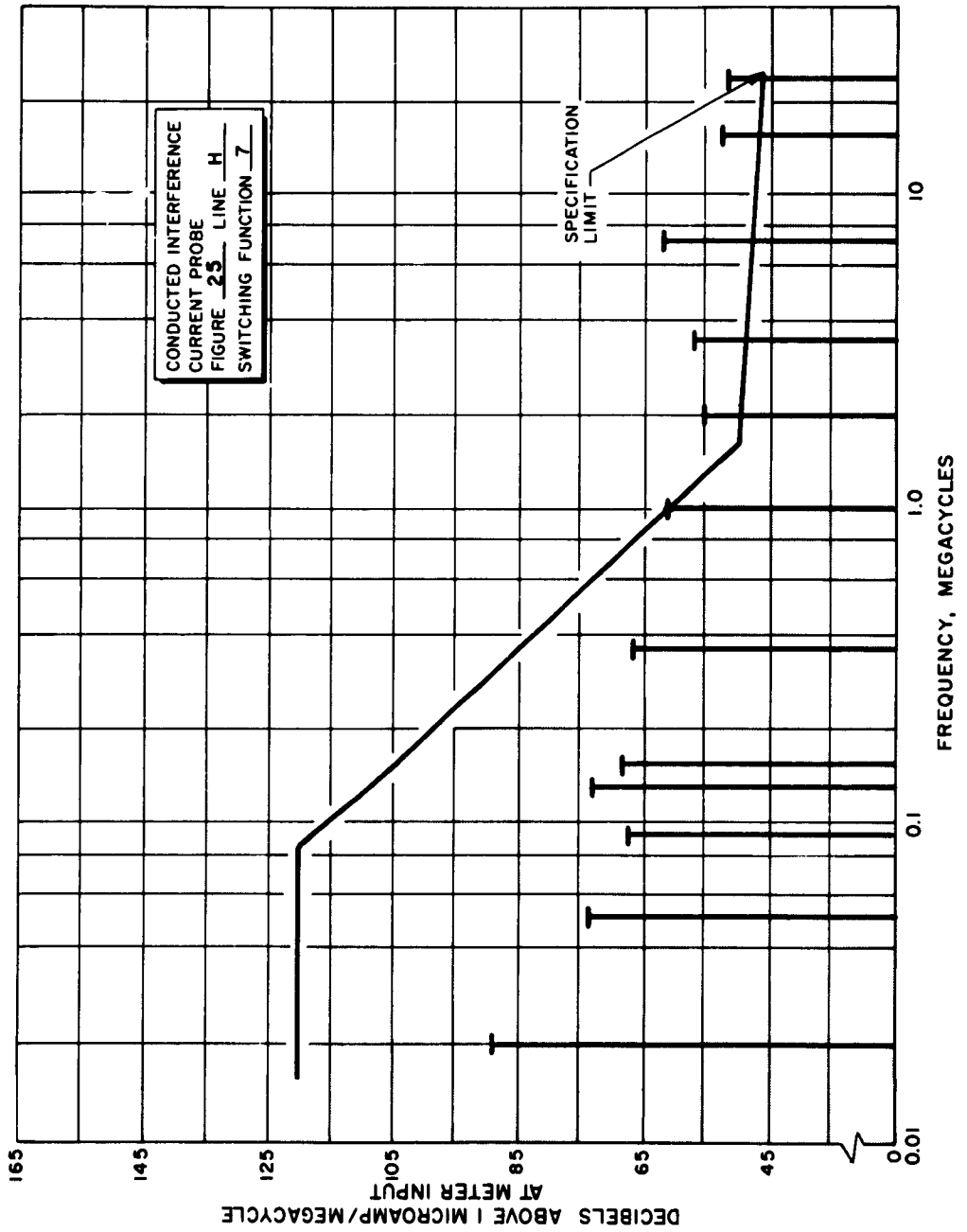

Figure 25. Line H, Switching Function 7 of conducted Interference Current Probe

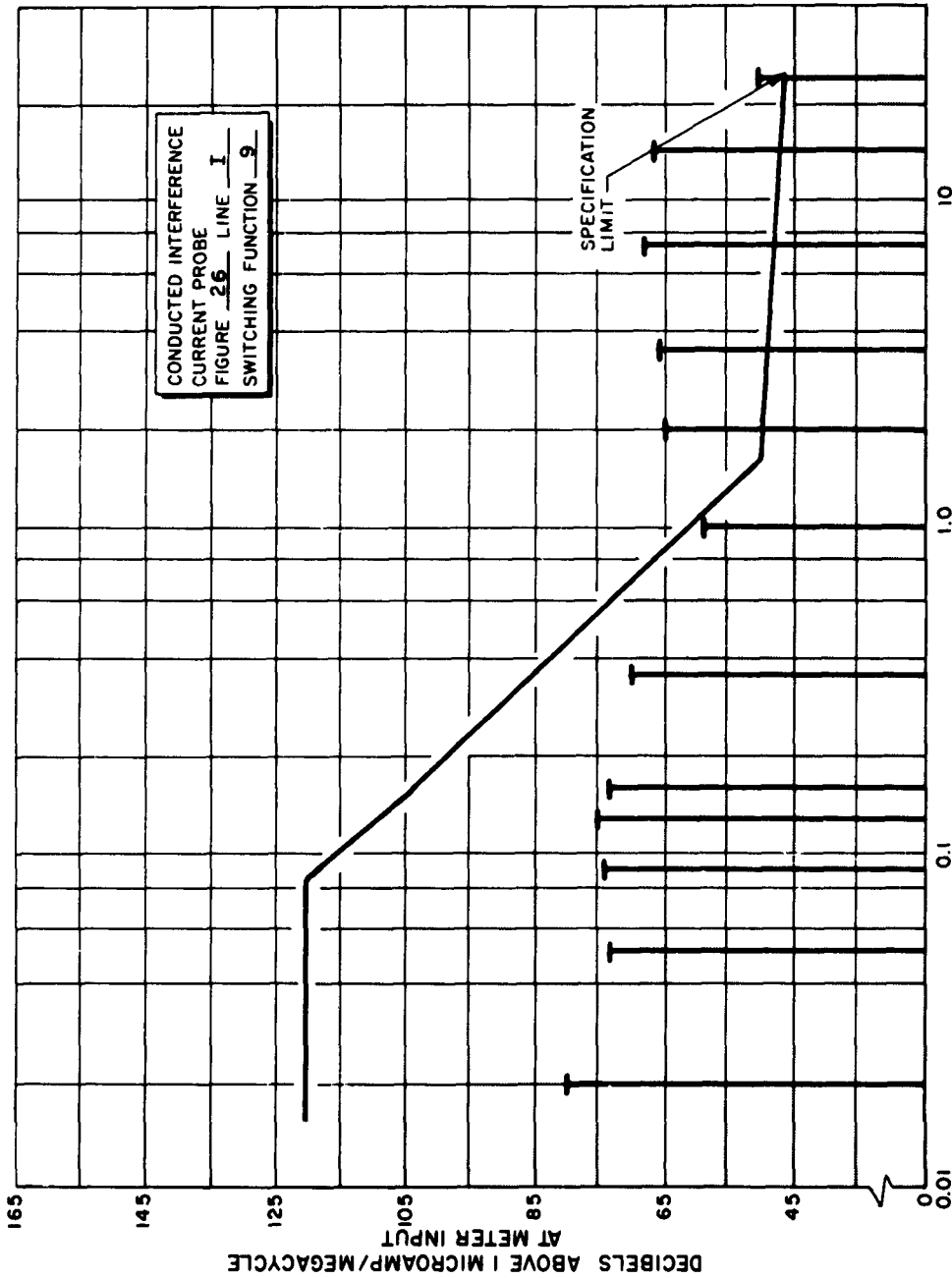

Figure 26. Line I, Switching Function 9 of Conducted Interference Current Probe

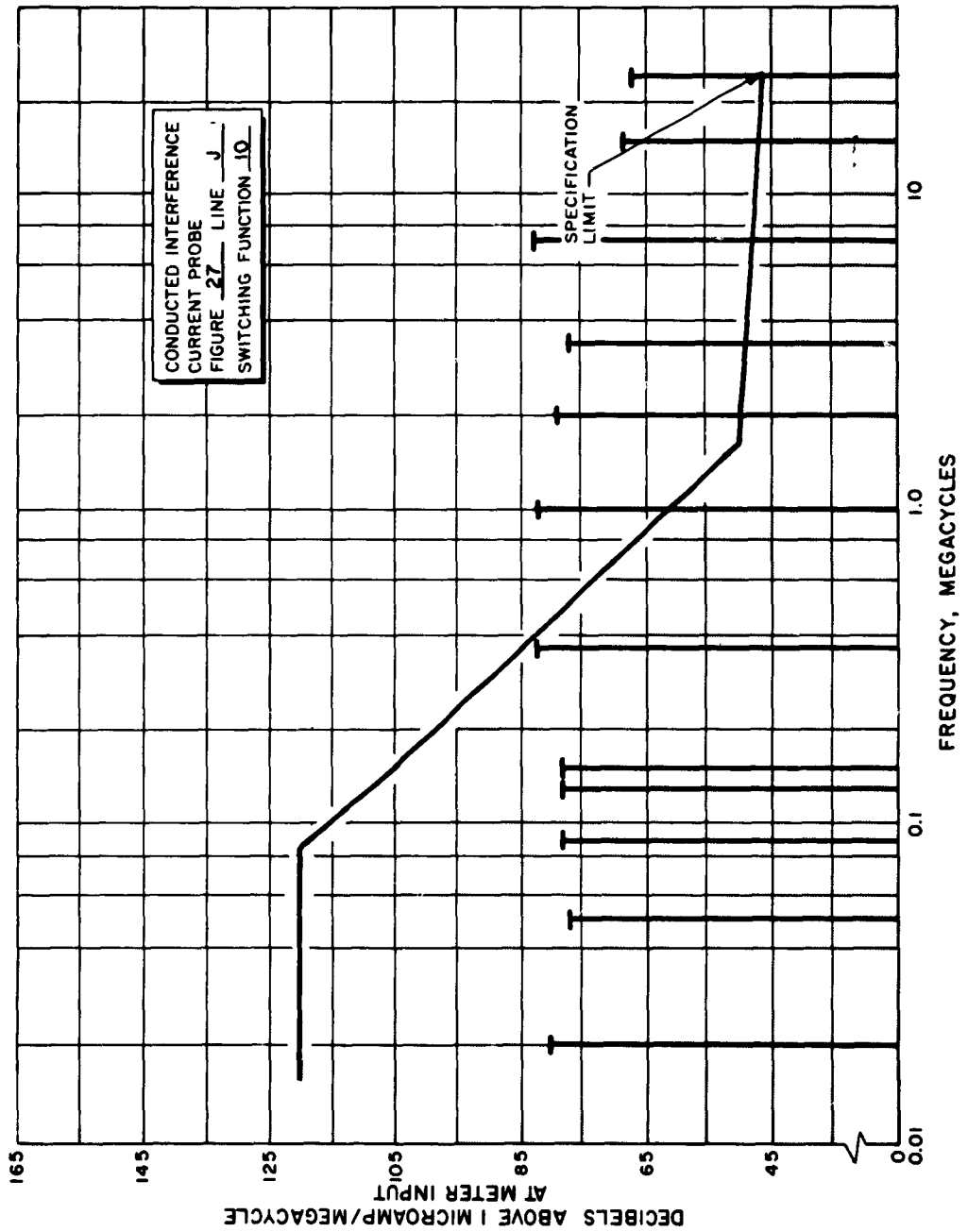

Figure 27. Line J, Switching Function 10 of Conducted Interference Current Probe

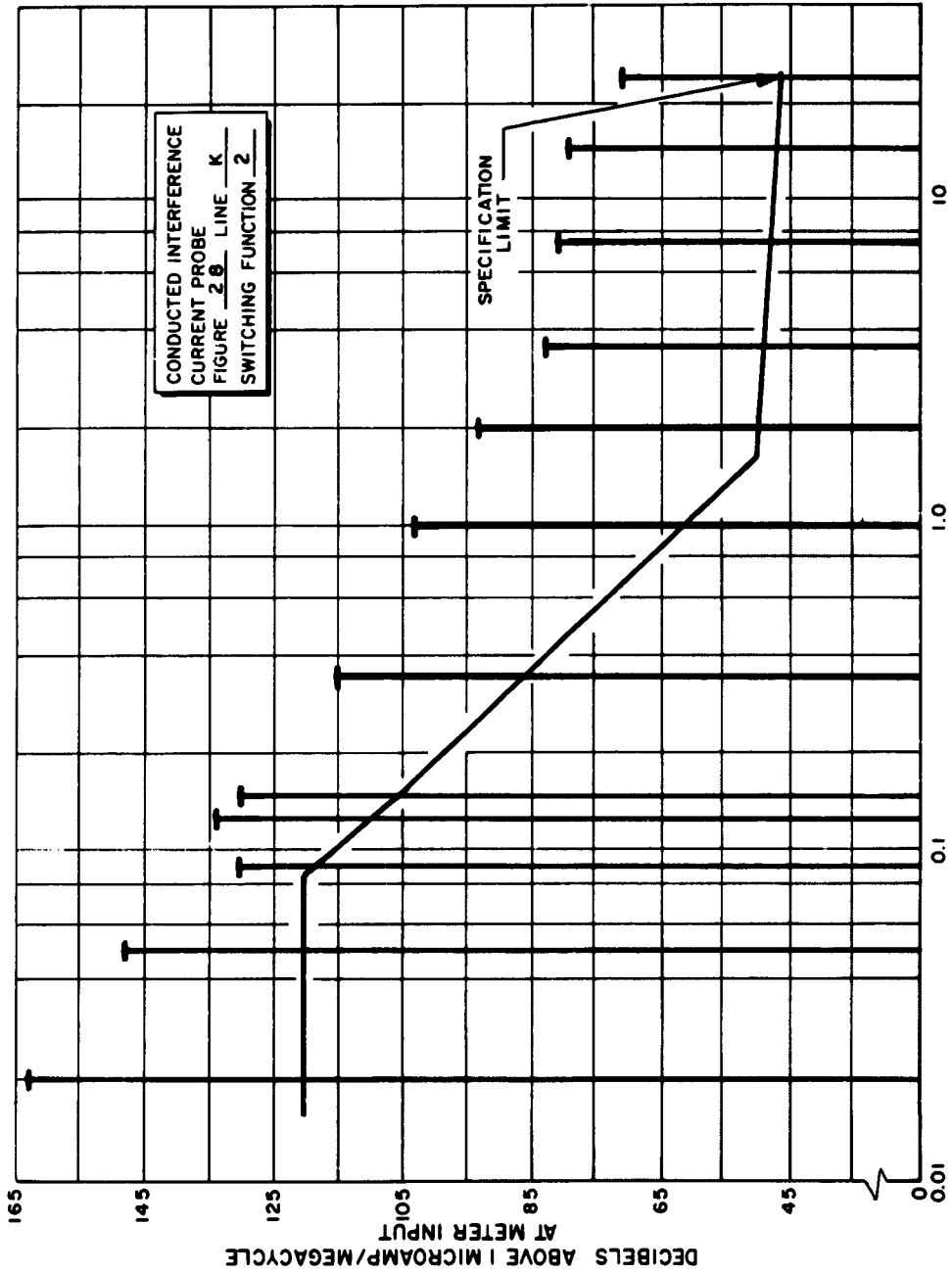

Figure 28. Line K, Switching Function 2 of Conducted Interference Current Probe

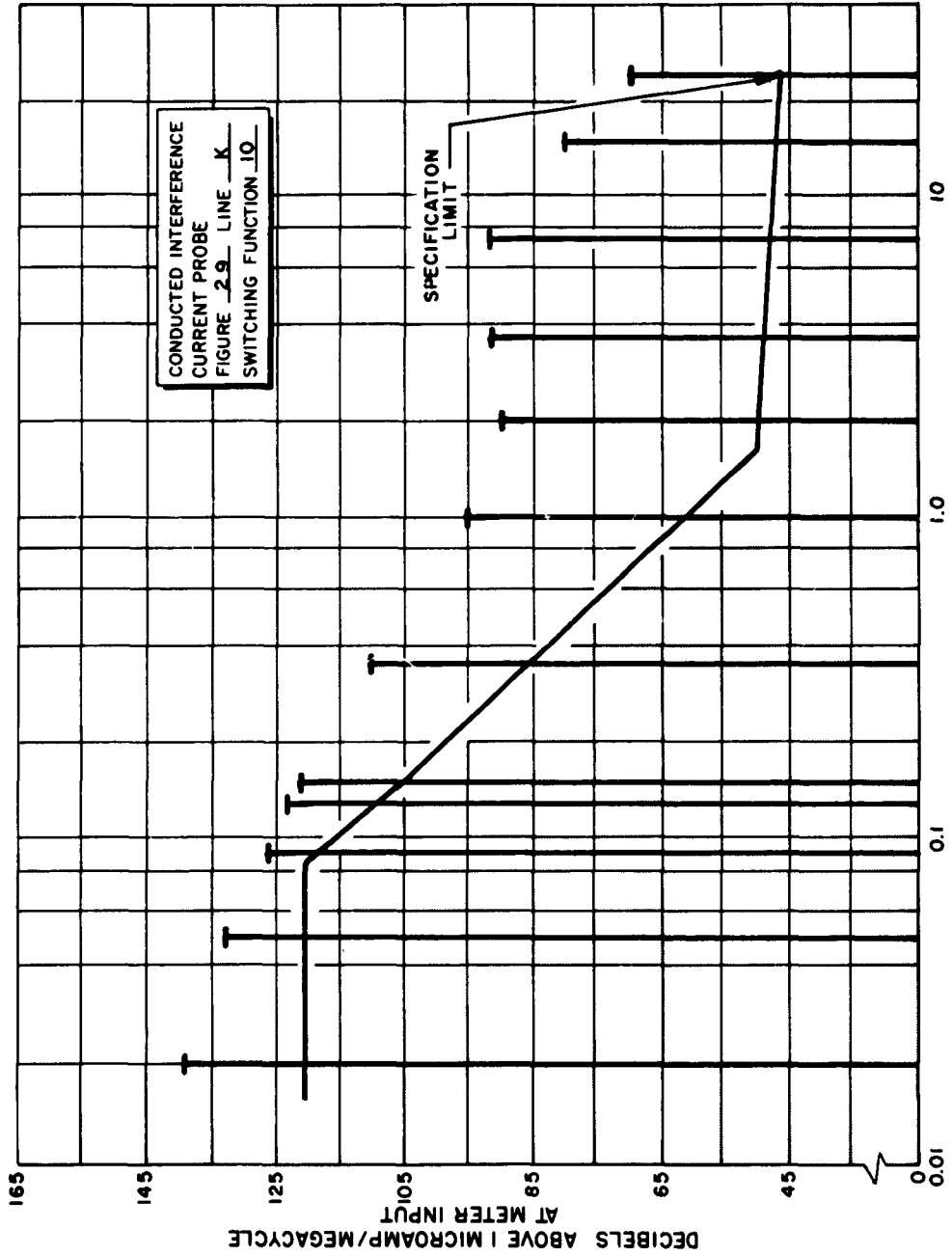

Figure 29. Line K, Switching Function 10 of Conducted Interference Current Probe

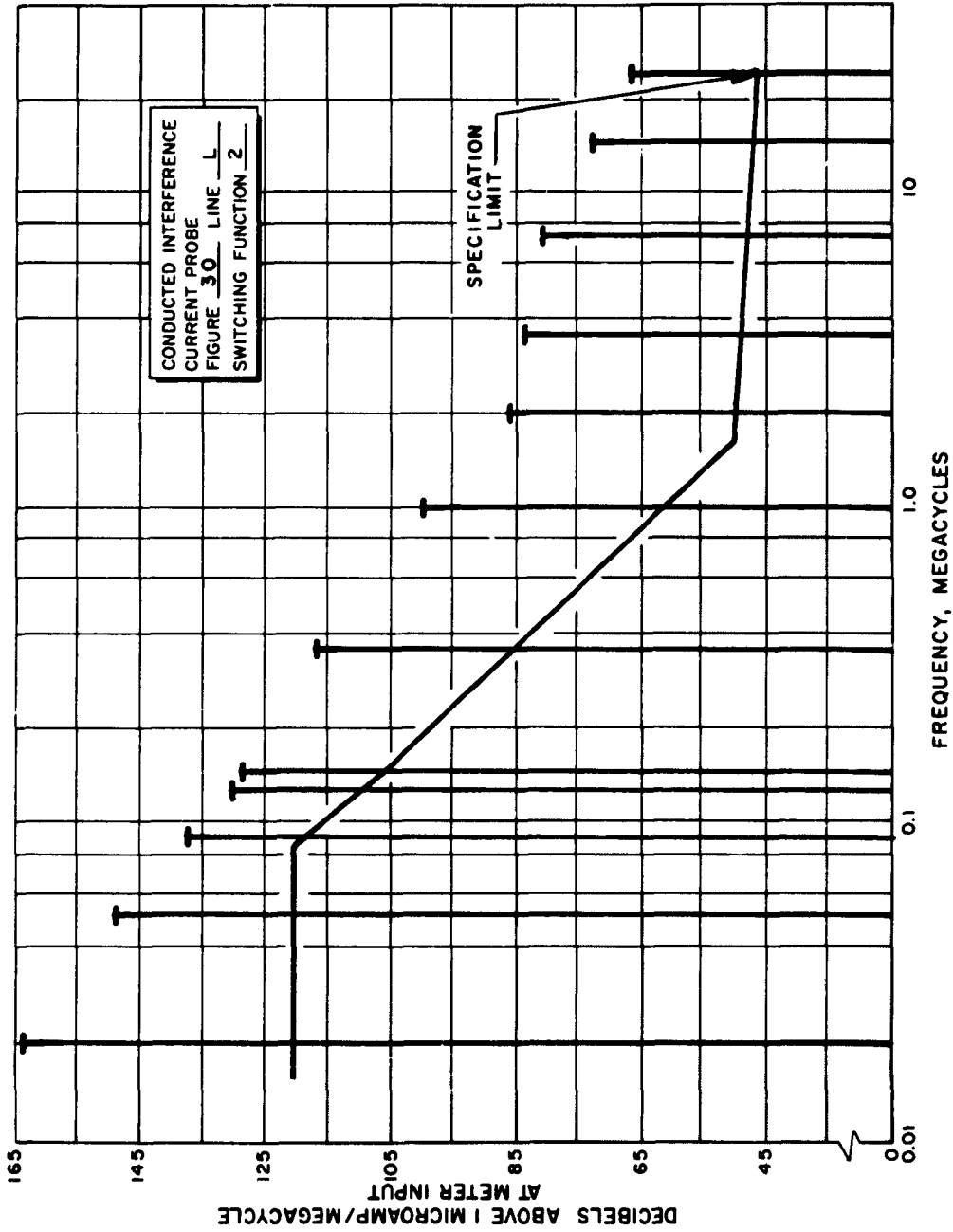

Figure 30. Line L, Switching Function 2 of Conducted Interference Current Probe

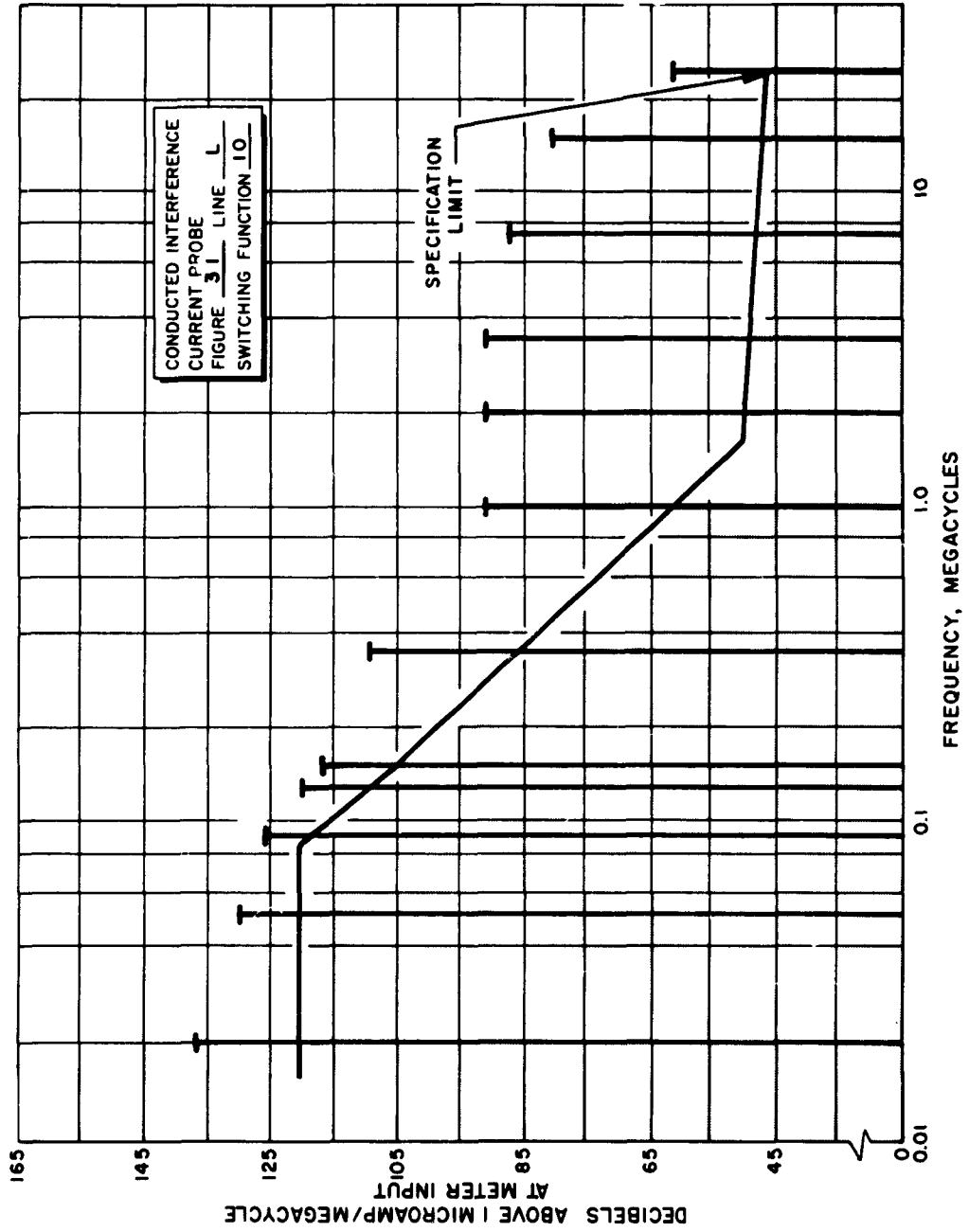

Figure 31. Line L, Switching Function 10 of Conducted Interference Current Probe



Figure 32. Line M, Switching Function 3 of Conducted Interference Current Probe

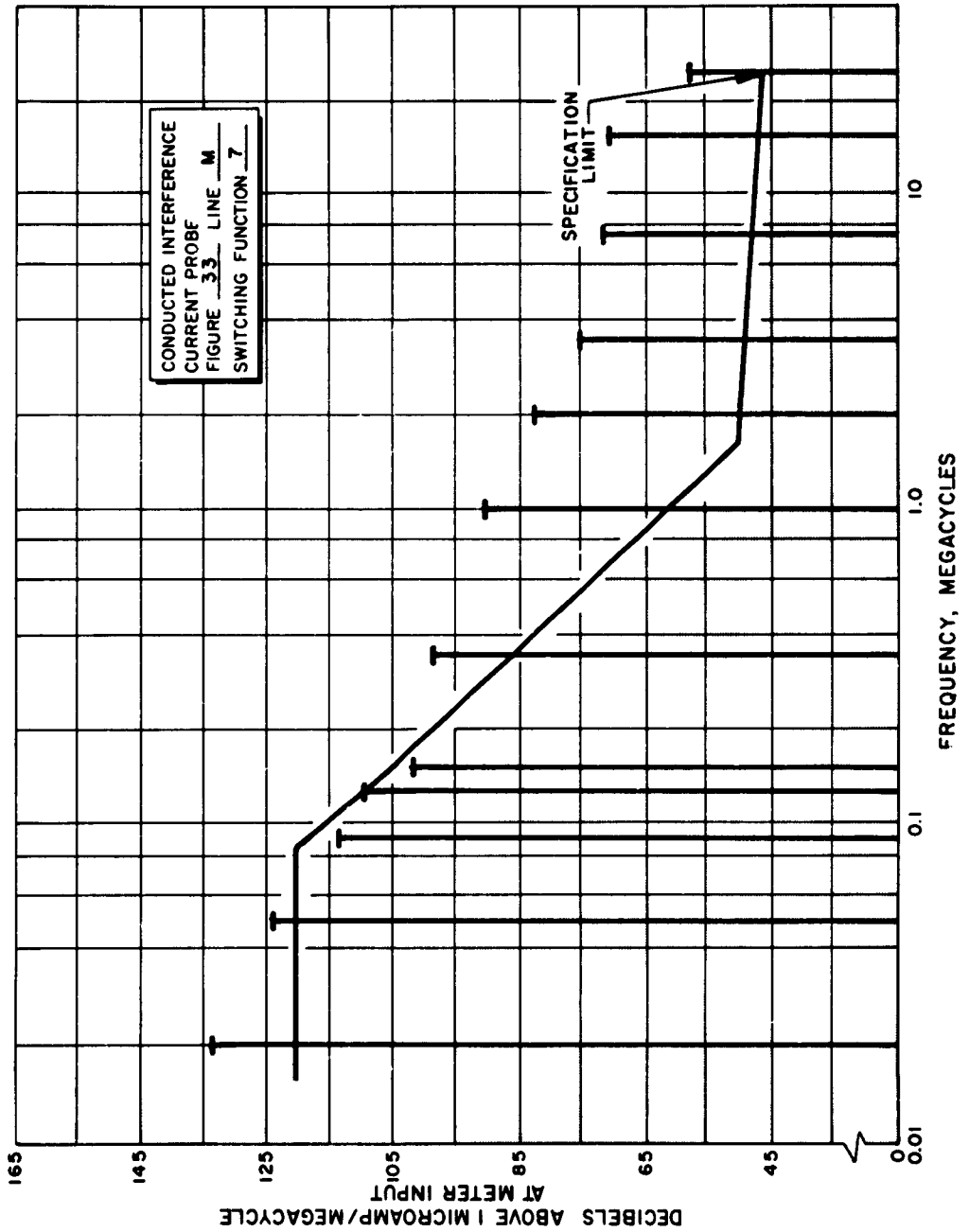

Figure 33 Line M, Switching Function 7 of Conducted Interference Current Probe

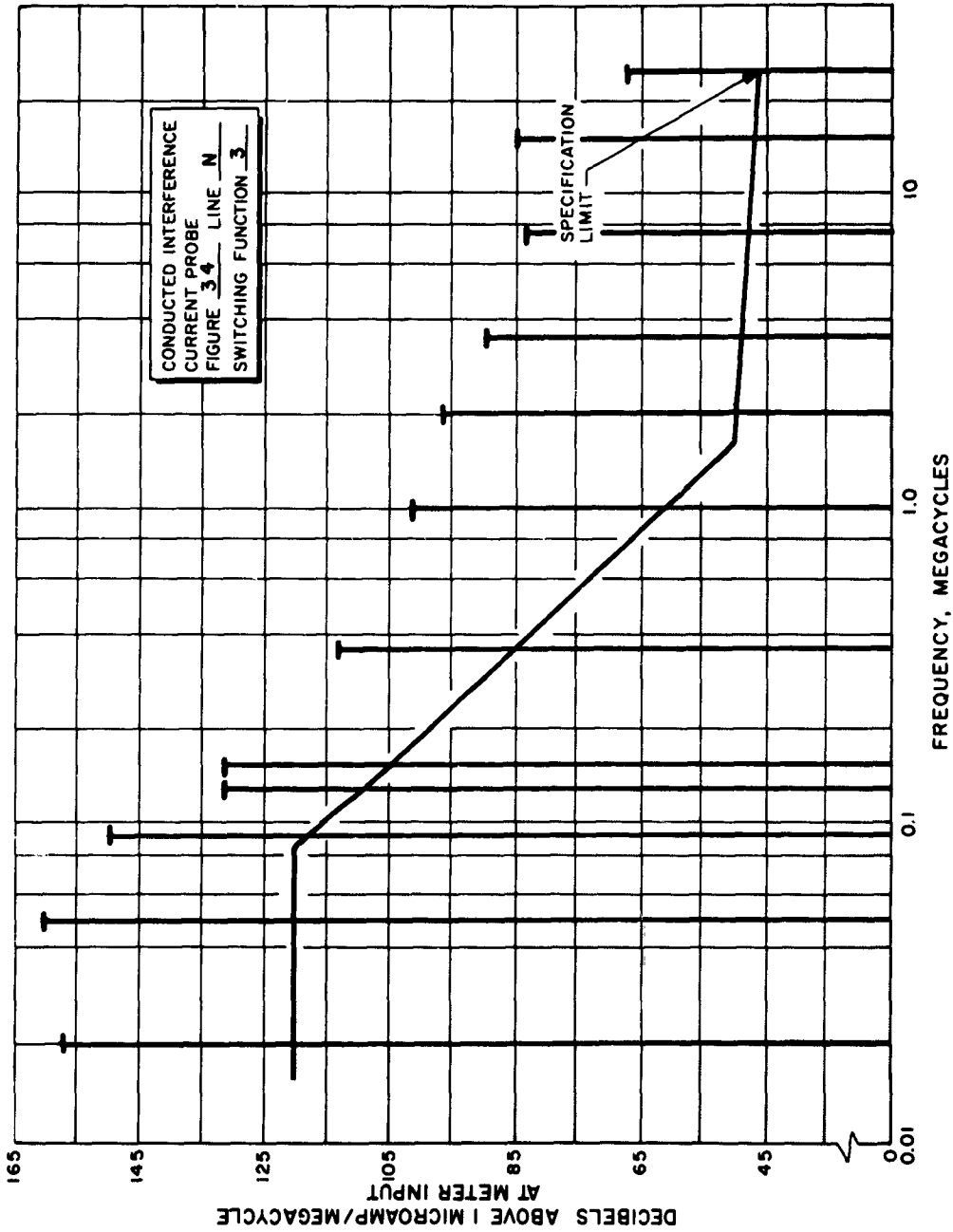

Figure 34. Line N, Switching Function 3 of Conducted Interference Current Probe

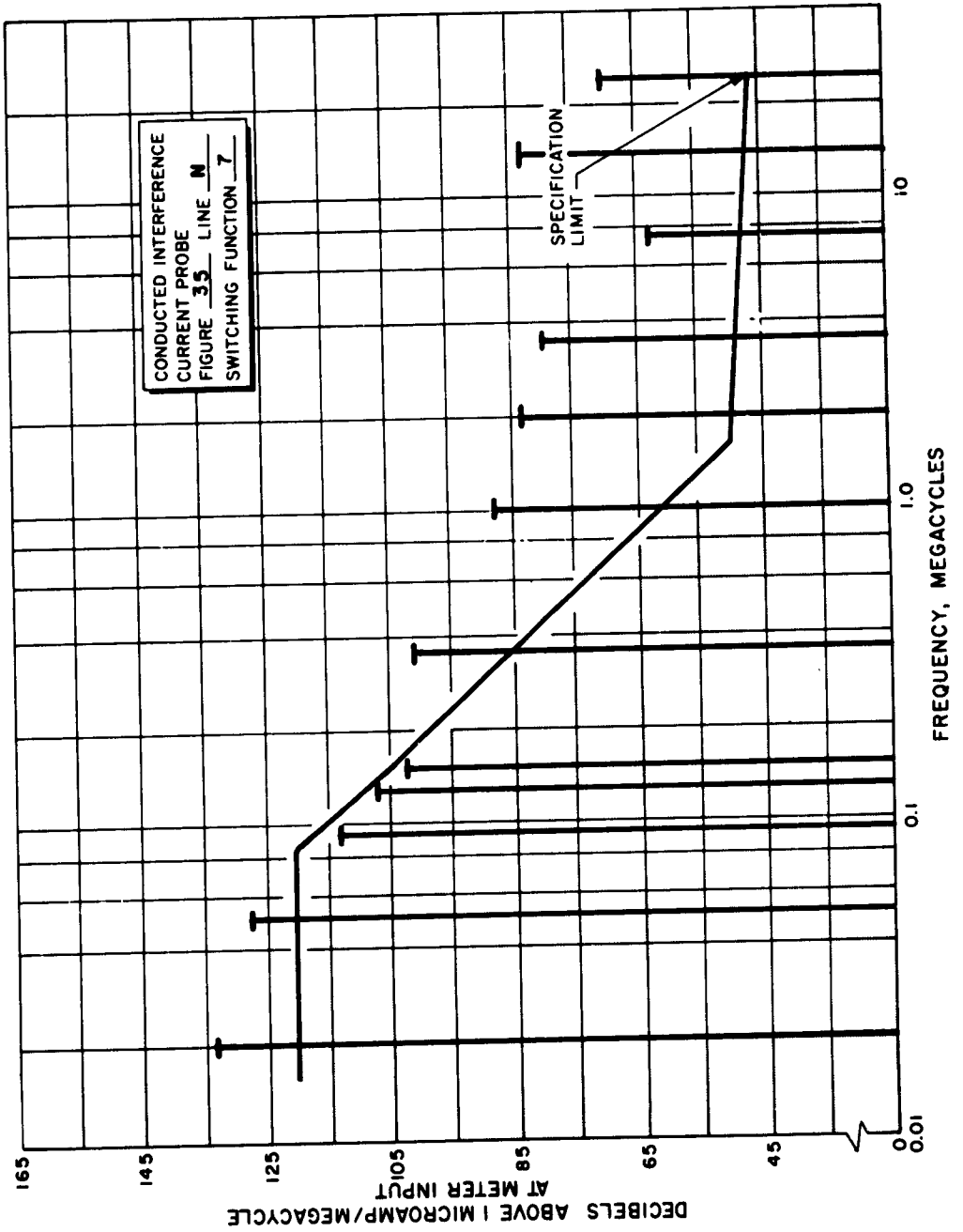

Figure 35. Line N, Switching Function 7 of Conducted Interference Current Probe

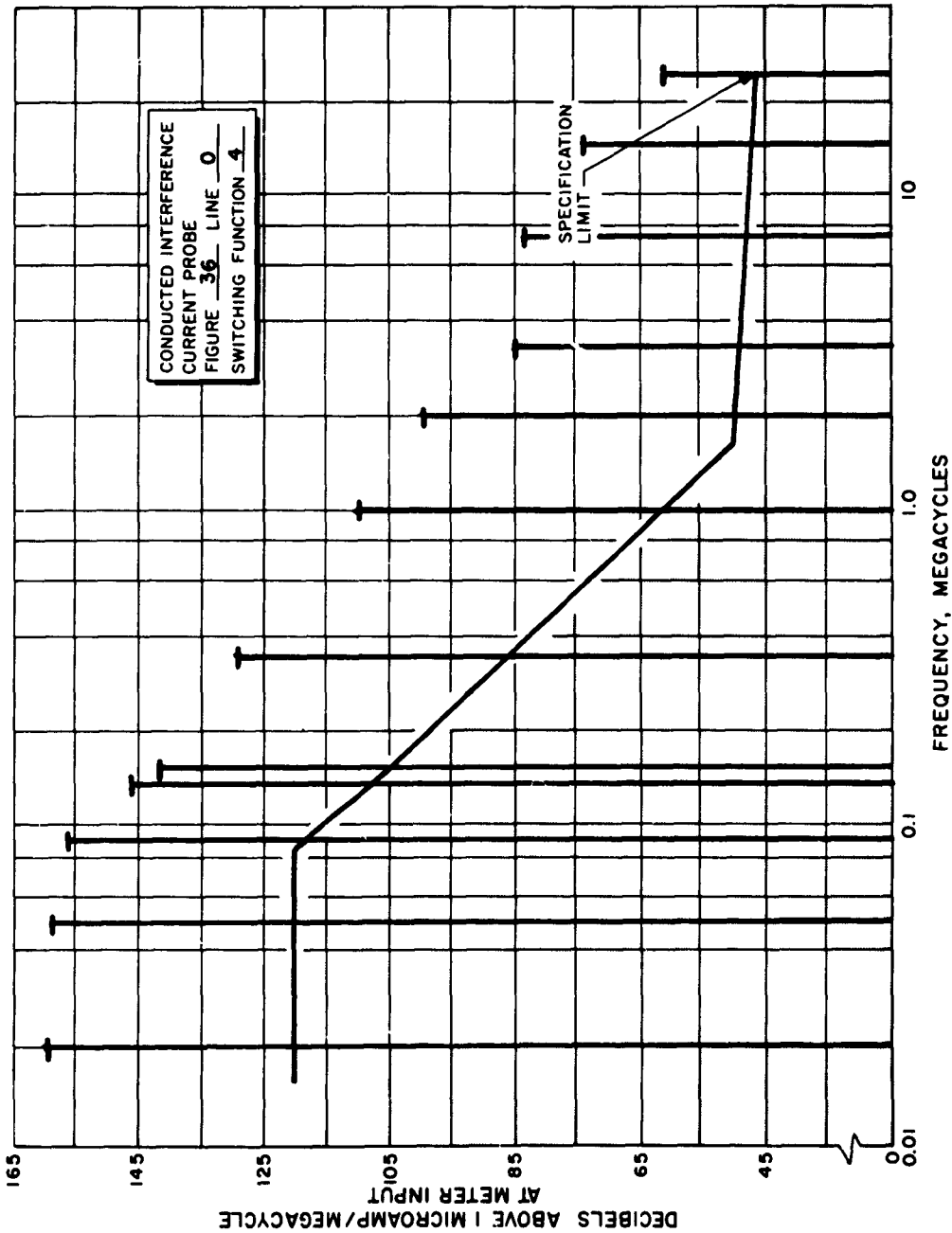

Figure 36. Line 0, Switching Function 4 of Conducted Interference Current Probe

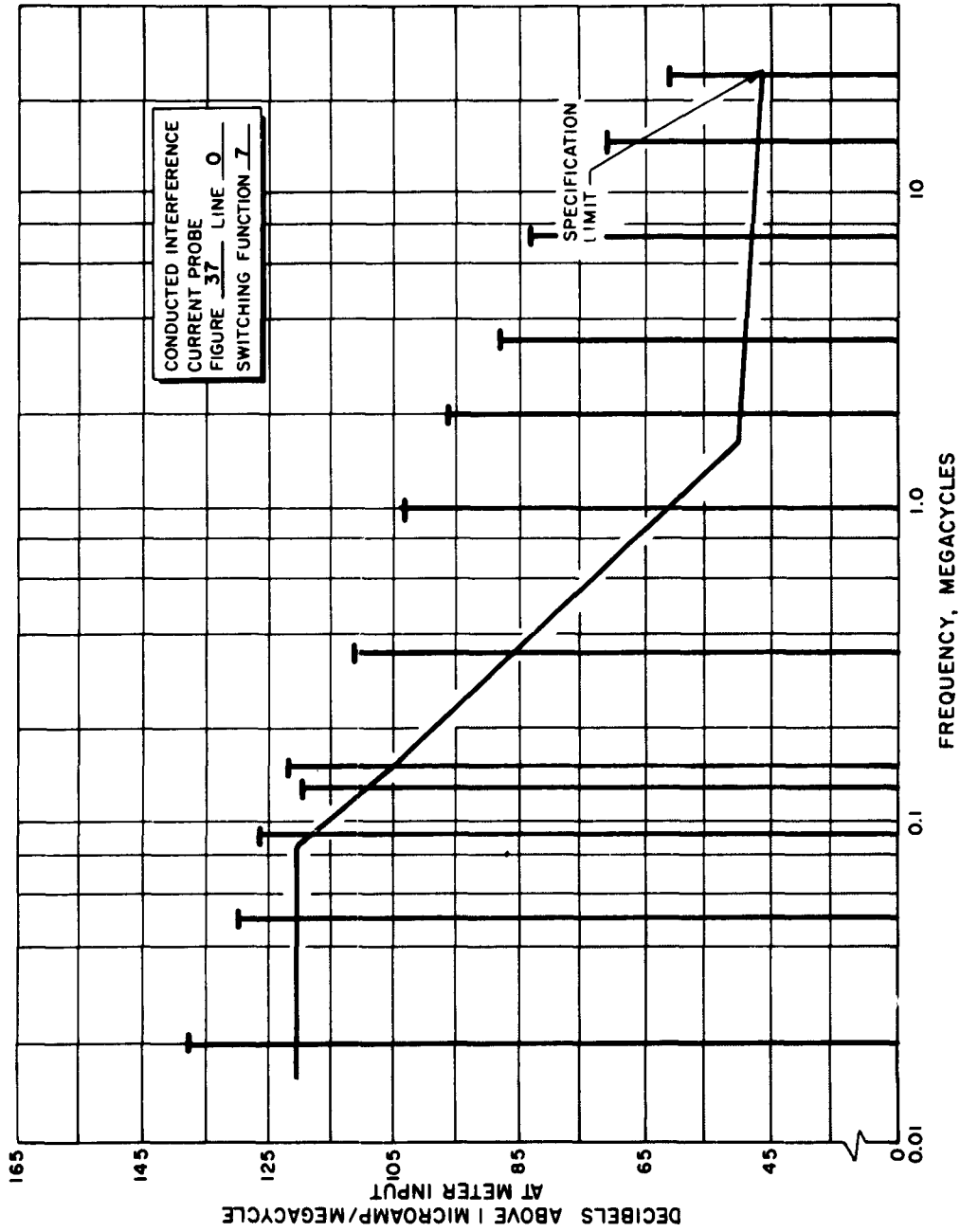

Figure 37. Line 0, Switching Function 7 of Conducted Interference Current Probe

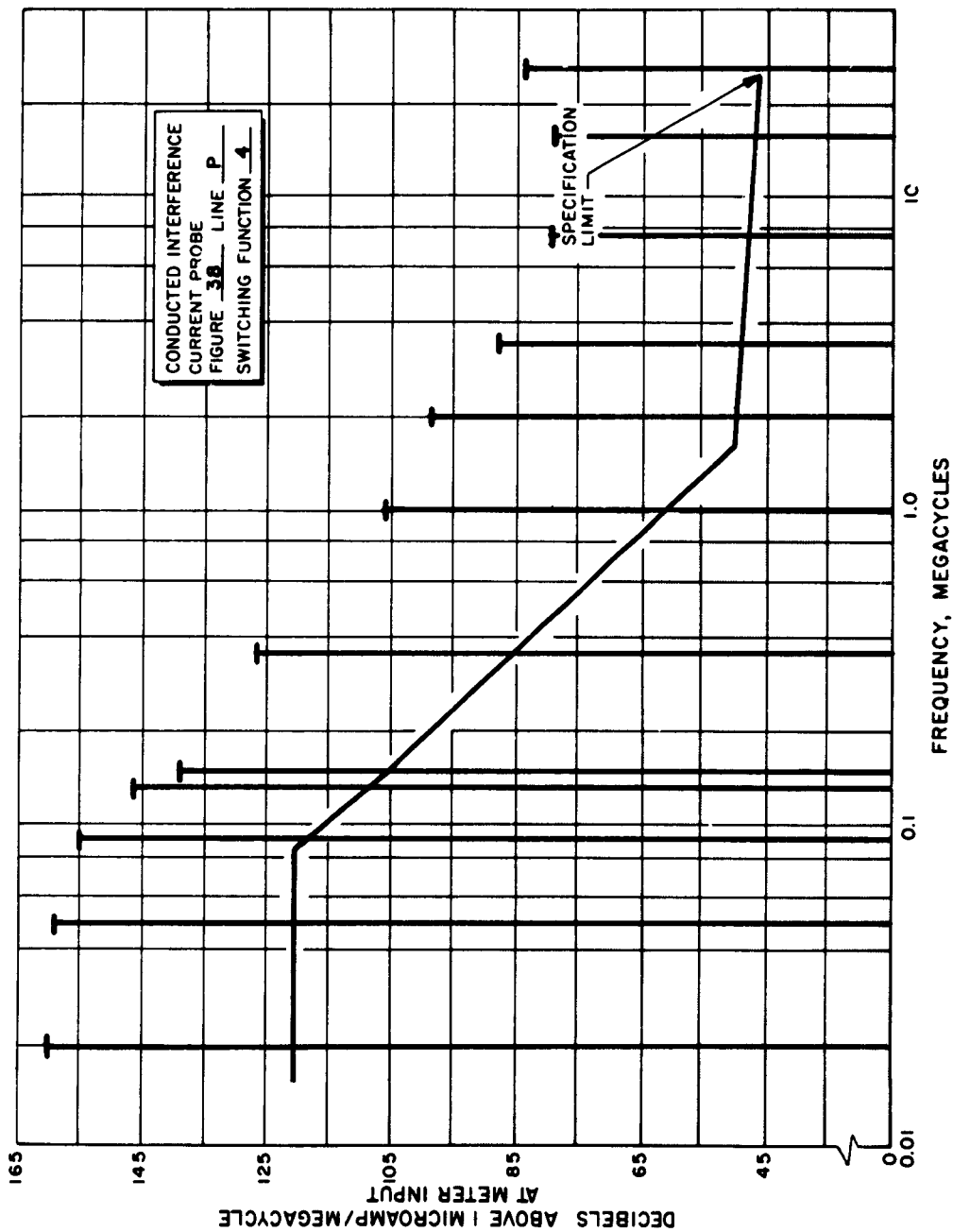

Figure 38. Line P, Switching Function 4 of Conducted Interference Current Probe

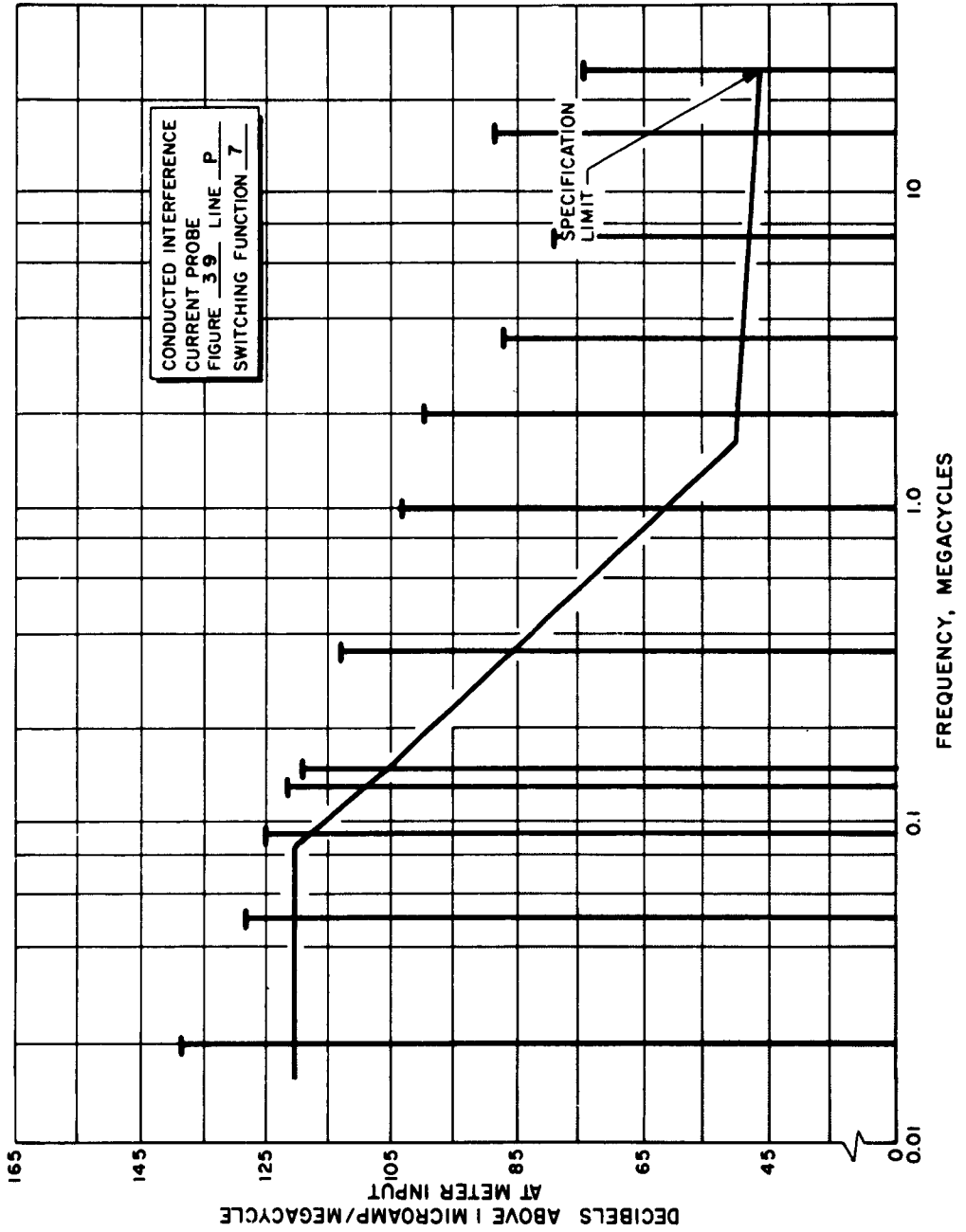

Figure 39. Line P, Switching Function 7 of Conducted Interference Current Probe

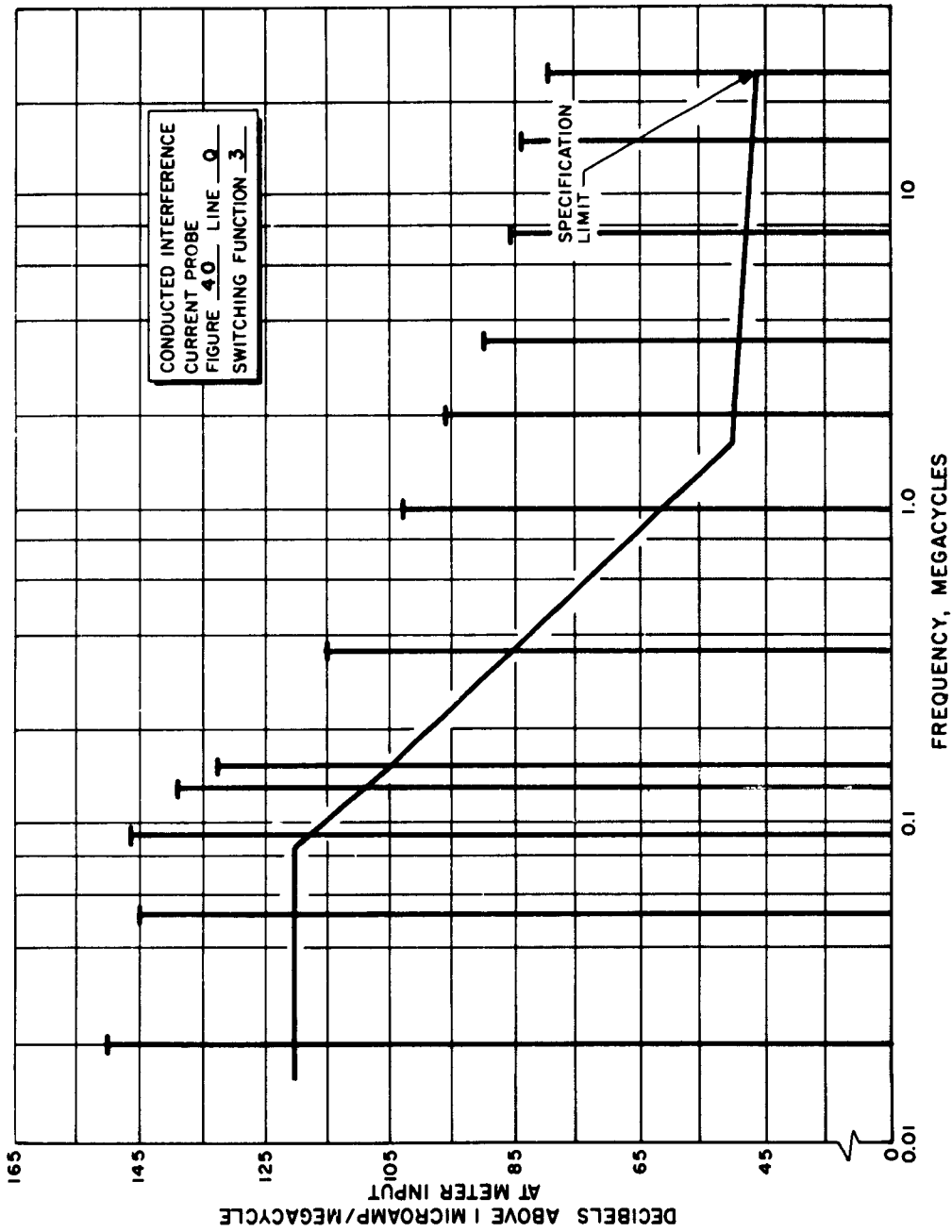

Figure 40. Line Q, Switching Function 3 of Conducted Interference Current Probe

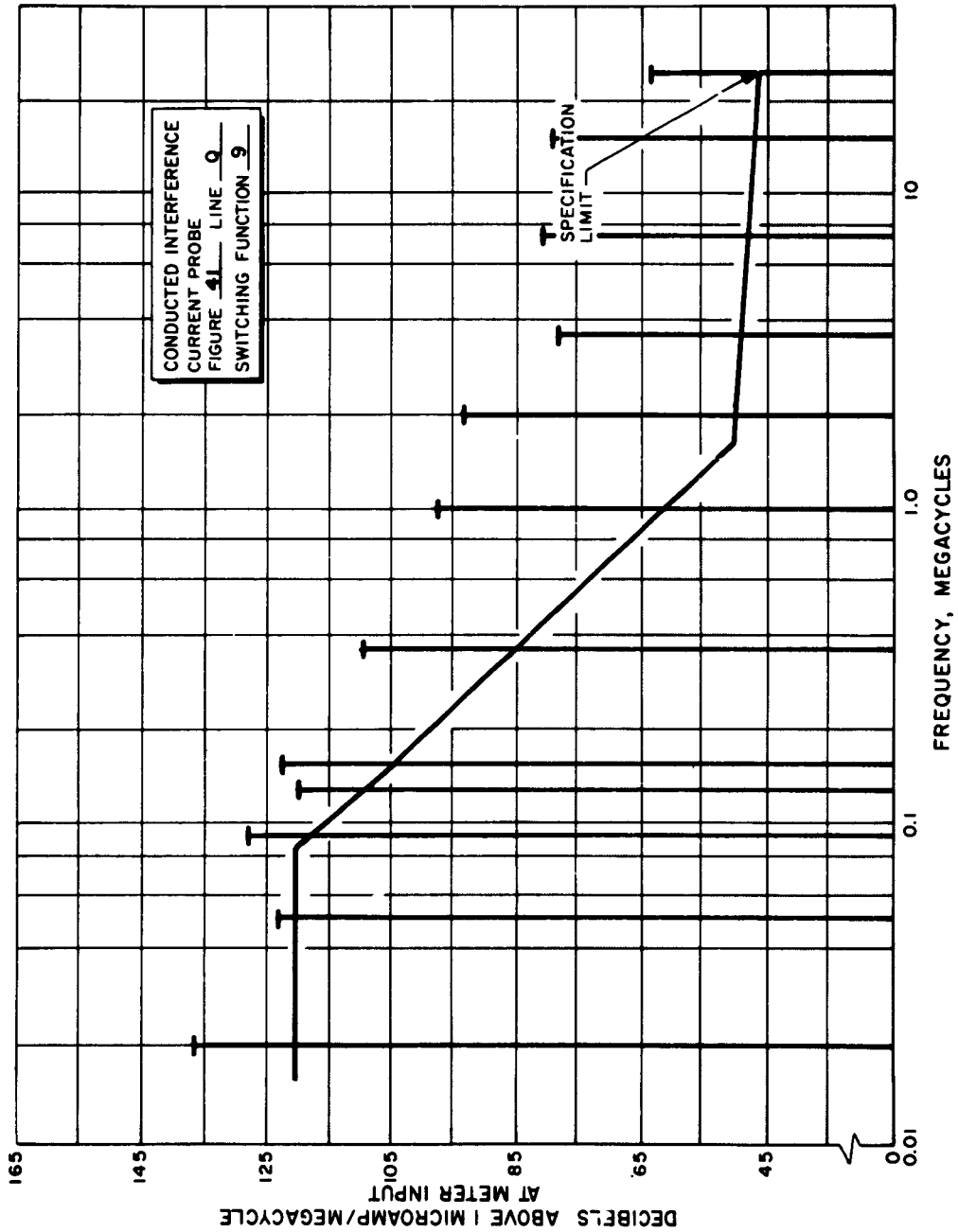

Figure 41. Line Q, Switching Function 9 of Conducted Interference Current Probe

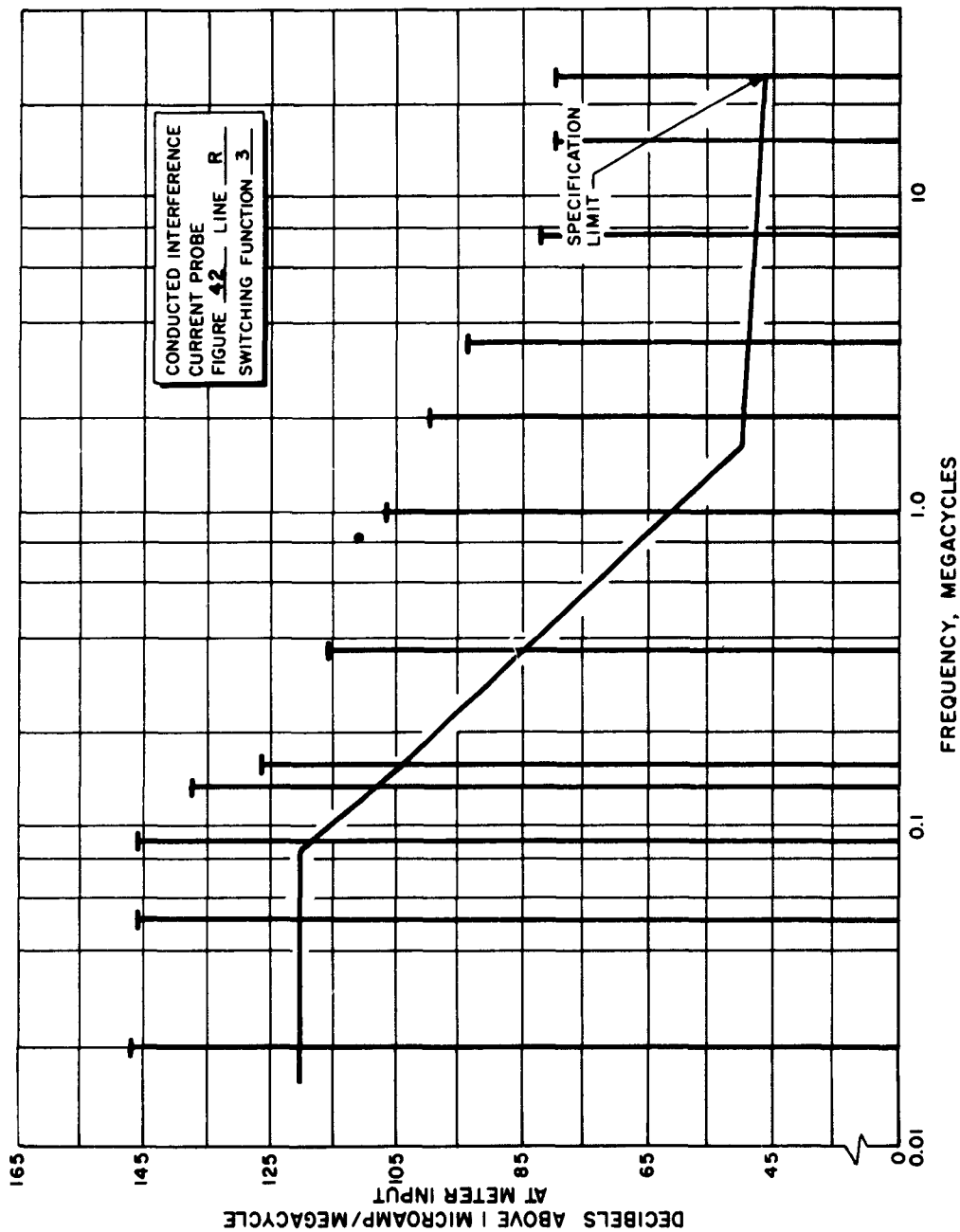

Figure 42. Line R, Switching Function 3 of Conducted Interference Current Probe

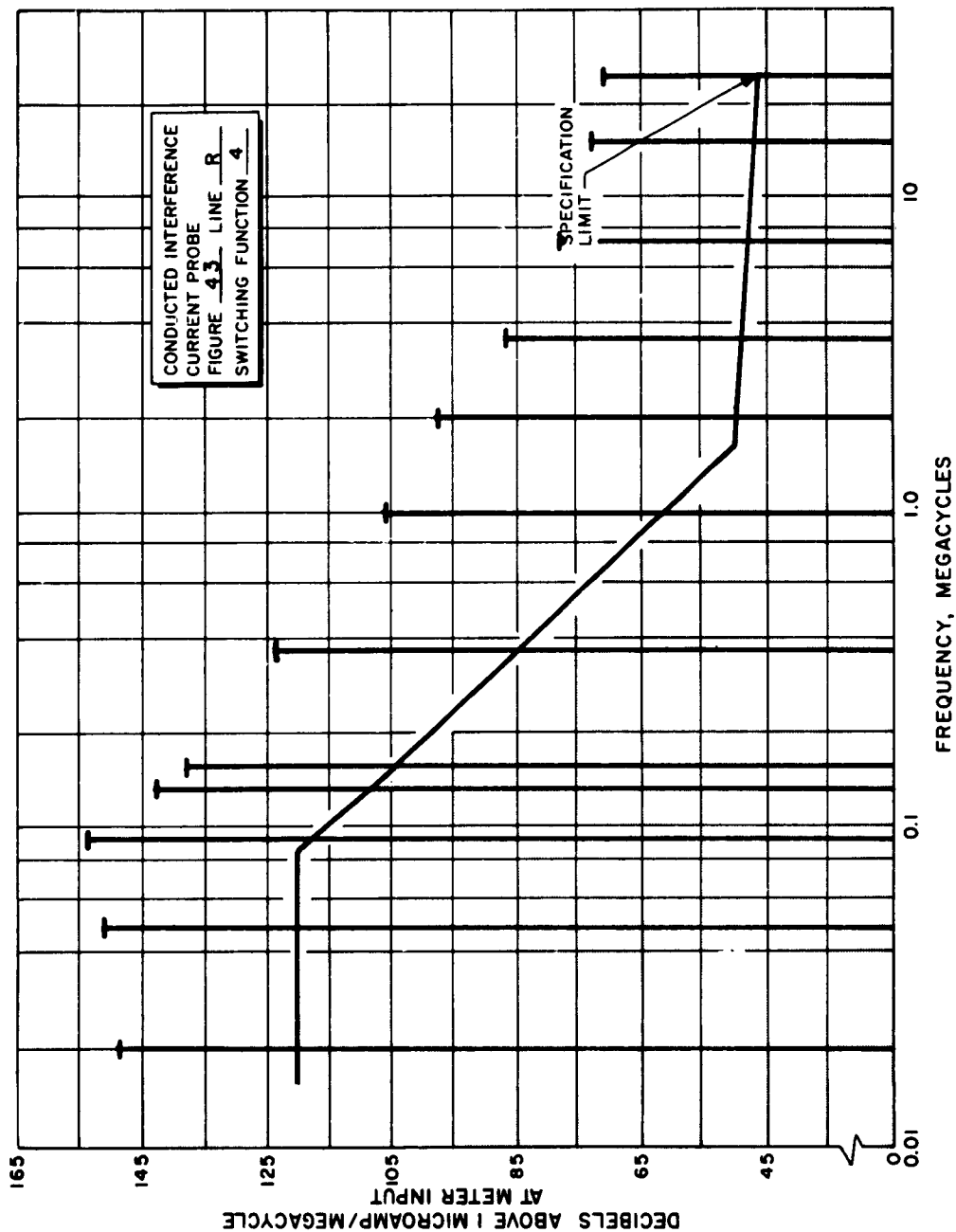

Figure 43. Line R, Switching Function 4 of Conducted Interference Current Probe

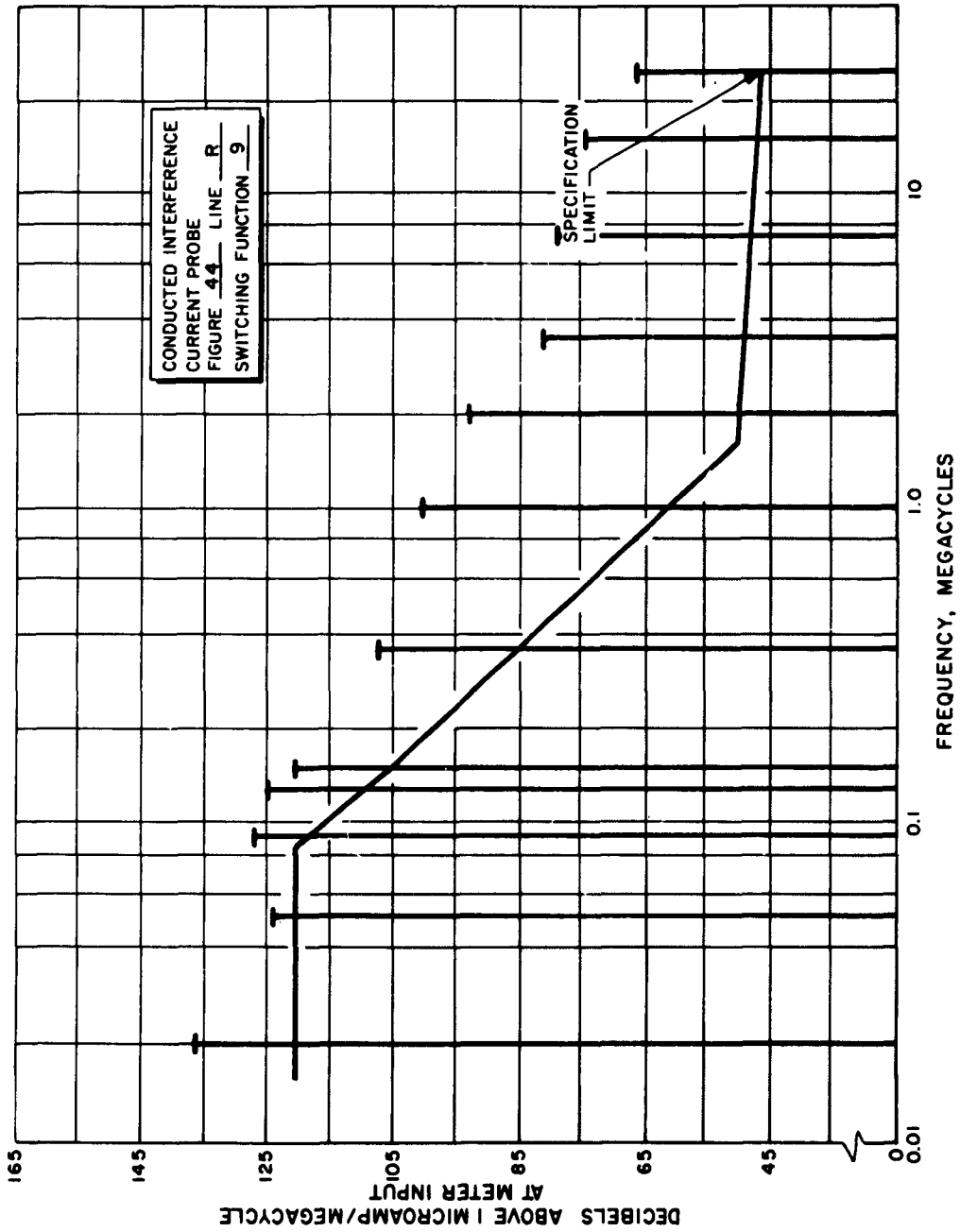

Figure 44. Line R, Switching Function 9 of Conducted Interference Current Probe

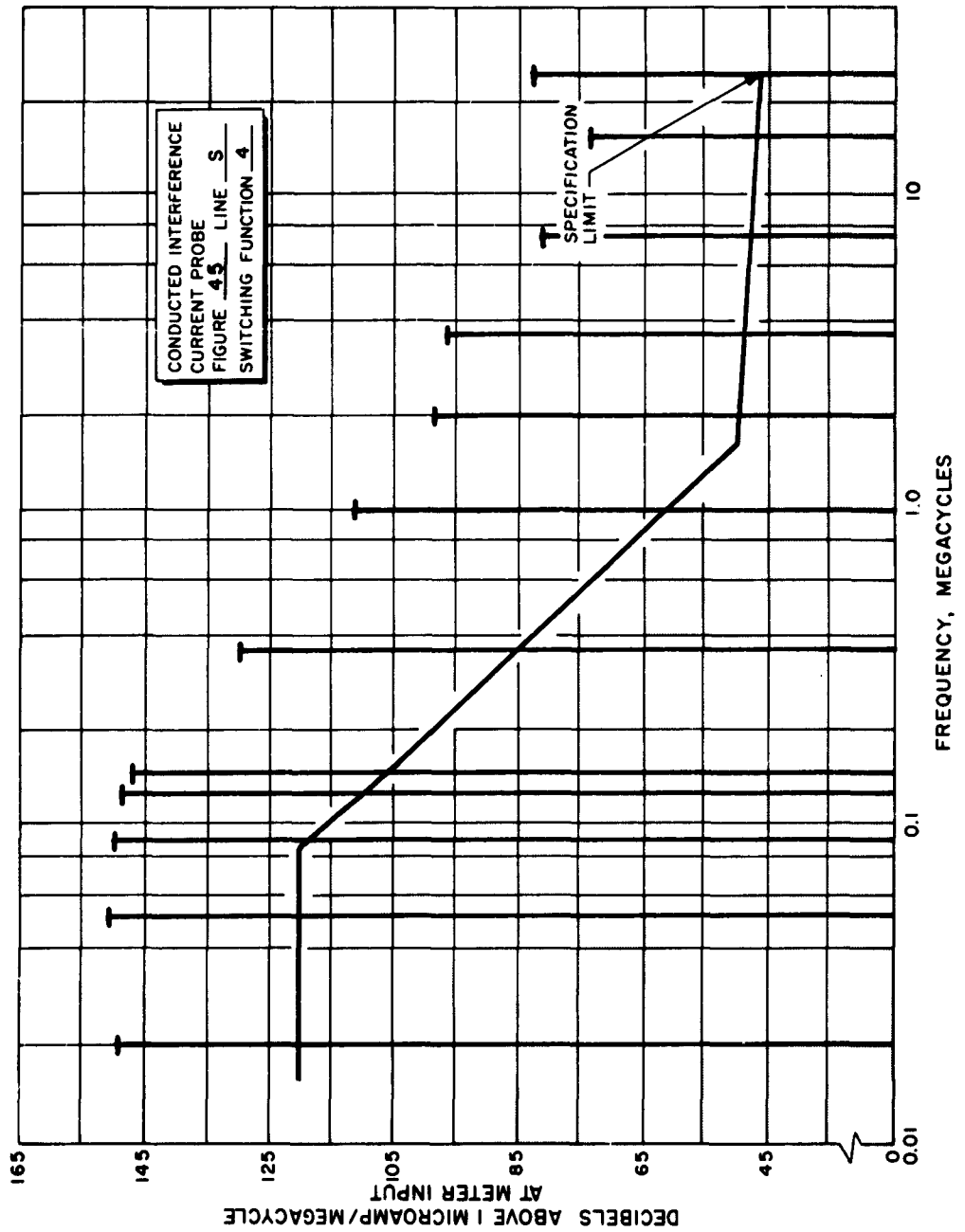

Figure 45. Line S, Switching Function 4 of Conducted Interference Current Probe

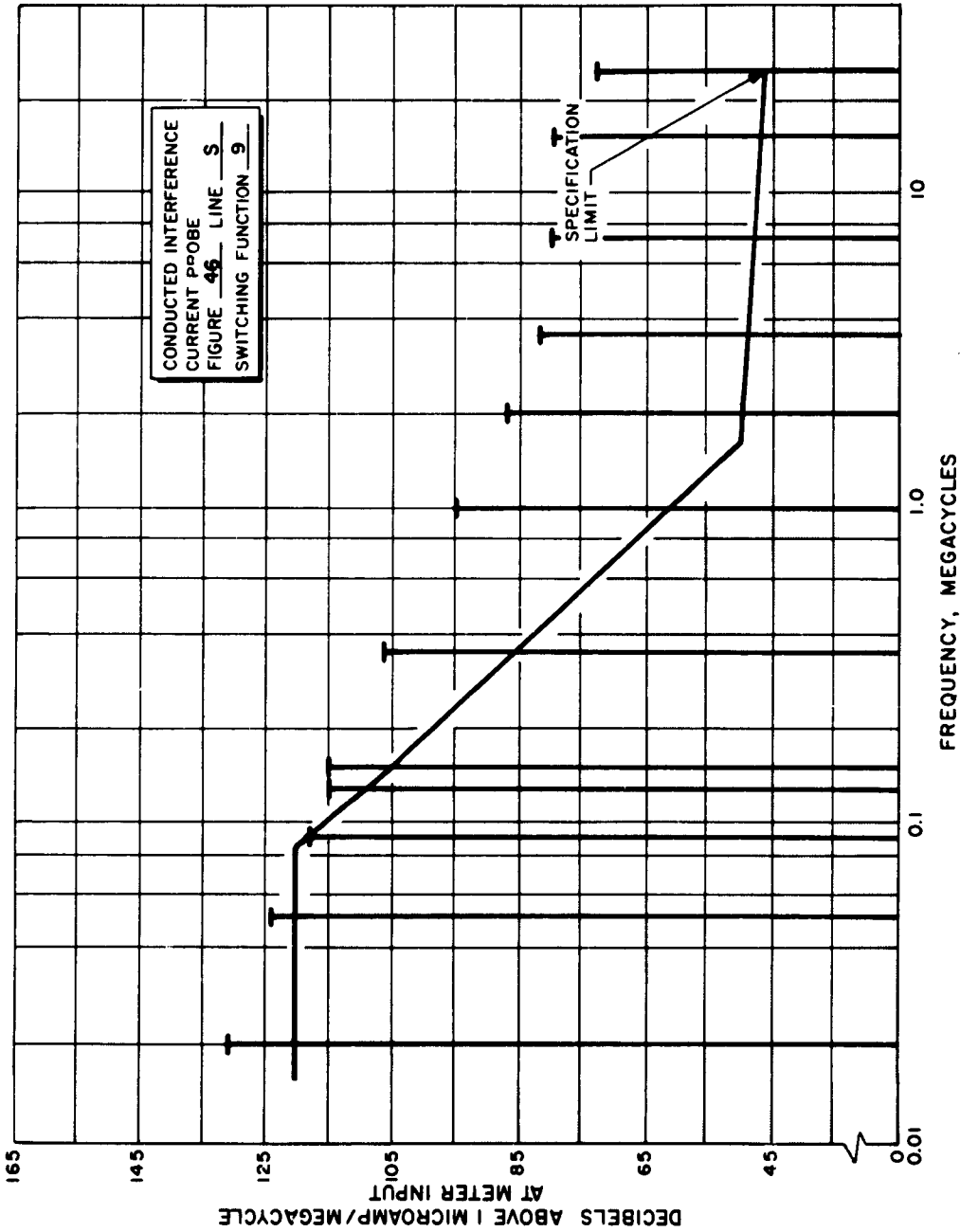

Figure 46. Line S, Switching Function 9 of Conducted Interference Current Probe

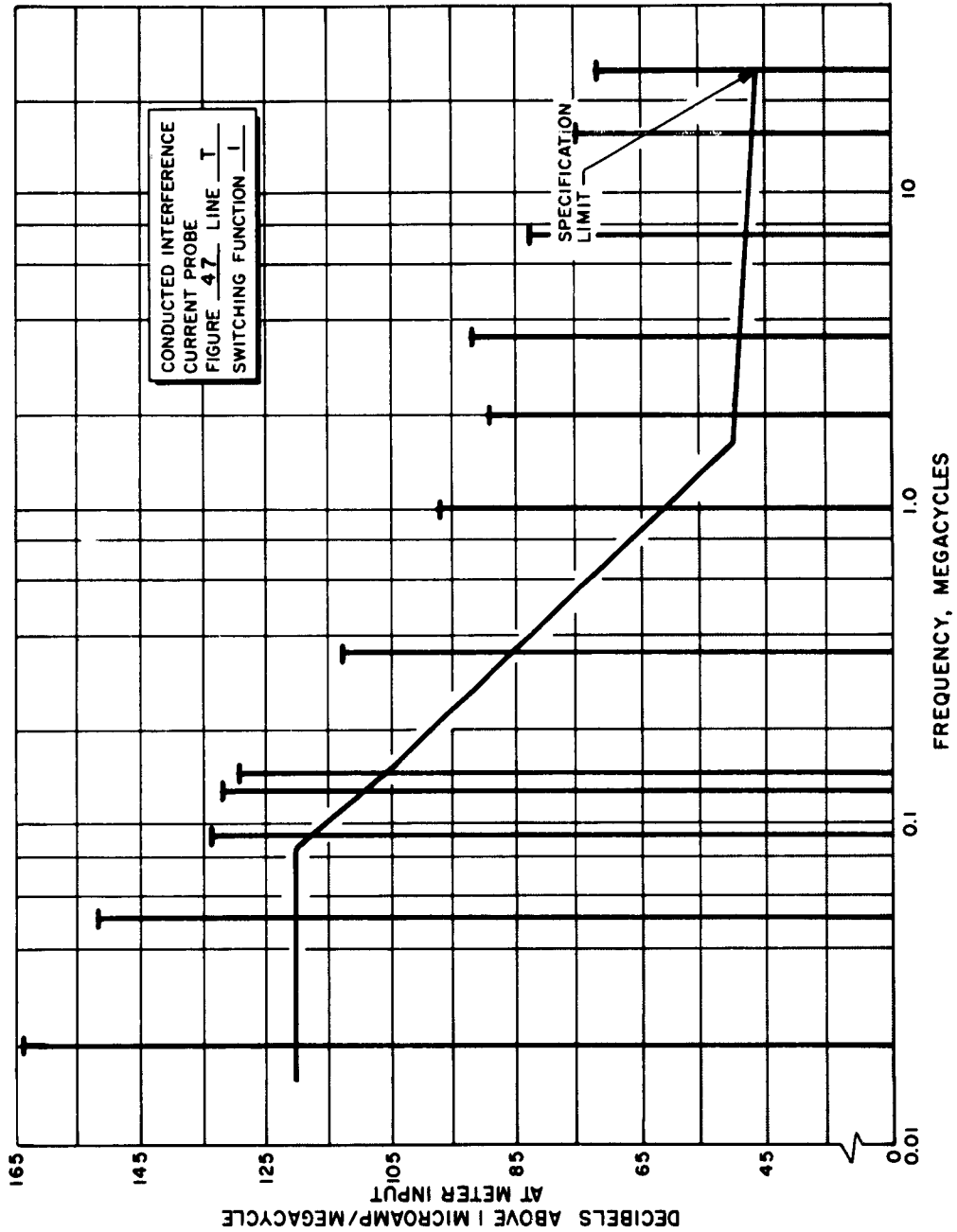

Figure 47. Line T, Switching Function 1 of Conducted Interference Current Probe

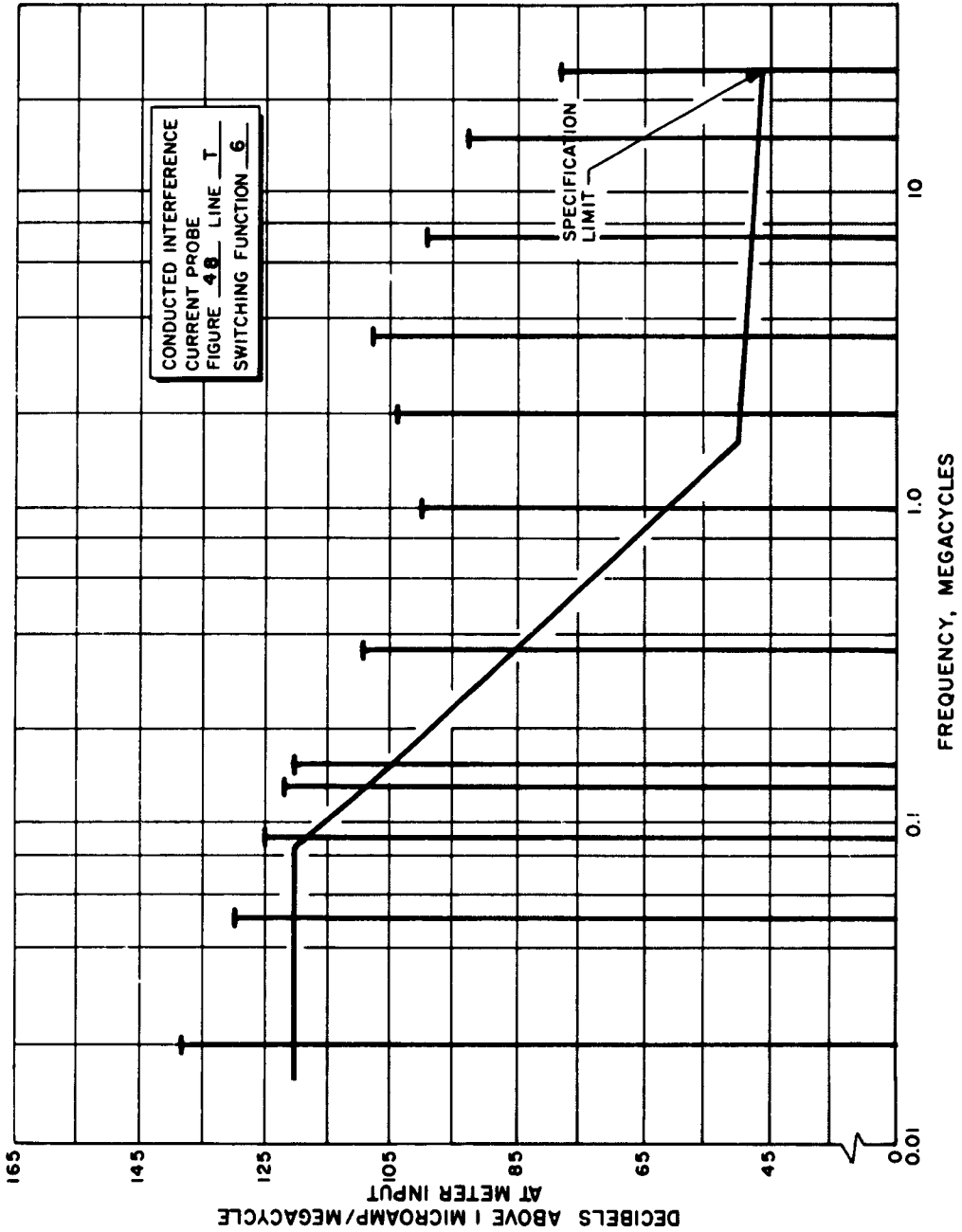

Figure 48. Line T, Switching Function 6 of Conducted Interference Current Probe

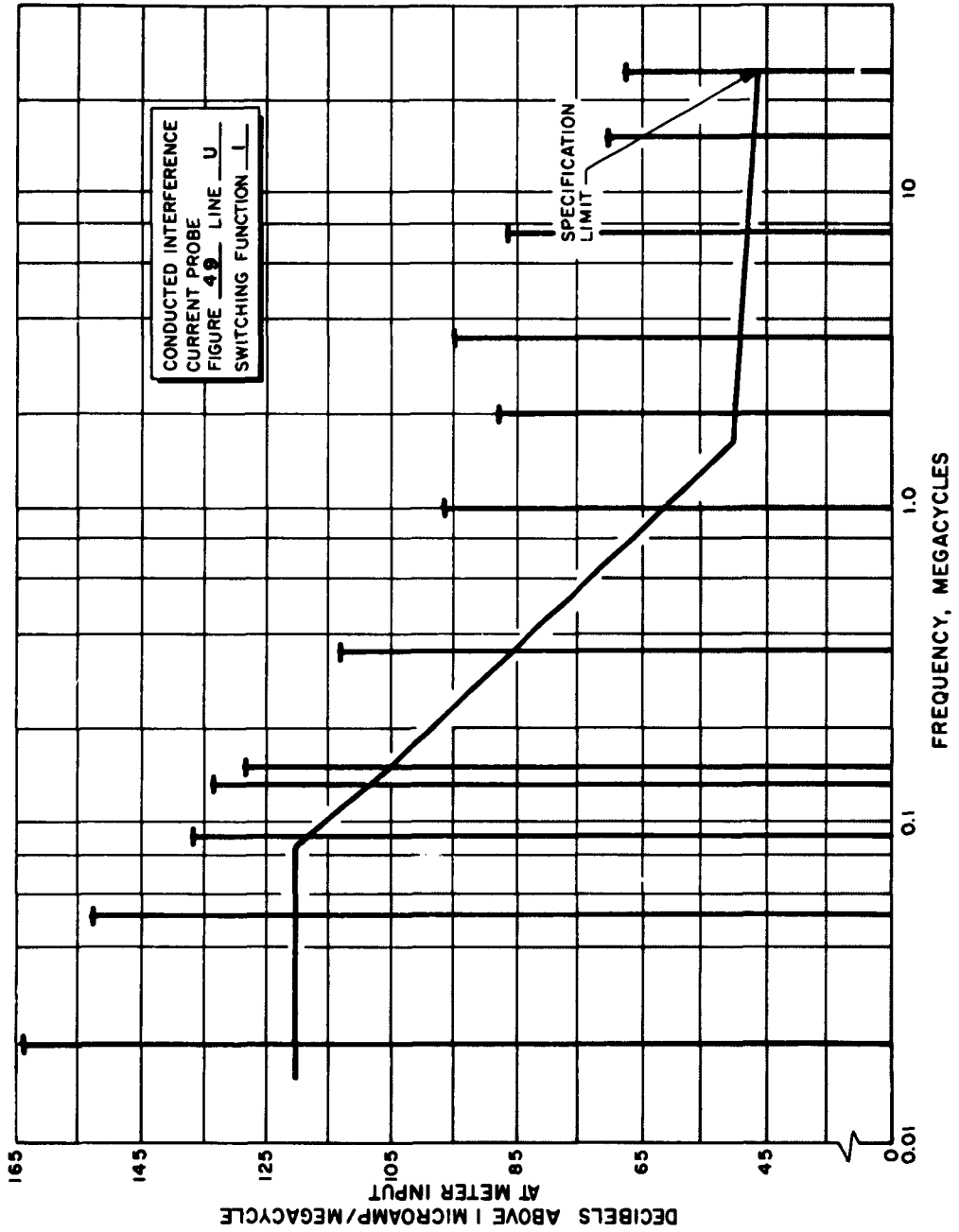

Figure 49. Line U, Switching Function I of Conducted Interference Current Probe

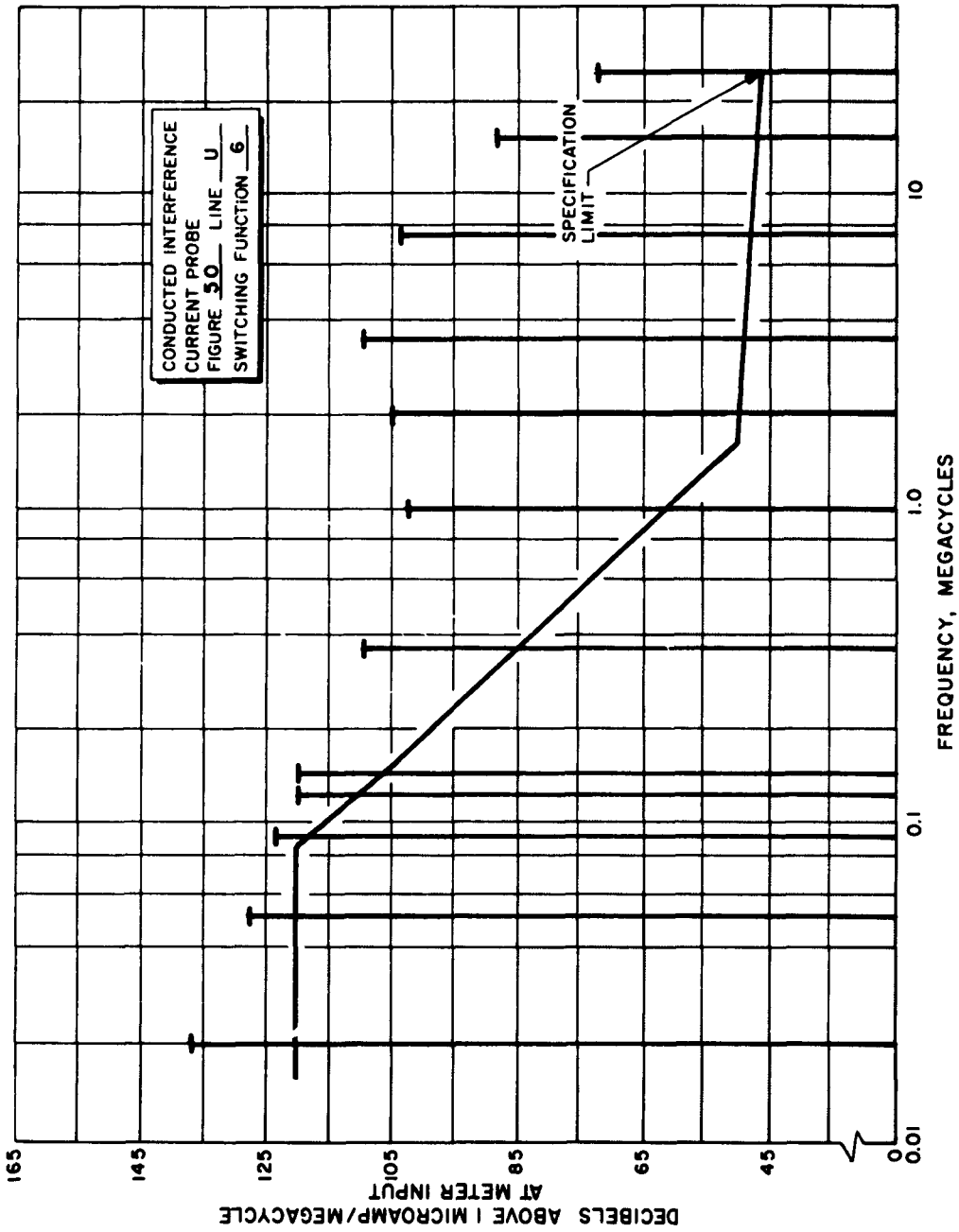

Figure 50. Line U, Switching Function 6 of Conducted Interference Current Probe

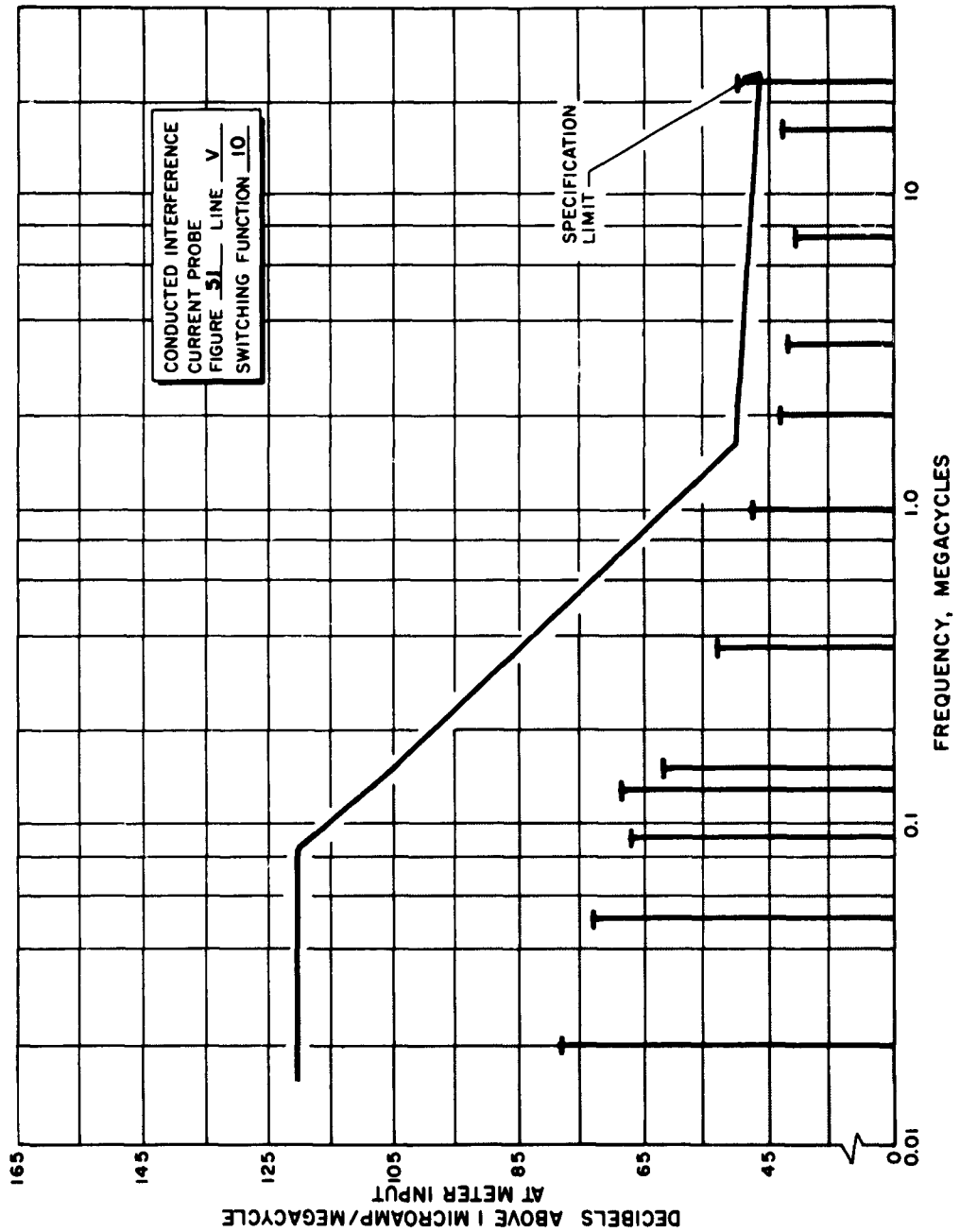

Figure 51. Line V, Switching Function 10 of Conducted Interference Current Probe

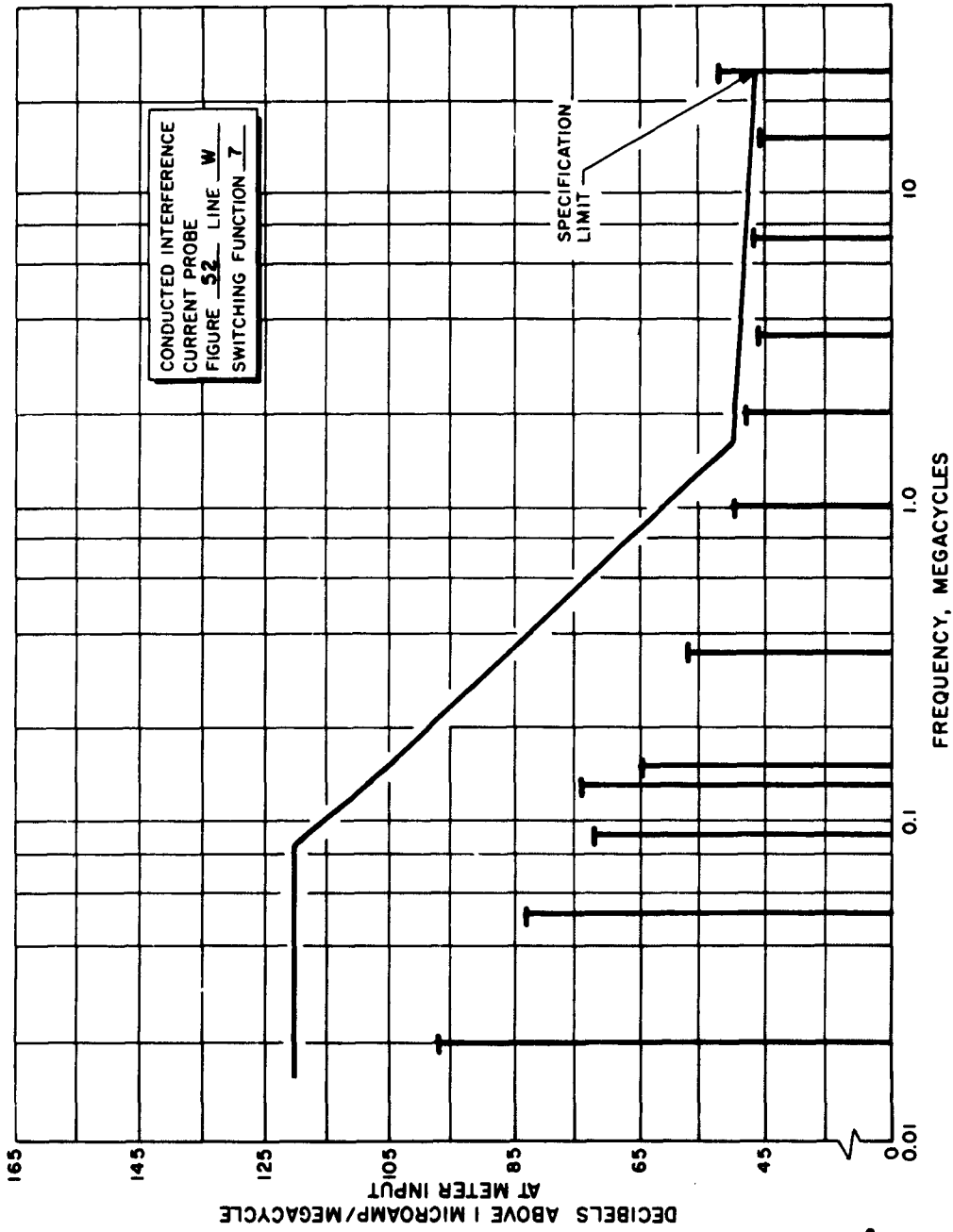

Figure 52. Line W, Switching Function 7 of Conducted Interference Current Probe

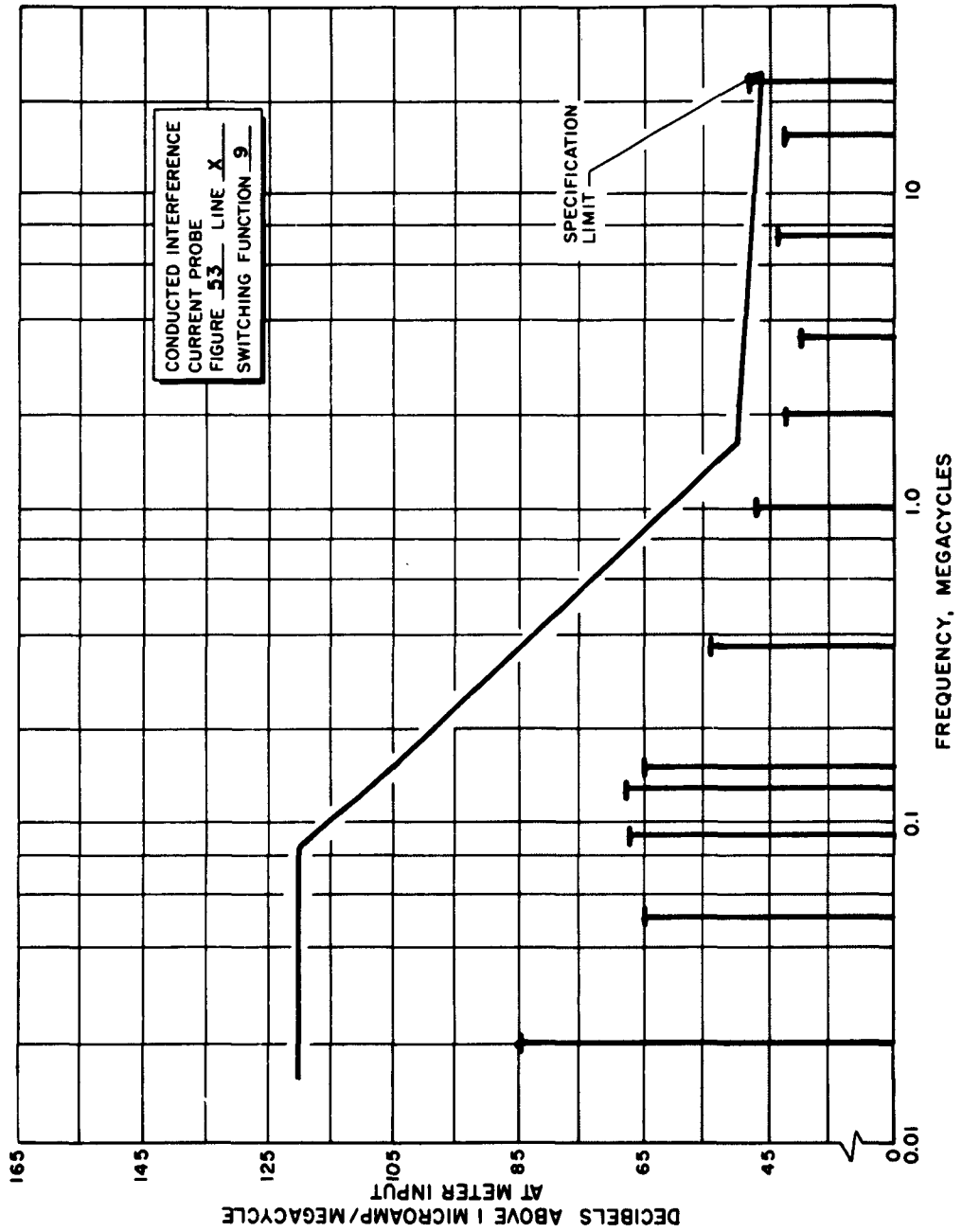

Figure 53. Line X, Switching Function 9 of Conducted Interference Current Probe

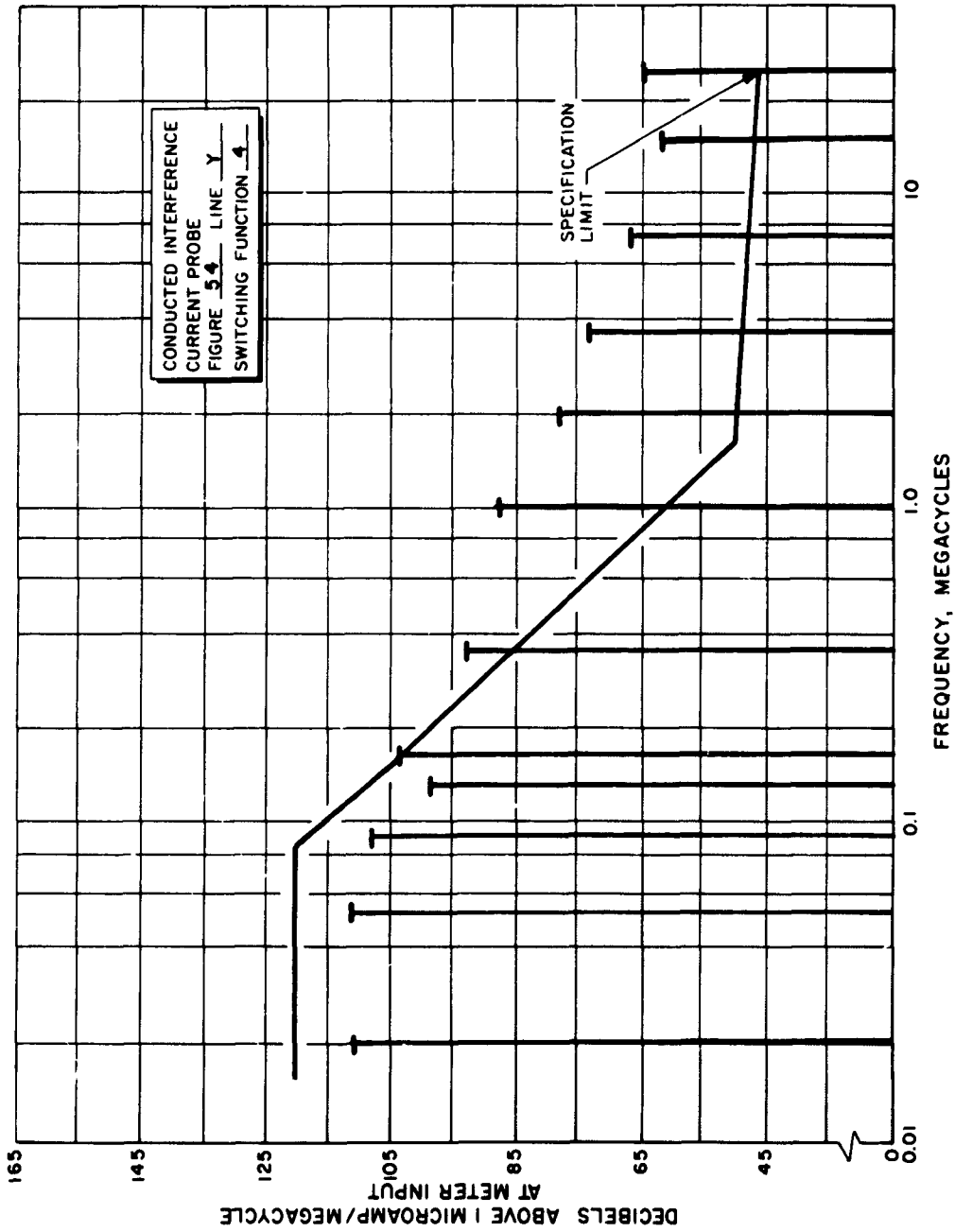

Figure 54. Line Y, Switching Function 4 of Conducted Interference Current Probe

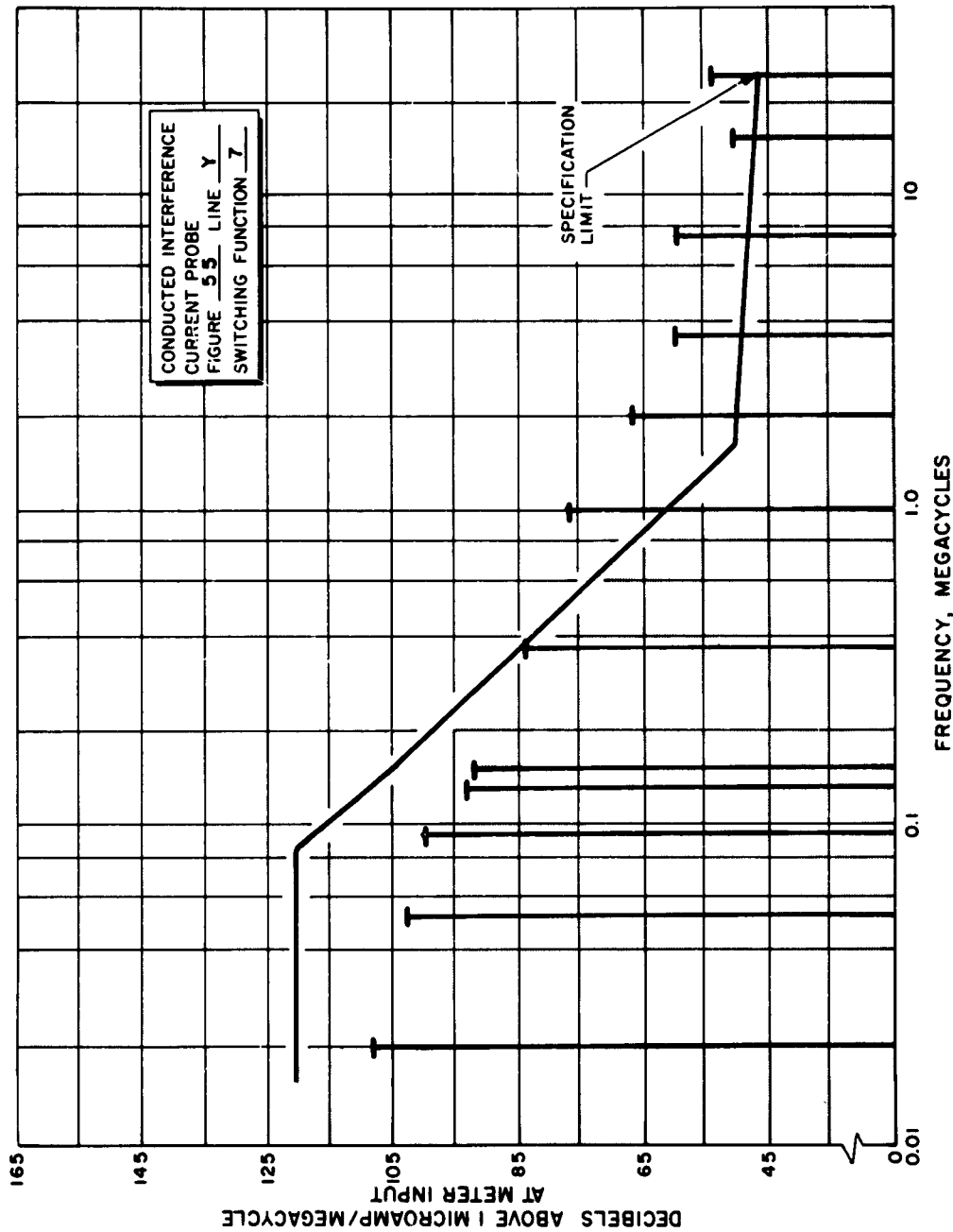

Figure 55 Line Y, Switching Function 7 of Conducted Interference Current Probe

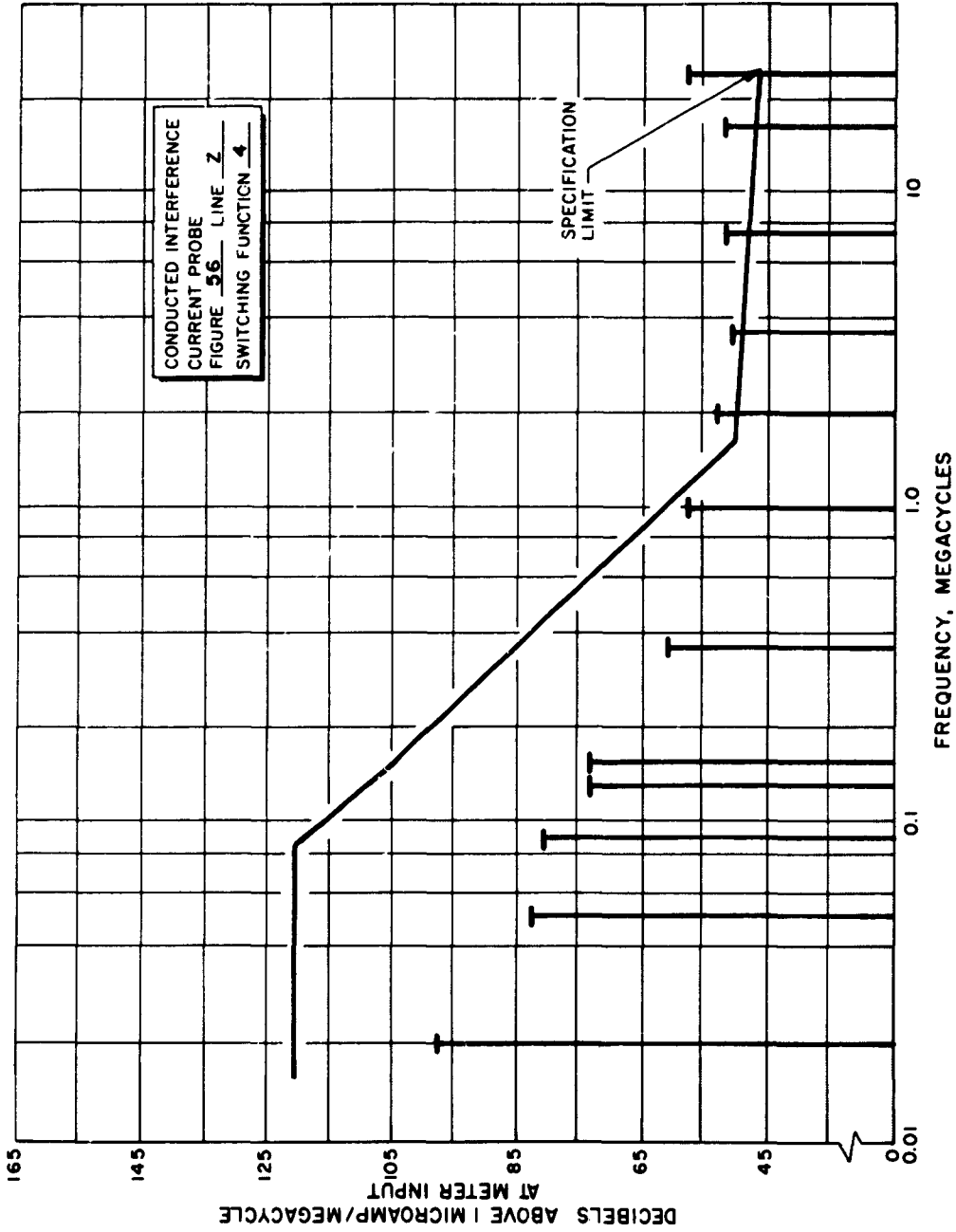

Figure 56. Line Z, Switching Function 4 of Conducted Interference Current Probe

APPENDIX D

RADIATED INTERFERENCE MEASUREMENTS

Table 5 and Fig. 57 through 64 present radiated interference measurements (paragraph 3.5.1.2 of STL document 6201-0004-NU-000).

TABLE 5

RADIATED INTERFERENCE TEST*

Frequency, megacycles	Function							
	1	2	3	4	6	7	9	10
0.230	67	66	60	67	**	59	61	63
0.400	60	58	54	59	**	55	57	58
0.800	60	58	50	56	**	54	58	56
1.4	70	67	65	67	42	70	69	68
2.7	79	75	81	75	53	76	74	73
6	62	62	55	57	57	64	52	66
14	69	70	71	72	42	70	72	73
27	68	57	55	72	41	63	69	71
60	64	66	67	67	66	68	62	60
104	57	54	53	54	53	56	54	62
280	35	31	26	39	29	31	32	40
380	38	37	**	**	**	**	**	**
0.020	100	99	93	97	70	92	94	96
0.050	86	74	64	88	**	64	66	71
0.090	70	72	62	66	**	59	**	58
0.140	62	65	51	55	**	56	**	58

*Units given in decibels above 1 μ volt/megacycle (antenna-induced, no correction factors added)

**Readings were below the noise level of the receiver

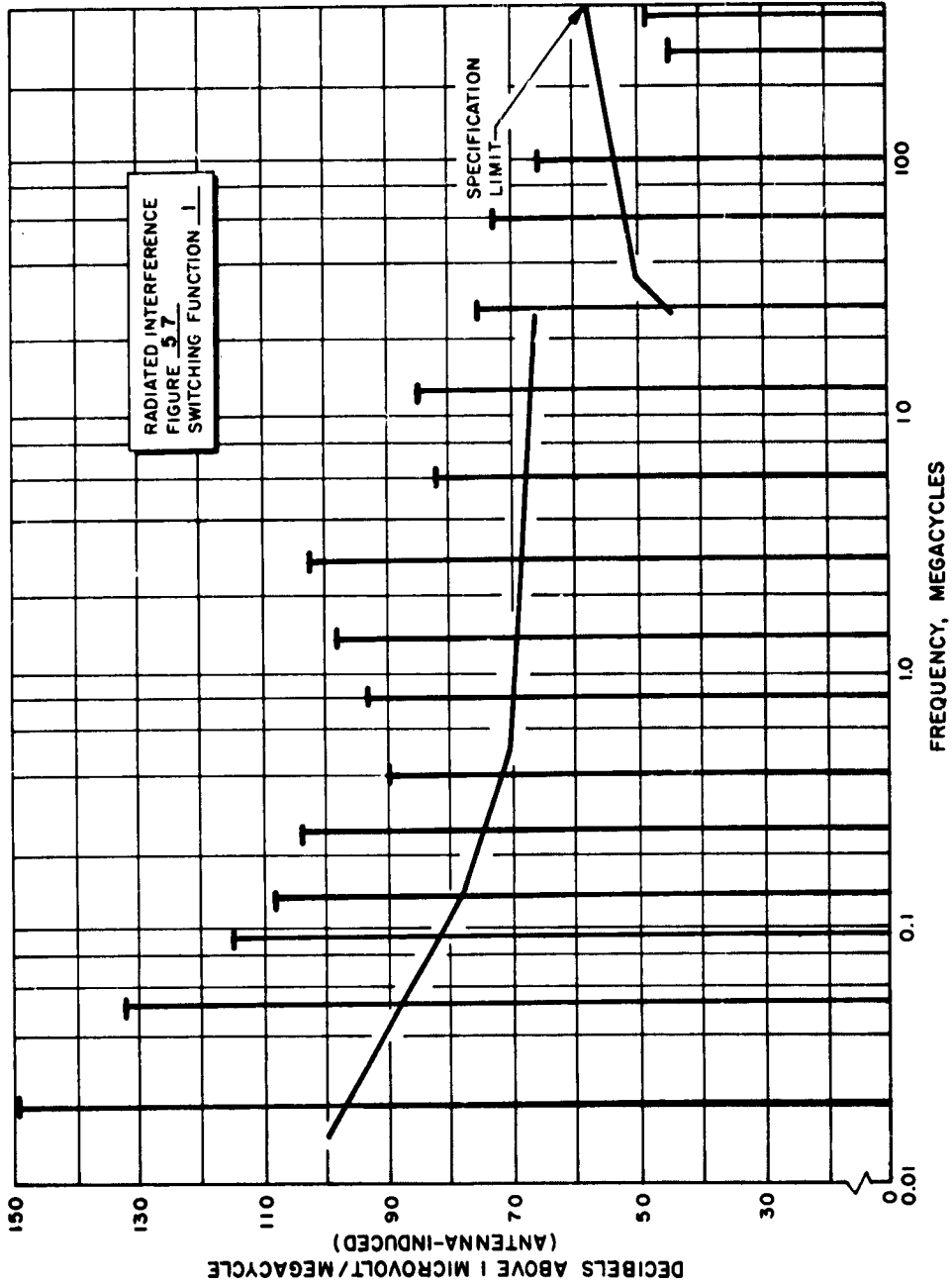

Figure 57. Switching Function 1 of Radiated Interference

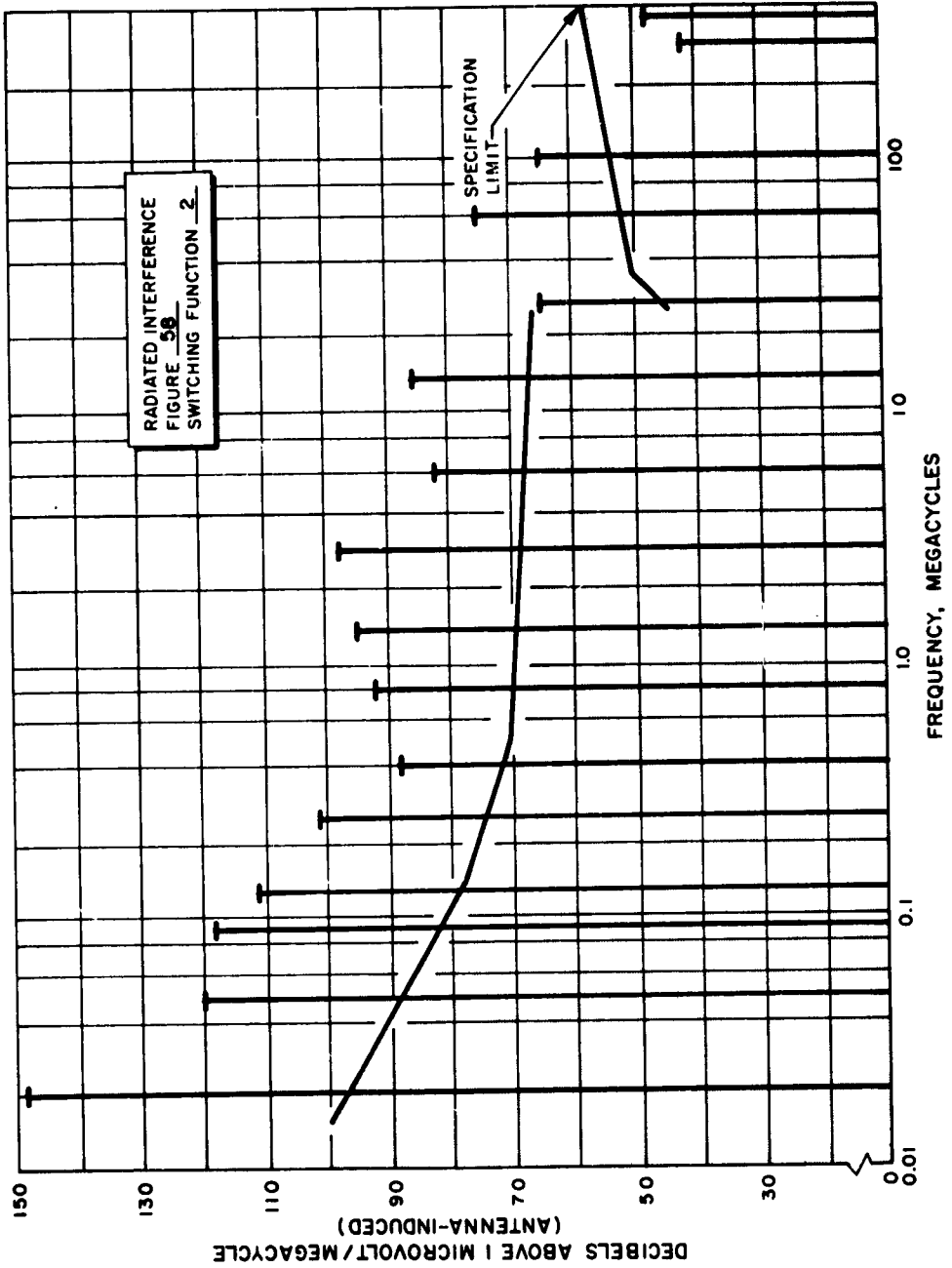

Figure 58. Switching Function 2 of Radiated Interference

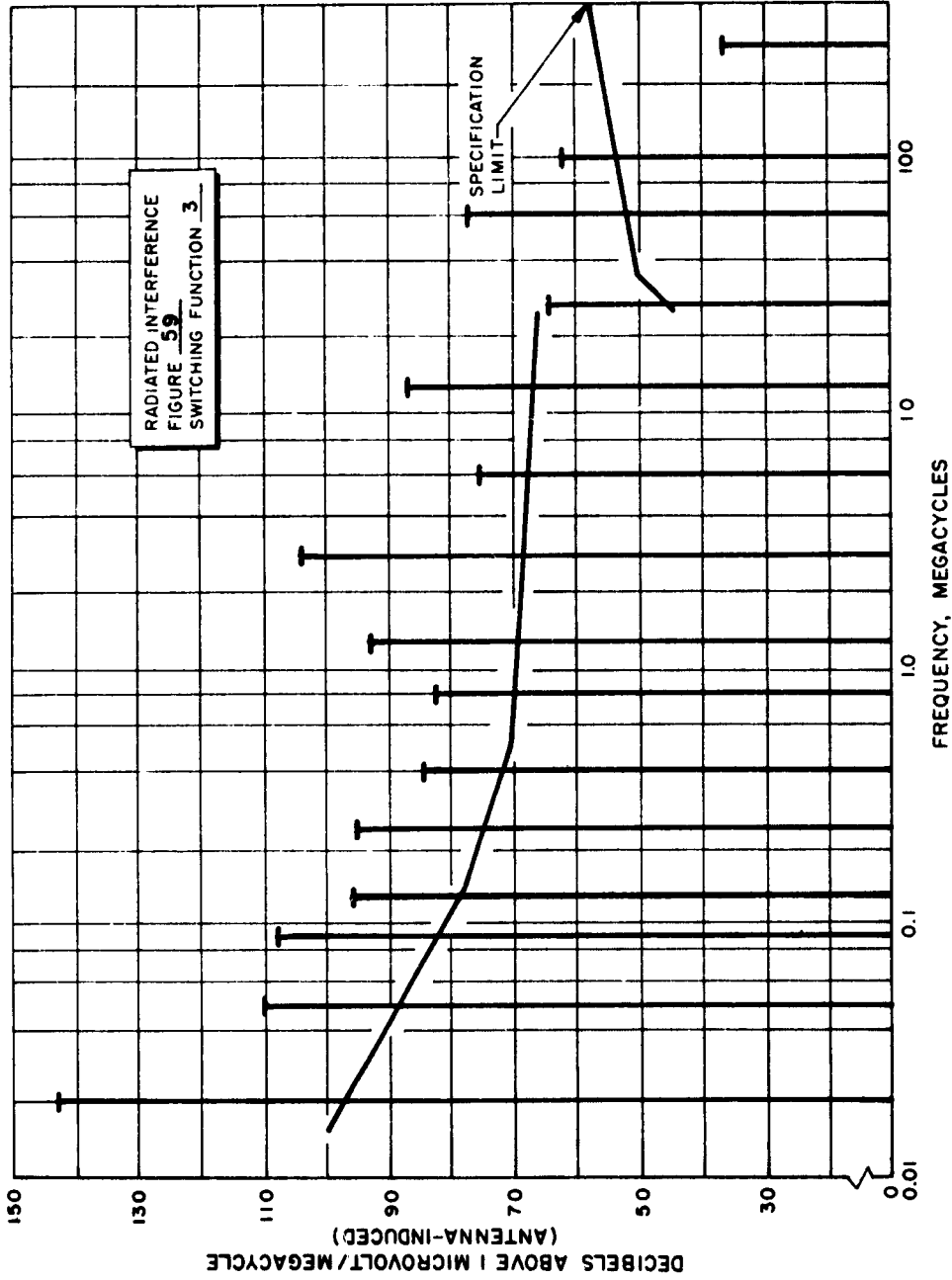

Figure 59. Switching Function 3 of Radiated Interference

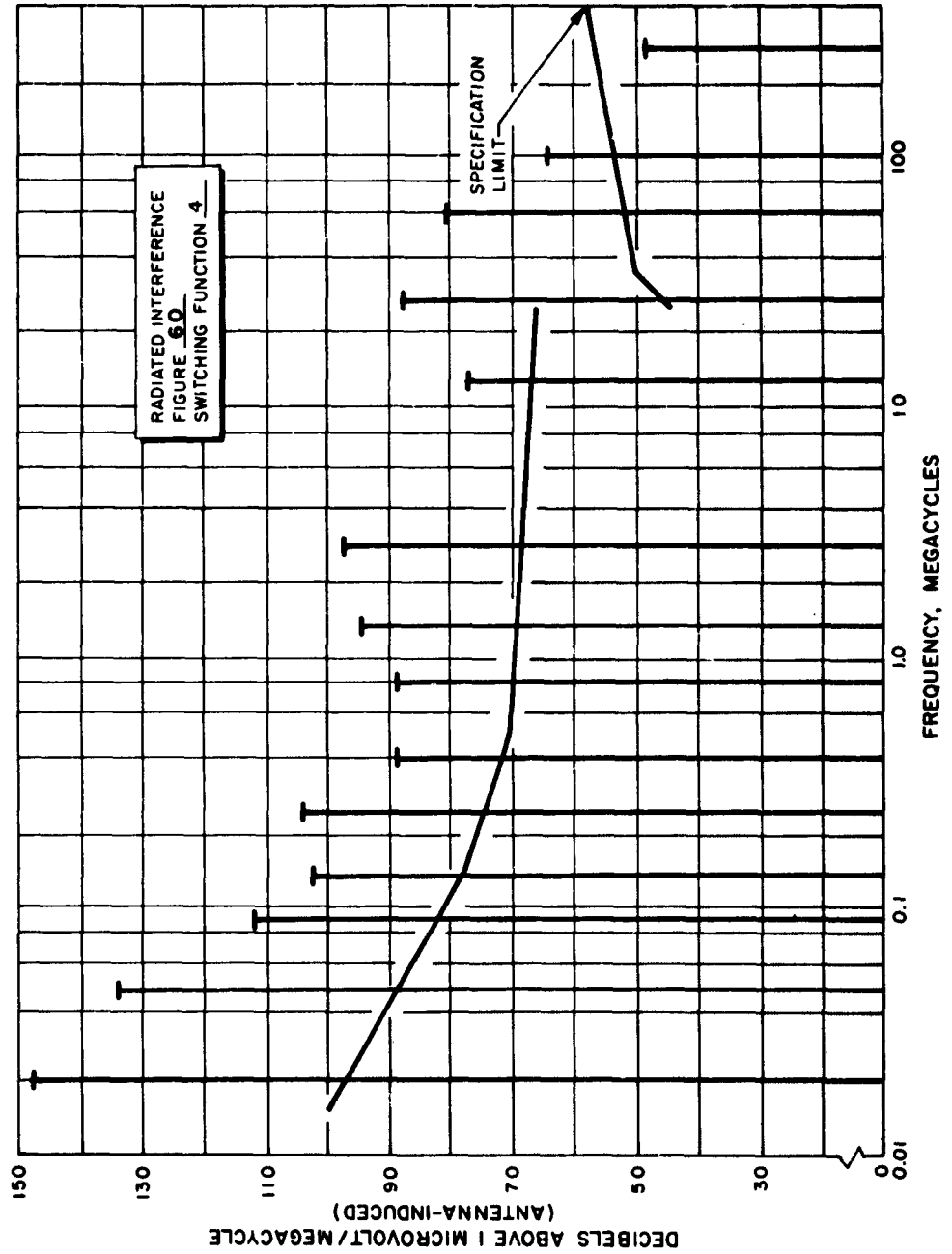

Figure 60. Switching Function 4 of Radiated Interference

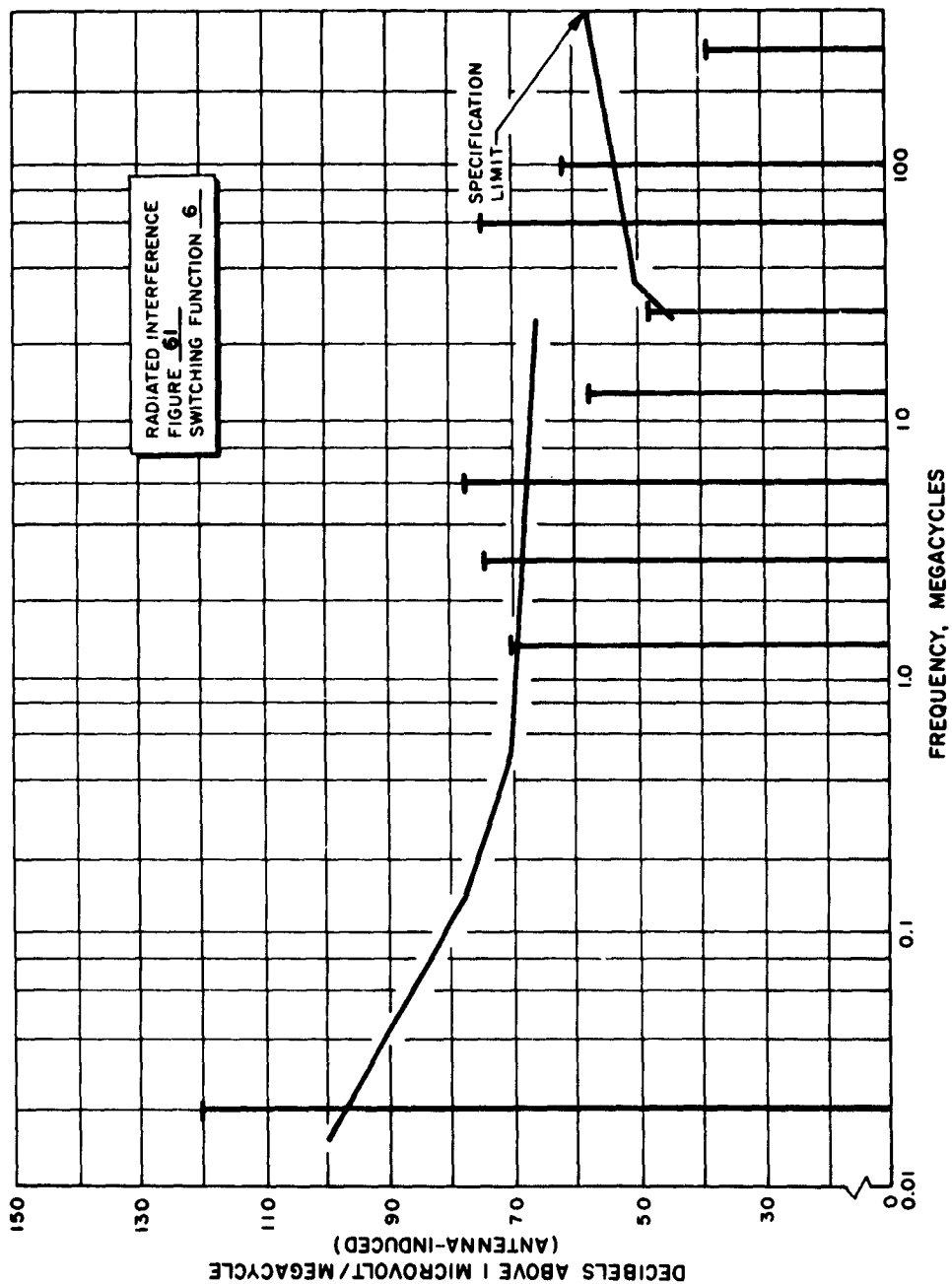

Figure 61. Switching Function 6 of Radiated Interference

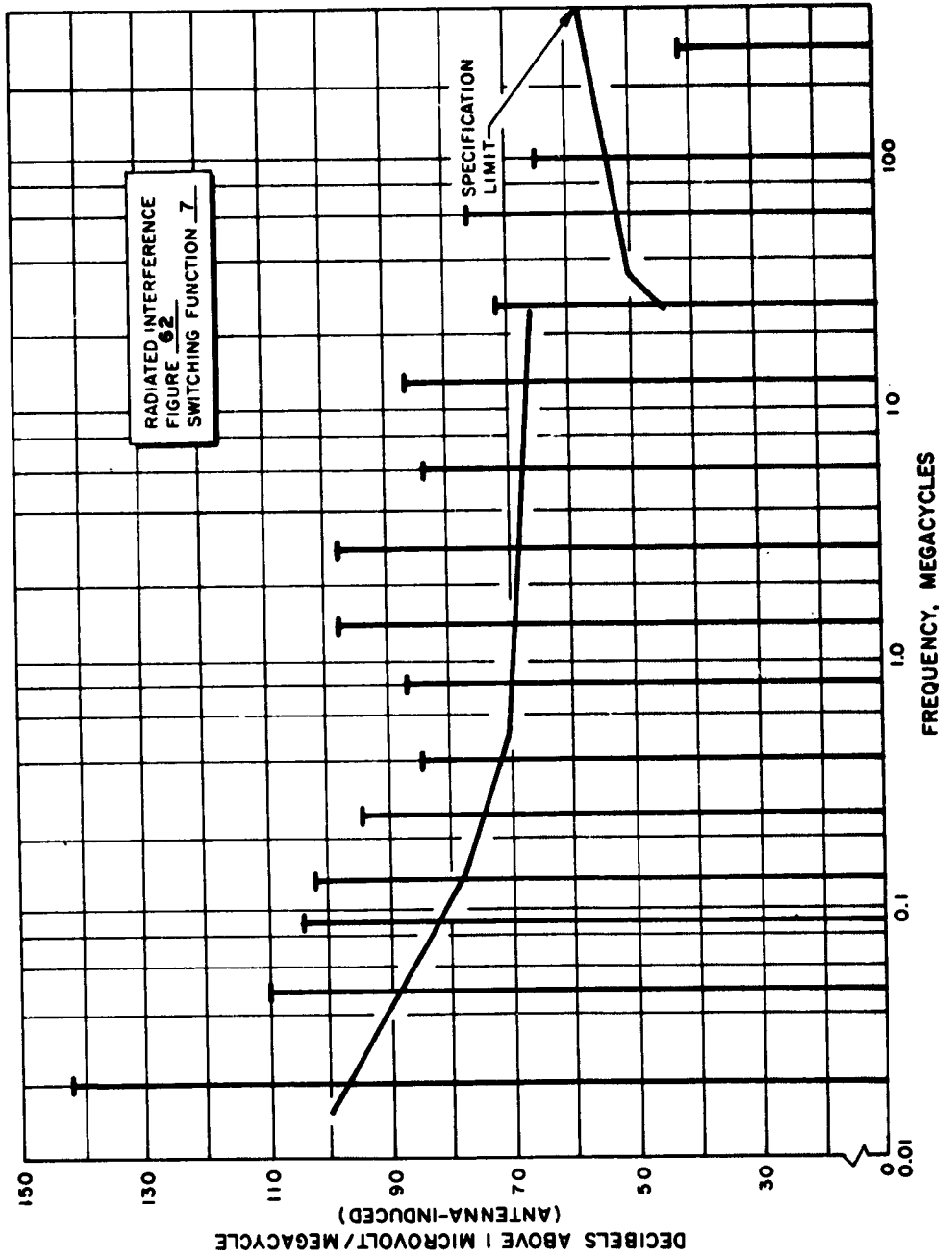

Figure 62. Switching Function 7 of Radiated Interference

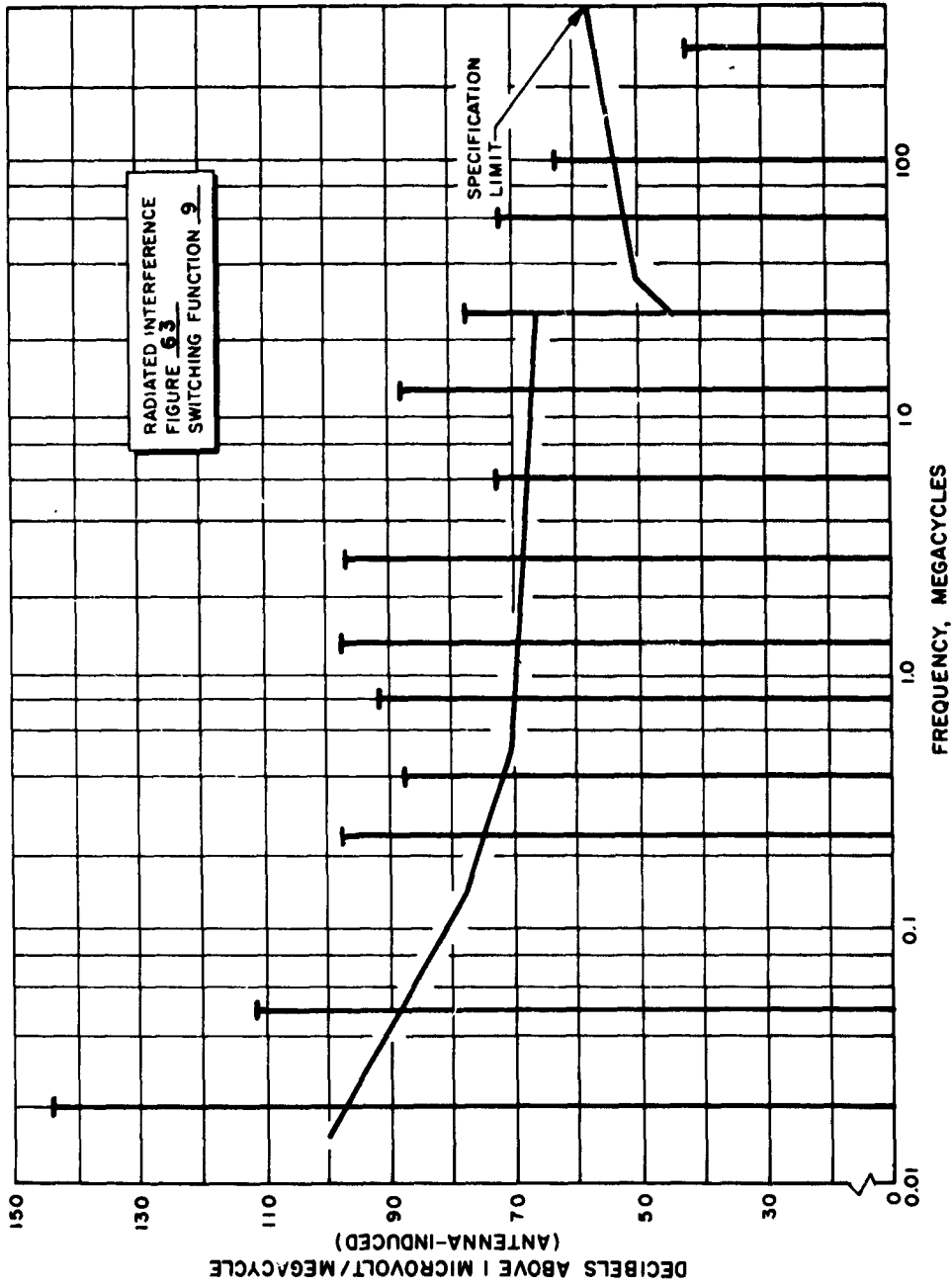

Figure 63. Switching Function 9 of Radiated Interference

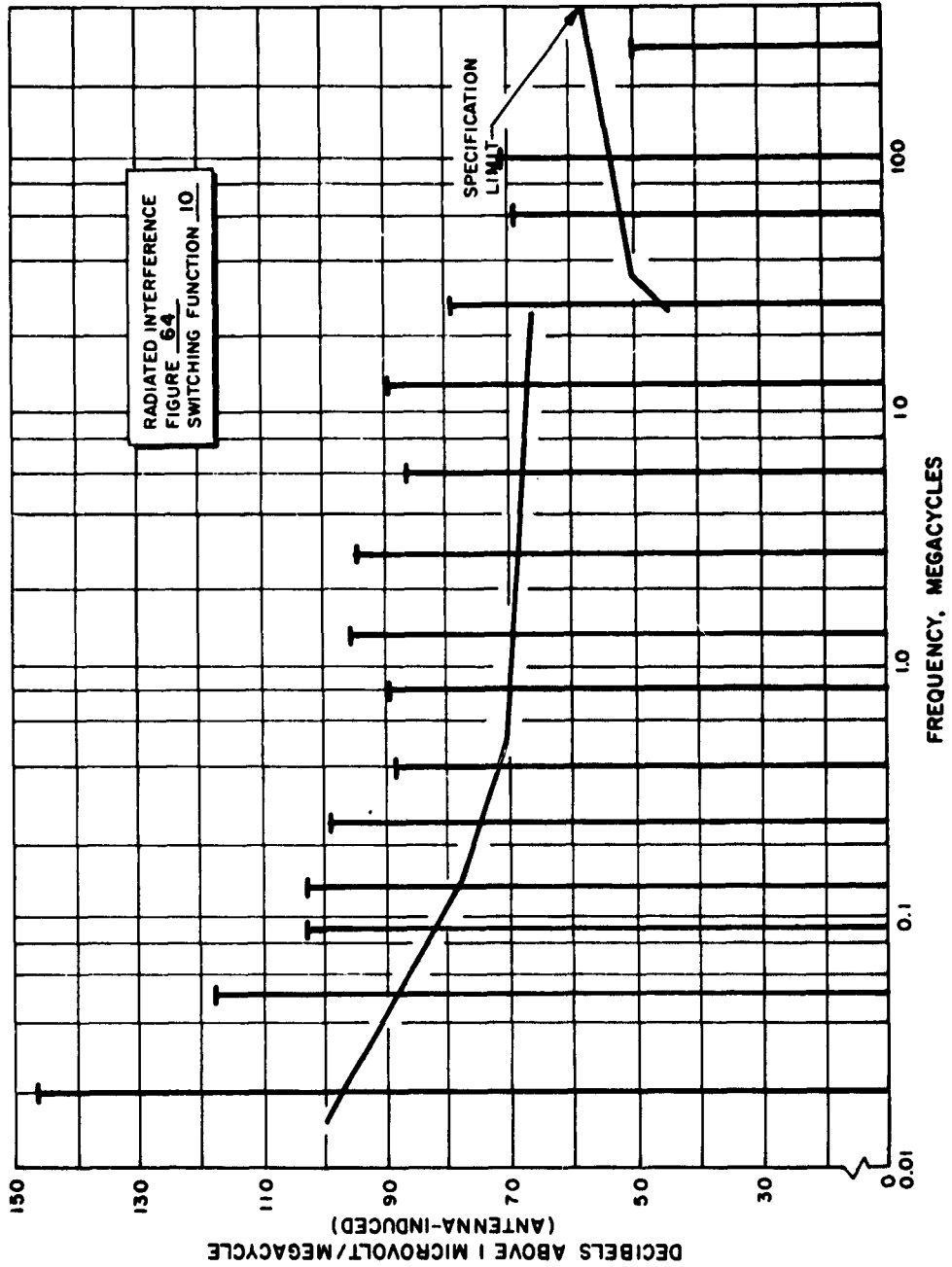

Figure 64. Switching Function 10 of Radiated Interference