

**UNCLASSIFIED**

**AD** **407 062**

**DEFENSE DOCUMENTATION CENTER**

**FOR**

**SCIENTIFIC AND TECHNICAL INFORMATION**

**CAMERON STATION, ALEXANDRIA, VIRGINIA**



**UNCLASSIFIED**

NOTICE: When government or other drawings, specifications or other data are used for any purpose other than in connection with a definitely related government procurement operation, the U. S. Government thereby incurs no responsibility, nor any obligation whatsoever; and the fact that the Government may have formulated, furnished, or in any way supplied the said drawings, specifications, or other data is not to be regarded by implication or otherwise as in any manner licensing the holder or any other person or corporation, or conveying any rights or permission to manufacture, use or sell any patented invention that may in any way be related thereto.

407 062

CATALOGED BY DDC 407062

AS AD No. \_\_\_\_\_

63-4-

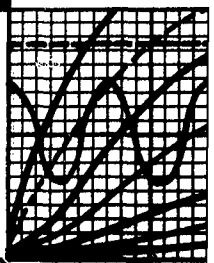
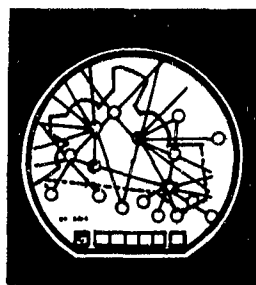

FINAL REPORT  
Project No. 114-10-2X

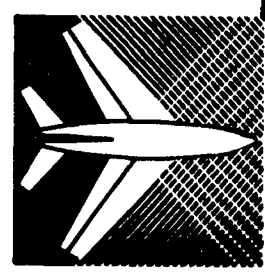

# STANDARD DIRECTIONAL LOCALIZER OVERFLIGHT INTERFERENCE

JULY 1962

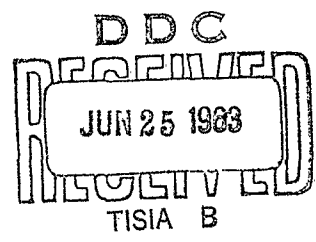

**FEDERAL AVIATION AGENCY**  
**Systems Research & Development Service**  
**EXPERIMENTATION DIVISION**  
Atlantic City, New Jersey

FINAL REPORT  
STANDARD DIRECTIONAL LOCALIZER  
OVERFLIGHT INTERFERENCE

PROJECT NO. 114-10-2X

Prepared by:

F. W. Marschall

July 1962

This report has been approved for general distribution.

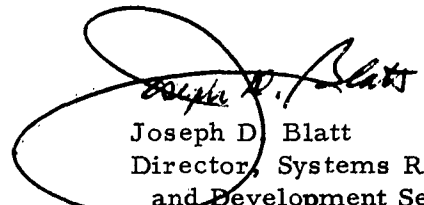
  
Joseph D. Blatt  
Director, Systems Research  
and Development Service  
Federal Aviation Agency

Experimentation Division  
National Aviation Facilities Experimental Center  
Atlantic City, New Jersey

This report has been released to the U. S. Department of Commerce,  
Business and Defense Services Administration, Office of Technical  
Services, Washington 25, D. C., for reproduction and sale to the  
general public.

TABLE OF CONTENTS

	Page
LIST OF ILLUSTRATIONS . . . . .	i
ABSTRACT . . . . .	iii
INTRODUCTION . . . . .	1
DISCUSSION . . . . .	1
Static Tests . . . . .	2
Dynamic Tests . . . . .	3
Mathematical Analysis . . . . .	4
RESULTS . . . . .	6
ACKNOWLEDGMENT . . . . .	8

## LIST OF ILLUSTRATIONS

Figure 1	Typical Interference Volume
Figure 2	Standard Directional Localizer
Figure 3	Sideband Antenna Patterns
Figure 4	Test 1 Geometry
Figure 5	Test 1 Recording Setup
Figure 6	Test 1 CDI and FS Deviations Versus Azimuth
Figure 7	Test 2 Geometry
Figure 8	Test 2 Recording Setup
Figure 9	Test 2. CDI and FS Deviations Versus Antenna Heights
Figure 10	Test 2. CDI and FS Deviations Versus Altitude
Figure 11	Test 3, Geometry
Figure 12	Test 3 Recording Setup
Figure 13	Test 3, CDI Deviations Versus Azimuth
Figure 14	Test 4 Geometry
Figure 15	Test 4 Recording Setup
Figure 16	Test 4. Per Cent Reflection Versus Distance from Localizer
Figure 17	Test 5 Geometry
Figure 18	Test 5 Recording Setup
Figure 19	Test 5 Interference Patterns
Figure 20	Test 6 Geometry
Figure 21	Test 6 Interference Patterns
Figure 22	Test 7 Geometry

LIST OF ILLUSTRATIONS (Continued)

Figure 23	Test 7 CDI Deviations Versus Altitude of Aircraft Over Localizer Antenna
Figure 24	Case SL Geometry
Figure 25	Case SL - P, D, and F Versus Distance from Localizer
Figure 26	DL Geometry
Figure 27	ST Geometry
Figure 28	DT Geometry
Figure 29	SL Profile
Figure 30	DL (1) Profile
Figure 31	DL (2) Profile
Figure 32	DL (3) Profile
Figure 33	ST (1) Profile
Figure 34	ST (2) Profile
Figure 35	ST (3) Profile
Figure 36	DT (1) Profile
Figure 37	DT (2) Profile
Figure 38	DT (3) Profile

Experimentation Division, Systems Research and Development Service,  
Federal Aviation Agency, Atlantic City, N. J.  
STANDARD DIRECTIONAL LOCALIZER OVERFLIGHT INTERFERENCE  
By F. W. Marschall, July 1962, 8 pp., including 38 illus., Final Report.  
(Project No. 114-10-2X)

#### ABSTRACT

This report describes the reflection interference effects of overflying aircraft on ILS localizer receivers in the landing area. The data were derived from field tests and mathematical analysis, and include both static and dynamic receivers. Field test data were gathered using a standard directional waveguide localizer.

Interference is defined as Course Deviation Indicator (CDI) deviations of ten microamperes or more at a frequency of one cycle per second or less and having a duration of one-half second or more.<sup>1</sup> Figure 1 represents a typical volume in which one aircraft would cause interference to a second aircraft that is in a landing configuration near touchdown. This volume was derived from the results of field tests and mathematical analysis. Here the interfered aircraft is landing at 210 feet per second (fps), 10,000 feet from the localizer, and the interfering aircraft is a DC-3 traveling in the same direction at 340 fps. Interference volumes will have different geometries and positions depending upon the geometry of the aircraft, the velocities of the aircraft, the cross section of the interfering aircraft, the beam structures of the antennas, and the criteria used for interference.

Interference volumes are limited in azimuth to plus and minus  $8^{\circ}$  because of the narrow azimuth beam structure of the waveguide localizer antenna. Interference volumes are limited in altitude by the RF cross sectional area of the interfering aircraft and the vertical lobe structure of the localizer antenna. Volumes of interference parallel to the runway that are generated by aircraft flying parallel to the runway are primarily limited by the frequency of the interference.

In the field tests, interference volumes to static receivers were more predictable and in most instances of greater duration than interference to dynamic receivers.

1. The frequency criterion was derived from the FAA report "Capability of the Directional Localizer as a Source of Azimuthal Guidance for Landings" by Hollm, Proferes, and Winnick. The duration criterion was an extension of the frequency criterion. The amplitude criterion was arbitrary.

## INTRODUCTION

The standard directional waveguide localizer was developed originally to remedy the problem caused by unfavorable siting conditions, particularly large reflecting objects such as hangars, in the radiation pattern of the standard localizer. These reflective objects caused "bends" in the course and in some instances were of such magnitude that the course was uncommissionable. The philosophy of the remedy behind the directional localizer was to confine most of the radiated energy to a narrow sector (approximately plus and minus  $8^\circ$ ) about the runway centerline, since most reflective objects would not be in this sector. This successful approach led to consideration of the evolutionary step of using the directional localizer as a landing aid as contrasted to its original function as an approach aid. Consideration of using the directional localizer as a landing aid generated certain reservations concerning its suitability in this capacity. One of these reservations concerns the reflection effects of overflying aircraft on course deviation indications and field strength of localizer receivers in aircraft that are in a landing configuration.

To gather data on the extent of this reflection interference, field tests were conducted and a mathematical analysis made of possible interference volumes. These tests were conducted from February 1961 to July 1961 at the National Aviation Facilities Experimental Center (NAFEC), Atlantic City, New Jersey.

Field tests were conducted using stationary aircraft receivers located in the touchdown area and airborne receivers in an aircraft in an approach configuration while other aircraft flew in possible interference volumes. The field tests yielded information on amplitude, frequency, and duration of interference within the accuracy limitations of the test program.

To define precisely interference volumes, verify test data and gather data on geometries and velocities beyond the scope of the field test program, a mathematical analysis was made on a frequency and duration basis. In this analysis certain volumes can be excluded on a frequency or duration basis and other volumes that are included on this basis can be excluded on an amplitude basis.

## DISCUSSION

All field tests were conducted using the commissioned standard directional waveguide localizer antenna at the stop end of Runway 13 at NAFEC, Atlantic City, New Jersey (Fig. 2). This localizer uses a waveguide antenna 117 feet long with 18 slots. Figure 3 shows the approximate sideband pattern in the horizontal plane of the waveguide array and the clearance array.

Field tests were conducted under both static and dynamic conditions, that is, with aircraft receivers located in a stationary truck in one test; and

aboard aircraft making approaches in another test. The first tests were conducted under static conditions. The principal purpose of the static tests was to determine the limits and amplitude of interference on a range, altitude, and azimuth basis.

(A) Static tests: In the static tests the interference to landing aircraft was simulated using three antennas located in the touchdown area. This area was 1,000 feet from threshold and 9,900 feet from the localizer. The antennas were placed at different heights to observe the effect of antenna height on interference. Each antenna was connected to a localizer receiver and a field strength indicator (a converted localizer receiver). The output of the receivers and indicators were recorded on a six-channel recorder. All equipment was truck mounted.

Test 1 was conducted to observe interference in azimuth as the distance between the interfering aircraft and the localizer antenna increased. This test consisted of flying the tracks and altitudes indicated in the program (Fig. 4). The recording setup for this test is shown in Figure 5. The interfering aircraft was a DC-3 flying at an airspeed of 150 knots. Figure 6 shows the envelope of CDI deviations, in microamperes, and field strength deviations, in per cent of quiescent value,<sup>2</sup> versus the azimuth of the aircraft as viewed from the directional localizer antenna for tracks 8 through 13. This data was derived from the ten foot antenna and the interference distribution in azimuth is typical of the data gathered at the 20-foot and 28-foot antennas.

Test 2 was conducted to observe the effect of receiver antenna height on interference at various altitudes and to observe interference as a function of altitude and range. Figure 7 illustrates the geometry of the recording setup and Figure 8 the recording setup for this test. This test consisted of flying the tracks and altitudes indicated in the program (Fig. 7). The interfering aircraft was a DC-3 flying at an airspeed of 150 knots. Figure 9 shows the maximum CDI deviations and maximum field strength deviations versus antenna height for altitudes of 3,500, 4,500, and 9,500 feet. Figure 10 shows maximum CDI deviations and maximum field strength deviations versus altitude. This data was derived from the ten foot antenna and the relative amplitudes are typical of the data gathered on the 20-foot and 30-foot antennas. The range of interference was essentially limited to a volume between two vertical planes, both perpendicular to the runway centerline, one passing through the transmitter antenna and the other passing through the receiver antenna.

Test 3 was conducted to observe the effect of elevation on the azimuthal distribution of interference. The interfering aircraft was an HI3H helicopter

2. Quiescent value is the value of the variable that exists when no interfering signal is present.

flying the program at an airspeed of 40 knots (Fig. 11). Figure 11 also illustrates the geometry of test setup and Figure 12 the test setup. The envelope of maximum CDI deviations versus the azimuth of the helicopter for the given altitudes is shown in Figure 13. This datum was taken from the 30-foot antenna.

Test 4 was conducted to observe the percentage of the reflected signal caused when the waveguide only was excited by carrier energy; the clearance array was not energized. Figure 14 illustrates the geometry of the recording setup and Figure 15 the recording setup. An SA-16 flew the program (Fig. 14) at an airspeed of 100 knots. Figure 16 shows the envelope of reflected energy in per cent of the direct signal for altitudes of 2,000, 4,000, and 8,000 feet. The areas indicated "frequency limited area" are those areas in which the AGC action of the receiver attenuated the recordings such that calibration information was invalid.

(B) Dynamic tests: In the dynamic tests two aircraft were used, a DC-3 as the interfering aircraft and a Twin Beech as the interfered aircraft.

Test 5 was conducted to observe the extent of interference to a landing aircraft caused by another aircraft taking off and flying over the waveguide antenna. Figure 17 illustrates the geometry of the test setup and Figure 18 the recording setup in the Twin Beech. In each run a DC-3 started to take off at the time the Twin Beech was making a normal approach, approximately three miles behind it. The DC-3 then took off and made a controlled rate of climb to 100 feet, and 200 feet at the time it passed over the localizer as indicated in the program (Fig. 17). Each X in the program indicates that one run was made for the condition given. Figure 19 presents interference recordings taken in the Twin Beech for this test.

Test 6 was conducted to observe the extent of interference to a landing aircraft caused by aircraft making longitudinal and transverse passes over the runway. Figure 20 illustrates the geometry of the test setup and Figure 18 the recording setup in the Twin Beech. In each run the Twin Beech made a normal visual approach while the DC-3 flew tracks 1 and 12 as indicated in the program (Fig. 20). Figure 21 presents interference recordings for four of these runs.

Test 7 was conducted to observe the effect of the height of a landing aircraft on interference. Figure 22 illustrates the geometry of the test setup and Figure 18 the recording setup in the Twin Beech. At the beginning of the run, both aircraft were two miles from threshold; the DC-3 proceeded at 150 knots at constant altitude (indicated ALT in the program) and at one half localizer CDI scale. The Twin Beech proceeded at 95 knots on a normal approach and leveled off at an altitude indicated "h" in the program. Fig. 23

presents the maximum CDI deviations versus the height of the Twin Beech for DC-3 altitudes of 1,000 feet and 2,000 feet.

(C) Mathematical analysis: The field tests produced significant data on interference volumes on an amplitude, frequency, and duration basis. However, many situations that could cause interference are difficult, or practically impossible, to obtain in field tests since the variables necessary to simulate the condition cannot be controlled accurately. The following mathematical analysis was made to investigate more accurately interference volumes with controlled variables and compare the results with field test data.

In this analysis only frequency and duration are considered. Amplitude has been eliminated since it is a function of a number of variables; for example, aircraft size, attitude, and geometry; forward and back scattering; antenna shielding; transmitter and receiver lobe structure; and becomes a unique case for each combination.

In this analysis a number of different cases are considered. Each case is identified by two letters. The first letter refers to the receiver velocity, either S for static or D for dynamic. The second letter refers to the interfering aircraft track; it is letter L for longitudinal or T for transverse. In all cases, the receiver position is constant and the interference is dynamic and moving. The receivers were maintained at a constant position under dynamic conditions so that the interfered aircraft would always be in the touchdown area at the time of interference. Table I lists the cases considered.

TABLE I

Case	Receiver	Rec. Pos.	Interfering Aircraft Track
SL	Static	Constant	Longitudinal
DL	Dynamic	Constant	Longitudinal
ST	Static	Constant	Transverse
DT	Dynamic	Constant	Transverse

Figure 24 illustrates the geometry for the SL case. The localizer antenna is located at point o, the receiver is located at point l, and the interfering aircraft is located at point i. Line ol is co-linear with the runway centerline and points o, l, and i are in a vertical plane. The distance of the incident and reflected path of the interfering signal is represented by A and B respectively. The distance of the direct signal path is represented by R. X represents the horizontal distance from the localizer to the interfering aircraft,  $V_i$  is the interfering aircraft velocity and Z is the interfering aircraft height. The path length difference (P) is  $P = A + B - R$ . Applying the sum of the squares to the geometry yields equation 24-2 and the rate of change of path length

difference is given by equation 24-6. This will give an interference frequency of  $\frac{dP}{dt\lambda}$ , where  $\lambda$  is equal to the wavelength of the transmitted frequency.

The longitudinal analyses are valid for any aircraft flying parallel to the runway centerline and at a distance  $Z$  from it.

Figure 25 illustrates the relationship between  $P$ ,  $D$ , and  $f$  vs.  $X$  for

$$\begin{aligned}V_i &= 200 \text{ feet/second} \\Z &= 2,000 \text{ feet} \\ \lambda &= 8.9 \text{ feet, } 110 \text{ Mc.} \\ R &= 10,000 \text{ feet,}\end{aligned}$$

where  $D = dP/dt$ .

For clarity in this example,  $f$  has arbitrarily been chosen as equal to  $-D/\lambda$ .

Figure 26 illustrates the geometry for DL. The symbolism is the same as SL except that  $V_1$  is the velocity of the landing aircraft and  $S$  is the initial distance from the localizer.

Using the same approach as in SL, the rate of change of path length difference is given by equation 26-7.

In this example,  $f$  was evaluated at increments of  $t$ ;  $t = t_0, t_1, \dots$ .  $t_n$  and  $S$  was correspondingly incremented so that  $(t_i - t_0) V_1 = S - R$  so the derivative was always evaluated when the landing aircraft was at a distance  $R$  from the localizer.

Figure 27 illustrates the geometry for ST. The symbolism is the same as SL except for  $Y$ , which is the horizontal distance from the centerline to the aircraft. In this example the rate of change of path length difference is given by equation 27-6.

Figure 28 illustrates the geometry for DT. The symbolism is the same as ST except that  $V_1$  is the velocity of the landing aircraft and  $S$  is its initial distance from the localizer. In this example the rate of change of path length difference is given by equation 28-7. As in DL,  $f$  was evaluated at increments of  $t$ , and  $S$  was correspondingly incremented so the derivative was always evaluated when the landing aircraft was at a distance  $R$  from the localizer.

Figures 29 through 38 indicate areas of interference for the examples and conditions given. The region between the lines indicate the area of interference that has a frequency of one cps or less. Where these lines are dashed, this area is less than one-half second in duration or greater than  $8^\circ$  in azimuth.

In the SL example (Fig. 29) it can be noted that the interference area is symmetrical about a vertical line half way between the localizer antenna and the receiving antenna; the zero frequency beat also occurs on this vertical line. The interference area is the same for interfering aircraft flying to or away from the localizer antenna. Since the longitudinal analyses are valid for any aircraft parallel to the runway centerline, a volume of interference may be generated by rotating the area of interference about the runway centerline.

In all the dynamic examples the direction of the interfering aircraft is indicated by an arrow under  $V_i$ . In the DL examples (Figs. 30, 31, and 32) the area of interference leans into the interfering aircraft direction. In the ST examples (Figs. 33, 34, and 35) the interference is symmetrical about a vertical line passing through the runway centerline; the zero beat frequency also occurs on this vertical line. The interference areas do not change significantly as the distance from the localizer changes.

In the DT examples (Figs. 36, 37, and 38), the interference areas also lean toward the direction of the interfering aircraft. If the direction of the interfering aircraft were reversed, these areas would lean in the opposite direction with the same configuration.

## RESULTS

The results are based on the following criteria for interference: Course Deviation Indicator deviations of ten microamperes or more, at a frequency of one cps or less, and having a duration of one-half second or more. Note that these are mutually concurrent conditions; that is, all three must be present simultaneously in order that an interference situation can occur.

1. Considering only frequency duration, an interference volume may exist anywhere within RF line of sight of the airfield since for any geometry, velocity conditions can be set up that will satisfy the criteria. However, whether a particular situation will cause interference is a matter of chance, and the probability of interference appears extremely remote.

2. Amplitude interference is a function of aircraft size, attitude, and geometry, forward scattering from the interfering aircraft as opposed to back scattering, antenna shielding, and transmitter and receiver lobe structure. Here again interference is a matter of chance; however, certain interpolations and extrapolations may be made from data collected on aircraft in the field tests.

3. The overall probability of interference is the combined probability of 1 and 2 above.

4. From the results of the field tests it was found that dynamic test results are not as repeatable as static test results. This is the result of the chance nature of 1 and 2 above.

5. With the given criteria and a DC-3 as the interfering aircraft, the interference in azimuth was limited to plus and minus  $8^{\circ}$ . This is due to the directional properties of the waveguide localizer.

6. Increasing the height of the receiving antenna in the touchdown area significantly reduces the interference.

7. In general, interference under static conditions is greater than interference under dynamic conditions. In instances where the interfering aircraft is on a transverse or opposite track, interference under static conditions is always greater than interference under dynamic conditions.

8. Considerable interference is generated by aircraft flying directly over the localizer antenna at normal take off and landing altitudes.

9. Volumes of interference are definable, confined to limited volumes over the instrument runway, have a limited probability of occurrence and may be readily protected against by means of air traffic control practices.

ACKNOWLEDGMENT

The author wishes to acknowledge the assistance given by the Task Team Members, who are as follows:

W. J. Camp

M. J. Kramer

R. J. Regan

J. J. Ryan

W. Timmons

W. Yost

INTERFERENCE DEFINED AS CDI DEVIATION OF 10 MICROAMPERES OR MORE AT A FREQUENCY OF 1 CYCLE PER SECOND OR LESS AND HAVING A DURATION OF ONE-HALF SECOND OR MORE.

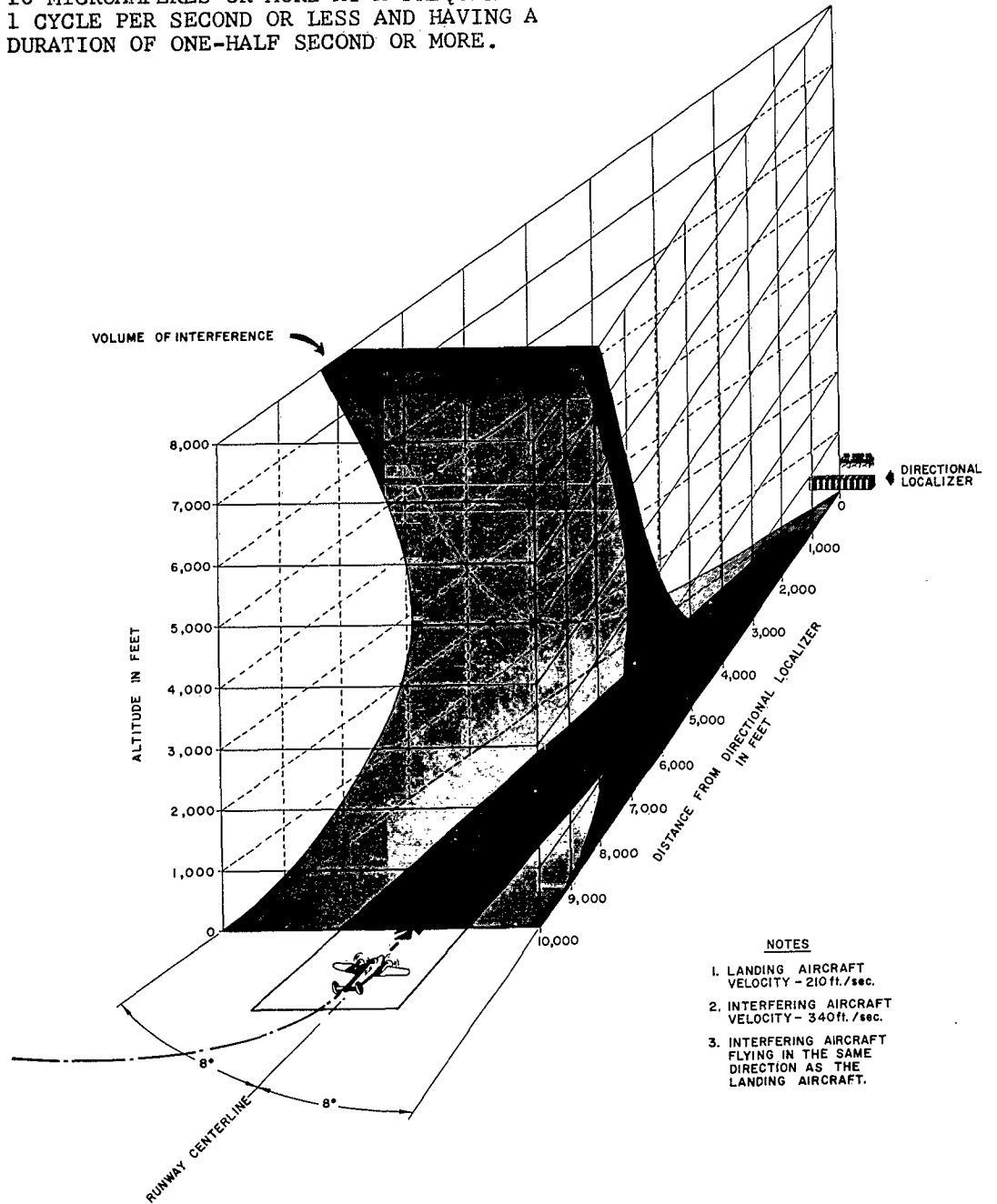

FIG. 1 TYPICAL INTERFERENCE VOLUME

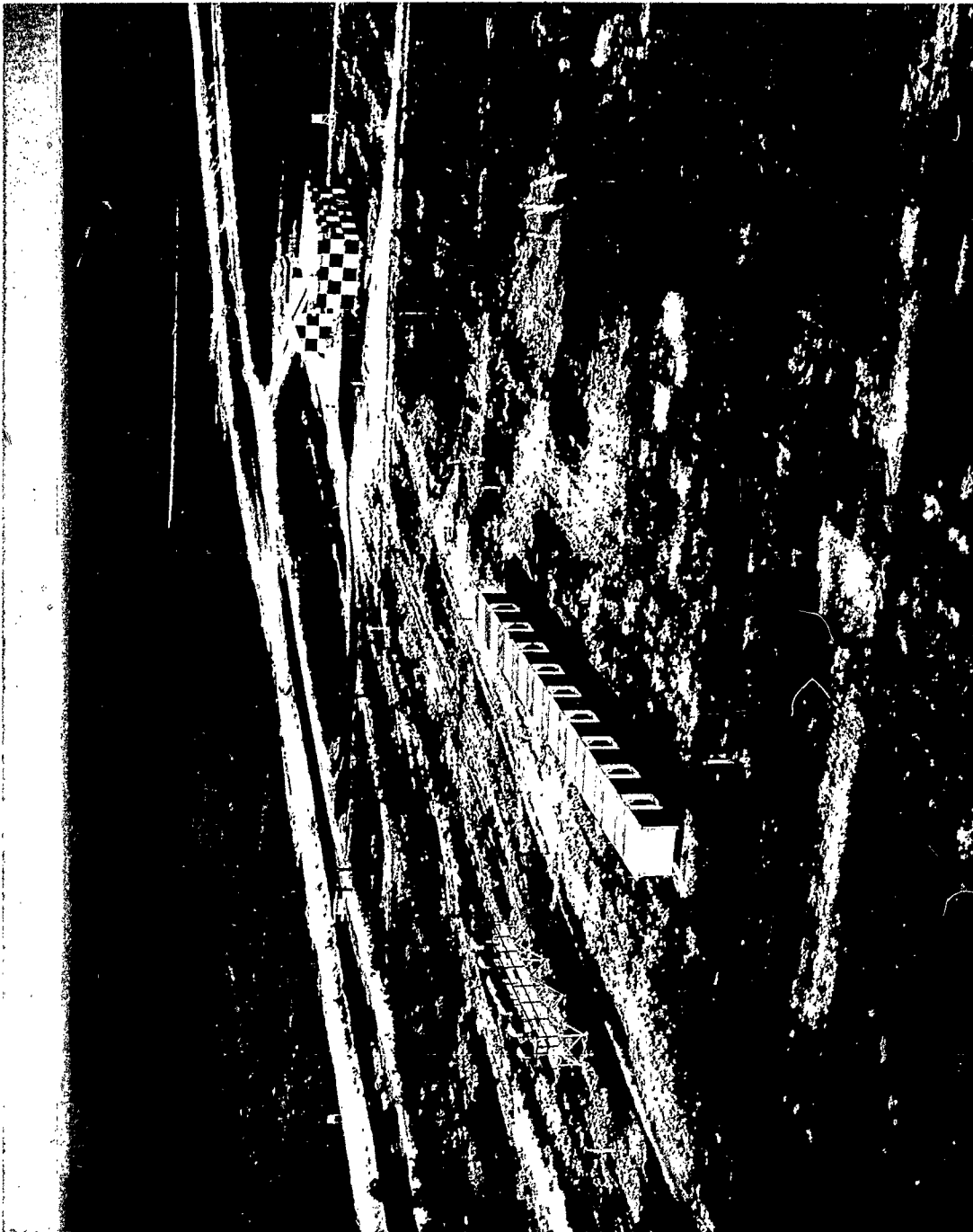

FIG. 2 STANDARD DIRECTIONAL LOCALIZER

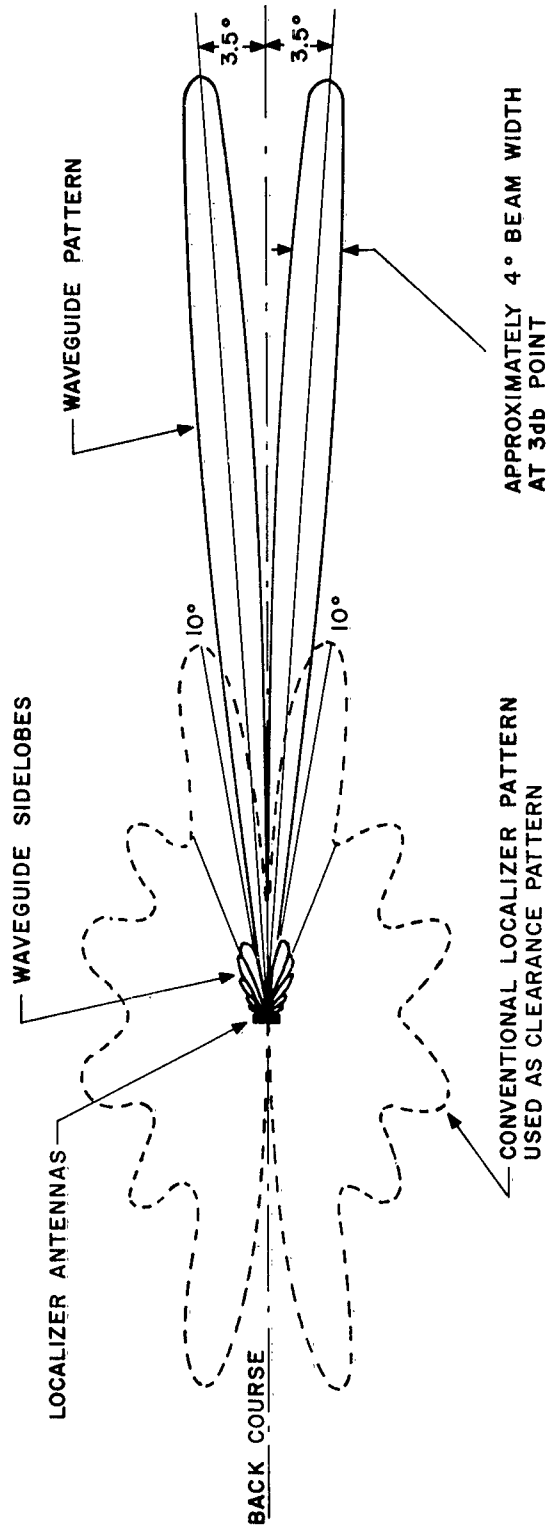
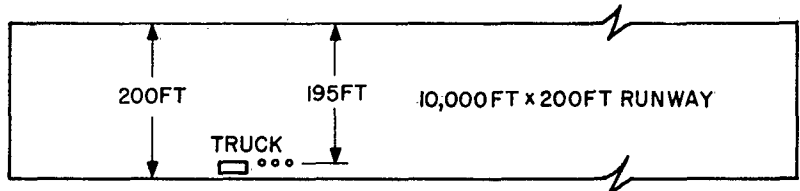
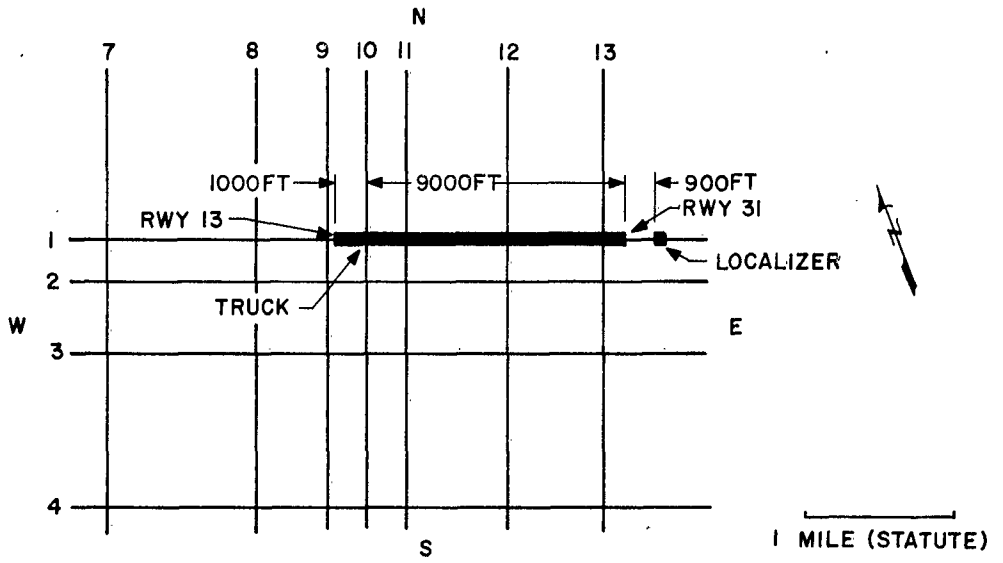

FIG. 3 SIDEBAND ANTENNA PATTERNS



PROGRAM

TRACK NUMBER	ALTITUDE 2000FT
1	
2	
3	
4	
7	
8	X
9	X
10	X
11	X
12	X
13	X

EACH X INDICATES 1 RUN

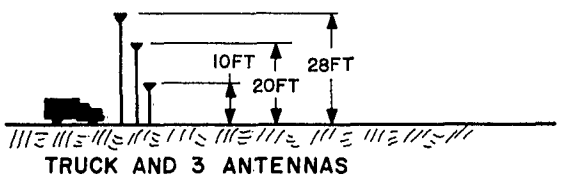

FIG. 4 TEST 1 GEOMETRY

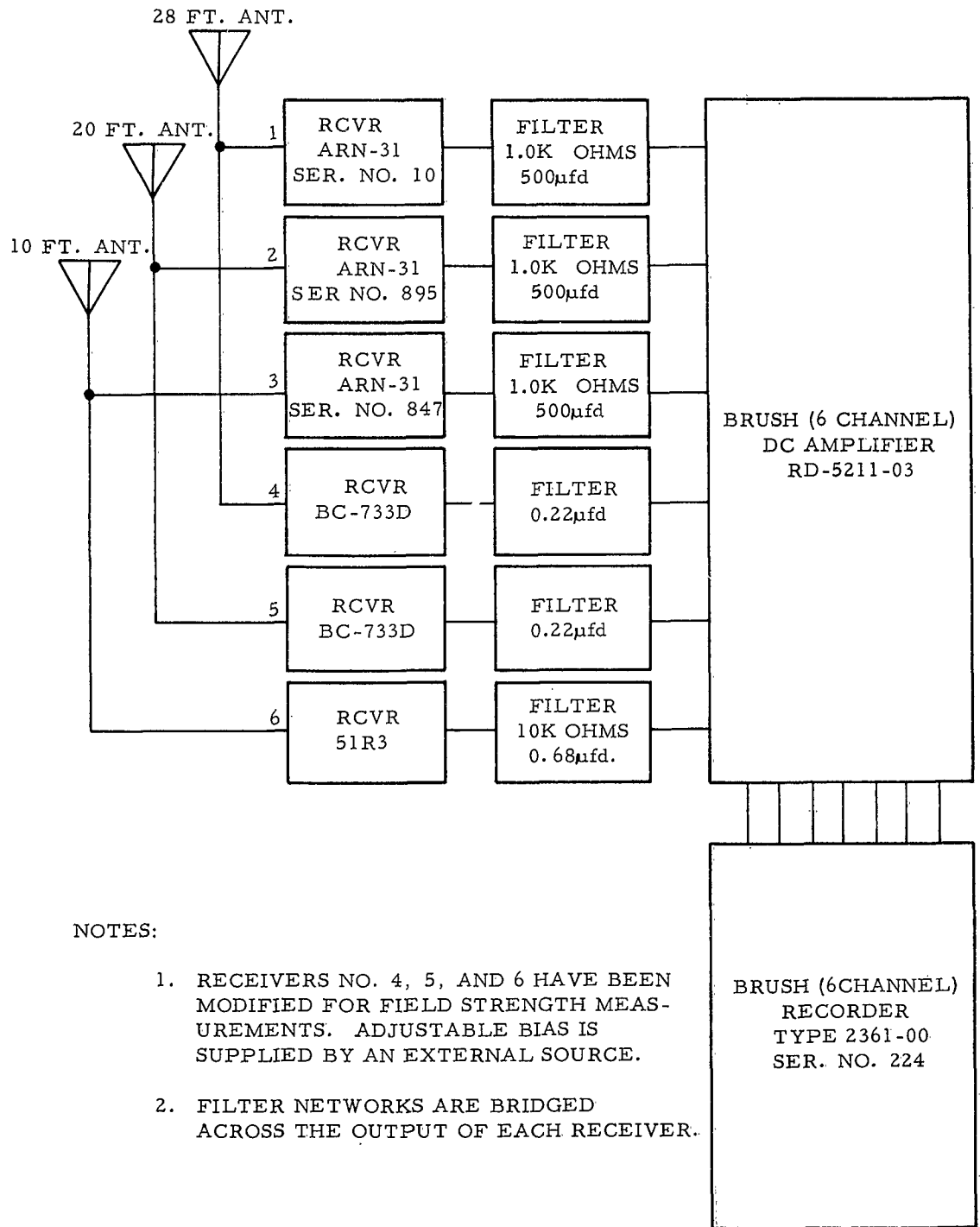

FIG. 5 TEST 1 RECORDING SETUP

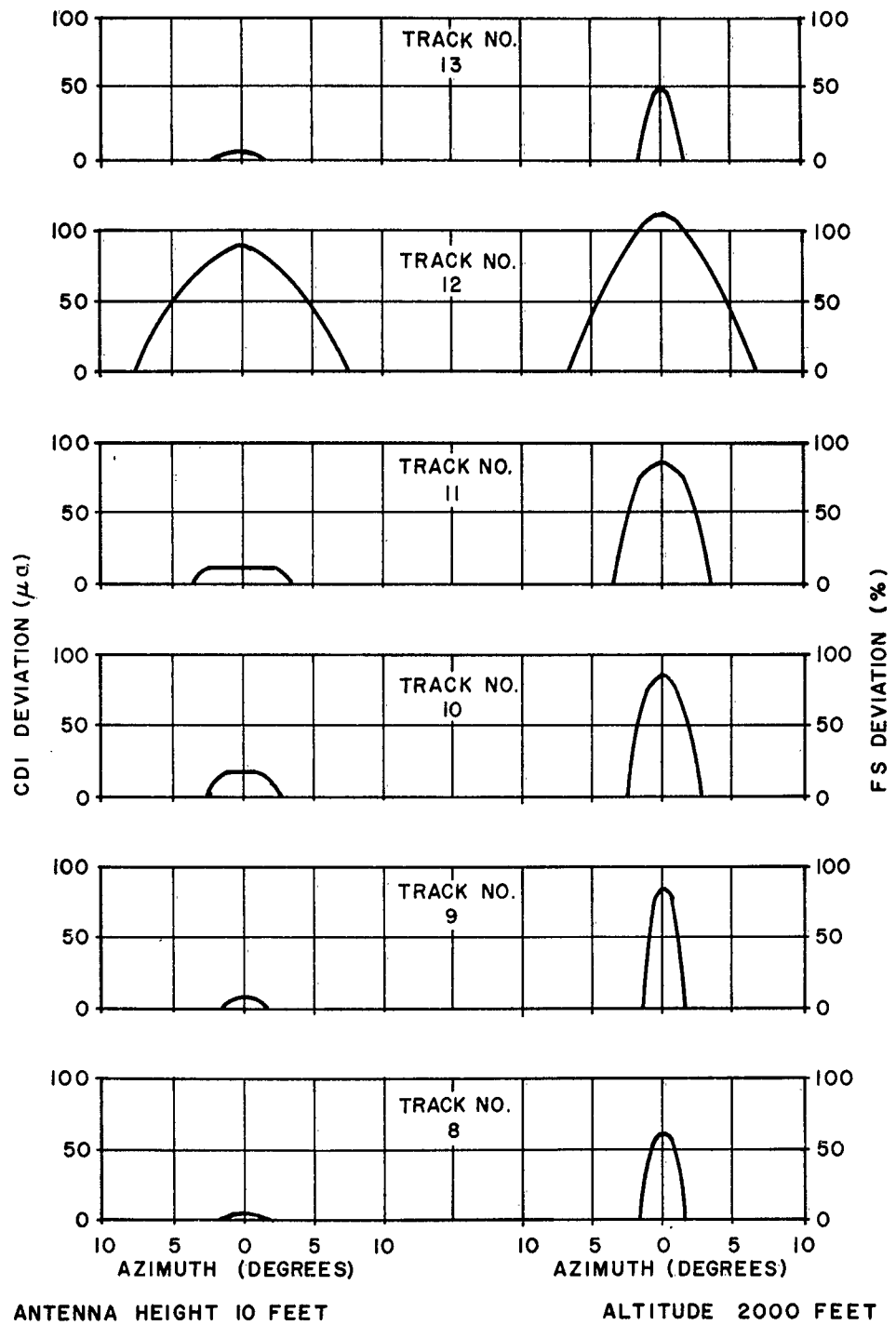
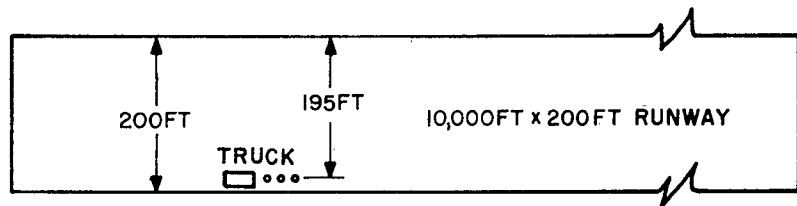
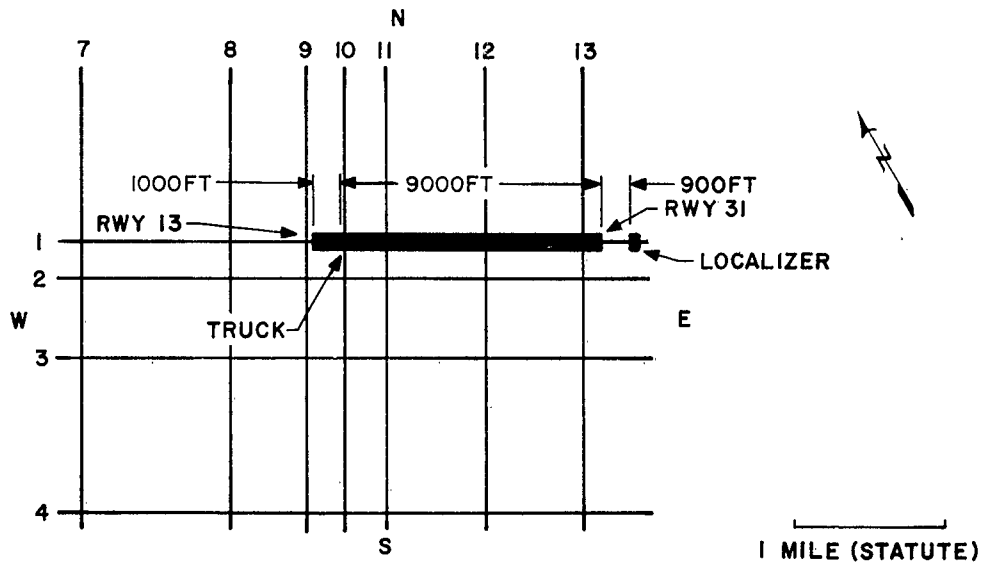

FIG. 6 TEST 1 CDI AND FS DEVIATIONS VERSUS AZIMUTH



PROGRAM	
ALTITUDES	TRACK NO. 1
2,500	
3,500	X
4,500	X
5,500	X
6,500	X
7,500	X
8,500	X
9,500	X
10,500	X
11,500	X
12,500	X
13,500	X
14,500	
15,500	X
16,500	X

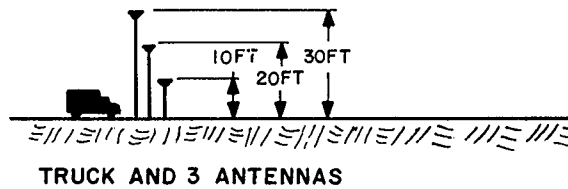
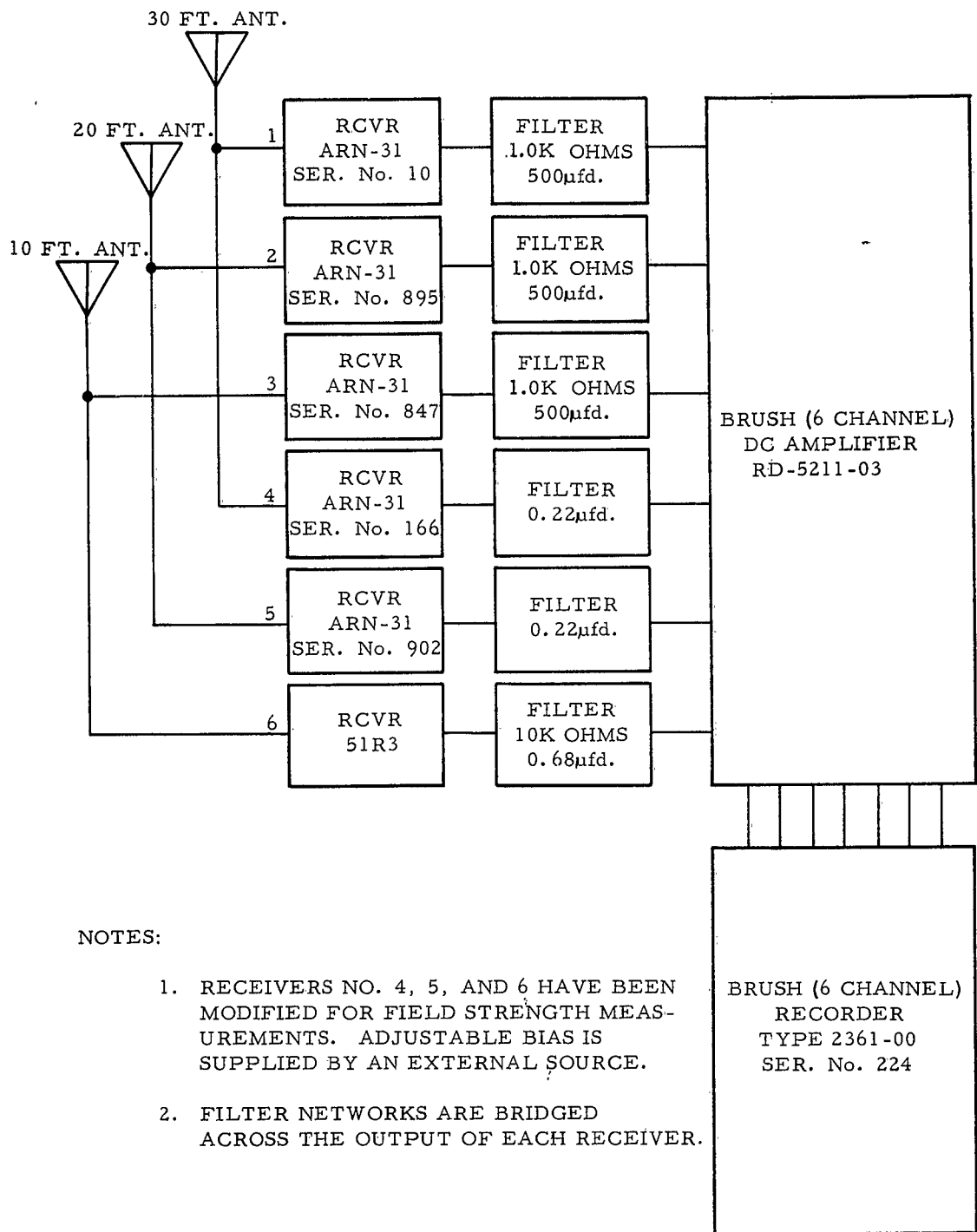

FIG. 7 TEST 2 GEOMETRY



NOTES:

1. RECEIVERS NO. 4, 5, AND 6 HAVE BEEN MODIFIED FOR FIELD STRENGTH MEASUREMENTS. ADJUSTABLE BIAS IS SUPPLIED BY AN EXTERNAL SOURCE.
2. FILTER NETWORKS ARE BRIDGED ACROSS THE OUTPUT OF EACH RECEIVER.

FIG. 8 TEST 2 RECORDING SETUP

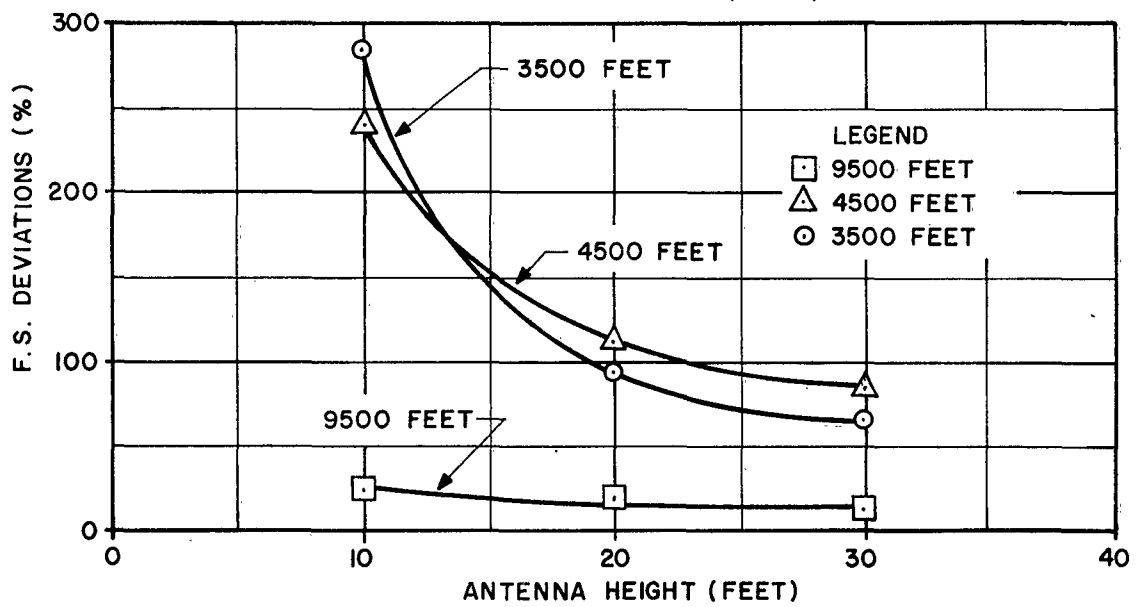
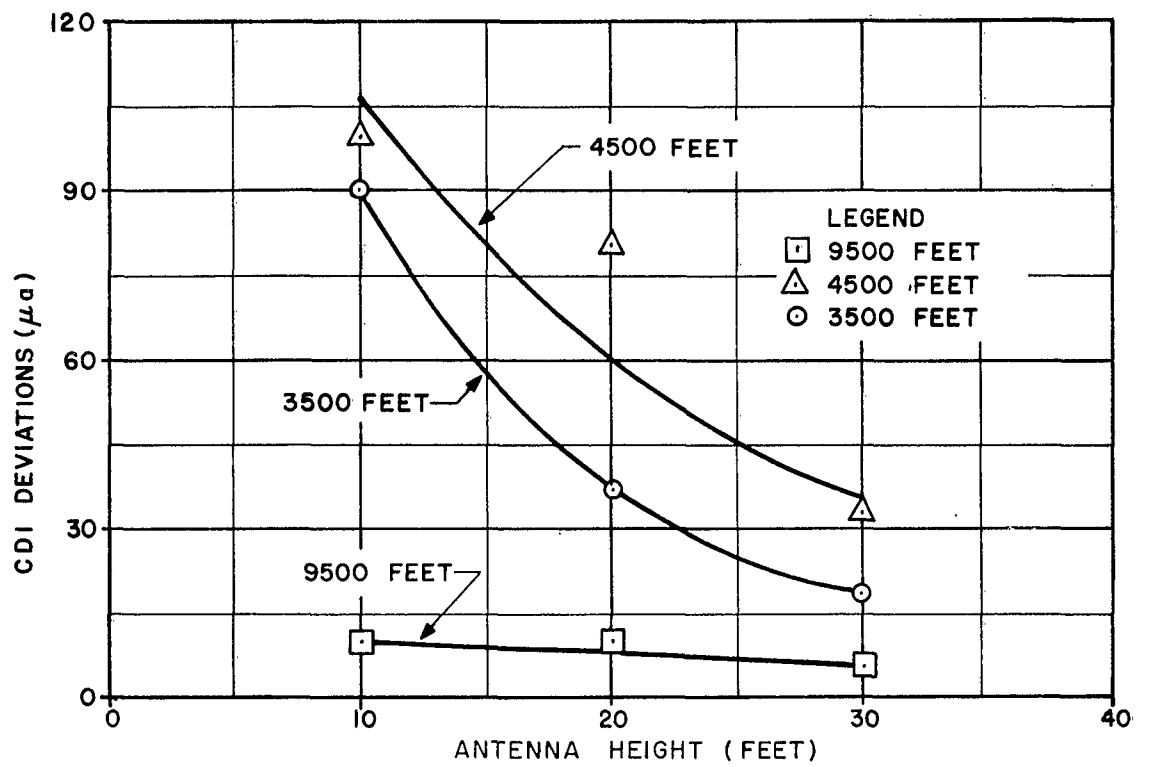

FIG. 9 TEST 2, CDI AND FS DEVIATIONS VERSUS ANTENNA HEIGHTS

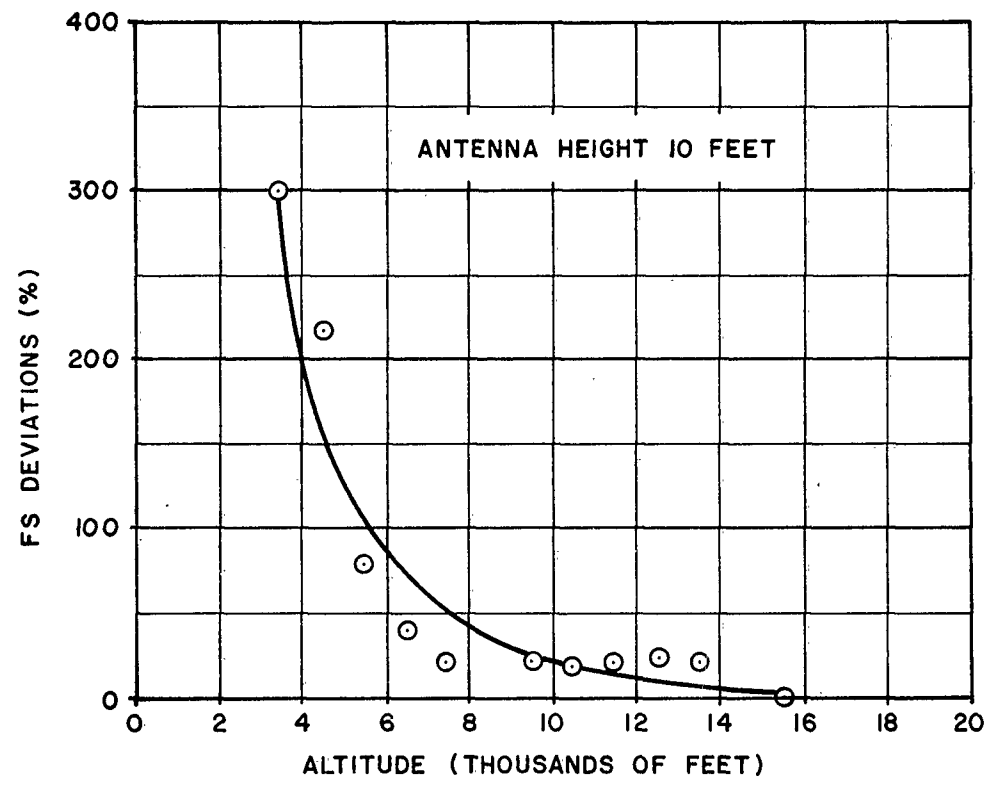
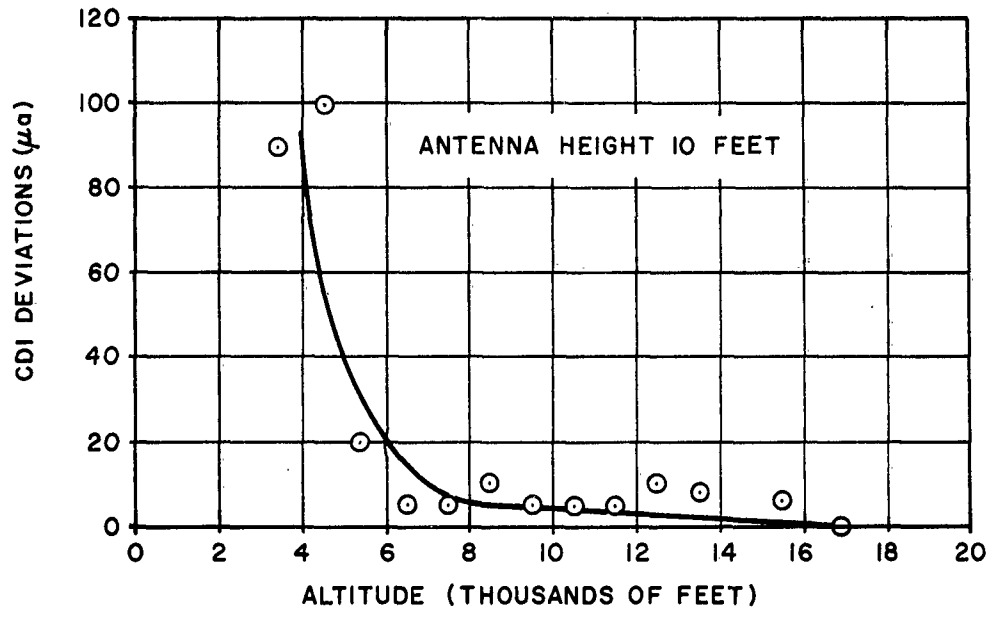
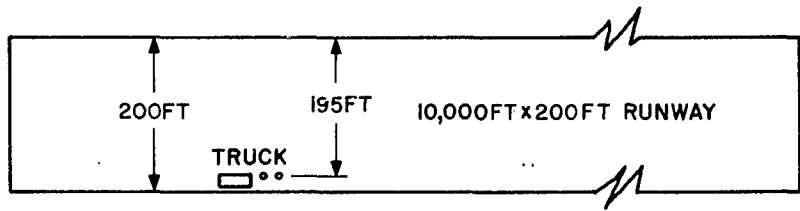
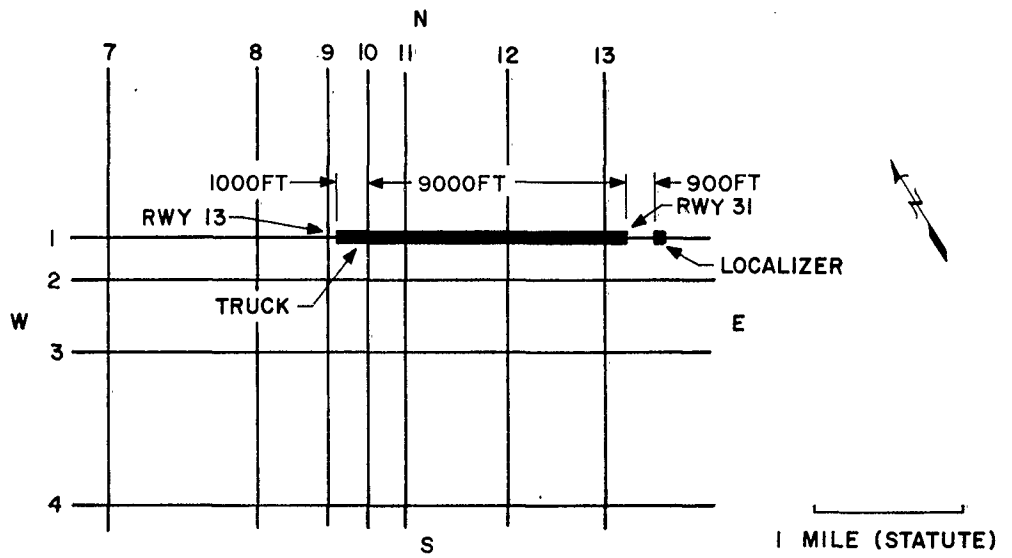
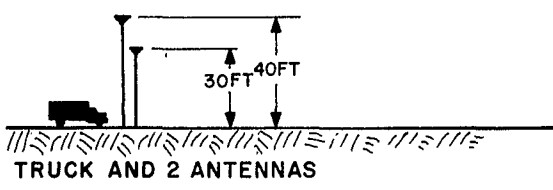

FIG. 10 TEST 2, CDI AND FS DEVIATIONS VERSUS ALTITUDE



PROGRAM

ALTITUDE	TRACK NO.	
	12 N-S	12 S-N
2000FT	X X	
3000FT	X	X
5000FT	X	X



HELICOPTER FLEW ACROSS RUNWAY,  
3700 FEET FROM THE LOCALIZER  
(APPROXIMATELY TRACK 12).

FIG. 11 TEST 3 GEOMETRY

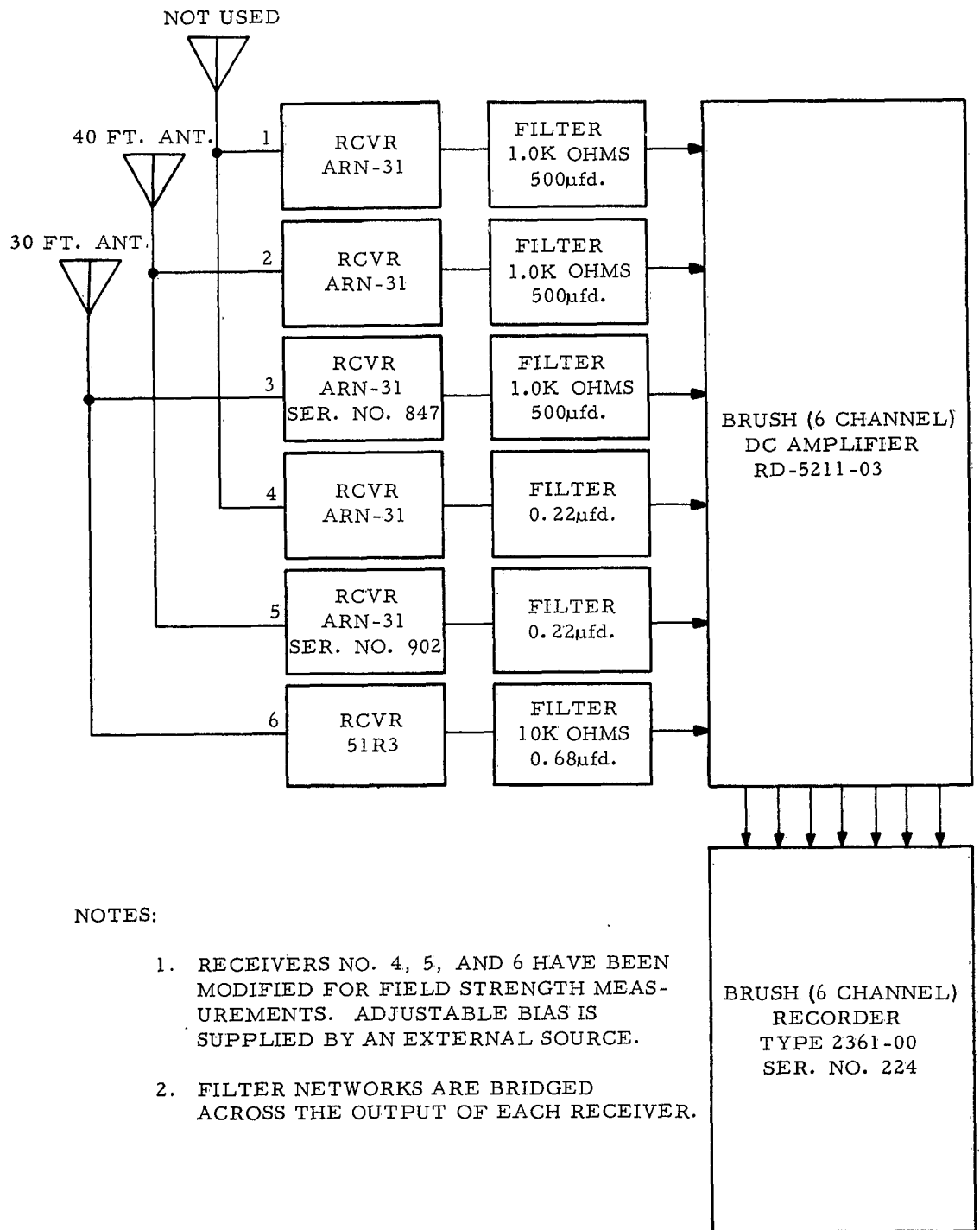
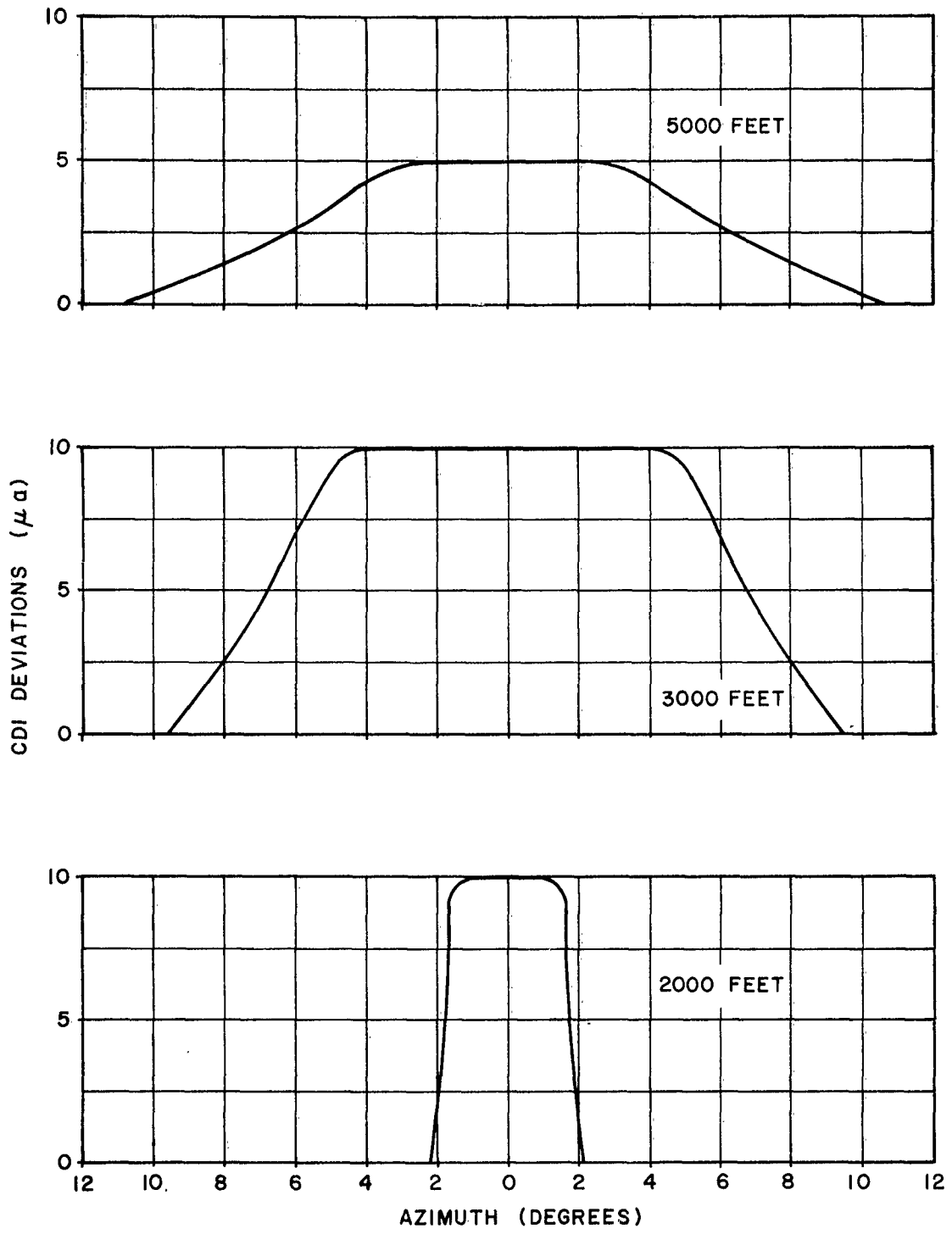
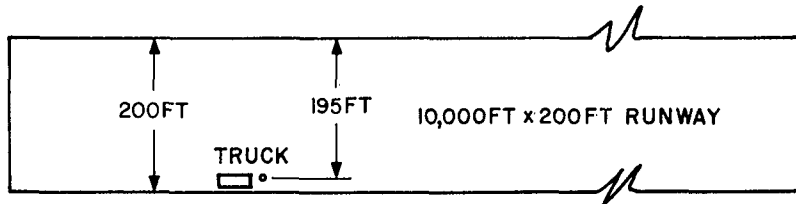
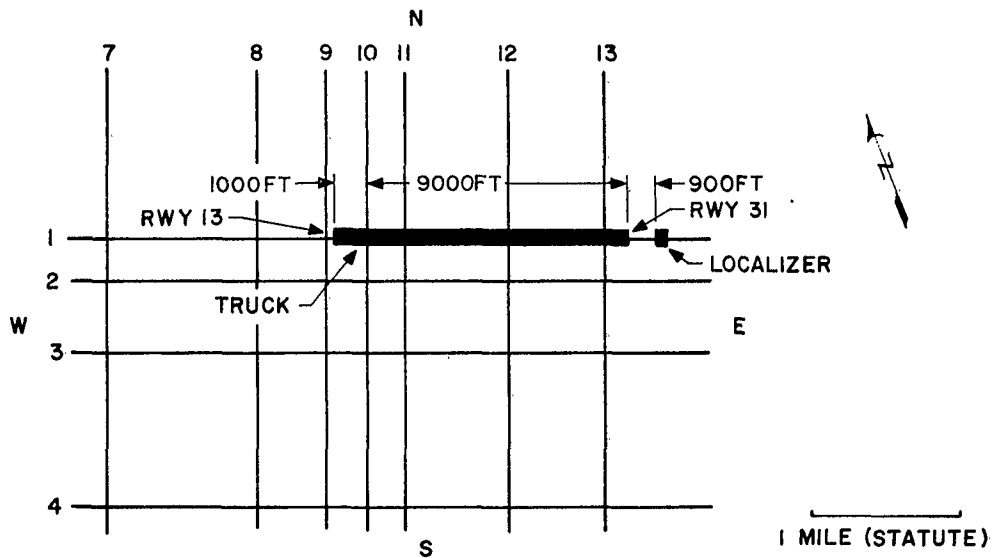

FIG. 12 TEST 3 RECORDING SETUP



ANTENNA HEIGHT 30 FEET

FIG. 13 TEST 3, CDI DEVIATIONS VERSUS AZIMUTH



PROGRAM

ALTITUDE	TRACK NO. 1
1000FT	X
2000FT	X
4000FT	X
6000FT	X
8000FT	X

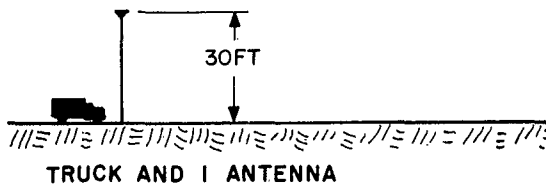

FIG. 14 TEST 4 GEOMETRY

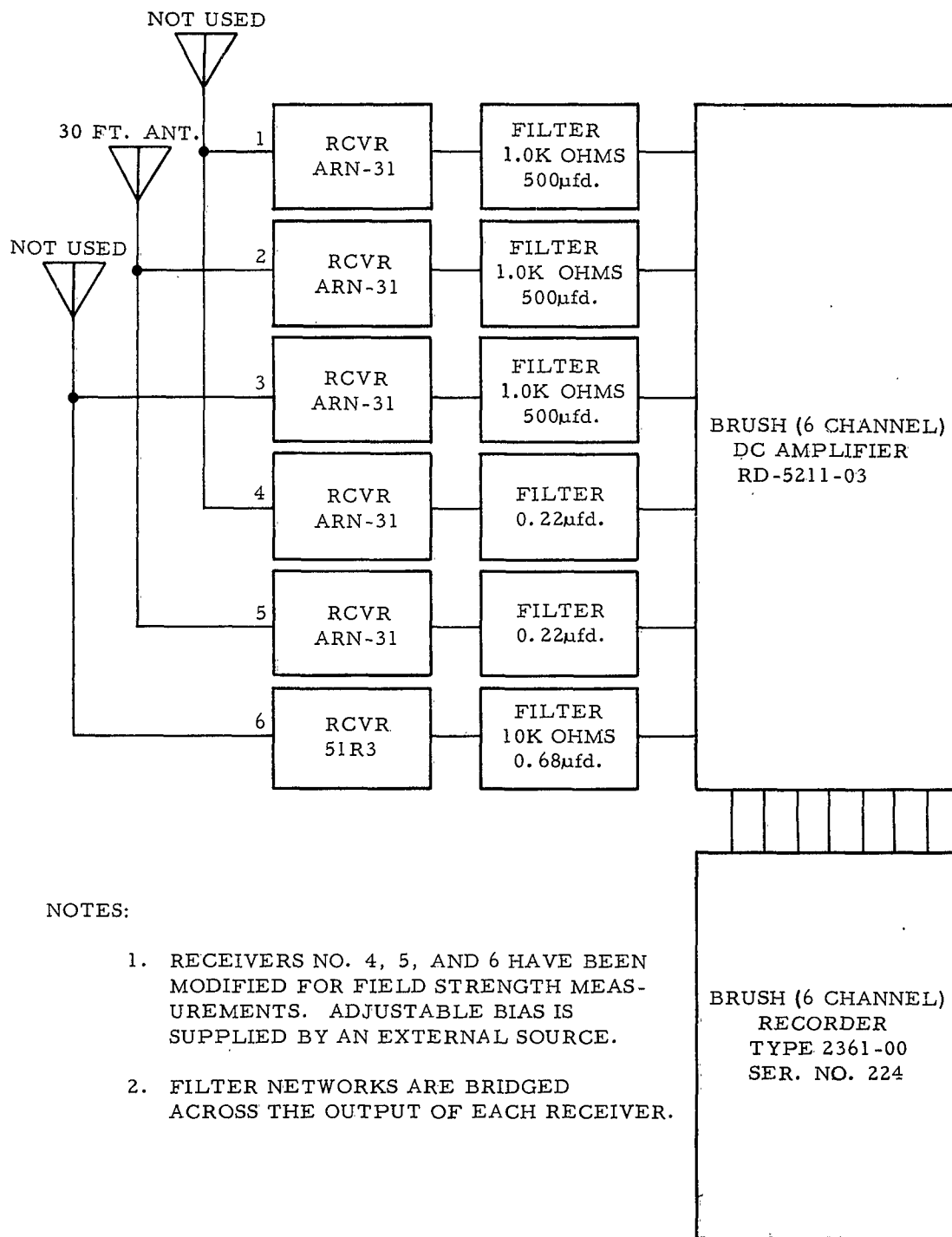

FIG. 15 TEST 4 RECORDING SETUP

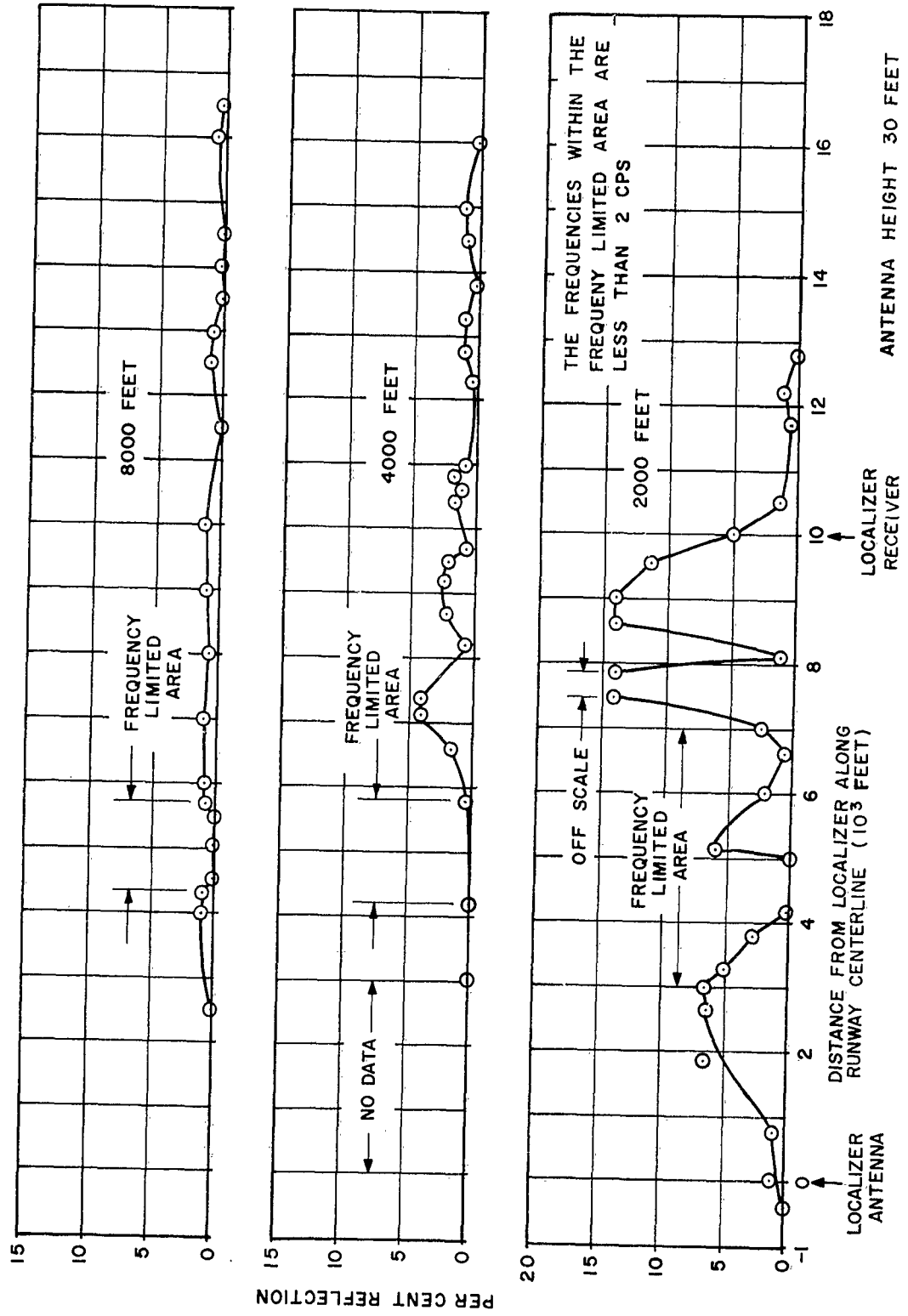
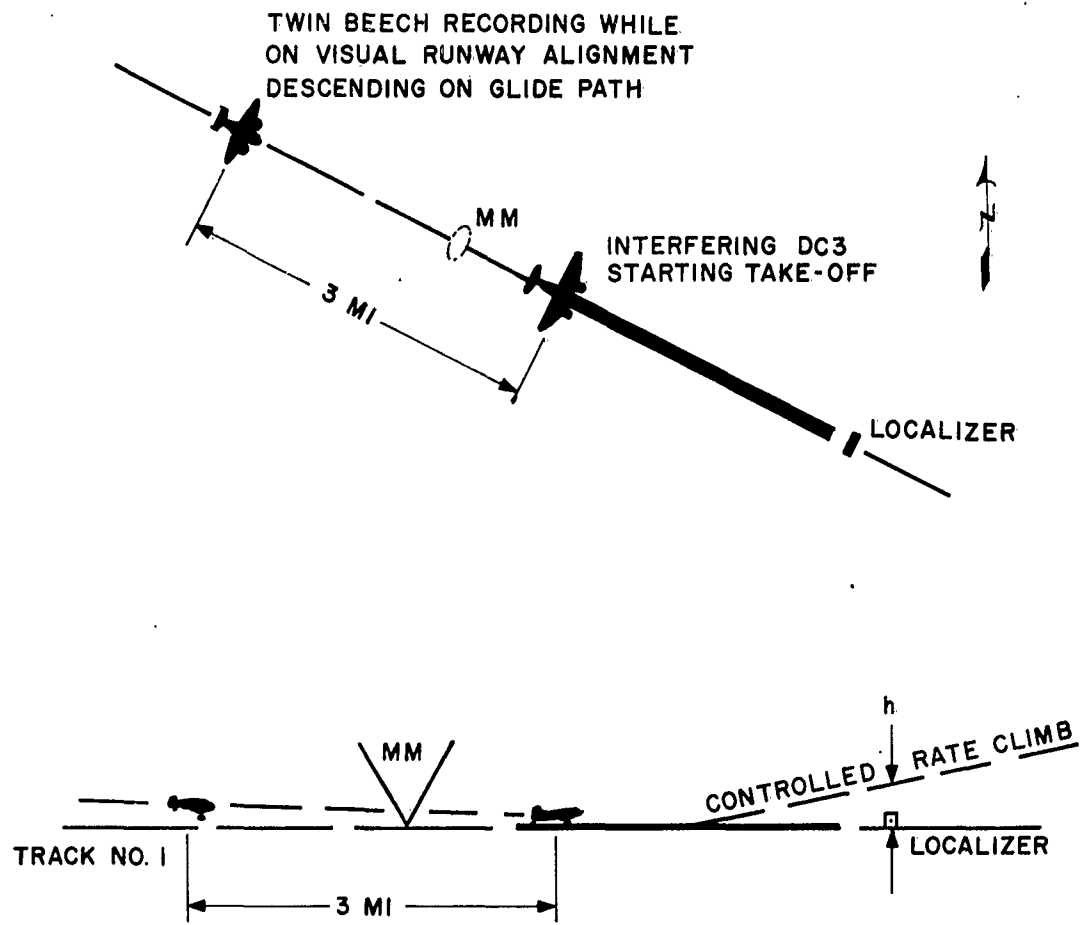

FIG. 16 TEST 4, PER CENT REFLECTION VERSUS DISTANCE FROM LOCALIZER



TRACK NO. 1 PROGRAM

ALTITUDE OF DC3 OVER LOCALIZER	
100FT	XXX
200FT	XX

EACH X INDICATES 1 RUN

FIG. 17 TEST 5 GEOMETRY

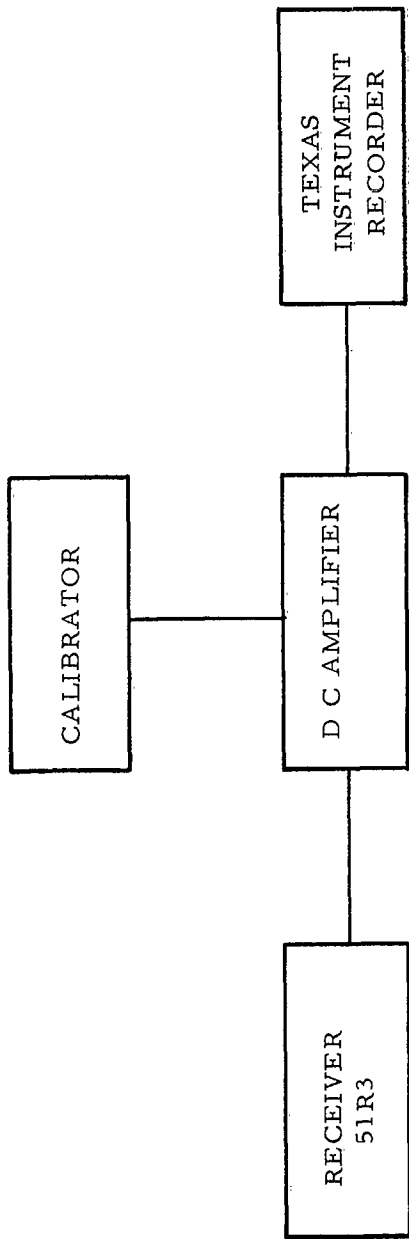

FIG. 18 TEST 5 RECORDING SETUP

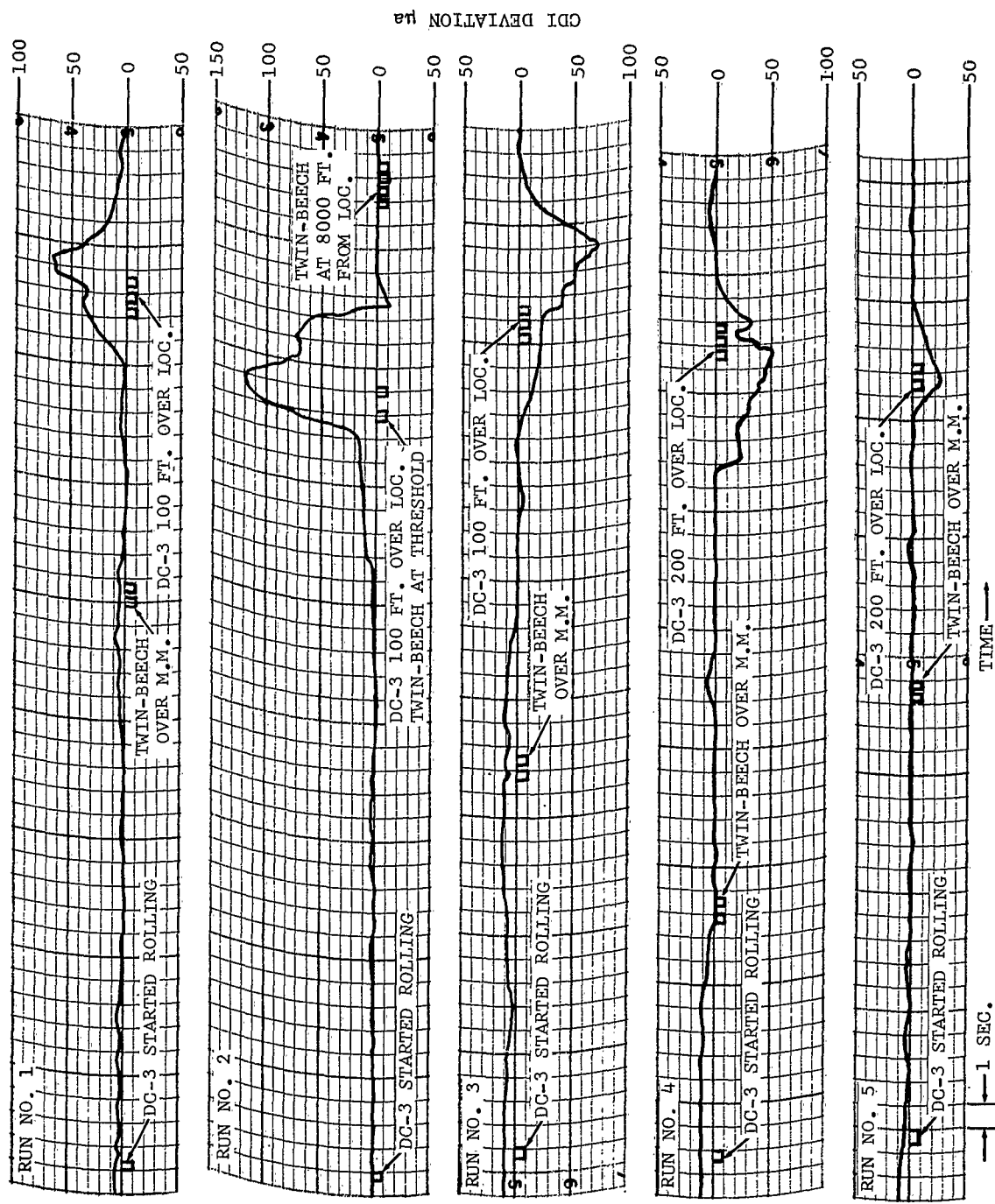
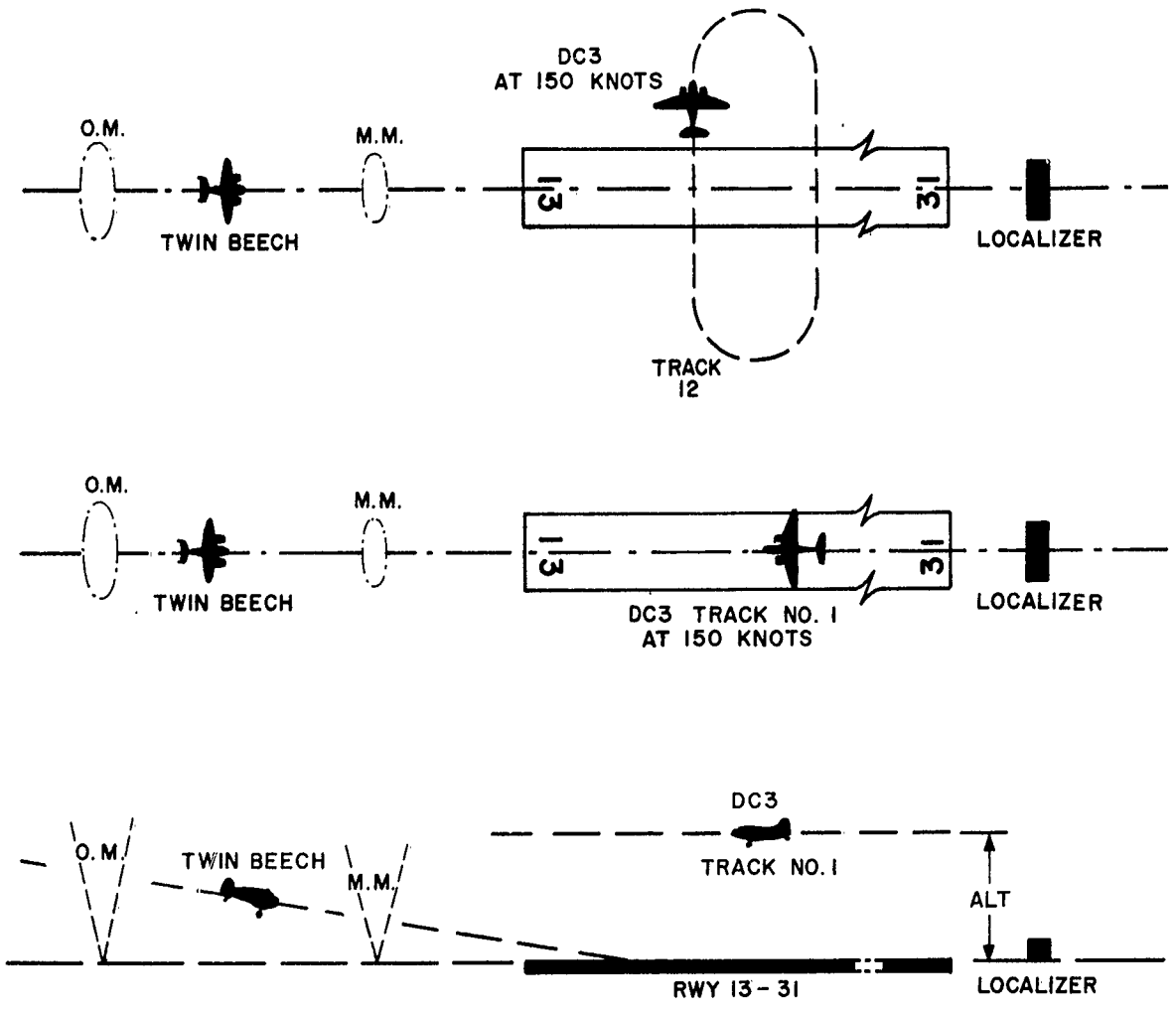

FIG. 19 TEST 5 INTERFERENCE PATTERNS



PROGRAM

ALTITUDE	TRACK NO.	
	12	1
2000FT	XX	XX
3000FT		X
4500FT		X

EACH X INDICATES 1 RUN

FIG. 20 TEST 6 GEOMETRY

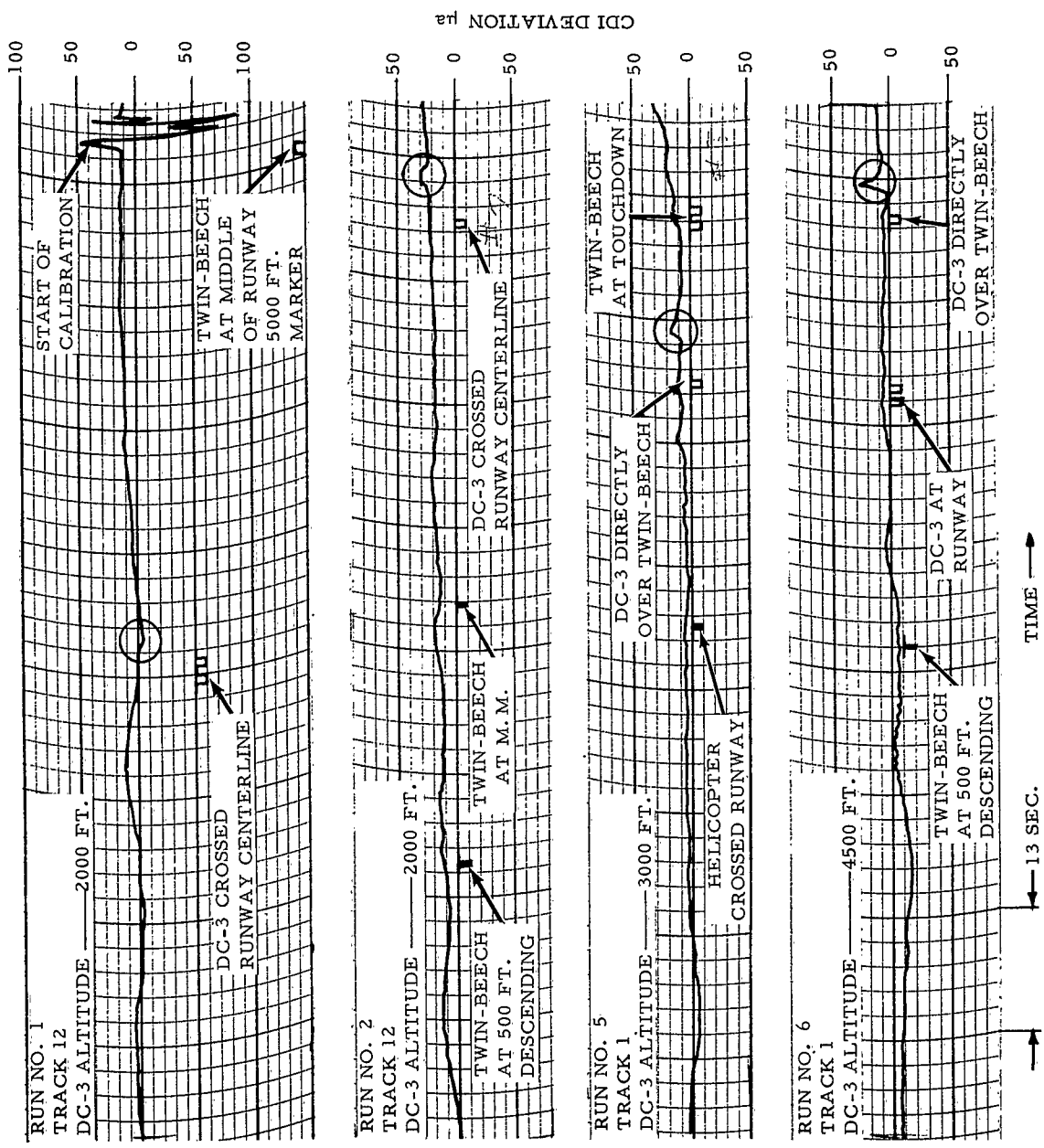
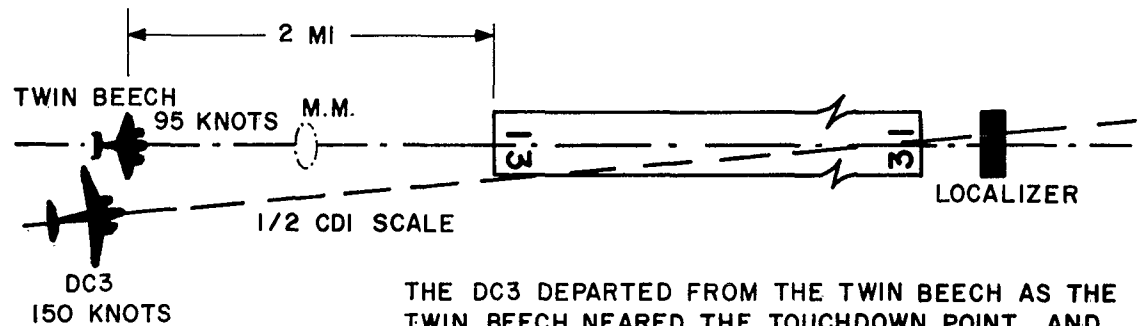
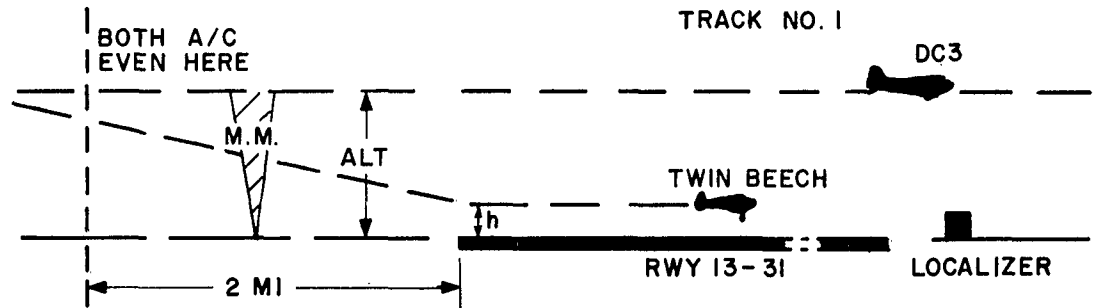

FIG. 21 TEST 6 INTERFERENCE PATTERNS



THE DC3 DEPARTED FROM THE TWIN BEECH AS THE TWIN BEECH NEARED THE TOUCHDOWN POINT, AND FLEW OVER THE LOCALIZER

TRACK NO. 1  
PROGRAM

ALT \ h	50 FT	100 FT	200 FT	300 FT
1000 FT	X	X	X	X
2000 FT	XX	XXX	X	

EACH X INDICATES 1 RUN

FIG. 22 TEST 7 GEOMETRY

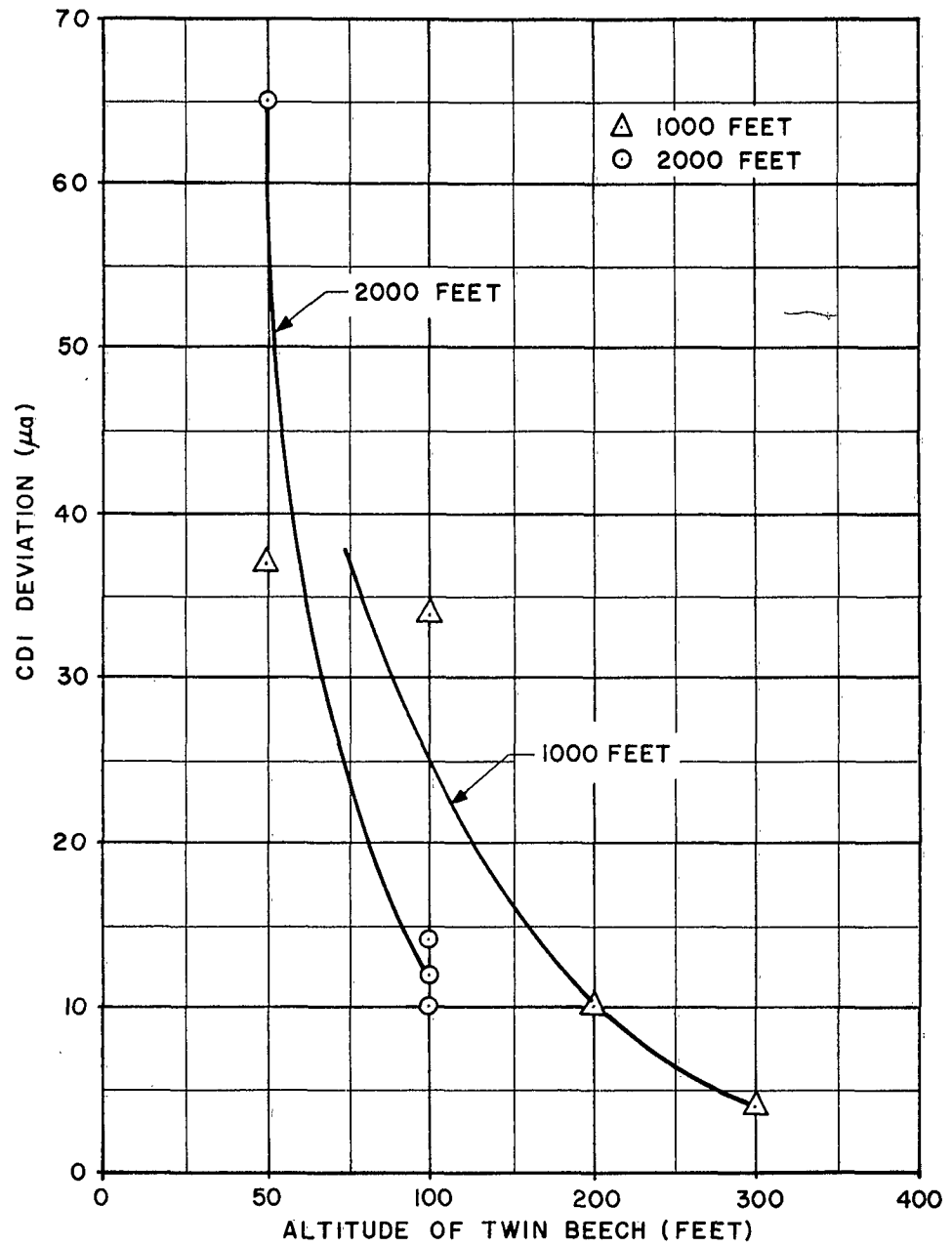
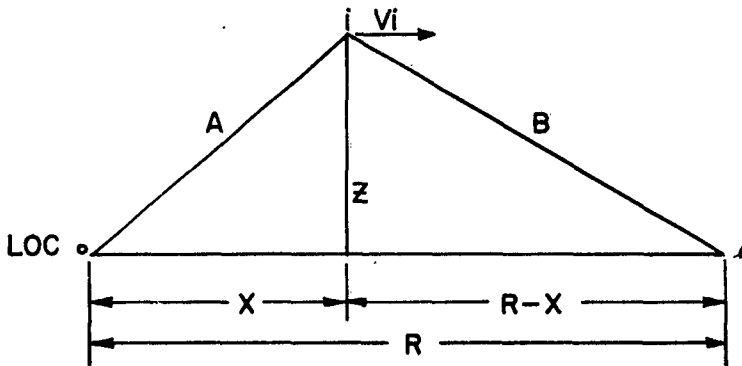

FIG. 23 TEST 7 CDI DEVIATIONS VERSUS ALTITUDE OF AIRCRAFT OVER LOCALIZER ANTENNA



$$\text{PATH LENGTH DIFFERENCE} = P = A + B - R \quad 24-1$$

$$P = (z^2 + X^2)^{1/2} + [z^2 + (R-X)^2]^{1/2} - R \quad 24-2$$

$$P = [z^2 + (V_i \cdot t)^2]^{1/2} + [z^2 + (R - V_i \cdot t)^2]^{1/2} - R \quad 24-3$$

$$\text{where } X = V_i \cdot t \quad 24-4$$

$$\frac{dP}{dt} = (V_i)^2 \cdot t [z^2 + (V_i \cdot t)^2]^{-1/2} - V_i (R - V_i \cdot t) [z^2 + (R - V_i \cdot t)^2]^{-1/2} \quad 24-5$$

$$\frac{dP}{dt} = (V_i) \cdot X [z^2 + X^2]^{-1/2} - V_i (R - X) [z^2 + (R - X)^2]^{-1/2} \quad 24-6$$

$$f = \text{FREQUENCY OF INTERFERENCE} = \frac{dP}{dt} \cdot \frac{1}{\lambda} \quad 24-7$$

FIG. 24 CASE SL GEOMETRY

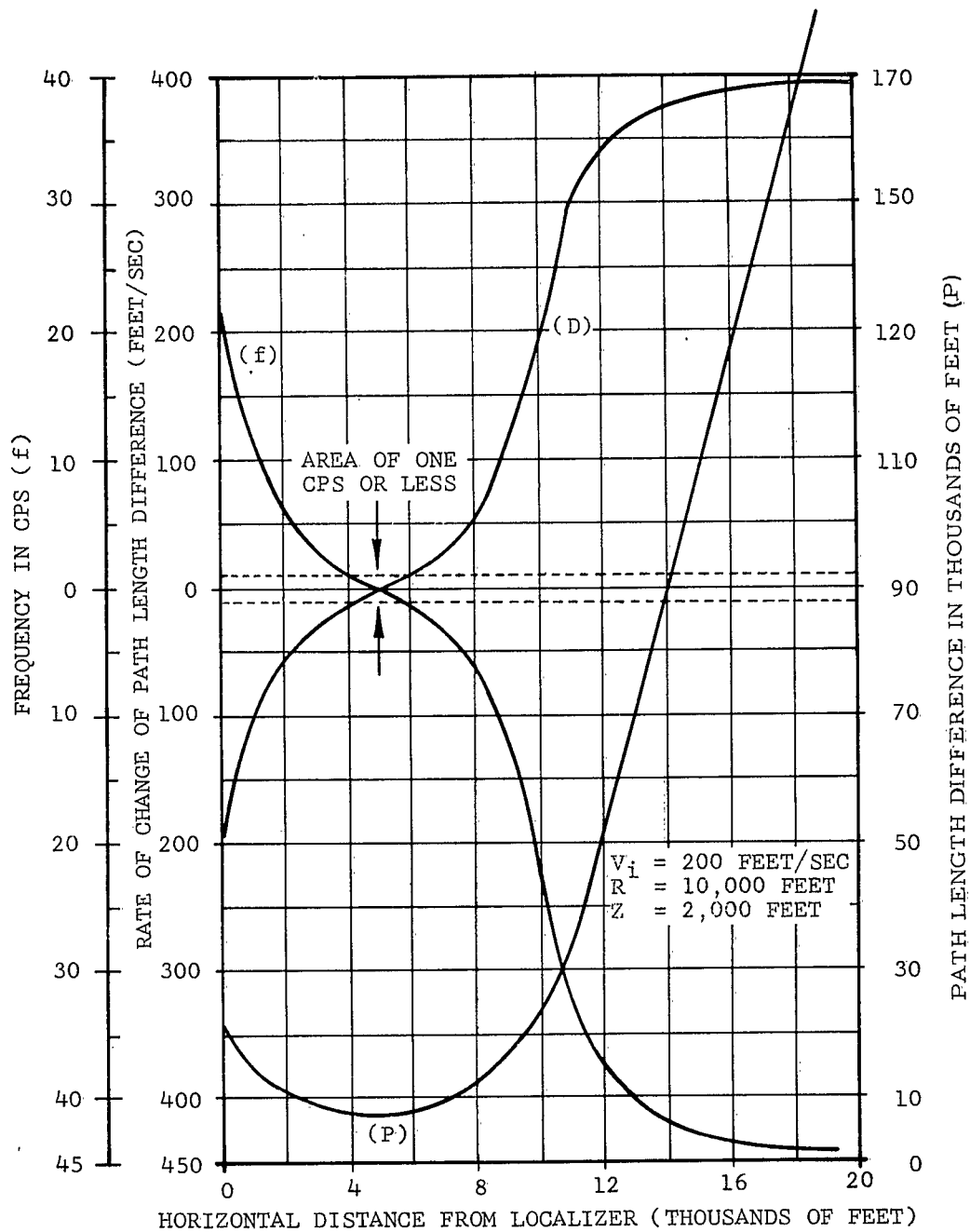
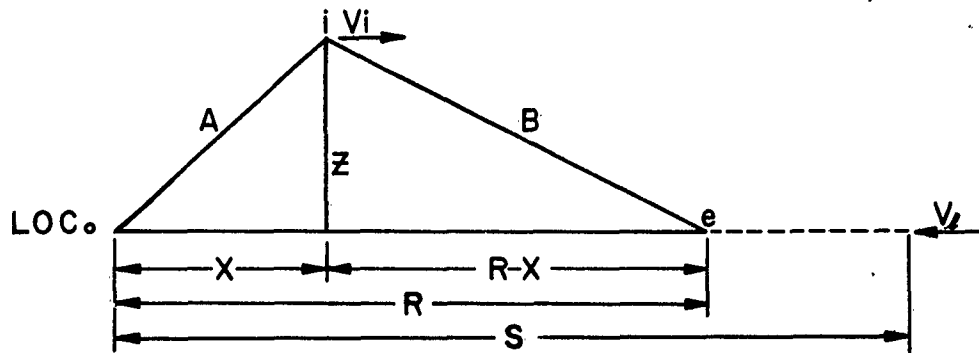

FIG. 25 CASE SL - P, D, AND F VERSUS DISTANCE FROM LOCALIZER



$$\text{PATH LENGTH DIFFERENCE} = P = A + B - R \quad 26-1$$

$$P = [z^2 + X^2]^{1/2} + [z^2 + (R-X)^2]^{1/2} - R \quad 26-2$$

$$P = [z^2 + (Vi \cdot t)^2]^{1/2} + [z^2 + (S - V_e \cdot t - Vi \cdot t)^2]^{1/2} - (S - V_e \cdot t) \quad 26-3$$

$$\text{WHERE } [R = S - V_e \cdot t] \quad 26-4$$

$$\text{AND } [X = Vi \cdot t] \quad 26-5$$

$$\frac{dP}{dt} = (Vi)^2 \cdot t [z^2 + (Vi \cdot t)^2]^{-1/2} - (S - V_e \cdot t - Vi \cdot t)(V_e + Vi) [z^2 + (S - V_e \cdot t - Vi \cdot t)^2]^{-1/2} + V_e \quad 26-6$$

$$\frac{dP}{dt} = Vi \cdot X [z^2 + X^2]^{-1/2} - (R-X)(V_e + Vi) [z^2 + (R-X)^2]^{-1/2} + V_e \quad 26-7$$

$$f = \text{FREQUENCY OF INTERFERENCE} = \frac{dP}{dt} \cdot \frac{1}{\lambda} \quad 26-8$$

FIG. 26 DL GEOMETRY

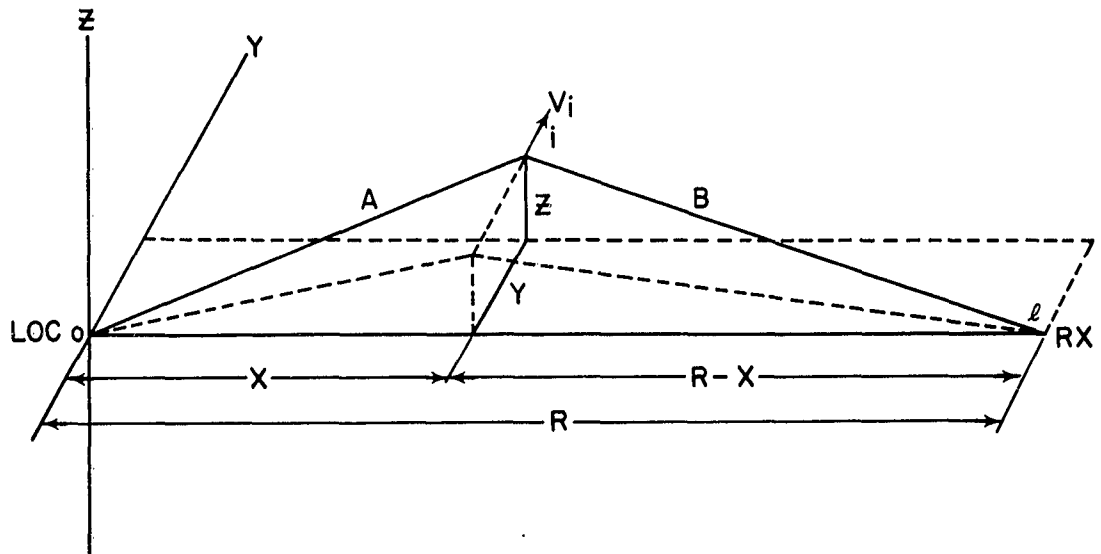

$$\text{PATH LENGTH DIFFERENCE} = P = A + B - R \quad 27-1$$

$$P = (Z^2 + Y^2 + X^2)^{1/2} + [Z^2 + Y^2 + (R - X)^2]^{1/2} - R \quad 27-2$$

$$P = [Z^2 + (V_i \cdot t)^2 + X^2]^{1/2} + [Z^2 + (V_i \cdot t)^2 + (R - X)^2]^{1/2} - R \quad 27-3$$

$$\text{where } Y = V_i \cdot t \quad 27-4$$

$$\frac{dP}{dt} = (V_i)^2 \cdot t [Z^2 + (V_i \cdot t)^2 + X^2]^{-1/2} + (V_i)^2 \cdot t [Z^2 + (V_i \cdot t)^2 + (R - X)^2]^{-1/2} \quad 27-5$$

$$\frac{dP}{dt} = Y(V_i) [Z^2 + Y^2 + X^2]^{-1/2} + Y(V_i) [Z^2 + Y^2 + (R - X)^2]^{-1/2} \quad 27-6$$

$$f = \text{FREQUENCY OF INTERFERENCE} = \frac{dP}{dt} \cdot \frac{1}{\lambda}$$

FIG. 27 ST GEOMETRY



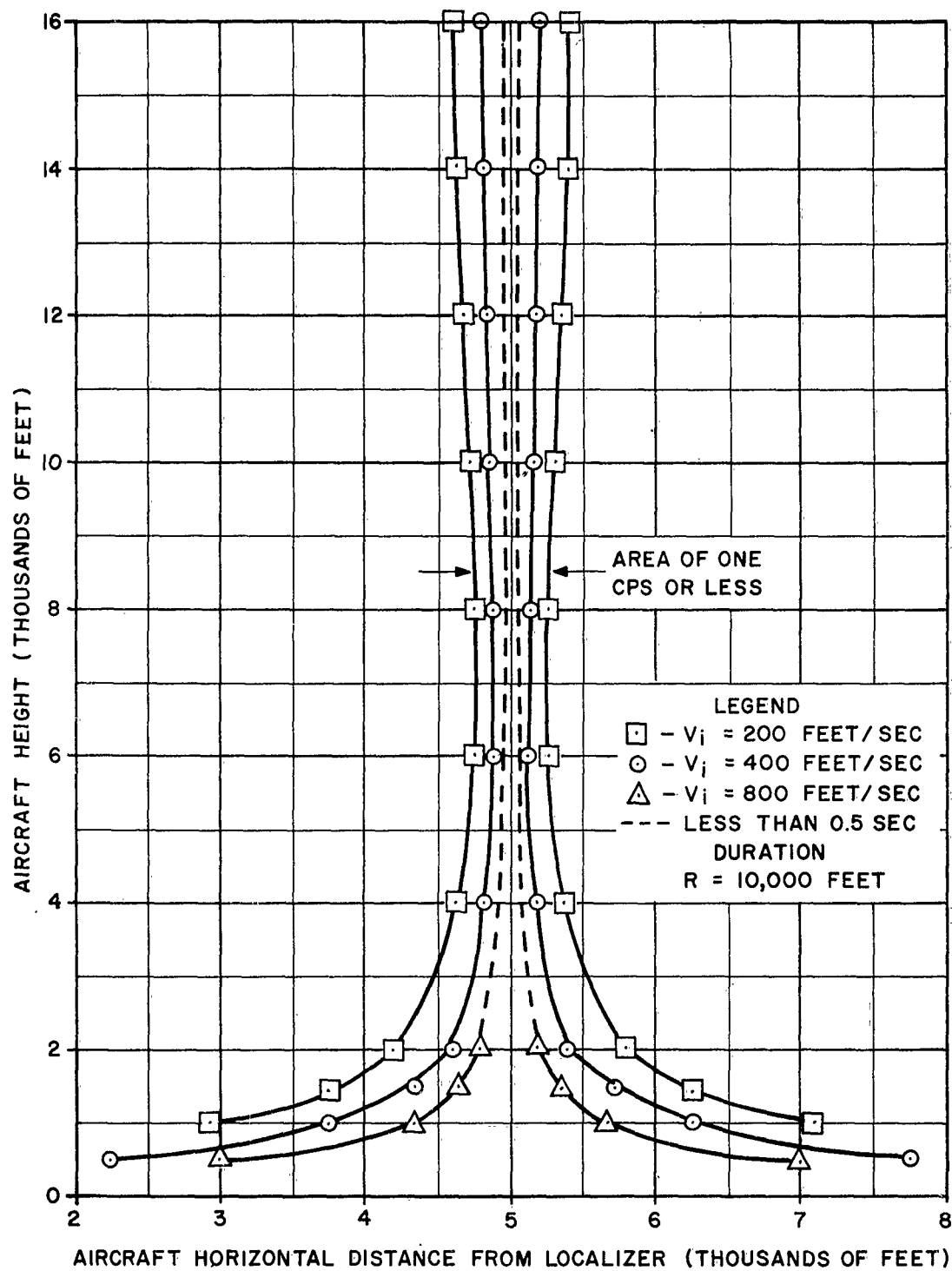

FIG. 29 SL PROFILE

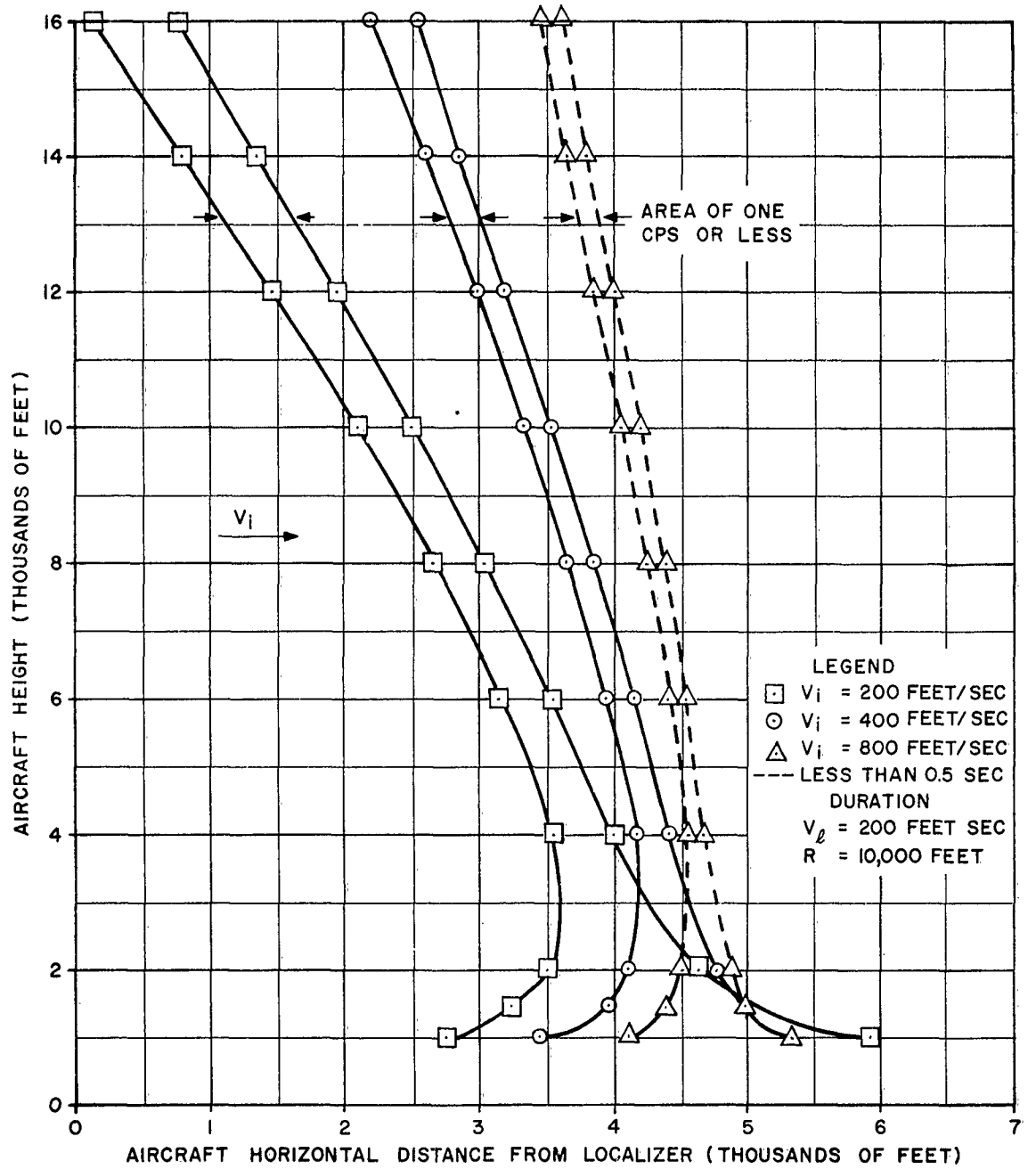

FIG. 30 DL (1) PROFILE

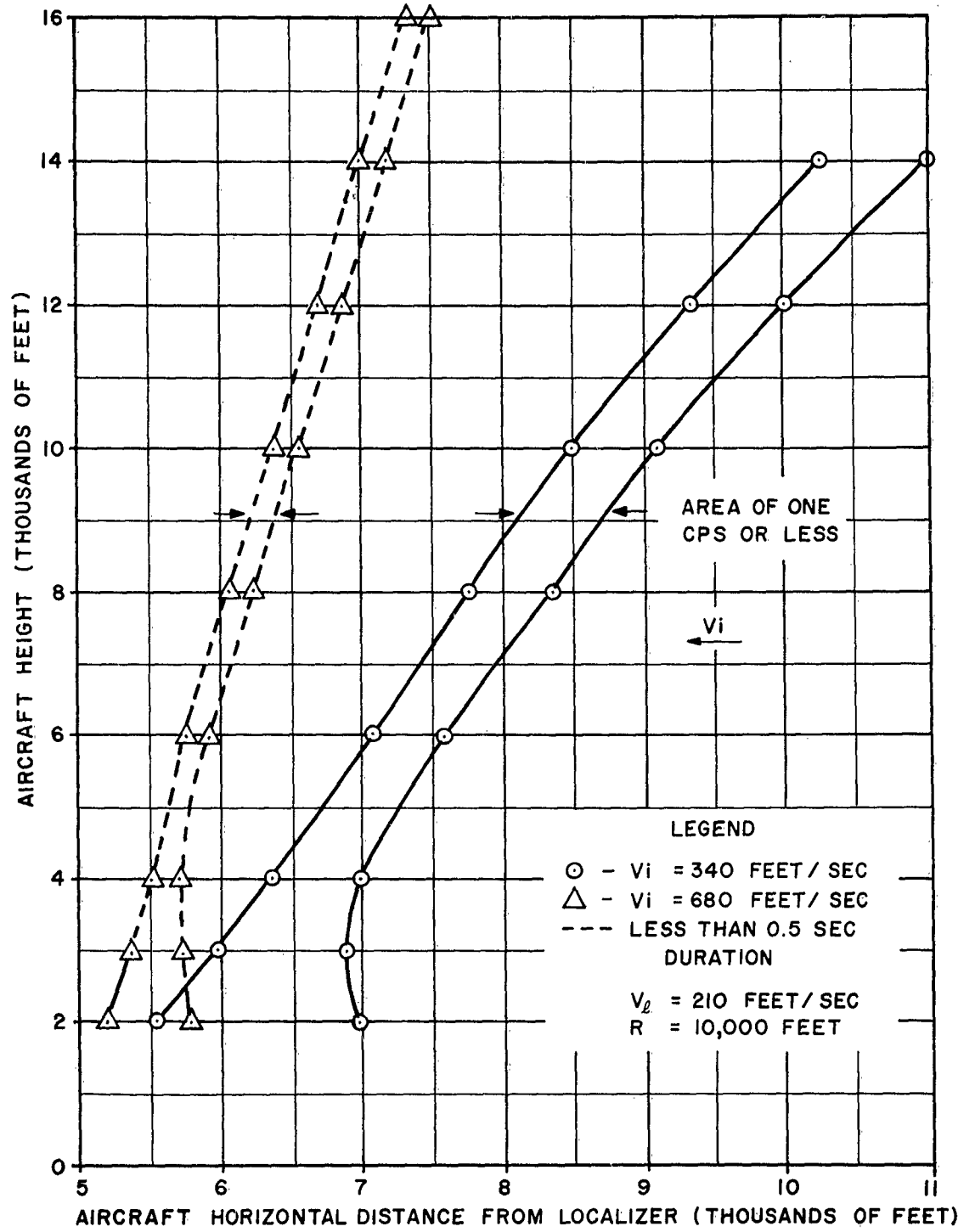

FIG. 31 DL (2) PROFILE

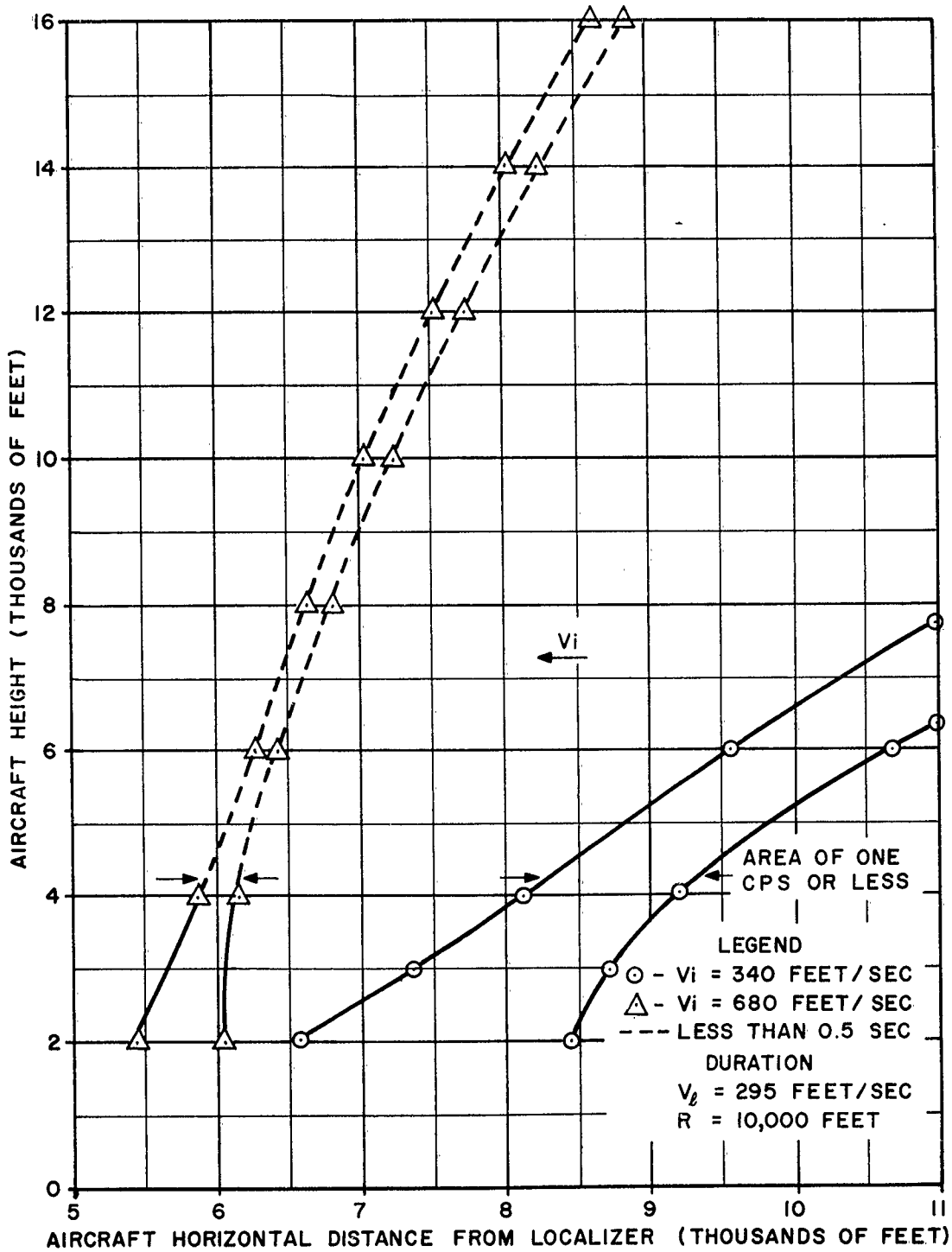

FIG. 32 DL (3) PROFILE

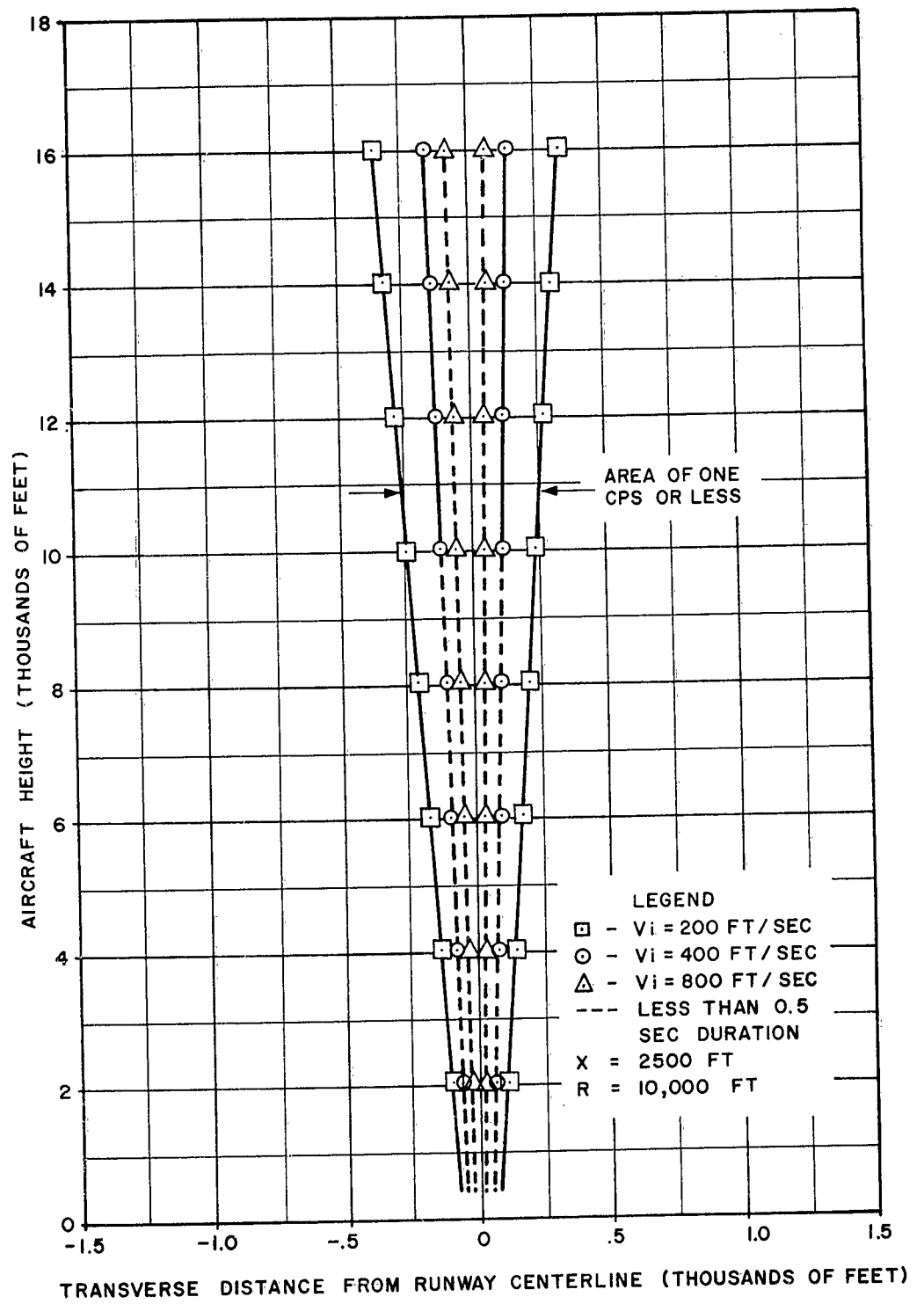

FIG. 33 ST (I) PROFILE

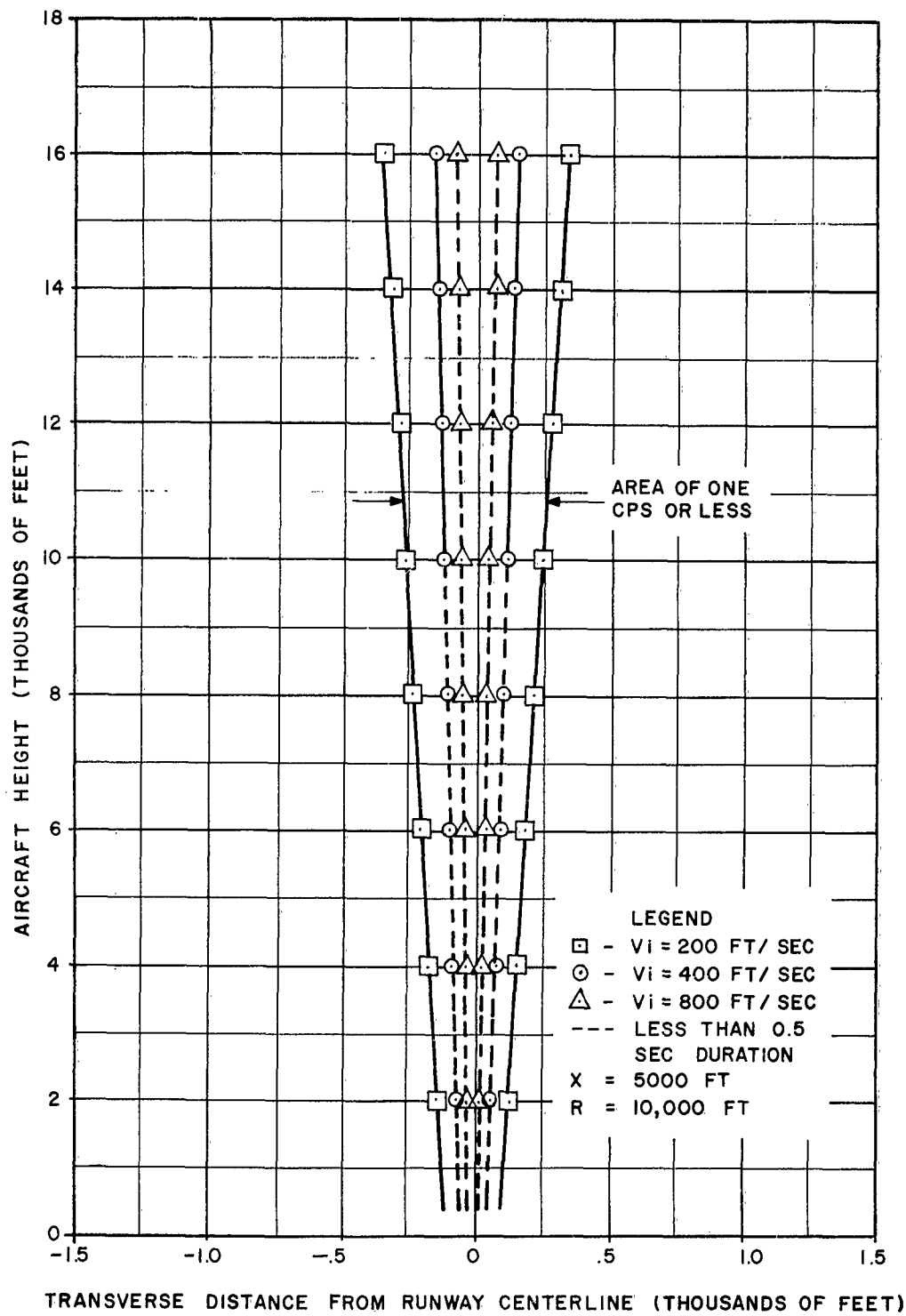

FIG. 34 ST (2) PROFILE

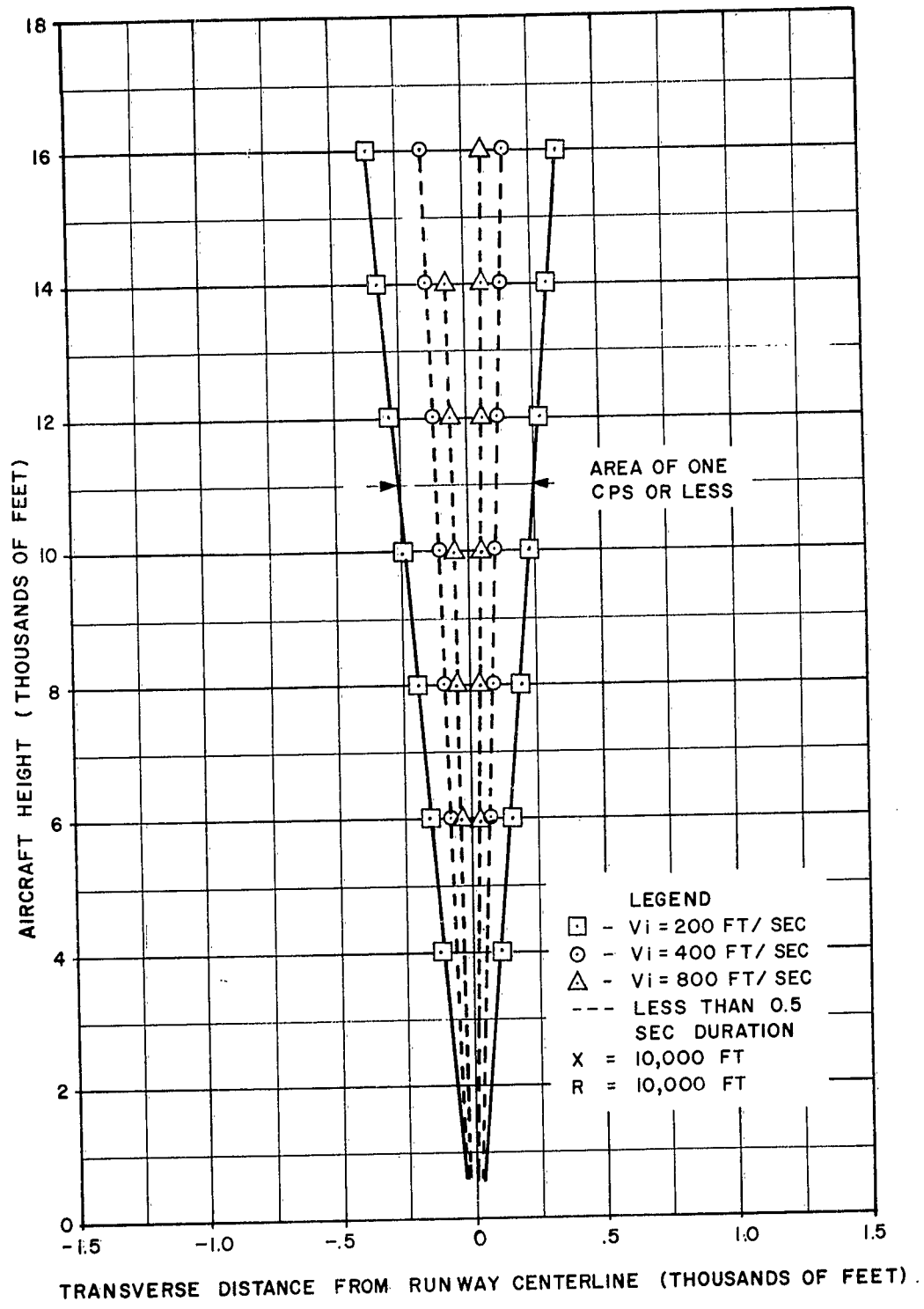

FIG. 35 ST (3) PROFILE

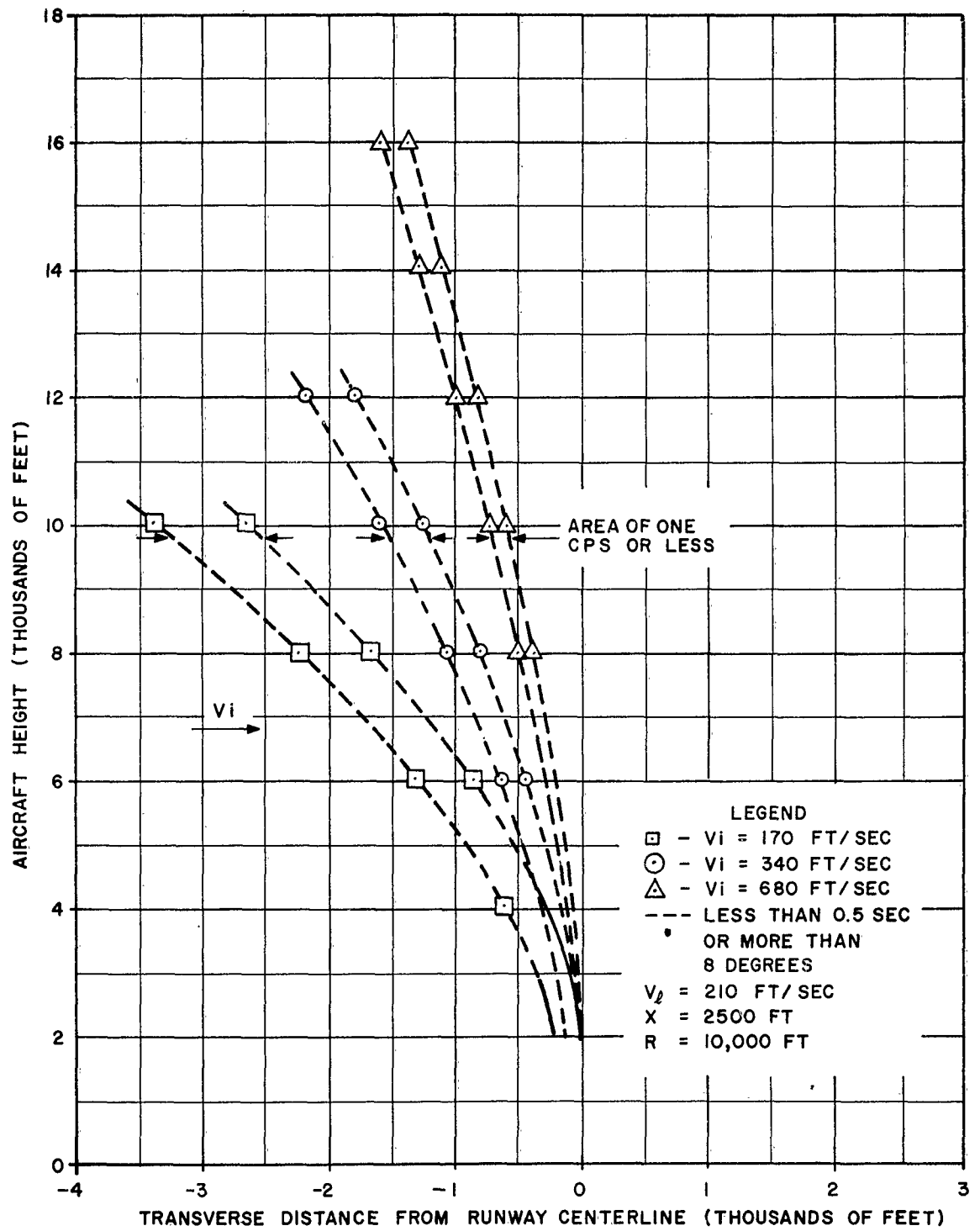

FIG. 36 DT (1) PROFILE

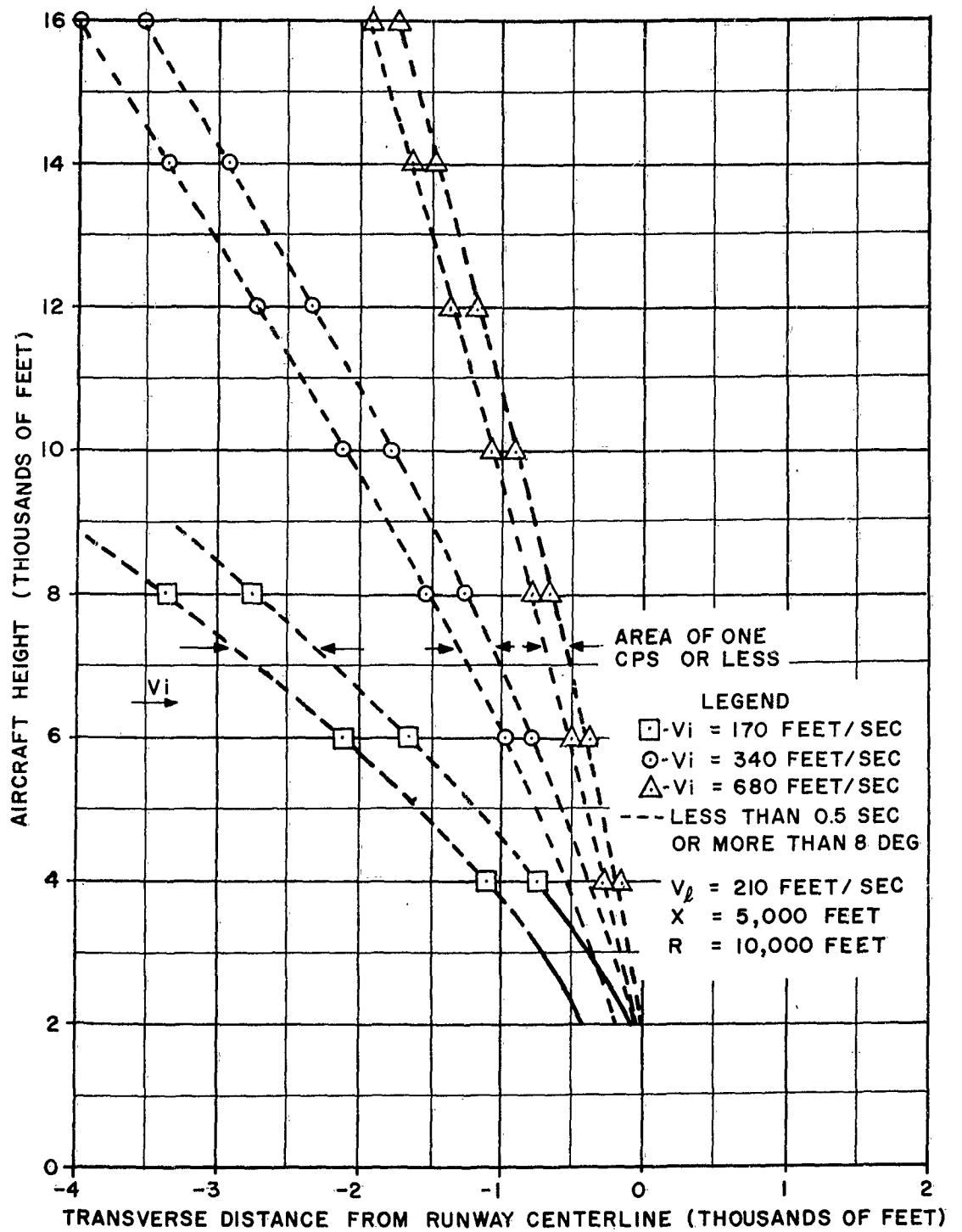

FIG. 37 DT (2) PROFILE

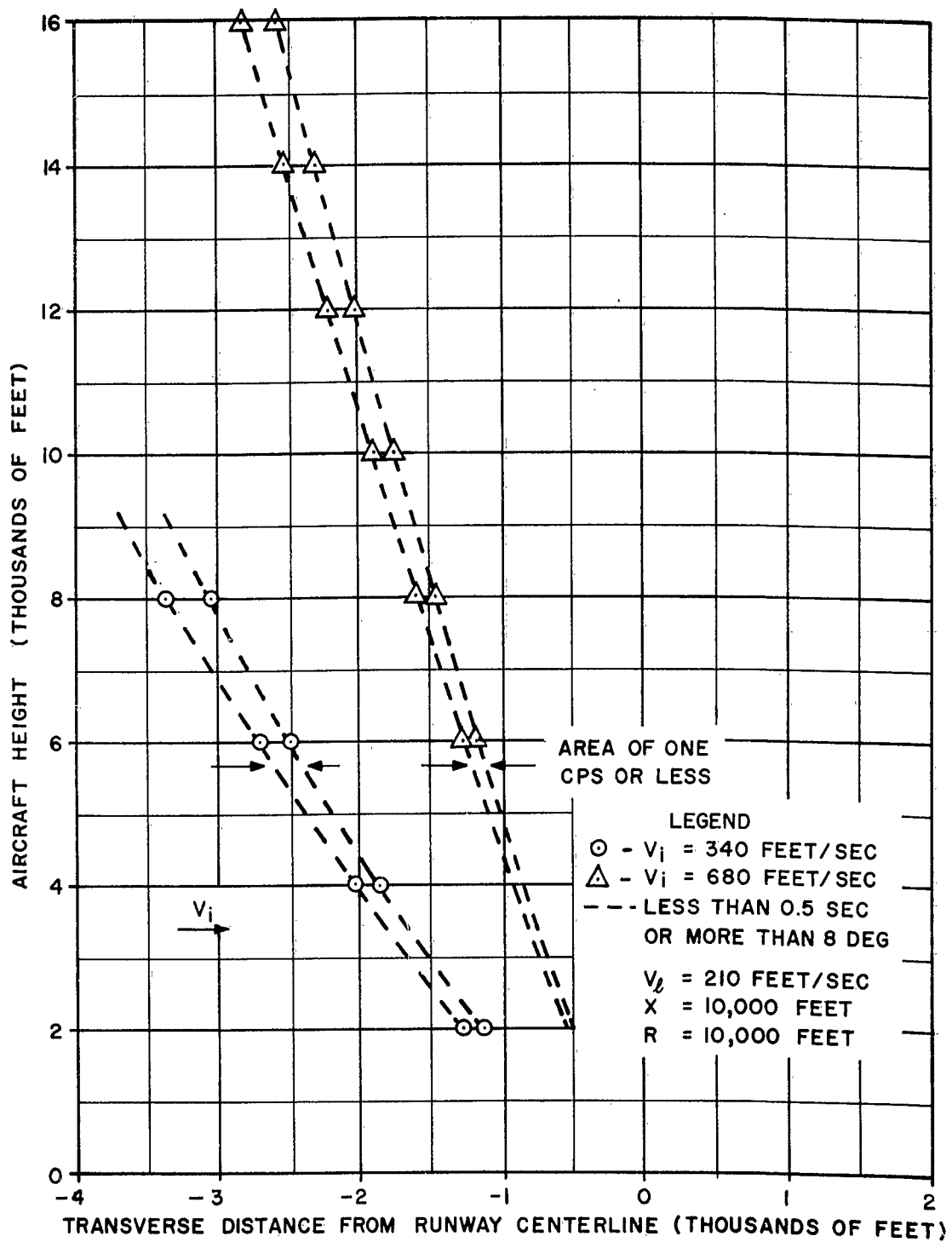

FIG. 38 DT (3) PROFILE