

UNCLASSIFIED

AD **407 342**

DEFENSE DOCUMENTATION CENTER

FOR

SCIENTIFIC AND TECHNICAL INFORMATION

CAMERON STATION, ALEXANDRIA, VIRGINIA



UNCLASSIFIED

NOTICE: When government or other drawings, specifications or other data are used for any purpose other than in connection with a definitely related government procurement operation, the U. S. Government thereby incurs no responsibility, nor any obligation whatsoever; and the fact that the Government may have formulated, furnished, or in any way supplied the said drawings, specifications, or other data is not to be regarded by implication or otherwise as in any manner licensing the holder or any other person or corporation, or conveying any rights or permission to manufacture, use or sell any patented invention that may in any way be related thereto.

CATALOGED BY DDC

AS AD No. 407342

407 342

DATA DISPLAY STUDY

First Quarterly Report
1 December 1962 to March 1963
Report Number 1

Contract No. DA-36-039 SC-90855
U.S. Army Signal Research and Development Laboratory
Fort Monmouth, New Jersey

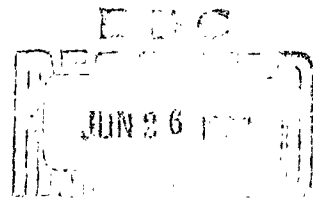

NCR

THE NATIONAL CASH REGISTER COMPANY
ELECTRONICS DIVISION
2815 West El Segundo Boulevard
Hawthorne, California

NO OTS

DATA DISPLAY STUDY

QUARTERLY REPORT NO. 1
1 December 1962 to 1 March 1963
Contract No. DA-36-039 SC-90855

Prepared In Accordance with
Signal Corps Technical Requirements
NO. SCL-2101N, Dated 1 February 1961

BY
H.L. BJELLAND

ASTIA AVAILABILITY NOTICE

QUALIFIED REQUESTORS MAY OBTAIN COPIES
OF THIS REPORT FROM ASTIA. ASTIA RELEASE
TO OTS NOT AUTHORIZED.

NCR-ED TECHNICAL PUBLICATION NO. 3520

TABLE OF CONTENTS

	Page
1. PURPOSE	1
2. ABSTRACT	1
3. REPORTS AND CONFERENCES	1
4. FACTUAL DATA	3
4.1 DISCUSSION OF DISPLAY PARAMETERS	3
4.1.1 Intelligence Display	4
4.1.2 Artillery Display	7
4.1.3 Comparison of Displays	9
4.2 PHOTOCROMIC PROPERTIES	13
4.3 PHOTOCROMIC DISPLAY CONFIGURATIONS	14
4.3.1 Composite Projection Channel	15
4.3.2 Writing Method	16
4.3.3 Persistence	16
4.3.4 Erasure	16
4.4 PHOTOCROMIC MATERIALS TEST PROGRAM	17
4.4.1 Photochromic Materials Tester	17
4.4.2 Range of Persistency in Photochromic Materials	18
4.4.3 Temperature Tests	20
4.4.4 Incident Illumination Tests	20
4.4.5 Photochromic Area Considerations	23
4.5 EXISTING DISPLAY EQUIPMENT	24
4.5.1 X-Y Mechanism	24
4.5.2 Cursor Mechanism	26
4.5.3 Photochromic Plate Changer	26
4.5.4 Packaging Design	27
4.5.5 U.S. Navy Display System	29
4.6 STATE-OF-THE-ART DISPLAY ADVANCEMENTS	30
4.7 WEDGE SYSTEM	31
4.7.1 Theoretical Discussion of Wedge System	32
4.7.2 System Advantages	35
4.7.3 System Disadvantages	36

TABLE OF CONTENTS (CONT)

	Page
4.7.4 Off-Axis Writing Method	36
4.7.5 On-Axis Writing Method	37
4.7.6 Comparison of Writing Speed	38
4.7.7 Future Systems	39
4.8 CRT FIBER-OPTIC PHOTOCROMIC DISPLAY	39
4.8.1 CRT Photochromic Writing Techniques	40
4.8.2 Fiber-Optic Cathode-ray Tube Tests	40
4.8.3 Preliminary System Design	42
4.8.4 Magnetic Deflection	43
4.8.5 Electrostatic Deflection	44
4.8.6 Deflection Choice	44
4.8.7 Accuracy and Repeatability	45
4.8.8 Character Generation	46
4.8.9 Data Handling	46
4.8.10 Phosphor Burn Protection Circuit	48
5. CONCLUSIONS	49
6. PROGRAM FOR NEXT QUARTER	50
7. IDENTIFICATION OF PERSONNEL	50
8. DISTRIBUTION LIST	52

LIST OF ILLUSTRATIONS

Figure		Page
1	Photochromic Materials Tester	3
2	Modular Writing-Arm Expansion Technique	12
3	Absorption Characteristics	14
4	Typical Photochromic Real-Time Display	15
5	Elements of Photochromic Tester	18
6	Photochromic Tester Optical Schematic	19
7	Decay of Several Photochromic Compounds at 80°F	20

LIST OF ILLUSTRATIONS (CONT)

Figure		Page
8	Decay of Several Photochromic Compounds under 4000 foot-candle Illumination at 80°F	21
9	Decay of P158 Persistence under 2000 foot-candles at Three Temperatures	21
10	Decay of P102 Persistence under 2000 foot-candles Illumination at Three Temperatures	22
11	Decay of S50A Persistence under Three Illumination Levels at 80°F	22
12	Decay of P152 Persistence under Four Illumination Levels at 80°F	23
13	X-Y Mechanism	25
14	Analog Servo System	25
15	Digital Servo System	26
16	Cursor Mechanism	27
17	Photochromic Plate Changer	28
18	Packaging Arrangement	29
19	U. S. Navy Display System	30
20	Wedge System Optical Schematic	31
21	Coordinate Definition	32
22	Wedge Refraction Properties	33
23	Off-Axis Writing Method	37
24	On-Axis Writing Method	37
25	Four Writing Arm System	38
26	CRT Fiber-Optic Display System	39
27	Character Specifications	42
28	Yoke Deflection Amplifier	45
29	System Block Diagram (Using Charactron)	47
30	Phosphor Protection Circuit	49

LIST OF TABLES

Table		Page
1	COMPARISON OF DISPLAY PARAMETERS	10
2	TYPICAL MATERIAL PERSISTENCY CHARACTERISTICS . . .	19
3	CRT TEST CONDITIONS	41
4	PRELIMINARY SYSTEM CHARACTERISTICS	43
5	SUMMARY OF ESTIMATED AMPLIFIER ERRORS	45

1. PURPOSE

The purpose of this program performed under Contract DA-36-039 SC-90855 is to conduct a research study and an experimental investigation to determine techniques, methods of application and design criteria for automatically converting digital data into display form including graphs, maps, and pictorial displays.

2. ABSTRACT

State-of-the-art in Photochromic Displays is discussed. Comparisons are made of Army Artillery and Army Intelligence display parameters. Two possible techniques of advancing the state-of-the-art of the photochromic display technology are described: one electromechanical; and one electronic, employing a CRT for writing on photochromics.

3. REPORTS AND CONFERENCES

- a. Monthly Report of 1 December 1962 to 31 December 1962 by H. L. Bjelland.
- b. Monthly Report of 1 January 1963 to 31 January 1963 by H. L. Bjelland.
- c. Conference on 12 December 1962 at Fort Huachuca, Arizona. Attending were individuals representing U. S. Army, Ramo Wooldridge, and NCR Electronics Division.

Mr. H. L. Bjelland	NCR Electronics Division
Major Gilbert	Project Officer, Ft. Holabird
	Intelligence Combat Development Agency
Mr. Erich F. Kral	Project Engineer, Fort Monmouth
Lt. Laeser	Intelligence Design Team, Ft. Huachuca
Mr. J. T. Lynch	NCR Electronics Division
Mr. H. Simon	Ramo-Wooldridge
Mr. W. V. Taylor	NCR Electronics Division

Future concepts for Intelligence displays were discussed. Parameters applicable to large-screen displays were enumerated. A list of these parameters is presented in this report under Paragraph 4. Factual Data.

- d. Conference on 13 December 1962 at Ft. Huachuca, Arizona. In attendance were the following individuals representing U. S. Army and NCR Electronics Division.

Mr. H. L. Bjelland	NCR Electronics Division
Lt. Clark	Fire Support Design Team, Ft. Huachuca
Capt. J. Coomer	User Liaison Officer, Ft. Sill
Major Downing	Ft. Huachuca
Col. Fuller	Ft. Sill
Mr. Erich F. Kral	Project Engineer, Ft. Monmouth
Major Leehey	Ft. Sill
Mr. J. T. Lynch	NCR Electronics Division
Mr. R. Schneider	ADP Department, Ft. Huachuca
Mr. W. V. Taylor	NCR Electronics Division

The purpose of this conference was to consult with U. S. Army personnel in accordance with Signal Corps Technical Requirement SCL-4350, dated 28 November 1961, Paragraph 3.5.1. Priorities for the directions of effort for large-screen displays to be used by the U. S. Army Artillery were discussed. The items reviewed are detailed in Paragraph 4.1.2 of this report.

- e. Conference on 14 and 17 December 1962 at NCR Hawthorne, California between Mr. Kral of Ft. Monmouth and Mr. H. L. Bjelland of NCR. The purpose of Mr. Kral's visit was to review the subject contract and to outline the program to be performed initially.
- f. Conference on 31 January 1963 between Mr. Henry Burkhard of Ft. Monmouth and Mr. H. L. Bjelland of NCR, held at NCR Electronics Division, Hawthorne, California. A review of the progress of the Data Display Study contract was made by Mr. Burkhard and information was provided by Mr. Bjelland concerning the split X-Y system and the CRT photochromic system.
- g. Conference on 27 February 1963 between Mr. D. Grafton of NCR Hawthorne and Mr. Will Hicks of Mosaic Fabrications Inc., at Southbridge, Massachusetts. Mosaic Fabrications supplies fiber optic faceplates for many leading CRT manufacturers. While at Mosaic Fabrications, Mr. Grafton discussed problems of projection through CRT fiber-optic faceplates. Discussions were held on fiber optic performance as such problems relate to the specific applications of this Study contract. Also discussed was the effect of phosphor coating upon the efficiency of this method.

4. FACTUAL DATA

4.1 DISCUSSION OF DISPLAY PARAMETERS. During the report period, several conferences were held between NCR and Army personnel for the purpose of defining priorities and direction for a Data Display System. The dates, persons in attendance, and general purpose of each conference are described in Paragraph 3, Reports and Conferences. Specific items discussed are presented in Paragraphs 4.1.1, 4.1.2, and 4.1.3. Because a similar display was to be used by both the Intelligence and the Artillery agencies of the Army, the individual needs of each agency were recorded and comparisons made in an effort to determine the extent of common interest.

Information is presented in Paragraph 4.2 concerning research conducted by NCR in applying photochromic principles to Data Displays. Over 400 different photochromic dyes have been developed by NCR. Also provided is a description of a Photochromic Materials Tester (Figure 1) and results of experiments conducted with this unit on selected photochromic materials.

Two display systems that have been investigated in relation to the Data Display contract are the rotating-wedge display, and a CRT fiber optic display. These systems are described in Paragraphs 4.7 and 4.8.

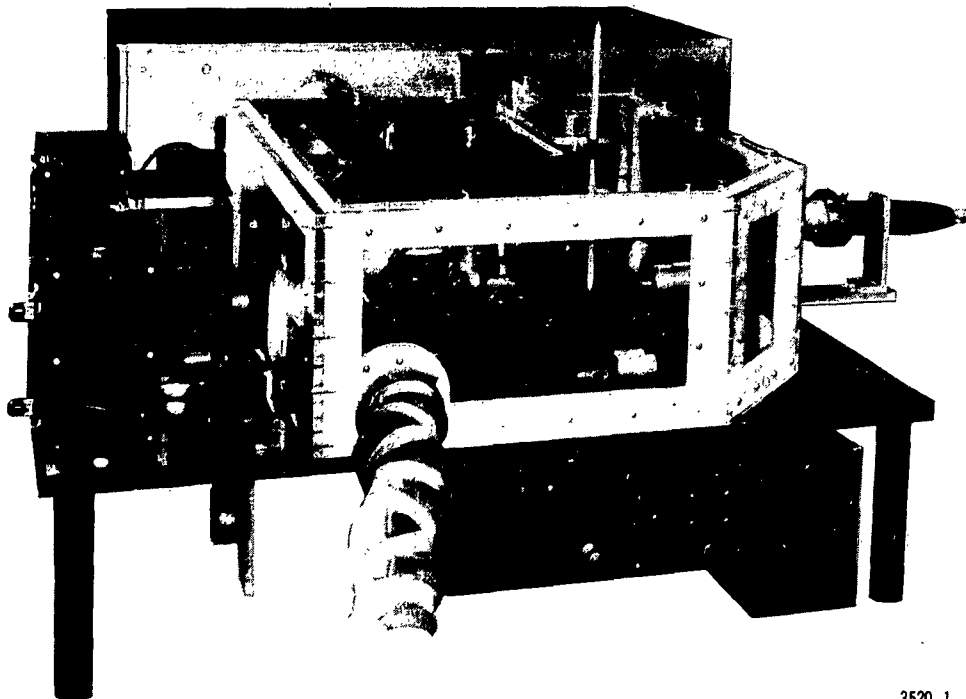

3520-1

Figure 1. Photochromic Materials Tester

4.1.1 Intelligence Display. The parameters for a large-screen Intelligence display are listed in the following text. These items were formulated in discussions with Army Intelligence representatives.

a. Backgrounds

1. Background maps would be photographed on 70 mm film.
2. A typical division level map is 45 by 65 kilometers.
3. Typically, 50 different background maps will be employed at the division echelon

b. Symbols

1. The number of basic alphanumeric and graphic symbols that would satisfy present and future requirements is 100 to 125.
2. Basic unit symbol size would be 1-1/4 inch wide by 3/4 inch high.
3. Symbol line width would be 1/32 inch.
4. Letter and number sizes would be approximately 7/32 inch.
5. A typical symbol group consists of an average of 15 symbols, including alphanumerics.
6. The center position for all symbols and alphanumerics will be supplied by a computer program supplying the input address, X and Y.
7. Symbol combinations will be programmed by the computer in a sequential mode.

c. Screen Characteristics

1. Screen size would be 5 ft by 7 ft.

2. Viewing angle would be 45 degrees, with respect to perpendicular to the screen center.
3. Anticipated group viewing distance is 10 ft to 12 ft.
4. Screen surface should permit grease pencil notations.
5. Data would be projected on the screen from the rear.

d. Environmental and Physical Considerations

1. Screen would normally be used in a van.
2. Ambient light level would range from moderate to that of a well-lighted room.
3. A degree of portability is desired, so that display can be easily disassembled into subassemblies of less than 125 pounds, and be reassembled at a different location.

e. Real-Time Track Writing

1. Writing should be possible while viewing display.
2. A persistence of 4 to 8 hours is desirable.
3. Accuracy within a given plane should be within 0.1 percent of full scale.
4. Relative accuracy should be within 0.1 per cent of full scale (overlay with respect to background map).
5. Resolution should be greater than 1000 by 1000 lines.

6. Display should be capable of drawing vectors, boundary lines, dotted lines, and circles, with a minimum of computer data.

f. Erasure and Updating

1. Selective erasure while viewing is desired.
2. Should be capable of erasing all dynamic data and rewrite up to 250 symbol groupings in less than 2 minutes.

$$\frac{250 \text{ Symb Gp} \times \frac{15 \text{ Symb}}{\text{Gp}} (\text{Avg})}{120 \text{ Sec}} \approx \frac{30 \text{ Symb}}{\text{Sec}}$$

g. Permanent Records

1. Permanent transparent records should be available on command for viewing.
2. Normal operation would permit data to accumulate for 4 to 8 hours. Then hard copy would be made of display data, all dynamic data erased, and a new display generated.

h. Special Features

1. For manual data entry during off-line, or training operations, a paper tape would be punched by a teletype device and inserted into the display system.
2. Colors might be used to distinguish categories. Red, yellow, green, blue, black and white are used.
3. A cursor and a method of highlighting new data for approximately 30 seconds is desirable.
4. Discussion was also held on a console-type message display and a toteboard display for group viewing.

4.1.2 Artillery Display. In meetings with Army Artillery personnel, the technical parameters for a Display System were set forth. The cost of the system was discussed in relation to the level at which the display would be used. At present, the display is planned for use at the division level, and ultimately at the battalion level. The Artillery group indicates that fire planning can be accomplished at the division level. Specifics of the Artillery Display are listed in the following paragraphs.

- a. Backgrounds and Cursors
 - 1. Color is desired for background map projection.
 - 2. Use of a cursor would enable communication with the computer and external devices. Cursor could be manually driven by a joystick control.
 - 3. Provisions for making adjustments between map and dynamic data are desired. Use of a cursor for this purpose is indicated.
- b. Symbols
 - 1. Colored symbols are not necessary; symbology is acceptable.
 - 2. Standard military symbols are listed in Field Manual FM21-30.
 - 3. The ability to change the orientation of symbols is desirable. Artillery personnel at Ft. Sill stated that they would investigate to determine whether this feature is necessary.
- c. Screen Characteristics
 - 1. Typically, a 40 by 40-inch screen is desired.
 - 2. Screen sizes at higher Army echelons might be as large as 5 or 6 feet square.
- d. Environmental and Physical
 - 1. Display should operate in ambient

light ranging from moderate to that of a well-lighted room.

2. Portability of display should be provided by easy disassembly into smaller subassemblies.
3. Portable subassemblies should weigh well under 125 pounds each.

e. Real-Time Track Writing

1. Capability should be provided for writing dynamic tracks while viewing.
2. Accuracy should be $1/16$ inch from true position; a desirable accuracy is $1/32$ inch, and an ultimate accuracy is within $1/10$ meter.
3. The ability to write and erase triangulation lines is desirable.
4. A capability should be provided to draw circles, boundary lines, vectors, and symbols. Irregular lines such as used for boundaries, etc., are drawn by line segments; the computer supplies the beginning and end point for all line segments.
5. Gun ranges should be written by circle segments by addressing X_0 , Y_0 , radius and angle.

f. Erasure and Updating

1. Selective erasure of less than 1 second while viewing is desired.
2. When it is desired to change scale or to erase the entire display and plot new data, 3 minutes should be the maximum delay time permitted to

plot 30 symbol groupings, an average of 8 to 10 symbols per group.

g. Permanent Record

1. Capability for a permanent record should be provided on an optional basis.
2. Means should be provided to easily generate and produce a transparent overlay which can be distributed to other Army Units.
3. Overlay should contain only dynamic data. Individual who uses overlay will place the overlay on a standard Army map to analyze data.
4. For the described purposes, the overlay should measure 40 by 40 inches, and be transparent.
5. Because of the resolution required, it is not necessary that the overlay reproduce the background map.

h. Special Requirements

1. It is desirable to highlight new data until operator takes action.

4.1.3 Comparison of Displays. A comparison of the similarities in the Display for the Army Intelligence and Artillery indicates that the same basic display technology can be used for both applications. It is extremely desirable not only to employ the same basic technology for both displays, but to use nearly identical display equipments, if possible. By developing a single display suitable to both agencies, logistic problems are simplified, training is reduced, less expensive systems result, and in an emergency, one system could substitute for another.

To simplify a correlation of the characteristics of the two displays, the major parameters are compared in Table 1. As shown in the table, accuracy, resolution, portability, and data input modes are essentially the same. Differing parameters are discussed in the paragraphs following the table. As will be explained, if a satisfactory method can be devised to substitute for the colored dynamic data plots, the functional considerations

of the Intelligence and Artillery displays are nearly identical, and could be fulfilled with the same type of projection display system.

TABLE 1. COMPARISON OF DISPLAY PARAMETERS

CHARACTERISTIC	INTELLIGENCE	ARTILLERY
Screen Size	5 by 7 ft	40 by 40 inches to 6 by 6 ft
Basic Symbol Capability	100 to 125	*125 or greater
Background Map	In color	In color
Boundary Lines	Yes	Yes
Circles	Yes	Yes
Symbols per Group	15 typical	8 to 10 typical
Unit Symbol Size	1-1/4 by 3/4 inch	3/8 inch
Line Width	1/32 inch	1/32 inch
Alphanumeric Symbol Size	7/32 inch	3/16 inch
Real-Time Writing While Viewing	Yes	Yes
Selective Erasure	Yes	Yes
Max. Symbol Speed	30/sec	2 to 5 seconds
Permanent Record	Photographic	Full Size Overlay
Screen Projection	Rear	Rear or Front
Persistence	4 to 8 hours	*1 hour minimum
Accuracy	$\pm 0.1\%$	1/16 inch out of 40 inches ($\pm 0.15\%$)
Resolution	1000 by 1000 lines	*1000 by 1000 lines
Portability	Yes	Yes
Manual Data Entry	Paper Tape	Cursor
Color Data Plot	Red, Yellow, Green Blue, Black, White	Not Required

TABLE 1. (CONT)

CHARACTERISTIC	INTELLIGENCE	ARTILLERY
Cursor	Desirable	Necessary
Highlight New Data	Desirable	Desirable

*Not specified by user but estimated by NCR

a. Screen

The Artillery and Intelligence displays are based on different screen sizes. A projection system is capable of adjustment to varying screen sizes merely by changing the throw distance. Or, if desired, the illumination can be reduced, permitting a more suitable throw distance through changes in the projection lamp and lens. Either a front or rear projection screen can be used with a projection system.

b. Symbol Capacity

As shown in Table 1, the symbol capacity is different for the two systems. By developing a symbol generator which has an easy growth potential, the maximum desired symbol capacity can be obtained simply by adding units to the symbol generator. A projection system can also accommodate a wide variety of symbol sizes.

It is suggested that symbol sizes be expressed as a percentage of screen size. The symbol sizes listed in Table 1 range from 1 to 1.5 percent of screen size.

c. Maximum Symbol Speed

The Intelligence display indicates a speed of at least six times that used in the Artillery display. As with the symbol capacity, the symbol speed can be accommodated for both systems through the development of modular expandability in the hardware. For example, one writing module can plot five

targets per second for the Artillery display. The addition of five writing modules to the Intelligence Display would then provide the increased symbol speed. See Figure 2.

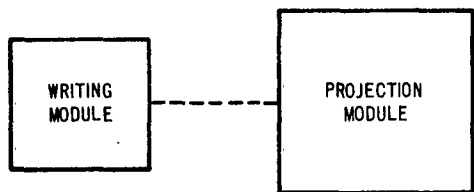

A. TYPICAL FIVE TARGET-PER-SECOND SYSTEM

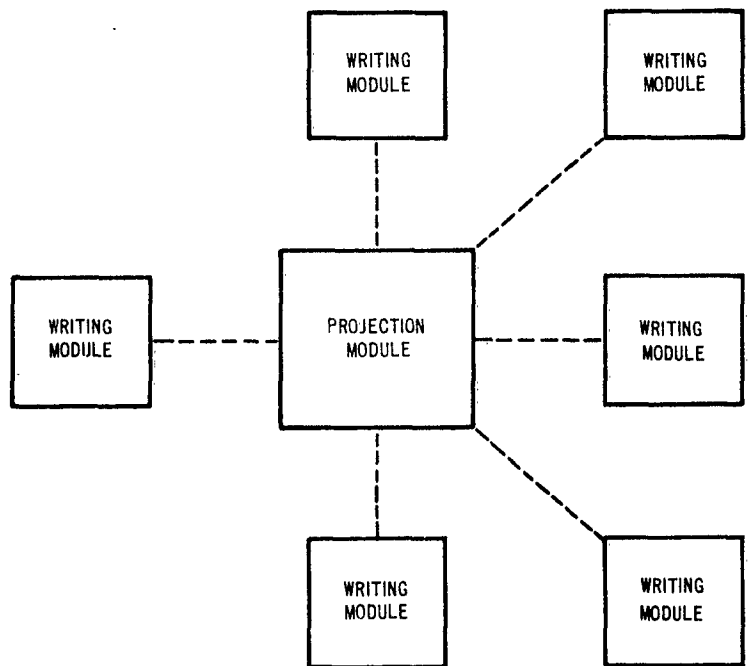

B. TYPICAL THIRTY TARGET-PER-SECOND SYSTEM

3520-2

Figure 2. Modular Writing-Arm Expansion Technique

- d. **Permanent Record Capability** A beam splitter in the projection path can provide the desired photographic record, whereas, a screen overlay can provide the full size record. Either, or both, type of record can be provided in the same device.
- e. **Persistence** Persistence, or memory time, requirements can be met by the same system. The system must be designed to accommodate the longest persistence and the capability must be provided to erase the display at will.
- f. **Color Symbology** In the parameters for the Intelligence display, color symbology is specified. The alternatives for standardization of display capabilities in this instance are: 1) provide a color capability for the Artillery display; or 2) devise a useful method which can be used instead of color for the Intelligence display requirements.
- The equipment required for color is generally three times the complexity as that required for black and white. Therefore, based on increased cost, decreased reliability, and increased complexity, it is preferable not to provide a dynamic color plotting capability. Instead of color the suggestion is made that consideration be given to special symbology to differentiate the desired categories, e. g. , double lines, dotted lines, or simply a meaningful symbol such as F or U superimposed on the target to distinguish between friendly or unfriendly.

4.2 **PHOTOCHROMIC PROPERTIES.** Photochromic technology is based on the reversible, light-sensitive properties of photochromic dyes. Upon application of light beams of the proper spectral distribution, these dyes are made to change from the transparent, to the colored state, and conversely. The normal state of the photochromic

dye is transparent to visible light. See Figure 3. Application of ultraviolet light to the dye causes the exposed portions to become darkened, thus absorbing visible light. The degree of visible light absorption is proportional to the integrated watt-seconds of ultraviolet exposure. To obtain an optical density of 1 (90 percent absorption of visible light), the photochromic dye must absorb approximately $1/3$ watt-second per square centimeter.

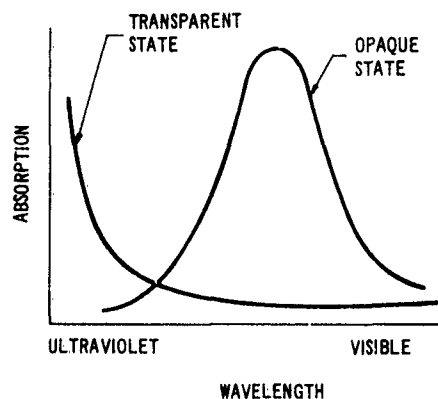

4495-1

Figure 3. Absorption Characteristics

Reversal of the dye to the non-absorptive (transparent) state is produced by applying visible light or heat, depending on the type of dye used. By controlling the incident illumination and temperature, a range of memory times, or persistencies, of the photochromic material is available.

The photochromic display is a projection-type display utilizing photochromic, or light-sensitive dyes as the memory medium. Information is written on photochromics with controlled ultraviolet light beams, while under projection. Information written on the memory medium is retained until erased by the natural decay time of the photochromic dye, or erased on command. Also, portions of the display, such as symbols and lines, may be selectively erased. Because photochromics is a reusable memory medium, the display can be generated repeatedly.

4.3 PHOTOCROMIC DISPLAY CONFIGURATIONS. One application of photochromic dyes is the real-time display system, such as illustrated in Figure 4. This display combines the advantages of a projection technique with the unique capabilities of NCR photochromic dyes. Writing of real-time tracks and alphanumeric characters is accomplished

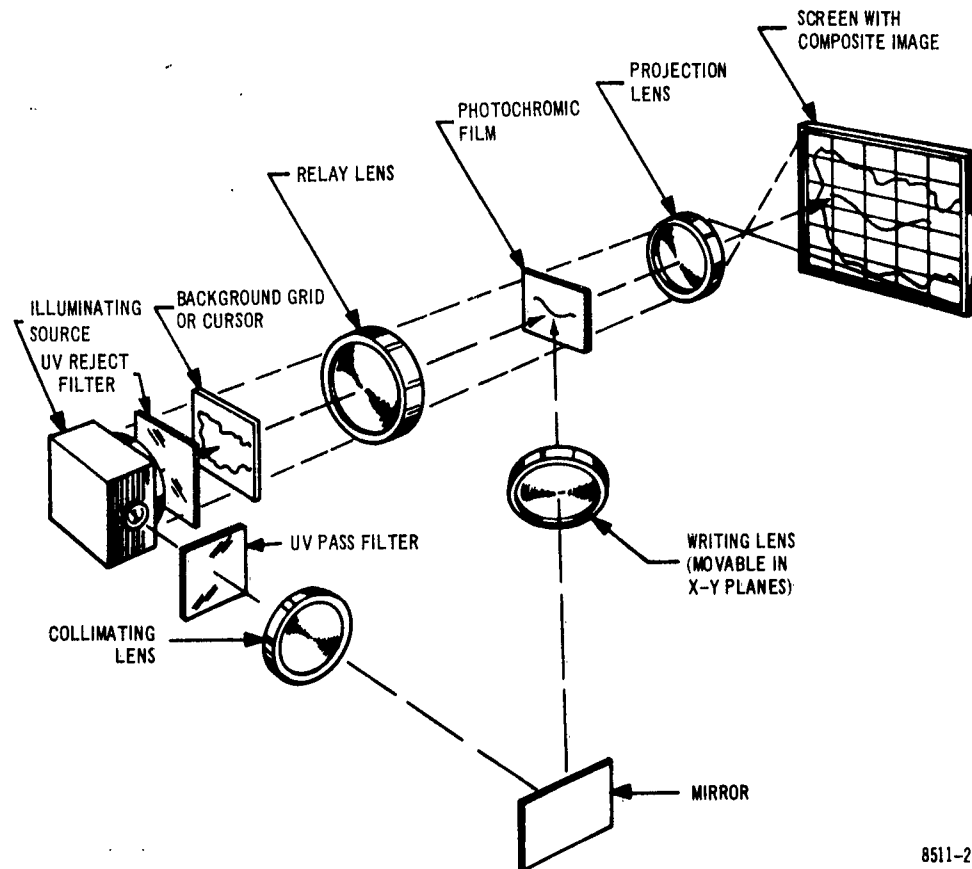

8511-2

Figure 4. Typical Photochromic Real-Time Display

with multiple light beams writing in reduced form on one common surface. The normally transparent photochromic film is placed in the primary optical arm of a projection system. Ultraviolet light, directed upon the photochromic surface, causes the material to switch to the colored state. Thus the data is projected to the screen as dark data against a light background, the same visual relationship to which we are accustomed in ordinary reading matter.

4.3.1 Composite Projection Channel. A single light source provides the energy for plotting data (UV) and projection (visible light). The background grids or cursors, and the dynamic information written on the photochromic plates are projected in series onto the screen. An ultraviolet reject filter prevents unwanted ultraviolet in the projection beam from reaching the photochromic plates. The projection light is collected by the

condenser lens and illuminates the background grid or cursor. This information is transferred and superimposed on the photochromic data by relay lenses. The projection lens transfers all the information to the screen.

4.3.2 Writing Method. The ultraviolet light may be formed in the shape of a symbol or character, or in the shape of a spot for writing tracks. Since plotting is accomplished by light beams, a number of tracks, symbols, or characters may be plotted simultaneously on the same photochromic plate. An X-Y servomechanism and writing lens combination positions the data on the screen. Input signals to activate these mechanisms may originate from a variety of sources, e.g., sonar, radar, computers, keyboards, manual writing boards. These signals supplied to X-Y writing arms, may be in the form of analog voltages or digital codes.

A coded track (dots, dashes, etc.) may be written by shuttering the writing beam, or each writing arm may be identified by a unique symbol imaged by a fixed mask placed in the writing light path.

In track writing, the highly concentrated ultraviolet light source is imaged on the photochromic plate after being reflected by a fixed mirror and passing through a collimating lens and writing lens. Areas of the photochromic film change to the colored state as a servo-controlled writing lens is positioned in X and Y axes by input signals.

Alphanumeric characters, or other symbols, may be written on the photochromic plate by simply masking the writing light beam to form the character. The character position on the photochromic plate is controlled by the writing arm servo movement in response to the X-Y input signals.

4.3.3 Persistence. The persistence or memory time, of the plotted information is a function of a number of parameters. First, various types of dyes have inherently different persistences. Over 400 materials are now in existence, with persistence ranging from a fraction of a second to an hour. For a given dye, the persistence time is affected by the ambient heat and light of projection impinging on the photochromic plate. The temperature of the photochromic plate may be varied by conventional means and can result in a persistence variation for a given dye of as much as 5 or 10 to 1. For the light-sensitive materials, the persistence can be varied by utilizing an off-axis light which varies the persistence without affecting the screen illumination. Permanent records are obtained by diverting a small amount of light to a camera by placing a beam splitter in the projection path.

4.3.4 Erasure. One of the unique properties of the photochromic material is that the material is reversible. Normally the photochromic slide is erased by the projection light after a period of time, and thus is made available for reuse. However, by applying

a high-intensity erasing beam to a selected area, selective erasure may be accomplished. The operation of the erasing channel is similar to the writing channel except that visible light instead of ultraviolet light is used. A visible light is imaged on the area to be erased. The colored state of the photochromic material absorbs this visible light and causes switching to the transparent state.

4.4 PHOTOCHROMIC MATERIALS TEST PROGRAM. Considerable data on photochromic materials has been developed by NCR Electronics Division on prior company-funded programs. Detailed characteristics on more than 400 dyes now in existence provide a flexible basis for display system study and development. These dyes can be broadly categorized according to the type of energy required to reverse the photochromic material from a colored to a transparent state: heat or light. This is only a general method of classifying photochromic dyes, since light reversible dyes are affected by heat to some degree, and vice versa. To determine the extent of the effects of temperature and incident illumination on the persistence of specific photochromic materials, a testing program was implemented by NCR. The nature of the test apparatus, and the results of specific tests are discussed in the following paragraphs.

4.4.1 Photochromic Materials Tester. A laboratory tester (see Figure 5) was devised by NCR for determining the effects of temperature and incident light on test samples. As shown in Figure 6, the tester consists of three optical channels, oriented about a rotatable aluminum disc.

- a. A Projection Channel projects an image of the test tracks onto a screen and permits changes to be made in incident illumination while the test track is under projection.
- b. A Writing Channel permits the writing of test tracks on photochromic samples at an off-axis angle of 45° .
- c. A Read-out Channel permits measurement of relative transmission of a test track by imaging the track onto a photomultiplier tube.

To perform persistency tests on a particular photochromic material, a sample of the material is coated on a 2- by 3-inch glass plate. The plate is installed in a window in the rotary disc and aligned with the projection and writing plane. When the desired incident illumination is obtained, a track is written on the sample by the writing lens. The disc is then rotated until the sample aligns with the Read-out Channel. A collimated light beam in the Read-out Channel illuminates the tracks. This image is focused through a microscope onto a narrow slit on a photomultiplier tube. The photomultiplier signal drives the vertical amplifier of an oscilloscope. The resulting trace is a curve representing the relative light transmission of the photochromic test track.

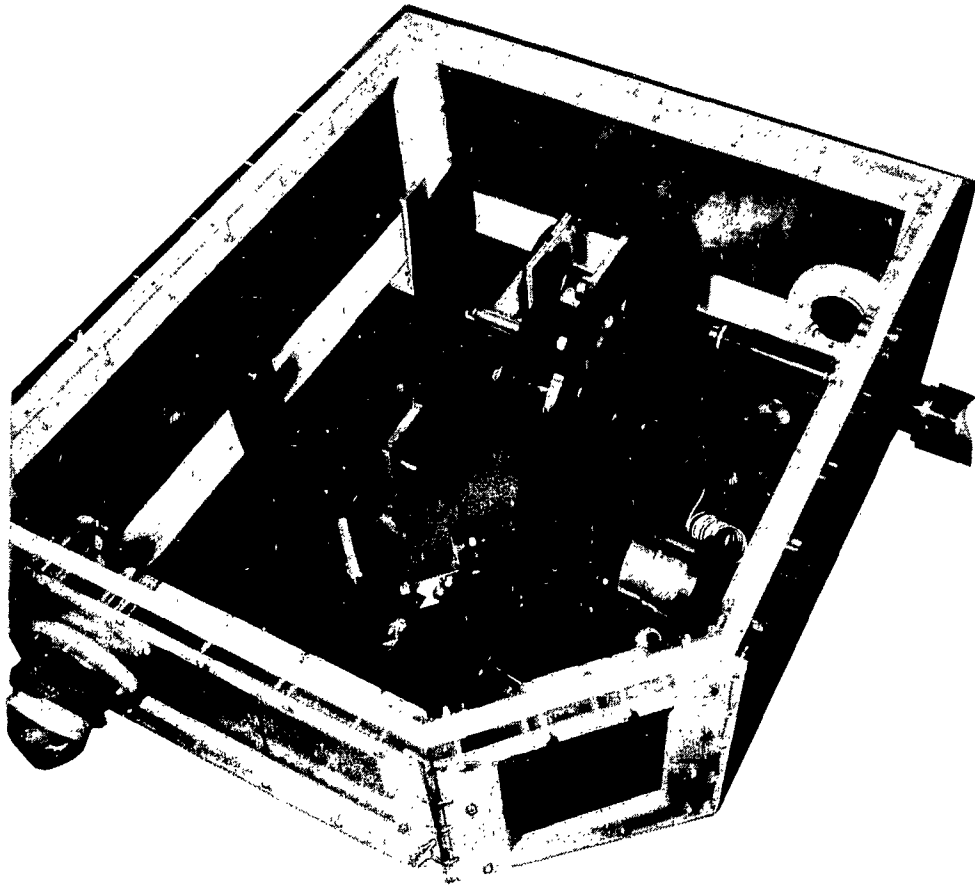
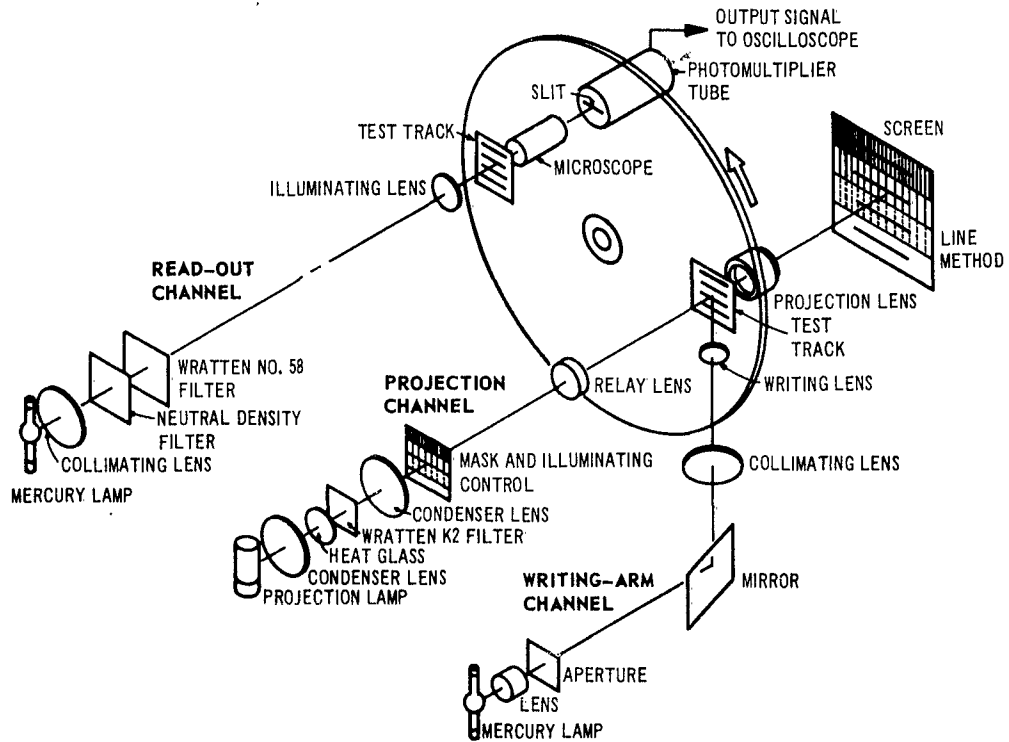

Figure 5. Elements of Photochromic Tester

Both temperature and incident illumination are essential factors in the testing of any photochromic material. Therefore the tester provides the facility for introducing controlled variations in these two areas. Temperature may be decreased to less than 45°F by means of the air conditioner in the tester. Variations in incident illumination are accomplished by substituting different values of neutral density filters in the projection channel.

4.4.2 Range of Persistency in Photochromic Materials. A brief summary of typical persistence characteristics determined through testing of numerous photochromic materials is presented in Table 2. Test curves for these materials are provided in Figures 7 and 8.



3520-3

Figure 6. Photochromic Tester Optical Schematic

TABLE 2. TYPICAL MATERIAL PERSISTENCY CHARACTERISTICS

MATERIAL	CHARACTERISTICS
S50A	Predominantly heat reversible; light produces considerable effect
P113	Predominantly light reversible; short persistence of 10 to 60 seconds
P102	Heat erasable; persistence relatively independent of illumination
P158	
P152	
D29	Predominantly light reversible

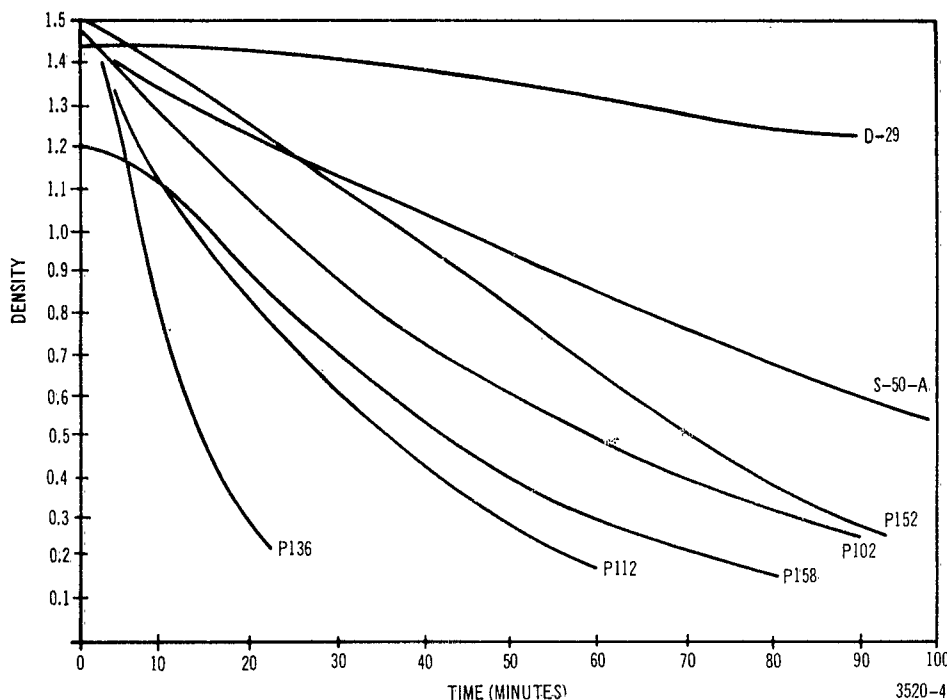

Figure 7. Decay of Several Photochromic Compounds at 80°F.

4.4.3 Temperature Tests. Effects of temperature on the persistency of selected photochromic materials have been established through an extensive testing procedure. Typical persistence curves for various materials as a function of temperature are shown in Figures 9 and 10. For display applications it will be necessary to retain a constant persistence regardless of ambient temperature variation. Therefore, a form of temperature control, such as the thermoelectric cooling chamber developed by NCR, will be necessary.

4.4.4 Incident Illumination Tests. To understand the significance of incident illumination on a photochromic material, consider a 20- by 20-inch screen, providing 15 foot-lamberts brightness. For a screen gain of 1.5, the required incident illumination is 10 foot-candles. A photochromic area of 1 by 1 inch is normally used. Neglecting lens losses, the illumination at the photochromic plate is

$$20 \times 20 \times 10 = 4000 \text{ foot-candles}$$

This illumination is typical of the data plotted in Figures 11 and 12. Thus, with temperature regulation of the photochromic material, a small 20- by 20-inch screen will provide a persistence of greater than 30 minutes.

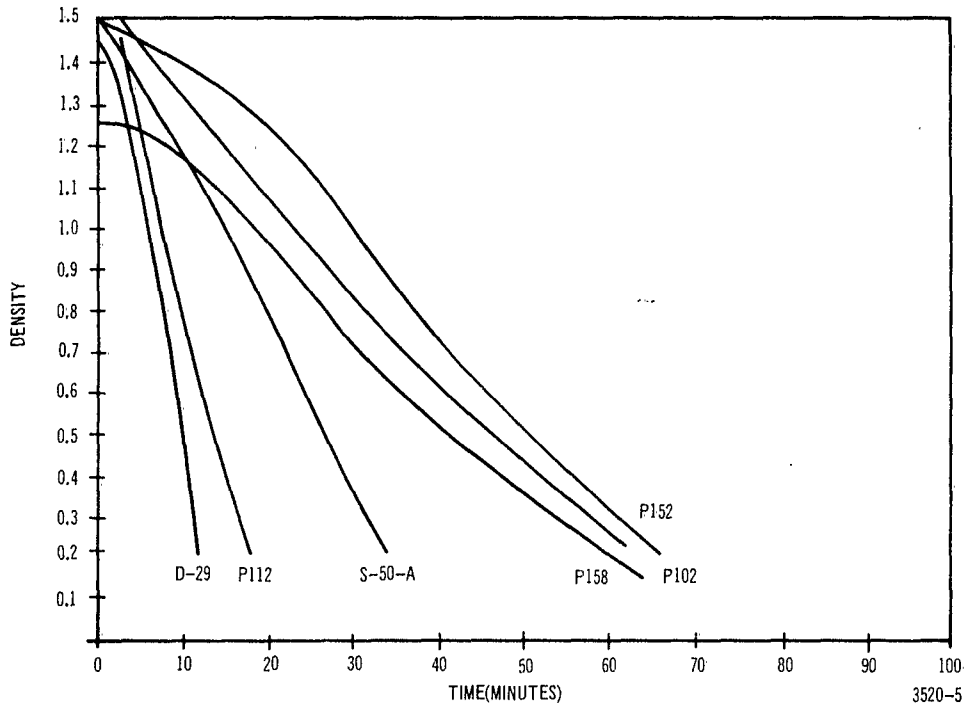

Figure 8. Decay of Several Photochromic Compounds under 4000 foot-candle illumination at 80°F.

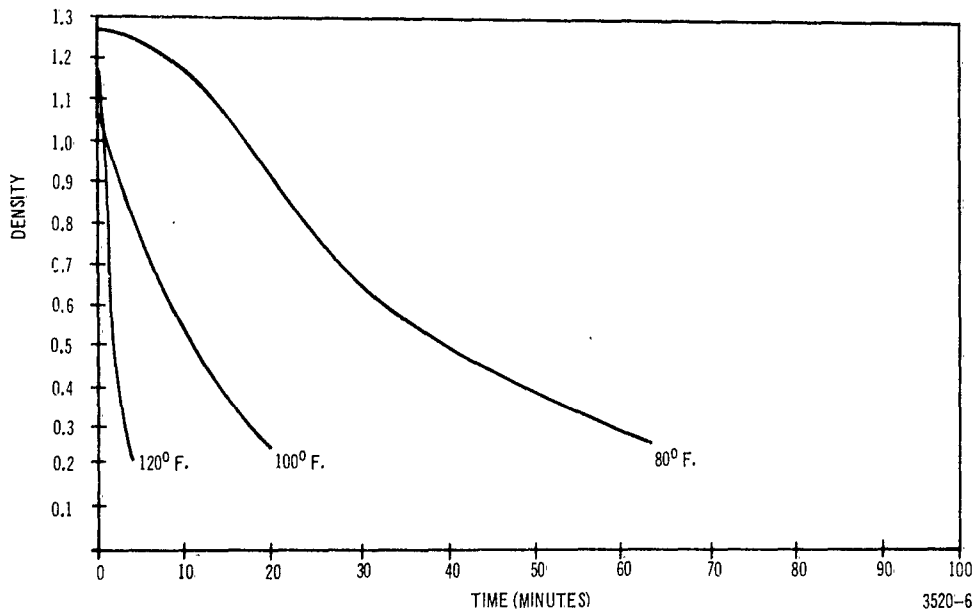

Figure 9. Decay of P158 Persistence under 2000 foot-candles at Three Temperatures

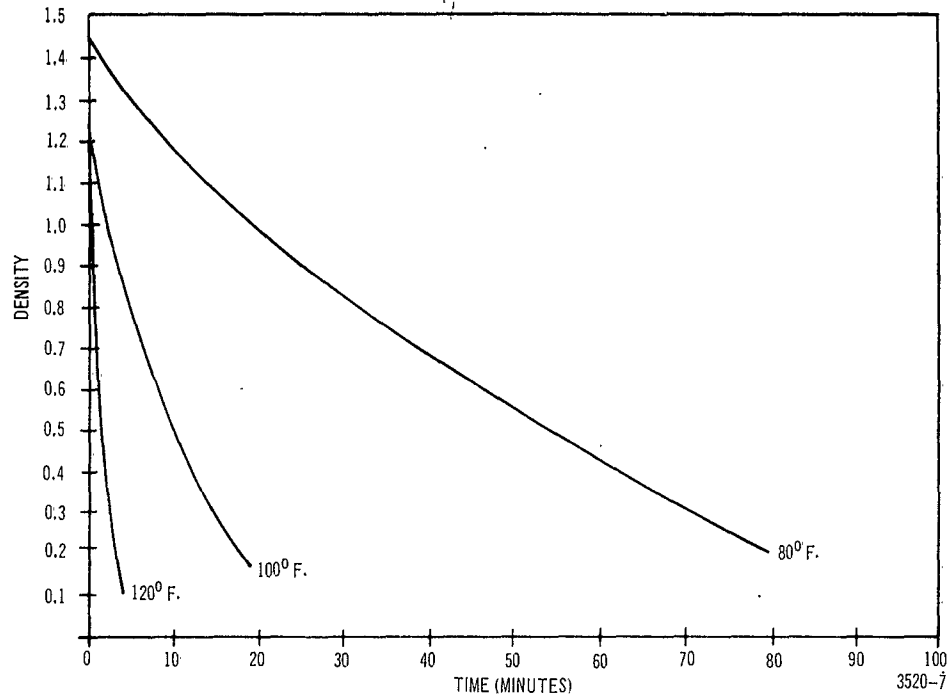

Figure 10. Decay of P102 Persistence under 2000 foot-candles illumination at Three Temperatures

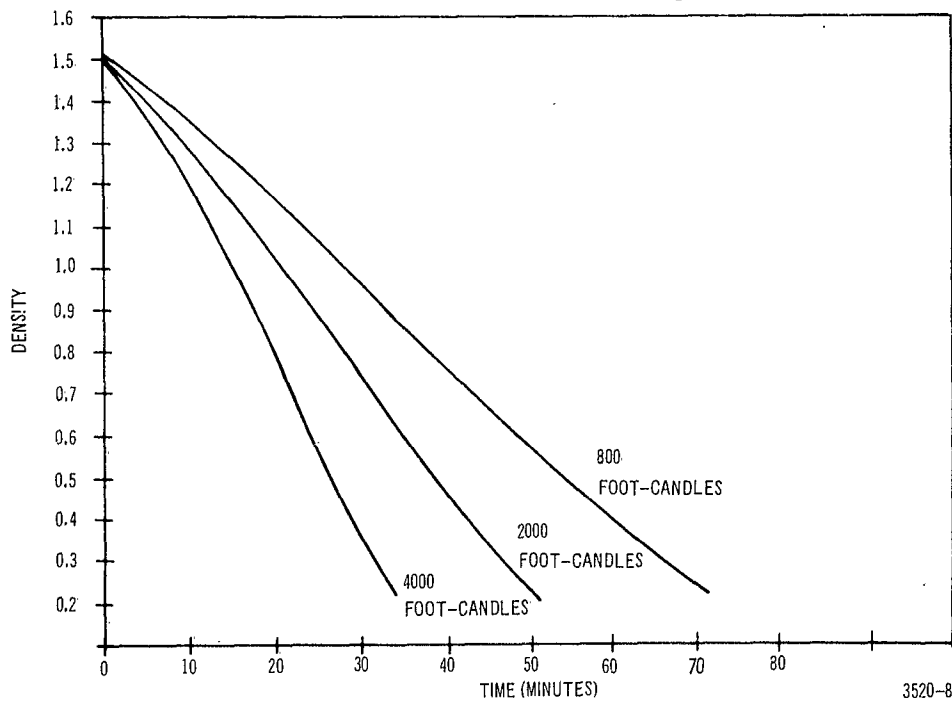

Figure 11. Decay of S50A Persistence under Three Illumination Levels at 80°F.

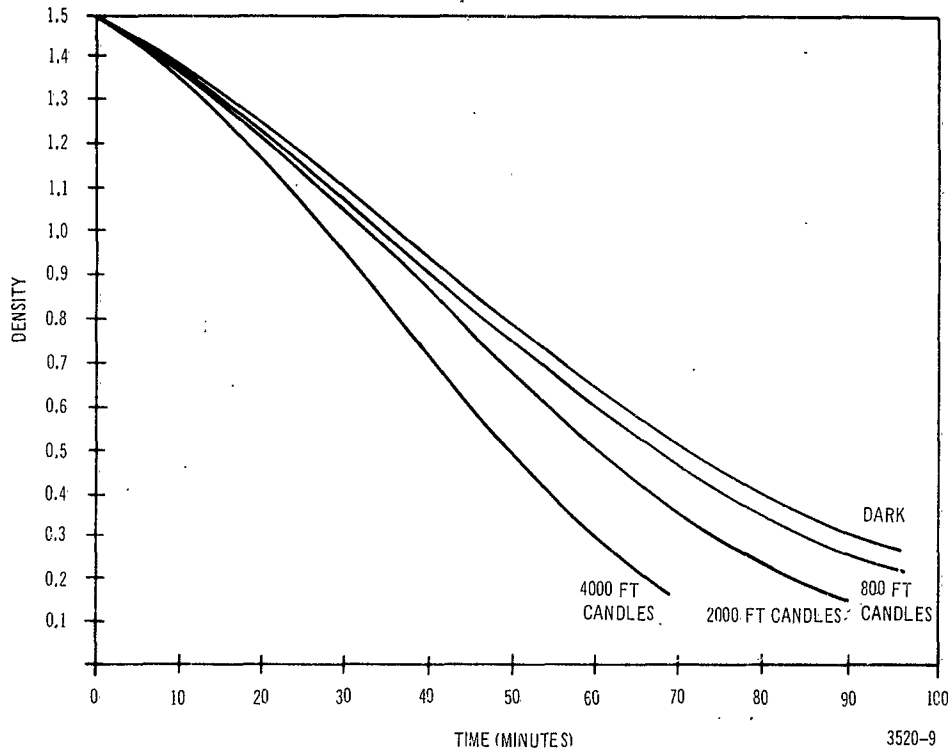

Figure 12. Decay of P152 Persistence under Four Illumination Levels at 80°F.

If the screen size in the preceding example were increased to 6 by 6 foot, and all other factors held constant, the incident illumination on the photochromic material would be increased more than 10 times, i. e.,

$$\frac{(6 \times 12)^2}{1} \times 10 = 51,840 \text{ foot-candles}$$

In recent tests conducted with the Photochromic Tester, an incident illumination of 50,000 foot-candles resulted in a persistence of about 10 minutes. Another series of tests were conducted at about 70°F with 25,000 foot-candles, resulting in a persistence of approximately 15 minutes. Additional tests are being conducted to determine the effects of various parameters such as coating effects, thickness effects, etc.

4.4.5 Photochromic Area Considerations. Enlargement of the area of the photochromic material produces an increase in persistence, since the incident illumination per unit area is decreased. Extension of the photochromic area much beyond 3 by 3 inches is impractical because of optical and mechanical problems. Therefore, using 3 by 3 as a maximum size for the photochromic plate, an incident illumination for a 6- by 6-foot screen would be

$$\frac{(6 \times 12)^2}{3 \times 3} \times 10 = 5760 \text{ foot-candles}$$

The effect of increasing the photochromic area from 1 square inch to 9 square inches is to reduce the incident illumination to a relatively low amount. In tests with P158 material at 80°F, with an illumination of 4000 foot-candles, a persistence of approximately 40 minutes was obtained. In addition, lowering the temperature of the photochromic material may provide a persistency in excess of 2 or 3 hours.

The testing reported in the preceding paragraphs has been made under specific conditions on the more commonly used materials. Recent testing has indicated that variation of physical characteristics will provide improved performance. Also, more exhaustive testing on a wider selection of available materials is expected to continue furnishing improved performance.

4.5 EXISTING DISPLAY EQUIPMENT. To provide a basis for discussion of state-of-the-art advances in data displays, the following background information is provided on existing equipment. This hardware, developed and fabricated by NCR, is presently being used by various Military agencies. An X-Y mechanism provides a dynamic writing capability, and a cursor mechanism permits the superimposition of real-time object positions. Additionally, a background map or other static data may be substituted for the cursor.

4.5.1 X-Y Mechanism. Shown in Figure 13 is the X-Y mechanism used to position the beam in X and Y axes. The servo system is a hybrid analog-digital system and the basic mechanism can be used for analog and digital inputs. The block diagram of the system used for analog inputs is shown in Figure 14.

Operation of this system is similar to a conventional analog system; a potentiometer is utilized to provide feedback information in a closed loop system. The main difference is that the mechanical driving device is an incremental stepper motor. The motor is utilized to position the servomechanism in a step or incremental fashion and to drive the system to an electrical null. This system has a number of advantages over a straight analog system. The firing threshold, that is, the error voltage that causes movement of the motor, is a function of the electronic circuitry and not a function of the stepper motor or varying load conditions. Thus, the system does not hunt, jitter, or oscillate because of slot effect, variation in friction torque, etc. In addition, the stepper motor produces a constant holding torque even though the error voltage is zero. Since the stepper motor moves in constant increments, the system repeatability is excellent. Because a portion of the system operates digitally, logic circuits may be used for control purposes, thus simplifying the circuitry in comparison to the analog counterpart. No damping tachometer is required. Some quadrature rejection is

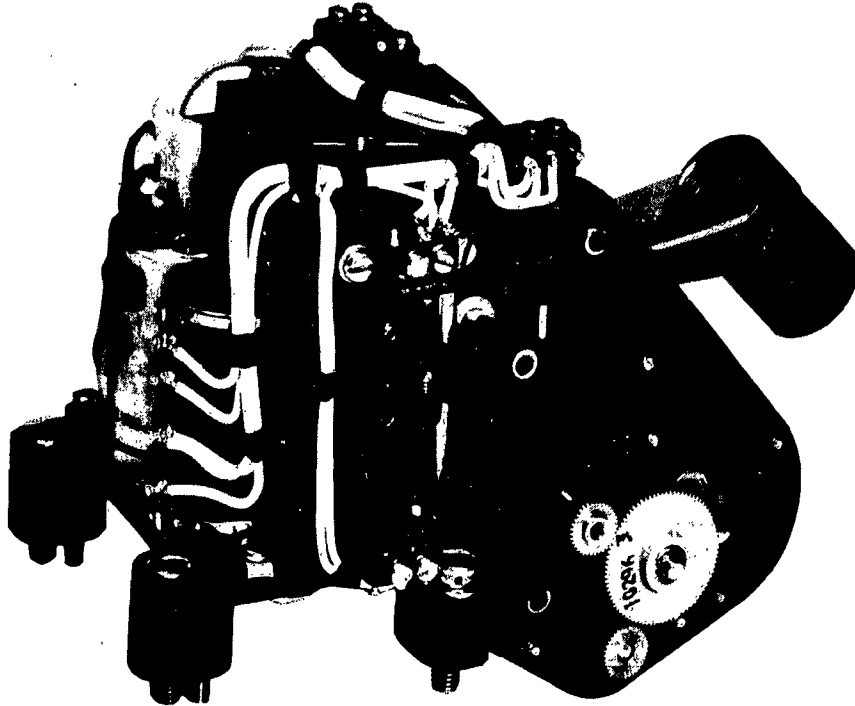

4495-3

Figure 13. X-Y Mechanism

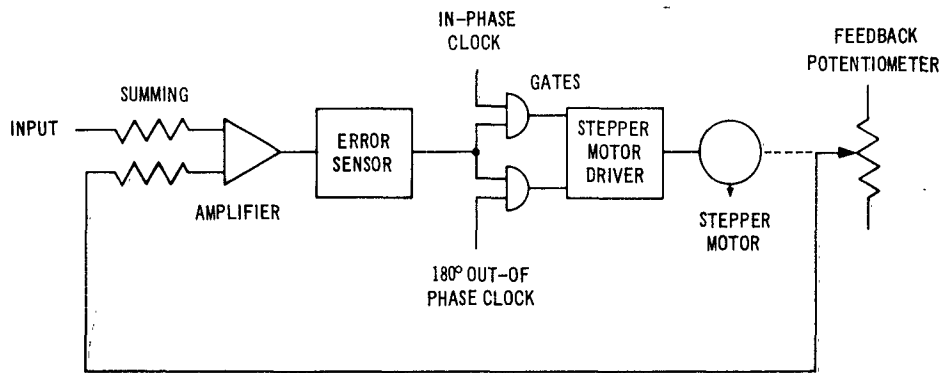

4495-4

Figure 14. Analog Servo System

inherent in the system. The gear ratio between the motor and the load is nearer unity; consequently, fewer gears are required.

When using digital inputs, the system is modified as shown in Figure 15. An input address register is used to command a new position. A feedback counter is used to monitor the stepper motor position. The comparator determines which direction the stepper motor must rotate to reach a null and drives the stepper motor in the appropriate direction. When the feedback counter address matches the input address message, a null is reached and the X-Y movement stops. Error check logic provides a 1 to 1 correspondence between the stepper motor drive pulses and the actual stepper motor position. If an error is detected, the system automatically returns to zero and resumes counting until a null is achieved.

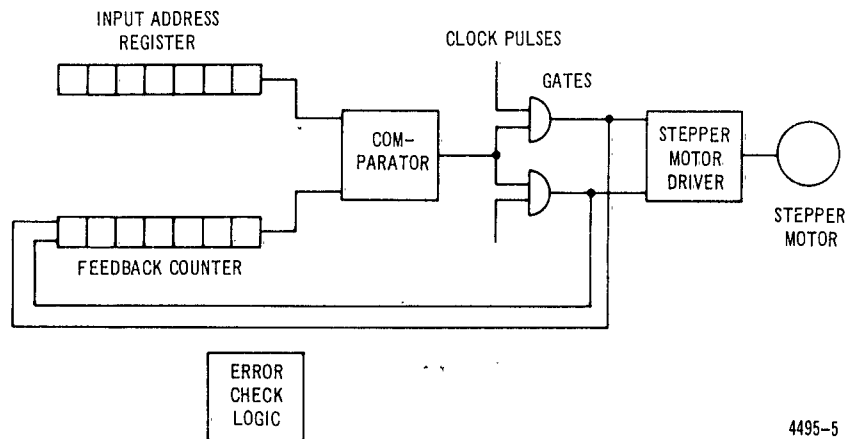
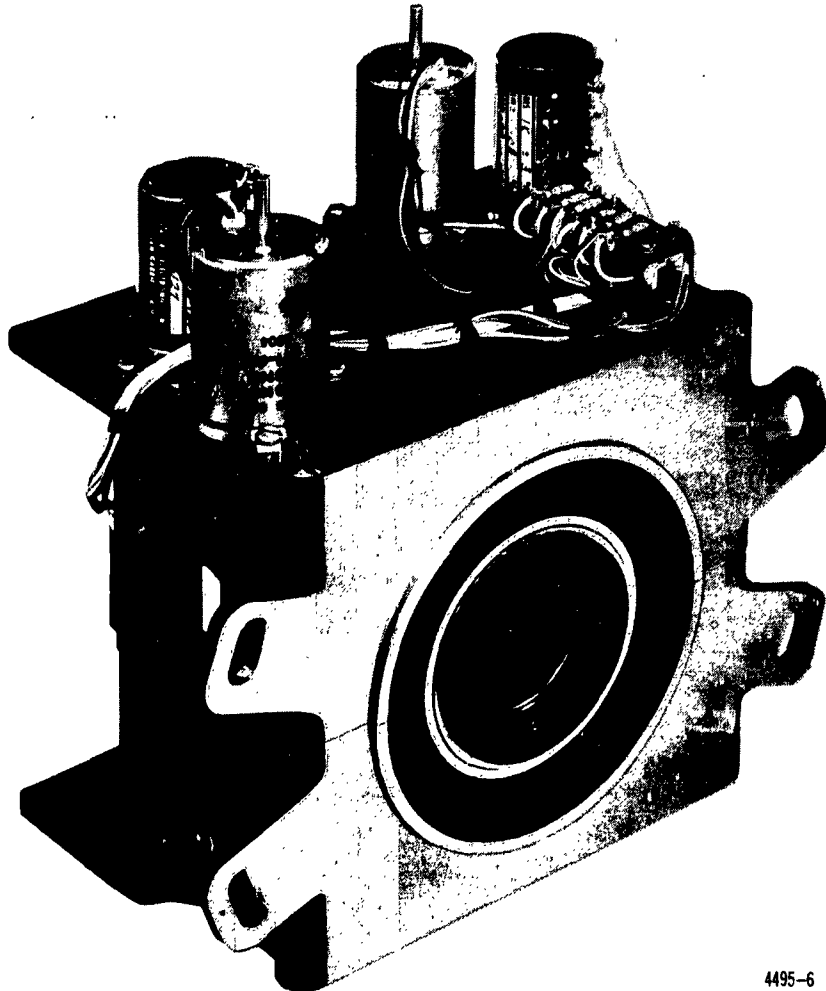

Figure 15. Digital Servo System

4.5.2 **Cursor Mechanism.** Real-time indication of a vector pointer, or circle locator is provided by the cursor mechanism (Figure 16). This mechanism can be positioned in X, Y or θ to locate any position on the screen. Driving electronics are similar to those used in the X-Y mechanism. The cursor is placed in the main optical arm in an image plane position, such as the background grid position.

4.5.3 **Photochromic Plate Changer.** When a change in plotting surface is desired, it is necessary to rapidly access a new photochromic surface. Conventional slide mechanism changers or rotary changers may be employed for this purpose. A rotary slide changer of the type shown in Figure 17 permits selection of any one of six photochromic surfaces. Because many photochromic materials have approximately the same sensitivity, it is practical to contain different types of photochromic material in a slide changer. The accurate registration mechanism allows rotation of the photochromic



4495-6

Figure 16. Cursor Mechanism

changer to fresh plotting surfaces when an electronic scale change is required. To return to the original scale, the changer is reversed and the system resumes plotting in the original scale. Typically, a new plotting surface can be provided in less than 2 seconds.

4.5.4 Packaging Design. A photochromic display for a typical application is shown in Figure 18. In this design, a symmetrical packaging arrangement is possible since the servos and optics can be mounted and referenced to the central optical axis. Thus, all components for the individual writing arms are interchangeable. Typical packaging



4495-7

Figure 17. Photochromic Plate Changer

- | | |
|-------------------------------|------------------------------|
| 1. LAMP | 11. X-Y SERVO (4 REQ'D) |
| 2. CONDENSER LENS | 12. P.C. PLATE |
| 3. CURSOR | 13. P.C. PLATE CHANGER |
| 4. RELAY LENS | 14. SOLENOID |
| 5. APERTURE LENS (4 REQ'D) | 15. P.C. PLATE CHANGER MOTOR |
| 6. SHUTTER (4 REQ'D) | 16. FIBRE OPTIC PLATE |
| 7. MIRROR (4 REQ'D) | 17. BEAM SPLITTER |
| 8. COLLIMATING LENS (4 REQ'D) | 18. PROJECTION LENS |
| 9. MIRROR (4 REQ'D) | 19. MIRROR |
| 10. WRITING LENS (4 REQ'D) | 20. CAMERA |

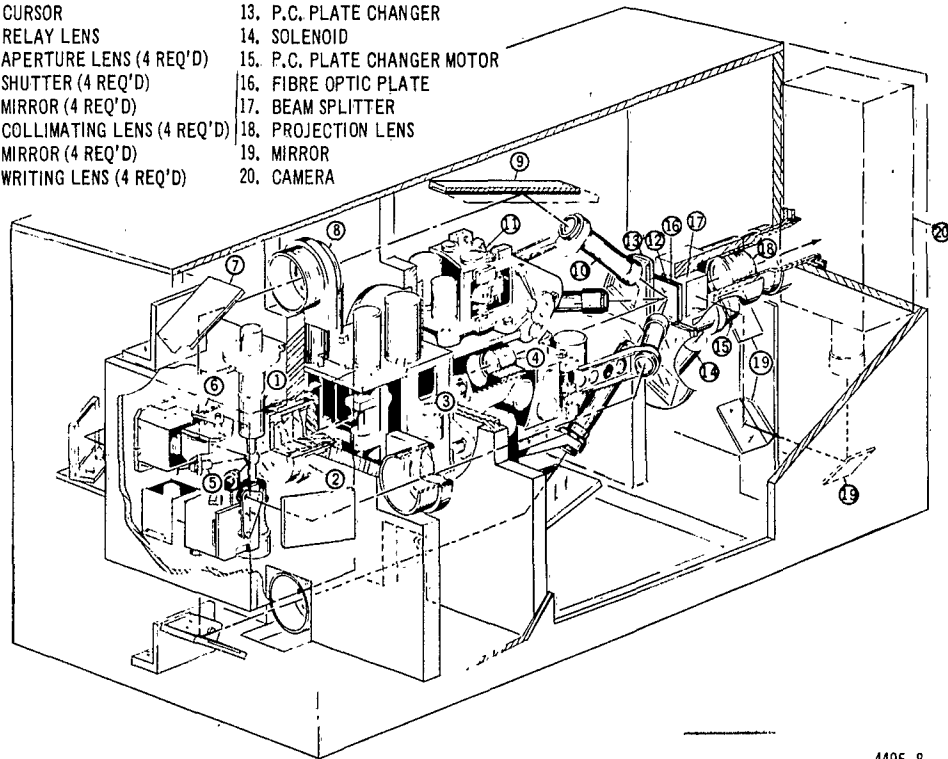

4495-8

Figure 18. Packaging Arrangement

densities are such that a display having the capability of four writing arms and a cursor, can be contained in a package of approximately 14 by 14 by 25 inches. This size is exclusive of the space required for the associated electronics and the optical throw to the screen.

4.5.5 U. S. Navy Display System. The Graphic Display shown in Figure 19 is a projection-type system developed by NCR for the U. S. Navy Bureau of Weapons to be used with other naval electronic equipment. This system is used to display several objects on a screen whose discrete X-Y positions are represented by analog voltages. The Graphic Display accepts signals derived from a data acquisition system and converts the information to a visual display. Three writing arms are contained in this unit, with easy growth capability to four arms. Other capabilities of the display are as follows:

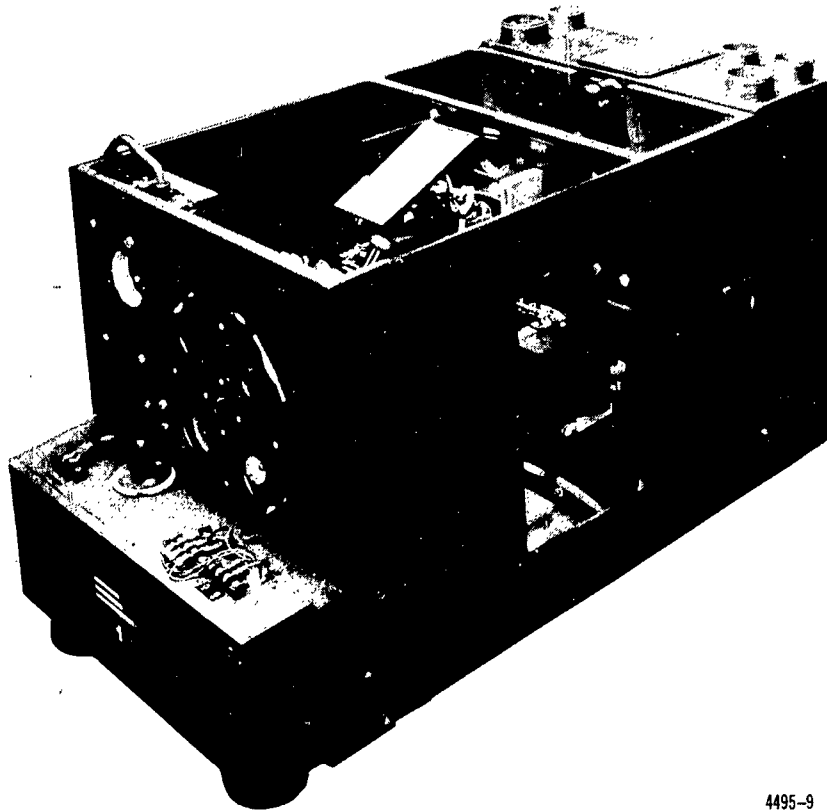

4495-9

Figure 19. U. S. Navy Display System

- a. Retention of track display for a period of greater than 10 minutes.
- b. Display of one non-permanent cursor or variable heading vector emanating from a center spot.
- c. Screen clearance on command within 2 seconds.
- d. Control of spot position and motion.
- e. Accuracy is greater than 0.5 percent and servo slew time is 2 seconds.
- f. The system is designed for use with a 20- by 20-inch screen.

4.6 STATE-OF-THE-ART DISPLAY ADVANCEMENTS. The primary advantage of the electromechanical system described in the preceding paragraphs is that working units have been developed and placed in use. Accuracy of the electromechanical system is better than generally provided by electronic displays. Disadvantages of the electromechanical system are related to reliability, maintainability, and plotting speed. Each

manufactured unit must be individually machined to precision tolerances, thus increasing cost and complicating alignment and servicing. Because of the electromechanical nature of this equipment, plotting speed is comparatively slow, e.g., typically only a few targets per second.

In initiating the Data Display Study, limitations of present systems were known, and advanced systems requirements were tentatively established. However, to provide an objective investigation of potential state-of-the-art advances, a different form of system implementation was necessary. A survey of several possible approaches led to the selection of two systems: 1) electromechanical rotating-wedge system and 2) a non-mechanical system using a CRT. Although it is recognized that the electromechanical approach has certain inherent limitations, it was believed that the rotating wedge concept offered sufficient advantages over existing displays to warrant further exploitation.

During the initial phases of the study program, both systems were considered to develop the relative advantages and disadvantages of each approach.

4.7 WEDGE SYSTEM. An optical schematic of the proposed wedge system is shown in Figure 20. The aperture lens images the ultraviolet light source on the aperture mask to shape the writing light into the shape of the required symbol. The collimating lens collimates the light output of the aperture mask to illuminate the rotating wedges. The X pair of counter rotating wedges deflects the ultraviolet beam in the X-coordinate. The Y pair of wedges is displaced 90° from the X pair and provides deflection in the Y-coordinate. The $\rho\theta$ wedges are used to draw circle, given a radius ρ or a straight line between two points given X_0, Y_0, X_1, Y_1 and θ . A definition of coordinates is presented in Figure 21.

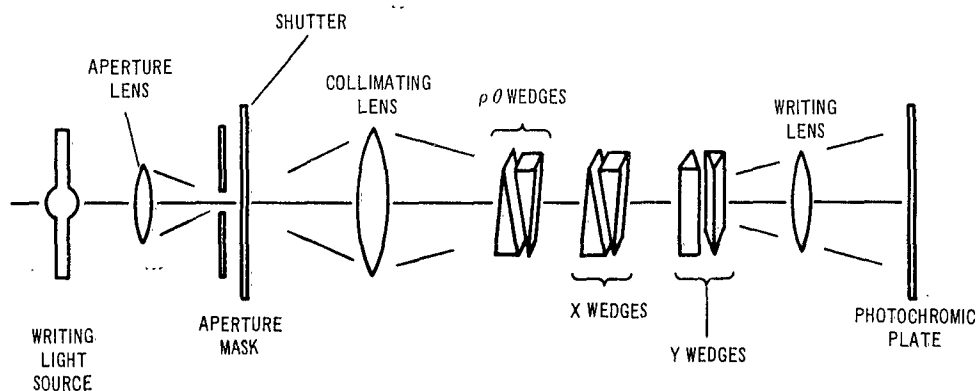

3520-10

Figure 20. Wedge System Optical Schematic

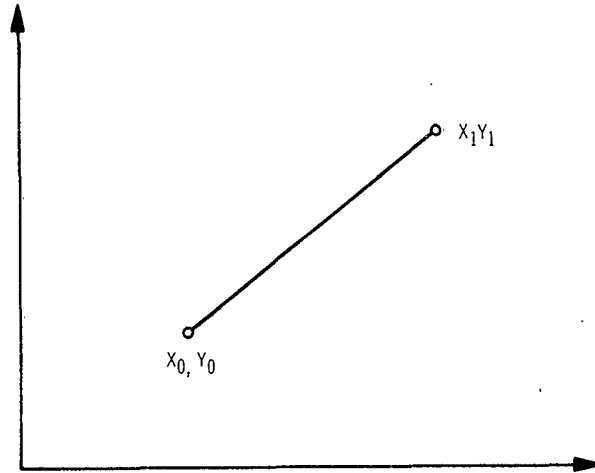

3520-11

Figure 21. Coordinate Definition

4.7.1 Theoretical Discussion of Wedge System. A theoretical discussion of the wedge system operation follows. A definition of wedge refraction properties is illustrated in Figure 22. For light entering a single prism, or wedge, application of Snell's law results in

$$\frac{n'}{n} = \frac{\sin 1/2 (\alpha + \delta)}{\sin 1/2 \alpha}$$

Where n, n' = indexes of refraction

α = refracting angle

δ = angle of deviation

When the refracting angle is small enough so that the sine of the angle equals the angle, and if $n = 1$ (air), then for a thin wedge in air

$$n' = \frac{\alpha + \delta}{\alpha}$$

$$\delta = (n' - 1) \alpha$$

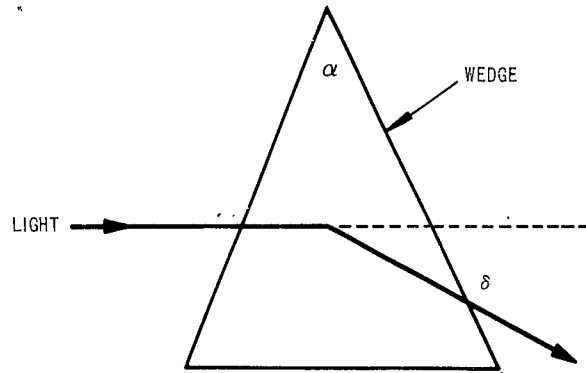

3520-12

Figure 22. Wedge Refraction Properties

Typically for an angle of 0.1 radian or 5.7 degrees, the difference between the angle and the sine of the angle is less than 0.2 percent.

For two wedges in series, the angle of deviation, δ_1 and δ_2 , adds vectorially as a function of the angle between the wedges. The resultant from the law of cosines is

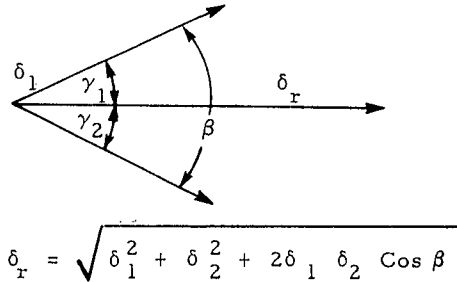

Now if $\delta_1 = \delta_2 = \delta$ and $\gamma_1 = \gamma_2 = \gamma$ and the X-axis is used as reference, then

$$\begin{aligned} \beta &= 2\gamma \text{ and } \delta_x = \sqrt{\delta^2 + \delta^2 + 2\delta^2 \cos 2\gamma} \\ &= \delta \sqrt{2} \sqrt{1 + \cos 2\gamma} \end{aligned}$$

since $\sqrt{1 + \cos 2\gamma} = \sqrt{2} \cos \frac{2\gamma}{2}$ or $\sqrt{2} \cos \gamma$, then

$$\delta_x = \delta \sqrt{2} \sqrt{2} \cos \gamma$$

$$\delta_x = 2\delta \cos \gamma \text{ for thin prisms}$$

Where δ_x = deflection in X coordinate

δ = angle of deviation

γ = Half angle between prisms

By varying prism δ_1 and prism δ_2 to $+\gamma$ and $-\gamma$ angle with respect to the resultant, the resultant will vary in magnitude from $+2\delta_1$ to 0, and to $-2\delta_1$. Thus, X-axis position is obtained as a function of the cosine of the wedge angles.

By inserting another pair of prisms in series with the first pair and rotating the resultant vector 90° , Y-deflection is obtained, and then

$$\delta_y = 2\delta_{y1} \cos \theta$$

Where θ = half angle between Y pair of wedges

The resultant of the X and Y pairs of wedges will also add vectorially

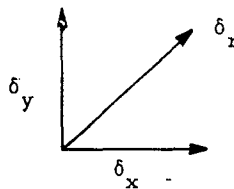

$$\begin{aligned} \delta_r &= \sqrt{\delta_x^2 + \delta_y^2} \\ &= \sqrt{4\delta_{x1}^2 \cos^2 \gamma + 4\delta_{y1}^2 \cos^2 \theta} \end{aligned}$$

If $\delta_{x1} = \delta_{y1} = \delta$

$$\delta = \delta \sqrt{\cos^2 \gamma + \cos^2 \theta}$$

Therefore, any X or Y position can be obtained by varying the angles γ and θ of the individual wedge pairs. Previously, it was determined that each set of wedges individually could cover any X or Y position and collectively any X-Y position.

If a third pair of wedges are inserted in series with the other two pair, additional possibilities are present. By rotating the reference axis of the third pair of wedges, a straight line can be generated by rotating the wedges at a constant velocity. Another alternative use of the third pair of wedges is for circle drawing. First, the third set of wedges are rotated, one with respect to the other, to establish a radius ρ

$$\rho = 2\delta_{\rho} \cos \theta$$

The two wedges should then be rotated together through 360° and the light will trace a circle of radius ρ .

The third set of wedges, operating in conjunction with the X and Y pairs, then provide the possibility of writing a circle of radius ρ which can be displaced to a X_0 - Y_0 location by the X and Y pair of wedges respectively. The X and Y pairs of wedges have the same effect in the line drawing mode since they will displace the origin of the line by X_0 - Y_0 .

4.7.2 System Advantages. By examining the equations and reviewing the system operation, a number of possible advantages for the widget system become apparent.

- a. In any X-Y mechanism which must combine two independent motions in one physical package, critical tolerances must be maintained in each individual plane, and also from one plane to the other. The result is a complicated and expensive mechanism. An advantage of the widget system is that through a physical displacement of the X and Y axes, the desired simplification and economy is obtained.
- b. The widget system is driven by a rotary motion which is the normal output of a servo system.
- c. Another possible advantage is that the writing speed may be increased over the presently existing system. Through use of a stationary writing lens, the diameter and speed may be increased over the present system.
- d. One of the most significant advantages of the system is the ability to draw circles and lines with a minimum of computer data. For example, to draw a circle, X_0 , Y_0 and ρ coordinates are fed into the computer. The circle is displaced to X_0 by the X pairs of wedges and displaced to Y_0 by the Y pair of wedges. Then the ρ coordinates are fed into the $\rho \theta$ wedges. First the $\rho \theta$ wedges are displaced with respect to each other by an angle proportional to ρ . The shutter is opened and the wedges are both rotated in the same direction for 360° ; the system will draw a circle of radius ρ with the origin at X_0 - Y_0 . A minimum of computer data is desirable to draw pairing lines, boundary lines, vectors, or in general straight lines between two points. Ideally, writing could be accomplished by two computer words, the first

containing the origin of the lines X_0 , Y_0 , and the second containing the end of the line X_1 , Y_1 . Thus, point-by-point plotting or analog methods for circle writing are not necessary. A circle can be plotted with a single 38-bit computer word, i. e., $10X$, 10ρ , $10Y$, and 8 control and miscellaneous bits.

- e. In the widget system, an identical mechanism can be used for all three wedge pairs, thus simplifying design, reducing cost, and enhancing logistic considerations.
- f. In addition, a rapid slew speed may be obtained, thereby increasing the random plotting speed capability.
- g. One very significant advantage is that the basic system would be very versatile. For small-screen applications, use of a 1 by 1-inch photochromic area may be desirable. For large-screen application, use of a 3 by 3-inch area may be desirable. Satisfactory use of the same basic servomechanism for 1-inch and 3-inch deflection requirements is anticipated merely by changing system constants, such as wedge angle, optics.

4.7.3 System Disadvantages. Unfortunately there are also disadvantages to the system.

- a. One disadvantage is that the deflection at the photochromic plate is a cosine, or nonlinear function. This deflection could possibly be made linear by one of several possible techniques, e. g., optical, mechanical or electrical compensation.
- b. Another disadvantage is that the system is so far only feasible for on-axis writing. This on-axis writing feasibility makes the problem of growth potential a difficult one. However, this problem must be further investigated to devise a method whereby the Widget system can be used for off-axis writing.

4.7.4 Off-Axis Writing Method. To further explain growth potential, a comparison must be made of the total speeds of on-axis versus off-axis writing. Consider, first, an off-axis writing system as illustrated in Figure 23. In off-axis writing, the writing light is directed at an off-axis angle to the projection axis, e. g., 45° . One of the advantages of this off-axis system is easy growth potential. Additional writing lenses may be added about the projection axis to meet the requirements of a slow or medium speed system. Typically, from 1 to 4 writing lenses can be used.

4.7.5 On-Axis Writing Method. For an on-axis system, the most feasible way of

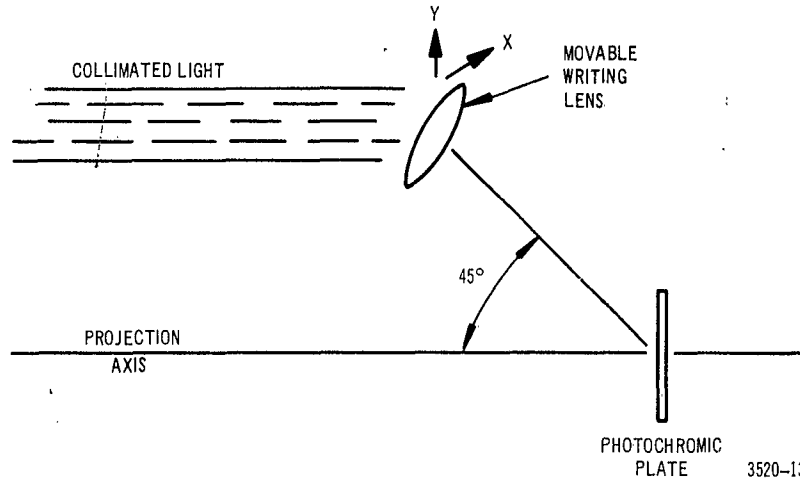

Figure 23. Off-Axis Writing Method

directing ultraviolet onto the photochromic material is to use a dichroic mirror as shown in Figure 24.

The dichroic mirror reflects ultraviolet and passes visible, providing an ideal method of combining two different wavelengths of light into one channel. Since only one writing beam may be on axis with the photochromic surface, additional writing arms if desired, must be optically combined before reaching this point. One suggested method is shown in Figure 25. Writing channels A and B are combined by mirror 1. Since the light output for both A and B is ultraviolet, mirror 1 must be of the type which reflects 50 percent and transmits 50 percent of the impinging energy. The operation is the same for mirror 2 and channels C and D. Mirror 3 combines $\frac{A + B}{2}$ and $\frac{C + D}{2}$ and

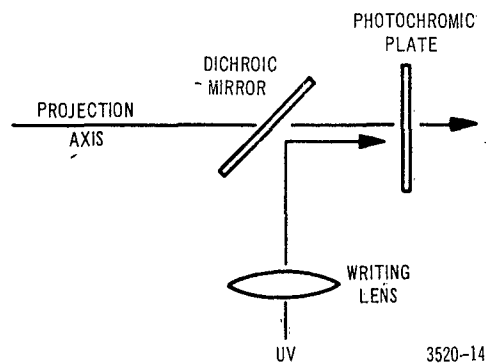
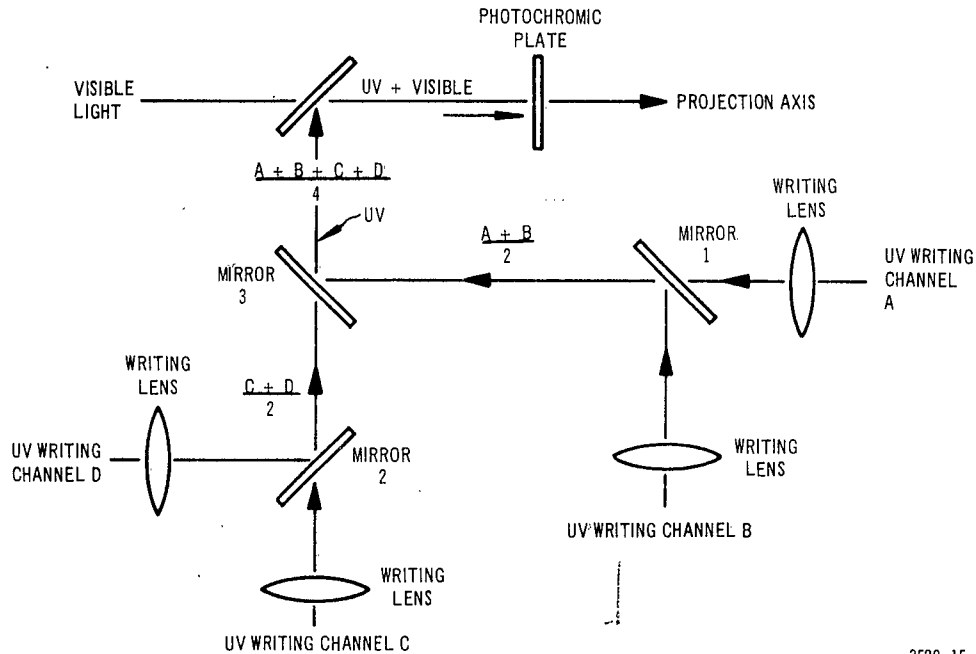

Figure 24. On-Axis Writing Method



3520-15

Figure 25. Four Writing Arm System

provides a theoretical light output of $\frac{A + B + C + D}{4}$. Therefore, the initial writing energy is reduced by a factor of 4.

4.7.6 Comparison of Writing Speed. To understand the significance of these factors, consider the operation of NCR's present display technology as an example. The full-scale slew speed for the servo system is 2 seconds, with about 20 milliseconds required to write a data point. Assuming random plotting, on the average the servo system would only have to travel half-scale. Therefore, the average servo slew time will be 1 second.

$$\frac{2 \text{ seconds}}{2} = 1 \text{ second average} + 0.02 \text{ seconds writing time}$$

$$= 1.02 \text{ seconds}$$

or, approximately 1 target per second.

Assuming an increase in writing speed of a factor of 4, the random writing speed will then be

$$1 + \frac{(0.02)}{4} = 1.005$$

Writing speed is then $\frac{1}{1.005} = 0.995$ targets per second, or an insignificant reduction in capability. In typical operation with a computer, a random plotting mode will be used, so the writing speed is essentially limited by electromechanical considerations.

4.7.7 Future Systems. In future systems, a dot writing speed of 5 milliseconds and a servo slew time of about 250 milliseconds can be reasonably expected. In this case, the average random writing speed for a one-arm system will be $\frac{250}{2} + 5 = 130$ or 7.7 targets per second.

For a four-arm system, the speed will be $\frac{250}{2} + 4(5) = 125 + 20 = 145$ or 6.9 targets per second, which is again a small reduction in random writing capability.

Since the optical writing speed is so much faster than the mechanical speed (and this difference in speed is very likely to continue), the speed of the on-axis system is not too much less than the off-axis system with equivalent growth potential.

4.8 CRT FIBER-OPTIC PHOTOCROMIC DISPLAY. An alternative type of display system proposed for the Data Display Study employs a fiber-optic cathode-ray tube. In the fiber-optic system, a fiber-optic cathode-ray tube is the light source for writing on photochromic materials. This system is illustrated in Figure 26. As

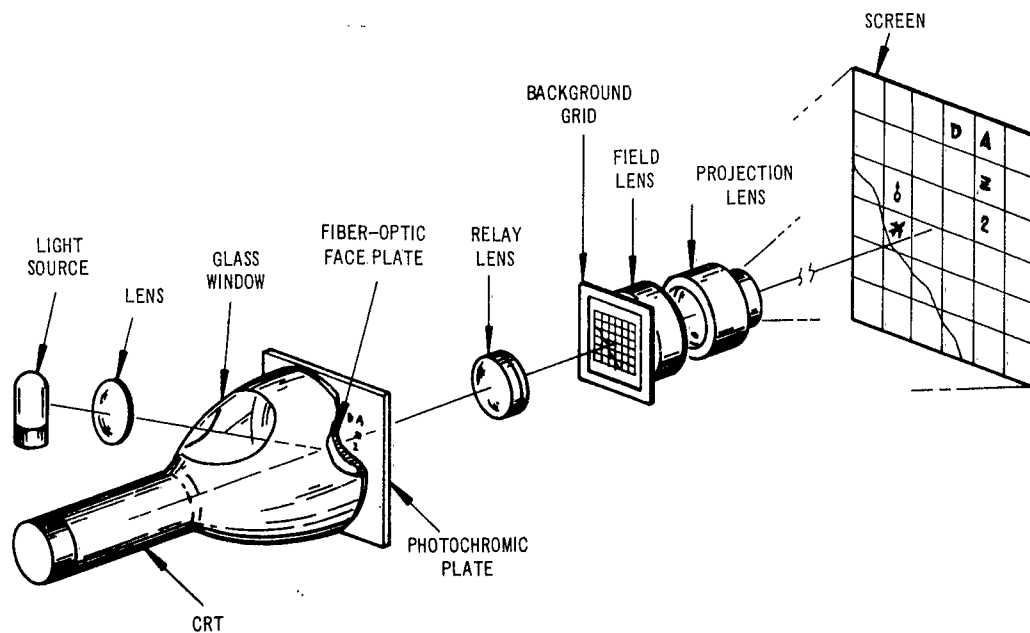

3520-16

Figure 26. CRT Fiber-Optic Display System

shown in the schematic, the photochromic plate is located in close proximity to the fiber-optic face plate. On the opposite side of the face plate is an ultraviolet phosphor coating. The ultraviolet light output of the phosphor coating is directed through the fiber optics onto the photochromic plate. A projection light illuminates the dynamic data generated and stored on the photochromics, and projects this data onto the screen. If a background grid is desired, a series arrangement of relay lens and background grid may be employed.

4.8.1 CRT Photochromic Writing Techniques. Prior to the present Data Display Study, NCR had performed research in cathode-ray tube photochromic writing techniques. A review of this previous work is presented as background to subsequent effort continued under this program. Initial tests were conducted using a 5ZP16 cathode-ray tube and conventional optics. Using this technique, spot exposure required 12 seconds because of a limitation of the phosphor cooling time of this particular cathode-ray tube. The photochromic material could have been exposed in 24 milliseconds. The heat transfer limitations of the CRT phosphor, however, required that the energy be delivered by 2400 pulses, of 10 microseconds duration, at a repetition rate of 200 cps. Although the cathode-ray tube phosphor can be actuated and reach a maximum temperature in microseconds, milliseconds are required for sufficient cooling before reactivating.

In the two to three years since conducting the 5ZP16 cathode-ray tube tests, several advances have been made in cathode-ray tube technology. A fiber-optic faceplate provides about 40 times improvement over conventional cathode-ray tube optic systems, reducing the exposure time to 300 milliseconds. Additional improvements in the phosphor light spectrum and phosphor brightness are claimed to provide another factor of 8 times improvement, yielding a 37.5 millisecond exposure time.

4.8.2 Fiber-Optic Cathode-ray Tube Tests. A manufacturer of cathode-ray tubes was visited for the purpose of evaluating and testing a new fiber-optic tube. In this new device, the tube face is approximately 5 inches in diameter. Contained in the tube is a fiber-optic insert approximately 3 inches in diameter. An internal character mask provides 64 characters. The fiber-optic insert was made of three to five micron fibers by Mosaic Fabrications. Character height was approximately 50 mils. Three phosphors, P11, P16, and P22, each measuring approximately 1 inch in width, were distributed over the face of the fiber-optic insert.

Under the operating parameters listed in Table 3, initial tests of this new cathode-ray tube device indicated the relative merits of the three phosphors.

TABLE 3. CRT TEST CONDITIONS

CHARACTERISTIC	SPECIFICATIONS
Character On-Time	500 microseconds
Accelerating Ultor Voltage	24 kv
Beam Current	10 microampere during pulse period
Spot Diameter	4 mils approximately
Off-Time for Sequential Scanning	500 microseconds

Exposure of the photochromic material requires the application of 125 pulses. A duty cycle of approximately 10 to 1 was necessary to prevent phosphor burn. Exposures indicated that P16 produced the best exposure; P22 was approximately one-half as effective, and P11 approximately one-fourth as effective.

The cathode-ray tube manufacturer stated that the deflection time from one character position to the next may be accomplished in 30 microseconds. To efficiently use the cathode-ray tube, with a duty cycle limitation of 10 to 1, nine additional characters can be written while waiting for the phosphor to cool before the first character can be rewritten. Then, from 1 to 10 characters can be written in approximately the same time interval. With these restrictions, the time for each cycle is calculated as follows

$$\begin{aligned}
 \text{Time per cycle} &= \text{Pulse time} + \text{deflection time} \times 10 \\
 &= (500 + 30) 10 \\
 &= 5300 \text{ microseconds}
 \end{aligned}$$

The repetition rate per character is

$$\frac{1}{5300 \times 10^{-6}} = 189 \text{ times per second}$$

Since approximately 125 pulses are required to expose a character, 10 characters can be written in

$$\frac{125}{189} = 0.66 \text{ seconds}$$

This is an effective character writing rate of 15 characters per second. Because of the

cathode-ray tube limitations one character cannot be written in less time than 10 characters.

4.8.3 Preliminary System Design. A preliminary system design was initiated to explore the system implications of the fiber-optic CRT photochromic system. To provide a meaningful design, the characteristics of the CRT previously tested by NCR were used. The input data was established as 10 characters to be plotted in approximately 1 second. To simplify the digital design, 40-bit character parallel output from a buffer or data processor was assumed. A 500-microsecond pulse time per character was used. An assumption was that each character would have to be rewritten approximately 200 times before the characters were written on the photochromics. Dimensional specifications for a typical character are illustrated in Figure 27. A plotting accuracy of 0.5 percent of display size was also specified. These characteristics are summarized in Table 4.

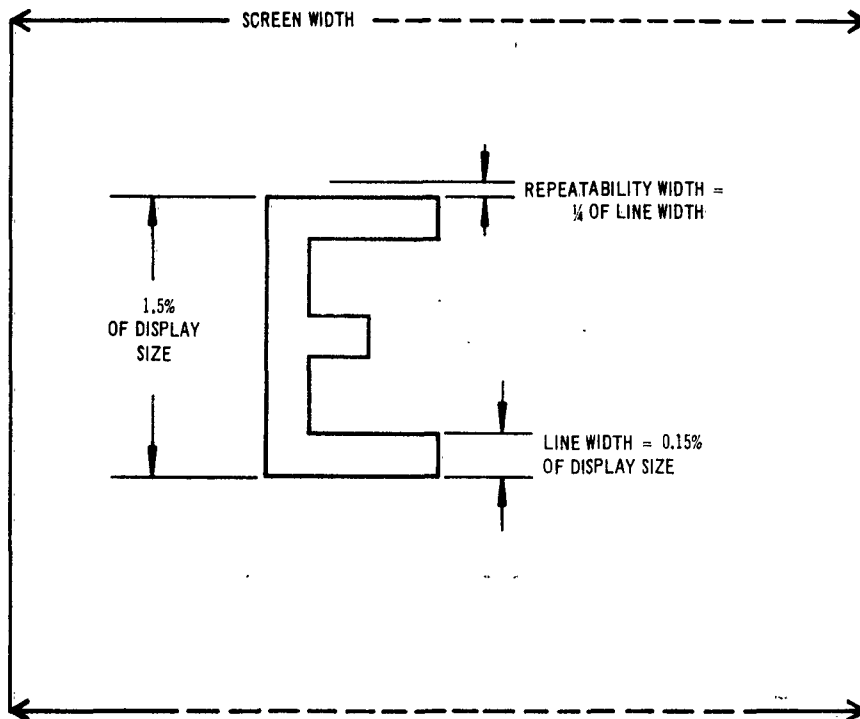

3520-17

Figure 27. Character Specifications

TABLE 4. PRELIMINARY SYSTEM CHARACTERISTICS

CHARACTERISTIC	SPECIFICATION
Data Input	10, 40-bit words per second
CRT - Fiber-Optic Size	3 by 3-inch maximum
Resolution	1000 lines
Repeatability	0.025% of display size
Accuracy	0.5% of display size
Unblanking Pulse	500 μ secs
Duty Cycle	10%
Total Exposure	200 pulses per character

4.8.4 Magnetic Deflection. One of the first parameters to establish is the type of deflection to be used: magnetic or electrostatic. Magnetic deflection has three primary advantages.

- a. Better resolution at high luminescence levels.
- b. Ease of obtaining large deflection forces by increasing signal currents rather than by developing large signal voltages.
- c. Associated gun structure is more compact and rugged, allowing a shorter tube for a given face size.

There are two significant disadvantages of magnetic deflection.

- a. High yoke inductance, precluding fast waveforms.
- b. Both absolute and incremented deflections are nonlinear for substantial deflection angles.

The nonlinear deflection is caused by the fact that the sine of the deflection angle for uniform yokes is proportional to current; actual spot deflection on a flat face tube is proportional to the tangent of the angle (better quality yokes have very nearly uniform fields). Thus, spot position departs from linearity with respect to current by the difference between the sine and tangent of the deflection angle. At 20° off-axis, this difference amounts to 6.4 percent error, and at 10° , the difference is 1.53 percent error. Corrections are very cumbersome since any correction needed for a given X-deflection is a function of the instantaneous Y-deflection as well as tube geometry

and applied potentials. A simple remedy can be effected by increasing the distance between the yoke center and the tube face. This increased distance reduces the required deflection angle, provided the longer tube can be tolerated in the equipment package. Since the desired overall position accuracy is 0.5 percent and this error is probably the largest contribution, an allocation of a 0.3 percent to this source would be reasonable. The deflection angle would then have to be limited to $\pm 4.5^\circ$. For a 3 by 3-inch display area, the phosphor would have to be 19.1 inches from the yoke center, or 28 inches overall. For a 2 by 2-inch area, the required size would be approximately 22 inches overall.

4.8.5 Electrostatic Deflection. In electrostatic deflection, the spot position is a linear function of the deflection voltage for a uniform electrostatic deflection field. In practice, however, the fields may not be uniform because of fringing. Also, the plates are usually shaped to widen plate separation distance at the trailing edges. The plate separation distance is widened so that the bundle of electrons will not be intercepted as they leave the field. For these reasons, deflection sensitivity and linearity are usually established by measurement, and deflection plate geometry is often determined empirically.

Another problem sometimes encountered is a partial defocusing of the beam by disturbances in the electric field between the plates and the anode resulting in astigmatism. These difficulties will be greatly alleviated by limiting the deflection angle, assuming that a long tube is acceptable. Plates 2 inches long with 1/4-inch separation and 18 kv accelerating potential would require 350 volts for 4.5° deflection. At 10 kv accelerating potential, 200 volts would be required. Push-pull deflection voltages should always be applied to the plates to minimize defocusing. The power supplies should be arranged to place the cathode-ray tube cathode at a negative potential so that the deflection plates can be operated near ground potential.

4.8.6 Deflection Choice. Consideration was given to the possibility of driving the yoke directly from the converter for the digital-to-analog conversion to eliminate possible inaccuracies which might be introduced by the amplifier. On examination, however, the use of an amplifier not only provides sufficient accuracy, but avoids complication and errors. Two digital-to-analog converters would be required to deflect both sides of center. Also, the resistance of the coil will affect the current for any given input to the converter, and the resistance of copper changes about 4 percent for a temperature change of 10°C .

Since the deflection speed to be used is relatively slow, because of the relative ease of obtaining linear deflection circuitry, and since the repeatability of a magnetic deflection is good, a magnetic deflection system was considered for X-Y positioning of the beam. Because of the high speed required, electrostatic deflection would be required for character selection.

4.8.7 Accuracy and Repeatability. A yoke deflection amplifier employing feedback (see Figure 28) can reasonably be expected to be accurate within 0.08 percent rms as

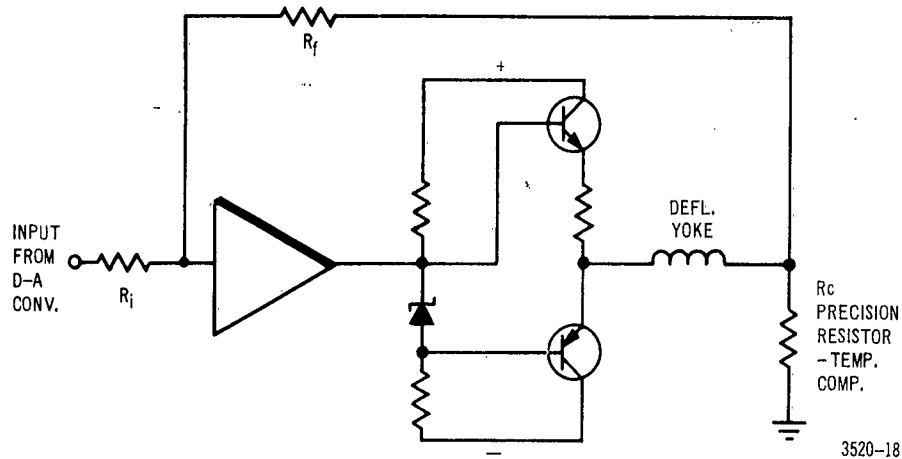

Figure 28. Yoke Deflection Amplifier

indicated by the summary of estimated errors in Table 5. Assuming a deflection geometry error of 0.3 percent, and an estimated 0.2 percent for the yoke, a character position error of 0.222 percent rms with respect to the digital input information can be expected. Or, based on the following assumptions, 95 percent confidence can be placed in a character position error of less than 0.45 percent.

TABLE 5. SUMMARY OF ESTIMATED AMPLIFIER ERRORS

ERROR SOURCE	EST VALUE	STD DEV (%)	VARIANCES
D-to-A Conversion Error	$\pm 0.05\%$	0.029	0.00084
Amplifier Drift	± 0.10 mv	0.038	0.00144
Amplifier Noise	2 mv rms	0.0125	0.000156
Tolerance of Series Register	$\pm 0.1\%$	0.057	0.0033
Static Error of Servo Loop	$\pm 0.01\%$	0.0057	0.000033
Total for Converter and Amplifier		0.076	0.0058

Regarding repeatability, all sources of error except amplifier noise are either systematic or change so slowly as to introduce negligible differences within the time of 200 repeated exposures. Therefore, the best estimate of repeatability error is 0.0125 percent rms.

4.8.8 Character Generation. Three character generation techniques have been considered: shaped beam, line trace, and dot matrix. In the shaped beam, or Charactertron system, a character is generated by passing a collimated electron beam through a 64-character matrix; this beam is imaged on the phosphor coating. Using electrostatic deflection, character selection is controlled by an analog voltage which deflects the beam to a particular aperture in the matrix. The selected character is positioned by magnetic deflection. Because the characters originate within the cathode ray tube, the cost of the shaped beam system is very reasonable.

A line trace system operates by generating continuous X-Y waveforms for tracing characters on the cathode-ray tube faceplate. Several systems of this type are available at costs in the range of several thousand dollars. Repeatability of the output waveform is typically quoted as 1 percent of the character height.

A typical dot matrix accepts a 6-bit parallel input and generates a succession of X and Y voltage steps. Each voltage step is selected from 240 possibilities in a 15 by 16 field, unblanking the beam at each selection. Repeatability is typically quoted at 5 percent.

Because all of the three character generators described would probably be satisfactory, no further investigations were conducted.

4.8.9 Data Handling. With the foregoing ground rules established, consideration was then given to the remainder of system requirements. It had already been established that ten 40-bit words are stored and recycled for 1 second. The recycled data is continuously fed into the CRT during the 1-second period. Since this requires 400 bits of storage, flip-flops and core storage would be too expensive. A delay line is suitable for this application and is used in the block diagram shown in Figure 29.

The computer is assumed to operate on a command basis, i. e., the display sends a ready signal to the computer when the display is ready to plot. The data processor or buffer outputs ten 40-bit words which are loaded into the delay line. Since the stored data is circulated at a 1-megacycle bit rate, allowing a 10-bit, or 10-microsecond, space for loading, deflection coil settling, etc., the average load time will be 50-microseconds. The cycle time for 10 words is 500 microseconds so that the exposure time will be 500 microseconds for each character with a cooling period of 5000 microseconds. During this cooling period, characters are cycled by the delay line readout, including the character being exposed. The second characters in sequence become available at the delay readout. All characters circulate through the delay line once

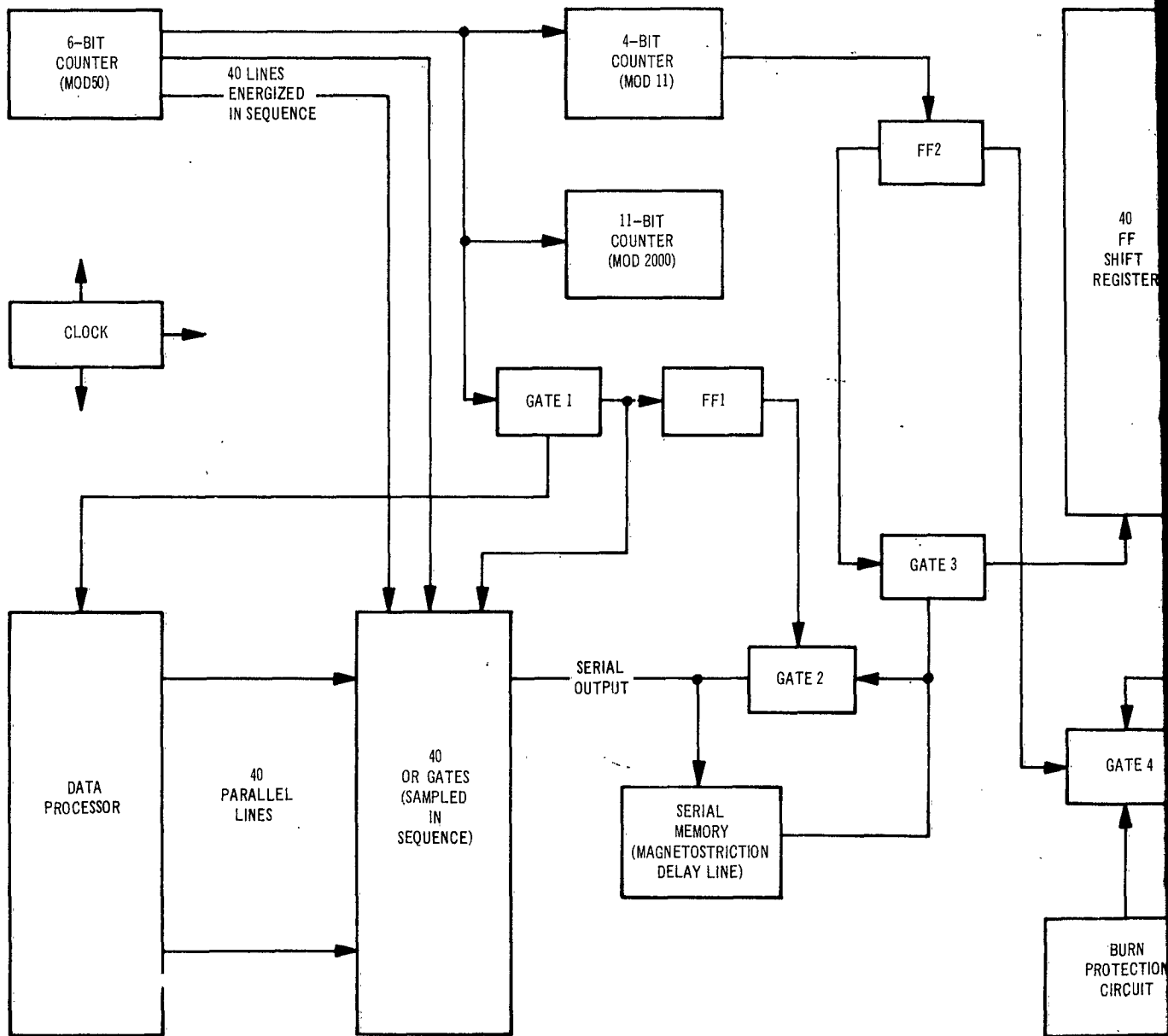
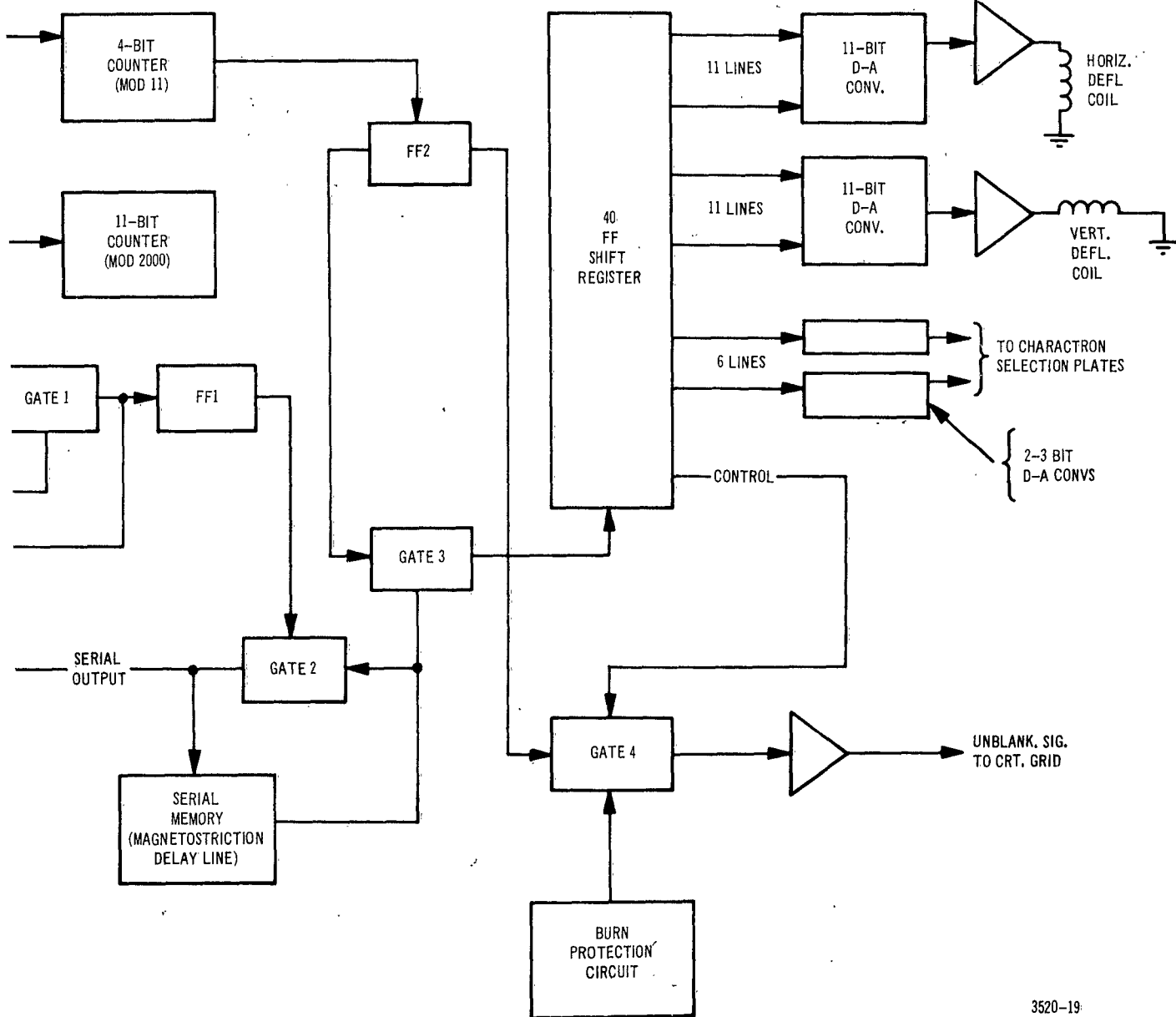

Figure 29. System Block Diagram (Using Charactron)

1



3520-19

Figure 29. System Block Diagram (Using Charactron)



for each exposure, and readout occurs every eleventh word-time.

Assume that 1-megacycle clock pulses are accumulated in a 6-bit counter operating mod 50. An output pulse is emitted every 50 microseconds which is accumulated in an 11-bit counter operating mod 2000 and also in a 4-bit counter operating mod 11. Gating associated with the 6-bit counter provides output pulses in sequence on 40 lines.

Flip-flop 1 is set by the 11-bit counter during the last 10 word-times (200th exposure cycle), enabling gate 1 so that a load command is sent to the computer at the completion of each word. On receipt of the load command pulse, the computer makes the next word available on 40 parallel output lines which then are sampled in sequence by 40 OR gates under control of 40 lines from the 6-bit counter. During this time, the OR gates are enabled by flip-flop 1 and gate 2 is disabled by flip-flop 1. When loading is completed, the 11-bit counter resets flip-flop 1 and gate 2 is enabled, allowing the information to circulate through the delay line.

During each eleventh word-time, flip-flop 2 is set by the 4-bit counter, enabling gate 3. Gate 3 allows the next word to be loaded into the 40-bit flip-flop shift register. At the same time, flip-flop 2 disables gate 4 to assure cathode-ray tube blanking. After the word is loaded, flip-flop 2 is reset by the 4-bit counter and the word is retained in the register for conversion to analog signals. Resetting flip-flop 2 also enables gate 4 so that the beam can be unblanked, provided other conditions are proper, as described in Paragraph 4.8.10.

The system illustrated in Figure 29 is suited particularly to the Charactron tube. As another possible arrangement, one of the character generators could be substituted for the two, 3-bit digital-to-analog converters, with the output X and Y waveforms connected to the deflection plates of a conventional cathode-ray tube. In this case, the character writing speed may be adjusted so that practically all of the 500-microsecond interval is consumed in forming the character. The beam current and accelerating potential is adjusted for maximum light output without phosphor damage within that time.

4.8.10 Phosphor Burn Protection Circuit. Provision is normally made to turn off the beam current during character changing, and to delay beam unblanking until the switching transients have dissipated from the deflection yokes. Additional precautions should be provided to assure that two succeeding characters are not inadvertently exposed at the same phosphor position. A suggested solution to this problem is the circuit shown in Figure 30.

The circuit stores the position of the last character and maintains the beam in the off condition unless the new character is to be exposed at a different position. The X and Y position voltages from the digital-to-analog converters or deflection amplifiers are summed into an operational amplifier through parallel RC circuits. Switches S1 and

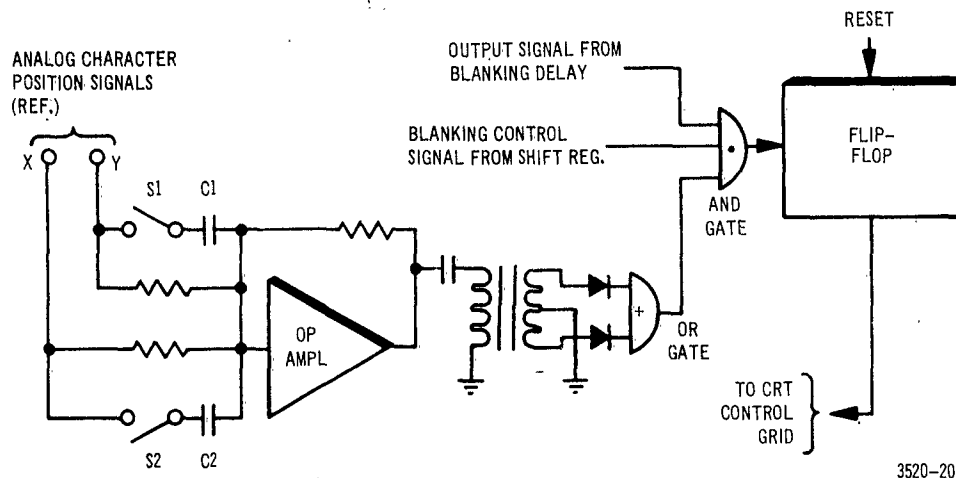

Figure 30. Phosphor Protection Circuit

S2 may be either transistor or diode switches. With switches S1 and S2 closed, capacitors C1 and C2 assume charges proportional to the X and Y deflection voltages. Switches S1 and S2 are opened before the character is changed; capacitors C1 and C2 remain charged. After the new character has been exposed and transients have dissipated, the AND gate is enabled by true signals from the blanking control signal. Switches S1 and S2 are then closed. If the new character position is the same as previously, C1 and C2 voltages will match the input position signals, there will be no change in the output, and the flip-flop will not be set. If either the X or Y position signal is different, however, the closing of S1 and S2 will apply a step function to the summing amplifier, causing an output pulse to set the flip-flop and turn on the beam. Switches S1 and S2 should not be closed in exact time coincidence, since cancellation of the charges on C1 and C2 would be possible, leaving the beam off for equal but opposite changes in X and Y. The blanking control signal from the shift register is true when a bit has been placed in the character word to indicate that the character should be exposed. Thus, by omitting that bit, any character can be blanked out of the group.

5. CONCLUSIONS

As a part of the Data Display Study, NCR has been exploring new techniques for advancing the state-of-the-art in display technology. Electromechanical and electronic systems are being considered:

- a. Theoretical operation of an electromechanical rotary wedge system has been verified. Practical operation of this system must be proven.

- b. Theoretical CRT photochromic operation has been analyzed and believed practical. Practical considerations such as repeatability, resolution, exposure time, etc., must be investigated further.

Since it cannot be predicted at this time which system will result in the most efficient, reliable, and inexpensive system, it is recommended that parallel effort be conducted until an intelligent choice of system implementation can be determined.

Artillery and Intelligence user display requirements are very similar except for dynamic color capability. Elimination of dynamic color plotting capability and substitution of meaningful symbology would make the user requirements so nearly identical that a single display technology could meet both requirements.

6. PROGRAM FOR NEXT QUARTER

- a. Determine practicality of rotating wedge writing system.
- b. Continue CRT Fiber Optic investigation to complete specifications for CRT.

7. IDENTIFICATION OF PERSONNEL

A brief resume of key personnel assigned to this contract is provided in this first quarterly report. A report of the approximate man-hours of work expended by each of these personnel will be furnished in a supplemental report.

HARLEY L. BJELLAND

Engineering Development Manager at NCR, responsible for the supervision of all phases of military engineering development. B.S. in Electrical Engineering from the Milwaukee School of Engineering; graduate courses at University of Maryland, UCLA, and University of California. NCR Electronics Division: photochromic display systems, servomechanisms, optics, digital systems, advanced display techniques. Lockheed Missiles: missile system checkout equipment. Melpar Corporation: digital control unit, high-speed film titling. Naval Research Laboratory: analysis and development of nanosecond sweep circuits, nuclear instrumentation.

DAVID A. GRAFTON

Senior Research Engineer at NCR Electronics Division; B.S. in Engineering at Brighton Technical College; RAF Radar Course; Hull Technical College. NCR Electronics Division: CRT research, photochromic display, photochromic memory system. IBM: photoscopic memory. International Telemeter Corporation: CRT photoscopic memory, high resolution photography. Patent pending for Optical Storage System and Optical Information Display System. Coauthored paper on Photochromic Micro-image Memory, presented May 1961, ONR Symposium.

STEPHAN M. MAK

B.S., M.S. in Electrical Engineering at California Institute of Technology; UCLA graduate courses. NCR Electronics Division: Mark 20 Graphic Display System, Optical Scan Pen System, Mark 4 Control-Display System, digital computers. American Electronics Corporation; airborne analog computer. Member, IRE.

WILLIAM LEISNER

B.S. in Physics at Los Angeles State College. Fenske Fedrick & Miller Inc.: optical display devices Project Engineer. General Electric Missile and Space Vehicle Department: Optical Engineer in optical instrumentation using ultraviolet, visible or infra-red radiation. Northrop Space Labs: member of research staff on space vehicle optical equipment. Member, Infra-red Information Society, Optical Society of America.

8. DISTRIBUTION LIST

OASD (R&E), Rm 3E1065
ATTN: Technical Library
The Pentagon
Washington 25, DC 1

Chief of Research and Development
OCS, Department of the Army
Washington 25, DC 1

Commanding General
U. S. Army Materiel Command
ATTN: R&D Directorate
Washington 25, DC 1

Commanding General
U. S. Army Electronics Command
ATTN: AMSEL-AD
Fort Monmouth, N. J. 3

Commander, Armed Services Technical Information Agency*
ATTN: TISIA
Arlington Hall Station
Arlington 12, Virginia 10

Commanding General
U. S. A. Combat Developments Command
ATTN: CDCMR-E
Fort Belvoir, Virginia 1

Commanding Officer
U. S. A. Communication and Electronics Combat Development Agency
Fort Huachuca, Arizona 1

Chief, U. S. Army Security Agency
Arlington Hall Station
Arlington 12, Virginia 2

* "Qualified requestors may obtain copies of this report from ASTIA. ASTIA release to OTS not authorized."

Deputy President U. S. Army Security Agency Board Arlington Hall Station Arlington 12, Virginia	1
Director, U. S. Naval Research Laboratory ATTN: Code 2027 Washington 25, DC	1
Commanding Officer and Director U. S. Navy Electronics Laboratory San Diego 52, California	1
Aeronautical Systems Division ATTN: ASAPRL Wright-Patterson Air Force Base, Ohio	1
Air Force Cambridge Research Laboratories ATTN: CRZC L.G. Hanscom Field Bedford, Massachusetts	1
Air Force Cambridge Research Laboratories ATTN: CRZC L. G. Hanscom Field Bedford, Massachusetts	1
Air Force Cambridge Research Laboratories ATTN: CRXL-R L. G. Hanscom Field Bedford, Massachusetts	1
Hq, Electronic Systems Division ATTN: ESAT L. G. Hanscom Field Bedford, Massachusetts	1

Rome Air Development Center ATTN: RAALD Griffiss Air Force Base, New York	1
AFSC Scientific/Technical Liaison Office U. S. Naval Air Development Center Johnsville, Pennsylvania	1
Commanding Officer U. S. Army Electronics Materiel Support Agency ATTN: SELMS-ADJ Fort Monmouth, New Jersey	1
Director, Fort Monmouth Office U. S. A. Communication and Electronics Combat Development Agency Fort Monmouth, New Jersey	1
Corps of Engineers Liaison Office U. S. Army Electronics Research & Development Laboratory Fort Monmouth, New Jersey	1
AFSC Scientific/Technical Liaison Office U. S. Army Electronics Research & Development Laboratory Fort Monmouth, New Jersey	1
Commanding Officer U. S. Army Electronics Research & Development Laboratory ATTN: Logistics Division Fort Monmouth, New Jersey (Marked for Project Engineer)	6
Commanding Officer U. S. Army Electronics Research & Development Laboratory ATTN: Director of Research/Engineering Fort Monmouth, New Jersey	1

Commanding Officer
U.S. Army Electronics Research & Development Laboratory
ATTN: Technical Documents Center
Fort Monmouth, New Jersey 1

Commanding Officer
U.S. Army Electronics Research & Development Laboratory
ATTN: SELRA/NP-4
Fort Monmouth, New Jersey 1

Commanding Officer
U.S. Army Electronics Research & Development Laboratory
ATTN: Technical Information Division
Fort Monmouth, New Jersey 3

Dr. Selig Starr
Office of Chief of Research and Development
Department of the Army
Washington 25, DC 1

Personnel System Development Office
Hq Command
U.S. Air Force
Bolling Air Force Base 25, DC 1

Commanding Officer Hq Rome Air Development Center
Research and Tech Division
ATTN: RAS GD
N. Tesselmen, Air Force Systems Command
U.S. Air Force, Griffiss AFB, New York 1

Mr. Lewis R. Blair Jr.
Television and Electronic Display Division
Audio Visual Comm Directorate
Office Chief Signal Officer
Room 5A466
Pentagon,
Washington, DC 1

Commanding General
U. S. Army Materiel Command
ATTN: AMCRD-RS-PE, Mr. A. Maklin
Bldg T-17
Gravelly Point, Virginia

1

Marine Corps Liaison Office
U. S. Army Electronics Research & Development Laboratory
Fort Monmouth, New Jersey

1

Commanding Officer Headquarters
Rome Air Development Center
Research and Technical Division
ATTN: RAS GD
N. Tesselman
Air Force Systems Command
U. S. Air Force
Griffiss AFB, New York

1

This contract is supervised by Mr. Erich F. Kral, Graphical Data Area, Data Division, Communications Department, U. S. Army Electronics Research and Development Laboratory, Fort Monmouth, New Jersey. Telephone Area Code 201 - 5352125.

Electronics Division, The National Cash Register Company, Hawthorne, California
FIRST QUARTERLY PROGRESS REPORT
ON DATA DISPLAY STUDY by H. Bjelland.
Report for 1 December 1962 to 1 March 1963. 56 pages including illustrations, Signal Corps Contract DA36-039 SC 90855 Unclassified Report.

State-of-the-art in Photochromic Displays is discussed. Comparisons are made of Army Artillery and Army Intelligence display parameters. Two possible techniques of advancing the state-of-the-art of the photochromic display technology are described: one electromechanical, and one electronics that uses a CRT for writing on photochromics.

UNCLASSIFIED

UNCLASSIFIED

Electronics Division, The National Cash Register Company, Hawthorne, California
FIRST QUARTERLY PROGRESS REPORT
ON DATA DISPLAY STUDY by H. Bjelland.
Report for 1 December 1962 to 1 March 1963. 56 pages including illustrations, Signal Corps Contract DA36-039 SC 90855 Unclassified Report.

State-of-the-art in Photochromic Displays is discussed. Comparisons are made of Army Artillery and Army Intelligence display parameters. Two possible techniques of advancing the state-of-the-art of the photochromic display technology are described: one electromechanical, and one electronics that uses a CRT for writing on photochromics.

Electronics Division, The National Cash Register Company, Hawthorne, California
FIRST QUARTERLY PROGRESS REPORT
ON DATA DISPLAY STUDY by H. Bjelland.
Report for 1 December 1962 to 1 March 1963. 56 pages including illustrations, Signal Corps Contract DA36-039 SC 90855 Unclassified Report.

State-of-the-art in Photochromic Displays is discussed. Comparisons are made of Army Artillery and Army Intelligence display parameters. Two possible techniques of advancing the state-of-the-art of the photochromic display technology are described: one electromechanical, and one electronics that uses a CRT for writing on photochromics.

UNCLASSIFIED

UNCLASSIFIED

Electronics Division, The National Cash Register Company, Hawthorne, California
FIRST QUARTERLY PROGRESS REPORT
ON DATA DISPLAY STUDY by H. Bjelland.
Report for 1 December 1962 to 1 March 1963. 56 pages including illustrations, Signal Corps Contract DA36-039 SC 90855 Unclassified Report.

State-of-the-art in Photochromic Displays is discussed. Comparisons are made of Army Artillery and Army Intelligence display parameters. Two possible techniques of advancing the state-of-the-art of the photochromic display technology are described: one electromechanical, and one electronics that uses a CRT for writing on photochromics.