

UNCLASSIFIED

AD NUMBER
AD407437
NEW LIMITATION CHANGE
TO Approved for public release, distribution unlimited
FROM Distribution authorized to U.S. Gov't. agencies and their contractors; Administrative/Operational Use; 23 MAY 1963. Other requests shall be referred to Air Force Electronic Systems Division, Hanscom AFB, MA.
AUTHORITY
MIT/LL 2 May 1966

THIS PAGE IS UNCLASSIFIED

**UNCLASSIFIED**

**AD 407 437** \_\_\_\_\_

**DEFENSE DOCUMENTATION CENTER**

**FOR**

**SCIENTIFIC AND TECHNICAL INFORMATION**

**CAMERON STATION, ALEXANDRIA, VIRGINIA**



**UNCLASSIFIED**

**NOTICE:** When government or other drawings, specifications or other data are used for any purpose other than in connection with a definitely related government procurement operation, the U. S. Government thereby incurs no responsibility, nor any obligation whatsoever; and the fact that the Government may have formulated, furnished, or in any way supplied the said drawings, specifications, or other data is not to be regarded by implication or otherwise as in any manner licensing the holder or any other person or corporation, or conveying any rights or permission to manufacture, use or sell any patented invention that may in any way be related thereto.

MASSACHUSETTS INSTITUTE OF TECHNOLOGY  
LINCOLN LABORATORY

22G-9

TIME- AND FUEL-OPTIMAL ATTITUDE CONTROL

407437

Michael Athans

23 May 1963

jmk

The work reported in this document was performed at Lincoln Laboratory, a center for research operated by Massachusetts Institute of Technology, with the joint support of the U. S. Army, Navy and Air Force under Air Force Contract AF 19(628)-500.

LEXINGTON

MASSACHUSETTS

No OTS

When issued, this document had not been reviewed or released for public dissemination by the appropriate government agency. Reproduction or distribution for official government use is authorized. Other reproduction or distribution requires written authorization by Lincoln Laboratory Publications Office.

Upon notification of release, this page may be removed.

DDC  
RECEIVED  
JUN 14 1963  
JTSIA 0

## ABSTRACT

The problem of attitude control of a body described by the equation  $I\ddot{\theta}(t) = \tau(t)$  is examined, where  $I$  is the moment of inertia,  $\theta(t)$  is the angular displacement, and  $\tau(t)$  is the torque exerted by the reaction jets. There exists a magnitude restriction on the torque, i. e.,  $|\tau(t)| \leq M$  and, in addition,  $\theta(t)$  lies in the interval  $-\pi \leq \theta(t) \leq \pi$ . Under these restrictions the time-optimal and the fuel-optimal control laws are derived and the design of the corresponding optimal controllers is presented.

AFESD - TDR - 63 - 61

## 1. INTRODUCTION

Second order systems described by a differential equation of the form  $\ddot{y}(t) = f(t)$ ,  $|f(t)| \leq 1$ , have received considerable attention by various investigators. The time-optimal control of such systems is treated in Refs. 1, 2, 3, and 4. Recently, the fuel-optimal control of such systems has been considered. Reference 5 contains the elements of fuel-optimal control with unrestricted response time. References 6 and 7 deal with the fuel-optimal control where the response time is fixed a priori. Reference 8 contains the techniques of fuel-optimal control with an upper bound on the response time.

A common characteristic of the results available to date is the assumption that the (output) variable  $y(t)$  can be measured and that its values lie in the interval  $-\infty < y(t) < +\infty$ . If such is the case, then the problem of forcing  $y(t)$  and  $\dot{y}(t)$  to zero in minimum time is solved and the solution is well known: one divides the phase plane into two regions by means of the "switch" curve such that in one side  $f(t) = +1$  and on the other  $f(t) = -1$ . Similarly, for the fuel-optimal problem the phase plane is divided into three regions such that in the first region  $f(t) = +1$ , in the second  $f(t) = 0$ , and in the third  $f(t) = -1$ . Moreover, one can design simple nonlinear feedback controllers for minimum-time and minimum-fuel control. It must be emphasized that these results are valid if and only if  $-\infty < y(t) < \infty$ .

In this paper the attitude control problem of a system described by the differential equation  $I\dot{\theta}(t) = \tau(t)$ ,  $|\tau(t)| \leq M$ ,  $-\pi \leq \theta(t) \leq \pi$  is considered. Note that an additional restriction on the values of the angular displacement variable  $\theta(t)$  is imposed. It will be shown that this restriction on  $\theta(t)$ , which is the result of the inability of the measuring instruments to distinguish between an angle  $\theta(t)$  and an angle  $\theta(t) \pm 2n\pi$ , changes significantly both the time-optimal and the fuel-optimal control laws. Engineering realizations of the optimal control laws will also be given and their operation will be explained.

## 2. THE PHYSICAL SYSTEM

Consider a body rotating in a plane as illustrated in Fig. 1. The rotation of the body can be controlled by the reaction jets which provide a thrust  $f(t)$ . Let  $I$  denote the moment of inertia of the body about an axis perpendicular to the plane of rotation and passing through the center of mass. Let  $\tau(t)$  be the torque produced by the reaction jets, i. e.

$$\tau(t) = c f(t) \quad . \quad (1)$$

In the absence of friction, the differential equation of the rotating body is

$$I \ddot{\theta}(t) = \tau(t) \quad . \quad (2)$$

Since the measuring instruments cannot distinguish between an angle  $\theta(t)$  and an angle  $\theta(t) + 2n\pi$ ,  $n = 1, 2, \dots$ , the angular position  $\theta(t)$  is restricted by

$$-\pi \leq \theta(t) \leq \pi \quad . \quad (3)$$

The reaction jets deliver a thrust  $f(t)$  which is bounded, i. e.

$$|f(t)| \leq F \quad . \quad (4)$$

Define  $u(t)$  by

$$u(t) = \frac{c f(t)}{I} \quad . \quad (5)$$

Clearly,  $|u(t)| \leq M$ , where  $M = c F/I$ . For the sake of simplicity let  $M = 1$  and so the magnitude restrictions on the control variable  $u(t)$  are

$$|u(t)| \leq 1 \quad (6)$$

for all  $t$ . Define the state variables  $x_1(t)$  and  $x_2(t)$  by

$$x_1(t) = \theta(t) \quad ; \quad x_2(t) = \dot{\theta}(t) \quad . \quad (7)$$

Then the  $x_1(t)$  and  $x_2(t)$  state variables satisfy the differential equations

$$\left. \begin{aligned} \dot{x}_1(t) &= x_2(t) \\ \dot{x}_2(t) &= u(t) \end{aligned} \right\} \quad (8)$$

where  $x_1(t)$  is restricted by

$$-\pi \leq x_1(t) \leq +\pi \quad (9)$$

for all  $t$ .

### 3. THE TIME-OPTIMAL PROBLEM

The minimum-time control problem for the rotating body is:

Given the system described by Eq. (8) with the control  $u(t)$  restricted by Eq. (6) and with the  $x_1(t)$  variable restricted by Eq. (9), determine the control which will force any state to the zero state in minimum time.

It is well known that for a second order system, such as the rotating body considered here, the time-optimal control  $u(t)$  is either  $+1$  or  $-1$  and it may switch from  $+1$  to  $-1$  or from  $-1$  to  $+1$  at most once (see for example Ref. 4). It is desired to find the value of the control for every possible state  $(x_1, x_2)$  where  $-\pi \leq x_1 \leq +\pi$ .

The method of attack is as follows: A family of curves will be defined which will divide the state plane (i. e. the strip of the  $x_1 - x_2$  plane defined by  $-\pi \leq x_1 \leq +\pi$ ,  $-\infty < x_2 < \infty$ ) into several regions. For each point in the state plane the value of the control which will provide the solution to the time-optimal problem will be stated. The elements of the proof of the time-optimality will follow.

Definition 1. Consider the family of curves in the state plane described by the equation

$$x_1 = n\pi - \frac{1}{2}x_2|x_2| \quad (10)$$

where

$$n = 0, \pm 1, \pm 2, \dots \quad (11)$$

and

$$-\pi \leq x_1 \leq +\pi \quad (12)$$

A state  $(x_1, x_2)$  which, for a particular value of  $n$ , satisfies Eq. (10) is said to belong to the  $\gamma_n$  curve.

Several of the  $\gamma_n$  curves are shown in Fig. 2. Some properties of the  $\gamma_n$  curves will now be developed.

Let  $u(t) = \Delta = \pm 1$  in Eq. (8) and solve for  $x_1(t)$  and  $x_2(t)$  using the initial conditions

$$x_1(0) = \xi_1 \quad ; \quad x_2(0) = \xi_2 \quad (13)$$

The state variables as functions of time are found to be

$$\left. \begin{aligned} x_1(t) &= \xi_1 + \xi_2 t + \frac{1}{2} \Delta t^2 \\ x_2(t) &= \xi_2 + \Delta t \end{aligned} \right\} \quad (14)$$

Eliminating the time  $t$  in the above equations one finds the equation of a trajectory in the state plane

$$x_1 = \xi_1 + \frac{1}{2} \Delta x_2^2 - \frac{1}{2} \Delta \xi_2^2 \quad ; \quad \Delta = \pm 1 \quad (15)$$

which joins the state  $(\xi_1, \xi_2)$  with the state  $(x_1, x_2)$  when the control is  $u(t) = \Delta = \pm 1$ .

Consider the portion of the  $\gamma_0$  curve above the  $x_1$  axis, which is labeled  $\gamma_{0-}$  in Fig. 2. The equation of the  $\gamma_{0-}$  curve is obtained from Eq. (9) using  $n = 0$  and  $x_2 > 0$ ; therefore

$$x_1 = -\frac{1}{2} x_2^2 \quad (16)$$

Now in Eq. (15) let  $\Delta = -1$  and  $x_1 = x_2 = 0$  to find

$$\xi_1 = -\frac{1}{2} \xi_2^2 \quad (17)$$

Equations (16) and (17) are identical and one concludes that every point on the  $\gamma_{0-}$  curve can be forced to  $(0, 0)$  using  $u(t) = -1$ . Similarly, one finds that every point on the  $\gamma_{0+}$  curve (which is the portion of the  $\gamma_0$  curve below the  $x_1$  axis) can be forced to  $(0, 0)$  using  $u(t) = +1$ . As a matter of fact the  $\gamma_0$  curve is the portion of the switch curve (see Refs. 1, 2, 3, 4) in the strip defined by  $-\pi \leq x_1 \leq +\pi$ .

Now consider the  $\gamma_2$  curve whose equation is

$$x_1 = 2\pi - \frac{1}{2} x_2^2 \quad (18)$$

obtained from Eq. (9) using  $n = 2$  and  $n_2 > 0$ . The  $\gamma_2$  curve hits the line  $x_1 = \pi$  at the point  $(\pi, \sqrt{2\pi})$ . Now consider the equation of the trajectory obtained from Eq. (15) with  $\Delta = -1$ ,  $x_1 = \pi$  and  $x_2 = \sqrt{2\pi}$ . This trajectory has the equation

$$\xi_1 = 2\pi - \frac{1}{2} \xi_2^2 \quad (19)$$

Equations (18) and (19) are identical and one concludes that every point on the  $\gamma_2$  curve can be forced to the point  $(\pi, \sqrt{2\pi})$  using  $u(t) \pm -1$ . However, the points  $(-\pi, \sqrt{2\pi})$  and  $(\pi, \sqrt{2\pi})$  are equivalent and one may conclude that every point on the  $\gamma_2$  curve can be forced to  $(0, 0)$  using  $u(t) = -1$  and that the path is the  $\gamma_2$  curve until the point

$(\pi, \sqrt{2\pi})$  is reached and then the  $\gamma_{0-}$  curve. Using similar reasoning one establishes the following propositions.

**Proposition 1.** Any point on the  $\gamma_{0-}, \gamma_2, \gamma_4, \gamma_6, \dots$  curves can be forced to  $(0, 0)$  using  $u(t) = -1$  and the path followed consists of the  $\gamma_{0-}, \gamma_2, \gamma_4, \gamma_6, \dots$  curves.

**Proposition 2.** Any point on the  $\gamma_{0+}, \gamma_{-2}, \gamma_{-4}, \gamma_{-6}, \dots$  curves can be forced to  $(0, 0)$  using  $u(t) = +1$  and the path followed consists of the  $\gamma_{0+}, \gamma_{-2}, \gamma_{-4}, \gamma_{-6}, \dots$  curves.

These two propositions establish properties of the  $\gamma_n$  curves for even values of  $n$ .

**Definition 2.** The statement "apply first the control  $u^1$  and then the control  $u^2, \dots$ " will be abbreviated by "apply the control sequence  $\{u^1, u^2, \dots\}$ ."

The properties of the  $\gamma_n$  curves, for  $n$  odd, will now be derived. Consider a state  $X = (x_1, x_2)$  in the region between the  $\gamma_0$  curve and the  $\gamma_2$  curve as illustrated in Fig. 3. There are two ways of reaching the origin  $(0, 0)$  using a control which switches only once. One way is to apply the control sequence  $\{-1, +1\}$ , i.e. to apply  $u(t) = -1$  until the trajectory reaches the  $\gamma_{0+}$  curve at the point  $Y$  and then apply  $u(t) = +1$  to reach the origin. Let the time required by the control sequence  $\{-1, +1\}$  be  $T_1$ . The trajectory resulting from the sequence  $\{-1, +1\}$  is  $XYO$  in Fig. 3. The other way is to apply the control sequence  $\{+1, -1\}$ , i.e. apply  $u(t) = +1$  until the trajectory hits the  $\gamma_2$  curve at the point  $Z$  and then apply  $u(t) = -1$  to reach  $(0, 0)$  along the  $\gamma_2$  and  $\gamma_{0-}$  curves (cf Proposition 1). The trajectory resulting from the control sequence  $\{+1, -1\}$  is  $XZAA'O$  in Fig. 3 and denote the time required by  $T_2$ .

It is easy to evaluate the times  $T_1$  and  $T_2$  required by the two methods of control, using Eq. (14). One finds

$$T_1 = x_2 - 2y_2 \quad (20)$$

and

$$T_2 = 2z_2 - x_2 \quad (21)$$

But from Eqs. (16) and (15)

$$y_2 = -\sqrt{x_1 + \frac{1}{2}x_2^2} \quad (22)$$

and from Eqs. (18) and (15)

$$z_2 = \sqrt{-x_1 + \frac{1}{2}x_2^2 + 2\pi} \quad (23)$$

Substituting Eq. (22) into Eq. (20) one finds

$$T_1 = x_2 - 2\sqrt{-x_1 + \frac{1}{2}x_2^2} \quad (24)$$

and from Eqs. (23) and (21)

$$T_2 = 2\sqrt{-x_1 + \frac{1}{2}x_2^2 + 2\pi} - x_2 \quad (25)$$

Now consider the set of states  $(x_1, x_2)$  with the property that

$$T_1 = T_2 \quad (26)$$

Such states must satisfy the equation

$$x_2 - 2\sqrt{-x_1 + \frac{1}{2}x_2^2} = 2\sqrt{-x_1 + \frac{1}{2}x_2^2 + 2\pi} - x_2 \quad (27)$$

which simplifies to, after a series of algebraic manipulations,

$$x_1 = \pi - \frac{1}{2}x_2^2 \quad (28)$$

From Eq. (10), setting  $n = 1$  and  $x_2 > 0$ , the equation of the  $\gamma_1$  curve is

$$x_1 = \pi - \frac{1}{2}x_2^2 \quad (29)$$

Equations (28) and (29) are identical and, so, one immediately concludes that the  $\gamma_1$  curve is a locus of points in the state plane which require the same time to reach the origin using either the control sequence  $\{+1, -1\}$ , or the control sequence  $\{-1, +1\}$ .

Using identical reasoning one can compute the locus of all points in the state plane which require the same time to reach the origin using either the control sequence  $\{+1, -1\}$  or  $\{-1, +1\}$ . For example, if one chooses an initial state in the region between the  $\gamma_2$  and  $\gamma_4$  curves, one will find that the  $\gamma_3$  curve is the locus of points which require the same time to reach the origin using either the control sequence  $\{+1, -1\}$  or

$\{-1, +1\}$ . Thus, one can establish the following proposition.

**Proposition 3.** Any point on the  $\gamma_n$  curves for odd values of  $n$  can be forced to  $(0, 0)$  using either the control sequence  $\{+1, -1\}$  or the control sequence  $\{-1, +1\}$  and requiring the same response time in either case.

**Definition 3.** Let  $R_{m, m+1}$  denote the region which lies between the  $\gamma_m$  and  $\gamma_{m+1}$  curve. More precisely, the state  $(x_1, x_2)$  belong to the region (or set)  $R_{m, m+1}$  if

$$\left. \begin{aligned} & -\pi \leq x_1 \leq +\pi \\ & 2(m\pi - x_1) < x_2 | x_2 | < 2((m+1)\pi - x_1) \end{aligned} \right\} \quad (30)$$

for  $m = 0, +1, +2, \dots$ . For example, the region  $R_{-2, -1}$  is the region between the  $\gamma_{-2}$  and the  $\gamma_{-1}$  curve.

The regions  $R_{m, m+1}$  are illustrated in Fig. 2.

**Theorem 1.** Given a state  $(x_1, x_2)$  in the state plane. The time-optimal control, that is the control which will force any state  $(x_1, x_2)$  to  $(0, 0)$  in the shortest possible time is

If  $(x_1, x_2) \in R_{m, m+1}$ , then  $u = (-1)^{m+1}$ .

If  $(x_1, x_2) \in \gamma_m$  and if  $m = 2, 4, 6, \dots$ , then  $u = -1$ .

If  $(x_1, x_2) \in \gamma_m$  and if  $m = -2, -4, -6, \dots$ , then  $u = +1$ .

If  $(x_1, x_2) \in \gamma_{0-}$ , then  $u = -1$ .

If  $(x_1, x_2) \in \gamma_{0+}$ , then  $u = +1$ .

If  $(x_1, x_2) \in \gamma_m$  for  $m$  odd, then  $u = -1$  or  $u = +1$  (the time response is the same).

The above theorem provides the value of the time-optimal control for each state in the state plane. The proof of Theorem 1 is given in Appendix 1. The system shown in block diagram form in Fig. 4 represents an engineering realization of the control law given by the theorem and it will result in the minimum response time control of the rotating body.

The design and operation of the system of Fig. 4 is based on the following

reasoning. Define a function  $h_n$  by

$$h_n = x_1 - n\pi + \frac{1}{2}x_2|x_2| \quad . \quad (31)$$

Note that if

$$h_n = 0 \quad (32)$$

then the state  $(x_1, x_2)$  belongs to the  $\gamma_n$  curve (see Definition 1). If

$$h_n > 0 \quad (33)$$

then the state  $(x_1, x_2)$  is above the  $\gamma_n$  curve and, finally, if

$$h_n < 0 \quad (34)$$

then the state  $(x_1, x_2)$  is below the  $\gamma_n$  curve. As indicated in Fig. 4, the signals  $h_n$  are generated from the  $x_1$  and  $x_2$  state variables and a constant source providing the signal  $\pi$ . The only nonlinearity required is of the square law type, indicated by the block N in Fig. 4. The nonlinearity N is such that its output signal is  $\frac{1}{2}x_2|x_2|$  when the input signal is  $x_2$ . From the signal  $h_0$  the system generates all other signals  $h_n$  by repeated addition or subtraction of  $\pi$ .

Suppose that the measured state  $(x_1, x_2)$  is in the region  $R_{m, m+1}$ , that is the state lies between the  $\gamma_m$  and  $\gamma_{m+1}$  curves. Then the signals  $h_n$  will be:

$$\left. \begin{array}{l} h_i > 0 \quad \text{for all } i \leq m \\ h_i < 0 \quad \text{for all } i \geq m+1 \end{array} \right\} \quad . \quad (35)$$

For clarity, suppose that the signals  $h_2, h_3, h_4, \dots$ , are negative and that the signals  $h_1, h_0, h_{-1}, h_{-2}, \dots$ , are positive, as illustrated in Fig. 4. Then the measured state point  $(x_1, x_2)$  is between the  $\gamma_1$  and  $\gamma_2$  curve, i.e. it belongs to the Region  $R_{1, 2}$ . As shown in Fig. 4 each  $h_i$  signal activates a polarized relay with outputs +1 and -1. Let  $q_i$  be the output of the  $i^{\text{th}}$  relay, i.e.  $q_i = \text{sgn} \{h_i\} = \pm 1$ . For example, suppose that in Fig. 4  $q_2 = q_3 = q_4 = \dots = -1$  and  $q_1 = q_0 = q_{-1} = q_{-2} = \dots = +1$ . Connect the coils of normally open relays  $r_i$  between adjacent signals  $q_i$  and  $q_{i+1}$ , where the contact of the  $r_i$  relay is connected to a voltage  $(-1)^{i+1}$  and the outputs of all the relays

are connected to a common terminal. Only one of the relays  $r_1$  will be activated. For example, in the specific situation discussed above only the relay  $r_1$  will be closed and all the other relays will remain open, because there exists a voltage difference only across the coil of the relay  $r_1$  and there is no voltage drop across the coils of all the other relays. The signal at the common terminal will have the correct polarity to activate the relay-like mechanism of the gas jets which will now produce the correct thrust to drive  $\theta$  and  $\dot{\theta}$  to zero in minimum time.

In any physical situation one can expect a bound on the magnitude of the angular velocity  $x_2$ ; therefore the nonlinear computer of Fig. 4 would be terminated at the required number of stages.

#### 4. THE FUEL-OPTIMAL PROBLEM

The minimum-fuel attitude control problem for the rotating body is to drive  $\theta(t)$  and  $\dot{\theta}(t)$  to zero using as little gas (or fuel) as possible. More precisely:

Given the system described by Eq. (8) with the control  $u(t)$  restricted in magnitude by Eq. (6) and with the  $x_1(t)$  state variable restricted by Eq. (9), determine the control which will force any state to the zero state with minimum consumed fuel  $F$  measured by

$$F = \int_0^T k |u(t)| dt \quad (36)$$

where  $T$  is the response time (unspecified) and  $k$  is a positive constant of proportionality. Furthermore, if more than one control requires the same minimum fuel, then find the fuel-optimal control which requires the least response time.

It is well known (see Refs. 5, 6, 7, 8) that for a second order system, such as the rotating body considered in this paper, the fuel-optimal control  $u(t)$  is either +1, 0, or -1 and that the only control sequences (see Definition 2) that may be used are  $\{0\}$ ,  $\{+1\}$ ,  $\{-1\}$ ,  $\{+1, 0\}$ ,  $\{-1, 0\}$ ,  $\{0, +1\}$ ,  $\{0, -1\}$ ,  $\{+1, 0, -1\}$  and  $\{-1, 0, +1\}$ .

Consider the family of the  $\gamma_n$  curves (see Definition 1) described by

$$x_1 = n\pi - \frac{1}{2}x_2|x_2| \quad (37)$$

where

$$n = 0, \pm 2, \pm 4, \pm 6, \dots, \quad (38)$$

and

$$-\pi \leq x_1 \leq +\pi \quad (39)$$

This family of  $\gamma_n$  curves ( $n$  even) is shown in Fig. 5.

The fuel-optimal control law is provided by the theorem below.

Theorem 2. Given a state  $(x_1, x_2)$  in the state plane.

If  $(x_1, x_2)$  belongs to the  $\gamma_n$  curve for  $n = 2, 4, 6, \dots$ , then  $u = -1$ .

If  $(x_1, x_2)$  belongs to the  $\gamma_n$  curve for  $n = -2, -4, -6, \dots$ , then  $u = +1$ .

If  $(x_1, x_2)$  belongs to the  $\gamma_{0+}$  curve, then  $u = +1$ .

If  $(x_1, x_2)$  belongs to the  $\gamma_{0-}$  curve, then  $u = -1$ .

For all other points in the state plane  $u = 0$ .

The proof of this theorem is very similar to the proof presented in Ref. 5 and is, therefore, omitted for the sake of brevity. Figure 6 illustrates an engineering realization of the control law provided by Theorem 2. The signals  $h_n$ , for  $n = 0, \pm 2, \pm 4, \dots$ , are generated as explained before. If the state point belongs to the  $\gamma_i$  curve, then the  $h_i$  signal is zero. In Fig. 6 the signals  $h_0$  and  $x_1$  are used to generate the two signals  $h_{0-}$  and  $h_{0+}$ ; if  $h_{0-} = 0$ , then  $(x_1, x_2)$  belongs to the  $\gamma_{0-}$  curve and if  $h_{0+} = 0$ , then  $(x_1, x_2)$  belongs to the  $\gamma_{0+}$  curve. Each signal  $h_i$ ,  $i = \pm 2, \pm 4, \dots$ , and  $h_{0-}$  and  $h_{0+}$  activate normally closed relays so that a voltage of -2 volts appears on the common terminal if the state point is on the  $\gamma_{0-}, \gamma_2, \gamma_4, \dots$ , curves and a voltage of +2 volts appears only if the state belongs to the  $\gamma_{0+}, \gamma_{-2}, \gamma_{-4}, \dots$ , curves. For any other state the relays are open and no voltage appears at the terminal. Thus, the signals at the terminal can be used to open or close the reaction jets on the body and to deliver the correct thrust for minimum fuel operation.

If the bound on the magnitude of the angular velocity  $x_2$  is known, the computer of Fig. 6 would again have a finite number of stages.

## 5. DISCUSSION OF THE RESULTS

In the two previous sections the time-optimal and the fuel-optimal control laws were derived and the corresponding controllers were designed. In this section, equations for the response time and for the consumed fuel required by the time-optimal and by the fuel-optimal systems are presented.

Let  $t^*$  be the minimum time to force a given state  $(x_1, x_2)$  to  $(0, 0)$ . The minimum time  $t^*$  is determined from the formulae below:

$$t^* = \begin{cases} x_2 - 2\sqrt{x_1 + \frac{1}{2}x_2^2} - m\pi & \text{if } (x_1, x_2) \in R_{m, m+1} \text{ and } m = 0, 2, 4, 6, \dots \\ -x_2 + 2\sqrt{-x_1 + \frac{1}{2}x_2^2} + m\pi & \text{if } (x_1, x_2) \in R_{m, m+1} \text{ and } m = 1, 3, 5, 7, \dots \\ x_2 + 2\sqrt{x_1 + \frac{1}{2}x_2^2} - m\pi & \text{if } (x_1, x_2) \in R_{m, m+1} \text{ and } m = -2, -4, -6, \dots \\ -x_2 - 2\sqrt{-x_1 + \frac{1}{2}x_2^2} + m\pi & \text{if } (x_1, x_2) \in R_{m, m+1} \text{ and } m = -1, -3, -5, \dots \end{cases} \quad (40)$$

The fuel  $F^*$  consumed by the time-optimal system is given by

$$F^* = kt^* \quad (41)$$

since the fuel is measured by Eq. (36) and for the time-optimal system  $|u(t)| = 1$  and the response time is  $t^*$ .

Let  $T$  be the response time required by the fuel-optimal system. The response time  $T$ , as a function of  $x_1$  and  $x_2$ , is given below:

If

$$x_2 > 0 \quad (42)$$

find the value of  $m$ ,  $m = 0, 2, 4, \dots$ , such that

$$\sqrt{2\pi(m-1)} \leq x_2 \leq \sqrt{2\pi(m+1)} \quad (43)$$

Using the value of the determined  $m$  the response time is

$$T = \left\{ \begin{array}{ll} \frac{1}{x_2} \left\{ \frac{1}{2} x_2^2 + m\pi - x_1 \right\} & \text{if } x_1 \leq m\pi - \frac{1}{2} x_2^2 \\ \frac{1}{x_2} \left\{ \frac{1}{2} x_2^2 + (m+2)\pi - x_1 \right\} & \text{if } x_1 > m\pi - \frac{1}{2} x_2^2 \end{array} \right\} \quad (44)$$

If

$$x_2 < 0 \quad (45)$$

find the value of  $m$ ,  $m = 0, -2, -4, \dots$ , such that

$$-\sqrt{-2\pi(m-1)} \leq x_2 \leq -\sqrt{-2\pi(m+1)}$$

Using the value of  $m$  the response time is

$$T = \left\{ \begin{array}{ll} \frac{1}{x_2} \left\{ -\frac{1}{2} x_2^2 + m\pi - x_1 \right\} & \text{if } x_1 \geq m\pi + \frac{1}{2} x_2^2 \\ \frac{1}{x_2} \left\{ -\frac{1}{2} x_2^2 + (m-2)\pi - x_1 \right\} & \text{if } x_1 < m\pi + \frac{1}{2} x_2^2 \end{array} \right\} \quad (46)$$

Let  $F_0$  denote the fuel consumed by the fuel-optimal system. The fuel  $F_0$  is given by

$$F_0 = k|x_2| \quad (47)$$

and, of course,  $F_0$  represents the minimum fuel required to force  $(x_1, x_2)$  to  $(0, 0)$ .

From Eqs. (42) and (45) one finds

$$\lim_{|x_2| \rightarrow 0} T = \infty \quad (48)$$

$$\lim_{|x_2| \rightarrow 0} F_0 = 0 \quad (49)$$

The large response times required by the fuel-optimal system for small values of  $x_2$  are undesirable from an engineering point of view. There exist techniques for improving the time response of such a system with an increase in the amount of fuel required.

Such techniques have been reported in Ref. 8 and they can be used to improve the

response of the fuel-optimal system.

Another disadvantage of the fuel-optimal system and its engineering realization of Fig. 6 is that switching from  $u = 0$  to  $u = +1$  or  $-1$  occurs only at the  $\gamma_n$  curves. This means that a slight malfunction of the relays in Fig. 6 might cause the control to remain at  $u = 0$  and thus impair the time-response of the system, but not affect the consumed fuel. An engineering cure for the phenomenon is to use relays with some dead-zone or hysteresis so as to "widen" the  $\gamma_n$  curves in the plane so that the transition from "off" to "on" occurs in finite areas rather than on curves.

## 6. CONCLUSIONS

The time-optimal and the fuel-optimal control laws have been derived for the attitude control of a satellite. The necessary nonlinear controllers were designed and their operation explained.

## APPENDIX

### Proof of Theorem 1

We shall use the Maximum Principle (see Ref. 4) to prove Theorem 1. The time-optimal Hamiltonian for the system of Eq. (8) is

$$H = 1 + x_2(t)p_1(t) + u(t)p_2(t) \quad . \quad (49)$$

The minimum of H occurs at

$$u(t) = - \operatorname{sgn} \{p_2(t)\} \quad . \quad (50)$$

But

$$\dot{p}_1 = - \frac{\partial H}{\partial x_1(t)} = 0 \quad (51)$$

$$\dot{p}_2(t) = - \frac{\partial H}{\partial x_2(t)} = -p_1(t) \quad . \quad (52)$$

Let

$$p_1(0) = \pi_1 \quad ; \quad p_2(0) = \pi_2 \quad . \quad (53)$$

Then

$$p_2(t) = \pi_2 - \pi_1 t \quad . \quad (54)$$

Therefore

$$u(t) = - \operatorname{sgn} \{\pi_2 - \pi_1 t\} \quad . \quad (55)$$

Equation (55) means that only the four control sequences (see Definition 2) can be candidates for time-optimal control

$$\{+1\}, \{-1\}, \{+1, -1\}, \{-1, +1\} \quad . \quad (56)$$

We shall first prove that if  $(x_1, x_2) \in \gamma_{0+}$ , then  $u = +1$  is the time-optimal control, i. e. the sequence  $\{+1\}$  is time-optimal. Consider, in Fig. 7, the point  $A \in \gamma_{0+}$ . By definition, the control sequence  $\{+1\}$  transfers A to O along AO (i. e. along the  $\gamma_{0+}$  curve). From the remaining sequences of Eq. (56) only the sequence  $\{-1, +1\}$  can force

A to O along the trajectory ABCC'AO, provided the transition from -1 to +1 occurs at  $B \in \gamma_{-2}$ . But the time along ABCC'AO is greater than the time along AO (because AO is a portion of ABCC'AO), hence the sequence  $\{-1, +1\}$  is not time-optimal, and hence  $\{+1\}$  is time-optimal. Q. E. D. Using similar reasoning we can prove that if  $(x_1, x_2) \in \gamma_{0-}$ , then  $u = -1$  in the time-optimal control.

Now suppose the initial state  $(x_1, x_2) \in R_{0,1}$ . The only control sequences that can force  $(x_1, x_2)$  to  $(0, 0)$  are  $\{-1, +1\}$  and  $\{+1, -1\}$ . The sequence  $\{-1, +1\}$  is the time-optimal one; this follows from the arguments presented in Section 3 where the  $\gamma_1$  curve was defined (that is, the arguments following Definition 2 up to Proposition 3).

For all the other states the procedure is quite similar. First one finds the control sequences which force  $(x_1, x_2)$  to  $(0, 0)$  and then by direct computation one can prove all the statements of Theorem 1.

#### ACKNOWLEDGMENT

The author is indebted to Dr. Harold K. Knudsen of Lincoln Laboratory for the many stimulating discussions.

## REFERENCES

1. A. M. Hopkin, "A Phase Plane Approach to the Design of Saturating Servomechanisms," *Trans. AIEE*, 70 (1950), pp. 631-639.
2. D. C. McDonald, "Nonlinear Techniques for Improving Servo Performance," *Proc. National Electronics Conference*, 6 (1950), pp. 400-421.
3. I. Bogner, "An Investigation of the Switching Criteria for Higher-Order Contractor Servomechanisms," *Cook Research Labs Interim Report*, PR-16-9 (1953).
4. L. S. Pontryagin, et al, The Mathematical Theory of Optimal Processes (Interscience Publishers, J. Wiley and Sons, New York 1962).
5. M. Athans, "Minimum-Fuel Feedback Control Systems: Second Order Case," *IEEE Trans. on Applications and Industry*, 82 (March 1963), pp. 8-17.
6. I. Flügge-Lotz and H. Marbach, "The Optimal Control of Some Attitude Control Systems for Different Performance Criteria," *ASME Paper 62-JACC-6* (1962).
7. J. S. Meditch, "On Minimal Fuel Satellite Attitude Control," accepted for presentation at 1963 JACC.
8. M. Athans, "Fuel-Optimal Control of a Double Integral Plant with Response Time Constraints," accepted for publication in *Trans. IEEE* (1963).

## FIGURE CAPTIONS

- Fig. 1        The physical system.
- Fig. 2        The  $\gamma_n$  curves and the  $R_{n,n+1}$  regions.
- Fig. 3        The trajectories XZAA'O and XYO.
- Fig. 4        An engineering realization of the time-optimal control law provided by Theorem 1.
- Fig. 5        The  $\gamma_n$  curves ( $n = 0, \pm 2, \pm 4, \dots$ ). ABO and CDD'EFF'O are examples of fuel-optimal trajectories.
- Fig. 6        An engineering realization of the fuel-optimal control law provided by Theorem 2.
- Fig. 7        The trajectories which arise from different control sequences.

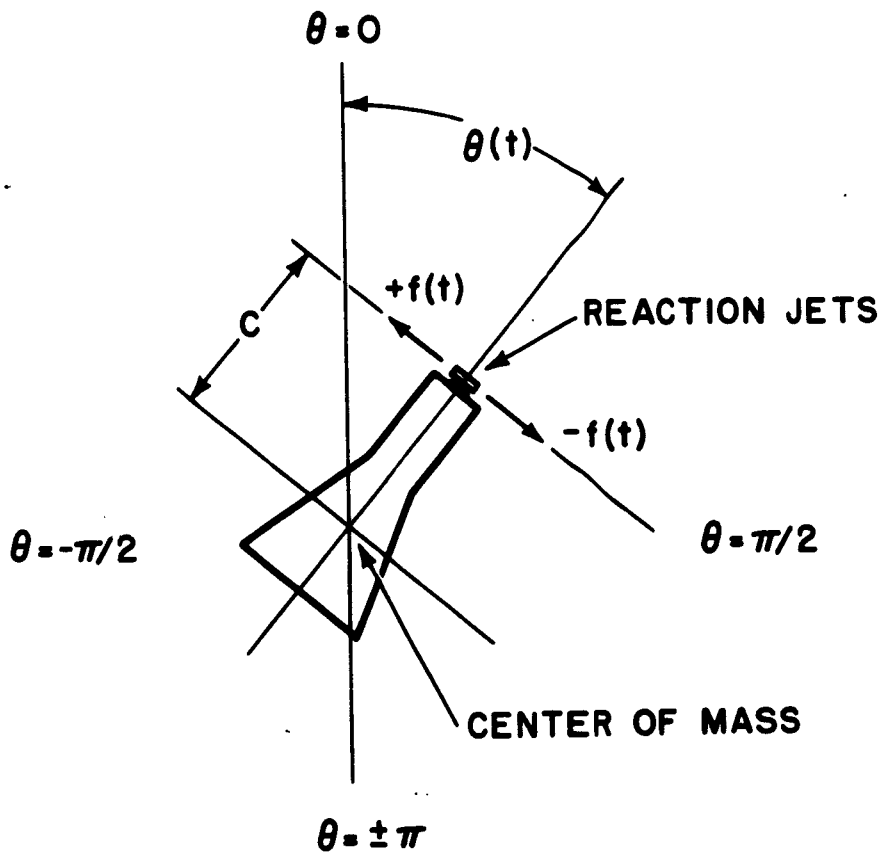

Fig. 1

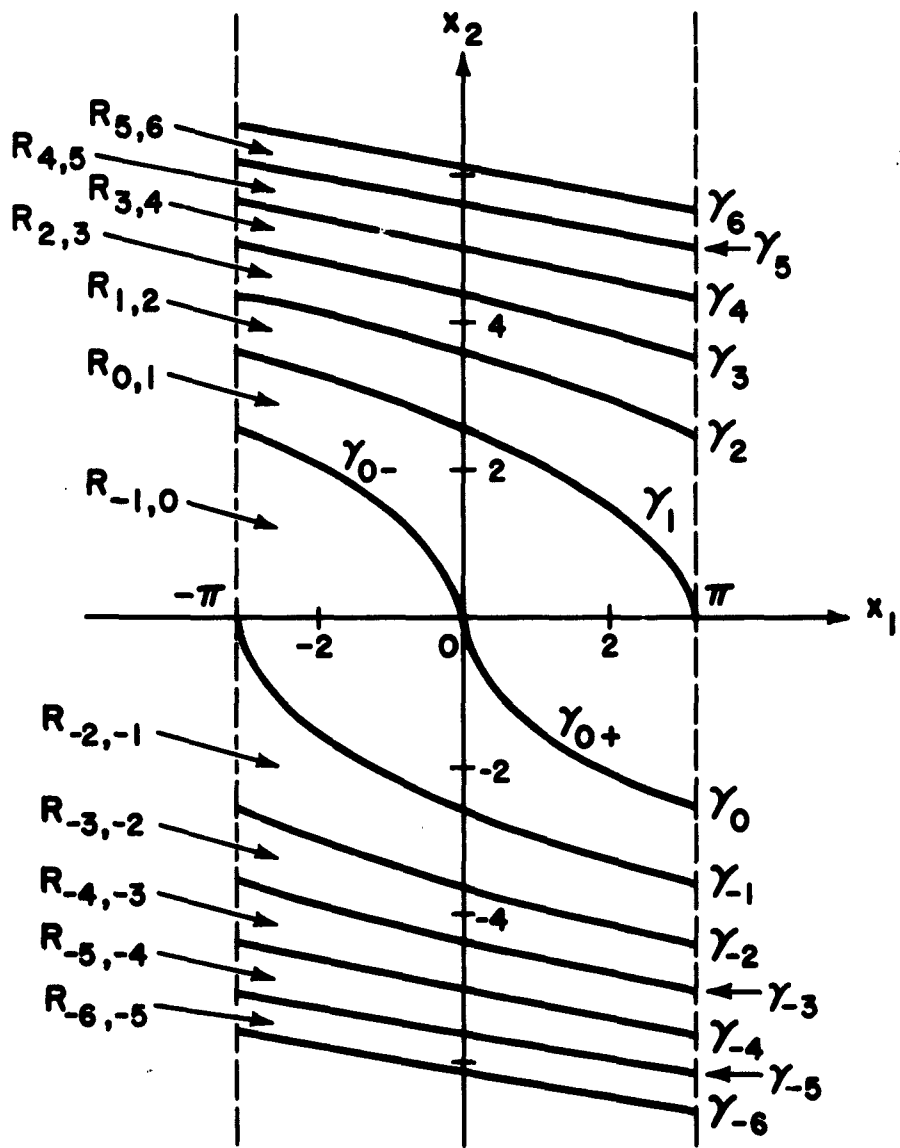

Fig. 2

3-22-4354

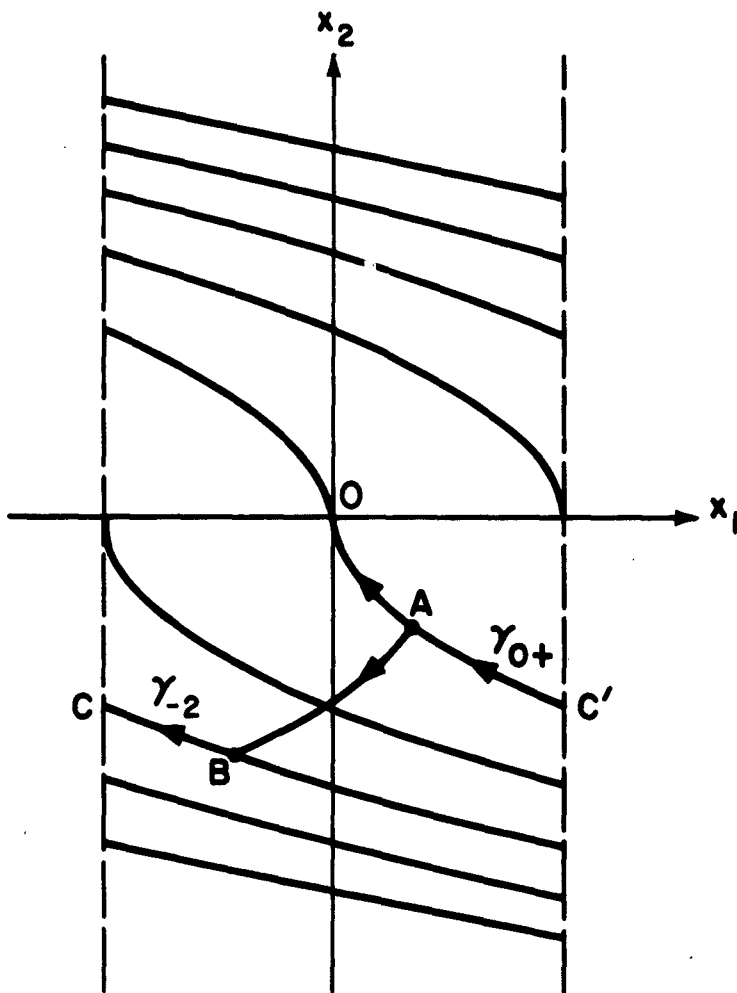

Fig. 3

3-22-4351

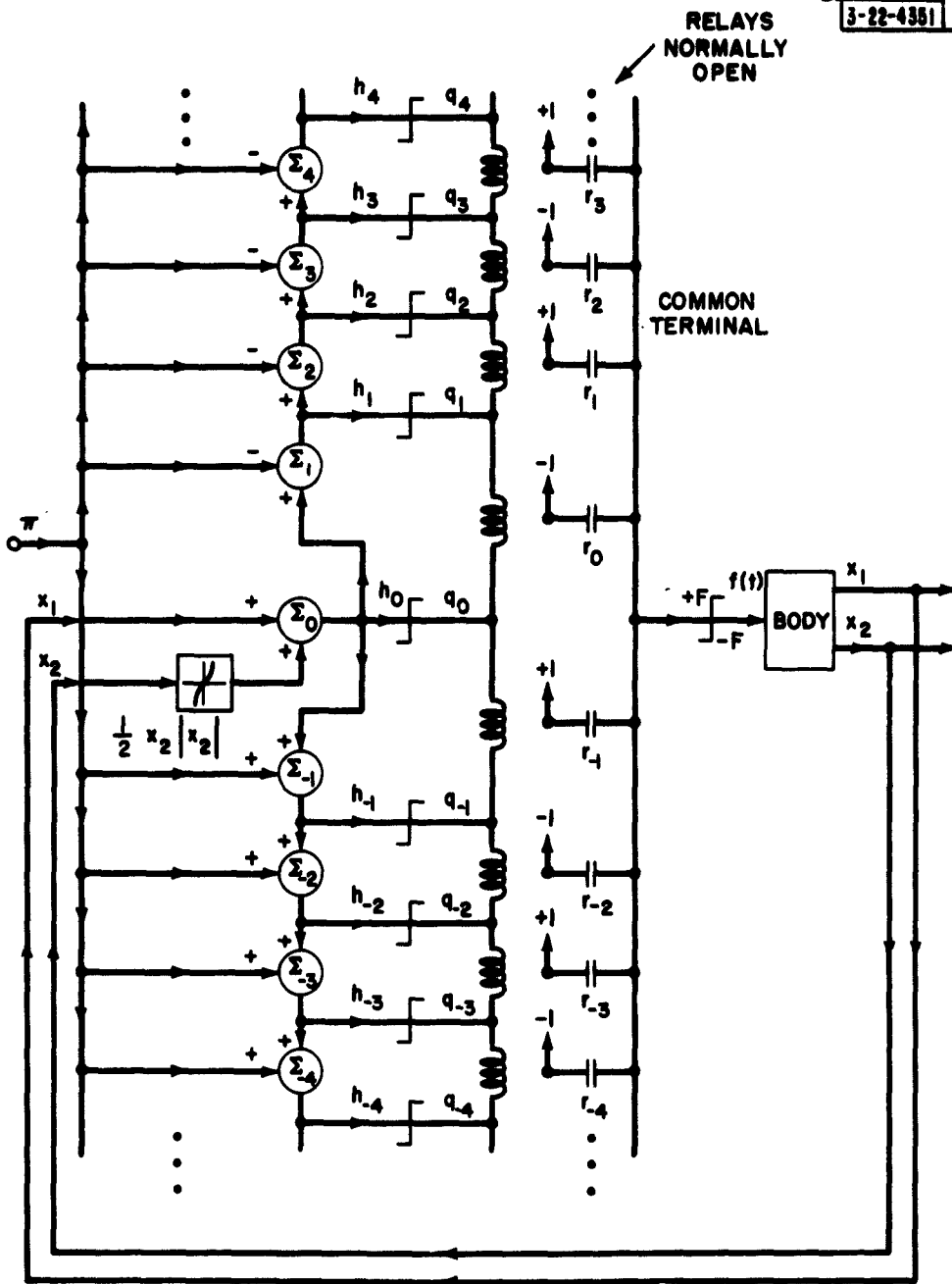

Fig. 4

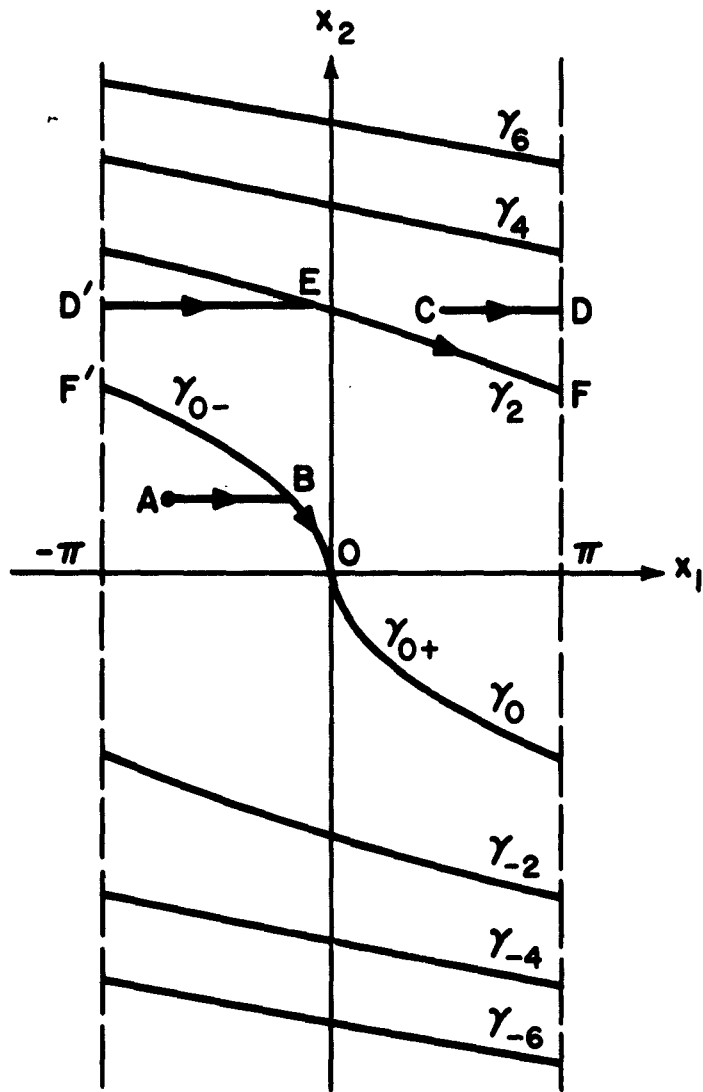

Fig. 5

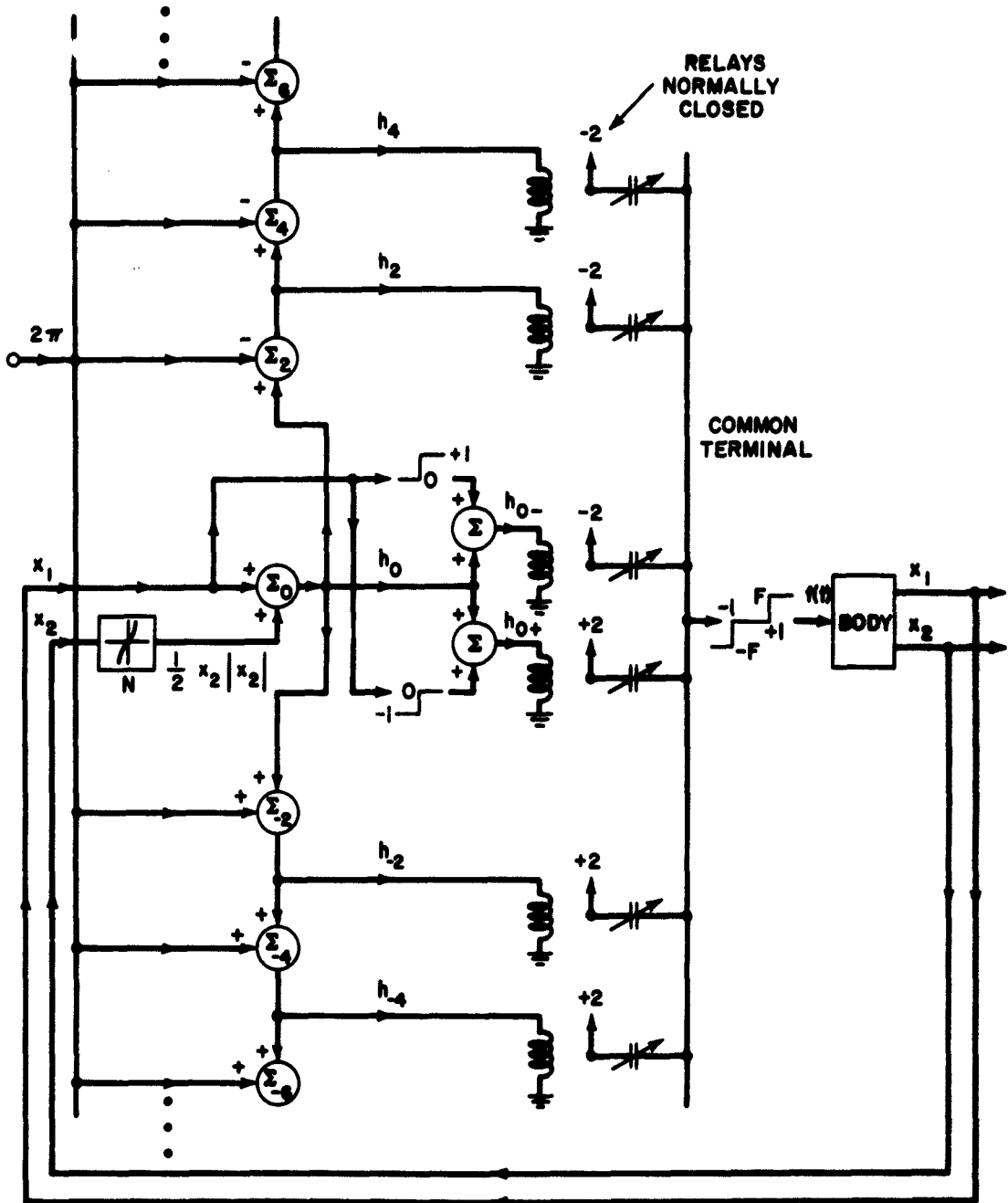

Fig. 6

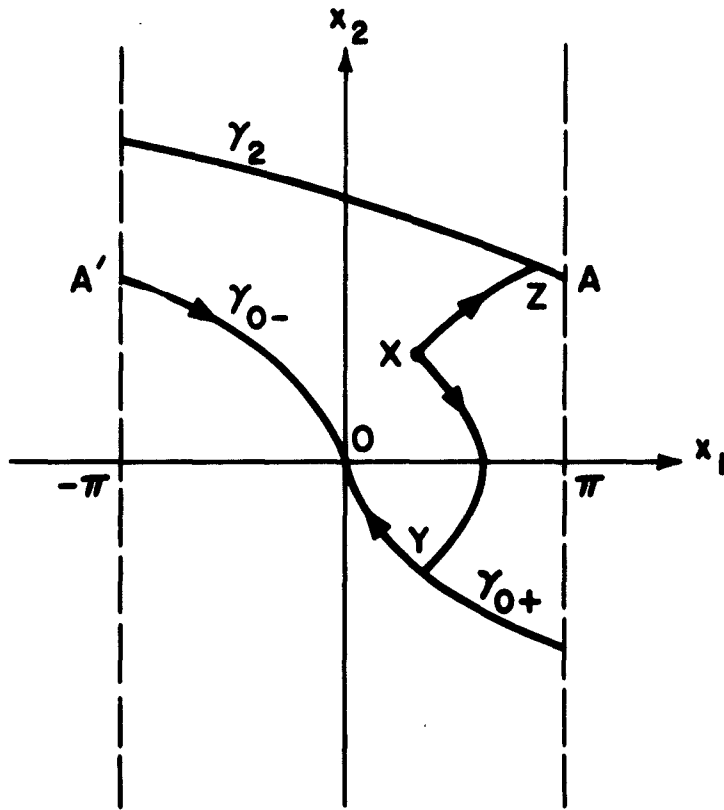

Fig. 7

**DISTRIBUTION LIST**

**Division 2**

**C. R. Wieser  
S. H. Dodd**

**Group 22**

**V. A. Nedzel  
J. F. Nolan  
W. I. Wells  
  
C. R. Arnold  
M. Athans (100)  
T. C. Bartee  
P. L. Falb  
A. Freed  
L. A. Gardner, Jr.  
A. A. Grometstein  
J. H. Halberstein  
L. Kleinrock  
H. K. Knudsen  
E. Korngold  
H. J. Kushner  
J. Lewis  
D. Sakrison  
M. Schneider  
F. C. Schweppe  
C. W. Uskavitch  
J. M. Winett  
P. Wood**

**Group 25**

**H. Sherman**

**Group 28**

**H. E. Melly  
A. J. Morency  
J. Slesers**

Dr. R. E. Kalman  
RIAS Inc.  
7212 Bellona Avenue  
Baltimore 12, Maryland

Professor C. A. Desoer  
Dept. of Electrical Engineering  
University of California  
Berkeley 4, California

Professor O. J. M. Smith  
Dept. of Electrical Engineering  
University of California  
Berkeley 4, California

Professor E. Polak  
Dept. of Electrical Engineering  
University of California  
Berkeley 4, California

Professor O. Elgerd  
Dept. of Electrical Engineering  
University of Florida  
Gainesville, Florida

Professor Y. C. Ho  
Computation Laboratory  
Harvard University  
Cambridge, Massachusetts

Dr. M. Masarovi  
Case Institute of Technology  
Cleveland 6, Ohio

Professor S. S. L. Chang  
Dept. of Electrical Engineering  
New York University  
New York, New York

Professor I. Flügge-Lotz  
Dept. of Engineering  
Stanford University  
Stanford, California

Dr. George Lendaris, Defense Systems Div.  
General Motors Corp.  
Santa Barbara, California

Dr. C. Harvey  
Minneapolis Honeywell Reg. Co.  
Minneapolis, Minnesota

Mr. Ernest Holzmann  
Rm. 116, Bldg. 3, General Electric Co.  
Electronics Lab., P. O. Box 1122  
Syracuse, New York

Professor R. Bach  
112 G. Northeastern University  
Huntington Avenue  
Boston, Massachusetts

Dr. M. Aoki  
Dept. of Engineering  
University of California  
Los Angeles, California

Dr. E. B. Lee  
Minneapolis Honeywell Reg. Co.  
Minneapolis, Minnesota

Professor George Newton  
Dept. of Electrical Engineering  
Massachusetts Institute of Technology  
Cambridge, Massachusetts

Professor James Eaton  
University of California  
Berkeley 4, California

Dr. Lucien Neustadt  
Aerospace Corporation  
El Segundo, California

Hq. ESD (Maj. S. Jeffery ESRC)  
L. G. Hanscom Field  
Bedford, Massachusetts

Hq. ESD (Lt. J. Egan)  
L. G. Hanscom Field  
Bedford, Massachusetts

Also distribute to NASA Distribution List.