

63-4-1

5 46 450



REPORT

ASD-TDR-63-369

61055-F

INVESTIGATION OF TECHNIQUES FOR CONTROL OF INTERFERENCE GENERATED BY SWITCHING DEVICES

Technical Documentary Report ASD-TDR-63-369
January 1963

Electronic Warfare and Communications Laboratory
Aeronautical Systems Division
Air Force Systems Command
Wright-Patterson Air Force Base, Ohio

Project No. 4357 Task No. 435712

(Prepared under Contract No. AF33(657)-7268 by
American Electronic Laboratories, Inc., Colmar, Pa.
E. Katz and F. Messner, Authors)

DDC
RECEIVED
JUN 20 1963
RESERVED
TISIA D

American
Electronic
Laboratories
COLMAR, PENNA.

CATALOGED BY DDC 407449

AS AD No. 407449



NOTICES

When Government drawings, specifications, or other data are used for any purpose other than in connection with a definitely related Government procurement operation, the United States Government thereby incurs no responsibility nor any obligation whatsoever; and the fact that the Government may have formulated, furnished, or in any way supplied the said drawings, specifications, or other data, is not to be regarded by implication or otherwise as in any manner licensing the holder or any other person or corporation, or conveying any rights or permission to manufacture, use, or sell any patented invention that may in any way be related thereto.

Qualified requesters may obtain copies of this report from the Armed Services Technical Information Agency, (ASTIA), Arlington Hall Station, Arlington 12, Virginia.

This report has been released to the Office of Technical Services, U.S. Department of Commerce, Washington 25, D.C., for sale to the general public.

Copies of this report should not be returned to the Aeronautical Systems Division unless return is required by security considerations, contractual obligations, or notice on a specific document.

FOREWORD

This report was prepared by American Electronic Laboratories Inc., Colmar, Pa. on Air Force Contract AF33(657)-7268 under Task No. 435712 of Project No. 4057. It presents analytical and laboratory test results of a one year study program on the "Investigation of techniques for control of interference generated by switching devices".

Technical direction and administration were provided by Messrs. C. R. Austin and H. Bartman of the Electromagnetic Environment Branch, ASD.

Principal AEL contributors to the studies were E. Katz and F. Messner. The program was under the general supervision of R. H. Sugarman, Laboratory manager.

This report is the Technical Documentary Report and it concludes the work on contract AF33(657)-7268. The contractor's report number is 61055-F.

ABSTRACT

The objective of this program was to investigate the basic characteristics of electronic circuitry, components, and design practices that contribute to the creation of interference in present and proposed switching devices, and to determine techniques required for effective reduction and control of this interference. Particular emphasis is placed on solid state devices, both as sources of interference and as suppression techniques.

In addition to presenting experimental data and new interference reduction concepts as developed under this program, this report provides a general dissertation on the generation and transmission of switching device interference and on techniques for suppression of this type of interference. Major coverage has been given to the area of filter techniques, including the development and comprehensive analysis of active filter networks. Use of passive suppressor elements to minimize undesired transients is considered, and a group of circuit techniques to protect against DC line transients is presented.

TABLE OF CONTENTS

<u>Section</u>		<u>Page</u>
I	INTRODUCTION	1
	A. General	1
II	TECHNICAL DISCUSSION	3
	A. Generation of Interference	3
	1. General	3
	2. Time-Frequency Relationships	3
	3. Pulse Spectrum	4
	4. Relationship Between Spectrum and Pulse Shape	4
	5. Incidental Interference	7
	6. System Considerations	8
	B. The Transmission of Interference	9
	1. General	9
	2. Conducted Coupling	9
	3. Radiation	9
	4. Line-to-Line Coupling	11
	C. Laboratory Investigations	11
	1. Objective	11
	2. Interference Generating Circuits	11
	3. Test Results	13
	D. Interference Suppression Techniques	27
	1. General	27
	2. Resistor Suppressor	27
	3. Non-Linear Resistive Elements	30
	4. Capacitors	30
	5. Resistance - Capacitance Suppressors	31
	6. Diode Suppressors	32
	7. Line Transient Protective Devices	35
	8. Transistorized Switch Control	42
	E. Filter Networks	43
	1. Passive Filters	43
	2. Active Filter Networks	43
	3. Negative Impedance Converter	44
III	CONCLUSIONS AND RECOMMENDATIONS	45
IV	BIBLIOGRAPHY	46
	Appendix I Operation of the Zener Diode as a Protective Element	I-1
	Appendix II Passive Filter Design Techniques	II-1

TABLE OF CONTENTS (CONT.)

<u>Section</u>	<u>Page</u>
Appendix III Investigation of Active Filter Networks	III-1
Appendix III-B High Frequency Calculation of E_o/E_i For Ripple Clipper Circuit	III-B-1
Appendix III-C Analysis of Three Transistor Active Filter Network	III-C-1
Appendix III-D Analysis of Five Transistor Active Network	III-D-1
Appendix IV Negative Impedance Converters	IV-1

LIST OF ILLUSTRATIONS

<u>Figure</u>	<u>Title</u>	<u>Page</u>
1	Pulse Spectra	5
2	Spectra of Four Pulses. All Pulses Have Equal Width at Half Amplitude, and Equal Maximum Amplitude	6
3	Sketch of Line, Antenna and Ground Plane Used for Measurements	12
4	Crystal-Locked Blocking Oscillator	12
5	Schematic Diagram of Base-Triggered Bistable Multivibrator	14
6	Schematic Diagram Coil Driver	15
7	Radiated Interference Levels From Line Carrying Output of Blocking Oscillator	16
8	Decoupling Networks Used with Blocking Oscillator and Bistable Multivibrator	18
9	Conducted Interference Level for Blocking Oscillator with Decoupling Filters of Figure 8	19
10	Radiated Levels from Power Supply Lines for Blocking Oscillator with Decoupling Filters of Figure 8	20
11	Conducted Interference Level of Bistable Multivibrator (Base Triggered)	22
12	Conducted Interference Levels of Coil Driver Circuit	23
13	Adjacent Lines for Pickup Measurements	26
14	Equivalent Circuits	26
15	Resistors and Capacitors as Suppression Devices.	29
16	Diode Suppressors	33
17	Littelfuse Transistor Protector	36
18	Electronic Crowbar for Protection of Loads Against Over-Voltage	36
19	Gate Turn Off Controlled Switch Limiter	39
20	Emitter Follower Limiter	39
21	Transistorized Switch Control	39

I. INTRODUCTION

A. GENERAL

Creation of transients by switching devices is an old interference problem for which varying degrees of success have been achieved in its solution. The advent of widespread use of solid state devices has added to the problem. These devices generate transients and are themselves very susceptible to transients. For example, switching transients may look like a "bit" of information to digital computers. This can result in very adverse effects on communications and guidance control equipments employing digital computer circuitry.

The objective of this program is to investigate the basic characteristics of electronic circuitry, components, and design practices that contribute to the creation of interference in present and proposed switching devices, and to determine techniques required for effective reduction and control of this interference in the electronic equipment design stage.

The program, as discussed in this report, consisted essentially of four major task areas.

(1) National Questionnaire Survey - Comprehensive questionnaire submitted to military and industrial organizations concerned with aircraft, missile, and computer systems to determine the nature and extent of interference problems produced by switching devices. Results have been submitted to ASD and have been used to guide development work under this program.

(2) Theoretical and Experimental Analysis - Theoretical analysis on the generation and transmission of switching or impulse type interference combined with laboratory measurements on typical test circuits and lines to compare actual interference parameters with those theoretically predicted.

(3) Interference Reduction Techniques - Investigation of conventional components and circuit configurations utilized in suppression of switching interference with analysis of design parameters, applications, and limitations.

Manuscript released by the author (20 May 1963) for publication as an ASD Technical Documentary Report.

(4) New Techniques Development - Application of transistors in the design and development of "active" filter networks for replacement of bulky LC filters in suppression of low frequency interference on DC power lines.

II. TECHNICAL DISCUSSION

A. GENERATION OF INTERFERENCE

1. General

Any switching system, or digital device, depends on two signal levels for its operation. Generation of these levels is equivalent to the generation of a series of rectangular pulses. As long as the energy contained in these pulses is confined to the desired transmission paths and receivers, there is no problem. These signals are prone to appear in circuits where they are not desired. It is at these points that they represent interference.

Where the interference is caused by a desired signal in another circuit, it is rare that the interference can be completely removed without compromising the desired function. In some cases, the interference is caused, not so much by a desired signal, but as a side effect of some desired circuit function. As an example, the transients generated when an inductive circuit is opened are desired in either the operating circuit, or in any circuit these transients interfere with. Much of the transient can be eliminated with beneficial results to these circuits.

One of the areas in which switching circuits cause interference problems is in electronic equipment used for communications and navigation. This may occur in spite of the fact that the interfering and interfered signals seemingly occupy distinctly different frequencies. To understand this, a knowledge of the frequency spectrum of a time waveform is necessary.

2. Time-Frequency Relationships

Any periodic time waveform may be represented by a series of sinusoidal waveforms of appropriate amplitudes and phases. The restrictions on this transformation are largely that these time functions must be single valued, and that they have only a finite number of discontinuities within the time period. The technique usually employed for this transformation is the Fourier series.

By means of either the LaPlace or Fourier transform the relationship between time function and frequency domain can be extended to non-recurrent time phenomena. The utility of this relationship lies in a correlation between the spectrum of a non-recurrent waveform and the same waveform occurring on a periodic basis. The spectrum of the non-recurrent waveform is the envelope of the spectrum of the periodic function.

3. Pulse Spectrum

A rectangular pulse thus has a spectrum related to $\frac{\sin x}{x}$ (see Figure 1a). The crossover points are related to the duration of the pulse, and occur at frequencies $\omega = \frac{n}{T}$, where T is the pulse duration, and n assumes integral values. The major portion of the energy is contained in that portion of the spectrum between the first crossover points.

It may be seen that as the pulse duration decreases the distance between the first crossover point widens and as the pulse duration increases the distance between the first crossover points decreases. Similarly, as the pulse magnitude increases, the magnitude of the spectrum increases.

The spectrum of the single pulse forms the envelope for the spectral components of the repetitive pulse. Thus, we would find line components at frequencies which are integral multiples of the repetition frequency (Figure 1b). As the repetition frequency increases, the spectral components are more widely spaced, (Figure 1c) and as the repetition frequency decreases, they are more closely spaced, approaching the spectrum of a single pulse.

4. Relationship Between Spectrum and Pulse Shape

Increases in the rise time of the rectangular pulse have their major effect beyond the first crossover frequencies. Thus, changing the rectangular pulse to a cosine pulse, a cosine-squared pulse, or a gaussian pulse will affect the tails of the spectral distribution much more than the area under the major lobe (Figure 2).

This last point is readily justified by an examination of two time functions. The first is a step function, a time function translating from zero to some finite value at zero time; the second is a ramp function,

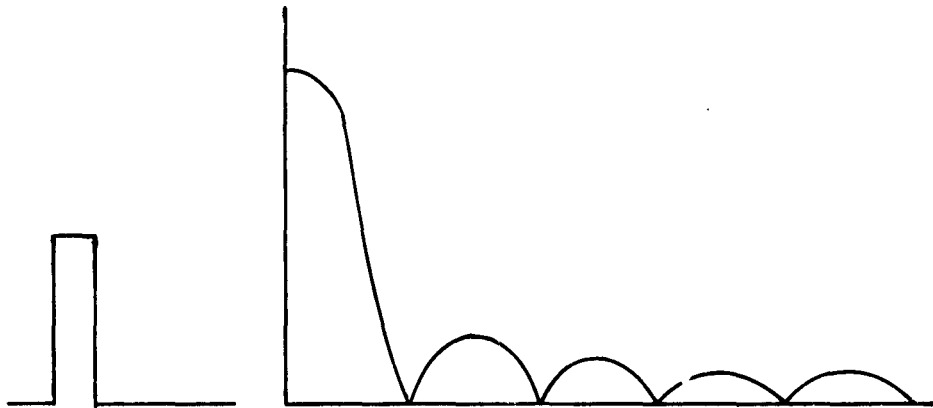

1 (a) Spectrum of Single Rectangular Pulse

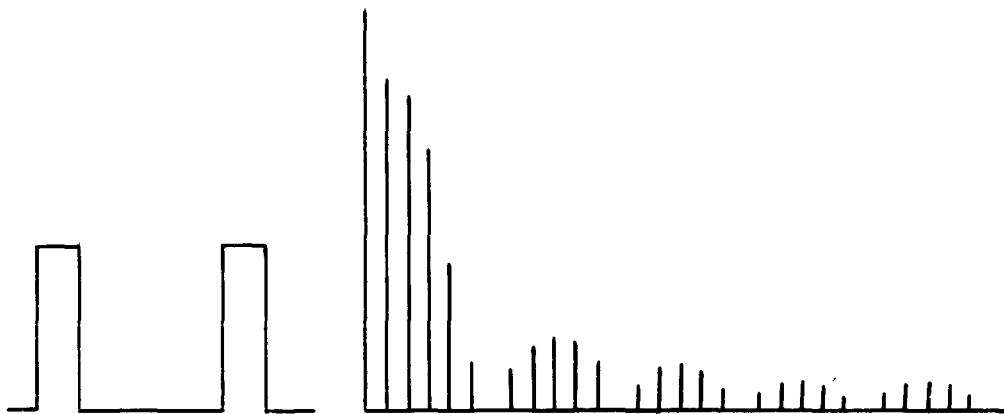

1 (b) Spectrum of Pulse of Same Width at Some P.R.F. Duty Factor = .125

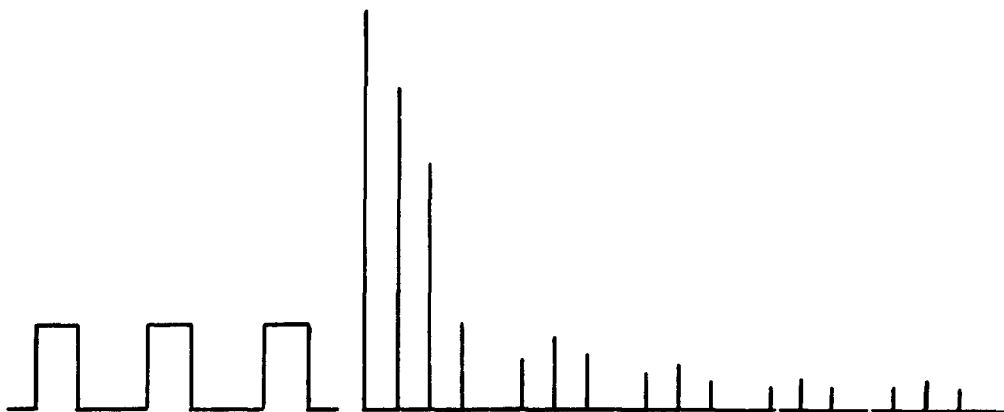

1 (c) Spectrum of Pulse of Same Width. 25% Duty Factor

Figure 1. Pulse Spectra

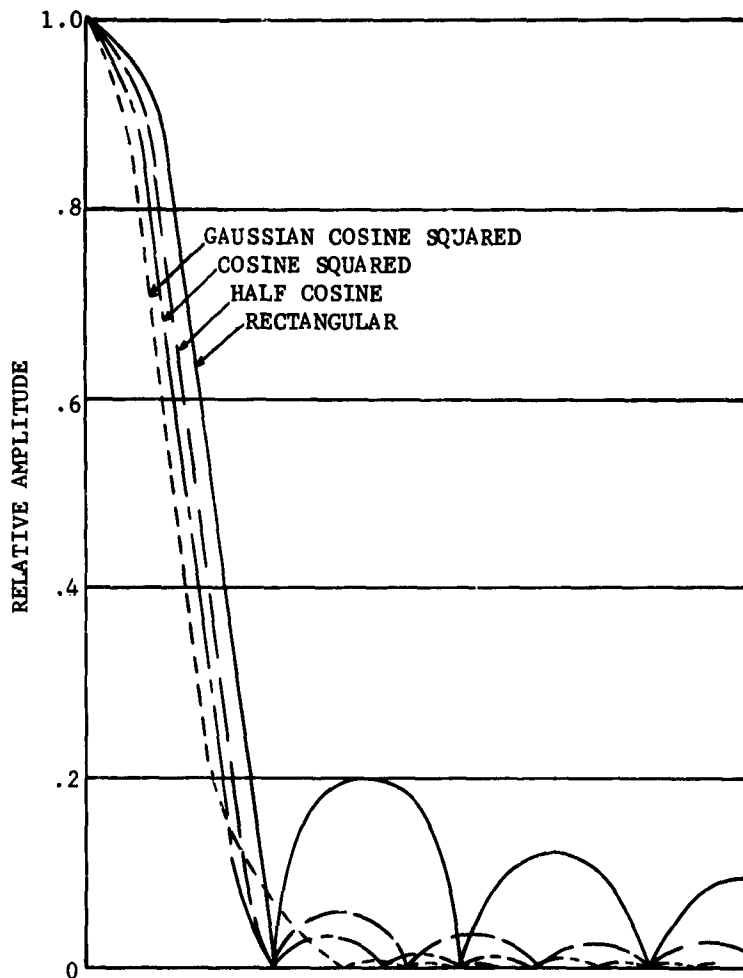

Figure 2. Spectra of Four Pulses. All Pulses Have Equal Width at Half Amplitude, and Equal Maximum Amplitude.

a time function increasing linearly in value with increasing time. The step function has a spectrum proportional to $\frac{1}{\omega}$, while the ramp has a spectrum proportional to $\frac{1}{\omega^2}$. The major differences in values of spectral components occur at the higher frequencies.

It has been stated that the crossover frequencies of the spectrum for a rectangular pulse are determined by the pulse duration, and that the spectral components occur at multiples of the repetition frequency. The points of zero crossing, then, are a function of the duty cycle of the pulse. Thus, if the pulse has a 10% duty cycle, the first zero crossing will occur at the 10th harmonic, the second zero crossing at the 20th harmonic, and the n^{th} zero crossing at the $10 n^{\text{th}}$ harmonic. Similarly, if the pulse has a 50% duty cycle, the first zero crossing will occur at the second harmonic, and the n^{th} zero amplitude harmonic will be the $2 n^{\text{th}}$ harmonic. Thus, higher frequency components may be minimized by utilizing the longest possible rise and fall times and the lowest repetition frequencies, and by making the duty cycle as close to 50% as possible.

It is in this manner that a waveform required for the operation of a system, or portion of a system, may generate frequencies which are capable of causing problems when they appear elsewhere in the system, or in other systems operating in proximity. With a knowledge of the waveform duration, magnitude, and repetition frequency, the potential interference points may be pinpointed, and with further knowledge of the means of transmission, a comparative estimate of desired and undesired signals reached. Reduction of the interference level cannot be achieved, by operation on the source, without compromise of the desired function.

5. Incidental Interference

It was stated earlier that transient interference might be incidental to a particular operation, rather than a necessary concomitant of it. As an example, consider the case of an inductive circuit switched on and off. When power is supplied to a series R-L circuit, a portion is dissipated in the resistance, but another portion is stored in the magnetic field about the inductance. At the time the circuit is interrupted, this stored

field will act to maintain the current flow through the inductor. If no path is provided for this current, the voltage in the branch will rise to whatever level is necessary to cause arcing, thus providing a path. The stored energy will then be dissipated in this loop. The breakdown voltage may be as high as a few hundred volts, and occasionally may rise to a kilovolt. In addition to the high voltage level which may be encountered, the voltage waveform across the arcing contacts may appear as a sawtooth, rising to the breakdown voltage necessary to cause arcing, dropping to a relatively low voltage under breakdown, and rising again, when the arcing stops momentarily. As the stored energy is dissipated, these breakdowns are of shorter duration and more widely spaced.

This source of interference can usually be minimized with little compromise to the intended operation by providing a shunt path consisting of a resistance, a diode, a resistance and diode in series, or a resistance and capacitance in series. This discharge path will limit the maximum voltage which may be built up during the discharge time. The price paid for this is the cost of the added component and an increase in the discharge time constant of the circuit. As a bonus, since maximum voltage levels are controlled, the probability of arcing is made much less, and the stress applied to the circuit components is reduced, improving the reliability, or life expectancy, of the circuit.

6. System Considerations

Since careful consideration should be given to the compromises involved in trading performance for interference minimization, it is important that this be done in the initial systems planning. Thus, it is probable that minimum rise times as well as maximum rise times should be specified, that minimum pulse durations as well as maximum durations for system pulses be controlled and careful consideration be given to a choice of pulse repetition frequencies. In general, for a large system, the system planner is the person with the requisite knowledge of the overall requirements to set these specifications.

B. THE TRANSMISSION OF INTERFERENCE

1. General

The term interference has been applied here to an undesired signal appearing at the receiver. Implicit in this statement is the result consisting of a false response to a desired stimulus when interference occurs. Up to this point, the interfering signal has been assumed to appear in the transmission channel. A closer examination of the possible means of access to the receiver follows.

2. Conducted Coupling

One means of interference transmission is through conducted coupling. This term is usually applied when interference results from the transmission of several signals through a common impedance such as a ground line, a decoupling resistor, or power leads. A second means of interference transmission is through radiation; the coupling of electromagnetic and electrostatic fields.

Reduction of conducted coupling is best achieved through reduction of the common impedance at all frequencies of interest. Where the impedance is that of a power supply, use of a regulator may be sufficient to reduce the source impedance. When high frequency components are involved, it is usually necessary to consider not only the source impedance, but the line impedance, in terms of inductance and capacitance per unit length, as well as resistance of this line. As the common impedance is reduced, the voltage drop across it must also be reduced proportionately.

Line impedance may be reduced by using larger wires more closely spaced. Use of the larger wire will simultaneously reduce both inductance and resistance per unit length of line; reducing the spacing between wires of a line serves to reduce the inductance per unit length while increasing the capacitance per unit length.

3. Radiation

Calculation of the radiated magnetic field from a wire shows the presence of two terms, one referred to as the radiation component, the second called the induction component. When dealing with radio frequency interference, it is the near field region which is of interest, and in

this region, the radiation field component may usually be neglected. At distances less than $1/6$ wavelength, the induction field alone will provide reasonable solutions. In this region, the induction term differs only slightly from the results found by application of Amperes Law. The intensity of the electric field may be found by a direct integration of the curl of the magnetic field with respect to time.

Reduction of electromagnetic field is difficult to accomplish through the use of shielding. Since the voltage induced by a changing magnetic field is proportional to the area of the loop cut by the magnetic field, the use of twisted pair lines, which keep both wires subject to the same field and minimizes the effective loop area, is recommended. Since the intensity of a magnetic field varies inversely as the square of the distance from the source, it is important to space low level signal leads as far as possible from lines causing interference. In general, these will be lines carrying high currents, or high voltage fast rise-time pulses.

Placement of the leads is also important since orthogonal crossings should reduce electromagnetic coupling to zero. A random lead pattern is usually useful in reducing this form of coupling between lines, since it reduces the effective parallel line lengths, and maximizes the effective spacings.

Reduction of electrostatic coupling between lines may be achieved through the use of large distances between wires, through the use of grounded shields, by the use of filtered leads, and by addition of bypass capacitors from each lead to ground. The addition of bypass capacitors from each line to ground reduces the impedance across which a voltage may be developed. Grounded shields provide a localized ground which is relatively stable with respect to the wires contained, and should maintain zero electric field on the inner surface. In this regard, it should be used as a shield only, and not utilized as a return path for the signal. Where the shield is used as a return path for the signal, it is possible for the shielding effectiveness to be reduced.

4. Line-to-Line Coupling

Coupling between closely spaced lines may take the form of capacitive or inductive coupling. The former is due to the capacitive effect between wires of the adjacent lines, the latter due to the magnetic induction present. Since the inductances for the line configurations are small, the inductive admittances are low compared to the capacitive admittances involved, and the prevailing coupling mode appears largely capacitive in nature. An estimate of the voltage transfer between lines may be based on the capacitive voltage divider thus formed.

C. LABORATORY INVESTIGATIONS

1. Objective

The basic purpose of laboratory investigations conducted as part of this program was to obtain laboratory data which might be correlated with analysis. With this objective in mind, a group of experiments were designed to provide data on conducted and radiated interference levels.

Interference sources or test units were operated with adjustable lines, first between power supply and test unit, and then between test unit and load. Conducted and radiated interference levels were measured as a function of line spacing, and the effect of filters and decoupling networks tested in the power supply leads.

Some measurements of line-to-line coupling were made with a proximate wire pair. Coupled interference levels were measured as a function of wire to wire spacing, and line to line spacing. Figure 3 is a sketch of the line, antenna ground plane relationships.

2. Interference Generating Circuits

Interference generating circuits consisted of a blocking oscillator, a bistable multivibrator, and a coil-driven circuit. The blocking oscillator circuit was intended to have a 5% duty cycle and operated at a 1 Mc/s rate. Difficulties with repetition rate stability made measurements of higher order harmonic components difficult, and dictated use of a crystal locked blocking oscillator. The schematic circuit of this unit is shown in Figure 4. The output pulse was close to 50 nanoseconds wide,

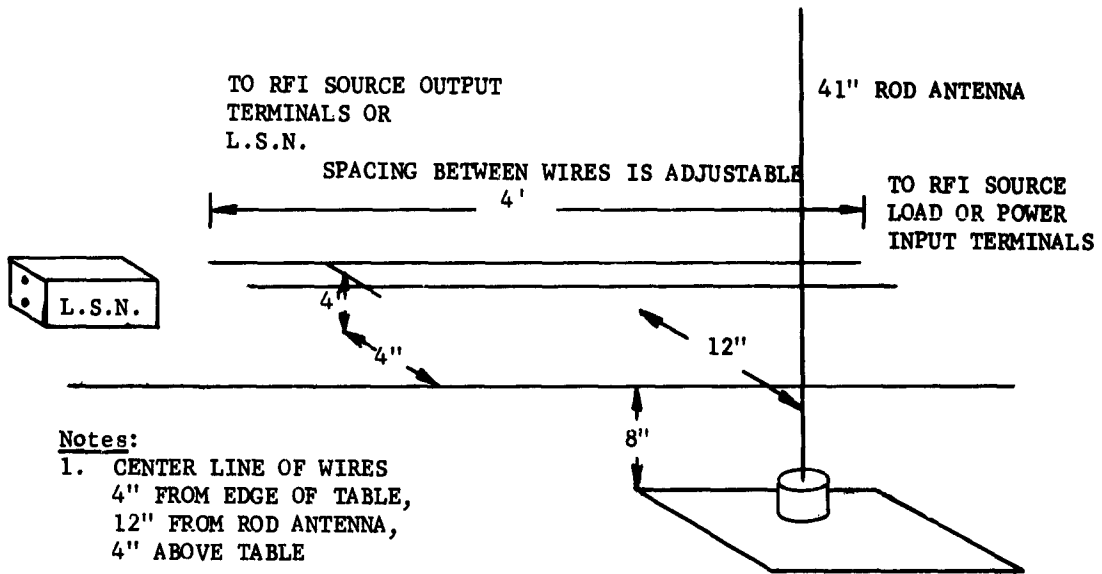

Notes:

1. CENTER LINE OF WIRES
4" FROM EDGE OF TABLE,
12" FROM ROD ANTENNA,
4" ABOVE TABLE
2. 12" x 12" PLATE 8" BELOW SURFACE
OF TABLE
3. ANTENNA POSITIONED FOR MAXIMUM READING

Figure 3. Sketch of Line, Antenna and Ground Plane Used for Measurements.

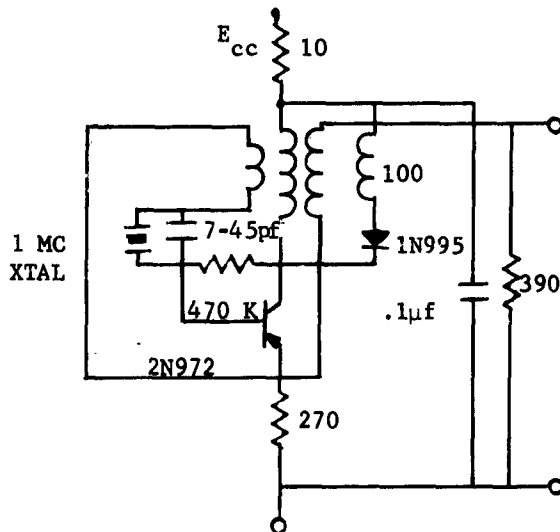

Figure 4. Crystal-Locked Blocking Oscillator.

measured at the 50% amplitude points, while rise and fall times were of the order of 15 nanoseconds.

The bistable multivibrator circuit originally built for these tests was a collector triggered circuit. When it was discovered that trigger signal, with power off, resulted in conducted interference levels only several db lower than interference levels with power, the circuit was modified to the base triggered circuit shown in figure 5.

The coil driver circuit tested was considered of interest since it was capable of switching currents of a few hundred milliamperes. It also offered the possibility of switching loads made intentionally reactive. A schematic circuit diagram is shown in figure 6.

3. Test Results

a. Blocking Oscillator

A four-foot length of line was set up in the screen room for measuring. The output of the blocking oscillator drove the line, with line spacings of $1/4''$, $1/2''$, and $1''$. Differences between results for various line spacings were small, as were differences for various loads with a given line spacing. These variations of the order of 2 db below 10 Mc/s, with maximum differences observed in the range of 6 to 8 db, are illustrated in figure 7. The poorest VSWR mismatch was about 2:2. The resulting standing wave ratio would result in a maximum change in voltage level along the line of 6.8 db. Since the standing wave ratio should have negligible effects until line length becomes greater than several per cent of the wavelength, it is reasonable to expect that these differences show up only above 10 Mc/s.

Based on a 7-volt amplitude of the pulse and 5% duty cycle, the peak amplitude expected for the fundamental radiated component was about 111 db above $1 \mu\text{v}/\text{Mc}$. This compares to a measured value of about 113 db.

Calculations for both rectangular and cosine pulses of 50 nanoseconds width show spectra going to zero at 20 Mc/s. The plot of calculated levels for a cosine shaped pulse is shown for comparison in figure 7. The observed data had a pronounced minimum in the neighborhood of 17 Mc/s. Since a variation of 5 nanoseconds in the pulse width could make a

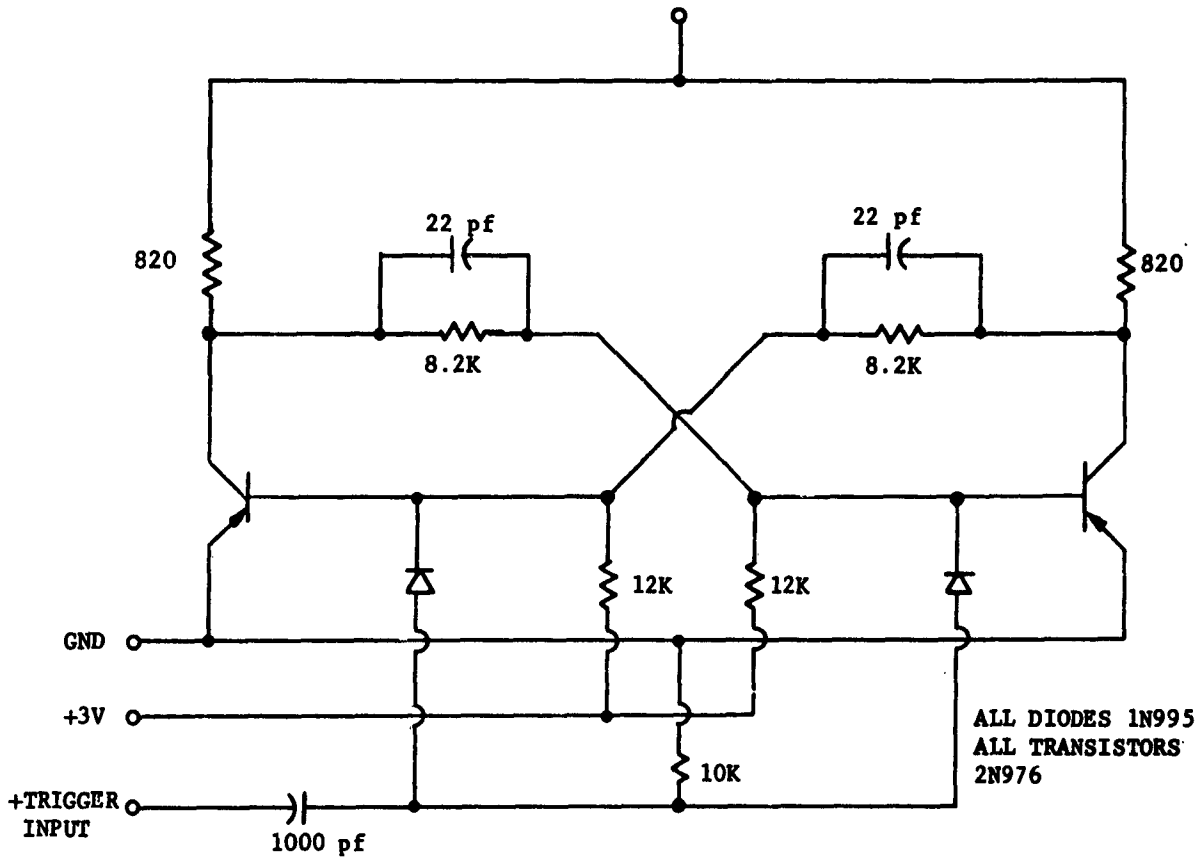

Figure 5. Schematic Diagram of Base-Triggered Bistable Multivibrator

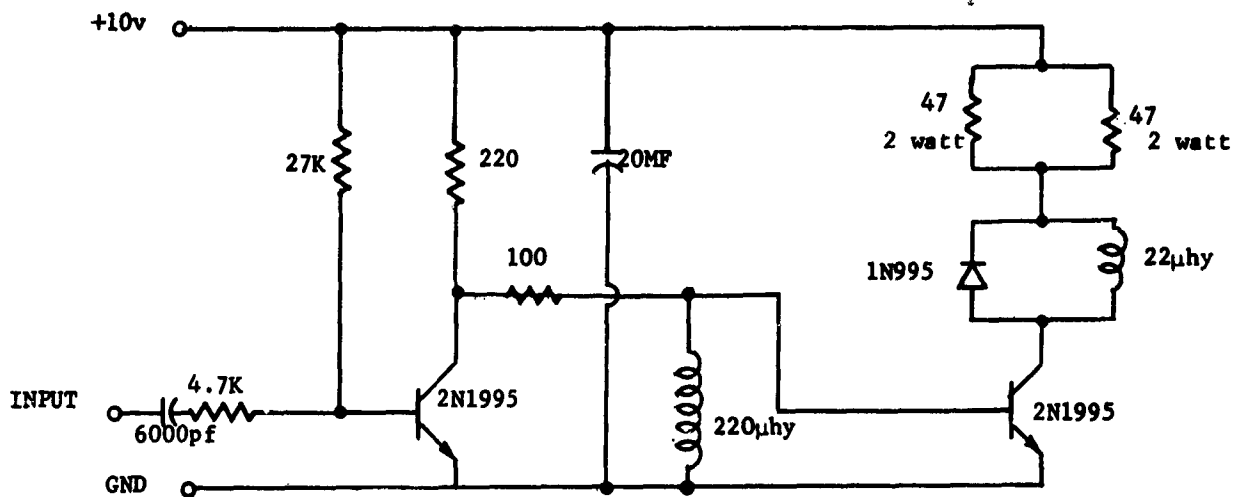

Figure 6. Schematic Diagram Coil Driver

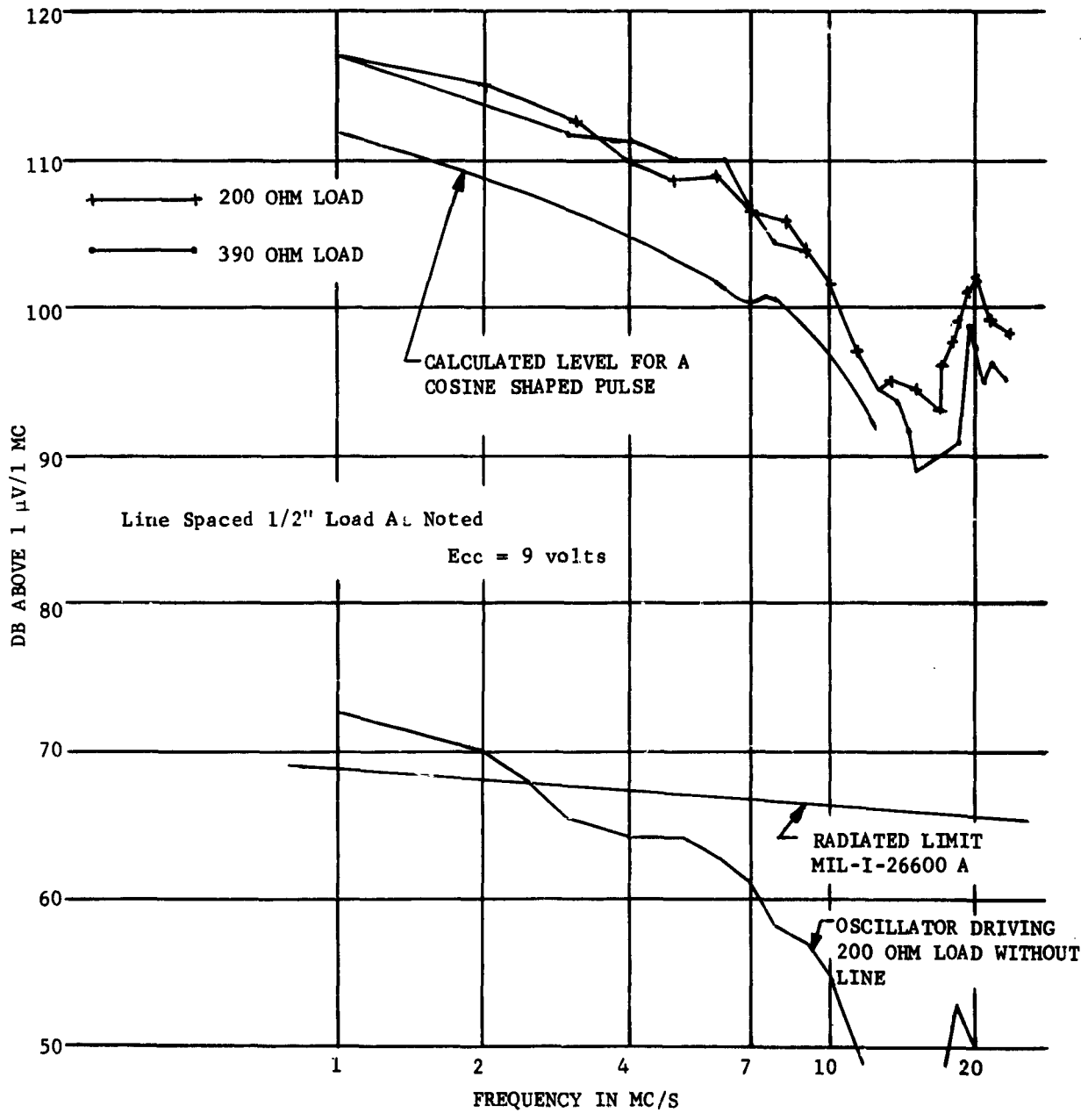

Figure 7. Radiated Interference Levels from Line Carrying Output of Blocking Oscillator.

difference of over 2 Mc/s in the position of the calculated null point, this was not considered a serious error. Such an error could easily have resulted if the oscilloscope probe used when measuring pulse duration had a loading effect different than that of the line and load driven.

Measurements of conducted interference levels on the power supply lines to the blocking oscillator showed changes of less than 5 db for variations in line spacing. With various decoupling filters, illustrated in figure 8, installed at the blocking oscillator, conducted and radiated measurements were made. The results are shown in figures 9 and 10. As may be seen, the presence of a series impedance, as in the filters of figures 8a, b, and d, is helpful in reducing the conducted levels. The changes in radiated levels for the decoupling networks of figures 8b, c, and d do not follow completely the changes in conducted levels. No reason has been determined for this. All are below the radiated level with the network of figure 8a.

Parasitic resonances of filter elements were observed to cause dips in the responses. Thus, a self-resonance of a .1 μ f ceramic capacitor caused a dip in the 4 to 6 Mc/s region. Use of a feedthrough capacitor eliminated both the self-resonance and the resulting dip. Grounding of the case was observed to make marked differences in the conducted levels, probably due to the ground plane carrying interference components around metering circuit.

b. Bistable Multivibrator

The bistable multivibrator was considered of interest for test since it is rather widely applied in digital and logic systems. The transistors switch between cutoff and saturation with each trigger pulse, with one transistor on and one transistor off during each resulting half cycle. For matched transistors, the net change in supply current should appear as a series of transition spikes at the trigger rate. The presence of spectral components at .5 Mc/s intervals is believed due to differences in the saturation currents of the two transistors, and the resulting asymmetry in the current waveform.

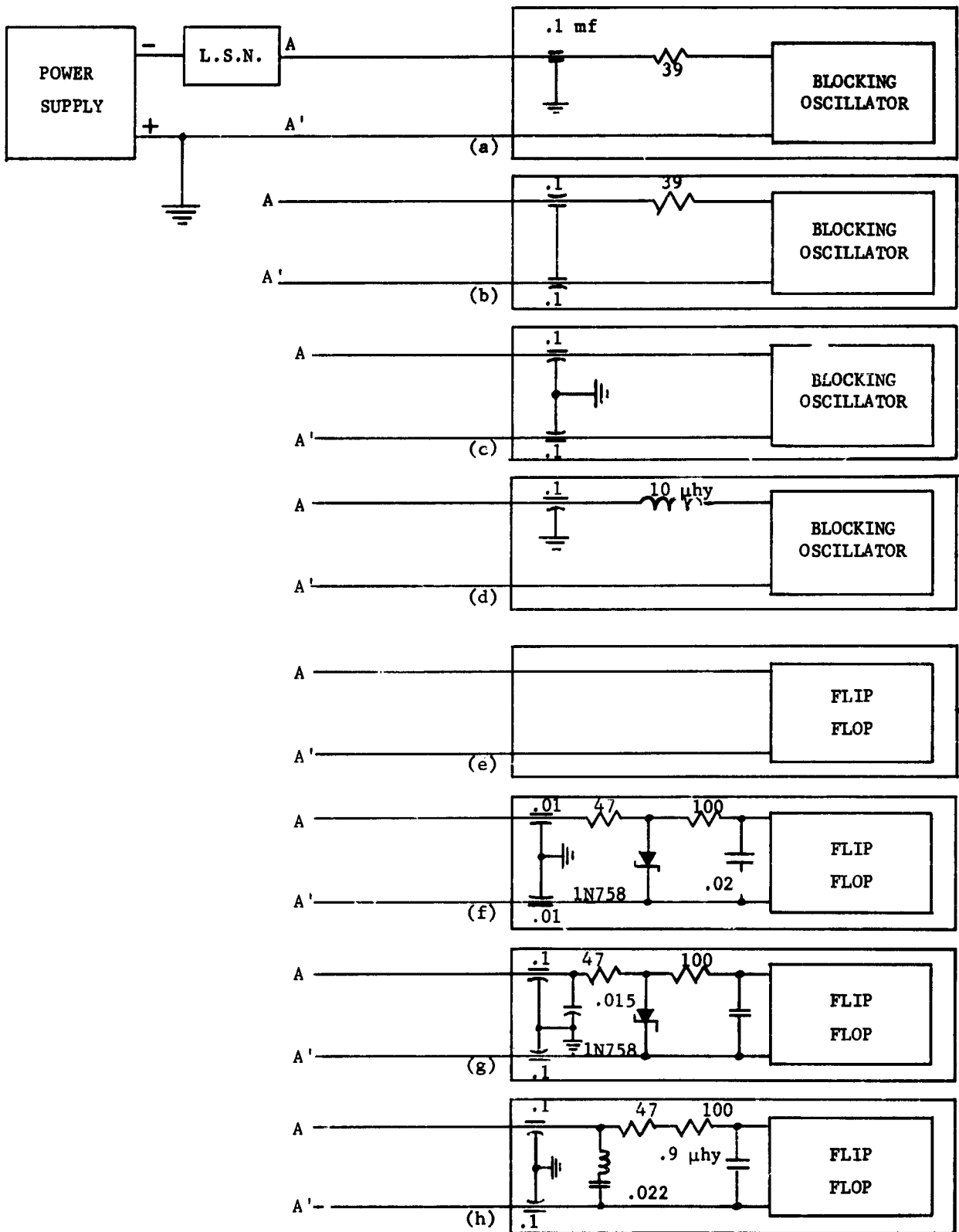

Figure 8. Decoupling Networks Used with Blocking Oscillator and Bistable Multivibrator.

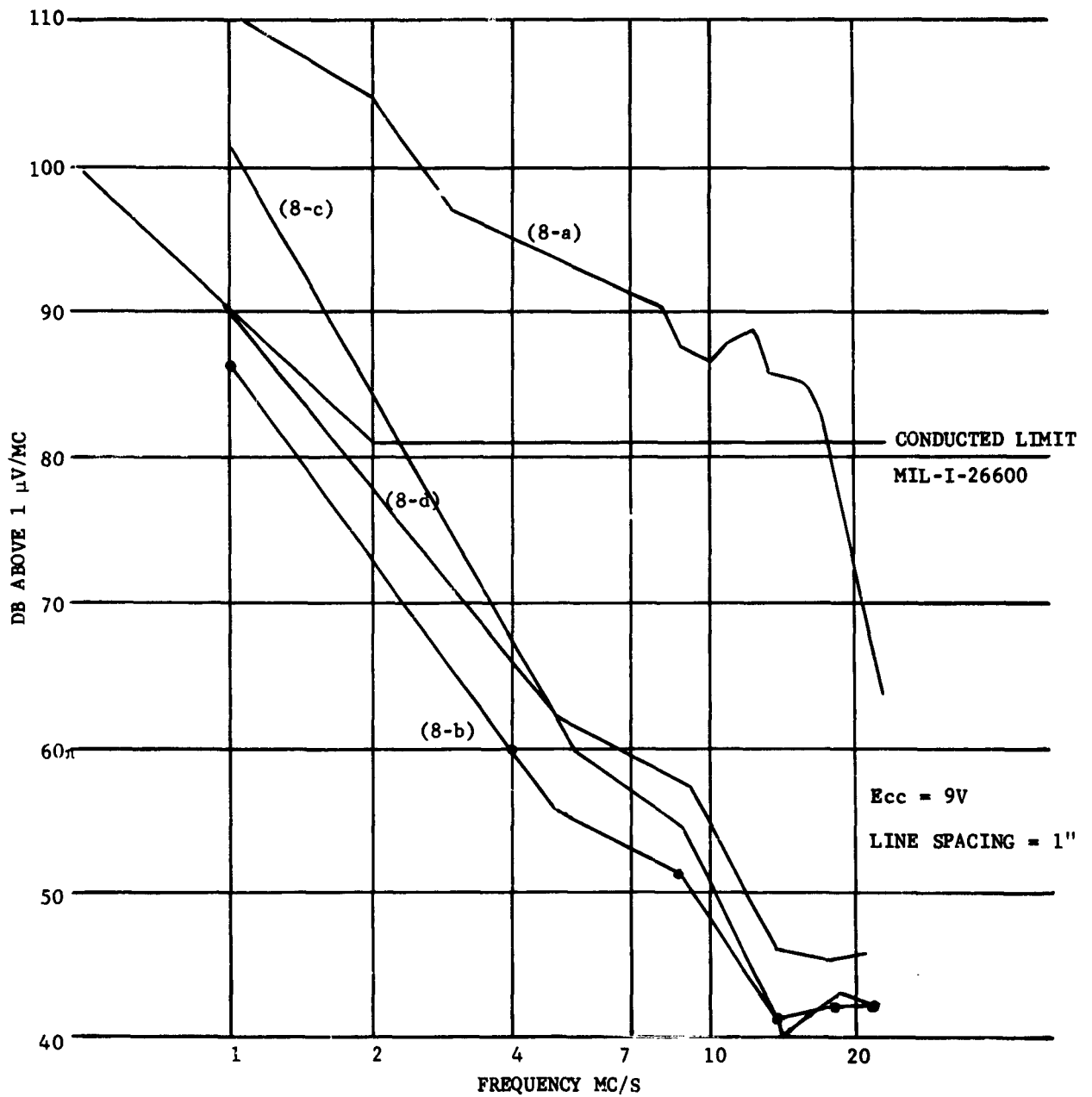

Figure 9. Conducted Interference Level for Blocking Oscillator with Decoupling Filters of Figure 8.

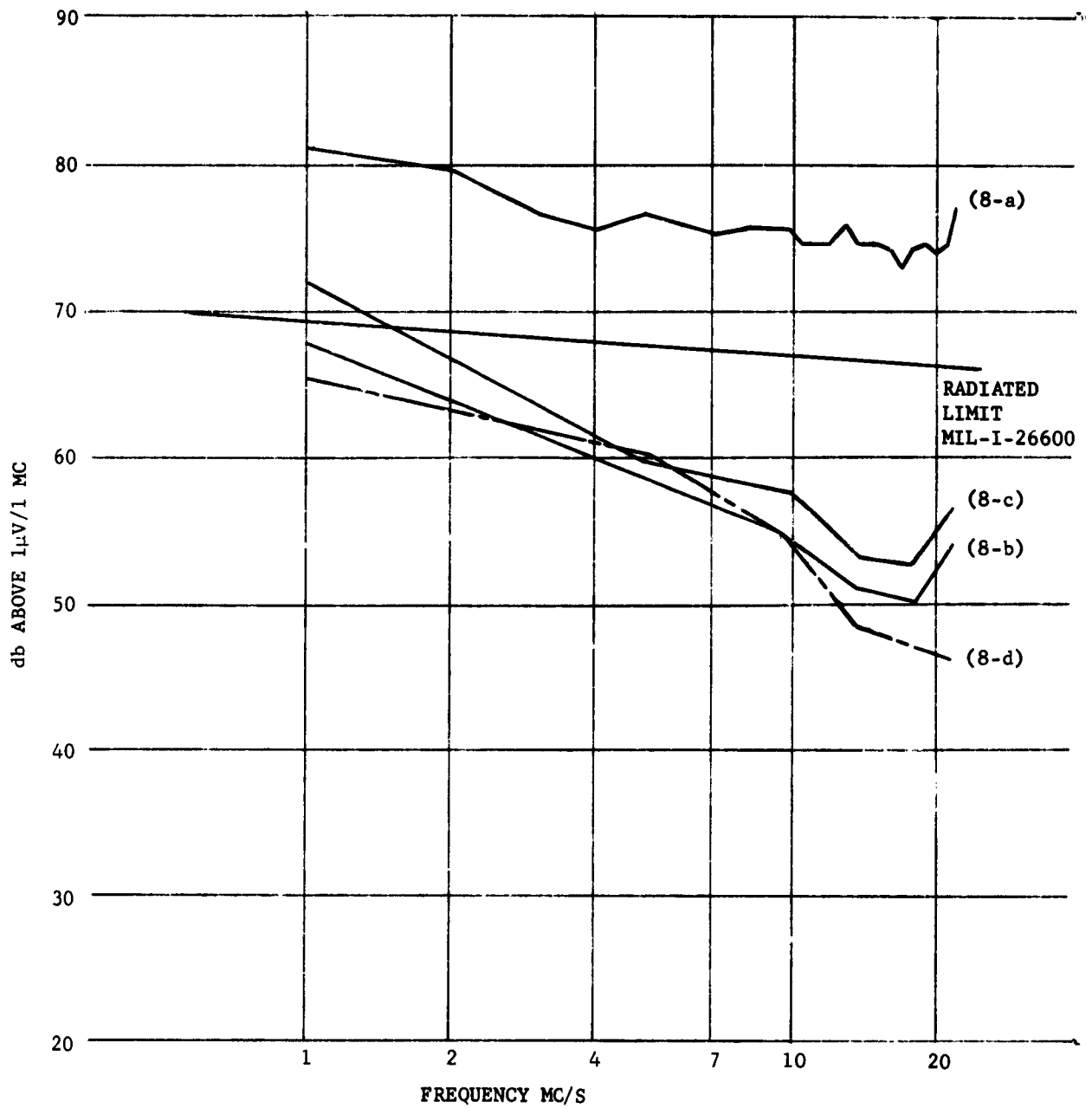

Figure 10. Radiated Levels from Power Supply Lines for Blocking Oscillator with Decoupling Filters of Figure 8.

Conducted interference tests made on the bistable multivibrator circuit again show the benefits to be gained from the inclusion of decoupling networks, shown in figure 8, (f thru h). Two tests were made including a 10 volt Zener diode as part of the decoupling network, shown in figure 8f and g. Comparison of curves for these networks with that of the network, figure 8h, where the diode was omitted (see figure 11) shows negligible differences which may be due to the absence of the diode. Basically, diodes in this class (high dynamic impedance) seem to have little or no effect in the high frequency region. A few points were repeated using a series tuned trap. This indicated the spot frequency benefits which may be derived from use of a trap circuit.

Grounding of the case was again observed to create a difference of several db in conducted levels. It is again believed that this is due to the creation of a parallel path shunting the metering circuit for some of the harmonic components.

The earliest radiated interference measurements showed only the 0.5 Mc/s point exceeding the MIL-I-26600 limit with a reading of 79 db above 1 μ v/Mc. Further radiated tests showed a reduction of this value without exceeding limits at other points in the spectrum.

c. Coil Driver Circuit

The coil driver circuit consists of a pair of cascaded transistors. Quiescent conditions are such that the first stage is turned on, the second turned off. A negative going signal turns the first stage off thus turning the second stage on. The external load is connected in the collector circuit of the second transistor. The circuit was considered of interest primarily because it is capable of switching currents in the neighborhood of 500 milliamperes.

The current drawn by this unit is sufficiently great that R-C filter sections containing reasonable values of resistance represent too great a voltage drop for satisfactory operation. A π section R-C filter was used initially, resulting in interference levels above the specification limit. The dip noted (see figure 12 curve A), in the 1 to 3 Mc/s region is due to resonances of the capacitors used.

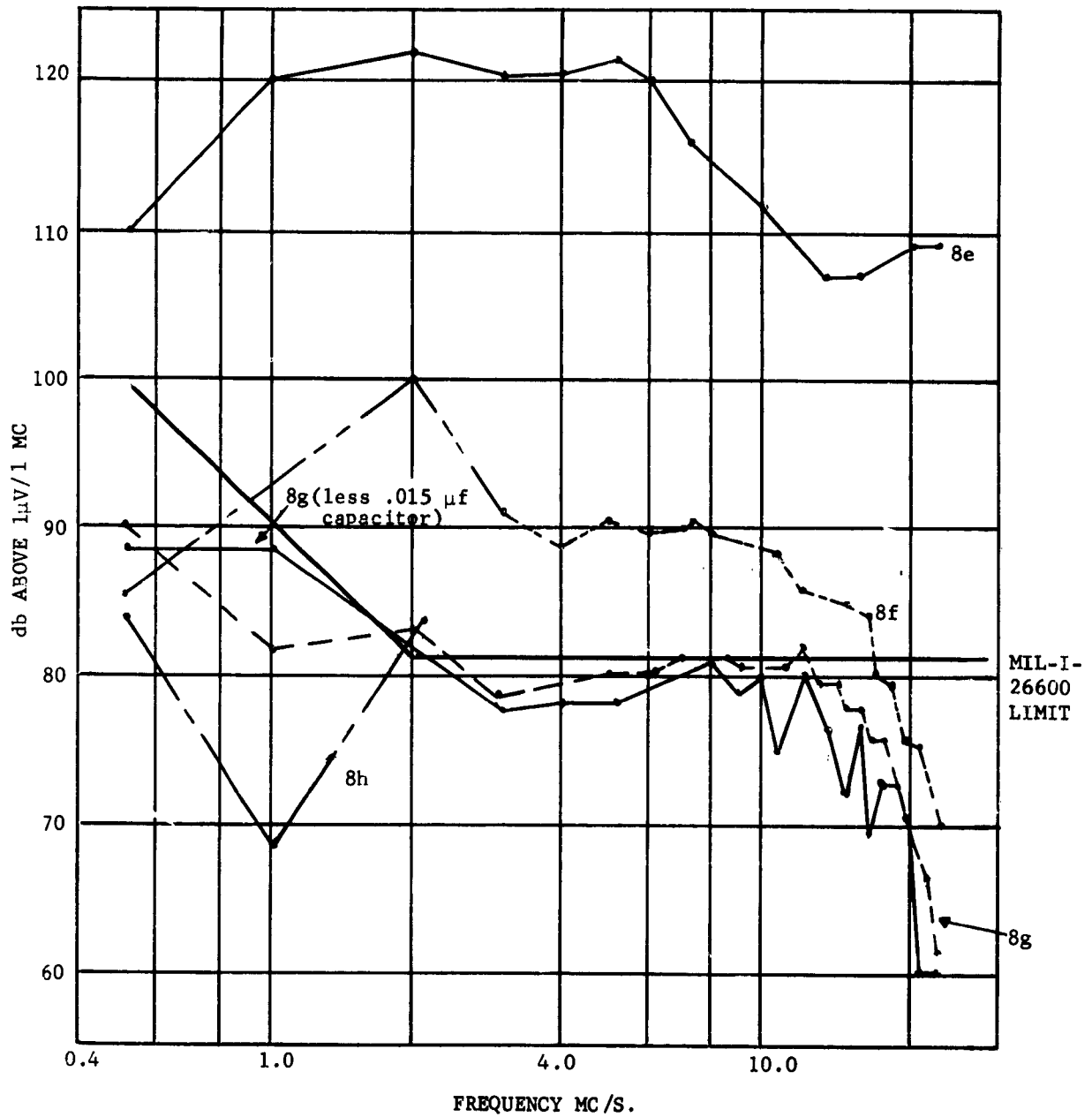

Figure 11. Conducted Interference Level of Bistable Multivibrator (Base Triggered)

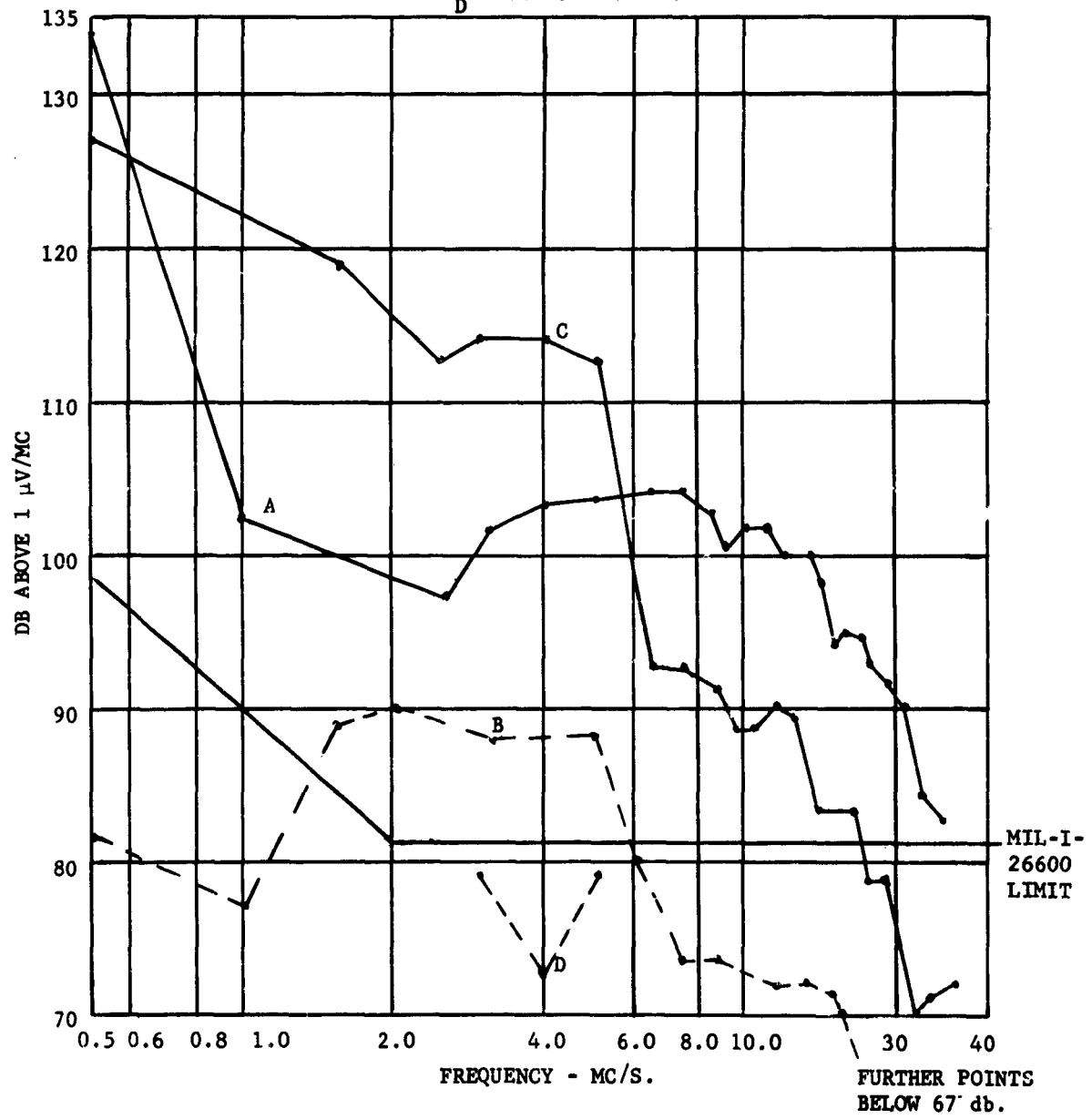
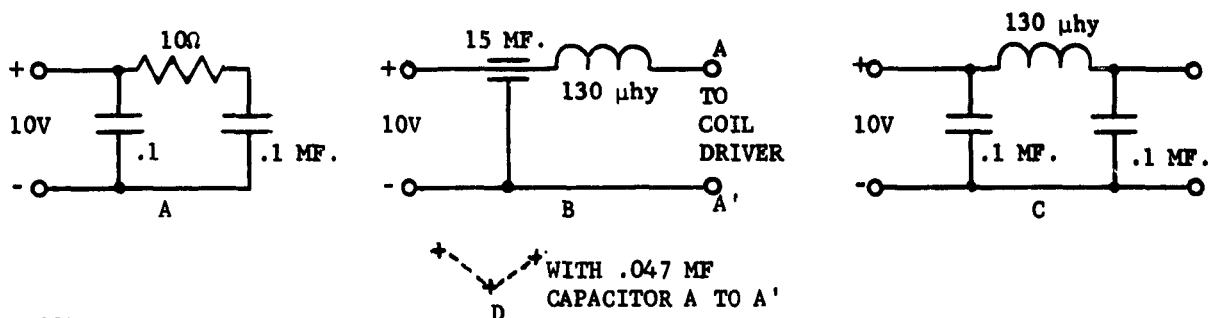

Figure 12. Conducted Interference Levels of Coil Driver Circuit.

The 10 ohm resistor was replaced by a 130 microhenry choke, self-resonant at about 8 Mc/s. The resulting curve, C in figure 12, shows a dip between 5 and 6.5 Mc/s, and remains relatively low thereafter.

The .1 μ f capacitors were removed and a 15 μ f tantalum feedthrough capacitor installed with the choke. The resulting measurements, curve B, figure 12, were below limits for frequencies below 1.5 Mc/s, and for frequencies at 6 Mc/s and above. Addition of a .047 μ fd capacitor across the output reduced the interference level in the 4 Mc/s region, as shown in curve D. This capacitor was found to be self-resonant in this neighborhood.

Formation of a series tuned trap at a particular frequency due to self-resonance should not be relied on for interference reduction. Changes in processing of the component or a change in supplier may remove the desired results. Where a series trap is required, it should be arranged in some manner such that it is subject to the designers control. Radiated levels measured from the power leads were slightly above specification levels for the last filter. Maximum level was about 70 db above 1 μ v/1 mc near 4 Mc.

d. Coupled Interference

Coupling between lines may take the forms of capacitive and magnetic coupling. The former is due to the capacitive effects between the wires of adjacent lines, while the latter is due to magnetic induction.

The magnitudes of the coupling capacitances and inductances may be evaluated, as a first approximation, by the following formulas:

$$L = \frac{\mu}{2\pi} \ell \ln \left(1 + \frac{d^2}{r^2} \right)$$

$$C = \frac{\pi \epsilon}{\ell \ln \frac{r}{a}}$$

where: d is spacing between wires of one line,
r is spacing between lines, and
a is wire diameter.

Since the inductances for the line configurations of interest (figure 13) are small, the inductive admittances are high compared to the capacitive admittances involved. The coupling mode involved in this situation, then, appears largely capacitive in nature.

For a short length of line, both terminating resistors of the receiving pair may be considered in parallel with the self-capacity of the line. Similarly, the source and load impedances of the transmitting line may be considered in parallel with the self-capacity of the line. The transmitting wire pair may be considered as one mode, while the receiving (interfered with) wire pair may be considered as a second mode. The self-admittance of each loop is represented as an admittance from each mode to ground, while the coupling admittance is represented by an admittance joining the modes. This equivalent circuit is then as shown in figure 14.

Two lines separated by variable amounts and having variable spacing between wires of the pair were operated. One line was driven by the blocking oscillator and terminated in 390 ohms. The second line was terminated in various values of resistances, and the voltages picked up by this line measured. Typical of the results were those obtained for a 1" line spacing with 1/4" spacing between lines.

For this situation, the ratio of the coupling capacitor to load capacitor is approximately .8. The voltage division ratio is then .45.

While the time constant, which consists of the product of the effective resistance and total capacitance, is long with respect to the pulse duration, the output appears as a scaled replica of the input. When the time constant is short with respect to the pulse duration, a differentiated pulse is observed. The coupling mechanism, in essence, operates as a quasi-differentiating network.

The figures obtained on the basis of these computations were almost twice the observed levels of pickup voltage. Corrections, which took into account the input capacity of the oscilloscope measuring circuit, gave a value of almost 1.29 the observed values.

As the wire spacing decreases, the error of the formula for capacitance

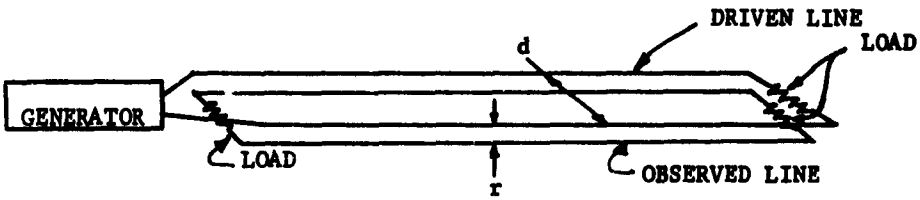

Figure 13. Adjacent Lines for Pickup Measurements

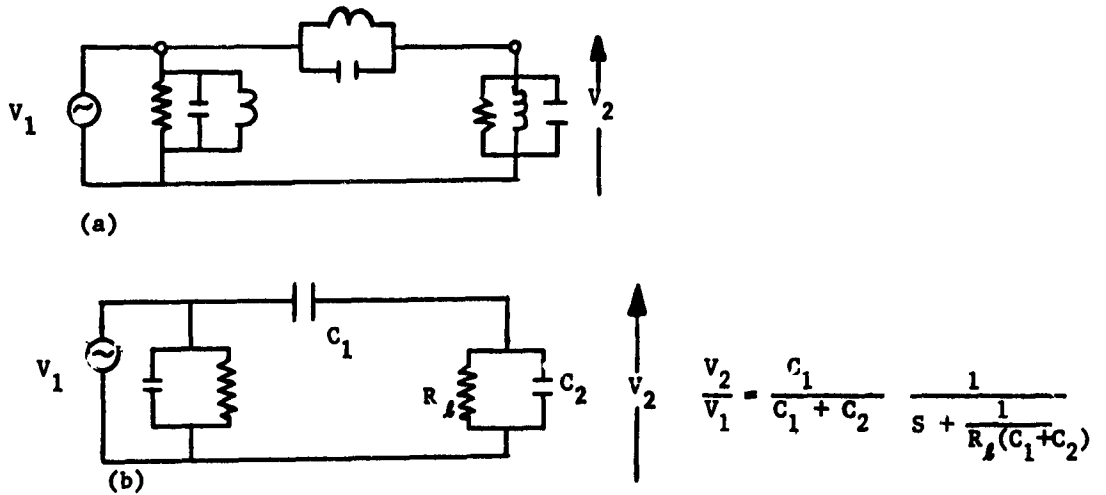

Figure 14. Equivalent Circuits.

increases. This is probably due to an approximation in the formula, which requires that r/a be large. In addition, the presence of the insulation around the wire was neglected completely, although it is not negligible for closely spaced wires. This was not considered a severe limitation, since measurements of the capacitance can be made with sufficient ease.

A further effect was noticed when all four wires were placed side by side in a square format. Here, when high resistances were terminating the lines, the mismatch ratios were quite high and standing waves were much in evidence.

A closer agreement was observed between measured and calculated values of pickup for wider spacings between the lines. The corrections for capacitive loading due to the measuring equipment was more important here, since this capacity became a larger portion of the total capacity. It is believed that use of measured values of capacity for these predictions should always result in still closer agreement.

D. INTERFERENCE SUPPRESSION TECHNIQUES

1. General

Complete suppression of interference generated by switching devices is difficult to achieve without eliminating the switching operation which is the source. It is possible to minimize the interference due to a switching action. First considered are the techniques by which minimization may take place.

Any transient phenomenon will have an interference value. This will be a function of rise time, magnitude, and duration. Techniques which will reduce the magnitude of a transient will reduce the interference caused by it. Some of these techniques are considered in the following paragraphs.

2. Resistor Suppressor

The simplest circuit element which may operate as a transient limiter is the resistor. This will find application either as a shunt element, or a series element. When used in series, it serves to limit the magnitude

of the current, while when used in shunt, it is with the intent of limiting the permissible voltage.

When, for example, a resistor is used to shunt an inductor, it limits the voltage permitted to build up when the current to the inductor is interrupted. Consideration of the circuit of figure 15a will help to demonstrate this action. If the voltage has been applied long enough, the current flow through the inductor will be E/R_1 amperes. An instant after the switch is opened, the same current must flow in the circuit, since the inductor will not permit the current to change instantaneously. Thus the maximum voltage must be $\frac{E}{R_1} (R_1 + R) = E (1 + \frac{R}{R_1})$. In the absence of the shunt resistor, R , the inductor sees a resistance path approaching infinity, and the maximum voltage may rise to values of hundreds of volts, unless an arc discharge is formed in the circuit, perhaps across the open switch contacts.

In a similar manner, a resistor might be placed across the switch contacts. Here it would serve the purpose of reducing the voltage built up across the switch to a level below that at which arcing may occur. This has the disadvantage of permitting a current to flow in the switched circuit during the off period.

A series resistor will serve to limit the maximum value of current which may flow in the circuit. Used in series with a capacitor, it will limit the initial charging current, as well as controlling the charging time constant.

The resistor is relatively small and is relatively inexpensive; however it has the disadvantage of requiring power from the source.

The resistance value must be selected in terms of the maximum voltage or maximum current to be permitted. When this is known, the voltage rating and dissipation rating may be determined on the basis of circuit conditions. Voltage limitations are specified in the applicable military specifications. Power ratings may be exceeded on an instantaneous basis, provided that the maximum temperature for the resistor is not exceeded. The permissible temperature rise, then, is dependent on a knowledge of the ambient temperature of the operating environment. Maximum temperatures

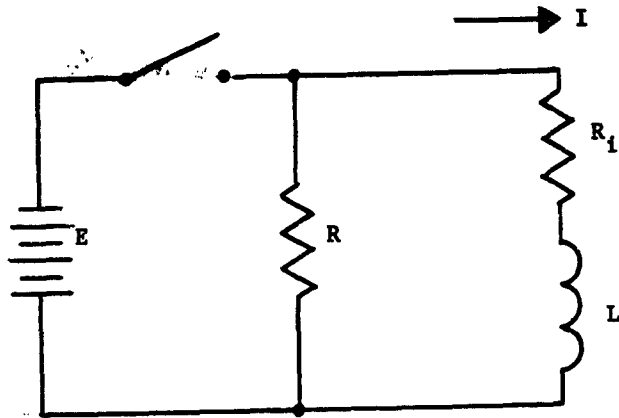

(a) Series R-L Switched Circuit

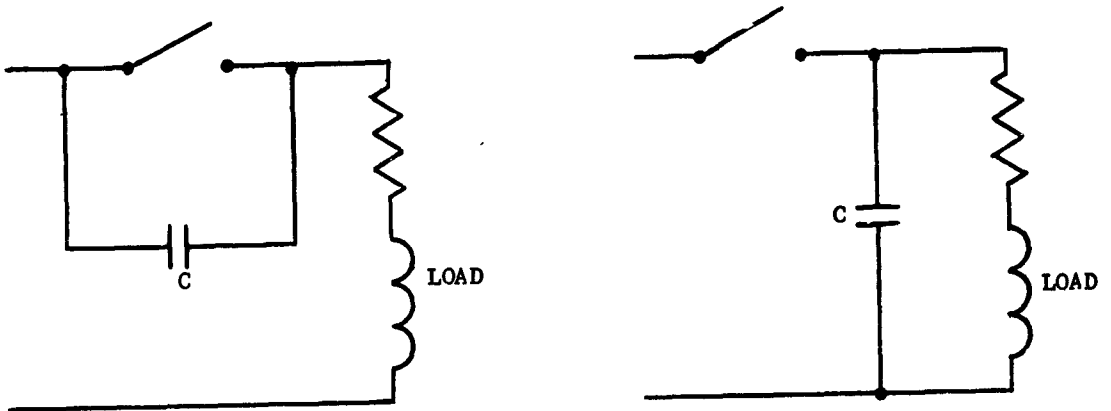

(b) Capacitor Suppression Elements

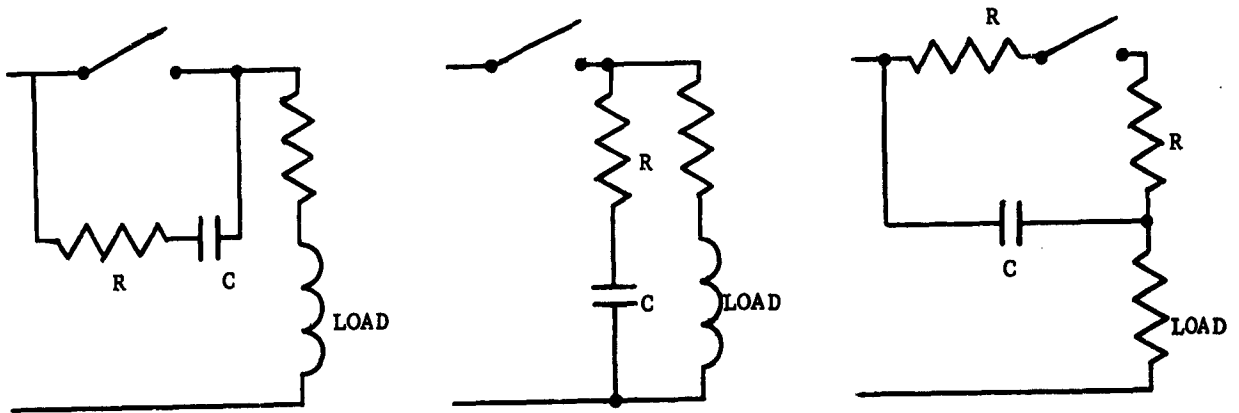

(c) R-C Suppression Elements

Figure 15. Resistors and Capacitors as Suppression Devices.

for the resistor should be obtained from the manufacturer. In general, for composition resistors, this will provide for a hot spot temperature of more than 200°C. Techniques for checking this value require the use of a thermocouple mounted at the hot spot, and application of the waveform to be used under conditions of the worst duty cycle to be considered.

In an example⁽¹⁾ of the use of composition resistors as a transient suppressors, the device was used across the actuating solenoids of a printer. Basis of the choice was cost, size, ease of installation (the resistors could be lead mounted), and adequacy of the device to provide the desired results.

3. Nonlinear Resistive Elements

Useful in essentially the same manner as resistors, are nonlinear resistors. These may be devices in which the resistance, instead of remaining essentially constant, varies inversely with applied current. Such a device may be specified such that normal applied voltage causes only a small current flow through the device, which is equivalent to a high resistance value. When the source is disconnected from an inductor, the inductor current will flow through the nonlinear resistor. This current will cause the resistance to decrease, causing the induced voltage to be lower than it would in the absence of the device. A similar argument may be presented in terms of the voltages applied to the device.

As with the linear resistor, the device has the advantage of simplicity. It should be possible to specify the unit so that power dissipation with normal applied voltage is less and discharge time constant somewhat shorter than for the resistor. Both size and cost will be greater using the nonlinear resistor.

The application notes of the manufacturers of these devices generally contain charts and nomograms to assist the designer⁽²⁾.

4. Capacitors

Use may be made of a capacitor as a transient suppression element. These may be connected across a set of switch contacts as a voltage limiting element. Such use is common in vehicular ignition systems, where their major function is to avoid arcing at the switch contacts, and consequent

increased erosion of the contacts.

They may also be found shunting relay coils⁽³⁾, and may be used with switched inductive loads generally, for the same purpose. In utilizing capacitors in this application, it is necessary to ensure that the initial current to flow in the circuit is within the capabilities of the switch. The maximum voltage which will appear across the capacitor is limited to twice the supply voltage when used in a DC system. Some applications of the capacitors are illustrated in figure 15b.

The advantages of the capacitors are that they are nondissipative in nature, and are relatively inexpensive, however they have the disadvantage of being comparatively bulky.

Selection of the capacitor to be used requires a knowledge of the circuit parameters. It is necessary to ensure that the voltage developed across the capacitor is within its ratings, that the initial charging current for the capacitor is within the capabilities of the switch, and that the circuit time constants are not lengthened excessively.

5. Resistance - Capacitance Suppressors

As stated in the preceding section, it is necessary in using a capacitor to ensure that the initial current to flow in the circuit is within the capabilities of the switch. When the external circuit will not limit this current sufficiently, the introduction of resistance in series with the capacitor will serve this purpose.

Thus, the series RC may be inserted across switched inductive loads, or across the switching contacts (see figure 15c). The resistance value is chosen to hold the initial current to a satisfactory level, while the capacitor is chosen as before⁽⁴⁾.

In general, the makers of relays having mercury-wetted contacts recommend use of such a combination across the relay contacts for contact protection. See for example, the Potter and Brumfield type JM relay catalog; where a nomogram for selecting suitable R and C values based on the load circuit, is provided.

This combination of R and C will be both larger and more expensive by the volume and cost of the additional component, than either R or C used

alone. It should have less effect on the release time of a relay or the switching time of an inductive circuit.

Further examples of the application of this combination across switch contacts are considered in available literature⁽⁵⁾.

6. Diode Suppressors

a. Single Diode

Use of a suppression element is relatively common in relay and other inductive circuits⁽³⁾. The diode is applied in the same manner as the resistor, in parallel with the coil, as shown in figure 16a. When the coil is energized, the diode is biased into a nonconductive region, while when the power source is interrupted, the diode is forward biased by the induced e. m. f. of the coil. The maximum reverse voltage which can built up is then determined by the forward drop of the diode at the maximum coil current. For the general run of germanium and silicon diodes, this will be less than a volt.

The device uses relatively little power, draining only the required reverse current from the source. Selection of the diode must be made on the basis of a reverse voltage rating greater than the applied voltage, and an ability to handle forward currents, on a peak basis, equal to the inductor current.

This device is small, more expensive than a resistor or, in general, a capacitor. It also has the disadvantage of increasing release time of a relay more than the resistor, and will have a similar effect with other inductive circuits.

The single diode may be utilized on DC circuits only.

b. Back-to-Back Diodes

For applications in AC circuits, a pair of diodes connected back to back may be used. (See figure 16b.) It is required that the reverse voltage rating of the diode be sufficiently greater than the peak voltage of the applied AC, (see figure 16c). This stipulation avoids dissipation in the diode except under conditions where transient voltages at levels greater than the diodes reverse voltage are present.

Such a circuit is also usable in a DC circuit. Under these conditions,

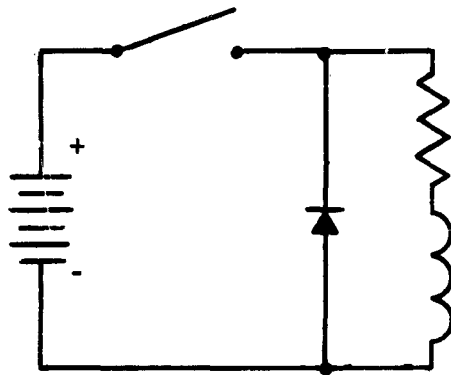

(a) Diode Suppression Element

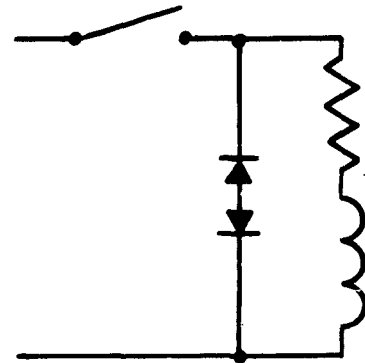

(b) Back-to-Back Diode Suppressor

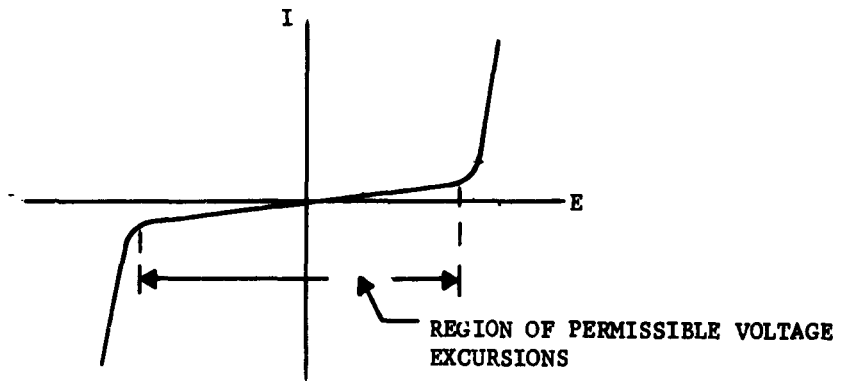

(c) Voltage Current Curve for Back-to-Back Diodes.

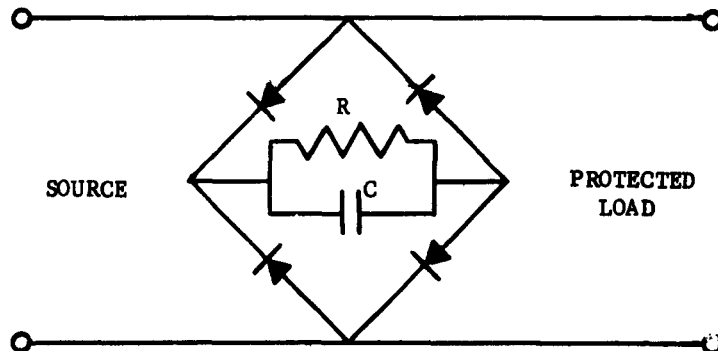

(d) Diode Bridge R-C Suppressor

Figure 16. Diode Suppressors

the maximum reverse voltage is dependent on the reverse voltage of the diode. For this application, it is common to use Zener diodes, or selenium diodes made for this purpose. These devices have greater control exercised over their reverse voltage characteristics than is true for the general class of diodes.

This device is still relatively compact, has less effect on release time than the single diode, is more expensive than the single diode of the same type, may be used with AC or DC circuits, permits a higher reverse voltage to appear in the circuit, and requires a small drain from the power source. A reasonable amount of source resistance is desirable in conjunction with the satisfactory operation of this device.

The selenium diodes have a more gradual break than the Zener diodes, and in general are larger and less expensive.

For further examples of the application of these units, bulletins of the manufacturers may be consulted. Some of these manufacturers are: General Electric, Sarkes Tarzian, Westinghouse, International Rectifier Corp., Fansteel Metallurgical Co.

c. Resistance-Diode Suppressors

For use in DC circuits where the circuit operating time is slowed excessively by use of a single diode, it is not necessary to pay the cost penalty of a second diode. This may be replaced by a resistor⁽³⁾.

During the on time, the resistor diode combination will draw only reverse current for the diode from the source. The maximum reverse voltage permitted to appear in the circuit will be controlled by the series resistor, as will the release time for a relay, or the switching time for an inductive circuit.

Requirements of the diode and resistor are the same as those for their counterparts when used individually.

d. Diode Bridge, R-C Suppressor

For use in AC circuits, a diode bridge R-C circuit has been applied as shown in figure 16d. Here the capacitor is charged to the normal peak value of the line through the diode bridge, which operates as a rectifier. Power must then be supplied only to keep it charged to this level. When

a transient voltage of greater amplitude appears, it will be dissipated in causing charge to flow into the capacitor.

The discharge time constant of the R-C must be much greater than the frequency of the applied waveform. The charge time constant of the network should be long compared to the transient duration, in order that the transient effect is "integrated out".

This circuit is relatively larger than the back-to-back diodes which it may replace, and will use about the same amount of power from the line. It should, however, be less expensive than a pair of adequate Zener diodes, and almost as effective in its clipping properties.

It will be larger in size than an R-C combination which might be used for this purpose, will require less power from the source, will be more effective and more expensive than the R-C above.

7. Line Transient Protective Devices

a. General

Relatively high amplitude long duration transients may appear on aircraft 28 volt DC supply lines. The allowable limits for such transients appear in MIL-STD-704. This specification permits a transient equivalent to an 80 volt 50 millisecond rectangular pulse which may represent a serious threat to transistorized equipment operated directly from the line, and to such semiconductor equipment as AC-DC converters and AC-DC inverters. Consideration has been given to the subject of protection against line transients, and the results are reported here.

b. Zener Diodes

A comprehensive analysis on the use of Zener diodes as protective devices against over-voltage transients is presented in Appendix I.

c. Littelfuse Transistor Protector

This device consists of a microfuse and a four-layer diode combination. The diode is connected in parallel with the load while the fuse is in series on the source side of the diode as shown in figure 17. The appearance of voltages greater than the breakover voltage cause the diode

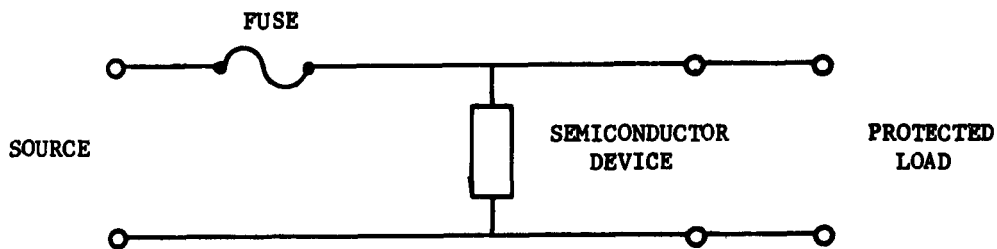

Figure 17. Littelfuse Transistor Protector

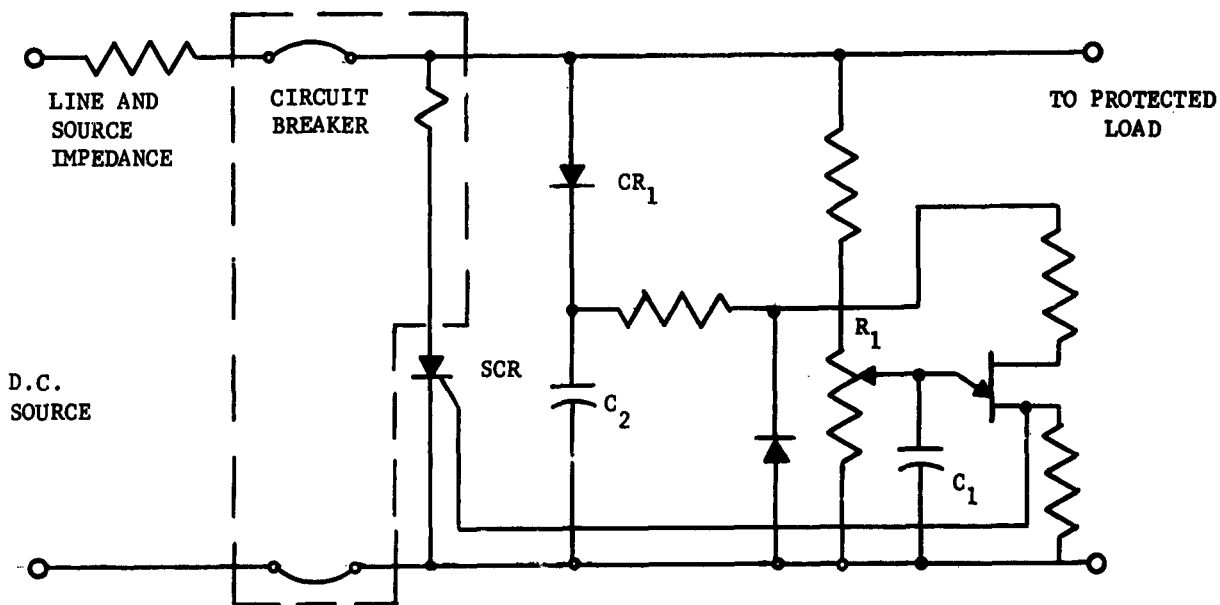

Figure 18. Electronic Crowbar for Protection of Loads Against Over-Voltage

to conduct. The conduction current is sufficiently great to cause the fuse to open. Time for the fuse to open is dependent on the current being drawn by load and diode. As an example, a ten ampere current will blow a one ampere microfuse (273001) in about 400 microseconds, while 50 amperes in the same fuse will blow it in about 30 microseconds. Since the blowing specification is 0 to 10 seconds at 200% rated current, it is apparent that several times rated current must be utilized for fast-acting protection.

The diodes are available in a variety of voltage ratings, and also with a variety of currents. Fuses of the standard Littelfuse 273000 series may be used, and these are available with current ratings from 0.002 amperes to 5 amperes. This device would be relatively small and light, can be fast enough to avoid serious damage to the protected load, and will require fuse replacement after each operation.

d. Electronic Crowbar

The electronic crowbar is a circuit which protects sensitive loads from damage due to overvoltage by forming a virtual short circuit in parallel with the load under abnormal conditions. A circuit⁽⁶⁾ for such a device is shown in figure 18.

The setting of potentiometer R_1 controls a desired maximum voltage level. When this point is exceeded by the supply, the voltage at the emitter of Q_1 exceeds the peak point voltage. This causes Q_1 to fire, and in turn the SCR is fired. The full supply voltage is then applied to the circuit breaker trip coil, and the bus is opened by the breaker. The high load placed on the supply by the SCR serves to hold the voltage available to the load down until the breaker is tripped.

The rectifier CR_1 and capacitor C_2 provide filtering against negative-going line transients which might result in false triggering of the SCR. The time constants of C_1 and R_1 are chosen to give the desired voltage time response.

The SCR is useful for this application since it will carry relatively heavy currents, and will switch in several microseconds. The major delay in this circuit thus will be the operating time of the circuit breaker,

operable in milliseconds. A disadvantage of this device is that it requires resetting of the breaker.

Since the SCR requires removal of supply voltage in order to recover control, it might simplify the situation to replace the SCR and unijunction transistor by a four-layer diode. This would simplify the circuitry. The trip voltage would depend on the four-layer diode, and control would be in the processing of the diode. Speed of operation would not be altered appreciably by this change.

Use of circuit breakers with automatic reset would make this device more convenient. It would then be possible to mount the device without appreciable regard for accessibility. Sufficient current drawn by the SCR or 4-layer diode will maintain trip in the millisecond region. Time cycle of the automatic reset is unspecified. The breakers investigated were wholly or partially operated by thermal effects. As a result, ambient temperature will affect the operating time.

e. A Limiter Using a Gate Turn-Off Switch

One of the disadvantages of the devices discussed has been a time delay for operation due to the inclusion of either thermally or electromechanically actuated elements. In order to eliminate this delay, it is desirable to eliminate the relay or fuse. One method of doing this would use a gate turn-off (GTO) switch as shown in figure 19. This device is a pnpn semiconductor much like the SCR, but providing for gated turn-off as well as turn-on. Thus, the GTO switch may be used as a series switch and the circuit arranged to open the switch when applied voltages exceed a preset level. Referring to figure 19, the action of a transient exceeding the desired level would turn on the transistor, causing a negative pulse to be applied to the gate of the GTO switch. When the applied voltage drops below the preset level, the transistor would return to a cut-off condition, and the positive pulse at the gate will turn the switch on.

Devices presently available have a relatively low dissipation rating and are available in a small physical package. As a result, despite the forward current rating of 2 amperes, it may be difficult to heat-sink the

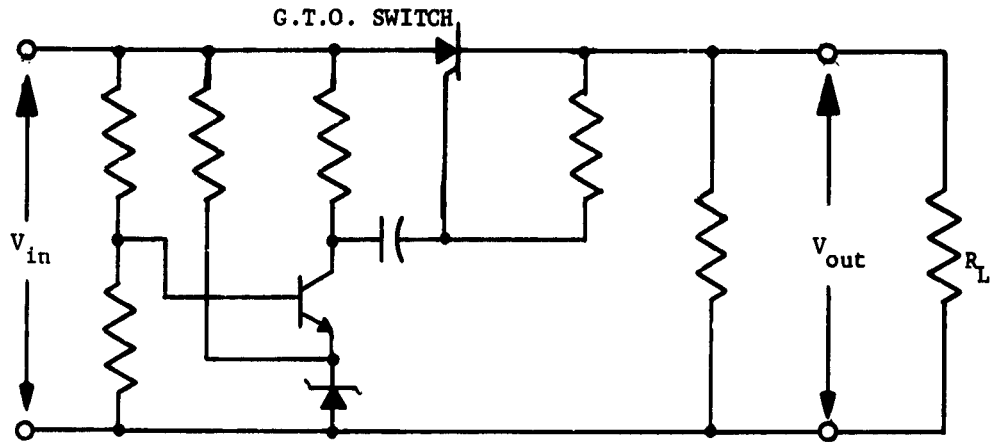

Figure 19. Gate Turn-Off Controlled Switch Limiter.

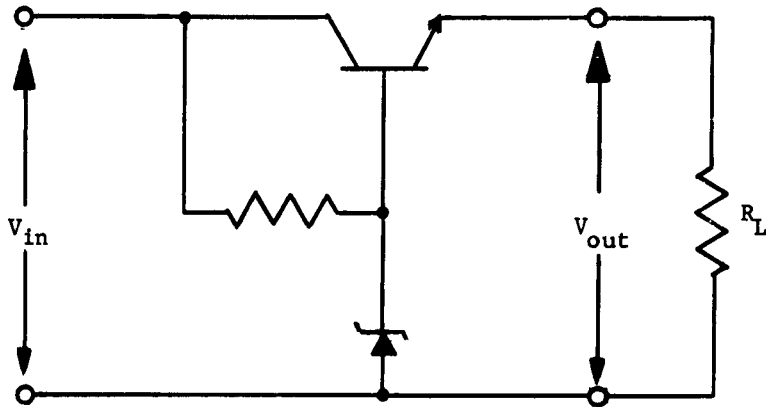

Figure 20. Emitter Follower Limiter.

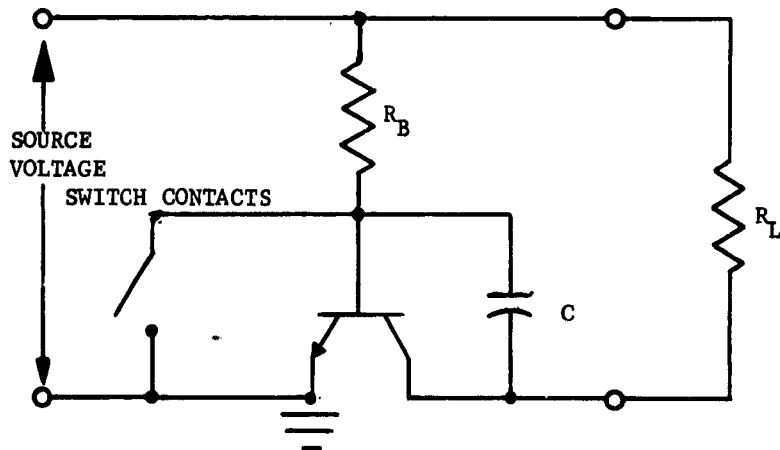

Figure 21. Transistorized Switch Control.

device sufficiently to provide for loads of even 1 ampere when ambient temperatures of 50°C are to be encountered.

f. Emitter Follower Regulator

Since the Zener diode protective circuit becomes unwieldy, both in the absence of series resistance and in the attempt to provide it, a series transistor may be used to serve as a variable resistor.

For this application, at normal line voltage, the transistor should provide a small voltage drop. As the source voltage increases, we wish the resistance to increase to maintain constant load voltage. A constant voltage from base to ground of the transistor should cause an essentially constant voltage across a load between emitter and ground. This constant voltage may be provided by use of a Zener diode.

In this operation, the transistor must be capable of withstanding a peak voltage from collector to base and from collector to emitter equal to the difference between peak collector voltage and nominal load voltage. In addition, the collector capacity should be as low as possible in order to minimize the time constant of the differentiating circuit formed by collector capacity and load resistance.

Such a circuit is apt to permit transmission of very brief transients having sharp rise and fall times almost uninhibited. These will decay with a time constant equal to the product of load resistance and effective collector capacity.

Inclusion of a capacitor in shunt with the load should provide a voltage divider action in conjunction with the collector capacity. This should help to minimize problems of transient feed-through.

Value of the resistor from base to collector is dependent on the normal collector-emitter voltage drop which may be tolerated. The number of diodes required may be determined on the same basis as for the Zener diode protective circuit as given in Appendix I. Since increasing the series resistor (from base to collector) will lower the power dissipation for these diodes, the use of a Darlington compound pair may be advantageous. This will permit the use of a larger collector base resistor, reducing the required number of Zener diodes. The circuit will require an additional

transistor, whose voltage ratings must be equal to its mates, and whose current ratings must be capable of supplying base current for the original transistor.

Design considerations for an emitter follower are set forth in the following example. For this application, it is necessary that the transistor have a high voltage rating from collector to emitter, the ability to carry the required load current, and a dissipation rating capable of handling the necessary peak power under transient conditions.

In its simplest form, such a circuit might combine a series transistor and a Zener diode controlling the base voltage, as shown in figure 20. As long as the voltage at the system input is below the Zener protective voltage, the transistor should conduct. When the voltage exceeds the diode breakdown voltage, the base and, therefore, the emitter are held to essentially the Zener voltage. The collector to emitter voltage now will increase and the transistor dissipation will increase. The transistor dissipation may be plotted as a function of time and the peak dissipation determined.

Here the dissipation is dependent on $V_{ce} I_c$, where V_{ce} is the collector emitter voltage, and I_c , the collector current, is close to the load current value. Under transient conditions, the base voltage will be held at V_z , the emitter will be about 1 volt negative with respect to the base, and the maximum load current will be about $\frac{V_z}{R_L}$. The maximum value of V_{ce} will be $(V_{s \text{ max.}} - V_z + 1)$. The dissipation rating of the transistor divided by this voltage gives the maximum permissible load current.

The load current may actually be increased slightly past this point, since the load current, and, therefore, the emitter current, is the sum of the collector and base currents.

For a 2N1016B, with $V_z = 30$ volts, $V_{ce \text{ max.}}$ will be 51 volts, allowing a collector current of almost 3 amperes. A base current of 150 milliamperes is indicated by reference to the curves. For this collector current, a base emitter voltage of about 1 volt is to be expected. If a 4-volt drop from collector to emitter can be tolerated for normal

service, 3 volts are allowed across a resistor from collector to base. This resistor must carry the base current, about 0.15 ampere. A 20-ohm resistor is required, and while normal dissipation is 0.45 watt, a 2-watt resistor would be suggested to handle the peak power involved under transient conditions. With a 30-volt Zener diode and 20 ohms of series resistance, 1.08 diodes would be required. To be rigorous, 2 diodes should be used.

Peak dissipation of the transistor may be expected at about 90 milliseconds. For a current of 3 amperes, using θ_{jc} of $0.7^{\circ}\text{C}/\text{watt}$, τ of 50 milliseconds, T_a of 55°C , and normal temperature rise of 8.4°C (12 watts \times $0.7^{\circ}\text{C}/\text{watt}$), a maximum temperature of 141°C is found.

$$\Delta T = \theta_{jc} P_c (1 - e^{-t/\tau}) = 77.2^{\circ}\text{C}$$

$$T_j = 77.2 + 8.4 + 55 = 141^{\circ}\text{C}$$

This is less than the allowable $T_{j \text{ max.}}$ of 150°C for the transistor.

One drawback of this device is the loss of voltage under normal line conditions. A possible drawback may result from the collector capacitance. If this is too great, higher frequency components may be passed by the transistor directly. Use of capacitors at input and output terminals should minimize this effect.

Change of the Zener diode from a 30-volt unit to a 21-volt unit would provide a degree of regulation. The transistor could now handle only 2.5 amperes and still run within its dissipation and maximum temperature ratings. Since a larger resistor would be permitted from collector to base, the dissipation of the Zener diode would be reduced to a point where one 50-watt diode, or possibly one 10-watt diode, would be sufficient.

8. Transistorized Switch Control

The possibility of controlling, with transistors, the rise and fall times of current and voltage transients created by switch opening and closure was investigated. One such transistor-switch combination is shown in figure 21. When the switch is open, the transistor is in saturation and is supplying current to R_L . At switch closure, the

transistor begins to turn off. The rate of change of current through R_L is inversely proportional to the value of capacitor C. Since the interference generated by the switch closure is directly related to the rate of change of base current, the amount of interference generated is reduced as capacitor C is increased in value. When the switch is opened, capacitor C controls the rate of increase in the load current by controlling the transistor base current. Investigations have been limited to resistive loads, however the technique can also be applied to inductive and capacitive loads. Other configurations are possible⁽⁷⁾.

E. FILTER NETWORKS

1. Passive Filters

Perhaps one of the most effective techniques for reducing switching device interference effects is the use of filter networks. Passive filter networks have been in use for many years, yet many equipment designers are not familiar with the analysis required in passive filter developments and applications. As an aid in the development of appropriate networks, Appendix II has been prepared. An example is presented of the synthesis of a filter having a Butterworth (maximally flat) response, and of the use of scaling techniques to modify the frequency and impedance characteristics of the filter.

2. Active Filter Networks

One of the major sources of equipment malfunctions is low frequency currents and voltage on DC power supply lines. These low frequencies may be part of the output of the power supply, or may be impressed on the supply lines either by inductive or capacitive coupling between the supply line and the surrounding electronic circuitry, or by common impedance between supply and several loads.

To minimize the effects of interference, the supply line must be filtered. The filter components required to build a low-pass filter with a cutoff frequency less than 1 kc for a DC supply line carrying one ampere or more can be objectionably large and heavy for many airborne and compact equipment applications.

Transistors can be utilized in a proper circuit configuration to provide an equivalent inductance, thereby introducing a means for more compact low-pass filter designs - the active filter network.

A portion of the study program was devoted toward exploiting this approach. Complete circuit analyses were performed together with the development and evaluation of experimental units which provide useful tools in understanding the theory and operation of active filter networks, as well as providing circuit design information. Appendix III gives complete details of the analysis and work performed.

3. Negative Impedance Converter

The negative impedance converter (NIC) is a four-terminal device containing active elements. The special property which makes the NIC of interest is that, when terminated in an impedance Z , the ideal negative impedance converter appears at its input terminals as a negative impedance of the same magnitude. This property permits the design of filters having the performance characteristics of LCR networks, but using only resistance, capacitance, and negative impedance devices.

A number of different NIC circuit configurations exist. The particular configuration selected will determine load stability for the circuit.

A comparison of the NIC circuits must consider not only their load stability, but also their ability to carry the desired load current, to withstand the desired voltage levels, to introduce small voltage drops, and to maintain characteristics over a wide frequency range.

With a circuit selected, the desired transistor parameters will be known. At this point, it becomes possible to select the transistors to be used as active elements. Once the transistor types have been established, it is possible to determine their bias requirements. It is then possible to analyze the circuit and determine its departures from the characteristics of an ideal NIC. When these departures have been established, compensating networks (which will make the nonideal NIC appear ideal) may be synthesized and their realizability determined. Departures from the ideal NIC characteristics are caused by the influence of bias elements, and by variations in transistor parameters. Appendix IV presents complete details on the studies performed.

III. CONCLUSIONS AND RECOMMENDATIONS

A. Design information has been prepared which can be utilized by equipment development engineers in reducing interference effects in electronic circuits and equipment.

B. Important inroads have been made in the development of several unique and practical suppression techniques which appear promising in alleviating switching device interference problems in aerospace equipments and systems.

C. Further research and development is recommended in the following areas:

1. Investigate the transistorized active filter networks with regard to packaging and form factors, increased attenuation and frequency coverage, increased power capacity, short-circuit proofing, and environmental effects.

2. Investigation should continue on the development of other suppression devices such as the transistorized switch control, negative impedance converter, and gate turn-off limiter which show promise in practical applications.

3. Need exists for improved techniques and instrumentation to measure and evaluate transients. An extensive study of these instrumentation problem areas should be performed with recommendations of practical approaches toward their solution.

IV. BIBLIOGRAPHY

1. Sarley, J., and Hendery, R., "Radio Interference Control as Applied to Business Machines." Proceedings Second Conference, on Radio Frequency Interference, 1956. Armour Research Foundation
2. Brownlec, T., "The Calculation of Circuits Containing Thyrite Varistors" General Electric Co. Application Note, Magnetic Materials Section
3. DeLalio, L., "Effects of Arc Inhibiting Circuits on Relay Operation." Filters Inc., Engineering Report 32.
4. DeMayer, O., "Determination of RC Spark Quenchers for Different Load Conditions." 8th Symposium, NARM 1960.
5. Schulz, R. D., "Dissipation Filters for Switching Contacts" Electronic Design, 17 Feb. 1960.
6. General Electric Co., Silicon Control Rectifier Manual, Second Edition.
7. Pecota, "Small, Lightweight RFI Suppressors using Transistors," Part 8, IRE Convention Record 1958.

APPENDIX I

OPERATION OF THE ZENER DIODE AS A PROTECTIVE ELEMENT

A. INTRODUCTION

At first glance, the Zener diode is an extremely attractive protective device. It is relatively small, light, comparatively inexpensive, and offers a measure of protection against overvoltage transients when connected in shunt with a load. The major condition which must be met for this device to operate in a satisfactory manner is the inclusion of sufficient resistance between source and diode. The necessity of this condition will be demonstrated in the following discussion.

B. EQUIVALENT CIRCUIT OF A ZENER DIODE

A Zener diode may be drawn with an equivalent circuit such as that shown in figure I-1a. The switch represents the diode and the battery represents the breakdown voltage, above which the diode switches, and appreciable current can flow. The resistance in series with the battery, R_Z , represents the Zener resistance, or the dynamic impedance of the diode, in its breakdown region. The shunt resistance, R_C , represents the leakage resistance of the diode when biased below the breakdown voltage. The shunt capacitor, C , represents the junction capacity of the diode. With the exception of the battery, each of these quantities is a variable. The junction capacity and leakage resistance are both voltage sensitive, while the Zener resistance is current sensitive for any given diode. The leakage resistance is relatively high, the Zener resistance relatively low. The current which will flow through the diode is dependent on the difference between the applied voltage and the Zener voltage, and the total of source and Zener resistance (see figure I-1d). The only assumption here is that source resistance is small compared to load resistance. In order to keep the maximum load voltage at a level not much greater than the Zener voltage of the diode, the source resistance must be large compared to the Zener resistance. One of the ways in which

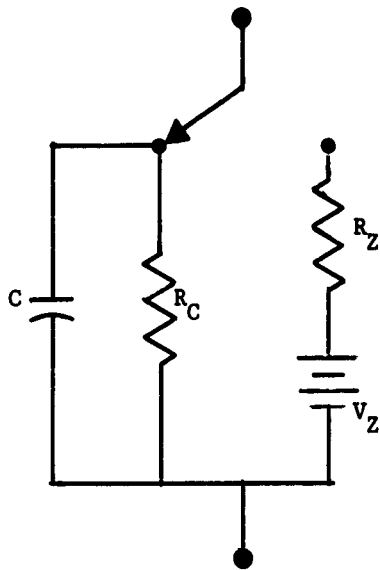

(a) Equivalent Circuit of a Zener Diode

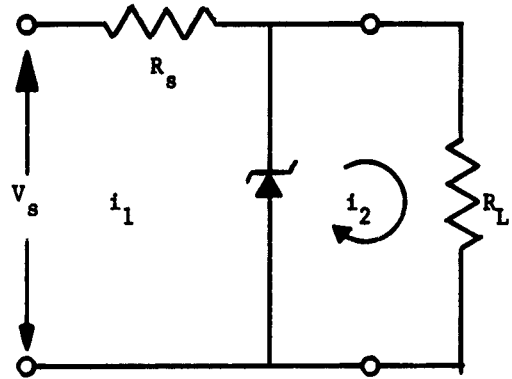

(b) Circuit for Zener Diode as a Protective Element

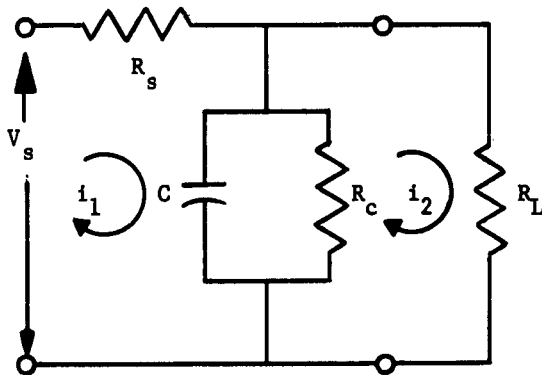

(c) Equivalent of Protective Circuit for V_s Below Diode Breakdown Voltage

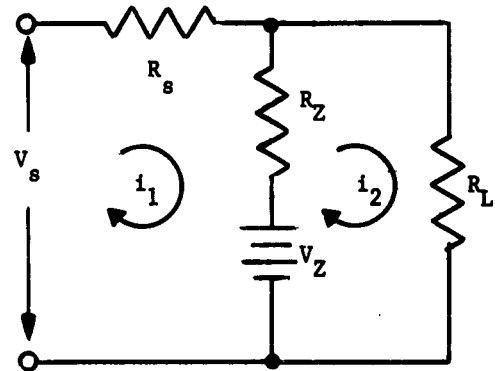

(d) Equivalent of Protective Circuit for V_s Above Diode Breakdown Voltage

Figure I-1. Zener Diode Equivalent Circuits

this can be done is to insert series resistance. This may keep the load voltage from reaching desirable levels during normal operation, as well as negating the initial assumption ($R_S \ll R_L$).

In the absence of sufficient series resistance, the required number of Zener diodes increases greatly. The number of diodes needed is dependent on the total power to be dissipated and therefore on transient amplitude, Zener voltage, circuit resistance (source and Zener impedance), duration of transient, thermal resistance and thermal time constant of the diodes, ambient temperature at which operation is to take place, and the maximum allowable junction temperature.

C. ANALYSIS OF CIRCUIT

One area in which protective devices are required is an aircraft 28 volt DC bus. Since the limit case transients are specified in MIL-STD-704, this application was considered in detail. The circuit shown in figure I-1b and the equivalent circuits of figure I-1c and d apply. The equivalent circuit of figure I-1c applies for source voltages below the Zener voltage while the equivalent circuit of figure I-1d applies when the source voltage exceeds the breakdown voltage. The Zener resistance, R_z , is usually sufficiently small that the capacity, C , can be neglected in comparison, while R_c is sufficiently large that C must be considered for any transient considerations.

1. Zener Current

For the conditions of figure I-1c, the Zener current is negligible, and it is for the conditions of figure I-1d that Zener current must be found. From the equivalent circuit, the following relations are found:

$$V_s - V_z = (R_s + R_z) i_1 - R_z i_2 \quad (I-1)$$

$$V_z = R_z i_1 + (R_z + R_L) i_2 \quad (I-2)$$

where R_s is source resistance, R_z is dynamic Zener resistance and R_L is load resistance. The Zener current, I_z , is seen to be the difference of the loop currents, i_1 and i_2 and may be expressed as:

$$I_z = \frac{V_s R_L - V_z (R_s + R_L)}{R_s R_L + R_z (R_s + R_L)} \quad (I-3)$$

From MIL-STD-704, paragraph 3.18, the maximum allowable line drop is 2 volts. From this, we find that $(R_s + R_L)/R_L$ is less than 1.08. Under these conditions, we may express the Zener current as:

$$I_z = \frac{V_s - V_z}{R_s + R_z} \frac{\frac{R_s + R_L}{R_L}}{\frac{R_s + R_L}{R_L}} \approx \frac{V_s - V_z}{R_s + R_z} \quad (I-4)$$

2. Allowable Dissipation

The allowable dissipation of a Zener diode, as for other semiconductor devices, is restricted by the maximum junction temperature, $T_{j \text{ max.}}$, permitted. For a nonrecurrent pulse, where the Zener voltage is greater than the normal line voltage, the case temperature may be assumed to be at ambient temperature, T_a . The difference between maximum junction temperature and case temperature defines an allowable temperature rise, ΔT for the junction. The rise in junction temperature may be related to the thermal resistance of the device, θ_{jc} , the power dissipated by the device, P_z , the thermal time constant of the device, τ , and the time since the start of the transient, t .

$$\Delta T = \theta_{jc} P_z (1 - e^{-t/\tau}) \quad (I-5)$$

The power dissipated in the diode is a product of the Zener voltage, V_z , and the Zener current.

$$P_z = V_z I_z = V_z \frac{V_s - V_z}{R_s + R_z} \quad (I-6)$$

3. Maximum Temperature Rise

Expression (I-6) may be used to replace P_z in expression (I-5).

This leads to:

$$\Delta T = \theta_{jc} V_z \frac{V_s - V_z}{R_s + R_z} (1 - e^{-t/\tau}) \quad (I-7)$$

Multiplying both sides of the expression by $(R_s + R_z)$ yields:

$$\Delta T (R_s + R_z) = \theta_{jc} V_z (V_s - V_z) (1 - e^{-t/\tau}) \quad (I-8)$$

A time plot of expression (I-8) is shown in Figure I-2. For the 35-volt Zener diode, the maximum value is seen to be about 2,760, and is reached at about 80 milliseconds after the start of the transient. The diode junction reaches maximum temperature at the peak of the curve. On the same curve, plots of expression (I-8) for Zener voltages of 20, 30, 50, and 60 volts are shown for comparison.

4. Quantity of Diodes Required

The allowable maximum temperature for these devices is 175°C. An ambient temperature of 55°C, and, therefore, a case temperature of 55°C, allows a temperature rise of 120°C.

The maximum number of diodes required, N, is dependent on the maximum value of ΔT , as determined above, and the values of R_s and R_z .

$$N = \frac{\theta_{jc} V_z (V_s - V_z) (1 - e^{-t/\tau})}{\Delta T (R_s + R_z)} \quad (I-9)$$

D. EFFECT OF VARIATIONS

Examination of the effects of variation in the parameters influencing the solution of expression (I-9) shows that:

Changes in V_s will obviously affect the required number of diodes. The worst case of V_s , however, is called out by the specification, and, as this limit is used, need not be examined further.

Changes in V_z will influence the required value, as seen in the plots of figure I-2. Here we find that, for V_z in the range of 35 to 40 volts,

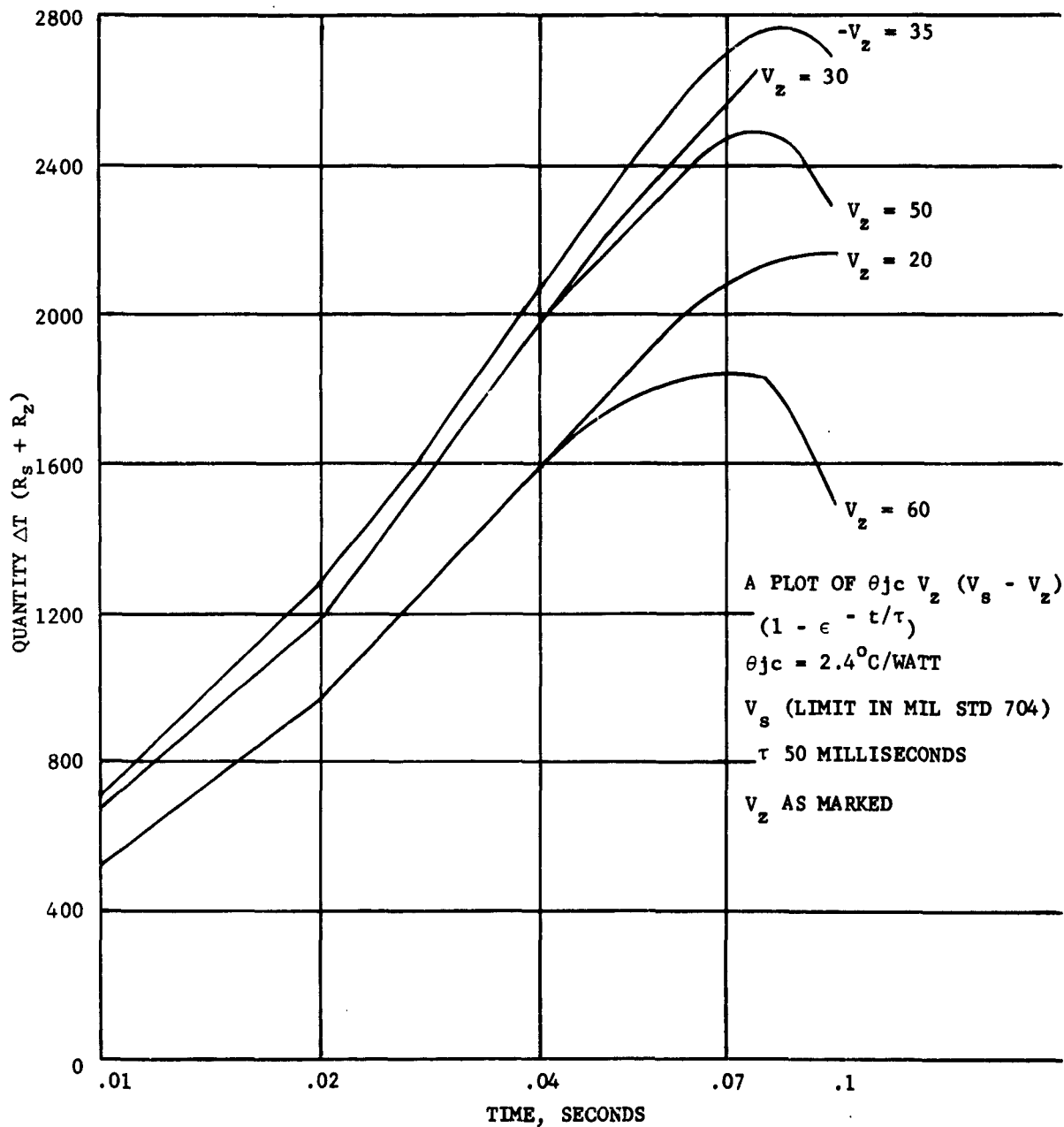

Figure I-2. Time Plot of Expression (I-8)

higher peaks of $\Delta T (R_s + R_z)$ are reached and more diodes will be required.

Changes in θ_{jc} will influence N in a direct manner, with N decreasing as θ_{jc} decreases.

A decrease in ambient temperature will cause a decrease in the value of N. An increase in the maximum allowable junction temperature will cause a decrease in the value of N.

Changes in the thermal time constant, τ , causes N to vary in an inverse manner; that is, increasing values of τ will cause N to decrease. Variations of both R_s and R_z will cause N to change, with increases of either R_s or R_z causing a decrease in N. For Worst Case Analysis, we take V_s as given by the specification limit, V_z of a value satisfactory to guarantee the life of the equipment, θ_{jc} as a maximum value, τ either as a minimum value or a value appropriate to the thermal resistance chosen, the minimum value of R_z , the minimum value of R_s consistent with the load, and the maximum ambient temperature to be encountered. V_s is the limit 1 curve of figure 6 from MIL-STD-704, T_a is 55°C , V_z is 35 volts, and R_s is 1 ohm. From the diode data sheet, we find that $T_{j \text{ max.}}$ is 175°C , and $\theta_{jc \text{ max.}}$ is 2.4°C per watt. The only value of thermal time constant available is a typical value of 50 milliseconds. Under the circumstances, this will serve. R_z is assumed to be zero initially, an assumption which will be examined in more detail later. Using the maximum value of $(R_s + R_z) \Delta T$ from figure I-2, we find N to be 23 diodes.

E. ADDITIONAL CONSIDERATIONS

1. Minimum Value of R_z

The problem of determining a satisfactory value of R_z to be used in this analysis is difficult. In addition, for a parallel configuration of several diodes, the resultant resistance is quite low. For this reason, the initial assumption of zero resistance was made. For a Worst Case Analysis, it is the minimum value of Zener resistance which must be evaluated.

Information from one manufacturer states ". . . there is no way to determine the minimum from the published maximum values. Z_{zt} (which we

have referred to here as R_z) is controlled to be below the maximum published value. There is no control on the minimum Z_{st} . A Z_{st} of zero would be the condition for a maximum ΔT in this application . . . "(I-1). A second manufacturer states ". . . No lower limits are established to dynamic impedance but they are fixed by the nature of the avalanche characteristics of the junction The minimum dynamic impedance to transients is marked by the junction capacitance "(I-2).

2. Thermal Time Constant

The thermal time constant is the product of the thermal resistance and the thermal capacitance. As has been pointed out, the thermal resistance is quoted as having a maximum value of $2.4^\circ\text{C}/\text{watt}$, while for the same group of diodes, typical values of $1^\circ\text{C}/\text{watt}$ are cited.

Again, quoting one source, ". . . The thermal resistance and capacitance are a direct function of the physical size. The $2.4^\circ\text{C}/\text{watt}$ maximum thermal resistance is to protect the manufacturer, as well as give the customer a useable figure to work with. The solder thickness, diffusion depth, etc., affect the value of thermal resistance. The thermal capacitance is generally constant and will vary with only the case. The $2.4^\circ\text{C}/\text{watt}$ is seldom encountered; however, this must be considered in designing a circuit "(I-1).

3. Heat Sink Requirements

At this point, no mention has been made of heat sink requirements. The value of thermal resistance used has been that of the diode alone. For nonrecurrent pulses, heat sinks will be of value only where their time constant is short compared to the time constant of the diode itself.

4. Cooling

Reduction of ambient temperature will reduce the required number of diodes for the protection system. Reduction through the use of full-time cooling equipment will represent an undesirable increase in volume, weight, and power consumption. Transient use of such equipment will be ineffective

(I-1) Letter from Mr. J. Takesuye, Applications Engrg., Motorola, Inc.

(I-2) Letter from Mr. N. Lambert, Standard Rectifier Corp.

due to the long thermal time constant involved. A semiconductor thermal electric cooler, for example, has a 1.5 minute thermal time constant under no-load conditions.

5. Insertion of Additional Source Resistance

It is possible to insert series resistance only when a transient exists. This will permit operation at supply voltage during normal conditions, while providing protection during transient condition. The additional resistance may be inserted in the circuit by means of a relay actuated by the transients. Careful control of the relay is necessary to provide fast operation, and to maintain separation of minimum pull-in and maximum drop-out points at limit temperatures.

The number of Zener diodes required will now be a function of the operating time of the relay. The resistance value to be used will be determined by the maximum voltage to be protected against, its duration, and the number of diodes used.

This means of protection is apt to be fairly large, either in terms of diodes or relay.

F. EXAMPLE

$$V_s = \text{Limit 1, figure 6, MIL-STD-704.}$$

$$V_z = 35 \text{ V}$$

$$R_s = 1 \text{ ohm}$$

$$T_a = 55^\circ$$

$$\theta_{jc} = 2.4^\circ\text{C/Watt}$$

$$\tau = 50 \text{ milliseconds}$$

$$T_{j \text{ max}} = 175^\circ\text{C}$$

$$P_z = V_z I_z = V_z \frac{V_s - V_z}{R_s + R_z} \quad (\text{Expression I-6})$$

$$\Delta T = \theta_{jc} P_z (1 - e^{-t/\tau}) \quad (\text{Expression I-5})$$

$$\Delta T = \theta_{jc} V_z \frac{V_s - V_z}{R_s + R_z} (1 - e^{-\tau/\tau}) \quad (\text{Expression I-7})$$

$$\Delta T(R_s + R_z) = \theta_{jc} V_z (V_s - V_z) (1 - e^{-\tau/\tau}) \quad (\text{Expression I-8})$$

From the curve in figure I-2:

$$\Delta T(R_s + R_z)_{\text{max.}} = 2,760$$

$$\Delta T = T_{j \text{ max.}} - T_a = 175 - 55 = 120^\circ\text{C}$$

$$N_{\text{max.}} = \frac{2760}{120 (R_s + R_z)} = 23$$

$$R_s + R_z \text{ min.} = 1 \Omega \therefore N = 23$$

APPENDIX II

PASSIVE FILTER DESIGN TECHNIQUES

A. INTRODUCTION

Passive filters are widely applied in the interests of interference reduction. In the particular area of switching interference, the major application of filters is in power leads to reduce conducted interference. This appendix presents an example of the synthesis of a filter having a Butterworth (maximally flat) response, and of the use of scaling techniques to modify the frequency and impedance characteristics of the filter. Proper utilization of the latter tools will permit rapid development of appropriate networks for prototype purposes.

B. LOW-PASS FILTER CHARACTERISTICS

Filters are used to restrict transmission to desired frequency components along a given path. The ideal shape for the transmission region, or passband would be a rectangular block as illustrated in figure II-1a. This consists of a flat-topped transmission region, infinite slope skirts, and a zero transmission stopband or attenuation region. Thus, for any filter, three regions of interest may be defined. These are the passband the stopband, and the transition region. Additionally, the designer is interested in the impedance levels at the source and load ends, and the maximum passband attenuation and minimum stopband attenuation desired.

Armed with this knowledge, and the voltage and power levels to be handled, filters with particular characteristics may be designed. There is a large store of knowledge in this area which may be applied, particularly with regard to the design of constant-k and m-derived filters. The available design aids take the form of graphs and nomograms, showing the number of sections required to give a desired shape factor to the transition region, and relating cutoff frequency, impedance level, and component values.

The constant-k filters represent one technique for approximating the ideal attenuation characteristics for a filter. The approximation improves with the addition of more filter sections.

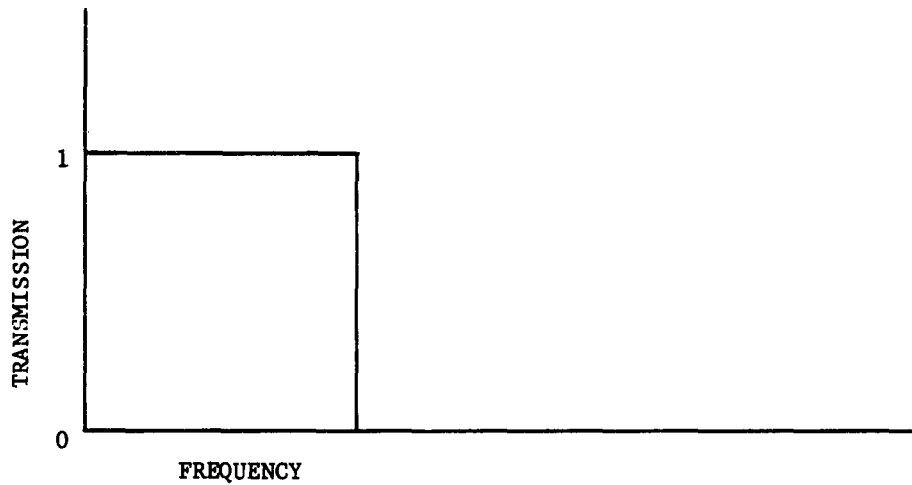

(a) Ideal Low Pass Filter Characteristic

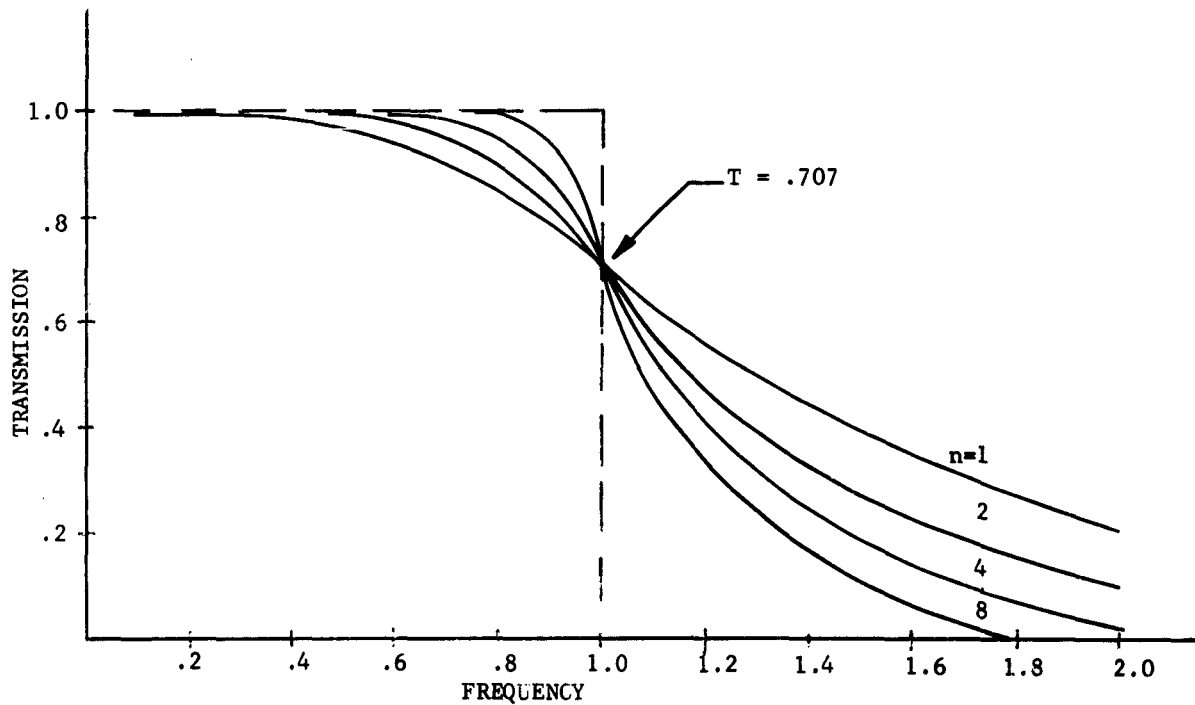

(b) A Comparison of the Ideal Low-Pass Filter Characteristic and Some Butterworth Approximations

Figure II-1. Filter Characteristics

These filters are designed to operate from a given source impedance to the same load impedance. Operating into an improper load will affect both the passband and stopband attenuations. In general, where this situation exists, an increase in attenuation is apparent. The magnitude of this increase is a function of the mismatch.

A degree of freedom from the requirement for equal loading at input and output ends of the filters was realized with the development of image parameter design techniques. In filters intended for RFI suppression, the power source is relatively low impedance, while the termination consists of whatever load is applied to the circuit. On the other hand, the load is also capable of acting as an RFI source, with the power source as a load. This situation would lend some support to the design of filters for this application capable of operating between a zero impedance on one end (power source) and an open circuit or finite impedance at the other end (load). In RFI testing, the line stabilization network (LSN) is inserted between the power source and filter. The LSN appears, from the load side, as a resistance essentially equal to the terminating impedance at frequencies above 2 Mc/sec. Below this frequency, the impedance decreases, and is in the neighborhood of 5 ohms at 100 kc/sec. Some minor changes of driving point impedance may be caused in the region below 200 kc/sec. by changing the power source output impedance.

C. BUTTERWORTH APPROXIMATION TO THE IDEAL FILTER

A second technique of approximating the ideal filter lies in the synthesis of a network to some approximating polynomial. One of the functions often used for this purpose is the Butterworth, or maximally flat, function. This is derived by approximating the ideal function with a Taylor series about zero frequency. The resulting function may be of any desired degree. If the polynomial is of degree n , the first $n-1$ derivatives will be zero, and this has led to the maximally flat designation. All of the polynomials generated will have an amplitude of 0.707 at the characteristic, or cutoff frequency. Since this corresponds to one-half the maximum power level, this point is often referred to as the half-power frequency.

The Butterworth function is always equal to the desired function at zero and infinite frequencies, and always has a constant error at the characteristic frequency. The approximation at other points in the spectrum is improved by increasing the degree of the polynomial used, as shown in figure II-1b.

D. OTHER APPROXIMATION TO IDEAL FILTERS

Further improvements may be made by using another approximating function. One of the functions used is the Tchebychev polynomial. This yields an equal ripple approximation to the desired function within the passband. Thus, a zero error approximation to the ideal may be made at any desired number of points within the passband. In addition, the steepness of the skirts may be improved, compared to the Butterworth functions, for a given number of network elements.

Yet another approximating function which may be used is the Jacobian elliptic function. Here, an equal ripple approximation is employed in both the passband and the stopband. Again, for a given number of elements, steeper slopes in the transition region may be obtained than with either the Butterworth or Tchebychev functions.

E. A NETWORK SYNTHESIS EXAMPLE

Once the desired approximating function has been obtained, the problem becomes one of synthesizing a network to provide this response. During the past three decades, much work has been accomplished in this area. As a result, a large number of techniques have been demonstrated. These techniques permit the synthesis of a network on the basis of either a prescribed magnitude function, or a prescribed phase function.

For any given function, provided that it is realizable, a group of networks may usually be synthesized. A relatively simple example will be shown. A low-pass filter is desired to operate from a zero impedance source into a 50-ohm load. This network is to have a half-power point at 100 radians per second, and a maximally flat transfer impedance.

Since it is usually considered desirable for a filter to end in a capacitor at each end, the simplest structure would use a third degree Butterworth polynomial. Thus,

$$Z_{12} = \frac{1}{s^3 + 2s^2 + 2s + 1} \quad (\text{I-1})$$

Following the work of Darlington, we may write:

$$Z_{12} = \frac{z_{12}}{1 + z_{22}} \quad (\text{II-2})$$

and
$$Z_{12} = \frac{1}{s^3 + s^2 + 2s + 1} \quad (\text{II-3})$$

The denominator may be broken up into odd and even portions. By dividing the numerator and denominator by the even portion, we force the expression into the form of equation (II-1)

Thus,

$$Z_{12} = \frac{\frac{1}{2s^2 + 1}}{1 + \frac{s^3 + 2s}{2s^2 + 1}} \quad (\text{II-4})$$

1. Cauer Development of a Network

At this point, several techniques for developing the network are available. However, by noting that all zeros of the transfer function are located at zero, a shortcut is available. One cover development of z_{22} must yield a network which will have the desired poles to satisfy the expression for Z_{12} . In addition to being a rapid and simple technique, the Cauer development, through continued fraction expansion of a driving point impedance, has the advantage of providing a network with a minimum number of elements which realizes the prescribed response.

2. Impedance Scaling

At this point, the network figure II-2a has component values in

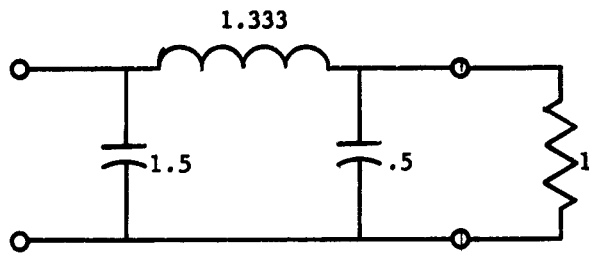

(a) Low-pass Filter Having Butterworth Response $n = 3$, 1-Ohm Load, 1-Radian Bandwidth

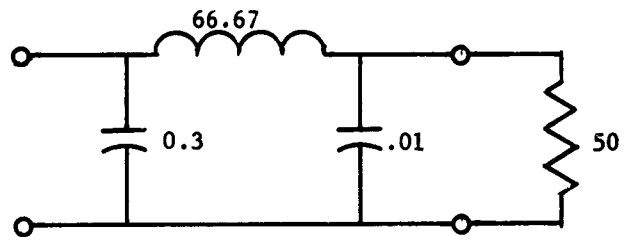

(b) Low-Pass Filter of Fig. 9 Scaled for 50-Ohm Load

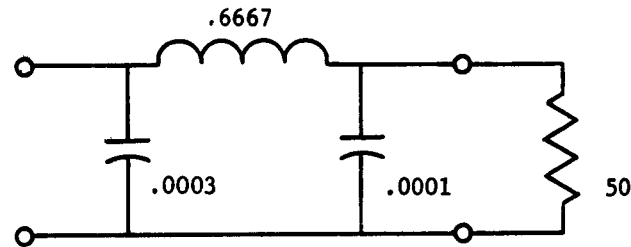

(c) Low-Pass Filter of Fig. 9 Scaled for 50-Ohm Load, 100 Radian Bandwidth

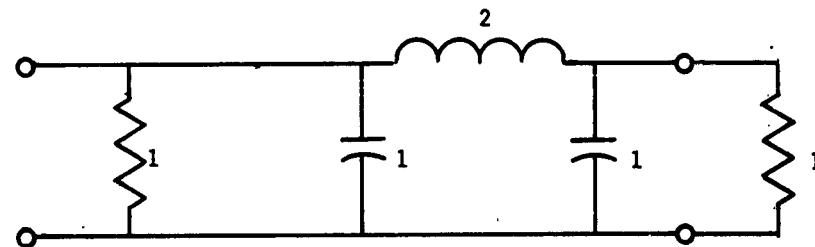

(d) Low-Pass Filter Having Butterworth Response $n = 3$, Terminated at Each End.

Figure II-2. Three-Pole Butterworth Filters

henries and farads, a one-ohm terminating resistance, and a cutoff frequency of one radian per second. Impedance scaling yields a network of figure II-2b which is terminated by 50 ohms. In order to scale the impedance, all impedance values are multiplied by the desired factor. All resistance and inductance values are multiplied and all capacitance values divided by the scaling factor. Impedance scaling in this manner has no effect on the frequency response of the network.

3. Frequency Scaling

Frequency scaling, which should have no effect on the impedance level, is accomplished by dividing all inductance and capacitance values by the scaling factor. The scaling factor is the ratio of the desired characteristic frequency to the one radian normalized bandwidth. Application of frequency scaling yields the network shown in figure II-2c. This network has a 50-ohm load, 100-radian bandwidth, and a maximally flat response.

4. A Double-Loaded Network

With a modification in the initial techniques, the Butterworth filter can be synthesized as a network loaded at each end. For a three-pole transfer impedance, with equal values of terminating resistance, the resultant network is shown in figure II-2d. This is identical to a single section of a constant k filter. Since both filters have a 3 db loss (compared to zero frequency loss) at the characteristic frequency, this identity should be expected. This identity is not true with a larger number of sections. The constant-k filter will provide 3-n db loss at the characteristic frequency for an n-section filter, while the Butterworth filter will always provide 3 db loss at this point, and will be properly terminated in a single value of resistance at all frequencies. The constant-k filter can be designed to use a minimum number of component values, but in general, requires a complex termination in order to deliver the design attenuation.

F. AN EXAMPLE OF FREQUENCY SCALING TO AN ARBITRARY ATTENUATION

Frequency scaling of networks need not be restricted to the characteristic frequency. It is just as applicable to scale the point of a

desired attenuation value. A group of prototype filters (having a one ohm load and one radian bandwidth) may be thus converted to provide a given level of attenuation at a particular frequency. To illustrate, three prototype maximally flat filters are compared. These are the three-pole network we have previously considered, and a five-pole and a seven-pole network. The transfer impedances for these networks are:

$$Z_{12} = \frac{1}{s^3 + 2s^2 + 2s + 1},$$

$$Z_{12} = \frac{1}{s^5 + 3.236s^4 + 5.236s^3 + 5.236s^2 + 3.236s + 1}$$

and

$$Z_{12} = \frac{1}{s^7 + 4.94s^6 + 10.0978s^5 + 14.592s^4 + 14.592s^3 + 10.0978s^2 + 4.94s + 1}$$

The circuits of these filters are shown in figure II-3, and their response in the transition region is plotted in figure II-4. Scaling the five-pole and seven-pole networks so that the 60 db points for all three networks coincide results in the circuits of figure II-5. The appropriate transition region responses are shown in figure II-6.

Comparison of the total inductance and total capacity required shows a decrease in the totals for both the seven-pole and five-pole as compared to the requirements for the three-pole. For a given operating voltage level, the volume displaced by capacity will vary directly as the capacity varies. Similarly, for a given current rating, the volume displaced by an inductance will vary as the square root of the inductance value. The capacity volume decreases as a result of increasing the number of sections, while the inductance volume appears to increase.

Thus, there is no readily apparent size advantage in using a larger number of sections. The most obvious advantages from using the larger number of sections are: 1) sharper slope (steeper skirts); 2) greater bandwidth in the passband; and 3) smaller component values resulting in fewer problems with parasitic resonances.

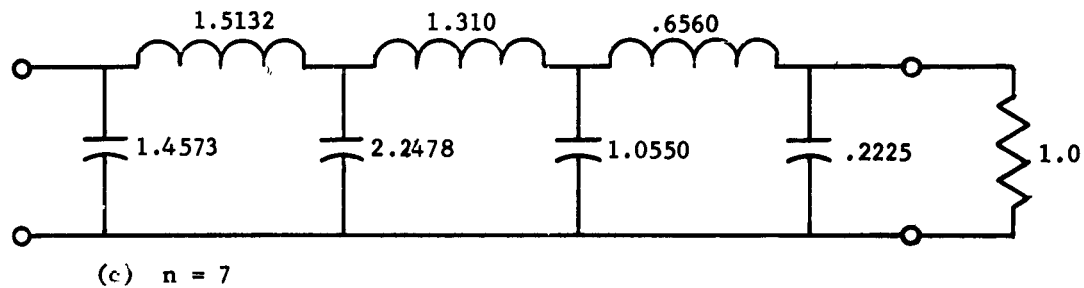
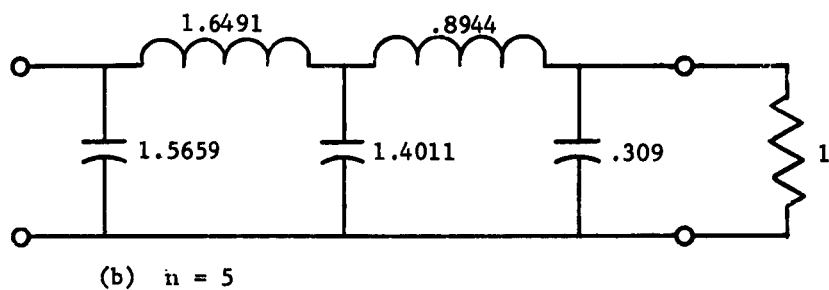
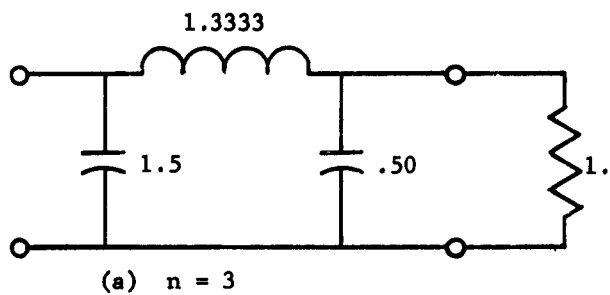

Figure II-3. Prototype Low-Pass Filters Having Butterworth Response

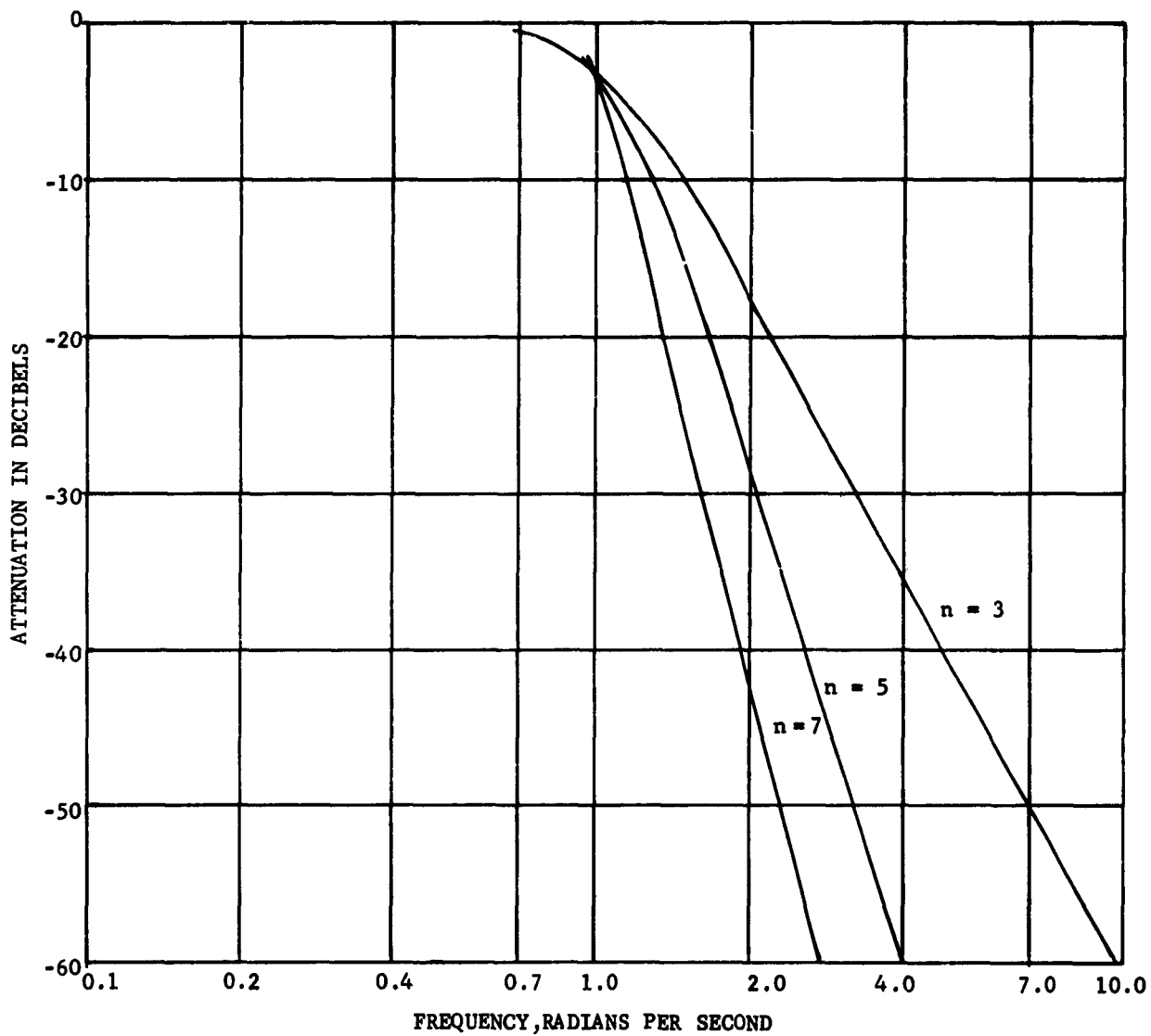

Figure II-4. Transition Region Responses for the Networks Shown in Figure II-3

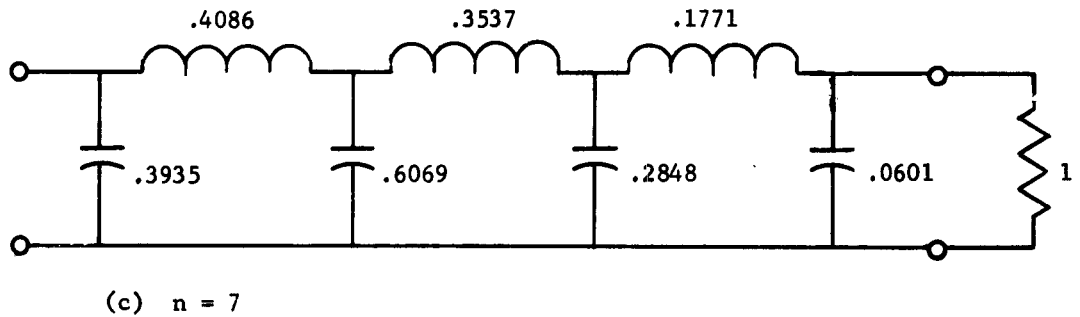
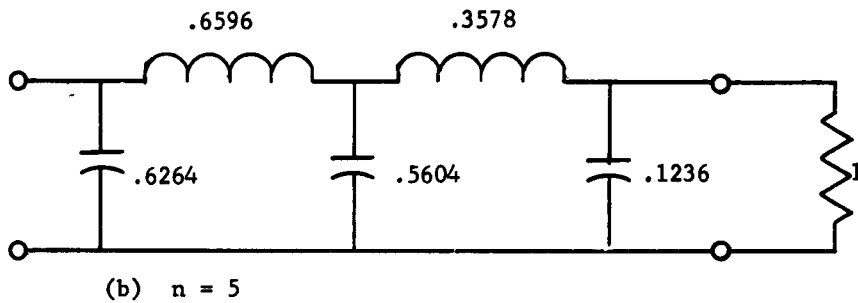
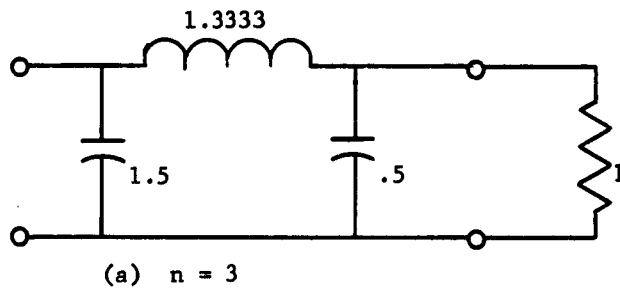

Figure II-5. Butterworth Filters with Values scaled to Provide 60 db Attenuation at Common Frequency

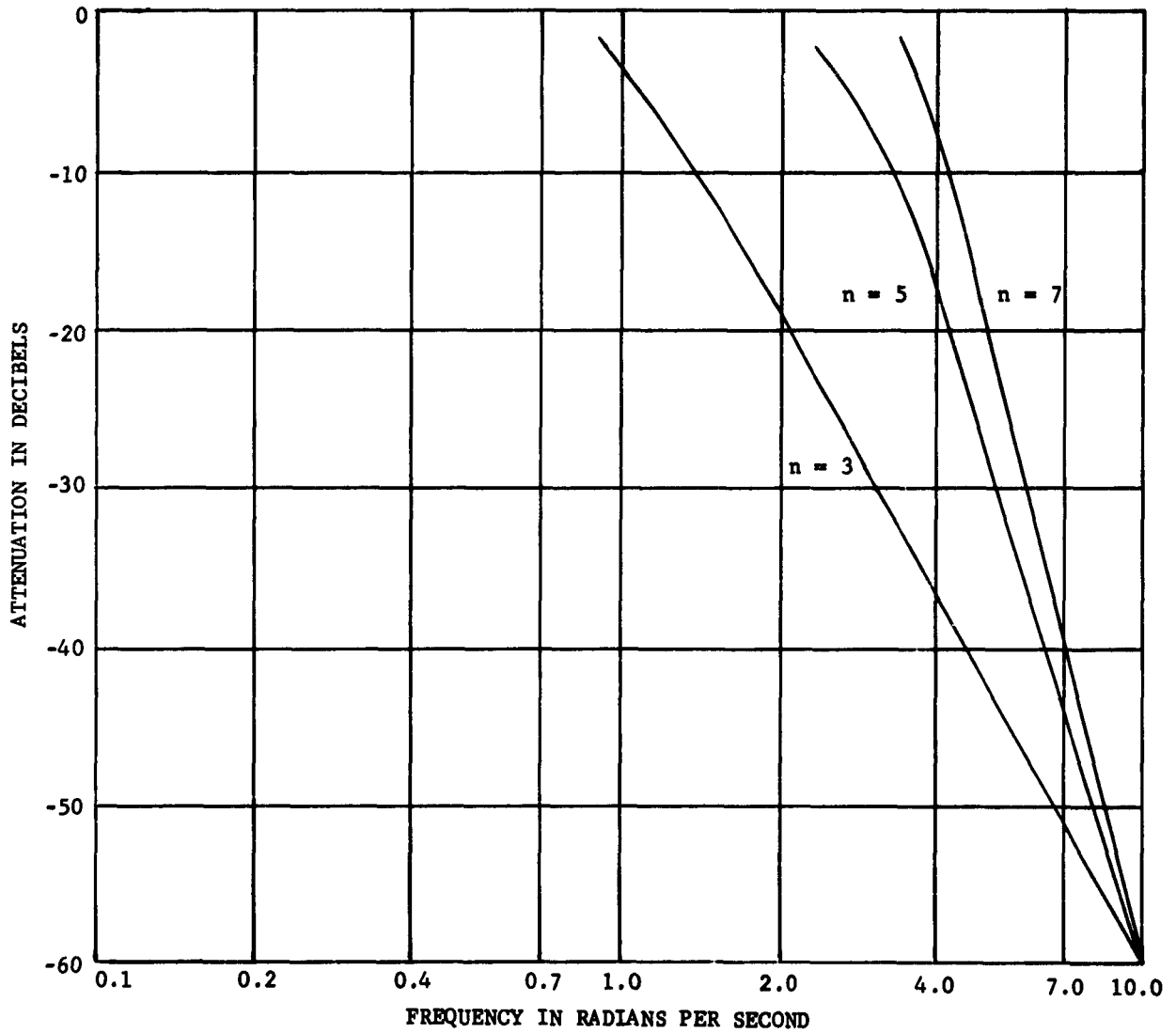

Figure II-6. Transition Region Response for the Networks of Figure II-5

G. R-C FILTERS

An additional group of filter networks are the R-C filters. Their advantages are a relatively small size and a freedom from magnetic field pickup at low frequencies. These filters will usually (for low-pass applications) have a relatively high insertion loss at DC, when low load resistances are employed, so that only relatively high resistance loads are satisfactory.

To investigate the RC filter, a comparison was made of three configurations providing the same flat loss, and using the same total of R and C. The R and C were divided up to form two L sections, and these then combined as a T, a Π and a cascade of 2 L sections for comparison. (Figure II-7a.)

No significant difference in attenuation characteristics appears for the T- and Π -sections, while the cascade of L sections has a skirt with twice the slope, and about 20% greater bandwidth to the 3 db point. (Figure II-8.)

The voltage transfer functions appear as:

$$\frac{V_{out}}{V_{in_{\Pi}}} = K \frac{1}{s + 1.82},$$

$$\frac{V_{out}}{V_{in_T}} = K \frac{1}{s + 1.91}, \text{ and}$$

$$\frac{V_{out}}{V_{in_{L's}}} = K \frac{1}{.909s^2 + 1.91s + .1}.$$

The symmetry of the T- and Π -structures would provide equal attenuation in both directions with equally loaded filters. This would not be true of the cascaded L-sections. For usage as an RFI filter, the equal loading would be extremely unlikely to occur. Under these conditions, asymmetrical attenuations may be expected of all the filter sections considered.

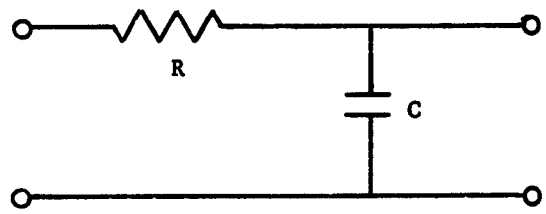

(a) Prototype Half-Section

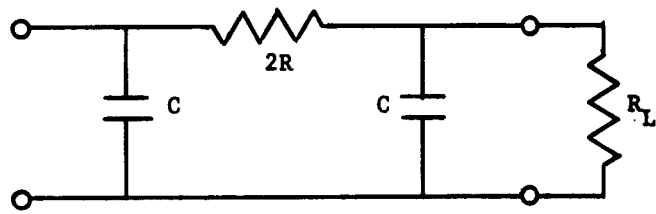

(b) Pi Section

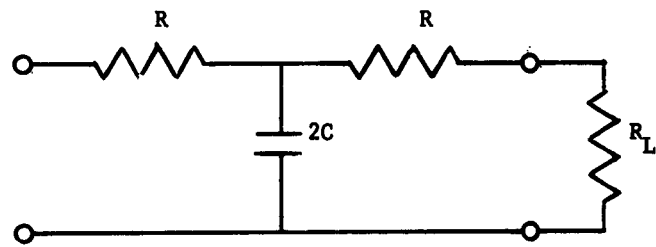

(c) Tee Section

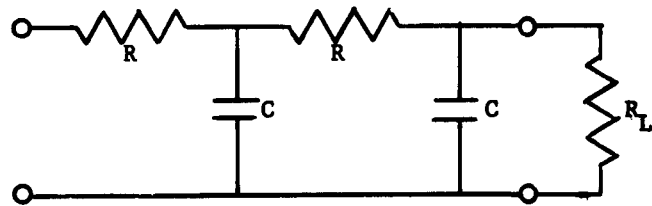

(d) Cascaded Half-Sections

Figure II-7. Some R-C Filter Combinations

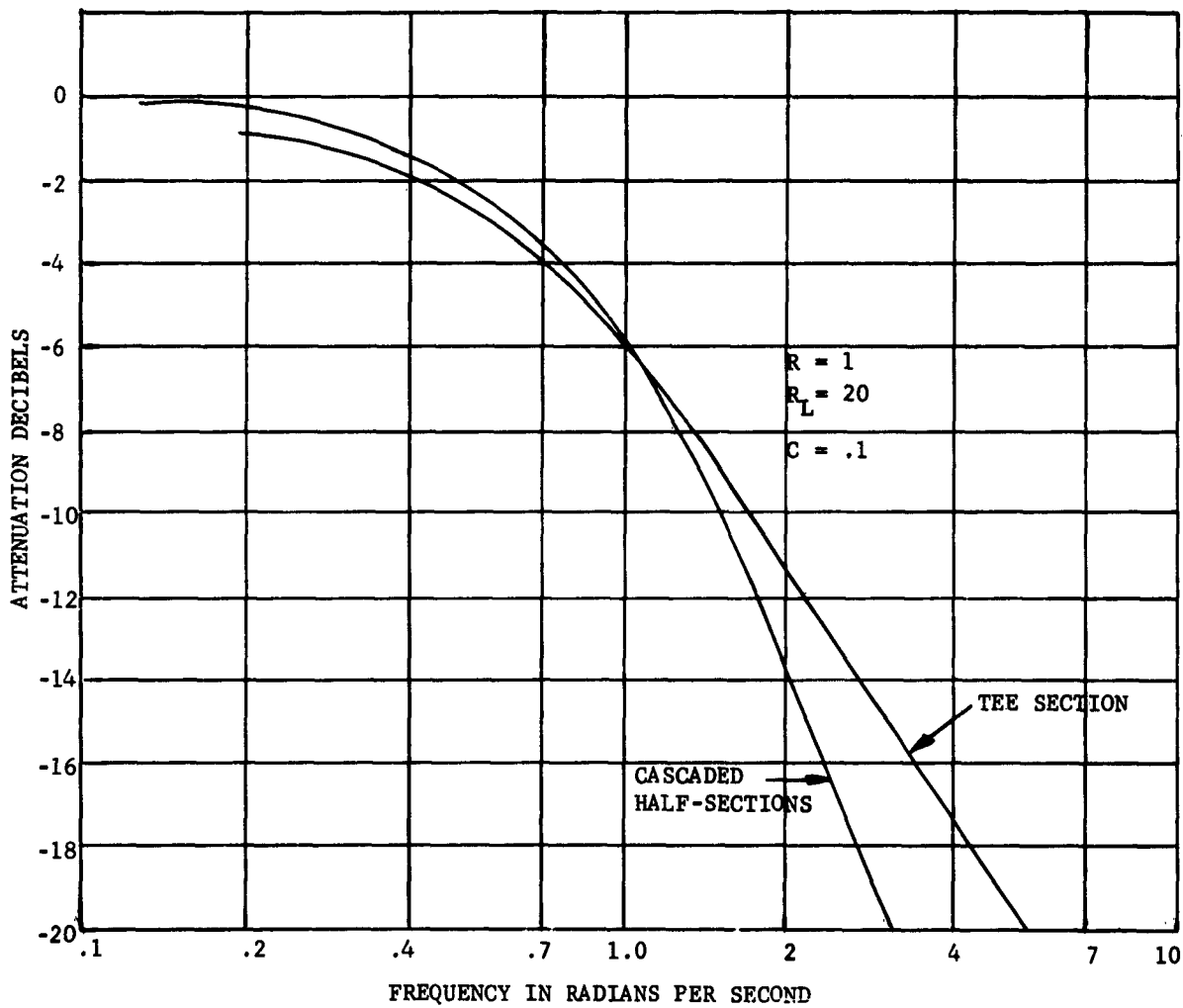

Figure II-8. Attenuation Curves for Cascaded Half-Sections and Tee-Sections. (Curves for Pi Section almost Overlaps that of Tee-Section).

H. CONCLUSIONS

A network having a Butterworth transfer function may be synthesized by a Darlington treatment of the transfer function, and one network developed, simply, by Cauer expansion of a resulting driving point function. The resulting prototype network may be scaled in impedance and frequency to give the desired characteristics. The major advantage of using a filter of several sections to achieve a prescribed attenuation at a specific frequency will probably lie in a steeper skirt, greater bandwidth in the passband, and fewer problems with parasitic resonances resulting from smaller component values.

In R-C networks, for a given total resistance and capacity, the use of a cascade of L sections will provide a skirt with steeper slope and greater bandwidth to the three db point than use of the same elements in a T or Π filter.

APPENDIX III
INVESTIGATION OF ACTIVE FILTER NETWORKS

A. GENERAL DISCUSSION

In many applications, low frequency currents and voltages present on DC supply lines may cause malfunction of electronic circuits. These low frequencies may be part of the output of the power supply, or may be impressed on the supply lines either by inductive or capacitive coupling between the supply line and the surrounding electronic circuitry or by common impedances between supply and several loads.

To prevent these low frequencies from entering an equipment, the supply line must be filtered. The filter components required to build a low-pass filter with a cutoff frequency less than 1 Kc/s for a DC supply line carrying one ampere or more are usually large and heavy. In some applications, particularly for compact airborne equipment, the size and weight are prohibitive. To reduce the size and weight of the filter, an active network containing transistors may be used. This Appendix discusses the properties of two such filter networks.

This study was divided into two phases. The first phase was an investigation of the filtering characteristics of the circuit shown in figure III-1. This circuit has been used as a ripple clipper on DC supply lines. The second phase was an effort to develop a light, small, and economical, low-pass filter. This filter was intended to carry one ampere, with good attenuation over the frequency range from 40 cps to 100 Kc/s. The configurations used were series regulators designed to work with only two or three volts insertion loss at DC.

B. RIPPLE CLIPPER CIRCUIT

1. Scope of Investigation

An analysis made of the operation of the ripple clipper circuit of figure III-1 follows: Although no attempt has been made to study the circuit's dependence upon temperature, the analysis does relate the characteristics of the circuit to the transistor parameters. Once the nature of the temperature variation of these parameters is known, the temperature

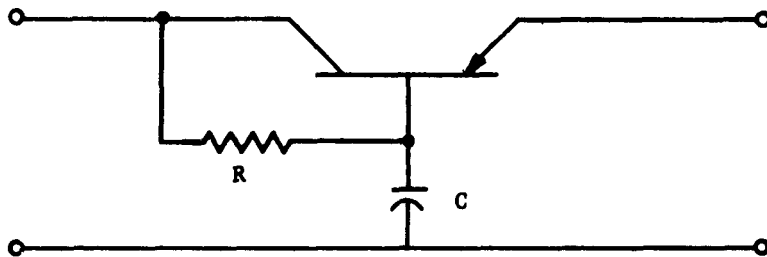

Figure III-1. Schematic Circuit Diagram Basic Transistor Filter

dependence of the circuit characteristics may be obtained.

The analysis will be divided into two frequency regions. First, the characteristics of the circuit will be examined for frequencies less than the h_{fe} cutoff frequency of the transistor. Then, its high frequency characteristics will be determined.

Results of measurements made on the circuit to obtain verification of the analysis will then be presented.

2. Analysis

a. Low Frequency

At low frequencies, the circuit may be represented by the equivalent circuit shown in figure III-2, where

$$h_{22} = \frac{L_c}{V_{cb}} \left| i_e = 0; \quad h_{11} = \frac{V_{eb}}{L_e} \left| v_{cb} = 0; \quad h_{12} = \frac{L_c}{L_b} \left| v_{cb} = 0 \right. \right.$$

In this equivalent circuit, the voltage feedback ratio ($h_{rb} = v_{eb}/v_{cb}$) has been neglected and a resistive load has been assumed. A calculation for $(E_o/E_i)(s)$ (See Appendix III-A) gives the result shown below.

$$\frac{E_o}{E_i}(s) = \frac{\frac{R_L}{R_L' R' C}}{s + \frac{R_L' + R'(1-h_{12})}{R' R_L' C}} \quad (\text{III-1})$$

where

$$R_L' = h_{11} + R_L, \quad R' = \frac{R}{1 + h_{22}R}$$

Upon examining this equation, one can see that the same transfer function can be obtained from the circuit shown in figure III-3. Thus, for a resistive load, the transistor acts as an inductor in series with a resistor. The cutoff frequency for this circuit is:

$$f_c = \frac{R_L' + R'(1 - h_{12})}{R_L' R' C} \quad (\text{III-2})$$

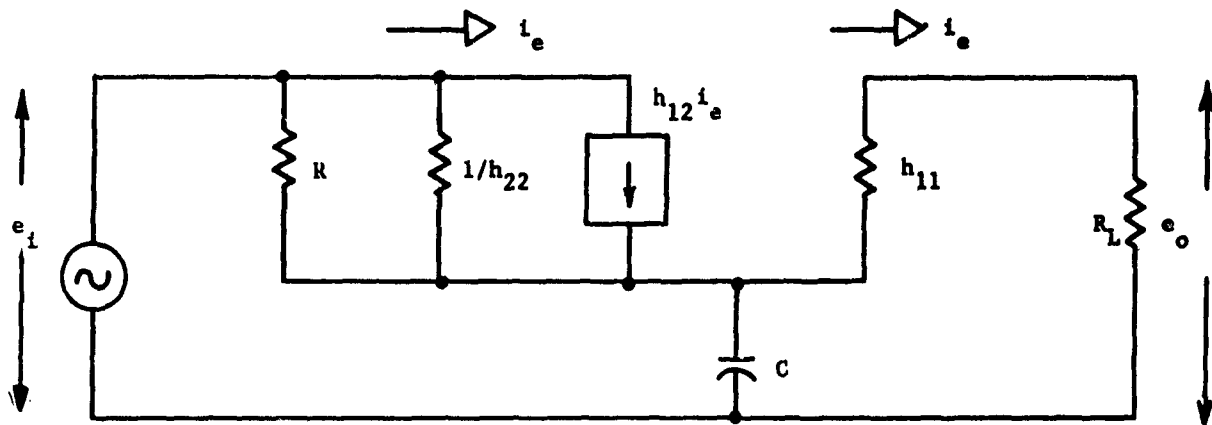

Figure III-2. Low Frequency Equivalent Circuit Diagram of Figure III-1

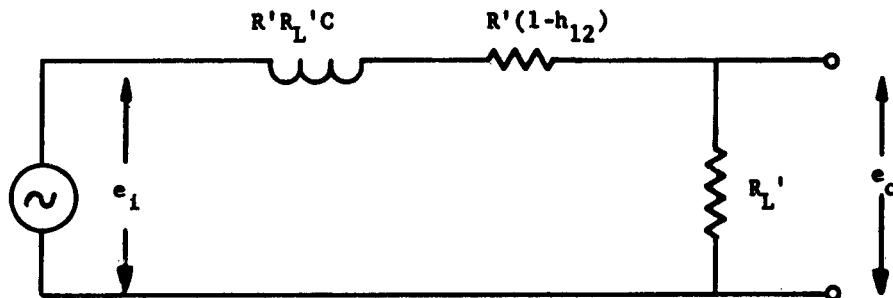

Figure III-3. A Circuit with the Same Transfer Function as Figure III-1 and Figure III-2.

The maximum attenuation that can be obtained from this configuration is limited by: (1) the feedback voltage ratio, h_{21} (this quantity was neglected in the analysis); (2) the beta cutoff frequency of the transistor; and (3) the parasitic resistance and inductance of the capacitor used.

The effect of h_{21} can be better understood if its nature is examined. At low frequencies, a voltage feed back of the collector-base voltage to the base-emitter junction is caused by a modulation of the base resistance by the collector-base AC voltage. At high frequencies, the collector-emitter capacity of the transistor is the dominant cause of this voltage feedback. The ability of a capacitor, which is placed from the base terminal of the transistor to ground, to reduce this feedback is seriously hampered by the base resistance. This effect can be seen by examination of the equivalent T-circuit used for the transistor. This is shown in figure III-4, where r_b is shown as a variable resistor to indicate that it is modulated by the collector voltage. Examination of this circuit, shows that C does very little to reduce the feedback.

b. High Frequency

At high frequencies, the hybrid parameter equivalent circuit is inadequate. The broadband equivalent circuit is shown in figure III-5^(III-1).

Since a general analysis of this complex equivalent circuit would be difficult, the first part of the analysis shown in Appendix III-B, contains a step-by-step simplification of it. To accomplish this simplification: (1) the parameters of a specific transistor, the 2N404, were measured or obtained from data sheets, (2) a specific frequency, 1 Mc/s, was chosen and the impedances were calculated at this frequency; and, (3) the negligible quantities were eliminated from the equivalent circuit.

Figure III-6 is a diagram of the simplified equivalent circuit of the transistor. When the external resistors and capacitors are added to the equivalent transistor circuit of figure III-6, the equivalent circuit of the ripple clipper can be drawn as shown in figure III-7.

(III-1) Hurley, Richard B., "Junction Transistor Electronics", Wiley, p. 246.

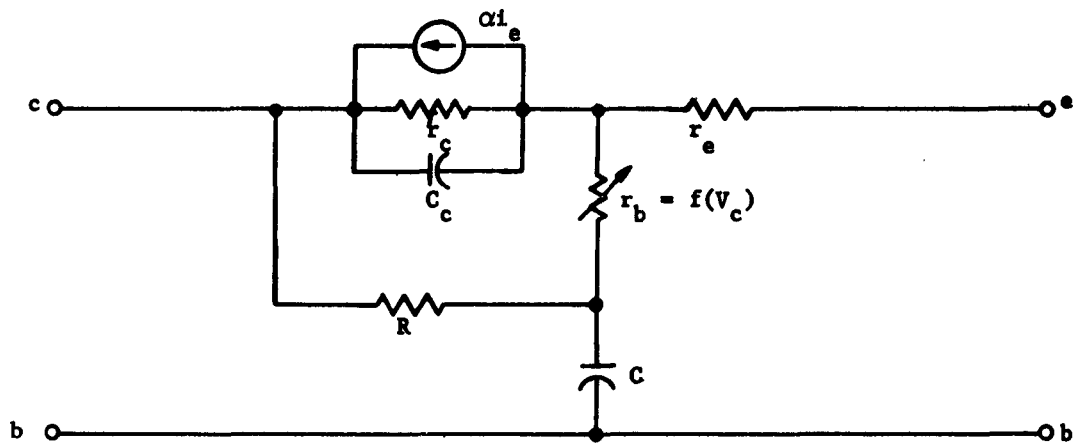

Figure III-4. High Frequency Equivalent Circuit Diagram of Figure III-1.

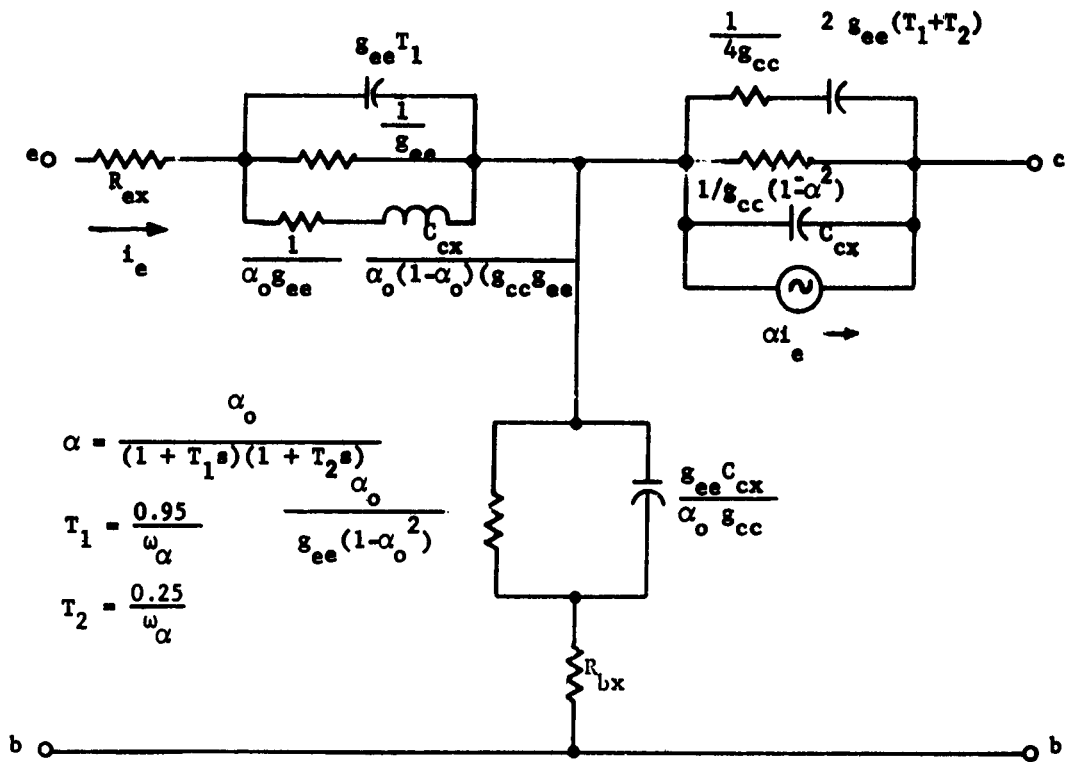

Figure III-5. Broadband Equivalent Circuit Diagram of Figure III-1

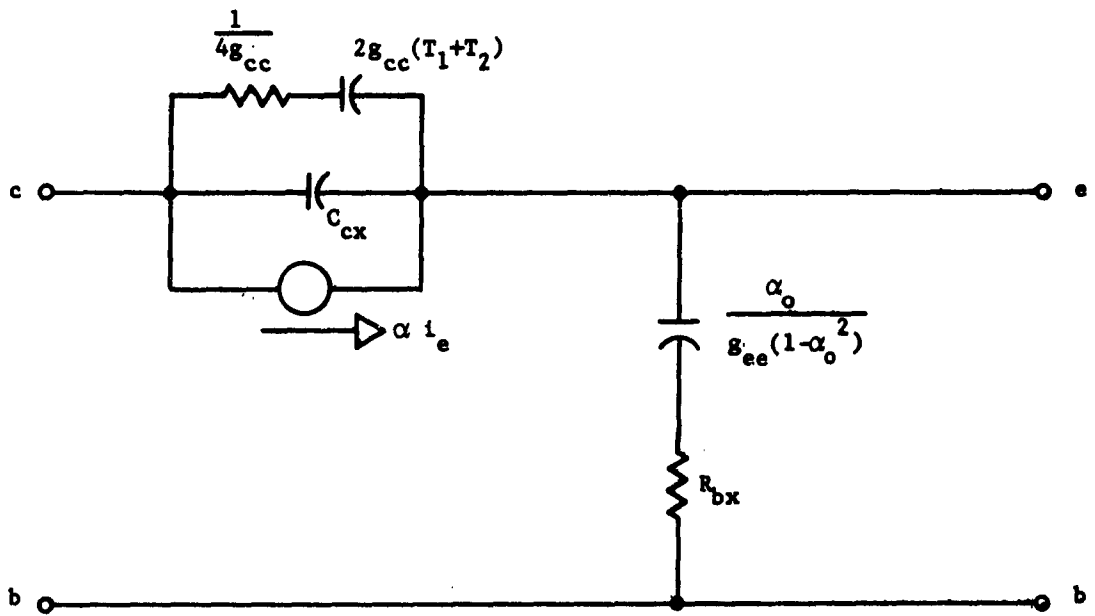

Figure III-6. Simplified Equivalent Circuit Diagram of Transistor

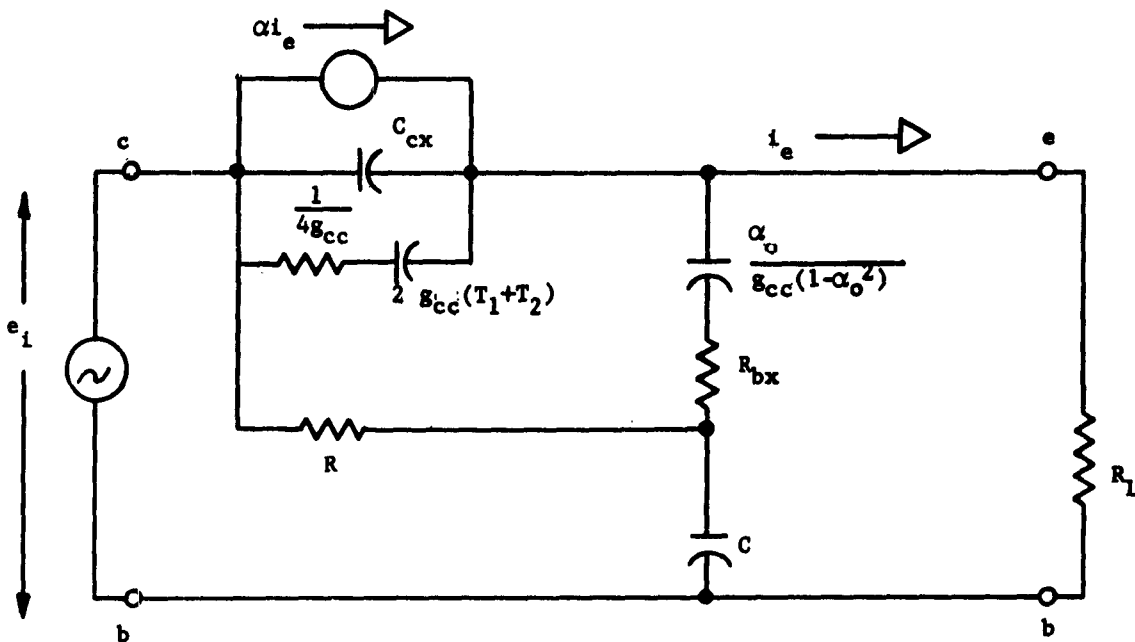

Figure III-7. Simplified High Frequency Equivalent Circuit Diagram of Figure III-1

From this circuit, it is obvious that the transistor will not behave as an inductance at the higher frequencies. In fact, the impedance of the transistor will be decreasing, rather than increasing, with frequency.

At low frequencies much of the base current is shunted to ground through C. At high frequencies, the signal current can now bypass its previous path to the base through R by going through the collector capacity, C_{cx} , and the diffusion capacity, $2g_{cc}(T_1 + T_2)$. Consequently, the frequency at which the collector to base impedance of the transistor becomes comparable to R is the frequency at which the impedance of the transistor will begin to decrease with frequency instead of increase.

3. Test Results

Tests were conducted to verify the conclusions of the analysis. A 2N404 transistor was selected because measurements could be easily obtained with it.

First, some of the transistor parameters were measured. Figure III-8 is a plot of h_{fe} versus frequency for the 2N404 selected; ($h_{fe} = \frac{c}{L_b} \Big|_{V_{ee} = 0}$). Figure III-9 is a plot of the collector to base junction capacity versus collector voltage. The short circuit, common emitter, input impedance (h_{ie}) was measured to be 450 ohms. The short, common emitter, output admittance, (h_{oe}) and the base spreading resistance (r_b) were obtained from the manufacturer's data sheet ($h_{ob} = 400$ mhos, $r_b = 100$ ohms). Using this data, a plot of attenuation (E_2/E_1) versus frequency for the circuit of figure III-10 was calculated using values for C of 0.082 μ f, 0.003 μ f and 0.0061 μ f.

Then attenuation was measured as a function of frequency. The results are shown in figure III-11.

A solution, presented in Appendix III-B for the ratio of e_o/e_i at 1 Mc/s, gives a value of 0.024. The measured value is 0.021. The curves merge at 1 Mc/s because the majority of the base current is flowing through the collector capacity, C_{cx} , rather than through R. Consequently, C has little effect upon the characteristics at this frequency.

At 500 Kc/s, the impedance of the collector capacity is 10,000 ohms. Since this impedance is comparable to R (8k Ω) the impedance of the transistor begins to decrease as shown in figure III-11.

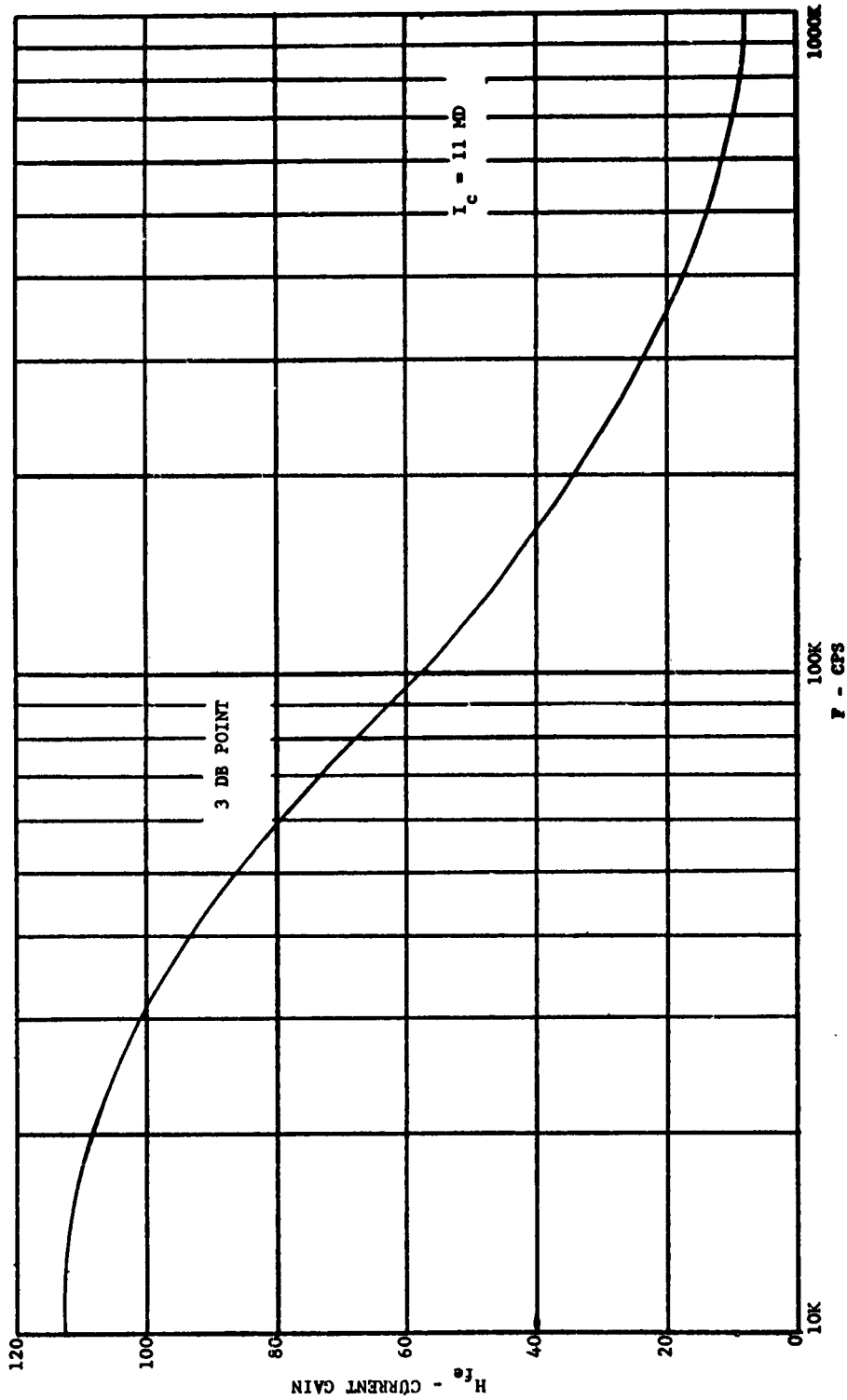

Figure III-8 H_{fe} vs. Frequency for 2N404

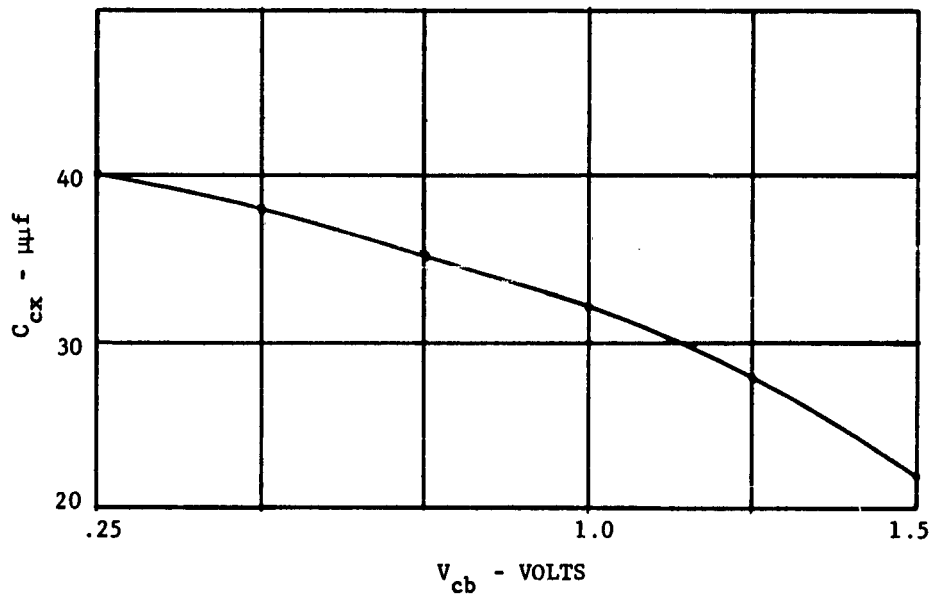
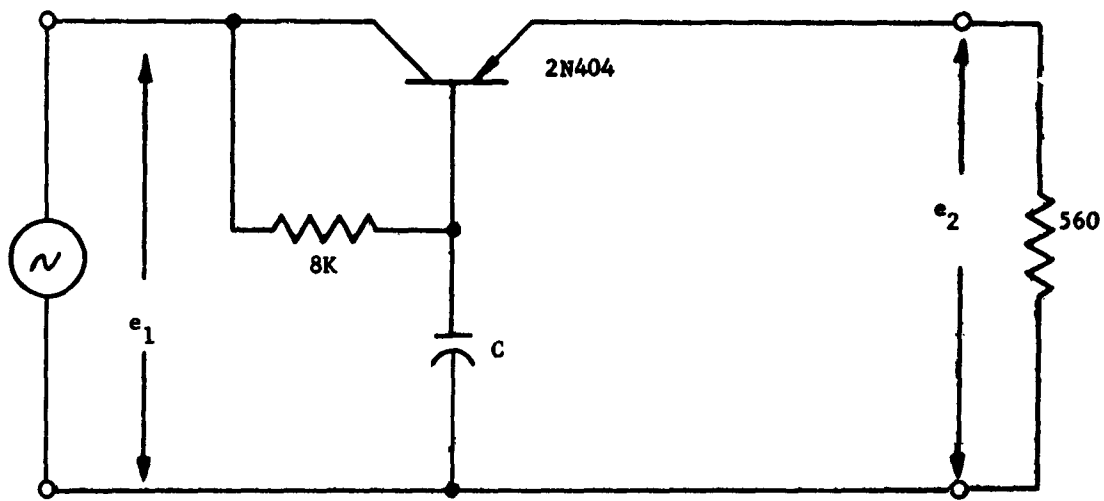

Figure III-9 Collector Capacity vs. Voltage for 2N404 Transistor



D.C. Biasing Not Shown

Figure III-10 AC Test Circuit

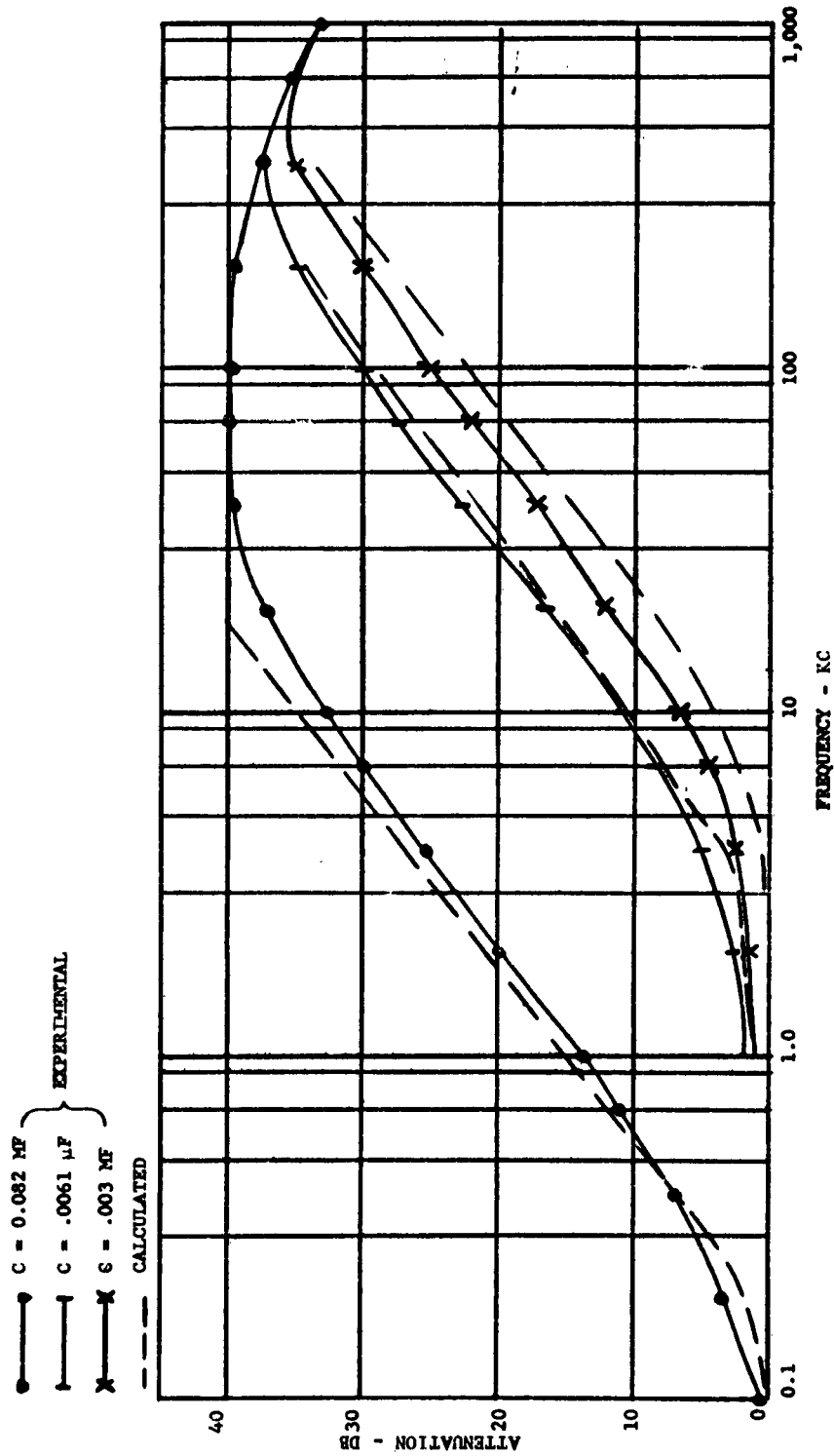

Figure III-11 Attenuation vs. Frequency for 2N404 Transistor Filter

4. Summary

The transistor filter analyzed should find application at low frequencies where the coil size required for conventional filters is prohibitive. The frequency range of the filter is limited by the parasitic resistance and inductance of the capacitor used, and the h_{fe} cutoff frequency and voltage feedback ratio, h_{21} , of the transistor. The design procedure is simple and accuracy is excellent.

C. ACTIVE FILTER NETWORKS

1. Requirements

Design specifications for this active filter were chosen with the idea that the filter developed might be used on the DC supply line of a military aircraft. These specifications are listed below:

DC Input	27 to 32 volts
Current	1 ampere
Temperature	-30°C to 85°C
Insertion loss	Greater than 60 db from 100 cps to 100 Kc/s.

The filter is to be both as small and as light as possible. Without this last requirement, there would be no need to use an active filter, since a standard L-C filter could be used to meet the specification.

2. Circuits Tested

The first configuration tried is shown in figure III-12.

This circuit gave 20 db of attenuation when terminated in a 50-ohm AC load and carrying one ampere DC. With Q_3 removed, the attenuation remained the same. Since Q_2 and Q_3 , the current amplifiers for the feedback loop, are being driven from a low impedance source, the collector current of Q_2 will be directly proportional to the input impedance of the current amplifiers. By removing Q_3 , the current gain decreased by a factor of H_{FE} , but the input impedance decreased by the same factor. Consequently, the collector current of Q_2 remains approximately the same and the attenuation characteristics of the circuit remain the same.

Also, it was found that the insertion loss is greater if C_2 is placed in parallel with C_1 . It was expected that placing C_2 from the collector to

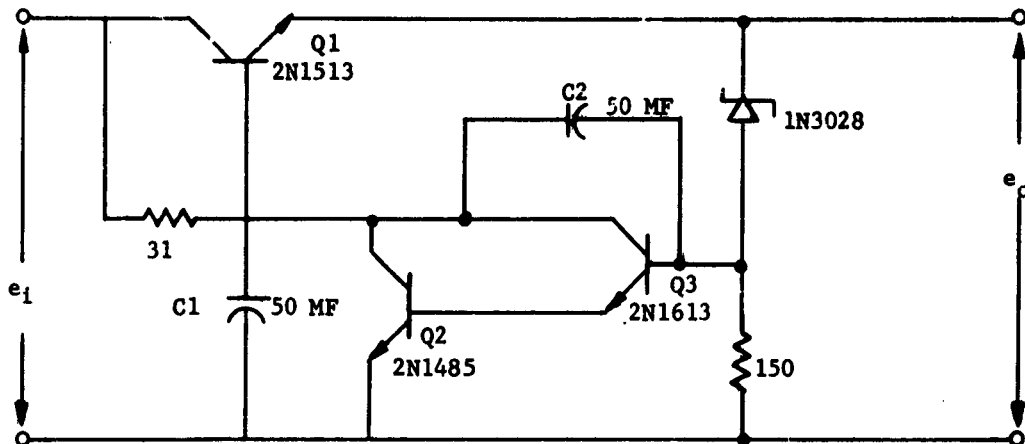

Figure III-12 Circuit of an Active Filter

the base of Q_3 would make C_2 appear many times greater than it actually is. However, the input resistance at the base terminal of Q_3 is too high. Thus, most of the capacitor current is shunted to ground through R_2 , giving C_2 limited effectiveness.

The circuit shown in figure III-13 was next used in order to increase the value of R_1 . The attenuation characteristics of this circuit are shown in figure III-14. An analysis of these filtering characteristics is contained in Appendix III-C. To simplify the analysis, calculations are made at 40 cps where the 50 μ f tantalum capacitors may be neglected. An approximate expression for e_{out}/e_{in} is developed which holds for low frequencies.

$$\frac{e_{out}}{e_{in}} = \frac{R_y}{R_i + R_y} \quad (\text{III-3})$$

where

$$R_y = \frac{(h_{ibi} + R_x) (R_2 + R_{in}) (R_L + R_x)}{h_{fe3} (R_2 R_L)} \quad (\text{III-4})$$

Another configuration tried is shown in figure III-15. The attenuation characteristics of this circuit are shown in figure III-16. Comparison of the results of this circuit to those of the circuit of figure III-13 shows that the circuit of figure III-13 gives 20 db more attenuation than the circuit of figure III-15. If figure III-13 is examined carefully, it could be seen why this is so. The input resistance, as seen at the base of Q_3 , is greater than that of the circuit of figure III-15, by a factor of $h_{fe3} R_d$ because of the Zener diode in the emitter circuit of Q_3 , where R_d is the dynamic resistance of the Zener diode. In addition, the divider network composed of R_2 , R_3 , and R_4 attenuates the signal being fed back more than the Zener diode and resistor combination of figure III-13. However, this circuit enables one to add gain more easily to the feedback loop. With this in mind, the three configurations shown in figure III-17 were tried. Figure III-18 is a plot of the attenuation characteristics of each of these circuits with a DC input at 30 volts.

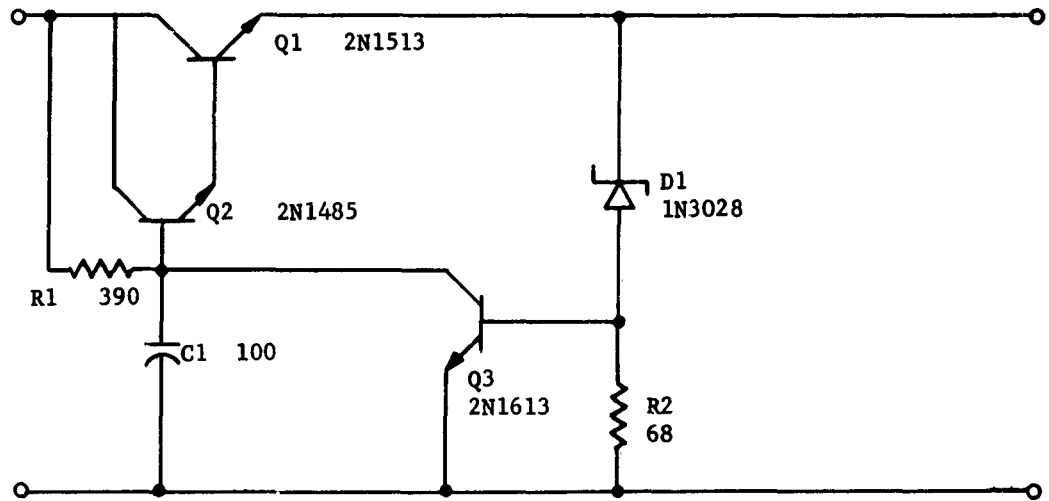

Figure III-13 Circuit Using Larger Value of R1

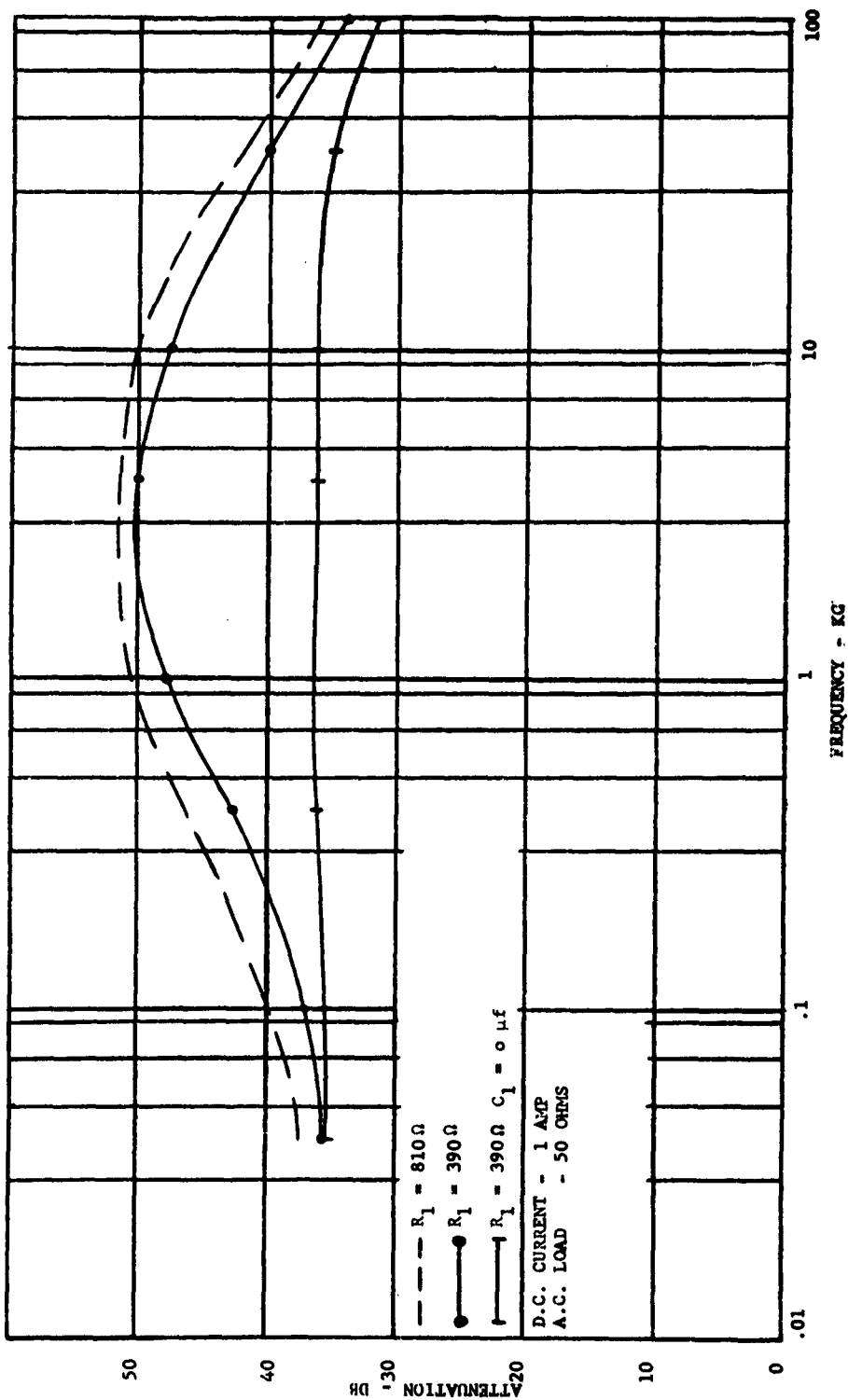

Figure III-14 Attenuation vs. Frequency for Circuit of Figure III-5

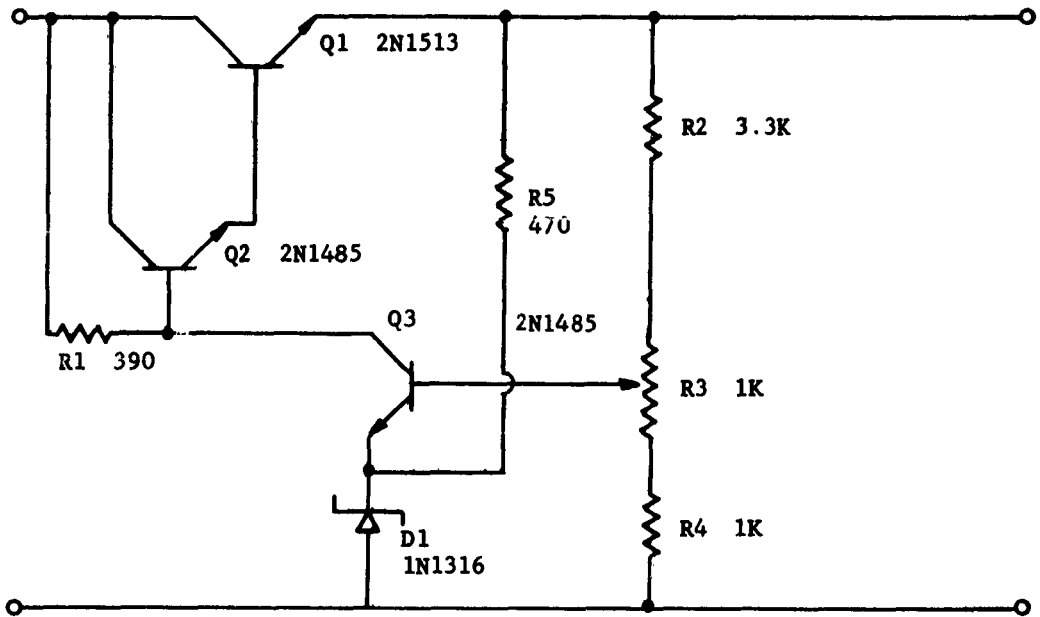

Figure III-15 Circuit Using Voltage Divider Input

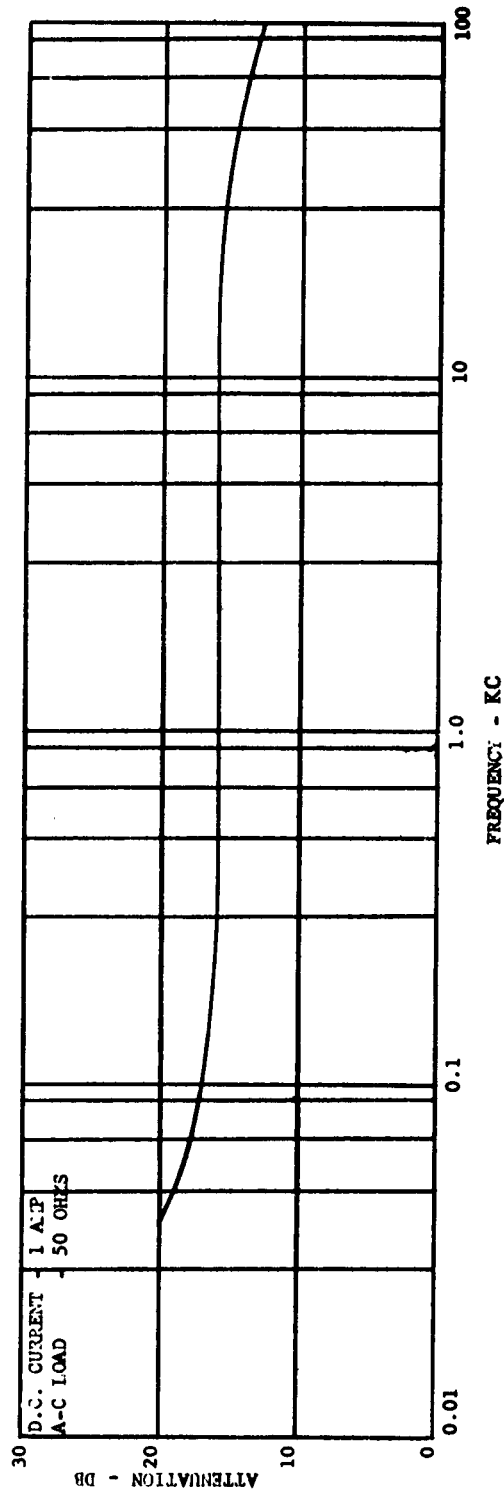

Figure III-16 Attenuation vs. Frequency for Circuit of Figure III-7

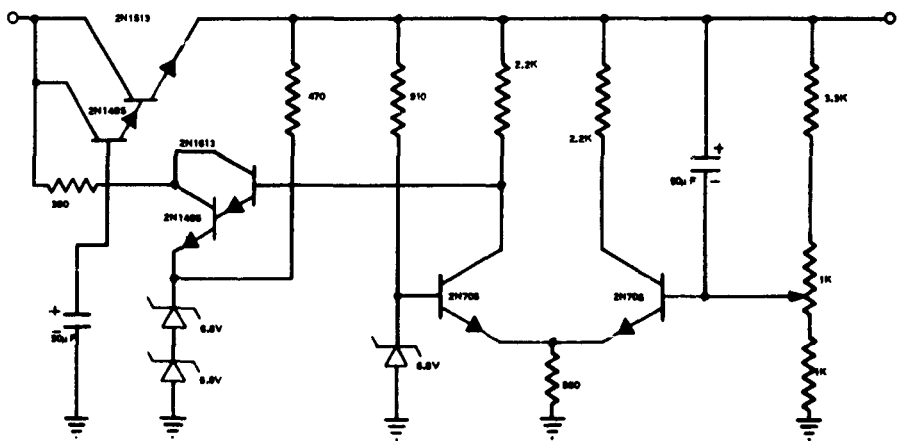
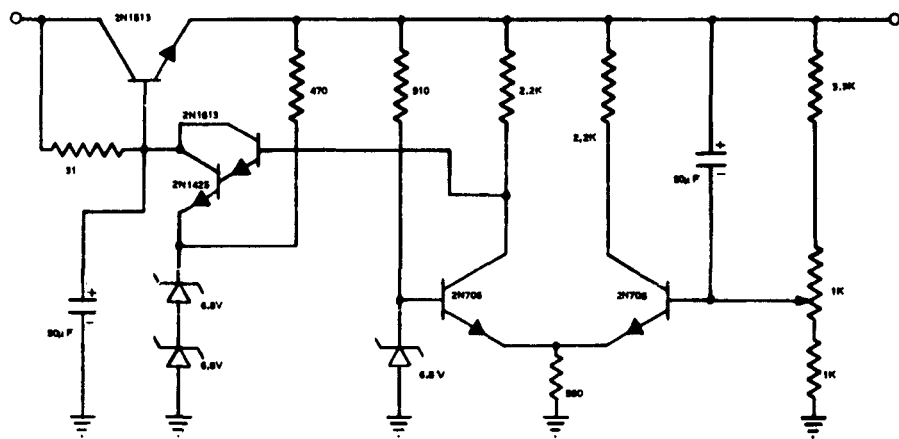
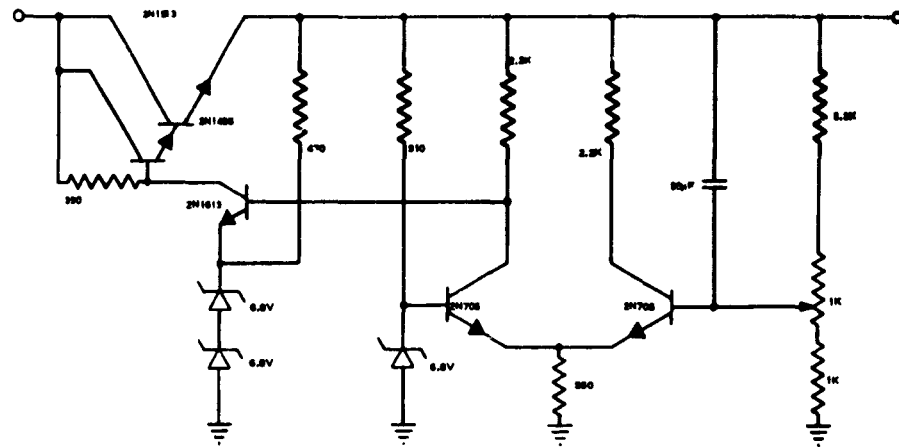

Figure III-17 Three Forms of an Experimental Active Element Filter

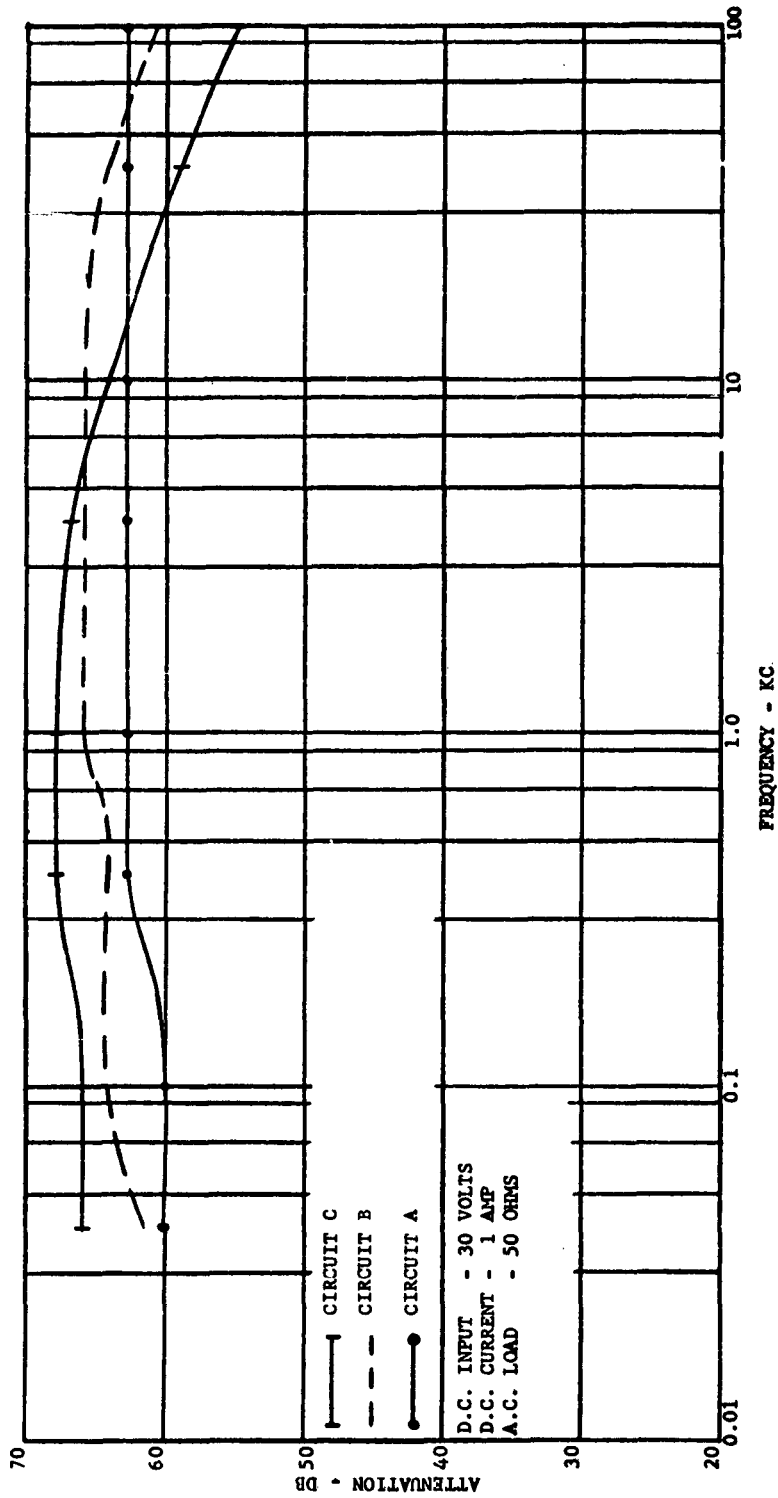

Figure III-18 Experimental Active Filter Frequency Attenuation Curves

3. Comparison of Results

Circuits A and C of figure III-17 require 27 volts AC input to obtain 24 volts output. Circuit B (figure III-17) requires 26 volts DC input to obtain 24 volts output. Circuit C (figure III-17) gives the greatest attenuation at the low frequencies, but it requires six transistors. Circuit B (figure III-17) requires only five transistors and gives almost equal attenuation.

Figure III-19 is a plot of the attenuation characteristics for circuit C (figure III-17) for three different DC input voltages. Figure III-20 is a plot of the attenuation characteristics for circuit B (figure III-17) for three different DC input voltages. Figure III-21 is a plot of the output resistance of circuit B (figure III-17) versus frequency. An analysis of circuit B (figure III-17) is contained in Appendix III-D.

4. Summary

A series regulator is a very effective filter for low frequencies. Its useful frequency range is limited by the frequency response of the transistors used. If a DC insertion loss larger than two or three volts can be tolerated, the performance can be significantly improved. The temperature dependence of this circuit was not studied. This should be the next step in the investigation. If the temperature variation of the transistor parameters is known, it should be possible to use the analysis presented in this paper to predict the temperature variation of circuits characteristics.

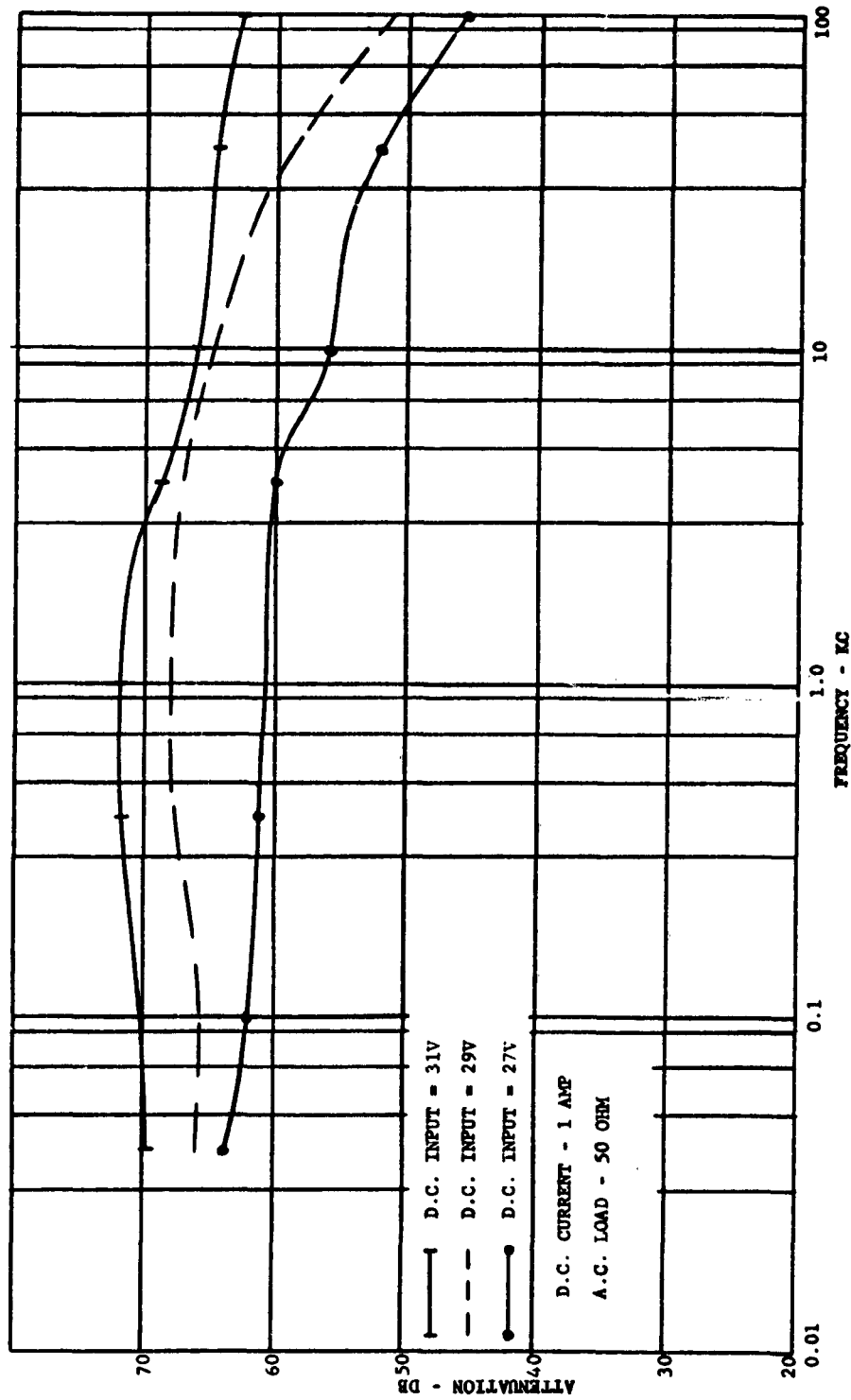

Figure III-19 Attenuation vs. Frequency for Circuit C of Figure III-17

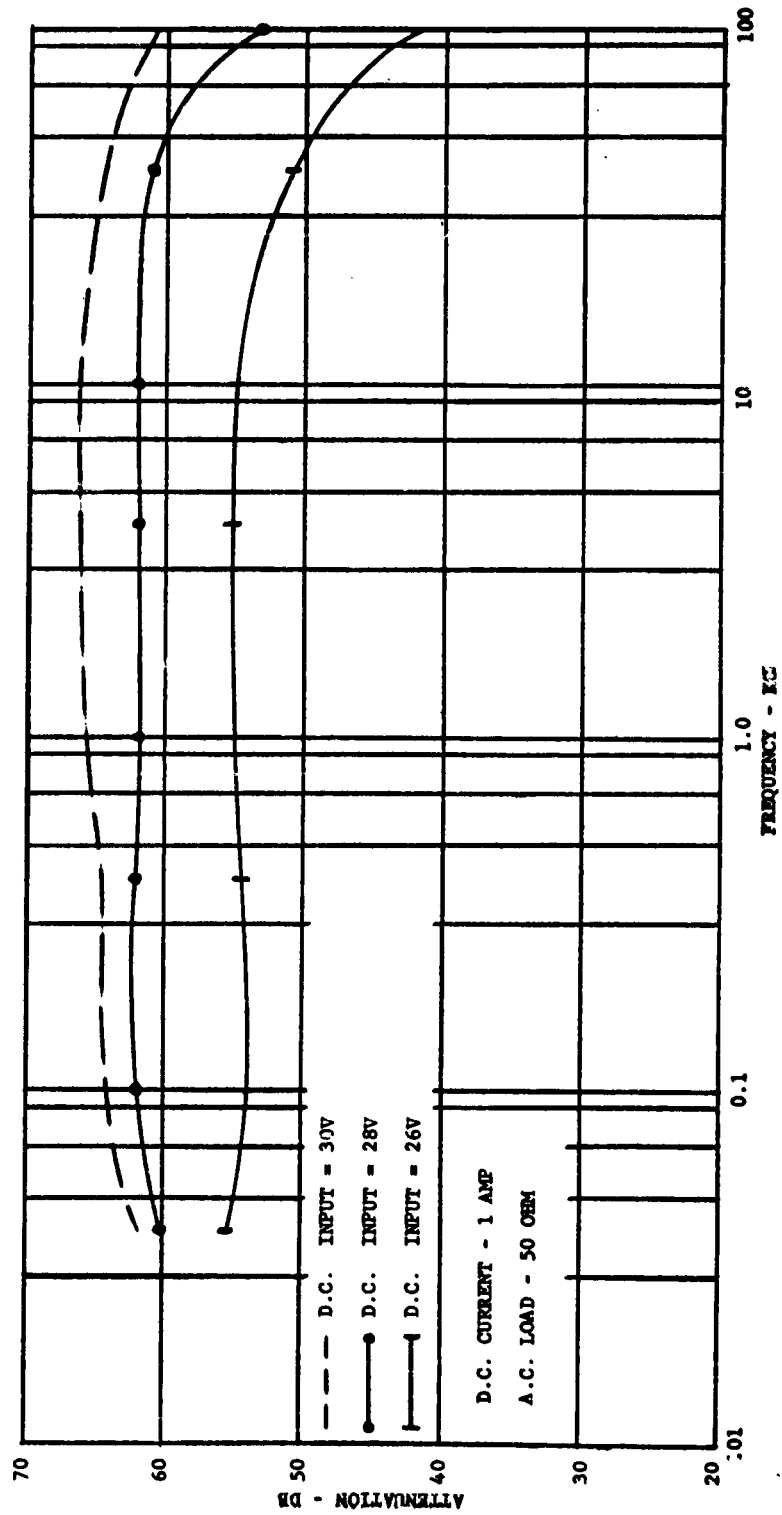

Figure III-20 Attenuation vs. Frequency for Circuit B of Figure III-17

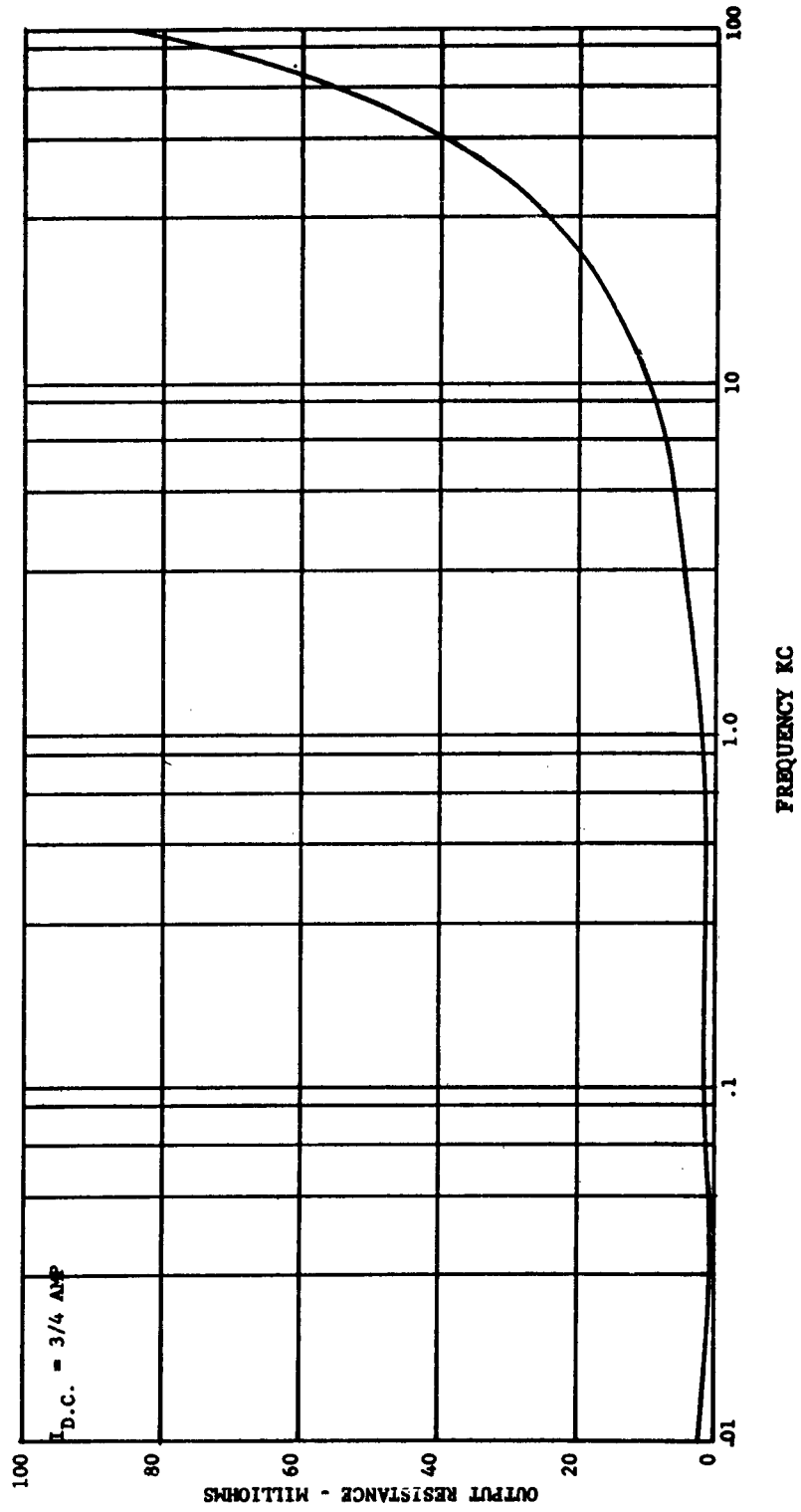

Figure III-21 Output Resistance vs. Frequency for Circuit B

APPENDIX III-A

LOW FREQUENCY CALCULATION OF E_o/E_i FOR RIPPLE CIRCUIT CLIPPER

This appendix presents calculations related to figures III-1 and III-2.

Examining the equivalent circuit diagram of figure III-2, we may combine some quantities. Thus,

$$R' = \frac{R}{R + \frac{1}{h_{22}}} = \frac{R}{1 + h_{22}R}, \quad \text{and} \quad \text{(III-A-1)}$$

$$R'_L = h_{11} + R_L \quad \text{(III-A-2)}$$

The circuit may now be redrawn as in figure III-A-1, and the following expressions written.

$$E_i(s) = \left[-h_{12} R' - \frac{1}{SC} \right] I_e(s) + \left[R' + \frac{1}{SC} \right] I_c(s) \quad \text{(III-A-3)}$$

$$0 = \left[R'_L + \frac{1}{SC} \right] I_e(s) - \frac{1}{SC} I_c(s) \quad \text{(III-A-4)}$$

Solving for I_e ,

$$I_e = \frac{\begin{vmatrix} E_L R' + \frac{1}{SC} \\ 0 & -\frac{1}{SC} \end{vmatrix}}{\begin{vmatrix} -h_{12} R' - \frac{1}{SC} & R' + \frac{1}{SC} \\ R'_L + \frac{1}{SC} & -\frac{1}{SC} \end{vmatrix}} = \frac{-E_i/SC}{\frac{1}{SC} (h_{12} R' + \frac{1}{SC}) - (R'_L + \frac{1}{SC})(R' + \frac{1}{SC})}$$

$$= \frac{E_i}{(SR'_L C + 1)(R' + \frac{1}{SC}) - (h_{12} R' + \frac{1}{SC})}$$

$$= \frac{E_i}{SC R' R'_L + R' + R'_L - h_{12} R'} \quad \text{(III-A-5)}$$

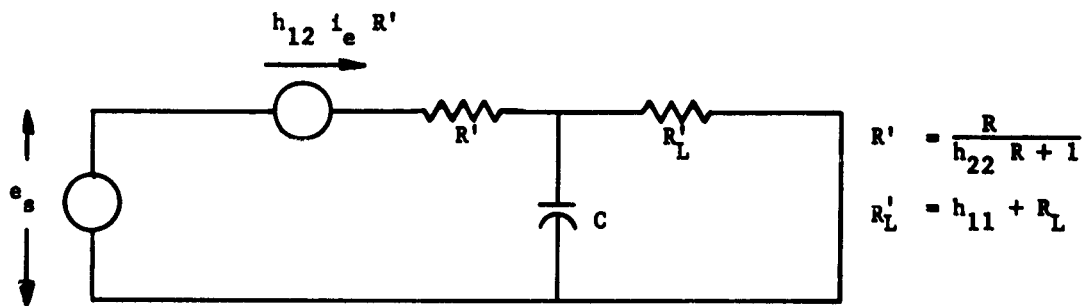

Figure III-A-1 Simplified and Combined Equivalent Circuit Diagram

$$I_e = \frac{E_i}{R'_L R'_L C} \frac{1}{s + \frac{R'_L + R' (1 - h_{12})}{R'_L R'_L C}} \quad (\text{III-A-6})$$

$$E_o = I_e R_L$$

$$\frac{E_o}{E_i} = \frac{\frac{R_L}{R'_L R'_L C}}{s + \frac{R'_L + R' (1 - h_{12})}{R'_L R'_L C}} \quad (\text{III-A-7})$$

APPENDIX III-B

HIGH FREQUENCY CALCULATION OF E_o/E_i FOR
RIPPLE CLIPPER CIRCUIT^o

A. CALCULATION OF 1 Mc/s ATTENUATION

Examining the complete equivalent circuit diagram, figure III-B-1, we find the first problem is to determine values for the various elements shown. Starting with the known values:

$$R_L = 560 \text{ ohms}, R = 8000 \text{ ohms}, C = .086 \mu\text{f}.$$

$$\alpha_o = .99 @ I = 10 \text{ ma.}, V_{ce} = 1 \text{ volt and}$$

$$C_{ox} = 26 \text{ pf @ 10 ma and 1 volt.}$$

$$g_{ee} = \frac{8I_e}{KT} = \frac{10 \times 10^{-3}}{.026} = .39 \text{ mhos.}$$

$$\frac{1}{\alpha_o g_{ee}} = \frac{2.6}{0.99} = 2.62 \text{ Ohms}$$

$$g_{ee} T_1 = g_{ee} \frac{0.95}{\omega \alpha} = .039 \frac{.95}{2\pi(6 \times 10^6)} = .001 \mu\text{f}$$

$$g_{ee} = \frac{1}{h_{cb}(1-\alpha_o^2)} = \frac{400 \cdot 10^{-6}}{100(1-0.98)} = 200 \cdot 10^{-6}$$

$$\frac{C_{cx}}{\alpha_o(1-\alpha_o)(g_{ee}g_{cc})} = \frac{26 \cdot 10^{-12}}{0.99(.01)(0.39 \cdot 2 \times 10^{-4})} = 34 \mu\text{h}$$

$$\frac{1}{4g_{ee}} = \frac{1}{8 \times 10^{-4}} = 1.25 \cdot 10^3 = 1250 \text{ ohms.}$$

$$2g_{cc} = \frac{(0.95 + 0.25)}{\omega \alpha} = \frac{(2)(2)(10^{-4})(1.2)}{2\pi(.6 \times 10^{-6})} = 12.7 \text{ pf}$$

$$\frac{\alpha_o}{g_{ee}(1-\alpha_o^2)} = \frac{0.99(2.6)}{0.02} = 130 \text{ ohms}$$

$$\frac{g_{cc} C_{cx}}{\alpha_o g_{cc}} = \frac{0.39(2.6 \times 10^{-4})}{0.99(2 \times 10^{-4})} = .051 \mu\text{f}$$

$$R_{bx} = 100 \text{ ohms}$$

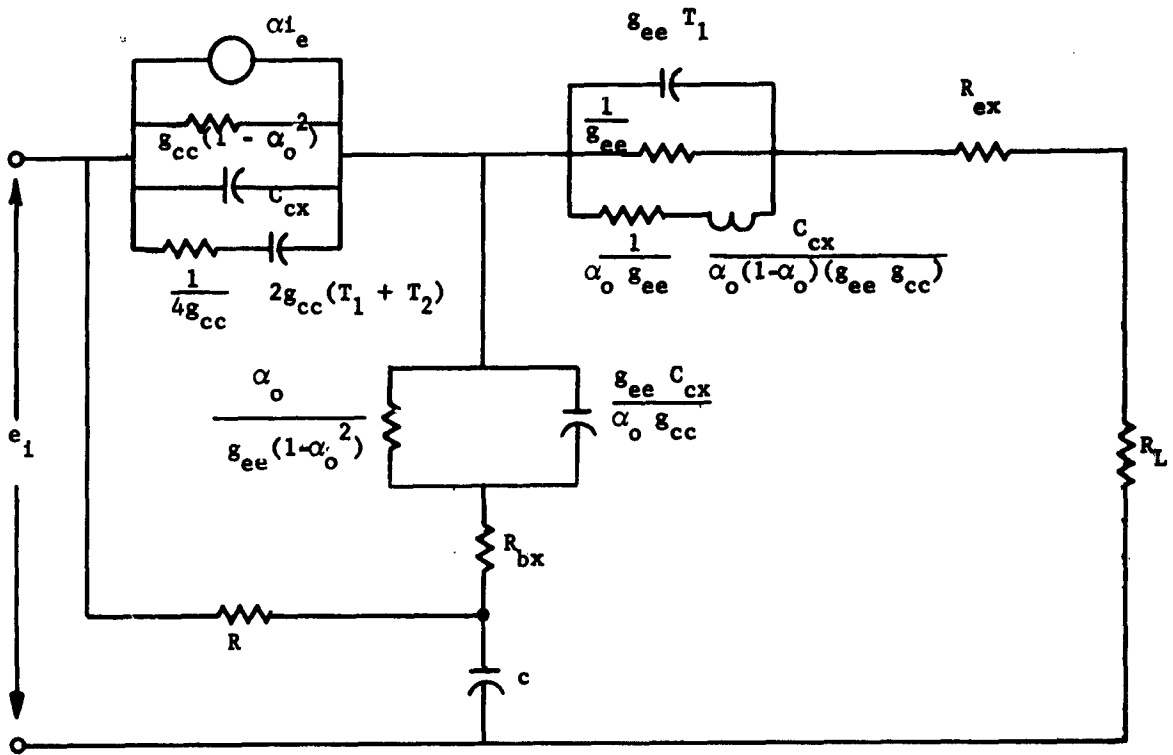

Figure III-B-1. Complete Equivalent Circuit Diagram

$$\frac{1}{g_{cc}(1-\alpha_o^2)} = \frac{r_{cb}(1-\alpha_o^2)}{(1-\alpha_o^2)} = 2.5 \times 10^5 \text{ ohms}$$

At this point, the complete equivalent circuit appears as shown in figure III-B-2, and simplification is required to reduce the complexity of the calculations.

B. SIMPLIFICATION OF THE EQUIVALENT CIRCUIT

At a frequency of one megacycle, all impedances in the emitter leg are small compared to 560 ohms and may be neglected.

In the base leg, the 130-ohm resistor is shunted by a 3-ohm reactance, and may be neglected. The 8-kilohm resistor is effectively shunting the circuit, since one end is grounded by the 0.1 μ f capacitor. Therefore it can be neglected.

The series combination of 1250 ohms and 13 pf may be converted to a parallel combination of 126 k Ω and 13 pf.

The circuit thus simplifies to that shown in figure III-B-3. Combining the .1 μ f and .051 μ f series capacitors to a simple equivalent of .03 μ f, it may be redrawn as shown in figure III-B-4.

From the plot of figure III-8, h_{fe} is found to be 9. Since $\alpha \approx \frac{|h_{fe}|}{1 + |h_{fe}|}$, $|\alpha| = 0.9$. In the calculations to follow, the phase of α is assumed to be zero. Since the alpha cutoff frequency is about 6 Mc/s, this assumption should not greatly affect the accuracy of the results. The current generator, α_{ie} , and the 39 pf capacitor may be transformed into an equivalent voltage source. (See figure III-B-5).

$$\text{Then } i_e = \frac{(E_{in} - g_{3900} i_e) (100 - g_{4.5})}{(100 - g_{4080}) (660 - g_{4.5}) - (100 - g_{4.5})^2}$$

$$i_e = g \frac{E_{in}}{26900 (1-0.145)}$$

$$\frac{E_{out}}{E_{in}} = \frac{|i_e| 560}{E_{in}} = \frac{560}{2690 (0.85)}$$

$$= .024$$

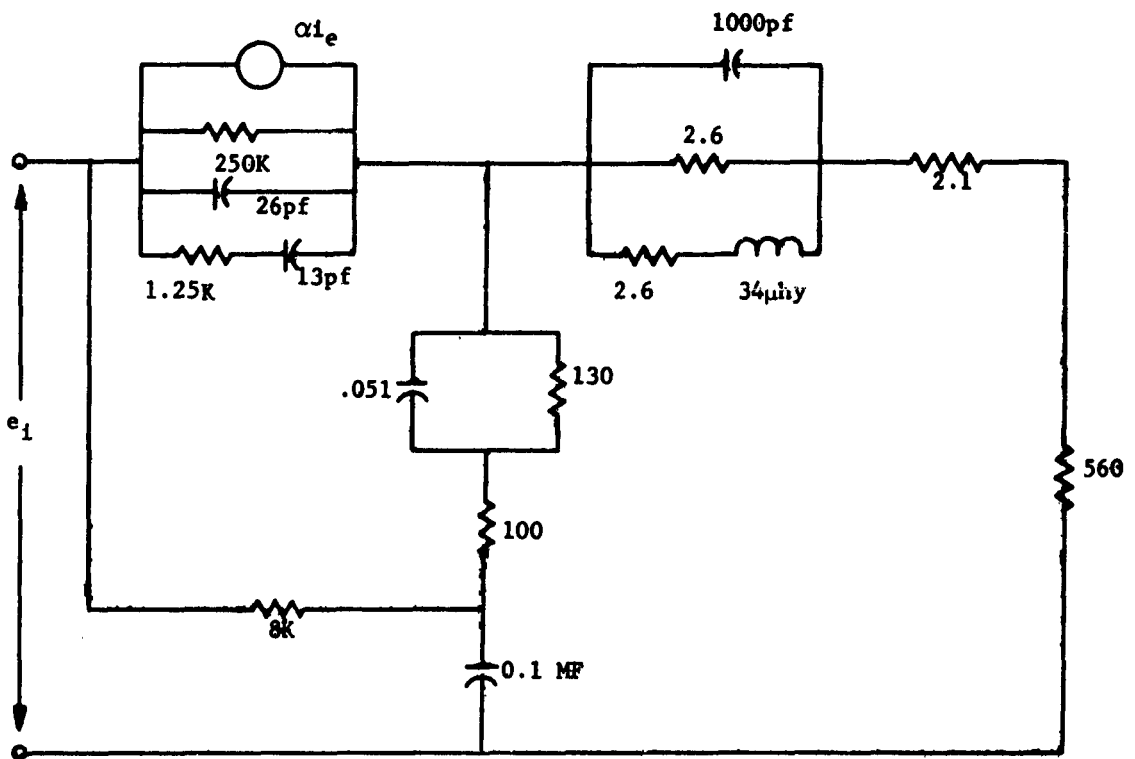

Figure III-B-2. Equivalent Circuit Diagram with Numerical Values

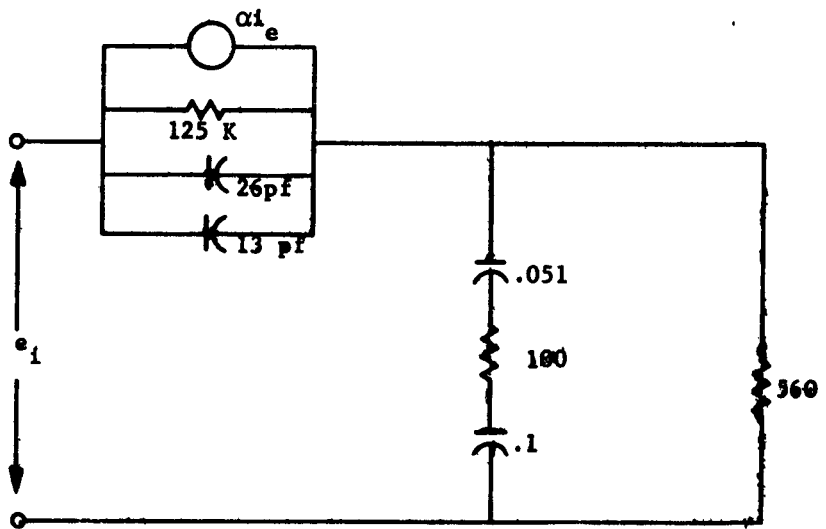

Figure III-B-3 Circuit of Figure A-3 Simplified

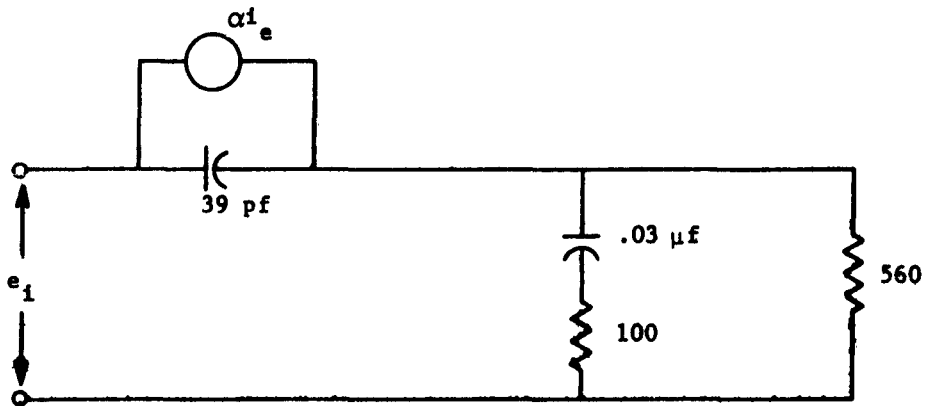

Figure III-B-4. Circuit of Figure III-B-2 Further Simplified

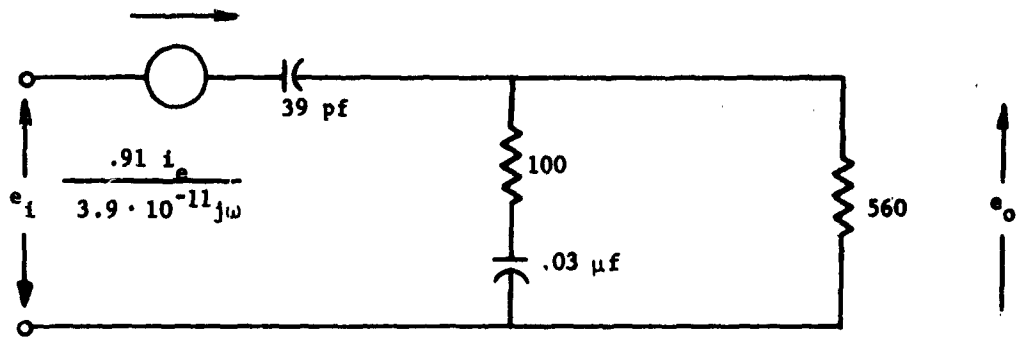

Figure III-B-5. Circuit of Figure III-B-4 with the Current Source Modified to Equivalent Voltage Source

APPENDIX III-C

ANALYSIS OF THREE TRANSISTOR ACTIVE FILTER NETWORK

This Section presents an analysis of the circuit shown in figure III-13.

This analysis follows the outline presented by Hurley in "Junction Transistor Electronics". The circuit is analyzed on the assumptions of linear circuits, and the validity of superposition.

In the circuit of figure III-C-1, e_2 is assumed to be zero, and the circuit is analyzed for the currents produced by e_1 . Then e_1 is assumed to be zero, and the circuit analyzed for the currents due to e_2 . The two circuit solutions are added to find the actual current flow.

When the magnitudes of the currents produced by e_1 and e_2 are compared, it is seen that the currents produced by e_1 are negligible in comparison to those produced by e_2 . Consequently, only the currents caused by e_2 need be evidenced.

In the circuit of figure III-C-2,

$$i_T = i + i \left[\frac{(h_{fe1} + 1) (h_{fe2} + 1) (h_{fe3}) R_2 R_L}{(R_2 + R_{in}) (R_L + R_x)} \right] \quad (\text{III-C-1})$$

$$v = i_T R_y = (h_{fe2} + 1) \left\{ h_{ib2} + [(h_{fe1} + 1) (h_{ib1} + R_x)] \right\} \quad (\text{III-C-2})$$

$$R_y = \frac{v}{i_T} = \frac{(h_{fe2} + 1) \left\{ h_{ib2} + [(h_{fe1} + 1) (h_{ib1} + R_x)] \right\}}{1 + \frac{(h_{fe2} + 1) (h_{fe2} + 1) (h_{fe3}) R_2 R_L}{(R_2 + R_{in}) (R_L + R_x)}} \quad (\text{III-C-3})$$

With the assumptions:

$$h_{fe1} \gg 1, h_{fe2} \gg 1,$$

$$(h_{fe4} + 1) (h_{ib1} + R_0) \gg h_{ib2}$$

$$\frac{h_{fe1} h_{fe2} h_{fe3} R_2 R_L}{(R_2 + R_{in}) (R_L + R_x)} \gg 1$$

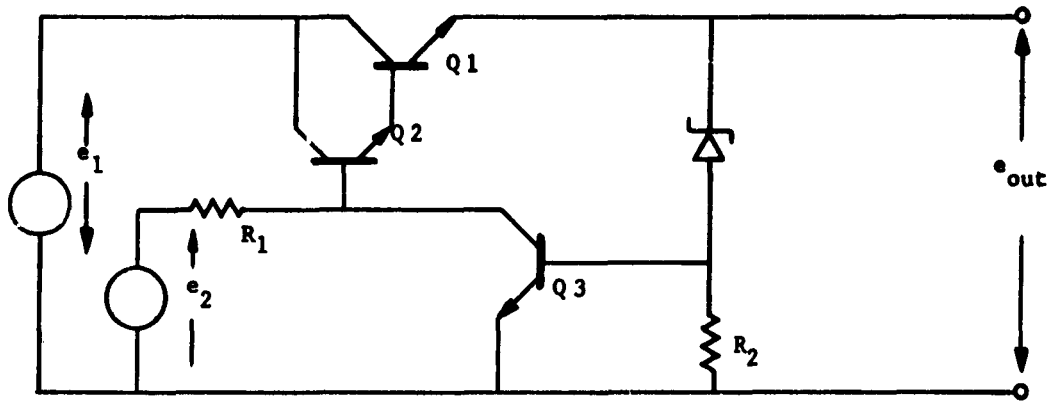

Figure III-C-1. Equivalent Circuit for Figure III-5

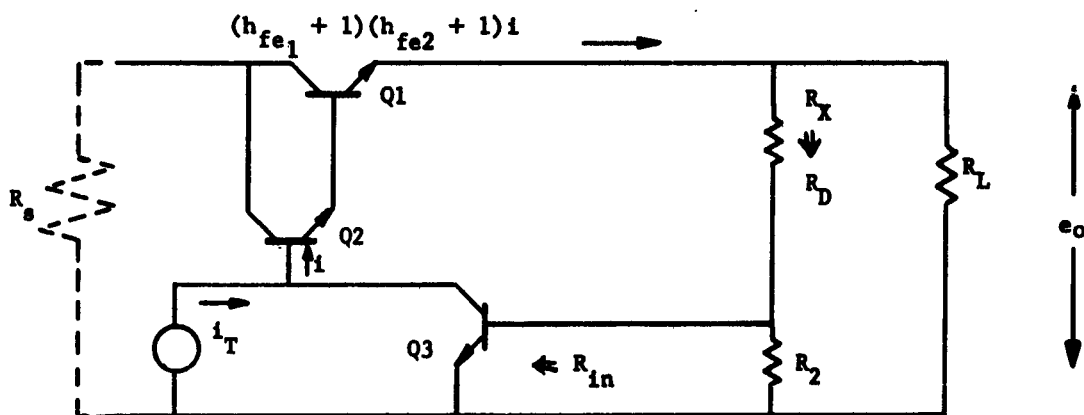

Figure III-C-2. Equivalent Circuit for Analysis

R_y may be written as:

$$R_y = \frac{(h_{ib1} + R_x)(R_2 + R_{in})(R_L + R_x)}{h_{fe3} R_2 R_L} \quad (\text{III-C-4})$$

The circuit may then be redrawn as in figure III-C-3, and we find:

$$\frac{e_{out}}{e_2} = \frac{R_y}{R_y + R_1} \frac{\frac{R_x R_L}{R_x + R_L}}{h_{ib2} + \frac{R_x R_L}{R_x + R_L}} \quad (\text{III-C-5})$$

$$\frac{e_{out}}{e_2} = \frac{R_y}{R_y + R_1} \frac{1}{1 + \frac{h_{ib2}(R_x + R_L)}{R_x R_L}} \quad (\text{III-C-6})$$

In general, this reduces to

$$\frac{e_{out}}{e_2} = \frac{R_y}{R_y + R_1} \quad (\text{III-C-7})$$

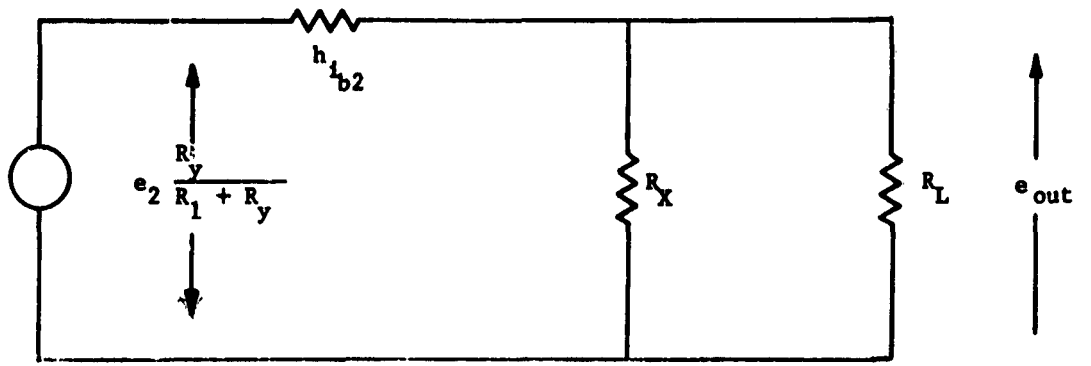

Figure III-C-3. Simplification of Figure III-C-2

APPENDIX III-D

ANALYSIS OF FIVE TRANSISTOR ACTIVE FILTER NETWORK

ANAL: This Appendix presents an analysis of the circuit shown in figure III-17.

The assumptions on which this analysis is based are:

1. Currents through R_2 and R_3 remain constant.
2. Any AC voltage appearing at the base of Q_1 appears unattenuated in the output.
3. AC base current to Q_1 is negligible compared to the AC collector current of Q_2 and Q_3 .

The base current for Q_5 is calculated as:

$$i_{b5} = \frac{e_{out}}{R_7 + \frac{R_{in5} R_8}{R_{in5} + R_8}} \cdot \frac{R_8}{R_{in5} + R_8} = \frac{e_{out} R_8}{R_7 (R_{in5} + R_8) + R_{in5} R_8} \quad (\text{III-D-1})$$

$$i_{c4} = h_{fe4} L_{b5} = \frac{e_{out} R_8 h_{fe4}}{R_7 (R_{in5} + R_8) + R_{in5} R_8} \quad (\text{III-D-2})$$

Base current of Q_3 is

$$i_{b3} = i_{c4} \frac{R_4}{R_y + R_{in3}} = \frac{e_{out} R_8 h_{fe4} R_4}{[R_{in5} (R_7 + R_8) + R_7 R_8] (R_4 + R_{in3})} \quad (\text{III-D-3})$$

$$i_{c2} = h_{fe2} h_{fe3} i_{b3} = \frac{e_{out} R_8 h_{fe4} h_{fe3} h_{fe2} R_4}{(R_4 + R_{in3}) [R_{in5} (R_7 + R_8) + R_7 R_8]} \quad (\text{III-D-4})$$

$$R_y = \frac{e_{out}}{i_{c2}} = \frac{(R_4 + R_{in3}) [R_{in5} (R_7 + R_8) + R_7 R_8]}{R_4 R_8 h_{fe2} h_{fe3} h_{fe4}} \quad (\text{III-D-5})$$

$$\frac{e_{out}}{e_{in}} = \frac{R_1}{R_1 + R_y} \quad (\text{III-D-6})$$

APPENDIX IV

NEGATIVE IMPEDANCE CONVERTERS

A. DISCUSSION

For purposes of filter design, the negative impedance converter (NIC) may be regarded as a linear four terminal network element for which the equations may be written in matrix form as:

$$\begin{bmatrix} E_1 \\ E_2 \end{bmatrix} = \begin{bmatrix} 1 & 0 \\ 0 & -1 \end{bmatrix} \begin{bmatrix} I_1 \\ I_2 \end{bmatrix} \quad (\text{IV-1})$$

Expressed in words, it is an active device which, when terminated at its output terminals in an impedance Z , appears at its input terminals as an impedance $-Z$. (IV-1)

For the filter designer, this becomes a useful tool, and provides the ability to synthesize certain RLC network transfer functions using only two kinds of passive elements and the active element NIC.

This technique has the further advantage, compared to amplifier R-C networks, of having the active elements isolated for simplicity of design. The R-C networks are obtained by the usual methods of passive network synthesis. (IV-2)

B. PROPERTIES OF AN NIC

Let us consider a linear two-terminal pair network, figure IV-1. Here, Z_L represents an arbitrary passive impedance. The magnitude of I_2/E_2 must equal $1/Z_L$ since the terminating impedance is present. The driving-point admittance must be dependent on the character of the load impedance and the network parameters. Where the network is such that $(E_1/I_1) = (E_2/I_2)$, the device is an ideal NIC.

(IV-1) Linvill, J. G., "Transistor Negative Impedance Converters" Proc. I.R.E. Vol 41, June, 1953, pp. 725-729

(IV-2) Shea, R. F., Editor, "Transistor Circuit Engineering", Wiley 1957, pp. 417-420

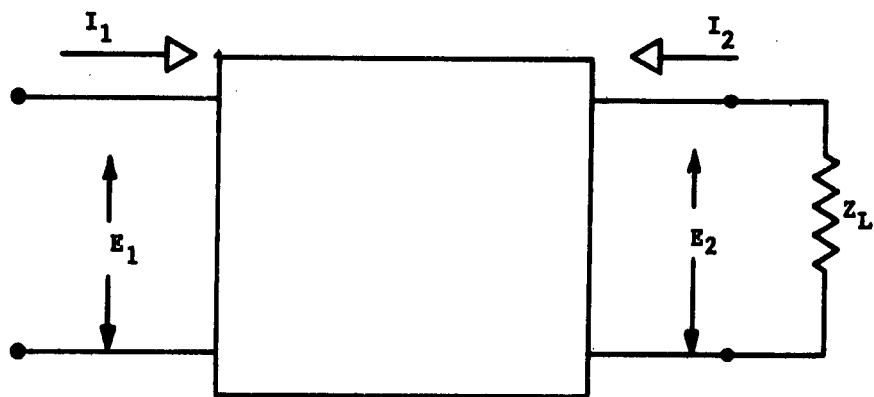

Figure IV-1. A Linear Two-Terminal Pair Network

We may define the relationships for the NIC on the basis of the hybrid parameters; (IV-3), figure IV-2.

The defining equations are:

$$I_1 = g_{11} E_1 + g_{12} I_2 \quad (\text{IV-2})$$

$$E_2 = g_{21} E_1 + g_{22} I_2$$

In this set of equations, g_{12} and g_{21} are dimensionless current and voltage ratios respectively, while g_{11} has the dimensions of admittance, and g_{22} has those of an impedance.

The input admittance has the form,

$$Y_{in} = \frac{I_1}{E_1} = g_{11} - \frac{g_{12} g_{21}}{g_{22} + Z_L} \quad (\text{IV-3})$$

If this device is an ideal NIC, then, $Z_{in} = \frac{1}{Y_{in}}$, $= -Z_L$.

This may be true if $g_{11} = 0$, $g_{22} = 0$, $g_{12}g_{21} = 1$, and these, then, are necessary conditions that a two terminal pair network be an ideal NIC.

C. DEPARTURE FROM THE IDEAL AND COMPENSATION

Unfortunately, in a practical NIC, g_{11} and g_{22} are rarely zero. One problem encountered is the difficulty in making the practical NIC circuit match the desired characteristics of the ideal model. Work along this line has been reported by Larky. (IV-4) A compensation for the parasitic parameters of the practical NIC is shown to consist of the addition of two impedances to the network, with the impedance values dependent on the desired circuit parameters. See figure IV-3. The compensating impedances are defined as $Z_a = a(g_{11})$ and $Z_b = b g_{22}$. These impedances must be adjusted to satisfy the conditions:

$$a b = 1 \quad (\text{IV-4})$$

(IV-3) Larkey, A. J., "Negative Impedance Converters" I.R.E. Trans. on Circuit Theory, Vol. CI4, No. 3, September 1957, pp. 124-131

(IV-4) Ibid.

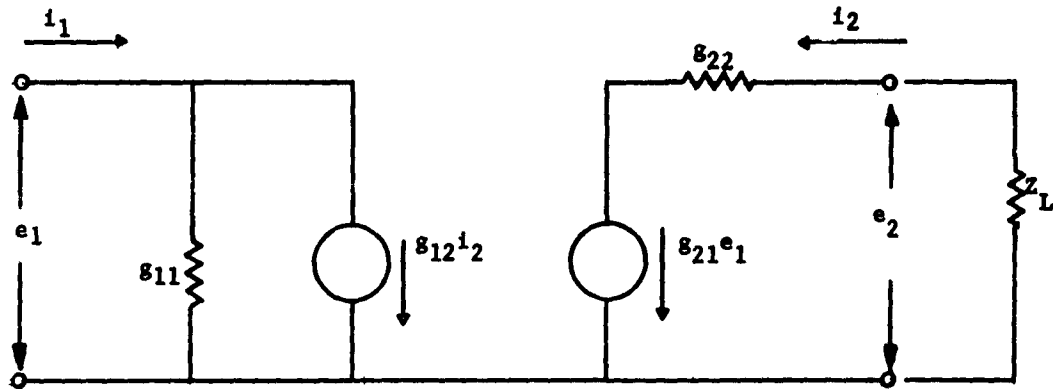

Figure IV-2. Hybrid Equivalent Circuit for NIC

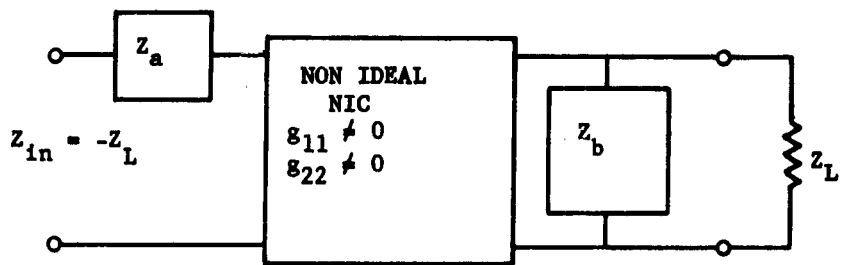

Figure IV-3. Compensation of A Nonideal NIC (After Larky)

and

$$a = 1/2 + g_{11} g_{22} + 1/4 \quad (\text{IV-5})$$

and

$$g_{12} g_{21} = a + g_{11} g_{22}. \quad (\text{IV-6})$$

Effects of drift in the parameters are considered, and sensitivity criteria established upon which circuits may be compared.

D. USE OF THE DARLINGTON COMPOUND PAIR

The Darlington compound-pair, figure IV-4, is shown to be an advantageous connection for use in the NIC, since it provides a compound alpha closer to unity than that of either of its member transistors, combined with a variation in compound alpha much less than the variation of the member transistors.

$$\alpha_c = \alpha_{q_1} + \alpha_{q_2} - \alpha_{q_1} \alpha_{q_2} \quad (\text{IV-7})$$

For use at frequencies beyond the audio spectrum, the collector capacity of the transistors used becomes important. Again, the Darlington compound-pair may provide an advantage, in that the collector capacity of the combination may be approximately that of the smaller transistor alone.

E. CHARACTERISTICS OF THE VOLTAGE INVERSION NIC

Principle characteristics of the voltage-inversion NIC (See figure IV-5) described by Linvill^(IV-5) are:

1. In the unbalanced form, the useful frequency range is greatly limited by collector capacity, although this can be corrected.
2. Use of the compound-pair transistor is necessary to reduce drifts due to alpha variation.
3. The emitter-to-base path of one transistor (Q_1 in figure IV-5) is the principle source of harmonic distortion.

F. CURRENT INVERSION NIC

A second form of NIC featuring feedback stabilized current gain, figure IV-6, serves to overcome some of these limitations. The harmonic

(IV-5) Linvill, J. G., "Transistor Negative Impedance Converters" Proc. I.R.E., Vol. 41, June 1953, pp 725-729.

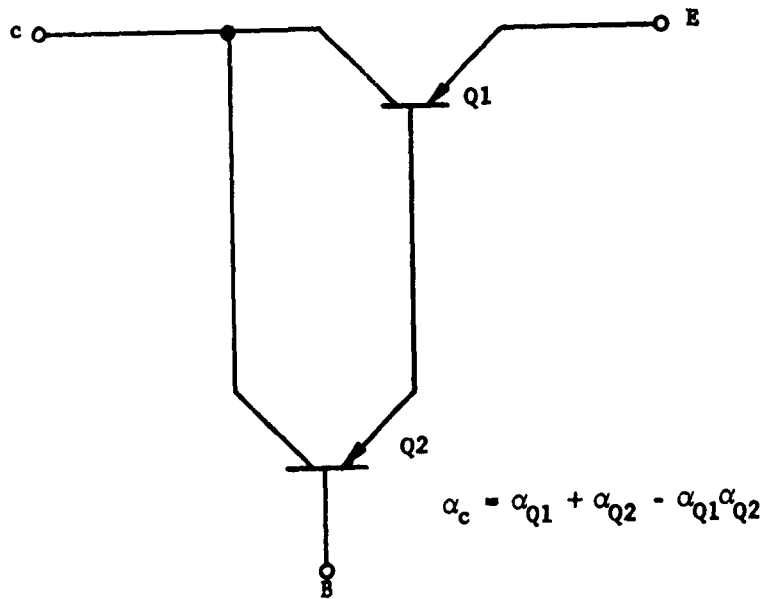

Figure IV-4. Darlington Compound-Pair

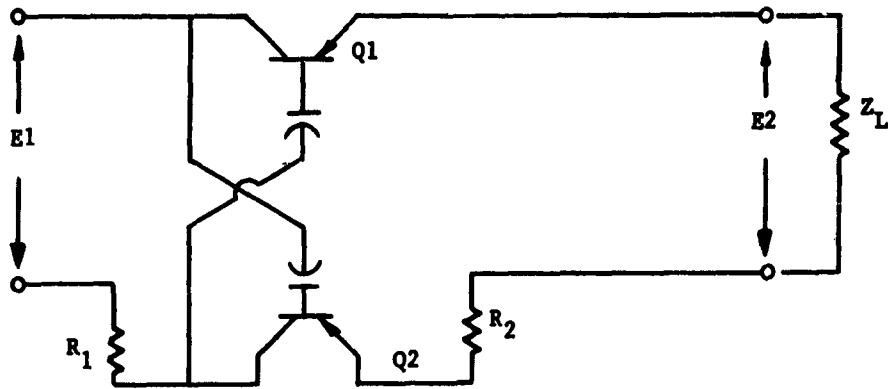

Figure IV-5. Voltage Inversion NIC, Biasing Omitted

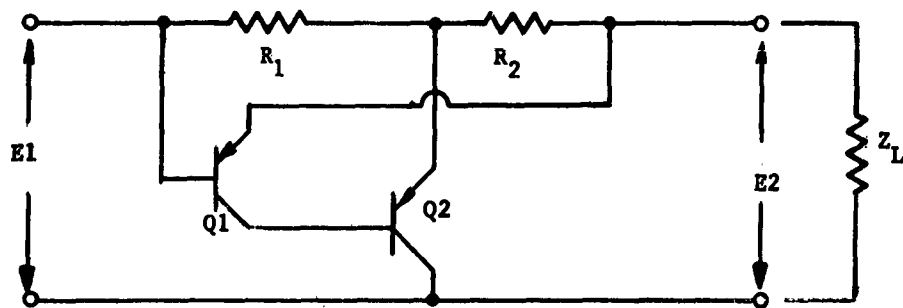

Figure IV-6. Voltage Inversion NIC, Biasing Omitted

distortion due to nonlinear base-emitter impedance is smaller since the signal current in this path is smaller compared to that of the voltage inversion NIC.

Principal characteristics of this circuit are:

1. Phase shift produced by the collector capacity is less than in the voltage inversion circuit.
2. Only one transistor (Q_2) need be compounded to reduce effects of alpha variation in both transistors.
3. Harmonic distortion is small since signal current in the nonlinear emitter-to-base path is small compared to load current.

Laboratory investigations of both voltage-inversion and current-inversion NIC circuits show substantial agreement between the analytical and laboratory results presented. Differences are attributed to the approximations necessary in the analysis.

G. INPUT IMPEDANCE OF THE NIC

From figure IV-7, we can see that the input impedance will be the negative of the load impedance. If a current of i_e flows through R_2 , then αi_e will flow in each collector circuit. A small current, $(1 - \alpha) i_e$ will flow in at the base of Q_2 , and the current entering from the source must be $-\alpha i_e$ flowing through the transistors plus $(1 - \alpha) i_e$ flowing through the capacitor. The voltage which produces the current $(1 - 2\alpha) i_e$ will be equal to $i_e R_2 + 2V_{be}$. If this latter term is small, then the impedance seen at the input terminals will be $R_{in} = R_2 / (1 - 2\alpha)$. Then, if α is close to unity, $R_{in} = -R_2$. An alternative approach, leading to the same result with a great deal more detail, is shown in a paper by Bonner, Garrison, and Kopp. (IV-6)

H. STABILITY WITH LOAD

Here it is pointed out that the circuit is open-circuit stable. This conclusion may be arrived at from another viewpoint.

(IV-6) Bonner, Garrison, and Kopp, "The E-6 Negative Impedance Repeater" Bell System Technical Journal, November 1960, pp 1445-1504.

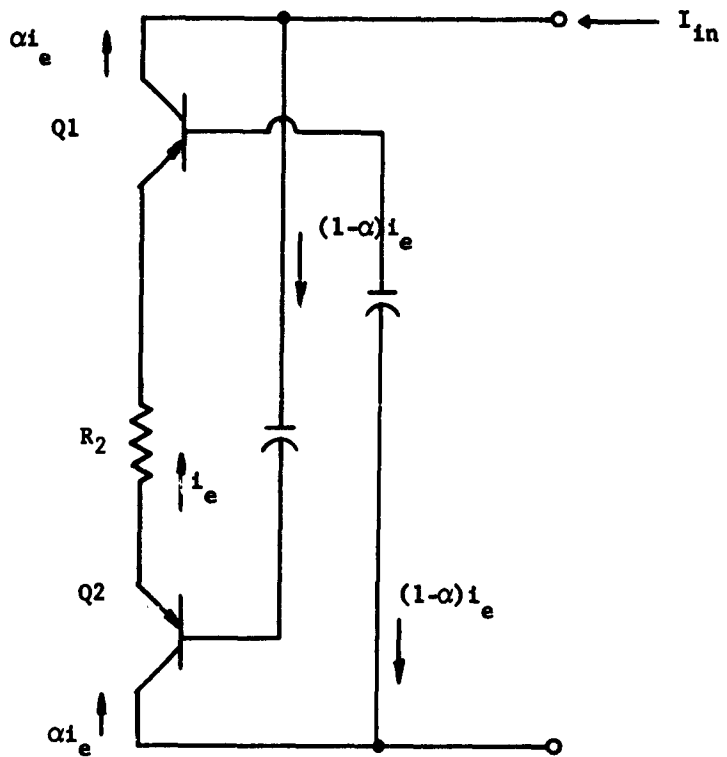

Figure IV-7. AC Path of Voltage Inversion NIC to Demonstrate $Z_{in} = -R_2$

We may redraw the circuit to the form shown in figure IV-8. This has the advantage of being unbalanced with respect to ground. This may be further redrawn into the form shown in figure IV-9, where it is shown in the form of a cascade of two amplifier circuits. The gain of this amplifier will be approximately $(R_2/R_1)(R_s/R_L)$. If the connection is to be made from the collector of Q_2 to the base of Q_1 , then the total open loop gain must be less than unity for the amplifier to remain stable. This may be accomplished with certainty where R_L is infinite, and is more difficult to achieve where the load resistance, R_L , is a short circuit.

Deviations from the ideal NIC occur as α falls with increasing frequency. A common technique which will maintain the gain a little further is to connect a capacitor across R_1 , thus providing increased gain to offset the fall due to the frequency dependence of alpha.

Similarly, the current inversion NIC of Larky^(IV-7) may be redrawn as an amplifier (figure IV-10). Here we may consider that R_1 and R_2 control a negative feedback loop, while R_L controls a positive feedback loop. For $R_L = 0$, there is no positive feedback and circuit is short circuit-stable.

I. NIC USING COMPLEMENTARY TRANSISTORS

A paper by Yanagisawa^(IV-8) provides what may be a simpler design approach than that of Linvill^(IV-9) for certain network functions requiring transmission zeros at finite frequencies.

In addition, he shows a circuit (figure IV-11) for an unbalanced, current inversion NIC using complementary transistors, which might prove to be of great interest. Either AB or AB' may be used as one terminal pair, with CD or CD' as appropriate, forming the second terminal set. The use of B'D' as the common connection leads to a more common grounding situation.

-
- (IV-7) Larky, A. J., "Negative Impedance Converters" I.R.E. Trans. on Circuit Theory, Vol. CT4, No. 3, September 1957, pp 124-131.
(IV-8) Yanagisawa, T. "RC Active Networks Using Current Inversion Type Negative Impedance Converters" I.R.E. Trans. on Circuit Theory, Vol. CT4, No. 3, pp 140-144.
(IV-9) Linvill, J. G., "Transistor Negative Impedance Converters, Proc. I.R.E., Vol. 41, June 1953, pp. 725-729.

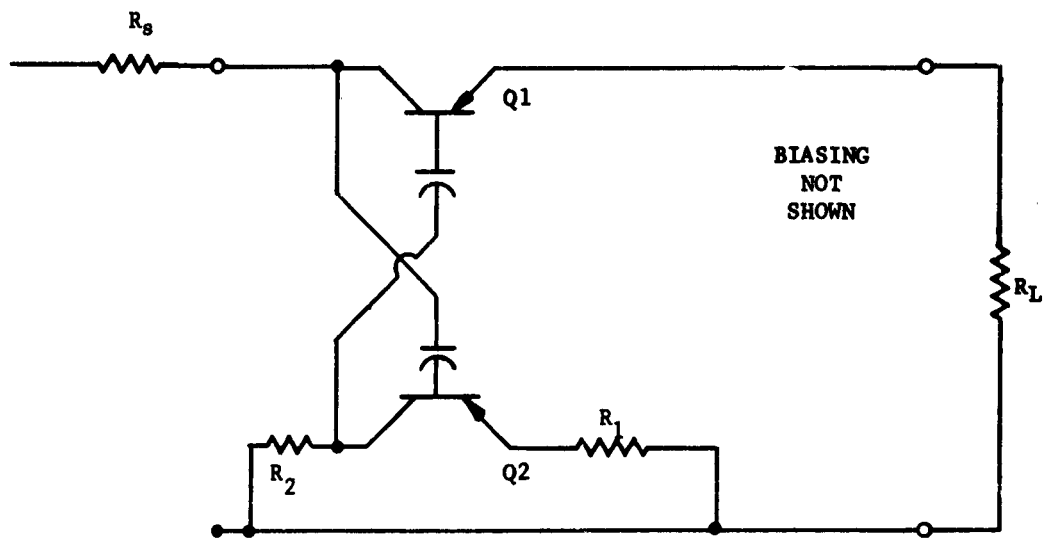

Figure IV-8. Voltage Inversion NIC Redrawn to Unbalanced Form and Showing Source Impedance

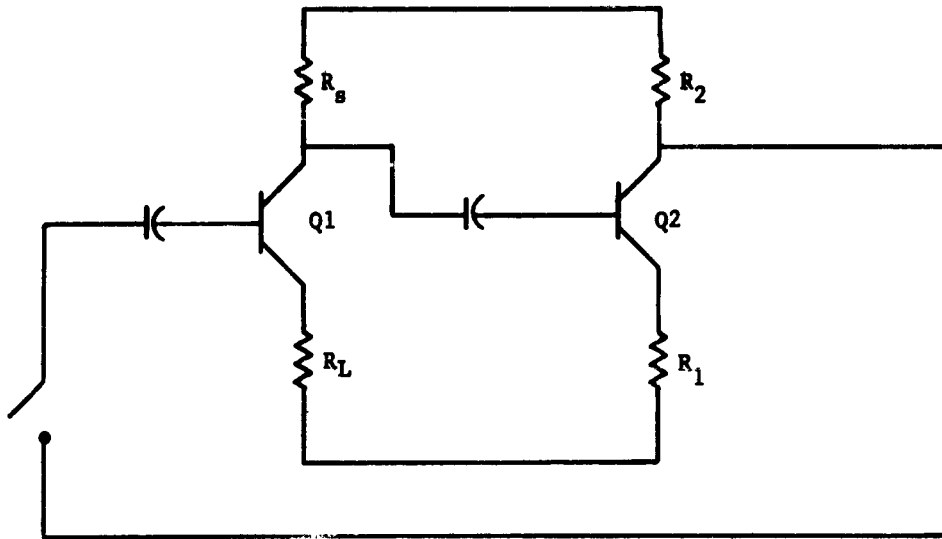

Figure IV-9. Voltage Inversion NIC Redrawn as Cascade Amplifiers to Show Stability Requirements

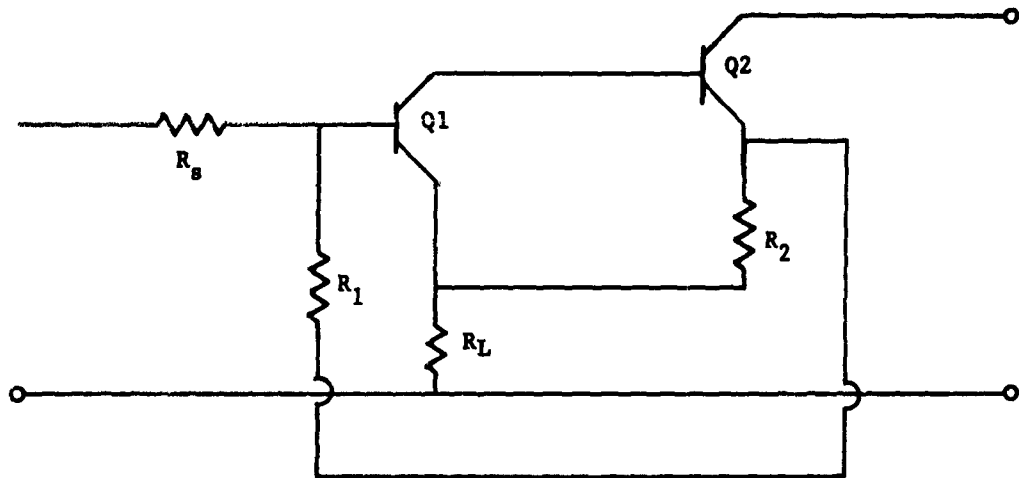

Figure IV-10. Current Inversion NIC Redrawn to Show Stability Requirement

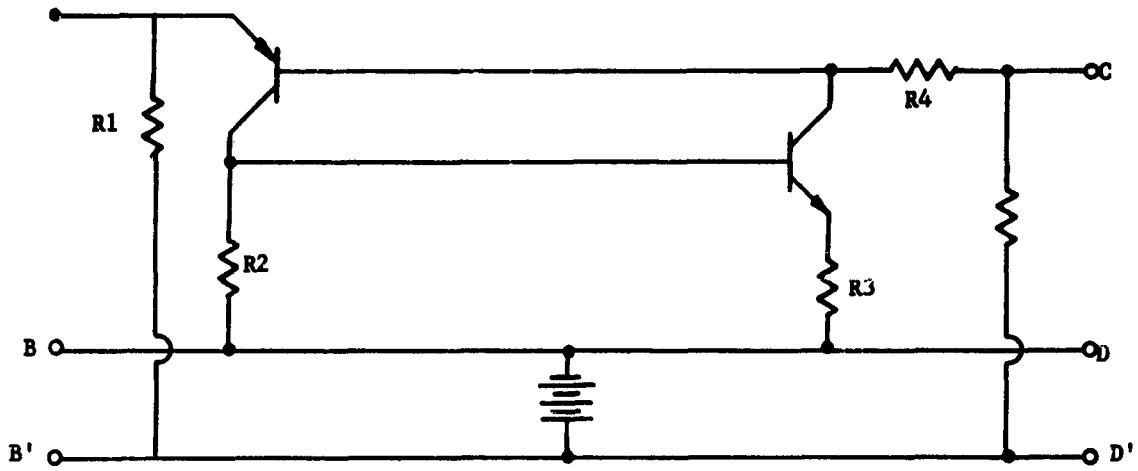

Figure IV-11. Complementary Transistor NIC of Yangisawa

For unit conversion, the resistors should have values:

$$R_1 = R_5, R_4 = r_e + (1 - \alpha)r_b, R_2 = R_3 + r_e. \quad (\text{IV-8})$$

The higher the impedance between A and B', the more negative feedback there is in the emitter of the PNP transistor, and the left-hand side of the circuit is open-circuit stable. A low impedance across CD' drains signal which otherwise would reach the base of the PNP transistor; and thus tends to stabilize the system. Thus, the system tends to be short-circuit stable on the right side. Since either set of terminals may be the input pair, the appropriate choice may be made to ensure stability.

It is informative to compare this circuit with that for a two transistor analog for a p-n-p-n switch (figure IV-12). The similarity here would appear to offer hope that this particular NIC might utilize a single p-n-p-n device.

J. EXAMPLE OF AN RC NIC FILTER

It would be informative at this point, to demonstrate the synthesis of a particular transfer function using the NIC as a circuit element. For those who have a mild interest in the subject, we recommend the example shown by Shea.^(IV-10) Further background in the techniques of network synthesis may be gained from any of several books. Among the more readable of these is "Network Synthesis" by Balabanian.^(IV-11)

To avoid the digression necessary to present a proper example of synthesis, a sample of analysis will be shown. Starting with the circuit of figure IV-13, we may write the following expressions:

$$V_1 = (1 + j\omega C_1 R_1) V_2 + [R_1 + R_2(1 + j\omega C_1 R_1)] I_2 \quad (\text{IV-9})$$

$$I_1 = j\omega C_1 V_2 + (1 + j\omega C_1 R_2) I_2 \quad (\text{IV-10})$$

$$V_2 = V_3 \quad (\text{IV-11})$$

(IV-10) Shea, R.F., Editor, "Transistor Circuit Engineering", Wiley, 1957.
(IV-11) Balabanian, N., "Network Synthesis" Prentice-Hall, 1958.

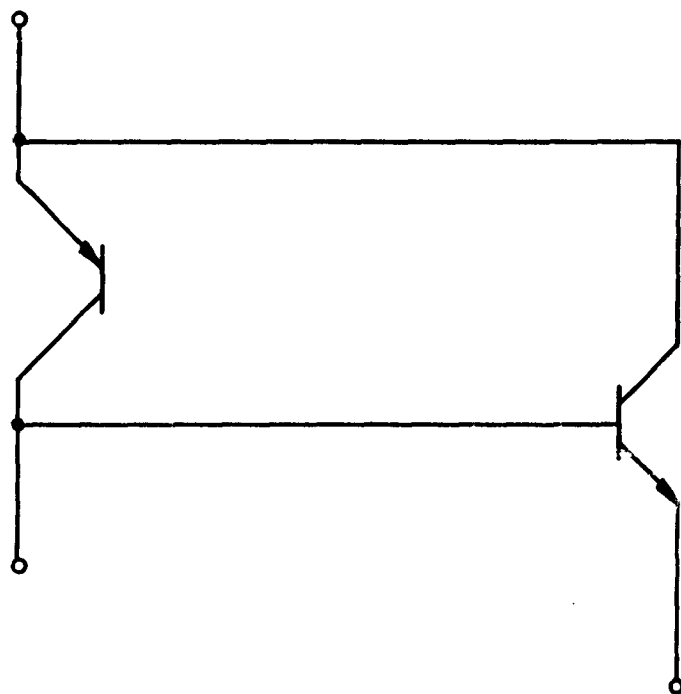

Figure IV-12. 2-Transistor Equivalent Circuit of P-N-P-N Device

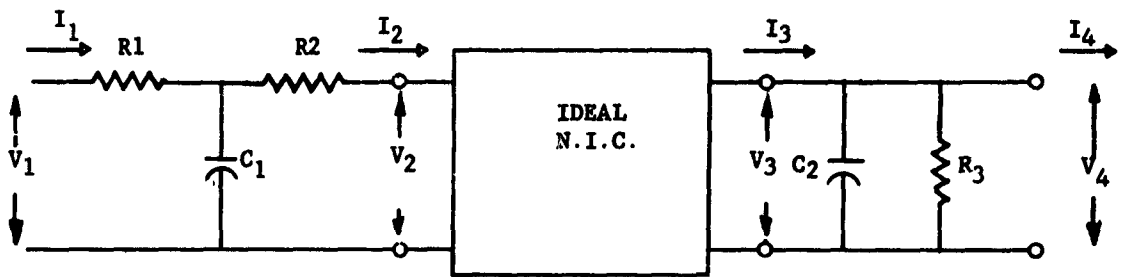

Figure IV-13. Circuit Analyzed to Show
Example of RF NIC Filter

$$I_2 = -I_3 \quad (\text{IV-12})$$

$$V_3 = V_4 \quad (\text{IV-13})$$

$$I_3 = \frac{1 + j\omega C_2 R_3}{R_3} V_4 + I_4; I_4 = 0 \quad (\text{IV-14})$$

$$\frac{V_1}{V_4} = (1 + j\omega C_1 R_1) - [R_1 + R_2(1 + j\omega C_1 R_1)] \left[\frac{1 + j\omega C_2 R_3}{R_3} \right] \quad (\text{IV-15})$$

At zero frequency, we find:

$$\frac{V_1}{V_4} (0) = 1 - \frac{R_1 + R_2}{R_3} \quad (\text{IV-16})$$

In order to make the transmission unity at DC, we have three options:

1. $R_1 + R_2$ may be made equal to zero,
2. R_3 may be made infinite
3. $(R_1 + R_2) / R_3$ may be made equal to 2.

The last situation is the only practicable alternative. If we further decide that R_1 is to equal R_2 , then we may add $R_1 = R_3$ as a condition.

In any case, V_1/V_4 may be rearranged to the form:

$$\frac{V_1}{V_4} = - \left\{ 1 + j\omega \left[2 C_2 R_3 + C_1 R_1 \left(\frac{R_2}{R_3} - 1 \right) \right] - \omega^2 C_1 C_2 R_1 R_2 \right\} \quad (\text{IV-17})$$

If this response is compared to the output across the capacitor of a series RLC circuit, having the values shown in figure IV-14, we find that an identity may be created by forcing:

$$C_1 C_2 R_1 R_2 = 1 \quad (\text{IV-18})$$

$$2C_2 R_3 + C_1 R_1 \left(\frac{R_2}{R_3} - 1 \right) = \sqrt{2} \quad (\text{IV-19})$$

Thus, the RLC circuit and the RC NIC circuit of figure IV-15 may be identical. The filter with the NIC may be regarded as two RC networks to provide the desired poles, and a feedback circuit to sharpen the response in the vicinity of the crossover frequency.

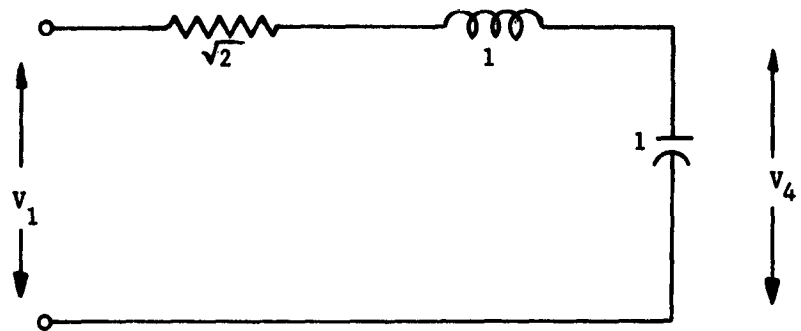

Figure IV-14. RLC Circuit Whose Transfer Function is to be Duplicated

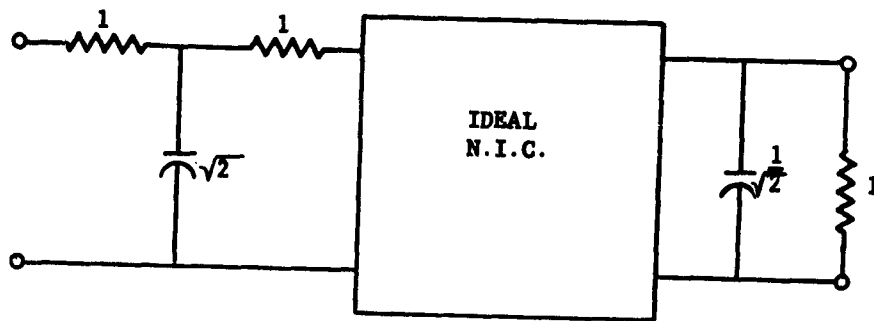

Figure IV-15. RC-NIC Filter Matching Circuit of Figure IV-14

The price for avoiding the use of the inductance is one resistor, one capacitor, and the components for one NIC.

K. OTHER CIRCUIT CONSIDERATIONS

Some of these circuits may be adapted for the transmission of DC. The voltage inversion NIC of Linvill^(IV-12) will probably require the use of several elements to provide proper potentials on the transistors. The effect of all biasing networks has been neglected in the analyses performed here. A similar problem exists for the two current inversion NIC's considered. There is also a question of the DC drop, or insertion loss which will exist. The example showed that input and output levels of an RC-NIC filter could be adjusted to unity. The requirements of the DC supply to drive the NIC have not been evaluated.

In using this system with AC inputs and output, it is definitely necessary to provide a DC supply to power the transistors in the NIC. This might be accomplished with a static converter. It is probable that the necessary DC level must be greater than the peak AC levels to be transmitted. Blocking capacitors must keep this DC from the load circuit.

L. SUMMARY

The negative impedance converter has been introduced as a circuit element. The necessary conditions for an ideal NIC have been shown. One means of compensating a practical NIC has been indicated.

Stability requirements have been pointed out for both current inversion and voltage inversion NIC units. An example was given of the use of an NIC to form an RC-NIC filter. Problem areas in reduction to practice have been indicated.

(IV-12) Linvill, J. G., "Transistor for Negative Impedance Converters", Proc. I.R.E. Vol. 45, June 1953, pp 725-729.

<p>Aeronautical Systems Division, Dir/ Avionics, Electromagnetic Warfare and Communications Lab, Wright-Patterson AFB, Ohio. Rpt Nr. ASD-TDR-63-369, INVESTIGATION OF TECHNIQUES FOR CONTROL OF INTERFERENCE GENERATED BY SWITCHING DEVICES. Final rpt, May 62, 46 p. incl. illus.; [97] p. appendices incl. illus.; 16 refs. Unclassified Report</p> <p>Report presents details and results of an investigation of basic characteristics of electronic circuitry, components, and design practices</p>	<p>1. Interference 2. Switching Circuits 3. Transients 4. Electronic Circuits 5. Suppression Devices I. AFSC Project 4357, Task No. 435712 II. Contract AF33 (657)-7268 III. American Electronic Laboratories, Inc., Colmar, Penna.</p>	<p>Aeronautical Systems Division, Dir/ Avionics, Electromagnetic Warfare and Communications Lab, Wright-Patterson AFB, Ohio. Rpt Nr. ASD-TDR-63-369, INVESTIGATION OF TECHNIQUES FOR CONTROL OF INTERFERENCE GENERATED BY SWITCHING DEVICES. Final rpt, May 62, 46 p. incl. illus.; [97] p. appendices incl. illus.; 16 refs. Unclassified Report</p> <p>Report presents details and results of an investigation of basic characteristics of electronic circuitry, components, and design practices</p>	<p>1. Interference 2. Switching Circuits 3. Transients 4. Electronic Circuits 5. Suppression Devices I. AFSC Project 4357, Task No. 435712 II. Contract AF33 (657)-7268 III. American Electronic Laboratories, Inc., Colmar, Penna.</p>
<p>Aeronautical Systems Division, Dir/ Avionics, Electromagnetic Warfare and Communications Lab, Wright-Patterson AFB, Ohio. Rpt Nr. ASD-TDR-63-369, INVESTIGATION OF TECHNIQUES FOR CONTROL OF INTERFERENCE GENERATED BY SWITCHING DEVICES. Final rpt, May 62, 46 p. incl. illus.; [97] p. appendices incl. illus.; 16 refs. Unclassified Report</p> <p>Report presents details and results of an investigation of basic characteristics of electronic circuitry, components, and design practices</p>	<p>1. Interference 2. Switching Circuits 3. Transients 4. Electronic Circuits 5. Suppression Devices I. AFSC Project 4357, Task No. 435712 II. Contract AF33 (657)-7268 III. American Electronic Laboratories, Inc., Colmar, Penna.</p>	<p>Aeronautical Systems Division, Dir/ Avionics, Electromagnetic Warfare and Communications Lab, Wright-Patterson AFB, Ohio. Rpt Nr. ASD-TDR-63-369, INVESTIGATION OF TECHNIQUES FOR CONTROL OF INTERFERENCE GENERATED BY SWITCHING DEVICES. Final rpt, May 62, 46 p. incl. illus.; [97] p. appendices incl. illus.; 16 refs. Unclassified Report</p> <p>Report presents details and results of an investigation of basic characteristics of electronic circuitry, components, and design practices</p>	<p>1. Interference 2. Switching Circuits 3. Transients 4. Electronic Circuits 5. Suppression Devices I. AFSC Project 4357, Task No. 435712 II. Contract AF33 (657)-7268 III. American Electronic Laboratories, Inc., Colmar, Penna.</p>

<p>related to the generation and reduction of interference resulting from switching devices. Solid state circuitry is emphasized both as an interference source and a suppression technique.</p> <p>Major coverage is given to filter techniques, including the development and the comprehensive analysis of active filter networks. Passive suppressor elements are considered. Circuit techniques for protection against DC line transients are presented.</p>	<p>IV. Katz, E., and Messner, F. AEL Rpt No. 61055-F Available from OTS</p> <p>VII. In ASTIA collection</p>	<p>related to the generation and reduction of interference resulting from switching devices. Solid state circuitry is emphasized both as an interference source and a suppression technique.</p> <p>Major coverage is given to filter techniques, including the development and the comprehensive analysis of active filter networks. Passive suppressor elements are considered. Circuit techniques for protection against DC line transients are presented.</p>	<p>IV. Katz, E., and Messner, F. AEL Rpt No. 61055-F Available from OTS</p> <p>VII. In ASTIA collection</p>
<p>related to the generation and reduction of interference resulting from switching devices. Solid state circuitry is emphasized both as an interference source and a suppression technique.</p> <p>Major coverage is given to filter techniques, including the development and the comprehensive analysis of active filter networks. Passive suppressor elements are considered. Circuit techniques for protection against DC line transients are presented.</p>	<p>IV. Katz, E., and Messner, F. AEL Rpt No. 61055-F Available from OTS</p> <p>VII. In ASTIA collection</p>	<p>related to the generation and reduction of interference resulting from switching devices. Solid state circuitry is emphasized both as an interference source and a suppression technique.</p> <p>Major coverage is given to filter techniques, including the development and the comprehensive analysis of active filter networks. Passive suppressor elements are considered. Circuit techniques for protection against DC line transients are presented.</p>	<p>IV. Katz, E., and Messner, F. AEL Rpt No. 61055-F Available from OTS</p> <p>VII. In ASTIA collection</p>