

UNCLASSIFIED

AD 407 913

DEFENSE DOCUMENTATION CENTER

FOR

SCIENTIFIC AND TECHNICAL INFORMATION

CAMERON STATION, ALEXANDRIA, VIRGINIA



UNCLASSIFIED

NOTICE: When government or other drawings, specifications or other data are used for any purpose other than in connection with a definitely related government procurement operation, the U. S. Government thereby incurs no responsibility, nor any obligation whatsoever; and the fact that the Government may have formulated, furnished, or in any way supplied the said drawings, specifications, or other data is not to be regarded by implication or otherwise as in any manner licensing the holder or any other person or corporation, or conveying any rights or permission to manufacture, use or sell any patented invention that may in any way be related thereto.

PASSIVE ELECTRONIC INTERCEPT TECHNIQUES AND DEVICES
Review of Soviet Literature

AID Work Assignment No. 45
(Report No. 1 in this series)

The publication of this report does not constitute approval by any U. S. Government organization of the inferences, findings, and conclusions contained herein. It is published solely for the exchange and stimulation of ideas.

Aerospace Information Division
Library of Congress

Foreword

This report has been prepared in response to AID Work Assignment No. 45 and is the first in a report series dealing with Soviet developments in Passive Electronic Intercept Techniques and Devices. It is based on Soviet open-source materials available at the Aerospace Information Division and the Library of Congress and covers the period from January 1958 through March 1958. Information not directly related to the assigned subject has been included because of its broad implications for study in this field. Materials are presented chronologically. They deal with the following topics:

- I. Receiving equipment
- II. Receive detection techniques
- III. Direction-finding techniques
- IV. Antennas
- V. Atmospheric propagation
- VI. Data transmission and recording

TOPIC I. RECEIVING EQUIPMENT

- 1) Gvozdover, S. D., A. I. Kostiyenko, and G. P. Lyubimov.
Experimental investigation of mutually synchronous operation of reflex klystrons in the three-centimeter range. Radio-tekhnika i elektronika, v. 3, no. 1, 1958, 105-111.

TK7800.R4, v. 3

The problem of extending the range of electronic tuning of klystron oscillators is of considerable interest from the standpoint of measuring technique. One of the possible ways of extending the range of electronic tuning is through the "in-pairs-series mutually synchronous" operation of several reflex klystrons with shifted frequency-response characteristics. This operation consists in klystrons being controlled by a common saw-tooth voltage and operated in series, while the zone of generation of one klystron is continuously being replaced (with small overlap) by the zone of generation of the other klystron. No jumps of frequency or of the generated power occur with it, and the resulting range of electronic tuning of the whole system appears to be close to the sum of ranges of electronic tuning of the separate klystrons.

The essence of mutual synchronization is that in the mutual synchronization band the zones of generation overlap: with the gradual increase of voltage on the repellers, the power of one klystron monotonically falls, while the power of the other klystron increases. The klystron having the greater power "catches" the other klystron having smaller power and "leads" its frequency. At a certain repeller voltage the powers of both klystrons become equal, and if their frequencies are also equal at that moment, no jump of frequency occurs. With the subsequent rise of the repeller voltage, the klystrons change their roles. The width of the synchronization band obviously depends on operating conditions and on the load of the klystrons.

In the mutually synchronous operation of three or more klystrons, no more than two mutually synchronizing klystrons operate at the same time. Repeller voltage of the other klystrons is removed by a special electronic switch, and these klystrons are disconnected until the next cycle. This is why such system operation is called "in-pairs-series" operation.

An experimental study of systems consisting of two, three, and five reflex klystrons operating in the three-centimeter range was made for in-pairs-series mutually synchronous operation. Results of investigation of the functional relationship between the synchronization band and the width of the range of electronic tuning of the resulting zone are given in the table.

Width of electronic tuning of the resulting zone Mc	Synchronization Band			Average power milli-watts
	With voltage on the repeller	With voltage on the resonator v	With resonator detuning Mc	
48	+ 3	+ 15	+ 3	9
56	+ 1.5	+ 10	+ 2	7.5
96	+ 0.5	+ 5	+ 1	2

It can be seen from the table that with an increase of the width of the electronic tuning range the synchronization band becomes smaller, and that the average power delivered into the load declines.

The shape of the resulting zone is determined by the impedance-frequency characteristic* of the whole system, reduced to the gap between the grids of the klystron resonator. This shape can be corrected by varying the impedance on the gaps with the help of impedance transformers, reactive pistons in klystron heads, and resonators.

- 2) Kostiyenko, A. I., and G. P. Lyubimov. Effect of load on mutually synchronous operation of two reflex klystrons. Radiotekhnika i elektronika, v. 3, no. 1, 1958, 112-115. TK7800.R4, v. 3

An experimental investigation is presented of the dependence on the impedance-frequency load characteristic of the width of the synchronization band and of the electronic tuning range of two klystrons operating mutually synchronously in the three-centimeter range.

* Or by a graph of functional relation between the modulus of the input impedance of the load on which each of the two klystrons is working, and the frequency.

Two cases are investigated: 1) the case of strong dependence of input load impedance on frequency, and 2) the case of weak dependence of input load impedance on frequency. Results of the investigation of case (1) have been presented in a previous article on this subject. Results of the investigation of case (2) are given in the table below:

Width of electric tuning of the resulting zone, Mc	Width of Synchronization Band	
	With voltage on the repeller, v	With resonator detuning, Mc
106	+1; -5	+5; -17
113	+1; -4	+15; -17
180	+1; -5	+7; -20
130	+1; -5	+8; -20
134	+0.5; -4	+6; -18
137	+2; -5	+14; -17

Conclusions: Results of the investigation demonstrated that both the width of the synchronization band and the resulting range of electronic tuning of two mutually synchronously operating klystrons depend on the impedance-frequency load characteristic, and attain a maximum when the load impedance varies only slightly with changes of frequency.

Small variations of the input impedance of the channel, obtained with the help of an impedance transformer, have been found to have a strong effect on the shape of the zone, and a weak effect on the width of the synchronization band and on the resulting range of the electronic tuning.

- 3) Fabrikov, V. A. Possibility of amplifying a weak modulating signal by a gyromagnetic medium. Radiotekhnika i elektronika, v. 3, no. 2, 1958, 190-197. TK7800.R4, v. 3

Magnetic oscillations of a gyromagnetic medium under the action of a circularly polarized transverse field are examined for the case in which a modulating variable field of arbitrary frequency is applied in the direction of constant magnetization of the material. The gyromagnetic medium is described by equations which are nonlinear relative to variable values of the field h and the intensity of magnetization m . This nonlinearity opens up the possibility, in principle, of using gyromagnetic

media for converting the frequency of electromagnetic oscillations. The efficiency of conversion is determined by the magnitude of magnetization of the material and the speed of attenuation in it of free oscillations. The noticeable interaction between oscillations at various frequencies which is observed under conditions of gyromagnetic resonance is connected with great losses of energy in the medium.

Conditions are found under which the imaginary part of the complex magnetic susceptibility of the medium in relation to a weak modulating field becomes positive, which corresponds to the amplification of the modulating signal by the medium.

The idea of an amplifier of electromagnetic oscillations at superhigh frequency which utilizes the nonlinear properties of a gyromagnetic medium was reflected in a Belgian patent of Pierre Marie (PV 660, 1953). This paper presents the mathematical grounds for the principles on which such an amplifier could be based.

1. *Equations of magnetic oscillations of a modulated gyromagnetic medium.*

First, equations of magnetic oscillations of a modulated gyromagnetic medium are derived. In case of circular polarization of transverse components of the variable field, time factors ($e^{i\omega t}$) relating to these components may be excluded from the equations of motion. The conversion of certain variables in the motion equation corresponds physically to a transition from a fixed system of coordinates to a system revolving around the direction of \vec{K} with angular velocity ω (\vec{K} being a unitary vector in the direction of constant magnetization -- the z-axis). When solving the problem in the new system of coordinates, such a transition makes it possible to consider the field of circular polarization as a constant one on the complex plane (x, iy). However, in certain cases it is simpler to carry out the solution of the problem in a system of coordinates revolving around the direction of \vec{K} synchronously with the magnetic moment M . This method, which was used in the Belgian patent, has been generalized by the author in an Appendix to the present paper by taking into consideration magnetic losses in the medium.

A final equation in the generalized form

$$\frac{d^3 m_z}{dt^3} + A \frac{d^2 m_z}{dt^2} + B \frac{dm_z}{dt} + C m_z = F, \quad (1)$$

describes oscillations of the gyromagnetic medium, which have been excited by the modulating field h_z in the presence of a circularly polarized transverse variable field.

2. *Oscillations of the gyromagnetic medium in the case of a small amplitude of the modulating field.*

By considering the variables h_z and $(m_z - m_0)$ as small, and limiting the solution to a linear approximation of the problem, products of these variables may be disregarded in the equation (1). The condition of resonance for longitudinal oscillations of the medium (Ω) is $\Omega = \alpha$, where α determines the natural frequency of longitudinal oscillations of the system. The imaginary part of the magnetic susceptibility of the medium χ relative to the longitudinal oscillations with the frequency Ω becomes positive. This indicates the possibility of amplifying by the gyromagnetic medium the power of the weak modulating signal magnetically polarized along the axis of the permanent magnetization of the medium at the expense of the energy of the circularly polarized transverse field. Maximum amplification ought to be obtained when the condition of resonance $\Omega = \alpha$ is realized, and when the resonant frequency of the material ω_0 is smaller than the frequency of the circularly polarized amplifying field ω by a magnitude determined by the relation

$$\frac{\omega - \omega_0}{\omega_0} > \left(\frac{\Omega}{\omega_0}\right)^2.$$

A maximum of the imaginary value of magnetic susceptibility $\text{Im}(\chi)$ with a given frequency

$$\frac{1}{T} < \Omega < \omega_0$$

is obtained when $(\omega - \omega_0)^2 = \frac{1}{3} \Omega^2$, and $\omega_1^2 = \frac{2}{3} \Omega^2$, $\omega_1 = \mu_0 |\gamma| h_1$,

where $|\gamma|$ is the absolute value of the gyromagnetic ratio.

It appears from the formulas that the reaction of the modulated medium to the action of the circularly polarized transverse field is proportional to h_1^2 , which means that the medium possesses detecting properties in relation to this field.

TOPIC II. RECEIVE DETECTION TECHNIQUE

- 1) Zheleznov, N. A. Principle of discretization of stochastic signals. Radiotekhnika i elektronika, v. 3, no. 1, 1958, 3-18. TK7800.R4, v. 3

The principle of discretization which establishes the possibility of presenting continuous signals with the help of a discrete combination of values displaced in time in relation to each other, has been expanded upon in the case of stochastic signals with an unlimited spectrum. A proof is presented of the theorem on the optimum expansion of signals into orthogonal components which gives the smallest RMS error. It is demonstrated that for a transmission line of signals with pulse modulation a potential accuracy exists which cannot be surpassed with any modulation method. A method is presented which assures high accuracy in selecting line characteristics.

Introduction. The author presents results of an investigation devoted to developing a signal theory on the basis of a new stochastic model. This model is characterized by the following properties: 1) Signals are considered as a nonstationary, stochastic process. 2) The signal duration T is finite. 3) The energy spectrum is continuous and differs from zero in the frequency band $0 < \omega < \infty$ (with the possible exception of the interval of the zero measure). 4) The correlation interval τ_c is limited, with $\tau_{\max} \ll \tau_c$. τ_c is defined as the time interval during which the correlation relation is entirely attenuated. This is why the random values $u(t_1)$ and $u(t_2)$ generated in moments t_1 and t_2 by the stochastic process $u(t)$ representing the signals, and which are separated by an interval $|t_2 - t_1| > \tau_c$ will be uncorrelated. An important parameter of stochastic signals consists of the number of "degrees of freedom," i.e., the number of uncorrelated elements

$$N_0 = \frac{T}{\tau_c}$$

The admission of $\tau_{\max} \ll T$ indicates that the proposed model possesses a large number of "degrees of freedom," which is typical in the case of signals in technical use.

In the signal theory based on the new stochastic model the need arises to extend V. A. Kotel'nikov's principle of discretization to the case of real signals whose spectrum is not limited. The mathematical problem is reduced to the presentation of signals in the form of a random function

$$v(t) = \sum_{k=0}^{N-1} u_k f(t - k\tau_1). \quad (1)$$

where u_k = random magnitudes connected in a definite manner with values which signals $u(t)$ assume in intervals $T_k \leq T$, and $f(t - k\tau_1)$ represents nonrandom functions which differ from each other only by a time shift for an interval, a multiple of τ_1 .

Theorems. The author enumerates requirements for the expansion of signals, and presents two types of circuits which fulfill this expansion (See Figs. a and b). He also introduces the criterion of accuracy with which a section of the series $v^*(t)$ represents a certain realization $u^*(t)$ of stochastic signals, or the so-called "effective criterion"

$$v^* = \frac{1}{T} \int_0^T \Delta^*(t) dt \quad (2)$$

where $\Delta^*(t) = [v^*(t) - u^*(t)]^2$ is the "error signal."

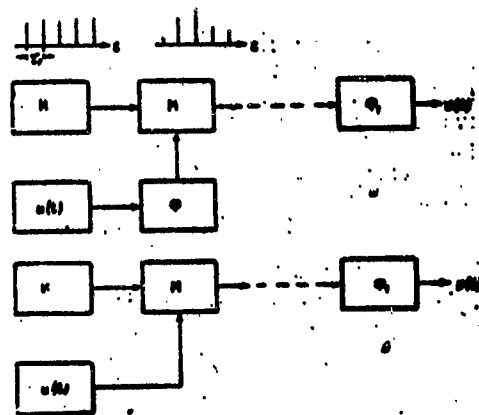

Circuits for the expansion of signals into elementary components: a - Circuit for class A; b - Circuit for class B

The author develops the following theorems: 1) on the limiting accuracy for the presentation of stochastic signals (Theorem I); 2) on the expansion of stochastic signals into orthogonal components (Theorems II, III, and IV); and 3) on some properties of series of Kotel'nikov's theorem (series K) relative to real signals with an unlimited spectrum (Theorems V, VI).

Conclusions. This investigation makes possible the formulation of the discretization principle for stochastic signals with an unlimited spectrum in a form analogous to the formulation

of Kotel'nikov's theorem. Continuous quasi-stationary signals with an unlimited spectrum can be transmitted with the help of numbers succeeding each other during a time interval τ_1 with an accuracy as close to the limiting accuracy ν_0 as is desired, if the interval τ_1 does not exceed the correlation interval, if the signal duration is much greater than the correlation interval, or if $\tau_{0\max} \ll T$.

The circuit of Class A may be considered as an elementary circuit of an idealized line with pulse modulation in which Φ is a filter at the transmitting end, and Φ_1 is a filter at the receiving end. It can be seen from part a of the Figure, that at the output of the modulator M, pulses with pulse amplitude modulation (PAM) are generated and later enter the filter Φ_1 . One can consider that in the transmitting unit (beyond the block M) a transformation of PAM into the applied type of modulation occurs, and in the receiving unit (before the filter Φ_1) a demodulation of received signals into AM pulses occurs. If these transformations are carried out without distortions, all intermediary elements (between M and Φ_1) which accomplish these operations can be excluded from the circuit.

It is obvious that the accuracy in the real line cannot exceed the accuracy attainable in an idealized line. The following conclusions may therefore be drawn:

- 1) The transmission of signals by the method of pulse modulation results principally in distortions of information, even in the absence of noise and of nonlinear distortions in the line.
- 2) In a system with pulse modulation there exists a potential accuracy of reproduction which is independent of the kind of modulation used and which cannot be surpassed. This potential accuracy is determined by the magnitude of the excess factor, and by the structure of the correlation function of transmitted signals.

The application in pulse modulated lines of the optimum filters of theorem II, which will provide either for a reduction of pulse succession frequency while retaining a definite accuracy, or for an increase of reproduction accuracy with the same succession frequency can be recommended.*

* Authors' Certificate No. 109765, with priority as of Nov. 15, 1956

- 2) Karlov, N. V. Sensitivity of a radiometer with AGC. Radiotekhnika i elektronika, v. 3, no. 1, 1958, 74-79. TK7800.R4, v. 3

Automatic gain control (AGC) in conventional radio-broadcasting receivers serves for the stabilization of the level of output power, while this level itself is conditioned by the radiosignals received. In a radiometer the output level is determined by set noise, and AGC is used to stabilize, the noise level at the receiver output, which should lead to the stabilization of the gain factor. However, it is not possible to say that AGC serves only to reduce the gain fluctuations, since there the effect of introducing fluctuations into the AGC circuit from the output of the radiometer's second detector may manifest itself to some measure. Besides, it is not clear beforehand to what extent AGC suppresses the signal in the modulation radiometer.

From the equation for the error signal one finds that the effect of the instantaneous fluctuation variations of amplification $\alpha(t)$ results primarily in a chaotic modulation of the direct component of the equation. The effective time constant in the AGC circuit with the feedback circuit closed is subject to fluctuations. Random processes describing variations of the time constant and external influence are not independent.

In order to make it possible to eliminate more completely the $\alpha(t)$ fluctuations it is necessary that these fluctuations pass quasi-stationarily through the AGC circuits.

Expressions are obtained for the sensitivity of the modulation radiometer in which the AGC was applied for the reduction of the technical sensitivity threshold. It was found that for all practical purposes this fact has little effect on the natural sensitivity threshold. The expediency of applying AGC in modulation radiometers in the presence of fluctuations of the gain factor and of the set noise factor is examined, and some measures are suggested for particular cases.

- 3) Gorbachev, A. A. Suppression of pulse noise by the nonlinear conversion of the shape of its frequency spectrum. Radiotekhnika, v. 13, no. 1, 1958, 56-61. TK5700.R32, v. 13

I. An experimental study of a method suggested by D. V. Ageyev for the suppression of pulse noise was carried out by applying two mutually opposing spectrum conversions and by amplitude limiting. In this method, the separation of signal and noise is accomplished through the joint use of two kinds of distinction between pulse noise and signal -- amplitude and spectral. Further investigation in this direction disclosed new possibilities for increasing the efficiency of similar systems.

The operation of a conversion system (represented by the block diagram) applied to the "Baltika" and "Oktava" radio-broadcasting receivers was studied under the action of pulse noise of artificial origin in the form of separate pulses with repetition frequency up to several hundred cps, and also under the action of interference of industrial origin. The use of converters with resonant characteristics was found to result in a substantial increase of efficiency of pulse noise suppression,

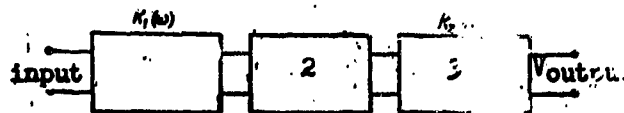

Block diagram of the converter system

- 1 - first linear spectrum converter;
- 2 - limiter with follow-up limitation threshold;
- 3 - second linear spectrum converter

which is particularly noticeable with noise levels greatly surpassing the signal level. With resonant conversion, a certain increase of the level of continuous noise background was recorded; this was most noticeable when receiving distant stations.

II. The problem consists in examining the effect of pulse noise and of the signal on the system presented in the block diagram, with various characteristics of the first converters, and in making a comparison of operating efficiency of the given system with the efficiency of a simple limiter with a limiting threshold following up the signal level. The time spacings between noise pulses are such that before the arrival of the next pulse, transients generated by the preceding pulse have enough time to practically attenuate.

III. Three types of spectrum converters were used, a linear RC converter, and two types of resonant converters.

As a result of limiting noise and using the spectrum converter, one finds that the noise spectrum shifts into the region of low frequencies, and a constant spectrum component appears. A gain in noise immunity is obtained at the expense of a lowering of the limiting threshold, and a decline of operating efficiency takes place due to the shift of the noise spectrum into the region of the passband of the second spectrum converter.

Since the limiting of noise leads to a shift of its spectrum, the possibility arises for creating linear converters which, acting together with the limiter, would provide for a shift of the noise spectrum into the necessary frequency region lying beyond the limits of the passband of the second converter.

Such results have been obtained by using resonant converters. The noise pulse at the output of these converters generates damped oscillations. As a result of their limiting, the noise spectrum shifts substantially into the region of the resonant frequency, i.e., beyond the passband of the second converter. It was found that

system operation may be essentially improved by using resonant converters. The gain in noise immunity is explained basically by the changes in the noise spectrum which have resulted from its limitation. A deficiency of resonant conversion consists in an increase of time taken by a separate pulse, sometimes up to three times as compared with the duration of the input pulse. With the RC converter a lowering of the limitation level was admissible due to the partial limitation of the useful signal with no noticeable signal distortions at the output of the second converter. In the case of resonant converters this cannot be done owing to the relatively wide passband in the second converter.

Conclusions. Results of the investigation demonstrate that the use of two mutually opposite spectrum converters jointly with a limiter makes it possible to obtain a considerably greater efficiency of pulse noise suppression than with the use of a simple limiter. The first linear converter and the limiter together form a system which can substantially convert the curve of noise energy distribution in the frequency range. The characteristic of the first converter ought to be such that 1) at the input of the limiter a maximum noise-to-signal ratio is provided, and 2) the limitation would lead to conversion of the noise spectrum form at which the second converter would accomplish signal selection with maximum efficiency.

These requirements can best be satisfied with an input converter which has a resonant form of the frequency response characteristic. Resonant frequency ought to be sufficiently high, since it should be found beyond the limits of the basic band of the useful signal spectrum.

- 4) Tartakovskiy, G. P., and Yu. M. Sergiyenko. Effect of a pulse sequence modulated by a random process on an inertial pulse detector. Radiotekhnika, v. 13, no. 1, 1958, 62-68.

TK5700.R32, v. 13

Inertial pulse detectors or equivalent circuits are often used as demodulators in radio communications with pulse-amplitude modulation. From the point of view of general communications theory, the message to be transmitted may be assigned by its statistic characteristics and, consequently, the pulse-amplitude modulation law may be considered as a random process. With the superposition of fluctuation noise on the pulse signal this process appears as one which is random in nature. This is why it is essential to analyze processes occurring in an inertial pulse detector and taking place during the action on this detector of pulse sequences modulated according to a random law.

The pulse detector is a nonlinear circuit, and this evidently complicates the problem. However, with the realization of certain limiting assumptions, one can demonstrate that the pulse detector

is equivalent to a definite linear pulse circuit. This makes it possible to find statistical characteristics of the process at the output while investigating it as a discrete random process. These characteristics delineate at the same time the law of distribution of pulse amplitudes at the detector's output, while the form of these pulses is known. By applying results available for random pulse processes, one can find statistical characteristics of the random process at the output of the pulse detector as of a continuous time function, which gives the solution of the problem.

Transfer Function of the Pulse Detector. It is demonstrated first of all, that with sufficiently broad assumptions, the "envelope" transmitting pulse detector is equivalent to a linear pulse circuit and, consequently, may be characterized by a transfer function. Formulas obtained for the transfer function make possible the determination of detector reaction to any regular pulse sequence for which certain imposed limitations are observed.

Modulation by Stationary Random Process. Let the pulse sequence at the detector's output be modulated by a stationary random process under the same conditions as in the formulation of the transfer function. The process at the detector's output may be represented as a sequence of "pulses" whose duration is equal to the period of alternation, and the form is determined by two exponential sectors. If one considers this form as identical for all pulses, then in order to find the spectral density of the process at the output, investigated as a continuous time function, it is sufficient to make use of a known formula for spectral density of a pulse sequence modulated by a random process. That spectral density is found to be equal to the product of spectral density of the discrete stationary random process at the input, the square of the modulus of the frequency characteristic of the detector, and the energy spectrum of the "pulse" of unitary amplitude, as described above.

Spectral Density of the Process at the Output. Finally, the spectral density of the process at the output of the pulse detector is determined for the simple kind of correlation function of the process at the input. The physical meaning of the result obtained is easily understood if one considers the equivalency of the pulse detector of the pulse circuit with the linear part in the form of an inertial link.

- 5) Yurov, Yu. Ya. Balanced mixer of centimetric range. Izvestiya vysshikh uchebnykh zavedeniy. Radiotekhnika, no. 1, 1958, 82-88.

A new mixer, made in the form of a rectangular resonator in which the heterodyne generates a field of the type 0,1,2, and the signal generates a field of the type 0,2,1 is discussed. The connection of the resonator with the waveguides is accomplished through narrow resonant slots cut in the middle of the walls parallel to the zero dimension. Two detectors are placed symmetrically in relation to the resonator axis, in parallel to its zero dimension, so that the electric fields of the signal have identical directions in these detectors and the heterodyne fields have opposite directions. In order to compensate for detector reactance, the detectors are fitted at the ends with sections of coaxial lines, which are placed on the resonator's cover and have movable plungers for tuning. Three tuning pins located in the corners and in the center of the resonator are used for increasing the decoupling capacity between the channels, which attains a steady value of 40 to 50 db.

The resonator dimensions are $1.12\lambda \times 1.12\lambda \times 0.22\lambda$, where λ is the resonant length of the wave. The length of coaxial lines does not exceed 0.5λ .

The most difficult problem to be solved is the matching of the mixer with the signal channel. Detailed calculations of matching conditions are presented.

In the analysis of processes occurring in the mixer, a new method is suggested for accounting for higher types of fields emerging around thin conductors and narrow slots in waveguides and resonators. Local fields around such inhomogeneities are assumed to be identical with the fields of the first approximation which emerge around thin wire and slot antennas in free space. The consistent application of this method makes it possible to compute the reflection factor and to find matching conditions of the new mixer with a rectangular waveguide.

A balanced mixer has been built according to these calculations and successfully used in a 3.2-cm band radiometer. In comparison with existing types of mixers, the new mixer displays a larger decoupling capacity, greater operating stability, and smaller overall size.

- 6) Voyutskiy, V. S. New method of measuring extremely small variable electric magnitudes. Radiotekhnika i elektronika, v. 3, no. 2, 1958, 244-248. TK7800.R4, v. 3

The two most sensitive methods known for measuring extremely low-noise electric voltages or currents with levels considerably lower than the level of set noise are the compensation and the modulation methods.

The modulation method is generally considered superior to the compensation method, which has certain deficiencies (the effect of gain variation noise, the level of set noise at the receiver output, etc.). These deficiencies are considered by some authors to be unremovable in principle. The author of the present paper, however, demonstrates that certain modifications in the compensation method would eliminate the above deficiencies entirely.

Following a description of the conventional compensation zero method, the modified method is introduced. Its schematic diagram is presented in the figure. Oscillations from the voltage sources of

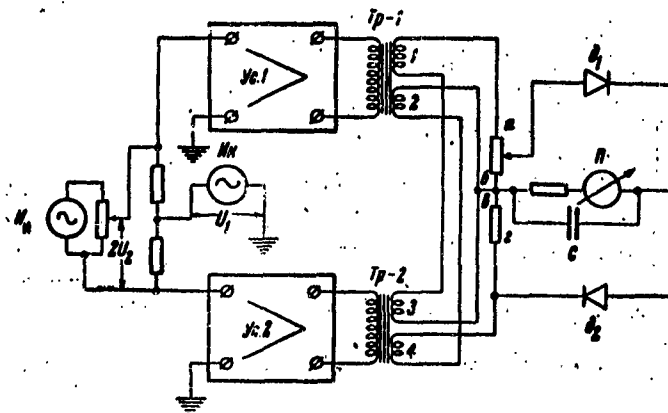

Schematic diagram of the new method

the measured and standard signals are fed simultaneously into the inputs of two identical amplifiers. The output transformers TP-1 and TP-2 of these amplifiers have two coupled secondary windings each; windings 1 and 3 are connected in such a way that they give a sum of emf's, while windings 2 and 4 give a difference of emf's. Measured signals U_R are fed into the inputs of both amplifiers in cophase; standard signals U_M are fed in antiphase. In this way, measured signals are added on the terminals a and b of transformer load resistors, and are deducted on the b and r terminals. Standard signals, on the contrary, are deducted on a and b, and added on b and r. Both summary and differential oscillations are rectified with detectors d_1 and d_2 , and integrated (averaged) with the RC filter.

The alternating voltage U_1 from the source U_N , fed in cophase into the amplifier inputs, generates a current in the circuit $a-\delta_1-\pi-\delta$, which forms one arm of the bridge. A d-c instrument (Π) is connected into the middle branch of the bridge. The voltage U_2 of standard signals, fed into the amplifier circuits in antiphase, generates a current in the other arm of the bridge, $B-\pi-\delta_2-\bar{r}$. The bridge will be balanced when $U_1 = U_2$. The process of measuring small voltages consists in the accurate establishment of the bridge balance and in measurements at the output of the standard source of the voltage corresponding to the bridge balance.

Analytical Examination of the Process. Denoting as α and β gain factors of amplifiers $Vc1$ and $Vc2$ respectively, and as U_1 and U_2 - noise voltages at amplifier inputs, and assuming that D_1 and D_2 are square-law detectors, one obtains for the rectified current in the two branches of the bridge, respectively:

$$I_1 = D_1 [(\alpha + \beta)U_1(t) + (\alpha - \beta)U_2(t) + \alpha U_1(t) + \beta U_2(t)]^2$$

$$I_2 = D_2 [(\alpha - \beta)U_1(t) + (\alpha + \beta)U_2(t) + \alpha U_1(t) - \beta U_2(t)]^2$$

The signal is considered as small relative to noise, which makes it possible to omit certain members of the equations having obtained a complete balance of the bridge when the current in the middle branch $I = I_1 - I_2 = 0$, with $D_1 = D_2$, one obtains $\overline{U_1^2} = \overline{U_2^2} - \overline{U_2 U_1}$.

The second member in the equation characterizes the fluctuations of the indicator of the output device which have remained after the averaging operation, and represents a function of mutual correlation of the amplifier set noise, with the shift $\tau = 0$. The value of this function with a sufficiently large averaging, aims at zero value. With a proper selection of equipment parameters, these fluctuations can be reduced to extremely low values. In this respect the new method is considered to be just as capable as the conventional compensation and modulation methods. The characteristics of both detectors are selected to be identical. Moreover, with the help of a variable resistor in one of the bridge arms, differences in values of D_1 and D_2 can be compensated.

Experimental Checking. Basic principles of the new method were subjected to experimental checking on a testing installation, the electric diagram of which is shown in the figure. Oscillograms obtained have demonstrated the correctness of the theoretical calculations.

Conclusions. The modulation method of measuring extremely low-noise electric voltages (or currents) with levels considerably lower than the level of set noise requires the use of technically complicated mechanical or electrical switching devices. The construction of modulators becomes complicated with the increase of modulation frequency. The measurement of low-frequency signals using the modulation method is encumbered by the presence of low-frequency noise caused by modulator operation.

Results obtained with the new method have demonstrated that with proper regulation of the equipment, the bridge balance and compensation accuracy of the measuring system do not depend on gain variation noise and on variations of the level of set noise. In this respect the new method was found to be considerably better than the conventional compensation method, and to be as good as the modulation method, while at the same time eliminating the deficiencies inherent in this method.

- 7) Knyazev, A. D. Interaction of signal and noise in an exponential detector. *Elektrosvyaz'*, v. 12, no. 3, 1958, 11-20.
TK4.E744, v. 12

In linear inertialess detectors weak signals are suppressed by strong ones. The degree of suppression is characterized by the suppression factor K_{sup} , which is equal to the ratio between the voltage of the weak signal at the detector's output in the presence of a strong signal (noise) and the voltage of the same weak signal in the absence of the strong one. The value of K_{sup} depends on the detector's degree of inertia or on the shape of the detector's characteristic. With an exponential detector (ED) the weak signal is not suppressed but increases in the presence of the strong one. This phenomenon is sometimes called "negative suppression", or for the ED -- "noise growth factor".

The paper determines conditions of detection under which as the result of interaction of two signals, the weak signal may rise in the presence of a strong one consisting of modulated or nonmodulated noise. As a consequence of such a rise, the ratio of weak-to-strong signals at the detector's output may increase in comparison with a similar ratio at the input.

General Statements. First, the effect of the shape of the detector's characteristic on the relationship between amplitudes of rectified currents of both signals is examined under the assumption that at the detector's input two modulated signals are acting whose carrier frequencies ω_s (signal) and ω_n (noise) are close but not equal to each other. It is also assumed that there is no load reaction (plate detector), and that voltages with frequencies Ω_s and Ω_n can be separated at the input by filters.

The plate current can be presented as a function of applied voltage in the form of an operating characteristic in which the current is a function of alternating voltage only, $i_a = f_{op}(e_{inp})$; assuming that the function f_{op} is continuous and has continuous derivatives, it can be presented in the form of a Maclaurin series. This series can be applied to various detector volt-ampere characteristics which are approximated by polynomials of increasing powers: quadratic, cubic, fourth degree, and higher. From these characteristics,

approximated by polynomials of higher degrees, a generalized conclusion on coefficient signs is derived: with positive signs it indicates the growth of each signal in the presence of the other, with negative signs, the suppression.

Exponential Detector (ED). In the absence of load reaction, the volt-ampere characteristic of the ED can be presented as a function of alternating voltage only, $i_a = b_0 e^{a e^{i n p}}$, where b_0 is the quiescent current in the quiescent point. When $Q = \frac{I_s}{I_n}$ is introduced as equal to the ratio of voltages of basic harmonics of the strong signal to the weak (noise/signal) at the ED's output, and $q = \frac{1}{Q}$ (the noise/signal ratio at the ED's input), one finds for the case when the level of the weak signal is constant and the strong one is changing, that with the growth of the strong signal at the ED input:

Q → 45.3 db with $a \cdot E_s = 0.25 = \text{const.}$
 Q → 33.5 db with $a \cdot E_s = 0.5 = \text{const.}$
 Q → 22.2 db with $a \cdot E_s = 1.0 = \text{const.}$

(where values of "a" are found from the tables of Bessel function moduli).

One can obtain a substantial change for the advantage of the weak signal only with values of $(a \cdot E_s)$ of the order of one or higher. By evaluating the suppression factors, which for ED are "growth factors," one finds that the weak signal growth factor at the ED output rises faster than the noise growth factor. It was found that with the growth of the strong signal (noise) at the ED input, the level of the weak signal grows sharply at the output when the product $(a \cdot E_s)$ increases. It was found that the greater the growth factor, the greater was the signal modulation percentage. With the signal interaction in the ED, the output spectra differ greatly from the output spectra of linear and square-law detectors.

Experimental Data. Examination of a series of tubes demonstrated that tubes of types 6K4II, 6B8, 6A2II (in pentode connection), 6III, 6X3, IV-50, and others possess exponential portions of their characteristics. Experimental investigation of the ED was made with a plate detector equipped with a 6A2II tube with an IF of 125 kc. Two signals -- a strong and a weak -- generated by two FCC-6 oscillators, were measured directly at the ED input, the plate circuit of which was loaded by a narrow-band RC filter tuned to the 34 cps modulation frequency of the weak signal. The presence of the filter was responsible for a considerable weakening of the beat and of the frequency of the strong signal modulation. The level of the weak signal at the detector input was maintained constant and was equal to 0.4 v. Carrier frequencies of signals differed by 1 kc, noise modulation frequency was 110 cps, and $m_s = m_n = 0.7$. Experimental relationships for the ED were obtained with $a \cdot E_s = 0.95$. A certain divergence existed between experimental and computed data, this divergence being a result of a deviation of the tube characteristic from the exponent.

Conclusions. 1. Nonlinear amplitude characteristics, peculiar to exponential detectors, contribute to an increase of the weak signal in the presence of the strong one.

2. The weak signal in the presence of the strong one increases in direct proportion to an increase in the relative level of the strong signal at the input, as does the product of the amplitude of the weak input signal and the index of the degree of the volt-ampere characteristic exponent of the tube used in ED. The presence of strong signal modulation contributes to the growth of the weak signal at the ED output.

3. When the weak signal is separated by a narrow-band filter, the relative growth of the weak signal in the ED, as compared with linear and square-law detectors, may attain 10 db and more, depending on the steepness of the exponent and the width of the exponential portion of the characteristic. A limit exists toward which the ratio of signals (strong/weak) at the ED output tends during the increase of this ratio at the ED input.

4. The number of components (harmonics and combination frequencies) which exceed the level of the fundamental harmonic of the weak signal at the ED output is larger than in the case of linear and square-law detectors, other conditions being equal.

5. Only certain of the existing types of tubes have a small exponential portion. Experimental values of the weak signal's growth factor may in practice attain 15 to 20 db with these tubes. The relative growth of the weak signal may attain 6 to 7 db.

- 8) Sidorov, V. M. Effect of weak pulse noise on receivers of FM oscillations. Radiotekhnika, v. 13, no. 3, 1958, 21-34.
TK5700.R32, v. 13

The effect of weak pulse noise* on FM receivers has not received sufficient study, nor has the theory of this problem always been based on correct assumptions. The author has therefore investigated this effect on FM receivers with any value of signal frequency at the moment of noise action. It is assumed that the FM receiver consists of an RF filter, a frequency detector, and an AF filter. The transmission factors of the RF and AF filters on center frequencies are assumed to be equal to unity.

The pulse noise at the input of the receiver is expressed as a delta function, and basic relationships for the voltage of signal and noise at the receiver input, filter output, and frequency detector output are obtained. These relationships are helpful in obtaining an expression for the spectral density of a weak pulse noise at the output of the frequency detector. In addition, these relationships are used to determine the noise at the output of receivers with ideal, idealized, and real filters.

* "Weak pulse noise" is defined as that noise which generates at the filter output a transient whose maximum amplitude is smaller than the amplitude of the useful signal.

The author compares his value for the gain Q (the ratio of maximum values of signal and noise at the output of FM receivers as compared with AM receivers in the case of ideal filters) with those obtained by other authors, explaining that their values have been based on wrong assumptions.

Conclusions. 1. The shape of noise voltage at the receiver output depends on the type of RF and AF receiver filters and on the signal frequency at the moment of noise action.

2. The relation of peak signal and noise values at the output of an FM receiver depends substantially in the general case on the type of the RF and AF filters and of their passbands. In the case of a receiver with ideal filters, this ratio does not depend on the passband of the RF filter, but is determined by the passband of the AF filter only.

3. The noise spectrum at the output of the FM receiver contains in a general case not only cosine, but also sine components. For this reason one cannot determine the maximum value of noise by way of simple arithmetical addition without accounting for the phases of these components.

- 9) Tsvetnov, V. V. Phase correlation properties of signals and of Gaussian noise in two-channel phase systems. *Radiotekhnika*, v. 13, no. 4, 1958, 53-62. TK5700.R32, v. 13

In contemporary radio navigation, phase systems are widely used, in which an unknown geometrical parameter (azimuth, range, range difference) is determined either on the basis of an interferential picture of a direct and a reflected radio wave, or by way of a measurement of the phase difference between two coherent oscillations. Systems of the first type are called radio-interferometers. Systems of the second type, in which the presence of two separate channels and a phasometric device is obligatory, may be called "two-channel phase systems". Such systems are examined in the present paper.

The paper analyzes correlation properties of the phase difference at the phase meter input. These properties play an important role in the study of noise immunity of inertial phase meters. They are also interesting from the standpoint of applied problems of phase technique. The first part of the paper examines statistical properties of noncorrelated noise, while the second part deals with phase correlation properties of strong signals and correlated noise.

Statistical Properties of Noncorrelated Noise. When noise between channels is noncorrelated, it corresponds from the mathematical point of view to the independence of four-dimensional random magnitudes, each of which is distributed according to normal law. By using known expressions for probability densities of these

random magnitudes, and after making some transformations (substitution of variables and double integration), one can obtain an expression for the six-dimensional probability density, which the author calls "the second amplitude-phase law of distribution of two-channel noncorrelated noise". When the two-channel phase system has identical channels, the distribution law becomes much simpler. The "second phase law of distribution" is expressed similarly for both nonidentical and identical channels.

Correlation Functions of the Phase Difference of a Two-Channel Noncorrelated Noise. For the case of nonidentical channels the function of phase difference depends on three correlation functions which are well defined by noise energy spectra. For the case of identical channels the expression of this function is simplified. In the analysis of normalized correlation functions of phase difference, the calculation of certain coefficients ($A_n^{(i)}$, A_n^*) presents a basic difficulty. In order to simplify this analysis, it is expedient to give approximate expressions of correlation functions for the regions of small, medium, and large correlation intervals.

From the comparison of curves for these correlation functions of phase differences, the following conclusion can be made from the point of view of energy spectra: if, in the absence of a signal in a two-channel phase system with identical channels the interferences between channels are not correlated, and if each of these interferences possesses a Gaussian energy spectrum $W_N(y)$, then the phase difference $Q_p(t)$ at the phase meter input has a larger wideband energy spectrum than the envelope, i.e., it appears to be a more "high-speed" random process. An analogous statement is true also for the other forms of noise energy spectra.

Phase Correlation Properties of Strong Signal and of Two-Channel Correlated Noise. The correlation function of the phase difference is examined for a general case and for specific cases involving identical channels with noncorrelated noise and identical channels with correlated noise.

TOPIC III. DIRECTION-FINDING TECHNIQUES

- 1) Kazarinov, Yu. M., Yu. A. Kolomenskiy, and R. I. Smirnov. Effect of fluctuation noises on the accuracy of automatic tracking with astatism of the first order and a passband controlled by the input signal. Izvestiya vysshikh uchebnykh zavedeniy. Priborostroyeniye, no. 2, 1958, 3-12.

This paper is devoted to the study of the effect of fluctuation noises on the accuracy of systems used in pulsed range meters and pulse-phase automatic frequency control. An attempt is made to evaluate the gain obtained in a system with passband control according to changes of the input signal spectrum as compared with a system with fixed parameters. This evaluation is made for the case in which the input value of the tracking system changes with a constant rate of speed in the presence of white noise at the input of the receiving system.

The system contains a receiver, time discriminator, integrator, and strobe-pulse generator. For convenience in analysis, the time discriminator or the integrator -- depending on the investigated system -- is assumed to be inertialess. Provision is made for automatic gain control of the system in order to control its passband in accordance with the input signal variations. The temporary signal position at the output of the receiver constitutes the input value of the system (t_{in}); the temporary position of the strobes is the output value (t_{out}); the voltage at the output of the time discriminator corresponding to the difference $(t_{in} - t_{out}) = \Delta t$, constitutes the error signal.

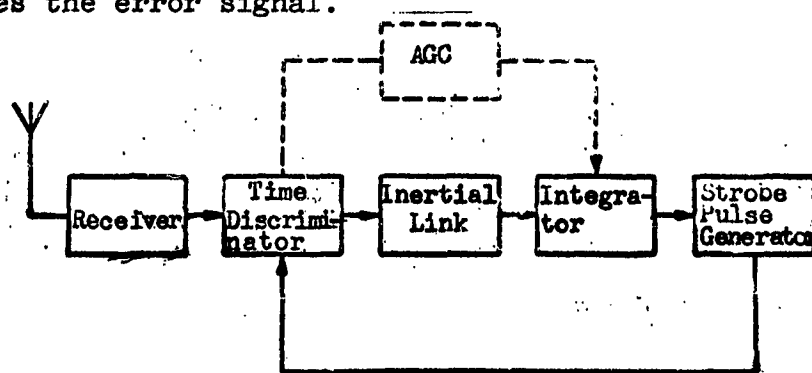

Block diagram of an automatic tracking system with astatism of the first order

1 - AGC; 2 - Receiver; 3 - Time discriminator; 4 - Inertial link; 5 - Integrator; 6 - Strobe pulse generator

Under the action of noise, the correlation relation between the neighboring values of the input magnitude is disturbed; therefore the approximation of its variations by a continuous function is not applicable. If, from the point of view of the control signal, the system may always be considered in practice as a continuous action system, then, from the point of view of noise action, such a statement is justified only with small amplification factors. As long as this condition is usually fulfilled in practice, one can consider the system as one which is closed all the time, and not only for the time of action of strobe pulses. In this case the transfer function of the closed system $\Phi(j\omega)$ may be represented by the transfer function of the open system $Y(j\omega)$. The amplification factor of the time discriminator depends on the amplitude of the signal pulse, and its amplitude characteristic can be assumed to be linear within the limits of the signal pulse. In this case the signal amplitude is considered to be constant.

The RMS tracking error $= \overline{\Delta t^2}$ is composed of the error caused by the motion of the signal pulse during the time Δt_c and of the error caused by the white noise action Δt_n . With the input signal value taken as constant, $\Delta t_c = 0$, and Δt_n^2 is found to be in direct proportion to the amplification factor of the tracking system, and in inverse proportion to the frequency of signal-pulse succession. This permits us to consider this tracking system as a filter with a comblike frequency-response characteristic, the width of the separate strips of which is determined by the value of the amplification factor. In addition, from the formula for Δt_n , one finds that a reduction of signal amplitude leads to an increase of the error.

if in the system the amplification factor (and, consequently, the passband) is controlled by the input signal, it provides for maintaining system parameters close to optimal with appropriate changes of V (where V is the rate of change of the temporary position of the signal pulse in $\mu\text{sec}/\text{sec}$). This control is provided by the introduction into the system of an AGC circuit (See fig.).

An experimental evaluation of the system was made by comparing the RMS error of the pulse-phase automatic gain control with a constant and with a controlled amplification factor.

By way of summary, the authors 1) established an expression for the RMS error depending on the basic parameters of the system; 2) established a criterion of the minimum RMS error in the presence of fluctuation noise and with a constant rate of signal-pulse speed; 3) showed that with passband control corresponding to the rate of change of signal-pulse speed it is possible to obtain a substantial decrease of the RMS error; 4) developed an optimal law of amplification factor control by the error signal voltage of the time discriminator; and 5) made an experimental evaluation which confirmed theoretical conclusions regarding the accuracy gain obtained by the introduction of the amplification factor control.

TOPIC IV. ANTENNAS

- 1) Sokolov, I. F., and D. Ye. Vakman. Optimum linear cophase arrays with a continuous current distribution. Radiotekhnika i elektronika, v. 3, no. 1, 1958, 46-55. TK7800.R4, v. 3

Introduction. C. L. Dolph's method of calculating optimum linear cophase arrays consisting of separate radiators is extended to antennas with continuous longitudinal current distribution. Dolph defines an optimum radiation pattern of an antenna of a given length as a pattern which with a given width of the major beam has a minimum level of sidelobes or, inversely, with a given level of sidelobes, has the smallest beam width.

Optimum Antennas. Linear antennas with a continuous current distribution can be considered as a limiting case of linear antennas consisting of separate radiators: the number of radiators tending toward infinity and the distances between radiators tending toward zero, with the length of the antenna remaining unchanged.

Adopting the method of computation used by Dolph for separate radiators, the authors find an expression for antennas with a continuous current distribution for r equals the level from the maximum of the major beam ($r < 1$), at which the width of the optimum radiation pattern is obtained

$$E(v) = r = \frac{ch \sqrt{\text{arch}^2 R - v^2}}{R}, \quad (1)$$

where $v = \frac{\pi D}{\lambda} \sin \theta$, D = antenna length, R = relative level of sidelobes, and θ = angle counted off from a direction perpendicular to the line of radiator distribution. From this formula it follows that in the region of sidelobes the function $E(v)$ does not decline. With high values of v , $E(v) \cong \frac{\cos v}{R}$.

Thus the level of all sidelobes of each of the radiation patterns calculated according to formula (1) is equal.

From formula (1) and from the reverse Fourier transformation used to calculate continuous current distributions corresponding to optimum radiation patterns, one finds that such optimum continuous current distribution has infinitely large values at the antenna edges. This is evidenced by the presence of delta functions in this reverse Fourier transformation. Such a distribution with infinite splashes at the edges cannot be realized exactly. However, a sharp current rise at the edges gives a definite approximation to

optimum distribution and, correspondingly, to optimum radiation patterns.

Quasi-Optimum Antennas. Of special interest is the case in which current distribution differs from the optimum by a complete absence of splashes at the edges, i.e., it appears as a distribution which declines monotonically in the direction from the center of the antenna toward its edges. In this case the normalized radiation pattern is expressed by the function

$$E(v) = \frac{ch \sqrt{\text{arch}^2 R - v^2} - \cos v}{R - 1} \quad (2)$$

and the current distribution in the antenna coincides with the optimum distribution along the whole length of the antenna, except for the edges (where delta functions are excluded).

Radiation patterns calculated on the basis of (2) are designated "quasi-optimum" patterns by the authors. It results from a graphic presentation of such patterns that the transition from optimum radiation patterns to quasi-optimum patterns is accompanied by a certain widening of the major beam of the pattern, by a growth of one of the sidelobes, and by a decline of the remaining lobes. Quasi-optimum patterns appear to be a limit of a possible deterioration of optimum patterns brought about by a reduction of current splashes at the antenna edges.

A current distribution which makes it possible to obtain quasi-optimum radiation patterns is found with a certain approximation for given levels of sidelobes at 20, 30, 40, 50, and 60 db. Such a distribution in graphic form is smooth and falls monotonically from the center of the antenna toward its edges. The reduction of the given level of the sidelobes leads to a rise in the steepness of the current slope and to a reduction of the amplitude of current distribution on the edges.

Directive Gain of Optimum and Quasi-Optimum Antennas. For a relative evaluation of the directive properties of antennas, the ratio of directive gains of the investigated antenna (G) and of an antenna with a uniform amplitude distribution (G_0) is used as $Q = \frac{G}{G_0}$ = the utilization factor of the antenna.

In the case of optimum radiation patterns with undamped sidelobes, an increase in antenna length leads to an increase of the share of energy contained in the lobes and, correspondingly, to a reduction of the Q . With the level of the sidelobes of the order of 40 db and less, changes in antenna length affect Q very little.

In the case of quasi-optimum radiation patterns, sidelobes are damped, and with an increase in the relative length of the antenna, the energy contained in the sidelobes rapidly tends to a certain limit. This is why the Q of quasi-optimum antennas can be considered as independent of the relative antenna length.

- 2) Ayzenberg, G. Z., V. D. Kuznetsov, and L. K. Olifin. Cophased wideband shortwave arrays. *Elektrosvyaz'*, v. 12, no. 1, 1958, 15-21. TK4.E744, v. 12

A cophased wideband array has been developed which is said to be free of certain deficiencies found in cophased arrays with feeding in pairs, e.g., radiation pattern distortions in the vertical plane on the edges of the operating band, which result in a reduction of antenna gain. In addition to being free from such deficiencies, the array described below also has a wider range of applications. Efforts are being made to widen its range 2 to 2.5 times as compared with arrays fed in pairs in order to overlap a range from 12.5 to 60 m with a two-antenna assembly.

Cophased antennas currently in use -- either conventional or with feeding in pairs -- require a retuning of the reflector with the change of the operating wave. This reduces the operating capacity of the radio center using such antennas. For this reason efforts are also being made to develop a new type of cophased array with a reflector which would not require retuning.

The present work deals with a four-tier antenna. Antennas with other numbers of tiers will be described separately. Two variants of cophased wideband arrays have been developed:

- 1) a cophased array with tunable reflector built as a row identical with the antenna itself. It has been designated CFD_4^4PH .
- 2) a cophased array with an aperiodic reflector built as a net of horizontal conductors. This type has been designated CFD_4^4PA .

Diagrams and Basic Data of CFD_4^4PH and CFD_4^4PA Antennas.

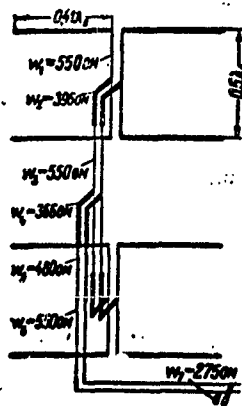

Diagram of one section of the CFD_4^4PH antenna

Fig. 1 is a diagram of one section of the CFD_4^4PH antenna. It consists of two sections connected in parallel. The construction of the section of the tunable reflector is the same as that of the array itself. The spacing between the antenna and its reflector equals $0.264\lambda_0$, where λ_0 is the optimum wavelength equaling $2d_1$, and d_1 is the spacing between neighboring antenna tiers. The cophasity of tier excitation does not depend on the wavelength. In this respect the CFD_4^4PH antenna is identical with the multiband antenna. Spacing between tiers was made equal to $0.5\lambda_0$.

In order to obtain a sufficiently high traveling-wave ratio on the feeder, quarter-wave step-

up skirts are applied which provide for a satisfactory matching of the antenna with the feeder in a wide range. In addition, the need for applying feeders for very low wave impedances is eliminated. The first two-stage quarter-wave skirt consists of two feeder sections, each $0.25\lambda_0$ long; the wave impedance of the first stage is 396 ohm, and of the second, 550 ohm. The second two-stage skirt consists of two quarter-wave sections of the feeder with wave impedances of 366 and 480 ohms.

In order to assure a possibility of antenna operation in a wide wave band, a dipole with a reduced wave impedance is used in the $CF\Pi_4^4$ antennas. Experiments demonstrated that a sufficiently good matching in the wave band may be obtained by using a dipole consisting of three conductors with a diameter \varnothing to 6 mm each located in the vertexes of a rectilinear triangle with the sides $0.0352\lambda_0$ long; a dipole of four conductors gives somewhat better results. The length of the asymmetrical dipole $2l = 0.82\lambda_0$.

Fig. 2 is a diagram of the $CF\Pi_4^4$ PA antenna. Its array does not differ from the $CF\Pi_4^4$ PH array. Its aperiodic reflector is built as a net of horizontal conductors. The spacing between neighboring conductors $d_0 = 0.0728\lambda_0$. The conductor's diameter is 6.6 mm; and the spacing between the reflector and antenna is $0.23\lambda_0$. The antenna's feeding system is presented in Fig. 2.

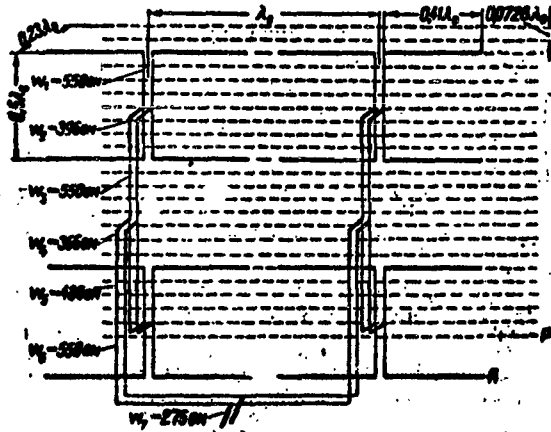

Diagram of the $CF\Pi_4^4$ PA antenna

are given. The matching of the antenna with the main feeder in the wave range was investigated experimentally by recording curves of relationship between the traveling-wave ratio on the feeder and the wave length. These curves were taken in the $(0.7 \text{ to } 2.3)\lambda_0$ band. It was found that the TW ratio does not go lower than 0.5 in the $(0.9 \text{ to } 1.7)\lambda_0$ band, or 0.3 in the $(0.7 \text{ to } 1.9)\lambda_0$ band.

Experiments also demonstrated that when controlling the directive gain, i.e., when supplying array sections with a phase shift, the TW ratio grows, as compared with the case of supplying array sections by the cophasal method.

- 3) Pokras, A. M. Choice of relative dimensions of radiator and reradiator apertures in a periscopic system. *Elektrosvyaz'*, v. 12, no. 2, 1958, 20-24. TK4.E744, v. 12

Many investigators consider a periscopic system in which the upper mirror ("reradiator") has a larger aperture than the lower mirror ("radiator") as the most efficient arrangement. The object of the present study is to show that by decreasing the reradiator aperture, and by making a proportional increase in the radiator aperture, the total gain of the system will remain constant.

Research is based on quantitative analysis of the radiator-reradiator size relationships, where the effect of "usual" (i.e., reradiator is larger than radiator) and "inverse" (radiator is larger than reradiator) relationships is compared and evaluated. Considered in this study are modern periscopic systems having paraboloidal or ellipsoidal radiator with flat or parabolic reradiators. For these four real systems, the distances between radiator and reradiator were 28 m, 43.6 m, 60 m, and 75 m, respectively. Calculations, based on other articles, were made for the wavelength of 7.5 cm and the amplitude distribution across the aperture of the radiator according to parabolic law with a 10-db drop at the edges.

A comparative study of the systems with parabolic and ellipsoidal radiators and flat reradiators indicated that the same gain can be obtained with a periscopic system by doubling the size of the radiator. Actually, the reradiator area was reduced 1.6 to 1.8 times; to compensate for this reduction the radiator area was increased 3.2 to 3.6 times. In the "inverse" relationship of radiator and reradiator dimensions, with other conditions unchanged, radiators provide a somewhat better system directivity than can be obtained with parabolic radiators. However, in agreement with theoretical studies, this advantage is reduced as the distance between radiator and reradiation is extended.

Comparative studies of results when both the radiator and reradiator were parabolic showed not only relatively small gain, but that the gain was primarily at a relatively short distance ($d = 28$ m) between the mirrors. This coincides with the theoretical forecast that we can expect a considerable gain increase only when the reradiator area is much larger than the radiator area and the distance between them is not great.

Systems with ellipsoidal-parabolic elements set up according to the "inverse" relationship demonstrate even smaller increases in gain than systems with parabolic radiators because the reradiator in the parabolic-parabolic system is larger than that in the ellipsoidal-parabolic system. As a consequence, the noncompensated mean square errors in a system with a "usual" relationship carries greater importance.

Comparative data confirm the possibility of designing periscopic systems with parabolic reradiators smaller than the radiator. Gain in these systems would be no lower than in corresponding systems with so-called conventional relations of dimensions.

Decreasing the aperture of the reradiator in all these systems will permit the use of less rigid supports because of the smaller wind pressure on the supporting structures, and will result in a wider radiation pattern. In addition, even a substantial increase of radiator area should not present any serious engineering problems, because the radiator is mounted near the ground. It has also been established that large-size ellipsoidal radiators provide greater concentration of radiation over the reradiator aperture, and can thus reduce parasitic coupling between nearby periscopic antennas with reradiators mounted on a common support. Results of the investigation confirm the expediency of using periscopic systems in which the radiator has greater dimensions than the reradiator.

- 4) Ryazanova, B. I. Choice of the most convenient dimensions and design of ferrite antennas. *Elektrosvyaz'*, v. 12, no. 2, 1958, 25-28. TK4.E744, v. 12

The effective height and inductance of ferrite antennas (loop antennas with ferrite cores) are considered in terms of coil and loop dimensions, wavelength of output signal, and "relative permeability" factors for the antenna (μ_h) and coil (μ_L). The latter factors indicate the degree to which the effective height and the inductance are greater in ferrite antennas than in loop antennas without cores.

The influence of various parameters on the effective height (h_e) and merit factor (Q_A) with constant given inductance ($L_A = \text{const}$) for a ferrite antenna is shown in tabular form. It appears from this table that the effective height is limited by the inductance, size, and cost of the ferrite antenna. The merit factor (Q_A) for a ferrite antenna, as for any coil with a ferromagnetic core, depends on resistance losses in the coil and the core. The table also shows the effect of various factors on merit (Q_A) when low-loss coils are used.

Thus, the choice of the most convenient dimensions for a ferrite antenna can be found in the table. Formulas and graphs are given in the text for the calculation of the number of loops (n) and the effective height (h_e) for a given inductance ($L_A = \text{const}$).

For great deviations from the values considered in the table, the h_e and Q_A values vary little. When the Q_A value required for the given transmission band of the input circuit is less than 100-200, then the choice of dimensions is undertaken only with a view to obtaining a greater effective height, because the needed merit factors

can be obtained easily. On long and medium waves a good performance is obtained from ferrites with relative initial permeability $m_1 = 500-1000$, and on short waves with $m_1 = 100$. Allowance is made for the possible fluctuation of inductance from the mean value range by moving the coil along the core when adjusting the receiver and by using coils with two different bands and without large mutual influence.

The coil length is generally taken as $l = (0.2-0.3) \cdot l_c$, which permits economy of wire without apparent reduction of the effective height. In broadcast receivers using cores 150 mm long and 8 mm in diameter and PE 0.1 wire, h_e of the order of 1 cm and Q_A of the order of 100 are obtained.

- 5) Burshteyn, E. L. Power received by the antenna from an incident nonplane wave. Radiotekhnika i elektronika, v. 3, no. 2, 1958, 186-189. TK7800.R⁴, v. 3

It often happens in practice that for various reasons the wave incident on the antenna aperture is not plane. This occurs, for example, when the wave source is not sufficiently removed or when the diffraction from certain obstacles near the antenna causes distortion of the plane front of the wave. A formula suitable for practical calculations of the power received in this case may be derived fairly easily with the help of the Lorentz lemma. Since, as far as Burshteyn knows, no such deducting of this relationship exists in the literature, it is therefore presented in this paper.

E_1, H_1 , represent the field generated by the antenna when it is transmitting, and E_2, H_2 , the field in space when the antenna is operating for reception, i.e., the "incident" field (accounting for distortions introduced by the receiving antenna itself). By applying the Lorentz lemma in a differential form to these two fields in a region with no currents one obtains

$$\operatorname{div}[E_1 H_2] - \operatorname{div}[E_2 H_1] = 0. \quad (1)$$

The antenna is presented schematically in the form of a regular waveguide with an arbitrary cross section S_1 and an aperture S_2 (see figure). Metallic walls Σ of the waveguide are assumed to be ideally conductive. By integrating (1) over the volume V confined by surfaces S_1 and S_2 and walls Σ , one obtains an expression linking together the fields in the waveguide cross section with fields in the antenna's aperture. Assuming that the channel in the waveguide to the left of the cross section S_1 is matched, one finds the following expression for the amplitude D of the received wave

$$D = -\frac{\rho}{2A} \int_{S_2} ([E_1 H_2]_n - [E_2 H_1]_n) dS,$$

where ρ is the wave impedance and A is the amplitude of the direct wave.

It appears from this formula that 1) the efficiency of action of the electric field E_2 is proportional to the component of the magnetic field H_1 perpendicular to it in the field of the transmitting antenna, and 2) the efficiency of action of the magnetic field H_2 is proportional to the component of the electric field E_1 perpendicular to it under transmission operating conditions.

The application of this formula for calculating the received field is complicated by two circumstances. First, (E_2, H_2) is the field in the antenna aperture during the reception, taking into account the effect of scattering in the antenna itself. The determination of this field represents an independent and very complicated diffraction problem. Second, for calculating received power one has to know both the electric and the magnetic fields E_2, H_2 in the antenna aperture S_2 , so that in the few cases when one of these fields is exactly known (for example, during the incidence of a plane wave on a plane screen with an aperture, the tangential component of the magnetic field in the aperture is known). The formula is still not sufficient.

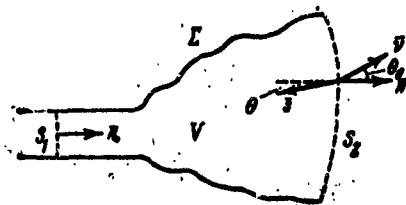

Schematic diagram of the antenna

Thus, the application of this formula is possible either for an accurate solution of a corresponding diffraction formula in the determination of the (E_2, H_2) field on S_2 , or when using any simplifying assumptions.

As an example, the author investigates the case of antennas with large apertures, and of incident waves which have a "quasi-optical" character. A solution is presented with certain approximations based on Kirchhoff's approximations.

- 6) Ayzenberg, G. Z., V. D. Kuznetsov, and L. K. Olifin. Cophased wideband shortwave array with an aperiodic reflector. *Elektrosvyaz'*, v. 12, no. 3, 1958, 21-28. TK4.E744, v. 12

The $СГД_{\frac{1}{4}}^{\frac{1}{4}}PA$ antenna array does not differ from the $СГД_{\frac{1}{4}}^{\frac{1}{4}}PH^*$ antenna array, which was described in an earlier paper by the authors (*Elektrosvyaz'*, v. 12, no. 1, 1958, 15-21). In order to secure a unidirectional radiation of the antenna, an aperiodic reflector built in the form of a network of horizontal wires is used. The

* For purposes of this summary the $СГД_{\frac{1}{4}}^{\frac{1}{4}}PA$ and $СГД_{\frac{1}{4}}^{\frac{1}{4}}PH$ antenna arrays will be referred to as PA and PH, respectively.

width of the reflector was taken somewhat wider than the width of the antenna array in order to secure a good reflecting action. Its height was somewhat greater than the distance between the upper and lower vibrators, which helps in averting a considerable energy leak beyond the upper and lower antenna edges. Experiments were made with decimetric models of both types of antennas. Feeders connecting the vibrators of the various antenna tiers were made as two-wire lines with a characteristic impedance of 550 ohm.

Conclusions. On the basis of theoretical and experimental investigation, the following conclusions were made:

1. The newly developed variant of the PH antenna was found to have good directional properties on all waves longer than $0.73\lambda_0$.
2. The PH antenna has a satisfactory matching with the power supply feeder in a wide range of waves. In the range $(0.91 \text{ to } 1.70)\lambda_0$ the traveling-wave ratio does not fall below 0.5. In the wave range $(0.71 \text{ to } 1.92)\lambda_0$, this ratio is not less than 0.3.
3. The PH antenna makes it possible to control the radiation pattern in the horizontal plane. In the shortwave portion of its operating range, $(0.8 \text{ to } 1.0)\lambda_0$, one can consider as permissible the rotation of the maximum radiation direction by $\pm(8^\circ \text{ to } 10^\circ)$. With such a rotation the level of the side lobes does not exceed $(0.4 \text{ to } 0.5)E_{\max}$. In the middle part of the operating range, $(1.1 \text{ to } 1.8)\lambda_0$, a $\pm(15^\circ \text{ to } 20^\circ)$ rotation of the maximum radiation direction is permissible. In the longwave end of the range no rotation of maximum radiation direction is advantageous since on these wavelengths the antenna has a sufficiently wide radiation pattern in the horizontal plane during the operation in the principal direction.
4. The adoption of the wave range $(0.75 \text{ to } 1.8)\lambda_0$ as the operating range of the PH antenna is considered expedient. In this entire range the antenna has good directional properties and a satisfactory traveling-wave ratio (not less than 0.4).
5. The newly developed variant of the PA antenna was found to have good directional properties on all waves longer than $0.78\lambda_0$.
6. The PA antenna has a satisfactory matching with the main feeder over a wide range. In the range $(0.89 \text{ to } 1.70)\lambda_0$ the TW ratio does not fall below 0.5. In the range $(0.82 \text{ to } 1.9)\lambda_0$ the TW ratio is not less than 0.3.
7. The PA antenna makes it possible to control the radiation pattern in the horizontal plane. In the shortwave portion of its operating range a $\pm 10^\circ$ rotation of the direction of maximum radiation can be accomplished. With such a rotation the level of side lobes does not exceed $(0.4 \text{ to } 0.5)E_{\max}$. In the middle part of the operating range a $\pm 20^\circ$ rotation of the maximum radiation direction is possible.
8. The PA antenna operates in a wide range of waves and does not require any reflector retuning.
9. It is considered advantageous to adopt the wave range $(0.86 \text{ to } 1.83)\lambda_0$ as the operating range of the PA antenna. In this entire range the antenna has good directional properties and a satisfactory TW ratio (not less than 0.4).

10. It is considered necessary to begin work immediately on the development of new variants for cophase arrays with both tunable and aperiodic reflectors. It is also necessary to develop a variant with an aperiodic reflector with two antennas suspended on either side of the reflector for simultaneous operation in two mutually opposite directions.

11. The PA antenna can be used as a wide-band receiving antenna. Under reception conditions even a considerable reduction of the TW ratio does not have any substantial meaning. In practice, therefore, one cophased PA antenna may be used in a very wide range.

- 7) Vorob'yev, Ye. A. Probability of obtaining the desired radiation pattern of UHF antennas. *Izvestiya vysshikh uchebnykh zavedeniy. Priborostroyeniye*, no. 4, 1958, 36-44.

The purpose of this paper is to investigate and provide a general solution for problems dealing with the effects of manufacturing inaccuracies on the directional pattern of UHF antennas. Inaccuracies inherent in manufacturing processes lead to phase and amplitude field errors of radiating cophased apertures.

An analysis is made of the effect of phase deviation as a function of tolerance, which is considered the main error in the determination of the field pattern at a significant distance. A theoretical development is presented and an expression of the phase error due to construction inaccuracies in relation to the theoretical phase field in a given point is established. The equation of a real field is derived, which is connected with the phase error. Thus, if the manufacturing tolerance is known, one can determine $\Delta\phi$ (ϕ - field phase) as a function of deviation with a finite probability and then determine with the same degree of probability the deviation of the real directional pattern from the calculated pattern. The relationship between possible phase deviation and tolerance is established. The real field fluctuation relative to theoretical ones can be determined through probable RMS deviation of the latter as a function of tolerance.

A numerical calculation is presented for various degrees of probability, and results are plotted. The equation of the real field vector is established. By simplifying this equation, an expression is derived for a certain allowable tolerance, which makes it possible to calculate the deviation of the real field from the theoretical one in the direction of the primary radiation as a function of tolerance for a cophased antenna with a surface utilization factor p . It is stated that the field characteristic of an antenna is fully established when the probable side [fringe] radiation is determined as a function of tolerance. This radiation can be determined from the equations discussed above by changing the sign from minus to plus in the formula for the real antenna field.

Equations are derived which make it possible to evaluate the real field pattern in principal as well as in sidelobe directions for a given tolerance, and also make it possible to evaluate the probable extent of rejects in mass production.

- 8) Vorob'yev, Ye. A. Determination of manufacturing tolerance in linear slot antennas. *Izvestiya vysshikh uchebnykh zavedeniy. Priborostroyeniye*, no. 5, 1958, 64-68.

The problem of manufacturing tolerances is particularly important in the production of high-directional antennas with considerable weakening of lateral radiation. The analysis of tolerance in multislot antennas composed of a large number of discrete radiators is especially difficult. The amplitude and phase of each radiator is relative to the general radiation field, a condition which depends not only on the accuracy in producing linear dimensions, but also on the manufacturing errors in the shape of the separate antenna elements, in the purity of their surface, and in several other factors.

Mr. Vorob'yev feels that a separation of the functions of the radio engineer from those of the constructor-technologist would be advisable in that this would result in greater efficiency in production. By expressing the radio characteristics of antennas as functions of random deviations in a real phase front in the plane of the antenna aperture, it would become possible 1) to analyze the real characteristics of antennas in general, i.e., no matter what their type is, and 2) to determine with sufficient simplicity the manufacturing tolerances according to allowable phase distortions in the antenna aperture.

The present paper is an attempt to demonstrate the optimal practical applicability of theoretical results obtained by the author in an earlier paper [Vorob'yev, Ye. A. Probability of obtaining the desired radiation pattern of UHF antennas. *Izvestiya vysshikh uchebnykh zavedeniy. Priborostroyeniye*, no. 4, 1958, 36-44].

The author discusses a method used in mechanics and machine building called "linear dimensional chains", which consists in the application of functional principles for the selection of dimensions. This method is considered from the standpoint of its application to the design and construction of antenna systems.

It is assumed that the relative tolerance for the fluctuation of the real phase front relative to the theoretical one is given (E_{rel}). E_{rel} , as the sum of errors of all antenna elements may be considered the closing link of the "dimensional chain". The finding of tolerances consists, then, in the determination of permissible errors in dimensions and in the shape of electric links of the antenna according to the given closing link of the "chain".

The selection of tolerances for all the links of the slotted antenna array depends, all other conditions being equal, not only on the assumed E_{rel} , but also on the amplitude distribution across the aperture. By making a rational selection of the measuring base, it is possible to obtain approximately the same accuracy class for the production of the entire antenna, although the relative tolerances (in parts of wavelengths) for the different antenna sections will not be equal. The measuring and technological bases must be selected in the points of maximum power radiation. This will result in an optimum structural and technological solution, while maintaining good radio-emission characteristics.

The suggested method of "electric dimensional chains" cannot be examined apart from the type, purpose, and required radiation pattern of the particular antenna system. One can speak about the optimum selection of the antenna structure and technology of production only when the electric design of the antenna has been completed.

A calculation example illustrates the suggested method of antenna design for a cophased slotted waveguide antenna system with a rectangular aperture $S = 0.1 \text{ m}^2$, and with sides of 100 and 10 cm. Values of relative and manufacturing tolerances for various points of the aperture as a function of amplitude have been presented in graphic form. The graph shows steadily increasing tolerances for slot spacing proceeding outwardly from the center of the aperture.

TOPIC V. ATMOSPHERIC PROPAGATION

- 1) Dymovich, N. D. Propagation of decimetric radiowaves in large cities. *Elektrosvyaz'*, v. 12, no. 1, 1958, 26-33. TK4.E744, v. 12

The paper deals with the results of decimetric radiowave field intensity measurements made in Leningrad in 1956. The measurements were made with a horizontally polarized 56-cm long wave, with the receiving antenna always below the roof level of buildings. The transmitting equipment consisted of a push-pull pulse generator generating 50-cps triangular radio pulses with 2- μ sec duration each. The transmitting antenna consisted of a halfwave dipole-fed paraboloid; the diameter of the mirror in the aperture was 1.5 m. The antenna gain was 25 and its effective power 7.6 kw. At the level of 0.7 in the horizontal plane the radiation pattern formed an angle of 15°, and in the vertical plane, of 13°. The transmitting antenna was 35 m above the ground. The receiver consisted of a field intensity meter in the form of a superheterodyne receiver with four IF amplifier cascades and a 500-kc passband at the 0.5 level. The receiver was placed on an automobile, which had an 8-m high telescopic mast with a half-wave dipole on top. The error of the receiving and transmitting equipment did not exceed 57%.

The distribution of field intensity of decimeter waves in the city is extremely complex and measurements alone cannot reflect true conditions. Several techniques applying statistical methods have been developed by American and English investigators. The author combines these methods and derives an empirical formula from these data for the mean values of field intensity.

Preliminary measurements of field intensity were carried out at 24 points selected at random within the city limits. Twelve readings were made at each point. One-third of all measurements were taken in dense, built-up areas, one-third in less dense areas, and one-third in relatively open spaces. These data were used to establish the law of distribution of field intensity at any given point (e.g., a 30 x 30 m lot). Results showed that in the great majority of cases the logarithmically normal distribution law of field intensity was in effect.

It is well known that in case of a logarithmically normal law of distribution the arithmetic mean of the logarithms of the measured values of field intensity is the value of greatest probability.

Thus, the value of greatest probability obtained from the results of three sets of measurements (according to building density) was considered as a representative value of field intensity at any point and plotted on a graph $E = f(r)$.

Since the transmitting antenna had highly directional orientation within the horizontal and vertical planes, the final measurements were taken 1 km apart at radially diverging points along the nine concentric paths up to the 7th km. The data were plotted on a graph as a function of distance (in km) from the transmitting antenna in logarithmic scale and field intensity (in db) relative to $1 \mu\text{v/m}$. Six graphs were plotted which reflected 6 heights of the receiving antenna (from 3.5 to 9.2 meters).

Results indicate that although the field intensity varies greatly, reaching at times 35 to 40 db, the prevailing quantity of field-intensity data is closely grouped along the mean values. Thus, on the average 80% of all field-intensity data lies within the +13 db and -7 db band off the mean value curve. On the other hand, the mean-value curve is fairly close to a straight line, making it possible to set up a comparatively simple empirical formula for defining mean values of field intensity.

The equation of radiowave propagation in free space with modifying coefficients (A) and (m) is taken as a basis for the formula, where $A = k \times 245$ is a constant of dimensions (meter)^{m-a}. When the formula is plotted on a graph of field intensity and distance in logarithmic scale, it will appear as a straight line; the tangent of the inclination angle is the coefficient (m). With appropriate selection of empirical coefficients A and m, a coincidence between the empirical straight line and curve of median values is obtained, which can be considered as a straight line at first approximation. The empirical coefficients (A) and (m) derived from the results of field-intensity measurements in Leningrad are given in a table; their average values are $A \text{ aver.} = 0.036$ and $m \text{ aver.} = 1.54$. Relative errors of field-intensity due to deviation of empirical constants from their mean values are also included.

No great difference in values for A and m coefficients for horizontally and vertically polarized radiowaves was observed.

Thus, in cases when the receiving antenna is below the roof tops, the field intensity is a function of distance and conforms with a certain law. This law is clearly indicated in the median-value curve of field intensity, and at first approximation this curve can be considered as a straight line for which the empirical formula has been derived. The values of empirical coefficients m (1.54) and A (0.036) as determined in Leningrad were compared with data obtained by other investigators (in Washington, D.C. and New York). Their m coefficient lies within the 1.22 - 1.35 range and their A coefficient between 0.02 and 0.057, which are in general agreement with the results of this study.

- 2) Trenev, N. G. Diffraction of electromagnetic ground waves on an impedance step. Radiotekhnika i elektronika, v. 3, no. 1, 1958, 27-39. TK7800.R4, v. 3

Increasingly more attention is being given to radiating and channeling systems using ground waves which propagate along impedance (or delay) surfaces. Such surfaces or their sections, in which impedance is either constant or changes according to a certain law, are characterized by the ratio

$$\frac{E \tau_1}{H \tau_2} = iZ,$$

or by a relation of tangential components, called surface impedance. Here τ_1 and τ_2 are two mutually perpendicular unit vectors in a plane which is tangent to the impedance surface.

The article investigates the diffraction of a ground wave at the edge of an impedance surface section where an impedance step exists. Related problems include the case of the incidence of a ground wave at the boundary between dry land and the sea, as well as the problem of coastal refraction.

An infinite impedance plane with Z_1 impedance at the right ($z > 0$) and Z_2 impedance at the left ($z < 0$) is examined. Waves, the fields of which are independent of the transversal coordinate, are investigated with the time multiplier $e^{-i\omega t}$ everywhere omitted. A detailed solution for the E-waves ($E_x = H_y = H_z = 0$) is presented; the solution for the H-waves ($H_x = E_y = E_z = 0$) is analogous.

A ground wave E, incident on the impedance step from the right side along the z-axis, is expressed as

$$H_x^0 = Ae^{-ih_1 z + i\sqrt{k^2 - h_1^2} \cdot y};$$

$$E_z^0 = \frac{A}{k} \sqrt{k^2 - h_1^2} e^{-ih_1 z + i\sqrt{k^2 - h_1^2} \cdot y}.$$

The propagation constant h_1 is determined by the impedance of the right half-plane Z_1 as

$$\frac{h_1}{k} = \sqrt{1 + Z_1^2}.$$

The relation of the ground-wave propagation constant h to the propagation constant in free space k is determined as the ground-wave delay, which is always > 1 . The diffraction of ground waves on the step results in a radiated field and two ground waves outgoing from the step: one to the right -- the reflected wave, and the other to the left -- the transmitted wave. These waves, as well as the field, are determined by impedances Z_1 ($z > 0$) and Z_2 ($z < 0$), and also by the magnitude of the impedance step. The modulus of the reflection factor grows with the increase of the impedance step, while the modulus of the transmission factor declines. If on the left side ($z < 0$) is an ideal metallic surface ($Z_2 = 0$), then with identical delays of

phase velocity, magnetic waves are reflected more strongly than electric. Radiation patterns have the form of a lobe, the maximum of which is oriented ahead with a certain angle of tilt toward the z-axis. The lobe's width and its angle of tilt toward the axis are determined by the relationship of impedances Z_1 and Z_2 (delays h_1/k and h_2/k). By making a proper selection of Z_1 and Z_2 (or corresponding delays) one can obtain a radiation pattern lobe of the impedance step which will have the required width and necessary tilt angle.

For the E- and H-waves all final results are identical when the delays of phase velocity on the left side h_2/k ($z < 0$) and on the right side h_1/k ($z > 0$) for the E-waves coincide respectively with the delays of phase velocity on the left and on the right sides for H-waves. When on the left side the ideal metallic surface Z_2 equals 0, then the radiation pattern of the E-waves is in the form of a lobe which is strictly oriented ahead; the radiation pattern of H-waves is in the form of a lobe whose maximum is directed ahead and forms a certain angle with the axis z ($\pi/2 < \varphi_{\max} < \pi$). The width of the lobe in both cases diminishes with the decline of the phase velocity delay, and the tilt angle toward the z-axis of the H-waves approaches $\varphi = \pi$. When for H-waves the left side impedance $Z_2 = \infty$, then the radiation pattern lobe is oriented strictly ahead. The excited field near the impedance surface decreases with the withdrawal from the step as $1/(kz)^{3/2}$. Its amplitude increases with the decline of delays of the phase velocities (h_1/k and h_2/k).

- 3) Dolukhanov, M. P. A contribution to the theory of tropospheric scatter of ultrashort waves. *Izvestiya vysshikh uchebnykh zavedeniy. Radiotekhnika*, no. 1, 1958, 49-63.

This paper is based on a short note which discussed the scattering of planar sonic waves in an inhomogeneous medium [see Pekeris, C. L. Note on the scattering of radiation in an inhomogeneous medium. *Physical review*, v. 71, 15 Feb 1947, 268-269]. On the basis of this note, the author of the present paper attempts to obtain in stricter form expressions for parameters characterizing the tropospheric scattering process.

The Problem. The capacity of the transmitter (P), the directivity factor (D) of the transmitting antenna in relation to the isotropic radiator, and the wave length (λ), are assumed to be known. Two parameters must be determined in order to solve formulas expressing the effective value of the field intensity at the point of reception of the signal. These parameters are the scattering cross section σ' and the scattering volume V.

Determination of the Scattering Cross Section. The scattering cross section is determined on the basis of the formula

$$\sigma' = 4\pi r^2 \frac{S_{\text{rec}}(m^2)}{S},$$

where S is the density of the energy flux generated by the transmitter at the scattering region; S_{rec} is the density of the energy flux at the receiving point; and r is the distance from the center of the scattering region to the point of reception. It is assumed that because of the great magnitude of that distance the incident wave may be considered as a plane wave. The derivation of the formula for the scattering cross section $\sigma(\theta_0, \Phi)^*$ is similar to the one presented by H. G. Booker and W. E. Gordon [A theory of radio scattering in the troposphere, Proc. IRE, v. 38, Apr 1950, 401-412] with the exception of certain simplifications and changes of interpretation based on recent experimental research and advances in the theory of tropospheric scatter. The final formula for the scattering cross section is given as

$$\sigma(\theta_0, \Phi) = \frac{2 \sin^2 \Phi \cdot (\overline{\Delta \epsilon} / \epsilon)^2}{a \theta_0^4}$$

In this formula it was recognized that in all cases which would be of practical interest the angle θ_0 would be so small that its sine could be replaced by its argument. As one can also see, the above formula is independent of the wave length, which fact is confirmed experimentally in the first approximation.

Determination of the Scattering Volume. In determining the boundaries of the tropospheric volume participating in the creation of scattered radiation, an examination is made of the case in which the scattering volume is limited by the natural dependence of the effective value of the scattering cross section on the angle. It occurs when the degree of directivity of the transmitting and receiving antennas is not extremely high. The total scattering volume is limited at the base by planes which are tangent to the earth's surface at points of location of the transmitter and receiver (assuming a smooth surface of the earth). All the points of the scattering volume should be distributed above these planes. The formula for the scattering volume is then used in finding the effective value of field intensity from the equation:

$$E_{eff} = \frac{2}{d_a} \sqrt{\frac{30 P \cdot D}{\pi}} \int_V \sigma(\theta_0, \Phi) dV \text{ (v/m)}.$$

In several cases it may be convenient to determine the field intensity at the point of reception according to the formula for free space, supplemented by the fading rate (F):

$$E_{eff} = \frac{\sqrt{30 P \cdot D} \cdot F}{d} \text{ (v/m)}.$$

Calculated results are compared with experimental data for the dependence of the fading rate on the distance [$F = \varphi(d)$] and for the

* The angle " Φ " in the Russian text corresponds to the angle "X" in American papers on the subject. The scale of turbulence "l" is marked in the Russian text as "a".

dependence of scattering parameters on the height above the earth

$$s = \frac{(\overline{\Delta \epsilon / \epsilon})^2}{a} = f(h).$$

Curves show a close correspondence between calculated and experimental data.

- 4) Trenev, N. G. Diffraction of electromagnetic ground waves on a semi-infinite impedance plane. Radiotekhnika i elektronika, v. 3, no. 2, 1958, 163-171. TK7800.R4, v. 3

The paper examines the problem of diffraction of E- and H-waves at the edge of a two-sided impedance half-plane. [See also: Trenev, N. G. Diffraction of electromagnetic ground waves on an impedance step. Radiotekhnika i elektronika, v. 3, no. 1, 1958, 27-39 (summarized in this report) and Senior, T. B. A. Diffraction by a semi-infinite metallic sheet. Proceedings of the Royal Society, Series A, v. 213, 22 July 1952, 436-458.] The present paper is related to the latter reference and follows the same line of mathematical treatment.

Two cases are studied: 1) a half-plane with impedances above its upper surfaces and below its lower surfaces, and 2) a half-plane with impedances above its upper surfaces and below its lower surfaces differing by their sign only. During the diffraction of ground waves at the edge of an impedance half-plane, a reflected ground wave emerges which is transmitted downward, and a radiated field is produced. The transmission of the ground wave occurs only in case of equality of impedances on both sides of the half-plane (impedance Z with $y = \pm 0; z > 0$). The modulus of the reflection coefficient is equal to the modulus of the transmission coefficient and grows monotonically, approaching the value of $1/\sqrt{2}$ with the growth of the delay. When the half-plane impedance is Z above the upper surface and $-Z$ below the lower surface of the half-plane, then only a reflected ground wave exists; the reflection modulus grows monotonically with the increase of delay, approaching unity.

The radiation pattern has the shape of a symmetrical lobe with a maximum oriented sharply forward ($\varphi = \pi$). The lobe narrows as the delay declines. In addition, normalized radiation patterns for the half-plane with equal impedances above and below, and with impedances differing only in sign, coincide.

A disturbed field near the impedance surface decreases with its withdrawal from the edge of the half-plane ($z > 0$), according to

$$\frac{1}{(kz)^{3/2}}$$

Its amplitude grows with the reduction of the delay of the phase velocity.

- 5) Braude, S. Ya., N. N. Komarov, and I. Ye. Ostrovskiy. Statistical character of centimetric radiowave scattering by rough sea. Radiotekhnika i elektronika, v. 3, no. 2, 1958, 172-179. TK7800.R4, v. 3

A signal propagating above a rough sea surface is considered as consisting of a coherently reflected direct wave, and of a sum of elementary reflected waves with random phases and amplitudes, giving a spectrum which is characteristic of the scattering surface. The statistical character of amplitudes and phases of received signals permits the use of methods of mathematical statistics for the study of phenomena connected with the propagation of microwaves. Of the two methods of accounting for effects of heterogeneity of the propagating medium, the first -- the solution of Maxwellian equations for statistically nonhomogeneous media and uneven surfaces -- presents considerable difficulties; the authors therefore used the second method, i.e., that of developing a phenomenological theory, proceeding from statistical properties of the received signal.

Probability Characteristics of the Signal and of the Scattering Surface. In order to illustrate the possibilities of such a method the problem of centimetric radiowave propagation above a rough sea is examined. For simplicity it is assumed that the propagation path is so short that the main cause of signal amplitude fluctuations is signal scattering on the rough sea surface. In these conditions the field strength at the point of reception may be considered as a result of the superposition of 1) the "direct" wave coming directly from the transmitter into the receiver, 2) the regular wave coherently "reflected" from the separating surface, and 3) a large number of elementary waves scattered by the sea. Thus the summary vector:

$$E(t) = E_0 \cos \omega_0 t + E_{\text{refl}} \cos(\omega_0 t + \varphi) + \sum E_s \cos(\omega_s t + \varphi_s) \quad (1)$$

and

$$\omega_s = \omega_0 \pm \Omega_s, \quad (2)$$

where Ω_s is the Doppler shift of frequency of scattered waves. A "roughness" coefficient of the sea surface is introduced as

$$\alpha^2 = \frac{\sum \bar{E}_s^2}{E_0^2}$$

which characterizes the value of noncoherently scattered energy.

The accuracy of such a model for describing the field $E(t)$ can be verified if from the analysis of experimental data it appears that the curves of the distribution of amplitudes R , $W(R)$, and of phases ψ , $W(\psi)$ found from tests coincide with the curves of distribution for the same magnitudes obtained from formulas (1) and (2).

The authors apply known mathematical methods to obtain expressions for the amplitudes, phases, and other parameters of all the components of the basic equations.

Using the same mathematical model, the authors also find 1) the low-frequency spectrum of the fluctuation spectrum $F(\omega)$, and 2) the velocities of nonhomogeneities which specify the scattering of incident energy. The Doppler shift of frequency of scattered waves Ω_s is caused by the regular motion of nonhomogeneities of the sea surface having a velocity v_* , and also by chaotic motions having velocities v_s at various surface elements.

Experimental Data. In order to check the accuracy of the theoretical model, tests were conducted to determine the distribution of amplitudes R obtained experimentally, and to compare them with the theoretical curve $W(R)$. The time motion of 3.2-cm signals was measured with the transmitter located at a 6-m elevation above the sea surface, and receivers at 1, 7.5, and 16 m above the surface. The length of the path was 750 m, running entirely above the sea. In order to determine the value of the direct signal altitude field cross sections, i.e., signal amplitudes as a function of the elevation of the receiving antenna, were taken. From these, determinations could be made of the signal values as interference maxima and minima patterns. The amplitude of the direct signal was determined as

$$E_0 = \frac{E_{\max} + E_{\min}}{2}.$$

From photographic data for each given receiving antenna elevation the values of signal amplitudes were determined every 2 sec; the $W(R)$ curve was drawn on the basis of obtained data. Good agreement with computed results was obtained.

Also from experimental data the regular velocity v_* and the chaotic velocity $\sqrt{v_s^2}$ of the scattering nonhomogeneities were found for an almost calm sea. For v_* a value close to zero was obtained, and for $\sqrt{v_s^2}$, a value of 1 to 2 cm/sec.

The authors conclude that a combination of the theoretical method with a corresponding experimental investigation provides for the determination of important physical parameters characterizing processes occurring during the scattering of radiowaves by a rough sea surface.

It is assumed that this method may also be used in studying several other problems of radiowave propagation in the troposphere, in particular for obtaining certain data on the nature of nonhomogeneities causing tropospheric scattering.

- 6) Bass, F. G., and V. G. Bocharov. Contribution to the theory of scattering electromagnetic waves on a randomly rough surface. Radiotekhnika i elektronika, v. 3, no. 2, 1958, 180-185. TK7800.R 4, v. 3

The paper presents a study of the scattering of electromagnetic waves on a randomly rough surface with irregularities which are small in comparison with the wavelength. The problem is solved by applying the theory of disturbances.

According to this theory, the surface deviation from a certain plane may be considered as a small correction. The field generated by a dipole placed above a randomly rough surface $z = \zeta(x, y)$ is examined. If the surface is infinitely conductive, boundary conditions for the electric field will be expressed as

$$E_x + E_z \frac{\partial \zeta}{\partial x} = 0; \quad E_y + E_z \frac{\partial \zeta}{\partial y} = 0. \quad (1)$$

The field \vec{E} on the surface is expanded in series in powers of ζ :

$$\vec{E}(x, y, \zeta) = \vec{E}(x, y, 0) + \left(\frac{\partial \vec{E}}{\partial z} \right)_{z=0} \zeta + \frac{1}{2} \left(\frac{\partial^2 \vec{E}}{\partial z^2} \right)_{z=0} \zeta^2 + \dots \quad (2)$$

The solution of the wave equation will also be sought in the form of series:

$$\vec{E} = \vec{E}^{(0)} + \vec{E}^{(1)} + \vec{E}^{(2)} + \dots \quad (3)$$

Here $\vec{E}^{(0)}$ is the dipole field above an ideally conductive surface. Making appropriate transformations and substitutions, one finds for fields in the first and second approximations the following expressions:

$$\left. \begin{aligned} E_{x,y}^1 &= - \frac{\partial E_{x,y}^{(0)}}{\partial z} \zeta - \frac{\partial \zeta}{\partial x,y} E_z^{(0)} \\ E_{x,y}^2 &= - \frac{\partial E_{x,y}^{(1)}}{\partial z} \zeta - \frac{\partial \zeta}{\partial x,y} E_z^{(1)} \end{aligned} \right\} z = 0. \quad (4)$$

$$(5)$$

From (4) and (5) one can see that a uniform problem with boundary conditions on a rough surface was reduced to a nonuniform problem with boundary conditions on a plane. Knowing the field on the surface, one can find the fields in any point of space according to Kirchhoff's formulas.

1. The field of the first approximation and dispersion tensor.

Statistical properties of a scattered electromagnetic field are characterized by an average field \bar{E}_i and by the dispersion tensor

$$G_{ik} = \overline{(E_i - \bar{E}_i)(E_k - \bar{E}_k)^*}$$

(The line denotes the averaging along the sets.)

One finds formulas for ϵ_{ik} for vertical and horizontal dipoles, and limiting cases of strong and weak correlation between points are examined.

2. *The field of the first approximation and dispersion tensor.*

In turn, one finds the second statistical characteristic $\overline{E}_i^{(2)}$ and the Umov-Poynting vector for the horizontal and vertical dipoles.

TOPIC VI. DATA TRANSMISSION AND RECORDING

- 1) Siforov, V. I. Conditions for obtaining high carrying capacity of communication channels with random parameter variations. *Elektrosvyaz*, v. 12, no. 1, 1958, 3-8.
TK4.E744, v. 12

In radio communication channels based on the principle of distant tropospheric and ionospheric propagation of ultrashort waves, as well as in ordinary short-wave radio channels used for nationwide communication service, random variations of their parameters occur. The effect of these fluctuations appears as random-amplitude and phase-time modulation of transmitted signals. Besides, in channels of this type there is multibeam propagation of radio-waves where each beam is subject to random variations in amplitude and in propagation time. All these factors tend to lower the carrying capacity of communication channels.

The present study outlines conditions under which communication channels obtain very high carrying capacities at low additive noise levels. An ideal condition is assumed whereby the useful signal is transmitted through a communication channel with random variations of parameters, and its frequency spectrum lies within the frequency band of the channel. It is assumed that the channel has a multibeam propagation of waves and each beam has random variations in amplitude and propagation time. Each input and output signal has a limited frequency spectrum:

According to Kotel'nikov's theorem, the output signal is exactly defined by the cumulative effect of a whole series of random variation values of its amplitudes and propagation time recorded at some instants. Each of these values can be found by direct or indirect measurement of the output signal. Within the limits of the chosen idealization, in which are assumed limited frequency spectra for input and output signals, as well as random variations of channel parameters, the exact values of the input signal can be computed from a system of equations, from which an exact determination of the output signal values has been made. The resulting data are used in the above-mentioned equations to form an inequality:

$$\sum_{i=1}^k [(\Delta_i F)_a + (\Delta_i F)_\tau] < \Delta f.$$

The left side of this inequality represents the total bandwidth of frequency spectra of all statistically independent random variations

of parameters in the multibeam communication channel; the right side represents the frequency band of this channel. In the final analysis results show that the idealized channel under consideration can transmit an unlimited quantity of information. In other words, the carrying capacity of the channel becomes infinitely great through reduction of additive noise. Channels with these characteristics are called "channels of the first type."

Therefore the following theorem is considered to be proved: "When the total bandwidth of the frequency spectrum of statistically independent random variations in amplitude and duration of signal propagation in all the beams of the channel with a finite number of beams is less than its frequency transmission band, then with unlimited reduction of the level of additive noise the carrying capacity of the channel increases indefinitely."

Thus, as distinguished from the ordinary case of a simple additive superposition of fluctuation noise, the presence in the spectrum of the transmitted useful signal of additional noise components caused by random parameter variations does not limit the carrying capacity of the channel. This is explained by the fact that in this case the additional noise components have a strong correlative bond. However, if the above inequality is not satisfied, the carrying capacity of the channel approaches some finite magnitude if the level of additive noise is reduced indefinitely. Such channels are called "channels of the second type." A concept of the "natural capacity" of channels of the second type is introduced, i.e., of the greatest possible carrying capacity that can be obtained by applying a sufficiently strong power of the useful signal, and by using its most suitable coding. It appears, therefore, that this inequality is a necessary and sufficient condition if the investigated channel is to be classified as a channel of the first type.

One has to note that the above conclusion on the unlimited carrying capacity of the channel is correct only with the accepted assumption on limited frequency spectra of random parameter variations of the channel, and of random variations of the useful signal. With other idealizations closer to reality which take into account the unlimitedness of frequency spectra of random parameter variations, and also other factors, the carrying capacity with an unlimited reduction of the level of additive noise for all channel types enumerated above appears to be finite. However, it appears to be much larger than the carrying capacity calculated by usual formulas for channels with permanent parameters and with equivalent additive fluctuation noise.

Conclusions. On the basis of this analysis, the following conclusions on the basic properties of channels with random variations of parameters are presented:

1. Multibeam communication channels with sufficiently slow random variations of absorption and of the duration of wave propagation in every beam, belong to the first type of channels, i.e.,

they have a very high carrying capacity with a low level of additive noise.

2. With the acceleration of channel parameter variations, and with the increase in the number of its beams, starting from a certain threshold, a sudden change of its properties, namely, a sharp reduction of its carrying capacity, occurs. In the process an actual transition from a channel of the first type into a channel of the second type takes place.

3. When the frequency band of the multibeam channel with a given constant number of beams and a given rate of variations of its random parameters is widened to a certain limit, a sudden transition of the second-type channel into a first-type channel occurs, which corresponds to a sharp increase of the carrying capacity.

In particular, it is possible to obtain a channel of the first type with a very high carrying capacity by merging two channels of the second type which have very limited carrying capacities. The bandwidth of the first type channel will then be the sum of the two bands.

2) Shastova, G. A. Noise immunity of the Hamming code. Radiotekhnika i elektronika, v. 3, no. 1, 1958, 19-26.

TK7800.R4, v. 3

A comparison is made of noise immunity in transmitting discrete messages using the Hamming code, a simple binary code, and a code with repetition and even protection. Formulas are presented which provide for an evaluation of these methods with two different initial conditions: 1) a constant probability of binary symbol distortion, or 2) a constant signal power which can be used in transmitting a single signal.

Under (1), it was found that a) the Hamming code has a better noise immunity than the code with repetition and even protection for any probability of binary symbol distortion; and b) the Hamming code assures a better noise immunity than the simple binary code with $P \leq 0.3$ to 0.5. The gain obtained with the Hamming code declines with the rise of the number of transmitted messages.

Under (2) with normal fluctuation noise a) the Hamming code assures a higher degree of noise immunity than the code with repetition and even protection for any number of messages and any level of noise; b) for any noise level there exists a certain boundary value of the number of transmitted messages so that with a larger number of messages the Hamming code assures a better noise immunity than the ordinary binary code; in addition, the gain of the Hamming code grows with the growth of the number of transmitted messages; and c) a code with frequency features assures a better noise immunity than the Hamming code.

- 3) Ovseyevich, I. A., and M. S. Pinsker. Evaluation of carrying capacity of certain real communications channels. Radiotekhnika, v. 13, no. 4, 1958, 15-25. TK5700.R32, v. 13

Using the results of earlier investigations, an evaluation is made of the carrying capacity of 1) a real communications channel with parameters fixed over time; 2) a channel in which the parameters' changes over time have the appearance of white noise; and 3) a channel which is a combination of the first and second cases. It is demonstrated with examples that the results obtained are a generalization of known cases of E. D. Sunde* and J. Feinstein**.

In an earlier work*** the authors of this paper investigated the action of parametric phenomena in a communications channel on its carrying capacity in a general case, i.e., when no limiting conditions were superposed on the properties of the channel and of the noise acting in it. The evaluations obtained in that work and in the present one appear to be most efficient when the parametric effect is not large in comparison with the noise.

This evaluation will be particularly close to the exact value of the carrying capacity when in the channel passband the parametric effect has the appearance of Gaussian white noise.

1. *Evaluation of carrying capacity of a real communications channel with parameters fixed over time.*

The outgoing signal $\eta(t)$ may be expressed in the form

$$\eta(t) = [A\xi(t)]v(t) + \zeta(t) = \xi_1(t)v(t) + \zeta(t)$$

where $\xi(t)$ is the input signal; $\zeta(t)$ is noise acting in the channel; $v(t)$ is the parametric effect, all of these mutually independent, stationary random processes; and A is a linear operator.

The physical presentation of the process $v(t)$ arises naturally from the examination of a multitude of channels submitted for operation. Obviously, a precise determination and correction of attenuation and of phase characteristics of the channel is not realizable in practice. Some deviations from certain average characteristics will always exist, and since these deviations are induced by random causes, they will therefore differ from channel to channel. Since for the transmission of information between two points a variety of channels may be used, the selection of a given channel depends on chance, and the speed of transmission of the same input signal will be different in different channels.

* E. D. Sunde, BSTJ, No. 3-4, 1954

** J. Feinstein, J. Appl. Phys. 26, No. 2, 1955

*** Radiotekhnika, v. 12, No. 10, 1957

The characteristics of the random magnitude v , considered as an approximate presentation of the $v(t)$ process, may be obtained from the representation of the transmission coefficient as the sum of two components: one, identical for all channels and equal to the mathematical expectation of the transmission coefficient, and the other, random, resulting from the "fine-structure" imperfections of transmission characteristics.

In the final analysis, one obtains the following evaluation for the average carrying capacity of the channel with parameters fixed over time:

$$C \geq \frac{1}{4\pi} \int_{-W}^W \log \left[1 + \frac{\phi^2(\omega) f_{\xi\xi}(\omega)}{\phi^2(\omega) \sigma_v^2(\omega) f_{\xi\xi}(\omega) + f_{\zeta\zeta}(\omega)} \right] d\omega.$$

2. Evaluation of carrying capacity of a channel in which the parameter changes over time have the appearance of white noise.

In this case the carrying capacity of the channel is evaluated according to the formula:

$$C \geq \frac{1}{4\pi} \int_{-W}^W \log \frac{\phi^2(\omega) K}{2\pi P_c f_{vv} + f_{\zeta\zeta}(\omega)} d\omega.$$

3. Evaluation of carrying capacity of a real channel in which changes of the transmission coefficient over time have the appearance of white noise.

This case corresponds to a combination of the two preceding cases. We obtain the following evaluation:

$$C \geq \frac{1}{4\pi} \int \log \frac{K[\sigma_v^2(\omega) + \sigma_v^2(\omega)]}{K\sigma_v^2(\omega) + 2\pi f_{vv} P_c + f_{\zeta\zeta}(\omega)} d\omega.$$

4) Klyachkin, L. Z. Carrying capacity of binary pulse-code system with different probabilities of symbol distortion. *Radio-tekhnika*, v. 13, no. 4, 1958, 26-29. TK5700.R32, v. 13

The carrying capacity of a pulse-code system with binary code is determined in relation to the probability of distortion p during the reception of one symbol according to the formula:

$$C = 1 + p \log p + (1 - p) \log (1 - p) \frac{\text{binary units}}{\text{per symbol}} \quad (1)$$

(everywhere in this paper logarithms are with base 2).

However, in cases when probabilities of distortion during the reception of the symbol 0 and the symbol 1 are not identical, the formula (1) is not applicable. The speed of information transmission in binary units per symbol, obtainable in the above case, is expressed by the formula:

$$I = - \sum_x p(x) \log p(x) + \sum_y p(y) \sum_x p_y(x) \log p_y(x); \quad (2)$$

where $p(x)$ is the probability of appearance of a given symbol at the system input; $p(y)$ is the probability of appearance of a given symbol at the system output; and $p_y(x)$ is the *a posteriori* probability of appearance of a given symbol at the system input.

We designate the probability of distortion of the symbol 0 as p_a ; of the symbol 1 as p_b ; the zero repetition rate in source messages as p_0 ; evidently, the unit repetition rate at the input is $(1 - p_0)$.

The carrying capacity of the system with optimal repetition rate of zeros P_{0opt} is determined from the formula:

$$C = \log(1 + A) + \frac{p_b H(p_a) - (1 - p_a) H(p_b)}{1 - p_a - p_b}; \quad (3)$$

when $p_a = 1 - p_b$, $C = 0$; when $p_a = p_b = p$, then $P_{0opt} = 0.5$, and formula (3) coincides with (1).

The author investigates the dependence of carrying capacity on the level of fluctuation noise of a pulse-code modulation system in which the symbol 1 is transmitted by a radio pulse and the symbol 0 by a passive interval, and which has beyond the envelope detector any device with an operation threshold E_{Π} whose time is negligibly small in comparison with the duration τ of the position of one symbol. All possible arrangements of the position of one symbol are equally probable. Hence, by examining the process for a protracted time interval, e.g., for 1 sec, the probability of symbol 1 distortion can be determined from the relationship

$$p_b = \frac{\sum_{i=1}^{N(E_{\Pi})} [T_i - (e_i + \tau)]}{\sum_{i=1}^{N(E_{\Pi})} T_i} = \int_0^{v_{\Pi}} W_1(v) dv - W_1(v_{\Pi});$$

and the probability of symbol 0 distortion from the relationship

$$p_a = \int_{U_{\Pi}}^{\infty} W_0(v) dv + W_0(v_{\Pi}) = (1 + v_{\Pi}) e^{-\frac{v_{\Pi}^2}{2}}.$$