

Report No.
TDR-169(3713-01)TR-1

FOREWORD

This report was prepared for Applied Research Program Support.

63-4-2
①

408565

AD No.

FILE COPY

408565

408 565

A Survey of Some Plasma Acceleration Devices for Space Propulsion Applications

17 MAY 1963

*Prepared by D. M. DIX
Plasma Research Laboratory*

Prepared for COMMANDER SPACE SYSTEMS DIVISION

UNITED STATES AIR FORCE

Inglewood, California

JUL 12 1963
TISIA A



LABORATORIES DIVISION • AEROSPACE CORPORATION
CONTRACT NO. AF 04(695)-169

100

(18) (19)
SSD-TDR-63-120

(4) \$ 5.60
(5) 17 505

(14) Report No.
TDR-169(3713-01)TR-1

(6) A SURVEY OF SOME PLASMA ACCELERATION DEVICES
FOR SPACE PROPULSION APPLICATIONS,

(7) NA
(8) NA
(9) NA

(10)
Prepared by
D. M. Dix
Plasma Research Laboratory

(11) 17 May 63,

AEROSPACE CORPORATION
El Segundo, California

(12) 45P

(13) NA

(15) Contract No. AF 04(695)-169
6 ± ±

(16-17) NA

17 May 1963

(20) U.
21 NA

Prepared for
COMMANDER SPACE SYSTEMS DIVISION
UNITED STATES AIR FORCE
Inglewood, California

ABSTRACT

↓
The current status of pulsed plasma accelerators and steady-state $\underline{j} \times \underline{B}$ accelerators is summarized. Emphasis is placed upon three areas of the current state of knowledge: the basic interaction by which acceleration is accomplished; the loss mechanisms which exist in a given type device; and experimental results relevant to either of these two factors, as well as results of performance measurements. ↑

CONTENTS

I. INTRODUCTION 1

II. PULSED PLASMA ACCELERATION 3

 A. Basic Plasma Interaction 3

 B. Circuit Analysis of Efficiency 9

 C. Loss Mechanisms 13

 D. Concluding Remarks 16

III. DIRECT CURRENT ($\underline{j} \times \underline{B}$) ACCELERATORS 18

 A. Basic Plasma Interaction 18

 B. Loss Mechanisms and Operating Limitations 23

 C. Estimates of Performance versus Power Requirements ... 29

 D. Concluding Remarks 34

NOMENCLATURE 41

REFERENCES 43

FIGURES

1	Some Typical Geometries of Pulsed Plasma Accelerators	4
2	Qualitative Distribution of the Azimuthal Magnetic Field (B_{θ}) and Axial Electric Field (E_z) in a Coaxial Device	6
3	Equivalent Circuit of a Pulsed Plasma Accelerator	10
4	Two Types of $\underline{j} \times \underline{B}$ Accelerators	20
5	Configuration of Active Hall Accelerator (Ref. 16)	35
6	Magnetic Annular Arc (Ref. 24)	37

Tables

1	Loss Factors in $\underline{j} \times \underline{B}$ Devices	25
---	--	----

I. INTRODUCTION

This memorandum is devoted to a review of the current status of plasma propulsion, as it has been reported in the open literature. Plasma propulsion is here defined as the process of accelerating macroscopically neutral ionized gases by the application of electric and/or magnetic fields. As has been pointed out frequently in the past, the major application of such devices appears to be in the specific impulse (I_{sp}) range of 2000-5000 seconds. Further, it would appear that for space missions in the foreseeable future, such devices should perform with an overall efficiency (η) greater than 50% at power levels of the order of 10 kw or less. Hence, the aim of this review is to examine some existing types of plasma propulsion devices which may be capable of meeting the preceding requirements.

This summary is not intended to be exhaustive either in the number of references cited or in the number of devices discussed. The intent is rather to emphasize three areas in the current state of knowledge which bear heavily on the ultimate feasibility, or lack thereof, in a given device:

- 1) The basic plasma interaction by which acceleration is accomplished;
- 2) The various loss mechanisms which exist in a given type device; and
- 3) Experimental results relevant to either of the preceding factors, and results of performance measurements.

From a discussion of the above three areas, some rather general areas for further research present themselves, and they are accordingly briefly discussed; these of course represent opinions of the author.

It is pointed out that only two categories of plasma propulsion devices are discussed in detail; these are (1) pulsed plasma accelerators in which the current through the device interacts with the magnetic field produced by this same current to achieve acceleration, and (2) direct current ($\underline{j} \times \underline{B}$) accelerators. Other devices of course do exist; most notably the traveling wave type

devices. However, the mechanisms present in these type devices are very similar to one of the two types previously mentioned; further, there is very little experimental information available on these devices. The reader is referred to existing review articles (25, 26) for a detailed description of these devices.

II. PULSED PLASMA ACCELERATION

A. BASIC PLASMA INTERACTION

The basic mechanism of acceleration in this type device is that of the interaction of the current flowing in a plasma with the magnetic field produced by this current. A few of the geometries utilizing this interaction are shown in Figure 1; a more detailed description of devices of this type can be found in Reference 1. The simple coaxial geometry (Figure 1a) will be used as a basis for the following discussion, unless otherwise noted. The usual mode of operation of these devices is as follows: gas is admitted to the chamber, a capacitor bank is discharged through the gas (either by an external triggering device or by allowing the gas pressure to reach the breakdown point); this discharge is acted upon by the magnetic field produced by the current and is driven out of the accelerator. At any instant of time, the current path from the capacitor leads to the discharge is presumably through the conducting walls of the device, rather than through any gas left behind by the discharge. For detailed diagnostic purposes, operation in a single-shot mode is usually employed; to obtain significant thrust from a practical device, operation must be in the repetitively fired mode.

The details of the process by which current in the discharge produces acceleration in the gas have not as yet been completely understood. The devices investigated to date have operated in a regime where the parameter $(\omega\tau)_e$ is large compared to unity in the region of the discharge; this implies that the $\underline{j} \times \underline{B}$ force, which acts primarily on the electrons, is transmitted to the ions largely by electrostatic forces rather than elastic collisional processes. The necessary axial electric field (E_z) arises due to charge separation caused by the tendency of the $\underline{j} \times \underline{B}$ force to accelerate the electrons away from the ions.* The above discussion indicates that in the

*The possible mechanisms for transmitting the $\underline{j} \times \underline{B}$ force from electrons to other particles is discussed more fully in Section III of this report.

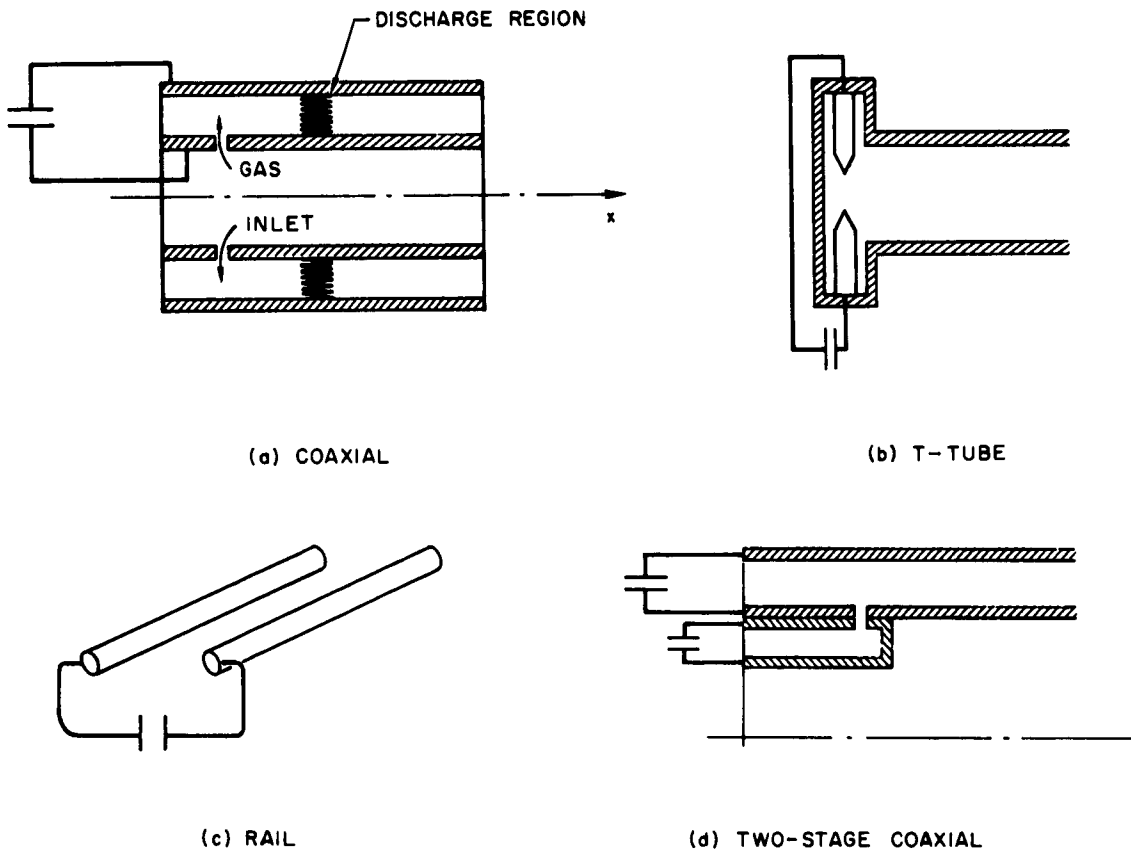

Fig. 1. Some Typical Geometries of Pulsed Plasma Accelerators

simplified one dimensional situation in Figure 2, it is expected that the E_z and B_θ profiles in the accelerator should be qualitatively as shown.

Several models for the basic acceleration process have been proposed, and none have proved completely adequate. In order to gain some insight as to what might be expected to occur in the acceleration process, the model wherein the discharge accelerates all of the gas preceding it to the discharge (current sheet) velocity will be described. It is emphasized here, and will subsequently be discussed, that this model is not adequate for describing the flow during the acceleration process; an understanding of the model does however yield an appreciation for the significance of the various physical quantities which are capable of observation. In this model, the region behind the current sheet contains no mass, no currents flow in the region, and hence the magnetic field, which is only in the azimuthal (θ) direction, must vary as $B_\theta \sim 1/r$, from Ampere's law. The axial force density (force per unit volume) acting due to the $\underline{j} \times \underline{B}$ force is given by:

$$f_z = \frac{\partial}{\partial z} \left(\frac{B_\theta^2}{2\mu_0} \right)$$

As this force is not uniform over the radius, being larger at the smaller radii, the gas would not be accelerated uniformly over the radius; the portion of the current sheet nearest the center would possess the highest velocity, while that portion nearest the outer radius would possess the least velocity. Obviously the current sheet would not remain in a radial plane. The integral $e \int E_z dz$ over the axial extent of the current sheet would represent the gain in energy of a singly charged ion in the direction of motion of, and relative to, the current sheet. Hence this integral would be equal to the incoming ion energy relative to the sheet, if the ion is to be accelerated to the current sheet velocity. The axial electric field is related to the axial force density by

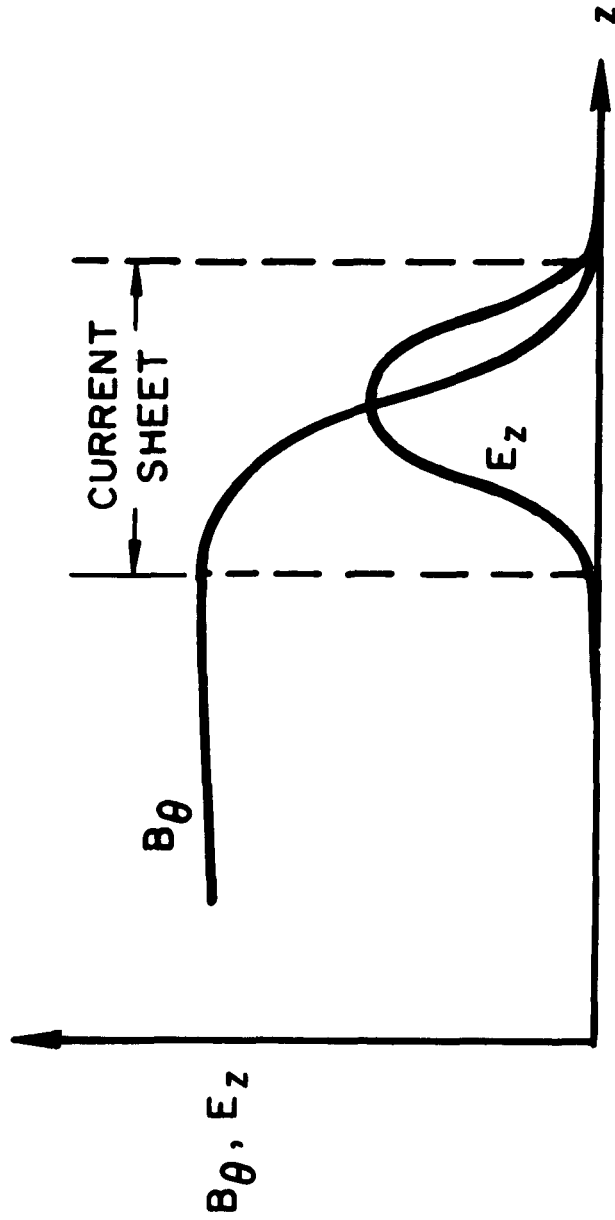

Fig. 2. Qualitative Distribution of the Azimuthal Magnetic Field (B_θ) and Axial Electric Field (E_z) in a Coaxial Device

momentum conservation:

$$n_i e E_z = f_z$$

which indicates that the E_z field should vary as r^{-2} .

Some progress has been made in experimental efforts to determine the details of the basic interaction between fields and plasma during the acceleration process, and merits discussion here. Lovberg and various co-workers (2-4) have made detailed probe measurements of the azimuthal magnetic field (B_Θ) and both axial and radial electric fields (E_z and E_r) in the simple coaxial geometry. Such measurements were used to deduce:

- 1) The instantaneous magnetic energy in the device:

$$\int (B_\Theta^2 / 2\mu_0) dV$$

where the integration is performed over the volume contained between the downstream end of the device and the position of the current sheet.

- 2) The axial force density acting on the plasma:

$$f_z = (\partial / \partial z) (B_\Theta^2 / 2\mu_0)$$

- 3) The ion number density:

$$n_i e E_z = f_z$$

- 4) The ion velocity:

$$m_i \Delta v_i = \int e E_z dt$$

where the integration is performed following the trajectory of a single ion.

- 5) The current sheet velocity.

Some of their more interesting observations and resulting conclusions were as follows:

- 1) The current sheet (discharge) remained in a radial plane (at least with the center electrode operated as a cathode). This immediately refutes the model previously discussed; since, in that case, the portion of the sheet nearest the center should move the most rapidly.
- 2) The axial electric field, E_z , varies slightly more rapidly than $1/r^2$, and the integral $e \int E_z dz$ near the cathode (the smallest radius) is approximately equal to the incoming ion energy measured relative to the current sheet. As discussed previously, this indicates that the ions in this region are being accelerated to the current sheet velocity by the axial electric field. The fact that E_z decreases with increasing radius indicates that the ions at the larger radii are not being accelerated to the full current sheet velocity.
- 3) The B_θ field does not vary as $1/r$ throughout the device. This is indicative of the presence of radial and/or axial currents in the channel.
- 4) At many operating conditions, the time-distance history of the current sheet is not consistent with the acceleration of all of the gas to current sheet velocity. Further, the ion velocity as deduced from the E_z measurements is generally less than the current sheet velocity. This of course indicates that the plasma velocity is not always equal to the velocity of the discharge, and further emphasizes the dangers in interpreting velocities obtained by optical techniques as plasma velocities.

It must be pointed out that the above observations were not all made on a single accelerator operating at the same conditions, nor were conditions systematically varied to determine the effect, if any, on the above observations.

It does seem clear, however, that significantly more experimental work, adequately supported by additional theory, is necessary before a satisfactory understanding of the acceleration process will be achieved. Further, as will be discussed subsequently, since no satisfactory efficiencies have as yet been obtained with this type of device, it appears that such an understanding will be necessary.

Lovberg and his coworkers (4) are presently continuing their probe measurements as well as other diagnostic techniques. However, there appears to be little effort being devoted elsewhere to a comparable detailed study of the fundamental processes involved.

B. CIRCUIT ANALYSIS OF EFFICIENCY

It is sometimes useful (but frequently misleading) to represent a pulsed plasma accelerator in terms of its equivalent electrical circuit, shown in Figure 3. Analyses of this type have appeared in many places (e. g. 5-8); some selected results will be discussed here. Referring to Figure 3, the instantaneous power supplied across the terminals of the capacitor may be written

$$P = I^2 R + \frac{d}{dt} \left(\frac{LI^2}{2} \right) + \frac{1}{2} I^2 \frac{dL}{dt}$$

where the three terms on the right side are respectively, power dissipated in resistive heating, power supplied to the magnetic field, and power supplied to the plasma via the Lorentz force. If it is now assumed that this latter term all goes into supplying directed kinetic energy to the plasma exhaust stream, then the expression for efficiency of acceleration of a single pulse can be written

$$\eta = \frac{\frac{1}{2} \int_0^t I^2 \frac{dL}{dt} dt}{\int_0^t I^2 R dt + \left(\frac{LI^2}{2} \right)_f + \int_0^t \frac{1}{2} I^2 \frac{dL}{dt} dt}$$

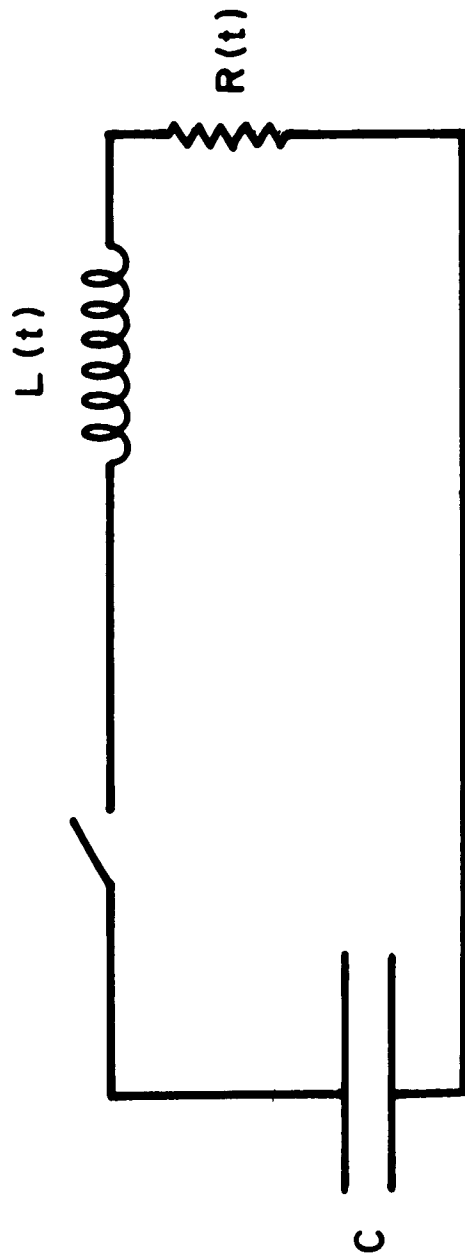

Fig. 3. Equivalent Circuit of a Pulsed Plasma Accelerator

where the subscript f denotes conditions at the time the current sheet leaves the accelerator, and the time interval for the integration is the time required for the current sheet to traverse the accelerator. If it is further assumed that $L' = dL/dx$ is constant as the discharge propagates along the device, then this expression may be written approximately.

$$\frac{1}{\eta} \approx 1 + \frac{2(LI^2)_f}{\langle I^2 \rangle L'v_e} + \frac{4R}{L'v_e}$$

where $\langle I^2 \rangle$ denotes the mean-square current over the pulse duration, and v_e is the velocity of the discharge at the exit of the device. This equation reveals that for high efficiency, the energy in the magnetic field should be negligible at the exit of the device and that the circuit resistance should be as small as possible, facts which are intuitively obvious. It further indicates the desirability of providing a large rate of change of inductance (L'). This may be interpreted physically as a statement that, for a given circuit resistance and discharge exit velocity, the shortest residence time of the discharge in the accelerator (which is inversely proportional to: the acceleration; the force acting on the plasma; and hence, L') will yield the highest efficiency (which is inversely proportional to: the total ohmic dissipation; and hence, the residence time). This fact has led to the development of the rail gun (5).

The preceding relation reveals no information pertaining to the length of the accelerator. However, it is easy to show from consideration of the rate of energy addition to the plasma that an upper bound for the efficiency is given by $\eta < L'L/L_0$, where L_0 is the initial inductance of the circuit and L is the accelerator length. Hence the final inductance of the circuit should be larger than the initial inductance, which merely reflects the fact that increasing the initial inductance reduces the rate of energy addition to the gas, and hence requires longer acceleration times and lengths. If it is further required that

the energy in the capacitor be either delivered to the plasma or dissipated by the end of the first half-cycle, then, approximately,

$$L \approx v_e \sqrt{(L_0 + L'L)C}$$

or, if $L_0/LL' \ll 1$,

$$L \approx L' C v_e^2$$

This relation is a reflection of the fact that increasing the electrical time constant requires longer accelerators, for a fixed discharge exit velocity.

Several factors bearing on the usefulness of analyses of the above type should be kept in mind. First, it has been assumed that the Lorentz force acting on the plasma produced only directed kinetic energy; this neglects any heating of the plasma or friction forces exerted on the plasma by the walls of the device. Hence the efficiency determined must be optimistic. Second, the relation between the velocity of the discharge at the exit of the device (v_e) to the velocity of the plasma has not been determined. This determination rests upon knowledge of the basic plasma interaction, which has been previously pointed out to be not satisfactorily understood. Models of this interaction employed to date [e. g., the "snowplow" model (12) and the "slug" model (6)] have generally assumed the discharge velocity and the plasma velocity to be equal, although Lovberg's results seem to indicate that this may not be the case. Third, the efficiency as calculated represents the actual conversion efficiency of the device only if all of the mass admitted to the device (in a single pulse) is accelerated by the discharge. Otherwise, the actual conversion efficiency will be reduced by the ratio of the mass of gas accelerated to the mass of gas admitted. Finally, all objections notwithstanding, analyses of this type do provide useful, qualitative scaling relations for these devices.

C. LOSS MECHANISMS

The ultimate fate of this type of accelerator (as well as all others) depends on how well the various loss mechanisms that are active in the acceleration process can be controlled. The following discussion is devoted to some of the important loss mechanisms that have been recognized to date.

1. Ohmic Dissipation in Capacitors and Transmission Lines

These losses can easily become excessive with improper design, and the design of a suitable, low weight capacitor with sufficiently low internal impedance, capable of operating at the repetition rates required represents a significant engineering problem (3). However, the solution appears to be one more of technique than principle and will not be considered further here

2. Ionization and Compressional, Shock, and Ohmic Heating in the Plasma

The losses due to ohmic heating do not appear to be excessive. Some measure of their magnitude has been obtained by Lovberg et al (3), in the coaxial geometry, by comparing measured values of the potential difference across the conducting walls of the device before and after the arrival of the discharge. The observed potential difference before the arrival of the discharge is merely the resistive drop across the plasma, including electrode voltage drops (based on the assumption that $B_{\theta} = 0$ ahead of the discharge in the coaxial geometry). After the arrival of the discharge, the observed potential difference is somewhat less than that occurring across the capacitor terminals. Lovberg's results indicate that the potential difference before discharge arrival is approximately 10% of that after arrival, and hence that these losses are small. Losses due to the fact that the plasma exhaust is almost fully ionized depend on the propellant employed; these losses can be easily estimated and do not appear to be significant for propellants other than hydrogen (provided that only single ionization occurs). The magnitude of compressional and shock heating depends on the details of the acceleration process; hence there exists no theory for estimating them. Experimental determination of these losses is equally difficult. However, it does not

appear reasonable that the thermal energy in the plasma exhaust should be a significant portion of the directed energy (which, for Argon at $I_{sp} = 3000$ seconds, is approximately 180 ev per electron-ion pair).

3. Discharge Initiation Losses

In a recent paper, Lovberg et al (8) present results of a detailed energy balance in the coaxial gun after the first quarter cycle of the discharge. The dominant feature of their results is that, at this time, approximately 25% of the energy supplied to the electrodes is in the form of magnetic field energy, a negligible amount is in directed plasma energy, and hence the remaining 75% is either in thermal energy in the plasma or has been lost (presumably by radiation and direct energy transfer to the walls). Their results further indicate that approximately 75% of the energy in the magnetic field eventually appears in the plasma exhaust. The energy dissipation in the initiation process is unexplained; Lovberg has speculated that this amount is fixed for given initial gas conditions, and hence that by increasing the energy supplied in the first half-cycle, a greater fraction may be invested in magnetic field energy.

4. Wall Losses

The walls of the device provide a means for direct energy transfer from the plasma; further, since the driving current passes through the electrodes, electrode erosion may also be a problem. To date, no theories have been advanced on the magnitude of direct energy transfer to the walls; further, no experimental determination of these losses has been made. Measurements of electrode erosion have been made [e.g. (5)] which indicate that operating conditions do exist for these devices wherein electrode erosion can be maintained at a tolerable level.

5. Propellant Utilization

In order to fully utilize the gas pulse injected, all of the gas should be accelerated to a uniform velocity. Any deviation from these conditions will result in a decrease in efficiency by the ratio of the mean velocity to the

root-mean-square velocity (when the means are taken over the pulse duration). Losses of this type arise due to several causes. First, if the driving force is not uniform over the cross-section of the accelerator (which it is not for all accelerators except a parallel plane geometry), it would be expected that the plasma would be accelerated non-uniformly. This problem would appear to be especially severe in devices of the rail type (Figure 1c; Reference 5). Second, prior to the discharge, a distribution of gas density exists along the accelerator length; if the discharge strikes such that an appreciable fraction of the gas pulse is upstream of the discharge, this fraction will of course undergo little acceleration. Overcoming this problem has been the primary motivation behind the two-stage coaxial gun (9, 10). Here it is hoped that the initial low power discharge will be sufficient to inject the propellant into the second stage in such a way that the main discharge accelerates all of the plasma. Of course, this problem may be less severe at high pulsing rates, a fact which remains to be investigated. Third, it has been observed by many investigators [e.g., (4)] that discharges in coaxial type devices tend to be unstable, and hence be non-uniform around the annulus ("spoking"). This leads to a disastrous non-uniform acceleration and heating of the plasma. Fortunately, it has been found (4) that operating conditions do exist where this instability does not occur, and the discharge is distributed uniformly. Finally, it has been found (4) that in many instances, a secondary discharge occurs near the upstream end of the accelerator before the main discharge has reached the accelerator exit (commonly called "crowbarring"). This results in trapped currents in the plasma, with attendant non-uniformities, as well as inefficient use of the energy remaining in the capacitors at the time the crowbar occurs. These various mechanisms emphasize the need for velocity and energy distribution determinations in the plasma exhaust; no reliable measurements have yet been reported.

D. CONCLUDING REMARKS

1. Performance of Existing Devices

As mentioned previously, the only positive measurement of efficiency of these devices which presently exists is via a direct measurement of thrust and mass flow. Very few such measurements have been publicly reported. Maes (5) reports an efficiency of 48% at $I_{sp} = 5000$ seconds for a rail device; the measurement is open to question, however, and has not been repeated. Gloersen, et al (9) report an efficiency of 32% at $I_{sp} = 5000$ seconds, 7 kw power level in a two-stage coaxial device. This determination relied on ballistic pendulum techniques, and hence cannot be fully accepted. The group at Republic Aviation have reported various efficiencies for their pinch engine, the most reliable appearing to be in the vicinity of 20%, at an $I_{sp} = 5000$ seconds (11). In sum, it appears that efficiencies greater than 25% in the I_{sp} range of interest have not yet been obtained.

2. Areas for Further Research

In addition to parametric studies of presently existing devices to determine the effect of operating parameters on efficiency, thrust, and specific impulse, it has become increasingly evident that work of a more fundamental nature is required. This statement is not intended to minimize the value of careful parametric studies, which will certainly yield useful information. However, in the absence of satisfactory performance, it appears that more detailed information on energy and momentum distribution and losses in the device will be required before the feasibility of pulsed plasma accelerators can adequately be assessed. It further appears that close coordination between experimental and theoretical efforts will be required. The areas for further work which logically present themselves from the preceding discussion are as follows:

- a) Development of an adequate description of the basic acceleration mechanism. Emphasis should be placed upon determining uniformity of acceleration, degree of ionization achieved, and energy supplied to thermal energy of the plasma versus energy supplied to directed kinetic energy.

- b) Determination of the loss mechanisms present in the discharge initiation process. From Lovberg's initial results, this appears to be of great importance. A parametric study of the magnitude of this loss as a function of operating conditions would be useful, as well as determinations of causes and magnitudes of energy losses. Theoretical work would also be desirable, and appears to be feasible.
- c) Detailed energy and momentum distribution measurements in the plasma exhaust.
- d) Study of the wall losses in the device (by complete calorimetry in pulsed operation, or otherwise).

It should be noted that no mention has been made of the engineering problems, particularly in the external circuitry, inherent in a practical device. These problems are not negligible, and probably should be approached concurrently with the study of the acceleration process proper.

III. DIRECT CURRENT ($\underline{j} \times \underline{B}$) ACCELERATORS

A. BASIC PLASMA INTERACTION

Viewed in a macroscopic sense, the basic acceleration mechanism in this type device is the Lorentz force acting on the plasma as a result of externally applied, crossed E and B fields. In all devices proposed to date, the driving current (i. e., that current which interacts with the applied magnetic field to produce a force in the direction of desired thrust) is carried primarily by electrons. There are two possible mechanisms by which this force can be transmitted to the ions and neutrals in the plasma (this force must be transmitted to the heavier particles if any significant thrust is to be achieved) and these lead naturally to two extremes of operation of such a device. The first mechanism by which the force can be transmitted is by elastic collision processes of electrons with the other particles. Inherent in this mechanism is of course some randomization (and hence thermal losses). The second mechanism by which force can be transmitted from electrons to ions only is via electrostatic fields. This force can further be transmitted to the neutral particles only by ion-neutral collisional processes.

Some appreciation for the manner in which these mechanisms evidence themselves can be gained by studying the generalized Ohm's Law, relating the current flow to the applied fields, for a gas containing electrons, ions, and neutral particles. In order to extract the salient features of this relation with a minimum of algebra, only the specialized case of an applied magnetic field in the z-direction and applied electric fields in the x- and y-directions will be considered. The motion of the gas is restricted to the positive x direction. In this special case, the x and y components of Ohm's Law (27) become:

$$j_x = \frac{\sigma(1 + \beta_e \beta_i f^2)}{(1 + \beta_e \beta_i f^2)^2 + \beta_e^2} \left(E_x - \frac{\beta_e E'_y}{1 + f^2 \beta_e \beta_i} \right)$$

$$j_y = \frac{\sigma(1 + \beta_e \beta_i f^2)}{(1 + \beta_e \beta_i f^2)^2 + \beta_e^2} \left(E'_y + \frac{\beta_e E_x}{1 + f^2 \beta_e \beta_i} \right)$$

where the Hall parameters $(\omega\tau)_e$ and $(\omega\tau)_i$ have been denoted by β_e and β_i , respectively, f is the ratio of neutral particle density to the neutral plus ion density, σ is the (scalar) electrical conductivity of the gas in the absence of a magnetic field, and $E'_y = E_y - uB_z$. It is pointed out that for fixed gas conditions, the parameters β_e and β_i increase linearly with applied magnetic field strength, B_z . The general features of these equations are: (1) the current does not flow entirely in the direction of the electric field, reflecting the physical tendency of a charged particle in crossed magnetic and electric fields to drift in a direction normal to both; and (2) for a fixed electric field, the current flow parallel to the electric field decreases as β_e increases, reflecting the physical tendency of a charged particle to spiral about the magnetic field lines, rather than drift across them. Three situations of different magnitudes of Hall parameter and applied fields (representing three different types of $\underline{j} \times \underline{B}$ acceleration) will now be discussed in detail.

1. Small Hall Parameter ($\beta_e \ll 1$)

The preceding equations reduce to $j_x = \sigma E_x$ and $j_y = \sigma E_y$ (it is to be noted that $\beta_i/\beta_e \approx (m_e/m_i)^{1/2} \ll 1$). These equations indicate that the current flows only in the direction of the applied electric field, and represent the physical situation where the $j_y B_z$ force is transmitted from the electrons to the heavy particles by elastic collisional processes.

Devices which operate in the regime $\beta_e \ll 1$ will be termed conventional accelerators, and a typical geometry with field orientations is shown in Figure 4a.

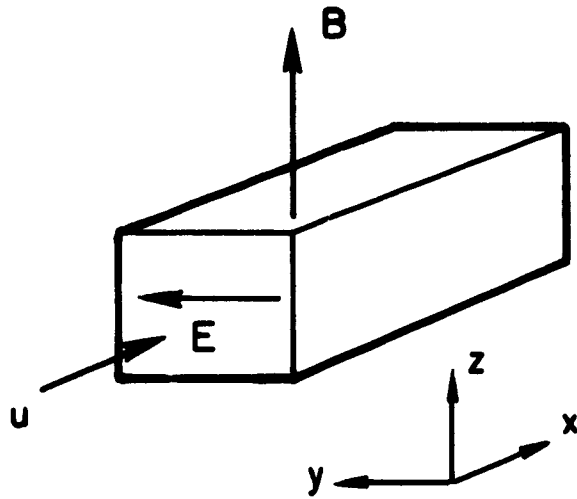

(a) CONVENTIONAL ACCELERATOR

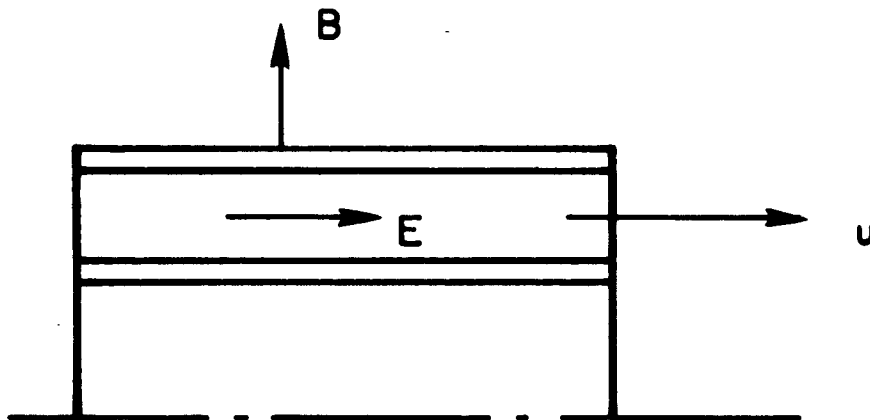

(b) COAXIAL ACTIVE HALL ACCELERATOR

Fig. 4. Two Types of $\underline{j} \times \underline{B}$ Accelerators

2. Zero Current in Direction of Gas Motion ($j_x = 0$)

In this case β_e is not assumed small, but it is required that the current in directions which do not contribute to acceleration in the direction of gas motion vanish. The current flow direction is then different from the direction of the applied electric field and the preceding equations reduce to $E_x = \beta_e E'_y / (1 + f^2 \beta_e \beta_i)$ and $j_y = \sigma E'_y / (1 + f^2 \beta_e \beta_i)$. This represents the physical situation where the $j_y B_z$ force acting on electrons is partially transmitted to the heavy particles by collisional processes and partially transmitted to the ions by an electrostatic field (E_x). This electrostatic field arises due to the fact that in its absence, the electrons would be accelerated by the $j_y B_z$ force away from the ions, and a current in the x direction would be produced. Hence, this field is just sufficient to ensure that the electrons and ions acquire the same drift velocity in the x-direction. It should also be noted that in the absence of the E_x field, the current j_y , for a fixed E'_y , is reduced by the factor $[1 + \beta_e^2 / (1 + f^2 \beta_e \beta_i)^2]$, so that for fixed gas conditions and E'_y , j_y decreases and j_x increases with increasing B_z . Finally, for $\beta_e \gg 1$, the electrostatic field is primarily responsible for transmission of the force from the electrons to the ions, and the force transmitted from electrons to neutrals becomes negligible. It is also pointed out that there is no energy addition associated with the E_x field; energy is supplied solely by the E_y field. In the regime $\beta_e \gg 1$, $\beta_i < 1$, where collisional processes are unimportant in determining electron motion, but are important in determining ion motion, the motion of the electrons can be qualitatively predicted by considering the motion of a single electron in the presence of the applied electric and magnetic fields. Since it is well known that a charged particle tends to drift in the $\underline{E} \times \underline{B}$ direction, the above process can be viewed in the equivalent sense that the largely transverse (y-direction) current flow is maintained by the electron drift arising from the crossed axial electric field (E_x) and the applied magnetic field (B_z).

Devices which operate in the regime of β_e not small, but $j_x = 0$ will be termed passive Hall accelerators. A typical geometry with field orientations is identical to that shown in Figure 4a, with the addition of an axial electric field in the positive x-direction. It is worth mentioning that if an ideal one-dimensional situation is visualized, in which there are no short-circuit current paths in the x direction, the E_x field would arise quite naturally from the tendency of the plasma to remain neutral (and hence $j_x = 0$). Physically, this condition would be achieved by the occurrence of a negative space charge sheath at the exit of the device and a similar positive space charge sheath at the entrance. The requirement of no short-circuited current paths in the x-direction is satisfied in practice by segmentation of the electrodes. It is to be noted that the driving current must pass through electrodes. Accelerators of this type have been investigated by Demetriades, et al, (17, 18) and Carter, et al, (19).

3. Zero Applied Electric Field in Direction of Driving Current ($E_y = 0$)

Again β_e is not assumed small, but it is required that $E_y = 0$ (hence eliminating the necessity of passing the driving current through electrodes). In this case, Ohm's Law reduces to

$$j_y = \frac{\sigma \beta_e}{(1 + f^2 \beta_e \beta_i)^2 + \beta_e^2} \left[E_x - \frac{(1 + f^2 \beta_e \beta_i) u B_z}{\beta_e} \right]$$

and

$$j_x = \frac{\sigma (1 + f^2 \beta_e \beta_i)}{(1 + f^2 \beta_e \beta_i)^2 + \beta_e^2} \left[E_x + \frac{\beta_e u B_z}{1 + f^2 \beta_e \beta_i} \right]$$

which indicates that for $\beta_e E_x$ sufficiently large and positive, $j_y > 0$, and hence acceleration of the gas will be achieved. Consider the coaxial geometry shown in Figure 4b, and assume that $\beta_e \gg 1$ and $\beta_i < 1$. The above equations

then represent the physical situation where the axial electric field, E_x , causes the electrons to drift in the azimuthal direction ($j_y > 0$) but are restricted from moving in the axial direction by B_z ($\beta_e \gg 1$), while the ions (and neutrals, by ion-neutral collisions) will be accelerated toward the cathode by E_x ($\beta_i < 1$). The azimuthal flow of electrons supplies the $\underline{j} \times \underline{B}$ force, in the sense that it causes, directly, the reaction on the accelerator. It should be noted that in the frame of reference of the accelerator, there exists a net ion flow in the positive x direction; to complete the required current flow it is necessary to supply electrons to the exhaust stream at the cathode. An important feature of this type of accelerator is that the driving current does not pass through electrodes.

Accelerators of this type will be termed active Hall accelerators. Investigations of devices of this type have been performed by Cann, et al, (16), Brandmaier, et al, (21), and Sevier, et al, (22).

In addition to the active Hall accelerator operating in a collision dominated mode, there exists the possibility of operating in a collisionless mode. This occurs if the ion cyclotron radius and the ion mean free path are larger than the characteristic accelerator dimension, while the electron cyclotron radius is much smaller than the characteristic accelerator dimension. The electrons behave in an identical manner as those in the collision dominated device; the ions, however, instead of being prevented from gyrating about the magnetic field lines by ion-neutral collisions, are now prevented from gyrating simply by the fact that the extent of the magnetic field is insufficient to support such motion. The ions are then accelerated electrostatically by the E_x field (since their motion is not impeded by collisions). This mechanism is of course feasible only with a gas which has a high degree of ionization. A device of this type has been investigated by Janes and Wilson (15).

B. LOSS MECHANISMS AND OPERATING LIMITATIONS

The loss mechanisms present in a $\underline{j} \times \underline{B}$ accelerator are essentially independent of the particular type of accelerator, although their magnitudes differ

in different types. Loss mechanisms in a constant area, constant temperature passive Hall accelerator have been discussed and crudely estimated by Janes and Fay (13) and further clarified by Janes (14). Of course, the constant area, constant temperature acceleration may not be the optimum method, but it is not likely to differ appreciably from it. A brief summary of these mechanisms is presented in the following paragraphs. Table I contains a summary of the estimates of the losses due to some of the mechanisms.

1. Hall Effect

The magnitude of the Hall effect (i. e., the tendency for current to flow in the $\underline{E} \times \underline{B}$ direction) is governed solely by the parameter $\beta_e = (\omega\tau)_e$. As discussed previously, if, in a conventional accelerator, this parameter becomes of order unity or greater, then to maintain the same $\underline{j} \times \underline{B}$ force density in the direction of gas motion, an appreciable current will flow in the direction of motion, which contributes greatly to Ohmic heating and contributes nothing to acceleration. Therefore, in conventional accelerators, $\omega\tau_e < 1$ for efficient operation. In passive Hall accelerators, $(\omega\tau)_e$ determines the magnitude of the axial electric field which must be maintained to prevent axial current flow. Although an upper limit for $(\omega\tau)_e$ is not clear, it appears that operation for $(\omega\tau)_e > 10$ would be extremely difficult (due to problems associated with segmentation of electrodes). In active Hall accelerators, the Hall effect provides the driving current and it therefore appears desirable to maintain $(\omega\tau)_e$ as large as possible, consistent with other limitations to be discussed.

2. Ion Slip

In Hall accelerators of either active or passive type operating with a partially ionized gas, neutral particles must be accelerated by collisions with ions. This results in heating, analogous to ohmic heating, and a difference between macroscopic ion and neutral velocities. This effect is observed in the generalized Ohm's Law by the term $f^2 \beta_e \beta_i$, which, loosely speaking, appears in the equation as a resistivity. In order to prevent this

Mechanism	Definition of Loss Factor	Loss Factor Estimate	Type of Device for which Estimate is Applicable
Thermal Leaving Loss	$\frac{\text{Thermal Energy in Exhaust}}{\text{Exhaust Kinetic Energy}}$	$\epsilon_L = \frac{2}{(\gamma - 1)M_e^2}$	All
Instantaneous Thermal Loss	$\frac{\text{Energy Supplied to Ohmic Heating}}{\text{Energy Supplied to Kinetic}}$	$f = \frac{\rho u}{2\sigma B^2 L}$	All
Frozen Flow Loss	$\frac{\text{Energy of Ionization and Dissociation}}{\text{Exhaust Kinetic Energy}}$	$\epsilon_{FF} = \frac{e^2 n_i}{2 m_i u^2} \left(\frac{1}{f} + \frac{1}{2} \right)$	All
Eddy Current Loss	$\frac{\text{Ohmic Heating by Eddy Currents}}{\text{Total Energy Supplied}}$	$\epsilon_{EC} = \frac{(1 + \Omega^2 \frac{w}{f})^2}{f} \frac{1}{L^2}$	Conventional Passive Hall
Electrode Voltage Drops	$\frac{\text{Heat Transfer to Electrodes}}{\text{Total Energy Supplied}}$	$\epsilon_E = \frac{\Delta V}{(1 + \Omega) B w}$	Conventional Passive Hall
Electrode Voltage Drops	$\frac{\text{Heat Transfer to Electrodes}}{\text{Total Energy Supplied}}$	$\epsilon_E = \frac{2e\Delta V}{m_i u^2}$	Active Hall
Viscous Boundary Layers	$\frac{\text{Heat Transfer to Walls}}{\text{Total Energy in Exhaust}}$	$\epsilon_{BL} = \frac{L}{w} \left(\frac{k_e}{\rho C_u u} \right)^{1/2}$	All, except Collisionless
Magnetic Boundary Layers	$\frac{\text{Heat Transfer to Walls}}{\text{Total Energy in Exhaust}}$	$\epsilon_B \approx \frac{1}{\sqrt{2\mu_0 \sigma u}} \left(\frac{L}{w} \right)^{1/2}$	All, except Collisionless
^a After James and Fay (13)			

Table 1. Loss Factors in $j \times B$ Devices^a

heating from becoming excessive, it can be shown (14) that the ion slip velocity must be small compared to the macroscopic velocity of the mixture, and leads to the requirement that $(\omega\tau)_e(\omega\tau)_i < 1$ for either type of accelerator. This particular limitation applies of course only to partially ionized gases. For a fully ionized gas in the collision dominated case, it is easy to see that if $(\omega\tau)_i$ becomes large, the ions will tend to drift in the $\underline{E} \times \underline{B}$ direction rather than be accelerated in the E_x direction; this yields an undesired acceleration of the gas in the $\underline{E} \times \underline{B}$ direction, and tends to reduce the driving current, and results in longer accelerators (thus increasing other losses). Although detailed computations have not been performed, it appears that the requirement $(\omega\tau)_e(\omega\tau)_i < 1$ is a reasonable one for avoiding the above effects. Finally, for active Hall accelerators operating in the collision free regime, the necessary requirements for operation are λ_i (the ion mean free path) $> L$, and γ_i (the Larmor radius of the ions) $> L$.

3. Anomalous (Bohm) Diffusion

It has been found that in plasmas in strong magnetic fields the mobility of electrons transverse to the field varies as B^{-1} instead of B^{-2} as would be predicted by the usual, steady theory. This indicates that the electron mobility is enhanced at these field strengths (believed to be due to some instability or turbulence mechanism). In Hall accelerators of either type, the reduction of electron mobility transverse to the magnetic field is an essential ingredient, and hence enhanced diffusion can seriously degrade performance (by virtue of the fact that the ability of the plasma to sustain an electric field transverse to the magnetic field is reduced). Qualitative evidence of enhanced diffusion in an active Hall accelerator operating in an ion collision free regime has been observed (15). Quantitative observations remain to be obtained.

4. Thermal Leaving Losses

By definition, these losses are due to the thermal energy in the exhaust stream. Without regard to the acceleration process, the requirement for low thermal losses imposes an upper limit to the exit temperature of a device

of given specific impulse. For a 3000 sec device utilizing a sodium propellant, the upper limit on temperature, is approximately 50,000°K to maintain these losses at 10%. The upper limit varies as I_{sp}^2 and directly with the molecular weight. The magnitude of these losses is of course governed by the acceleration process. If it is assumed that energy consumed in ohmic heating is not recovered, then it is necessary to maintain a small ratio of instantaneous ohmic heating to power supplied to directed kinetic energy ($j_{driving}/\sigma uB$). As shown in Table 1, this requirement indicates the desirability of high conductivity and field strength, and rather long accelerators ("gentle" acceleration). In principle, these losses could be partially recovered by expansion through a nozzle at the exit of the device; however, the losses associated with the additional surface area required are prohibitive.

5. Frozen Flow Losses

Considerations here are identical to those for any other type accelerator (e. g. , a small value for the ratio of energy invested in dissociation and ionization to the exhaust kinetic energy), and indicate the desirability of rather heavy, low ionization potential propellants. There appears to be no major difficulty in reducing these losses to tolerable levels.

6. Eddy Current Losses

These losses arise at entrance and exit of the device due to non-uniform electric and magnetic fields. As indicated in Table 1, these losses pose no difficulty as long as the length/width ratio of the channel is large. The result in Table 1 is not applicable to an active Hall accelerator, and perhaps the magnitude of these losses in this type accelerator merit further investigation.

7. Electrode Voltage Drops

These losses arise due to processes occurring in sheaths about the electrodes and evidence themselves as heat transferred to the electrodes. The physical processes are the same regardless of accelerator type; the magnitudes of the

losses are, however, vastly different for the different types of accelerators. The appropriate loss factor is merely the ratio of the total electrode voltage drop (usually of the order of 10-20 volts) to the total voltage across the electrodes. For conventional and passive Hall accelerators the result in Table I is a reasonable estimate and indicates the desirability of large magnetic fields and channel widths. For active Hall accelerators, the appropriate loss factor is merely the ratio of the electrode voltage drop to the exhaust energy of the ion. For any reasonable propellant, this ratio is quite small. This is the major advantage of active Hall accelerators compared to other types, as this loss mechanism is of primary importance in the latter. It should also be pointed out that the prediction of the magnitude of electrode voltage drops is not on a firm theoretical (or experimental) foundation, and merits further investigation.

8. Wall Losses

These losses, which arise via direct energy transfer from the plasma to the walls of the accelerator, in principle strongly depend on (1) whether the wall is an electrode or an insulator, due to the different relative orientation of the driving magnetic field, and (2) whether there is a magnetic field component parallel to the wall and in the direction of acceleration, of sufficient strength to dominate the development of the boundary layer ["magnetic containment" as defined in (14)] or the boundary layer is not influenced by a containing field ["viscous containment" in (14)]. In any case, the appropriate loss factor is taken as the ratio of the boundary layer thickness at exit to the channel width. The characteristics of these boundary layers have not as yet been worked out in detail (including the effects of the highly variable plasma properties), and undoubtedly merit further investigation. It appears, however, in the absence of more detailed calculations, that for viscous containment, the usual aerodynamic thermal boundary layer provides a crude estimate of the loss factor (hence this estimate is independent of whether the wall is an electrode or an insulator). As shown in Table I, these losses indicate the desirability of short accelerators with large cross-sections operating at high density (and hence high power levels). For magnetic

containment, the boundary layer thickness is determined by the rate at which mass moves toward the walls, normal to the containing field. The loss factor shown in Table I indicates the desirability of large magnetic Reynolds numbers (based upon accelerator width) and small length/width ratios. These results do not apply to the active Hall accelerator operating in the collision free regime, and no applicable estimates are currently available.

9. Uniformity of Current Density

In all accelerators it is necessary to maintain the current density reasonably uniform over the volume of the accelerator if efficient operation is to be obtained. There has apparently been very little work on this subject, although recent experiments with an active Hall accelerator (16) have indicated a tendency for the current to concentrate into regions of high current density. This effect should certainly be investigated more fully.

10. Other Losses

It is important to note that no consideration has been given to the power required to maintain the magnetic fields necessary for accelerator operation, nor the power required to produce the plasma which enters the accelerator. Both of these quantities may be important in a practical device; however, the losses mentioned previously seem to merit more immediate attention with the exception of the problem of plasma production in active Hall accelerators operating in the collision free regime. Unfortunately, no estimates are available on the magnitude of these losses. Further, radiation losses from the plasma could be appreciable; no consideration has been given here to these losses.

C. ESTIMATES OF PERFORMANCE VERSUS POWER REQUIREMENTS

1. Conventional and Passive Hall Accelerators

It is of keen interest to determine the power levels necessary for obtaining efficient operation of these accelerators. As it happens, these power requirements are determined, for fixed gas conditions, largely by the magnitudes of the electrode voltage drop and boundary layer losses. In order to arrive

at these requirements in a simple manner, it is convenient to consider the power level required to obtain reasonable values for the instantaneous loss factor, f , and the electrode voltage drop loss factor, ϵ_E . The power in the exhaust stream ($P = 1/2 \rho_e u_e^3 w^2$) may be written in terms of these loss factors and the channel width, w , as (utilizing the results presented in Table 1):

$$P = \frac{w(\Delta V)g_{sp}^2 I_{sp}^2}{2(1+f)\alpha_{\omega\tau}\epsilon_E}$$

where $\alpha_{\omega\tau} = B/\rho$ and is a function of gas properties and applied magnetic field strength and is directly proportional to $(\omega\tau)_e$. Typical values of this parameter are:

$$\alpha_{\omega\tau} = 50(\omega\tau)_e \text{ for } \underline{\text{He}}, 10,000^\circ\text{K, slightly ionized}$$

$$\alpha_{\omega\tau} = 10^3(\omega\tau)_e \text{ for } \underline{\text{Na}}, 10,000^\circ\text{K, fully ionized.}$$

It should be emphasized that, for slightly ionized gases, the coefficient of $(\omega\tau)_e$ is inversely proportional to the molecular weight and that this is the only gas property on which the coefficient depends. Similarly, for fully ionized gases, this coefficient is proportional to $T^{-3/2}$ and inversely proportional to the molecular weight.

The preceding relation for the power requirement states that, for a fixed electrode voltage drop, instantaneous thermal loss factor, and specific impulse, the power level increases with decreasing electrode voltage drop loss factor and increasing channel width, and decreases with increasing $\alpha_{\omega\tau}$. These effects can easily be deduced physically by interchanging P and ϵ_E (i. e., considering the equation as yielding ϵ_E as a function of w , $\alpha_{\omega\tau}$, and P): (1) for fixed values of $\alpha_{\omega\tau}$ and P , changing w requires $\rho \sim w^{-2}$ (since $P = \text{constant}$) and $B \sim \rho$ (since $\alpha_{\omega\tau} = \text{constant}$); hence the product wB (which is

proportional to the total voltage drop across the channel, and therefore inversely proportional to ϵ_E varies as w^{-1} , so that $\epsilon_E \sim w$; (2) for fixed w and $a_{\omega\tau}$, changing P requires $\rho \sim P$ (since $w = \text{constant}$), $B \sim \rho$ (since $a_{\omega\tau} = \text{constant}$), and hence $\epsilon_E \sim B^{-1} \sim P^{-1}$; (3) for fixed w and P , $\rho = \text{constant}$, so that changing $a_{\omega\tau}$ requires $B \sim a_{\omega\tau}$, and hence $\epsilon_E \sim a_{\omega\tau}^{-1}$.

It is evident that to obtain a given value of ϵ_E for minimum power expenditure, a minimum value of w and a maximum value of $a_{\omega\tau}$ are desired. Typical power requirements for a practical device can then be estimated as follows. If it is required to maintain the loss factors at 0.10, and an electrode voltage drop $\Delta V = 10$ volts is assumed, then, for $I_{sp} = 3000$ sec, $P \approx 5 \times 10^{10} w / a_{\omega\tau}$. If it is further required that $w \geq 10^{-3}$ m as a practical lower limit (which is very optimistic) $P \approx 5 \times 10^7 / a_{\omega\tau}$ watts. Then for slightly ionized helium operated at the maximum permissible value of $(\omega\tau)_e = 10$, $P \geq 100$ kw. Since for a fixed $(\omega\tau)_e$, $a_{\omega\tau}$ depends only on the gas molecular weight, this result is typical of all slightly ionized gases; * that is, the device must operate at very high power levels. It must therefore be concluded that, due to the necessary high power levels, accelerators of this type utilizing slightly ionized gases have no application in space propulsion in the near future, unless some method for pulsed operation is devised.

If now operation of these type accelerators with a fully ionized gas (e. g. , sodium at $10,000^\circ\text{K}$) is considered, the power relation for $\epsilon_E = f = 0.10$, $I_{sp} = 3000$ sec, $w = 10^{-3}$ m, and $(\omega\tau)_e = 10$ yields $P \gtrsim 5$ kw. This lower power requirement is due solely to the increased value of $a_{\omega\tau}$ (thus permitting a higher magnetic field strength for a given density) for the fully ionized gas. For a more realistic channel width of 10^{-2} m, this power would be raised by a factor of ten. Again, this result is typical for any fully ionized gas, due to the insensitivity of $a_{\omega\tau}$ to gas properties, and it thus appears

* Actually, for any other feasible propellant, the minimum power level would be higher, due to the higher molecular weight.

(since consideration of boundary layer losses does not affect the minimum power requirement, as will be discussed subsequently) that conventional and passive Hall accelerators utilizing a low-temperature, fully ionized gas may be made to operate efficiently at power levels of the order of 10-50 kw. If operation at higher values of $(\omega\tau)_e$ can be achieved, then this minimum power level may be lower. Of course, it must be emphasized that these conclusions assume that other loss mechanisms are not important, and in the case of anomalous diffusion and current density uniformity, this assumption is questionable.

The power requirement can also be written in terms of the aerodynamic boundary layer loss factor, in a manner completely similar to the preceding treatment of the electrode loss factor; the resulting relation is

$$P = \frac{wg^3 I_{sp}^3}{2f^{1/2} a_{\omega\tau} \epsilon_{BL}} \left(\frac{k_e}{2C_{P\sigma}} \right)^{1/2}$$

in which P possesses the same dependence on w , $a_{\omega\tau}$, and ϵ_{BL} as, in the previous relation, it had on w , $a_{\omega\tau}$, and ϵ_E , respectively. Again this dependence can be easily deduced physically by interchanging P and ϵ_{BL} : (1) for fixed values of $a_{\omega\tau}$ and P, changing w requires $\rho \sim w^{-2}$ (since P = constant), $B \sim \rho$ (since $a_{\omega\tau}$ = constant), and $L \sim B^{-1}$ (since f = constant), hence, since $\epsilon_{BL} \sim L^{1/2}/\rho^{1/2}w$, $\epsilon_{BL} \sim w$; (2) for fixed values of w and $a_{\omega\tau}$, changing P requires $\rho \sim P$ (since w = constant), and $B \sim \rho$ and $L \sim B^{-1}$ as before, hence $\epsilon_{BL} \sim L^{1/2}/\rho^{1/2} \sim P^{-1}$; (3) for fixed values of P and w , ρ = constant, so that $B \sim a_{\omega\tau}$, $L \sim B^{-1} a_{\omega\tau}^{-1}$ (since f = constant), hence $\epsilon_{BL} \sim L^{1/2} \sim a_{\omega\tau}^{-1}$. Again, for a minimum power requirement, a minimum w and maximum $a_{\omega\tau}$ are desired. For the regimes of interest, this relation yields a minimum power level of the same order of magnitude as the previous requirement for low electrode voltage drops (e. g., for fully ionized sodium at the same conditions used previously, $P \gtrsim 4$ kw for $\epsilon_{BL} = 0.1$) and hence merely re-emphasizes the previous conclusions.

Finally, it should be mentioned that the power requirements for magnetic containment are considerably higher (a few orders of magnitude) than those for viscous containment, and hence magnetic containment is of no aid in reducing the minimum power level required.

2. Active Hall Accelerators

In accelerators of this type, electrode voltage drop losses do not appear to be of prime importance, due to the fact that the driving current does not pass through electrodes. For operation in the ion-neutral collision dominated regime, the boundary layer losses are, however, essentially the same magnitude as in the conventional accelerator. Hence, for partially ionized gases, the minimum power levels are of the order of hundreds of kilowatts, and as such are too high for space propulsion applications (in the absence of some form of pulsed operation). For operation with a low temperature, fully ionized gas, the minimum power level again appears to be 10-50 kw, with the additional advantage that operation at higher values of $(\omega\tau)_e$ would reduce this level. It is pointed out that the difficulties associated with operation at high $(\omega\tau)_e$ are not as severe as in the passive type, due to the absence of electrodes parallel to the voltage gradient.

In active type accelerators operating in the collision free regime, no estimates of the wall losses are available. A very crude estimate of these losses would appear to be the ratio of the transit time of an ion in the accelerator to the time required for an ion to traverse the channel width at the local speed of sound, since this ratio is a measure of the fraction of ions which would lose their energy to the wall; thus $\epsilon = L/wM$. These losses again seem to indicate that efficient operation in the 10-50 kw is feasible at $(\omega\tau)_e = 10$, and at lower power levels for higher values of $(\omega\tau)_e$. Obviously, the actual magnitudes of these losses are worthy of further investigation.

It should be emphasized again that the presence of anomalous diffusion can severely degrade the performance of this device.

D. CONCLUDING REMARKS

1. Experimental Results

Experimental efforts in $\underline{j} \times \underline{B}$ accelerators have generally been of the nature of demonstrating that some plasma acceleration is achieved, rather than either definite measurement of performance or detailed study of the loss mechanisms present. Ragusa and Baker (20) performed some preliminary experiments in a conventional accelerator at power levels of approximately 3 kw and very low I_{sp} , and hence are of little interest. Carter et al (19) worked with a passive Hall acceleration at power levels of approximately 2.5 kw and very low I_{sp} . Demetriades et al (17, 18) performed experiments with a passive Hall accelerator utilizing partially ionized argon. The power level was from 50 kw and up, and efficiency of approximately 50% at $I_{sp} \lesssim 1000$ sec have been reported. Although these measurements are open to some question due to difficulties in thrust measurement, the results are in accord with the crude estimates presented in the previous paragraphs, since the power level required varies at least as I_{sp}^2 , and possibly as I_{sp}^3 . In a later paper (18), some attention was given to electrode voltage drop losses (measured by calorimetry techniques), and it was found that these were much larger than the boundary layer losses; this conclusion is also in agreement with the previous estimates, due to the low level of specific impulse (~ 750 sec) attained in the experiments.

Active Hall accelerators operating in the ion-neutral collision dominated regime have been experimentally investigated by Brandmaier et al (21) and Cann et al (16). In the former, the power level was approximately 1 kw and little useful information has been obtained as yet. In the latter investigation, two configurations were employed; one corresponded to the annular configuration of Figure 4b (with a cusped radial field, see Figure 5), while the other was with a cylindrical configuration (by removing the inner cylinder of the annular geometry). Power levels were of the order of 25 kw and the propellant was argon, supplied by an arc jet. Results with the cylindrical geometry indicated little acceleration, and this was attributed to the fact

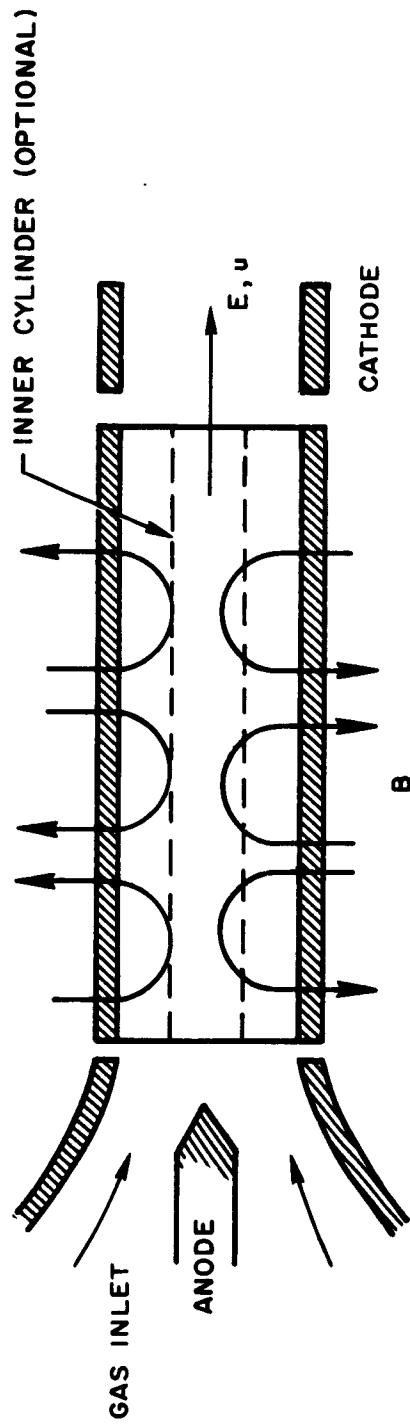

Fig. 5. Configuration of Active Hall Accelerator (Ref. 16)

that since the magnetic field vanished along the centerline of the device, electron currents could flow and hence the plasma would not sustain an electric field. Results with the annular geometry produced plasma acceleration, although the resulting efficiency was of the order of 10%. Although the principal components were water cooled, no mention was made of the heat transfer to these components.

Janes and Wilson (15) have investigated the active Hall accelerator operating in the collision free regime. Again, both the annular geometry of Figure 4b, (with a cusped radial field) and the corresponding cylindrical geometry (with inner cylinder of annular configuration removed) were employed. The propellant employed was argon, approximately 50% ionized, and was obtained from the discharge between anode and cathode. Power levels were of the order of 800 watts. Efficiencies obtained were of the order of 7% and specific impulses reached 1100 sec. Operation with the annular configuration produced greater voltage gradients, as expected, but the efficiency decreased and great difficulty was encountered in maintaining the discharge. This indicates that the benefits obtained from preventing axial electron flow were more than offset by increased losses due to the presence of the inner cylinder (primarily due to decreased ionization efficiency and increased wall losses). Further, at higher values of magnetic field strengths, unexplained oscillations were observed in the voltage across the electrodes.

Finally, two other experimental efforts in the nature of $\underline{j} \times \underline{B}$ acceleration, but not precisely fitting the previously defined types should be mentioned. First, Hogan (23) conducted experiments by passing the test gas (argon) from a combustion driven shock tube through a conventional $\underline{j} \times \underline{B}$ accelerator, in unsteady operation. This allowed achievement of instantaneous power levels up to 10 mw. Energy conversion efficiencies greater than 40% but less than 60% were reported. Powers and Patrick (24) have investigated the properties of the arc discharge in the presence of a transverse magnetic field in the geometry shown in Figure 6. The principle of operation is to impart tangential velocity to the gas passing through the arc. Subsequent to the

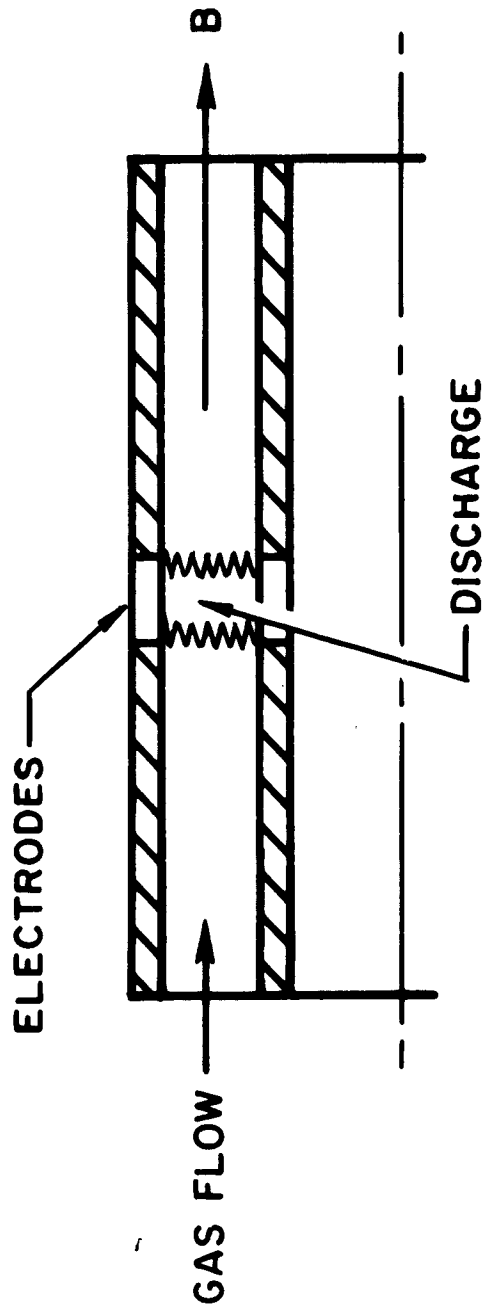

Fig. 6. Magnetic Annular Arc (Ref. 24)

tangential acceleration, it is envisioned by the authors that this energy will be redirected in an axial direction (by an unspecified process) and thus thrust will be obtained. Experiments were conducted utilizing both argon and helium as propellants, and evidence of such a velocity was found. However, when viewed end-on, the geometry of the applied fields and gas motion is identical to that of the conventional accelerator shown in Figure 4a. Hence the device should perform essentially as a conventional accelerator where the Hall currents are free to flow, and, from the previous discussion, efficient operation cannot be expected at low, or even moderate, power levels.

In summary, the following conclusions can be drawn from experiments to date with $\underline{j} \times \underline{B}$ accelerators:

- a) Results of experiments performed with partially ionized gases appear to be in accord with the estimates of Janes and Fay (13); i. e. with partially ionized gases, high power levels (>100 kw) are required for efficient operation.
- b) No experiments have been performed with a low temperature, fully ionized gas where estimates indicate possibility of efficient operation at moderate power levels (10-50 kw).
- c) Very little detailed study of the loss mechanisms has been attempted.

2. Areas for Further Research

From the preceding summary and discussion, it appears that the following areas of investigation are merited if the feasibility of $\underline{j} \times \underline{B}$ accelerators operating at moderate power levels (10-50 kw) or less is to be adequately assessed.

- a) Investigation of a $\underline{j} \times \underline{B}$ accelerator of the Hall type utilizing a fully ionized gas as a propellant. The most promising accelerator appears to be an active Hall accelerator operating in the collision free regime, since this circumvents electrode voltage drop losses and, in principle, allows operation at very high values of $(\omega\tau)_e$. Indeed, such devices are currently being investigated by Janes (15). In order to demonstrate the values of the relevant parameters in devices which may be expected to operate efficiently,

the following results of approximate calculations for fully ionized argon at 20,000°K and fully ionized sodium at 10,000°K are presented below.

	<u>Argon</u>	<u>Argon</u>	<u>Sodium</u>
I_{sp} (sec)	3000	3000	3000
$(\omega\tau)_e$	250	500	200
$(\omega\tau)_i$	1	2	1
Power (kw)	1.0	1.0	0.1
w(cm)	3.1	12.4	2.0
L(cm)	15.6	62	10.0
B (gauss)	400	50	380
$n_i(\text{cc})^{-1}$	2×10^{13}	10^{12}	8×10^{12}
$r_i(\text{cm})$	3.2	24	1.0

Due to the fact that these accelerators require an annular geometry, the channel width, w, in the above table is actually the square root of the cross-sectional area required. These results were obtained by assuming a value for the instantaneous thermal loss factor, $f = 0.1$, and assuming $L/w = 5$. Then, for specified values of power, specific impulse, and $(\omega\tau)_e$, the remaining quantities are completely determined. It should be pointed out that for fixed I_{sp} and f , the only way by which the ratio r_i/L can be increased is by increasing $(\omega\tau)_e$. The problem areas which appear to demand the most attention in such an investigation are:

- 1) Method (and efficiency) of producing a fully ionized plasma at the low densities required.
- 2) Detection of the presence of anomalous diffusion, and measurement of the effects produced.
- 3) Magnitude of wall losses.
- 4) Detection of nonuniformities (or instabilities) in the discharge, and measurements of the effects produced.

- b) As mentioned previously, the only method by which efficient operation in a passive Hall accelerator can be achieved at low overall power levels is by some form of pulsed operation. Hence, an investigation of pulsed operation may be desirable. However, the device then tends to resemble a pulsed plasma accelerator of the gun type, with all of the little understood difficulties. Any proposal of pulsed $\underline{j} \times \underline{B}$ accelerators must be examined carefully with respect to the similarities between the two devices.

NOMENCLATURE

<u>Symbol</u>	<u>Definition</u>
B	magnetic intensity
C	capacitance
C_p	specific heat at constant pressure
E	electric intensity
e	electronic charge
f	instantaneous thermal loss factor
f_z	axial force density
g	gravitational constant
I_i	ionization potential of species i
I_{sp}	specific impulse
j	current density
k	thermal conductivity
L	length of accelerator, inductance
M	Mach number
m	mass of particle
n	particle number density
P	power
r_i	Larmor radius of ion
u	plasma velocity
v_i	ion velocity
v_e	exhaust velocity of discharge

NOMENCLATURE (Continued)

<u>Symbol</u>	<u>Definition</u>
ΔV	voltage drop at electrodes
w	channel width
α_i	mole fraction of species i
β_e, β_i	Hall parameter for electrons and ions, $(\omega\tau)_e, (\omega\tau)_i$
γ	ratio of specific heats
ϵ	loss factor
λ_i	ion mean free path
σ	electrical conductivity
μ_0	permeability of free space
ρ	gas density
η	efficiency
$\omega\tau$	ratio of cyclotron frequency to collision frequency

Subscripts

B	magnetic boundary layer
BL	viscous boundary layer
e	electron, exit conditions
E	electrodes
EC	eddy current
FF	frozen flow
i	ion
L	exit losses.

REFERENCES

1. P. Gloersen, "Pulsed Plasma Accelerators," ARS Preprint 2129-61, October 1, 1961.
2. L. C. Burkhart and R. H. Lovberg, "Current Sheet in a Coaxial Plasma Gun," *Phys. Fluids* 5, 341 (1962).
3. R. H. Lovberg, B. R. Hayworth, and T. Gooding, "The Use of a Coaxial Plasma Gun for Plasma Propulsion," *General Dynamics/Aeronautics*, SSL-AE-62-0678, May 15, 1962.
4. R. H. Lovberg, B. R. Hayworth, and T. Gooding, "Coaxial Plasma Gun," Contract NAS-3-2501, *General Dynamics/Aeronautics*, AE 62-0775, 15 July 1962; AE 62-0927, 15 September 1962; AE 63-0080, 15 January 1962.
5. M. M. Maes, "Experimental Investigation of a Confined Parallel Rail Pulsed Plasma Accelerator," presented at Second Symposium on the Engineering Aspects of Magneto-hydrodynamics, 1962.
6. P. M. Mostov, W. L. Neuringer, and D. S. Rigney, "Electromagnetic Acceleration of a Plasma Slug" *Phys. Fluids* 4, 1097 (1961).
7. S. W. Kash, "Efficiency Considerations in Electrical Propulsion" in Plasma Acceleration ed. by S. W. Kash, Stanford University Press, 1960.
8. T. J. Gooding, B. R. Hayworth, and R. H. Lovberg, "Physical Processes in a Coaxial Plasma Gun," AIAA Preprint 63004, March, 1963.
9. P. Gloersen, B. Gorowitz, and W. A. Hovis, Jr., "An Investigation of the Properties of the Repetitively Fired Two Stage Coaxial Plasma Engine" G. E. Tech. Doc. R62SD28, April, 1962.
10. P. Gloersen, B. Gorowitz, H. E. Hall, and R. B. Thomas, Jr. "Repetitively Pulsed Two-Stage Plasma Propulsion Engine," Contract NAS-3-2502, First Quarterly Progress Report, 31 August 1962; Second Quarterly Progress Report, 30 November 1962.
11. Presentation by Republic Aviation Corporation to Aerospace Corporation, December, 1962.

REFERENCES (Continued)

12. W. McElroy and B. Siegel, "Analysis of Factors Influencing Plasma Engine Performance," Republic Aviation Corporation Report RAC 940, 1 October 1962.
13. G. S. Janes and J. A. Fay, "Magnetohydrodynamic Acceleration of Slightly Ionized, Viscously Contained Gases," presented at Second Symposium on Advanced Propulsion Concepts, Boston, Massachusetts 7-8 October, 1959.
14. G. S. Janes, "Magnetohydrodynamic Propulsion" Avco-Everett Research Laboratory RR 90, August, 1960.
15. G. S. Janes and T. Wilson, "Electrostatic Acceleration of Neutral Plasmas-Momentum Transfer Through Magnetic Fields," presented at the Third Symposium on Advanced Propulsion Concepts, Cincinnati, Ohio, 2-4 October, 1959.
16. G. L. Cann, R. W. Ziemer, and G. L. Marlotte, "The Hall Current Plasma Accelerator," AIAA Preprint 63011, March, 1963.
17. S. T. Demetriades and R. W. Ziemer, "Three Fluid Non-Equilibrium Plasma Accelerators" ARS Preprint 2375-62, March, 1962.
18. P. D. Lenn, J. R. Bodoia, D. L. Ward, G. L. Hamilton, and S. T. Demetriades, "Three Fluid Nonequilibrium Plasma Accelerators - Part II" AIAA Preprint 63047, March, 1963.
19. A. F. Carter, G. P. Wood, A. P. Sabol, and R. H. Weinstein, "Experiments in Steady State, High Density Plasma Acceleration," in Engineering Aspects of Magnetohydrodynamics ed. by C. Manna and N. W. Mather, Columbia University Press, 1962.
20. D. Ragusa and J. Baker, "Experimental Results with a Direct Current Electromagnetic Accelerator" in Engineering Aspects of Magnetohydrodynamics, ed. by C. Manna and N. W. Mather, Columbia University Press, 1962.
21. H. E. Brandmaier, J. L. Durand, M. C. Gourdine, and A. Rubel, "An Investigation of a One Kilowatt Hall Accelerator," AIAA Preprint 63046, March, 1963.
22. J. R. Sevier, R. V. Hess, and P. Brockman, "Coaxial Hall Current Accelerator Operation at Forces and Efficiencies Comparable to Conventional Crossed Field Accelerators," ARS Journal 32, 78 (1962).
23. W. T. Hogan, "Experiments with a Transient DC Crossed Field Accelerator at High Power Levels," presented at Third Symposium on the Engineering Aspects of Magnetohydrodynamics, 1962.

REFERENCES (Continued)

24. W. E. Powers and R. M. Patrick, "Magnetic Annular Arc" *Phys. Fluids* 5, 1196 (October, 1962).
25. G. R. Brewer, M. R. Currie, and R. C. Knechti, "Ionic and Plasma Propulsion for Space Vehicles," *Proc. of the IRE*, 49, 1789 (1961).
26. M. C. Gourdine, "Recent Advances in Magnetohydrodynamic Propulsion" *ARS Journal*, 31, 1670 (1961).
27. T. G. Cowling, Magnetohydrodynamics, Chapter 6, Interscience Publishers, Inc., New York, 1957.

UNCLASSIFIED	<p>Aerospace Corporation, El Segundo, California. A SURVEY OF SOME PLASMA ACCELERATION DEVICES FOR SPACE PROPULSION APPLICATIONS, prepared by D. M. Dix. 17 May 1963. [51] p. incl. illus. (Report TDR-169(3713-01)TR-1; SSD-TDR-63-120) (Contract No. AF 04(695)-169) Unclassified report</p> <p>The current status of pulsed plasma accelerators and steady-state j X B accelerators is summarized. Emphasis is placed upon three areas of the current state of knowledge: the basic interaction by which acceleration is accomplished; the loss mechanisms which exist in a given type device; and experimental results relevant to either of these two factors, as well as results of performance measurements.</p>	UNCLASSIFIED
--------------	---	--------------

UNCLASSIFIED	<p>Aerospace Corporation, El Segundo, California. A SURVEY OF SOME PLASMA ACCELERATION DEVICES FOR SPACE PROPULSION APPLICATIONS, prepared by D. M. Dix. 17 May 1963. [51] p. incl. illus. (Report TDR-169(3713-01)TR-1; SSD-TDR-63-120) (Contract No. AF 04(695)-169) Unclassified report</p> <p>The current status of pulsed plasma accelerators and steady-state j X B accelerators is summarized. Emphasis is placed upon three areas of the current state of knowledge: the basic interaction by which acceleration is accomplished; the loss mechanisms which exist in a given type device; and experimental results relevant to either of these two factors, as well as results of performance measurements.</p>	UNCLASSIFIED
--------------	---	--------------

UNCLASSIFIED	<p>Aerospace Corporation, El Segundo, California. A SURVEY OF SOME PLASMA ACCELERATION DEVICES FOR SPACE PROPULSION APPLICATIONS, prepared by D. M. Dix. 17 May 1963. [51] p. incl. illus. (Report TDR-169(3713-01)TR-1; SSD-TDR-63-120) (Contract No. AF 04(695)-169) Unclassified report</p> <p>The current status of pulsed plasma accelerators and steady-state j X B accelerators is summarized. Emphasis is placed upon three areas of the current state of knowledge: the basic interaction by which acceleration is accomplished; the loss mechanisms which exist in a given type device; and experimental results relevant to either of these two factors, as well as results of performance measurements.</p>	UNCLASSIFIED
--------------	---	--------------

UNCLASSIFIED	<p>Aerospace Corporation, El Segundo, California. A SURVEY OF SOME PLASMA ACCELERATION DEVICES FOR SPACE PROPULSION APPLICATIONS, prepared by D. M. Dix. 17 May 1963. [51] p. incl. illus. (Report TDR-169(3713-01)TR-1; SSD-TDR-63-120) (Contract No. AF 04(695)-169) Unclassified report</p> <p>The current status of pulsed plasma accelerators and steady-state j X B accelerators is summarized. Emphasis is placed upon three areas of the current state of knowledge: the basic interaction by which acceleration is accomplished; the loss mechanisms which exist in a given type device; and experimental results relevant to either of these two factors, as well as results of performance measurements.</p>	UNCLASSIFIED
--------------	---	--------------

	UNCLASSIFIED
	UNCLASSIFIED

	UNCLASSIFIED
	UNCLASSIFIED

	UNCLASSIFIED
	UNCLASSIFIED

	UNCLASSIFIED
	UNCLASSIFIED