

63-4-2

ASD-TDR-63-116

CATALOGED BY **DDC 776**  
AS AD NO. **408 776**

# Mechanical Properties of AM-350, Potomac A, Potomac M, and Vasco Jet-1000 Steel Alloys in the Annealed Condition

*Robert G. Henning, Capt, USAF*  
*Alton W. Brisbane*

TECHNICAL DOCUMENTARY REPORT NO. ASD-TDR-63-116

May 1963

**408 776**

Directorate of Materials and Processes  
Aeronautical Systems Division  
Air Force Systems Command  
Wright Patterson Air Force Base, Ohio

Project 7351, Task 735106

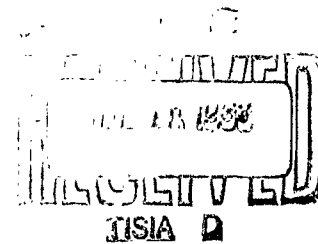

## NOTICES

When Government drawings, specifications, or other data are used for any purpose other than in connection with a definitely related Government procurement operation, the United States Government thereby incurs no responsibility nor any obligation whatsoever; and the fact that the Government may have formulated, furnished, or in any way supplied the said drawings, specifications, or other data, is not to be regarded by implication or otherwise as in any manner licensing the holder or any other person or corporation, or conveying any rights or permission to manufacture, use, or sell any patented invention that may in any way be related thereto.

Qualified requesters may obtain copies of this report from the Armed Services Technical Information Agency, (ASTIA), Arlington Hall Station, Arlington 12, Virginia.

This report has been released to the Office of Technical Services, U.S. Department of Commerce, Washington 25, D.C., in stock quantities for sale to the general public.

Copies of this report should not be returned to the Aeronautical Systems Division unless return is required by security considerations, contractual obligations, or notice on a specific document.

FOREWORD

This report was prepared by the Strength and Dynamics Branch. The work was initiated under Project No. 7351, "Metallic Materials," Task No. 735106, "Behavior of Metals." The work was administered under the direction of the Metals and Ceramics Laboratory, Directorate of Materials and Processes, Aeronautical Systems Division, with Captain Robert G. Henning acting as project engineer.

This report covers work performed during the period from June 1959 to June 1960.

The machining and testing of all specimens were accomplished under a routine testing contract AF 33(616) 6225, "Non-Research and Development Mechanical Properties Testing," by the Metcut Research Associates.

ABSTRACT

Mechanical properties of three hot-worked steels and one precipitation-hardening stainless steel were obtained. Properties obtained were tensile, compression, sheet single shear, bearing, and 105-degree-angle bend tests. Tests were conducted at temperatures of 80°, 400°, 600°, 800°, 1000°, and 1200°F. Stressed and non-stressed exposure tests were conducted only at 600°, 800°, and 1000°F. All properties were obtained from the longitudinal direction of the material except three tensile specimens from each material in the transverse direction, which were tested only at 80°F. Data obtained are presented graphically. Metallurgical histories and chemical analyses are also included.

This technical documentary report has been reviewed and is approved.



W. J. TRAPP  
Chief, Strength and Dynamics Branch  
Metals and Ceramics Laboratory  
Directorate of Materials and Processes

## TABLE OF CONTENTS

	Page
INTRODUCTION	1
TEST PREPARATION	1
Test Specimens	1
Chemical Analysis	1
Heat Treatment	2
MECHANICAL PROPERTIES MEASURED	2
TEST EQUIPMENT	3
Testing Machines	3
Extensometers and Test Fixtures	3
TEST CONDITIONS	3
TEST RESULTS	4
DISCUSSION	4
CONCLUSIONS	5

## LIST OF FIGURES

Figure	Page
1. Tensile Specimen	42
2. Compression Specimen	43
3. Sheet Shear Specimen	43
4. Sheet Bearing Test, Specimen-Bearing Ratio $e/D = 1.5$	44
5. Sheet Bearing Test, Specimen-Bearing Ratio $e/D = 2.0$	44
6. Sheet 105-Degree-Angle Bend Test Specimen	44
7. Specimen Layout Key for Sheets of Potomac A, Potomac M, and Vasco Jet-1000	45
8. Specimen Layout Key for Sheet of AM-350	46
9. Effect of Temperature on Tensile Properties of Potomac A	47
10. Effect of Temperature on Tensile Properties of Non-Stressed Stability Specimens, Potomac A	48
11. Effect of Temperature on Tensile Properties of Stressed Stability Specimens, Potomac A.	49
12. Effect of Temperature on Compressive Properties of Potomac A	50
13. Effect of Temperature on Bearing Properties of Potomac A	51
14. Effect of Temperature on Bearing Properties of Potomac A	52
15. Effect of Temperature on Shear Strength of Potomac A	53
16. Effect of Temperature on Tensile Properties of Potomac M	54
17. Effect of Temperature on Tensile Properties of Non-Stressed Stability Specimens, Potomac M	55
18. Effect of Temperature on Tensile Properties of Stressed Stability Specimens, Potomac M	56
19. Effect of Temperature on Compressive Properties of Potomac M	57
20. Effect of Temperature on Bearing Properties of Potomac M	58
21. Effect of Temperature on Bearing Properties of Potomac M	59
22. Effect of Temperature on Shear Strength of Potomac M	60
23. Effect of Temperature on Tensile Properties of AM-350	61
24. Effect of Temperature on Tensile Properties of Non-Stressed Stability Specimens, AM-350	62
25. Effect of Temperature on Tensile Properties of Stressed Stability Specimens, AM-350	63
26. Effect of Temperature on Compressive Properties of AM-350	64
27. Effect of Temperature on Bearing Properties of AM-350	65
28. Effect of Temperature on Bearing Properties of AM-350	66

## LIST OF FIGURES (Cont'd)

Figure	Page
29. Effect of Temperature on Shear Strength of AM-350	67
30. Effect of Temperature on Tensile Properties of Vasco Jet-1000	68
31. Effect of Temperature on Tensile Properties of Non-Stressed Stability Specimens, Vasco Jet-1000	69
32. Effect of Temperature on Tensile Properties of Stressed Stability Specimens, Vasco Jet-1000	70
33. Effect of Temperature on Compressive Properties of Vasco Jet-1000	71
34. Effect of Temperature on Bearing Properties of Vasco Jet-1000	72
35. Effect of Temperature on Bearing Properties of Vasco Jet-1000	73
36. Effect of Temperature on Shear Strength of Vasco Jet-1000	74
37. Effect of Exposure Time and Temperature Versus Non-Stressed Tensile Stability/Tensile Properties of Non-Exposed Potomac A	75
38. Effect of Exposure Time and Temperature Versus Non-Stressed Stability/Tensile Properties of Non-Exposed Potomac M	76
39. Effect of Exposure Time and Temperature Versus Non-Stressed Tensile Stability/Tensile Properties of Non-Exposed AM-350	77
40. Effect of Exposure Time and Temperature Versus Non-Stressed Tensile Stability/Tensile Properties of Non-Exposed Vasco Jet-1000	78
41. Effect of Exposure Time and Temperature Versus Stressed Tensile Stability/Tensile Properties on Non-Exposed Potomac A	79
42. Effect of Exposure Time and Temperature Versus Stressed Tensile Stability/Tensile Properties of Non-Exposed Potomac M	80
43. Effect of Exposure Time and Temperature Versus Stressed Tensile Stability/Tensile Properties of Non-Exposed AM-350	81
44. Effect of Exposure Time and Temperature Versus Stressed Tensile Stability/Tensile Properties of Non-Exposed Vasco Jet-1000	82
45. Effect of Temperature Versus the Compressive Properties/Tensile Properties of Potomac A	83
46. Effect of Temperature Versus the Compressive Properties/Tensile Properties of Potomac M	84
47. Effect of Temperature Versus the Compressive Properties/Tensile Properties of Potomac AM-350	85
48. Effect of Temperature Versus the Compressive Properties/Tensile Properties of Vasco Jet-1000	86
49. Effect of Temperature Versus the Sheet Shear Strength/Ultimate Tensile Strength of Potomac A	87

## LIST OF FIGURES (Cont'd)

Figure		Page
50.	Effect of Temperature Versus the Sheet Shear Strength/ Ultimate Tensile Strength of Potomac M	88
51.	Effect of Temperature Versus the Sheet Shear Strength/ Ultimate Tensile Strength of AM-350	89
52.	Effect of Temperature Versus the Sheet Shear Strength/ Ultimate Tensile Strength of Vasco Jet-1000	90
53.	Effect of Temperature Versus the Bearing Properties/ Tensile Properties of Potomac A, $e/D = 2.0$	91
54.	Effect of Temperature Versus the Bearing Properties/ Tensile Properties of Potomac M, $e/D = 2.0$	92
55.	Effect of Temperature Versus the Bearing Properties/ Tensile Properties of AM-350, $e/D = 2.0$	93
56.	Effect of Temperature Versus the Bearing Properties/ Tensile Properties of Vasco Jet-1000, $e/D = 2.0$	94
57.	Effect of Temperature Versus the Bearing Properties/ Tensile Properties of Potomac A, $e/D = 1.5$	95
58.	Effect of Temperature Versus the Bearing Properties/ Tensile Properties of Potomac M, $e/D = 1.5$	96
59.	Effect of Temperature Versus the Bearing Properties/ Tensile Properties of AM-350, $e/D = 1.5$	97
60.	Effect of Temperature Versus the Bearing Properties/ Tensile Properties of Vasco Jet-1000, $e/D = 1.5$	98
61.	Tensile Stress-Strain Curves of Potomac A	99
62.	Compression Stress-Strain Curves of Potomac A	99
63.	Tensile Stress-Strain Curves of Potomac M	100
64.	Compression Stress-Strain Curves of Potomac M	100
65.	Tensile Stress-Strain Curves of AM-350	101
66.	Compression Stress-Strain Curves of AM-350	101
67.	Tensile Stress-Strain Curves of Vasco Jet-1000	102
68.	Compression Stress-Strain Curves of Vasco Jet-1000	102

## LIST OF TABLES

Table		Page
1	Chemical Analysis of Test Materials	2
2	Average Tensile Property Ratios of Steel Alloys	6
3	Average Compressive, Bearing, and Shear Property Ratios of Steel Alloys	7
4	Tensile Properties of Potomac A (non-exposed specimens)	8
5	Tensile Properties of Potomac M (non-exposed specimens)	10
6	Tensile Properties of AM-350 (non-exposed specimens)	12
7	Tensile Properties of Vasco Jet-1000 (non-exposed specimens)	14
8	Tensile Properties of Potomac A (non-stressed stability specimens)	16
9	Tensile Properties of Potomac M (non-stressed stability specimens)	17
10	Tensile Properties of AM-350 (non-stressed stability specimens)	18
11	Tensile Properties of Vasco Jet-1000 (non-stressed stability specimens)	19
12	Tensile Properties of Potomac A (stressed stability specimens)	20
13	Tensile Properties of Potomac M (stressed stability specimens)	21
14	Tensile Properties of AM-350 (stressed stability specimens)	22
15	Tensile Properties of Vasco Jet-1000 (stressed stability specimens)	23
16	Sheet Shear Properties of Potomac A	24
17	Sheet Shear Properties of Potomac M	25
18	Sheet Shear Properties of AM-350	26
19	Sheet Shear Properties of Vasco Jet-1000	27
20	Compressive Properties of Potomac A	28
21	Compressive Properties of Potomac M	29
22	Compressive Properties of AM-350	30
23	Compressive Properties of Vasco Jet-1000	31
24	Bearing Properties of Potomac A ( $e/D = 1.5$ )	33
25	Bearing Properties of Potomac M ( $e/D = 1.5$ )	34

## LIST OF TABLES (Cont'd)

Table		Page
26	Bearing Properties of AM-350 (e/D = 1.5)	35
27	Bearing Properties of Vasco Jet-1000 (e/D = 1.5)	36
28	Bearing Properties of Potomac A (e/D = 2.0)	37
29	Bearing Properties of Potomac M (e/D = 2.0)	38
30	Bearing Properties of AM-350 (e/D = 2.0)	39
31	Bearing Properties of Vasco Jet-1000 (e/D = 2.0)	40
32	Bend Tests of Sheet Material Minimum Bend Diameter over 105-degree angle	41

## INTRODUCTION

Thermal environments, whether high or low, will cause changes in the mechanical properties of metals. The extent of such changes is directly proportional to the length of time exposed. This investigation involves the mechanical properties of four alloys designed for possible elevated temperature applications.

The effect of exposure time at test temperature on the elevated temperature tensile, compression, sheet single shear, bearing, and 105-degree-angle bend properties of Potomac A, Potomac M, Vasco Jet-1000, and AM-350 were determined.

## TEST PREPARATION

### Test Specimens

The materials used in these tests were considered representative of each type of material as consumer purchased.

All specimens were machined from 0.064-in. sheet material except the Vasco Jet-1000, which was 0.050-in. sheet. The standard 2-in.-gage-length, pinhole loading type of tension specimens were used (figure 1). Compression specimens  $2\frac{1}{2}$  in. x  $\frac{1}{8}$  in. were used (figure 2), and their ends were machined flat and parallel to each other. Sheet single shear specimens were machined as shown in figure 3. Figure 4 shows the shape of the bearing specimens which were machined to give an  $e/D$  ratio of 1.5, and figure 5, shows bearing specimen which give an  $e/D$  of 2.0. The bend specimens were 3 in. x 1 in. as shown in figure 6.

All test specimens were cut from the parent material so that the longitudinal axis of the specimen was parallel to the direction of rolling except three tensile specimens from each material, which were taken in the transverse direction and tested at room temperature.

The specimens were taken from the parent sheet as shown on the specimen layout in figures 7 and 8.

### Chemical Analysis

A chemical analysis of each material was made by the Bowser-Warner Testing Laboratories, Inc., Dayton, Ohio. The analysis is given in table 1.

TABLE 1  
CHEMICAL ANALYSIS OF TEST MATERIALS

<u>MATERIAL</u>	<u>SOURCE</u>	<u>C</u>	<u>Mn</u>	<u>Si</u>	<u>P</u>	<u>S</u>	<u>Cr</u>	<u>Ni</u>	<u>Mo</u>	<u>V</u>	<u>W</u>
AM-350	Allegheny-Ludlum	0.08	0.94	0.21	0.010	0.018	16.82	4.12	2.94	0.19	Trace
Potomac A	Allegheny-Ludlum	0.38	0.31	1.04	0.014	0.008	5.18	0.08	1.32	0.67	Trace
Potomac M	Allegheny-Ludlum	0.37	0.35	0.84	0.016	0.010	5.75	0.16	0.83	1.01	Trace
Vasco Jet-1000	Vanadium Alloys	0.36	0.38	0.88	0.013	0.010	5.48	0.05	0.89	0.61	Trace

### Heat Treatment

All specimens were tested in the annealed condition.

### MECHANICAL PROPERTIES MEASURED

The properties to be determined from the tensile tests were:

1. Ultimate tensile strength
2. Tensile yield strength (0.02- and 0.2-percent offset)
3. Elongation in 2-in. gage length
4. Modulus of elasticity

The properties to be determined from the compressive tests were:

1. Compressive yield stress (0.2-percent offset)
2. Modulus of elasticity
3. Secant modulus of 0.70 and 0.85

The properties to be determined from the bearing tests were:

1. Ultimate bearing strength
2. Bearing yield strength (2.0-percent of hole diameter)

The property to be determined from the sheet single shear tests was:

1. Ultimate shear strength

The property to be determined from the bending tests was:

1. Ratio of 105-degree-angle bending radius to thickness

## TEST EQUIPMENT

## Testing Machines

The tests were performed on both a Baldwin-Lima-Hamilton Model 60H hydraulic testing machine and a Southwork-Emery Universal testing machine. In addition to the 0-12,000 and 0-60,000 pound ranges which both machines have, the Baldwin-Lima-Hamilton machine has a 0-2,400 pound range and the Southwork-Emery machine a 0-1,200 pound range. Both machines are equipped with strain pacing devices and load strain recorders.

## Extensometers and Test Fixtures

A Baldwin-Lima-Hamilton PSH-8MS type of tensile extensometer was used in conjunction with an autographic recorder to measure strain for the tensile and sheet bearing tests. The sheet bearing loading shackles were self-aligning and were provided with means for adjusting the fit between the shackles and the specimen. The elevated temperature fixture, a Boeing Airplane Company design built by Metcut, was used for the compression specimen. A Baldwin-Lima-Hamilton P5-3M type of extensometer was used in conjunction with the autographic recorder to measure strain. (Evaluations for modulus of elasticity were obtained with autographic recording equipment due to the availability of the equipment. It is realized that the static modulus is affected by various test conditions and mechanical errors. Dynamic values would have been more accurate.)

## Elevated Temperature Furnace

A Marshall jacket type furnace having a temperature capacity of 1800°F was used for the tensile, single shear, and bearing tests. A "larger-diameter-split" type furnace was used for the compression tests. A resistance type of Metcut furnace was used for the elevated temperature bend test. Specimens that were exposed at elevated temperatures for 100 hours were placed in an air-circulating furnace.

## TEST CONDITIONS

Ten specimens of each material were tested at room temperature (80°F) and three at each of the following elevated temperatures, 400°, 600°, 800°, 1000°, and 1200°F. All tests were performed after a  $\frac{1}{2}$ -hr. hold at test temperature prior to testing. The maximum temperature variation along the gage length was  $\pm 5^\circ\text{F}$ .

Individual tests consisted of tensile, stability, compression, bearing, shear, and bend tests. In the tensile and compression tests, a constant strain rate of 0.005 in./in./min. was employed until tensile or compressive yield was attained. Then beyond the yield, a controlled head travel rate of 0.05 in./min. was maintained to failure. Stressed and non-stressed exposure tests were conducted to determine stability of the specimens. One-half were exposed under stress at 1/3 yield strength of the material; the other half were exposed in an unstressed condition. Compression tests were made, in which the 0.2-percent offset yield strength modulus of elasticity and stresses to produce the 0.7- and 0.85-secant moduli were determined. Shear tests were conducted at a head travel rate of 0.05 in./min. In the bend tests, the specimen was forced around progressively smaller and smaller radii to determine the minimum bend diameter to specimen thickness ratio at which specimen failure would not occur. In these, a loading rate of less than 1 in./min. was used.

## TEST RESULTS

The average and individual mechanical properties data from the tests obtained on all four materials are presented in tables 4 through 31. Averages of ultimate tensile, tensile yield, compressive yield, ultimate shear, bearing ultimate, and bearing yield property ratios are presented in tables 2 and 3. Curves showing averages of the mechanical properties versus test temperature are presented in figures 9 through 36, and ratio curves of these properties versus test temperature are presented in figures 37 through 60. Typical stress-strain curves for tension and compression tests of each material are given for each test temperature in figures 61 through 68.

## DISCUSSION

Since the four materials are of different compositions and processing no attempt will be made to compare one to the other except the Potomac A and the Potomac M.

From the graphs, the tensile ultimate and yield strengths of the Potomac A, Potomac M, and Vasco Jet-1000 materials varied very little in the 400°-800° temperature range, whereas the tensile ultimate and yield strengths of the AM-350 material varied little in the 400°-1000°F temperature range.

The non-stressed stability tensile test, as in the non-exposed tensile tests, showed negligible changes at the 600°, 800°, and 1000°F test temperature exposures. The stability tests of the Potomac A and Potomac M (after stress) showed nearly identical tensile and yield results. There was no appreciable change in the tensile and yield strengths of the AM-350 and Vasco Jet-1000 compared to the regular tensile tests. One notable point is that the tensile strength of the AM-350 alloy decreased 45 percent from room temperature to 400°F, but its tensile yield strength decreased 50 percent between room temperature and 1200°F.

The graphs show that the compressive yield strength of the Potomac A increased at 800° and at 1000°F for the 0.2-percent offset, 0.7-secant and 0.85-secant yields, and that the Potomac M had only a slight increase at the 800°F test temperature. The AM-350 alloy also had a yield strength increase at the 800°F test temperature. The Vasco Jet-1000 alloy had an increase in yield strength at 600°F temperature.

The graphs show that the bearing properties of the Potomac alloy seemed to decrease linearly between 400° and 600°F at the ratio of  $e/D = 1.5$ . Where  $e/D$  was 2.0, there was a slight increase at the 600°F test temperature. The bearing properties of the Potomac M alloy were approximately 7 to 10 percent higher than those of the Potomac A alloy. The same trend is noted for the ultimate bearing strength of the two alloys, for there is a large decrease in their ultimate strengths between room temperature and 400°F. The Vasco Jet-1000 alloy had a sharp rise in bearing yield at 600°F for both  $e/D$  of 1.5 and 2.0.

The data for the bend tests are given in table 32. No plot was made of this data. The ductility of the test material was such that no failures occurred. At all temperatures tested, the specimens were bent around a radius of 1/64 in. (i.e., 105-degree angle) without failure.

## CONCLUSIONS

There was very little change in the properties of the non-stressed and the stressed stability specimens which were held at test temperatures for 100 hours before testing. This indicates that the prestraining had only a thermal effect on the specimens.

Of the materials tested, the mechanical properties of the AM-350 alloy were the most affected.

Table 2  
Average Tensile Property Ratios of Steel Alloys

Alloy	Property Ratios (Longitudinal)	Average Tensile Property Ratios of Steel Alloys					
		Room Temperature Tests		Exposure Temperature Tests			
		600°F Exposure	800°F Exposure	1000°F Exposure	600°F Exposure	800°F Exposure	1000°F Exposure
Potomac A	Stability of Ultimate Tensile Strength, Stressed/Non-Exposed	1.00	1.00	0.96	0.89	0.82	0.55
Potomac M	" " " " " " " " " " " "	0.99	1.00	0.98	0.86	0.84	0.63
AM-350	" " " " " " " " " " " "	1.01	1.03	1.13	0.57	0.57	0.52
Vasco Jet-1000	" " " " " " " " " " " "	1.00	0.97	1.00	0.82	0.75	0.51
Potomac A	Stability of 0.02% Tensile Yield Strength, Stressed/Non-Exposed	1.16	1.26	1.02	1.00	0.81	0.60
Potomac M	" " " " " " " " " " " "	1.16	1.33	1.16	1.00	0.92	0.76
AM-350	" " " " " " " " " " " "	1.11	1.07	0.89	0.69	0.69	0.51
Vasco Jet-1000	" " " " " " " " " " " "	1.08	1.31	1.18	0.90	0.80	0.59
Potomac A	Stability of 0.2% Tensile Yield Strength, Stressed/Non-Exposed	1.08	1.08	0.94	0.93	0.83	0.62
Potomac M	" " " " " " " " " " " "	1.05	1.07	1.04	0.92	0.85	0.72
AM-350	" " " " " " " " " " " "	1.05	1.05	0.88	0.68	0.68	0.54
Vasco Jet-1000	" " " " " " " " " " " "	1.02	1.02	0.96	0.83	0.75	0.58
Potomac A	Stability of Ultimate Tensile Strength, Non-Stressed/Non-Exposed	1.00	0.98	1.00	0.91	0.83	0.56
Potomac M	" " " " " " " " " " " "	1.01	1.02	1.00	0.89	0.87	0.64
AM-350	" " " " " " " " " " " "	1.10	1.11	1.20	0.59	0.59	0.52
Vasco Jet-1000	" " " " " " " " " " " "	0.98	0.97	0.97	0.82	0.80	0.53
Potomac A	Stability of 0.02% Tensile Yield Strength, Non-Stressed/Non-Exposed	1.21	1.21	1.02	1.00	0.84	0.58
Potomac M	" " " " " " " " " " " "	1.24	1.28	1.26	1.02	0.94	0.78
AM-350	" " " " " " " " " " " "	1.11	1.11	1.07	0.67	0.73	0.49
Vasco Jet-1000	" " " " " " " " " " " "	1.13	1.10	0.95	0.90	0.85	0.64
Potomac A	Stability of 0.2% Tensile Yield Strength, Non-Stressed/Non-Exposed	1.08	1.07	0.96	0.92	0.86	0.62
Potomac M	" " " " " " " " " " " "	1.07	1.10	1.05	0.92	0.86	0.72
AM-350	" " " " " " " " " " " "	1.07	1.07	1.25	0.66	0.69	0.58
Vasco Jet-1000	" " " " " " " " " " " "	0.98	0.96	0.94	0.79	0.81	0.65

Table 3  
Average Compressive, Bearing, and Shear Property Ratios of Steel Alloys

Alloy	Property Ratio (Longitudinal)	Average Compressive, Bearing, and Shear Property Ratios of Steel Alloys							
		80°F	400°F	600°F	800°F	1000°F	1200°F		
Potomac A	0.2% Compressive Yield Strength/0.2% Tensile Yield Strength	0.79	0.68	0.71	0.67	0.65	0.36		
Potomac M	"	1.05	0.97	0.94	0.89	0.80	0.36		
AM-350	"	1.06	0.74	0.69	0.69	0.59	0.47		
Vasco Jet-1000	"	1.06	0.67	0.71	0.60	0.56	0.48		
Potomac A	0.7 Compressive Secant Strength/0.2% Tensile Yield Strength	0.58	0.50	0.51	0.55	0.55	0.33		
Potomac M	"	0.97	0.90	0.90	0.82	0.75	0.33		
AM-350	"	1.00	0.66	0.59	0.63	0.47	0.39		
Vasco Jet-1000	"	0.94	0.56	0.61	0.48	0.44	0.42		
Potomac A	0.85 Compressive Secant Strength/0.2% Tensile Yield Strength	0.44	0.40	0.40	0.50	0.47	0.30		
Potomac M	"	0.85	0.79	0.82	0.72	0.67	0.29		
AM-350	"	0.90	0.56	0.52	0.54	0.41	0.34		
Vasco Jet-1000	"	0.83	0.48	0.56	0.42	0.40	0.40		
Potomac A	Ultimate Shear Strength/Ultimate Tensile Strength	0.83	0.71	0.67	0.64	0.49	0.27		
Potomac M	"	0.92	0.77	0.75	0.71	0.59	0.33		
AM-350	"	0.94	0.49	0.45	0.44	0.39	0.33		
Vasco Jet-1000	"	0.85	0.72	0.68	0.61	0.49	0.30		
Potomac A	Bearing Ultimate Strength, (e/D = 2.0)/Tensile	1.63	1.50	1.48	1.36	1.08	0.65		
Potomac M	"	1.67	1.60	1.62	1.52	1.23	0.70		
AM-350	"	1.67	0.99	0.94	0.94	0.85	0.68		
Vasco Jet-1000	"	1.63	1.47	1.42	1.25	0.97	0.69		
Potomac A	Bearing Yield Strength, (e/D = 1.5)/0.2% Tensile Yield	1.75	1.61	1.60	1.55	1.22	0.72		
Potomac M	"	1.81	1.78	1.74	1.72	1.42	0.75		
AM-350	"	1.85	1.39	1.37	1.37	1.27	1.12		
Vasco Jet-1000	"	2.02	1.86	2.06	1.75	1.33	0.94		
Potomac A	Bearing (e/D = 2.0) Ultimate Strength/Ultimate Tensile Strength	2.07	1.90	1.91	1.79	1.37	0.75		
Potomac M	"	2.25	2.07	2.00	1.98	1.59	0.95		
AM-350	"	2.21	1.30	1.26	1.21	1.14	0.83		
Vasco Jet-1000	"	2.28	1.85	1.80	1.75	1.33	0.82		
Potomac A	Bearing Yield Strength, (e/D = 2.0)/0.2% Tensile Yield	1.96	1.80	1.86	1.83	1.43	0.75		
Potomac M	"	2.22	2.00	2.11	2.11	1.65	0.89		
AM-350	"	2.27	1.88	1.64	1.59	1.49	1.10		
Vasco Jet-1000	"	2.50	2.06	2.23	2.04	1.69	1.11		

Table 4  
Tensile Properties of Potomac A  
(Non-Exposed Specimens)

Specimen No.	Test Temp. (°F)	$U_{TS}$ , ksi	Yield Strengths (ksi) 0.02%	Yield Strengths (ksi) 0.2%	Elong. %	Modulus of Elasticity 10 <sup>6</sup> psi
A-1	RT	98.0	70.0	75.7	19.5	22.2
A-2	RT	97.5	52.1	73.0	20	30.4
A-3	RT	98.5	56.5	74.5	18	26.7
A-4	RT	97.5	66.5	71.0	20	23.9
A-5	RT	97.3	67.0	72.5	19.5	25.4
A-6	RT	97.0	64.3	70.3	19	22.6
A-7	RT	98.5	61.7	71.7	20	29.8
A-8	RT	98.0	64.5	74.0	20	26.1
A-9	RT	95.0	61.6	68.9	19.5	22.3
A-10	RT	97.2	61.0	71.0	18.5	25.5
Average		97.5	62.5	72.3	19.4	25.5
A-11*	RT	101	40.0	67.1	20	28.0
A-12*	RT	99.5	40.2	67.0	19.5	27.9
A-13*	RT	100	64.5	73.0	20.5	28.4
Average		100	48.2	69.0	20.0	28.1
A-14	400	87.2	58.4	68.2	16	25.7
A-15	400	87.7	53.4	65.3	16.5	28.7
A-16	400	86.5	43.6**	64.2	15.5	18.5
Average		87.1	55.9	65.9	16.0	24.3
A-17	600	86.4	61.2	68.8	13	21.9
A-18	600	86.0	55.3	63.8	13.5	22.8
A-19	600	86.2	58.5	65.8	14	16.2
Average		86.2	58.3	66.1	13.5	20.3
A-20	800	83.6	53.5	64.3	17.5	24.1
A-21	800	81.9	47.6	59.8	18	27.2
A-22	800	80.6	49.7	60.7	18.5	22.5
Average		82.0	50.3	61.6	18.0	24.6

\* Transverse specimen.

\*\* Not used in average.

Table 4 (Cont'd)  
Tensile Properties of Potomac A  
(Non-Exposed Specimens)

Specimen No.	Test Temp. (°F)	U. T. S. ksi	Yield Strengths (ksi) 0.02%	Yield Strengths (ksi) 0.2%	Elong. %	Modulus of Elasticity 10 <sup>6</sup> psi
A-23	1000	57.6	37.2	46.9	32	21.8
A-24	1000	58.8	37.6	47.2	21***	19.6
A-25	1000	56.5	35.8	45.8	30	20.8
Average		57.6	36.9	46.6	31	20.7
A-26	1200	37.0	20.7	23.0	34***	8.1
A-27	1200	31.7	14.6	20.7	41.5	11.0
A-28	1200	35.7	18.7	24.2	41.5	9.0
Average		34.8	18.0	22.6	41.5	9.4

\*\*\* Specimen broke outside of gage length.

Table 5  
Tensile Properties of Potomac M  
(Non-Exposed Specimens)

Specimen No.	Test Temp. (°F)	U <sub>T</sub> , S, ksi	Yield Strengths (ksi) 0.02%	Yield Strengths (ksi) 0.2%	Elong. %	Modulus of Elasticity 10 <sup>6</sup> psi
B-1	RT	95.5	51.2	68.5	17.5	26.7
B-2	RT	96.5	52.0	69.5	17	29.9
B-3	RT	98.1	55.6	72.8	16	26.5
B-4	RT	98.5	49.4	71.6	15	30.6
B-5	RT	99.5	57.3	72.0	14.5	28.1
B-6	RT	96.5	48.6	69.1	14.5	26.5
B-7	RT	100	56.0	75.4	16	31.1
B-8	RT	99.0	57.0	74.0	16	30.5
B-9	RT	99.0	59.0	74.0	15	24.9
B-10	RT	97.5	56.0	71.7	19.5	27.0
Average		98.0	54.2	71.8	16.1	28.2
B-11*	RT	101	63.2	78.1	12	31.1
B-12*	RT	102	70.1	82.8	11.5	32.1
B-13*	RT	104	75.5	83.7	12.5	30.9
Average		102	70.7	81.5	12.0	31.4
B-14	400	88.2	52.9	67.3	13	27.7
B-15	400	86.0	61.7	63.6	11.5	25.8
B-16	400	89.0	52.2	67.2	12.5	28.1
Average		87.7	55.6	66.0	12.3	27.2
B-17	600	84.1	49.0	66.0	12.5	22.8
B-18	600	86.2	50.9	64.8	12.5	22.0
B-19	600	84.0	51.2	65.4	12	22.7
Average		84.8	50.4	65.1	12.3	22.5
B-20	800	82.7	50.0	61.8	13.5	15.2
B-21	800	84.7	44.9	62.0	12	19.0
B-22	800	84.9	44.8	61.2	11	18.8
Average		84.1	46.6	61.7	12.2	18.0

\* Transverse specimen.

Table 5 (Cont' d)  
Tensile Properties of Potomac M  
(Non-Exposed Specimens)

Specimen No.	Test Temp. (°F)	U. T. S. ksi	Yield Strengths (ksi) 0.02%	Yield Strengths (ksi) 0.2%	Elong. %	Modulus of Elasticity 10 <sup>6</sup> psi
B-23	1000	61.3	38.7	49.7	13***	23.9
B-24	1000	64.4	37.8	50.5	20	20.0
B-25	1000	64.5	36.0	51.7	15.5	21.3
Average		63.4	37.5	50.6	17.8	21.7
B-26	1200	40.1	17.4	22.7	13***	10.9
B-27 (R)	1200	39.3	14.4**	23.3	21.0	10.1
B-28	1200	41.4	17.3	23.5	10***	9.9
Average		40.3	17.2	22.8	21.0	10.3

\*\* Value not used in average

\*\*\* Specimen broke outside of gage length, elongation data not used in averages.

Table 6  
Tensile Properties of AM-350  
(Non-Exposed Specimens)

Specimen No.	Test Temp. (°F)	U. T. S. ksi	Yield Strengths (ksi) 0.02%	Yield Strengths (ksi) 0.2%	Elong. %	Modulus of Elasticity 10 <sup>6</sup> psi
C-1	RT	154	48.7	62.5	44.5	22.2
C-2	RT	149	44.5	56.0	46	15.6
C-3	RT	150	44.5	60.4	44.5	-
C-4	RT	155	41.5	57.5	44.5	28.0
C-5	RT	155	44.0	58.0	47	21.7
C-6	RT	155	43.0	58.5	44	28.1
C-7	RT	162	45.0	60.0	43	26.6
C-8	RT	168	45.0	59.5	46	32.2
C-9	RT	164	50.0	60.0	48	27.9
C-10	RT	165	42.5	58.0	46	33.3
Average		158	44.9	59.0	45.4	26.2
C-11*	RT	150	44.0	61.5	39	27.4
C-12*	RT	152	47.0	62.5	42	24.2
C-13*	RT	156	46.5	64.0	41.5	24.4
Average		153	45.8	62.7	40.8	25.3
C-14	400	91.0	32.0	41.7	38	22.7
C-15	400	91.5	35.6	43.2	36	15.9
C-16	400	93.5	33.8	41.3	38.5	18.6
Average		92.0	33.8	42.1	37.5	18.9
C-17	600	90.8	31.8	38.9	38	22.2
C-18	600	90.4	32.4	40.2	35.5	21.5
C-19	600	91.0	30.2	38.9	36.5	24.0
Average		90.7	31.5	39.3	36.7	22.6
C-20	800	88.7	29.3	33.5	36.5	21.2
C-21	800	88.3	24.6	36.9	37	18.6
C-22	800	89.7	28.0	37.1	40	19.6
Average		88.9	27.3	35.8	37.8	19.8

\* Transverse specimen.

Table 6 (Cont'd)  
Tensile Properties of AM-350  
(Non-Exposed Specimens)

Specimen No.	Test Temp. (°F)	U <sub>T.S.</sub> ksi	Yield Strengths (ksi) 0.02%	Yield Strengths (ksi) 0.2%	Elong. %	Modulus of Elasticity 10 <sup>6</sup> psi
C-23	1000	81.2	26.5	32.4	32.5	19.1
C-24	1000	83.5	27.6	32.6	28 **	14.8
C-25	1000	81.7	24.3	32.7	29.5	21.7
Average		82.1	26.1	32.6	31.0	18.5
C-26	1200	61.1	23.0	29.9	19 **	11.8
C-27	1200	57.5	22.4	28.8	36	10.9
C-28	1200	58.2	20.2	28.8	34 **	12.7
Average		58.9	21.9	29.2	36.0	11.8

\*\* Specimen failed outside of gage length, elongation data not used in averages.

Table 7  
Tensile Properties of Vasco Jet-1000  
(Non-Exposed Specimens)

Specimen No.	Test Temp. (°F)	U. T. S. ksi	Yield Strengths (ksi) 0.02%	Yield Strengths (ksi) 0.2%	Elong. %	Modulus of Elasticity 10 <sup>6</sup> psi
D-1	RT	90.0	38.6	54.6	20.5	27.3
D-2 (R)	RT	98.0	43.0	54.0	18.5	27.1
D-3	RT	88.0	42.8	55.5	21	23.0
D-5	RT	87.7	43.5	53.5	19	27.6
D-5	RT	88.0	41.2	52.7	18	29.1
D-6	RT	87.9	39.8	50.4	19	28.8
D-7	RT	87.9	34.2	48.6	18	24.2
D-8	RT	91.2	34.5	51.7	18.5	18.5
D-9	RT	91.2	43.3	52.1	17.5	26.8
D-10	RT	90.9	34.2	50.8	18	34.2
Average		90.1	39.3	52.4	18.8	26.7
D-11**	RT	91.6	49.3	54.2	20.5	30.5
D-12**	RT	91.5	42.8	50.9	20.5	23.6
D-13**	RT	98.7	60.9*	68.0*	18.5	23.9
Average		93.9	46.1	52.6	19.8	26.0
D-14	400	75.7	29.4	41.1	14	28.9
D-15	400	80.0	34.7	44.8	16	19.3
D-16	400	78.2	35.1	43.2	15.5	23.3
Average		78.0	33.1	43.2	15.2	23.8
D-17	600	74.7	33.0	42.1	15.5	19.7
D-18	600	72.0	32.4	43.8	15.0	14.5
D-19	600	72.7	35.6	42.3	12.5	16.0
Average		73.1	34.4	42.9	14.3	16.7
D-20	800	70.0	29.4	37.8	15.5	29.2
D-21	800	67.7	36.6	41.8	17.5	7.9*
D-22	800	70.7	31.4	41.8	17.5	28.3
Average		69.5	32.5	40.5	16.8	28.8

\* Not used in average

\*\* Transverse specimen

Table 7 (Cont'd)  
Tensile Properties of Vasco Jet-1000  
(Non-Exposed Specimens)

Specimen No.	Test Temp. (°F)	U. T. S. ksi	Yield Strengths 0.02% 0.02%	Yield Strengths (ksi) 0.2%	Elong. %	Modulus of Elasticity 10 <sup>6</sup> psi
D-23	1000	47.8	24.8	32.7	21.5***	15.7
D-24	1000	46.0	25.4	32.4	27	21.6
D-25	1000	48.3	21.0	31.6	29.5***	27.6
Average		47.4	23.7	32.2	28.0	21.6
D-26	1200	29.8	17.4	22.3	13.5***	8.4
D-27	1200	28.9	16.4	20.4	26.5***	7.2
D-28	1200	32.2	17.4	23.3	14.5***	6.9
D-28 (R)	1200	28.2	-	-	35.0	-
Average		29.8	17.1	22.0	35.0	7.5

\*\*\* Specimen broke outside of gage length, elongation data not included in average  
- Data not obtained

Table 8  
Tensile Properties of Potomac A  
(Non-Stressed Stability Specimens)

Spec. No.	Exposure Temp. (°F)	Test Temp. (°F)	U <sub>1</sub> T. S. ksi	Yield Strengths 0.02% (ksi)	Elong. %	Modulus of Elasticity 10 <sup>6</sup> psi
A-29	600	RT	99.5	82.0	17	28.5
A-30	600	RT	93.4	69.0	17.5	25.7
A-31	600	RT	98.0	74.9	20	27.9
Average			97.0	75.3	18.2	27.4
A-32	600	600	89.4	65.5	16.5	29.1
A-33	600	600	88.0	60.8	15	28.7
A-34	600	600	87.7	59.3	16	30.1
Average			88.4	61.9	15.8	29.3
A-35	800	RT	99.1	81.4	18.5	28.7
A-36	800	RT	88.0	69.7	19.5	26.5
A-37	800	RT	97.4	74.1	19.5	29.9
Average			94.8	75.1	19.2	28.4
A-38	800	800	82.0	55.3	17	23.6
A-39	800	800	80.8	48.6	19	25.9
A-40	800	800	80.8	52.9	18.5	25.1
Average			81.2	52.3	18.2	24.9
A-41	1000	RT	98.0	61.3	20	35.5
A-42	1000	RT	96.5	65.2	20	28.3
A-43	1000	RT	96.0	63.8	17.5	35.2
Average			96.8	63.2	19.2	33.0
A-44	1000	1000	55.0	38.7	26	21.9
A-45	1000	1000	54.1	38.0	32.5	22.4
A-46	1000	1000	53.3	32.1	27.5	19.3
Average			54.1	36.3	28.7	21.2

Table 9  
Tensile Properties of Potomac M  
(Non-Stressed Stability Specimens)

Spec. No.	Exposure Temp. (°F)	Test Temp. (°F)	U. T. S. ksi	Yield Strengths (ksi) 0.02%	Yield Strengths (ksi) 0.2%	Elong. %	Modulus of Elasticity 10 <sup>6</sup> psi
B-29	600	RT	97.0	70.6	75.2	11.5	32.5
B-30	600	RT	100	65.1	76.6	16	32.9
B-31	600	RT	101	65.2	78.7	12.5	29.5
Average			99.3	67.0	76.8	13.3	31.6
B-32	600	600	85.7	56.2	65.5	12.5	25.9
B-33	600	600	87.5	54.0	65.8	11.5	27.5
B-34	600	600	87.8	53.5	66.6	10.5	21.3
Average			87.0	54.6	66.0	11.5	24.9
B-35	800	RT	97.5	66.7	76.8	13.5	28.8
B-36	800	RT	102	68.5	81.0	12.5	28.1
B-37	800	RT	99.5	70.5	78.4	13	29.5
Average			99.7	68.6	78.7	13	28.8
B-38	800	800	85.4	52.3	61.3	12	20.5
B-39	800	800	85.0	48.3	61.3	12.5	22.3
B-40 (R)	800	800	83.6	51.1	63.2	11.0	21.7
Average			84.7	50.6	61.9	11.8	21.5
B-41	1000	RT	98.5	74.0	77.5	13.5	31.4
B-42	1000	RT	97.0	64.2	75.0	12	29.8
B-43	1000	RT	97.0	64.7	74.7	13.5	34.7
Average			97.5	67.6	75.7	13.0	32.0
B-44	1000	1000	62.3	42.1	52.0	19.5	23.4
B-45	1000	1000	64.9	46.5	54.5	16	20.6
B-46	1000	1000	60.9	38.8	51.0	18.5	21.7
Average			62.7	42.5	52.5	18.0	21.9

Table 10  
Tensile Properties of AM-350  
(Non-Stressed Stability Specimens)

Spec. No.	Exposure Temp. (°F)	Test Temp. (°F)	U, T, S. ksi	Yield Strengths (ksi) 0.02%	Yield Strengths (ksi) 0.2%	Elong. %	Modulus of Elasticity 10 <sup>6</sup> psi
C-29	600	RT	178	49.7	62.5	38.5	24.0
C-30	600	RT	165	48.9	62.4	44.5	23.7
C-31	600	RT	178	51.0	62.8	40	33.5
Average			174	49.9	62.6	41.0	27.1
C-32	600	600	90.9	32.4	40.4	35.5	14.2*
C-33	600	600	91.2	30.2	38.8	37	16.9
C-34	600	600	92.5	27.5	38.8	38.5	25.6
Average			91.5	30.0	39.3	37.0	25.6
C-35	800	RT	177	47.5	62.6	42	36.4
C-36	800	RT	173	49.8	63.5	39.5	31.3
C-37	800	RT	177	52.8	63.8	42.5	28.5
Average			176	50.0	63.3	41.3	32.1
C-38	800	800	91.3	31.0	40.3	36	13.9*
C-39	800	800	92.7	33.6	41.6	34	23.5
C-40	800	800	94.2	33.6	40.7	35	24.6
Average			92.7	32.7	40.9	35.0	24.0
C-41	1000	RT	194	51.1	71.5	16.5	17.4
C-42	1000	RT	183**	54.0	79.7	18	24.5
C-43	1000	RT	193	40.4	70.2	19	30.9
Average			190	48.5	73.8	17.8	24.3
C-44 (R)	1000	1000	81.2	19.9	31.7	25.5	20.7
C-45 (R)	1000	1000	82.8	24.5	35.5	25.0	25.7
C-46	1000	1000	94.5*	40.9*	61.4*	12.5*	21.6
Average			82.0	22.2	33.6	25.2	22.7

\* Data not included in average

\*\* Failed out of gage length

Table 11  
Tensile Properties of Vasco Jet-1000  
(Non-Stressed Stability Specimens)

Spec. No.	Exposure Temp. (°F)	Test Temp. (°F)	U, T, S, ksi	Yield Strengths (ksi) 0.02%	Yield Strengths (ksi) 0.2%	Elong. %	Modulus of Elasticity 10 <sup>6</sup> psi
D-29	600	RT	85.5	47.5	50.3	17	29.8
D-30	600	RT	88.0	40.5	53.1	18	22.8
D-31	600	RT	90.5	45.1	50.4	20	30.4
Average			88.0	44.4	51.3	18.3	27.7
D-32	600	600	74.9	34.3	41.2	13	24.0
D-33	600	600	72.4	35.8	42.8	15.5	25.7
D-34	600	600	75.9	36.3	38.6	18.5	25.6
Average			74.4	35.5	40.9	15.7	25.1
D-35	800	RT	89.4	45.3	52.3	19	25.5
D-36	800	RT	86.0	45.6	49.0	17.5	21.2
D-37	800	RT	87.0	39.7	49.9	18	27.9
Average			87.5	43.5	50.4	18.2	24.9
D-38	800	800	71.4	32.7	40.0	12.5	19.1
D-39	800	800	72.5	34.6	43.4	18	23.7
D-40	800	800	72.2	32.8	41.6	14	21.7
Average			72.0	33.0	41.6	14.8	21.5
D-41	1000	RT	87.5	34.4	48.6	21	25.7
D-42	1000	RT	86.2	38.8	45.5	20.5	27.0
D-43	1000	RT	88.2	(a)	52.1	19	25.9
Average			87.3	36.6	48.7	20.2	26.2
D-44	1000	1000	46.8	24.3	32.4	25	16.0
D-45	1000	1000	48.4	24.6	33.0	26	18.6
D-46	1000	1000	49.7	25.6	37.8	17.5	19.2
Average			48.3	24.8	33.9	22.8	17.9

(a) Yield not obtained because of recorder pen malfunction

Table 12  
Tensile Properties of Potomac A  
(Stressed Stability Specimens)

Spec. No.	Prestraining Conditions		% Elong. During Prestressing	Test Temp. (°F)	U, T. S. Yield Strengths (ksi)		Elong. %	Modulus of Elasticity 10 <sup>6</sup> psi	
	Temp. (°F)	Stress (psi)			ksi	0.02%			0.2%
A47	600	22,000	0	RT	99.5	74.5	80.5	18	32.3
A48	600	22,000	0	RT	98.0	70.0	76.5	19	27.4
A49	600	22,000	0	RT	94.0	72.2	77.5	21	29.1
Average					97.2	72.2	78.2	19.3	29.6
A50	600	22,000	0	600	86.0	61.8	72.1	12.5	29.2
A51	600	22,000	0	600	87.3	65.3	65.8	13.5	31.7
A52	600	22,000	0	600	86.2	59.2	63.4	11.5	28.1
Average					86.5	62.1	67.1	12.5	29.7
A53	800	20,400	0	RT	96.3	80.7	79.3	18	28.1
A54	800	20,400	0	RT	97.5	76.0	76.1	19	30.9
A55	800	20,400	0	RT	97.5	77.2	77.5	20	28.1
Average					97.1	78.0	77.6	19	29.0
A56	800	20,400	0	800	79.8	52.0	60.9	16	23.2
A57	800	20,400	0	800	79.7	48.0	57.2	15	22.0
A58	800	20,400	0	800	81.2	50.3	63.3	16.5	20.8
Average					80.2	50.1	60.5	15.8	22.0
A59	1000	15,500	0	RT	90.3	65.8	68.0	19	25.6
A60	1000	15,500	0.5	RT	96.0	58.0	69.0	23.5	27.7
A61	1000	15,500	0.5	RT	94.3	64.0	68.4	22.5	27.9
Average					93.5	62.6	68.5	21.7	27.1
A62	1000	15,500	0	1000	54.6	37.4	46.7	30	14.2
A63	1000	15,500	1.0	1000	51.0	35.8	43.7	35.5	10.5*
A64	1000	15,500	0.5	1000	52.8	36.5	44.0	32	13.1
Average					52.8	36.6	44.8	32.4	13.6

\* Not used in average.

Table 13  
Tensile Properties of Potomac M  
(Stressed Stability Specimens)

Spec. No.	Prestraining Conditions		% Elong. During Prestressing	Test Temp. (°F)	U. T. S.		Yield Strengths (ksi)	Elong. %	Modulus of Elasticity 10 <sup>6</sup> psi
	Temp. (°F)	Stress (psi)			ksi	0.02%			
B-47	600	21,800	0.5	RT	94.0	62.0	75.0	16	30.5
B-48	600	21,800	0.5	RT	99.4	66.0	77.3	15.5	34.2
B-49	600	21,800	0.5	RT	98.5	62.4	76.0	14.5	32.0
Average					97.3	63.5	76.1	15.3	32.2
B-50	600	21,800	1.0	600	84.5	50.0	65.6	12.5	24.7
B-51	600	21,800	0.5	600	84.5	55.7	64.5	11	38.9*
B-52	600	21,800	1.0	600	84.0	55.8	67.5	10.5	27.8
Average					84.3	53.8	65.9	11.3	26.3
B-53	800	20,500	0	RT	97.5	76.0	77.8	15	28.2
B-54	800	20,500	0	RT	98.5	72.5	76.5	15	27.7
B-55	800	20,500	0	RT	99.0	68.8	78.0	15.5	30.2
Average					98.3	72.4	77.4	15.2	28.7
B-56	800	20,500	0	800	82.5	48.4	61.6	11	21.6
B-57	800	20,500	0.5	800	81.3	49.7	59.4	11.5	23.9
B-58	800	20,500	0	800	81.7	52.0	61.0	11	21.7
Average					81.8	50.0	60.7	11.2	22.4
B-59	1000	16,900	1.0	RT	94.2	65.4	72.4	16.5	34.4
B-60	1000	16,900	0.5	RT	96.0	59.5	73.5	16.5	29.6
B-61	1000	16,900	0	RT	98.0	64.8	78.8	15	35.1
Average					96.1	63.2	74.9	16.0	33.0
B-62	1000	16,900	0	1000	61.6	41.3	51.7	22	17.7
B-63	1000	16,900	0.5	1000	62.8	41.8	54.2	17.5	18.1
B-64	1000	16,900	1.0	1000	60.8	39.6	51.7	18.5	15.6
Average					61.7	40.9	52.5	19.3	17.1

\* Not used in average.

Table 14  
Tensile Properties of AM-350  
(Stressed Stability Specimens)

Spec. No.	Prestraining Conditions		% Elong. During Prestressing	Test Temp. (°F)	U. T. S. ksi	Yield Strengths (ksi)		Elong. %	Modulus of Elasticity 10 <sup>6</sup> psi
	Temp. (°F)	Stress (psi)				0.02%	0.2%		
C-47	600	13,100	0	RT	162	50.7	64.5	42	28.6
C-48	600	13,100	0.5	RT	160	50.0	61.3	43.5	20.6*
C-49	600	13,100	1.0	RT	158	48.6	60.8	45	24.3
Average					160	49.8	62.2	43.5	26.5
C-50	600	13,100	0	600	90.5	30.8	40.3	36.5	25.9
C-51	600	13,100	0	600	91.7	31.4	41.4	37	16.1*
C-52	600	13,100	0	600	92.0	29.6	39.7	37.5	25.3
Average					91.4	30.6	40.5	37	25.6
C-53	800	11,950	0	RT	163	46.5	59.8	44	31.2
C-54	800	11,950	0.5	RT	164	48.3	62.3	47	29.2
C-55	800	11,950	0	RT	163	48.3	62.8	46.5	29.0
Average					163	47.7	61.6	45.8	29.8
C-56	800	11,950	0	800	90.0	33.9	40.3	36.5	25.0
C-57	800	11,950	0	800	91.0	34.8	42.3	36.5	25.0
C-58	800	11,950	0	800	90.9	24.3	37.8	37	20.9
Average					90.6	31.0	40.1	36.7	23.6
C-59	1000	10,850	0	RT	171	51.7	60.5	34	-
C-60	1000	10,850	0	RT	183	31.9	45.7	18	20.9
C-61	1000	10,850	1.0	RT	182	36.9	49.3	17	21.8
Average					179	40.2	51.8	19.7	21.4
C-62	1000	10,850	0	1000	81.2	21.4	30.7	27	28.0
C-63	1000	10,850	0	1000	81.8	24.8	34.4	28.5	23.0
C-64	1000	10,850	0	1000	83.5	21.5	31.4	27.5	26.0
Average					82.2	22.6	32.2	27.7	25.7

\* Data not included in average

Table 15  
Tensile Properties of Vasco Jet-1000  
(Stressed Stability Specimens)

Spec. No.	Prestraining Conditions		% Elong. During Prestressing	Test Temp. (°F)	U <sub>T</sub> , S <sub>T</sub> , ksi	Yield Strengths (ksi)		Elong. %	Modulus of Elasticity 10 <sup>6</sup> psi
	Temp. (°F)	Stress (psi)				0.02%	0.2%		
D-47	600	14,300	0	RT	90.3	42.8	52.6	18.5	18.6*
D-48	600	14,300	0.5	RT	87.4	39.1	53.5	18.5	28.7
D-49	600	14,300	1.0	RT	92.0	44.5	53.8	17	32.2
Average					89.9	42.1	53.4	18	30.4
D-50	600	14,300	1.0	600	73.0	32.3	41.5	14	21.4
D-51	600	14,300	0.5	600	75.4	35.7	45.2	16.5	23.0
D-52	600	14,300	0	600	74.0	37.0	43.3	13.5	23.2
Average					74.1	35.0	43.3	14.7	22.5
D-53	800	13,500	0	RT	86.6	50.7	52.5	21.5	28.8
D-54	800	13,500	0	RT	86.5	51.2	52.9	19.5	26.0
D-55	800	13,500	0	RT	88.3	51.3	53.9	21	30.9
Average					87.1	51.1	53.1	20.7	28.6
D-56 (R)	800	13,500	0.5	800	64.6	28.6	36.9	13.0	9.2*
D-57	800	13,500	0	800	68.7	33.9	41.3	14.5	20.6
D-58	800	13,500	0	800	70.5	29.5	38.4	13.5	19.2
Average					67.9	30.7	38.9	13.7	19.9
D-59	1000	10,750	1.5	RT	88.0	48.2	51.4	20.5	30.2
D-60	1000	10,750	0	RT	89.0	44.6	47.7	22.5	23.9*
D-61	1000	10,750	0.5	RT	93.0	(a)	-	17	26.5
Average					90.0	46.4	49.8	20.0	28.4
D-62 (R)	1000	10,750	0.5	1000	44.8	17.3	25.9	23.5	10.3
D-63	1000	10,750	1.0	1000	45.6	24.1	29.4	31.5	15.3
D-64	1000	10,750	0	1000	49.2	28.1	35.2	25	12.0
Average					46.5	23.2	30.4	26.6	12.5

\* Data not included in average

(a) Yield not obtained because of recorder malfunction

Table 16  
Sheet Shear Properties of Potomac A

Specimen No.	Temperature (°F)	Ult. Shear Strength (ksi)
A-65	RT	79.4
A-66	RT	81.3
A-67	RT	81.2
A-68	RT	80.4
A-69	RT	79.5
A-70	RT	80.8
A-71	RT	84.2
A-72	RT	81.0
A-73	RT	80.4
A-74	RT	81.6
<b>Average</b>		<b>81.0</b>
A-75	400	71.4
A-76	400	69.3
A-77	400	67.7
<b>Average</b>		<b>69.5</b>
A-78	600	63.7
A-79	600	65.2
A-80	600	65.8
<b>Average</b>		<b>65.0</b>
A-81	800	61.3
A-82	800	63.2
A-83	800	60.6
<b>Average</b>		<b>61.7</b>
A-84	1000	49.0
A-85	1000	45.8
A-86	1000	49.3
<b>Average</b>		<b>48.0</b>
A-87	1200	24.5
A-88	1200	28.1
A-89	1200	26.9
<b>Average</b>		<b>26.5</b>

Table 17  
 Sheet Shear Properties of Potomac M

Specimen No.	Temperature (°F)	Ult. Shear Strength (ksi)
B-65	RT	91.3
B-66	RT	90.7
B-67	RT	89.7
B-68	RT	87.2
B-69	RT	88.7
B-70	RT	91.3
B-71	RT	91.4
B-72	RT	88.9
B-73	RT	92.3
B-74	RT	89.8
Average		90.1
B-75	400	75.0
B-76	400	76.3
B-77	400	76.7
Average		76.0
B-78	600	73.9
B-79	600	72.2
B-80	600	75.7
Average		73.9
B-81	800	69.2
B-82	800	68.1
B-83	800	71.5
Average		69.6
B-84	1000	58.8
B-85	1000	57.4
B-86	1000	58.0
Average		58.1
B-87	1200	32.3
B-88	1200	31.5
B-89	1200	31.8
Average		31.9

Table 18  
Sheet Shear Properties of AM-350

Specimen No.	Temperature (°F)	Ult. Shear Strength (ksi)
C-65	RT	149
C-66	RT	145
C-67	RT	149
C-68	RT	151
C-69	RT	149
C-70	RT	146
C-71	RT	151
C-72	RT	147
C-73	RT	147
C-74	RT	145
Average		148
C-75	400	78.1
C-76	400	80.2
C-77	400	77.2
Average		78.5
C-78	600	70.3
C-79	600	72.2
C-80	600	72.2
Average		71.6
C-81	800	68.3
C-82	800	68.2
C-83	800	69.8
Average		68.8
C-84	1000	61.3
C-85	1000	62.2
C-86	1000	62.7
Average		62.1
C-87	1200	50.8
C-88	1200	53.1
C-89	1200	51.2
Average		51.7

Table 19  
Sheet Shear Properties of Vasco Jet-1000

Specimen No.	Temperature (° F)	Ult. Shear Strength (ksi)
D-65	RT	77.0
D-66	RT	76.6
D-67	RT	77.2
D-68	RT	78.3
D-69	RT	77.6
D-70	RT	74.8
D-71	RT	75.7
D-72	RT	79.9
D-73	RT	78.7
D-74	RT	77.8
Average		77.4
D-75	400	64.2
D-76	400	63.7
D-77	400	65.8
Average		64.6
D-78	600	60.2
D-79	600	61.6
D-80	600	61.2
Average		61.0
D-81	800	54.8
D-82	800	55.2
D-83	800	56.3
Average		55.4
D-84	1000	43.3
D-85	1000	44.7
D-86	1000	42.7
Average		43.6
D-87	1200	24.5
D-88	1200	25.7
D-89	1200	31.1
Average		27.1

Table 20  
Compressive Properties of Potomac A

Specimen No.	Temperature (°F)	0.2% Yield ksi	.7 Secant ksi	.85 Secant ksi	Modulus of Elasticity 10 <sup>6</sup> psi
A-90	RT	51.5	34.5	25.3	27.7
A-91	RT	54.6	44.3	39.9	28.9
A-92	RT	54.9	43.7	32.9	26.4
A-93	RT	47.5	29.0	23.1	29.1
A-94	RT	55.9	42.8	32.9	27.4
A-95	RT	54.8	40.3	32.1	30.0
A-96	RT	67.4	58.3	42.6	30.3
A-97	RT	64.4	45.5	33.3	30.0
A-98	RT	61.8	44.8	32.2	26.8
A-99	RT	59.1	34.5	31.1	38.9*
Average		57.2	41.8	32.5	29.6
A-100	400	45.2	32.7	28.9	29.4
A-101	400	43.4	27.0	20.9	26.8
A-102	400	57.7	49.5	37.6	25.8
Average		48.8	36.4	29.1	27.3
A-103	600	46.0	33.4	27.4	28.9
A-104	600	50.3	37.1	30.0	56.6*
A-105	600	55.8	39.6	31.1	32.8
Average		50.7	36.7	29.5	30.9
A-106	800	45.0	33.8	29.4	32.7*
A-107(R)	800	48.5	41.5	38.6	28.2
A-108(R)	800	51.2	43.7	41.1	26.3
Average		48.2	39.7	36.4	27.2
A-109	1000	47.6	42.7	38.0	22.3
A-110	1000	47.0	39.1	33.0	24.6
A-111	1000	47.3	39.6	32.0	26.7
Average		47.3	40.5	34.3	24.5
A-112	1200	23.0	22.8	20.8	9.4
A-113	1200	25.7	22.7	18.4	12.2
A-114	1200	28.4	27.8	26.2	9.3
Average		25.7	24.4	21.8	10.3

\* Not used in average.

Table 21  
Compressive Properties of Potomac M

Specimen No.	Temperature (°F)	0.2% Yield (ksi)	.7 Secant (ksi)	.85 Secant (ksi)	Modulus of Elasticity 10 <sup>6</sup> psi
B90	RT	75.0	69.5	61.8	28.8
B91	RT	76.8	69.5	62.5	31.8
B92	RT	71.1	64.2	56.1	28.5
B93	RT	73.0	65.5	54.5	29.4
B94	RT	77.0	71.5	61.8	26.7
B95	RT	75.8	71.3	61.3	29.2
B96	RT	76.3	66.3	58.3	44.9*
B97	RT	77.8	72.7	67.3	30.3
B98	RT	77.5	71.3	64.8	33.8
B99	RT	80.5	74.9	66.3	30.2
Average		76.1	69.7	61.5	29.9
B100	400	73.3	67.7	61.2	28.4
B101	400	72.0	66.8	61.3	26.9
B102	400	65.2	59.2	48.8	27.2
Average		70.2	64.6	57.1	27.5
B103	600	67.5	65.8	58.3	24.3
B104	600	68.3	63.8	58.3	26.9
B105	600	67.2	64.2	59.2	24.7
Average		67.7	64.6	58.6	25.3
B106	800	57.0	51.8	45.5	25.4
B107	800	68.7	64.0	54.3	26.0
B108	800	65.8	60.8	55.0	25.9
Average		63.8	58.9	51.6	25.8
B109	1000	61.8	54.6	47.5	23.8
B110	1000	53.3	48.5	44.3	24.0
B111	1000	60.3	57.6	52.2	23.1
Average		58.5	53.6	48.0	23.6
B112	1200	25.8	23.3	19.3	10.7
B113	1200	22.5	20.8	19.5	9.0
B114	1200	29.5	27.5	25.3	11.5
Average		25.9	23.9	21.4	10.4

\* Not used in average.

Table 22  
Compressive Properties of AM-350

Specimen No.	Temperature (°F)	0.2% Yield ksi	.7 Secant ksi	.85 Secant ksi	Modulus of Elasticity 10 <sup>6</sup> psi
C-90	RT	64.0	61.2	54.7	23.4
C-91	RT	63.5	58.8	52.5	27.5
C-92	RT	63.6	58.3	51.7	26.6
C-93	RT	63.2	55.7	48.6	30.6
C-94	RT	64.7	58.5	51.7	30.1
C-95	RT	63.3	58.9	53.3	24.9
C-96	RT	63.8	58.8	51.9	28.9
C-97	RT	66.3	61.3	56.3	31.1
C-98	RT	64.3	60.0	55.3	26.0
C-99	RT	63.8	57.1	50.2	31.3
Average		63.0	58.9	52.6	28.0
C-100	400	44.2	38.2	32.2	29.3
C-101	400	41.9	37.5	33.0	24.2
C-102	400	45.0	40.1	35.1	26.3
Average		43.7	38.6	33.4	26.6
C-103	600	40.4	32.5	27.3	27.1
C-104	600	39.7	35.9	32.5	19.4*
C-105	600	42.0	36.0	31.9	27.9
Average		40.7	34.8	30.6	27.5
C-106	800	46.2	40.3	34.8	23.9
C-107	800	39.2	34.8	31.4	20.8
C-108	800	37.3	35.2	29.7	17.7
Average		40.9	36.8	32.0	20.8
C-109	1000	34.8	28.5	23.8	22.5
C-110	1000	35.7	29.5	25.2	24.4
C-111	1000	34.1	26.2	22.0	29.8*
Average		34.9	28.1	23.7	23.5
C-112	1200	31.9	28.2	26.3	26.3
C-113	1200	27.4	20.6	16.4	28.3*
C-114	1200	25.3	20.8	16.6	22.1
Average		28.2	23.2	19.8	24.2

\* Not used in average

Table 23  
Compressive Properties of Vasco Jet-1000

Specimen No.	Temperature (°F)	0.2% Yield ksi	.7 Secant ksi	.85 Secant ksi	Modulus of Elasticity 10 <sup>6</sup> psi
D-90	RT	48.4	44.6	41.7	31.3
D-91	RT	49.2	43.6	38.3	26.6
D-92	RT	41.5*	32.9*	25.5*	29.8
D-93	RT	49.3	43.7	37.9	29.5
D-94	RT	52.2	46.7	39.9	29.8
D-95	RT	57.7	52.2	46.7	34.9***
D-96	RT	61.2	53.4	41.8	30.9
D-97	RT	62.6	56.7	44.5	30.2
D-98	RT	58.1	52.7	46.4	35.8***
D-99	RT	58.7	54.7	49.3	30.9***
Average		55.0	48.6	43.0	29.9
D-100	400	33.7	29.8	26.6	27.8
D-101	400	35.6	29.2	23.8	29.7***
D-102	400	49.4*	44.6*	38.9*	30.0
Average		34.6	29.5	25.2	29.2
D-103	600	36.8	32.1	27.1	24.4
D-104	600	**	**	**	**
D-105	600	37.7	31.7	30.3	28.5
Average		37.3	31.9	28.7	26.4
D-106	800	32.3	25.3	22.1	28.7
D-107	800	28.3	21.9	18.8	24.7
D-108	800	34.0	28.5	26.4	24.7***
Average		31.5	25.2	22.5	26.0
D-109	1000	30.4	23.4	21.9	35.7*
D-110	1000	29.9	23.8	20.4	24.0
D-111	1000	28.2	22.6	20.1	20.5***
Average		29.5	23.3	20.8	22.3
D-112	1200	24.1	22.1	20.8	15.2
D-113	1200	27.5	26.3	24.8	13.5
D-114	1200	22.5	19.2	17.7	17.5***
Average		24.7	22.5	21.1	15.4

\* Not used in average

\*\*\* Faces ground smooth

\*\* Recorder malfunction

CODE FOR SYMBOLS AND TERMS USED IN TABLES 24-31

Bearing Tests

Failure

Location - as shown in sketches the specimen failed in one of three ways:

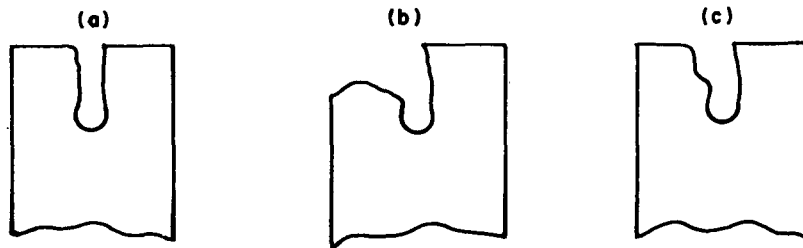

Compression Tests

0.7 Secant

That stress which gives a secant modulus equal to 0.7 of the elastic modulus

0.85 Secant

That stress which gives a secant modulus equal to 0.85 of the elastic modulus

Table 24  
Bearing Properties of Potomac A  
 $e/D = 1.5$

Specimen No.	Temperature (°F)	Failure Location	Bearing Ultimate Strength (ksi)	Bearing Yield Strength (ksi)
A-115	RT	(a)	162	129
A-116	RT	(a)	157	120
A-117	RT	(a)	155	118
A-118	RT	(a)	159	127
A-119	RT	(a)	155	124
A-120	RT	(a)	155	122
A-121	RT	(c)	155	113*
A-122	RT	(a)	161	132
A-123	RT	(a)	160	129
A-124	RT	(c)	162	130
Average			158	126
A-125	400	(a)	146	121
A-126	400	(a)	147	115
A-127	400	(c)	145	113
Average			146	116
A-128 (R)	600	(a)	145	118
A-129 (R)	600	(a)	145	110
A-130	600	(a)	141	118
Average			144	115
A-131	800	(a)	133	112
A-132	800	(a)	132	110
A-133	800	(a)	132	114
Average			132	112
A-134 (R)	1000	(a)	164	86.5
A-135 (R)	1000	(a)	162	86.6
A-136	1000	(a)	109	92.3
Average			105	88.3
A-137	1200	(a)	63.3	53.2
A-138	1200	(a)	60.9	52.7
A-139	1200	(a)	64.3	50.1
Average			62.8	52.0

\* Not used in average

Table 25  
Bearing Properties of Potomac M  
 $e/D = 1.5$

<u>Specimen No.</u>	<u>Temperature (°F)</u>	<u>Failure Location</u>	<u>Bearing Ultimate Strength (ksi)</u>	<u>Bearing Yield Strength (ksi)</u>
B-115	RT	(a)	165	129
B-116	RT	(c)	166	131
B-117	RT	(c)	163	129
B-118	RT	(a)	160	127
B-119	RT	(a)	163	129
B-120	RT	(c)	162	131
B-121	RT	(a)	164	130
B-122	RT	(a)	163	135
B-123	RT	(c)	167	137
B-124	RT	(c)	167	135
Average			164	131
B-125 (R)	400	(a)	155	132*
B-126	400	(a)	157	123
B-127	400	(a)	160	129
Average			157	128
B-128	600	(a)	160	126
B-129	600	(a)	157	125
B-130	600	(a)	159	-
Average			159	125
B-131	800	(a)	148	136*
B-132	800	(a)	146	124
B-133	800	(a)	152	123
Average			149	124
B-134	1000	(a)	117	98.1
B-135	1000	(a)	119	101
B-136	1000	(a)	126	107
Average			121	102
B-137	1200	(a)	70.8	52.7
B-138	1200	(a)	65.8	56.7
B-139	1200	(a)	70.3	51.3
Average			69.0	53.6

Table 26  
 Bearing Properties of AM-350  
 $e/D = 1.5$

<u>Specimen No.</u>	<u>Temperature (°F)</u>	<u>Failure Location</u>	<u>Bearing Ultimate Strength (ksi)</u>	<u>Bearing Yield Strength (ksi)</u>
C-115	RT	(a)	252	102
C-116	RT	(a)	267	111
C-117	RT	(a)	261	110
C-118	RT	(a)	249	111
C-119	RT	(a)	262	109
C-120	RT	(a)	266	108
C-121	RT	(a)	271	-
C-122	RT	(a)	273	108
C-123	RT	(a)	272	111
C-124	RT	(a)	270	108
<u>Average</u>			<u>264</u>	<u>109</u>
C-125	400	(a)	156	81.8
C-126	400	(a)	156	79.3
C-127	400	(a)	156	83.8
<u>Average</u>			<u>156</u>	<u>81.6</u>
C-128	600	(a)	149	83.8
C-129	600	(a)	147	81.4
C-130	600	(a)	149	79.2
<u>Average</u>			<u>148</u>	<u>81.5</u>
C-131	800	(a)	146	78.7
C-132	800	(a)	154	82.8
C-133	800	(a)	145	81.3
<u>Average</u>			<u>148</u>	<u>80.9</u>
C-134	1000	(a)	135	72.7
C-135	1000	(a)	133	-
C-136	1000	(a)	134	76.7
<u>Average</u>			<u>134</u>	<u>74.7</u>
C-137 (R)	1200	(a)	104	-
C-138	1200	(a)	107	64.2
C-139	1200	(a)	112	67.6
<u>Average</u>			<u>107</u>	<u>65.9</u>

Table 27  
 Bearing Properties of Vasco Jet-1000  
 $e/D = 1.5$

Specimen No.	Temperature (°F)	Failure Location	Bearing Ultimate Strength (ksi)	Bearing Yield Strength (ksi)
D-115	RT	(c)	151	113
D-116	RT	(a)	145	98.3
D-117	RT	(a)	143	100
D-118	RT	(a)	139	-
D-119	RT	(a)	144	103
D-120	RT	(c)	145	96.5
D-121	RT	(a)	148	102
D-122	RT	(c)	150	103
D-123	RT	(a)	153	113
D-124	RT	(a)	155	113
Average			147	105
D-125	400	(c)	129	94.7
D-126	400	(a)	130	93.2
D-127	400	(a)	137	102
Average			132	96.6
D-128 (R)	600	(a)	121	-
D-129	600	(a)	135	107
D-130	600	(a)	126	107
Average			128	107
D-131	800	(a)	114	89.2
D-132	800	(a)	114	92.7
D-133 (R)	800	(a)	112	-
Average			113	90.9
D-134	1000	(a)	88.7	70.2
D-135	1000	(a)	89.6	68.6
D-136 (R)	1000	(a)	82.0	-
Average			86.8	69.4
D-137 (R)	1200	(a)	57.8	-
D-138	1200	(a)	61.4	46.1
D-139	1200	(a)	68.2	51.8
Average			62.5	49.0

- Data not obtained

Table 28  
Bearing Properties of Potomac A  
e/D = 2.0

Specimen No.	Temperature (°F)	Failure Location	Bearing Ultimate Strength (ksi)	Bearing Yield Strength (ksi)
A-140	RT	(a)	202	140
A-141	RT	(a)	203	144
A-142	RT	(a)	199	140
A-143	RT	(a)	202	142
A-144	RT	(a)	202	141
A-145	RT	(a)	200	138
A-146	RT	(c)	200	139
A-147	RT	(a)	201	136
A-148	RT	(c)	202	145
A-149	RT	(a)	203	145
Average			201	141
A-150	400	(a)	188	134
A-151	400	(b)	181	128
A-152	400	(a)	184	128
Average			184	130
A-153	600	(a)	185	135
A-154	600	(a)	185	133
A-155	600	(b)	185	133
Average			185	134
A-156	800	(a)	178	133
A-157	800	(b)	173	131
A-158	800	(a)	172	132
Average			174	132
A-159	1000	(a)	133	103
A-160	1000	(a)	134	104
A-161	1000	(a)	133	102
Average			133	103
A-162	1200	(a)	72.6	53.6
A-163	1200	(a)	77.6	54.8
A-164	1200	(a)	69.9	53.8
Average			73.4	54.1

Table 29  
Bearing Properties of Potomac M  
e/D = 2.0

Specimen No.	Temperature (°F)	Failure Location	Bearing Ultimate Strength (ksi)	Bearing Yield Strength (ksi)
B-140	RT	(b)	220	161
B-141	RT	(b)	222	163
B-142	RT	(b)	218	-
B-143	RT	(b)	213	157
B-144	RT	(b)	223	166
B-145	RT	(a)	225	-
B-146	RT	(c)	226	159
B-147	RT	(a)	227	161
B-148	RT	(a)	217	164
B-149	RT	(b)	223	149
Average			221	160
B-150	400	(a)	204	144
B-151	400	(b)	198	138
B-152	400	(b)	207	149
Average			203	144
B-153	600	(b)	196	154
B-154	600	(b)	192	144
B-155 (R)	600	(a)	200	158
Average			196	152
B-156	800	(a)	196	149
B-157	800	(a)	193	153
B-158	800	(a)	193	153
Average			194	152
B-159 (R)	1000	(a)	157	119
B-160 (R)	1000	(a)	198	125
B-161 (R)	1000	(a)	193	114
Average			156	119
B-162	1200	(a)	89.5	63.7
B-163	1200	(a)	94.2	66.4
B-164	1200	(a)	94.7	62.3
Average			92.8	64.1

Table 30  
Bearing Properties of AM-350  
e/D = 2.0

Specimen No.	Temperature (°F)	Failure Location	Bearing Ultimate Strength (ksi)	Bearing Yield Strength (ksi)
C-140	RT	(a)	339	125
C-141	RT	(a)	386*	135
C-142	RT	(a)	355	135
C-143	RT	(b)	354	138
C-144	RT	(c)	359	139
C-145	RT	(a)	355	134
C-146	RT	(a)	352	134
C-147	RT	(a)	348	132
C-148	RT	(b)	349	134
C-149	RT	(c)	341	132
Average			350	134
C-150	400	(a)	221	171*
C-151 (R)	400	(b)	197	174
C-152 (R)	400	(c)	197	168
Average			205	171
C-153	600	(a)	208	100
C-154	600	(a)	195	98.2
C-155	600	(a)	196	92.8
Average			200	97.0
C-156	800	(b)	194	98.0
C-157	800	(a)	188	93.6
C-158	800	(a)	191	90.8
Average			191	94.1
C-159	1000	(a)	186	-
C-160	1000	(a)	178	89.7
C-161	1000	(a)	179	87.2
Average			181	88.5
C-162	1200	(a)	126	68.8
C-163	1200	(a)	133	60.7
C-164	1200	(a)	135	-
Average			131	64.8

\* Not used in average

\*\* Data not obtained.

Table 31  
 Bearing Properties of Vasco Jet-1000  
 $e/D = 2.0$

Specimen No.	Temperature (°F)	Failure Location	Bearing Ultimate Strength (ksi)	Bearing Yield Strength (ksi)
D-140	RT	(a)	192	117
D-141	RT	(a)	211	136
D-142	RT	(a)	213	137
D-143	RT	(c)	213	131
D-144	RT	(b)	215	134
D-145	RT	(c)	209	128
D-146	RT	(b)	219	147
D-147	RT	(a)	192	120
D-148	RT	(a)	187	115
D-149	RT	(a)	197	134
Average			205	130
D-150	400	(a)	164	97.0
D-151	400	(b)	161	108
D-152 (R)	400	(a)	175	115
Average			167	107
D-153	600	(a)	153	107
D-154	600	(c)	169	130
D-155 (R)	600	(b)	164	110
Average			162	116
D-156	800	(a)	154	105
D-157	800	(a)	169	107
D-158 (R)	800	(a)	150	-
Average			158	106
D-159	1000	(a)	126	91.2
D-160	1000	(a)	111	79.2
D-161	1000	(a)	124	94.0
Average			120	88.1
D-162	1200	(a)	75.6	57.0
D-163	1200	(a)	83.2	59.3
D-164 (R)	1200	(a)	64.3	-
Average			74.4	58.2

Table 31  
 Bearing Properties of Vasco Jet-1000  
 $e/D = 2.0$

Specimen No.	Temperature (°F)	Failure Location	Bearing Ultimate Strength (ksi)	Bearing Yield Strength (ksi)
D-140	RT	(a)	192	117
D-141	RT	(a)	211	136
D-142	RT	(a)	213	137
D-143	RT	(c)	213	131
D-144	RT	(b)	215	134
D-145	RT	(c)	209	128
D-146	RT	(b)	219	147
D-147	RT	(a)	192	120
D-148	RT	(a)	187	115
D-149	RT	(a)	197	134
Average			205	130
D-150	400	(a)	164	97.0
D-151	400	(b)	161	108
D-152 (R)	400	(a)	175	115
Average			167	107
D-153	600	(a)	153	107
D-154	600	(c)	169	130
D-155 (R)	600	(b)	164	110
Average			162	116
D-156	800	(a)	154	105
D-157	800	(a)	169	107
D-158 (R)	800	(a)	150	-
Average			158	106
D-159	1000	(a)	126	91.2
D-160	1000	(a)	111	79.2
D-161	1000	(a)	124	94.0
Average			120	88.1
D-162	1200	(a)	75.6	57.0
D-163	1200	(a)	83.2	59.3
D-164 (R)	1200	(a)	64.3	-
Average			74.4	58.2

**Table 32**  
**Bend Tests of Sheet Material**  
**Minimum Bend Diameter Over 105-Degree Angle**

<u>(Test Temperature: RT)</u>		<u>(Test Temperature: 400°F)</u>	
<u>Material</u>	<u>Longitudinal</u>	<u>Material</u>	<u>Longitudinal</u>
Potomac A	.5 T	Potomac A	.5 T
Potomac M	.5 T	Potomac M	.5 T
AM-350	.5 T	AM-350	.5 T
Vasco Jet-1000	.75 T	Vasco Jet-1000	.75 T

<u>(Test Temperature: 600°F)</u>		<u>(Test Temperature: 800°F)</u>	
<u>Material</u>	<u>Longitudinal</u>	<u>Material</u>	<u>Longitudinal</u>
Potomac A	.5 T	Potomac A	.5 T
Potomac M	.5 T	Potomac M	.5 T
AM-350	.5 T	AM-350	.5 T
Vasco Jet-1000	.75 T	Vasco Jet-1000	.75 T

<u>(Test Temperature: 1000°F)</u>		<u>(Test Temperature: 1200°F)</u>	
<u>Material</u>	<u>Longitudinal</u>	<u>Material</u>	<u>Longitudinal</u>
Potomac A	.5 T	Potomac A	.5 T
Potomac M	.5 T	Potomac M	.5 T
AM-350	.5 T	AM-350	.5 T
Vasco Jet-1000	.75 T	Vasco Jet-1000	.75 T

T = Thickness of Sheet

For Potomac A, Potomac M, AM-350, nominal .063 inch thick

For Vasco Jet-1000, nominal .042 inch thick

Longitudinal specimens

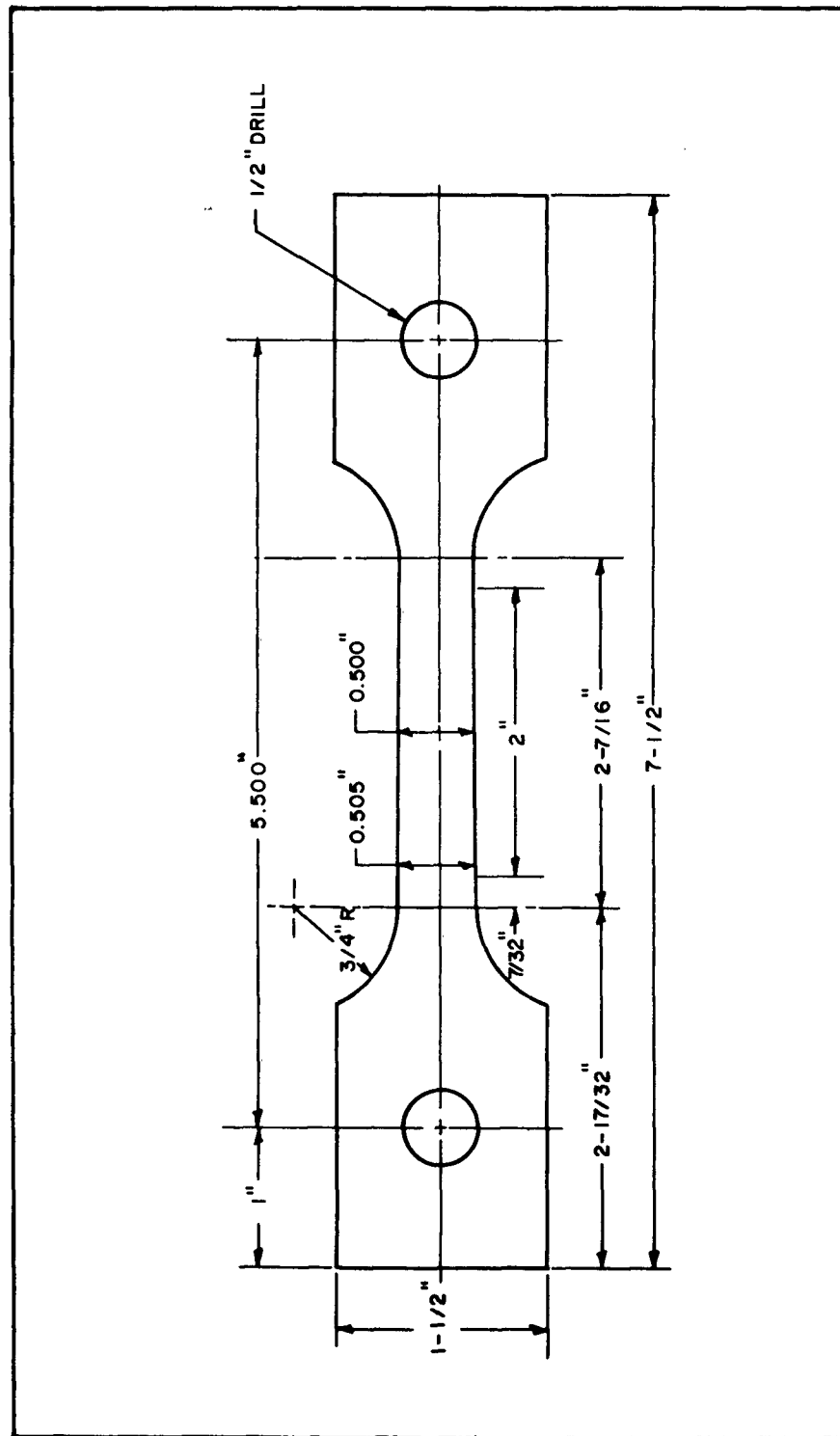

Figure 1. Tensile Specimen

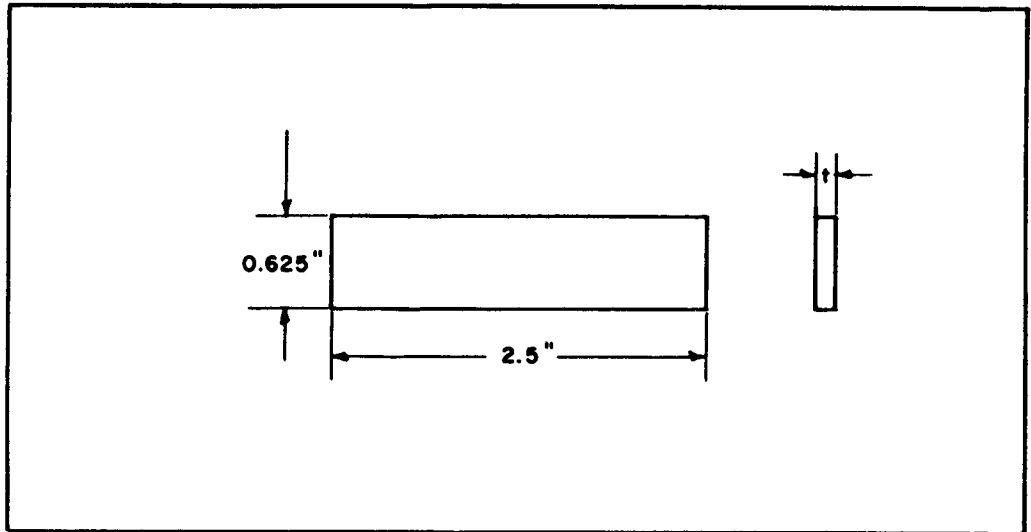

Figure 2. Compression Specimen

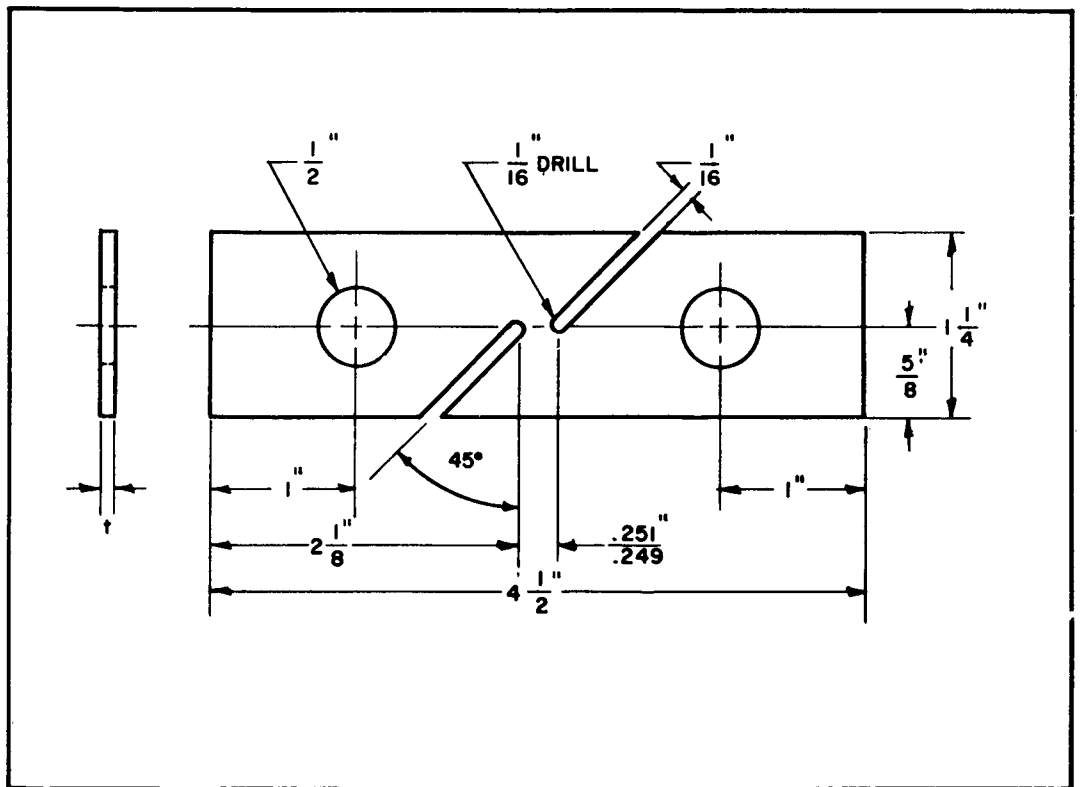

Figure 3. Sheet Shear Specimen

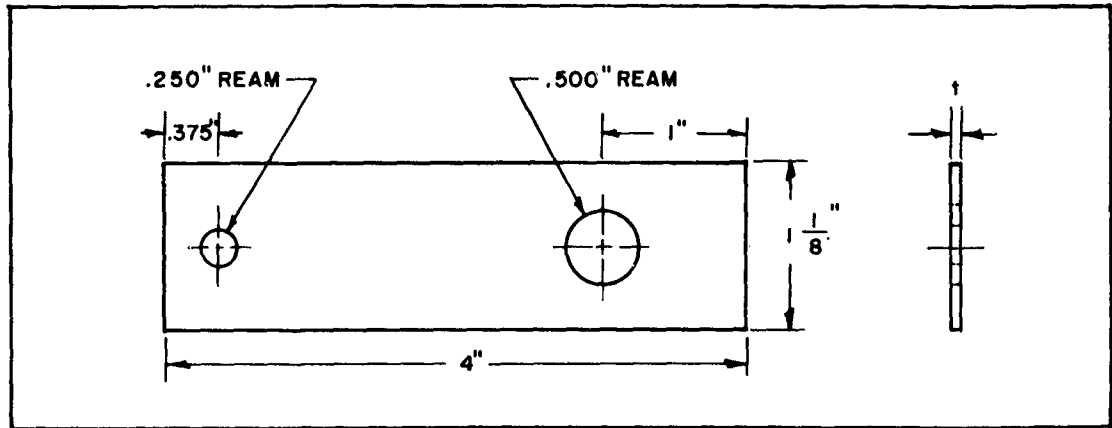

Figure 4. Sheet Bearing Test, Specimen-Bearing Ratio  $e/D = 1.5$

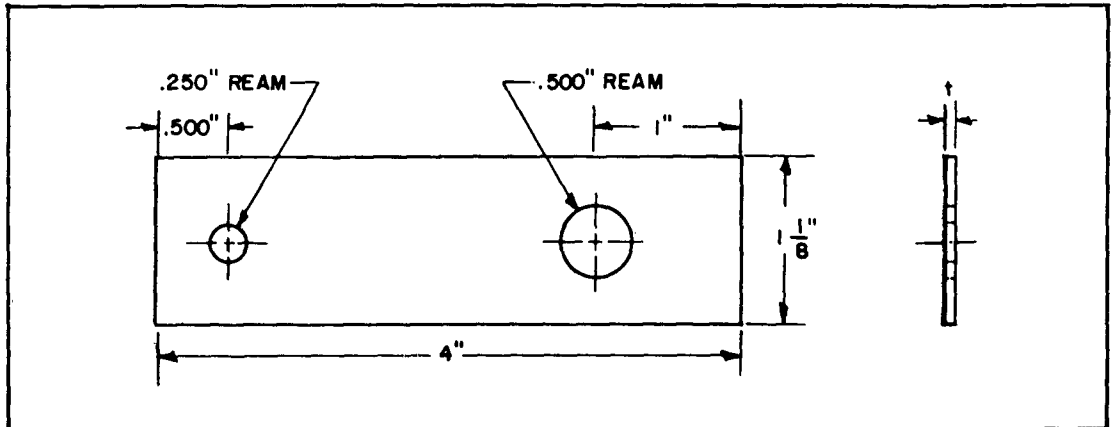

Figure 5. Sheet Bearing Test, Specimen-Bearing Ratio  $e/D = 2.0$

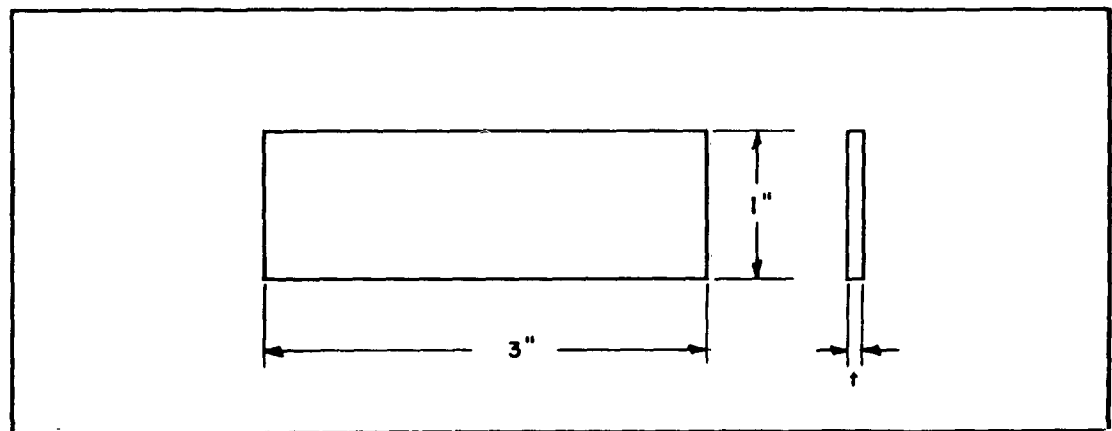

Figure 6. Sheet 105-Degree-Angle Bend Test Specimen

<u>TYPE OF SPECIMEN</u>	<u>ROOM TEMPERATURE</u>	<u>ELEVATED TEMPERATURE</u>
TENSILE	A 1	B 1
SHEAR	A 2	B 2
COMPRESSION	A 3	B 3
BEARING, e/D = 1.5	A 4	B 4
BEARING, e/D = 2.0	A 5	B 5
STRESSED STABILITY	A 6	B 6
BEND	A 7	B 7
NON-STRESSED STABILITY	A 8	B 8
EXTRA BLANKS	X	X

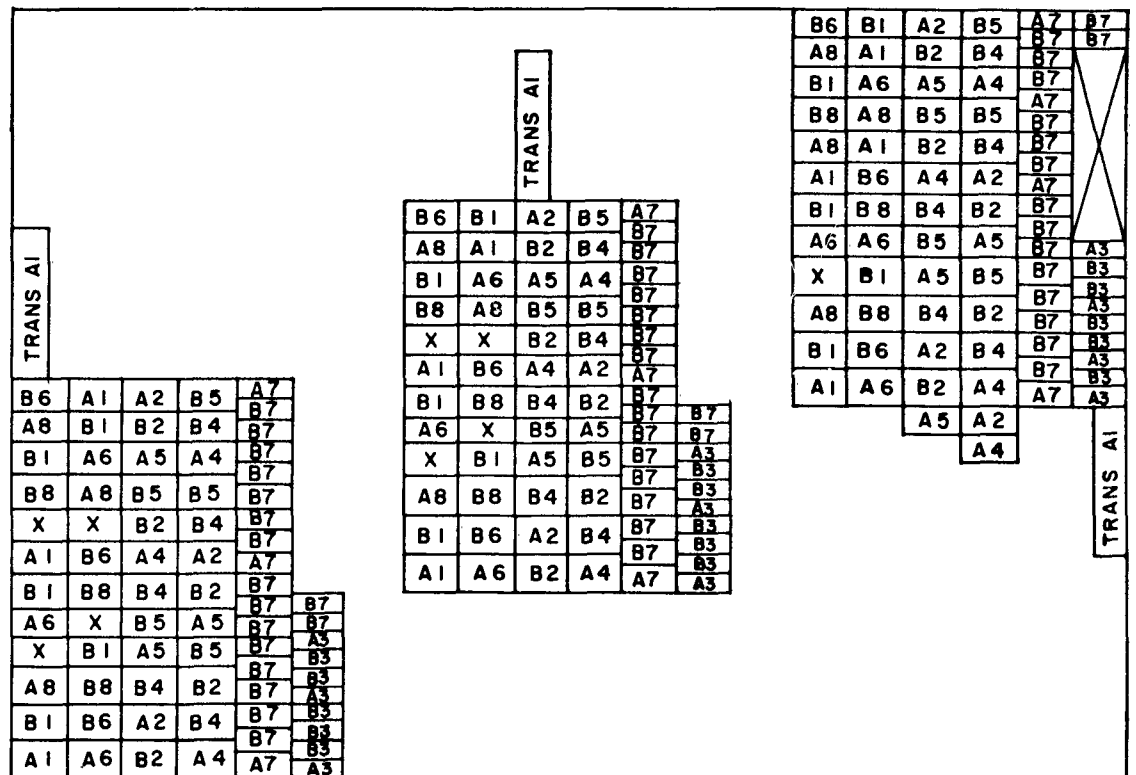

Figure 7. Specimen Layout Key for Sheets of Potomac A, Potomac M, and Vasco Jet-1000



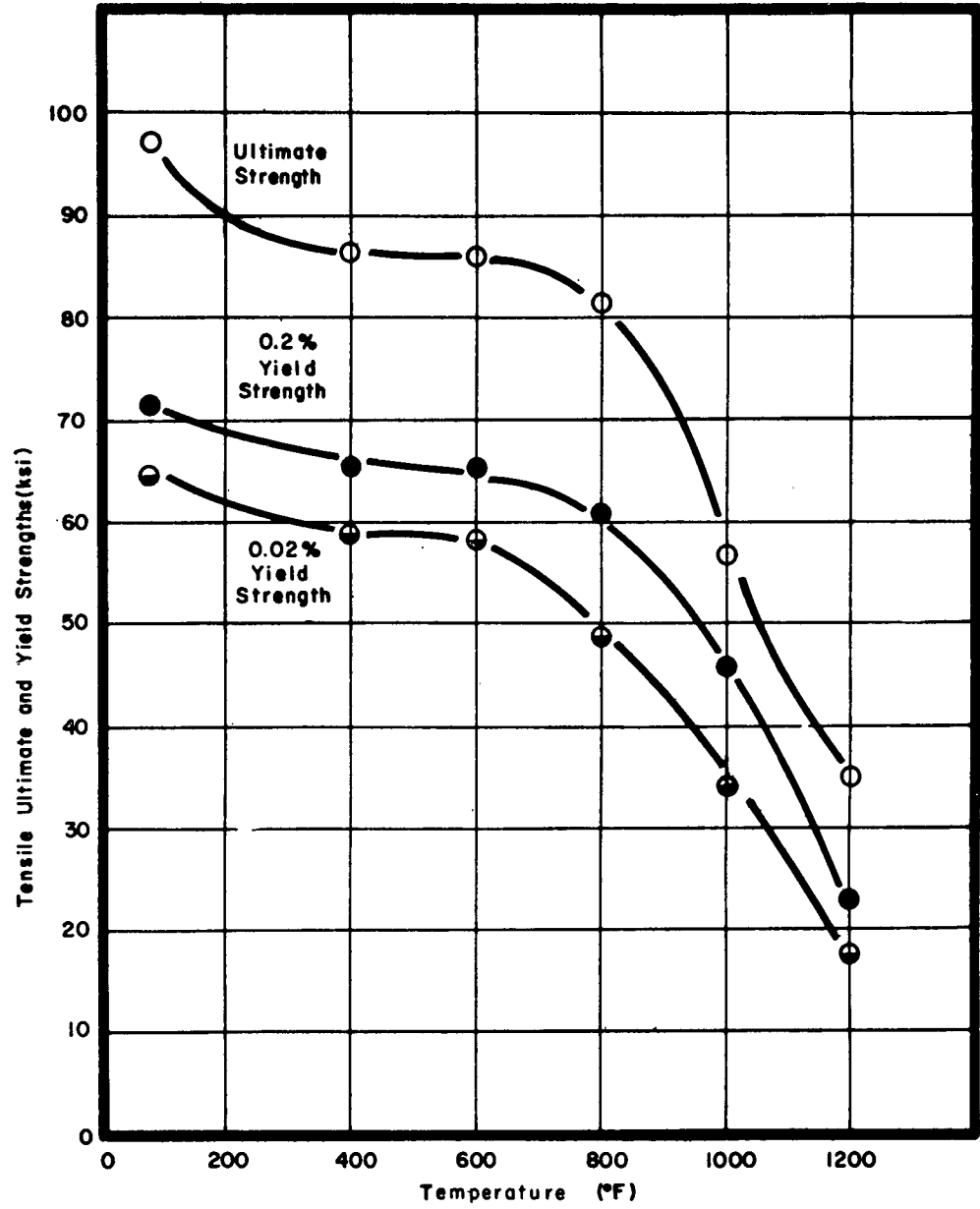

Figure 9. Effect of Temperature on Tensile Properties of Potomac A

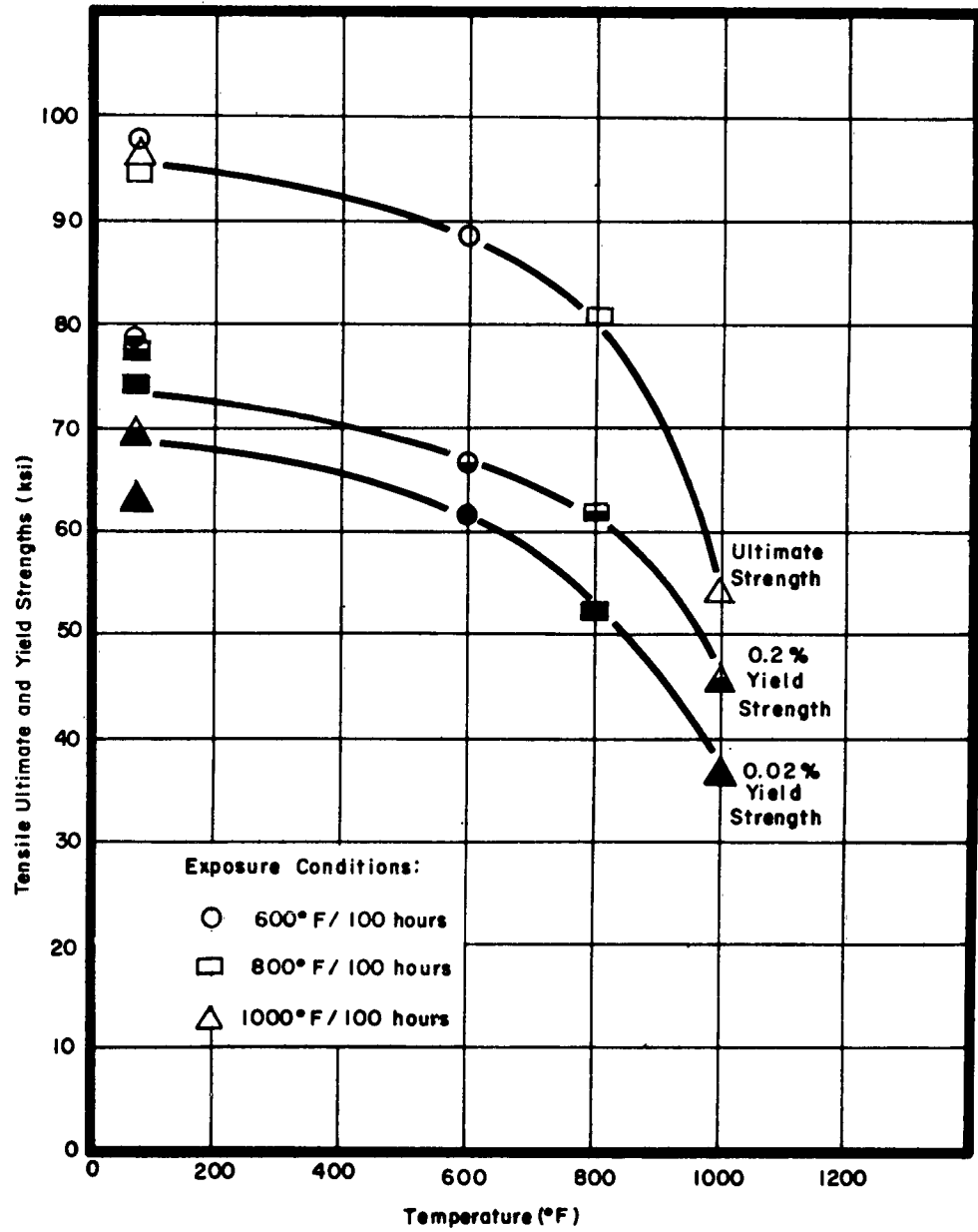

Figure 10. Effect of Temperature on Tensile Properties of Non-Stressed Stability Specimens, Potomac A

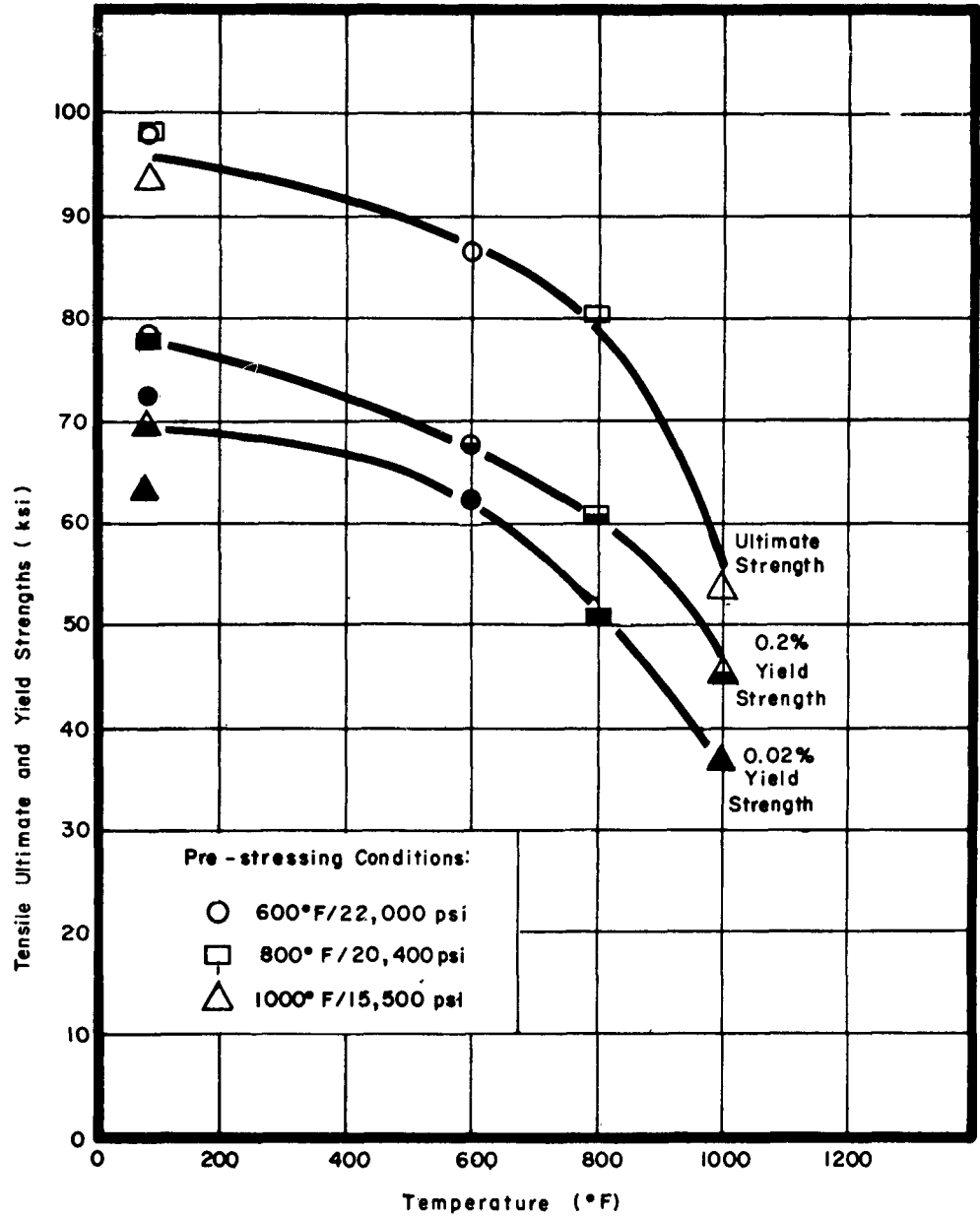

Figure 11. Effect of Temperature on Tensile Properties of Stressed Stability Specimens, Potomac A

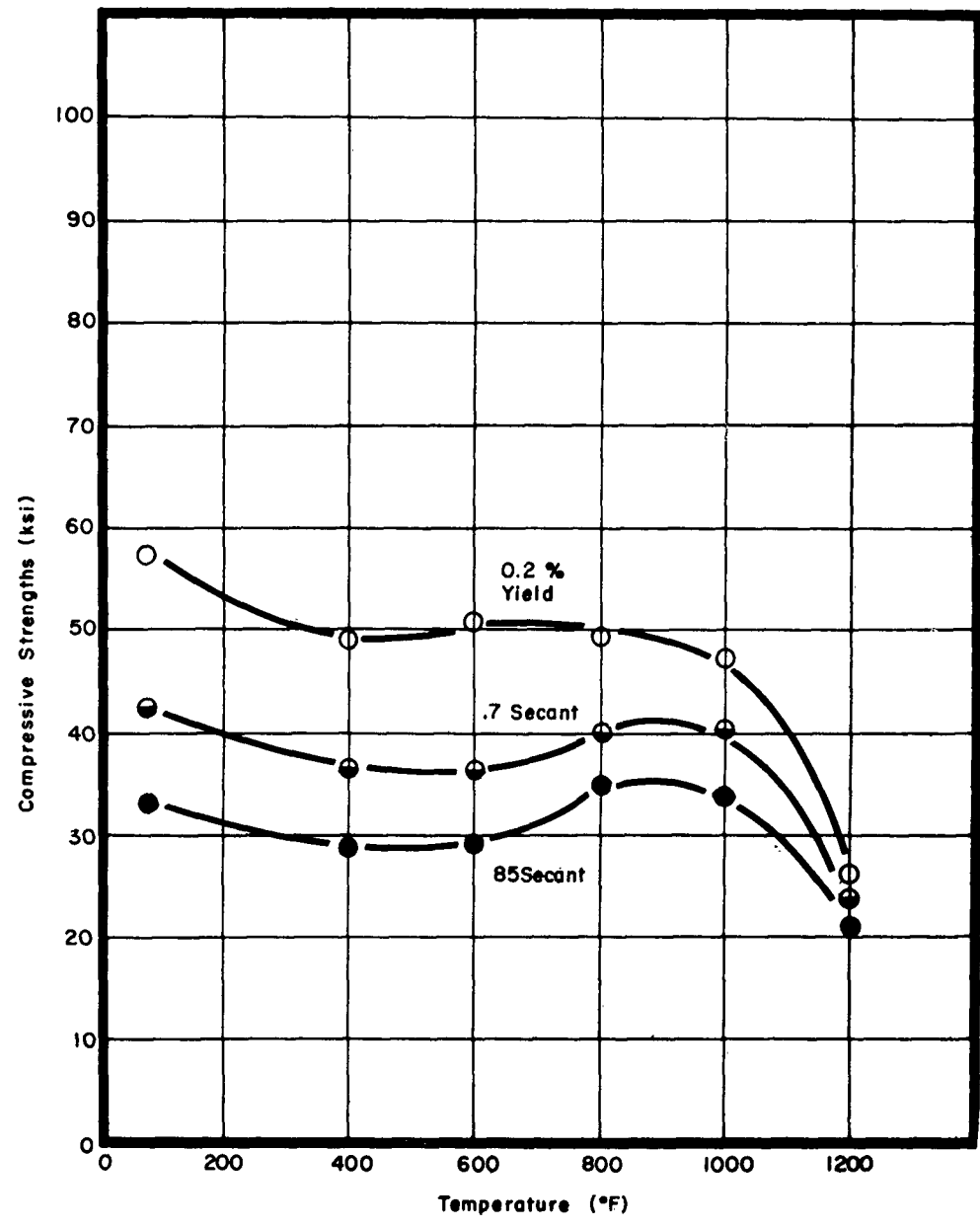

Figure 12. Effect of Temperature on Compressive Properties of Potomac A

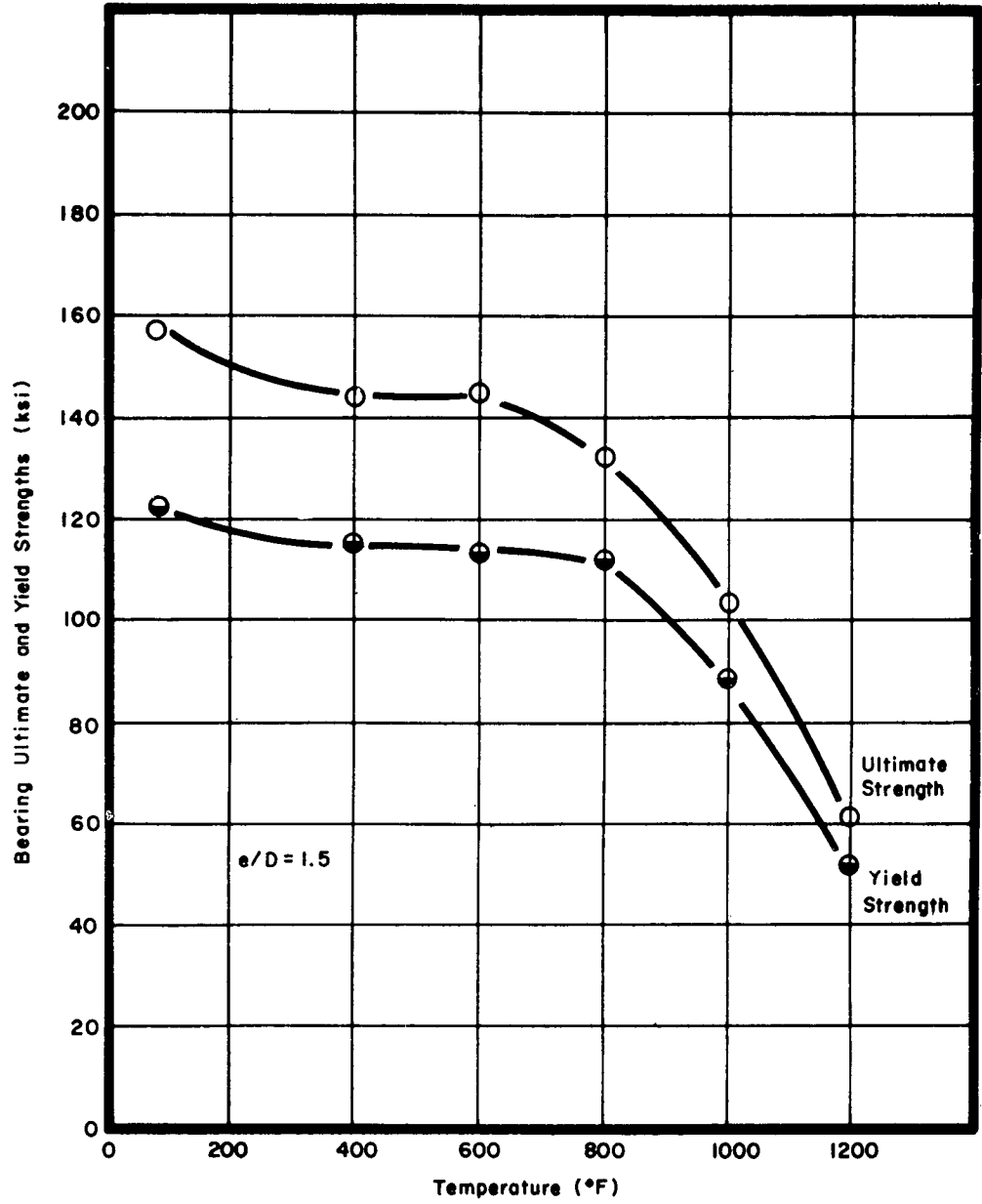

Figure 13. Effect of Temperature on Bearing Properties of Potomac A

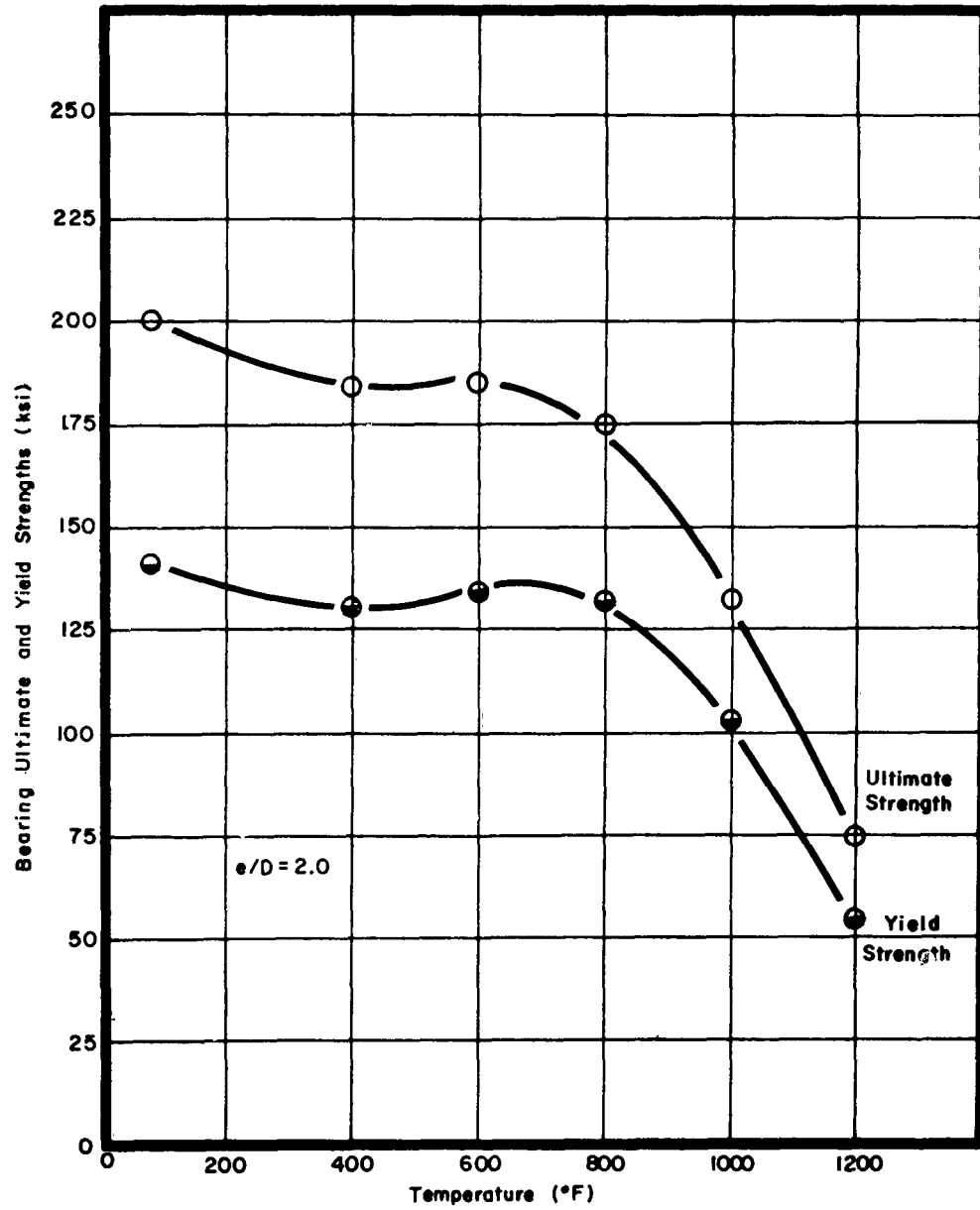

Figure 14. Effect of Temperature on Bearing Properties of Potomac A

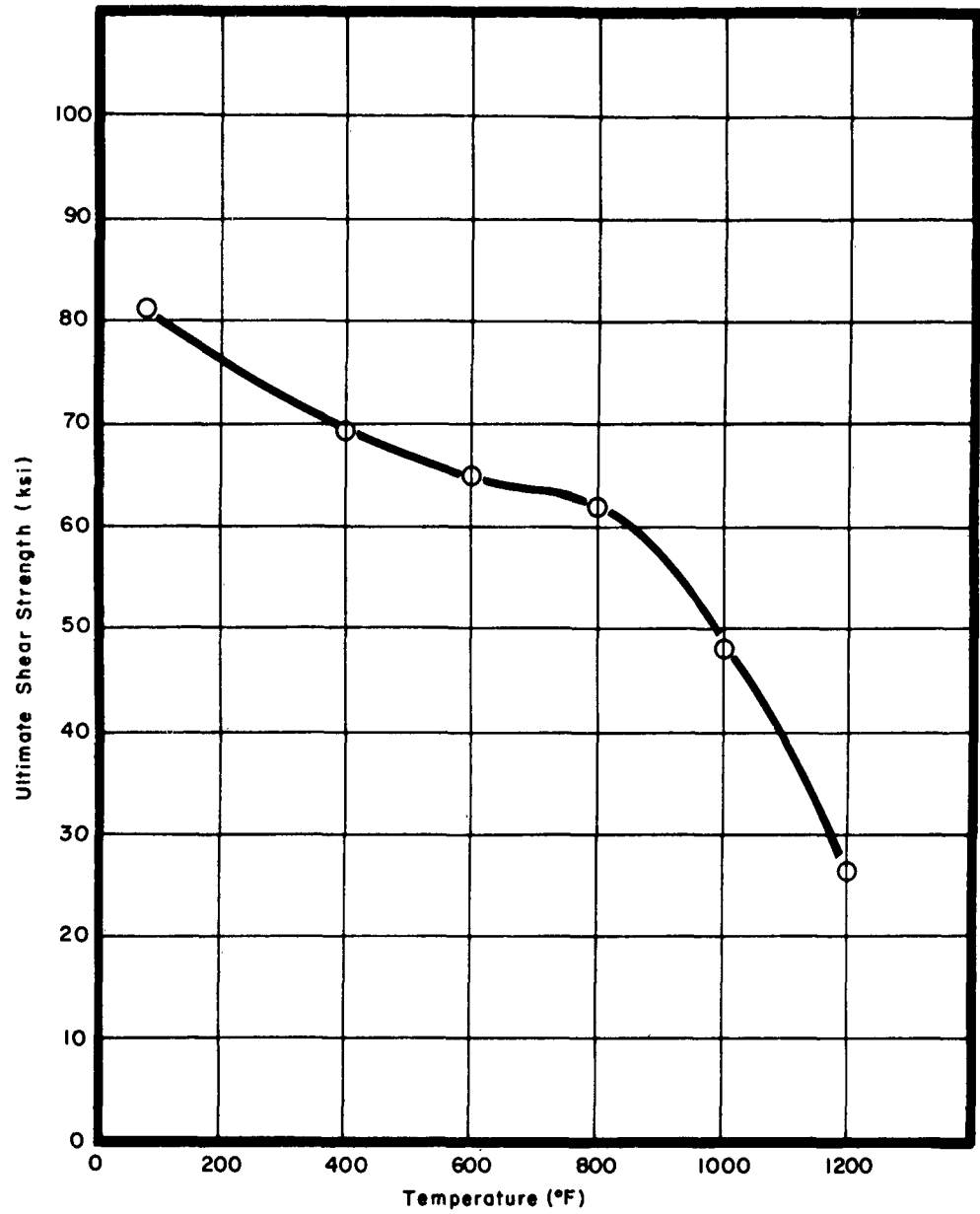

Figure 15. Effect of Temperature on Shear Strength of Potomac A

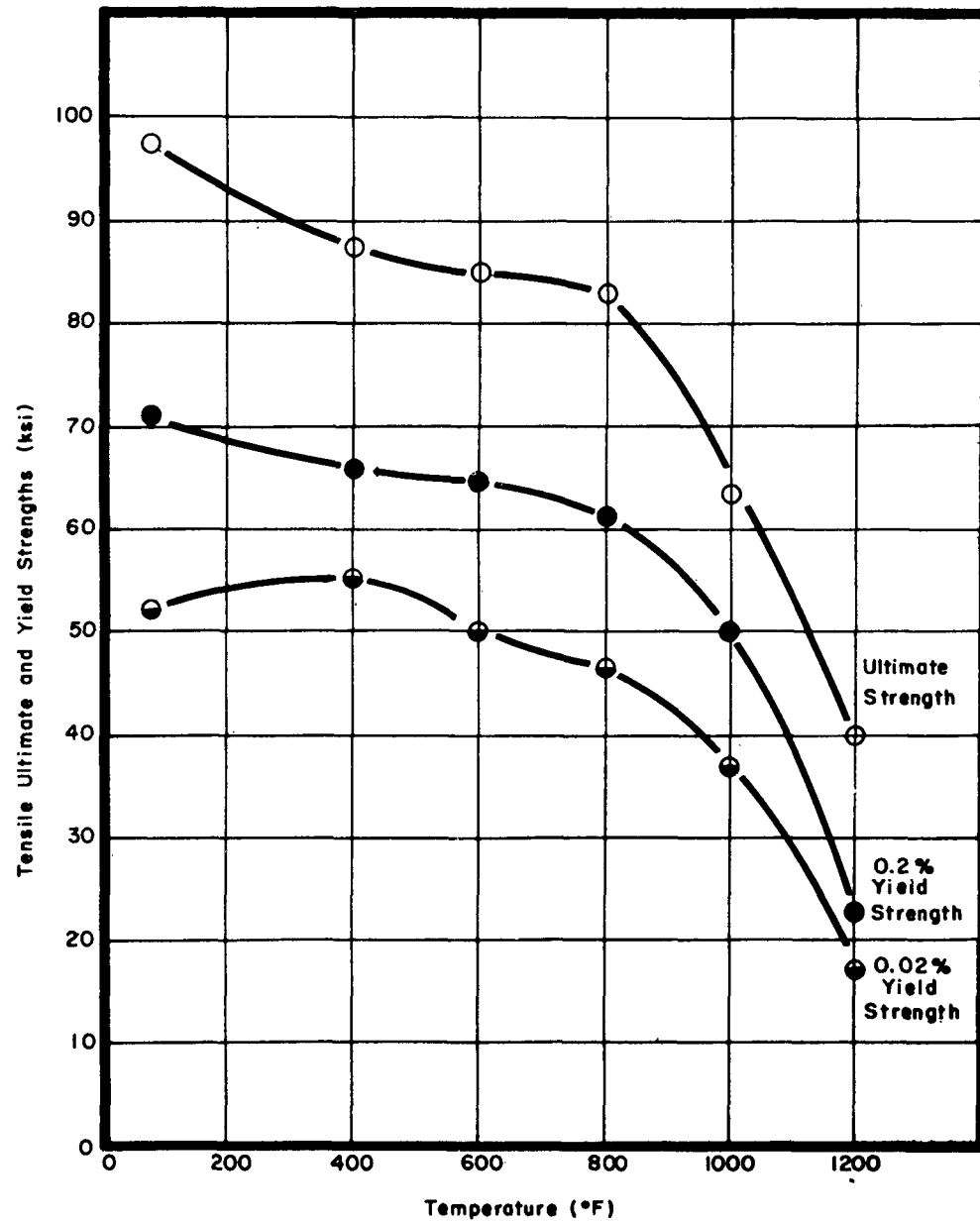

Figure 16. Effect of Temperature on Tensile Properties of Potomac M

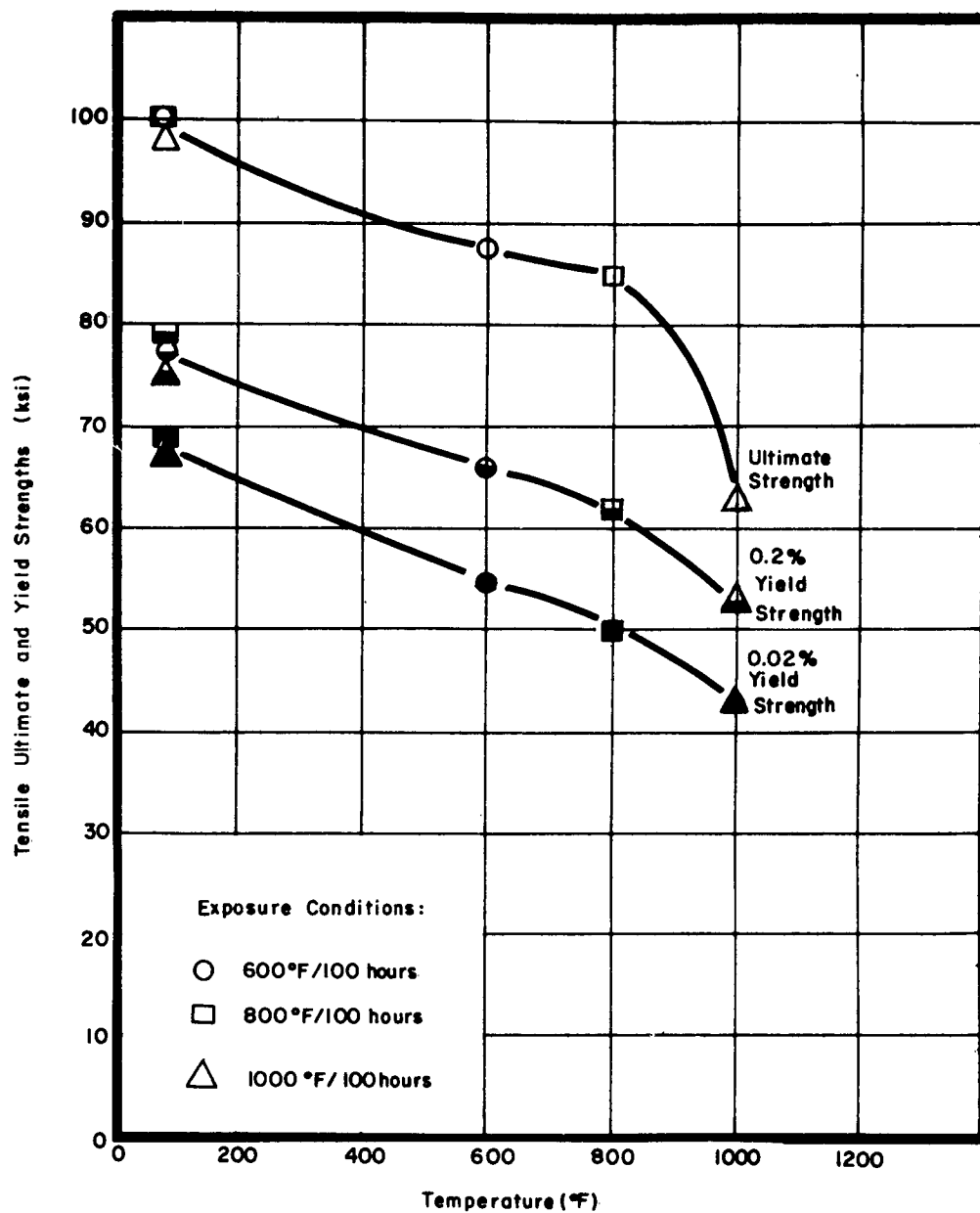

Figure 17. Effect of Temperature on Tensile Properties of Non-Stressed Stability Specimens, Potomac M

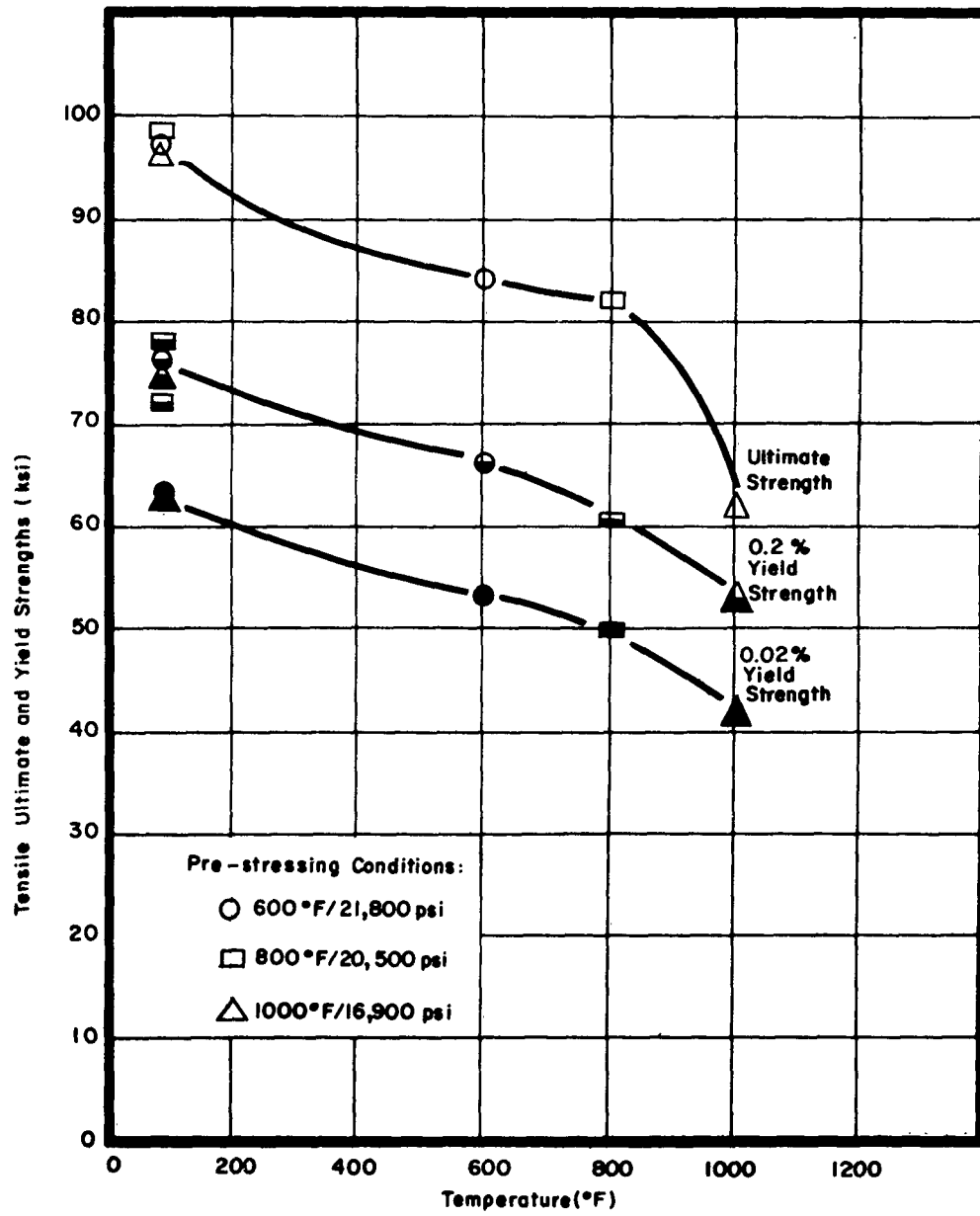

Figure 18. Effect of Temperature on Tensile Properties of Stressed Stability Specimens, Potomac M

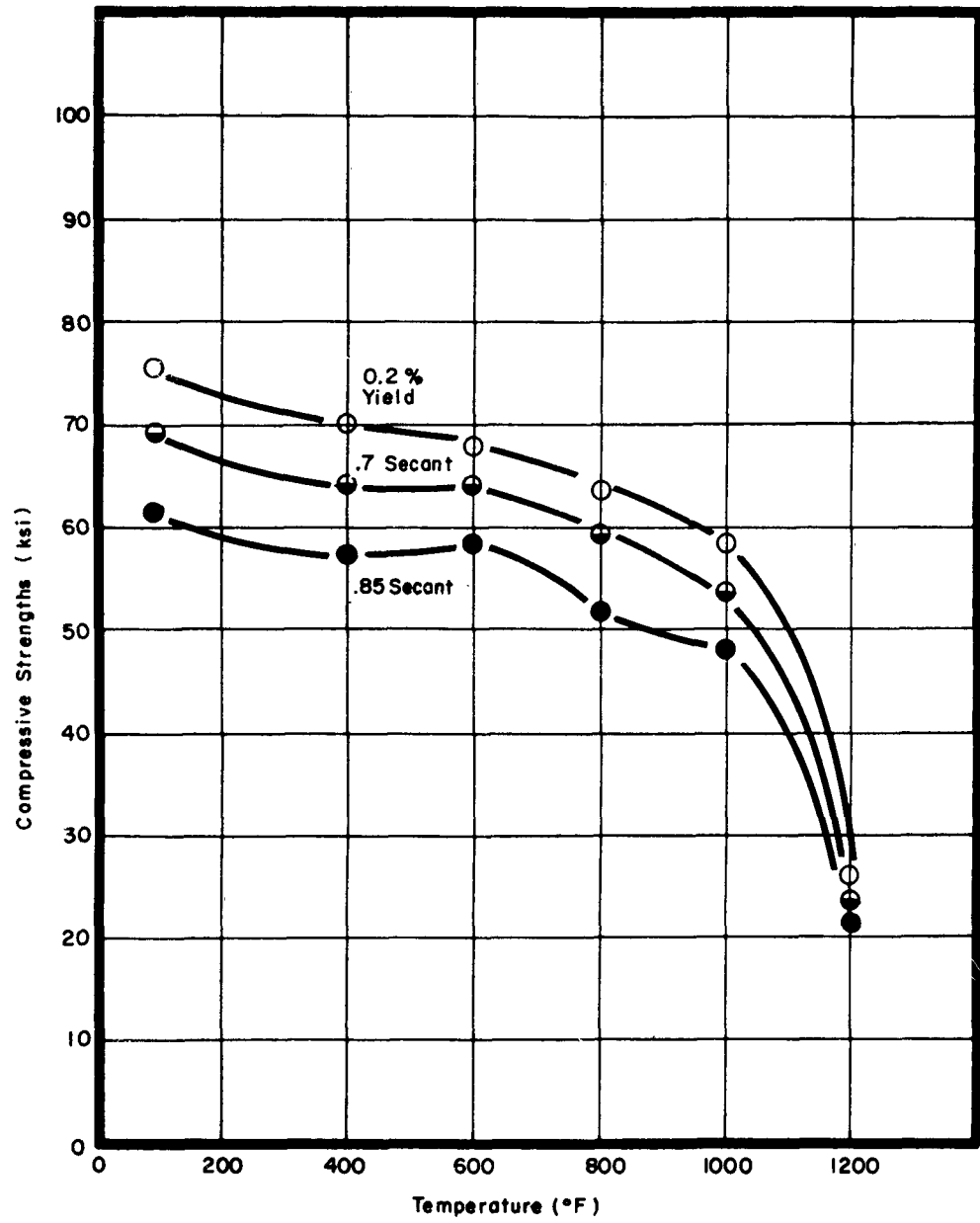

Figure 19. Effect of Temperature on Compressive Properties of Potomac M

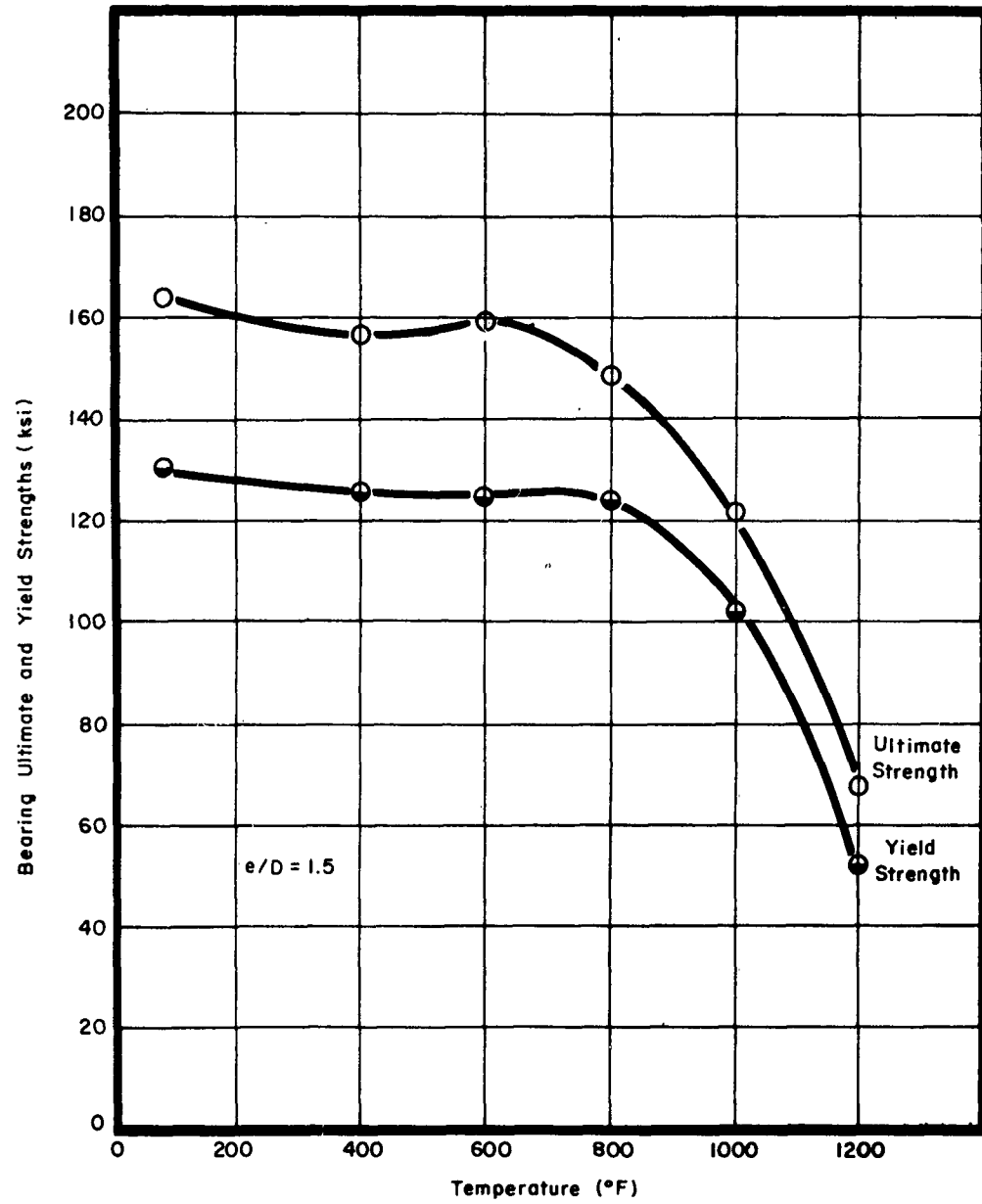

Figure 20. Effect of Temperature on Bearing Properties of Potomac M

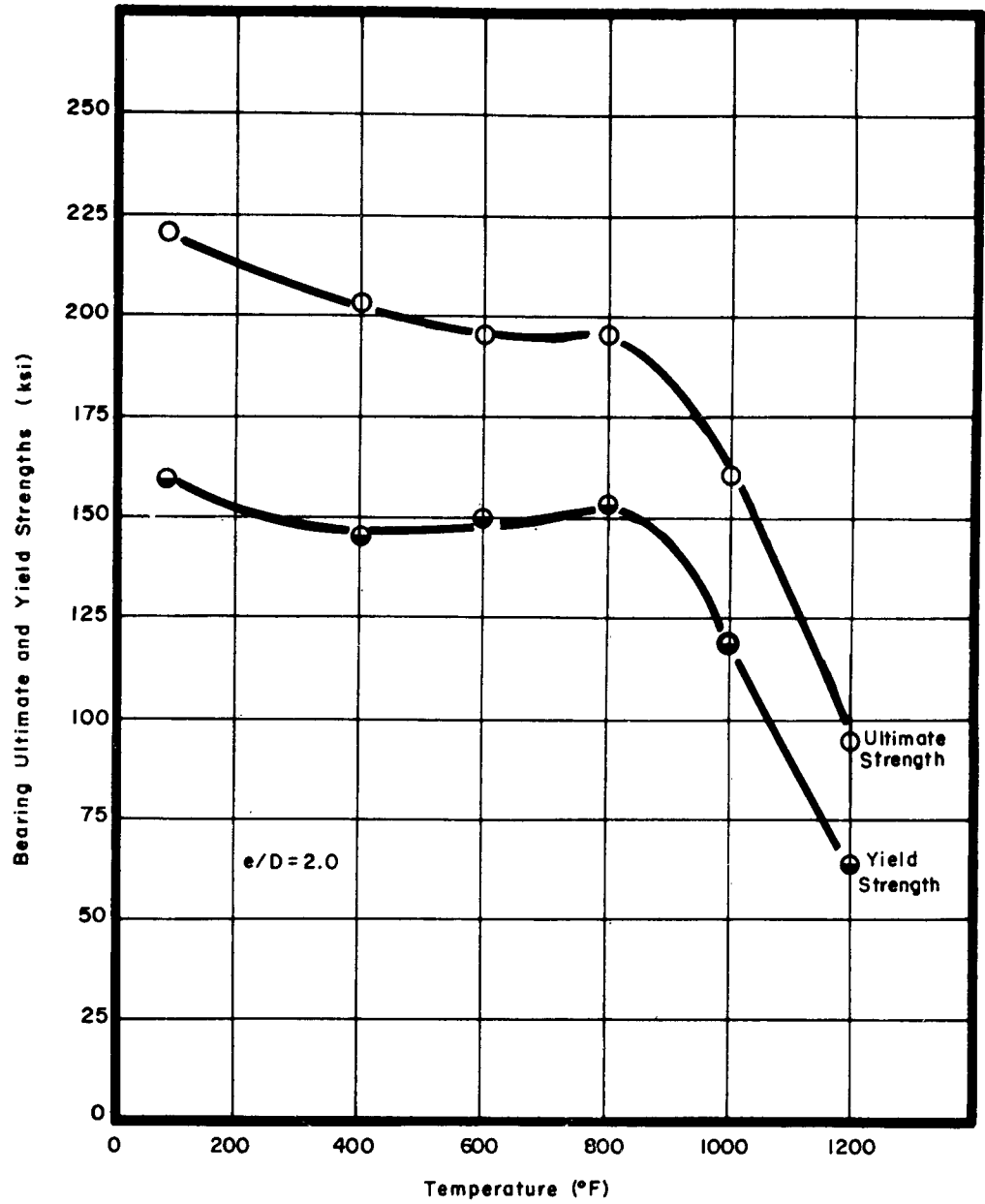

Figure 21. Effect of Temperature on Bearing Properties of Potomac M

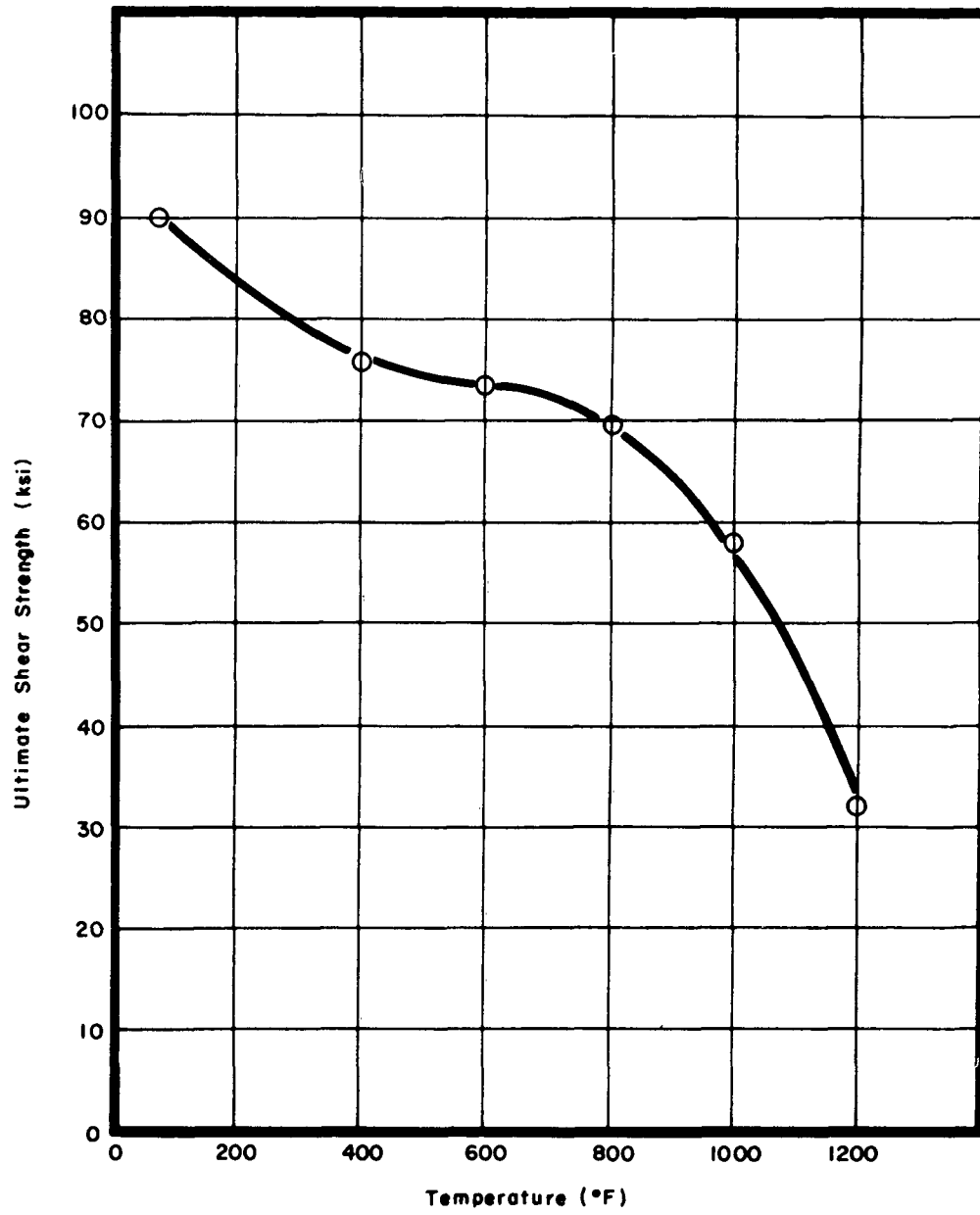

Figure 22. Effect of Temperature on Shear Strength of Potomac M

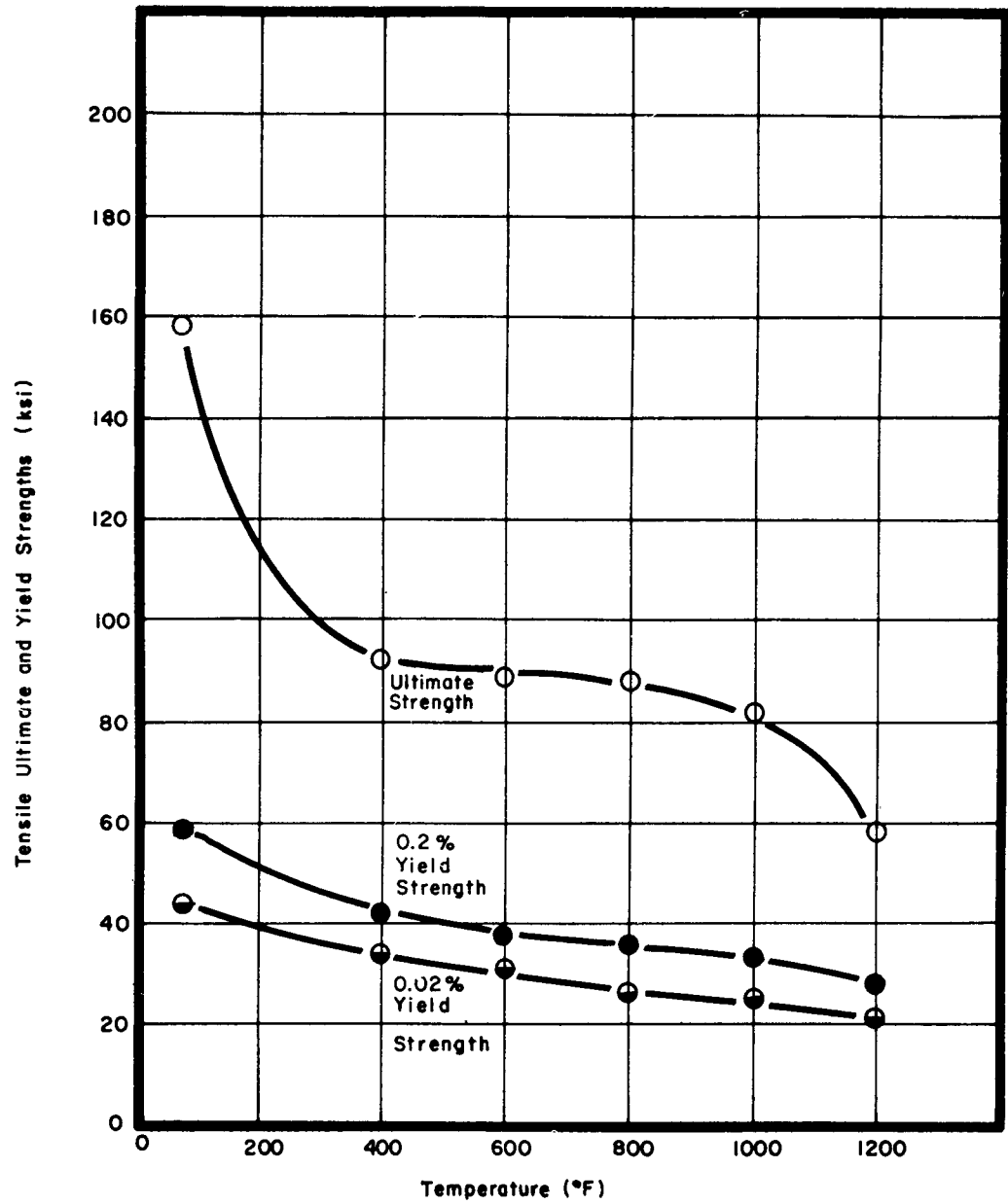

Figure 23. Effect of Temperature on Tensile Properties of AM-350

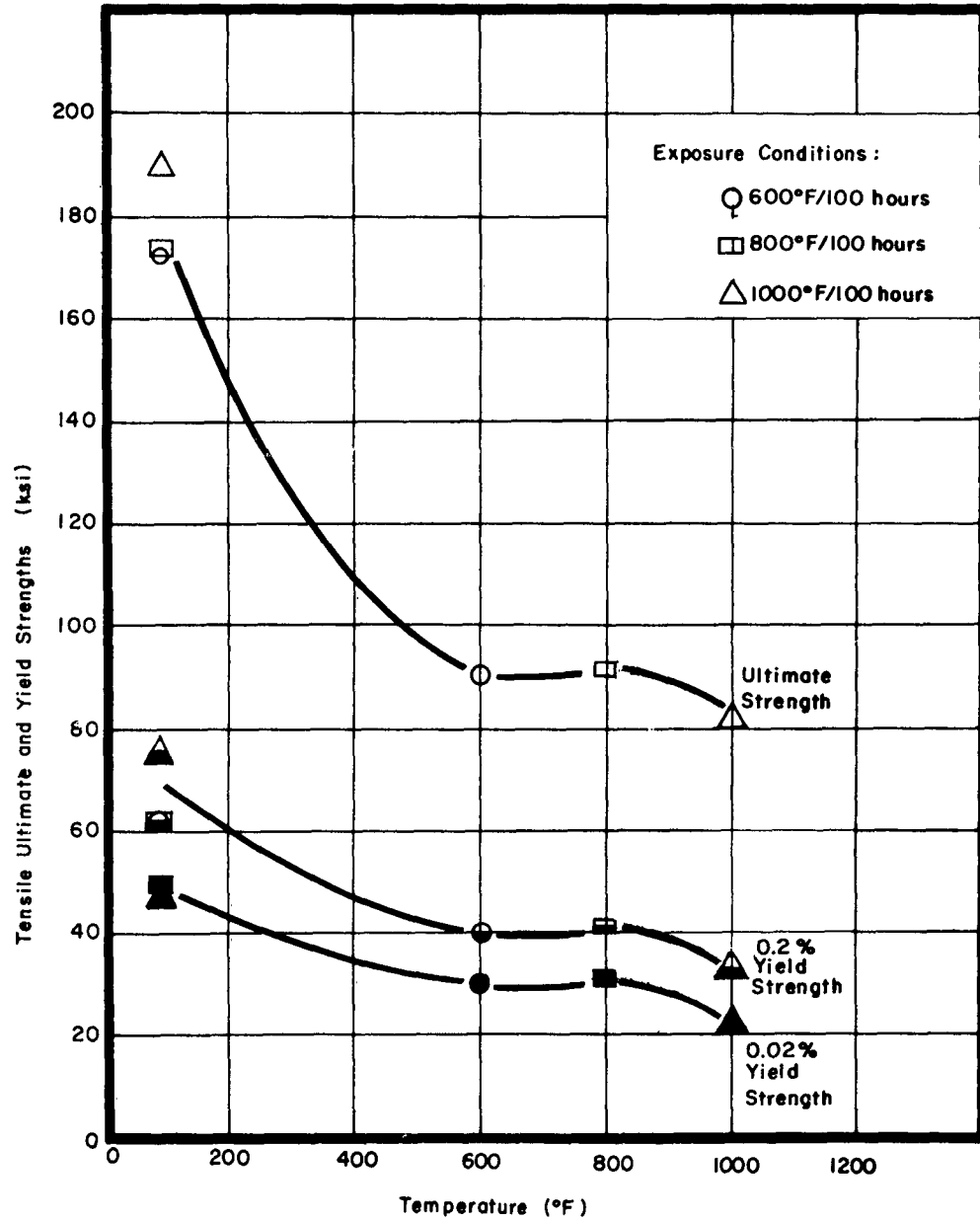

Figure 24. Effect of Temperature on Tensile Properties of Non-Stressed Stability Specimens, AM-350

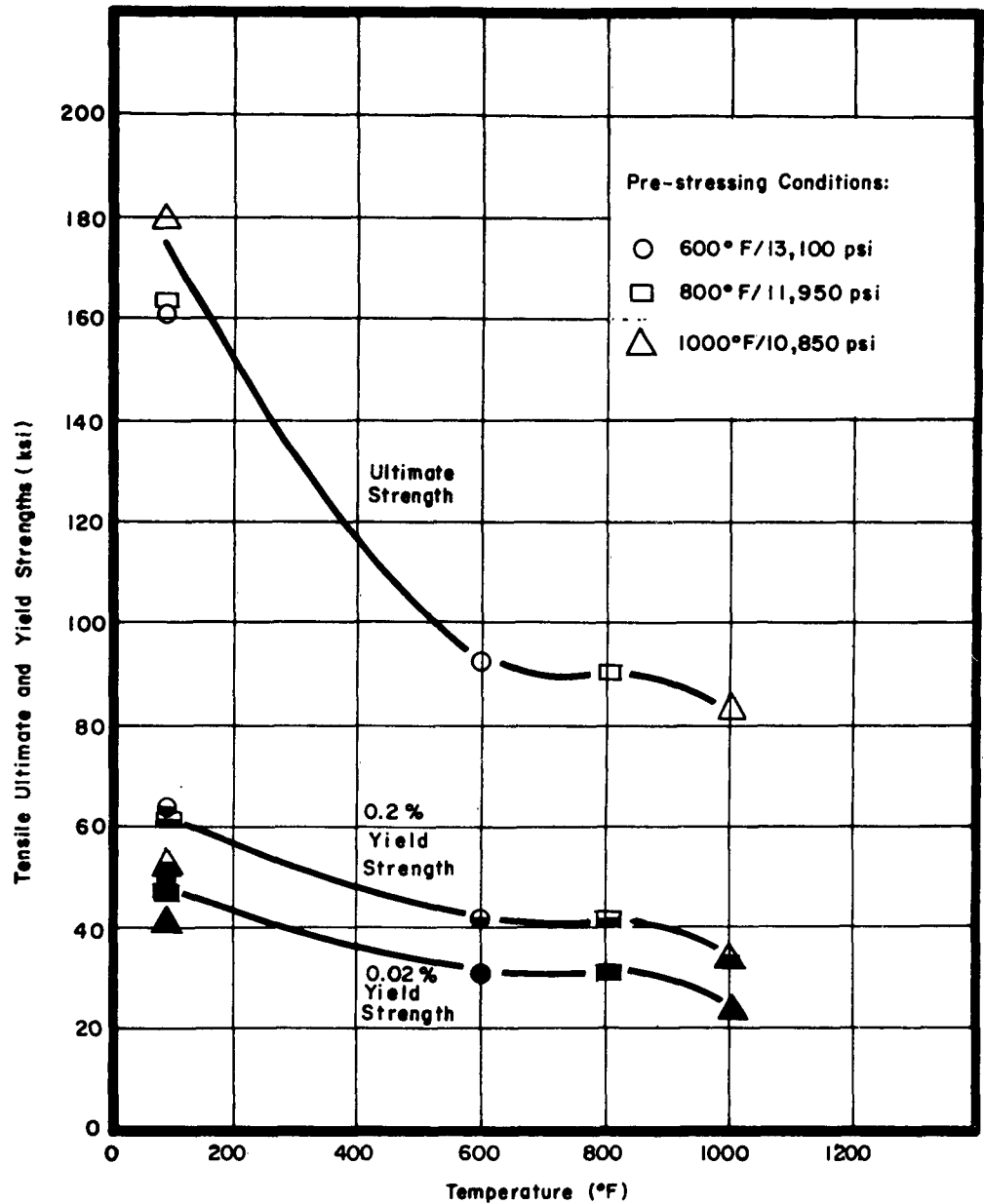

Figure 25. Effect of Temperature on Tensile Properties of Stressed Stability Specimens, AM-350

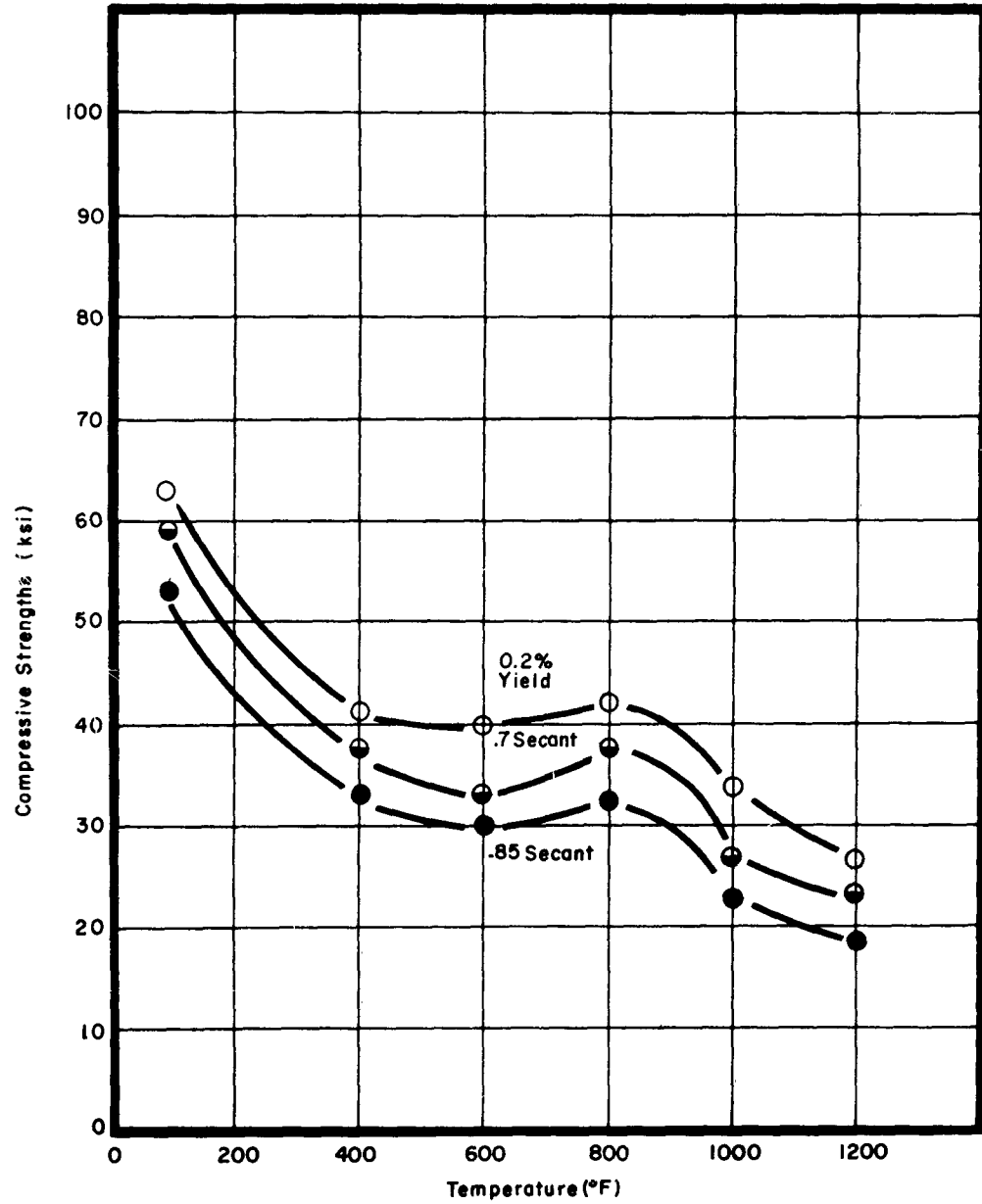

Figure 26. Effect of Temperature on Compressive Properties of AM-350

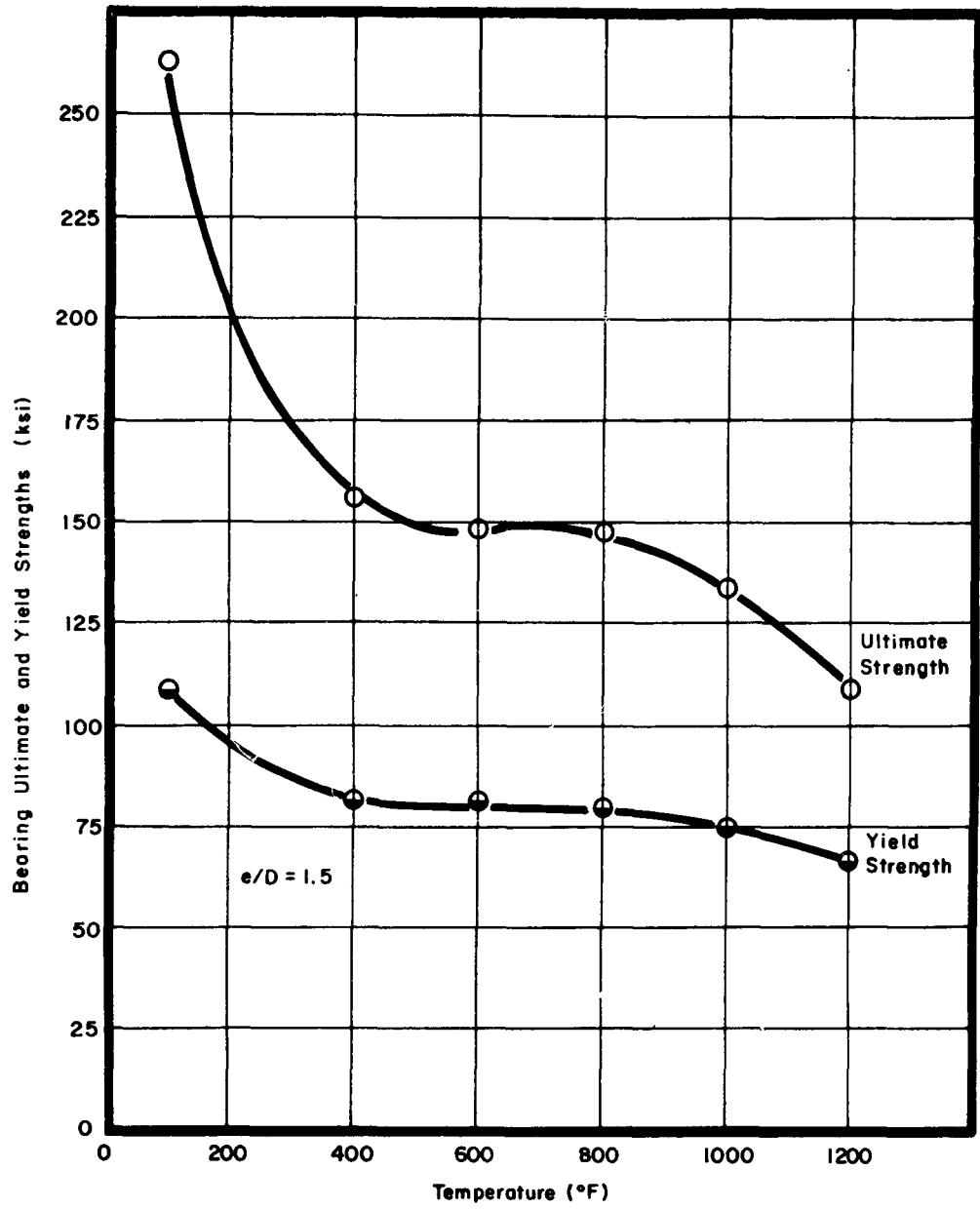

Figure 27. Effect of Temperature on Bearing Properties of AM-350

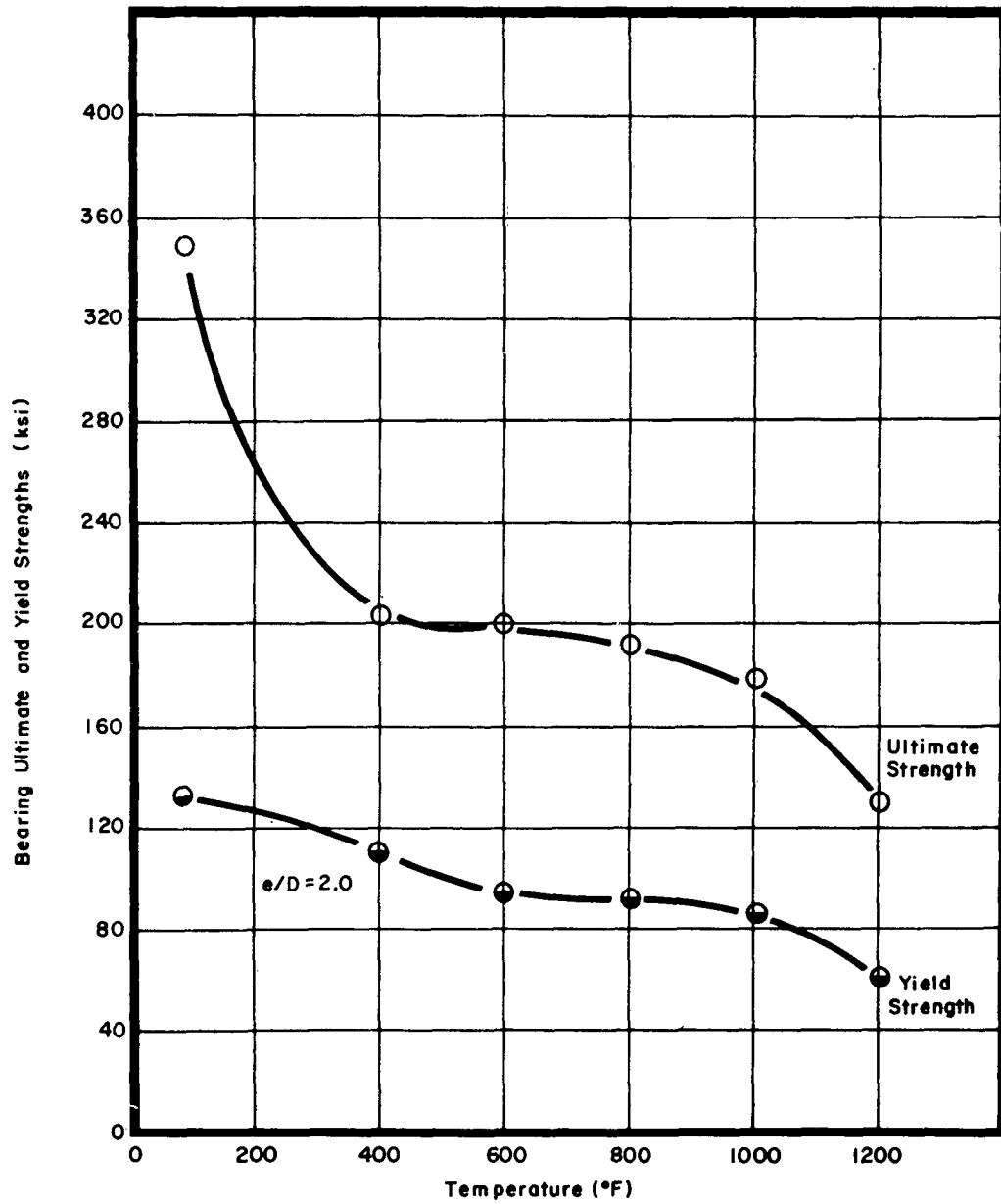

Figure 28. Effect of Temperature on Bearing Properties of AM-350

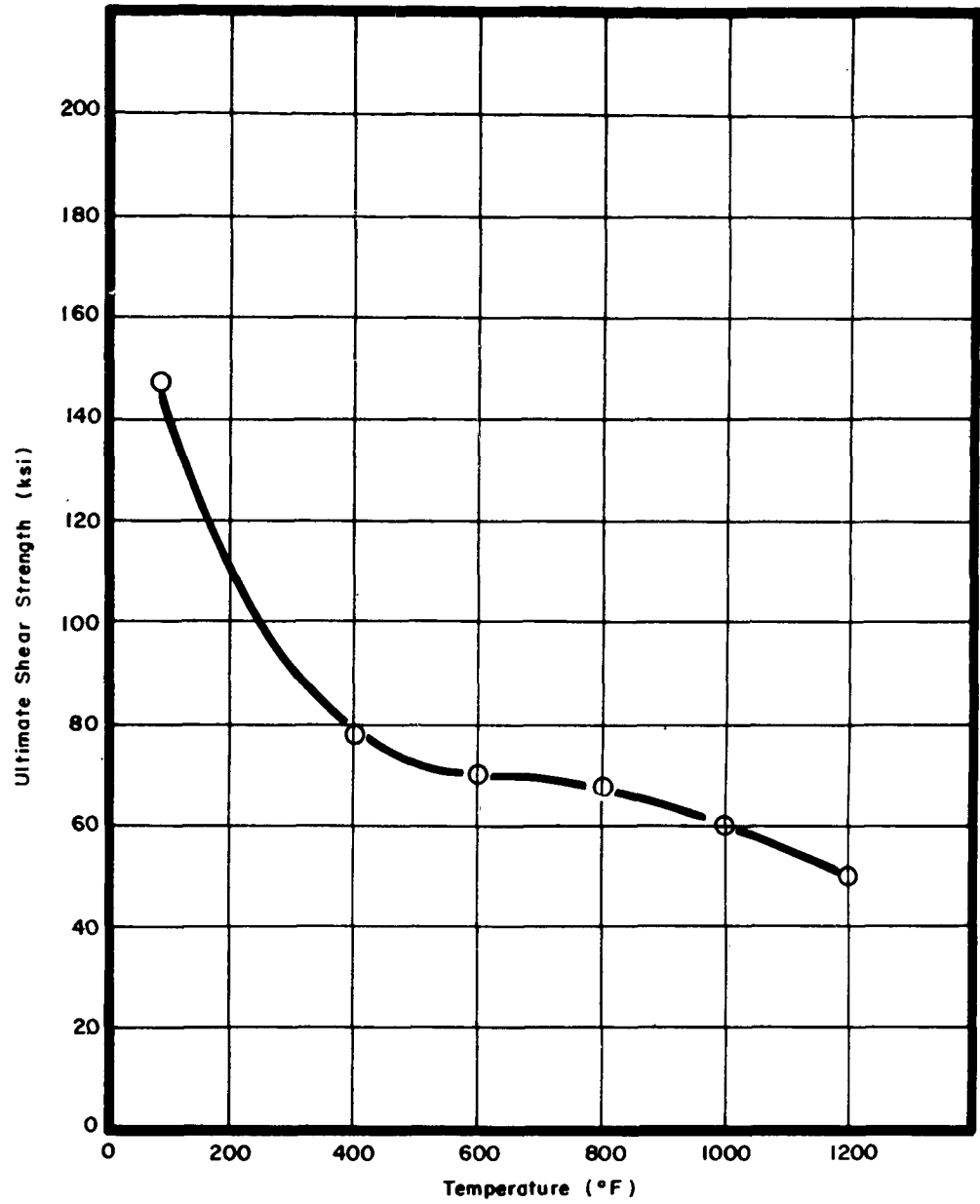

Figure 29. Effect of Temperature on Shear Strength of AM-350

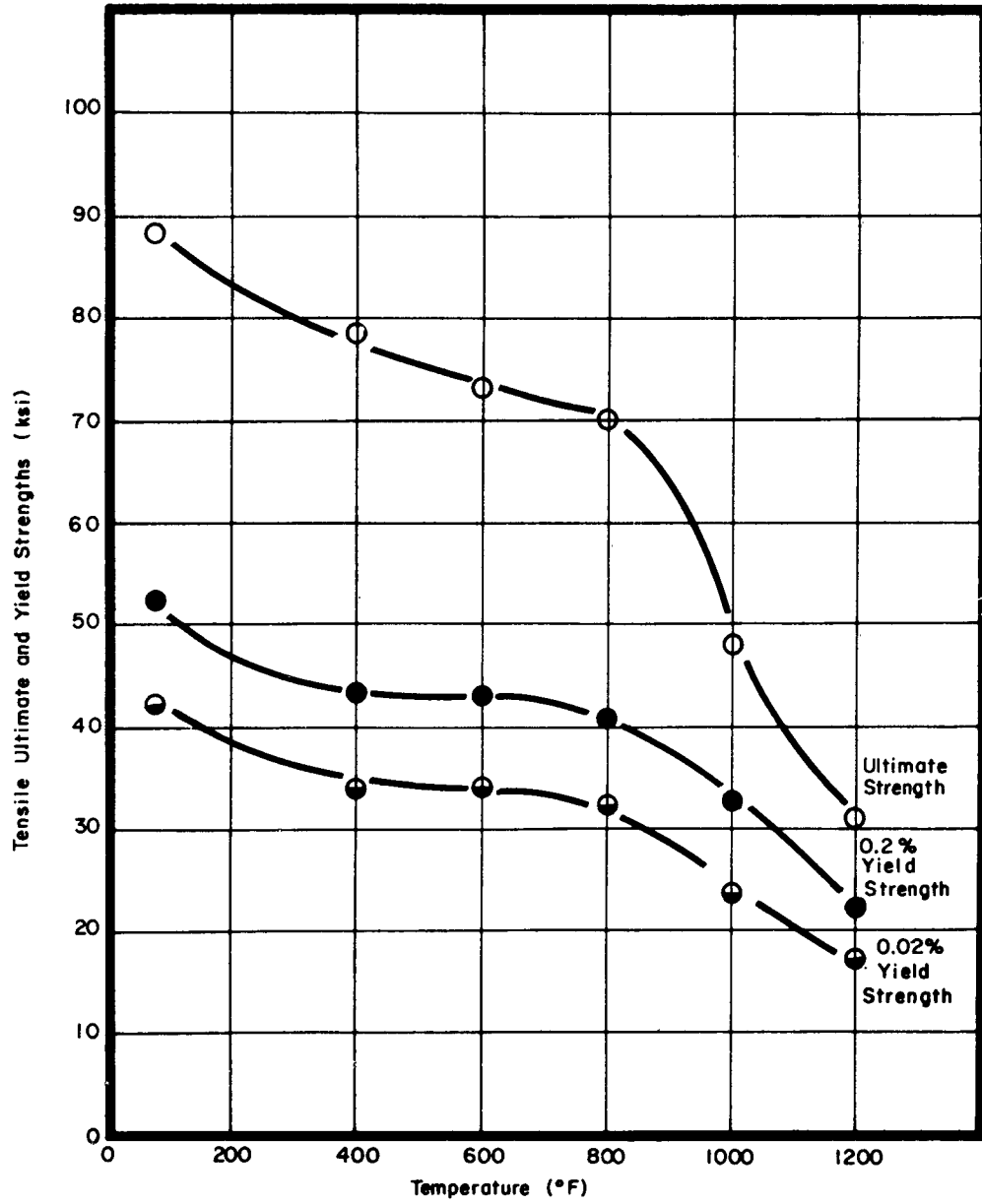

Figure 30. Effect of Temperature on Tensile Properties of Vasco Jet-1000

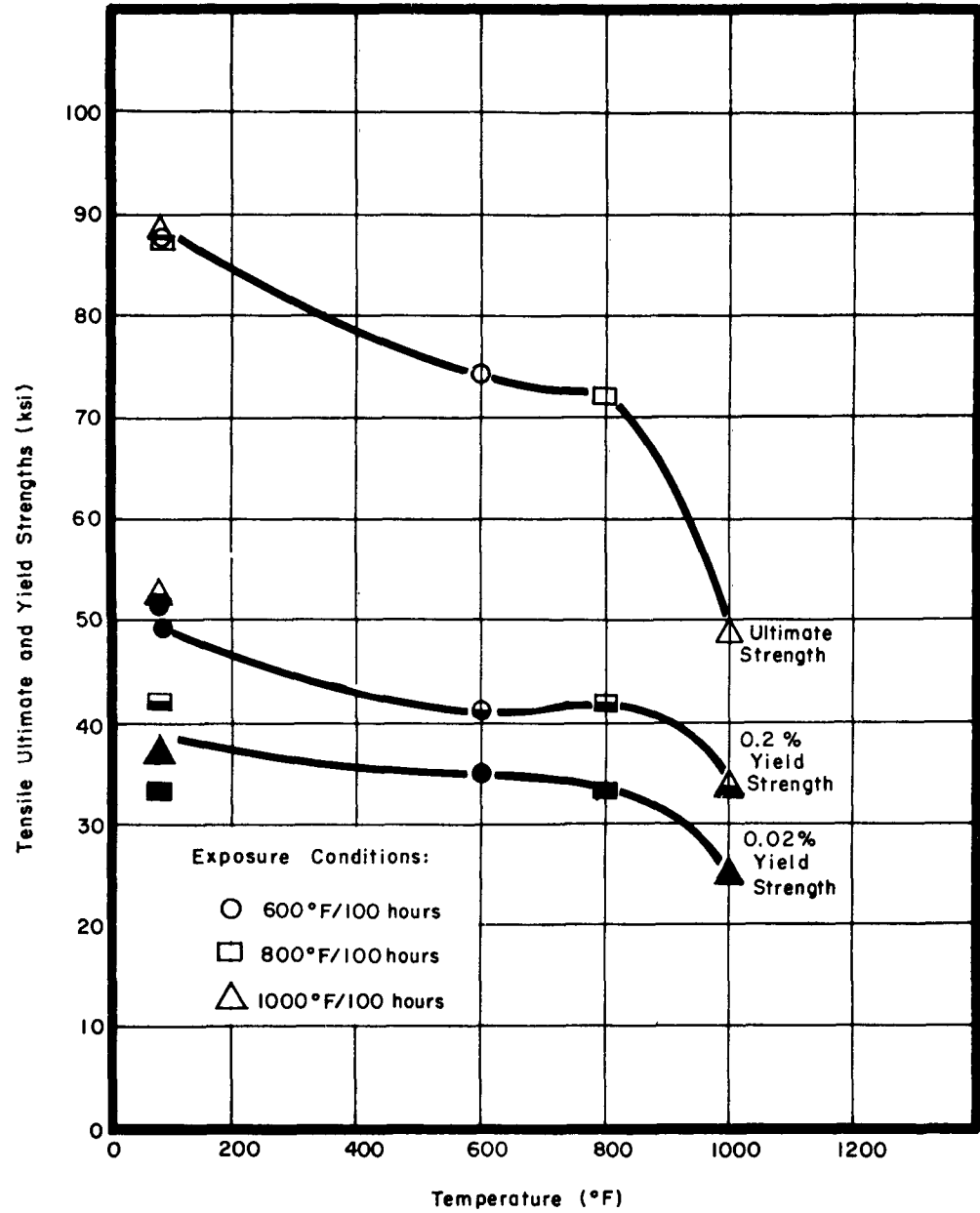

Figure 31. Effect of Temperature on Tensile Properties of Non-Stressed Stability Specimens, Vasco Jet-1000

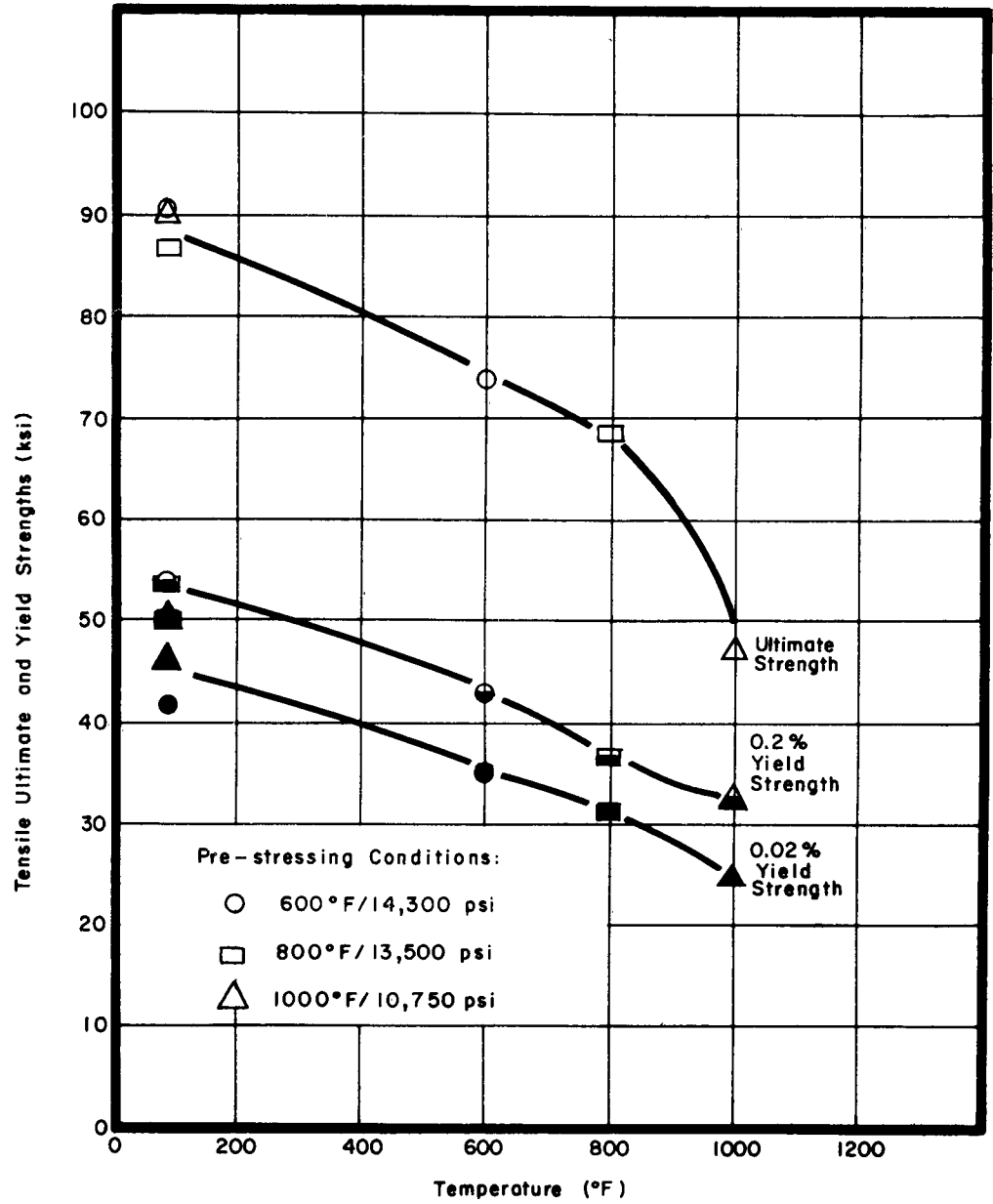

Figure 32. Effect of Temperature on Tensile Properties of Stressed Stability Specimens, Vasco Jet-1000

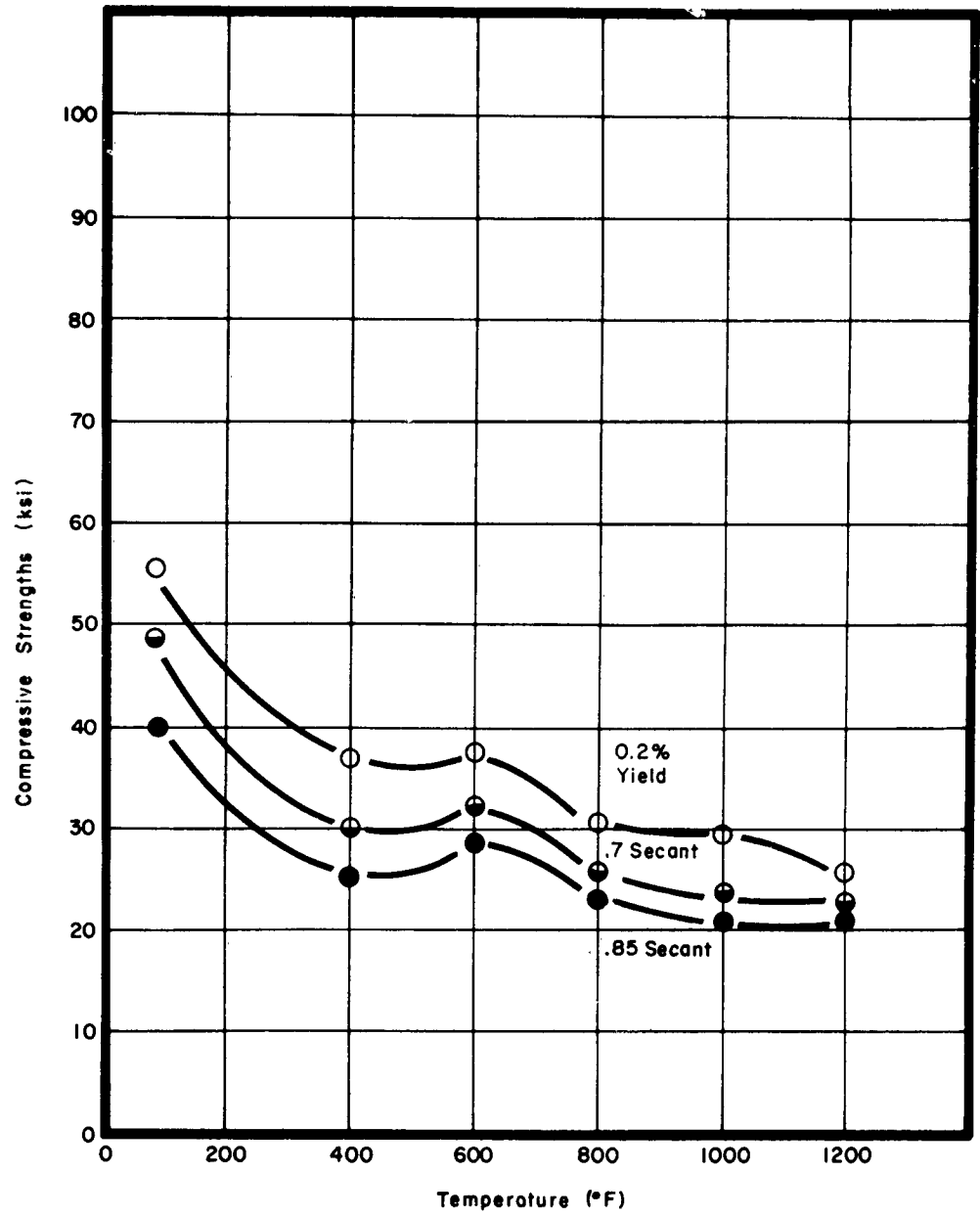

Figure 33. Effect of Temperature on Compressive Properties of Vasco Jet-1000

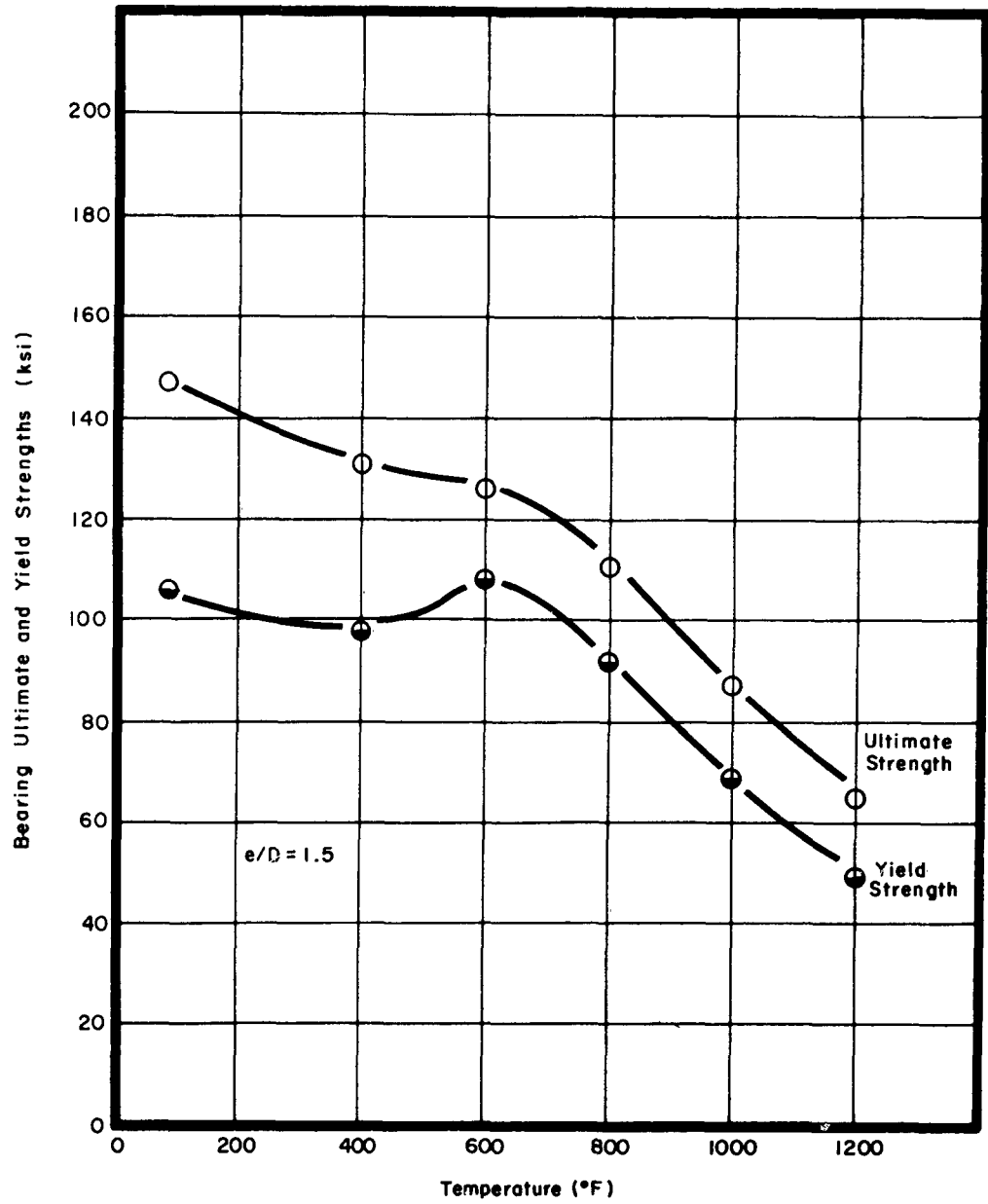

Figure 34. Effect of Temperature on Bearing Properties of Vasco Jet-1000

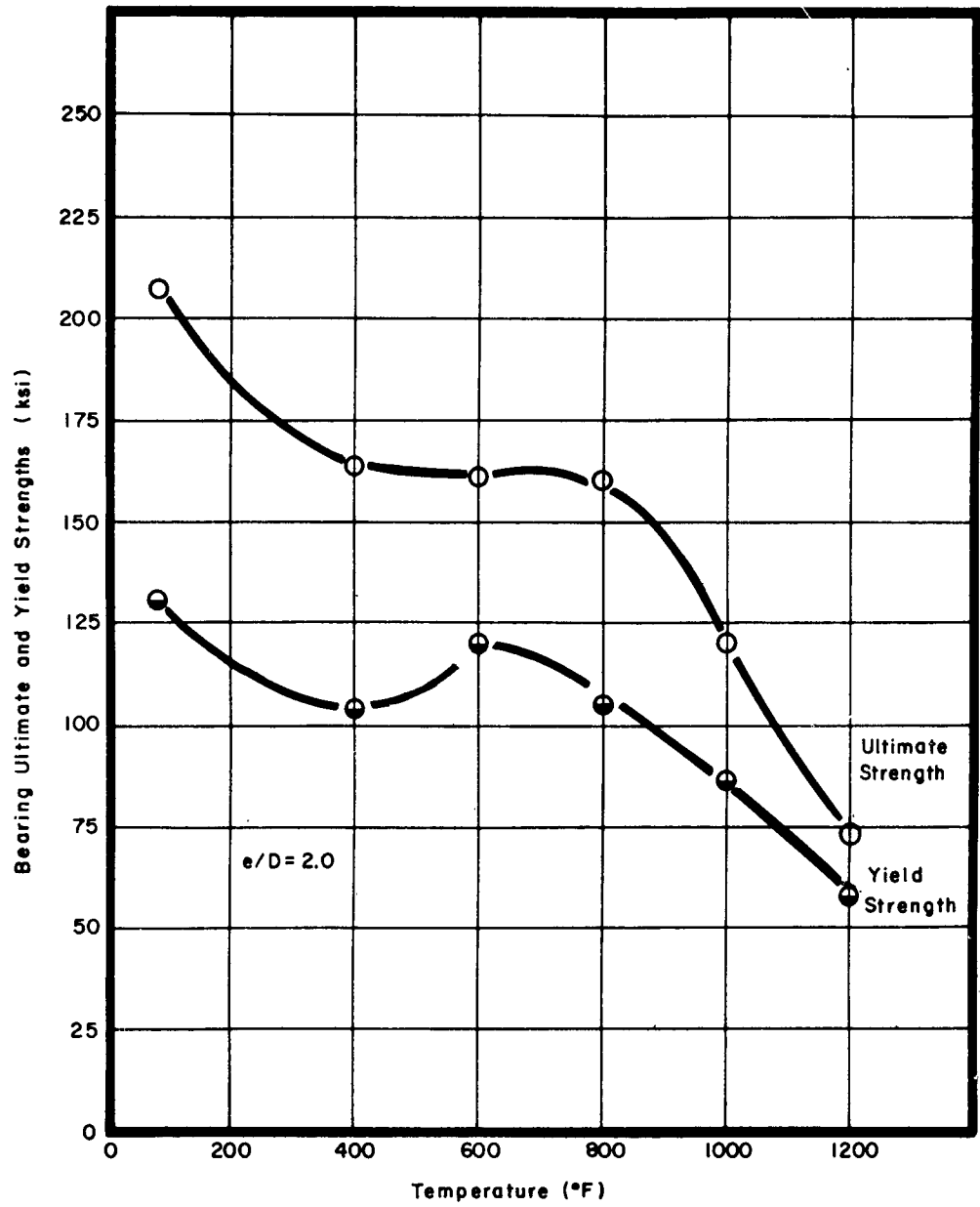

Figure 35. Effect of Temperature on Bearing Properties of Vasco Jet-1000

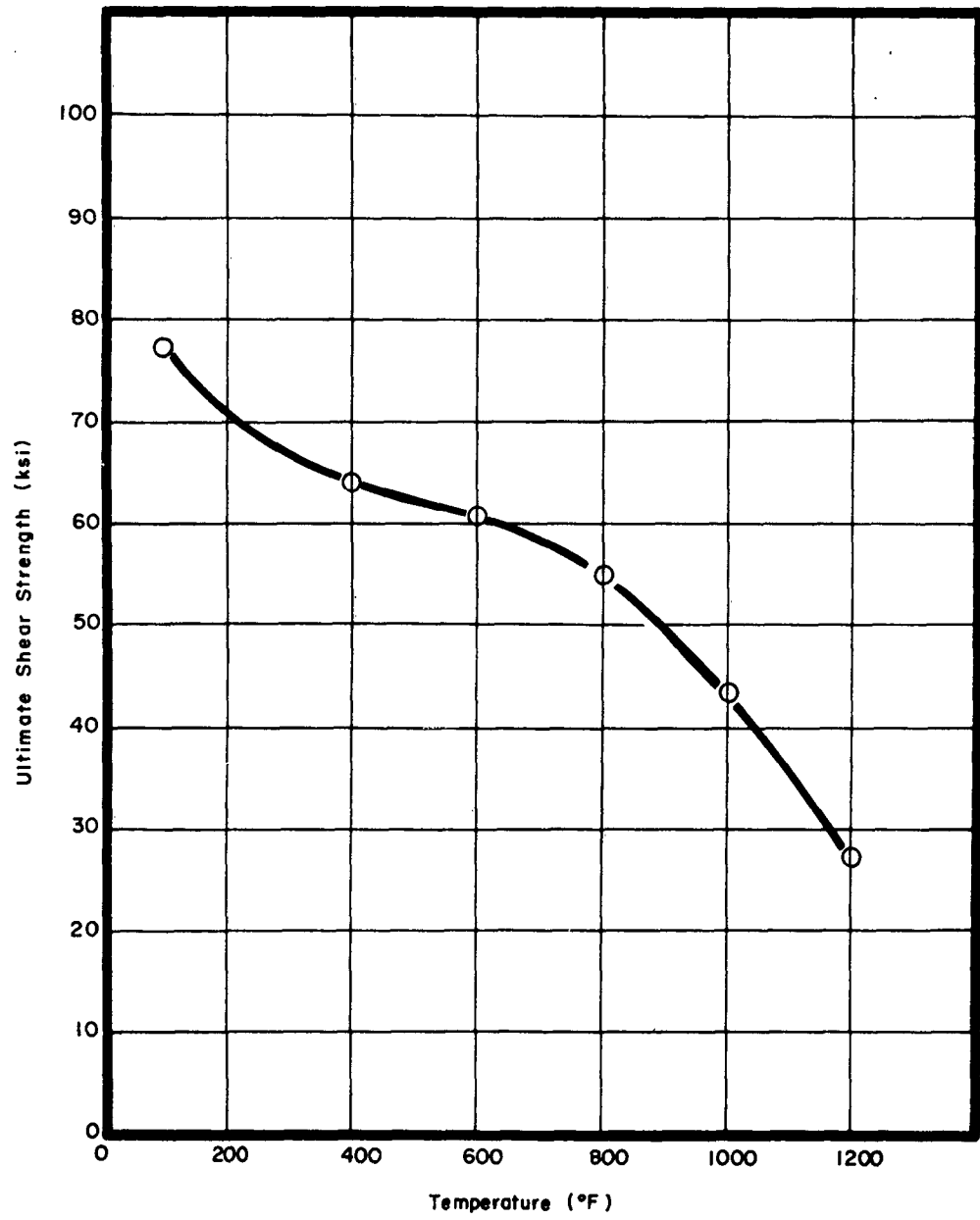

Figure 36. Effect of Temperature on Shear Strength of Vasco Jet-1000

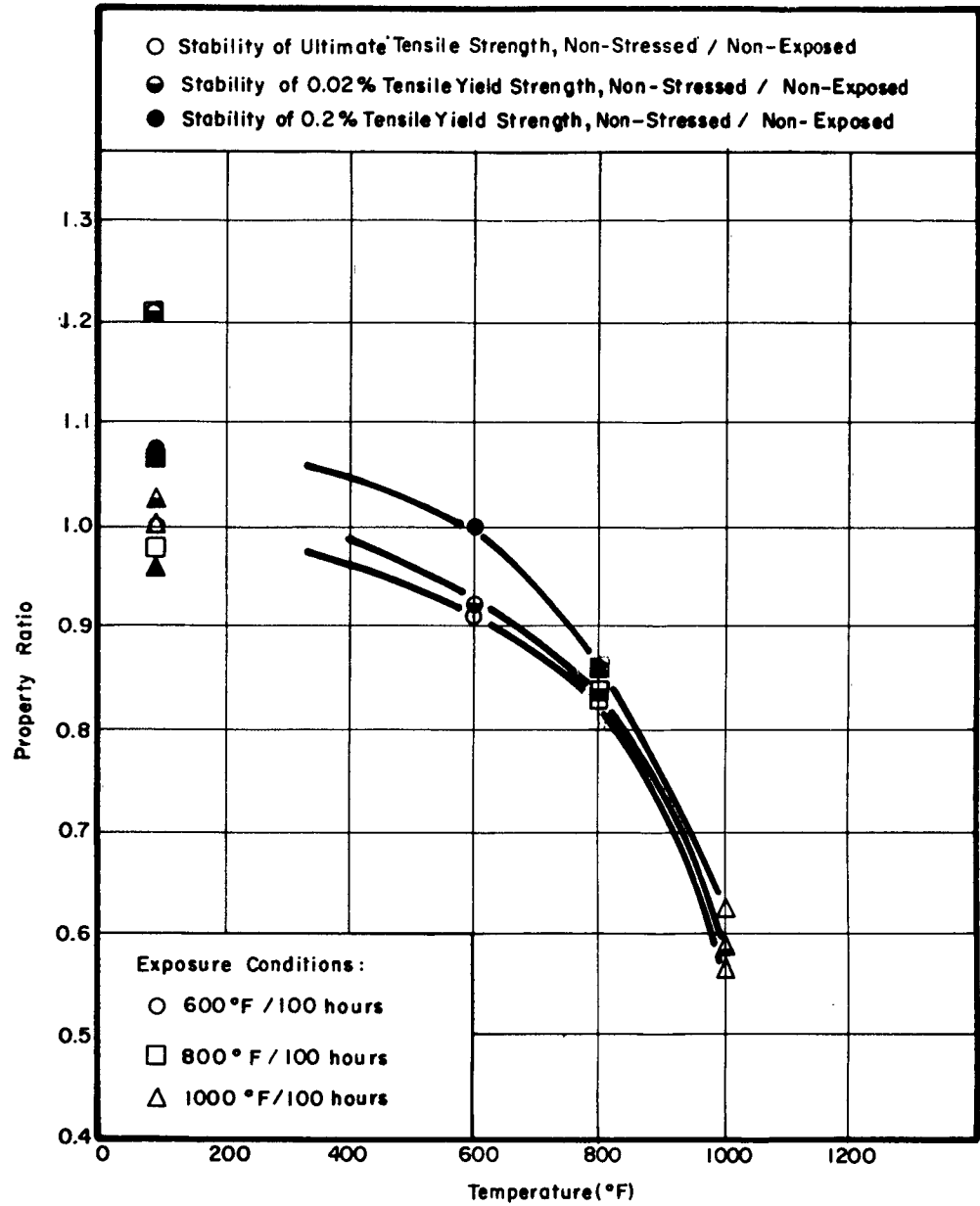

Figure 37. Effect of Exposure Time and Temperature Versus Non-Stressed Tensile Stability/Tensile Properties of Non-Exposed Potomac A

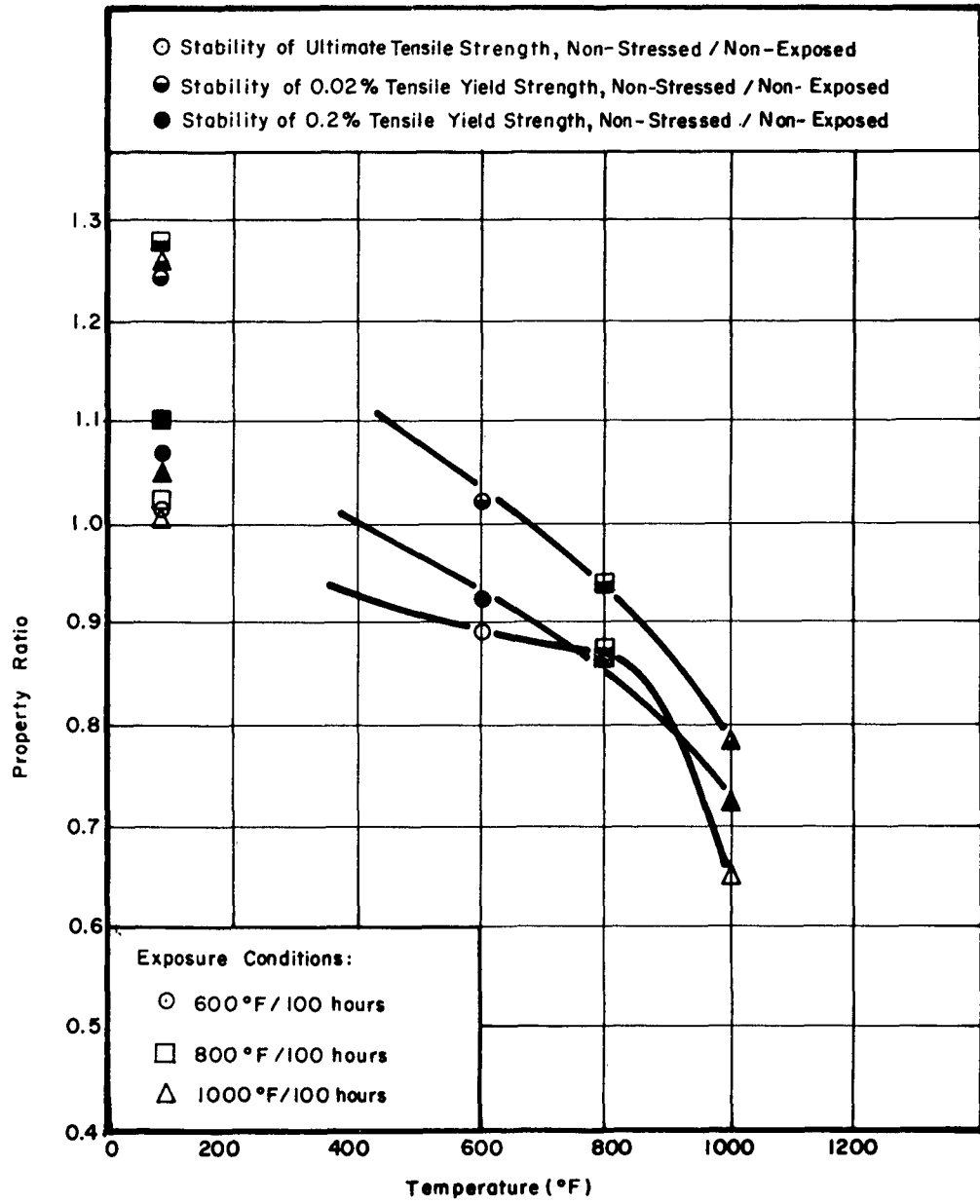

Figure 38. Effect of Exposure Time and Temperature Versus Non-Stressed Tensile Stability/Tensile Properties of Non-Exposed Potomac M

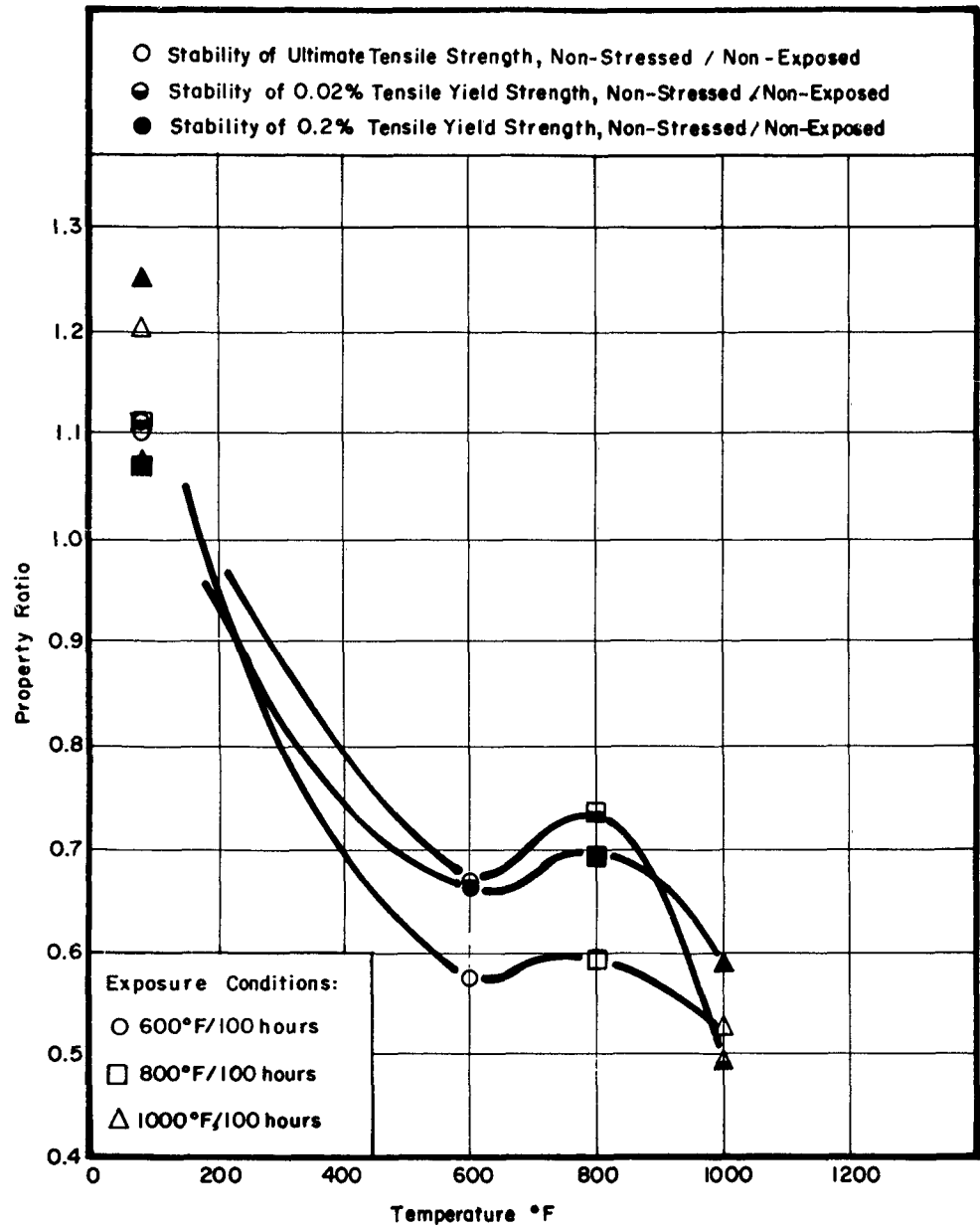

Figure 39. Effect of Exposure Time and Temperature Versus Non-Stressed Tensile Stability/Tensile Properties of Non-Exposed AM-350

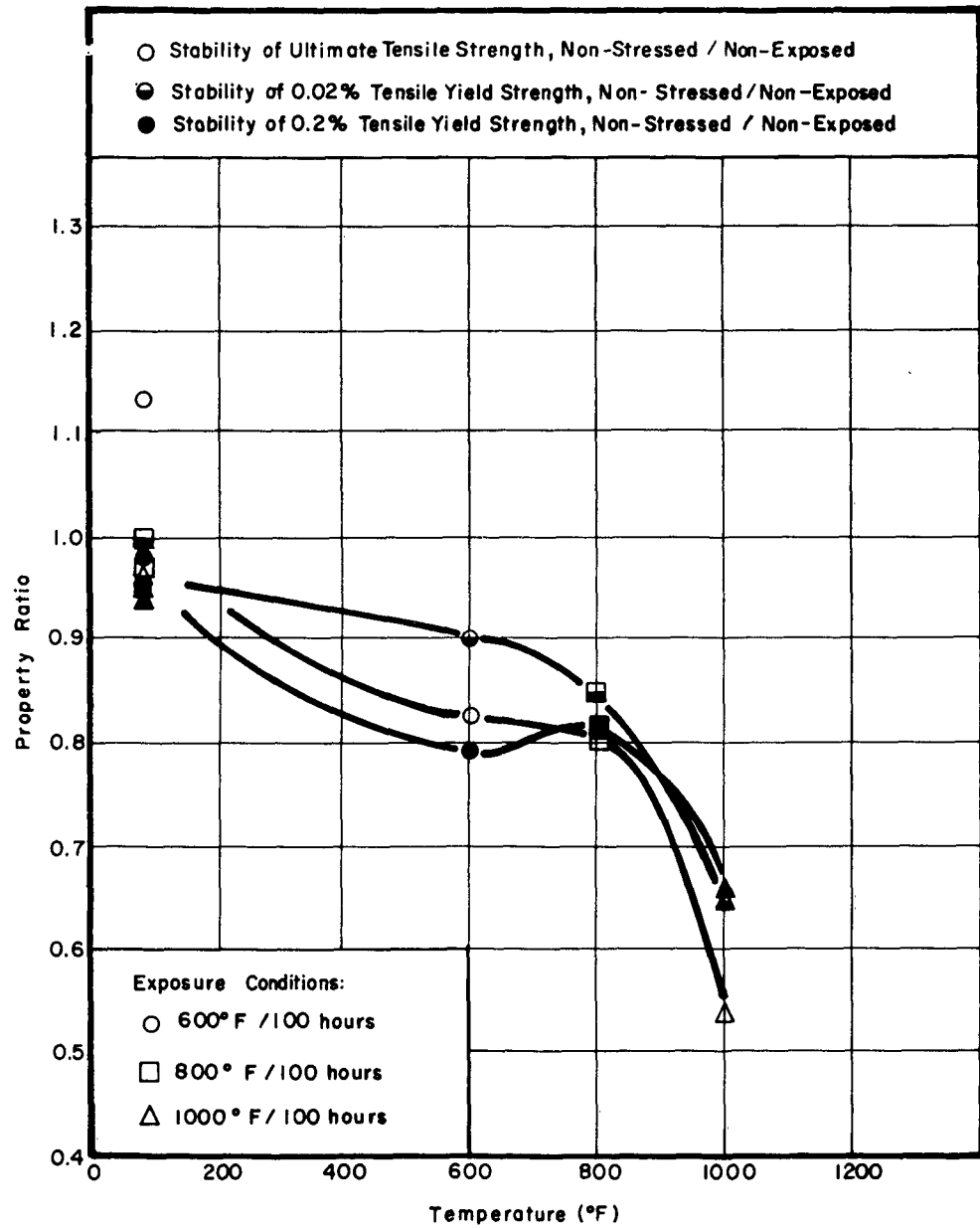

Figure 40. Effect of Exposure Time and Temperature Versus Non-Stressed Tensile Stability/Tensile Properties of Non-Exposed Vasco Jet-1000

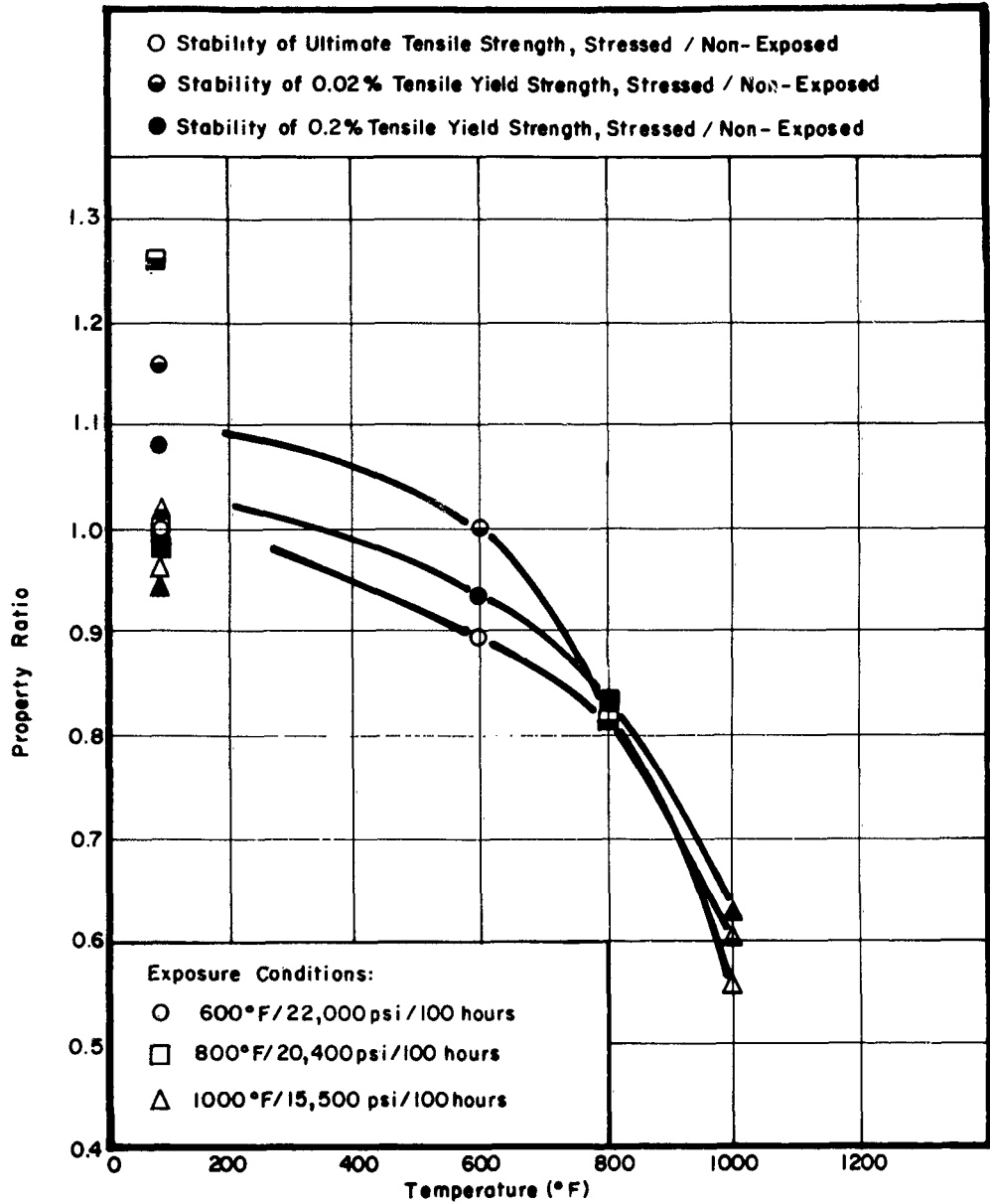

Figure 41. Effect of Exposure Time and Temperature Versus Stressed Tensile Stability/Tensile Properties of Non-Exposed Potomac A

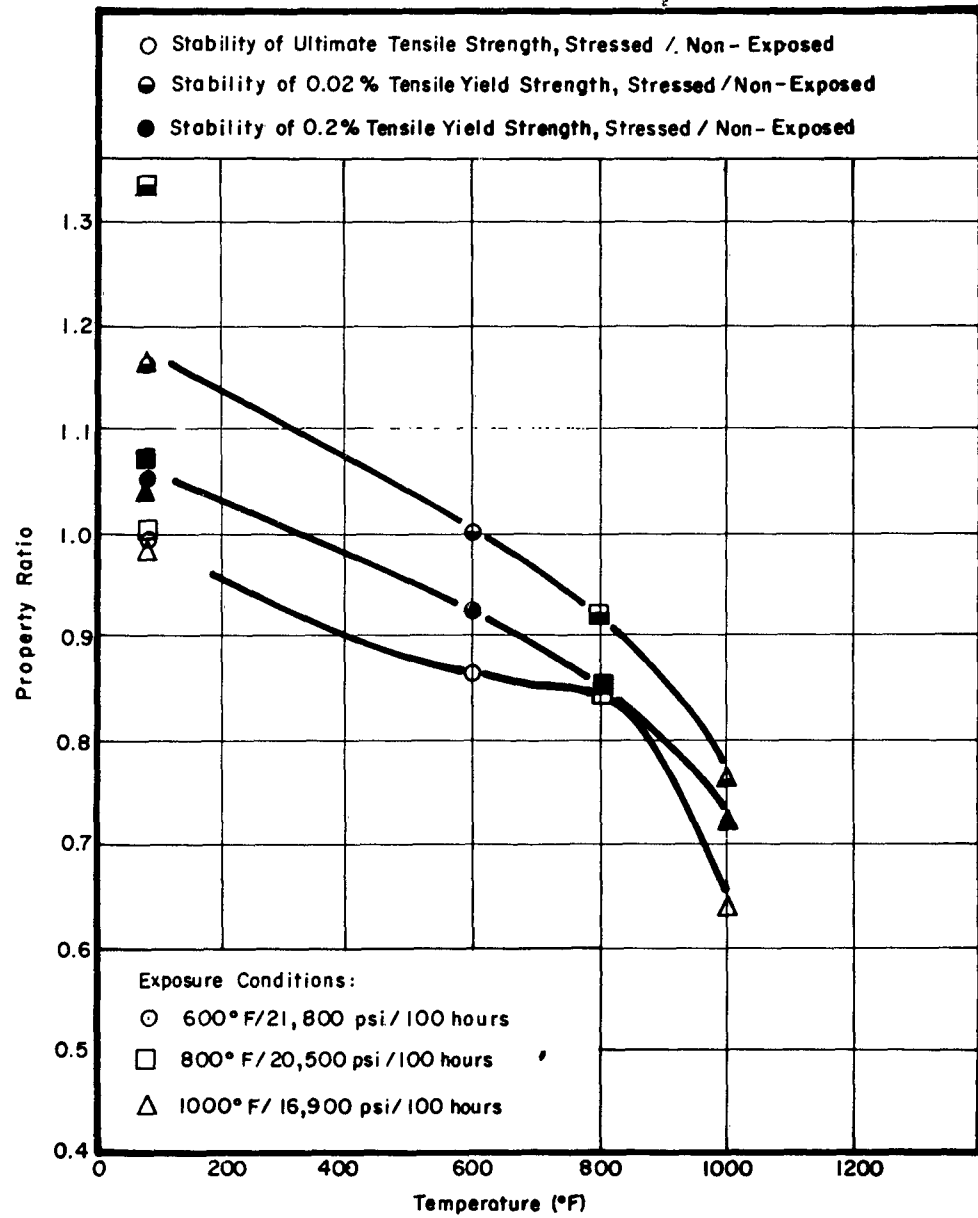

Figure 42. Effect of Exposure Time and Temperature Versus Stressed Tensile Stability/Tensile Properties of Non-Exposed Potomac M

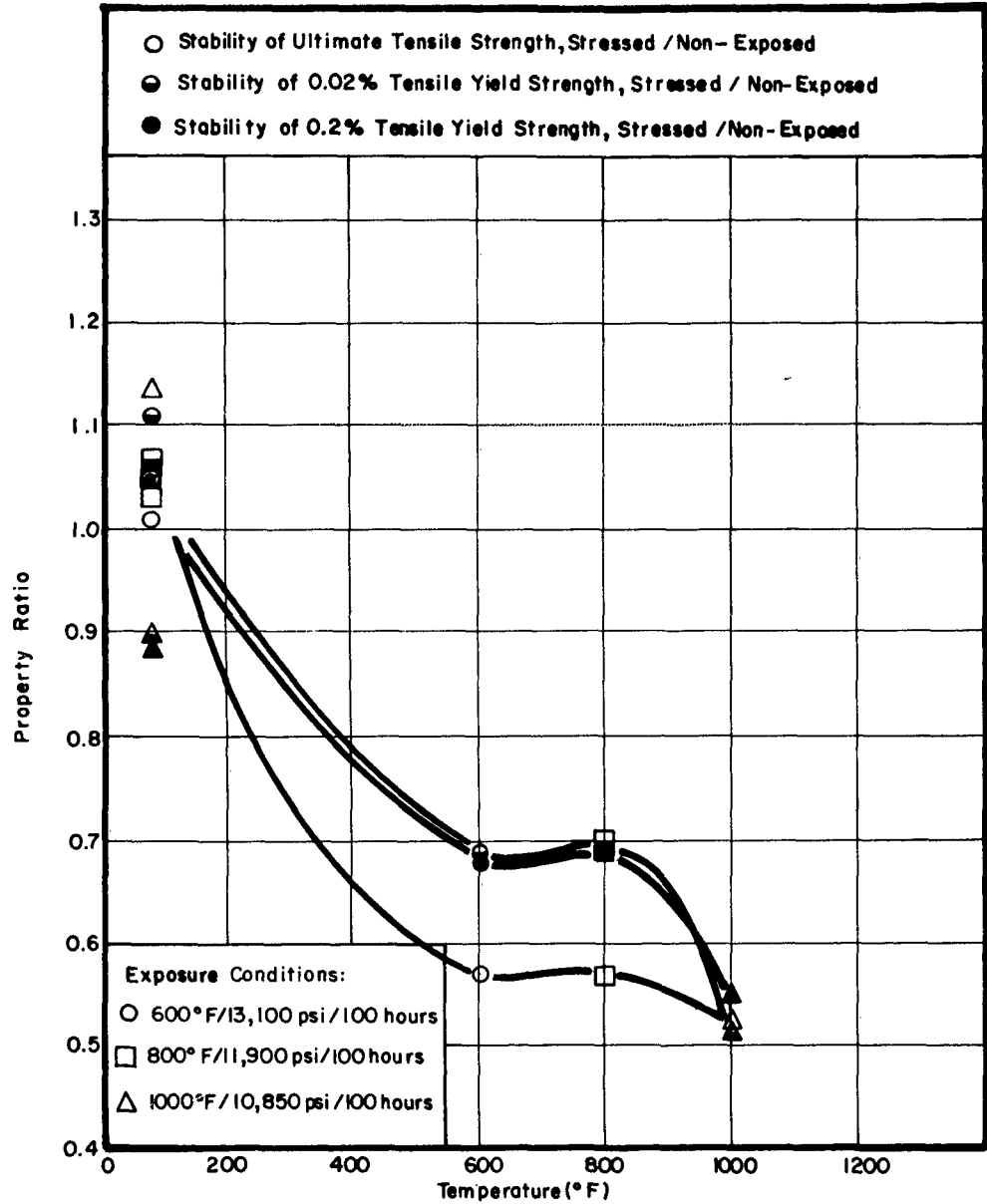

Figure 43. Effect of Exposure Time and Temperature Versus Stressed Tensile Stability/Tensile Properties of Non-Exposed AM-350

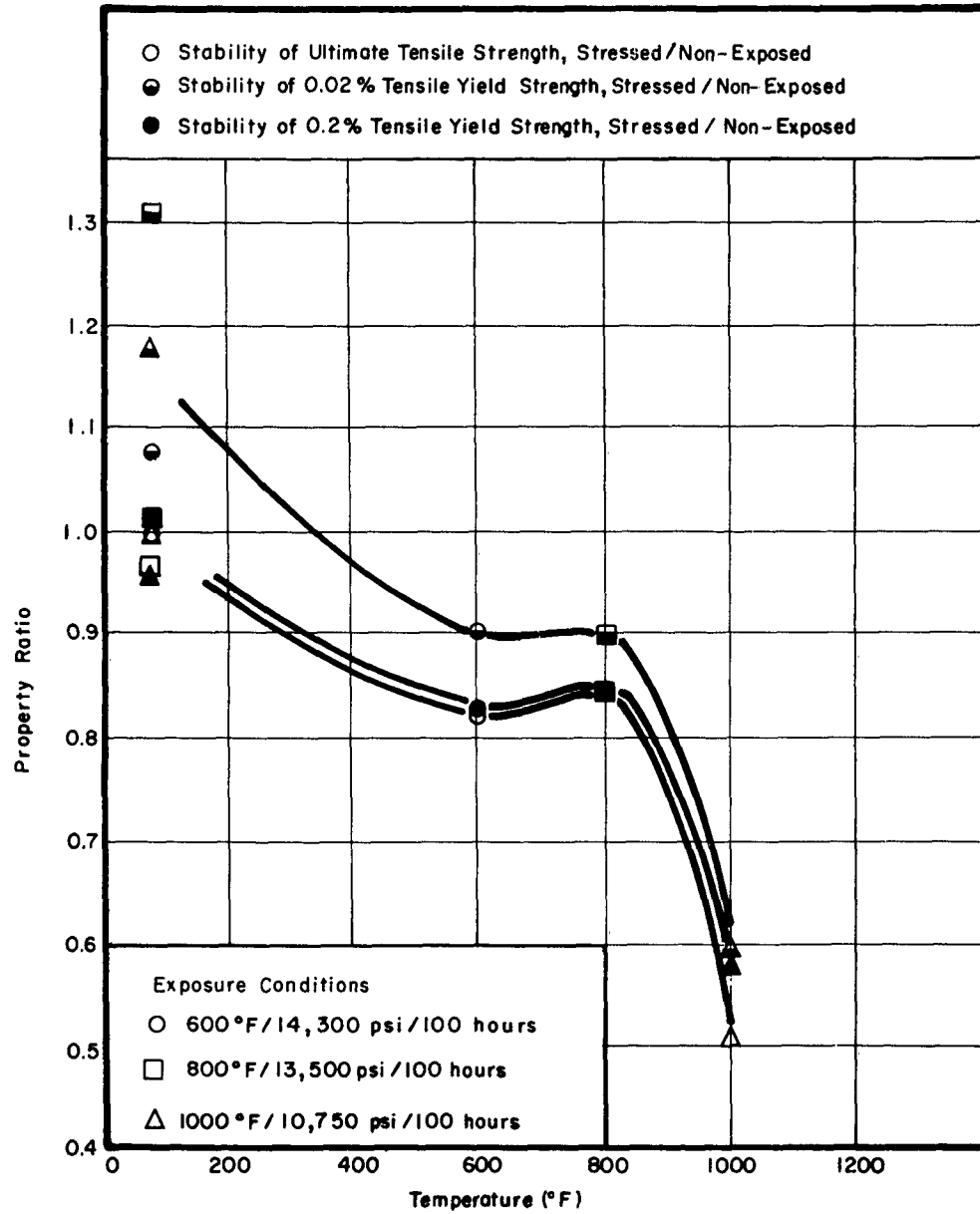

Figure 44. Effect of Exposure Time and Temperature Versus Stressed Tensile Stability/Tensile Properties of Non-Exposed Vasco Jet-1000

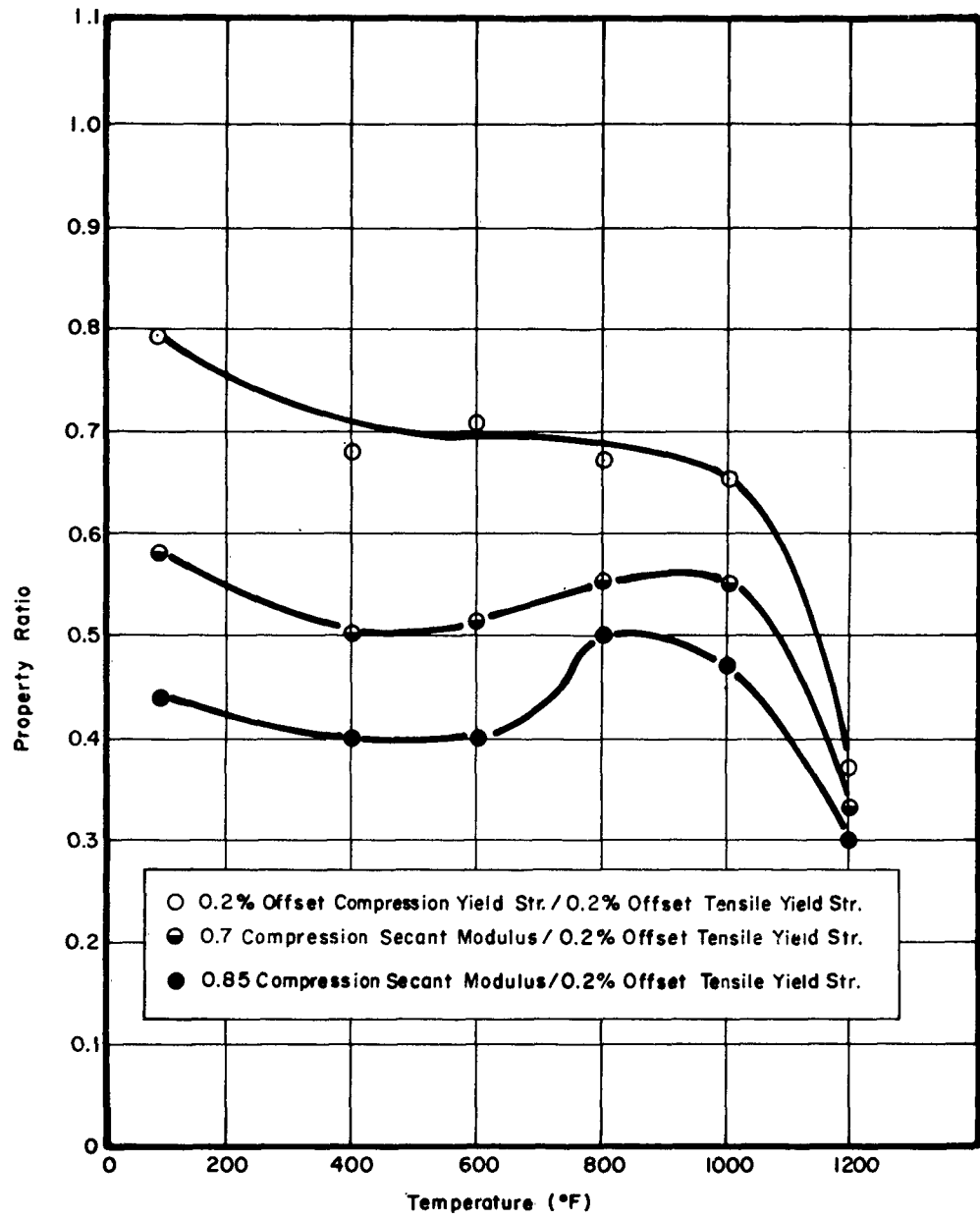

Figure 45. Effect of Temperature Versus the Compressive Properties/Tensile Properties of Potomac A

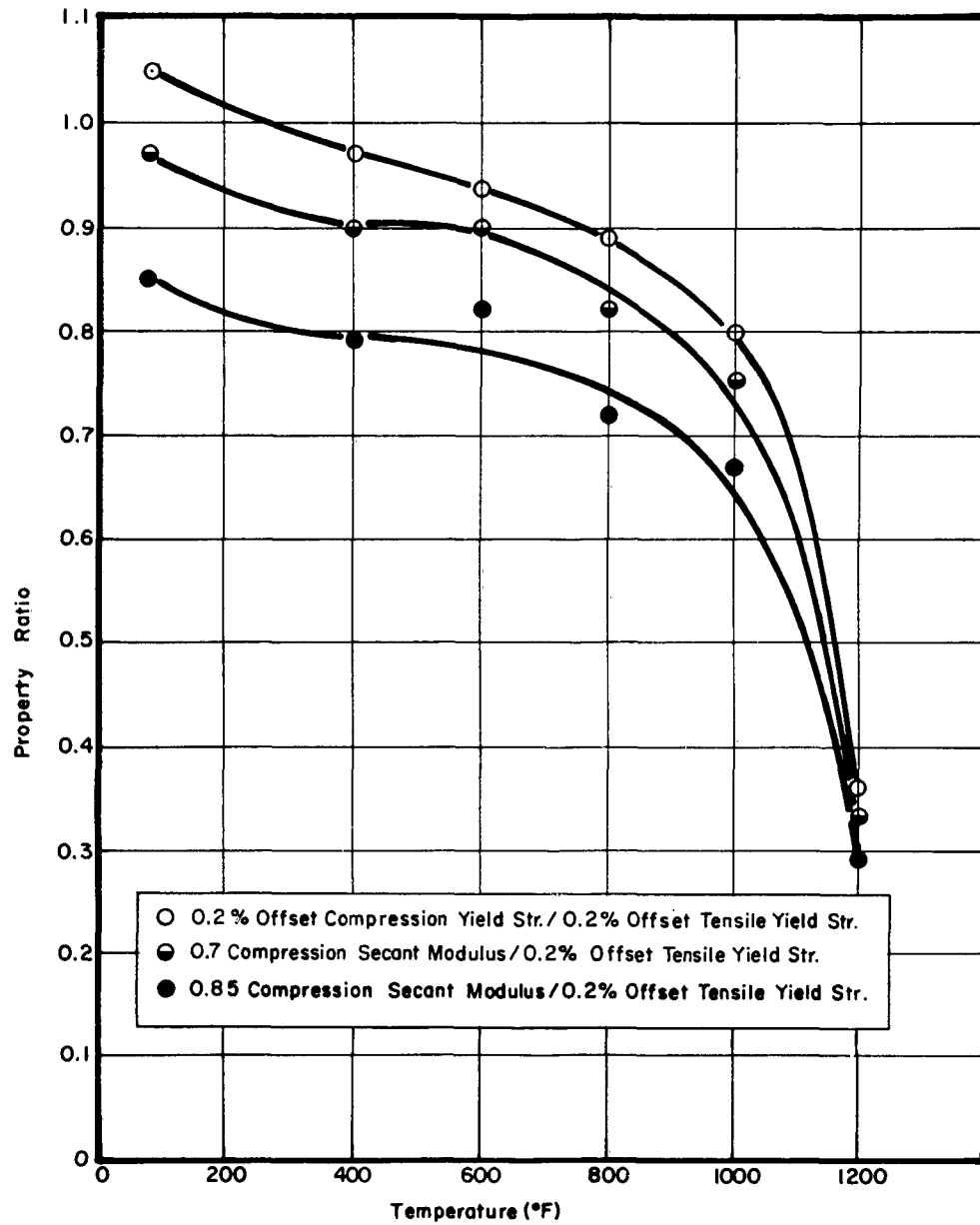

Figure 46. Effect of Temperature Versus the Compressive Properties/Tensile Properties of Potomac M

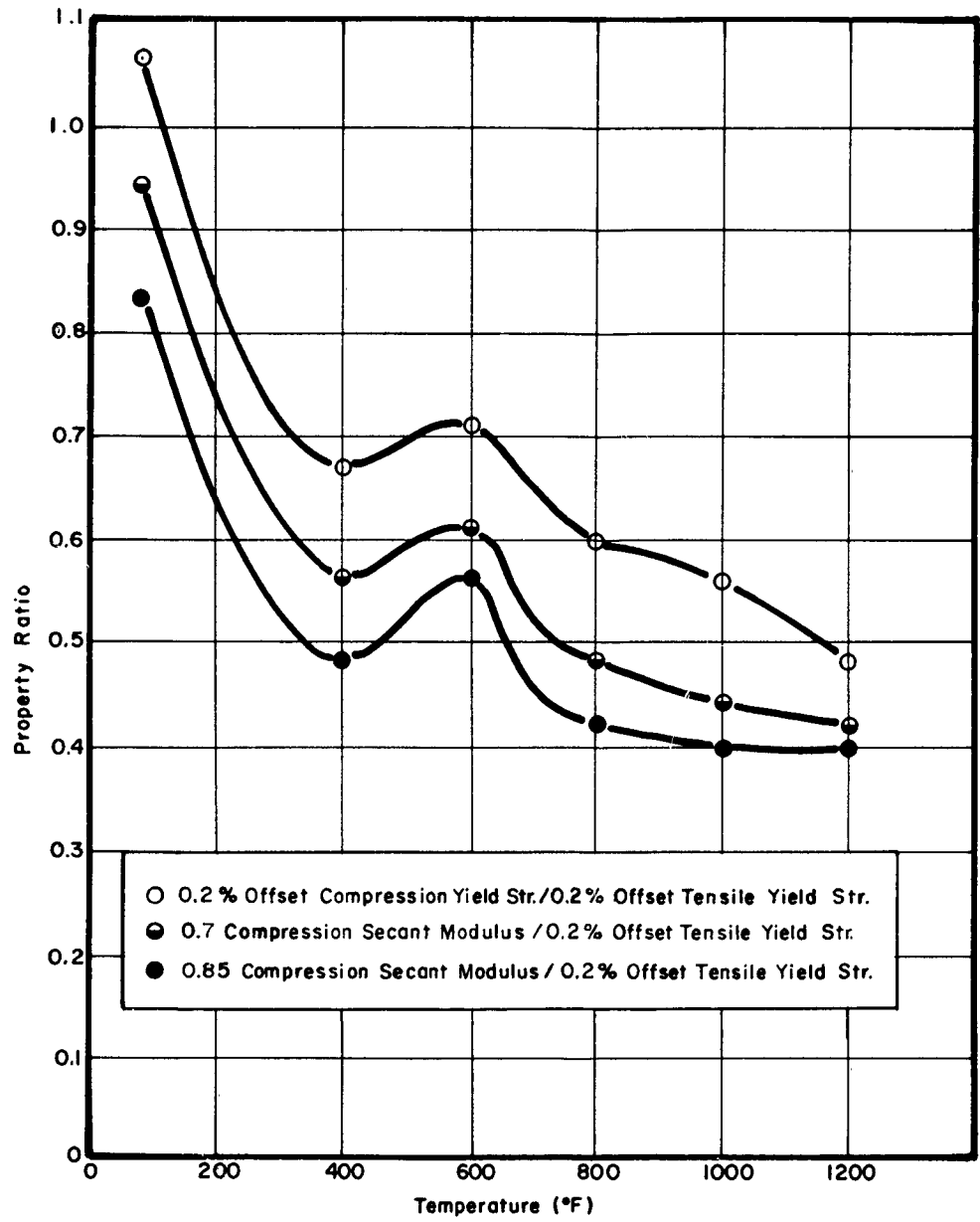

Figure 47. Effect of Temperature Versus the Compressive Properties/Tensile Properties of AM-350

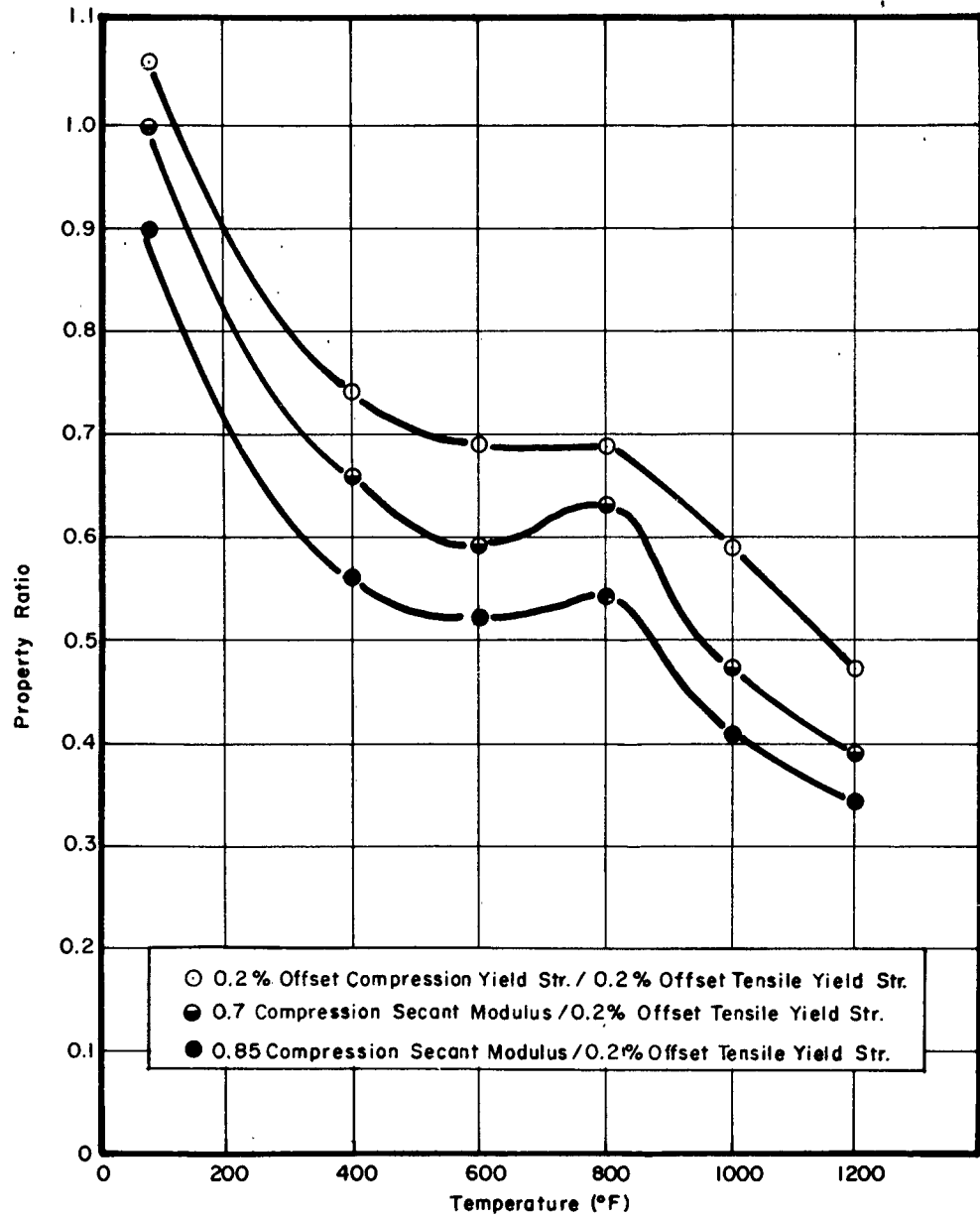

Figure 48. Effect of Temperature Versus the Compressive Properties/Tensile Properties of Vasco Jet-1000

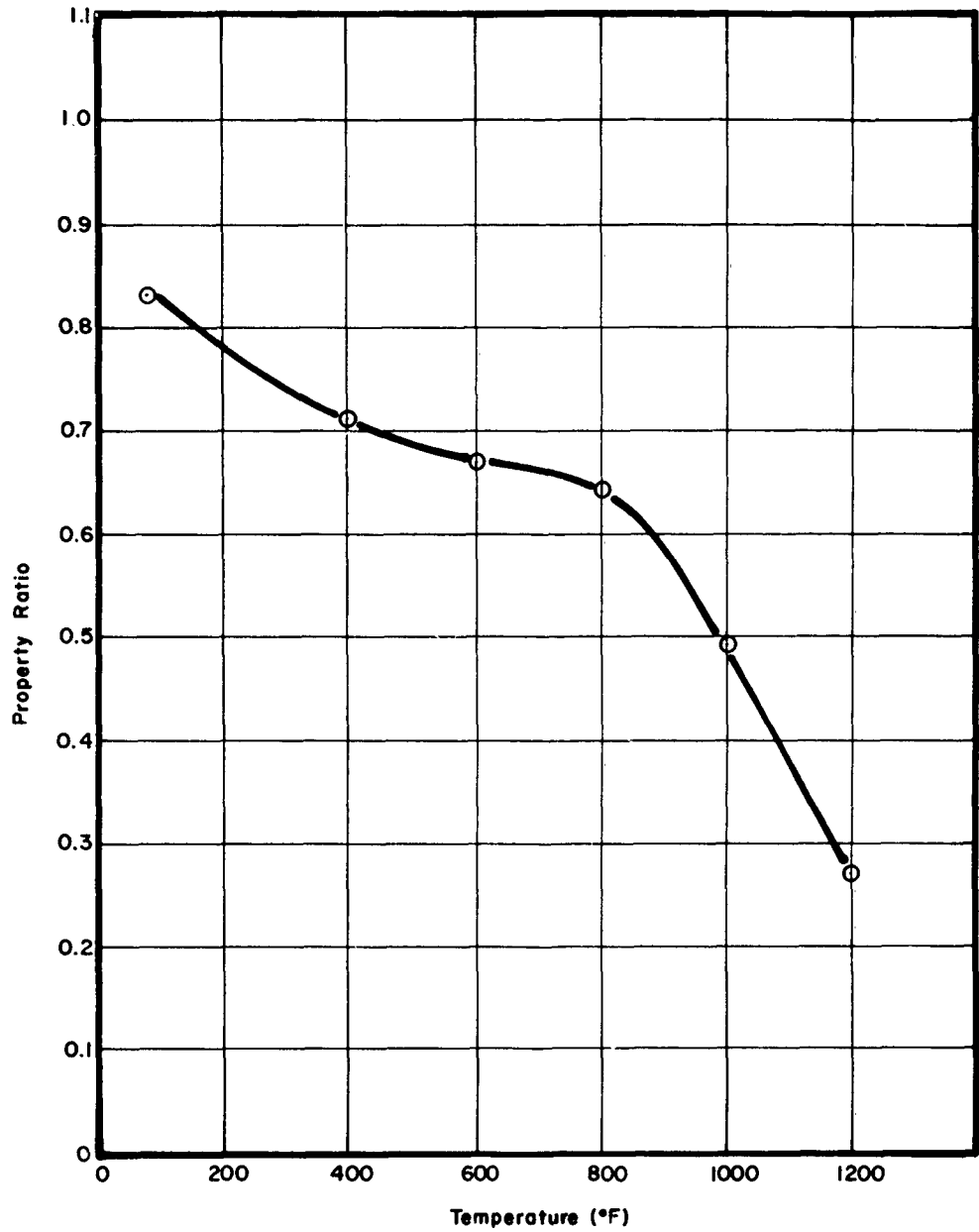

Figure 49. Effect of Temperature Versus the Sheet Shear Strength/Ultimate Tensile Strength of Potomac A

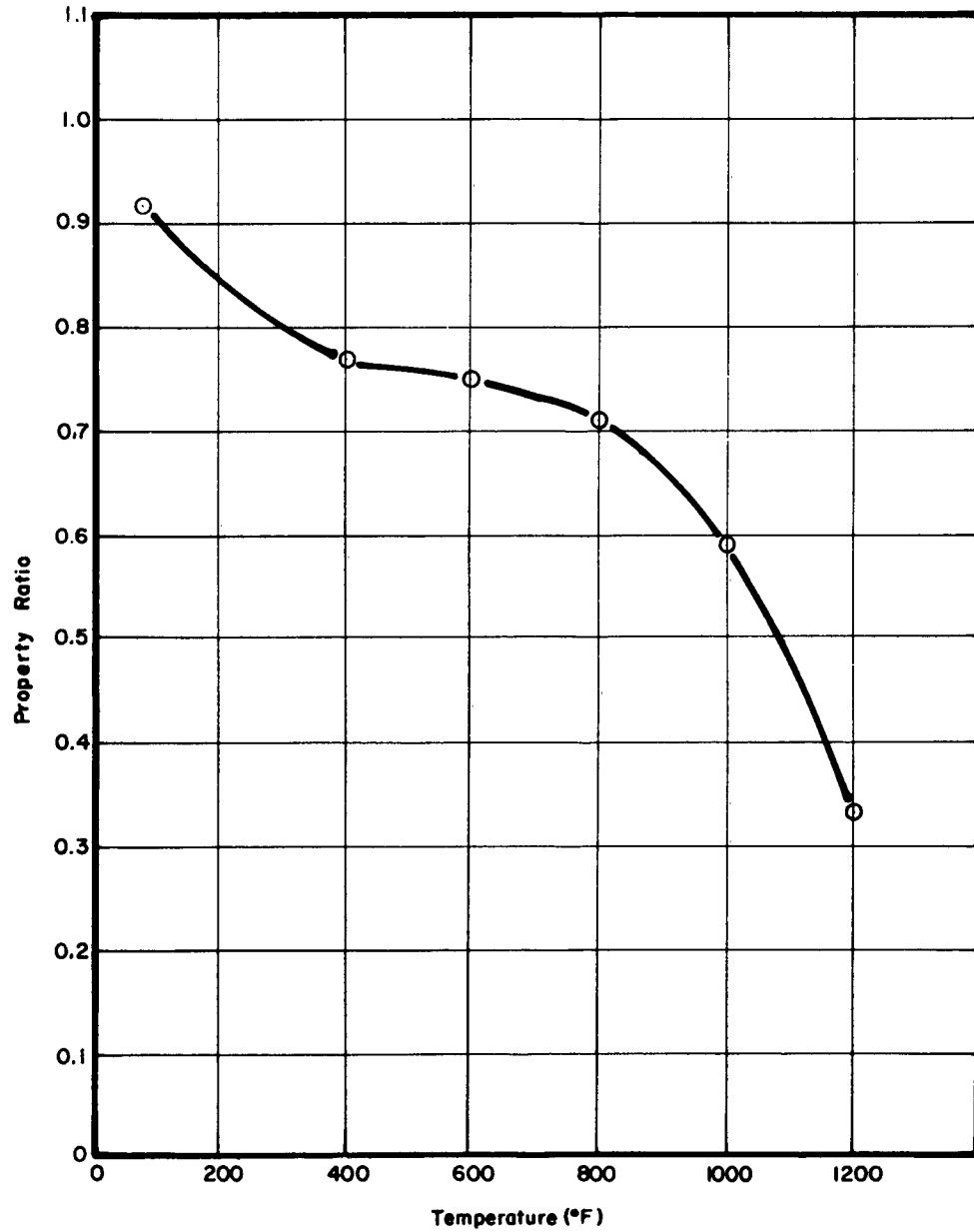

Figure 50. Effect of Temperature Versus the Sheet Shear Strength/Ultimate Tensile Strength of Potomac M

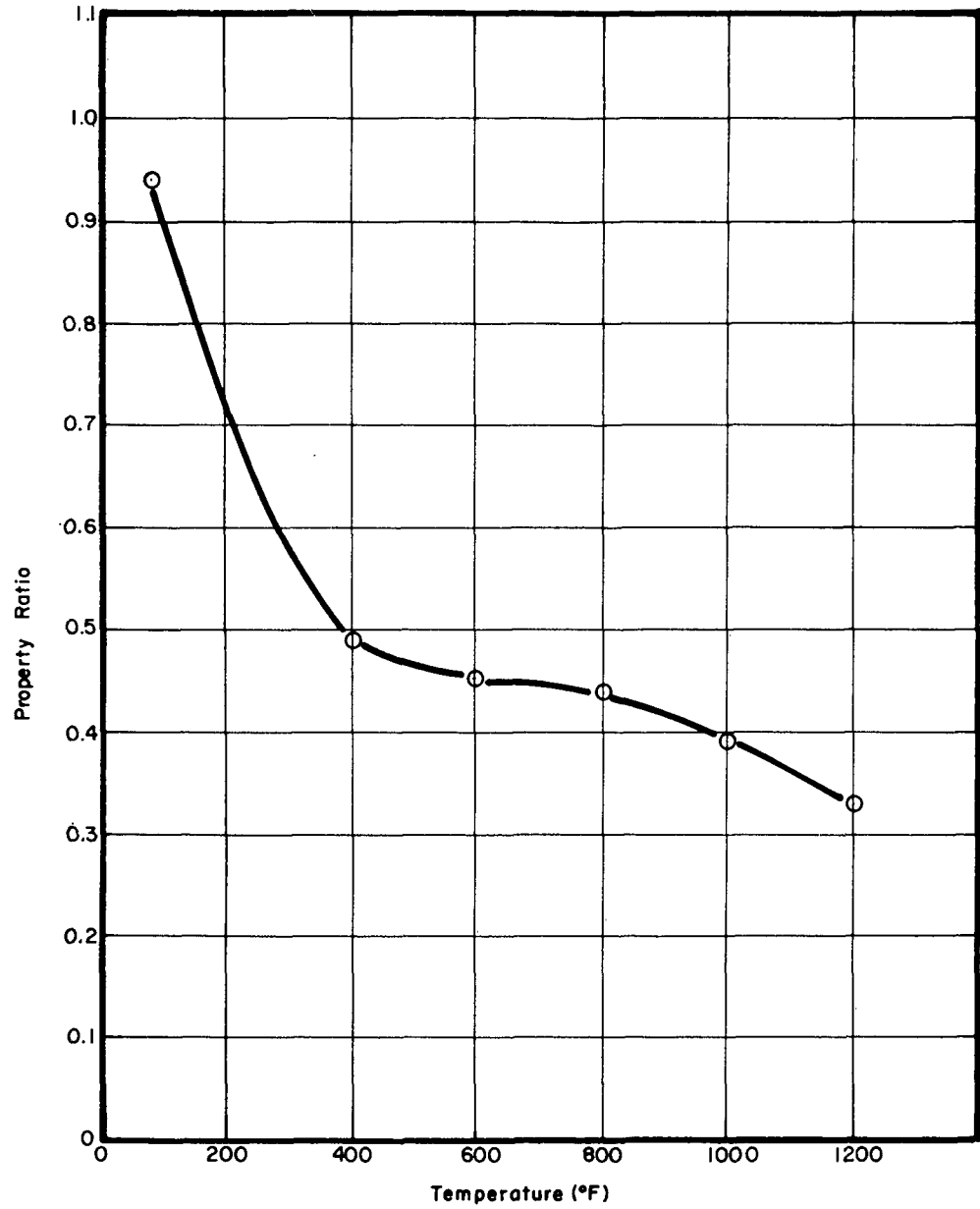

Figure 51. Effect of Temperature Versus the Sheet Shear Strength/Ultimate Tensile Strength of AM-350

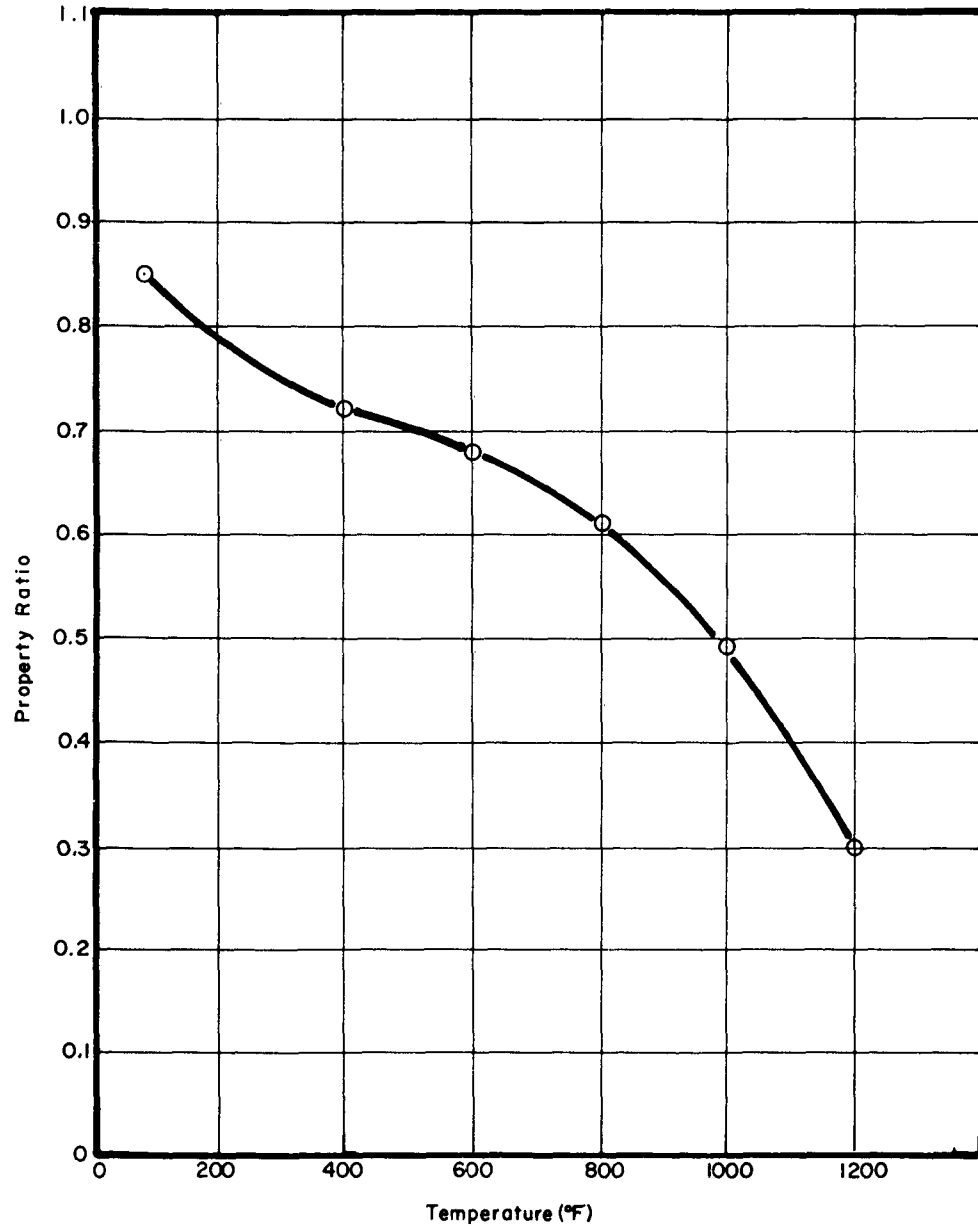

Figure 52. Effect of Temperature Versus the Sheet Shear Strength/Ultimate Tensile Strength of Vasco Jet-1000

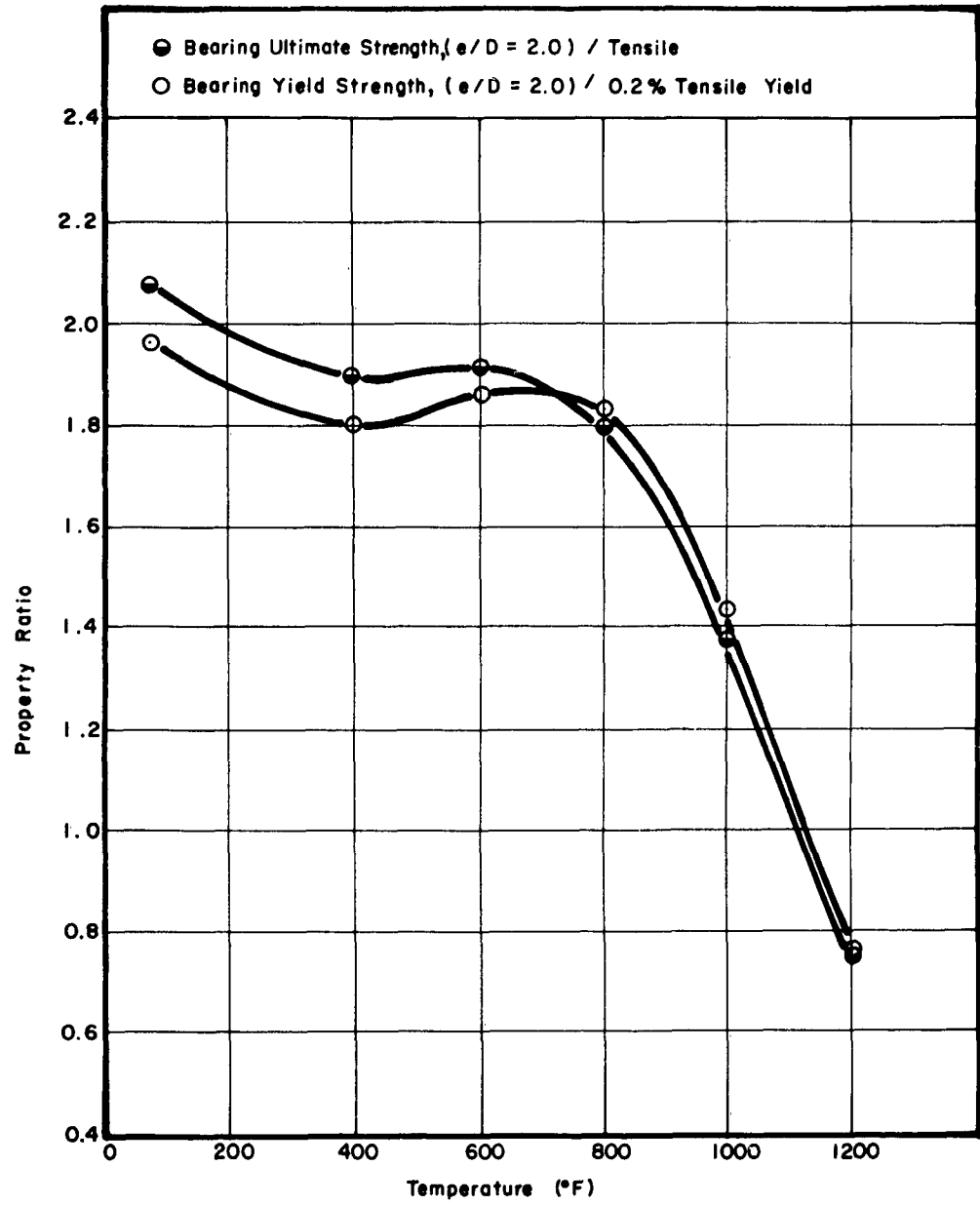

Figure 53. Effect of Temperature Versus the Bearing Properties/Tensile Properties of Potomac A, e/D = 2.0

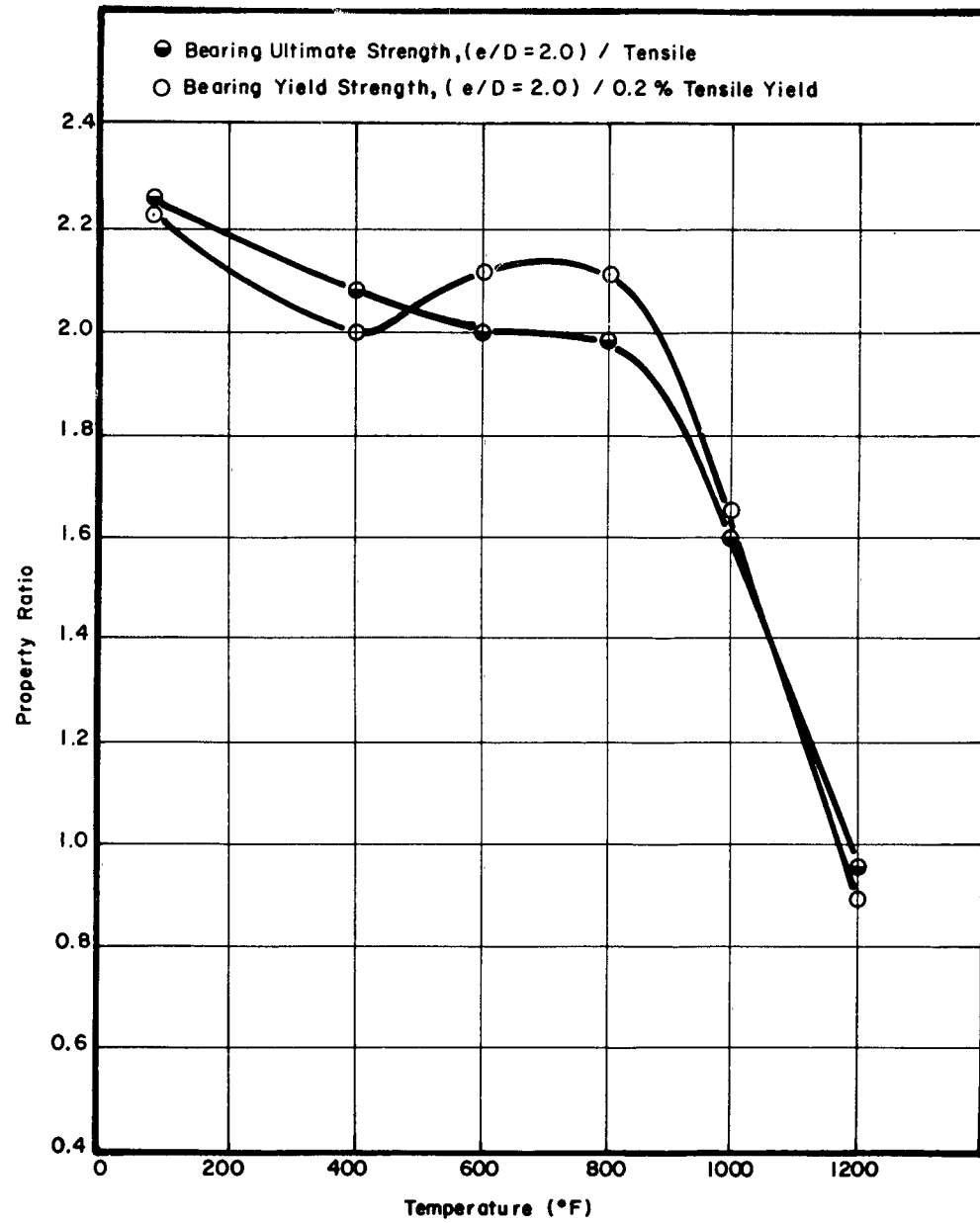

Figure 54. Effect of Temperature Versus the Bearing Properties/Tensile Properties of Potomac M,  $e/D = 2.0$

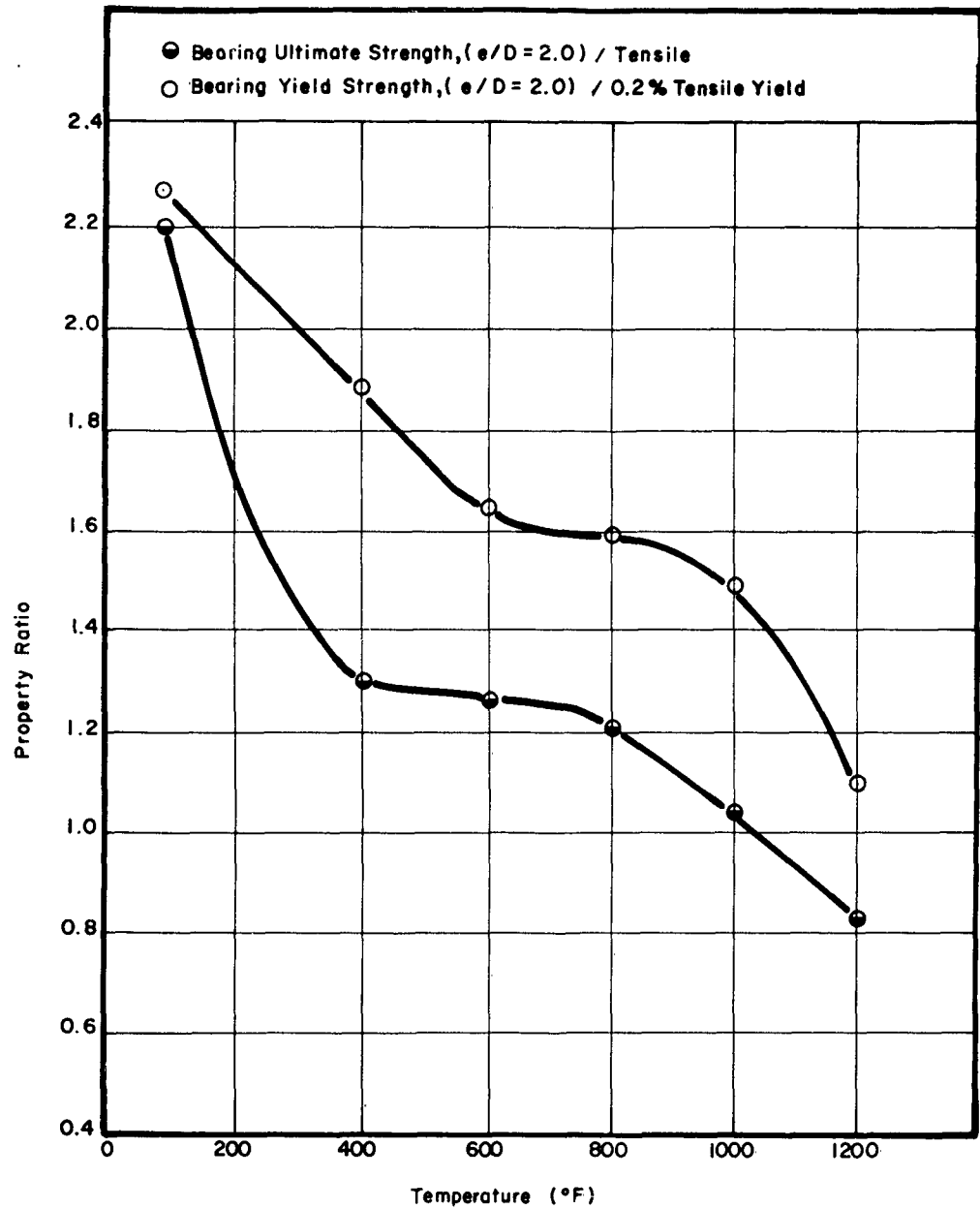

Figure 55. Effect of Temperature Versus the Bearing Properties/Tensile Properties of AM-350, e/D = 2.0

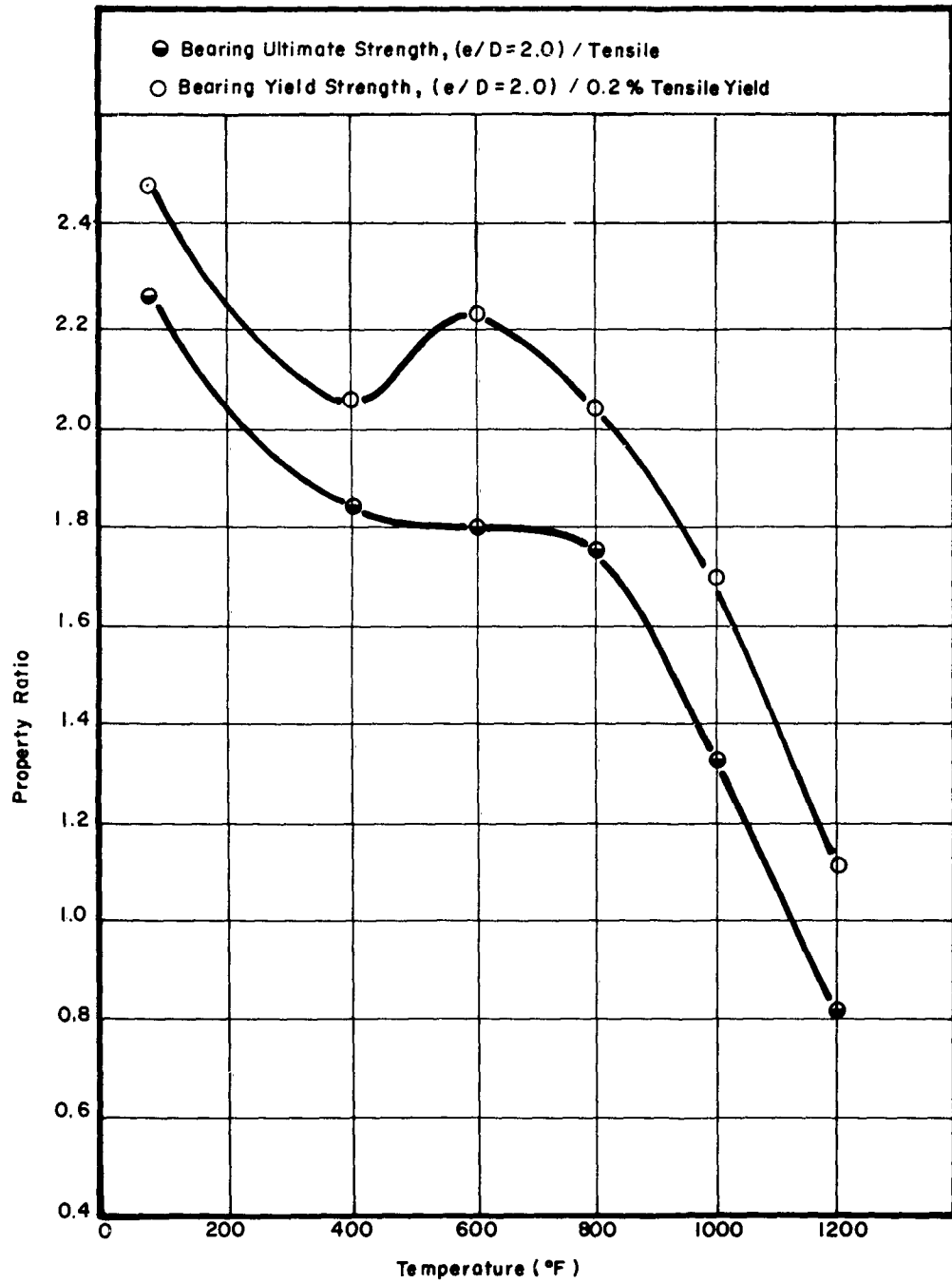

Figure 56. Effect of Temperature Versus the Bearing Properties/Tensile Properties of Vasco Jet-1000, e/D = 2.0

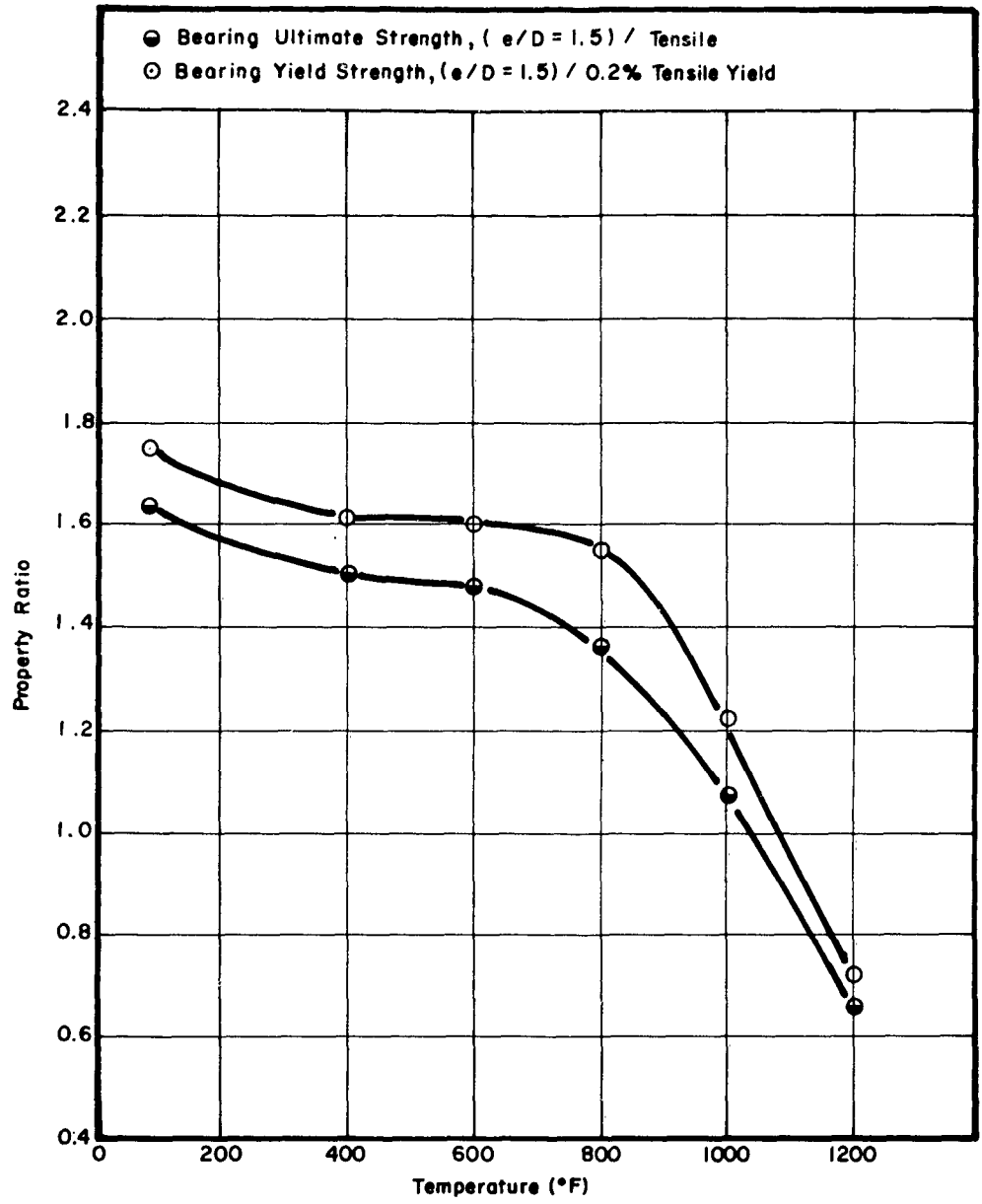

Figure 57. Effect of Temperature Versus the Bearing Properties/Tensile Properties of Potomac A,  $e/D = 1.5$

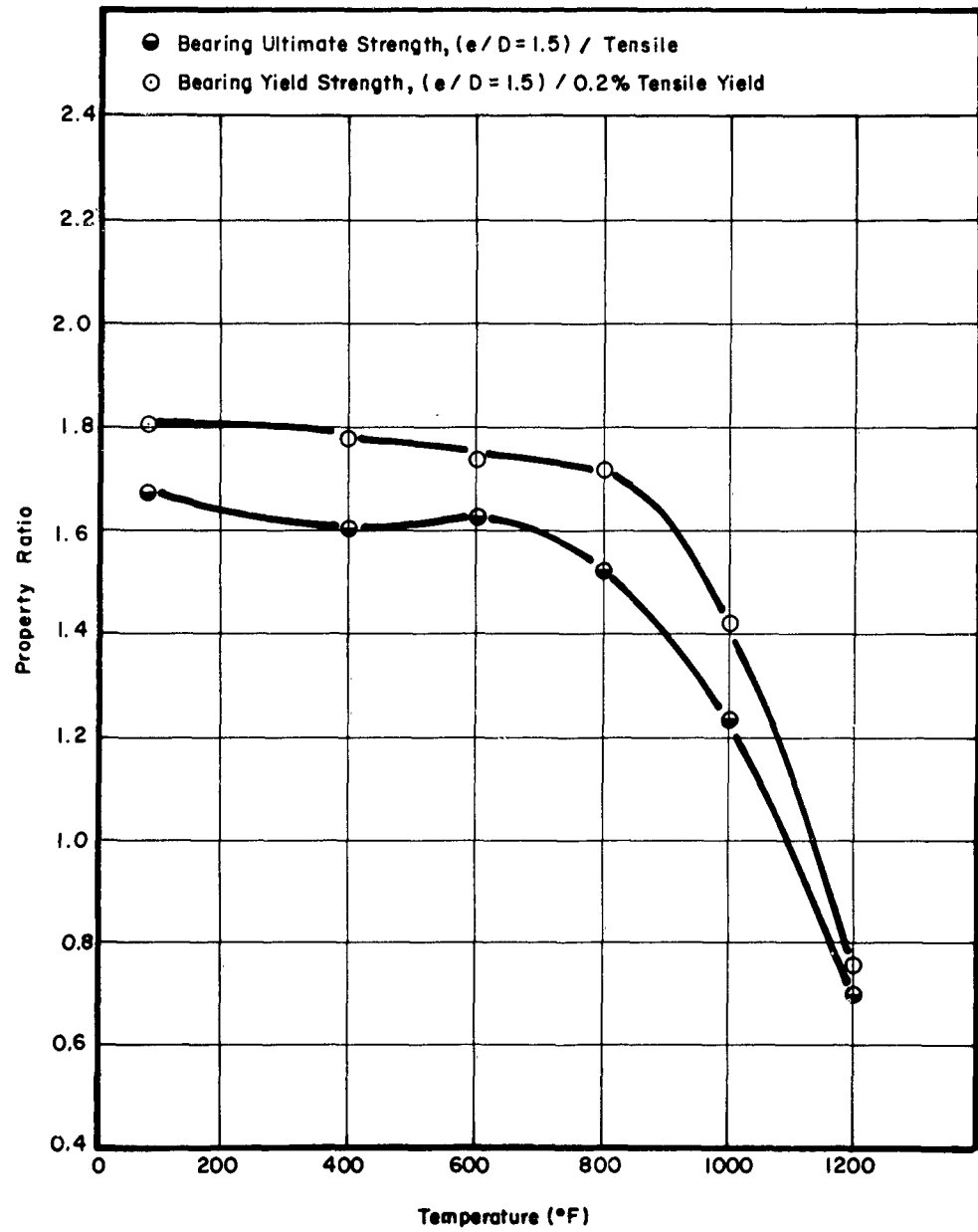

Figure 58. Effect of Temperature Versus the Bearing Properties/Tensile Properties of Potomac M,  $e/D = 1.5$

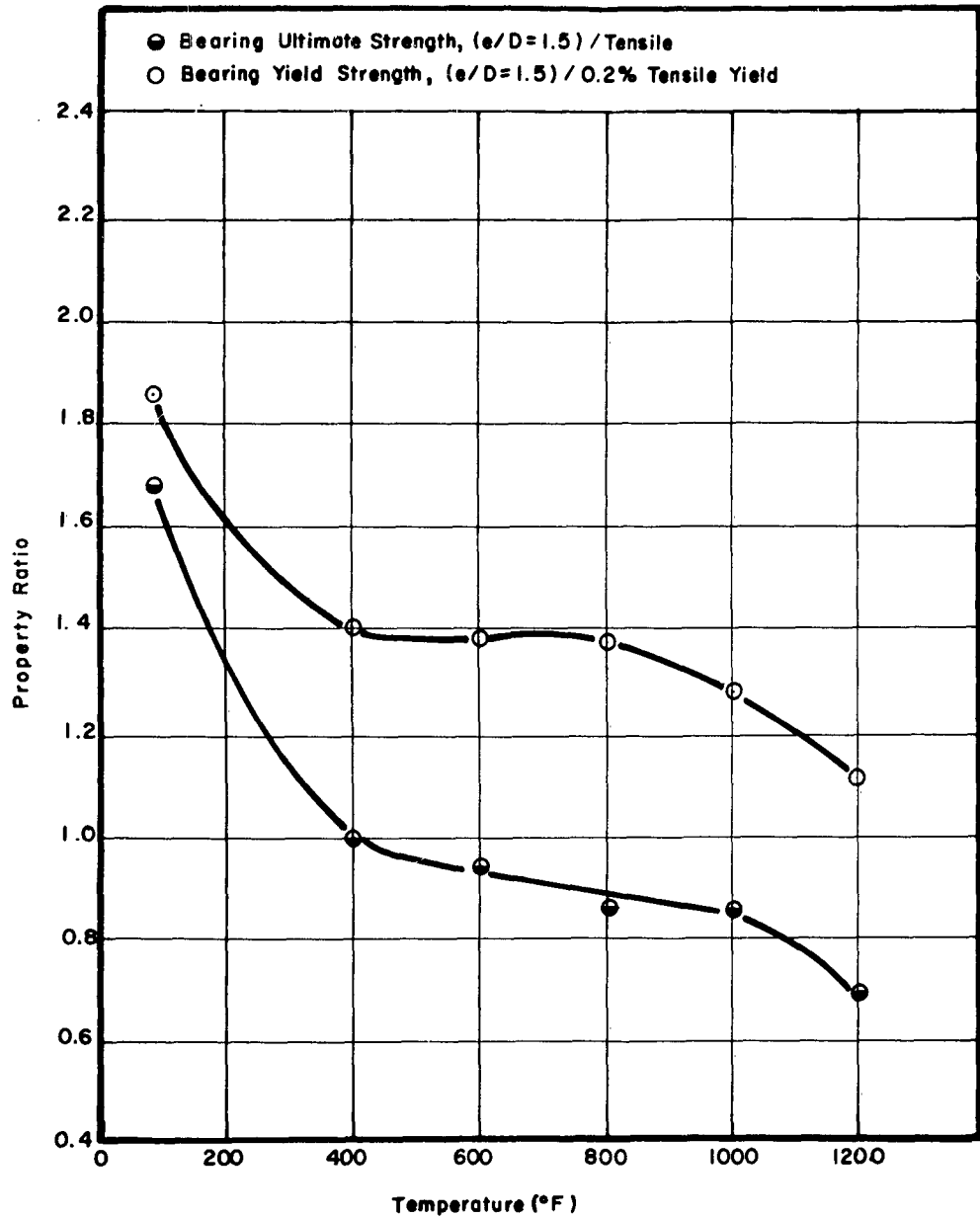

Figure 59. Effect of Temperature Versus the Bearing Properties/Tensile Properties of AM-350,  $e/D = 1.5$

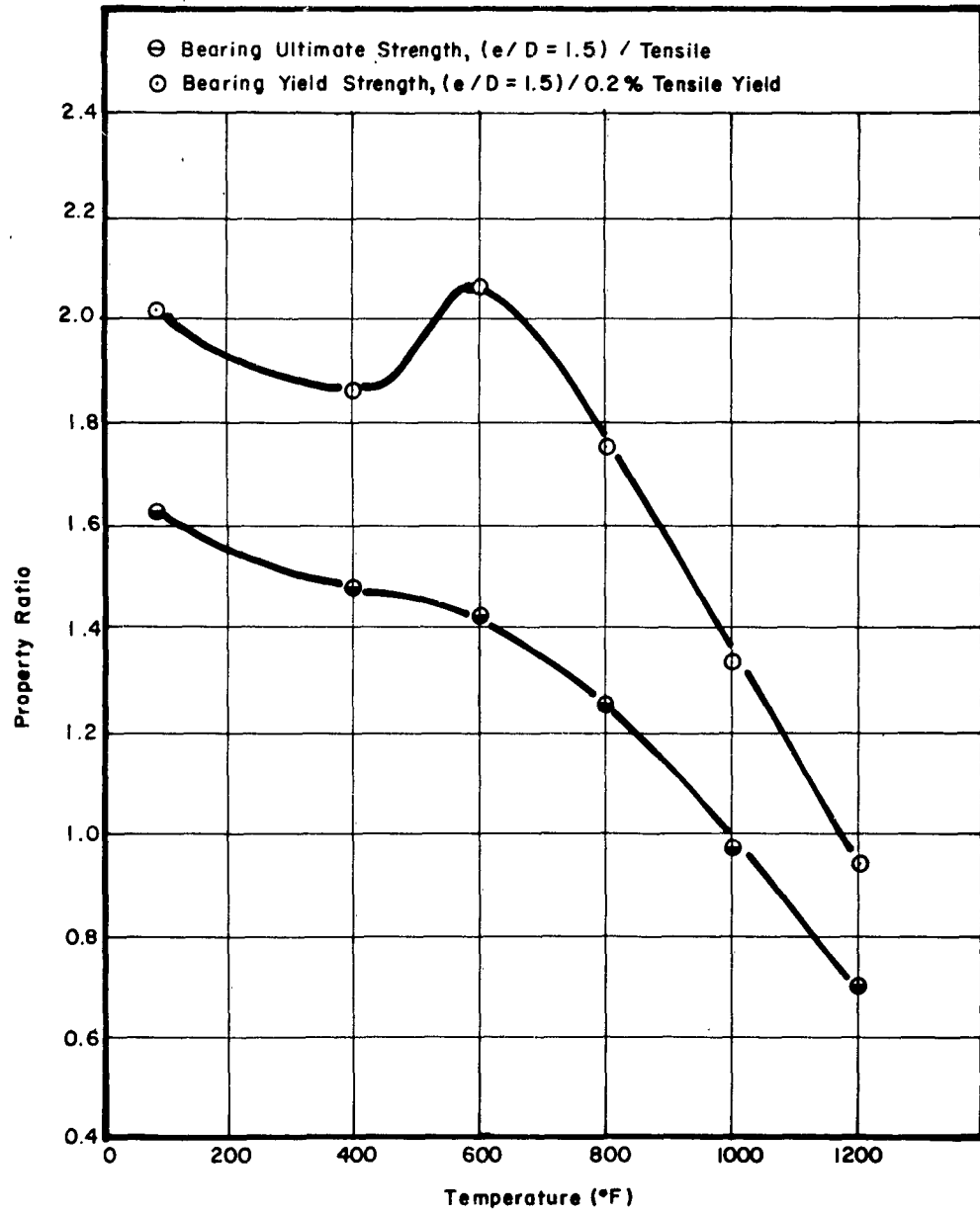

Figure 60. Effect of Temperature Versus the Bearing Properties/Tensile Properties of Vasco Jet-1000, e/D = 1.5

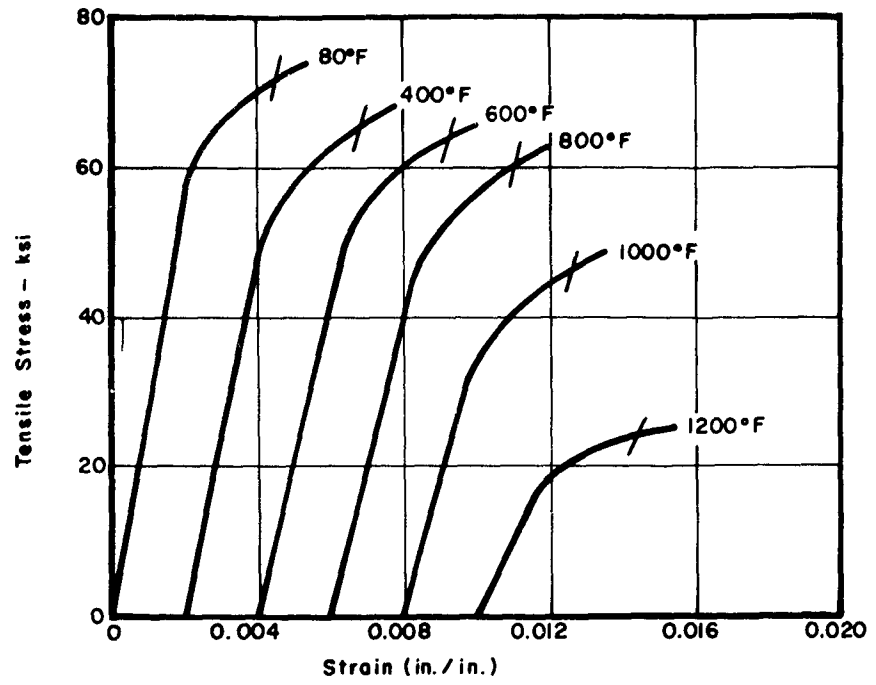

Figure 61. Tensile Stress-Strain Curves of Potomac A

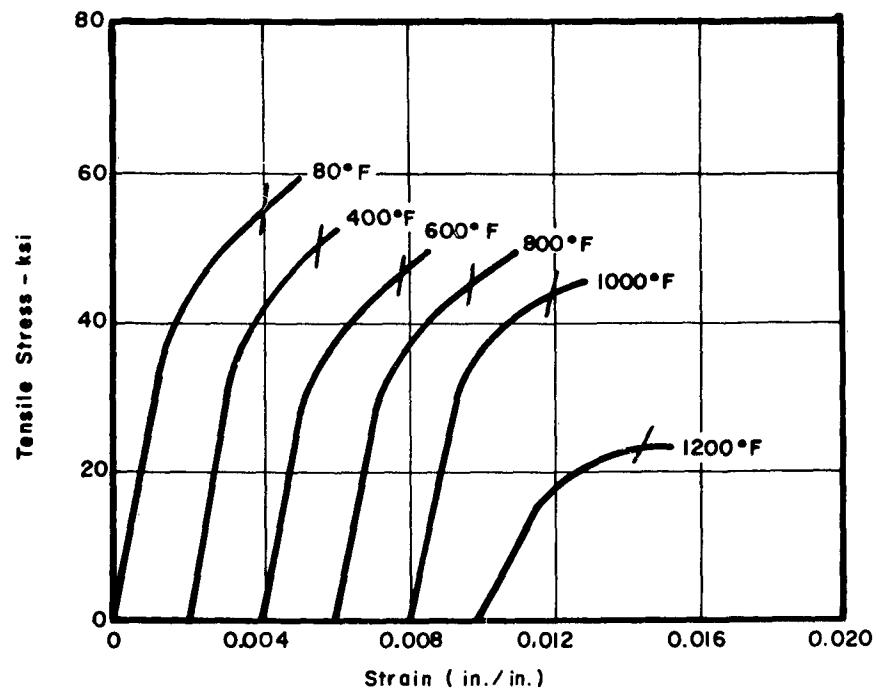

Figure 62. Compression Stress-Strain Curves of Potomac A

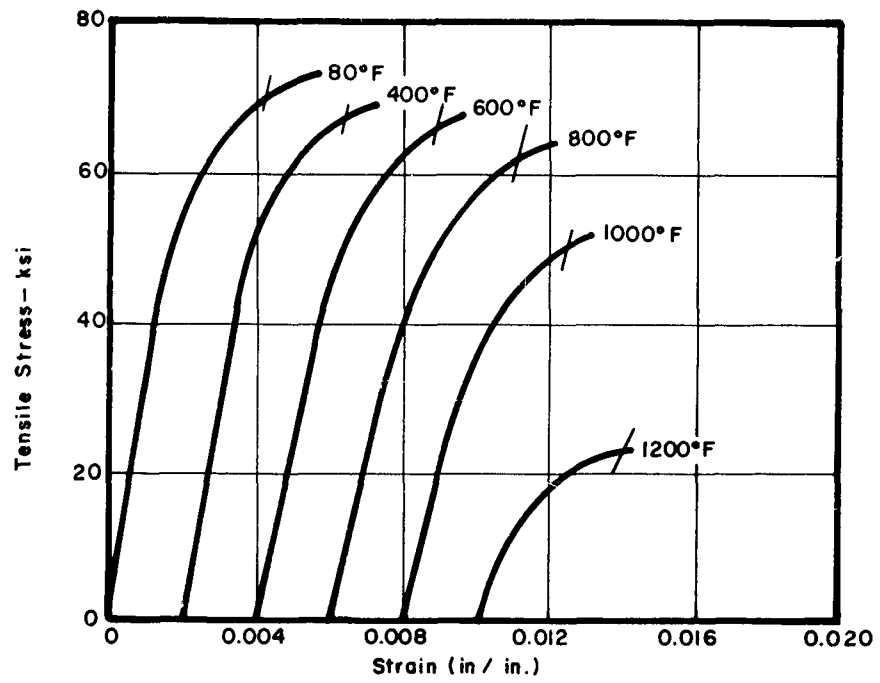

Figure 63. Tensile Stress-Strain Curves of Potomac M

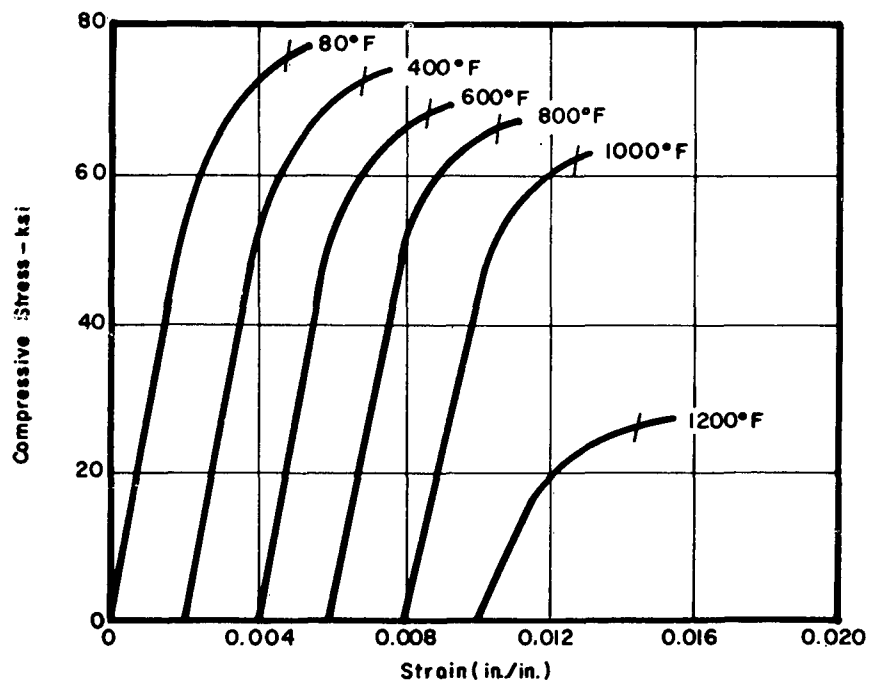

Figure 64. Compression Stress-Strain Curves of Potomac M

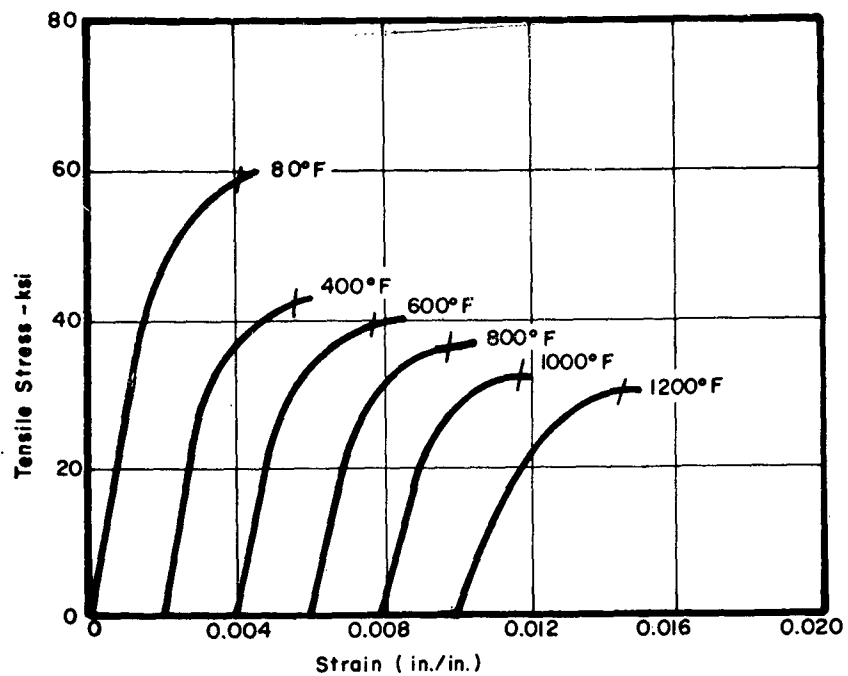

Figure 65. Tensile Stress-Strain Curves of AM-350

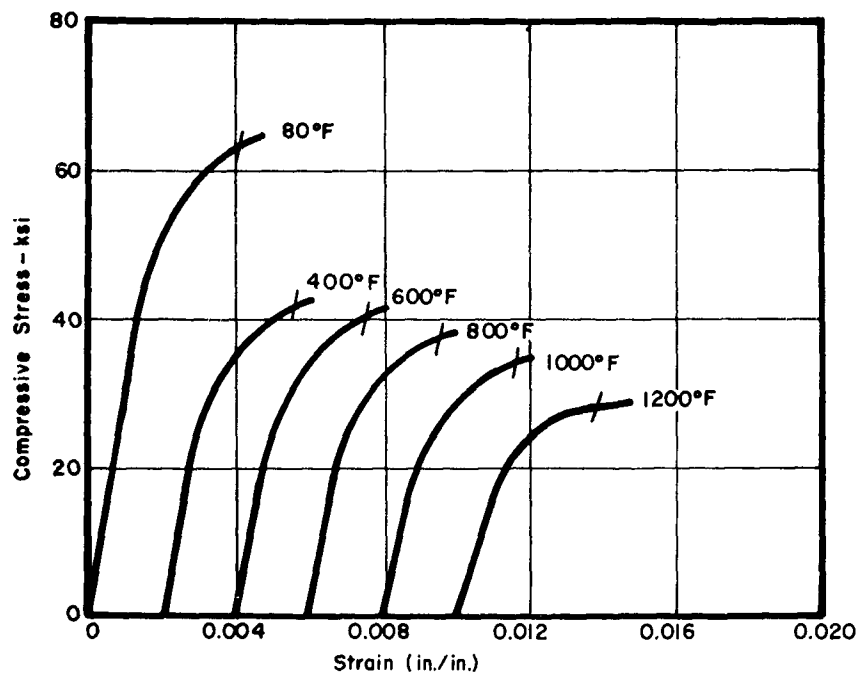

Figure 66. Compression Stress-Strain Curves of AM-350

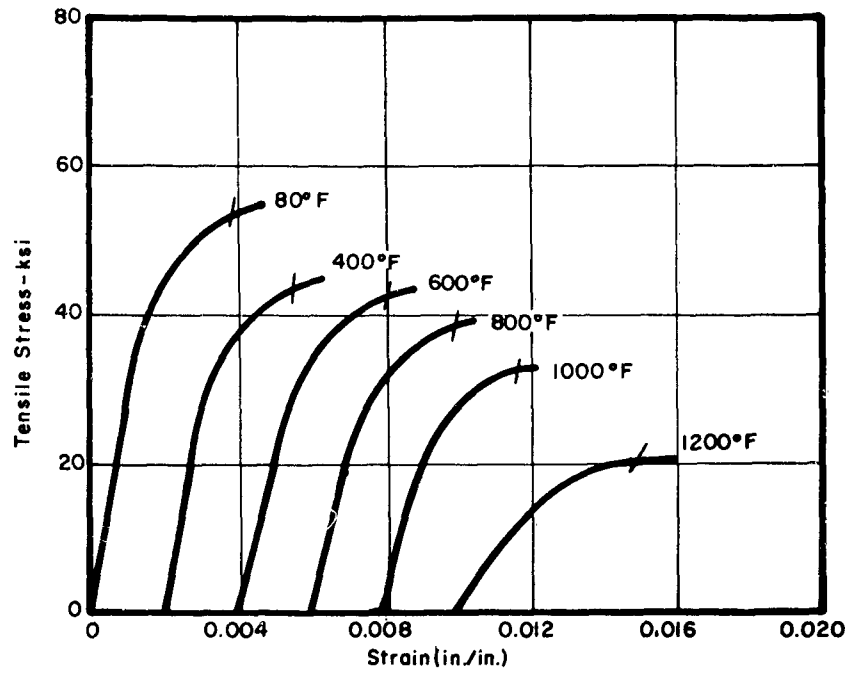

Figure 67. Tensile Stress-Strain Curves of Vasco Jet-1000

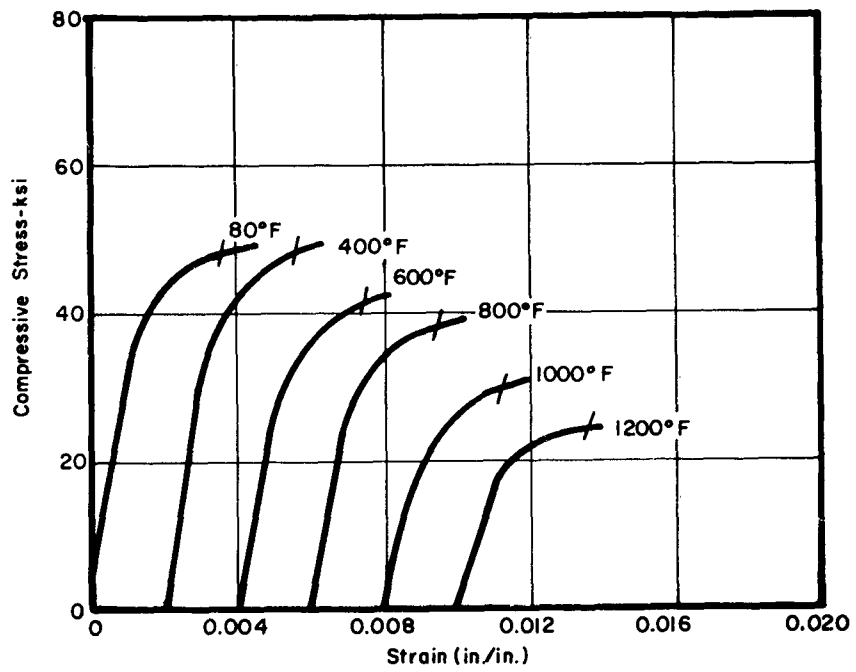

Figure 68. Compression Stress-Strain Curves of Vasco Jet-1000

Aeronautical Systems Division, Dir./Materials & Processes, Metals & Ceramics Lab, Wright-Patterson AFB, Ohio.  
Rpt No. ASD-TDR-63-116. MECHANICAL PROPERTIES OF AM-350, POTOMAC A, POTOMAC M, AND VASCO JET-1000 STEEL ALLOYS IN THE ANNEALED CONDITION. Final report, May 63, 102p.. incl illus. and tables.

Unclassified Report

Mechanical properties of three hot-worked steels and one precipitation-hardening stainless steel were obtained. Properties obtained were tensile, compression, sheet single shear, bearing, and 105-degree-angle bend tests.

( over )

1. Steel Alloys  
I. AFSC Proj 7351, Task 735106  
II. Henning, Robert G., Capt, USAF, and Brisbane, Alton W.  
III. Aval fr OTS  
IV. In ASTIA collection

Aeronautical Systems Division, Dir./Materials & Processes, Metals & Ceramics Lab, Wright-Patterson AFB, Ohio.  
Rpt No. ASD-TDR-63-116. MECHANICAL PROPERTIES OF AM-350, POTOMAC A, POTOMAC M, AND VASCO JET-1000 STEEL ALLOYS IN THE ANNEALED CONDITION. Final report, May 63, 102p.. incl illus. and tables.

Unclassified Report

Mechanical properties of three hot-worked steels and one precipitation-hardening stainless steel were obtained. Properties obtained were tensile, compression, sheet single shear, bearing, and 105-degree-angle bend tests.

( over )

Tests were conducted at temperatures of 80°, 400°, 600°, 800°, 1000°, and 1200°F. Stressed and non-stressed exposure tests were conducted only at 600°, 800°, and 1000°F. All properties were obtained from the longitudinal direction of the material except three tensile specimens from each material in the transverse direction, which were tested only at 80°F. Data obtained are presented graphically. Metallurgical histories and chemical analyses are also included.

Tests were conducted at temperatures of 80°, 400°, 600°, 800°, 1000°, and 1200°F. Stressed and non-stressed exposure tests were conducted only at 600°, 800°, and 1000°F. All properties were obtained from the longitudinal direction of the material except three tensile specimens from each material in the transverse direction, which were tested only at 80°F. Data obtained are presented graphically. Metallurgical histories and chemical analyses are also included.