

UNCLASSIFIED

AD 408 794

DEFENSE DOCUMENTATION CENTER

FOR

SCIENTIFIC AND TECHNICAL INFORMATION

CAMERON STATION, ALEXANDRIA, VIRGINIA



UNCLASSIFIED

NOTICE: When government or other drawings, specifications or other data are used for any purpose other than in connection with a definitely related government procurement operation, the U. S. Government thereby incurs no responsibility, nor any obligation whatsoever; and the fact that the Government may have formulated, furnished, or in any way supplied the said drawings, specifications, or other data is not to be regarded by implication or otherwise as in any manner licensing the holder or any other person or corporation, or conveying any rights or permission to manufacture, use or sell any patented invention that may in any way be related thereto.

408 794

63-4-2

**DEVIATION FROM LAMBERTIAN OPTICAL
REFLECTION FOR SEVERAL STANDARD
SURFACE MATERIALS**

CATALOGED BY DDC
AS AD No. 63-4-2

Quarterly Progress Report, Part 2

Contract No. AF 33 (657)-9014

1 October 1962 — 31 December 1962

Prepared by:

Dr. Werner Rambauske

Ronald Hodge

University of Dayton

Research Institute

Dayton 9, Ohio

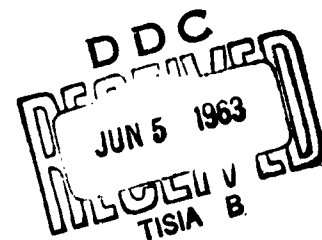

Prepared for:

Aeronautical Systems Division

Air Force Systems Command

Reconnaissance Laboratory

Wright Patterson Air Force Base, Ohio

17.1

**DEVIATION FROM LAMBERTIAN OPTICAL
REFLECTION FOR SEVERAL STANDARD
SURFACE MATERIALS**

**Quarterly Progress Report, Part 2
Contract No. AF 33(657)-9014
1 October 1962 - 31 December 1962**

**Prepared by:
Dr. Werner Rambauske
Ronald Hodge**

**University of Dayton
Research Institute
Dayton 9, Ohio**

**Prepared for:
Aeronautical Systems Division
Air Force Systems Command
Reconnaissance Laboratory
Wright Patterson Air Force Base, Ohio**

HEADQUARTERS
Aeronautical Systems Division

AIR FORCE SYSTEMS COMMAND
UNITED STATES AIR FORCE
WRIGHT-PATTERSON AIR FORCE BASE, OHIO

REPLY TO
ATTN. OF: ASRNR-32

28 May 1963

SUBJECT: Transmittal of Reports

TO: ASTIA
Arlington Hall Sta
Arlington 12 Va

Transmitted herewith for distribution are copies of reports generated on Contract AF 33(657)9014 as follows:

5 copies unclassified Quarterly Progress Report, Part 2
1 October 1962 - 31 December 1962
Title: "Deviation from Lambertian Optical Reflection for Several Standard Surface Materials"

5 copies unclassified Quarterly Progress Report
1 January 1963 - 31 March 1963
Title: "Investigation of Laser Beam Cross-Section with Respect to Intensity and Time"

FOR THE COMMANDER

Leolin E. Long

LEOLIN E. LONG
Chief, Optronics Branch
Reconnaissance Division

2 Atch
1. Quart. Prog. Rept., Part 2
1 Oct 63 - 31 Dec 62, Contr
AF 33(657)9014, 5 cys
2. Quart. Prog. Rept., Contr
AF 33(657)9014, 1 Jan 63 -
31 Mar 63

TABLE OF CONTENTS

	Page
1. Introduction	1
2. Work Performed	1
3. Equipment	2
4. Measurements	4
5. Discussion of Results	7
APPENDIX. TABLES AND GRAPHS	9

LIST OF FIGURES

Figure		Page
1	Schematic Diagram of Photometric Equipment	10
2	Schematic Diagram Showing Orientation of Sample and Defining Angles of Incidence and Reflection	11
3	Schematic Diagrams of Samples	12
4	Transmission of Optics Technology Filter #656	13
5	Transmission of Optics Technology Filter #546	14
6	Transmission of Optics Technology Filter #436	15
7	Gaertner L124 High Precision Spectrometer and Apparatus	16
8	Spectrometer with Sample on Table	17

LIST OF TABLES

Table		Page
1	Ratios I_{r1}/I_{r2} (Sample: MgO #3, No Filter)	18
2	Ratios I_{r1}/I_{r2} ($i=0^\circ$)	19
3	Ratios I_{r1}/I_{r2} ($i=20^\circ$)	20
4	Ratios I_{r1}/I_{r2} ($i=40^\circ$)	21
5	Ratios I_{r1}/I_{r2} ($i=60^\circ$)	22
6	Background Off Sample Support	23

NOMENCLATURE

i	Angle of Incidence Measured Between the Light from the Collimator and the Normal to the Sample Surface.
r	Angle of Reflection Measured Between the Reflected Light Received by the Telescope and the Normal to the Sample Surface
I_i	Current Reading on the Electrometer Corresponding to the Incident Light Flux (Plus the Background) Weighted by the Sensitivity of the Photomultiplier Plus Dark Current
I_r	Current Reading on the Electrometer Corresponding to the Reflected Light Flux from the Sample in a Cone of 10 Arcminutes Plus the Background Weighted by the Sensitivity of the Photomultiplier Plus Dark Current.
I_i'	I_i Adjusted for Background, Dark Current, Lamp Voltage and Reference.
I_r'	I_r Adjusted for Background, Dark Current, Lamp Voltage and Reference.
b.c.	Current Reading with Room Lights Off, Light from the Collimator Closed Off and Telescope Open.
d.c.	Dark Current of Photomultiplier (d.c. = b.c.)
B.G.	Total Background, equal to b.c. Plus Background Off Sample Support (with Disc Removed) with Light from the Collimator Present.
ref.	Reference
t	Thickness of Sample Coating.
$2r$	Diameter of Sample.
Wr #	Wratten Filter Number.
ND #	Neutral Density Number Optics Technology Filters.
MgO #3	Disc Sample Coated with MgO ($t=2.0\text{mm}$)
W.P. #1	First White Paint Sample Coating.

QUARTERLY PROGRESS REPORT

Contract AF 33(657)-9014

1 October 1962 - 31 December 1962

1. INTRODUCTION

This is Part 2 of the second Quarterly Progress Report submitted in partial fulfillment of the requirements of Contract AF 33(657)-9014. The report covers a phase of the work completed during the period 1 October 1962 through 31 December 1962, and is concerned with the experimental determination of the degree of departure from Lambertian optical reflection for several standard surface materials.

2. WORK PERFORMED

In conjunction with the determination of optical cross-sections of various geometrical bodies, this report is concerned with the investigation of the departure from Lambertian optical reflection for several standard surface materials under different angles of incidence. As the measurements of the near horizontal reflecting power which were made for standard geometrical bodies and models of actual targets did show discrepancies with values calculated according to simple laws of reflection, a more thorough investigation of the actual prevailing relations was indicated. If one wants to perform integrations over various surface shapes in order to find an estimated value for the reflected power, one usually assumes complete diffusion according to Lambert's law. However, in every case of a material used for the surface of an actual target very substantial deviations from complete diffusion can exist and sometimes even specular reflection may occur.

Although investigations and measurements about these problems have been done in the past, they are not applicable for specific optical radar and photometric problems such as detection, recognition, and tracking of artificial targets. The reasons are:

- 1) Measurements are not easily accessible (1870-1920) and were published a long time ago.
- 2) The accuracy of these measurements is not too reliable because visual photometry instead of photoelectric measurements was employed.

- 3) From the almost infinite variety of materials those were investigated which have practically no bearing on modern space and aircraft designs.
- 4) Since problems of this kind were of no great importance in the time when investigated, one cannot derive, because of the scarcity of the data, relationships which are applicable for today's problems of optical cross-sections.

The behavior of reflected coherent light, especially when of narrow band-width and a high degree of polarization as is given in most cases of laser illumination, will be even more particular for specific materials and surface arrangements. Hence it is intended to compare the values given in this report which will serve as standards with those found under the same conditions by laser illumination. Sets of measurements of this kind will then lead to the prediction of the general behavior of certain surface materials and surface forms. Mathematically, these sets of measurements will be approximated by empirical equations which express the reflected power as a function of angle of incidence and some prevalent parameters of material reflection coefficient and body shape factor.

Several diffuse samples were investigated which approach an ideally diffuse surface, and these measurements were compared to measurements of reflections from a special white paint and from polished aluminum. The source of illumination was incandescent incoherent light. The investigation of other materials will be added in the future.

3. EQUIPMENT

The experiments were conducted in the X-Ray Laboratory at the University of Dayton, Dayton, Ohio. In this laboratory the surroundings could be darkened to less than the noise level of the measuring device. Furthermore the photometric system was curtained off in one corner with the electrometer and observer outside while the measurements were being made.

The experiment was set up on a Gaertner L124 high precision spectrometer which had already been aligned to ± 1 arc second for previous experimentation and checked with a calibrated prism obtained from the National Bureau of Standards.

A tungsten ribbon filament lamp (G.E. 18A/T10/1) and a condensing lens were sealed into a box at one end of the collimator and ventilated as shown in Figure 1. The ribbon filament was imaged on the entrance aperture of the collimator by the condensing lens and aligned so that a uniform beam of parallel

light was obtained from the collimator. A 6 Vdc, 18 amps, regulated lamp power supply built at the University of Dayton was monitored to ± 0.01 volts. Filters could be placed immediately in front of the entrance aperture. This aperture was square and its width subtended an angle of 10 arcminutes at the center of the spectrometer the dimensions of which are shown in Figure 1. The sample was mounted on the rotation axis of the spectrometer in the center of the beam of collimated light. (See Figure 2.) Only the sample and part of its supporting shaft were in the beam of incident light. The sample was aligned perpendicular to the incident light by auto-collimating on its back surface which was nearly plane parallel with the front surface. The alignment was checked at the end of a series of measurements. The spectrometer table could be rotated in one plane and angles of incidence i were set with the circular scale attached to the table and could be read to ± 1 arcminute with a vernier.

Reflected light was observed through the telescope with a photomultiplier fixed to the exit aperture. The photomultiplier used was type 931A (Sylvania Electric Products, Inc.) with an S4 response and an average sensitivity of 30 $\mu\text{amp/lumen}$ for tungsten light. It was powered with N.J.E. Corporation Model S-326 high voltage power supply at 1000 volts dc with a ripple content of only one part in 100,000. Current was detected with a Keithley Model 610A electrometer. The telescope was positioned opposite the collimator, and a stop with a circular aperture of 10 arcminutes subtended from the center of the spectrometer was placed in the focal plane of the telescope (this position was determined with a small error of up to 1 millimeter) and in juxtaposition with the image of the entrance aperture of the collimator. The spectrometer circle was zeroed to read 180° for this position of the telescope. The photomultiplier was securely attached with the cathode surface 3cm behind the focal plane and was not moved from this fixed position throughout a set of measurements.

A black felt cloth backdrop was hung opposite the telescope, and the photomultiplier housing was taped and surrounded with black cloth. The spectrometer table was covered with black felt paper, and surfaces near the sample were painted flat black.

Angular setting of the spectrometer and readings on the electrometer were made directly. Temperature and humidity were kept constant at $24^\circ\text{C.} \pm 1^\circ\text{C.}$ and $15\% \pm 5\%$ respectively.

4. MEASUREMENTS

Measurements were made on the following seven samples:

- 1) A front surface mirror, whose surface area was 4.8cm^2 , which was simply stood on edge on the spectrometer table with the lower edge stopped off.
- 2) The same front surface mirror employed as a diffuse sample after it was smoked with MgO to a coating thickness of $t=0.5\text{mm}$.
- 3) Similar to sample #2 except the mirror was smoked with MgO to a coating thickness of $t=1.0\text{mm}$.
- 4) An aluminum disc ($2r=2.5\text{cm}$, $A=5.0\text{cm}^2$) smoked with MgO to a coating thickness $t=2\text{mm}$. The aluminum surface was highly polished although the edges were slightly rounded. The rim was covered with black felt paper and the vertical supporting shaft was painted flat black.
- 5) A highly polished and somewhat flatter end of a cylinder ($2r=2.5\text{cm}$) fine sprayed with a special white paint received from Surveillance Branch, Reconnaissance Laboratory, Wright-Patterson Air Force Base, Ohio, to about a two or three coat thickness. The surface appeared very smooth and wet even after it had dried. The side edges of the cylindrical body were painted flat black.
- 6) The same cylinder with a much heavier smooth coat of the same paint.
- 7) The highly polished specular base of a 30° half angle aluminum cone ($2r=2.5\text{cm}$) was measured. Again, the surface, though well polished, was slightly rounded near the edge. The lateral surface of the cone was painted flat black.

The background current (b.c.) given in the data sheets is the photomultiplier readings obtained with room lights off, collimator closed and telescope open to catch stray background reflections. It was equal to the photomultiplier dark current in all instances and therefore indicates that the surroundings were sufficiently darkened.

The background of the black supporting shaft with the collimator open was measured with the sample removed (see Table 6). There is some question about the background for measurements of very large angles ($i+r$ large) due to the secondary reflection from

the front of the collimator and scattered light from its lens. The telescope did not see the illuminated blackened surfaces of the sample except for a few measurements on the negative side. These measurements seemed to be only slightly affected, if at all, by the reflected light from these blackened surfaces.

The background from the shaft at any telescope setting was added to the background current and this sum subtracted from the sample reflection current reading. Improvements in sample mount that will reduce background are shown in Figure 3. The entire equipment area has since been painted flat black.

Adjustments were made in the readings for lamp voltage variation. At $I_r = 1.80 \times 10^{-7}$ amps a change in lamp voltage of 0.02 volts resulted in an average change of 0.035×10^{-7} amps in I_r and this corresponding correction was applied proportionately to each reading.

Measurements of the incident light I_i were made by replacing the sample as accurately as possible with a stop opening in the same position. Measurements were made at four angles of incidence. Each value was divided by the cosine of the angle of incidence at which it was obtained and these quotients, which were nearly equal, were averaged to obtain the full incident light I_i at normal incidence ($i=0^\circ$). Measurements were made both with the stop in the focal plane of the telescope in place and with this stop removed. In this way it should be possible to detect any uncollimated light in the incident beam since this uncollimated light would be focused by the telescope outside the image of the entrance aperture. Very little uncollimated light was observed in the incident beam visually and so a value for the incident light (I_i) was taken for measurements with the stop in the telescope removed.

Specular reflections from white paint and aluminum were measured with the stop in the focal plane of the telescope. Since angles of incidence could only be set with a precision of ± 2 arcminutes on the graduated circle attached to the spectrometer table, measurements of specular reflections were made by varying the telescope position slightly and observing maximum readings. In measuring the specular reflections off the special white paint not all of the specular reflection was received through the exit aperture because the surface of the white paint only approximates a pure specular surface. Therefore the reflected light measurements represent the total light flux emitted from the sample in a cone of 10 arcminutes.

Measurements of incident light (I_i) and specular reflections had to be taken using ND filters. The transmission of these filters was measured separately but because of the limited range of the photomultiplier it was not possible to measure them in combination at this time. This measurement was needed for

determining I_i . A nominal value of 10^{-6} was therefore taken for the transmission of ND #2, #3, and #1 in combination. However, this value is sufficient for presenting the information which is of interest now.

Measurements were made with white light of tungsten at 5.00 volts and with Optics Technology interference filters #436, #546, and #656 with a band pass as shown in Figures 4, 5 and 6. These measurements of the reflected light are dependent upon the sensitivity of the photomultiplier as a function of wavelength, and when the photomultiplier is calibrated it will be possible to take into consideration the selective reflection of these samples. Measurements were made for $i=0^\circ, 20^\circ, 40^\circ, 60^\circ, 80^\circ$ and r was varied in 10° steps and in one degree steps around points of interest such as $i=r$, the surface normal and at large angles greater than 85° .

After the preliminary measurements on the first few samples, all data for the diffuse reflection for the MgO coated disc and samples coated with white paint were normalized in the following way. For each set of measurements at an angle of incidence (i) a reference measurement at $i=0^\circ, r=45^\circ$ was made. Ratios were taken of the reference measurements off MgO and also the reference measurement off white paint to the unstopped full beam with the telescope at 180° and the sample removed and with the same combination of neutral density filters. The incident light (I_i) upon the samples was also referenced to the full beam at 180° with the same conditions as above. By comparing these reference measurements, data which were taken with these references respectively could be compared by assuming that all the readings taken at one time were proportional to the readings taken at another time and differed only because of the change in sensitivity of the photomultiplier or possible change in the light source. A number of check measurements were made for the same sample at the same angles i and r only at different times and different references existing, and were found to be in good agreement when compared to these references. This procedure was necessary in order to make all measurements without removing the photomultiplier.

Moreover, improvements in the equipment and measuring technique are intended as they are indicated by the present experiments. An Eppley Thermopile and a Standard light source from the National Bureau of Standards have been received with which the light source should be calibrated. The response curve of several photomultipliers can also be calibrated in order to assure reliability and to compare results for different wavelengths. The circuits of the photomultipliers will be improved to lower noise level of about 10^{-11} so that a better signal to noise ratio and a little wider range is possible. The range of the 931A photomultiplier used was not great enough to measure the incident light or specular reflections without several ND filters in combinations

mentioned previously. An improved power supply for the lamp is being built and a means for holding the current through the lamp constant will be included.

The overall experimental error was not more than ± 1 digit in the second significant digit.

Another effect to be considered is the finite size of the entrance and exit apertures. The reflected intensity measured is actually an integration of the light from a cone of ± 5 arcminutes and this collection would change with different angles of incidence. By increasing the light source and decreasing dark current, the size of openings can be decreased and the precision of the photometric measurements increased.

5. DISCUSSION OF RESULTS

5.1 Specular Front Surface Mirror

The specular reflection percentage was measured for the aluminum mirror at an angle of incidence of 20° and found to be 92% in good agreement with reference works.

5.2 Front Surface Mirror Smoked with 0.5mm MgO Coating

The MgO coating was found to be too thin since a small specular peak occurred at $i=r$.

5.3 Front Surface Mirror Smoked with 1.0mm MgO Coating

The specular peak present in the previous sample disappeared with the increase in coating thickness. This minimum thickness of smoked MgO is therefore necessary to insure the absence of specular components in the reflection curve.

5.4 Polished Aluminum Disc Smoked with 2.0mm MgO Coating

The diffuse reflection from this sample was found to vary from Lambert's law in a certain definite pattern. At angles of incidence close to 45° the reflected light intensity was exactly proportional to the cosine of the angle of reflection within the limits of experimental error. At normal incidence, the reflected intensity decreased slightly with increasing angle of reflection as compared with the cosine, while for large angles of incidence the reflected intensities did not decrease with increasing angle of reflection as much as the cosine

of this angle. The reflected intensity distribution about the normal to a smoked MgO coated surface is therefore dependent on the angle of incidence at which the sample was illuminated.

Within the range of experimental accuracy no change could be found in the pattern of the reflection^o function when the incident light was filtered for different spectral regions. However, it is known that the overall intensity ratio of incident to reflected is slightly dependent on wavelength.

5.5 Polished End of Cylinder Fine Sprayed with Thin Coat of White Paint

Reflection from this sample followed the same pattern as the MgO coated sample except there was a strong reflection received at $i=r$ and an increase in the distribution of reflected light intensity about this position.

The most interesting observation, however, was that for increasing $i=r$ positions with respect to the normal to the surface, the reflected intensity increased becoming very large for $i=r=85^\circ$. This effect was obvious visually and was compared to the specular reflection obtained from a highly polished aluminum cone of the same size, in the same position and at the same angles of incidence. The reflected intensity for this aluminum disc decreased with increasing angles of incidence as expected.

5.6 Polished End of Cylinder with Thick Heavy Coat of White Paint

Results obtained for this sample were similar to the previous white paint sample.

5.7 Polished Specular Base of Aluminum Cone.

This is the sample referred to in the comparisons made of the specular reflection from white paint and a polished aluminum cone in section 5.5 of this report.

Werner Kambauske

Dr. Werner Kambauske
Principal Research Investigator

Ronald Hodge
Ronald Hodge
Assistant Research Physicist

APPENDIX

Tables and Graphs

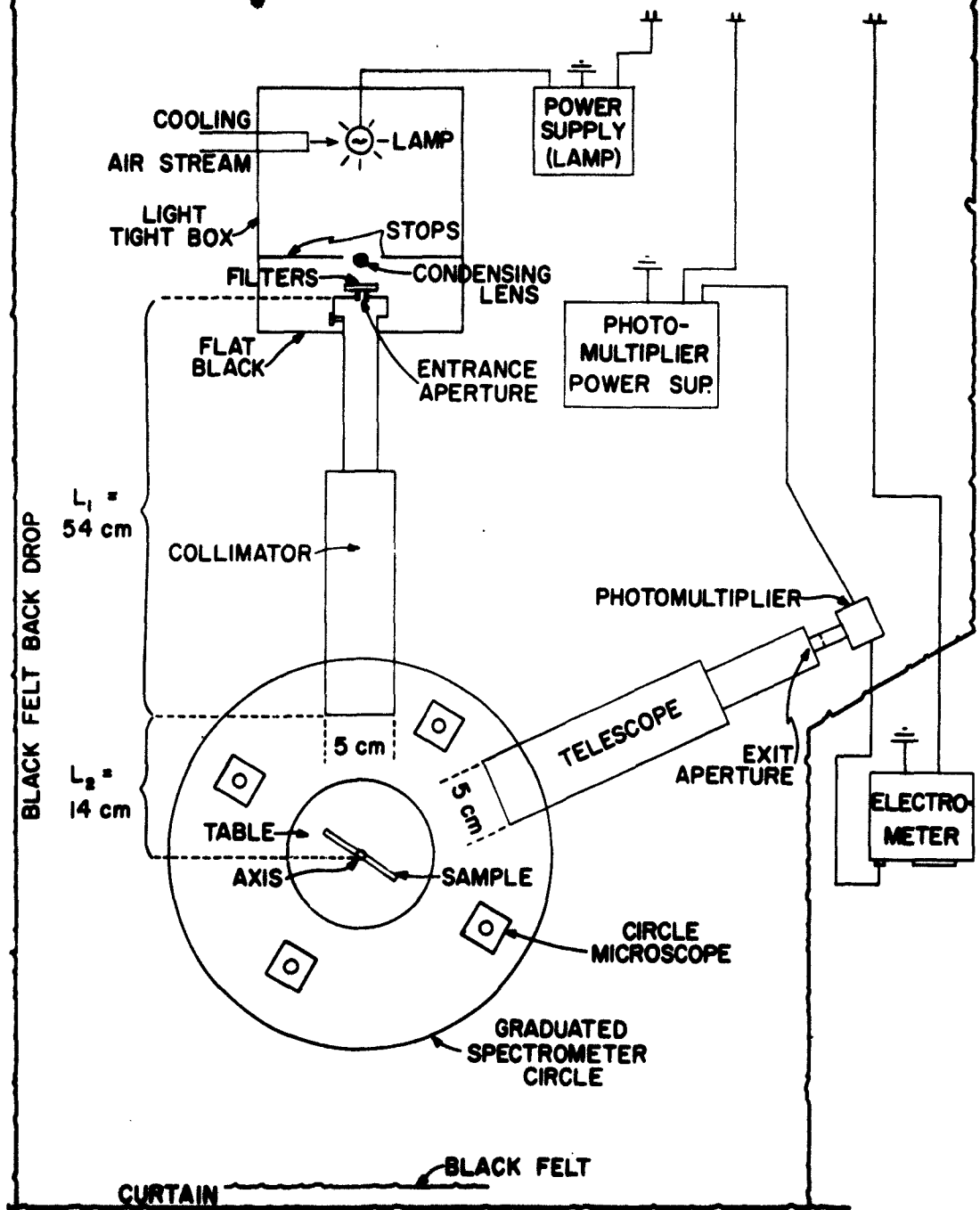

Figure 1. Schematic Diagram of Photometric Equipment.

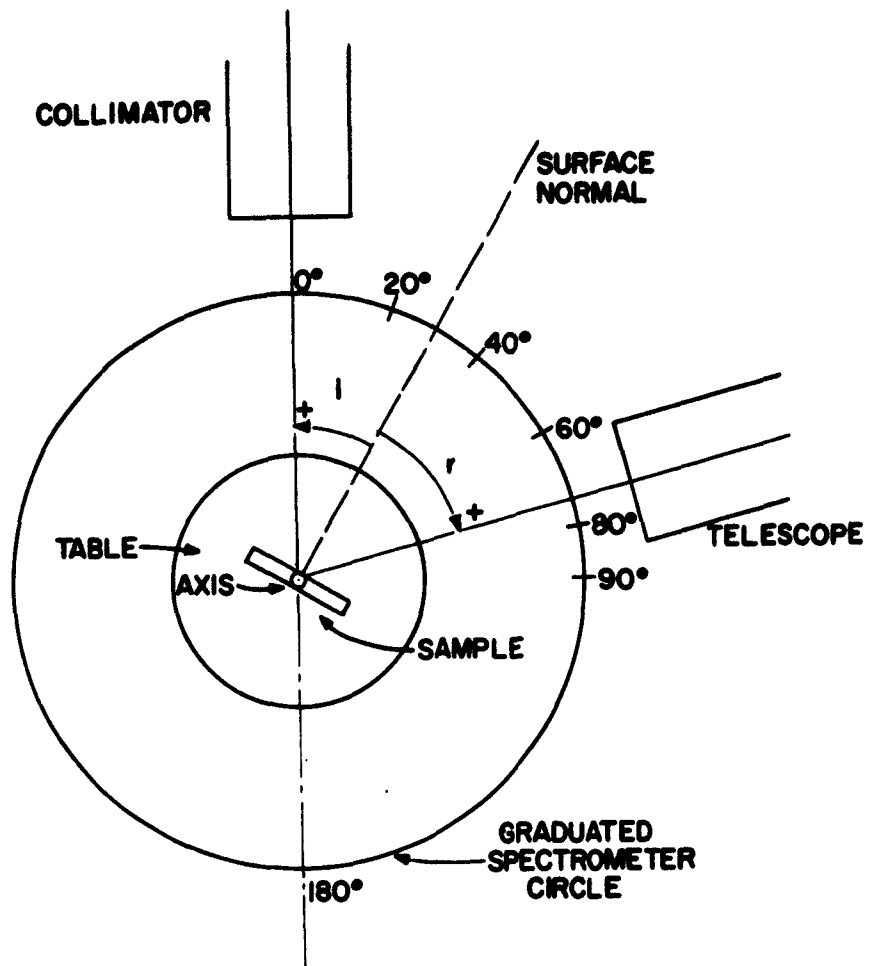
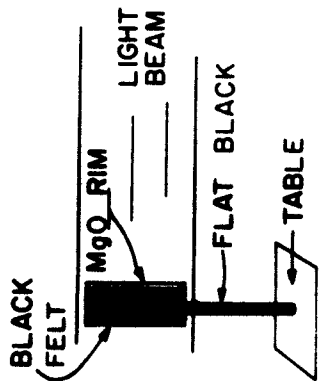
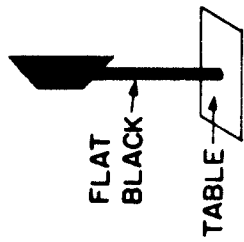

Figure 2. Schematic Diagram Showing Orientation of Sample and Defining Angles of Incidence and Reflection.



DISC SAMPLE



IMPROVED DISC SAMPLE

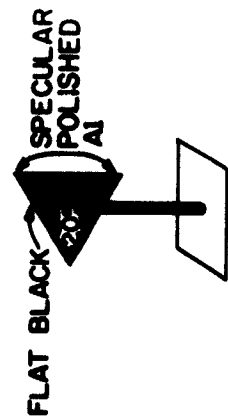

CONE SAMPLE

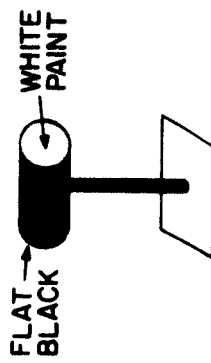

CYLINDER SAMPLE

Figure 3. Schematic Diagrams of Samples.

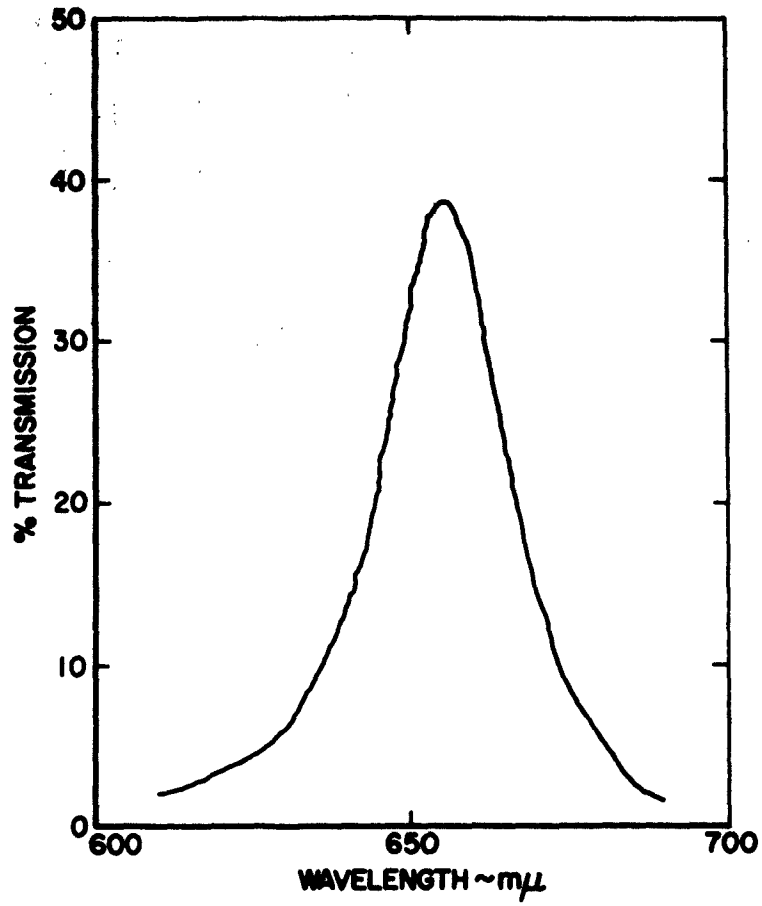

Figure 4. Transmission of Optics
Technology Filter #656

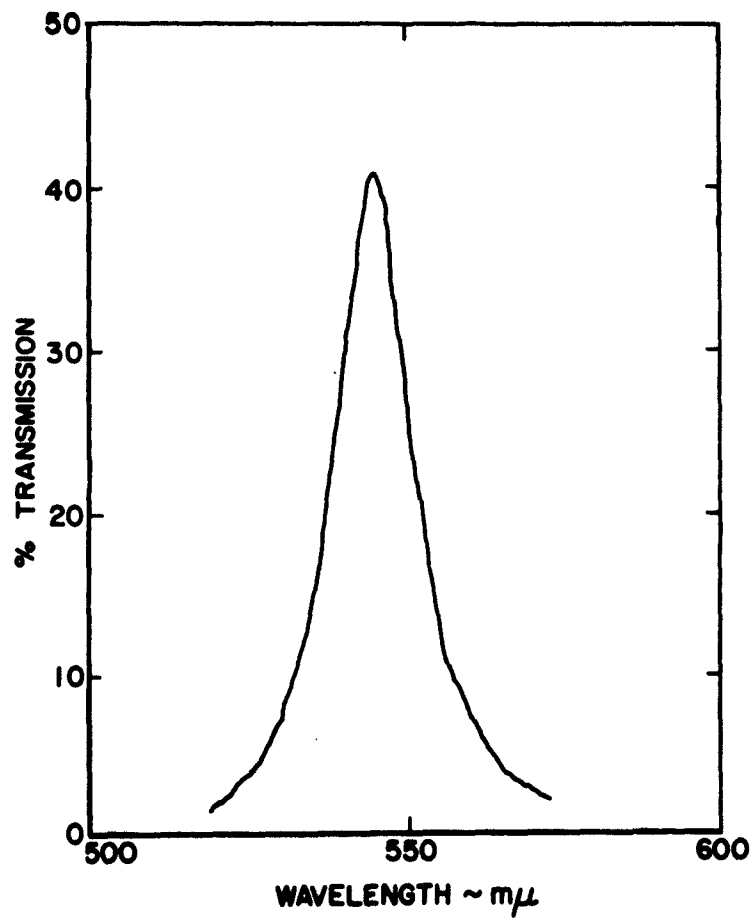

Figure 5. Transmission of Optics
Technology Filter #546

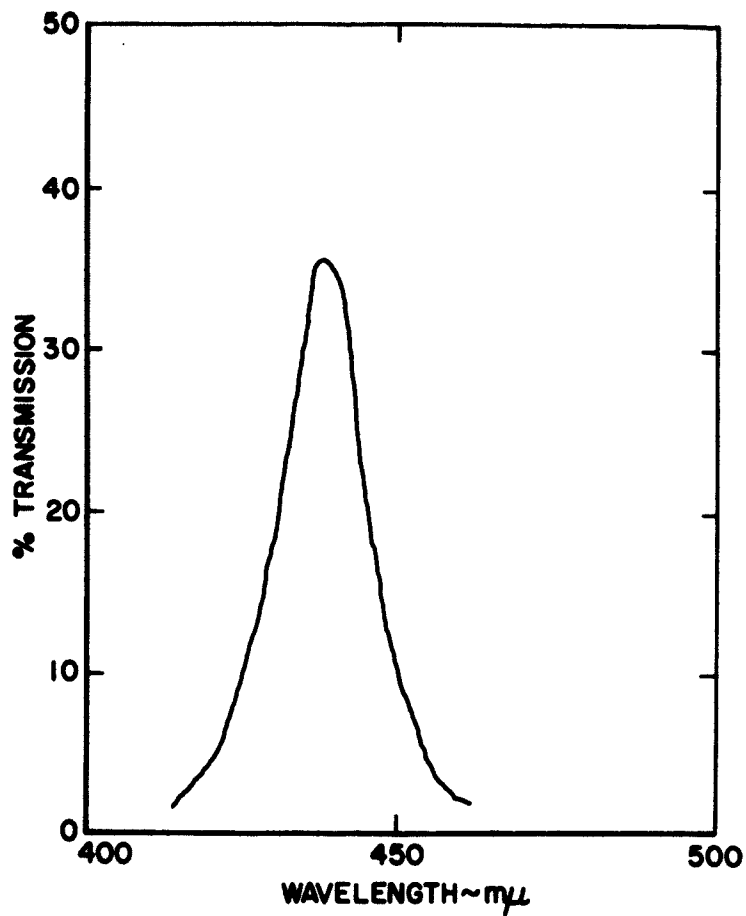

Figure 6. Transmission of Optics Technology Filter #436



Figure 7. Gaertner L124 High Precision Spectrometer and Apparatus.

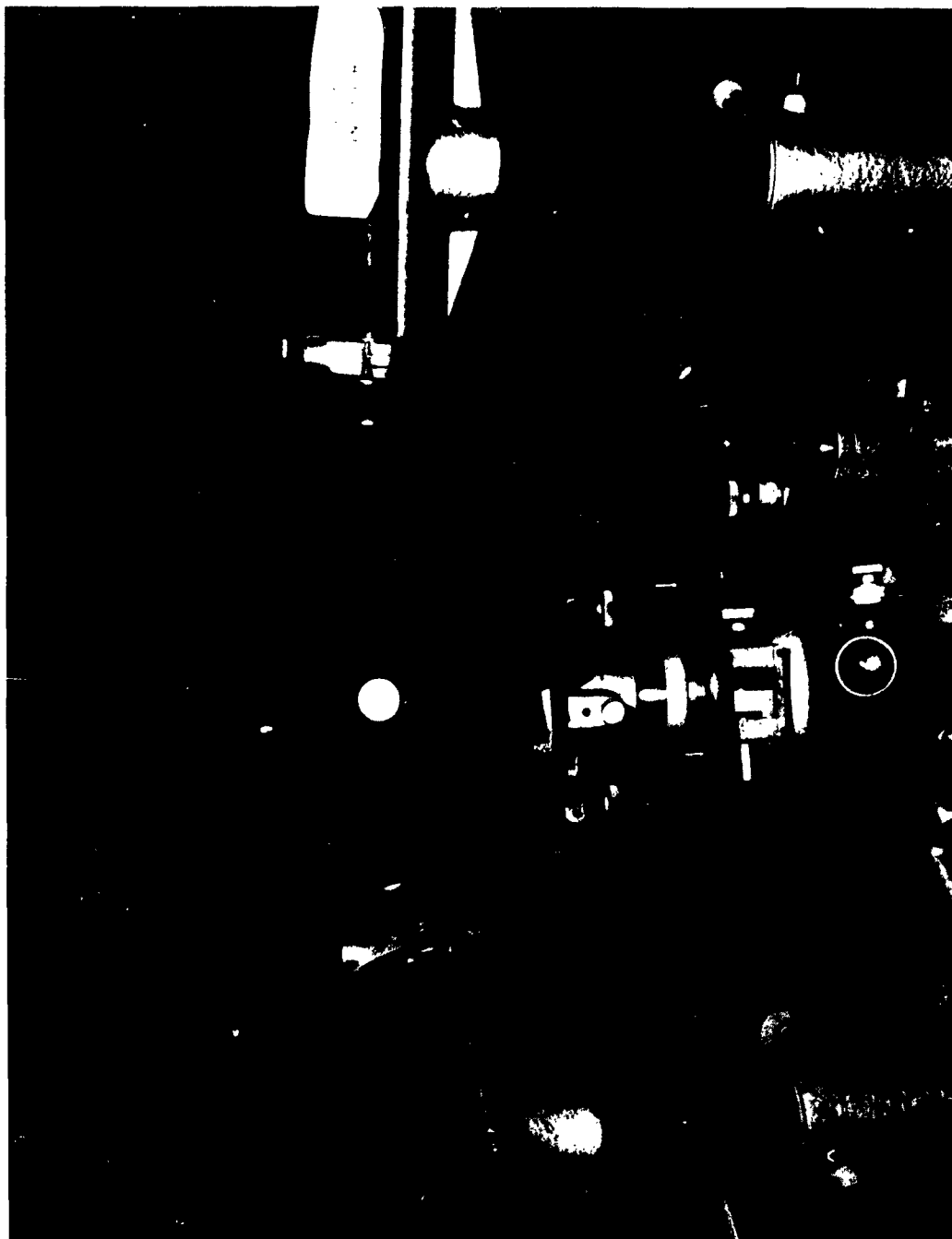

Figure 8. Spectrometer with Sample
on Table.

TABLE 1. RATIOS I_{R1}/I_{R2}

Sample: MgO #3, No Filter

$R_1:R_2$	$i=0^\circ$	$i=20^\circ$	$i=40^\circ$	$i=60^\circ$	$i=80^\circ$	$\cos r$	$f(r)=[1-1.3 \sin^2(\frac{r}{2})] \cos r$
$0^\circ:10^\circ$			1.03	1.02	1.01	1.02	1.03
$10^\circ:20^\circ$			1.07	1.03	1.02	1.05	1.08
$20^\circ:30^\circ$		1.11	1.07	1.07	1.02	1.09	1.14
$30^\circ:40^\circ$		1.15	1.12	1.09	1.03	1.13	1.22
$40^\circ:50^\circ$	1.20	1.22	1.20	1.13	1.02	1.19	1.32
$50^\circ:60^\circ$	1.32	1.32	1.30	1.17	1.01	1.29	1.46
$60^\circ:70^\circ$	1.55	1.54	1.47	1.28	1.05	1.46	1.72
$70^\circ:80^\circ$	2.00	2.01	1.90	1.65		1.97	2.43

TABLE 2. RATIOS I_{r1}/I_{r2}
($i=0^\circ$)

$I_1:I_2$	MgO #3		MgO #3		MgO #3		W.P. #1		Cos τ
	No Filter	Blue #436	Green #546	Red #656	No Filter	No Filter	No Filter		
$0^\circ:10^\circ$									1.02
$10^\circ:20^\circ$									1.05
$20^\circ:30^\circ$									1.09
$30^\circ:40^\circ$									1.13
$40^\circ:50^\circ$	1.20	1.23	1.19	1.23	1.22				1.19
$50^\circ:60^\circ$	1.32	1.39	1.35	1.36	1.30				1.29
$60^\circ:70^\circ$	1.55	1.55	1.65	1.64	1.58				1.46
$70^\circ:80^\circ$	2.00	2.56	2.22		2.55				1.97

TABLE 3. RATIOS I_{r1}/I_{r2}

($i=20^\circ$)

$r_1:r_2$	MgO #3 No Filter	MgO #3 Blue #436	MgO #3 Green #546	MgO #3 Red #656	Cos r
$0^\circ:10^\circ$					1.02
$10^\circ:20^\circ$					1.05
$20^\circ:30^\circ$	1.11	1.10	1.11	1.14	1.09
$30^\circ:40^\circ$	1.15	1.14	1.14	1.20	1.13
$40^\circ:50^\circ$	1.22	1.23	1.20	1.21	1.19
$50^\circ:60^\circ$	1.32	1.35	1.32	1.41	1.29
$60^\circ:70^\circ$	1.54	1.56	1.56	1.57	1.46
$70^\circ:80^\circ$	2.01	2.37	2.17	2.53	1.97

TABLE 4. RATIOS I_{T1}/I_{T2}

($i=40^\circ$)

$T_1:T_2$	MgO #3	MgO #3	MgO #3	MgO #3	(at $i=45^\circ$)		Cos r
	No Filter	Blue #436	Green #546	Red #656	No Filter	W.P. #1	
$0^\circ:10^\circ$	1.03	1.02	1.04	1.02	1.03	1.02	1.02
$10^\circ:20^\circ$	1.07	1.05	1.06	1.06	1.05	1.05	1.05
$20^\circ:30^\circ$	1.07	1.06	1.07	1.10	1.07	1.09	1.09
$30^\circ:40^\circ$	1.12	1.16	1.12	1.15	Spec.	1.13	1.13
$40^\circ:50^\circ$	1.20	1.16	1.21	1.17	Spec.	1.19	1.19
$50^\circ:60^\circ$	1.30	1.30	1.32	1.37	Spec.	1.29	1.29
$60^\circ:70^\circ$	1.47	1.50	1.45	1.45	1.63	1.46	1.46
$70^\circ:80^\circ$	1.90	2.72(?)	2.05	2.26	2.51	1.97	1.97

TABLE 5. RATIOS I_{T1}/I_{T2}

($i=60^\circ$)

$T_1:T_2$	MgO #3	MgO #3	MgO #3	MgO #3	(i=85°)	
	No Filter	Blue #436	Green #546	Red #656	W.P. #1	Cos r
0°:10°	1.02	1.02	1.00	1.00	1.01	1.02
10°:20°	1.03	1.04	1.05	1.05	1.03	1.05
20°:30°	1.07	1.01	1.06	1.12	1.05	1.09
30°:40°	1.09	1.10	1.08	1.10	1.09	1.13
40°:50°	1.13	1.17	1.12	1.11	Spec.	1.19
50°:60°	1.17	1.19	1.20	1.24	Spec.	1.29
60°:70°	1.28	1.36	1.35	1.58	Spec.	1.46
70°:80°	1.65	2.23	1.70	2.50	Spec.	1.97

TABLE 6. BACKGROUND OFF SAMPLE SUPPORT

Telescope Setting (=i+r)	Background Current Off Shaft	Dark Current
35°	2.22 x 10 ⁻⁹ amps	1.90 x 10 ⁻⁹ amps
40°	2.20 x 10 ⁻⁹ amps	1.90 x 10 ⁻⁹ amps
45°	2.18 x 10 ⁻⁹ amps	1.90 x 10 ⁻⁹ amps
50°	2.18 x 10 ⁻⁹ amps	1.90 x 10 ⁻⁹ amps
60°	2.18 x 10 ⁻⁹ amps	1.90 x 10 ⁻⁹ amps
70°	2.16 x 10 ⁻⁹ amps	1.90 x 10 ⁻⁹ amps
80°	2.15 x 10 ⁻⁹ amps	1.90 x 10 ⁻⁹ amps
90°	2.13 x 10 ⁻⁹ amps	1.90 x 10 ⁻⁹ amps
100°	2.13 x 10 ⁻⁹ amps	1.90 x 10 ⁻⁹ amps
110°	2.12 x 10 ⁻⁹ amps	1.90 x 10 ⁻⁹ amps
120°	2.12 x 10 ⁻⁹ amps	1.90 x 10 ⁻⁹ amps
130°	2.22 x 10 ⁻⁹ amps	1.90 x 10 ⁻⁹ amps
140°	2.32 (?)	1.90 x 10 ⁻⁹ amps
150°	2.42 (?)	1.90 x 10 ⁻⁹ amps
160°	(?)	1.90 x 10 ⁻⁹ amps

SPECTROMETER DATA

Contract AF 33(657)-9014

Record number	<u>1</u>	Incidence	<u>$i=0^\circ$</u>
Type Reflection	<u>Diffuse</u>	Filter	<u>None</u>
Remarks:		Sample	<u>Diffuse Standard</u>
		Dimensions	<u>Disc, $2r=2.5\text{cm}$</u>
		Coating	<u>MgO #3, $t=2\text{mm}$</u>

Incident Light	<u>$I_i=0.298 \cos 0^\circ$</u>
Adj. Ref. for I_i	<u>1.66×10^{-7}</u>
I'_i (adj. for ref.)	<u>0.242</u>

Reference:	<u>at $i=0^\circ, r=45^\circ$</u>
For reflected light	<u>$I_r=1.41 \times 10^{-7}$</u>
Filter	<u>None</u>
b.c.	<u>1.34×10^{-9}</u>
Lamp	<u>5.00 volts</u>
I'_r adj.	<u>1.35×10^{-7}</u>

r	$I_r \times 10^7$ (amps)	Lamp Voltage (volts)	b.c. $\times 10^9$ (amps)	$I'_r \times 10^7$ (amps)	$(I'_r/I'_i) \times 10^7$
35°	1.63	5.00	1.31	1.57	6.49
40°	1.51	5.00	1.32	1.45	5.99
50°	1.26	5.00	1.34	1.21	5.00
60°	0.960	5.00	1.34	0.920	3.80
70°	0.625	5.00	1.33	0.592	2.45
80°	0.312	5.00	1.33	0.296	1.22
85°	0.169	5.00	1.33	0.153	0.632
-40°	1.57	5.00	1.36	1.51	6.24
-50°	1.28	5.00	1.35	1.23	5.08
-60°	0.960	5.00	1.37	0.920	3.80
-70°	0.610	5.00	1.37	0.581	2.40
-80°	0.300	5.00	1.37	0.284	1.17
-85°	0.166	5.00	1.40	0.150	0.619

Function of the Angle of Reflection $f(r) = (I'_r/I'_i) \times 10^7$

Record Number 1

○—○ $f(r)$ Measured
x—x $f(r) = \cos r$

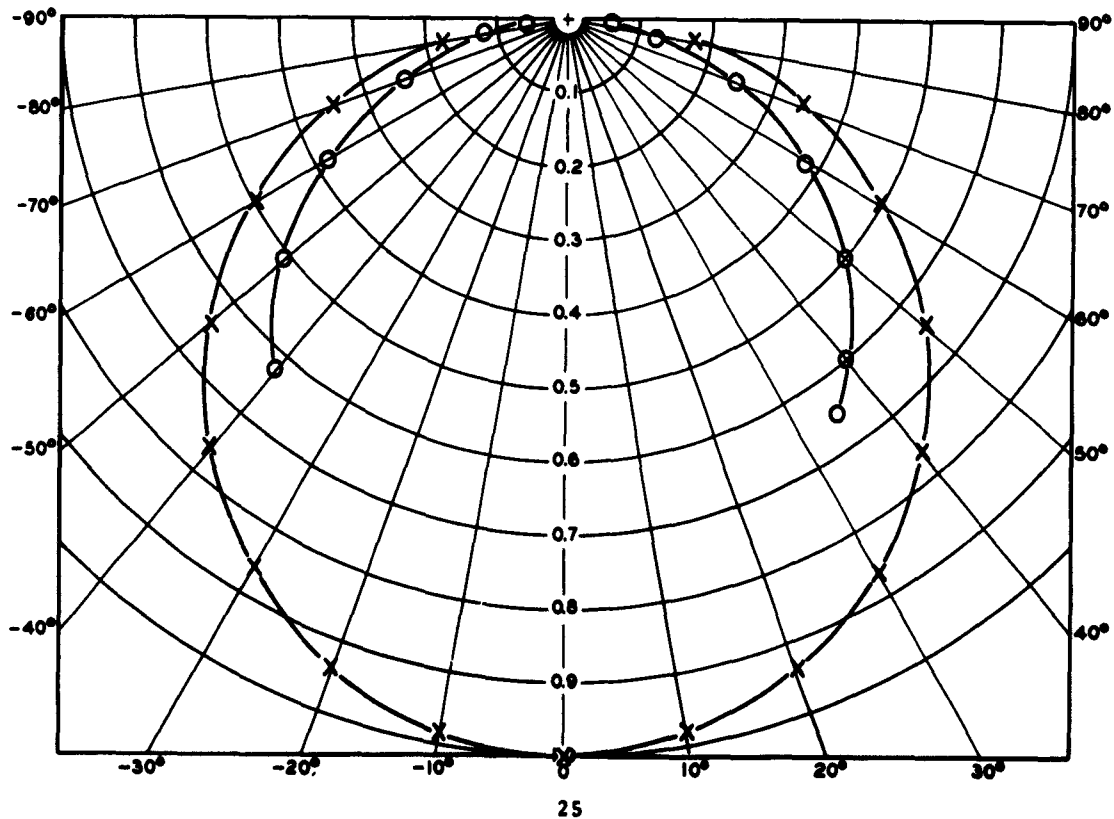

SPECTROMETER DATA

Contract AF 33(657)-9014

Record number	<u>2</u>	Incidence	<u>i=20°</u>
Type Reflection	<u>Diffuse</u>	Filter	<u>None</u>
Remarks:		Sample	<u>Diffuse Standard</u>
		Dimensions	<u>Disc, 2r=2.5cm</u>
		Coating	<u>MgO #3, t=2mm</u>
Incident Light	<u>I_i=0.298 cos 20°</u>	Reference:	<u>at i=0°, r=45°</u>
Adj. Ref. for I _i	<u>1.66 x 10⁻⁷</u>	For reflected light	<u>I_r=1.41 x 10⁻⁷</u>
I _i (adj. for ref.)	<u>0.228</u>	Filter	<u>None</u>
		b.c.	<u>1.34 x 10⁻⁹</u>
		Lamp	<u>5.00 volts</u>
		I _r adj.	<u>1.35 x 10⁻⁷</u>

r	I _r x 10 ⁷ (amps)	Lamp Voltage (volts)	b.c. x 10 ⁹ (amps)	I _r ' x 10 ⁷ (amps)	(I _r '/I _i) x 10 ⁷
15°	1.87	5.00	1.35	1.80	7.89
20°	1.80	5.00	1.36	1.74	7.63
25°	1.72	5.00	1.37	1.66	7.28
30°	1.63	5.00	1.37	1.57	6.89
40°	1.42	5.00	1.37	1.37	6.01
50°	1.17	5.00	1.37	1.12	4.91
60°	0.890	5.00	1.37	0.849	3.72
70°	0.580	5.00	1.37	0.551	2.42
80°	0.297	5.00	1.37	0.274	1.20
85°	0.168	5.00	1.37	0.148	0.649
86°	0.141	5.00	1.37	0.121	0.530
87°	0.118	5.00	1.37	0.099	0.434
88°	0.097	5.00	1.37	0.079	0.346
90°	0.057	5.00	1.37	0.040	0.175
18°	1.82	5.00	1.37	1.76	7.72
19°	1.81	5.00	1.37	1.75	7.67
20°	1.79	5.00	1.37	1.73	7.59
21°	1.78	5.00	1.37	1.72	7.54
22°	1.77	5.00	1.37	1.71	7.50

Function of the Angle of Reflection $f(r) = (I'_r / I'_i) \times 10^7$

Record Number 2
○—○ $f(r)$ Measured
X—X $f(r) = \cos r$

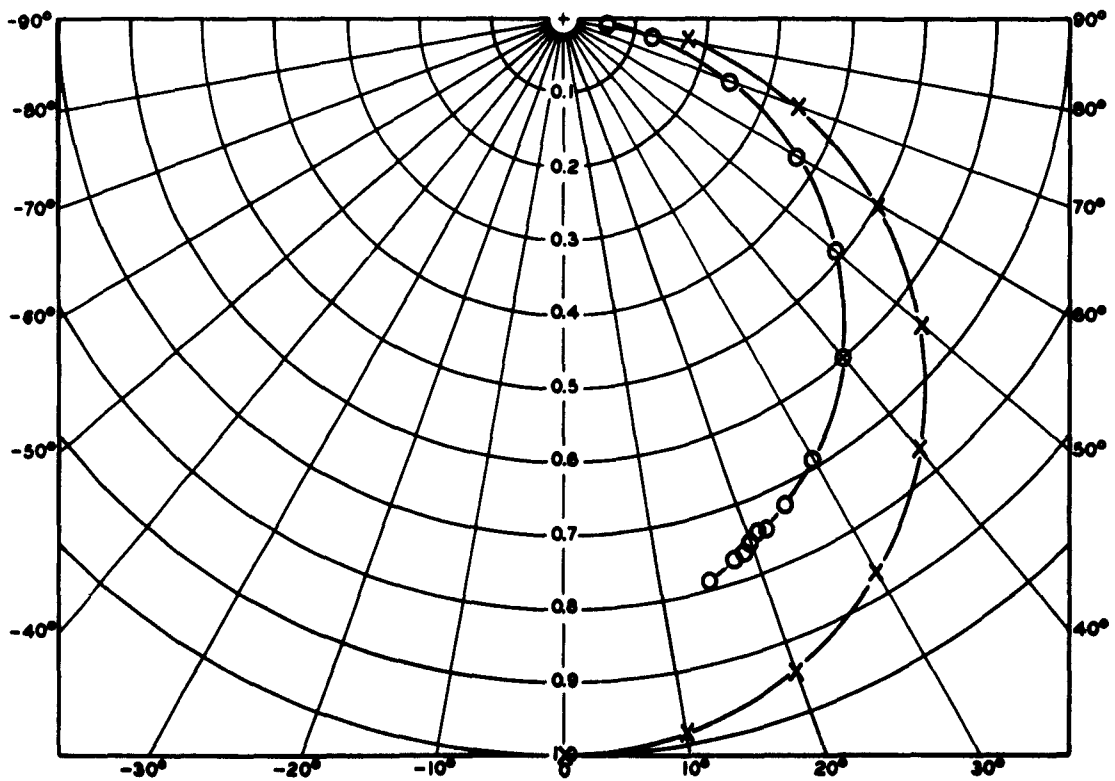

SPECTROMETER DATA

Contract AF 33(657)-9014

Record number	<u>3</u>	Incidence	<u>$i=20^\circ$</u>
Type Reflection	<u>Diffuse</u>	Filter	<u>N.D. #0.5</u>
Remarks:		Sample	<u>Diffuse Standard</u>
		Dimensions	<u>Disc, 2r=2.5cm</u>
		Coating	<u>MgO #3, t=2mm</u>
Incident Light	<u>$I_i=0.0943 \cos 20^\circ$</u>	Reference:	<u>at $i=0^\circ, r=45^\circ$</u>
Adj. Ref. for I_i	<u>1.66×10^{-7}</u>	For reflected light	<u>$I_r=1.41 \times 10^{-7}$</u>
I'_i (adj. for ref.)	<u>0.0721</u>	Filter	<u>None</u>
		b.c.	<u>1.34×10^{-9}</u>
		Lamp	<u>5.00 volts</u>
		I'_r adj.	<u>1.35×10^{-7}</u>

r	$I_r \times 10^7$ (amps)	Lamp Voltage (volts)	b.c. $\times 10^9$ (amps)	$I'_r \times 10^7$ (amps)	$(I'_r / I'_i) \times 10^7$
15°	0.575	5.00	1.41	0.558	7.73
19°	0.560	5.00	1.41	0.543	7.53
20°	0.559	5.00	1.41	0.542	7.51
21°	0.554	5.00	1.41	0.537	7.44
25°	0.533	5.00	1.41	0.516	7.15
30°	0.507	5.00	1.41	0.490	6.79
40°	0.442	5.00	1.41	0.425	5.89
50°	0.365	5.00	1.41	0.348	4.82
60°	0.278	5.00	1.41	0.261	3.62
70°	0.191	5.00	1.41	0.175	2.43
80°	0.102	5.00	1.41	0.086	1.19
85°	0.061	5.00	1.41	0.045	0.624
87°	0.048	5.00	1.41	0.032	0.443

Function of the Angle of Reflection $f(r) = (I'_r/I'_i) \times 10^7$

Record Number 3
○—○ $f(r)$ Measured
X—X $f(r) = \cos r$

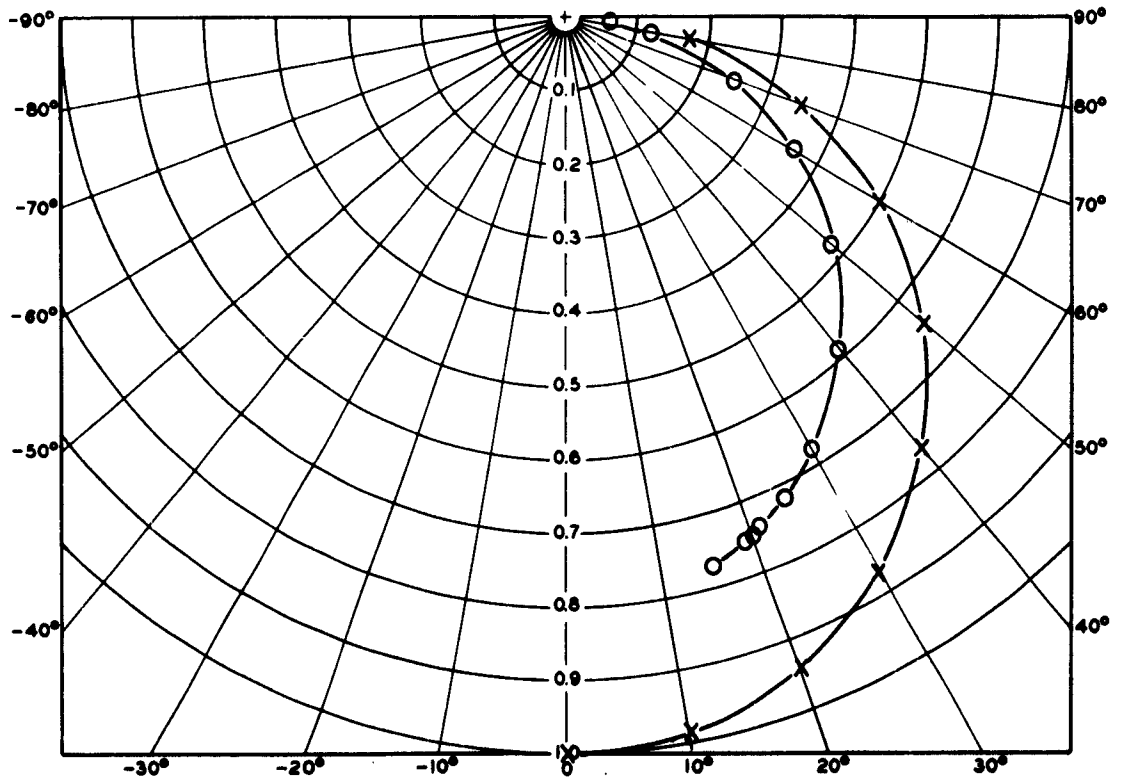

SPECTROMETER DATA

Contract AF 33(657)-9014

Record number	<u>4</u>	Incidence	<u>$i=20^\circ$</u>
Type Reflection	<u>Diffuse</u>	Filter	<u>N.D. #1</u>
Remarks:		Sample	<u>Diffuse Standard</u>
		Dimensions	<u>Disc, $2r=2.5\text{cm}$</u>
		Coating	<u>MgO #3, $t=2\text{mm}$</u>

Incident Light	<u>$I_i=0.0288 \cos 20^\circ$</u>	Reference:	<u>at $i=0^\circ, r=45^\circ$</u>
Adj. Ref. for I_i	<u>1.66×10^{-7}</u>	For reflected light	<u>$I_r=1.48 \times 10^{-7}$</u>
I'_i (adj. for ref.)	<u>0.0236</u>	Filter	<u>None</u>
		b.c.	<u>1.50×10^{-9}</u>
		Lamp	<u>5.00 volts</u>
		I'_r adj.	<u>1.45×10^{-7}</u>

r	$I_r \times 10^7$ (amps)	Lamp Voltage (volts)	b.c. $\times 10^9$ (amps)	$I'_r \times 10^7$ (amps)	$(I'_r / I'_i) \times 10^7$
-----	--------------------------	----------------------	---------------------------	---------------------------	-----------------------------

15°	0.207	5.00	1.41	0.190	8.05
19°	0.200	4.98	1.43	0.187	7.92
20°	0.197	4.98	1.43	0.184	7.80
21°	0.195	4.98	1.43	0.182	7.71
25°	0.188	4.98	1.43	0.175	7.42
30°	0.177	5.00	1.43	0.160	6.78
40°	0.161	5.01	1.43	0.143	6.06
50°	0.135	5.00	1.43	0.118	5.00
60°	0.105	5.00	1.43	0.088	3.73
70°	0.074	5.00	1.44	0.057	2.42
80°	0.044	5.00	1.44	0.027	1.14
85°	0.0304	4.99	1.44	0.0146	0.619
87°	0.0255	4.98	1.45	0.0098	0.415

Function of the Angle of Reflection $f(r) = (I_r'/I_i) \times 10^7$

Record Number 4

○—○ $f(r)$ Measured
 X—X $f(r) = \cos r$

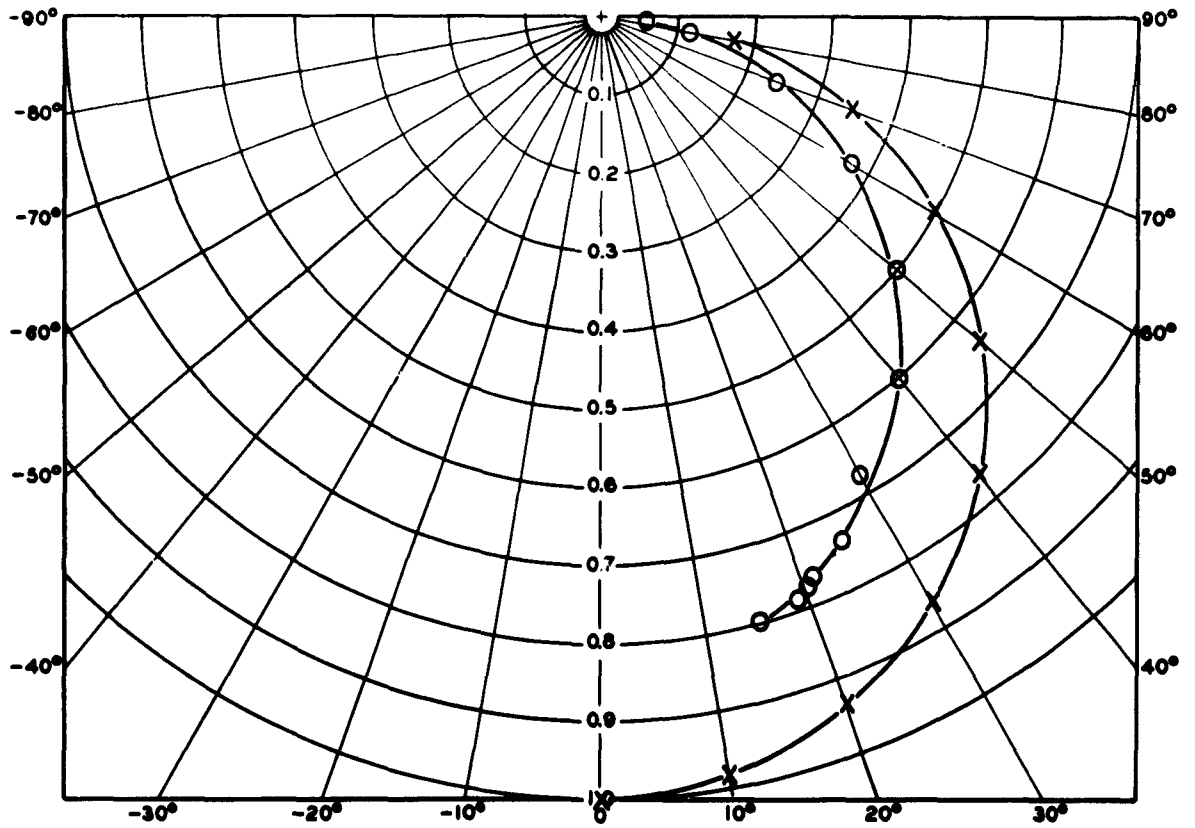

SPECTROMETER DATA

Contract AF 33(657)-9014

Record number	<u>5</u>	Incidence	<u>i=40°</u>
Type Reflection	<u>Diffuse</u>	Filter	<u>None</u>
Remarks:		Sample	<u>Diffuse Standard</u>
		Dimensions	<u>Disc. 2r=2.5cm</u>
		Coating	<u>MgO #3. t=2mm</u>
Incident Light	<u>$I_i = 0.298 \cos 40^\circ$</u>	Reference:	<u>at i=0°, r=45°</u>
Adj. Ref. for I_i	<u>1.66×10^{-7}</u>	For reflected light	<u>$I_r = 1.48 \times 10^{-7}$</u>
I'_i (adj. for ref.)	<u>0.199</u>	Filter	<u>None</u>
		b.c.	<u>1.50×10^{-9}</u>
		Lamp	<u>5.00 volts</u>
		I'_r adj.	<u>1.45×10^{-7}</u>

r	$I_r \times 10^7$ (amps)	Lamp Voltage (volts)	b.c. $\times 10^9$ (amps)	$I_r \times 10^7$ (amps)	$(I'_r / I'_i) \times 10^7$
-5°	1.61	4.98	1.53	1.59	7.99
0°	1.60	4.98	1.53	1.58	7.94
5°	1.58	4.98	1.53	1.56	7.84
10°	1.55	4.98	1.53	1.53	7.69
20°	1.45	4.98	1.53	1.43	7.19
30°	1.36	4.98	1.53	1.34	6.73
35°	1.28	4.98	1.56	1.27	6.38
40°	1.21	4.98	1.56	1.20	6.03
45°	1.11	4.98	1.56	1.10	5.53
50°	1.01	4.98	1.53	1.00	5.03
60°	0.808	5.00	1.53	0.770	3.87
70°	0.557	5.00	1.53	0.525	2.64
80°	0.300	4.99	1.53	0.276	1.39
85°	0.174	4.99	1.53	0.153	0.769

Function of the Angle of Reflection

$$f(r) = (I'_r / I'_i) \times 10^7$$

Record Number 5

○—○ $f(r)$ Measured
X—X $f(r) = \cos r$

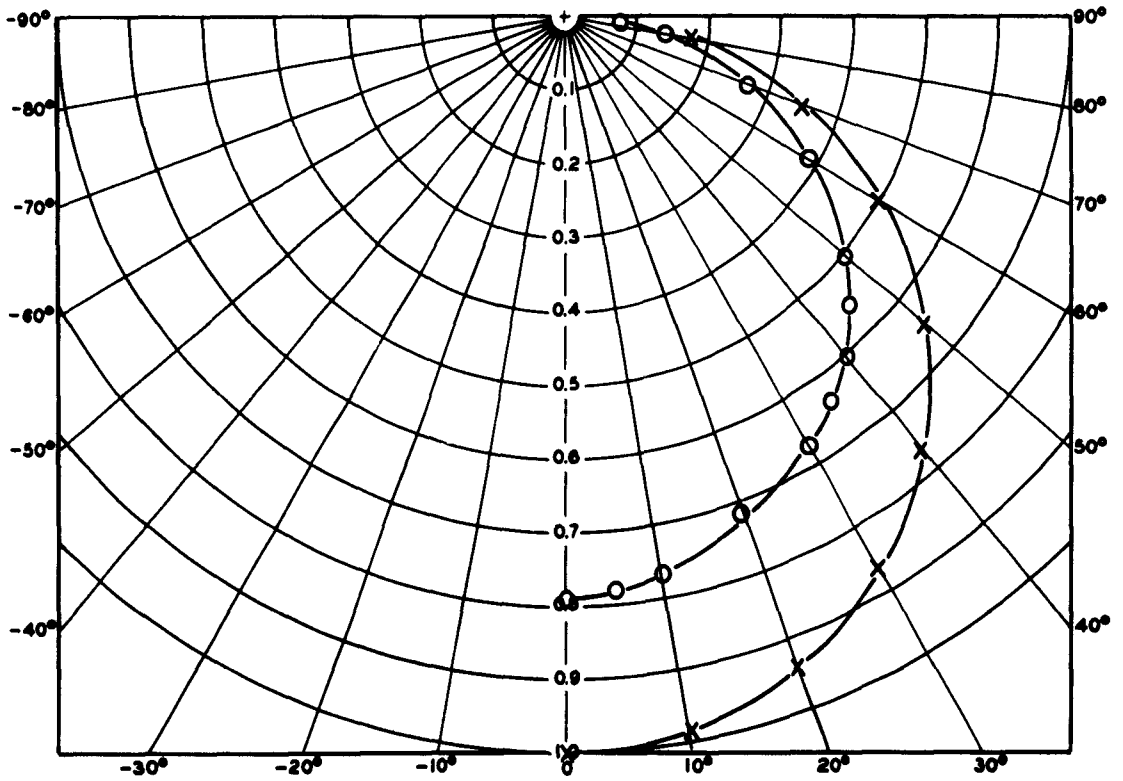

SPECTROMETER DATA

Contract AF 33(657)-9014

Record number	6	Incidence	$i=60^\circ$
Type Reflector	Diffuse	Filter	None
Remarks: report change in ref. during readings.		Sample	Diffuse Standard
		Dimensions	Disc, $2r=2.5\text{cm}$
		Coating	MgO #3, $t=2\text{mm}$
Incident Light	$I_i=0.298 \cos 60^\circ$	Reference:	at $i=0^\circ, r=45^\circ$
Adj. Ref. for I_i	1.66×10^{-7}	For reflected light	$I_r=1.32 \times 10^{-7}$
I'_i (adj. for ref.)	0.116	Filter	None
		b.c.	1.91×10^{-9}
		Lamp	4.98 volts
		I'_r adj.	1.29×10^{-7}

r	$I_r \times 10^7$ (amps)	Lamp Voltage (volts)	b.c. $\times 10^9$ (amps)	$I'_r \times 10^7$ (amps)	$(I'_r/I'_i) \times 10^7$
-25°	0.790	4.98	1.90	0.784	6.78
-15°	0.824	4.98	1.90	0.818	7.08
-5°	0.840	4.98	1.90	0.834	7.21
0°	0.840	4.98	1.90	0.834	7.21
5°	0.835	4.98	1.90	0.829	7.17
10°	0.821	4.98	1.90	0.815	7.05
20°	0.798	4.98	1.90	0.793	6.86
30°	0.748	4.98	1.90	0.742	6.42
40°	0.690	4.98	1.90	0.683	5.91
50°	0.615	4.98	1.91	0.607	5.25
55°	0.578	4.98	1.91	0.569	4.92
59°	0.535	4.98	1.91	0.525	4.54
60°	0.527	4.98	1.91	0.517	4.47
61°	0.518	4.98	1.91	0.508	4.39
65°	0.475	4.98	1.91	0.463	4.00
70°	0.418	4.98	1.91	0.405	3.50
80°	0.262	4.98	1.91	0.245	2.12
85°	0.161	4.98	1.91	0.141	1.22
87°	0.119	4.98	1.91	0.098	0.85
89°	0.078	4.97	1.91	0.057	0.49
90°	0.059	4.97	1.91	0.037	0.32

Function of the Angle of Reflection $f(r) = (I'_r/I'_i) \times 10^7$

Record Number 6

○—○ $f(r)$ Measured
X—X $f(r) = \cos r$

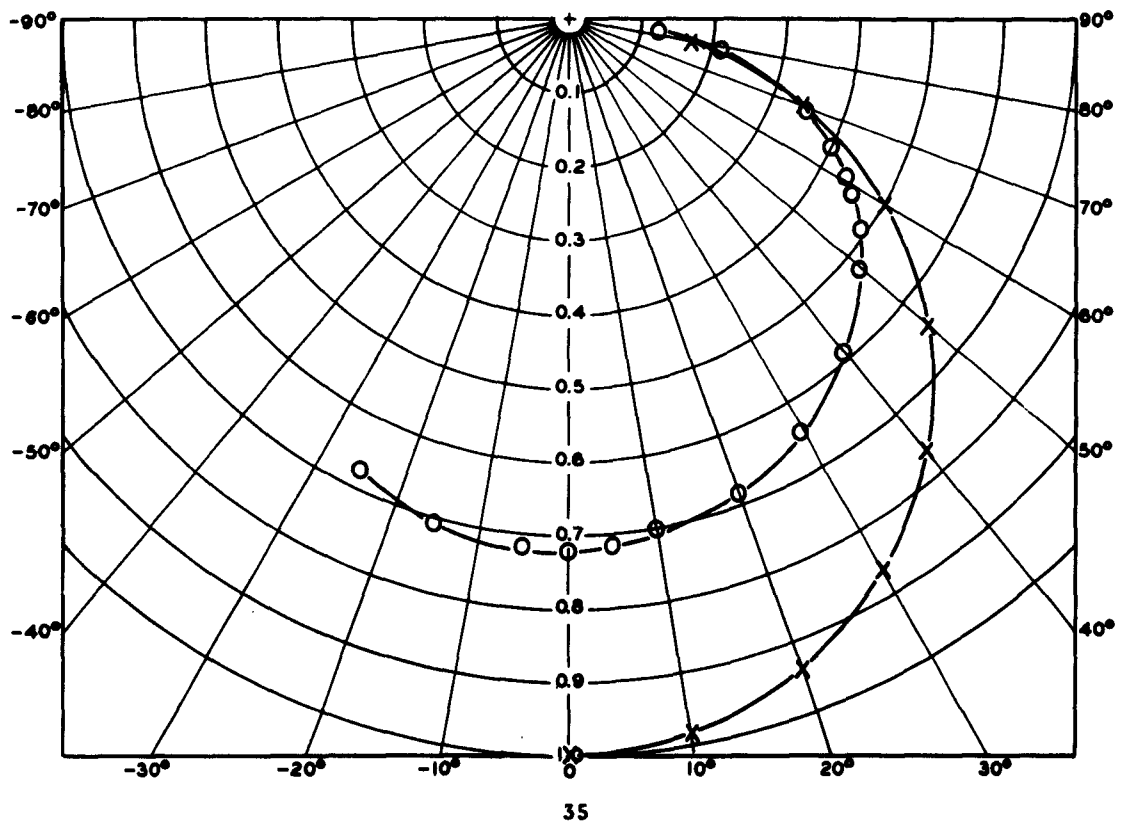

SPECTROMETER DATA

Contract AF 33(657)-9014

Record number	<u>7</u>	Incidence	<u>$i=80^\circ$</u>
Type Reflection	<u>Diffuse</u>	Filter	<u>None</u>
Remarks:	<u>Sample not perfectly plane</u>	Sample	<u>Diffuse Standard</u>
		Dimensions	<u>Disc, $2r=2.5\text{cm}$</u>
		Coating	<u>MgO #3, $t=2\text{mm}$</u>

Incident Light	<u>$I_i=0.298 \cos 80^\circ$</u>
Adj. Ref. for I_i	<u>1.66×10^{-7}</u>
I'_i (adj. for ref.)	<u>0.0484</u>

Reference:	<u>at $i=0^\circ, r=45^\circ$</u>
For reflected light	<u>$I_r=1.62 \times 10^{-7}$</u>
Filter	<u>None</u>
b.c.	<u>2.31×10^{-9}</u>
Lamp	<u>5.00 volts</u>
I'_r adj.	<u>1.55×10^{-7}</u>

r	$I_r \times 10^7$ (amps)	Lamp Voltage (volts)	b.c. $\times 10^9$ (amps)	$I'_r \times 10^7$ (amps)	$(I'_r / I_i) \times 10^7$
-45°	0.296	5.00	2.33		
-40°	0.310	5.01	2.33		
-30°	0.323	5.00	2.33		
-20°	0.331	5.00	2.33		
-10°	0.335	5.00	2.34		
0°	0.330	5.00	2.34	0.304	6.28
10°	0.327	5.00	2.34	0.301	6.22
20°	0.321	5.00	2.34	0.295	6.10
30°	0.315	5.00	2.34	0.289	5.97
40°	0.307	5.00	2.33	0.281	5.81
50°	0.301	5.00	2.33	0.275	5.68
60°	0.298	5.00	2.33	0.271	5.60
70°	0.286	5.00	2.33	0.258	5.33

Function of the Angle of Reflection $f(r) = (I'_r/I'_i) \times 10^7$

Record Number 7

○—○ $f(r)$ Measured
X—X $f(r) = \cos r$

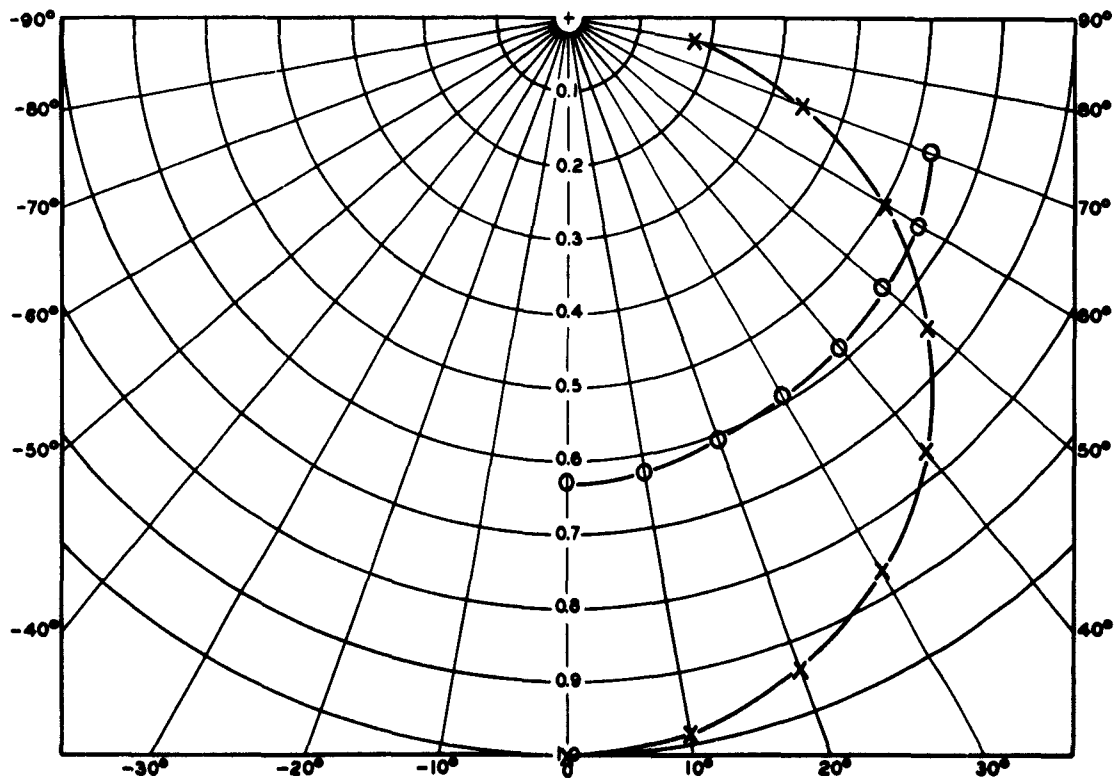

SPECTROMETER DATA

Contract AF 33(657)-9014

Record number	<u>8</u>	Incidence	<u>i=0°</u>
Type Reflection	<u>Diffuse</u>	Filter	<u>O.T. #436 blue</u>
Remarks: Ref. for I_r without filter		Sample	<u>Diffuse Standard</u>
1.76×10^{-7}		Dimensions	<u>Disc. 2r=2.5cm</u>
		Coating	<u>MgO #3. t=2mm</u>
Incident Light	<u>$I_i=0.00640$</u>	Reference:	<u>at i=0°, r=45°</u>
Adj. Ref. for I_i	<u>1.66×10^{-7}</u>	For reflected light	<u>$I_r=0.0593 \times 10^{-7}$</u>
I'_i (adj. for ref.)	<u>0.00679</u>	Filter	<u>O.T. #436 blue</u>
		b.c.	<u>2.28×10^{-9}</u>
		Lamp	<u>5.00 volts</u>
		I'_r adj.	<u>0.0378×10^{-7}</u>

r	$I_r \times 10^7$ (amps)	Lamp Voltage (volts)	b.c. $\times 10^9$ (amps)	$I'_r \times 10^7$ (amps)	$(I'_r / I'_i) \times 10^7$
40°	0.0633	4.99	2.28	0.0390	5.75
45°	0.0593	4.99	2.28	0.0351	5.17
50°	0.0559	4.99	2.26	0.0316	4.65
60°	0.0473	4.99	2.28	0.0227	3.34
70°	0.0388	4.98	2.28	0.0146	2.15
80°	0.0302	4.98	2.26	0.0057	0.84
85°	0.0264	4.98	2.26	0.0018	0.27
40°	0.0630	4.99	2.26	0.0017	0.25
-40° *	0.0650	4.98	2.43		
-50° *	0.0570	4.98	2.43		
-60° *	0.0492	4.98	2.43		
-70° *	0.0412	4.98	2.43		
-80° *	0.0319	4.98	2.43		

* New Reference $I_r=0.0383 \times 10^{-7}$ at i=0°, r=45°

Function of the Angle of Reflection $f(r) = (I'_r/I'_i) \times 10^7$

Record Number 8

○—○ $f(r)$ Measured
X—X $f(r) = \cos r$

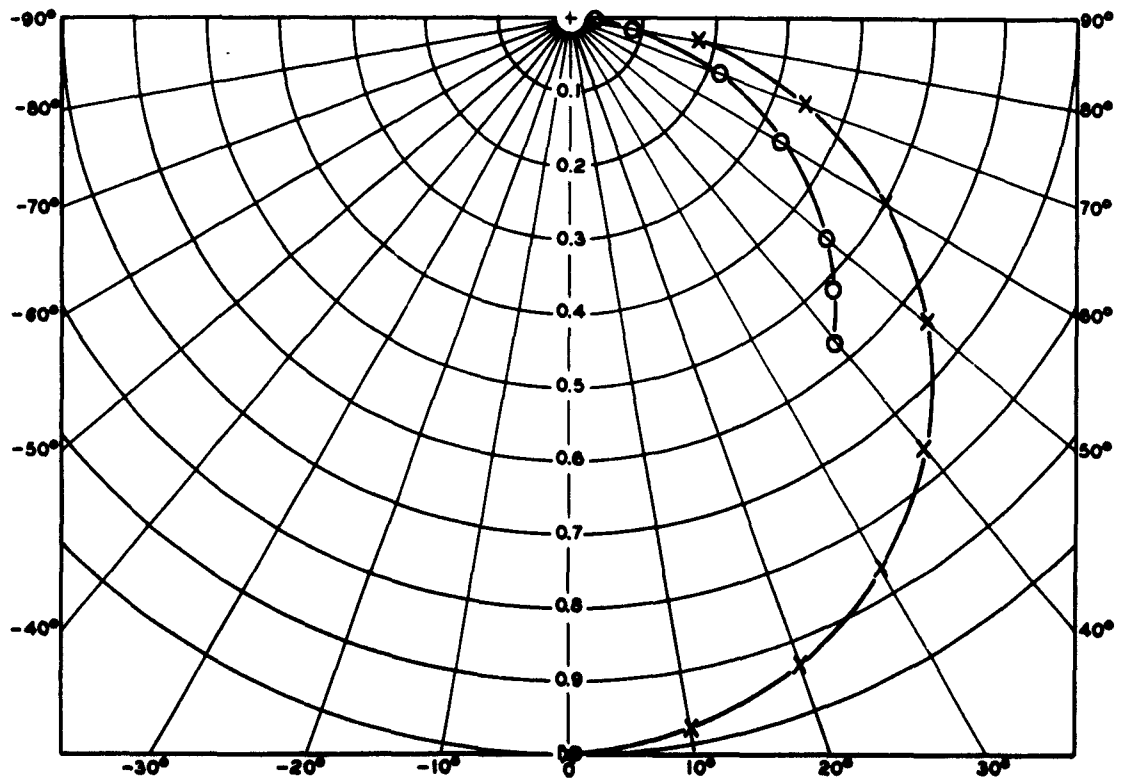

SPECTROMETER DATA

Contract AF 33(657)-9014

Record number 9 Incidence $i=20^\circ$
 Filter O.T. #436 blue
 Type Reflection Diffuse Sample Diffuse Standard
 Remarks: Changed setting before second Dimensions Disc. $2r=2.5\text{cm}$
20° reading Coating MgO #3, $t=2\text{mm}$

Incident Light 0.00602 Reference: at $i=0^\circ$, $r=45^\circ$
 Adj. Ref. for I_i 1.66×10^{-7} For reflected light $I_r=0.0607 \times 10^{-7}$
 I'_i (adj. for ref.) 0.00643 Filter O.T. #436 blue
 b.c. 2.33×10^{-9}
 Lamp 5.00 volts
 I'_r adj. 0.0381×10^{-7}

r	$I_r \times 10^7$ (amps)	Lamp Voltage (volts)	b.c. $\times 10^9$ (amps)	$I'_r \times 10^7$ (amps)	$(I'_r/I'_i) \times 10^7$
20°	0.0700	4.98	2.33	0.0461	7.17
30°	0.0660	4.98	2.33	0.0420	6.53
40°	0.0608	4.98	2.33	0.0367	5.71
50°	0.0540	4.98	2.35	0.0298	4.63
60°	0.0467	4.98	2.35	0.0221	3.44
70°	0.0388	4.98	2.35	0.0142	2.21
80°	0.0312	4.98	2.37	0.0060	0.93
85°	0.0278	4.99	2.37	0.0023	0.36
20°	0.0710	5.00	2.40		

Function of the Angle of Reflection $f(r) = (I'_r / I'_i) \times 10^7$

Record Number 9

○—○ $f(r)$ Measured
 X—X $f(r) = \cos r$

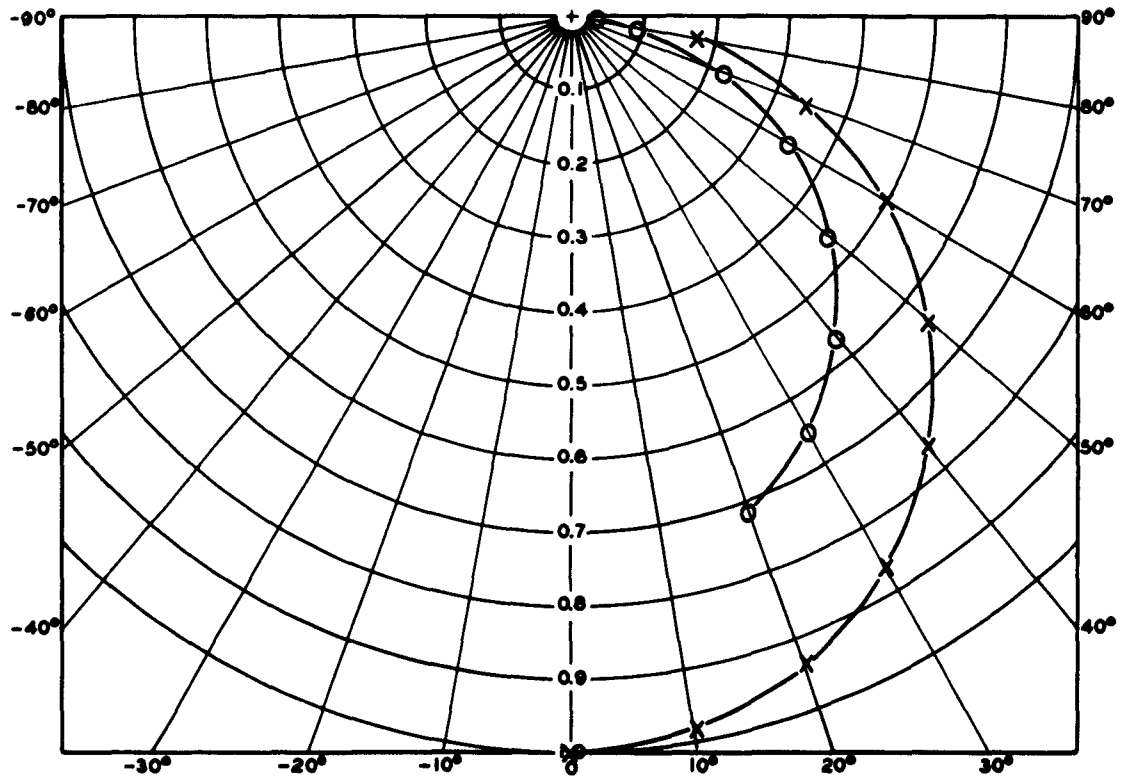

SPECTROMETER DATA

Contract AF 33(657)-9014

Record number	<u>10</u>	Incidence	<u>i=40°</u>
Type Reflection	<u>Diffuse</u>	Filter	<u>O.T. #436 blue</u>
Remarks:		Sample	<u>Diffuse Standard</u>
		Dimensions	<u>Disc, 2r=2.5cm</u>
		Coating	<u>MgO #3, t=2mm</u>
Incident Light	<u>I_i=0.00490</u>	Reference:	<u>at i=0°, r=45°</u>
Adj. Ref. for I _i	<u>1.66 x 10⁻⁷</u>	For reflected light	<u>I_r=0.0607 x 10⁻⁷</u>
I' _i (adj. for ref.)	<u>0.00530</u>	Filter	<u>O.T. #436 blue</u>
		b.c.	<u>2.40 x 10⁻⁹</u>
		Lamp	<u>4.98 volts</u>
		I' _r adj.	<u>0.0386 x 10⁻⁷</u>

r	I _r x 10 ⁷ (amps)	Lamp Voltage (volts)	b.c. x 10 ⁹ (amps)	I' _r x 10 ⁷ (amps)	(I' _r /I' _i) x 10 ⁷
0°	0.0640	5.00	2.43	0.0373	7.04
10°	0.0632	4.99	2.43	0.0367	6.92
20°	0.0607	4.99	2.44	0.0348	6.57
30°	0.0585	4.99	2.44	0.0328	6.19
40°	0.0540	4.99	2.44	0.0282	5.32
50°	0.0500	4.99	2.45	0.0243	4.58
60°	0.0446	4.99	2.44	0.0187	3.53
70°	0.0385	4.99	2.44	0.0125	2.36
80°	0.0308	4.99	2.44	0.0046	0.87
0°	0.0640	4.99			

Function of the Angle of Reflection $f(r) = (I'_R/I'_I) \times 10^7$

Record Number 10

○—○ $f(r)$ Measured
X—X $f(r) = \cos r$

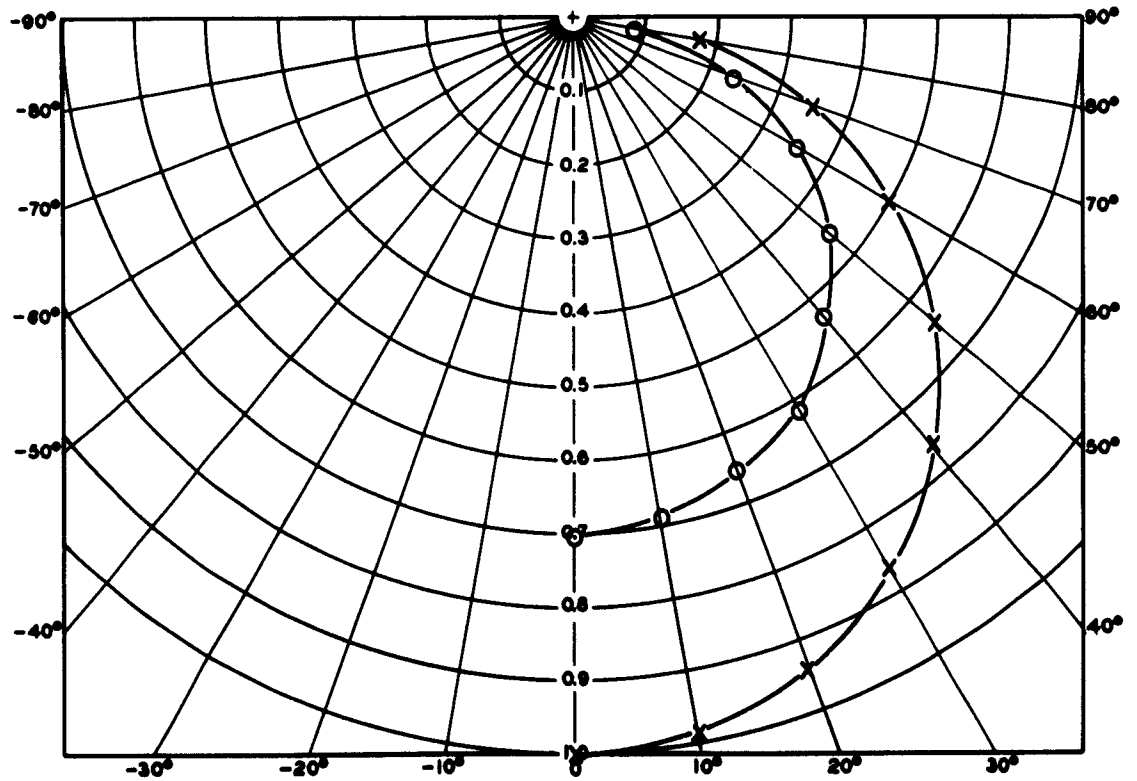

SPECTROMETER DATA

Contract AF 33(657)-9014

Record number	<u>11</u>	Incidence	<u>$i=60^\circ$</u>
Type Reflection	<u>Diffuse</u>	Filter	<u>O.T. #436 blue</u>
Remarks:	<u></u>	Sample	<u>Diffuse Standard</u>
	<u></u>	Dimensions	<u>Disc. $2r=2.5cm$</u>
	<u></u>	Coating	<u>MoO #3. $t=2mm$</u>
Incident Light	<u>$I_i=0.00320$</u>	Reference:	<u>at $i=0^\circ, r=45^\circ$</u>
Adj. Ref. for I_i	<u>1.66×10^{-7}</u>	For reflected light	<u>$I_r=0.0607 \times 10^{-7}$</u>
I'_i (adj. for ref.)	<u>0.00344</u>	Filter	<u>O.T. #436 blue</u>
		b.c.	<u>2.43×10^{-9}</u>
		Lamp	<u>4.98 volts</u>
		I'_r adj.	<u>0.0383×10^{-7}</u>

r	$I_r \times 10^7$ (amps)	Lamp Voltage (volts)	b.c. $\times 10^9$ (amps)	$I'_r \times 10^7$ (amps)	$(I'_r / I'_i) \times 10^7$
-20°	0.0470	4.98	2.43		
-10°	0.0478	4.98	2.42		
0°	0.0476	4.99	2.41	0.0216	6.28
10°	0.0470	4.99	2.40	0.0212	6.16
20°	0.0461	4.99	2.40	0.0204	5.93
30°	0.0456	4.99	2.40	0.0201	5.84
40°	0.0437	4.99	2.40	0.0182	5.29
50°	0.0412	4.99	2.40	0.0156	4.53
60°	0.0387	4.99	2.40	0.0131	3.81
70°	0.0358	4.99	2.40	0.0096	2.79
80°	0.0312	4.99	2.41	0.0043	1.25
-20°	0.0470	4.98	2.41		

Function of the Angle of Reflection $f(r) = (I'_r / I'_i) \times 10^7$

Record Number 11
O—O $f(r)$ Measured
X—X $f(r) = \cos r$

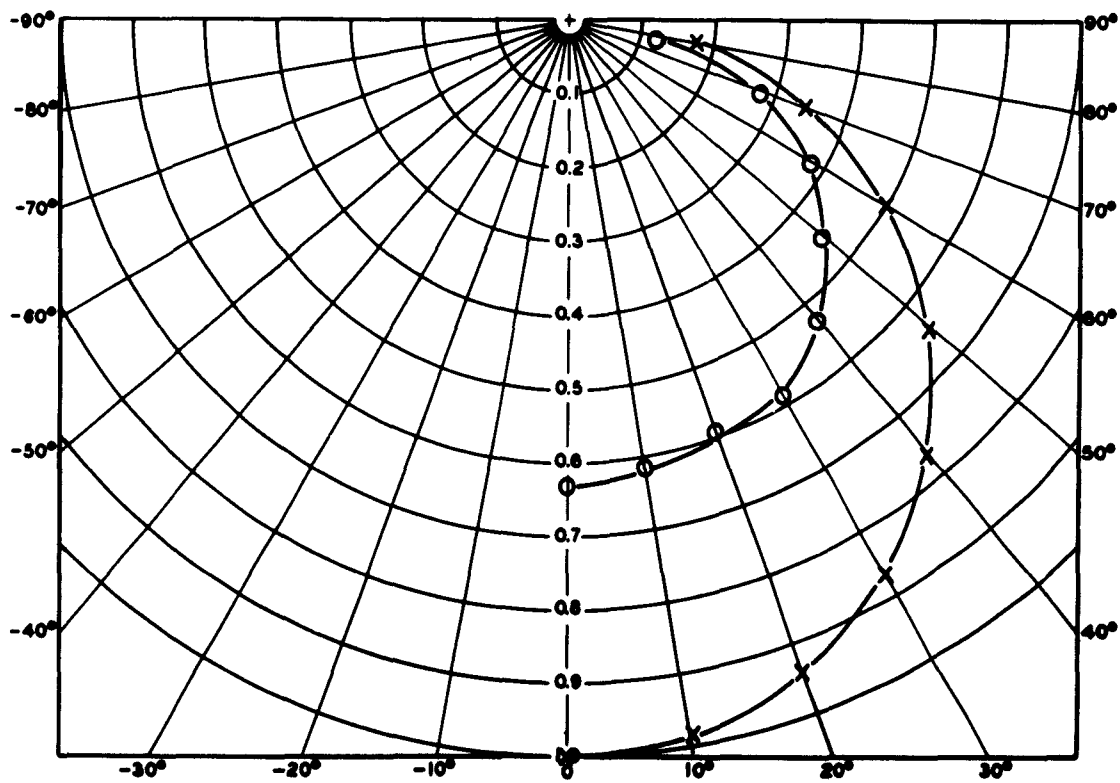

SPECTROMETER DATA

Contract AF 33(657)-9014

Record number	<u>12</u>	Incidence	<u>$i=80^\circ$</u>
Type Reflection	<u>Diffuse</u>	Filter	<u>O.T. #436 blue</u>
Remarks:		Sample	<u>Diffuse Standard</u>
		Dimensions	<u>Disc, $2r=2.5\text{cm}$</u>
		Coating	<u>Mgo #3, $t=2\text{mm}$</u>

Incident Light	<u>$I_i=0.00111$</u>
Adj. Ref. for I_i	<u>1.66×10^{-7}</u>
I'_i (adj. for ref.)	<u>0.00120</u>

Reference:	<u>at $i=0^\circ, r=45^\circ$</u>
For reflected light	<u>$I_r=0.0607 \times 10^{-7}$</u>
Filter	<u>O.T. #436 blue</u>
b.c.	<u>2.43×10^{-9}</u>
Lamp	<u>4.98 volts</u>
I'_r adj.	<u>0.0383×10^{-7}</u>

r	$I_r \times 10^7$ (amps)	Lamp Voltage (volts)	b.c. $\times 10^9$ (amps)	$I'_r \times 10^7$ (amps)	$(I'_r / I_i) \times 10^7$
-40°	0.0304	4.98	2.41		
0°	0.0308	4.98	2.40	0.0050	4.17
40°	0.0306	4.98	2.40	0.0051	4.25
70°	0.0303	4.98	2.40	0.0027	2.25
80°	0.0295	4.98	2.40	0.0017	1.42

Function of the Angle of Reflection $f(r) = (I'_r / I'_i) \times 10^7$

Record Number 12

O—O $f(r)$ Measured
X—X $f(r) = \cos r$

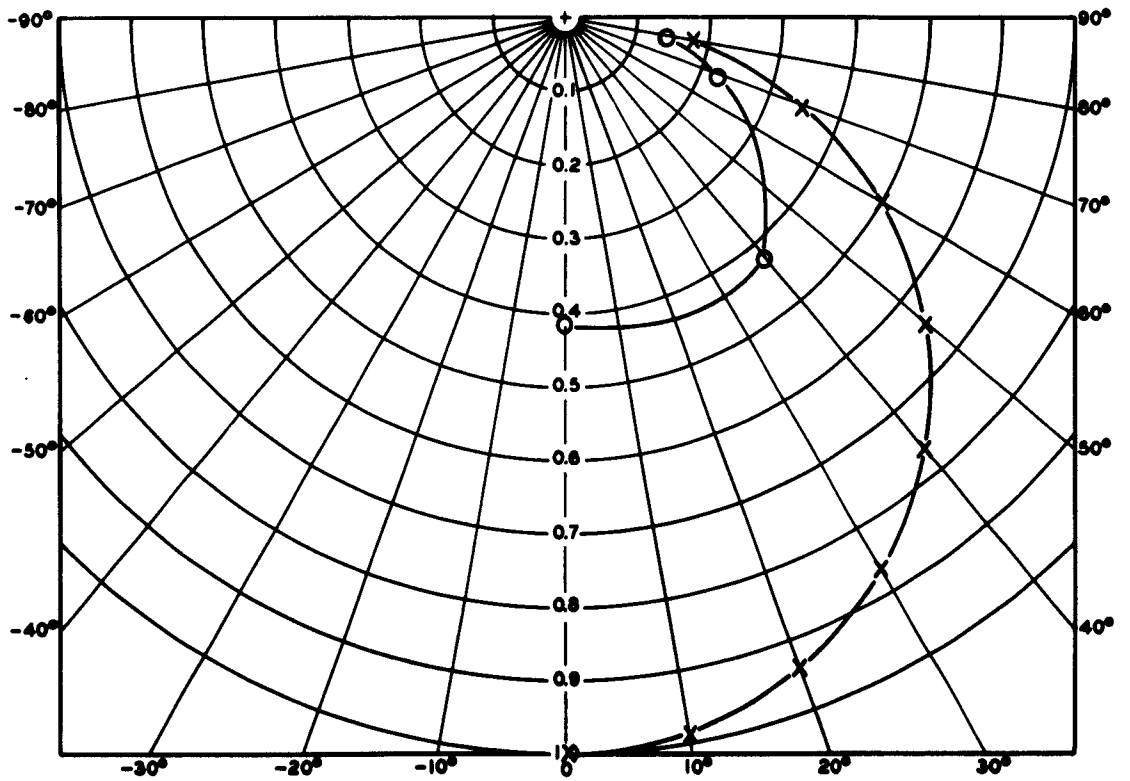

SPECTROMETER DATA

Contract AF 33(657)-9014

Record number	<u>13</u>	Incidence	<u>i=0°</u>
Type Reflection	<u>Diffuse</u>	Filter	<u>O.T. #546 green</u>
Remarks: <u>Ref. for I_r without filter</u>		Sample	<u>Diffuse Standard</u>
<u>1.73 x 10⁻⁷</u>		Dimensions	<u>Disc. 2r=2.5cm</u>
		Coating	<u>MgO #3, t=2mm</u>
Incident Light	<u>I_i=0.0138</u>	Reference:	<u>at i=0°, r=45°</u>
Adj. Ref. for I _i	<u>1.66 x 10⁻⁷</u>	For reflected light	<u>I_r=0.104 x 10⁻⁷</u>
I _i (adj. for ref.)	<u>0.0144</u>	Filter	<u>O.T. #546 green</u>
		b.c.	<u>2.33 x 10⁻⁹</u>
		Lamp	<u>5.00 volts</u>
		I _r adj.	<u>0.080 x 10⁻⁷</u>

r	I _r x10 ⁷ (amps)	Lamp Voltage(volts)	b.c.x10 ⁹ (amps)	I _r 'x10 ⁷ (amps)	(I _r '/I _i)x10 ⁷
45°	0.104	5.00	2.24	0.078	5.42
40°	0.109	5.00	2.24	0.083	5.76
50°	0.0933	5.00	2.24	0.0696	4.83
60°	0.0758	5.00	2.24	0.0517	3.59
70°	0.0562	5.01	2.24	0.0313	2.17
80°	0.0390	5.01	2.24	0.0141	0.98
85°	0.0312	5.01	2.24	0.0063	0.44
40°	0.109	5.00	2.24	0.083	5.76
-40°	0.109	5.01	2.23		
-50°	0.0923	5.02	2.23		
-60°	0.0729	5.00	2.23		
-70°	0.0548	5.00	2.23		
-80°	0.0380	5.00	2.23		
-85°	0.0302	5.00	2.23		
-40°	0.108	5.00	2.23		

Function of the Angle of Reflection $f(r) = (I'_r / I'_i) \times 10^7$

Record Number 13

○—○ $f(r)$ Measured
 X—X $f(r) = \cos r$

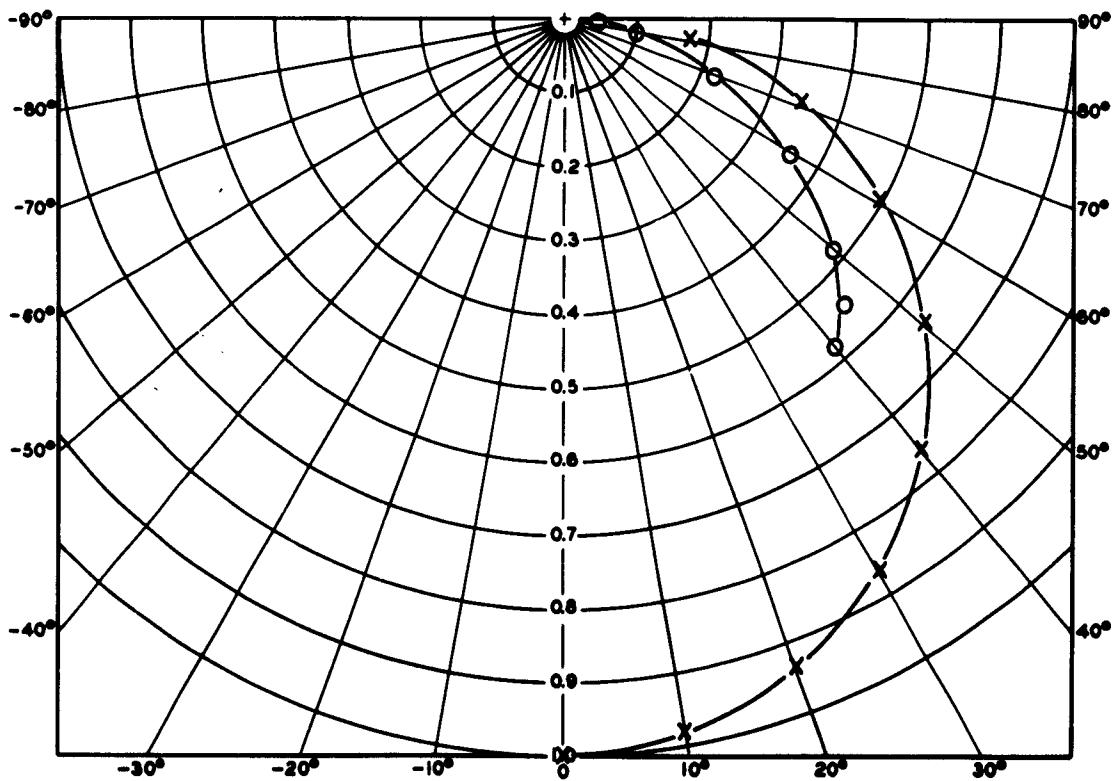

SPECTROMETER DATA

Contract AF 33(657)-9014

Record number	<u>14</u>	Incidence	<u>$i=20^\circ$</u>
Type Reflection	<u>Diffuse</u>	Filter	<u>O.T. #546 green</u>
Remarks:	<u></u>	Sample	<u>Diffuse Standard</u>
	<u></u>	Dimensions	<u>Disc, $2r=2.5\text{cm}$</u>
	<u></u>	Coating	<u>MgO #3, $t=2\text{mm}$</u>

Incident Light	<u>$I_i=0.0130$</u>
Adj. Ref. for I_i	<u>1.66×10^{-7}</u>
I'_i (adj. for ref.)	<u>0.0138</u>

Reference:	<u>at $i=0^\circ$, $r=45^\circ$</u>
For reflected light	<u>$I_r=0.104 \times 10^{-7}$</u>
Filter	<u>O.T. #546 green</u>
b.c.	<u>2.25×10^{-9}</u>
Lamp	<u>4.99 volts</u>
I'_r adj.	<u>0.082×10^{-7}</u>

r	$I_r \times 10^7$ (amps)	Lamp Voltage (volts)	b.c. $\times 10^9$ (amps)	$I'_r \times 10^7$ (amps)	$(I'_r / I'_i) \times 10^7$
20°	0.126	5.00	2.26	0.100	7.25
30°	0.116	5.00	2.26	0.090	6.52
40°	0.104	4.99	2.26	0.079	5.72
50°	0.091	4.99	2.26	0.066	4.78
60°	0.074	4.99	2.26	0.050	3.62
70°	0.0552	4.98	2.26	0.0321	2.33
80°	0.0386	4.98	2.26	0.0148	1.07
20°	0.125	4.98	2.26		

Function of the Angle of Reflection $f(r) = (I'_r / I'_i) \times 10^7$

Record Number 14

○—○ $f(r)$ Measured

X—X $f(r) = \cos r$

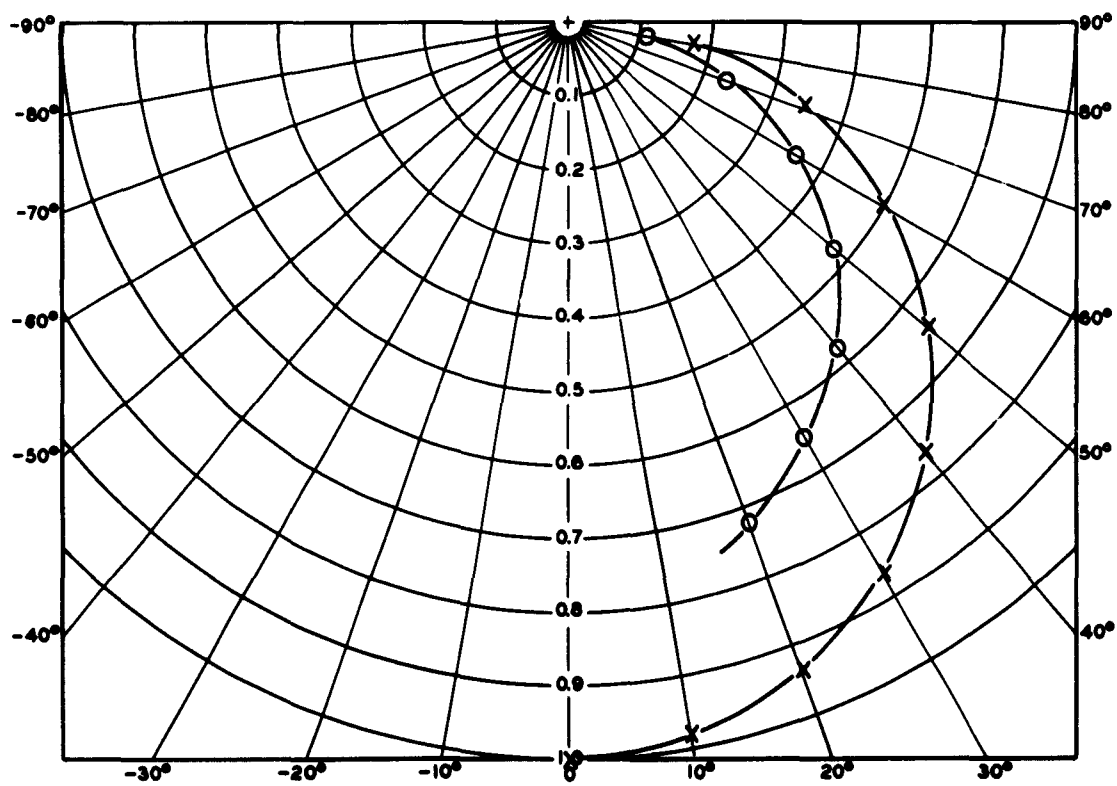

SPECTROMETER DATA

Contract AF 33(657)-9014

Record number	<u>15</u>	Incidence	<u>$i=40^\circ$</u>
Type Reflection	<u>Diffuse</u>	Filter	<u>O.T. #546 green</u>
Remarks:		Sample	<u>Diffuse Standard</u>
		Dimensions	<u>Disc. $2r=2.5\text{cm}$</u>
		Coating	<u>MgO #3. $t=2\text{mm}$</u>
Incident Light	<u>$I_i=0.0106$</u>	Reference:	<u>at $i=0^\circ$, $r=45^\circ$</u>
Adj. Ref. for I_i	<u>1.66×10^{-7}</u>	For reflected light	<u>$I_r=0.102 \times 10^{-7}$</u>
I'_i (adj. for ref.)	<u>0.0111</u>	Filter	<u>O.T. #546 green</u>
		b.c.	<u>2.20×10^{-9}</u>
		Lamp	<u>4.98 volts</u>
		I'_r adj.	<u>0.081×10^{-7}</u>

r	$I_r \times 10^7$ (amps)	Lamp Voltage (volts)	b.c. $\times 10^9$ (amps)	$I'_r \times 10^7$ (amps)	$(I'_r/I'_i) \times 10^7$
0°	0.111	5.00	2.21	0.086	7.75
10°	0.108	5.00	2.21	0.083	7.48
20°	0.103	5.00	2.21	0.078	7.03
30°	0.097	4.99	2.21	0.073	6.58
40°	0.088	4.98	2.21	0.065	5.86
50°	0.0767	4.99	2.22	0.0539	4.86
60°	0.0659	5.02	2.23	0.0408	3.68
70°	0.0521	5.00	2.24	0.0281	2.53
80°	0.0379	5.00	2.25	0.0137	1.23
0°	0.111	5.00			

Function of the Angle of Reflection $f(r) = (I'_r/I'_i) \times 10^7$

Record Number 15

○—○ $f(r)$ Measured
 X—X $f(r) = \cos r$

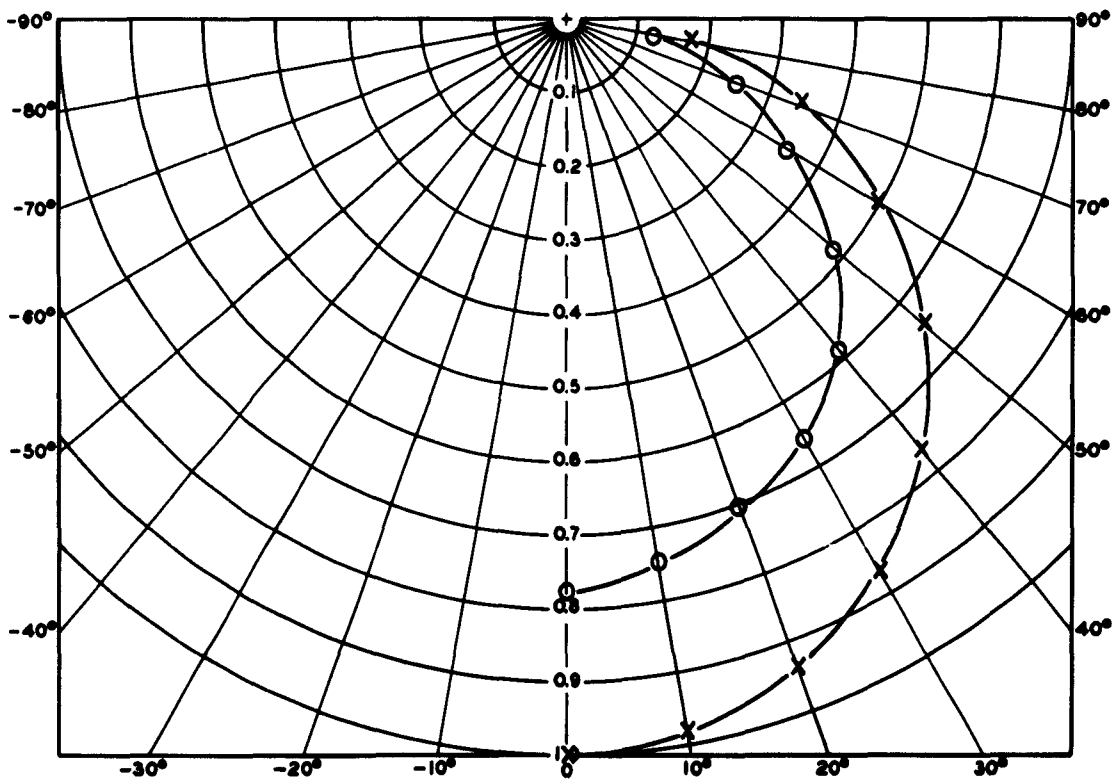

SPECTROMETER DATA

Contract AF 33(657)-9014

Record number	<u>16</u>	Incidence	<u>i=60°</u>
Type Reflection	<u>Diffuse</u>	Filter	<u>O.T. #546 green</u>
Remarks:		Sample	<u>Diffuse Standard</u>
		Dimensions	<u>Disc, 2r=2.5cm</u>
		Coating	<u>MgO #3, t=2mm</u>

Incident Light	<u>I_i=0.00689</u>
Adj. Ref. for I _i	<u>1.66 x 10⁻⁷</u>
I _i (adj. for ref.)	<u>0.00709</u>

Reference:	<u>at i=0°, r=45°</u>
For reflected light	<u>I_r=0.103 x 10⁻⁷</u>
Filter	<u>O.T. #546 green</u>
b.c.	<u>2.32 x 10⁻⁹</u>
Lamp	<u>5.00 volts</u>
I _r adj.	<u>0.079 x 10⁻⁷</u>

r	I _r x 10 ⁷ (amps)	Lamp Voltage (volts)	b.c. x 10 ⁹ (amps)	I _r ' x 10 ⁷ (amps)	(I _r ' / I _i ') x 10 ⁷
---	---	----------------------	-------------------------------	---	---

-20°	0.0725	5.00	2.25		
-10°	0.0738	5.00	2.25		
0°	0.0738	5.00	2.25	0.0496	6.99
10°	0.0735	5.00	2.25	0.0495	6.98
20°	0.0710	5.00	2.25	0.0471	6.64
30°	0.0681	5.00	2.25	0.0443	6.25
40°	0.0642	4.99	2.25	0.0410	5.78
50°	0.0598	4.99	2.25	0.0365	5.15
60°	0.0538	4.99	2.25	0.0303	4.27
70°	0.0466	4.99	2.25	0.0224	3.16
80°	0.0377	4.98	2.25	0.0132	1.86
-20°	0.0720	4.98	2.25		

Function of the Angle of Reflection $f(r) = (I'_r / I'_i) \times 10^7$

Record Number 16

O—O $f(r)$ Measured
X—X $f(r) = \cos r$

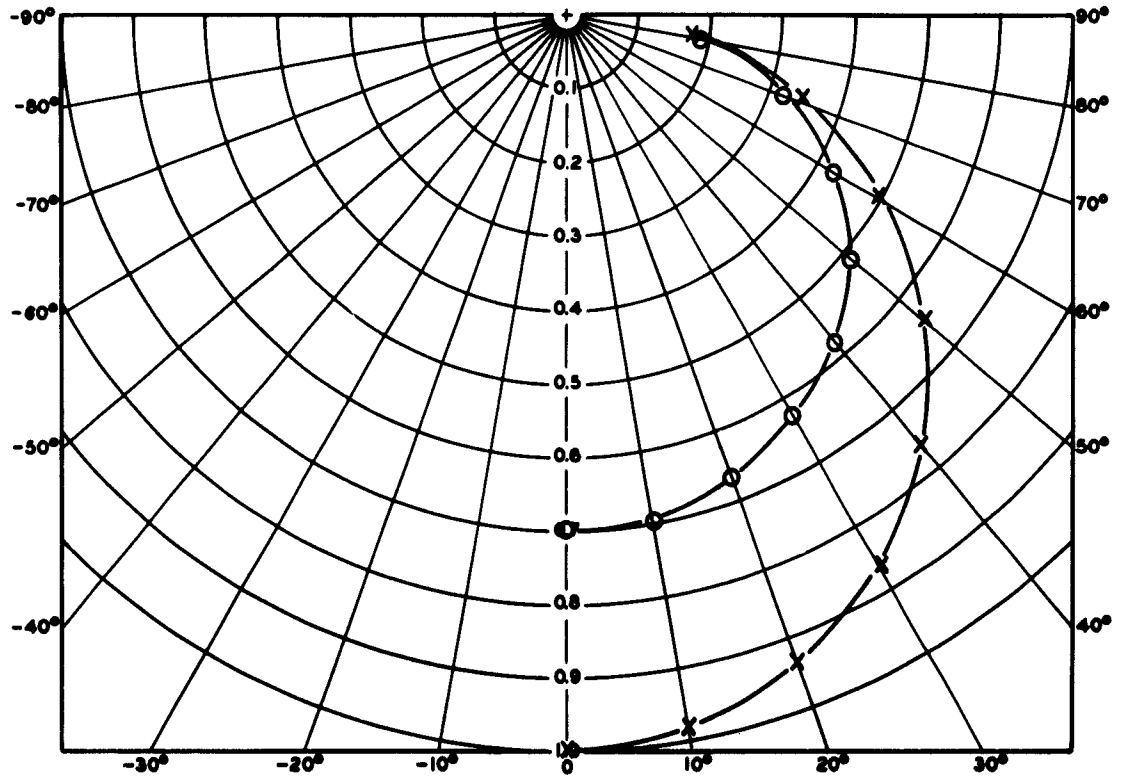

SPECTROMETER DATA

Contract AF 33(657)-9014

Record number	<u>17</u>	Incidence	<u>$i=80^\circ$</u>
Type Reflection	<u>Diffuse</u>	Filter	<u>O.T. #546 green</u>
Remarks:		Sample	<u>Diffuse Standard</u>
		Dimensions	<u>Disc. 2r=2.5cm</u>
		Coating	<u>MgO #3, t=2mm</u>
Incident Light	<u>$I_i=0.00240$</u>	Reference:	<u>at $i=0^\circ, r=45^\circ$</u>
Adj. Ref. for I_i	<u>1.66×10^{-7}</u>	For reflected light	<u>$I_r=0.105 \times 10^{-7}$</u>
I'_i (adj. for ref.)	<u>0.00256</u>	Filter	<u>O.T. #546 green</u>
		b.c.	<u>2.28×10^{-9}</u>
		Lamp	<u>5.00 volts</u>
		I'_r adj.	<u>0.082×10^{-7}</u>

r	$I_r \times 10^7$ (amps)	Lamp Voltage (volts)	b.c. $\times 10^9$ (amps)	$I'_r \times 10^7$ (amps)	$(I'_r/I'_i) \times 10^7$
-40°	0.0374	5.00	2.28		
-20°	0.0382	5.00	2.29		
0°	0.0382	5.00	2.32	0.0128	4.99
20°	0.0379	5.00	2.32	0.0127	4.95
40°	0.0368	5.00	2.32	0.0117	4.56
60°	0.0365	5.00	2.32	0.0104	4.06

Function of the Angle of Reflection $f(r) = (I'_r / I'_i) \times 10^7$

Record Number 17

○ — ○ $f(r)$ Measured
X — X $f(r) = \cos r$

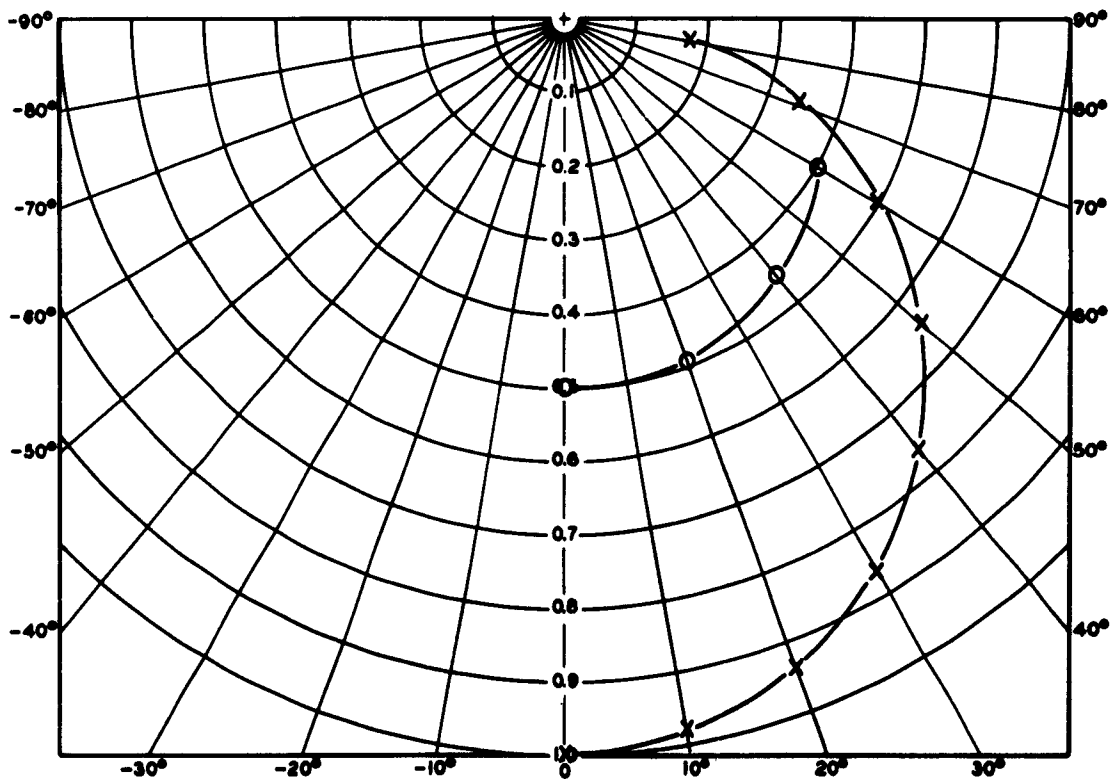

SPECTROMETER DATA

Contract AF 33(657)-9014

Record number	<u>18</u>	Incidence	<u>$i=0^\circ$</u>
Type Reflection	<u>Diffuse</u>	Filter	<u>O.T. #656 red</u>
Remarks: Ref. for I_r without filter	<u>1.75×10^{-7}</u>	Sample	<u>Diffuse Standard</u>
		Dimensions	<u>Disc, $2r=2.5\text{cm}$</u>
		Coating	<u>MgO #3, $t=2\text{mm}$</u>
Incident Light	<u>$I_i=0.00460$</u>	Reference:	<u>at $i=0^\circ$, $r=45^\circ$</u>
Adj. Ref. for I_i	<u>1.66×10^{-7}</u>	For reflected light	<u>$I_r=0.0485 \times 10^{-7}$</u>
I'_i (adj. for ref.)	<u>0.00485</u>	Filter	<u>O.T. #656 red</u>
		b.c.	<u>2.31×10^{-9}</u>
		Lamp	<u>4.98 volts</u>
		I'_r adj.	<u>0.0270×10^{-7}</u>

r	$I_r \times 10^7$ (amps)	Lamp Voltage (volts)	b.c. $\times 10^9$ (amps)	$I'_r \times 10^7$ (amps)	$(I'_r / I'_i) \times 10^7$
40°	0.0520	5.00	2.32	0.0263	5.42
45°	0.0485	4.97	2.32	0.0245	5.05
50°	0.0461	4.98	2.32	0.0214	4.41
60°	0.0406	4.98	2.32	0.0157	3.24
70°	0.0345	4.98	2.32	0.0096	1.98
40°	0.0518	4.98	2.32		

Function of the Angle of Reflection $f(r) = (I'_r / I'_i) \times 10^7$

Record Number 18

O—O $f(r)$ Measured
X—X $f(r) = \cos r$

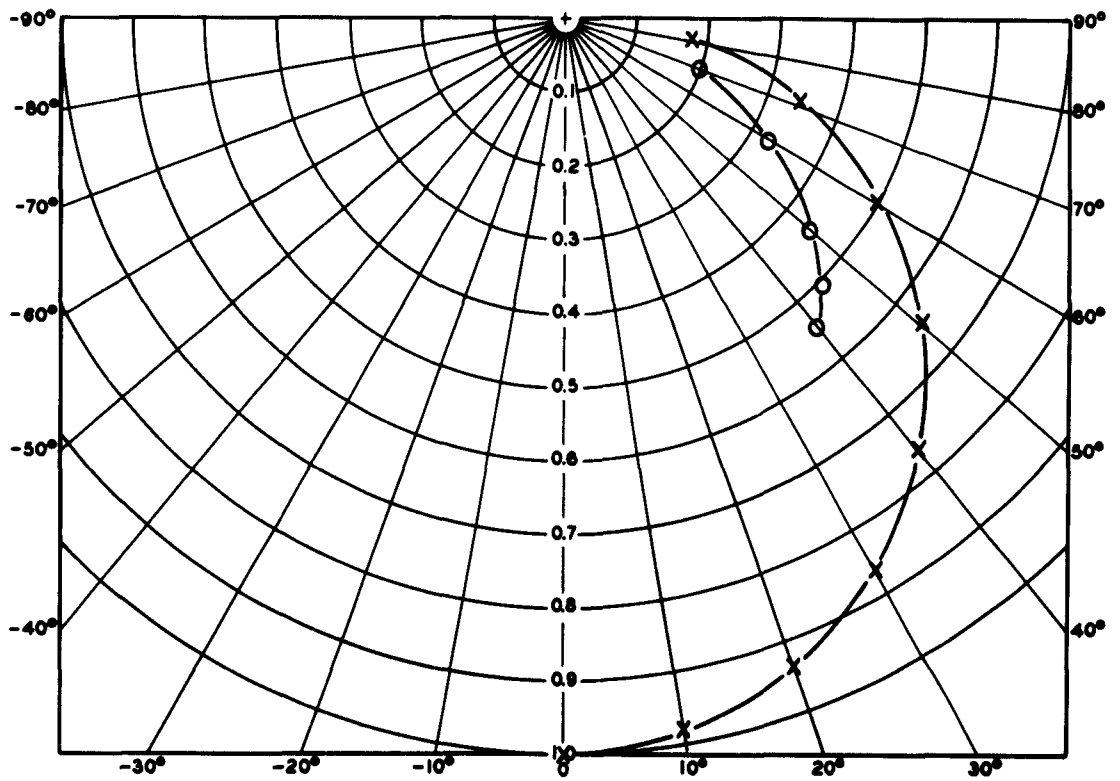

SPECTROMETER DATA

Contract AF 33(657)-9014

Record number	<u>19</u>	Incidence	<u>i=20°</u>
Type Reflection	<u>Diffuse</u>	Filter	<u>O.T. #656 red</u>
Remarks:		Sample	<u>Diffuse Standard</u>
		Dimensions	<u>Disc. 2r=2.5cm</u>
		Coating	<u>MgO #3, t=2mm</u>

Incident Light I_i=0.00432
 Adj. Ref. for I_i 1.66 x 10⁻⁷
 I'_i (adj. for ref.) 0.00442

Reference: at i=0°, r=45°
 For reflected light I_r=0.0502 x 10⁻⁷
 Filter O.T. #656 red
 b.c. 2.45 x 10⁻⁹
 Lamp 5.00 volts
 I'_r adj. 0.0262 x 10⁻⁷

r	I _r x10 ⁷ (amps)	Lamp Voltage(volts)	b.c.x10 ⁹ (amps)	I' _r x10 ⁷ (amps)	(I' _r /I' _i)x10 ⁷
20°	0.0573	4.98	2.45	0.0316	7.15
30°	0.0542	5.00	2.42	0.0278	6.29
40°	0.0501	5.01	2.42	0.0231	5.23
50°	0.0460	5.01	2.42	0.0191	4.32
60°	0.0403	5.01	2.42	0.0135	3.05
70°	0.0352	5.01	2.41	0.0086	1.95
80°	0.0294	4.99	2.41	0.0034	0.77
20°	0.0573	5.00	2.41		

Function of the Angle of Reflection $f(r) = (I'_r / I'_i) \times 10^7$

Record Number 19

O—O $f(r)$ Measured

X—X $f(r) = \cos r$

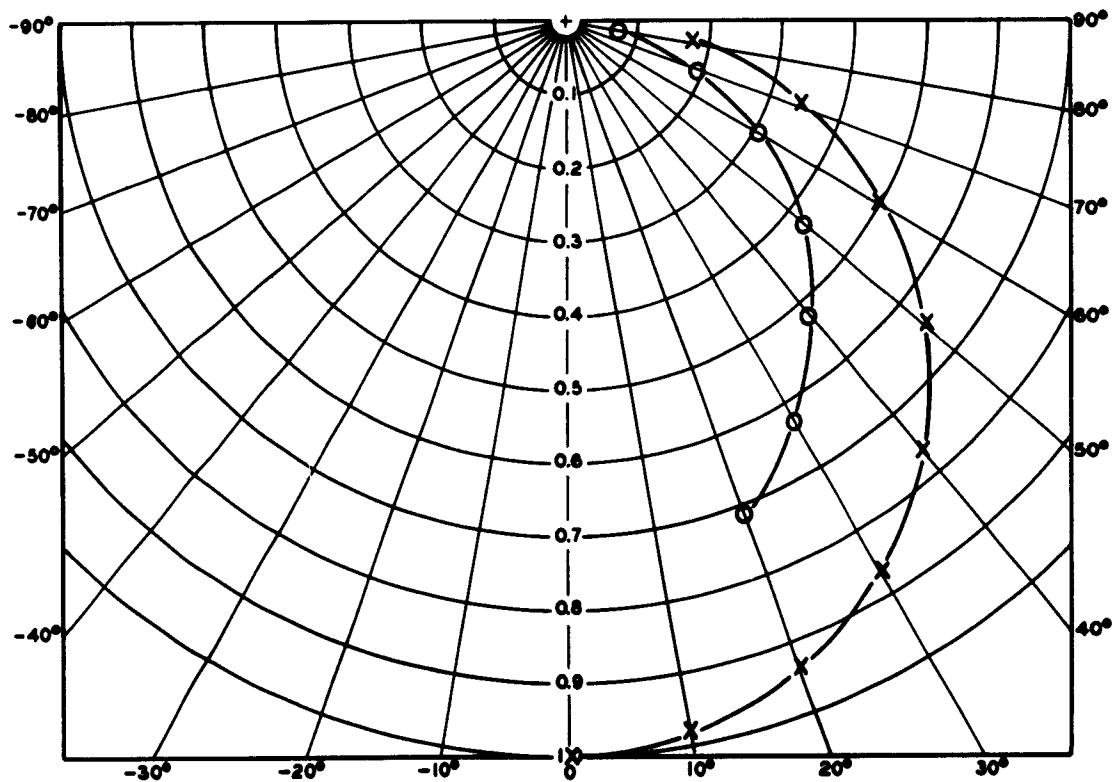

SPECTROMETER DATA

Contract AF 33(657)-9014

Record number	<u>20</u>	Incidence	<u>i=40°</u>
Type Reflection	<u>Diffuse</u>	Filter	<u>O.T. #656 red</u>
Remarks:		Sample	<u>Diffuse Standard</u>
		Dimensions	<u>Disc, 2r=2.5cm</u>
		Coating	<u>MgO #3, t=2mm</u>

Incident Light	<u>I_i=0.00352</u>	Reference:	<u>at i=0°, r=45°</u>
Adj. Ref. for I _i	<u>1.66 x 10⁻⁷</u>	For reflected light	<u>I_r=0.0500 x 10⁻⁷</u>
I' _i (adj. for ref.)	<u>0.00382</u>	Filter	<u>O.T. #656 red</u>
		b.c.	<u>2.37 x 10⁻⁹</u>
		Lamp	<u>4.98 volts</u>
		I' _r adj.	<u>0.0278 x 10⁻⁷</u>

r	I _r x10 ⁷ (amps)	Lamp Voltage(volts)	b.c.x10 ⁹ (amps)	I' _r x10 ⁷ (amps)	(I' _r /I' _i)x10 ⁷
0°	0.0520	4.98	2.38	0.0268	7.01
10°	0.0514	4.98	2.38	0.0263	6.88
20°	0.0499	4.98	2.38	0.0248	6.49
30°	0.0474	4.98	2.38	0.0225	5.89
40°	0.0450	4.98	2.38	0.0200	5.23
50°	0.0419	4.98	2.38	0.0171	4.48
60°	0.0375	4.98	2.38	0.0125	3.27
70°	0.0337	4.98	2.38	0.0086	2.25
80°	0.0291	4.98	2.38	0.0038	0.99
0°	0.0520	4.98	2.38		

SPECTROMETER DATA

Contract AF 33(657)-9014

Record number	<u>21</u>	Incidence	<u>$i=60^\circ$</u>
Type Reflection	<u>Diffuse</u>	Filter	<u>O.T. #656 red</u>
Remarks:		Sample	<u>Diffuse Standard</u>
		Dimensions	<u>Disc. $2r=2.5cm$</u>
		Coating	<u>MgO #3. $t=2mm$</u>
Incident Light	<u>$I_i=0.00230$</u>	Reference:	<u>at $i=0^\circ, r=45^\circ$</u>
Adj. Ref. for I_i	<u>1.66×10^{-7}</u>	For reflected light	<u>$I_r=0.0535 \times 10^{-7}$</u>
I'_i (adj. for ref.)	<u>0.00243</u>	Filter	<u>O.T. #656 red</u>
		b.c.	<u>2.70×10^{-9}</u>
		Lamp	<u>5.00 volts</u>
		I'_r adj.	<u>0.0271×10^{-7}</u>

r	$I_r \times 10^7$ (amps)	Lamp Voltage (volts)	b.c. $\times 10^9$ (amps)	$I'_r \times 10^7$ (amps)	$(I'_r/I'_i) \times 10^7$
-20°	0.0437	5.00	2.69		
-10°	0.0440	4.99	2.69		
0°	0.0440	4.98	2.70	0.0155	6.38
10°	0.0438	4.98	2.70	0.0155	6.38
20°	0.0430	4.98	2.70	0.0148	6.09
30°	0.0421	5.00	2.70	0.0132	5.43
40°	0.0410	5.00	2.70	0.0120	4.94
50°	0.0393	4.99	2.70	0.0108	4.44
60°	0.0373	4.99	2.70	0.0087	3.58
70°	0.0350	5.00	2.70	0.0055	2.26
80°	0.0319	4.99	2.70	0.0022	0.91
-20°	0.0439	4.98	2.70		

Function of the Angle of Reflection $f(r) = (I'_r/I'_i) \times 10^7$

Record Number 21

○—○ $f(r)$ Measured

x—x $f(r) = \cos r$

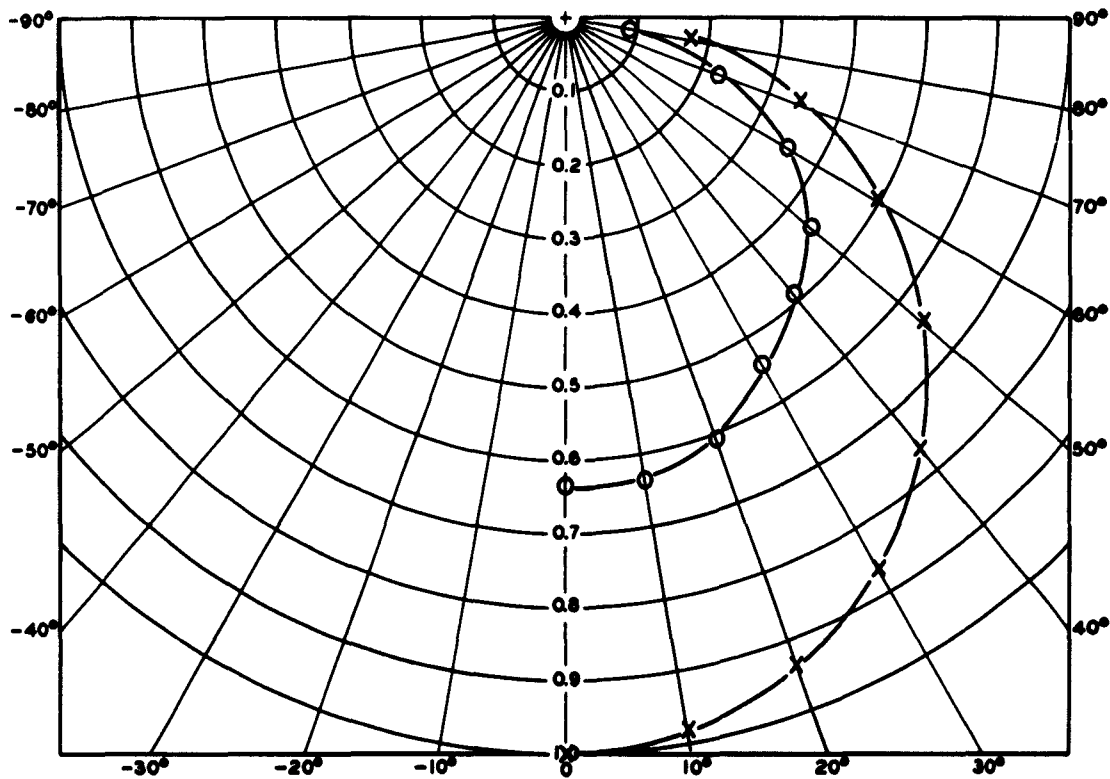

SPECTROMETER DATA

Contract AF 33(657)-9014

Record number	<u>22</u>	Incidence	<u>$i=80^\circ$</u>
Type Reflection	<u>Diffuse</u>	Filter	<u>O.T. #656 red</u>
Remarks:		Sample	<u>Diffuse Standard</u>
		Dimensions	<u>Disc, 2r=2.5cm</u>
		Coating	<u>MgO #3, t=2mm</u>
Incident Light	<u>$I_i=0.0008$</u>	Reference:	<u>at $i=0^\circ, r=45^\circ$</u>
Adj. Ref. for I_i	<u>1.66×10^{-7}</u>	For reflected light	<u>$I_r=0.0530 \times 10^{-7}$</u>
I'_i (adj. for ref.)	<u>0.000856</u>	Filter	<u>O.T. #656 red</u>
		b.c.	<u>2.67×10^{-9}</u>
		Lamp	<u>4.99 volts</u>
		I'_r adj.	<u>0.0274×10^{-7}</u>

r	$I_r \times 10^7$ (amps)	Lamp Voltage (volts)	b.c. $\times 10^9$ (amps)	$I'_r \times 10^7$ (amps)	$(I'_r / I'_i) \times 10^7$
-40°	0.0317	5.00	2.70	0.0048	5.60
0°	0.0322	4.99	2.70	0.0056	6.54
40°	0.0317	4.99	2.70	0.0051	5.96

Function of the Angle of Reflection $f(r) = (I'_r / I'_i) \times 10^7$

Record Number 22

O $f(r)$ Measured
X—X $f(r) = \cos r$

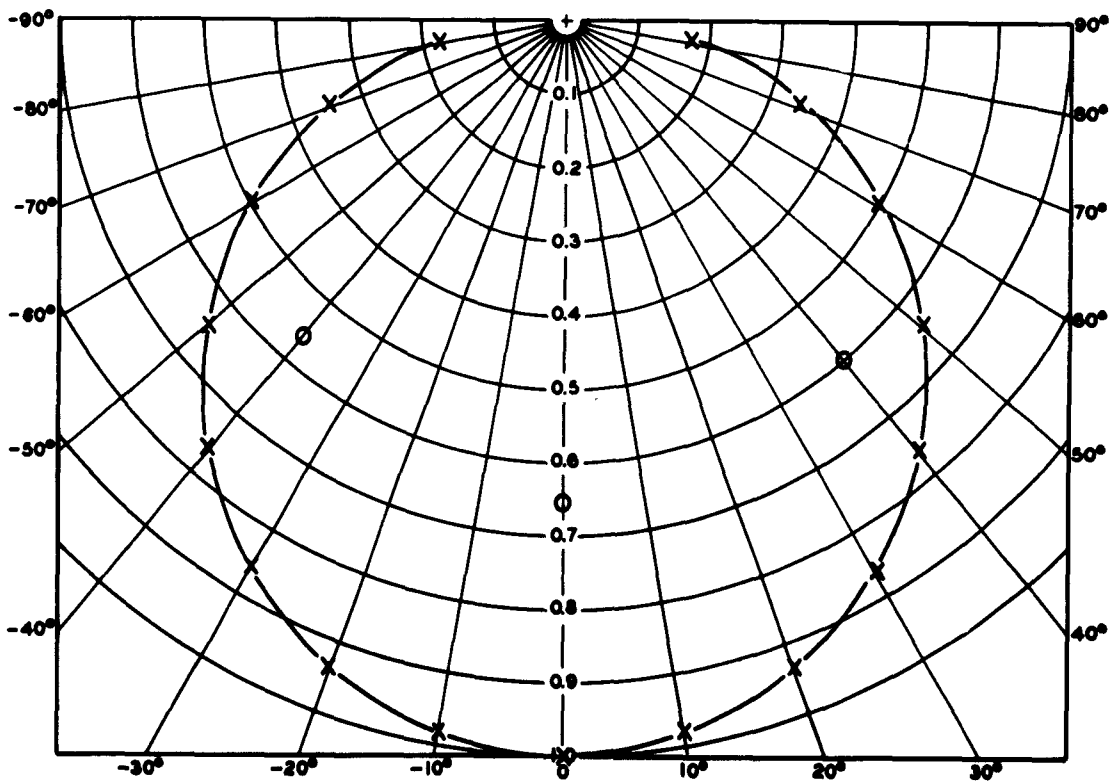

SPECTROMETER DATA

Contract AF 33(657)-9014

Record number	<u>23</u>	Incidence	<u>$i=0^\circ$</u>
Type Reflection	<u>Diffuse-Specular</u>	Filter	<u>None</u>
Remarks: <u>Paint coat one day old</u>		Sample	<u>W.P. on polished Al</u>
		Dimensions	<u>Disc. $2r=2.5\text{cm}$</u>
		Coating	<u>White Paint</u>
Incident Light	<u>0.298</u>	Reference:	<u>at $i=0^\circ, r=45^\circ$</u>
Adj. Ref. for I_i	<u>1.66×10^{-7}</u>	For reflected light	<u>1.44×10^{-7}</u>
I'_i (adj. for ref.)	<u>0.274</u>	Filter	<u>None</u>
		b.c.	<u>1.74×10^{-9}</u>
		Lamp	<u>5.00 volts</u>
		I'_r adj.	<u>1.38×10^{-7}</u>

r	$I_r \times 10^7$ (amps)	Lamp Voltage (volts)	b.c. $\times 10^9$ (amps)	$I'_r \times 10^7$ (amps)	$(I'_r / I'_i) \times 10^7$
35°	1.73	5.00	1.54	1.67	
40°	1.60	5.00	1.54	1.54	
50°	1.31	5.00	1.54	1.26	
60°	1.01	5.00	1.54	0.966	
70°	0.645	5.00	1.62	0.610	
80°	0.258	5.00	1.62	0.239	
85°	0.100	4.99	1.62	0.082	
35°	1.71	4.99			

SPECTROMETER DATA

Contract AF 33(657)-9014

Record number	<u>24</u>	Incidence	<u>i=45°</u>
Type Reflection	<u>Diffuse-Specular</u>	Filter	<u>None</u>
Remarks: <u>Refs. for I_i and I_r both compared to full beam ref.</u>		Sample	<u>W.P. on polished Al</u>
		Dimensions	<u>Disc, 2r=2.5cm</u>
		Coating	<u>White Paint</u>
Incident Light	<u>0.298 cos 45°</u>	Reference:	<u>at i=0°, r=45°</u>
Adj. Ref. for I _i	<u>1.66 x 10⁻⁷</u>	For reflected light	<u>1.42 x 10⁻⁷</u>
I' _i (adj. for ref.)	<u>0.191 except at i=r</u>	Filter	<u>None</u>
		b.c.	<u>2.11 x 10⁻⁹</u>
		Lamp	<u>5.00 volts</u>
		I' _r adj.	<u>1.36 x 10⁻⁷</u>

r	I _r x10 ⁷ (amps)	Lamp Voltage(volts)	b.c.x10 ⁹ (amps)	I' _r x10 ⁷ (amps)	(I' _r /I' _i)x10 ⁷
---	--	---------------------	-----------------------------	---	---

-10°	1.43	4.98	2.13		
0°	1.42	4.99	2.13	1.39	7.29
10°	1.39	4.99	2.13	1.35	7.08
20°	1.33	4.99	2.13	1.29	6.77
30°	1.25	4.98	2.14	1.21	6.35
40°	1.64	4.98	2.14	1.61	8.44
50°	1.79	4.98	2.13	1.76	9.23
60°	0.721	4.98	2.13	0.711	3.73
70°	0.450	4.98	2.13	0.435	2.28
80°	0.193	4.98	2.15	0.173	0.907
85°	0.083	4.98	2.15	0.060	0.315
-10°	1.39	4.98	2.15		
45° *	2.18	4.98	2.21	2.15	1130.

* N.D. #2

Function of the Angle of Reflection $f(r) = (I'_r / I'_i) \times 10^7$

Record Number 24

⊙—⊙ $f(r)$ Measured
 X—X $f(r) = \cos r$

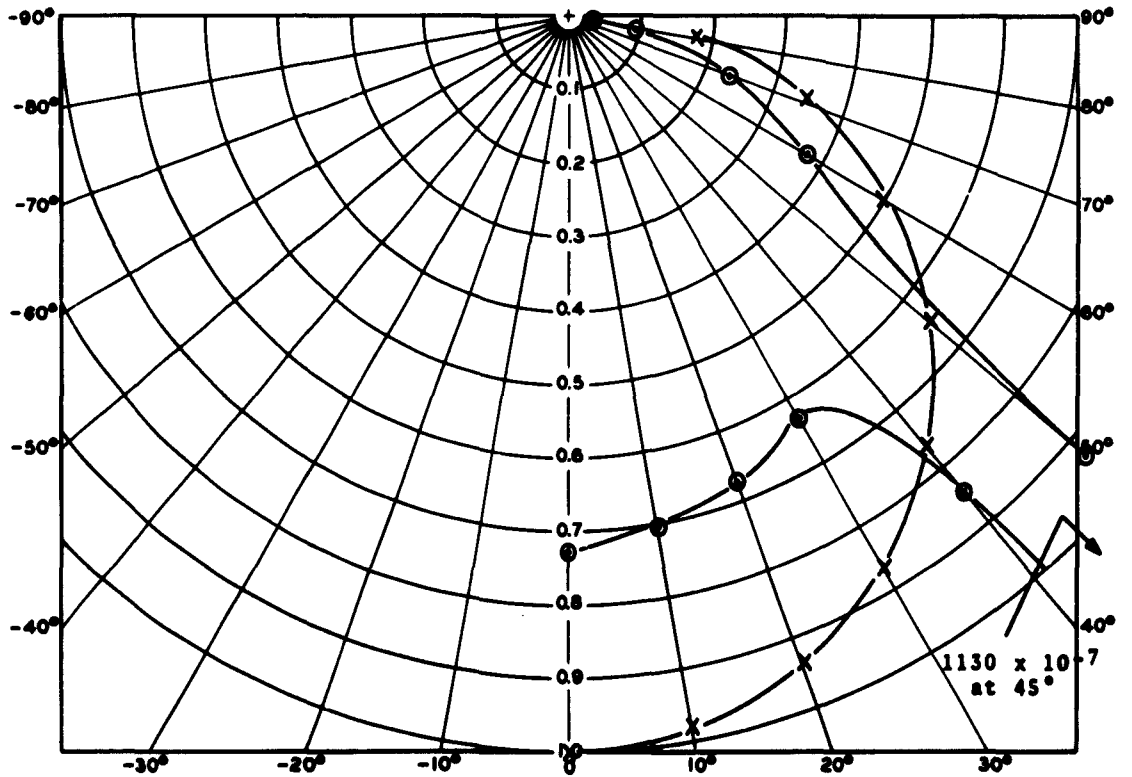

SPECTROMETER DATA

Contract AF 33(657)-9014

Record number	<u>25</u>	Incidence	<u>$i=85^\circ$</u>
Type Reflection	<u>Diffuse-Specular</u>	Filter	<u>None</u>
Remarks: <u>Sample very flat. I_r at 70° is 0.115 or 1.15</u>		Sample	<u>W.P. on polished Al</u>
		Dimensions	<u>Disc. $2r=2.5\text{cm}$</u>
		Coating	<u>White Paint</u>
Incident Light	<u>$0.298 \cos 85^\circ$</u>	Reference:	<u>at $i=0^\circ, r=45^\circ$</u>
Adj. Ref. for I_i	<u>1.66×10^{-7}</u>	For reflected light	<u>1.38×10^{-7}</u>
I'_i (adj. for ref.)	<u>0.0228 except at $i=r$</u>	Filter	<u>None</u>
		b.c.	<u>2.16×10^{-9}</u>
		Lamp	<u>5.00 volts</u>
		I'_r adj.	<u>1.32×10^{-7}</u>

r	$I_r \times 10^7$ (amps)	Lamp Voltage (volts)	b.c. $\times 10^9$ (amps)	$I'_r \times 10^7$ (amps)	$(I'_r / I'_i) \times 10^7$
0°	0.0880	4.99	2.15	0.0664	2.91
10°	0.0872	4.99	2.15	0.0657	2.88
20°	0.0850	4.99	2.15	0.0635	2.79
30°	0.0815	4.99	2.15	0.0602	2.64
40°	0.0770	4.98	2.15	0.0553	2.43
50°	0.0735	4.98	2.15	0.0513	2.25
60°	0.0770	4.98	2.15	0.0543	2.38
70°	0.115	4.98	2.15	0.091	3.99
80°	1.70	4.98	2.15	1.66	72.8
0°	0.0880	4.98	2.17	0.0664	2.91
85° *	12.5	4.98	2.21	12.4	54,400.

* N.D. #2

Function of the Angle of Reflection $f(r) = (I'_r/I'_i) \times 10^7$

Record Number 25

⊙—⊙ $f(r)$ Measured
 X—X $f(r) = \cos r$

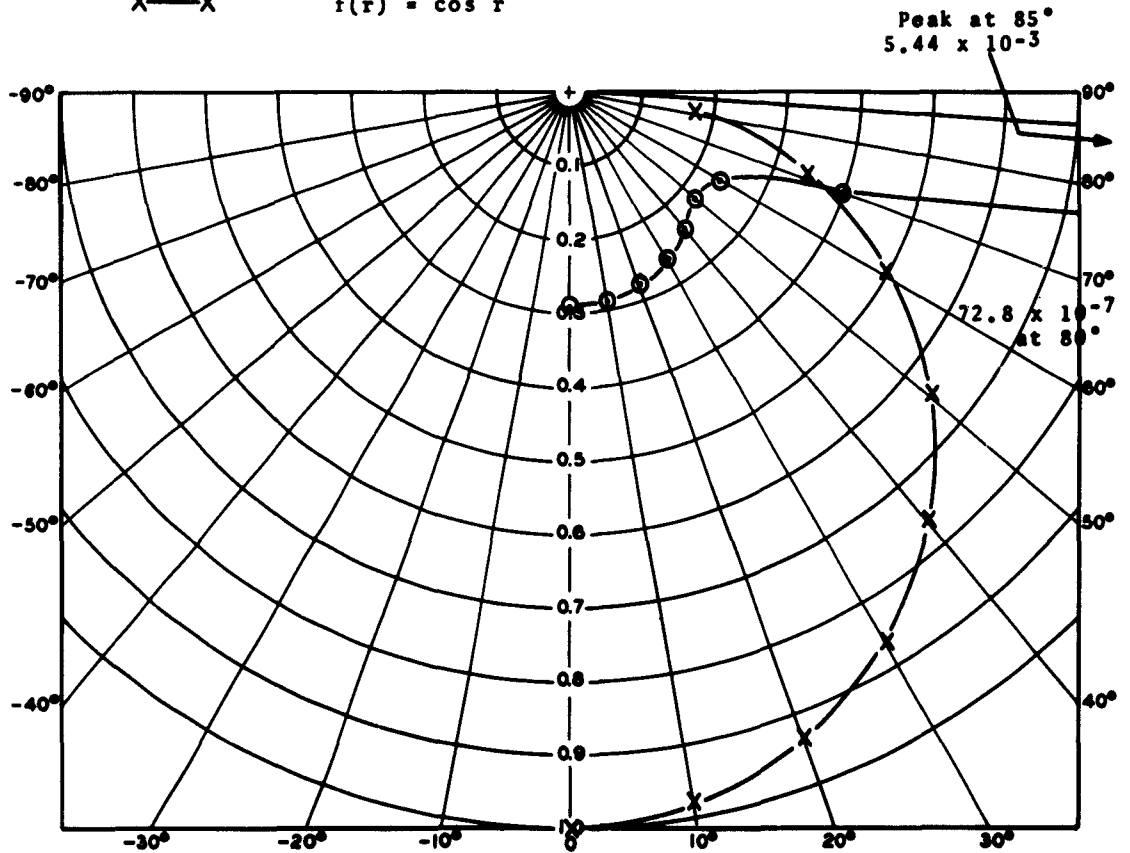

SPECTROMETER DATA

Contract AF 33(657)-9014

Record number	<u>29</u>	Incidence	<u>i=0°</u>
Type Reflection	<u>Diffuse</u>	Filter	<u>Wr #47 blue</u>
Remarks: <u>Not normalized, only d.c. subtracted.</u>		Sample	<u>Front surface mirror</u>
		Dimensions	<u>2.8 x 1.7=4.76cm²</u>
		Coating	<u>MgO #1, t=0.5mm</u>
Incident Light	<u>No. ref.</u>	Reference:	<u>None</u>
Adj. Ref. for I _i	<u> </u>	For reflected light	<u> </u>
I _i (adj. for ref.)	<u> </u>	Filter	<u> </u>
		b.c.	<u> </u>
		Lamp	<u> </u>
		I _r adj.	<u> </u>

r	I _r x10 ⁷ (amps)	Lamp Voltage(volts)	b.c. x10 ⁹ (amps)	I _r 'x10 ⁷ (amps)	(I _r '/I _i ')x10 ⁷
---	--	---------------------	------------------------------	---	---

35°	0.87	5.0	2.00	0.85	
40°	0.80	5.0	2.00	0.78	
45°	0.73	5.0	2.00	0.71	
50°	0.65	5.0	2.00	0.63	
60°	0.48	5.0	2.00	0.46	
70°	0.31	5.0	2.00	0.29	
80°	0.15	5.0	2.00	0.13	
85°	0.085	5.0	2.00	0.065	
-40°	0.85	5.0	1.87	0.83	
-50°	0.71	5.0	1.85	0.69	
-60°	0.54	5.0	1.85	0.52	
-70°	0.35	5.0	1.83	0.33	
-80°	0.17	5.0	1.83	0.15	
-85°	0.087	5.0	1.83	0.069	

Function of the Angle of Reflection $f(r) = (I'_r/I'_i) \times 10^7$

Record Number 29

⊙—⊙ $f(r)$ Measured

X—X $f(r) = \cos r$

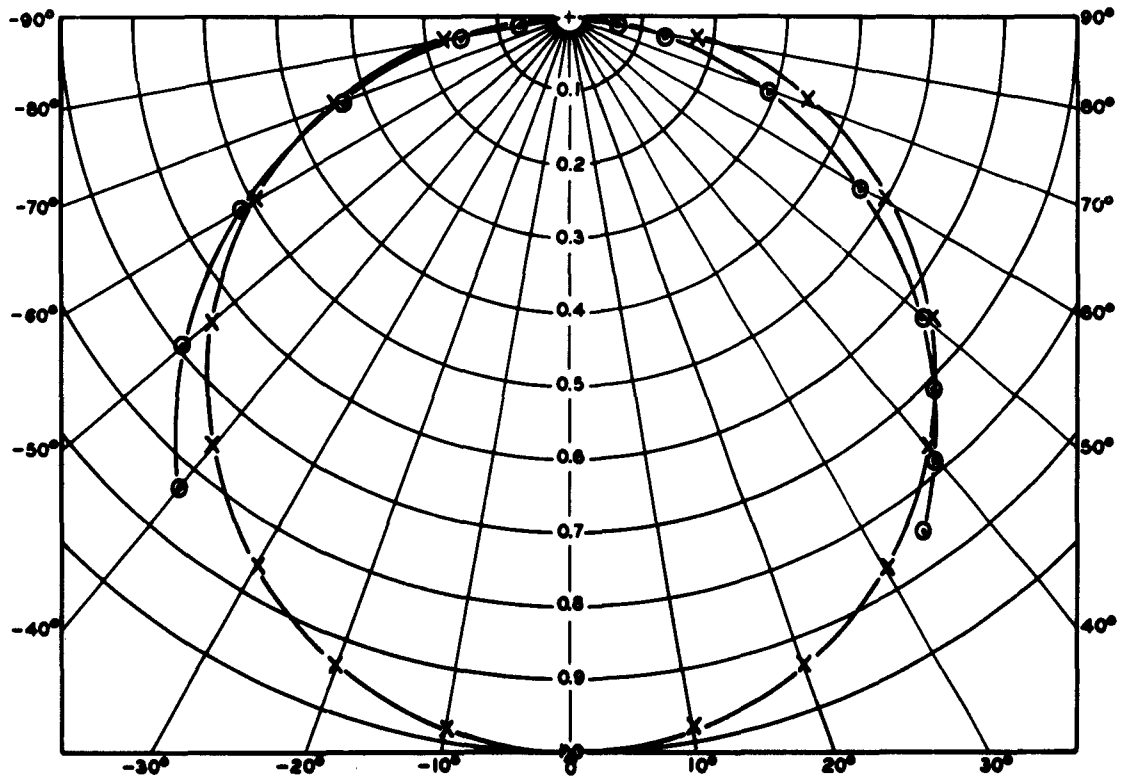

SPECTROMETER DATA

Contract AF 33(657)-9014

Record number 30 Incidence $i=20^\circ$
 Type Reflection Diffuse Filter Wr #47
 Remarks: Not normalized only d.c. Sample Front surface mirror
subtracted Dimensions $2.8 \times 1.7=4.76\text{cm}^2$
 Coating MgO #1, t=0.5mm

Incident Light No ref. Reference: None
 Adj. Ref. for I_i _____ For reflected light _____
 I'_i (adj. for ref.) _____ Filter _____
 b.c. _____
 Lamp _____
 I'_R adj. _____

r	$I_R \times 10^7$ (amps)	Lamp Voltage (volts)	b.c. $\times 10^9$ (amps)	$I'_R \times 10^7$ (amps)	$(I'_R / I'_i) \times 10^7$
-----	--------------------------	----------------------	---------------------------	---------------------------	-----------------------------

15°	1.02	5.0	1.77	1.00	
20°	1.08	5.0	1.77	1.06	
25°	0.93	5.0	1.77	0.91	
30°	0.88	5.0	1.75	0.86	
40°	0.76	5.0	1.75	0.74	
50°	0.63	5.0	1.75	0.61	
60°	0.48	5.0	1.75	0.46	
70°	0.32	5.0	1.75	0.30	
80°	0.16	5.0	1.75	0.14	
85°	0.085	5.0	1.75	0.067	

Function of the Angle of Reflection $f(r) = (I'_r/I'_i) \times 10^7$

Record Number 30

⊙—⊙ $f(r)$ Measured

X—X $f(r) = \cos r$

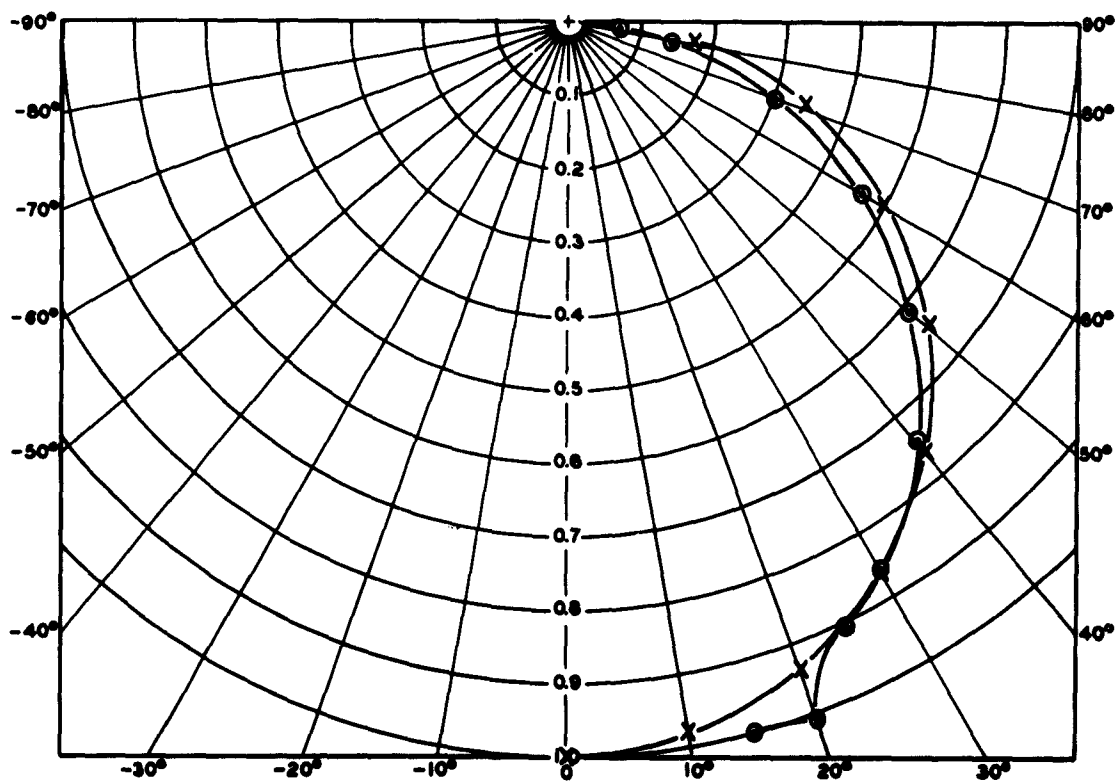

SPECTROMETER DATA

Contract AF 33(657)-9014

Record number	<u>31</u>	Incidence	<u>i=45°</u>
Type Reflection	<u>Diffuse</u>	Filter	<u>Wr #47 blue</u>
Remarks:	<u>Not normalized, only d.c. subtracted</u>	Sample	<u>Front surface mirror</u>
		Dimensions	<u>2.8 x 1.7=4.76cm²</u>
		Coating	<u>MgO #1, t=0.5μ</u>
Incident Light	<u>No ref.</u>	Reference:	<u>None</u>
Adj. Ref. for I _i		For reflected light	
I' _i (adj. for ref.)		Filter	
		b.c.	
		Lamp	
		I' _r adj.	

r	I _r x 10 ⁷ (amps)	Lamp Voltage (volts)	b.c. x 10 ⁹ (amps)	I' _r x 10 ⁷ (amps)	(I' _r /I' _i) x 10 ⁷
---	---	----------------------	-------------------------------	--	---

-10°	0.755	5.0	1.90	0.736	
-5°	0.765	5.0	1.95	0.745	
0°	0.765	5.0	1.95	0.745	
5°	0.755	5.0	2.00	0.735	
10°	0.750	5.0	2.00	0.730	
20°	0.710	5.0	2.00	0.690	
30°	0.660	5.0	2.08	0.639	
40°	0.585	5.0	2.08	0.564	
45°	0.572	5.0	2.08	0.551	
50°	0.502	5.0	2.14	0.481	
60°	0.405	5.0	2.14	0.384	
70°	0.292	5.0	2.15	0.271	
80°	0.168	5.0	2.15	0.147	
85°	0.098	5.0	2.15	0.077	

Function of the Angle of Reflection $f(r) = (I'_r/I'_i) \times 10^7$

Record Number 31

⊙—⊙ $f(r)$ Measured
 X—X $f(r) = \cos r$

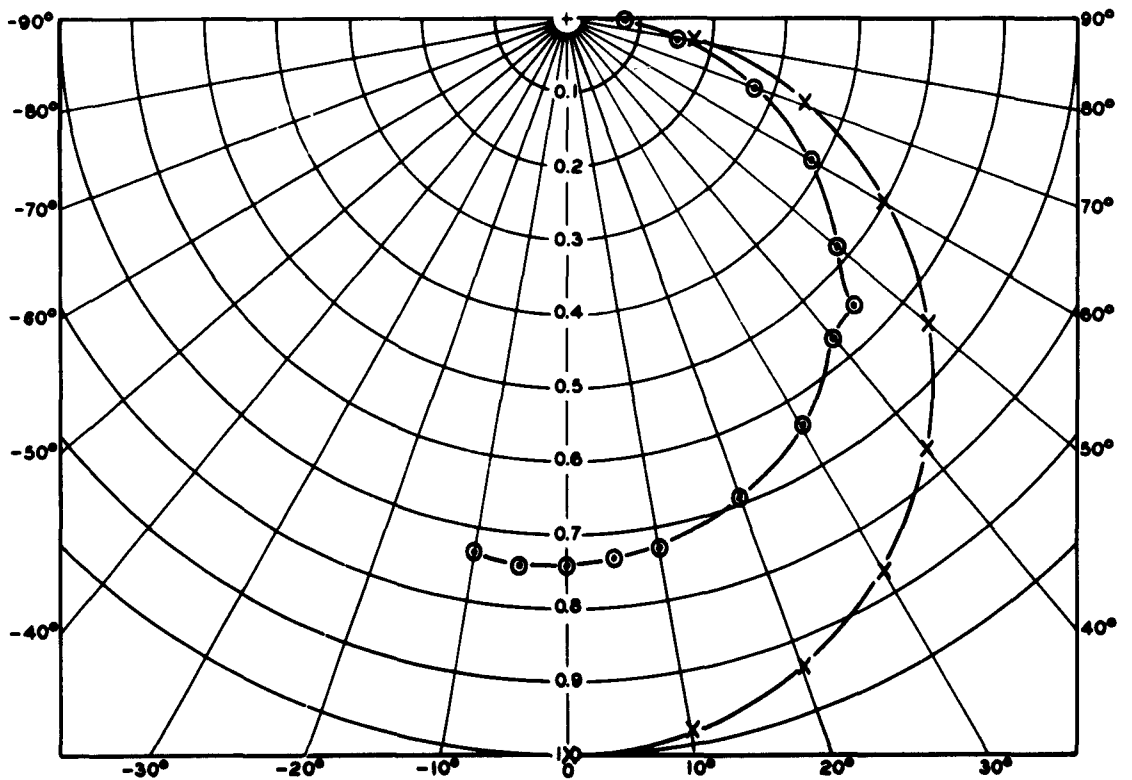

SPECTROMETER DATA

Contract AF 33(657)-9014

Record number	<u>32</u>	Incidence	<u>i=60°</u>
Type Reflection	<u>Diffuse</u>	Filter	<u>Wr #47 blue</u>
Remarks:	<u>Not normalized, only d.c. subtracted</u>	Sample	<u>Front surface mirror</u>
		Dimensions	<u>2.8 x 1.7=4.76cm²</u>
		Coating	<u>MgO #1, t=0.5mm</u>
Incident Light	<u>No ref.</u>	Reference:	<u>None</u>
Adj. Ref. for I _i		For reflected light	
I' _i (adj. for ref.)		Filter	
		b.c.	
		Lamp	
		I' _r adj.	

r	$I_r \times 10^7$ (amps)	Lamp Voltage (volts)	b.c. $\times 10^9$ (amps)	$I'_r \times 10^7$ (amps)	$(I'_r / I'_i) \times 10^7$
0°	.535	5.0	2.00	0.515	
+5°	.530	5.0	2.05	0.509	
10°	.528	5.0	2.10	0.507	
20°	.510	5.0	2.10	0.489	
30°	.485	5.0	2.10	0.464	
40°	.448	5.0	2.10	0.427	
50°	.407	5.0	2.06	0.386	
55°	.381	5.0	2.06	0.360	
60°	.358	5.0	2.06	0.337	
65°	.321	5.0	2.06	0.300	
70°	.283	5.0	2.03	0.263	
80°	.183	5.0	2.03	0.163	
85°	.112	5.0	2.03	0.092	

Function of the Angle of Reflection $f(r) = (I_r'/I_i') \times 10^7$

Record Number 32

⊙—⊙ $f(r)$ Measured

X—X $f(r) = \cos r$

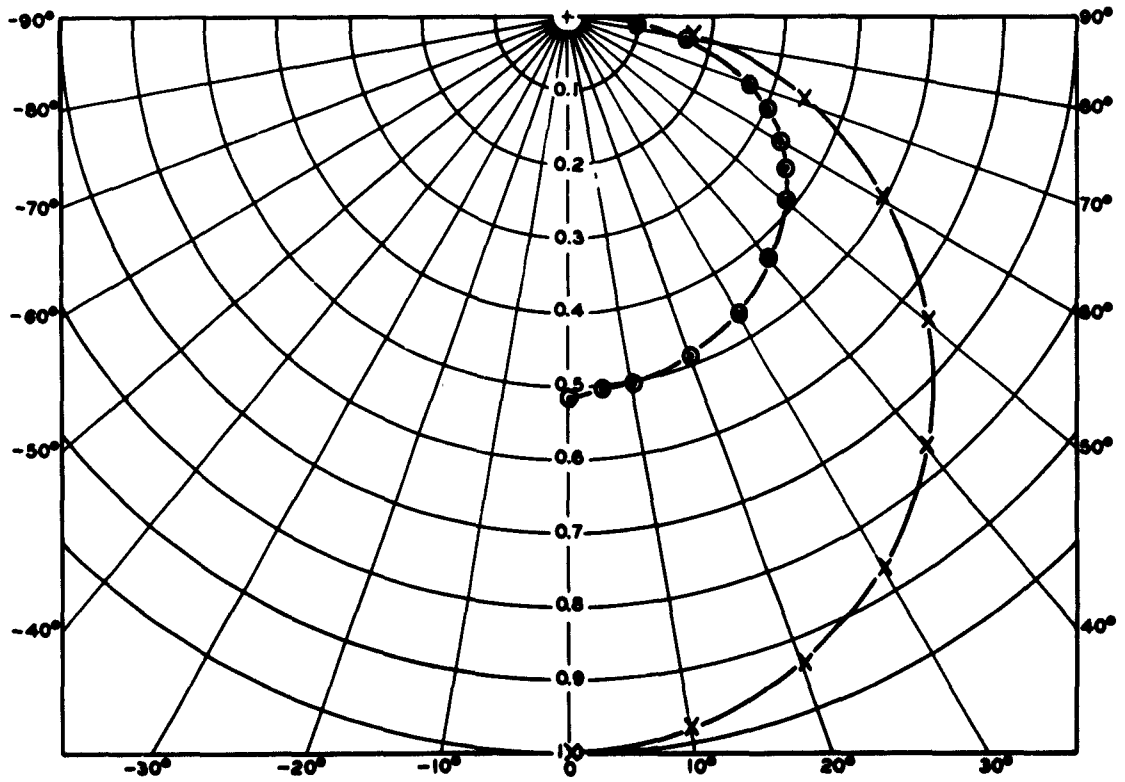

SPECTROMETER DATA

Contract AF 33(657)-9014

Record number	<u>33</u>	Incidence	<u>i=20°</u>
Type Reflection	<u>Diffuse</u>	Filter	<u>Wr #47 blue</u>
Remarks:	<u>Not normalized, only d.c. subtracted</u>	Sample	<u>Front surface mirror</u>
		Dimensions	<u>2.8 x 1.7=4.76cm²</u>
		Coating	<u>MgO #2. t=1μm</u>
Incident Light	<u>No ref.</u>	Reference:	<u>None</u>
Adj. Ref. for I _i	<u> </u>	For reflected light	<u> </u>
I' _i (adj. for ref.)	<u> </u>	Filter	<u> </u>
		b.c.	<u> </u>
		Lamp	<u> </u>
		I' _r adj.	<u> </u>

r	I _r x10 ⁷ (amps)	Lamp Voltage(volts)	b.c.x10 ⁹ (amps)	I' _r x10 ⁷ (amps)	(I' _r /I' _i)x10 ⁷
15°	0.970	5.0	2.53	0.945	
20°	0.940	5.0	2.53	0.915	
25°	0.900	5.0	2.53	0.875	
30°	0.840	5.0	2.53	0.815	
40°	0.735	5.0	2.53	0.710	
50°	0.600	5.0	2.53	0.575	
60°	0.458	5.0	2.53	0.433	
70°	0.308	5.0	2.53	0.283	
80°	0.161	5.0	2.53	0.136	
85°	0.091	5.0	2.53	0.066	

Function of the Angle of Reflection $f(r) = (I'_r / I'_i) \times 10^7$

Record Number 33

⊙—⊙ $f(r)$ Measured
X—X $f(r) = \cos r$

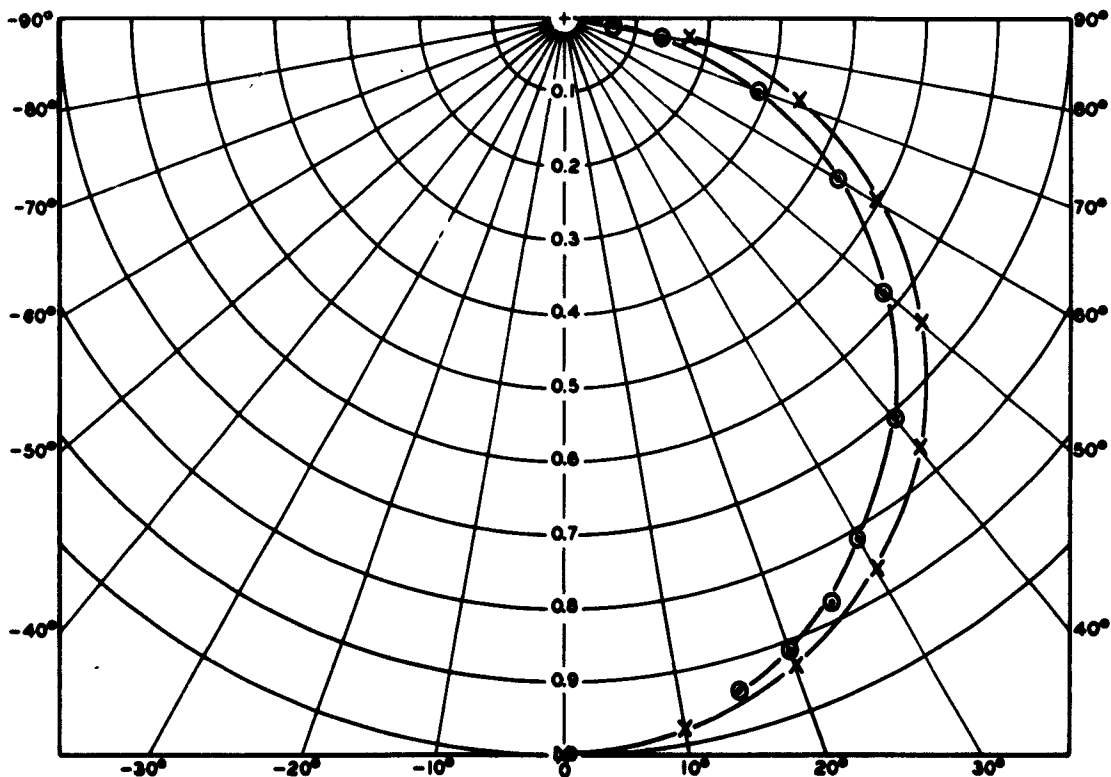

SPECTROMETER DATA

Contract AF 33(657)-9014

Record number	<u>26</u>	Incidence	<u>$i=r$</u>
Type Reflection	<u>Diffuse-Specular</u>	Filter	<u>ND #2</u>
Remarks:	<u>Full beam ref. for I_i meas.</u>	Sample	<u>W.P. on polished Al</u>
	<u>$=3.96 \times 10^{-7}$</u>	Dimensions	<u>Disc. $2r=2.5$cm</u>
		Coating	<u>White Paint</u>
Incident Light	<u>0.298 (cos i)</u>	Reference:	<u>at $i=0^\circ$, $r=45^\circ$</u>
Adj. Ref. for I_i	<u>1.66×10^{-7}</u>	For reflected light	<u>1.37×10^{-7}</u>
I'_i (adj. for ref.)	<u>0.00268 (cos i)</u>	Filter	<u>None</u>
		b.c.	<u>2.18×10^{-9}</u>
		Lamp	<u>4.98 volts</u>
		I'_r adj.	<u>1.35×10^{-7}</u>

r	$I_r \times 10^7$ (amps)	Lamp Voltage (volts)	b.c. $\times 10^9$ (amps)	$I'_r \times 10^7$ (amps)	$(I'_r / I'_i) \times 10^7$
60°	3.97	4.98	2.20	3.93	2930.
17.5°	1.50	4.98	2.20	1.46	570.

Reference: full beam with filters ND #2, #3, #1

180°	3.60	4.98	2.19	3.56	
------	------	------	------	------	--

SPECTROMETER DATA

Contract AF 33(657)-9014

Record number	<u>27</u>	Incidence	<u>i=r</u>
Type Reflection	<u>Specular</u>	Filter	<u>ND #2</u>
Remarks: I_r Ref. high. I_r/I_i probably slightly higher than shown		Sample	<u>W.P. on polished Al</u>
		Dimensions	<u>Disc. 2r=2.5cm</u>
		Coating	<u>White Paint</u>
Incident Light	<u>0.298 cos i</u>	Reference:	<u>Full beam at 180°</u>
Adj. Ref. for I_i	<u>1.66 x 10⁻⁷</u>	For reflected light	<u>5.25 x 10⁻⁷</u>
I'_i (adj. for ref.)	<u>0.00384 (cos i)</u>	Filter	<u>ND #2, #3, #1</u>
		b.c.	<u>2.35 x 10⁻⁷</u>
		Lamp	<u>5.00 volts</u>
		I'_r adj.	<u>5.10 x 10⁻⁷</u>

r	$I_r \times 10^7$ (amps)	Lamp Voltage (volts)	b.c. $\times 10^9$ (amps)	$I'_r \times 10^7$ (amps)	$(I'_r/I'_i) \times 10^7$
17.5°	1.30	4.99	2.35	1.25	342.
45°	1.54	4.99	2.35	1.48	546.
85°	8.00	4.99	2.35	7.85	23,500.

SPECTROMETER DATA

Contract AF 33(657)-9014

Record number	<u>28</u>	Incidence	<u>i=r</u>
Type Reflection	<u>Specular</u>	Filter	<u>ND #3, ND #1</u>
Remarks:	<u>High polish but not optically flat</u>	Sample	<u>Polished Al</u>
		Dimensions	<u>Disc. 2r=2.5cm</u>
		Coating	<u>None</u>
Incident Light	<u>0.298 (cos i)</u>	Reference:	<u>Full beam at 180°</u>
Adj. Ref. for I _i	<u>1.66 x 10⁻⁷</u>	For reflected light	<u>4.03 x 10⁻⁷</u>
I _i (adj. for ref.)	<u>3 x 10⁻⁵ (cos i)</u>	Filter	<u>ND #2, #3, #1</u>
		b.c.	<u>2.37 x 10⁻⁹</u>
		Lamp	<u>4.98 volts</u>
		I _r adj.	<u>3.99 x 10⁻⁷</u>

r	I _r x 10 ⁷ (amps)	Lamp Voltage (volts)	b.c. x 10 ⁹ (amps)	I _r ' x 10 ⁷ (amps)	(I _r ' / I _i) x 10 ⁷
17.5°	0.189	4.99	2.33	0.165	5770.
45°	0.135	4.98	2.34	0.111	5240.
60°	0.108	4.98	2.35	0.084	5600.
85°	0.0514	4.98	2.35	0.0244	9350.

* Error in B.G. off shaft