

UNCLASSIFIED

AD 408 929

DEFENSE DOCUMENTATION CENTER

FOR

SCIENTIFIC AND TECHNICAL INFORMATION

CAMERON STATION, ALEXANDRIA, VIRGINIA



UNCLASSIFIED

NOTICE: When government or other drawings, specifications or other data are used for any purpose other than in connection with a definitely related government procurement operation, the U. S. Government thereby incurs no responsibility, nor any obligation whatsoever; and the fact that the Government may have formulated, furnished, or in any way supplied the said drawings, specifications, or other data is not to be regarded by implication or otherwise as in any manner licensing the holder or any other person or corporation, or conveying any rights or permission to manufacture, use or sell any patented invention that may in any way be related thereto.

NOTICES

When Government drawings, specifications, or other data are used for any purpose other than in connection with a definitely related Government procurement operation, the United States Government thereby incurs no responsibility nor any obligation whatsoever; and the fact that the Government may have formulated, furnished, or in any way supplied the said drawings, specifications, or other data, is not to be regarded by implication or otherwise as in any manner licensing the holder or any other person or corporation, or conveying any rights or permission to manufacture, use, or sell any patented invention that may in any way be related thereto.

Qualified requesters may obtain copies of this report from the Armed Services Technical Information Agency, (ASTIA), Arlington Hall Station, Arlington 12, Virginia.

This report has been released to the Office of Technical Services, U.S. Department of Commerce, Washington 25, D.C., in stock quantities for sale to the general public.

Copies of this report should not be returned to the Aeronautical Systems Division unless return is required by security considerations, contractual obligations, or notice on a specific document.

FOREWORD

This report was prepared by Professor E. W. Müller and Mr. O. Nishikawa of the Department of Physics at The Pennsylvania State University, University Park, Pennsylvania, under Contract No. AF33(616)-6397. This contract was initiated under Project 7353, "Characterization of Solid Phase and Interphase Phenomena in Crystalline Substances", Task 735304, "Structure, Behavior, and Growth of Unique Crystalline Substances", with Mr. J. S. Taylor, ASRCMS, Directorate of Materials and Processes, acting as project engineer.

ABSTRACT

The field ion microscope images of iron whiskers from various origins were observed and differentiations between iron whiskers and specimens made of pure iron wire were studied. Indications of crystal defects such as screw dislocations and axial disordered core structures were found. The influence of various gases on the iron surface under the extremely high electric field and the diffusion of potassium ions into the iron lattice was observed. The operation of the field ion microscope with neon gas gives certain advantages for the study of easily field evaporating metals such as iron.

This technical documentary report has been reviewed and is approved.



W. G. RANKE
Actg. Chief, Advanced Metallurgical
Studies Branch
Metals and Ceramics Laboratory
Directorate of Materials and Processes

TABLE OF CONTENTS

	Page
I. INTRODUCTION	1
II. VACUUM CONDITIONS	1
III. PREPARATION OF WHISKER TIP SPECIMENS	2
IV. OBSERVATION OF WHISKER SPECIMENS	6
V. EMITTER SPECIMENS OF PURE IRON WIRES	12
VI. INFLUENCE OF ADSORPTION ON IRON SPECIMENS	14
VII. QUALITY OF THE NEON IMAGE	18
<hr/>	
VIII. CONCLUSION	22
IX. LIST OF REFERENCES	24

LIST OF ILLUSTRATIONS

Figure	Page
1 Field Ion Microscope Tube with a Titanium Getter Tube and a Gas Source	3
2 Crimping Tool for Fastening the Fine Whisker Specimen in a Platinum Capillary	5
3a,b,c,d Field Evaporation Process of (001) Plane with Double Screw Dislocation. The Plane in the Center Below is (011) Plane. General Electric Whisker. Helium Ion Image at 16.2kv, Tip at 21°K. Whisker Diameter 42 Microns. Photo No. ON 1293-96 ..	7
4a General Electric Whisker with Single Screw Dislocation on (123) Plane. Helium Ion Image at 10.6kv, 21°K. Whisker Diameter 16 Microns. Photo No. ON 1523	8
4b General Motors Whisker, Original Diameter 300 Microns Neon Image at 13.0kv, 21°K, $[111]$ Orientation Center. The Three Planes with the Large Net Plane Ring Systems Two-Thirds Toward the Edge are the (011) Planes. There are a Number of Dislocations. Photo No. ON 1339	8
4c General Motors Whisker. Helium Ion Image at 19.8kv, 21°K, $[001]$ Orientation Center. Photo No. ON 1802	8
5a WADD Whisker, Sample H-9, M-2. Whisker Diameter 80 Microns. Helium Ion Image at 12.6kv, 21°K. Photo No. ON 1359	10
5b Original Tip Shape of WADD H-86 Iron Whisker, Diameter 20 Microns at Tip and 170 Microns at Base	10
5c This Whisker is in $[111]$ Orientation, Helium 1.5 Microns at 21.2kv, 21°K. Photo No. ON 1896	10
5d WADD H-90 Whisker in $[111]$ Orientation, 100 Microns Diameter, Helium 1.2 Microns at 13.5kv, 21°K. Photo No. ON 1973	10
6a Puron Wire Tip in $[011]$ Orientation Which Had Not Been Annealed at All. Helium 1.6 Microns at 15.3kv 21°K. Photo No. ON 1316	13

Figure	Page
6b Puron Wire Tip in $[011]$ Orientation Which Was Annealed in Hydrogen Above Transition Point. Helium 1.5 Microns at 18.3kv, 21°K. Photo No. ON 1471	13
6c Field Electron Image of Iron Wire. Photo No. 39-48 ...	13
6d Ultra High Vacuum Annealed Puron Wire Tip in $[111]$ Orientation. Helium 1.5 Microns at 24.5kv, 21°K. Photo No. ON 1831	13
7a Ultra High Vacuum Annealed Puron Wire Tip was First Covered with a Small Amount of Potassium. All Potassium Ions were then Field Desorbed at 21°K. Helium Ion Image at 17.9kv, Tip Temperature 21°K, 1.1 Microns Helium. Photo No. ON 1839	16
7b Potassium was First Allowed to Diffuse into the Iron by Heating to Approximately 400°C. Subsequent Field Evaporation Exposes the Ions at the New Surface. Helium Ion Image at 21kv, Tip Temperature 21°K, 1.2 Microns Helium. Photo No. ON 1845	16
7c WADD T-1 Whisker Surface with a Number of Protruding Atom Rows on its Surface due to Hydrogen Effect. Helium 1 Micron at 13.5kv, Tip Temperature 21°K. Photo No. 1762	17
7d WADD T-1 Whisker Surface with a Number of Protruding Atom Rows on its Surface due to Hydrogen Effect. Helium 1 Micron at 13.5kv, Tip Temperature 21°K. Photo No. 1763	17
8a,b Neon 0.9 Microns and Helium 1.1 Microns Image of Tungsten Tip at 77°K Respectively. 9.8kv for Neon, 12.5kv for Helium, Photo No. ON 2085, 2087	19
8c,d Neon 1.2 Microns and Helium 1.2 Microns Image of Tungsten at 21°K Respectively. 10.7kv for Neon, 13.6kv for Helium. Photo No. ON 2135, 2134	19
9a WADD H-86 Whisker, Helium 1.5 Microns at 17.5kv, 21°K. Photo No. 1958	20
9b Neon 1 Micron Image of the Same Tip at 16.5kv, 21°K. Photo No. 1952	21

I. INTRODUCTION

This Technical Report covers the work carried out as a continuation of the efforts described in WADD Technical Report 60-534.

Field ion microscope techniques for the study of the atomic surface arrangement of iron whiskers were improved. A number of specimens from various origins were studied and their pictures were compared with those of pure iron specimens with the aim of obtaining information on the internal lattice structure, and the observations were then used to interpret the growth mechanism of these whiskers.

Investigation of the influence of various adsorbed gases and potassium on the image of iron specimens were studied. Since the previous Technical Report additional experience using neon as an ionizing gas has been obtained. In spite of its slightly lower resolution and very low image intensity compared with helium, neon can depict the easily evaporating regions such as the (111) plane and [011] zone line which could not be observed with the use of helium.

II. VACUUM CONDITIONS

There is enough experimental evidence that the stability of the iron specimen surface under the high field conditions depends upon the exclusion of minute gaseous contaminations. Disturbing impurities are probably water vapor, nitrogen, carbon monoxide and hydrogen.

If the iron whisker is affected by a residual contaminant, it might be possible to remove this by an iron getter. For this purpose a getter tube with some 200 cm² free area was added to the FIM, and a film of pure iron (99.95% Puron wire) was evaporated on the wall. In 1 micron of helium or 1.5 microns of neon the image obtained from a whisker was not fully stable, although it was better than before flashing the iron getter. Thereafter, the titanium getter is evaporated on the glass wall of a special liquid nitrogen cooled trap. Image stability is now so good that even low intensity neon images can be photographed with exposure times of several minutes without apparent

Manuscript released by the authors June 1962 for publication as an ASD Technical Documentary Report.

change in the pattern. This experiment then indicates clearly that the unknown contaminant does not react with pure iron under ordinary conditions either at room temperature or at liquid nitrogen temperature, while the reaction under the high field condition at the emitter is definitely taking place. It must then be a field induced chemical reaction.

Presently the experimental work has been improved with the incorporation of a larger titanium getter tube connected with the new FIM tube by a short, 45mm diameter glass tube. The gas source, which can see the tip directly and release oxygen, hydrogen and potassium was also installed (Figure 1).

III. PREPARATION OF WHISKER TIP SPECIMENS

The tips are prepared by an electrolytical etching process as described before¹. However, the attack of diluted HCl with an addition of HNO₃ often results in an uneven erosion of the specimen. Particularly whiskers in [011] axial orientation, having two fold symmetry only, develop chisel shaped tips rather than the desired ones with essentially round cross section. It was found that better results can be obtained by finishing the specimens in a concentrated high viscosity solution of phosphoric acid with approximately 5 to 8 volts dc applied between the whisker and a platinum wire cathode. The rate of attack is very slow, but it gives smooth tips of fine radius. After etching in concentrated HCl 25% + HNO₃ 25% + H₂O 50% with 2.5 to 6 volts dc some of the whiskers showed very clean and smooth surfaces and a perfect tip shape.

Mounting of the whiskers was originally done by spot-welding them to a tungsten heater loop. In the present equipment the spot-welder is energized by a condenser discharge through the primary of the transformer. However, the mechanical precision is only good enough for handling whiskers down to 20 microns diameter. Finer specimens are of greater interest to this investigation as only the whiskers with small diameters can be expected to exhibit the desirable high strength. Emphasis was placed on the development of handling techniques for extremely fine specimens, such as the attempt to use a soldering technique. The heater loop was first mounted inside a glass tube through which highly purified hydrogen was streaming. A small sphere of tin, silver or gold was then fastened at the lower center of the loop by touching the heated loop with a piece of wire of one of these metals. Then an iron whisker was pushed into the molten metal sphere (of about 5 to 20 mils diameter) with the help of a micro-manipulator and observation by two microscopes (magnification 40x) arranged at a right angle to each other and to one micrometer screw of the manipulator. Difficulties were encountered by the surface tension of the molten metal spheres. Some of the finer whiskers bent sideways instead of penetrating the surface when they were moved up with the micro-

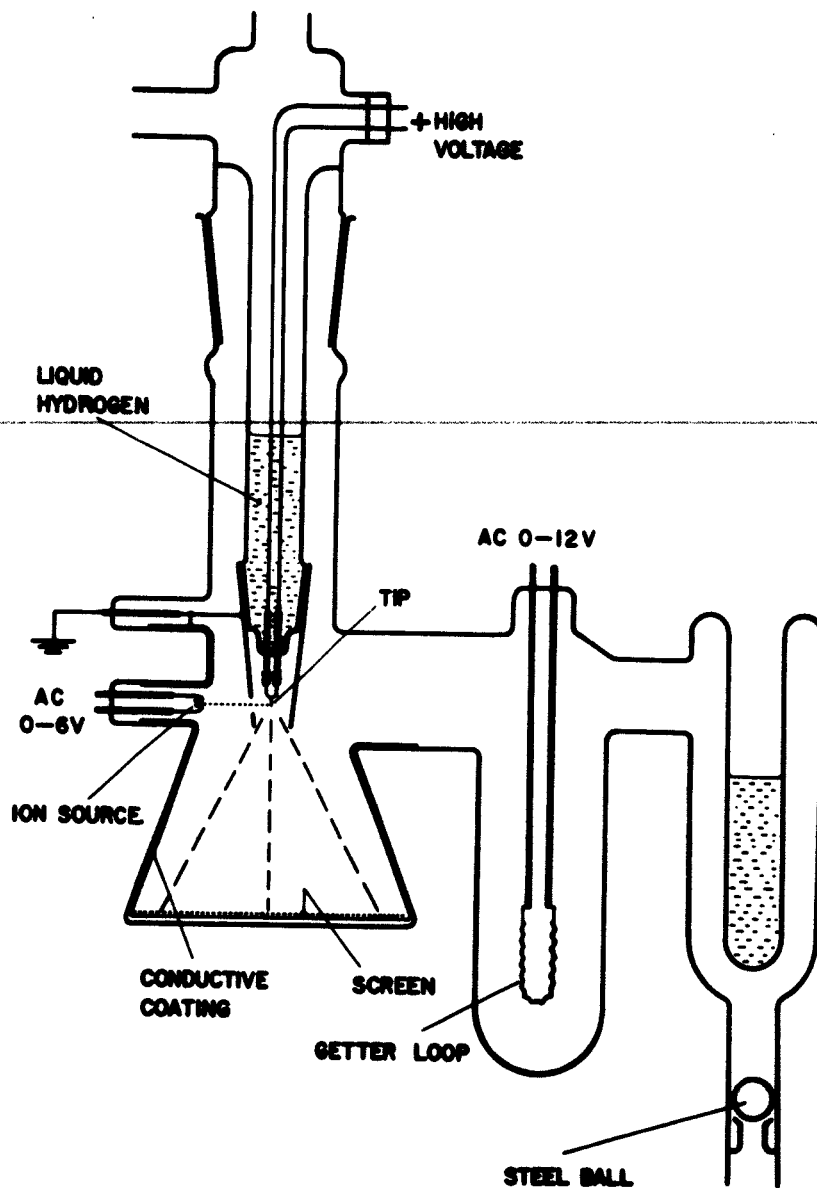

Figure 1. Field Ion Microscope Tube with a Titanium Getter Tube and a Gas Source

manipulator. Another disadvantage of this method is the possibility of contaminating the whisker by the soldering metal, which evaporates at a high rate above its melting point. Gaseous impurities from the metal may also diffuse into the fairly hot whisker.

A new method of mounting was then developed in which the specimen is crimped in a fine metal capillary tube, which in turn is spot-welded to the heater loop. The first experiments were made with nickel tubing of 20 mil outside diameter and 5 mil wall thickness. This worked well for whiskers of 10 to 20 microns diameter. For still finer specimens, the mounting of a whisker by crimping it into a fine platinum capillary tube of .010" outside diameter and .003" wall thickness proved to be a very useful method. The mounting procedure is as follows:

1. Cut the fine platinum capillary tube (10 mil outside diameter, 3 mil hole) to a length of 2 mm by rolling it on a glass plate under a razor blade edge. This method will keep the hole open.
2. Spotweld one end of this capillary on the center of a hair-pin shaped 6 mil tungsten loop which can later be plugged into the field ion microscope.
3. To get a smooth round edge the platinum capillary is etched electrolytically in a molten solution of 99% NaCl and 1% NaNO₂ at a temperature of about 500°C and with 5 to 10 volts dc applied.
4. To remove the salt the loop assembly is washed in running hot water for one hour.
5. The loop assembly is inserted into a hydrogen flushed glass tube. By passing an electrical current through the loop the platinum capillary is annealed for 5 minutes at 1200°C.
6. The clean loop assembly is placed into the loop holder of the special crimping tool as shown in Figure 2. A fine selected whisker is picked up by a magnetic needle mounted on the manipulator of the crimping tool. With this manipulator whose two movements are perpendicular to the viewing direction of the two 40x microscopes the whisker is inserted about 1/2mm deep into the platinum capillary. With the help of the heavy micrometer screw and controlled by the gauge and microscopical observation the soft and smooth edged platinum capillary is crimped by the jaws of the tool to hold the whisker firmly.

With this mounting technique there has never been any difficulty even when the extremely brittle WADD specimens were used. This technique should also be applicable to other delicate specimens such as semi-conductor needles and non-weldable metals.

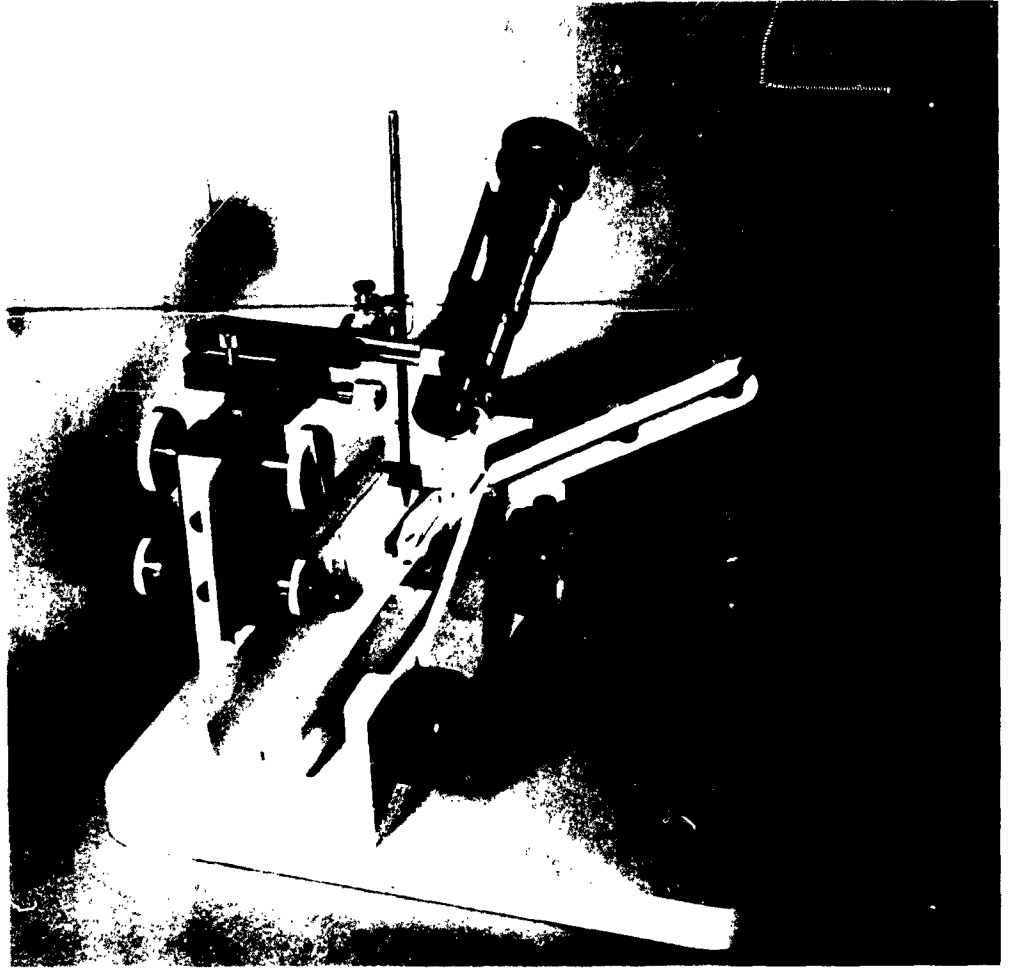

Figure 2. Crimping Tool for Fastening the Fine Whisker Specimen in a Platinum Capillary.

The platinum capillary seems not to affect adversely the electrochemical etching process to which the whiskers have to be submitted after mounting. When anomalies in the etching behavior were encountered, it was shown that the electrochemical potential of platinum was not to blame, as the same effects were occurring when iron capillaries were employed. Platinum would only be objectionable when high temperature treatment of the specimen were intended, as then some diffusion and solid solution of Pt in the specimen could take place.

IV. OBSERVATION OF WHISKER SPECIMENS

A number of experiments were made with samples obtained from Dr. S. Brenner, formerly G. E. Research Laboratory. These are either [001] or [111] oriented, and have diameters between 10 and 100 microns. They exhibit good strength and the pattern shows a fairly good development of high index net planes, indicating high purity. These whiskers are also easily etched to a fine tip.

Figure 3 shows a [001] oriented G. E. whisker having an unclosed horse shoe shaped net plane edge around (001) as reported in the preceding Technical Report. With the continued field evaporation this incomplete central net plane could be removed and the next net edge would again display the horse shoe shape. While the ordinary net planes are evaporated uniformly from the edge of the closed ring, Figure 3a,b,c and d show the completely different process of the field evaporation of such an open ring. Continuous field evaporation of several hundred layers repeated the same process in direction position and shape. Then the whisker was taken out of the microscope, approximately one millimeter of length was etched away, and the specimen was then examined again in the field ion microscope. The unclosed horse shoe shaped net plane edge on the axial (001) plane was still present. This whisker was etched nine times through the whole length of 5mm and tested as described before. Each time it showed the same horse shoe shaped (001) plane.

Figure 4a shows one of the G. E. whiskers which had a screw dislocation emerging at a plane which seems to be (123). The dislocation line could be followed by gradual field evaporation down to a depth of 50 atomic layers, where it disappeared, that is upon further field evaporation the edge of this net plane consisted of close net plane rings.

A number of large whiskers made by G. M. had been supplied through WADD. These are very thick, [111] oriented crystals with a very smooth and shiny surface and hexagonal cross section. They produced a quite regular 3 fold symmetric pattern, indicating a [111] axial direction and high purity (Figure 4b). They are



(a)



(b)

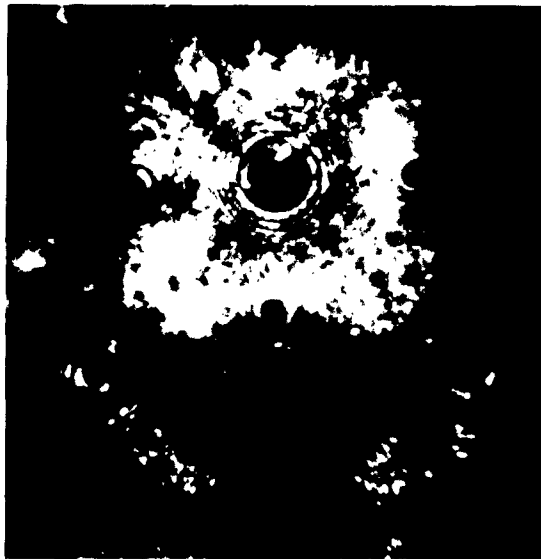

(c)



(d)

Figure 3a,b,c,d. Field Evaporation Process of (001) Plane with Double Screw Dislocation. The Plane in the Center Below is (011) Plane. General Electric Whisker. Helium Ion Image at 16.2kv, Tip at 21°K. Whisker Diameter 42 Microns. Photo No. ON 1293-96

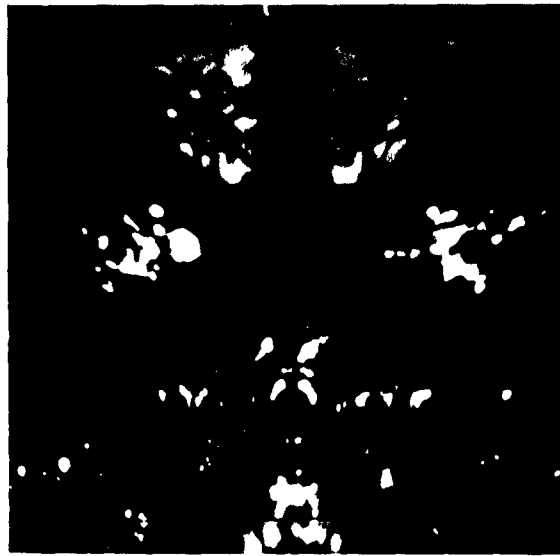

(a)



(b)

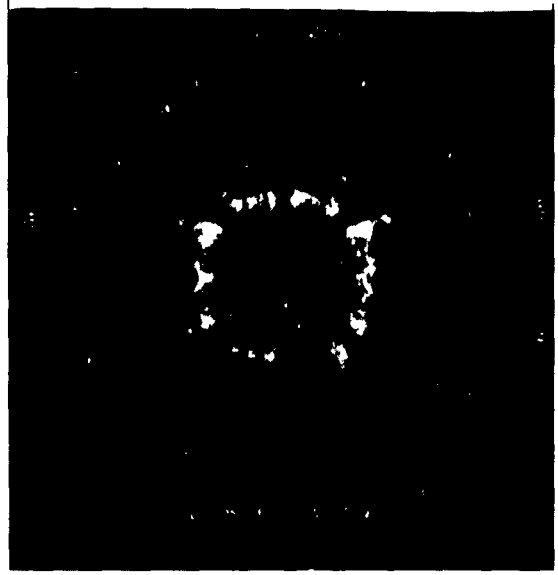

(c)

- Figure 4a. General Electric Whisker with Single Screw Dislocation on (123) Plane. Helium Ion Image at 10.6kv, 21°K. Whisker Diameter 16 Microns. Photo No. ON 1523
- 4b. General Motors Whisker, Original Diameter 300 Microns, Neon Image at 13.0kv, 21°K, $[11\bar{1}]$ Orientation Center. The Three Planes with the Large Net Plane Ring Systems Two-Thirds Toward the Edge are the (011) Planes. There are a Number of Dislocations. Photo No. ON 1339
- 4c. General Motors Whisker. Helium Ion Image at 19.8kv, 21°K, $[00\bar{1}]$ Orientation Center. Photo No. ON 1802

not free of dislocations. The lack of details on the (111) plane itself and also on the $[01\bar{1}]$ zones indicates that these regions have a higher rate of field evaporation than the rest of the surface. These regions probably have a higher work function than most of the surface, contrary to other bcc metals such as tungsten, tantalum and molybdenum.

A new bottle with iron whisker specimens was received through personal contact from General Motors Research Laboratory. They are somewhat smaller than the previous ones which were supplied through WADD, the diameter being between 100 and 300 microns, and the length around 10mm. Their surface quality before and after etching is not so good as previous samples from the same laboratory. These whiskers are $[00\bar{1}]$ oriented. The field ion micrographs show some 20 to 50 fine bright spots irregularly arranged in the vicinity of the (001) plane, which may be large interstitial impurity atoms, Figure 4c.

Figure 5a shows a WADD whisker designated as H-9, M-2. The diameter was 80 microns; after etching, its surface, as seen in an optical microscope, is not very smooth, and it was found difficult to etch really fine tips. The ion images obtained with helium show the large (001) plane in the upper left, and a very indistinct (111) plane in the lower right. Slightly to the left of the center near the bottom is the (101) plane, and in the upper right the (011) plane. This specimen looks fairly perfect, and the reduced image quality compared to ion images of metals such as tungsten or platinum is mostly due to the fact that the imaging voltage was about 10% below the presumably optimum value, in order to prevent field evaporation.

New iron whiskers supplied from WADD in boats designated by T-1, H-86, and H-90 were found to have shiny surfaces, but are usually not straight. However, some of the whiskers showed very clean and smooth surfaces and a perfect tip shape after etching. The whisker diameters were between 10 and 100 microns, and the cross section was hexagonal. Field ion microscopical observation reveals them to be $[11\bar{1}]$ oriented. Their pattern was considerably more regular than the ones obtained from earlier WADD whiskers. Figure 5b shows a WADD H-86 iron whisker with three planes at its original tip, each of which is a rhombus. The field ion image of this whisker depicts small incomplete net planes around the (111) plane, Figure 5c. Figure 5d shows a typical example of an H-90 whisker. These whiskers have a quite regular crystal structure except for the (111) plane. In spite of the high tensile strength of the small dimension whiskers obtained from WADD no satisfactory ion image was observed because all tips broke off when even quite low fields were applied.

The following table shows a comparison of the qualities of the iron whiskers of the same small dimension supplied from WADD and G. E.

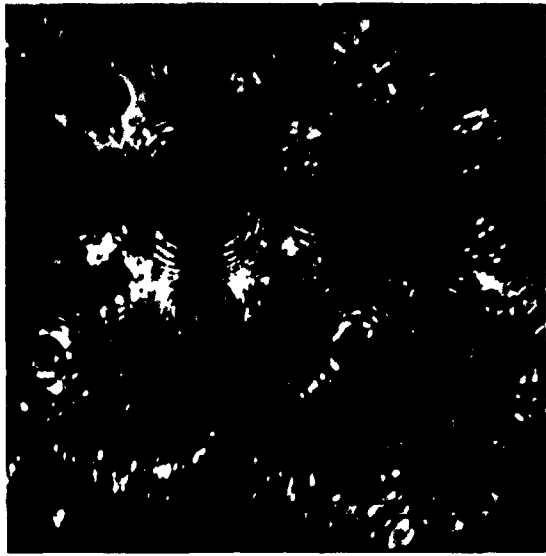

(a)

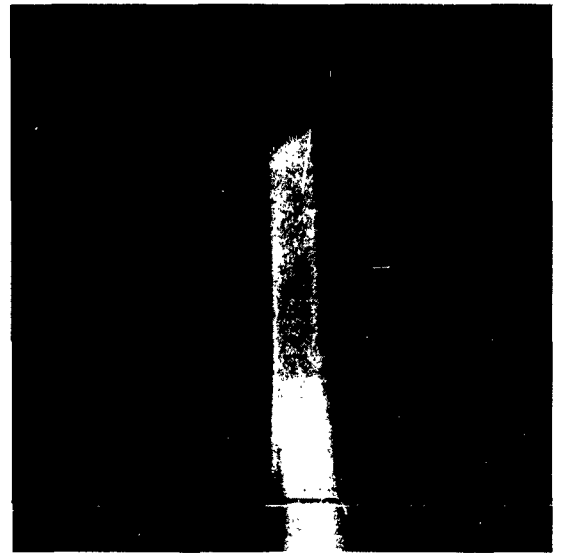

(b)



(c)

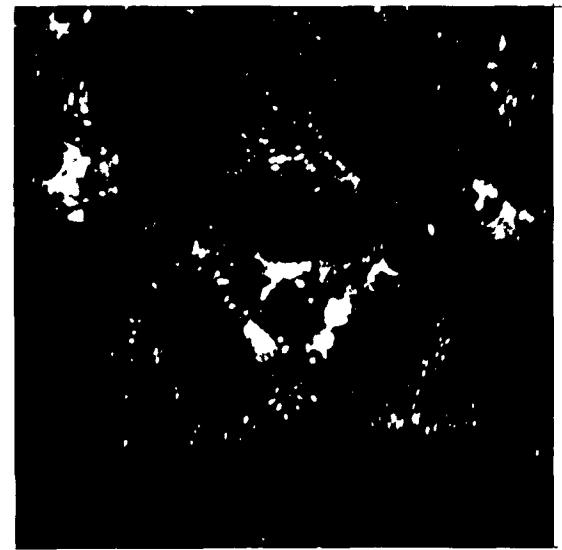

(d)

- Figure 5a. WADD Whisker, Sample H-9, M-2. Whisker Diameter 80 Microns
Helium Ion Image at 12.6kv, 21°K. Photo No. ON 1359
- 5b. Original Tip Shape of WADD H-86 Iron Whisker, Diameter
20 Microns at Tip and 170 Microns at Base.
- 5c. This Whisker is in $[111]$ Orientation, Helium 1.5 Microns
at 21.2kv, 21°K. Photo No. ON 1896
- 5d. WADD H-90 Whisker in $[111]$ Orientation, 100 Microns
Diameter, Helium 1.2 Microns at 13.5kv, 21°K.
Photo No. ON 1973

G. E. Whiskers:

springy

not brittle

cross section
[111] direction 

no etching in 1% to
25% HCl

9 normal HCl, 2-25 volts
dc etching makes fine tips

phosphoric acid does not
etch below 10 volts dc

FIM pattern fairly
regular

WADD Whiskers:

springy

brittle

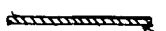
cross section  $\pm 1-2 \mu$
 $5-10 \mu$

no etching in 1% to
25% HCl

9 normal HCl, 4-6 volts dc
produces transparent yellow
oxide sleeves

phosphoric acid at 10 volts dc
dissolves the yellow oxide, a
dull, rough tip cone appears

impossible to obtain any FIM
pattern, as all tips broke off
when even quite low fields were
applied

Some additional work on the behavior of whiskers in the field ion microscope was done with titanium nitride whiskers obtained from Metallgesellschaft in Frankfurt/Main, Germany.

These whiskers have a shiny gold colored surface, are about 2mm long and conical in shape. The thickness is 2 to 10 microns on the thin end, and 50 to 100 microns at the thick end. They etched very well in 40% HF by supplying 1 to 6 volts dc. They were mounted by spotwelding to Ta loops or by crimping them into a fine Pt capillary. The helium ion images were disappointing, not only because of the fast field evaporation rate near best-image-field, but also because of a lack of regularity in the visually observable transient patterns. This indicates that in spite of their smooth appearance they cannot be very pure. Perhaps they are simply non-stoichiometric in composition. It is planned to do some more work on these TiN whiskers, when later some more experience is available with neon as an imaging gas. The importance of this material for the study of whisker growth is that it has a simple cubic lattice, which does not exist in metals.

V. EMITTER SPECIMENS OF PURE IRON WIRES

In order to differentiate between effects which could be expected naturally with iron and effects specific for whiskers of the same metal a number of experiments were performed with emitter tips made of Puron wire, a G. E. made material of 99.5% purity. Figure 6a shows a Puron wire tip in $[011]$ orientation which had not been annealed at all. Various annealing processes were then used to recrystallize the specimen wire of 5 mil thickness, such as (1) annealing just below the transition point (910°C) for a time of 5 minutes to 10 hours, in a good high vacuum, (2) annealing at the same temperature in hydrogen (oxygen removed by palladium catalyst followed by liquid nitrogen cooling), (3) annealing in hydrogen above transition point, (4) annealing in hydrogen above transition point, followed by high vacuum annealing below this temperature. The best results were obtained with the latter procedure, with the annealing temperature 1050°C , where the wire burned out after 30 minutes. The subsequent high vacuum annealing of the newly mounted two halves of the wire was done at 700°C for 5 minutes. The surface of this wire is shiny and smooth, and etching produces fine, well shaped tips. Nevertheless, the field ion image contained many irregularities and defects, there was no regular crystal pattern extending over the entire image cross section. Figure 6b is such an emitter obtained with procedure (3). The explanation of the poor crystal symmetry is probably that this material contained a fairly large number of glissile dislocations which started slip as soon as the field stress was applied. Large chunks of the original crystal hemisphere were torn off by the field forces, leaving behind recessed regions where the local field is too low to make the surface visible in the ion image.

There is still an unexplained discrepancy between the appearance of the iron whiskers in our field ion microscopes and the iron specimens that were observed in this laboratory in 1957². At that time field ion microscopy of iron was not yet attempted, but field evaporation was used to remove surface layers in a controlled way. The resulting tip surface was then viewed by electrons with a limitation in resolution of about 25 \AA . The interesting feature is that the (111) region even of iron specimens of low purity grades (0.3% C) appeared very much more regular than in the present whisker experiments. Figure 6c shows a typical pattern obtained with the alternating field technique. In this technique the field electron microscope is operated with a dc biased alternating high voltage. While the tip voltage is near its positive peak, field evaporation takes place, and in the next phase in which the tip is negative, the tip surface can be observed in its electron image. In this picture the (111) or its immediate vicinity appears bright, indicating either a low work function or a locally enhanced field. The puzzle with our present

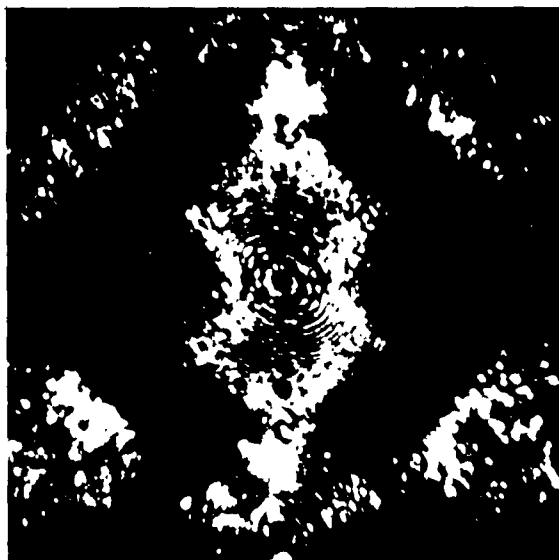

(a)



(b)

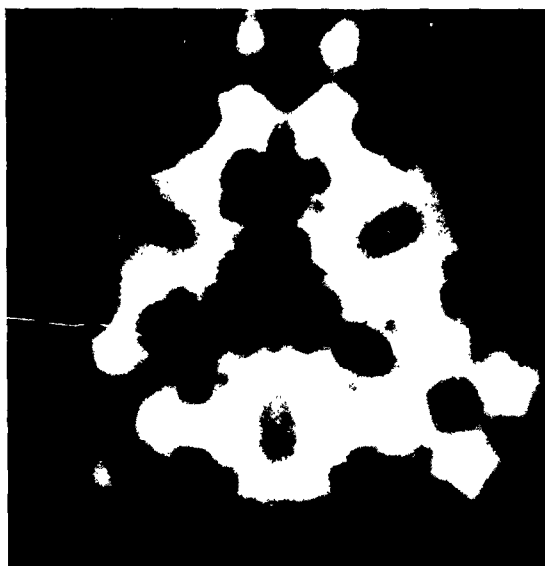

(c)



(d)

- Figure 6a. Puron Wire Tip in $[01\bar{1}]$ Orientation Which Had Not Been Annealed At All. Helium 1.6 Microns at 15.3kv, 21^oK. Photo No. ON 1316
- 6b. Puron Wire Tip in $[01\bar{1}]$ Orientation Which Was Annealed in Hydrogen Above Transition Point. Helium 1.5 Microns at 18.3kv, 21^oK. Photo No. ON 1471
- 6c. Field Electron Image of Iron Wire. Photo No. 39-48
- 6d. Ultra High Vacuum Annealed Puron Wire Tip in $[\bar{1}1\bar{1}]$ Orientation. Helium 1.5 Microns at 24.5kv, 21^oK. Photo No. ON 1831

FIM whisker patterns is that (111) is dark (Figures 4 and 5), that means it is not protruding. The lack of protrusion in a field evaporation end form also indicates absence of low work function. For further investigation of this strange behavior tip specimens were made of highly pure iron wire obtained in the form of "Puron" from General Electric. Puron wire was annealed in a high vacuum tube that was gettered with titanium to obtain a pressure of 10^{-9} to 10^{-10} Torr. The annealing procedure of the 5 mil wire was as follows: Annealing near 1000°C for 3 hours with a weight load of 2g. Then the wire was stretched at room temperature by about 2%. Finally new annealing between 700°C and 850°C followed without a load. Etching of this wire in H_2O 50% + HCl 25% + HNO_3 25% at 6V dc gives perfectly shaped tips with shiny surfaces. The patterns obtained with this material (Figure 6d) are not quite as regular as the ones made previously with the field electron microscope, but they are much better than the ones obtained with not ultra high vacuum annealed Puron samples. It is worth noticing that in spite of some defects near (111) there are some bright ridges on the {233} planes near (111) which resemble closely the bright areas found in the field electron images of Figure 6c.

VI. INFLUENCE OF ADSORPTION ON IRON SPECIMENS

Time delay in the onset of field evaporation was frequently observed when a certain field was applied. Typically there is a steady image obtained immediately after lowering the field by a few percent from the evaporation value. However, after a few seconds field evaporation starts again at this lower value, indicating an inhibition period for a field induced reaction. This could be due to the necessity of surface migration from the shank of the tip underneath the ionization zone, as it was established in this laboratory by the work of J. F. Mulson and E. W. Müller³ for nitrogen and water vapor. In preliminary experiments, however, nitrogen was found to be not active in a field induced reaction with iron, and water vapor should be excluded as we work at 21°K and with highly active titanium getters or charcoal adsorption for purifying the He gas.

Oxygen was suspected as being possibly responsible for the disturbing surface reaction. A source of pure oxygen consisting of an oxygen saturated silver ball of 2mm diameter suspended on a heatable 6 mil Pt loop was built into the microscope so that the tip could "see" the oxygen source. In order to let oxygen approach the emitting tip area, the voltage was temporarily reduced while oxygen was released. However, when after the oxygen adsorption one to three layers of adsorbed or oxidized material was removed by field desorption, the original iron pattern appeared again, and enhanced field evaporation could not be detected.

The bright spots occasionally observed on iron whisker patterns could be places of a particular high local field strength due to the adsorption of positive ions. Such an effect might be responsible for the still unexplained effect of potassium as a "promoter" in the use of iron as a catalyst.

Experiments were made in which potassium ions were evaporated onto an iron tip from a Pt coil which was covered with KOH and then annealed in vacuum. However, the deposit on the tip was found to evaporate at very low field strengths, so that at the best image field for He ions all the potassium ions had disappeared (Figure 7a).

Therefore, potassium ions were released again and the iron tip was heated below red heat about 20 seconds; high field was applied after lowering the tip temperature again. In this case even under the helium image field many bright spots appeared after several irregularly arranged surface layers are evaporated at lower field. They were standing still around (001) plane which faced to the potassium ion source indicating the existence of interstitial atoms on the surface (Figure 7b). The number of these bright spots decreased gradually as the interior of the tip was exposed by continued field evaporation. No bright spots were observed after removal of 150 layers.

This experiment shows that potassium ions do not diffuse into the iron lattice at 21°K but do at about 400°C with a velocity of some 10 atom spacings per second.

One of the more difficult experiments seems to be the study of an effect of hydrogen on the behavior of iron whiskers under high field conditions. WADD whiskers from boat T-1 were used. The supply of extremely pure hydrogen was obtained by arranging inside the microscope a heatable tungsten loop which was coiled with a 6 mil zirconium wire. After thorough out-gassing of this assembly the zirconium was saturated with palladium diffused hydrogen at about 500°C. All the free hydrogen was then pumped out, and a stable He ion image obtained. If now pure H₂ was released by heating the Zr coil to 600°C, fast field evaporation of the iron tip occurred at a field just above half the helium best-image-field. The hydrogen ion pattern itself is quite unusual compared to the He or Ne ion image of the same specimen. A number of protruding atom rows in a direction normal to the net plane steps appears around the {011} planes, when the surface reaction is stopped by reducing the field further. Figure 7c,d show typical patterns of this kind. This strange arrangement of surface atoms might be due to a build up under the influence of field facilitated surface migration.

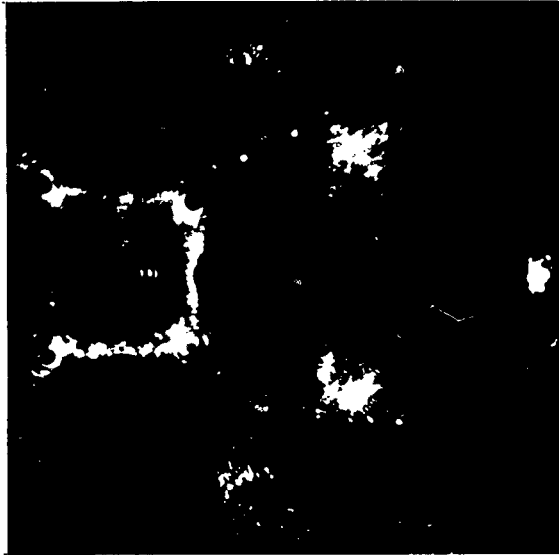

(a)

Figure 7a. Ultra High Vacuum Annealed Puron Wire Tip was First Covered with a Small Amount of Potassium. All Potassium Ions were then Field Desorbed at 21°K. Helium Ion Image at 17.9kv, Tip Temperature 21°K, 1.1 Microns Helium. Photo No. ON 1839

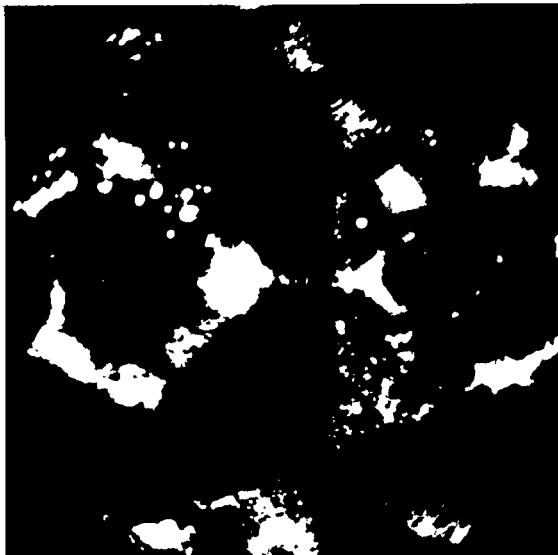

(b)

Figure 7b. Potassium was First Allowed to Diffuse into the Iron by Heating to Approximately 400°C. Subsequent Field Evaporation Exposes the Ions at the New Surface. Helium Ion Image at 21kv, Tip Temperature 21°K, 1.2 Microns Helium. Photo No. ON 1845

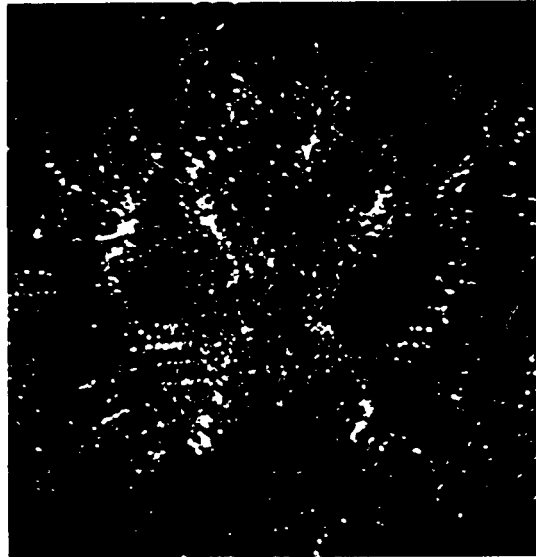

(c)

Figure 7c. WADD T-1 Whiske:
Surface with a Number of
Protruding Atom Rows on it.
Surface due to Hydrogen
Effect. Helium 1 Micron
at 13.5kv, Tip Temperature
21°K. Photo No. 1762

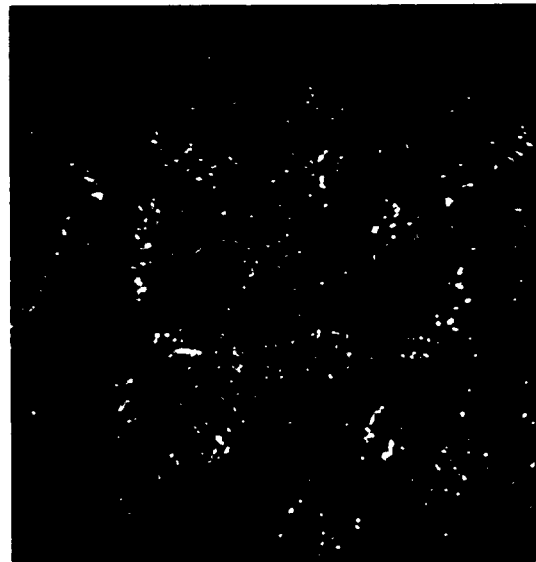

(d)

Figure 7d. WADD T-1 Whiske
Surface with a Number of
Protruding Atom Rows on it
Surface due to Hydrogen
Effect. Helium 1 Micron
at 13.5kv, Tip Temperature
21°K: Photo No. 1763

VII. QUALITY OF THE NEON IMAGE

It was mentioned in the preceding Technical Report¹ that while the neon image quality is far inferior to the one of helium ions because of its low image intensity, large polarizability and strong adsorption at the surface of the iron specimen at a temperature of 21°K, greatly reducing the contrast, it has an advantage in its approximately 10% lower ionization field. However, it is expected that because of its low ionization potential neon can image the tip specimens of easily evaporating metals such as iron, copper and nickel. Also, with its low image contrast neon may depict the regions such as (111) planes and $[011]$ zone lines which are never shown in helium images.

In order to compare the image quality between neon and helium an ordinary tungsten tip was mounted in the FIM because tungsten shows the stable image even at helium best image voltage which would have field evaporated the iron surface. Figure 8a and b show the helium and neon image at liquid nitrogen temperature respectively, indicating the grain boundary around the (121) on the right hand side. The inferiority of the resolution of these pictures compared with the hydrogen cooled image (Figure 8c,d) is due to the higher tip temperature. The neon image shows very good detail and the tip voltage is 9.8kv for neon and 12.5kv for helium. Thus neon requires about 20% lower field which presents a great advantage for the observation of iron and other non-refractory metals. Exposure time for our best photographic equipment described in the preceding Technical Report¹ is 40 minutes for neon and 1 minute for helium. With hydrogen cooling, neon also shows quite acceptable picture quality with slightly less resolution than helium (Figure 8c,d).

From these experiments we can conclude that neon is a promising gas for the observation of easily evaporating metals. In this series WADD H-86 whiskers were used. Figure 9a shows the helium image which does not show the (111) plane and $[011]$ zone lines. On the other hand neon depicts the whole tip surface very clearly indicating that this whisker has a regular crystal structure and very high purity, showing high index net planes except in the (111) plane and $[011]$ zone line regions (Figure 9b). This means that these (111) oriented whiskers might have an amorphous core along their axis. Brenner⁴ found similar cores in his sapphire whiskers, but they were larger as he used only optical microscopy.

In the case of the iron specimen the tip voltage difference for neon and helium is usually less than 10% since the helium image voltage must be kept lower than the best image voltage to get a stable image. For tungsten the difference of image

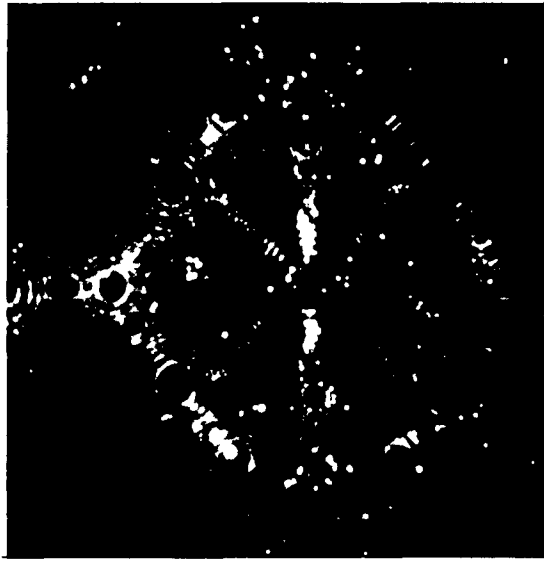

(a)

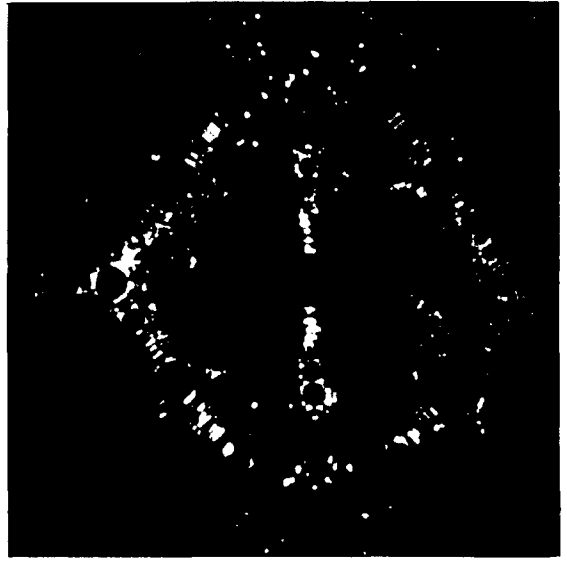

(b)



(c)

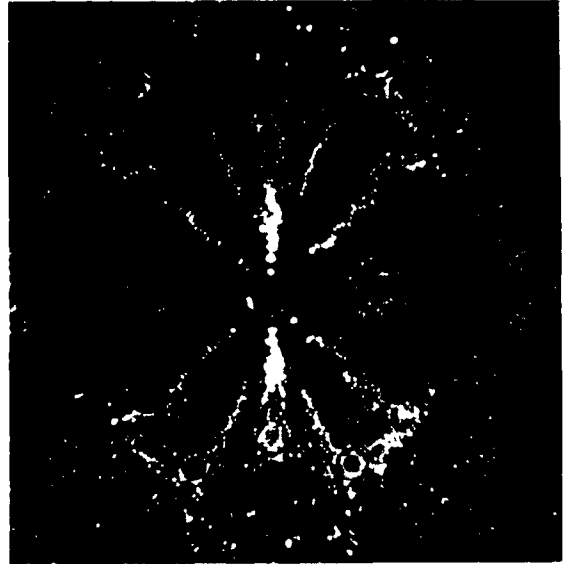

(d)

Figure 8a,b. Neon 0.9 Microns and Helium 1.1 Microns Image of Tungsten Tip at 77°K Respectively. 9.8kv for Neon, 12.5kv for Helium. Photo No. ON 2085, 2087

c,d. Neon 1.2 Microns and Helium 1.2 Microns Image of Tungsten at 21°K Respectively. 10.7kv for Neon 13.6kv for Helium. Photo No. ON 2135, 2134

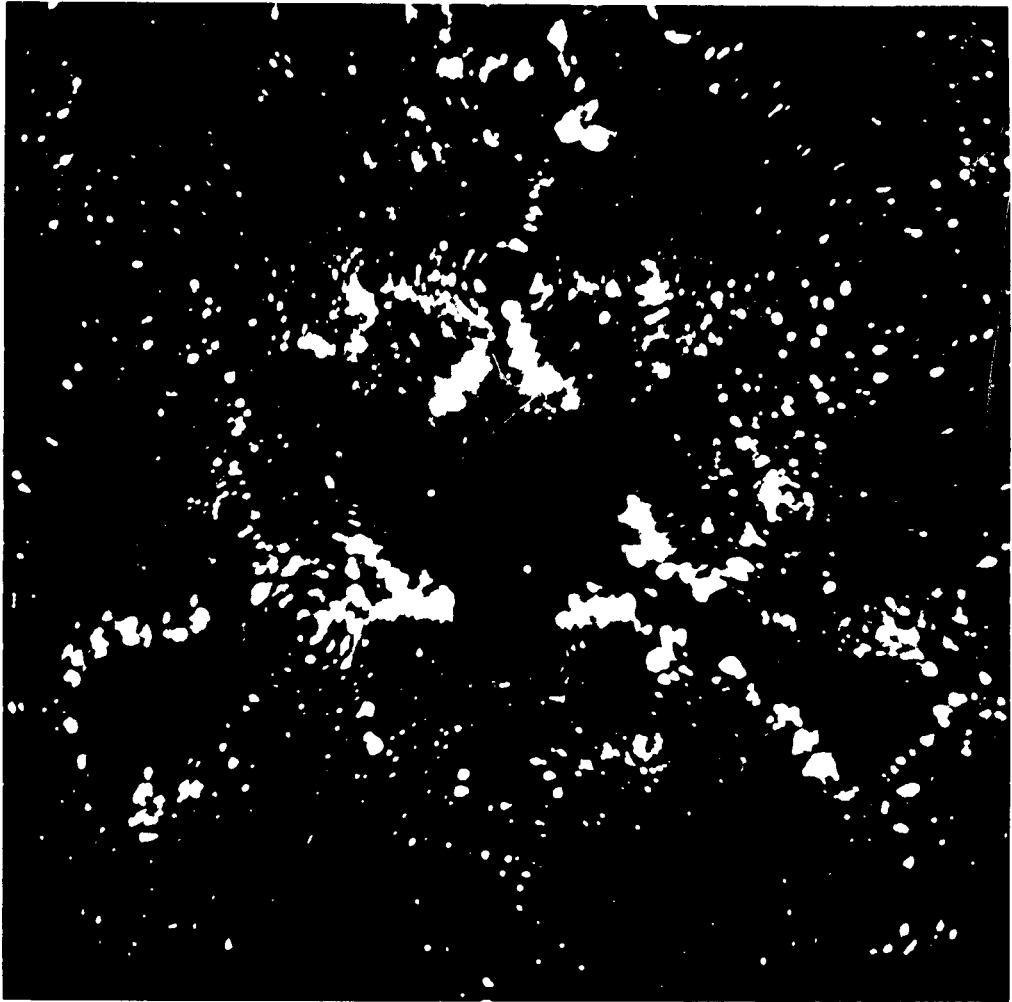

Figure 9a. WADD H-86 Whisker, Helium 1.5 Microns at 17.5kv,
21°K. Photo No. 1958

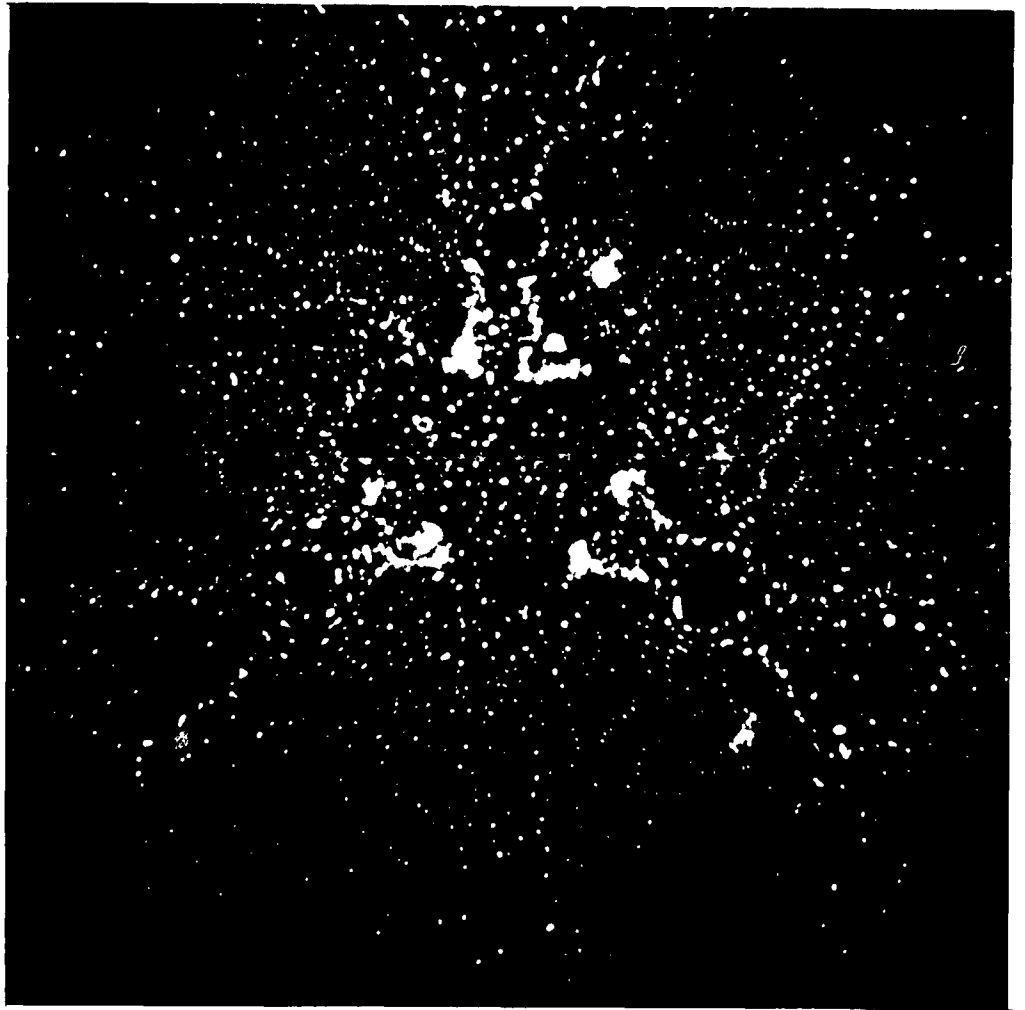

Figure 9b. Neon 1 Micron Image of the Same Tip at 16.5kv,
21°K. Photo No. 1952

contrast between neon and helium is not large because neon does not adsorb on it. However, on the iron specimen surface neon seems to have a tendency to be adsorbed at 21°K thereby lowering the image contrast and decreasing the hopping height. Therefore the image pattern differs largely for neon and helium as shown in Figure 9. To adjust the hopping height of neon on the iron surface the tip was heated up to about 40°K. Then the image became about 10% brighter, but field evaporation started gradually. Considerable progress with the use of neon as imaging gas can be expected with the application of an electronic image amplifier, which we hope to have available in the near future.

VIII. CONCLUSION

From the experience with the different specimens described above it is concluded that the iron lattice is considerably more sensitive to very small impurity levels than are the more refractory metals.

From the experiments with Puron iron tips it is confirmed that iron is an extremely difficult material to handle with the FIM because of the strong tendency to pick up contaminations, and because of the low yield stress when many dislocations are present. On the other hand, the experience with some good whiskers has shown that quite perfect crystal patterns with good atomic detail can be obtained, occasionally with a pair of screw dislocations. Those WADD whiskers which could be observed so far displayed a high degree of imperfection and disorder. From our FIM observations and from our studies of the irregular etching behavior we are inclined to ascribe the high tensile strength of the WADD whiskers to a hardening due to a network of sessile dislocations rather than to a nearly dislocation free structure. These whiskers also seem to contain many impurities which may block the motion of dislocation sources, and consequently of slip. The brittleness is difficult to understand. We have also no detailed explanation for the fact that the recent WADD whiskers which have been successfully subjected to high tensile stresses (at room temperature) all break off in the FIM. The temperature of the ductile-brittle transition should be measured. The break does not take place near the tip where the electrostatic field stress is high, but rather way down on the shank. It looks as if a low strength crack has developed through the entire cross section of the tip.

The future work will emphasize the requirement of extreme cleanliness of specimen preparation and purity of the imaging gas. It is strongly suspected that hydrogen from the growing

process is present inside the lattice in fairly high concentration, and it might be useful to try to remove some of this impurity by ultra high vacuum annealing.

The unexpectedly good resolution of the neon image gives promise for future work. The conditions for obtaining the best resolution will be established for tungsten, iron and other metals at various temperatures. Also, observation with helium at solid hydrogen temperature, 15°K, will be tried because there is some evidence that a wider margin between evaporation field and image field⁵ can be obtained by using larger tip radii, between 1000 and 2500 Å. This may require the use of lower temperatures than the presently applied 21°K, in order to retain the full resolution. Pumping on the liquid hydrogen cold finger or using liquid helium for cooling will be considered. Mixed gas of helium and neon might be helpful because at the regions where the local tip radius is small, or the electric field is high, helium has best image condition, while neon will image the low field regions. However, the large difference of intensity of the two gases is a problem. Optimizing relative and total gas pressures and the temperature are now under investigation. After the best operational conditions are established this will be a great help in the investigation of the iron whisker surface structure in atomic details.

IX. LIST OF REFERENCES

1. Müller, Erwin W., WADD Technical Report 60-534
2. Cooper, E. C. and Müller, E. W., Rev. Sci. Instr. 29, 309, 1958
AFOSR-TN-57-738
3. Mulson, J. F. and Müller, E. W., Technical Report AFOSR-1910
4. Brenner, S. S., J. Appl. Phys. 33, 33, 1962
5. Müller, E. W. and Young, R. D., J. Appl. Phys. 32, 2425, 1961

1. Ion microscopy
2. Iron whiskers
I. AISC Project 7353,
Task 7353.4
II. Contract AF 33(616)
-6997
III. Pennsylvania State
Univ., University
Park, Pa.
IV. Erwin Miller,
Osamu Nishikawa
V. Avail fr OTS
VI. In ASTIA collec-
tion

Aeronautical Systems Division, AF Materials
Lab, Metals and Ceramics Division,
Wright-Patterson AFB, Ohio.
Rpt Nr ASD-TDR-69-138. FIELD ION MICROSCOPY
OF IRON WHISKERS. Final report, May 63, 24p.
incl illus., 5 refs.
Unclassified Report

The field ion microscope images of iron
whiskers from various origins were observed
and differentiations between iron whiskers
and specimens made of pure iron wire were
studied. Indications of crystal defects such
as screw dislocations and axial disordered
core structures were found. The influence of
various cases on the iron surface under the

(over)

extremely high electric field and the dif-
fusion of potassium ions into the iron lat-
tice was observed. The operation of the field
ion microscope with neon gas gives certain
advantages for the study of easily field
evaporating metals such as iron.

1. Ion microscopy
2. Iron whiskers
I. AISC Project 7353,
Task 7353.4
II. Contract AF 33(616)
-6997
III. Pennsylvania State
Univ., University
Park, Pa.
IV. Erwin Miller,
Osamu Nishikawa
V. Avail fr OTS
VI. In ASTIA collec-
tion

Aeronautical Systems Division, AF Materials
Lab, Metals and Ceramics Division,
Wright-Patterson AFB, Ohio.
Rpt Nr ASD-TDR-69-138. FIELD ION MICROSCOPY
OF IRON WHISKERS. Final report, May 63, 24p.
incl illus., 5 refs.
Unclassified Report

extremely high electric field and the dif-
fusion of potassium ions into the iron lat-
tice was observed. The operation of the field
ion microscope with neon gas gives certain
advantages for the study of easily field
evaporating metals such as iron.

(over)