

UNCLASSIFIED

AD **409 098**

DEFENSE DOCUMENTATION CENTER

FOR

SCIENTIFIC AND TECHNICAL INFORMATION

CAMERON STATION, ALEXANDRIA, VIRGINIA



UNCLASSIFIED

NOTICE: When government or other drawings, specifications or other data are used for any purpose other than in connection with a definitely related government procurement operation, the U. S. Government thereby incurs no responsibility, nor any obligation whatsoever; and the fact that the Government may have formulated, furnished, or in any way supplied the said drawings, specifications, or other data is not to be regarded by implication or otherwise as in any manner licensing the holder or any other person or corporation, or conveying any rights or permission to manufacture, use or sell any patented invention that may in any way be related thereto.

CATALOGED BY DDC 409098

AS AD NO.

409 098

N-63-1-2

UNIVERSITY COLLEGE LONDON
Gower Street, London W.C.1.

Final Technical Report No. 1, 1 December 1962

One-Dimensional X-ray Diffraction Techniques
as a Routine Stereo-Chemical Tool.

Contract Number DA-91-591-EUC-2063
with the United States Department of Army
through its European Research Office
1 December 1961 to 30 November 1962.

by R.S. Nyholm
Peter Pauling
G.B. Robertson
Jean Dollimore

DDC
REPRODUCTION
JUL 10 1963
TRAV B

The research reported in this document has been made possible through the support and sponsorship of the U.S. Department of Army, through its European Research Office.

ASTIA AVAILABILITY NOTICE
CHECK FOR THE
OF THIS DOCUMENT

U N I V E R S I T Y C O L L E G E L O N D O N

Gower Street, London W.C.1.

Final Technical Report No. 1, 1 December 1962

One-Dimensional X-ray Diffraction Techniques
as a Routine Stereo-Chemical Tool.

Contract Number DA-91-591-EUC-2063

with the United States Department of Army
through its European Research Office
1 December 1961 to 30 November 1962.

by R.S. Nyholm
Peter Pauling
G.B. Robertson
Jean Dollimore

The research reported in this document has been made possible through the support and sponsorship of the U.S. Department of Army, through its European Research Office.

INDEX

	<u>Page</u>
Summary	3
1. The Problem	5
a) Introduction	5
b) Desired information on the nature of substances	5
c) Information available from one-dimensional diffraction data	9
d) Application of c) to b)	11
2. Facilities	13
a) Photographic techniques	13
b) The Powder/Liquid Diffractometer	14
3. The Structural Information Determined	22
a) $TiCl_4 \cdot D_2$ and its isomorphs	22
b) $Co \cdot (Ph_2CH_2AsO)_4 \cdot (ClO_4)_2 \cdot (NO_2)_2$ and $(ClO_4)(NO_2)$ (with Mr. Gordon Redley)	23
c) $Zr(acac)_2Cl$ and $Zr(acac)_2Cl \cdot H_2O$	26
d) $Br(Quinoline)_2ClO_4$	27
e) $NiBr_2 \cdot 2,5$ dimethyl pyrazine (with Professor F.D. Ayres)	30

	<u>Page</u>
f) $\text{KPt}(\text{scac})_2\text{Cl}$ (with Dr. R. Mason)	31
g) $\text{KPt}(\text{scac})_2$	36
h) $\text{Cr}_2 \text{Ac}_2 (\text{OH})_2 \text{Cl} \cdot 8\text{H}_2\text{O}$ (with Dr. B.N. Figgis)	37
j) $\text{Ni}(\text{Ph}_3\text{FO})_4 (\text{ClO}_4)_2$ (with Dr. B.N. Figgis)	38
4. Proposal for the use of the ATLAS computer for crystallographers	41
5. Plan of future work	48
6. Administration including expenses	49

Summary

^{WAS}
The objective of ~~this investigation~~ is to develop and evaluate techniques for obtaining information on the structure of molecules by use of one dimensional x-ray diffraction data from powders, solutions and liquids and to obtain information on the structure of molecules.

~~To these ends we have been studying~~ the technique of collecting one dimensional diffraction data and the numerical treatment of such data for interpretation and comparison ^{with} similar observed data from a series of compounds and with corresponding functions calculated from proposed structural models. ~~We have prepared rather elaborate computer programs~~ ^{to treat} observed data and to calculate the necessary functions. ~~We have designed and are presently constructing~~ a fully automatic diffractometer for powders, liquids and solutions ^{to collect} high quality one dimensional diffraction data easily and rapidly and present it in digital form for direct reading by a digital computer.

We have also done a fair amount of analysis of molecular structure by single crystal diffraction techniques.

The structures of the compounds potassium bisacetyl-acetone chloro platinum II (with Dr. R. Mason) and dichloro 2,5 dimethylpyrazine Ni II (with Professor F.D. Ayres) have been determined completely and refined. The structure of titanium (IV) bisdiarsine tetrachloride has been determined (as reported in FTR 1, 1 November 1962) a fairly large amount of additional data have been collected and the structure is

in the process of being refined. Three dimensional data has been collected and processed for the compound Bromine bis-quinolineperchlorate (with Dr. R.G. Tonkyn) and most of the structure has been determined from the three dimensional sharpened Patterson function. Three dimensional data has been collected, processed and the sharpened Patterson function calculated for the compounds tetra diphenylmethyl arsine-oxide cobalt (II) diperchlorate (with Mr. G. Rodley) and hexaacetate dihydroxy chloro trichromium (with Dr. B.M. Figgis). The structure analysis of these compounds should now be straightforward. Unitcell symmetry and sizes have been determined for the compounds $Zr(acac)_3Cl$, $Zr(acac)_3Cl \cdot H_2O$, $KPt(acac)_3$ and we expect to do more work on these compounds.

Since we spend so much of our time using computers, we have made certain proposals for the arrangement of programmes in the new University of London Atlas computer and are developing these and attempting to get agreement and the adoption of certain conventions.

1. The Problem

a) Introduction

The object of this investigation is to develop and evaluate techniques for determining as much information on the structure of molecules as possible by use of one dimensional x-ray diffraction data. Structures are three dimensional and diffraction data from powders, solutions and liquids is one dimensional. Consequently it is seldom that unequivocal information can be determined from such data about a single substance. Comparison of functions derived from such data for various compounds of known and unknown structure and with equivalent functions calculated for proposed structural models can, however, lead, we hope easily and rapidly, to the determination of a certain amount of structural information.

b) Desired information on the structure of compounds

Given the number of ligands attached to a central metal atom (the coordination number), there are three main kinds of information concerning the structure of compounds of interest to us: (i) interatomic distances, (ii) interatomic angles and (iii) molecular conformation. Thus, in the case of a complex of the general formula $MCl_2 \cdot 2\text{pyridine}$, one first wishes to know whether the metal atom is four-coordinate or six-coordinate, in the latter instance via halogen bridging forming an infinite polymeric structure. Given that the compound is monomeric and hence four-coordinate, one wishes to know whether the bonds are arranged so as to form a square or a tetrahedron of atoms around the central metal atom. There

remains the need for data about interatomic distances, so as to enable one to infer something about the nature of the chemical bonding involved. Finally one wishes to know the conformation of the molecule or complex ion as a whole.

A wide range of physical methods have been developed and applied to inorganic compounds during the past few years to enable one to infer the structure of molecules. Traditional methods involving thermodynamic activities of the substance dissolved in a suitable solvent lead to molecular weights; similarly electrical conductivity studies on solutions and melts yield complementary information. More recently one has seen the wide-spread application of the measurement of infra-red, visible and ultraviolet spectra for structural purposes as well as the use of electric dipole moment and magnetic susceptibility measurements. Other spectra techniques include nuclear magnetic resonance and electron spin resonance methods. The definitive and unfortunately the most time consuming technique, however, is the method of x-ray analysis. Where possible, the x-ray method must be regarded as the final arbiter of structure.

The time taken for many single structures forces one either to limit the number of structures which can be determined in a given time or to look for modifications of standard x-ray techniques which will enable one to obtain a certain minimum of essential structural information quickly. In the study of coordination compounds, this minimum structural

information would be the coordination number and stereochemistry of the central metal atom only with perhaps limited accuracy and without knowledge of the other atoms present.

The physical techniques other than x-ray methods mentioned above do indeed give a good deal of reliable information but constantly one finds unexpected results when a full x-ray study is made. Thus in 1939 (L. Pauling, *The Nature of the Chemical Bond*, 2nd Edition, Cornell University Press (1940)) it was generally assumed that in bivalent nickel, palladium and platinum compounds diamagnetism was diagnostic of a square co-planar four-coordinate metal II complex whereas paramagnetism with two unpaired electron spins indicated either an octahedral or a tetrahedral arrangement. It is now known from x-ray diffraction studies that quite a number of diamagnetic nickel II compounds are in fact five-coordinate (for example $\text{NiBr}_2 \cdot \text{Triarsine}$ (G.A. Barclay, R.S. Nyholm and R.V. Parrish, *J. Chem. Soc.*, 4433 (1961)) which is square pyramidal) or, in the case of Pd, six-coordinate (for example $\text{PdI}_2 \cdot 2\text{Diarsine}$ which is tetragonally coordinated) (C.M. Harris, R.S. Nyholm and N.C. Stephenson *Nature*, 177, 1127 (1956)). On the other hand, it was only recently that tetrahedrally coordinated bivalent nickel was established in the compounds $\text{NiBr}_2 \cdot 2\text{Ph}_3\text{P}$ (L.M. Venanzi, *Proc. Chem. Soc.*, 6 (1958)) and $(\text{Ph}_3\text{MeAs})_2\text{NiCl}_4$ (N. Gill, R.S. Nyholm and Peter Pauling, *Nature*, 182, 168 (1958)).

Several groups of compounds have been prepared recently

in these laboratories for which a certain amount of structural information is required, in particular the arrangement of metal atoms and their coordinated ligands, and for which an unambiguous structure assignment has not been possible by the usual physical chemical non-diffraction methods. Several of these groups have been partially examined by the techniques involved in this investigation.

A series of compounds of the form $(M_3(CH_3COO)_6(OH)_2)Cl \cdot 8H_2O$ where M is iron III or chromium III and similar compounds have been prepared by Mr. A. Earnshaw and the magnetic properties of these compounds cannot be understood without knowledge of the atomic arrangement. A structure has been predicted (L. Orgel, Nature, 187, 504 (1960)) but cannot be confirmed without a diffraction study. In collaboration with Dr. B.N. Figgis of these laboratories we are in the process of determining this structure completely by single crystal diffraction methods as reported in detail later in this Report.

Many workers in these laboratories have, since 1950, prepared a large number of compounds of the general form $(MX_2 \cdot 2Diarsine)Y$, or $(MX_2 \cdot 2Diarsine)Y_2$ where M is a divalent metal, Diarsine is *o*-phenylenebisdimethylarsine, X a halide and Y an anion and wish to know whether these compounds are cis or trans octahedral complexes or perhaps tetragonally or otherwise distorted from an octahedral arrangement of ligands.

Dr. N. Gill has prepared a series of compounds of transition metals of the form $MX_2 \cdot 2\text{pyridine}$ where X is a halide. The possible arrangements of the ligands about the metal atom are octahedral, tetragonal, square or tetrahedral. Theoretical predictions of the expected coordination have been made, and the structures inferred from the absorption spectra and magnetic susceptibilities of the compounds. The actual structures cannot be known for sure without quantitative diffraction studies nor can correlations between the physical properties of the substances with the atomic structure be made.

c) Information available from one dimensional diffraction data

The x-ray diffraction pattern of a crystalline powder, a gaseous, liquid or amorphous material must have spherical symmetry, i.e. it is a one dimensional function. One can directly obtain only one dimensional structural information from such a diffraction pattern, that is, only information about the distances between atoms but not directly about their relative orientation except in so far as this affects distances. The diffraction pattern can be obtained photographically in a suitable camera or measured directly with some sort of photon counter. The Fourier transform of the data so obtained can be calculated with no assumptions about the structure of the substance involved, and in some cases, this Fourier transform, or radial distribution curve, can be interpreted in terms of the atomic structure of the substance. We shall

use the term "intensity distribution curve" (IDC) to refer to the diffraction pattern of a substance (in reciprocal space) whether observed or calculated and the term "radial distribution curve" (RDC) to refer to real space functions, whether derived from the atomic structure or the Fourier transform of the observed intensity distribution curve.

The radial distribution curve represents the average environment of the average atom of the substance (where the average refers to the electron density or atomic number of the atom) and must be interpreted in terms of structure as such. Often the number of structural parameters exceeds the number of data available, and a unique interpretation cannot be made. This is because the structure involves orientation and distances whereas the RDC gives information only about distances. None the less, if a trial structural model can be proposed, the radial distribution curve of the model can readily be calculated and compared with that obtained from the observed diffraction data. If the two curves agree well, the model is likely to be correct, or, alternatively, it may be possible to show that a proposed model or groups of models does not agree with the observed data.

The radial distribution curve can be modified in various ways; the intensity distribution curve may be divided by the sum of the squares of the atomic scattering factors to produce the average environment of the average atom in terms of atoms instead of in terms of electron density. The sum

of the squares of the atomic scattering factors should be subtracted from intensity distribution curve (equivalent to removing the origin peak from the Patterson function) but this requires knowing the absolute scale of the IDC.

The intensity distribution curve itself cannot be interpreted in physical terms, but some investigators consider the comparison of observed and calculated IDC's a more sensitive test of the correctness of a proposed model than the comparison of RDC's. We do not yet know if this is generally true.

d) The application of one dimensional diffraction data to coordination chemistry

The RDC is often difficult to interpret. It represents the average environment of the average atom in terms of atomic number and consequently in those problems in which the atom of major interest has a large atomic number, the RDC is weighted to show information about the heavy atom. This is often the case in the study of coordination compounds. Furthermore, often the ligands, e.g. arsenic, have a high atomic number, and in these cases the metal-arsenic and arsenic-arsenic interactions will appear strongly in the RDC. In addition, the study of coordination compounds usually involves the study of many similar compounds in which the coordinated metal atom is changed, for example from Cr to Mo or W, and/or where the ligands are changed, for example from Cl to Br or I. In these cases, by comparison

of the RDC's from the several compounds, the peaks corresponding to interactions between the atoms which are changed and themselves and the other atoms will change, allowing an unambiguous interpretation of these interactions.

In those cases where several compounds are available are where the atoms of major interest are of high atomic number, the application of the RDC method should readily give a good deal of stereochemical information. The information is not definitive, that is, it is open to alternative interpretations, but the technique should in favourable cases be at least as valuable as the indirect physical methods currently used. The success of the general use of the methods, given suitable compounds, is the availability of an easily used procedure for obtaining the data and treating it numerically.

2. Facilities

a) Photographic Techniques

We have been using a Philips 114.83 mm. diameter collimated powder camera to collect our diffraction data. The camera is of the Debye Scherrer type with the Straumanis film arrangement and with collimated beam. This camera is convenient to use but suffers a number of disadvantages for our work. The signal to noise ratio is low, primarily because the acceptance bandwidth of photographic film is wide. The data is in an inconvenient analogue form as blackening on a film. The process to convert this data into a form suitable for computation is tedious and liable to error. Except in some cases where we already have available data from this camera, for the purposes of using the radial distribution curve, we have given up collecting data with this type of camera.

Certain objections to the above camera can be overcome by using a Guinier de Wolff focussing monochromator camera. This type has a much improved signal to noise ratio due to the monochromator. The improvement in dispersion is not of primary importance in RDC work because the ^{exact} positions of the lines do not matter; only the average intensity is used. The data still appear in analogue form on a photographic film and the disadvantages mentioned above apply here too. We are endeavoring to obtain money to purchase such a camera primarily to enable us to obtain qualitative

comparative data.

b) The Powder/Liquid Diffractometer

We have designed an automatic diffractometer to collect one dimensional diffraction data of high quality rapidly and easily from powders and amorphous solids, liquids and solutions. The instrument uses the Bragg Brentano focussing geometry with stationary sample and x-ray tube and detector mounted on two rotary tables coupled equally and oppositely. This geometric arrangement is particularly convenient for use with liquids, melts and solutions. High quality data is expected by the use of accurate geometry using Soller slits, post diffraction bent crystal monochromator and scintillation counter and pulse height analyser. The data are produced as digital information on punched paper tape for direct reading by computer. A control box built of plug-in logical blocks controls the counting, punching and advance theta circuits.

Several modes of operation are available with the instrument. To obtain qualitative information fairly rapidly the diffraction angle can scan at constant rate and the logarithm of the detected pulse rate recorded on a synchronous chart pen recorder.

The primary operational mode involves the recording of the digital count. The instrument will count for a fixed time (or monitor count; the terms are equivalent as used here), fixed count, or both. The count will terminate if

either register overflows. In addition if after a set time the count has not reached a set amount, the count will terminate, either proceeding to punch the angle and counts or to advance the angle without punching. The least significant digit of the last interval in theta, the present value of theta, the monitor and main counts are punched on paper tape, separated by spaces and terminated by carriage return and line feed. The angle theta is advanced by either of two set amounts between 0.01° and 9.99° depending on either the last count being above a set amount or upon the most significant digit of theta being above a set amount. There is no facility for the machine to back up under automatic control. Variations in the mode of operation are set by combinations of switches and a patch plug board. As many as possible logical connections such as start and end of operation signals, reset, register inputs, monitor or time pulses, are made through the patch board to allow for flexibility in operation. The instrument has been designed to allow convenient manual operation if desired.

The mechanical instrument is a copy of the device built and used by H.A. Levy and colleagues at the Oak Ridge National Laboratory. It consists of two rotary tables mounted with their axes coincident and horizontal. An x-ray tube and incident slit system is mounted on one and the receptor slit system, crystal monochromator and scintillation detector mounted on the other. The two rotary tables are linked to

each other so that they rotate equally and in opposite directions. The rotary tables are 90:1 worm gears and are linked to the common drive shaft by 100:1 worm gears. A synchronous motor drives this shaft through a three speed gear box.

The sample is stationary and horizontal. In order to overcome the effects of preferred orientation in powdered samples, two modes of sample rotation will be available. One is to make the sample cylindrical and to rotate it about the axis of the instrument and the other is to make it flat and to rotate it about the axis of the reflecting planes by using the Philips accessory for flat sample reaction.

An atmospheric sealed heater and cooler for the sample is being made as a copy of the furnace used at Oak Ridge. This will allow a temperature range from about liquid nitrogen to about 1000°C.

The diffraction geometry is that of Bragg and Brentano, symmetrical at the sample. It involves source and defining slits with side divergence limited by Soller slits. The receiving geometry is similarly defined by two slits and a Soller slit and has in addition a bent crystal monochromator. Use of this crystal monochromator is the primary technique for obtaining data of high signal to noise ratio.

The detector system consists of a scintillation counter and photomultiplier, stable high voltage supply, White

cathode follower, linear high stability amplifier, single channel pulse height amplifier, logarithmic ratemeter, pen recorder and five digit counter. The counter is built as part of the automatic control system.

The x-ray source is kept at constant (0.1%) voltage and current (Philips PW 1010) and is monitored by picking up a constant fraction of the incident x-ray beam diffracted by an inserted aluminium sheet with a Geiger counter. The Geiger counter is recorded on a 5 digit counter. If preferred 100 pps and 50 pps generated by the electricity main supply can be counted instead of random monitor pulses.

The control system has been designed in terms of the plug-in logical blocks developed by the English Electric Company Ltd. for use in their industrial control system. The diffractometer uses about 300 logical elements in 67 packages in five 7" bins. The control circuit is in three parts, the counting circuit, the punching circuit and the advance theta circuit which are connected to each other through a patch plug board.

The advance theta circuit involves a bistable element to indicate the operation on,

two switches to control direction, a four decimal digit reversible counter to indicate the value of theta and a three digit counter and associated switches and recognition circuits to control the interval of theta

advance. The pulses indicating intervals of 0.01° change in theta are derived from a 4 slit chopper mounted rigidly on the drive shaft to the rotary tables, a lamp, phototransistor and amplifier. These are fed directly to the two registers. The theta register is not automatically reset and counts up or down as controlled by the direction switches, manual and automatic (13,14). Since the theta register must initially be set to the Bragg angle of the instrument, this can be done via four ten position switches (31 to 34) and a push button (30) and the value of this register is indicated on four decimal indicators. The delta theta register counts pulses until the register has coincidence with a set of switches indicating the desired interval. There are two such sets of switches (5,6); whether one (6) is valid or not depends on the state of another bistable register which can be set by, for example, a set minimum count (10). This facility is expected to be of use with powdered samples to save time. When coincidence is reached, the circuit turns itself off and supplies a next operation pulse through delay elements. Operation of the drive is through a clutch and brake with operation times of about 10 msec. Provision to stop the motor is made in order to prevent vibration of liquid samples from disturbing the measurement.

The counting circuit consists of a bistable element to indicate that the operation is on, two five digit binary coded decimal (1242) counters, a number of switches to pick

up the signal when the counters have reached set values, and a few logical elements. The possible numbers that the circuit can recognise for its operation is limited to 40, 80, 100, 200, 400, 800, 1000, 2000, 4000, 8000, 10000, 20000, 40000 and 80000.

A second bistable element remembers whether the count has passed a set amount by the time a set time has passed for the ignore facility. The AND/OR set time set count is controlled by switch 9 and the set time and set count by switches 7 and 8. The end of operation pulses for the ignore and valid counts are separate allowing separate subsequent operations and are fed through delay elements as pulse shapers.

The punching circuit involves a bistable element to indicate the operation on, a 32 stable state character count (of which 29 are used), a 5 to 32 diode matrix to decode this count, 18 data gates to transfer the 18 independent data sources to the punch, a 1242 to 1248 code converter, odd parity generator and amplifiers for the tape punch solenoids. A delay element putting a level on the suspension line of the matrix and on the trip coil of the punch for 25 msec. sets the conditions for the operation of the punch. A signal back from the punch at the end of the cycle advances the character count by one and starts the cycle again. At the end of the whole punching cycle, a pulse from the character count register turns off the control register via a delay and provides an end of cycle pulse via another delay for the next operation.

All end of operation signals and all input signals supplying resets pulses are via double delay elements allowing for complete freedom in connecting operations to each other and allowing an element to reset itself either immediately before or immediately after operation of that element.

Obtaining the Instrument

The mechanical portion of the instrument is being built in the workshop of the Chemistry Department of the Imperial College of Science and Technology, London S.W.7. under the direction of Dr. Ronald Mason, following specifications and drawings obtained from Dr. Henry Levy of the Chemistry Division, Oak Ridge National Laboratory. The x-ray tube and slit system have been obtained from the Philips Company. As usual in University shops, progress is slow though we hope the instrument will be running by Easter.

A specification of the counting, punching and control system was issued by us on 9 April 1962 and sent for tender in particular to the English Electric Company whose range of logical blocks seem to us particularly suitable to laboratory control systems. The English Electric Company did not tender but informally advised us that the supply of the completely engineered system would cost more than we had, though this was not further defined. The Company did, however, suggest that Dr. Fauling travel to the works and design the system with the help of their engineers. This in

fact occurred at the Kidsgrove Works of the English Electric Company during the week of 17 September 1962 when the logic of the system was completely designed. Subsequently Dr. Pauling produced complete engineering drawings of the system which are available for the construction and wiring. The assembling of the components, the construction of control panels and the back wiring of the system is being done by a technician of the Electrical Engineering Department of the Imperial College of Science and Technology starting 14 January 1963. The estimated time for the complete wiring of the system is 150 man hours. The components of the system have been ordered and have mostly been delivered. This project is a joint collaborative effort among Professor J.D. Bernal, Professor of Physics at Birkbeck College, Dr. Ronald Mason of the Chemistry Department, Imperial College of Science and Technology and Dr. Peter Pauling of University College, all in the University of London. Dr. Mason has received a grant from the Department of Scientific Research and Development to purchase the instrument and to support a post-doctoral fellow for three years. The costs of the instrument are:

Stabilized x-ray generator Philips PW 1010 including 2 x-ray tubes	£ 2800
---	--------

<u>Nucleonics:</u> Scintillation probe, amplifier, pulse height analyzer, stabilized high voltage supply, potentiometer, quench unit, 2 Geiger tubes, logarithmic ratemeter, pen recorder.	1200
---	------

<u>Control system:</u> Steelwork, counters, logic, tape punch, control panels	1900
--	------

1

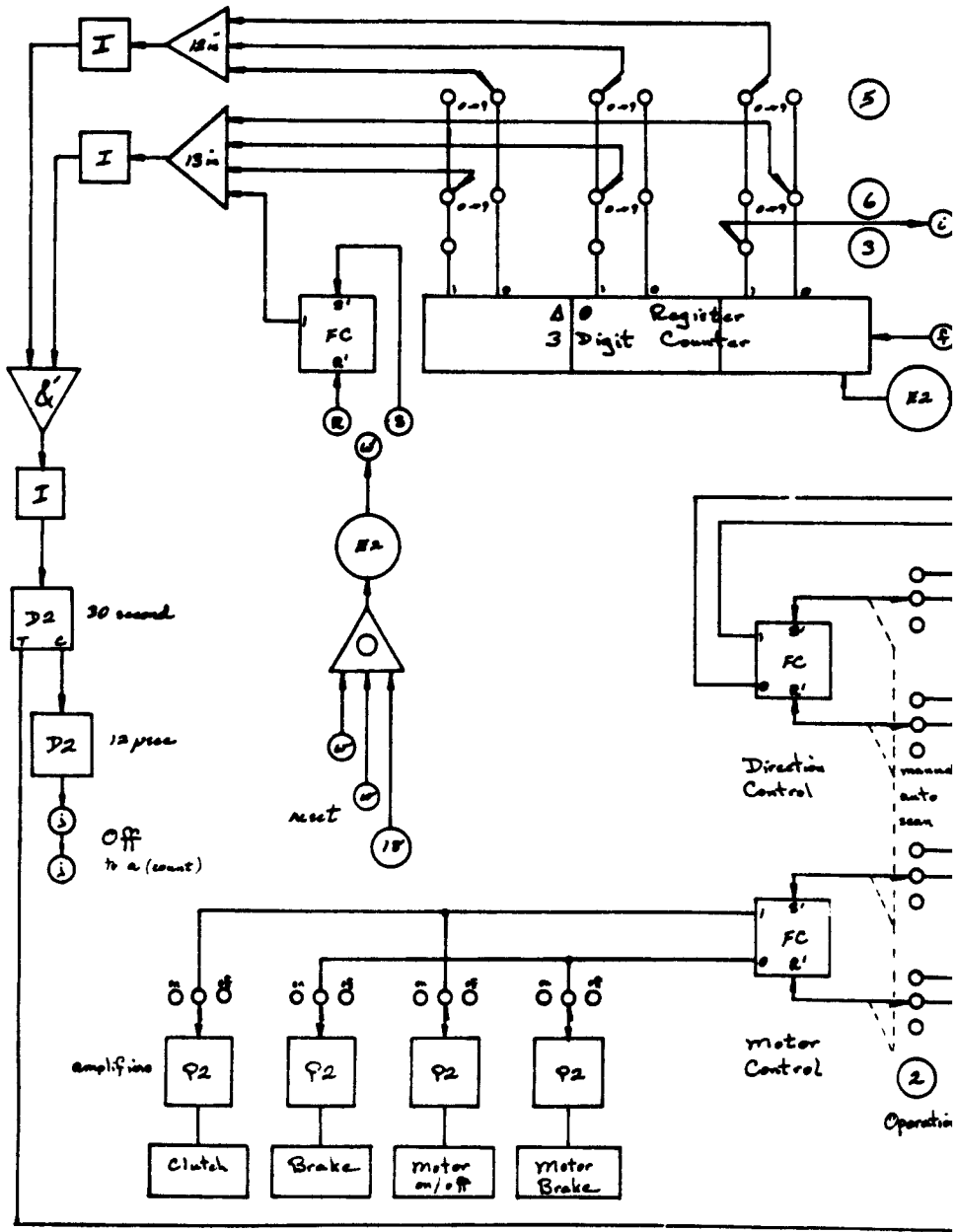

Peter Pauling University College London 15 December 1962

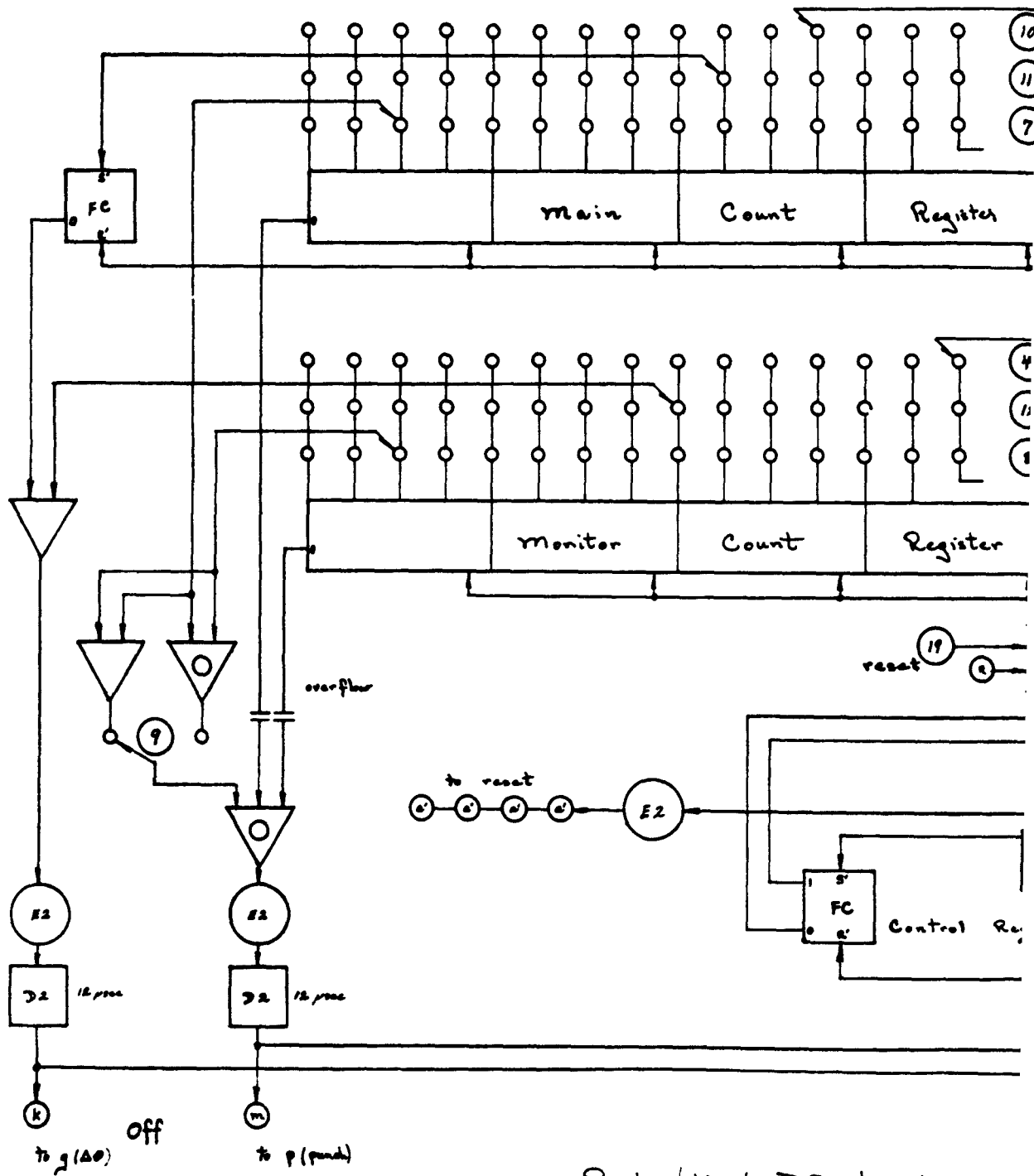

1

Powder / liquid Diffractometer
 Peter Pauling University College

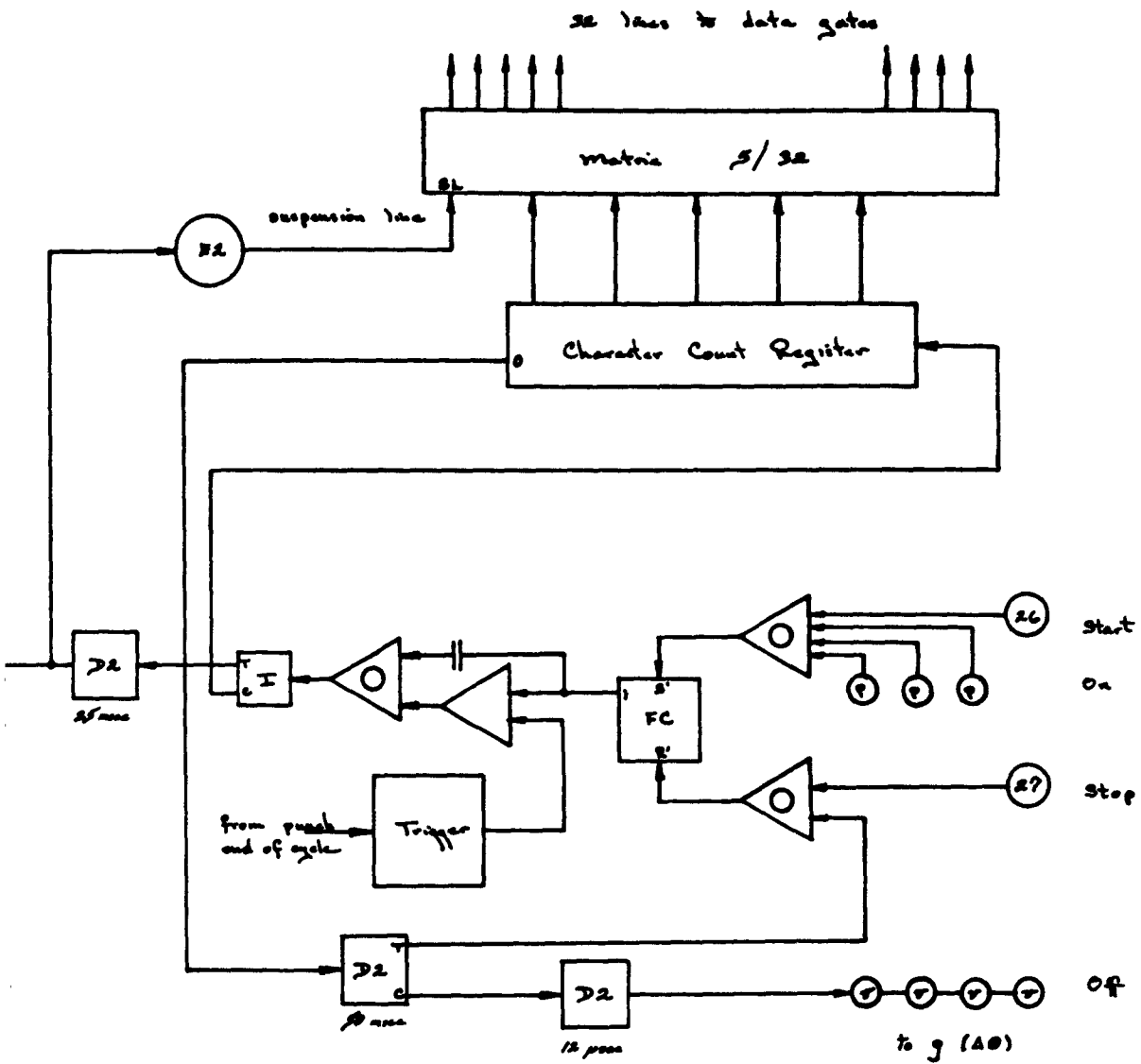

Powder / liquid Diffractometer

Punch Circuit Logic

drawing number 1027

Peter Pauling

University College London

9 December 1962



DC access to 0 and 1 states (true and complement) of each binary element

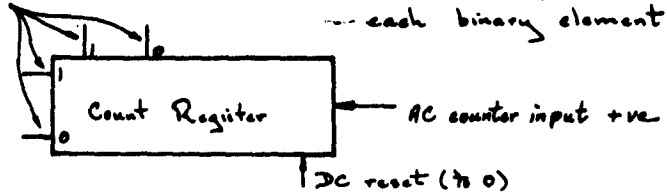

Binary coded decimal or binary counter

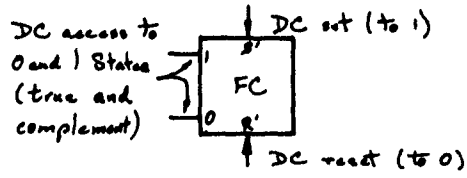

Binary storage element



Emitter follower

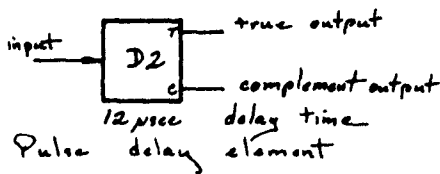

Pulse delay element

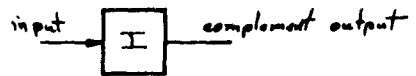

Inverter amplifier



Pulse differentiator

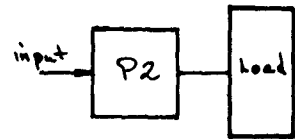

Transistor current amplifier

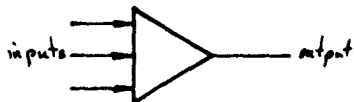

AND gate

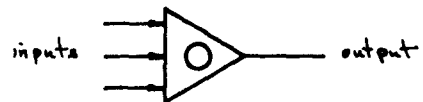

OR gate

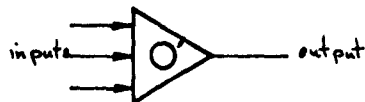

Or gate used as +ve AND gate

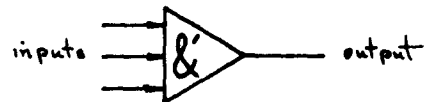

And gate used as +ve OR gate



Manual switch



fixed switch contact



movable switch contact

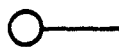

Plug jack connection

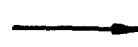

Pulse direction

Powder / liquid Diffractometer Drawing Conventions

Peter Pauling 7 January 1963

drawing number 1029

3. Structural Information Determined

Almost all the information on the structure of substances that we have obtained has been by means of single crystal diffraction techniques. This is partially to obtain exact structural information to compare with the results of our one dimensional studies, partially because a large number of problems in which a reasonable amount of single crystal analysis has been the most economic way of obtaining structural information have come up, and partially because our experimental facilities for easily obtaining the large amounts of high quality one dimensional diffraction data needed for this investigation have been limited. Our personnel resources have so far been better spent using single crystal techniques though this will change with the use of our new instrument. The major structural studies we have done are reported below, the state of the analysis and the information available at the present time being given for each study.

a) TiD₂Cl₄ and its isomorphs

The structure of the compound titanium bis *o*-phenylene bis-dimethylarsine tetrachloride (TiD₂Cl₄) was determined in 1961 and reported in FTR 1 1 November 1961 on the basis of 80 measured planes in the (100) and (110) zones. We have taken precession photographs being the (HK0) to (HK2), (HOL) to (H3L) and (H,H,L) to (H,H_±4,L) zones with MoK(alpha) radiation and these are being processed for a proper least squares refinement of the structure. The data processing is almost complete but the refinement is not yet started.

We have also carefully taken a new series of powder photographs of this compound and of the isostructural compounds of vanadium, zirconium and hafnium in order to test the sensitivity of our RDC methods on this relatively simple structural problem and to try to determine something about the variations in structure in the various compounds by pseudo three dimensional techniques using the indexed powder data.

Though not directly concerned with this report, another isostructural eight coordinate compound has been prepared by Mr. David Keppert of these laboratories. This is the analogous compound of niobium.

The structure of TiD_2Cl_4 as known at present is reported in FTR 1, 1 November 1961 (revised) under contract number DA-91-591-EUC-1633.

b) $Co (Ph_2CH_3AsO)_4 (ClO_4)_2 (NO_3)_2$ and $(ClO_4)(NO_3)$

In collaboration with Mr. Gordon Rodley of these laboratories who prepared the compounds and has done most of the work we have been studying the compounds cobalt tetradiphenylmethyldiarsineoxide diperchlorate, dinitrate and nitrate perchlorate. We have made a partial study of the nitrate and the nitrate-perchlorate to determine the unit cell size, symmetry and contents and are in the process of a complete study of the perchlorate.

The perchlorate and nitrate are isostructural, tetragonal, space group $P4/n$ $a = b = 16.33 \text{ \AA}$, $c = 10.77 \text{ \AA}$ (for the perchlorate), with two molecules per unit cell. The

mixed nitrate perchlorate has a superlattice twice as big along the unique axis as that of the perchlorate or nitrate and has spacegroup $F4_2/n$ with four molecules per unit cell.

We have calculated a sharpened Patterson function for the zones (001), (100) and (110) of the perchlorate from data collected out to the copper limit on precession and Weissenberg cameras. These have been partially interpreted in terms of the Co, As, O and Cl atoms.

A set of positions for the major atoms consistent with the crystal symmetry, the point symmetry of the various atomic groups and with the three available Patterson projections is: for the separate compounds $(ClO_4)_2$ and $(NO_3)_2$

space group number 85; $P4/n$

Co in 2 c 4 $0\frac{1}{2}z$ and $\frac{1}{2}0\bar{z}$ $z = \text{about } 0.21$

Cl or N

in 4 f 2 $00z$ $00\bar{z}$

$\frac{1}{2}\frac{1}{2}z$ $\frac{1}{2}\frac{1}{2}\bar{z}$

for the mixed compound $(ClO_4)(NO_3)$

spacegroup number 86; $F4_2/n$

Co in 4 c 2 $0\frac{1}{2}z$ $\frac{1}{2}0\bar{z}$

$0\frac{1}{2}\frac{1}{2}+z$ $\frac{1}{2}0\frac{1}{2}-z$

Cl and N

in 4 f 2

$\frac{1}{2}\frac{1}{2}\frac{1}{2}+z$ $\frac{1}{2}\frac{1}{2}\frac{1}{2}-z$

A structure of this sort, while consistent with the symmetry of the crystal, is not very satisfactory from the point of view

of either the ionic packing or of the expected coordination of the cobalt atom. Chains of similarly charged perchlorate or nitrate ions or both run parallel with the tetragonal axis through the crystal in the region of the phenyl rings. In addition we expect octahedral coordination of the cobalt atom which can only be obtained by the inclusion of water molecules in the crystal.

Several other possible arrangements of atoms in these crystals become possible by proposing free rotation of atomic groups so that, for example, the Cl atom of the perchlorate ion, which has point symmetry $\bar{4}$ and 2 might be placed in a crystallographic special position with symmetry 4. Using this premise a structure for the nitrate or perchlorate with the atoms cobalt and two sets of nitrogen or chlorine in positions $2\ c\ 4\ 0\frac{1}{2}z$ and $\frac{1}{2}0\bar{z}$ of space group $85\ P4/n$. Similarly the atoms cobalt, nitrogen and chlorine in the mixed nitrate perchlorate would be in $4\ e\ 2\ 0\frac{1}{2}z, \frac{1}{2}0\bar{z}, 0\frac{1}{2}z+z$ and $\frac{1}{2}0\frac{1}{2}-z$. The structure suggested satisfies the expected coordination of cobalt and general packing requirements. In the mixed compound, each cobalt would be coordinated to one perchlorate and one nitrate which is expected from infrared data.

At the present stage of the structure analysis, based on the three Patterson projections, we can say that the cobalt atom is coordinated to four oxygen atoms at the vertices of a square at a distance of 3.3 Å. The Co - O - As angle is

140°, the As - O distance being 1.7 Å.

In order to resolve the uncertainties in these structures we have collected a good deal of three dimensional data out to the copper limit for the perchlorate. The zones available are:

(HK0) to (HK3)

(HOL) to (H2L)

(HHL) to (H, H±2, L)

This data has been measured and corrected for Lorentz and polarization factors. It has now been scaled and we shall shortly calculate a three dimensional sharpened Patterson function with which we expect to be able to determine the structures.

c) Zr(acac)₃Cl and Zr(acac)₃Cl.H₂O

We have performed a preliminary investigation of the compounds Zr(acac)₃Cl and presumably Zr(acac)₃Cl.H₂O where acac is acetylacetonate, the former containing presumably 7 coordinated Zr^{IV} and the latter possibly 8 coordinated Zr^{IV}. The anhydrous compound is fairly unstable and must be protected from water. It is orthorhombic with cell parameters approximately a = 8.0 Å, b = 14.2 Å, c = 15.6 Å, $\rho_{\text{calc}} = 1.5$ if n = 4 molecules per unit cell. The space group is probably P2₁2₁2₁. A stable monoclinic material is presumably Zr(acac)₃Cl.H₂O which gives the same powder picture as Zr(acac)₃Cl which has been left open to the air for a while. Crystals of the hydrate have been studied and

and the data indexed in terms of a monoclinic unit cell with $a = 10 \text{ \AA}$, $b = 9.5 \text{ \AA}$, $c = 12.8 \text{ \AA}$, $\beta = 124^\circ$. New samples of the substances have been prepared by Dr. Michael Cox who prepared the original samples.

d) Bromine bisquinoline perchlorate

In order to test our techniques on organic compounds, we have spent a good deal of time attempting to analyse the structure or structures of the compound bromine bisquinoline perchlorate, BrQ_2ClO_4 , prepared by Dr. R.G. Tonkyn during his stay in this laboratory under the auspices of the National Science Foundation. The compound contains the Br^+ ion which is believed to be two-coordinate. Three crystal forms have been found and the results of the investigation to date are presented here.

Three samples of compound I were prepared; these have identical powder diffraction photographs. Single crystal photographs have been taken and they, and the powder pictures, can be indexed (with the aid of the One Dimensional computer programme) in terms of a B centred monoclinic unit cell of $a = 30.74 \text{ \AA}$, $b = 6.8 \text{ \AA}$, $c = 17.5 \text{ \AA}$, $\beta = 90^\circ$ with 8 molecules per unit cell. The data can be reindexed in terms of the primitive monoclinic unit cell of $a = 17.4 \text{ \AA}$, $b = 6.85 \text{ \AA}$, $c = 17.0 \text{ \AA}$, $\beta = 119^\circ$, spacegroup $\text{P}2_1/\text{c}$, 4 molecules per unit cell.

Two crystals from the second preparation of the compound have been studied. The data have been indexed in terms of

a triclinic unit cell with $a = 8.59$ A, $b = 8.34$, $c = 15.29$ A, $\alpha = 102^{\circ}49'$, $\beta = 98^{\circ}9'$, $\gamma = 114^{\circ}10'$ with $Z = 2$ molecules per unit cell if the density is approximately the same as that of compound 1.

The third form of crystal is fairly stable. It is monoclinic, $P2_1/c$, $a = 5.45$ A, $b = 21.6$ A, $c = 8.0$ A, $\beta = 99^{\circ}49'$ with two molecules per unit cell. This crystal cannot be quite straightforward: either there is free rotation of the perchlorate groups to make them spherically symmetrical or the crystal does not have in it what we have been told is in it. We have available a good deal of three dimensional data for this compound and hope to process it and determine the structure during the coming year.

We have done a good deal more with compound I. We have collected (HOL) to (H3L) and (HK0) to (HK4) data from precession and Weissenberg photographs giving a total of about 1200 independent planes. These have been scaled, corrected for Lorentz and polarization factors sharpened according to the function

$$(k + s^2) \exp (bs^2) \hat{f}^{-2}$$

(Jacobson and Lipscomb, Acta Cryst., 14 598 (1961)) with $k = 0.167$ and $b = -3$, and used to calculate the three dimensional sharpened Patterson function.

We have been held up somewhat in our work on this structure by discovering that some of our data was obtained

from a crystal that was twinned. The effect of this partially twinned data were visible in the Patterson function as first calculated. We have rephotographed and remeasured this data, corrected and rescaled it, and have now recalculated the sharpened Patterson function. The quinoline rings are clearly visible in this function (through the bromine ring interactions) though there is still some uncertainty about the anions.

Table 1

Coordinates of the bromine and quinoline ring atoms in the crystal of bromine bisquinolin perchlorate. (derived from the sharpened Patterson function.)

	x a	y b	z c
Br ₁	.125	0.25	.500
C ₁	.179	.25	.367
C ₂	.225	.25	.309
C ₃	.254	.25	.342
C ₄	.263	.25	.418
C ₅	.303	.25	.459
C ₆	.308	.25	.533
C ₇	.266	.25	.582
C ₈	.229	.25	.550
C ₉	.221	.25	.475
C ₁₀	.067	.25	.633
C ₁₁	.025	.25	.591
C ₁₂	-.004	.25	.658
C ₁₃	-.013	.25	.582
C ₁₄	-.053	.25	.541
C ₁₅	-.058	.25	.467
C ₁₆	-.016	.25	.418
C ₁₇	.021	.25	.450
C ₁₈	.029	.25	.525
N ₁	.183	.25	.433
N ₂	.071	.25	.567

spacegroup B2₁/c, a = 30.74 b = 6.81 c = 17.05

β = 90

e) Nickel dibromine 2,5 dimethylpyrizine

The analysis of the compound 2,5-dimethylpyrizine dichloro-nickel (II) being undertaken by Professor F.D. Ayres with our collaboration has been completed. Professor Ayres has been on sabbatical leave from the Department of Chemistry of Reed College, Portland, Oregon.

The crystals were prepared by Dr. Barry Lever of these laboratories. They are a deep purple colour, stable in air, but we were unable to obtain an untwinned crystal. The crystal from which the major part of the data was collected was in fact three crystals twinned through the c axis. The compound is monoclinic, spacegroup $C2/m$, $a = 9.088 \pm 0.01 \text{ \AA}$, $c = 6.520 \text{ \AA}$, $\beta = 108^\circ 36'$ two molecules per unit cell.

We have collected two dimensional data of the three major zones out to the copper limit with precession ($MoK\alpha$) and Weissenberg ($CuK\alpha$) cameras. This data has been corrected for Lorentz and polarization factors, and, for those planes in which the twins are superimposed, for the effects of twinning. The three sharpened Patterson functions were calculated from which all the atomic positions were clearly determined. The structure has been refined using the isotropic least squares programme written by J.S. Rollett for the Mercury computer. At present the three zones have been independently refined. The data falls off in a systematic way differently for the three zones, and while the refined coordinates for the separate zones are not significantly

different, the isotropic thermal parameters are different. We are correcting the separate data for these systematic effects and shall publish the structure with the three zones combined.

The R factors for the separate zones using the coordinates given in Table 2 are HKO 9.4% and HOL 7.5%.

In the structure the nickel atoms are at the origin, the bromine atoms being above and below along the b axis at a distance of 2.30 ± 0.01 Å and the pyrazine molecules lie in the ac plane connecting the nickel atoms along the c axis. The nickel nitrogen distance is 1.88 ± 0.06 Å.

Table 2

Parameters for $\text{NiBr}_2((\text{CH}_2)_2 \text{N}_2\text{C}_4\text{H}_2)$

Atom	x	y	z	B
Ni ₁	0	0	0	2.85
Br ₁	0	.28182	0	2.77
N ₁	-.00492	0	.28707	3.0
C ₁	.13459	0	.45421	1.68
C ₂	-.13339	0	.33192	1.65
C ₃	.29219	0	.41182	3.41

spacegroup C2/m $a = 9.09$ Å, $b = 8.20$ Å

$c = 6.52$ Å, $\beta = 108^\circ 36'$ $Z = 2$ mols/cell.

f) K Pt (acac)₂ Cl

The crystal structure of the compound potassium platinum bisacetylacetonate chloride (KPt(acac)₂Cl) has been completely determined and refined by single crystal methods. The compound was prepared by Dr. Ron Long of these laboratories and the structure determined by Dr. Ronald Mason, Dr. Peter

Fauling and Mr. G.B. Robertson.

Potassium bisacetylacetonate chloro platinum (II) crystallizes from aqueous solution as monoclinic crystals, space group $I2/c$, $a = 25.97$, $b = 13.73$ Å, $c = 7.81$ Å, $\beta = 92.0^\circ$ eight molecules per unit cell.

X-ray diffraction data from precession and Weissenberg photographs using $CuK(\alpha)$ and $MoK(\alpha)$ radiation, including the HK0 to HK3, HOL to H4L and OKL to 3K1 zones have been measured, corrected for Lorentz and polarisation factors and put on a common scale. This includes about 2500 independent observed planes. We have calculated the three dimensional sharpened Patterson function and determined from it the position of the platinum atom, the chlorine atom, potassium atoms and gained some information about the location of the acetylacetonate rings. By inspection of the observed Fourier synthesis and particularly the difference synthesis based on the platinum atom alone we were able to place all the atoms of the structure with a high degree of certainty. Atomic coordinates and anisotropic temperature parameters have been refined by eight rounds of least squares calculation. The R factor $\frac{\sum \Delta F}{\sum F_0}$ is 0.064 and ΔF^2 is 0.60×10^9 at the present stage with the structural parameters listed in Table 3. This compares with $R = 0.10$ and $\Delta F^2 = 1.8 \times 10^9$ at the end of round 2 reported in QTSR 3, 1 September 1962.

Table 3

Coordinates of atoms in the crystal of
the compound $K Pt(acac)_2Cl$

Atom	X	Y	Z
PT ₁	.39386	.32866	.54635
CL ₁	.47751	.31610	.47137
O ₁	.32229	.33931	.62015
O ₂	.40693	.47784	.54685
C ₁	.29901	.41729	.64864
C ₂	.31986	.51351	.62625
C ₃	.36844	.54021	.57847
C ₄	.24494	.40663	.71768
C ₅	.37949	.64318	.55183
O ₃	.45338	.07462	.56256
O ₄	.39778	.13149	.25403
C ₆	.42180	.12356	.63439
C ₇	.37810	.17745	.54120
C ₈	.36653	.15972	.34965
C ₉	.42310	.12963	.83050
C ₁₀	.30978	.17765	.30124
K ₁	.5	.09089	.25
K ₂	.5	.51231	.25

The coordination polyhedron of the platinum II atom is square planar with four ligands at the vertices of a square one chlorine, two oxygens of one the acetyl acetone groups and surprisingly a γ -carbon atom of the other acetylacetone group. A drawing (prepared with our programme for calculating drawings) of the complex ion $(Pt(acac)_2Cl)^-$ is shown in Figure 1 with interatomic distances and certain angles. The estimated standard deviations for these distances are 0.015Å for

the Pt - Cl distance, 0.025A for the Pt - O and Pt - C distances and 0.10A for all the C - C and C - O distances.

The potassium atoms, of which there are two crystallographically independent types, are not shown. Each is surrounded by a distorted octahedron of other atoms; K₁ by three pairs of oxygen atoms at 2.73, 2.76 and 2.89 A and K₂ by a pair of oxygen atoms at 2.84 A and two pairs of chlorine atoms at 3.22 and 3.25 A. The chlorine atom is surrounded by three pairs of potassium atoms at 3.22, 3.25 and 3.61 A.

A paper entitled "The structure of a carbon bonded acetylacetonate complex of platinum(II)" by B.N. Figgis, J. Lewis, R.F. Long, R. Mason, R.S. Nyholm, P.J. Pauling and G.B. Robertson has been published in Nature (195 1278) giving these results and discussing the nuclear magnetic resonance and infra-red properties of this substance. A paper describing this work completely by R. Mason, Peter Pauling and G.B. Robertson is in preparation.

This four coordinated platinum structure is different to the five coordinated structure postulated by us last year (and reported by Dr. Pauling at the Annual Meeting of the American Crystallographic Association, Boulder Colorado, August 2 1961) on the basis of the two dimensional diffraction data available then, and we withdraw that structure. The original incorrect proposal is not wasted, however, because we can calculate the expected intensity and radial distribution curves for the two structures and compare them with

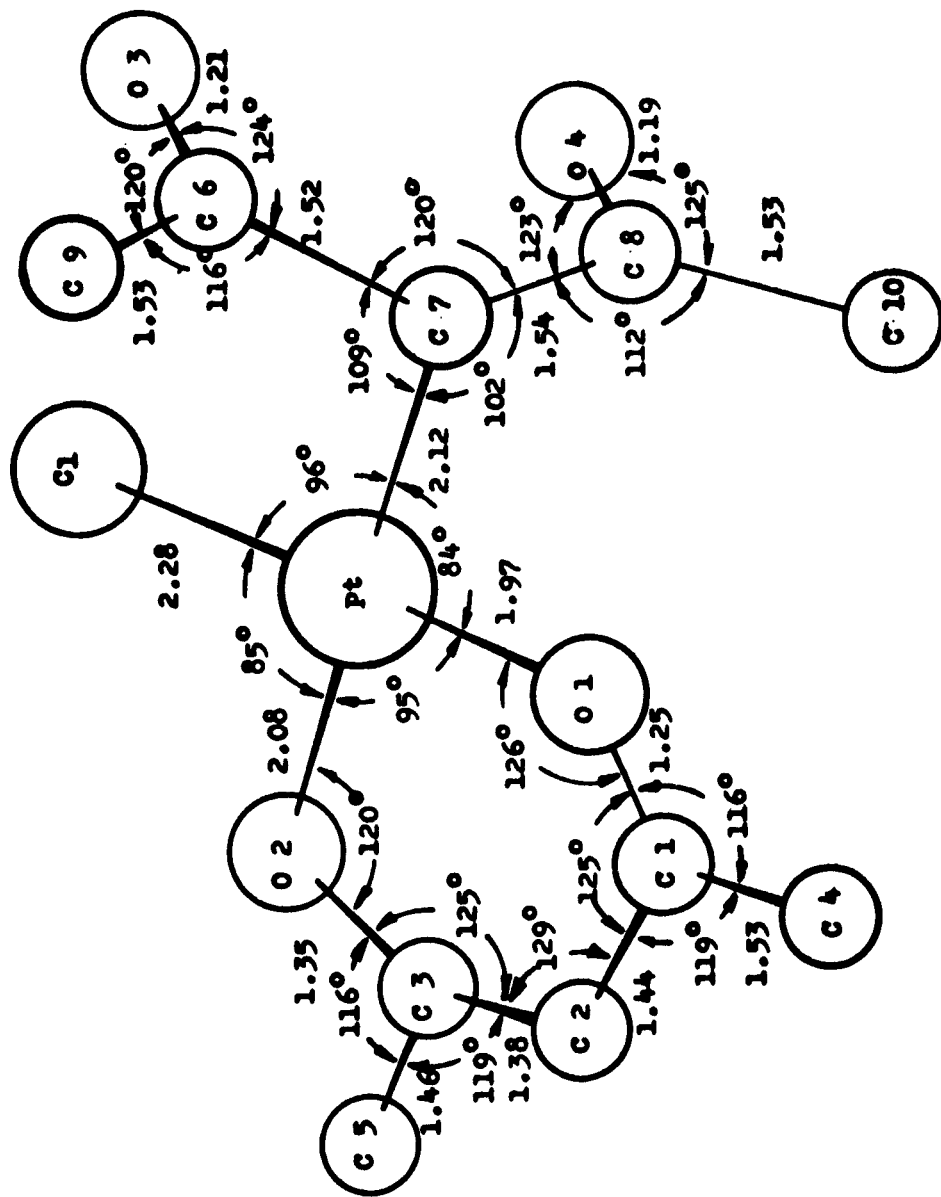

Figure 1: A diagram showing the structure of the complex ion $(Pt(acac)_2Cl)^-$ in the compound $KPt(acac)_2Cl$ giving interatomic distances and angles. Parameters as input to SFLS round 9.

the observed intensity and radial distribution curves for the compound and see whether this technique is sensitive to the different structures.

g) KPt(acac)₂

We have performed a preliminary investigation of the crystal structure of the compound KPt(acac)₂, where acac = acetyl-acetone prepared by Dr. R. Long of these laboratories. The data has been indexed in terms of a C centred triclinic unit cell with $a = 8.7 \text{ \AA}$, $b = 13.7 \text{ \AA}$, $c = 14 \text{ \AA}$, $\alpha = 108^\circ$, $\beta = 89^\circ$, $\gamma = 87^\circ$, 4 molecules per unit cell, spacegroup F1 or $\bar{P}1$, in which the latter is perhaps more probable.

We are rather interested in the structure of this compound in relation to the structure of KPt(acac)₂Cl just reported because of the nuclear magnetic resonance spectrum of the two compounds. The H¹ nuclear magnetic resonance spectrum of KPt(acac)₂Cl at 40 Mc/s shows the presence of two separate methyl absorptions of equal intensity, with chemical shifts of 1.94 and 1.46 p.p.m. relative to dioxane. The splitting of the methyl protons by coupling to the platinum (platinum-195, abundance 33.7 per cent, spin ½) was readily observable for one of the groups ($J_{\text{Pt-H}} = 5.6 \text{ c.p.s.}$) but not for the other ($J_{\text{Pt-H}} = 2.5 \text{ c.p.s.}$). On the basis of the structure shown in Fig. 1, three groups of methyl resonance frequencies might have been anticipated since there seems no a priori reason for equivalence of the methyl groups of the oxygen-coordinated acetylacetone. The chemical shift

between them is not expected to be large, however, and the fact that they give rise to but one group in the nuclear magnetic resonance spectrum must be due to a chemical shift below the limit of resolution. The signals from the γ -carbon-protons were not of sufficient intensity to be interpreted.

The nuclear magnetic resonance spectrum of the compound $\text{KPt}(\text{acac})_3$, shows the presence of two groups of methyl protons of intensity ratio 2:1 and with Pt - H coupling constants of 6.7 and 2 c.p.s. respectively. This may be taken to indicate that the stereochemistry of the complex is square planar with one 'normal' oxygen coordinated - and two γ -carbon coordinated - acetylacetonate residues or, possibly, is five coordinate with two oxygen coordinated and one carbon coordinated ligand.

We plan to study this compound a little more. We have available diffraction photographs with the (HKO), (HKL) and (HOL) data and are currently taking the (OKL), (1KL), (2KL) and (3KL) data with $\text{MoK}(\alpha)$ radiation on the integrating Weissenberg camera.

h) $\text{Cr}_3(\text{ac})_6(\text{OH})_2\text{Cl}\cdot 7\text{H}_2\text{O}$

In collaboration with Dr. B.N. Figgis of these laboratories who has done most of the work, we have been working on the structure of the compound $\text{Cr}_3(\text{ac})_6(\text{OH})_2\text{Cl}\cdot 7\text{H}_2\text{O}$ where ac is acetate CH_3COO . Crystals are orthorhombic, spacegroup $F2_12_12$ with four formula units per unit cell. $a = 13.69 \text{ \AA}$

$b = 23.22$ $c = 9.17$. We have collected three dimensional data to the copper limit on precession and Weissenberg cameras being the (HK0) to (HK3), (OKL) to (3KL) and (H,K,H) to (H,K,H \pm 3), about 1800 independent observed planes. This data has been corrected for Lorentz and polarization factors, placed on a common scale, sharpened by the Jacobson and Lipscomb technique, and the three dimensional sharpened Patterson function calculated. The function seems to be interpretable in terms of the Cr atoms and possibly the Cl but has not yet been completely interpreted.

j) Ni(Ph₃FO)₄ (ClO₄)₂

In collaboration with Dr. B.N. Figgis of these laboratories we have performed a preliminary investigation of the compound Nickel tetratriphenylphosphineoxide diperchlorate (Ni(Ph₃FO)₄ (ClO₄)₂). The details of the crystal structure known at present are: Laue symmetry 4/m, body centred 6 molecules per unit cell, $a = b = 13.6$ A, $c = 52$ A, possible spacegroups I4 (79), I $\bar{4}$ (82) or I4/m (87). The faces of the crystals of the probably isostructural compound Co(Ph₃AsO)₄ (ClO₄)₂ prepared and studied by Mr. Gordon Rodley conform to the crystal class 4/m suggesting space-group I4/m.

That there be six molecules in a body centred tetragonal unit cell is very unusual; it implies that the metal atoms are necessarily in special positions and furthermore that there be at least two types of metal atom crystallographic-

ally not equivalent.

The planes of diffraction data perpendicular to the unique axis show very strong pseudo thirding, (HKL) is strong only for $L = 3n$ to $L = 27$ (the camera limit). This implies the structure closely but not exactly fits in a body-centred tetragonal unit cell of $c = 17 \text{ \AA}$ with 2 molecules per unit cell. It also probably excludes the possibility of the space group being $I4$ which would require the Ni atoms to be in locations:

2 Ni in 2 a 4 at $00z$ (probably excluded)
 4 Ni in 4 b 2 at $0\frac{1}{2}z, \frac{1}{2}0z$

We have corrected the limited data available at present, the HKO and HOL zones (Cu radiation with precession camera) for Lorentz and polarization factors, sharpened as above, and calculated the sharpened Patterson functions. Study of the HKO sharpened Patterson has suggested Ni, O and P positions and of the HOL sharpened Patterson Ni, P and Cl positions. These positions are such that one Cl atom (of a perchlorate group) is 5 \AA from the Ni atom along the tetragonal axis.

This structure is really too big to try to tackle with two dimensional methods. The large amount of symmetry of the structure encouraged us to proceed. The structure is very similar to that of the compound $\text{Co}(\text{Ph}_2\text{CH}_2\text{AsO})_4(\text{ClO}_4)_2$. The packing is somewhat different and the perchlorate groups are arranged differently but the main coordination of the

FTR 1, 1 December 1962. 40.

metal atoms by the oxides is the same.

We would like to collect a little more diffraction data for this compound but have been unable to obtain another crystal. We shall try to re-interpret the data we have available in the light of the structure of the related cobalt arsine oxides mentioned when they are available.

4. A proposal for the use of ATLAS for crystallographic computing

The University of London is to obtain a Ferranti ATLAS digital computer in the spring of 1964. We wish to propose a system of programme organisation for the efficient use of this machine. The proposals are derived from the point of view of the work required to flexibly process data rather than from the point of view of a few major programmes.

The ATLAS computer is a large fast shared programme machine. The University of London machine in the first instance is to have a 2 microsecond cycle time core store of 16000 words, drum store of 100000 words, 10 magnetic tape units, a combined hardware and software supervisory control system to allow the simultaneous operation of several programmes and an average operation time of 2 microsecond.

In October 1962 we issued the following memorandum.

In order that there be the maximum flexibility of operation, greatest simplicity in use, and most structure analysis per unit effort on the part of the crystallographer, we wish to agree some conventions for the use of the ATLAS with our colleagues:

In order of importance, the conventions are:

1. The storing of crystallographic data on magnetic tape.
2. The levels of programming.
3. The storing of crystallographic constants and parameters.

We suggest the following:

1. STORING OF DATA

a) Data can be stored in lists on magnetic tape, each list with header and tailer, each plane using two 48-bit words laid out as:

1st word	h	h	l	a	b	c	d	
	12	12	12	3	3	3	3	bits
2nd word	F _{obs}			Standard Deviation				
	36			12 (L.S.) bits				

Where a b c d are four octal digits to be used as list markers.

b) That the header contain

Problem title a b c d
wavelength for list
scalefactor

c) That the tailer indicate whether the list is continued elsewhere on magnetic tape or terminates here.

d) That certain list processing routines be available to work on these lists.

2. THE LEVELS OF PROGRAMMING

a) That there be four levels of programmes:

- i) ~~subroutines~~
- ii) Programmes a) Permanent
 b) User written
- iii) Master Programme
- iv) Steering Tape.

b) ~~That~~

- i) Subroutines
- ii) Permanent programmes
- iii) As many as possible crystal constants
- iv) The Master Programme

be available on a reel of magnetic tape called the 'Crystal Compiler' .

c) ~~That~~ the 'Crystal Compiler' can work in conjunction with an Autocode compiler.

d) ~~That~~ the Master Programme read the steering tape and

- i) Transfer data to magnetic tape
- ii) Transfer data to fast store
- iii) Enter programmes
- iv) Compile user's programmes (using Autocode as a subroutine)
- v) List Process Data

e) That the Steering Tape will be the user's paper tape, it will contain

- a) Function names which refer to permanent programmes and subroutines.
- b) Directives which are instructions to store data, direct control, list process change data, output on line printer etc.
- c) Numbers, words or equations which give information required by directives.
- d) autocode statements of user's programme.

3. STORING OF CONSTANTS

a) That the locations and labels of as many as possible crystal parameters be agreed in 1024 (or more) long words, the positions fixed in the fast store (within the flexibility of address of ATLAS). 1024 words being two blocks of magnetic tape referred to by block number.

b) That these 1024 words contain

i) All constants

ii) Equivalent positions

iii) Magnetic tape block numbers of data lists

iv) Magnetic tape and fast store addresses of atom parameters

v) The same for f tables (if crystal compiler not used)

vi) as many other things as we can think of

c) That we agree on a form for storing f tables, atomic parameters, for example

$x, y, z, 6 \times b_{i,j}$, atom fraction

with atom type letter pair in L.S. 12 bits. This requires 10 long words per atom.

4. MODE OF OPERATION

i) Put Crystal Compiler into computer

ii) Put on Problem Magnetic Tape

iii) Put on Steering Tape

iv) Enter Master Programme

The Master Programme reads the Steering Tape and compiles and enters the programme accordingly.

a) New Problem. First Run

- i) The Problem Magnetic Tape will be blank
- ii) The Steering Tape will be headed with 'Problem Title'.
- iii) At the end of reading the Steering Tape, the data and constants are output on the Problem Magnetic Tape.

b) Any Subsequent Run

- i) The Problem Magnetic Tape is read in
- ii) The Steering Tape will be headed with 'Problem'

c) Output

Results will be put into agreed locations in the fast store or output on magnetic tape in lists with references in the fast store.

The data may also be output on a line printer.

5. PROGRAMMES AND SUBROUTINES ON CRYSTAL TAPE

Programmes

a) Data Processing:

- i) LP for Weissenberg, Precession, Diffractometer, Powder
- ii) Absorption
- iii) Scale on layers
- iv) Sort into order - dictionary or parity

- v) Look for discrepancies
- vi) Average equivalent reflections
- vii) Sharpen
- b) Structure Factors
- c) Least Squares
- d) Fourier. Slant Fourier. With output for contours or coordinates of peaks.
- e) Pattersons. Super position. With same output as Fourier.
- f) Distance angle.
- g) Plane through atoms.
- h) Statistics
 - i) Wilson plot.
 - ii) Ramachandran
- i) Sign Determination
 - i) Jayre's Equation
 - ii) Hauptman and Karle's methods
- j) Solution of phase triangle for isomorphous replacement.

Subroutines

- a) Inversion of a pos. def. matrix
- b) Transformation from natural to orthogonal axes
- c) Symmetry operations
- d) Transform from b_{ij} B_{KL}
- e) Interpolation in 3D (27 point)
- f) Interpolation for f-tables
- g) Quick sin cos exp functions
- h) Latent root and vector finder
- i) Principal axes and planes
- j) Distance calculations

It must be simple to add new functions to the crystal compiler and new directives to the master tape.

FTR 1, 1 December 1962. 47.

The concepts described in this memorandum have been further developed and a more detailed document is in preparation.

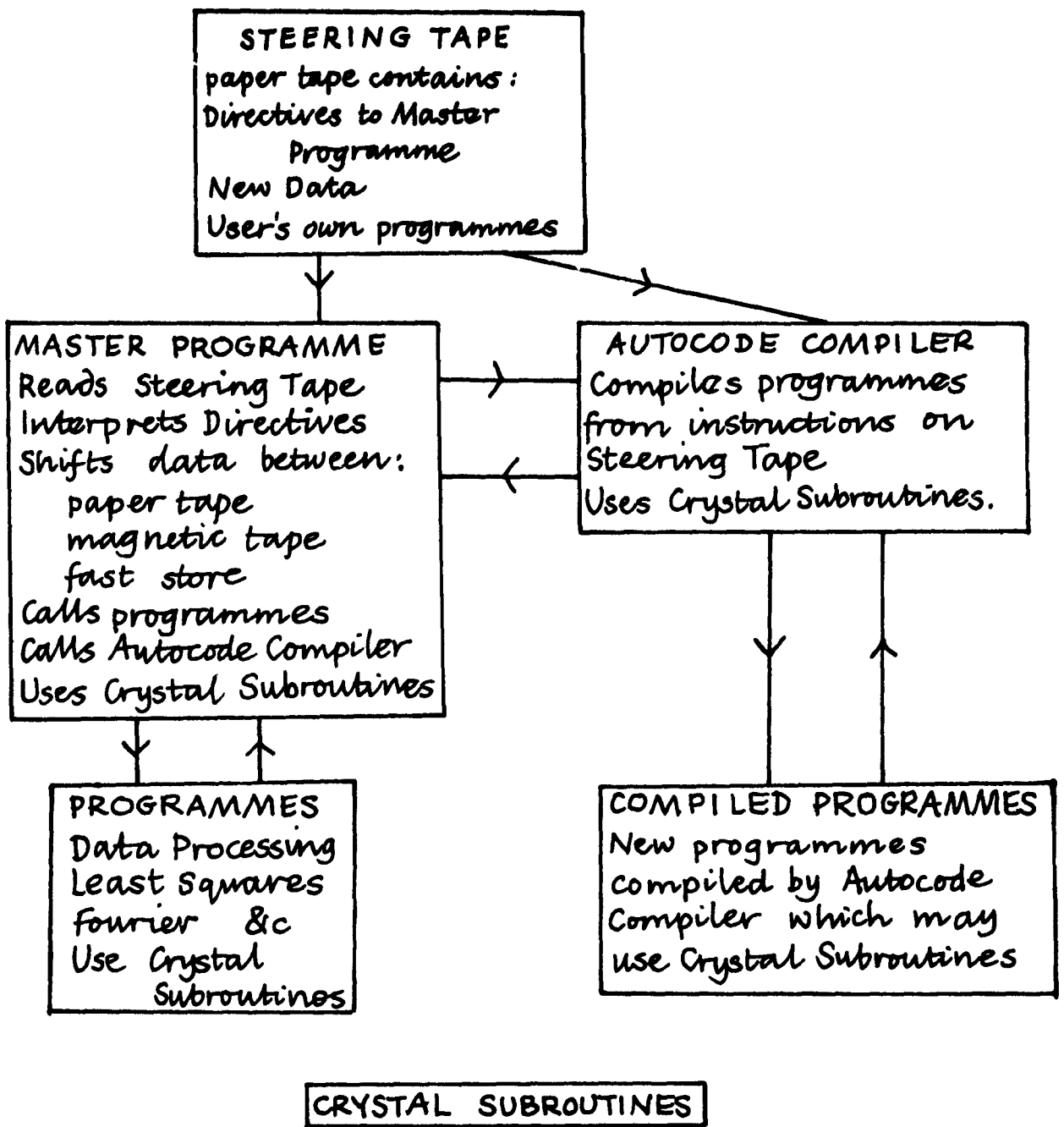

Proposed Levels of Programming for Atlas.

5. Plans for future work

We are putting our major effort at present into completing the several single crystal structure determinations we have under way, solving the structures, refining the structural parameters by least squares methods and shall publish these results. The definite information determined as a result of these single crystal investigations will be used in the interpretation of our one dimensional studies.

When our new automatic digital diffraction data collecting instrument is available (about Easter), we shall begin structural work by means of one-dimensional diffraction techniques in earnest. We shall collect data, operate on it, compare and correlate the observed curves with each other and with calculated functions as described in this report.

We are developing our ideas on the use of computers and plan to keep up pressure to get them adopted by the University of London group in order to increase the efficiency and power of the individual investigator in using these machines.

6. Administration including expenses

These investigations have been directed by Professor R.S. Nyholm and Dr. Peter Pauling; the crystallographic work has been done by Mr. G.B. Robertson who has worked full time on the projects and by the several people mentioned in this report; the computer programming and development of ideas for the use of ATLAS has been done by Mrs. Jean Dollimore who has devoted about three-quarters of her time to this project.

The purchase of the data collecting instrument has been supported by the Department of Scientific and Industrial Research in a grant to Dr. Ronald Mason of the Imperial College of Science and Technology. No major items of equipment have been purchased with funds connected with this contract.

The expenses of the year have been as follows:

Expenses for year 1 November 1961 to 31 October 1962

G.B. Robertson at 950 p.a.	£ 950. 0.0.
Superannuation	95. 0.0.
National Insurance	35.11.4.
Jean Dollimore at 550 p.a.	550. 0.0.
Group Pension	22.10.7.
National Insurance	16. 0.0.
Administration	120. 0.0.
Materials, consumables, etc.	224. 0.0.
Computing	<u>165. 3.8.</u>
	£ 2178. 5.7.