

UNCLASSIFIED

AD 409 455L

DEFENSE DOCUMENTATION CENTER

FOR

SCIENTIFIC AND TECHNICAL INFORMATION

CAMERON STATION, ALEXANDRIA, VIRGINIA



UNCLASSIFIED

NOTICE: When government or other drawings, specifications or other data are used for any purpose other than in connection with a definitely related government procurement operation, the U. S. Government thereby incurs no responsibility, nor any obligation whatsoever; and the fact that the Government may have formulated, furnished, or in any way supplied the said drawings, specifications, or other data is not to be regarded by implication or otherwise as in any manner licensing the holder or any other person or corporation, or conveying any rights or permission to manufacture, use or sell any patented invention that may in any way be related thereto.

CATALOGED BY DDC

AS AD No. 409455



BOOZ · ALLEN APPLIED RESEARCH, INC.

409 455L

DDC
RECEIVED
JUL 17 1962
L. B. ...
751A A

NO.OTS

COOPERATING AGENCY METHOD FOR
EVENT REPORTING AND ANALYSIS
(CAMERA)

M. P. deRegt

May, 1963

Report No. 180-2-48

A Report Prepared for the
Department of the Navy
Bureau of Ships
Contract NObsr 85241



BOOZ • ALLEN APPLIED RESEARCH, INC.

CHICAGO
WASHINGTON

For use of U.S. government agencies only.

Qualified requesters may obtain copies of
this report from Defense Documentation Center.

ABSTRACT

Certain large, national-level programs are characterized by participation on a nearly equal basis of several major services and agencies, tied together by a management group whose functions are of a coordinating rather than a directing nature. All aspects of such programs cannot always be determined initially, but may develop or evolve.

The Cooperating Agency Method for Event Reporting and Analysis (CAMERA) was developed as a program control technique for the U. S. Navy Management Staff, Bureau of Ships, Communications Satellite Program. Its purpose is to monitor all phases of a program in an expeditious and inexpensive manner.

Each participant in a program is required to report on the status of his tasks. For the CAMERA Report, all milestones are divided into various status categories: Completed, Cancelled, Rescheduled, New, Behind Schedule, Due Next Report Period, and Active. There are further break-downs within these categories to give a more detailed picture of each milestone--action taken, responsible agency, performing contractor, and appropriate dates.

The report is then distributed to all participants, who are able to see the over-all progress of the project. This is particularly valuable to each program manager in his decision-making activities.

The applicability of CAMERA to a multi-participant project was successfully demonstrated when the Navy COMSAT Management Staff used it during the conversion of the USNS Kingsport, a satellite communication ship. It is in this type of complex national inter-agency, and inter-service project that CAMERA proves a valuable management aid, including its use as a PRE-PERT data gathering tool.

This report describes the method in detail, including necessary information elements, the implementation of CAMERA, the report preparation procedure, and a description of a semi-automated procedure using an IBM 1401.

T A B L E O F C O N T E N T S

| | <u>Page</u> |
|---|-------------|
| ABSTRACT | ii |
| LIST OF ILLUSTRATIONS | vi |
| FOREWORD | 1 |
| I. INTRODUCTION | 2 |
| Navy Participation in the Communications Satellite Program | 2 |
| Project Management | 3 |
| Project Status Reporting and Analysis Techniques | 6 |
| The CAMERA Approach | 7 |
| II. BASIC CAMERA CHARACTERISTICS | 10 |
| Authority Required | 10 |
| Self-Generation | 11 |
| Self-Correction | 11 |
| Self-Organization | 12 |
| Ease and Speed of Report Preparation | 13 |
| Flexibility | 13 |
| III. THE CAMERA INFORMATION ELEMENTS | 14 |
| The Milestone Unit Record | 14 |
| Status Information | 17 |
| Milestone Status Analysis and Report Format | 18 |
| Special Reports and Reference Listings | 25 |

| | <u>Page</u> |
|--------------------------------------|-------------|
| IV. APPLICATION OF CAMERA PROCEDURES | 28 |
| General | 28 |
| Initial or Definition Phase | 28 |
| Build-Up and Correction Phase | 30 |
| Sustained Operations | 30 |
| Terminal Phase | 31 |
| V. REPORT PREPARATION | 32 |
| General | 32 |
| UPDAT Program Description | 44 |
| REPRT Program Description | 51 |

LIST OF ILLUSTRATIONS

| <u>Figure</u> | | <u>Page</u> |
|---------------|--|-------------|
| 1 | Projects ADVENT/SYNCOM Management As Affecting Navy Participation | 4 |
| 2 | Sample Page - Cancelled Milestones | 20 |
| 3 | Sample Page - New Milestones | 21 |
| 4 | Sample Page - Completed Milestones | 22 |
| 5 | Sample Page - Milestones Behind Schedule | 23 |
| 6 | Sample Page - Rescheduled Milestones | 24 |
| 7 | Sample Page - Milestones Due Next Report Period | 26 |
| 8 | Sample Page - Active Milestones by Subsystem | 27 |
| 9 | CAMERA Milestone Keypunch Sheet | 29 |
| 10 | Milestone Unit Record Card | 34 |
| 11a | TITLE Cards Listing | 36 |
| 11b | STATUS Heading Cards Listing | 36 |
| 11c | SUBSYS Heading Cards Listing | 36 |
| 11d | ABBR Cards Listing | 36 |
| 11e | END Card Listing | 36 |
| 11f | DATE Card Listing | 36 |

| <u>Figure</u> | | <u>Page</u> |
|---------------|--|-------------|
| 12 | Milestone Card With Status Information | 41 |
| 13 | UPDAT Source Program Listing | 45 |
| 14 | REPRT Source Program Listing | 52 |
| 15 | Flow Chart | 60 |

FOREWORD

The CAMERA approach described in this paper was developed as a program control tool for the Navy Management Staff, Bureau of Ships, Communications Satellite Program. Its use contributed toward successful completion of the Navy's mission to build a satellite communications ship. The ship was completed near the original schedule in a program beset by many difficulties, including a major schedule slide, a reversal to the approximate original schedule in order to support a NASA project, and the design changes necessitated by that added requirement.

CAMERA was developed over a period of only three or four months from a manually-maintained set of milestone charts, through a punched card operation, to the semi-automated procedure described in this report. Neither time nor money was available for development of a sophisticated computer program. Card formats and other characteristics still reveal the earlier phases through which the procedure passed.

The basic requirements for CAMERA were established by this management staff, and consisted of analysis of status information into categories of Milestones Completed, Milestones Behind Schedule, and Milestones Due Next Report Period. Details of the automated procedures were worked out in a series of discussions between this staff and Booz-Allen Applied Research, Inc., early in 1962. The first machine-generated report was distributed 1 April 1962, and covered the report period from 21 February to 20 March 1962.

CAMERA not only permitted this staff to maintain status information at a nominal cost, but also allowed a much more extensive monitoring of contractor and agency task status than could have been accomplished by use of manual methods.

Although a number of features of CAMERA were developed with eventual construction of a PERT network in mind, the necessity for PERT never materialized. The CAMERA reports were found to be adequate, considering the relatively modest scale of the Navy mission.

S. N. Ross, CDR, USN
Navy Management Staff
Communications Satellite Program

I. INTRODUCTION

I. INTRODUCTION

Navy Participation in the Communications Satellite Program

ADVENT was a Department of Defense research and development effort in active communications satellites. Its purpose was to demonstrate the feasibility of using real-time relay through active satellites in a 24-hour, equatorial, synchronous orbit for long distance, reliable military communications. Early in 1962, the Department of Defense announced a technical redirection and a reassignment of responsibilities for the Communications Satellite Program. The ADVENT program was reoriented to bring it into consonance with available boosters.

Over-all systems management of ADVENT had been the responsibility of the Department of the Army since September 1960, when it was transferred from the Advanced Research Projects Agency. Under Army management, a Project ADVENT Management Agency was established by the Army Signal Corps. The function of this agency was to provide over-all management and technical direction through development, installation, and total system evaluation phases.

Responsibilities were assigned to three military services: the Air Force for launching operations for ADVENT, the U. S. Army Signal Research and Development Laboratory, Fort Monmouth, New Jersey, for providing the ground environment, and the Bureau of Ships for providing the seaborne environment.

Subsequently, arrangements were completed between the Department of Defense and the National Aeronautics and Space Administration for the ADVENT ground system, including the ship station, to support Project SYNCOM. This project is also a synchronous communications satellite, but of a more modest nature than ADVENT. The ship, capable of communicating via SYNCOM as well as ADVENT, also has tracking, telemetry, and command capabilities for both satellites.

An outstanding characteristic of the ADVENT/SYNCOM Project was the participation on a nearly equal basis of several major services

or agencies, tied together by a management office whose functions, in view of the severe constraints, were of a coordinating rather than a directing nature. Figure 1 shows the organization of this project. For this reason, the approach developed by the Bureau of Ships and described in this report, is called "Cooperating Agency Method for Event Reporting and Analysis"--CAMERA.

Project Management

World War II marked the beginning of a quiet revolution in industrial organization and management. Technical development projects brought together many groups which found themselves with a common objective.

Prior to the war, these groups confined their activities to strictly functional lines in organizations divided into these same functional areas. Since that time, development projects have increased in number, complexity, scope, cost, and direction. In 1963, there are many projects running in the hundreds and thousands of millions of dollars, and requiring years or decades for completion.

The result of this quiet revolution is increasing emphasis on an organizational entity variously called Systems, Project, or Program Management, headed by a Project or Program Manager. The manager draws upon necessary specialties to staff his group, and tailors the project organization to suit the objective. Since there are generally distinct phases, such as research, design, prototype fabrication, etc., the project organization and its make-up are tailored to each phase.

This steady increase in size and complexity of the project is reflected in a similar increase in size and complexity of the project organization. In fact, for truly large projects, it is now literally impossible to vest any one organization with full authority or responsibility for successful prosecution of the project. Program managers of such projects do not have line authority over all participating groups and, hence, cannot have responsibility for their performance.

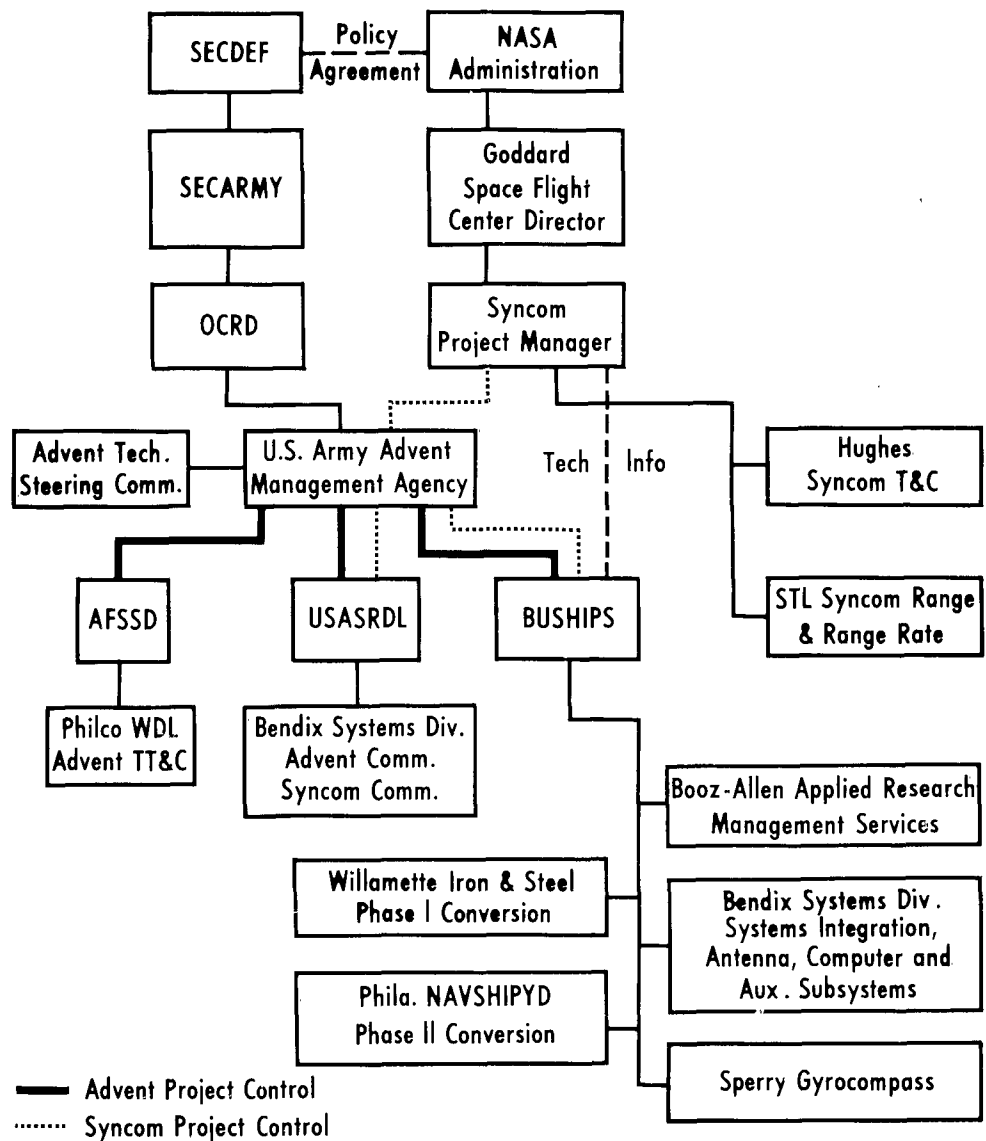

Figure 1

**PROJECTS ADVENT/SYNCOM MANAGEMENT
AS AFFECTING NAVY PARTICIPATION**

Four principal types or categories of program managers may be defined:¹

1. Project Expediter.
2. Project Coordinator.
3. Project (Confederation) Manager.
4. Project (General) Manager.

The first two types are of interest here, and are described as follows:² "(The project expediter) does not perform primary management functions, such as directing people, but he does perform two other activities essential to good management. First, he is supposed to expedite the work by dealing with all persons involved to assure that schedules are met; however, he has no power other than persuasion and reporting back to his superior. This reflects his second function, that of serving as a center of communication to be able instantly to report to general management on the whole of the project and thus relieve general management of the tedious task of keeping up with all the details. Accordingly, he accomplishes unity of communication, a key necessity in the complex world of advanced technology."

"(The project coordinator) has independent authority to act and is held responsible therefore, but he does not direct the work of others. He is more of a staff leader, exercising his leadership through procedural decisions and personal interaction, rather than through line authority. For example, he can independently, or in discussion with others, determine a schedule change and issue procedural changes relating thereto, somewhat like a production control department in a factory, but he cannot direct or discipline others. As another example, his signature may be necessary for release of budget monies, like a controller, but he does not originally set the budget. His control of the budget is perhaps his greatest strength. This forces a unity of control, in addition to the unity of communication which existed in the first type, the production expediter."

-
1. "The Role of Project Management in Scientific Manufacturing", Keith Davis, IRE Transactions on Engineering Management, September 1962, pp. 109-113.
 2. Ibid.

These descriptions have a corporate orientation, but it does not require much modification to apply them to the extremely large, national, inter-agency, and inter-service projects. It is to this type of project that the program status reporting and analysis approach described in this paper applies.

Project Status Reporting and Analysis Techniques

Along with the gradually increasing emphasis on project management has come the development of advanced management control procedures. These procedures make use of the major advances made in the last decade in computer technology, automatic data processing procedures, and operations research techniques. These methods include such items as Critical Path Method (CPM), Milestone Reporting Technique (MRT), Program Evaluation and Review Technique (PERT), Line of Balance (LOB), and PERT/COST and other PERT derivatives. There are several publications which describe these methods.³

The successful application of certain of these, specifically PERT and its variations, has tended to promote an attitude that their use is an absolute necessity for program success. Although there can be little doubt that their general value has been clearly established, unqualified selection of any one management tool for all types of programs is clearly not good management. As discussed in the preceding section, not all projects have similar organizational structure, technical characteristics, or management philosophies. Also, such considerations as the cost of implementing and maintaining the techniques selected, relative to total program cost, require careful attention.

The use of PERT by the Navy's Special Projects Office in the POLARIS program is regarded as having contributed substantially to the success of that very important and dramatically successful program. This fact has tended to obscure other aspects of the POLARIS program and its management which were also very important to this success.

3. DOD and NASA Guide, PERT COST, Systems Design, June 1962. NASA PERT and Companion Cost System Handbook, October 30, 1962.

While it cannot be said that PERT is inappropriate for programs unlike POLARIS, many important and complex defense programs possess characteristics which are almost the direct inverses of those of POLARIS. Some cut across many major Federal government departments, agencies, and bureaus. In such programs, full use of PERT might not be appropriate, and it may be extremely difficult or expensive to maintain.

The CAMERA Approach

Basically, the CAMERA approach makes use of the Milestone Reporting Technique (MRT).⁴ Its distinction from MRT is that, after reporting by various participants, the milestones are divided into various status categories (Completed, Behind Schedule, Cancelled, etc.). The report is then published and distributed to all participating agencies and contractors.

While this analysis of milestone status information and the distribution of the report to all parties might seem somewhat obvious, it is these procedures which provide CAMERA with its value to successful execution of a cooperating agencies project. It is essential, in the absence of strong central authority, that each participating agency and contractor have status information on the efforts of others. This is compatible with a management philosophy encouraging working-level coordination and decision-making, which is possible only where working levels are fully and promptly informed. Chains of command should be used only for decision in the event of failure or inability of lower levels to resolve difficulties.

Each milestone in the report includes the identities of the performing contractor, the prime contractor, and the cognizant agency or bureau. The report, therefore, also constitutes a periodic summary of actual performance of each participant, which is visible to all other participants. There are few motivations for good performance more powerful than knowledge that one's efforts are being reviewed by all

4. POLARIS Management, Special Projects Office, Department of the Navy, Washington, D. C., February 1961, p. 18.

team members. One ramification is that realistic schedule dates at the outset are encouraged. Another is that failure to report on a milestone, due for completion in a given report period, will result in that milestone being included, quite impartially, under Milestones Behind Schedule. Care and promptness in reporting are encouraged, even by top authorities responsible for milestone events such as:

APPROVE FY 64 FUNDING FOR XYZ SUBSYSTEM.

The effectiveness of the CAMERA approach is not dependent on the initial accuracy of the milestone definition, of the schedule, or of the organizational relations existing between participating contractors and agencies. The nature of the procedure makes it self-correcting, as will be explained later. This means that some control information can be defined and reported on within weeks of the start of a project, and that milestones can be added independently of other milestones. An operational control system is therefore available from the outset, attainable even with a very small staff.

In this connection, it should be noted that such techniques as PERT and CPM require intensive, protracted effort. The value of the network is dependent upon a uniform and high accuracy of data and relations between milestones and participants. The network structure and its accuracy are first in importance, with accuracy of the individual elements second and the nature of the elements (milestones) last. Furthermore, the network is not self-correcting; in fact, every non-trivial change to program schedules, fundings, or participation may degenerate the entire net and the value of any reports based on it. Consequently, high level and sustained effort is required to maintain it.

It should be noted that CAMERA does not replace or duplicate PERT. Virtually all the steps necessary to set up CAMERA are required in establishing PERT. The value of CAMERA in no way detracts from or alters the value of the network aspects of PERT or CPM. It would be completely in order to continue development of CAMERA milestones into a PERT or CPM network, and to generate summary PERT reports for high project management levels. CAMERA complements PERT; it may properly be called PRE-PERT.

The CAMERA approach is simple and straightforward. It is not time consuming, does not require extensively trained personnel at

either end, and is evolutionary and adaptable in nature. Establishment of the procedure involves the following phases:

- . Milestone Definition Phase.
- . Build-up and Correction Phase.
- . Sustained Reporting Phase.
- . Terminal Phase.

These phases are described in detail in Section IV.

II. BASIC CAMERA CHARACTERISTICS

II. BASIC CAMERA CHARACTERISTICS

Authority Required

Implementation of CAMERA does not require existence of explicit program control authority. It is necessary only to impose responsibility on the program manager for over-all program status reporting, and initially to assist him in obtaining the cooperation of personnel at critical program management levels.

The designation of reporting responsibility provides the basis for unilateral definition of milestones. The program manager or control office then needs only to assume the authority for distributing reports to all participating agencies and organizations. From this point on, the inherent properties of CAMERA can assure cooperation in obtaining corrections, expansions, and reports on milestones.

It should also be noted that the agencies associated with a milestone include the contractor doing the work and the organization required to report on its status. These two may, in fact, be one and the same. However, this procedure is necessary to avoid cutting across organizational levels, while preserving the program manager's right to define any milestone and his right to know the identity of the organization directly responsible for its performance. In general, the reporting agency will be one responsive to the program manager's needs and in the direct chain of command. Therefore, reporting requirements can be imposed in an orderly fashion following the chain of command.

On the opposite side of the coin, there will be milestones in which both the performing and reporting agencies are at a level of authority higher than that of the program reporting office. Milestones at such levels are often the most crucial ones in the program, that is, those pertaining to fund allocations, plan approvals, prime contractor selections, and responsible agency designations. In these cases, the program reporting office should have the right not only of defining the milestones, but also of identifying the higher responsible authorities and of establishing appropriate schedules for milestone completions.

Lack of approval of such definitions and schedules may delay establishment of major portions of the program plan, while failure either to report or to accomplish the milestones on schedule will result in the milestone being reported in the Behind Schedule portion of the CAMERA Report.

Self-Generation

It is not necessary for the program manager to originate all milestones. Each participant can submit for consideration any milestone which he deems desirable for reporting.

While a milestone-submitting agency may have considerable detail on each milestone, it is not necessary to provide more than the definition. When a milestone is submitted by a participant, the program manager can review it, assign a sequence number, add whatever information is available, and publish it as a new milestone in the next CAMERA Report.

As a milestone nears completion, it may become appropriate to replace it with more detailed tasks. The original is then considered cancelled, and the new ones are considered new milestones.

Self-Correction

From the view of the project manager, self-correction means that he need not take active and separate steps to correct errors. He tailors the milestone list to precisely those activities he deems of particular or general importance, using the most authoritative and current information available on each. It is not essential to consider preceding or succeeding events. After defining the activity or event, he attaches the name of the contractor actually assigned to perform the work, or leaves it blank if unknown or not yet assigned. Other items added are: the identity of higher echelons of prime contractor, cognizant agency, bureau or code, and sponsoring agency or service; anticipated completion or execution date; authorizing contract, directive, or instruction; estimated elapsed time to complete; or any other category of information. In each case, the column space is filled in

according to best information. If no information is available, or in the absence of assignments or documents, the space is left blank. During initial phases, an accompanying letter may be used to note the possibility of errors, and to solicit corrections and amendments.

When the CAMERA Report is published, it will be scrutinized by all responsible personnel and agencies. It is here that the self-correcting aspect of CAMERA begins. Each participant will be quick to point out corrections or amendments. This factor is extremely important to the program manager. In effect, his own staff is augmented by every informed and responsible individual receiving the CAMERA Report.

For example, the XYZ Company may have been listed as the contractor of Milestone 123, which is scheduled for completion 23 May 1964. The project director of the XYZ Company can inform the over-all program manager that the ABC, not XYZ, Company, has the task according to letter so and so; that the due date is incorrect according to document such and such; or that Agency A, not Agency B, is responsible for funding approval.

When such corrections are indicated, they should be checked by the office of the program manager, and necessary corrections made prior to the issuance of the next CAMERA Report. These procedures, conducted on a continuing basis, provide CAMERA Reports with increasing accuracy and authority. Also, this self-correcting property will not decay--it will remain fully effective so long as CAMERA Reports are distributed to all participating contractors and agencies.

The initial correcting process can be greatly accelerated by holding periodic Milestone Review Conferences attended by informed and responsible representatives of each participant.

Self-Organization

Each milestone includes information on its contractors and agencies, completion dates, subsystem or subproject, etc. As the quantity and accuracy of milestones increase, arrangements under these various categories will reveal a program structure and order which will be the result of the detailed and independent planning and reviewing activities of many individuals.

These characteristics are invariant through the process of program changes and reorientations. The value of CAMERA does not depend upon accuracy and structure; rather, structure and accuracy are results of its application.

Ease and Speed of Report Preparation

One of the categories in each CAMERA report is Milestones Due Next Report Period. Milestones included are not only those originally scheduled, but also new, rescheduled, and behind schedule milestones. They are arranged by reporting agency, by performing contractor under each reporting agency, and by due date under each performing contractor.

This section comprises a schedule of events to be completed during the forthcoming period by each performing contractor, and a check list of milestones to be reported on by each reporting agency. This simplifies the preparation of the succeeding CAMERA Report and permits status reporting to be done by clerical personnel.

Flexibility

Because there is no need for a structure, CAMERA is especially useful for those projects which are of an evolutionary, rather than a fixed, clearly defined, nature. Partial or interim capability, system growth, and program changes may be incorporated into the reporting procedure with a minimum expenditure of time and money. Considered from this point of view, CAMERA incorporates fairly standard "File Maintenance" to automatic data processing procedures.

III. THE CAMERA INFORMATION ELEMENTS

III. THE CAMERA INFORMATION ELEMENTS

The Milestone Unit Record

Each milestone has certain information associated with it. The extent of such associated information can be tailored to each individual program. This information for a given milestone will be referred to as the Unit Record for that milestone. The following are the items of information used on the Navy Communications Satellite Program, and can be considered basic.

It is necessary that the Unit Record include everything necessary to identify each milestone. Since milestones are listed under different report categories, items such as subsystem or project must be incorporated in each appropriate milestone Unit Record. It is not sufficient for appropriate milestones to be "listed" under a subsystem heading.

Identification Number

The identification number is not significant. All information is encoded and included with the milestone Unit Record, and this information is the basis for subsequent ordering or structuring. Simple sequential numerals are used; letters or combined alphanumerics could also be used. It should be noted, however, that when significance (e. g., subsystem) is attached to the identification, it becomes coded information. This tends to complicate assignment of numbers as milestones are added. Sequential numbers are recommended.

Milestone Definition

As used in CAMERA, a milestone may define either an activity or an event. If an activity is defined, the date given is the scheduled completion date; i. e., the milestone event to which the date refers is the completion date of the activity defined. Examples are such activities characterized by the verbs Prepare, Review, Conduct.

Whenever possible, a milestone should define an event; the date given is then the scheduled execution date. Examples are such events characterized by the verbs Submit, Approve, Ship, Receive.

The milestone definition consists of three parts: the action, the subsystem or subproject, and the milestone description.

Action

The action is described by a verb. Preference is given to use of an active verb at the beginning of the milestone proper. The use of "complete" should be avoided, since the scheduled dates are completion dates. The word "complete" is, therefore, redundant, and its use may replace a verb more descriptive of the action to be taken in the actual milestone. In some cases, "complete" might camouflage an activity which may have no real completion date.

Establishing the verb as a separate part of the milestone makes it possible to break out milestones such as CONDUCT (Tests), PREPARE (Reports), SUBMIT (Documents), SHIP (Components), or INSTALL (Equipment) for special reports or reference listings.

Subsystem or Subproject

Most programs have at least one level in which subsystems are named or specified. Large programs may have several levels of subsystem or components.

Arrangement by subsystem permits a close look at the status of each subsystem; it is also a step in preparation of a PERT network.

Milestone Description

The action (verb) and subsystem are parts of the milestone. These are augmented by whatever information is necessary to define the full milestone activity or event. Examples are names of documents, tests, or destinations.

Contractor and Agency Identification

CAMERA requires information on the organizations associated with each task or milestone. DOD Instruction 3200.6, dated 7 June 1962, defines the participants.

Performing Contractor

This is the contractor, government laboratory, or agency responsible for performing the action specified in the milestone.

Reporting Agency

This is the prime contractor or government directing agency having immediate contractual responsibility and technical supervision over the task or action specified in the milestone. This organization is responsible for reporting on the status of the milestone. If chains of command are not violated, the performing and reporting organizations may be identical.

Action Agency

This is the bureau, office, technical source, command, or headquarters under whose sponsorship or responsibility the project is being pursued.

Completion of Execution Dates

For each milestone identified for CAMERA use, certain dates should be recorded. Most important is the estimated completion date established during the original planning. Where original completion dates have been rescheduled, the current dates should be recorded.

A list of important dates follows:

Original Schedule. The date established during the original planning.

Rescheduled. Approved schedule slide. This date will appear under current schedule column in succeeding CAMERA Reports.

Current Schedule. The latest approved date.

Actual. The actual completion or execution date for a completed milestone.

Reporting Level or Special Report

This identifies milestones to be drawn from the entire file for generation of a briefer or more specialized report for higher authority or special purposes. (See "Milestone Status Analysis and Report Format" and "Special Reports and Reference Listings" on pages 18 and 25.) This makes preparation of such a report extremely simple, since no additional information is required, and the identical automatic procedure is followed in its preparation.

References and Documents

A coded number, which references a list of authorizing documents, contracts, or other documentation pertinent to the milestone, may be included in the Unit Record.

Status Information

Prior to each CAMERA Report, status information is reported by each reporting contractor. This is used to up-date the Milestone Unit Record File, and is the basis for the CAMERA Report. Status information includes the following.

Completed Milestones

Information submitted should include ID number of each completed milestone and the completion date. If the date is not provided, the last day of the report period may be used.

New Proposed Milestones

All pertinent information should be given. If approved, this milestone will appear under New Milestones.

Discontinued Milestones

Milestone number and reason for discontinuance are given. If approved and not re-assigned, this will appear in the Cancelled Milestones.

Delayed Milestones

ID number, target date, and reason for delay are given.

Ahead of Schedule

ID number and target date are shown.

Milestone Status Analysis and Report Format

Management personnel must be on top of the program under their control. Therefore, they need to know certain specific information. This includes status of the program with regard to:

1. Completion dates of all tasks within the program, regardless of the category of control being exercised over the tasks. These dates should be shown as original, current, or actual completion (execution) dates.
2. Revised task completion dates on all tasks not capable of being completed on schedule. The manager needs to know rescheduled, delayed, and advanced dates for task completions, so that effects of new dates can be assessed in terms of the over-all program.
3. Cancelled tasks and new tasks appearing within the program.

The analysis of milestone status will result in groupings of all milestones, each group having a given status. This milestone grouping is the basis of CAMERA reporting, and dictates the format discussed in the following paragraphs.

Cancelled Milestones

The first grouping in the CAMERA Report is a listing of all milestones cancelled since the last CAMERA Report. These are determined or approved by the program manager or his immediate supervisor. Those milestones replaced by several detailed milestones are considered cancelled. Replacement milestones will appear under New Milestones. Identification numbers should not be re-used. This section is arranged in numerical order of identification number. See Figure 2.

New Milestones

New milestones added since the preceding CAMERA Report are shown here. Prior to listing, each new milestone must be approved by the program manager or his immediate supervisor, although they may be recommended by other agencies and organizations. Identification numbers are assigned in sequence, and arranged in that order. See Figure 3.

Completed Milestones

All milestones completed or reported completed since the preceding CAMERA Report are contained in this section. Milestones are arranged in numerical order of ID number. See Figure 4.

Milestones Behind Schedule

This section includes all milestones which are behind their schedules. They are arranged by performing contractor and ID number. See Figure 5.

Rescheduled Milestones

Milestones whose completion dates have been rescheduled with the approval of the program manager, his immediate supervisor, or the appropriate milestone controller are listed here. Milestones are arranged in ID number order. See Figure 6.

NAVY PARTICIPATION IN PROJECTS ADVENT/SYNCOM

BUREAU OF SHIPS

MILESTONE REPORT FOR PERIOD 21 NOV - 20 DEC 1962

CANCELLED MILESTONES

| CONTR | MILESTONE | REPT | ORIG | CURR | |
|-------|---------------------------------------|------|---------|---------|---------|
| * 322 | BSD PREPARE ADV COMM OPERATION MANUAL | BSD | 11 01 2 | 12 10 2 | HUSHIPS |

Figure 2 SAMPLE PAGE-CANCELLED MILESTONES

NAVY PARTICIPATION IN PROJECTS ADVENT/SYNCOM

BUREAU OF SHIPS

MILESTONE REPORT FOR PERIOD 21 OCT - 20 NOV 1962

NEW MILESTONES

| CCNTR | MILESTONE | REPT | ORIG | CURR | |
|-------|-------------------------------------|------|---------|---------|---------|
| 374 | PREPARE TEST EQUIP SPARE PARTS LIST | BSD | 12 01 2 | 12 01 2 | BUSHIPS |

Figure 3 SAMPLE PAGE-NEW MILESTONES

NAVY PARTICIPATION IN PROJECTS ADVENT/SYNCOM

BUREAU OF SHIPS

MILESTONE REPORT FOR PERIOD 21 NOV - 20 DEC 1962

COMPLETED MILESTONES

| CONTR | MILESTONE | REPT | ORIG | CURR | ACTUAL |
|-------|--------------------------------------|------|---------|---------|-----------------|
| * 67 | BUS APPROVE SYSTEM FINAL ACC DTP | BSD | 6 15 2 | 9 01 2 | 10 22 2 BUSHIPS |
| * 85 | WDL SUBMIT ADV TT&C SHIPYD TR | WDL | 10 15 2 | 12 15 2 | 12 08 2 USAFSSC |
| 114 | ESC SUBMIT FINAL SPARES LIST | | 3 01 2 | 10 15 2 | 12 17 2 BUSHIPS |
| 122 | BRD PREPARE SYNCOM COMM TECH MAN | BRD | 5 15 2 | 11 01 2 | 11 30 2 USASRDL |
| * 123 | STL PREPARE SYNCOM R&R TM | STL | 5 15 2 | 12 07 2 | 12 21 2 NASA |
| * 230 | CONDUCT SHIPYARD SUBSYSTEM TESTS | BSD | 10 01 2 | 10 19 2 | 12 23 2 BUSHIPS |
| * 234 | BSD CONDUCT CLEAR MODE EQUIP TEST | BSD | 10 01 2 | 12 01 2 | 12 01 2 BUSHIPS |
| 237 | BRD CONDUCT SYNCOM COMM EQUIP TEST | BSD | 9 01 2 | 12 01 2 | 12 01 2 BUSHIPS |
| 253 | PSY LOAD TEST EQUIPMENT | PSY | 10 01 2 | 12 10 2 | 12 15 2 BUSHIPS |
| 255 | PSY SHIP READY FOR SEA | PSY | 11 01 2 | 12 15 2 | 12 20 2 BUSHIPS |
| * 337 | WDL DEL ON BOARD REPAIR PARTS TO PSY | PSY | 11 01 2 | 12 15 2 | 12 15 2 USAFSSC |
| * 339 | HAC DEL ON BOARD REPAIR PARTS TO PSY | PSY | 11 01 2 | 12 15 2 | 12 15 2 NASA |
| * 340 | STL DEL ON BOARD REPAIR PARTS TO PSY | PSY | 11 01 2 | 12 15 2 | 12 15 2 NASA |

Figure 4 SAMPLE PAGE-COMPLETED MILESTONES

NAVY PARTICIPATION IN PROJECTS ADVENT/SYNCOM

BUREAU OF SHIPS

MILESTONE REPORT FOR PERIOD 21 NOV - 20 DEC 1962

MILESTONES BEHIND SCHEDULE

| CGNTR | MILESTONE | REPT | ORIG | CURR | |
|-------|--------------------------------------|------|---------|---------|---------|
| * 115 | PREP TECHNICAL MANUALS | | 8 01 2 | 11 01 2 | BUSHIPS |
| 232 | BSD CONDUCT COMPUTER SUBSYSTEM TEST | BSD | 10 01 2 | 12 01 2 | BUSHIPS |
| * 338 | BSD DEL ON BOARD REPAIR PARTS TO PSY | SCG | 11 01 2 | 12 15 2 | BUSHIPS |
| 341 | BRD DEL CN BRD RPR PRTS TO PSY | SCG | 11 01 2 | 12 15 2 | USASRDL |

Figure 5 SAMPLE PAGE-MILESTONES BEHIND SCHEDULE

NAVY PARTICIPATION IN PROJECTS ADVENT/SYNCOM

BUREAU OF SHIPS

MILESTONE REPORT FOR PERIOD 21 NOV - 20 DEC 1962

RESCHEDULED MILESTONES

| CONTR | MILESTONE | REPT | ORIG | CURR | REVISED |
|-------|---|------|---------|---------|-----------------|
| * 78 | PREPARE SHIPYD SUBSYST TEST REPORTS | BSD | 12 01 2 | 12 01 2 | 1 01 3 BUSHIPS |
| 79 | GEO SUBMIT ANTENNA SUBSYSTEM SYTR | BSD | 11 15 2 | 12 15 2 | 1 15 3 BUSHIPS |
| 80 | BSD SUBMIT COMPUTER SUBSYSTEM SYTR | BSD | 10 15 2 | 11 23 2 | 1 15 3 BUSHIPS |
| 81 | BRD SUBMIT CLEAR MODE SYTR | BSD | 11 15 2 | 12 15 2 | 1 07 3 BUSHIPS |
| 82 | BRD SUBMIT SYNCOM COMM SYTR | BSD | 12 01 2 | 12 01 2 | 1 07 3 BUSHIPS |
| 84 | BRD SUBMIT HP AMPL SYTR | BSD | 11 15 2 | 12 15 2 | 1 07 3 BUSHIPS |
| * 243 | BSD CONDUCT SHIPBD TERM FINAL ACC TEST | BSD | 10 01 2 | 11 30 2 | 12 21 2 BUSHIPS |
| 252 | SCG LOAD TERMINAL SYSTEM SPARES | SCG | 12 01 2 | 12 10 2 | 12 28 2 BUSHIPS |
| * 324 | BRD PREP SHIPBOARD TERMINAL OP MANUAL | BSD | 11 01 2 | 12 01 2 | 12 28 2 USASRDL |
| * 334 | DELIVER TEST EQUIPMENT TO PHILA | SCG | 7 01 2 | 12 15 2 | 1 15 3 BUSHIPS |
| * 369 | GEO CONDUCT SYNCOM ANT SUBSYSTEM TEST | BSD | 11 06 2 | 12 01 2 | 12 21 2 BUSHIPS |
| 374 | ESG PREPARE TEST EQUIP SPARE PARTS LIST | BSD | 12 01 2 | 12 01 2 | 1 15 3 BUSHIPS |

Figure 6 SAMPLE PAGE-RESCHEDULED MILESTONES

Milestones Due Next Report Period

Active milestones due for completion during the report period, as well as behind schedule milestones are included here. They are arranged in order of reporting or directing agency, performing contractor, and due date. See Figure 7.

Active Milestones by Subsystem

All active milestones are arranged by the subsystem and due date. See Figure 8.

Special Reports and Reference Listings

Since milestones can be tagged with identifying action information a CAMERA Report in abbreviated form can be prepared for each higher authority or special interest group by following the identical procedure used in the preparation of the over-all report. In addition, the various categories of information included in the Unit Record permits preparation of special reports of:

- . All milestones to be performed by a given contractor or implementing agency.
- . All milestones falling within a specified time frame.
- . All milestones in which equipment is shipped, delivered, received, installed, and tested.
- . All milestones involving acceptance tests.
- . All milestones in which a given agency is a participant.
- . All milestones which have been rescheduled in the entire program.
- . All behind schedule milestones by contractor or implementing agency. This may provide a basis for performance evaluation.

NAVY PARTICIPATION IN PROJECTS ADVENT/SYNCOM

BUREAU OF SHIPS

MILESTONE REPORT FOR PERIOD 21 NOV - 20 DEC 1962

MILESTONES DUE NEXT REPORT PERIOD

| CONTR | MILESTONE | REPT | ORIG | CURR | |
|-------|-------------------------------------|------|---------|---------|---------|
| BSD | GENDIX SYSTEMS DIVISION | | | | |
| * 78 | PREPARE SHIPYD SUBSYST TEST REPORTS | BSD | 12 01 2 | 1 01 3 | BUSHIPS |
| 79 | SUBMIT ANTENNA SUBSYSTEM SYTR | BSD | 11 15 2 | 1 15 3 | BUSHIPS |
| 80 | SUBMIT COMPUTER SUBSYSTEM SYTR | BSD | 10 15 2 | 1 15 3 | BUSHIPS |
| 81 | SUBMIT CLEAR CODE SYTR | ASD | 11 15 2 | 1 07 3 | BUSHIPS |
| 82 | SUBMIT SYNCOM COMM SYTR | BSD | 12 01 2 | 1 07 3 | BUSHIPS |
| 84 | SUBMIT HP AMPL SYTR | BSD | 11 15 2 | 1 07 3 | BUSHIPS |
| 232 | CONDUCT COMPUTER SUBSYSTEM TEST | BSD | 10 01 2 | 12 01 2 | BUSHIPS |
| * 243 | CONDUCT SHIPBD TERM FINAL ACC TEST | BSD | 10 01 2 | 12 21 2 | BUSHIPS |
| * 324 | PREP SHIPBOARD TERMINAL OP MANUAL | BSD | 11 01 2 | 12 28 2 | USASRDL |
| * 369 | CONDUCT SYNCOM ANT SUBSYSTEM TEST | BSD | 11 06 2 | 12 21 2 | BUSHIPS |

Figure 7 SAMPLE PAGE-MILESTONES DUE NEXT REPORT PERIOD

NAVY PARTICIPATION IN PROJECTS ADVENT/SYNCOM

BUREAU OF SHIPS

MILESTONE REPORT FOR PERIOD 21 NOV - 20 DEC 1962

ACTIVE MILESTONES BY SUBSYSTEM

| CONTR | MILESTONE | REPT | ORIG | CURR | |
|-------|--|------|---------|---------|---------|
| | SHIP TERMINAL SYSTEM MAINTENANCE AND OPERATION | | | | 05 |
| * 338 | BSD DEL ON BOARD REPAIR PARTS TO PSY | SCG | 11 01 2 | 12 15 2 | BUSHIPS |
| 341 | BRD DEL ON BRD RPR PRTS TO PSY | SCG | 11 01 2 | 12 15 2 | USASRDL |
| * 324 | BRD PREP SHIPBOARD TERMINAL OP MANUAL | BSD | 11 01 2 | 12 28 2 | USASRDL |
| * 334 | DELIVER TEST EQUIPMENT TO PHILA | SCG | 7 01 2 | 1 15 3 | BUSHIPS |
| 374 | ESD PREPARE TEST EQUIP SPARE PARTS LIST | BSD | 12 01 2 | 1 15 3 | BUSHIPS |

Figure 8 SAMPLE PAGE-ACTIVE MILESTONES BY SUBSYSTEM

IV. APPLICATION OF CAMERA PROCEDURES

IV. APPLICATION OF CAMERA PROCEDURES

General

The application of CAMERA to a given project is a simple and straightforward process. Milestones can be defined by anyone who can read directives and planning documents; special training is not required. The procedure may be manual, but a computer program is uncomplicated, fast, accurate, and makes possible special reports or listings. If a computer routine is available, the procedure for even a large and complex program can be administered by one competent clerk.

Initial or Definition Phase

It is first necessary to determine the extent of the information to be obtained on each milestone and included in the Unit Record. A key-punch form must be designed (see Figure 9) and a supply given to the individuals charged with the initial milestone definition.

Source materials include all official directives, plans, planning documents, milestone schedules, personnel interviews, and milestone schedules of similar programs or projects (the milestone definition only). A list of reference documents should be compiled and authority for each milestone activity incorporated into the Unit Record.

A list of participants and their numeric abbreviations should be compiled. In general, reference tables for all coded information must be established.

Prior to the first release, the milestone list can be reviewed by various informed personnel for additions and corrections.

Build-Up and Correction Phase

Following the initial definition, it is doubtful if there will be much activity in a new program. This provides an opportunity for a build-up of the list, and correction and completion of each Unit Record. In the event of no activity (from performing contractors) at all, the CAMERA Report will reduce to New Milestones and Active Milestones (with possible Unassigned, Unscheduled, or Incomplete categories) during this period. Distribution of duplicate copies will permit mark-up and return--a fast, informal way of correcting and completing Unit Records.

This period may also be used to compile a file of project director names, phone numbers, locations (cities), and other information. Such information, attached as an appendix to each report, will speed the establishment of working level and informal, but effective, communication channels.

At the conclusion of this phase--usually a few months--the program will be well defined. A working, accurate information and control system will have been established, and detailed information will be at hand for construction of a PERT or CPM network.

Sustained Operations

A particularly attractive asset of the CAMERA sustained reporting phase is the informality of the communications channels which can be used. In fact, communication informality is desirable, since transmittal times of memoranda through a complex control structure may result in serious delays in status information.

The procedure for the actual collection of status information may vary from telephoning the reporting agency to using a TWX network with punched paper tape subsequently fed directly to a computer or automatic data conversion device. The first run may be designed specifically for the program manager, enabling him to make decisions on new, cancelled, or rescheduled milestones.

It also provides him with an opportunity to set up meetings and reviews and to take corrective action prior to issuance of the CAMERA Report proper.

It is probable that, in addition to the full report, condensed reports will be prepared for higher authority, using the identical basic information. With a mechanized computer operation, no special procedures are required, since the milestones to be reported are tagged and will be selected from the entire file. Similar remarks apply to any special report, so long as the basic milestone information is included in the Unit Record.

The final report may be completely printed by the computer or suitable peripheral gear, requiring only continuous form bursting and binding. Depending on equipment used, the required number of copies may be produced by re-runs, or the report may be printed directly in reproducible form, such as lithographic masters.

Terminal Phase

Completion of a project does not mean an end to a program manager's job. There are many clean-up tasks to be done, particularly in such areas as obtaining and disposing of documentation. CAMERA offers a convenient, inexpensive means of assigning and keeping track of these many important loose-end activities.

V. REPORT PREPARATION

V. REPORT PREPARATION

General

Computer Programs

The preparation of a CAMERA Report includes the following general steps:

1. Obtain milestone status information, corrections, and amendments.
2. Analyze and segregate milestones according to status category (Completed, Behind Schedule, etc.).
3. Prepare report.
4. Reproduce and distribute report.

While manual processing is feasible for small programs, the use of automatic data processing equipment so simplifies the work that a single individual can perform all human effort required. Accordingly, two computer program segments were written for preparation of CAMERA Reports under BuShips Code 360A sponsorship. Further programming, although highly desirable, was not feasible because of limited time, funds, and computer configuration.

Current Status

The IBM 1401 computer was selected because of its widespread availability and relatively low cost. In order to further minimize cost and maximize flexibility, the programs were written for a minimum configuration. Neither program makes use of magnetic tape units. The first program--UPDAT--is designed to accept cards punched with milestone and status information. It generates the additional cards needed for the final report, with each card corresponding to one line

under an appropriate status category. After some manual sorting and arranging, these cards, together with appropriate title and header cards, are used by the second program--REPRT--which prints the entire report on the on-line printer.

Program Expansion

Additional programming currently contemplated will:

1. Require a larger configuration of IBM 1401, including magnetic tape transports, for performing the sorting function currently being done by manual sorters (e. g. , IBM 101)
2. Specify magnetic tape, in lieu of punched cards, for the milestone file, report tables, and headers.
3. Provide full file maintenance (updating) capability.
4. Provide for an expansion of CAMERA capabilities in general--for example, additional milestone information, additional report categories, a statistical summary, and performance evaluation based on statistical scores of status information.

Milestone File and Card Decks

The CAMERA programs and procedures currently use card decks for the various files of information required. These will be described in this section.

The Unit Record

All of the information pertinent to a given milestone is included in the Unit Record. The Unit Record is a punched card (see Figure 10) with the following information (columns not designated are not used):

| <u>Card Columns</u> | <u>Explanation</u> |
|---------------------|-------------------------------------|
| 1-5 | Identification number |
| 7-9 | The performing contractor or agency |

| <u>Card Columns</u> | <u>Explanation</u> |
|---------------------|---|
| 11-45 | Milestone description |
| 47-49 | The reporting contractor or agency |
| 51-57 | Original scheduled completion date (e. g. , 06-15-3) |
| 59-65 | Current scheduled completion date |
| 67-73 | Blank (Used for status information) |
| 74 | Special Report Tag |
| 75 | Action Agency Code |
| 76-77 | Subsystem Code |
| 78-79 | Action Code (e. g. , FABRICATE, INSTALL) |
| 80 | Blank (Used for status information) |

For future reference, this deck of cards will be called the MLSTN deck.

Report Title Cards

These cards are used by the REPRT program to print the project title, sponsoring agency, report security classification, report period, or similar information at the top of each page of the report. See Figure 11a. This deck is different for each project on which CAMERA is used, but does not change from month to month. For future reference, this deck will be called the TITLE deck. TITLE cards are punched with + or 12 punch in column 80, and an identifying code number in column 79, as follows:

NAVY PARTICIPATION IN PROJECTS ADVENT/SYNCOM
 CONFIDENTIAL
 BUREAU OF SHIPS
 MILESTONE REPORT FOR PERIOD FEB 21 - MAR 20 1963

| CONTR | MILESTONE | REPT | ORIG | CURR | ACTUAL |
|-----------|-----------|------|------|------|-----------|
| CONTR | MILESTONE | REPT | ORIG | CURR | REVISED8+ |
| 1+ | | | | | |
| 2+ | | | | | |
| 3+ | | | | | |
| 4+ | | | | | |
| 5+ | | | | | |
| 6+ | | | | | |
| REVISED8+ | | | | | |

(a)

CANCELLED MILESTONES
 NEW MILESTONES
 COMPLETED MILESTONES
 MILESTONES BEHIND SCHEDULE
 RESCHEDULED MILESTONES
 UNSCHEDULED MILESTONES
 MILESTONES DUE NEXT REPORT PERIOD
 ACTIVE MILESTONES BY SUBSYSTEM

J
L
M
N
O
P
Q
R

(b)

SATELLITE COMMUNICATIONS SHIP AG-164
 SHIP TERMINAL SYSTEM
 SHIP TERMINAL SYSTEM INTERFACES
 SHIP TERMINAL SYSTEM MAINTENANCE AND OPERATION
 ANTENNA SUBSYSTEM
 COMPUTER SUBSYSTEM
 COMPUTER SUBSYSTEM MK19-4A GYROCOMPASS
 COMPUTER SUBSYSTEM AN/UJK-1 COMPUTER
 COMPUTER SUBSYSTEM CONTROL AND DISPLAY CONSOLE
 INTERLOCK AND RADIATION WARNING SYSTEM
 TELEPHONE SYSTEM
 SYNCOM COMMUNICATIONS EQUIPMENT
 SYNCOM RANGE AND RANGE RATE EQUIPMENT
 SYNCOM T+C EQUIPMENT

00 I
01 I
04 I
05 I
30 I
40 I
42 I
43 I
46 I
51 I
52 I
J7 I
J8 I
K7 I

(c)

RSD RENDIX SYSTEMS DIVISION
 RUP RUPFAU OF SHIPS
 SCG SATELLITE COMMUNICATIONS GROUP
 WDL WESTERN DEVELOPMENT LABORATORIES PHILCO CORP

(d)

END

(e)

3092130420

D

Figure 11

| <u>Col. 79</u> | <u>Explanation</u> |
|-------------------|--|
| 1 | Name of Report or Project, and the initial line of every page. |
| 2 | Report security classification, the left hand side of the second line. |
| 3 | Sponsor of report, the center of the second line. |
| 4 | The report period, dates, the third printed line on every page of the report. |
| 5 } 6 } 8 } | Different columnar headings for the report. One of these will be the fifth printed line on every page. |

TITLE Cards are punched as follows:

| <u>Length of card field</u> | <u>Explanation</u> | <u>Col. 79</u> | <u>Col. 80</u> |
|-----------------------------|-------------------------------|----------------|----------------|
| 02-46 | Name of Program | 1 | + |
| 02-13 | Classification of Report | 2 | + |
| 02-16 | Sponsoring Agency | 3 | + |
| 02-51 | Report Period Dates | 4 | + |
| 02-78 | Normal Column Headings | 5 | + |
| 02-78 | "Completed" Column Headings | 6 | + |
| 02-78 | "Rescheduled" Column Headings | 8 | + |

Status Header Cards

These are used by the REPRT program to print the status category title on line 4 of each page of the report. These categories correspond to the code numbers punched in column 80 of the MLSTN deck. Some of these are handpunched, and some are punched by the UPDAT program. See Figure 11b.

It is this categorization of milestones by status which is the essence of the CAMERA approach.

The codes and headings currently in use are given below. The wording of the headings may be changed; however, the basic meanings assigned to the codes as indicated by these headings cannot be changed without corresponding changes to the UPDAT program. For future reference, this deck will be called the STATUS deck.

A STATUS description may make use of the entire card field, although those suggested below do not. Thus, a more complete description may be used if desired.

| <u>Card Columns</u> | <u>Subheading</u> | <u>Col. 80</u> |
|---------------------|-----------------------------------|----------------|
| 2-79 | Cancelled Milestones | J |
| 2-79 | New Milestones | L |
| 2-79 | Completed Milestones | M |
| 2-79 | Milestones Behind Schedule | N |
| 2-79 | Rescheduled Milestones | O |
| 2-79 | Unscheduled Milestones | P |
| 2-79 | Milestones Due Next Report Period | Q |
| 2-79 | Active Milestone by Subsystem | R |

Subsystem Header Cards

These are used by the REPR program to print the subsystem description on line 6 of the section called Active Milestones by Subsystem. The subsystem description corresponds to the code number punched in columns 76-77 of each milestone card. This deck will be referred to as the SUBSYS deck.

A SUBSYS header card may use columns 1-75 for the subsystem description. The subsystem code is punched in columns 76-77, and column 80 must contain an "I". See Figure 11c.

Contractor and Agency Abbreviations

A three-letter code should be assigned to each of the various contractors and agencies participating in the program. Air Force Manual 171-11 suggests the use of standard abbreviations. These are used in columns 7-9 and 45-47. The REPR program includes the capability of:

1. printing the definition of these abbreviations as subheadings under report section, Milestones Due Next Report Period (line 6), and
2. printing a complete list of abbreviated lines used at the end of the report.

The card should have the abbreviations punched in columns 7-9, the full name in columns 13-75, and an "H" in column 80. This deck will be referred to as the ABBR deck. See Figure 11d.

Current Procedure

Collecting Status Information

The procedure for the preparation of a report starts with the collection from the reporting agencies (punched in columns 47-49 of the Unit Record Card) of milestone status information. The exact procedure may range from making informal telephone calls to use of TWX network. In the Navy Satellite Communications Ship program, letters were sent to each reporting agency, with a follow-up telephone call to obtain the specific up-to-the-minute status information.

Status information on a milestone may be one of four kinds:

1. The ID number of a completed milestone, with the actual completion date,
2. The ID number of a discontinued milestone,
3. The milestone description and other information on a proposed new milestone, or
4. The ID number and target completion date of milestones proposed for rescheduling.

This information is punched on cards as described in UPDAT Program Description. See Figure 12.

UPDAT Program

After the status information is punched on cards, a DATE card is punched, containing the end dates of the current and next report periods. The UPDAT program can then produce a deck of all the milestone cards which will be required for the report. In addition to this deck, an on-line listing of all the cards in the deck is produced, so that a preliminary check can be made prior to manual processing and running of the REPRT program.

The foregoing procedure may be summarized as follows:

1. Punch status information in MLSTN deck.
2. Punch DATE card.
3. Run UPDAT on IBM 1401 computer. Card deck to be used should consist of:
 - a. Binary UPDAT deck
 - b. DATE card
 - c. Updated MLSTN deck
 - d. END card.

The output resulting from the foregoing will consist of an on-line print-out of all milestone cards as they were punched, and four distinct card decks:

- . Updated MLSTN deck in the Normal Read Stacker (See 3-6).
- . Milestone cards for condensed Higher Authority CAMERA Report in Punch Stacker 8.
- . New MLSTN deck; i. e. , active milestone cards for preparation of next month's CAMERA Report, in Punch Stacker 4. (Used in steps 1 and 3-6 following month.)
- . Milestone cards for this month's CAMERA Report in the Normal Punch Stacker (Called Deck A).

Manual Procedure

Pending further programming work, the next steps are manual, and result in a deck arranged to be used by the REPRT program. These manual steps are as follows (numbered from previous section):

4. Place STATUS deck in front of Deck A, and sort numeric on column 80.
5. Remove cards from sorter pockets 1-7, keeping them arranged in ascending order of the numeric punch in column 80. Call this Deck 1-7.
6. Remove cards from sorter pocket 8. The first card of this deck should read Milestones Due Next Report Period. Call this Deck 8.
7. Remove cards from sorter pocket 9. The first card of this deck should read Active Milestones by Sub-system. Call this Deck 9.
8. Sort Deck 8 on columns 47-49 (alphabetic).
9. Place the appropriate card from the ABBR deck in front of each subdeck.

10. Sort Deck 9 on col. 63, 62, 60, 59, 65 (numeric).
11. Place SUBSYS Deck in front of Deck 9.
12. Sort this combination deck on columns 76-77 (numeric).
13. Combine this and previous decks in following order:
 - (1) Deck 1-7
 - (2) Deck 8 (sorted and categorized by reporting agency)
 - (3) Deck 9 (sorted and categorized by subsystem)

Call this the DATA deck.

REPRT Program

To produce the final CAMERA Report, arrange the program and various card decks in the following order:

- (1) Binary REPRT Deck
- (2) TITLE Deck
- (3) DATA Deck
- (4) END Card
- (5) ABBR Deck
- (6) END Card

Run this deck on IBM 1401 computer. For machine adjustments and general program operating instructions, refer to REPRT Program Description.

UPDAT Program Description⁵

Input Preparation

Binary UPDAT Deck

This deck, which is called the object program, is obtained by compiling the source program on the 1401 computer. The source program is the program as written by the programmer; the object program is the translation of this language to binary machine language. Figure 13 is a listing of the source program. A loader deck precedes the actual UPDAT deck.

DATE Card

This is a single card which has the end date of the current report period, and that of the next report period punched in it. See Figure 11f. Card format is as follows:

| <u>Card Column</u> | <u>Explanation</u> |
|--------------------|-------------------------------|
| 1-5 | End date - this report period |
| 1 | Terminal digit of year (3) |
| 2-3 | Month (January = 01, etc.) |
| 4-5 | Day (01, 02, etc.) |
| 6-10 | End date - next report period |
| 80 | Letter "D" |

5. "Milestone Update", Mildred E. Francis, Booz-Allen Applied Research, Inc., August 13, 1962.

CLEAR STORAGE 1
 CLEAR STORAGE 2
 BOOTSTRAP CARD

008015,022026,030034,041,045,053,0570731026
 072116,110106,105117B1C1/199,027A0740281027800102708026/0991,001/00111710
 008015,022029,056063/056029
 0240671056

| PG | LN | CT | LABEL | OP | A OPERAND | B OPERAND | D | LOC | INSTRUCTION | COMMENTS |
|----|-----|----|-------|-----|-----------|-----------|-----|------|-------------|---------------|
| 1 | 010 | 4 | UPDAT | CTL | 3 | | | 0333 | R 337 | |
| 1 | 020 | 4 | RC | R | RD | | | 0337 | / 080 | |
| 1 | 030 | 4 | | CS | 0080 | | | 0341 | / 001 | |
| 1 | 040 | 1 | | SW | 0001 | | | 0345 | I | READ A CARD |
| 1 | 050 | 8 | | BWZ | INSTR | | B | 0346 | V 394 080 B | R ON 12 PUNCH |
| 1 | 060 | 8 | | B | P | 0080 | | 0354 | D 428 080 | |
| 1 | 070 | 8 | | B | P1 | 0080 | | 0362 | B 652 080 I | |
| 1 | 080 | 8 | | B | P1 | 0080 | | 0370 | B 679 080 3 | |
| 1 | 090 | 8 | | B | P1 | 0080 | | 0378 | B 652 080 4 | |
| 1 | 100 | 8 | | B | P6 | 0080 | | 0386 | B 713 080 6 | |
| 1 | 110 | 8 | INSTR | B | ED | 0080 | | 0394 | B 487 080 E | ON END CARD |
| 1 | 120 | 8 | | B | DT | 0080 | | 0402 | B 492 080 D | ON DATE CARD |
| 1 | 130 | 7 | | B | ERRCR | 0079 | | 0410 | M 849 079 | |
| 1 | 140 | 7 | | LCA | 0080 | 0280 | | 0417 | L 080 280 | |
| 1 | 150 | 4 | | M | RD | | | 0424 | Z 337 | |
| 1 | 160 | 7 | P | LCA | 0080 | 0180 | | 0428 | L 080 180 | |
| 1 | 170 | 7 | | LCA | 0080 | 0280 | | 0435 | L 080 280 | |
| 1 | 180 | 1 | | WP | | | | 0442 | 6 | |
| 1 | 190 | 2 | | SS | | | | 0443 | K 4 | ACTIVE |
| 2 | 010 | 7 | PG | R/L | USAMO | 0074 | | 0445 | V 784 074 K | |
| 2 | 020 | 7 | | MCW | TIME | 0080 | | 0453 | M 837 080 | |
| 2 | 030 | 7 | | LCA | 0080 | 0180 | | 0460 | L 080 180 | |
| 2 | 040 | 1 | | LCA | 0080 | 0280 | | 0467 | L 080 280 | |
| 2 | 050 | 8 | | WP | | | | 0474 | 6 | |
| 2 | 060 | 4 | | B | UN5 | 0065 | | 0475 | R 645 065 | |
| 2 | 070 | 4 | EC | B | CHCK | | | 0483 | B 517 | |
| 2 | 080 | 1 | | H | 0006 | | | 0487 | - 006 | |
| 2 | 090 | 7 | DT | H | | | | 0491 | . | |
| 2 | 100 | 7 | | SW | 0001 | 0006 | | 0492 | . | DATES |
| 2 | 110 | 7 | | LCA | 0005 | THIS | | 0499 | L 005 810 | THIS DATE |
| 2 | 120 | 4 | | LCT | 0010 | NEXT | | 0506 | L 010 823 | |
| 2 | 130 | 7 | CHCK | B | RD | 0062 | | 0513 | B 337 | |
| 2 | 140 | 4 | | SW | 0065 | | | 0517 | . | 065 062 |
| 2 | 150 | 7 | | SW | 0059 | | | 0524 | . | 059 |
| 2 | 160 | 7 | | LCA | 0065 | CRR | - 4 | 0528 | L 065 824 | YK |
| 2 | 170 | 7 | | MCW | 0060 | CRR | - 2 | 0535 | M 060 826 | NO |
| 2 | 180 | 7 | | MCW | 0063 | CRR | | 0542 | M 063 828 | DA |
| 2 | 190 | 4 | | CW | 0065 | 006? | | 0549 | J 065 062 | |
| 3 | 010 | 7 | | LCA | NEXT | DTL | | 0556 | J 059 | |
| 3 | 020 | 7 | | S | CRK | DTL | | 0560 | L 823 833 | |
| 3 | 030 | 8 | | RWZ | RD | DTL | | 0574 | S 828 833 | |
| 3 | 040 | 7 | | LCA | THIS | DTL | K | 0574 | V 337 833 | K ON MINUS |
| | | | | | | | | 0582 | L 818 833 | |

Figure 13 UPDAT SOURCE PROGRAM LISTING

| PG LIN | CT | LAPEL | OP | A DPLRAND | B OPERAND | D | LOC | INSTRUCTION COMMENTS | UPDAT |
|--------|----|-------|-----|-----------|-----------|---|------|-----------------------------|----------------|
| 3 040 | 7 | | S | CRR | DIE | | 0589 | S 828 833 | |
| 3 050 | 8 | | BKZ | NXT | DIE | K | 0596 | V 634 833 K DUE NEXT REPORT | |
| 3 060 | 7 | | MCM | FIVE | 0080 | | 0604 | M 834 080 BEHIND | |
| 3 070 | 7 | | LCA | 0080 | 0180 | | 0611 | L 080 180 | |
| 3 080 | 7 | | LCA | 0080 | 0280 | | 0618 | L 080 280 | |
| 3 090 | 1 | | MP | | | | 0625 | 6 | |
| 3 100 | 8 | | BKZ | USAM5 | 0074 | K | 0626 | V 808 074 K ON MINUS | |
| 3 110 | 7 | NXT | MCM | EIGHT | 0080 | | 0634 | M 835 080 | |
| 3 120 | 4 | | F | PI | | | 0641 | B 652 | |
| 3 130 | 7 | UNS | MCM | SEVEN | 0080 | | 0645 | M 836 080 | |
| 3 140 | 7 | PI | LCA | 0080 | 0180 | | 0652 | L 080 180 | |
| 3 150 | 7 | | LCA | 0080 | 0280 | | 0659 | L 080 280 | |
| 3 160 | 1 | | MP | | | | 0666 | 6 | |
| 3 170 | 8 | | BKZ | U1487 | 0074 | K | 0667 | V 802 074 K ON MINUS | |
| 3 180 | 4 | | B | RD | 0180 | | 0675 | B 337 | |
| 3 190 | 7 | P3 | LCA | 0080 | 0180 | | 0679 | L 080 180 | |
| 3 200 | 7 | | LCA | 0080 | 0280 | | 0686 | L 080 280 | |
| 4 010 | 1 | | MP | | | | 0693 | 6 | |
| 4 020 | 8 | | BKZ | USAM3 | 0074 | K | 0694 | V 790 074 K ON MINUS | |
| 4 030 | 7 | P36 | MCM | FLANK - 6 | 0080 | | 0702 | M 838 080 | |
| 4 040 | 4 | | F | P | | | 0709 | B 428 | |
| 4 050 | 7 | P6 | LCA | 0080 | 0180 | | 0713 | L 080 180 | |
| 4 060 | 7 | | LCA | 0080 | 0280 | | 0720 | L 080 280 | |
| 4 070 | 1 | | MP | | | | 0727 | 6 | |
| 4 080 | 8 | | BKZ | USAM6 | 0074 | K | 0728 | V 796 074 K ON MINUS | |
| 4 090 | 4 | P61 | SK | 0067 | | | 0736 | B 067 | |
| 4 100 | 7 | | LCA | 0073 | 0065 | | 0740 | L 073 065 | |
| 4 110 | 7 | | MCM | FLANK | 0073 | | 0747 | M 844 073 | |
| 4 120 | 8 | | F | P67 | 0057 | | 0754 | B 773 057 ON UNSC | |
| 4 130 | 7 | P675 | C* | 0067 | 0059 | | 0762 | J 067 059 | |
| 4 140 | 4 | | F | P36 | | | 0769 | R 702 | |
| 4 150 | 7 | P67 | MCM | 0065 | 0057 | | 0773 | M 065 057 | |
| 4 160 | 4 | | R | P67E | | | 0780 | B 762 | |
| 4 170 | 1 | USAM0 | MP | | | | 0784 | 6 | USAAMA CARD |
| 4 180 | 5 | | SS | P0 | | 8 | 0785 | K 453 8 | SELECT STACKER |
| 4 190 | 1 | USAM* | MP | | | | 0790 | 6 | USAAMA CARD |
| 4 200 | 5 | | SS | P36 | | 8 | 0791 | K 702 8 | SELECT STACKER |
| 5 010 | 1 | USAM6 | MP | | | | 0796 | 6 | USAAMA CARD |
| 5 020 | 5 | | SS | P61 | | 8 | 0797 | K 736 8 | SELECT STACKER |
| 5 030 | 1 | U1487 | MP | | | | 0802 | 6 | USAAMA CARD |
| 5 040 | 5 | | SS | RD | | 8 | 0803 | K 337 8 | SELECT STACKER |
| 5 050 | 1 | USAM5 | MP | | | | 0808 | 6 | USAAMA CARD |
| 5 060 | 5 | | SS | NXT | | 8 | 0809 | K 634 8 | SELECT STACKER |
| 6 010 | 5 | P15 | DS | * | | | 0818 | | |
| 6 020 | 5 | NEXT | DS | * | | | 0823 | | |
| 6 030 | 5 | CRR | DS | * | | | 0828 | | |
| 6 040 | 5 | DIE | DS | * | | | 0833 | | |
| 6 050 | 1 | FIVE | DCM | * | | | 0834 | 5 | |
| 6 060 | 1 | EIGHT | DCM | * | | | 0835 | 8 | |

Figure 13 Continued)

| PG LIN | CT | LABEL | OP | A OPERAND | B OPERAND | D | LOC | INSTRUCTION COMMENTS | UPDAT |
|--------|----|-------|-----|-----------|-----------|-------|--------|----------------------|-----------|
| 6 070 | 1 | SEVEN | DCW | * | | | 7 0836 | | |
| 6 080 | 1 | NINE | DCW | * | | 9 | 0837 | | |
| 6 090 | 7 | BLANK | CCW | * | | | 0844 | | |
| 6 100 | 5 | ERROR | DCW | * | | ERROR | 0849 | | |
| 6 110 | | | END | UPDAT | | | | | / 333 080 |

98 CARDS

Figure 13 Continued)

This card is placed immediately behind the Binary UPDAT deck, and is the first card used by the UPDAT program. It is the information on this card which enables the program to determine whether or not a given milestone is Behind Schedule, and whether or not it is Due Next Report Period.

These dates may be any calendar dates - they need not follow the normal fixed length report period. This enables CAMERA Reports to be compiled for special purposes, as well as for shorter reporting periods than originally planned for the program.

Updated MLSTN Deck

The MLSTN deck which was produced in the previous month's run included all remaining active milestones. Completed and cancelled milestones were not reproduced, and new scheduled completion dates were punched with this information in columns 59-65. At this point, the cards contain the basic information previously described. The next step is to punch the status information for the current report into those cards on which milestone information was reported. This information is punched as follows:

| <u>Status Code</u> <u>Col 80</u> | <u>Milestone</u> <u>Status</u> | <u>Other Information Punched</u> |
|-------------------------------------|-----------------------------------|--|
| 1 | Cancelled | None |
| 3 | New | All other fields punched. |
| 4 | Completed | Punch actual completion date in columns 67-73 (e. g. , 01-02-3) |
| 5 | Rescheduled | Punch new scheduled completion date in columns 67-73 (e. g. , 12-31-4) |

Any other punching is not legitimate, and will cause errors. All other active milestone cards in the updated MLSTN deck remain unpunched in columns 67-73 and 80. Cards should remain in numerical ID number order. As each card is read into the computer by UPDAT program, column 80 and the current due date (except for Status codes 1 & 4) are tested. Additional cards may then be generated by the program for the CAMERA Report as discussed in the next Section.

END Card

The final input card read by the program after the updated MLSTN deck is an END card which signified that no more processing is required. This END card is simply one with the letter "E" punched in Column 80, and END in columns 2-4. See Figure 11e.

Program Results

Each of the updated MLSTN cards read are reproduced by the program in its entirety. This obviates merging the output deck with the input. Additional cards are punched, based on testing the punching in various columns. These cards are punched as follows:

| <u>Status Code</u> <u>Col. 80</u> | <u>Milestone Status</u> |
|--------------------------------------|---|
| 5 | Milestones Behind Schedule |
| 7 | Unscheduled Milestones |
| 8 | Milestones Due Next Report Period |
| 9 | Active Milestones |
| blank | Active Milestones (new MLSTN deck for succeeding report) |

In addition to returning the input cards, an on-line listing of all cards punched is produced. This permits checking prior to further processing. The desired output consists of three separate and distinct decks of cards, one in each of the three 1401 output stackers. The stackers and their contents are:

(1) Normal Stacker

Milestone cards to be used as input to REPRT program for the CAMERA Report. Each card will contain one of eight status codes in column 80 (i. e., 1, 3, 4, 5, 6, 7, 8, 9)

(2) Stacker #4

Active milestones for next month's report on new MLSTN deck. Column 80 will be blank.

(3) Stacker #8

Milestones to be used for a higher level, condensed CAMERA Report, (e. g. , for the U. S. Army Satellite Communications Agency, USASCA). Cards will contain one of the eight status codes 1, 3, 4, 5, 6, 7, 8, 9.

Program Operating Instructions

Machine Adjustments

- (1) Control panels: none.
- (2) Console Switch Settings - all OFF.
- (3) Tape Unit Requirement - none.
- (4) On-line and Off-line Equipment Requirements
 - a. On-line card reader/punch
 - b. On-line printer

Program Data Set-Up

- (1) Binary UPDAT program deck
- (2) DATE card
- (3) MLSTN deck
- (4) END card

Program Exits or Stops

1. "Error" on print out indicates that a card has been read which contains a 12 zone punch in column 80 of the card field and is neither the date card nor the end card. No output card is punched.
2. End of milestones - (0487)

REPRT Program Description⁶

General Information

This program produces a complete CAMERA Report.

The report produced is essentially a print-out of the milestone cards as they are read into the computer. The milestones first must have been categorized according to the order in which they are to appear on the report.

At the beginning of every new page, the major titles are printed, followed by the header cards. Next, the detailed milestone cards themselves are printed in the same order of input. Separate indices are used to count the number of printed lines to a page and the number of pages of the report. After eighteen lines have been printed (maximum number of lines for double spacing), the number of the page is printed, a new page is begun, and the print-out of milestones continues. All header cards actuate the printer to begin a new page.

Input Preparation

Binary REPRT Deck

This is the machine language object program resulting from the compilation of the source program as written by the programmer. A complete listing of the source program is shown in Figure 14.

6. "Management Report", Mildred E. Francis, Booz-Allen Applied Research, Inc., August 13, 1962.

| PG | LN | CT | LA | OP | A | D | B | OP | A | OP | D | LOC | INSTRUCTION | COMMENTS | MANAGE |
|----|-----|----|--------|-----|-----------|---|-----------|----|---|----|---|------|-------------|-------------|-----------------|
| 2 | 200 | 1 | WRITE | X | | | | | | | | 0527 | 2 | WRITE | TAB HEAD |
| 2 | 201 | 4 | | CS | 0299 | | | | | | | 0528 | / | 299 | |
| 2 | 202 | 1 | | W | | | | | | | | 0532 | Z | SKIP A LINE | |
| 3 | 010 | 7 | AA | A | ONE | | CARD | | | | 1 | 0533 | A | S20 S30 | |
| 3 | 050 | 8 | | B | PUS | | 0075 | | | | 2 | 0540 | R | /78 075 1 | |
| 3 | 070 | 8 | | B | USAF | | 0075 | | | | 2 | 0548 | R | /89 075 2 | |
| 3 | 080 | 1 | | B | USAS | | 0075 | | | | 3 | 0556 | B | S00 075 3 | |
| 3 | 090 | 1 | | MCA | | | DETAIL | | | | | 0564 | N | | NASA AGENCY |
| 3 | 095 | 4 | HF | MCA | | | DETAIL | | | | | 0565 | M | 047 W40 | |
| 3 | 096 | 7 | | CS | 0299 | | | | | | | 0572 | / | 299 | |
| 3 | 096 | 7 | | SK | DETAIL-78 | | DLTAIL-73 | | | | | 0576 | / | V62 V67 | |
| 3 | 101 | 7 | | MCS | DETAIL-75 | | 0205 | | | | | 0583 | Z | V65 205 | |
| 3 | 102 | 7 | | MCA | DLTAIL-71 | | 0210 | | | | | 0590 | M | V69 210 | |
| 3 | 103 | 7 | | SK | DETAIL-69 | | DLTAIL-29 | | | | | 0597 | / | V71 W11 | |
| 3 | 104 | 7 | | MCA | DETAIL-31 | | 0251 | | | | | 0604 | M | W09 251 | |
| 3 | 105 | 7 | | MCS | DETAIL-23 | | 0260 | | | | | 0611 | Z | W17 260 | |
| 3 | 106 | 7 | | SK | DETAIL-21 | | 0260 | | | | | 0618 | / | W17 W27 | |
| 3 | 107 | 4 | | SK | DETAIL-6 | | 0269 | | | | | 0625 | / | W34 | |
| 3 | 107 | 4 | | MCS | DETAIL-15 | | 0276 | | | | | 0629 | Z | W25 269 | |
| 3 | 109 | 7 | | MCS | DETAIL-7 | | 0276 | | | | | 0636 | Z | W33 278 | |
| 3 | 110 | 7 | | MCA | DETAIL | | 0287 | | | | | 0643 | M | W40 287 | |
| 3 | 111 | 8 | CHECK | MCA | USARMA | | 0074 | | | | | 0650 | B | /60 074 | |
| 3 | 112 | 1 | CAT | | | | | | | | | 0658 | Z | | |
| 3 | 113 | 4 | | SK | DETAIL-79 | | | | | | | 0659 | / | V61 | |
| 3 | 114 | 4 | | CS | DETAIL | | | | | | | 0663 | / | W40 | |
| 3 | 125 | 4 | | CS | 0299 | | | | | | | 0667 | / | 299 | |
| 3 | 130 | 7 | | M | | | | | | | | 0671 | Z | | CLEAR PRINTER |
| 3 | 140 | 7 | | A | ONE | | CARD | | | | | 0672 | A | S20 S30 | SKIP A LINE |
| 3 | 140 | 7 | | B | CARD | | DLWHITE | | | | | 0679 | C | S30 S22 | TRCKL CARD NO. |
| 3 | 150 | 5 | | B | RD | | | | | | | 0686 | R | 373 / | CARD NO EQUAL 1 |
| 3 | 160 | 7 | | MCA | ZURU | | CARD | | | | | 0691 | M | Y85 S30 | NOT EQUAL |
| 3 | 165 | 2 | | CC | | | | | | | | 0698 | F | - | CLEAR CARD NO |
| 3 | 170 | 4 | | CS | 0299 | | | | | | | 0700 | / | 299 | IMMED SKIP TO C |
| 3 | 175 | 4 | | C | USMC - 1 | | | | | | | 0704 | / | S25 | CLEAR PRINTER |
| 3 | 180 | 7 | | LCA | P540 | | 0251 | | | | | 0705 | L | S26 251 | PAGL NO |
| 3 | 185 | 4 | | SK | TITLE7-17 | | 0251 | | | | | 0715 | / | T37 | |
| 3 | 190 | 7 | | LCA | TITLE7 | | 0259 | | | | | 0719 | L | 149 289 | CONFIDENTIAL |
| 3 | 200 | 1 | | M | | | | | | | | 0726 | Z | | WRITE |
| 3 | 201 | 4 | | SK | P540 - 1 | | | | | | | 0727 | / | S25 | |
| 4 | 010 | 7 | | A | CVE | | P540 | | | | | 0731 | A | S20 S26 | INCRE PG NO |
| 4 | 015 | 2 | | CC | | | | | | | | 0738 | F | 1 | IMMED SKIP TO C |
| 4 | 020 | 4 | | B | RD | | | | | | | 0740 | E | 373 | |
| 4 | 028 | 7 | SUPI | C | ONE | | | | | | | 0744 | C | S20 S28 | |
| 4 | 030 | 5 | | H | SUB2 | | | | | | | 0751 | E | 808 / | |
| 4 | 030 | 4 | | CS | 0299 | | | | | | | 0756 | / | 299 | |
| 4 | 040 | 4 | | SK | TITLE5-79 | | | | | | | 0760 | / | U01 | |
| 4 | 120 | 7 | | LCA | TITLE5-2 | | 0278 | | | | | 0764 | L | 078 278 | |
| 4 | 130 | 4 | | P | WRITE | | | | | | | 0771 | P | 527 | |
| 4 | 131 | 7 | COVERS | MCA | 0078 | | TITLE8-2 | | | | | 0775 | P | 076 X18 | |

Figure 14 (Continued)

| PG | REF | CT | LA | OP | A OPERAND | B OPERAND | D | LOC | INSTRUCTION COMMENTS | MANGL |
|----|-----|----|----------|------|------------|------------|---|------|----------------------|--------------------|
| 4 | 132 | 4 | | R | RD | | | 0782 | B 373 | |
| 4 | 140 | 7 | CCNTR1 | MCW | 0078 | TITLE5- 2 | | 0786 | M 078 U78 | |
| 4 | 150 | 4 | | B | RD | | | 0793 | B 373 | |
| 4 | 160 | 7 | CCNTR2 | MCW | 0078 | TITLE6- 2 | | 0797 | M 078 V58 | |
| 4 | 170 | 4 | | R | RD | | | 0804 | B 373 | |
| 4 | 171 | 4 | SLP2 | CS | 0299 | | | 0808 | / 299 | |
| 4 | 172 | 4 | | MC | TITLE8- 79 | | | 0812 | W41 | |
| 4 | 173 | 7 | LCA | LCA | TITLEB- 2 | 0278 | | 0816 | L X18 278 | |
| 4 | 174 | 4 | | R | WRITE1 | | | 0823 | B 527 | |
| 4 | 180 | 7 | BUSH | DCW | * | | | 0833 | | |
| 4 | 190 | 7 | USAF | DCW | * | BUSHTPS | | 0840 | | |
| 4 | 195 | 7 | N | DCW | * | USAFSSD | | 0847 | | |
| 4 | 200 | 7 | USAFS | DCW | * | NASA | | 0854 | | |
| 5 | 010 | 8 | ST | R | NAVY | | 1 | 0855 | B 928 079 1 | RIT IN 12 /DML |
| 5 | 020 | 8 | | R | COMP | 0079 | 2 | 0863 | B 929 079 2 | |
| 5 | 030 | 8 | | R | PURCH | 0079 | 3 | 0871 | B 957 079 3 | |
| 5 | 040 | 8 | | R | MILLS1 | 0079 | 4 | 0879 | B 968 079 4 | |
| 5 | 050 | 8 | | R | CONTR1 | 0079 | 5 | 0887 | B 786 079 5 | |
| 5 | 060 | 8 | | R | CONTR2 | 0079 | 6 | 0895 | B 797 079 6 | |
| 5 | 065 | 8 | | R | CONTRB | 0079 | 8 | 0903 | B 775 079 8 | |
| 5 | 070 | 7 | | PCW | ERRR | 0079 | | 0911 | M 516 079 | |
| 5 | 080 | 7 | LCA | 0080 | | 02F0 | | 0918 | L 080 280 | ERRR HALL |
| 5 | 090 | 1 | | R | | | | 0925 | 2 | |
| 5 | 100 | 1 | | R | | | | 0926 | * | |
| 5 | 110 | 1 | NAVY | MCW | 0046 | TITLE1 | | 0927 | N | |
| 5 | 120 | 7 | | R | RD | | | 0928 | M 046 579 | |
| 5 | 130 | 4 | | R | RD | | | 0935 | B 373 | |
| 5 | 140 | 7 | CCN1 | PCW | 0013 | TITLE2- 45 | | 0939 | M 013 591 | CONFIDENTIAL TOP |
| 5 | 150 | 4 | | PCW | 0013 | TITLE7 | | 0946 | M 013 149 | CONFIDENTIAL BOT |
| 5 | 160 | 4 | | R | RD | | | 0953 | B 373 | |
| 5 | 170 | 7 | PLANS AC | PCW | 0016 | TITLE2 | | 0957 | M 016 T36 | BUREAU OF SHIPS |
| 5 | 180 | 4 | | R | RD | | | 0964 | B 373 | |
| 5 | 190 | 7 | MILLS1 | PCW | 0051 | TITLE4 | | 0968 | M 051 000 | MILLSTONE DATE |
| 5 | 200 | 4 | | R | RD | | | 0975 | B 373 | |
| 5 | 201 | 7 | BLAL | C | CARD | /FRF | | 0979 | C 530 Y85 | |
| 5 | 202 | 5 | | R | PRINT | | / | 0986 | B 307 / | NOT EQUAL |
| 6 | 010 | 8 | DEADI | R | MCW | 0080 | L | 0991 | B 471 080 | L NLM MILLSTONE |
| 6 | 015 | 8 | | R | MCW | 0080 | J | 0999 | B 471 080 | J CANCELLED |
| 6 | 020 | 8 | | R | UNSCHE | 0080 | M | 1007 | F 433 080 | M COMPLETED MILLS |
| 6 | 030 | 8 | | R | MCW | 0080 | N | 1015 | F 471 080 | N BLIND SCHEDULE |
| 6 | 040 | 8 | | R | UNSCHE | 0080 | U | 1023 | B 702 060 | U RESCHEDULE MILLS |
| 6 | 050 | 8 | | R | UNSCHE | 0080 | P | 1031 | B 733 080 | P UNSCHEDULE MILLS |
| 6 | 060 | 8 | | R | MCW | 0080 | Q | 1039 | B 471 080 | Q DUE NEXT PERIOD |
| 6 | 070 | 8 | | R | MCW | 0080 | K | 1047 | B 471 080 | K ACTIVE MILLSTONE |
| 6 | 080 | 7 | | MCW | ZONE | 0079 | | 1055 | M 404 079 | |
| 6 | 100 | 7 | | LCA | 0080 | 02F0 | | 1062 | I 010 280 | |
| 6 | 110 | 1 | | R | | | | 1069 | / | |
| 6 | 120 | 1 | | R | | | | 1070 | * | ERRR ON /DML |
| 6 | 130 | 7 | PLA | MCW | 0079 | IN ALRGG | | 1071 | N 079 Y85 | MOVE HEADERS |

Figure 14 Continued)

| PG | LN | CT | Label | OP | A OPERAND | B OPERAND | D | LOC | INSTRUCTION COMPLAINTS | RANGE |
|----|-----|----|---------|------|-----------|-----------|-------|------|------------------------------|------------------|
| 6 | 14C | 4 | | S* | K | | | 1078 | * S27 | |
| 6 | 150 | 7 | | ZER0 | ZER0 | | | 1082 | M Y85 S28 | |
| 6 | 160 | 7 | | ZERC | ZERC | | | 1089 | M Y85 S30 | |
| 6 | 165 | 2 | | CC | | | 1 | 1096 | F I | SKIP TO NEW PAGE |
| 6 | 170 | 4 | | H | RD | | | 1098 | 6 373 | |
| 6 | 180 | 7 | RESCRE | MCK | 0079 | | | 1102 | M 079 Y83 | MOVE HEADING |
| 6 | 190 | 4 | | S* | K | | | 1109 | * S27 | |
| 6 | 200 | 7 | | MCK | FOUR | | | 1111 | M S18 S28 | |
| 7 | 010 | 7 | | MCK | ZER0 | | | 1120 | M Y85 S30 | |
| 7 | 025 | 2 | | CC | | | 1 | 1127 | F I | SKIP TO NEW PAGE |
| 7 | 030 | 4 | | H | RD | | | 1129 | B 373 | |
| 7 | 040 | 7 | UNSCRE | MCK | 0079 | | | 1133 | M 079 Y83 | MOVE HEADING |
| 7 | 050 | 7 | | MCK | ZER0 | | | 1140 | M Y85 S30 | CLLAR CARD NO |
| 7 | 060 | 7 | | MCK | DNE | | | 1147 | M S20 S28 | |
| 7 | 065 | 2 | | CC | | | 1 | 1154 | F I | |
| 7 | 070 | 4 | | H | RD | | | 1156 | B 373 | |
| 7 | 110 | 7 | USAAMA | MN | ASTER | 0201 | | 1160 | D S31 201 | |
| 7 | 120 | 7 | | MZ | ASTER | 0201 | | 1167 | Y S31 201 | |
| 7 | 130 | 4 | | B | CAT | | | 1174 | B 658 W40 | |
| 7 | 140 | 7 | BLS | MCK | EUSH | DETAIL | | 1178 | M 833 W40 | |
| 7 | 150 | 4 | | R | RR | | | 1185 | B 572 | |
| 7 | 160 | 7 | USAF | MCK | USAF | DETAIL | | 1189 | M 840 W40 | |
| 7 | 170 | 4 | | H | RB | | | 1196 | B 572 | |
| 7 | 180 | 7 | USAS | MCK | USAFS | DETAIL | | 1200 | M 854 W40 | |
| 7 | 190 | 4 | | B | BB | | | 1207 | B 572 | |
| 7 | 200 | 1 | | NOP | | | | 1211 | N | |
| 8 | 010 | 5 | ERR0R | DCM | * | | ERROR | 1216 | | |
| 8 | 020 | 2 | FCLR | DCM | * | | 04 | 1218 | | |
| 8 | 030 | 2 | GNE | DCM | * | | 01 | 1220 | | |
| 8 | 040 | 2 | EIGHTE | DCM | * | | 18 | 1222 | | |
| 8 | 050 | 4 | PGND | DCM | * | | A- | 1226 | | |
| 8 | 060 | 2 | K | DS | * | | | 1228 | | |
| 8 | 070 | 2 | CARD | DCM | * | | | 1230 | | |
| 8 | 080 | 1 | ASTER | DCM | * | | * | 1231 | | |
| 8 | 090 | 2 | SIX | DCM | * | | 06 | 1233 | | |
| 8 | 100 | 46 | TTLB1 | DS | * | | | 1279 | | |
| 8 | 110 | 57 | TTLB2 | DS | * | | | 1336 | | |
| 8 | 120 | 13 | TTLB7 | DS | * | | | 1349 | | |
| 8 | 130 | 51 | TTLB4 | DS | * | | | 1400 | | |
| 8 | 140 | 80 | TTLB5 | DS | * | | | 1480 | | |
| 8 | 140 | 80 | TTLB6 | DS | * | | | 1560 | | |
| 8 | 150 | 80 | DETAIL | DS | * | | | 1640 | | |
| 8 | 160 | 80 | TTLB9 | DS | * | | | 1720 | | |
| 8 | 165 | 30 | TTLB9 | DS | * | | | 1800 | | |
| 8 | 170 | 4 | ZCNE | DC* | | | ZUNE | 1804 | | |
| 8 | 180 | 75 | HEADING | DS | * | | | 1883 | | |
| 8 | 190 | 2 | ZER0 | DCM | * | | | 1885 | | |
| 9 | 010 | 2 | TTLB | R | SUBDUE | 0080 | H | 1894 | B Z14 080 H SURSY DUE NXT PD | |
| 9 | 020 | 2 | | B | SUBDUE | 0080 | I | 1894 | B Z14 080 I SURSY ACTIVE MLS | |

Figure 14 Continued)

| PG | LINE | CT | LABELED | OP | A OPERAND | B OPERAND | D | LOC | INSTRUCTION | COMMENTS | RANGE |
|----|------|----|---------|-----|------------|-----------|---|------|-------------|------------------|-------|
| 9 | 025 | 8 | | B | FINIS | 0080 | E | 1902 | R J50 080 E | | |
| 9 | 026 | 4 | | B | S7 | | | 1910 | B 855 | | |
| 9 | 027 | 7 | SLDDBE | C | ZERO | CARD | S | 1914 | C Y85 S30 | CARD EQUAL ZERO | |
| 9 | 028 | 5 | | B | SURDUI | | | 1921 | B Z73 S | BRANCH IF LAKUL | |
| 9 | 030 | 2 | | CC | | | - | 1926 | F - | SKIP END OF PAGE | |
| 9 | 031 | 4 | | CS | 0299 | | | 1928 | / 299 | CLEAR PRINTER | |
| 9 | 032 | 4 | | CA | PSNG - 1 | | | 1932 | J S25 | | |
| 9 | 033 | 7 | | LCA | PGND | 0251 | | 1936 | L S26 251 | | |
| 9 | 034 | 4 | | SW | TITLE7- 12 | | | 1943 | T 37 | | |
| 9 | 035 | 7 | | LCA | TITLE7 | 0287 | | 1947 | L T49 287 | PG NU AND CONF | |
| 9 | 036 | 1 | | M | | | | 1954 | Z | | |
| 9 | 037 | 4 | | S* | PGND - 1 | | | 1955 | S 25 | | |
| 9 | 038 | 7 | | A | ONE | PGND | | 1957 | A S20 S26 | INCRL PAGL NO | |
| 9 | 039 | 7 | | CA | ZERO | CARD | | 1966 | M Y85 S30 | | |
| 9 | 040 | 2 | | CC | | | 1 | 1973 | F 1 | SKIP TO NEW PAGE | |
| 9 | 041 | 4 | SLDDBE | CS | 0299 | | | 1975 | / 299 | | |
| 9 | 042 | 4 | | S* | TITLE1- 45 | | | 1979 | S34 | | |
| 9 | 043 | 7 | | LCA | TITLE1 | 0272 | | 1983 | L S79 272 | | |
| 9 | 044 | 1 | | A | | | | 1990 | Z | | |
| 9 | 045 | 4 | | CS | 0299 | | | 1991 | / 299 | PRINT TITLE | |
| 9 | 046 | 1 | | K | | | | 1995 | Z | CLEAR PRINTERE1 | |
| 9 | 047 | 4 | | S* | TITLE2- 54 | | | 1996 | S 80 | | |
| 9 | 048 | 4 | | CA | TITLE2- 14 | | | 2000 | T 22 | | |
| 9 | 049 | 7 | | LCA | TITLE2 | 0257 | | 2004 | L T36 257 | | |
| 9 | 050 | 1 | | A | | | | 2011 | Z | | |
| 9 | 051 | 4 | | CS | 0299 | | | 2012 | / 299 | | |
| 9 | 052 | 1 | | K | | | | 2016 | Z | | |
| 9 | 053 | 4 | | S* | TITLE4- 50 | | | 2017 | T 50 | | |
| 9 | 054 | 7 | | LCA | TITLE4 | 0276 | | 2021 | L U00 276 | | |
| 9 | 055 | 1 | | A | | | | 2028 | Z | | |
| 9 | 056 | 4 | | CS | 0299 | | | 2029 | / 299 | | |
| 9 | 057 | 1 | | M | HEADN* | 0279 | | 2033 | Z | | |
| 9 | 058 | 7 | | LCA | | | | 2034 | L Y83 279 | | |
| 9 | 059 | 1 | | A | | | | 2041 | Z | | |
| 9 | 060 | 4 | | CS | 0299 | | | 2042 | / 299 | | |
| 9 | 061 | 1 | | A | | | | 2046 | Z | | |
| 9 | 062 | 4 | | S* | TITLE6- 79 | | | 2047 | T U81 | | |
| 9 | 063 | 7 | | LCA | TITLE6- 7 | 0278 | | 2051 | L V58 278 | | |
| 9 | 064 | 1 | | A | | | | 2058 | Z | | |
| 9 | 065 | 4 | | CS | 0299 | | | 2059 | / 299 | | |
| 10 | 089 | 1 | | M | | | | 2063 | Z | SKIP LINE | |
| 10 | 090 | 7 | | LCA | 0079 | 0280 | 1 | 2064 | L 079 280 | SUBHEADING | |
| 10 | 100 | 1 | | A | | | | 2071 | Z | | |
| 10 | 101 | 4 | | CS | 0299 | | | 2072 | / 299 | | |
| 10 | 102 | 1 | | A | | | | 2076 | Z | | |
| 10 | 103 | 7 | | S* | ZEROC | CARD | | 2077 | T Y85 S30 | | |
| 10 | 104 | 7 | | S* | SIX | CARD | | 2084 | A S33 S30 | | |
| 10 | 105 | 4 | | CS | CORO | | | 2091 | / 060 | | |
| 10 | 106 | 7 | | S* | C001 | 0201 | | 2095 | T 001 201 | | |

Figure 14 (Continued)

| PG | LN | CT | LABEL | OP | A OPERAND | R OPERAND | D | LOC | INSTRUCTION COMMENTS | RANGE |
|----|-----|----|--------|-----|------------|-----------|---|------|----------------------------|----------------|
| 10 | 120 | 1 | | R | S6 | | | 2102 | I | |
| 10 | 130 | 4 | | B | | | | 2103 | B 402 | READ A CARD |
| 10 | 131 | 4 | PRINT | CS | 0299 | | | 2107 | / 299 | CLEAR PRINTER |
| 10 | 132 | 4 | | CW | PGND - 1 | | | 2111 | / S25 | |
| 10 | 133 | 7 | | LCA | PGND - 1 | 0251 | | 2115 | L S26 251 | |
| 10 | 134 | 4 | | SW | TITLE7- 12 | | | 2122 | / 137 | |
| 10 | 135 | 7 | | LCA | TITLE7 | 0289 | | 2126 | L 149 289 | |
| 10 | 136 | 2 | | CC | | | | 2133 | F - | |
| 10 | 137 | 4 | | S* | PGND - 1 | | | 2135 | / S25 | |
| 10 | 138 | 7 | | A | ONE | PGND | | 2139 | A S20 S26 | |
| 10 | 139 | 4 | | M | HEAD1 | | | 2146 | 2 991 | |
| 10 | 140 | 2 | FINIS | CC | | | | 2150 | F - | |
| 10 | 150 | 4 | | CS | 0299 | | | 2152 | / 299 | |
| 10 | 160 | 4 | | CW | PGND - 1 | | | 2156 | / S25 | |
| 10 | 170 | 7 | | LCA | PGND - 1 | 0251 | | 2160 | L S26 251 | |
| 10 | 180 | 4 | | S* | TITLE7- 12 | | | 2167 | / 137 | |
| 10 | 190 | 7 | | LCA | TITLE7 | 0289 | | 2171 | L 149 289 | |
| 10 | 200 | 1 | | M | | | | 2178 | 2 | |
| 11 | 010 | 4 | | SK | PGND - 1 | | | 2179 | / S25 | |
| 11 | 020 | 7 | | A | CHE | PGND | | 2183 | A S20 S26 | |
| 11 | 030 | 2 | | CC | | | 1 | 2190 | F 1 | NEW PAGE |
| 11 | 040 | 7 | | MCW | ZERO | CARD | | 2192 | M Y85 S30 | ZERO INTD CARD |
| 11 | 050 | 7 | AGAIN | SK | 0001 | 0201 | | 2199 | / 001 201 | SET WORD MARKS |
| 11 | 060 | 1 | | R | | | B | 2206 | 1 | READ A CAR 0 |
| 11 | 070 | 8 | | BKZ | JCAN | 0080 | | 2207 | V K63 080 R 12 ZONE IN 80 | |
| 11 | 080 | 7 | | C | CARD | ZERO | | 2215 | C S30 Y85 | |
| 11 | 090 | 5 | | B | NEWPGN | | S | 2222 | B K82 S | CARD = 0 |
| 11 | 100 | 7 | | LCA | COUO | 0280 | | 2227 | L 080 280 | |
| 11 | 110 | 1 | | M | | | | 2234 | 2 | |
| 11 | 120 | 4 | | CS | 0299 | | | 2235 | / 299 | |
| 11 | 130 | 1 | | M | | | | 2239 | 2 | |
| 11 | 140 | 7 | | A | ONE | CARD | | 2240 | A S20 S30 | |
| 11 | 150 | 7 | | C | CARD | EIGHTE | | 2247 | C S30 S22 | |
| 11 | 160 | 5 | | B | FINIS | | S | 2254 | B J50 S | CARD = 18 |
| 11 | 170 | 4 | | B | AGAIN | | | 2259 | B J99 | |
| 11 | 180 | 8 | JCAN | R | ATLAST | 0080 | E | 2263 | F L33 080 E END OF PROGRAM | |
| 11 | 190 | 7 | | MCW | 0080 | TITLE9 | | 2271 | M 080 Y00 | |
| 11 | 200 | 4 | | B | AGAIN | | | 2278 | B J99 | |
| 12 | 010 | 4 | | CS | 0299 | | | 2282 | / 299 | |
| 12 | 020 | 4 | NEWPGN | SV | TITLE9- 79 | | | 2286 | / X21 | |
| 12 | 030 | 7 | | LCA | TITLE9- 1 | 0280 | | 2290 | L X99 280 | |
| 12 | 040 | 1 | | M | | | | 2297 | 2 | |
| 12 | 050 | 7 | | A | ONE | CARD | | 2298 | A S20 S30 | |
| 12 | 060 | 4 | | CS | 0299 | | | 2305 | / 299 | |
| 12 | 070 | 1 | | M | | | | 2309 | 2 | |
| 12 | 080 | 7 | | LCA | 0030 | 0280 | | 2310 | L 080 280 | |
| 12 | 090 | 1 | | M | | | | 2317 | 2 | |
| 12 | 100 | 7 | | A | ONE | CARD | | 2318 | A S20 S30 | |
| 12 | 110 | 4 | | CS | 0299 | | | 2325 | / 299 | |

Figure 14 Continued)

| PG | LN | CT | LABEL | DP | A OPERAND | B OPERAND | D | LDC | INSTRUCTION | COMMENTS | RANGE |
|----|-----|----|--------|-----|------------|-----------|---|------|-------------|-------------|-------|
| 12 | 120 | 4 | | M | ACATN | | | 2329 | Z J99 | | |
| 12 | 130 | 2 | ATLAST | CC | | | | 2333 | F - | END OF PAGE | |
| 12 | 140 | 4 | | CS | 029* | | | 2335 | / 299 | | |
| 12 | 150 | 4 | | CA | PGNC - 1 | | | 2339 |) S25 | | |
| 12 | 160 | 7 | | LCA | PGNC | 0251 | | 2343 | L S26 251 | | |
| 12 | 165 | 4 | | SP | TITLE7- 12 | | | 2350 | * T37 289 | | |
| 12 | 170 | 7 | | LCA | TITLE7 : | 0289 | | 2354 | L T49 289 | | |
| 12 | 180 | 1 | | M | | | | 2361 | 2 | | |
| 12 | 185 | 1 | | H | | | | 2362 | * | | |
| 12 | 190 | 1 | | RCP | BEGIN | | | 2363 | N / 333 080 | | |
| 12 | 200 | 1 | | END | | | | | | | |

300 CARDS

Figure 14 Continued)

TITLE Deck

These cards determine the first few lines of printing on each page.

DATA Deck

This is the deck of milestone cards which forms the body of the report. These were produced by the UPDAT program, and arranged manually for the REPRT program.

END Card

This card will denote the end of milestone cards to the REPRT program. It is simply a card with the letter "E" punched in Column 80.

ABBR Deck

A card deck of abbreviations of contractors and agencies used. Use of this deck is optional.

END Card

This card will denote the final end of the input data. It is a card punched with "END" in Columns 2-4, and an "E" in Column 80.

Program Results

Figure 15 is a detailed flow chart of the operation of the program. As each milestone is arranged in storage for printing, certain card columns are tested. For example, Column 74 of each milestone card is checked to determine if the milestone is to be reported on a separate CAMERA Report to higher authority (e. g. , USASCA). All such milestones are indicated by an asterisk on the report. Column 75 of the milestone card field is checked to determine the action agency of the milestone. If an action agency does exist, the name of the agency is shown in the print-out.

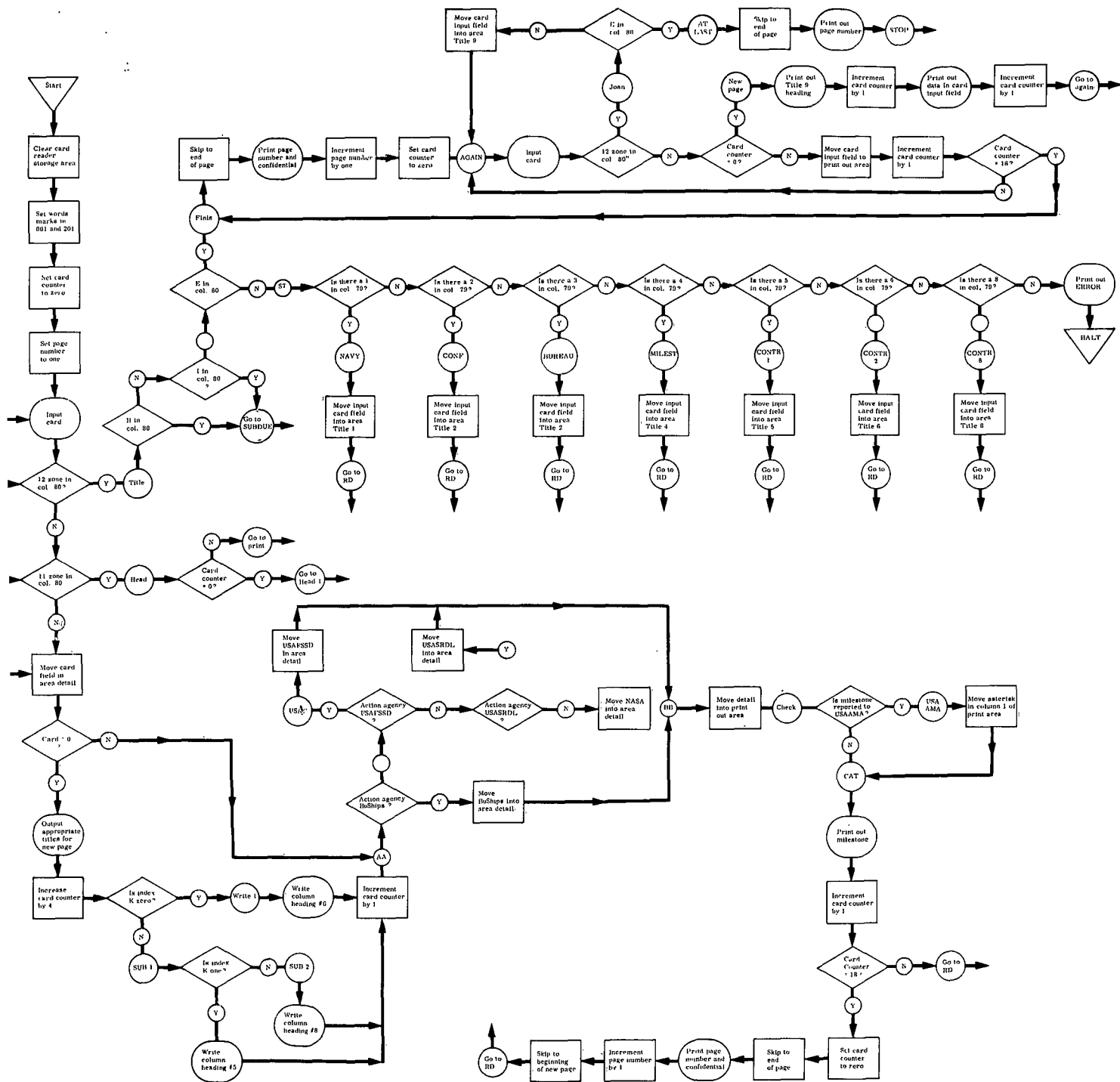

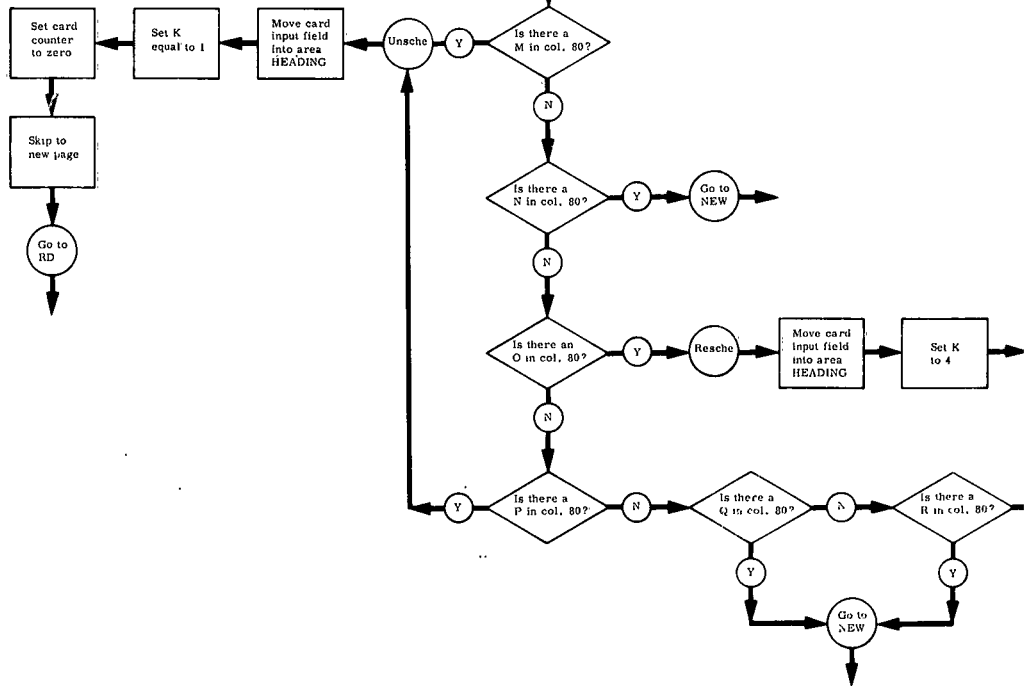
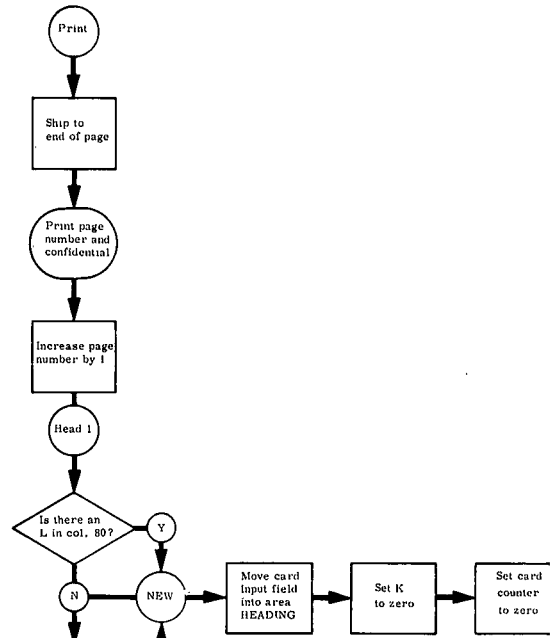
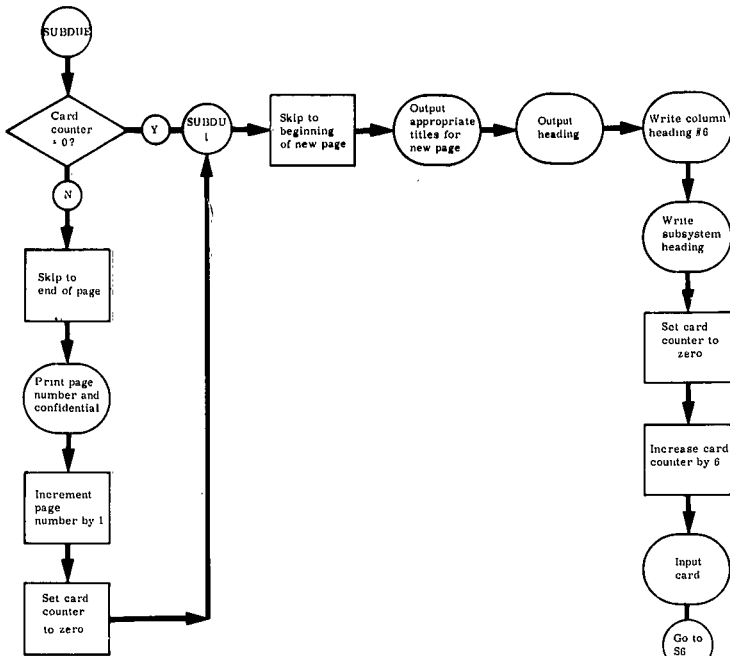

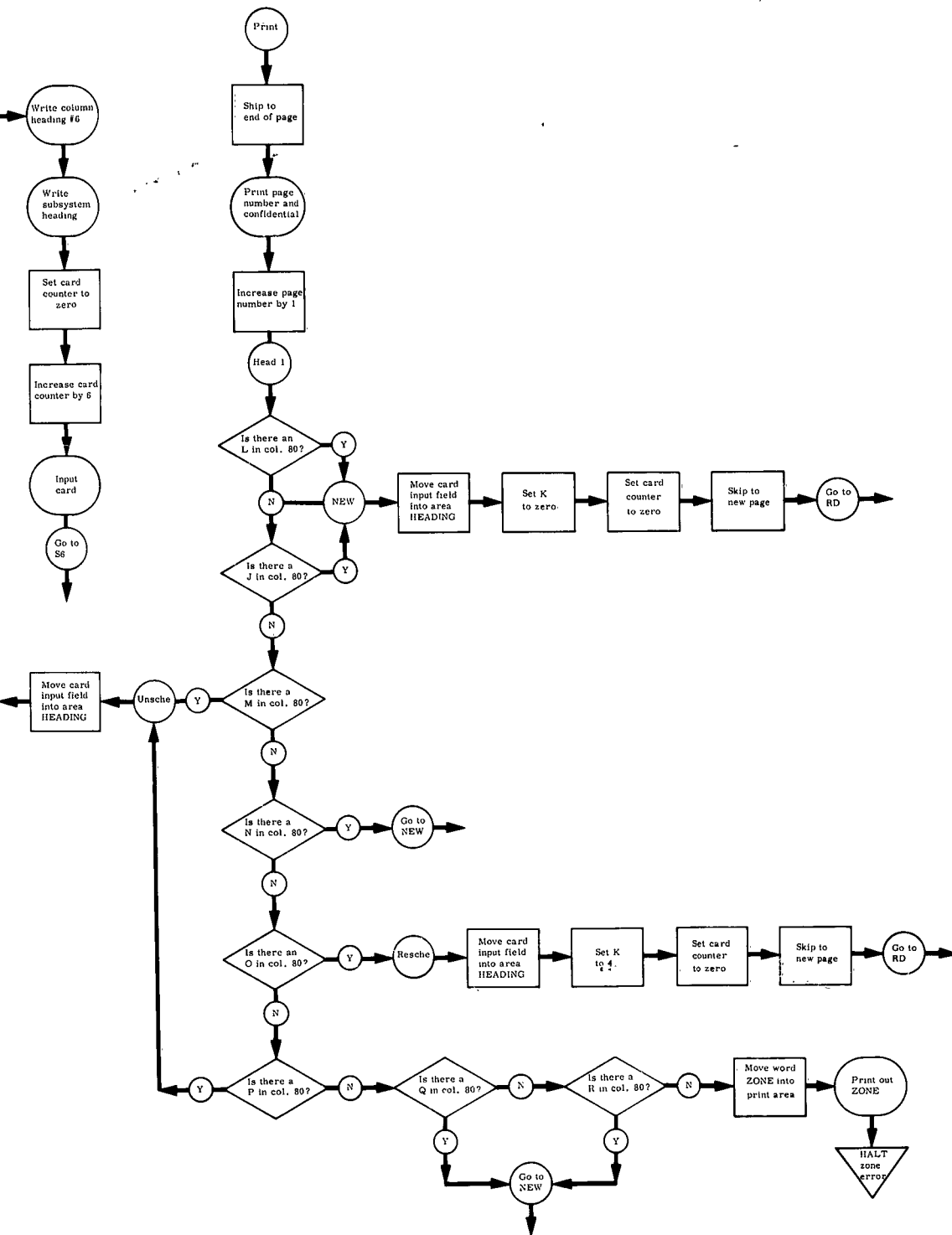

-61- Figure 15 (continued)

Program Operating Instructions

Machine Adjustment

- (1) Control Panels - none
- (2) Console Switch Settings - ALL OFF
- (3) Tape Unit Preparation - none
- (4) On-Line and Off-Line Equipment Requirements
 - a. On-Line Card Reader
 - b. On-Line Printer
 - . 8-1/2 x 11 paper
 - . Control carriage tape with punch in channel 12 to indicate the end of a page and a punch in channel 1 to indicate the beginning of a page.

Program Data Set-Up

- (1) Binary REPRT Program Deck
- (2) TITLE Deck
- (3) DATA Deck
- (4) END card to indicate end of milestone deck
- (5) ABBR Deck
- (6) END card to indicate end of all cards to be processed.

Program Stops

- (1) Illegal character in column 79 of title card
 - . Prints error
 - . Halts at loc. 0926
- (2) Illegal character in column 80 of subheading card
 - . Prints zone
 - . Halts at loc. 1070
- (3) End of program - loc. 2363.

DISTRIBUTION

Code 360A
Bureau of Ships
Department of the Navy
Washington, D. C.

Code 606
Bureau of Ships
Department of the Navy
Washington, D. C.

Office of Technical Services
Department of Commerce
Attn: Acquisition Section
Washington, D. C.

Communications Satellite Program Office
Defense Communications Agency
Washington, D. C.

United States Army Satellite Communications Agency
Fort Monmouth, New Jersey

Defense Documentation Center Headquarters
Building 5, Cameron Station
Alexandria, Virginia