

**UNCLASSIFIED**

**AD 409 562 \_**

**DEFENSE DOCUMENTATION CENTER**

**FOR**

**SCIENTIFIC AND TECHNICAL INFORMATION**

**CAMERON STATION, ALEXANDRIA, VIRGINIA**



**UNCLASSIFIED**

NOTICE: When government or other drawings, specifications or other data are used for any purpose other than in connection with a definitely related government procurement operation, the U. S. Government thereby incurs no responsibility, nor any obligation whatsoever; and the fact that the Government may have formulated, furnished, or in any way supplied the said drawings, specifications, or other data is not to be regarded by implication or otherwise as in any manner licensing the holder or any other person or corporation, or conveying any rights or permission to manufacture, use or sell any patented invention that may in any way be related thereto.

63. 4-2

INDEXED BY 2-6  
AS AD No. 409562

FTD-TT 63-423

# TRANSLATION

DEVICE FOR MEASURING TEMPERATURE COEFFICIENTS  
OF SMALL MAGNETS

By

V. N. Bobrov

## FOREIGN TECHNOLOGY DIVISION

AIR FORCE SYSTEMS COMMAND

WRIGHT-PATTERSON AIR FORCE BASE

OHIO

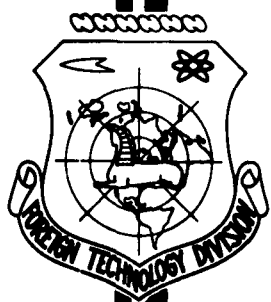

409562

DDC  
RECEIVED  
JUL 6 1963  
JISIA D

## UNEDITED ROUGH DRAFT TRANSLATION

DEVICE FOR MEASURING TEMPERATURE COEFFI-  
CIENTS OF SMALL MAGNETS

BY: V. N. Bobrov

English Pages: 5

SOURCE: Russian Periodical, Geomagnetizm  
i aeronomiya, Izdatel'stvo  
Akademii Nauk SSSR, Vol. II, 1962,  
pp. 550-552.

T-99  
S/203-62-2-3-19-21

THIS TRANSLATION IS A RENDITION OF THE ORIGINAL FOREIGN TEXT WITHOUT ANY ANALYTICAL OR EDITORIAL COMMENT. STATEMENTS OR THEORIES ADVOCATED OR IMPLIED ARE THOSE OF THE SOURCE AND DO NOT NECESSARILY REFLECT THE POSITION OR OPINION OF THE FOREIGN TECHNOLOGY DIVISION.

PREPARED BY:  
TRANSLATION DIVISION  
FOREIGN TECHNOLOGY DIVISION  
WP-APB, OHIO.

DEVICE FOR MEASURING TEMPERATURE COEFFICIENTS OF  
SMALL MAGNETS

V. N. Bobrov

Described here is a device intended for rapid measurement of temperature coefficients of small magnets with temperature coefficients  $\mu \geq 10^{-6}$ .

Owing to the organization at The Institute of Terrestrial Magnetism, Ionosphere, and Propagation of Radio Waves of the Academy of Sciences USSR (IZMIRAN) of the serial production of quartz geomagnetic devices [1], [2] which use small magnets having small temperature coefficients, it has become necessary to develop a device for measuring temperature coefficients  $\mu$  which provide: 1) the possibility of measuring  $\mu$  for magnets with moments  $M < 1$  CGS, 2) the possibility of measuring values of  $\mu \approx 10^{-6}$ , 3) high accuracy and rapid measurements.

The device developed earlier by the author [3] does not satisfy the first two requirements.

A short report is presented below of a new device produced in 1960. Two years of use have shown that the device has high qualities.

The base of the device (Fig. 1) is quartz sensing element 1

enclosed in an air-tight housing 2. A magnet with magnetic moment less than 0.5 CGS is used as the suspension system of the sensing element. The suspension system is adjusted by delicate untwisted threads in a zero magnetic field. The housing with the sensing element is fastened to clamp 3 rigidly secured to base 4 which is made in the form of a flat disk with three adjustment screws. On the clamp below the housing is fastened a rotating rod 5 with magnet 6 which serves to change the scale division of the sensing element. Above the housing is rigidly fastened rod 7 with comagnet 8 which is used if necessary to change the field at the center of the sensing element. Above the clamp is fastened busbar 9. Along it runs carriage 10 with rod 11 at the end of which is the investigated magnet 12.

The scale division of the sensing element is determined by means of rotatable magnet 13 with a known magnetic moment. The deflection angle of the magnet is reckoned by the degree divisions plotted on head 14. If the examined magnet has a larger temperature coefficient, then rotatable magnet 13 is used directly to measure the field produced by the change of temperature of the examined magnet (null method). The readings on the device are taken by an ordinary telescope 15. In a number of cases it is more expedient to remove the telescope and to take the readings by means of an additional scale and illuminator placed at a certain distance from the device. In this case the scale division and the field caused by the temperature change of the examined magnet are determined electrically. For this purpose, on the lateral surface of the housing of the sensing element is one loop of wire 16 with a known constant.

The sensing element is adjusted to a scale division of the order of 1  $\gamma$  per division. With the aid of comagnet 6 the scale division,

when needed, can be reduced to 0.05  $\gamma$  and less.

The temperature coefficient on the described device is measured in the following way. The device stands so that a line, crossing through the center of the suspended magnet and the examined magnet, is situated perpendicular to the magnetic meridian. Then, moving the carriage with the examined magnet, such a position is obtained that the horizontal component H will be compensated at the center of sensing element. After that, the magnet is dipped successively in vessel 17 with cold and hot water and the change in the readings of the device  $\Delta H$  are recorded. The changes  $\Delta H$  are recorded either directly by the telescope scale or by the complementary scale or by the deflection angle of magnet 14 with a null method of reading.

The temperature coefficient  $\mu$  is calculated by the formula:

$$\mu = \frac{\Delta H}{H \Delta t}.$$

where  $\Delta t$  is the temperature difference of the cold and hot water. If the examined magnet has a very small magnetic moment and it is practically impossible for it to compensate the horizontal component H, then in this case comagnet 8 is used which creates at the center of the sensing element the known field  $H_1$ . Then  $\mu$  is calculated by the formula:

$$\mu = \frac{\Delta H}{(H - H_1) \Delta t}.$$

A model of the device produced in IZMIRAN allows adjustment to a scale division up to 0.05 $\gamma$  and permits determination of temperature coefficients up to  $10^{-6}$ . Actually if  $H = 20000\gamma$ ,  $\Delta t = 80^\circ$ ,  $\Delta H = 1.6\gamma$ , then  $\mu = 10^{-6}$ .

The error of determining  $\mu$  will depend on disregarding variations of the horizontal components when reading the device. However, this

error is sufficiently small if we consider that the individual measurement of  $\mu$  on the instrument takes no more than 10 seconds and the calculation of  $\mu$  is the result of averaging certain successively performed determinations. The rate of determination of  $\mu$  (10 sec) is determined by the time during which the small magnet assumes the temperature of the surrounding water.

We can disregard the error of determination of  $\mu$  caused by the linear expansion of busbar 9 since the solid busbar in such a short interval of time does not change its temperature. To ensure this, a heat insulating plate protecting the busbar from heat is attached to carriage 10 below the busbar.

The error of determination of  $\mu$  caused by linear expansion of rod 11 can be estimated in the following way. Let the rod length be 100 mm, and the coefficient of linear expansion of brass be  $2 \cdot 10^{-5}$ . Then upon heating of the rod, the displacement of the magnet will equal 0.1 mm per  $50^\circ$  on the average. If the distance between the examined magnet and the suspended magnet is 50 mm, then the error of determination of  $\mu$  will equal 0.03  $\gamma$ .

The error is calculated by the formula

$$d\Delta H = H \left[ 1 - \frac{R^2}{2R_1^2} (2\cos^2\alpha - \sin^2\alpha) \right],$$

where  $H = 20000 \gamma$ ,  $R = 50 \text{ mm}$ ,

$$R_1 = \sqrt{50^2 + (0,1)^2}, \quad \sin\alpha = 0,002.$$

To increase the accuracy of measuring the temperature coefficients of magnets with  $\mu \approx 10^{-6}$ , it is desirable to make the busbar and rod from quartz, whose coefficient of linear expansion is two orders less than that of brass.

In conclusion the author expresses gratitude to glassblowers

N. D. Kulikov and A. I. Bushuyev for preparing the device.

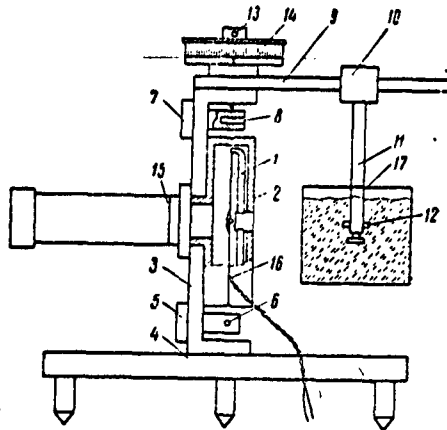

Fig. 1.

#### REFERENCES

1. V. N. Bobrov. Universal'nyy vysokostabil'nyy kvartsevyy chuvstvitel'nyy element s nulevym temperaturnym koeffitsiyentom dlya magnetetrov, variometrov i mikrovariometrov, registriruyushchikh lyubuyu sostavlyayushchuyu zemnogo polyu. Voprosy zemnogo magnetizma. Tr. IZMIRAN, 1961, No. 18 (28), 55.
2. V. N. Bobrov. Seriya kvartsevyykh magnitnykh variometrov. Geomagn. i aeronomiya, 1962, Vol. 2, No. 2, 348.
3. V. N. Bobrov. Pribor dlya opredeleniya magnitnykh momentov i temperaturnykh koeffitsiyentov magnetov. Tr. IZMIRAN, 1960, No. 16 (26), 178.

DISTRIBUTION LIST

DEPARTMENT OF DEFENSE	Nr. Copies	MAJOR AIR COMMANDS	Nr. Copies
		AFSC	
		SCFDD	1
		DDC	25
		TDBTL	5
HEADQUARTERS USAF		TBDBP	2
		TDES (Capt. Smith)	1
AFCIN-3D2	1	AFMTC (MTW)	1
ARL (ARB)	1	AFWL (WLF)	1
		ASD (ASYIM)	2
		ESD (ESY)	1
		RADC (RAY)	1
		SSD (SSF)	2
OTHER AGENCIES			
CIA	1		
NSA	6		
DIA	9		
AID	2		
OTS	2		
AEC	2		
PWS	1		
NASA	1		
ARMY (FSTC)	3		
NAVY	3		
NAFEC	1		
AFCRL (CRCLR)	1		
RAND	1		
PGE	12		