

AD No. 41 0055

DDC FILE COPY

500000

9/

THE DESIGN, TESTING, AND INSTALLATION OF
WS 107A PROPELLANT-LOADING SYSTEMS

PROGRAM PROGRESS
REPORT NO. 14

Contract Number AF 04(0-7)-464

1 January through 31 March 1963

Scale - 2

Prepared for

AIR FORCE BALLISTIC SYSTEMS DIVISION
AIR FORCE SYSTEMS COMMAND

1 APRIL 1963

C-62458

DDC
RECEIVED
JUL 23 1963
TISIA B

M 4.60

410055

A R T H U R D. L I T T L E I N C.

245

④ #5.60 ⑤ 327-200

⑥ 3-5 NA

THE DESIGN, TESTING, AND INSTALLATION OF
WS 107A PROPELLANT-LOADING SYSTEMS,

⑨ PROGRAM PROGRESS,

REPORT NO. 14,

⑮ Contract Number AF 04(647)-464
1 January through 31 March 1963.

⑩ A-A
⑫ [5] P.
⑬ A-A
⑭ ... NA
⑯ U
⑰ A-A

Prepared for

AIR FORCE BALLISTIC SYSTEMS DIVISION
AIR FORCE SYSTEMS COMMAND

⑪ 1 April 1963,

⑭ kept no. C-62458

Arthur D. Little, Inc.





Arthur D. Little, Inc.
SANTA MONICA OPERATIONS

1424 FOURTH STREET
SANTA MONICA, CALIFORNIA
451-1721

1 April 1963

Commander
Air Force Ballistic Systems Division
Air Force Systems Command
Headquarters
Air Force Unit Post Office
Los Angeles 45, California

Attention: TDC

Subject: Transmittal of Progress Report No. 14 on WS 107A
Program, Contract No. AF 04(647)-464

Gentlemen: C-62458

This report summarizes our work from 1 January through 31 March, 1963, on the design, testing, and installation of propellant-loading systems.

Respectfully submitted,

G. A. Bleyle, Jr.
Vice President

HEADQUARTERS - CAMBRIDGE, MASSACHUSETTS

CHICAGO SAN FRANCISCO NEW YORK WASHINGTON SANTA MONICA
TORONTO SAN JUAN MEXICO CITY EDINBURGH ZÜRICH

CONTENTS

	Page
I. SUMMARY	1
II. FIELD TECHNICAL OBSERVATION AND START-UP ACTIVITIES	2
A. Beale Air Force Base	2
III. PROPELLANT-LOADING SYSTEM FOR WS 107A-2	6
A. System Status	6
B. Vandenberg AFB Titan I Activities	7
C. Special Studies	11
IV. VISITS AND CONFERENCES	40
APPENDIX A. ADL CHANGE REQUEST STATUS, WS 107A-2	42
APPENDIX B. THE DEVELOPMENT OF HIGH PERFORMANCE INSULATION SYSTEMS	Under separate cover

ILLUSTRATIONS

Figure		Page
1.	Helium Recovery System and Test Instrumentation	12
2.	Helium Recovery Trailer	14
3.	Thermocouple Data	16
4.	Effect of Flow Rate on Helium Temperature at Recovery Connection	18
5.	Calculated Temperature at Helium Recovery Connection . .	19
6.	Inlet Tube Wall Temperature of Helium Trailer	22
7.	Sketch of Test Apparatus	25
8.	Test Data for 1/2-Inch Bolt	27
9.	Test Data for 5/8-Inch Bolt	28
10.	Test Data for 3/4-Inch Bolt	29
11.	Test Data for 7/8-Inch Bolt	30
12.	Torque as a Function of Yield Load	31
14.	LO ₂ Rapid Load, Stages I and II	33
15.	LO ₂ Fine Load, Stages I and II	34
16.	LO ₂ Topping Lines Stages I and II	35
17.	LO ₂ Unload Stage I	36
18.	LO ₂ Unload Stage II	37

I. SUMMARY

This report reviews our work on the WS 107A-2 Propellant-Loading System for 1 January through 31 March 1963.

Field technical activities were completed at Beale Air Force Base on 31 March 1963. Final work there included technical assistance during the accelerated rebuild program and during I & C at launcher 4C-1.

Solutions to problems with the noise sensitivity of liquid sensors and the differential-pressure gauges for the LO₂ filters were proposed. A procedure for leak-testing the helium system was adopted.

~~At Vandenberg AFB, we were mainly concerned with the completion of the Category II program and our participation in the Operational Verification Program and the Penetration Aids Program. We also conducted a~~ vent-valve cycling exercise in order to evaluate rapid recycling possibilities and compiled temperature data for the helium recovery system *was also conducted.*

The liquid sensor program is approaching completion and the final report is expected to be published in June. Analysis of the helium recovery system has been completed and the basic problem, brittle fracture of inlet connections through excessive cooldown, has been found unlikely to occur. We have analyzed the limitations to rapid recycle of the PLS and suggested an approach. Other studies conducted during the reporting period included bolt-torquing tests for flange bolts in the PLS LO₂ piping system, an approach for analyzing flow rates by reducing the flow circuits to equivalent valve flow coefficients, and the verification of the following: minimum values for the contents of PLS vessels during load - reload operations, depletion within tolerance during standby, and sufficient helium in titanium spheres aboard the missile.



II. FIELD TECHNICAL OBSERVATION AND START-UP ACTIVITIES

A. BEALE AIR FORCE BASE

1. Completion of Launcher 4C-1 Rebuild

Launcher 4C-1 at Beale Air Force Base was turned over to SAC on 8 March 1963, culminating an accelerated rebuild program begun in August 1962.

2. ADL Operation

Throughout the rebuild, ADL functioned on the staff of Lt. Col. T. D. Ryan, SATAF Deputy for Engineering, as PLS Engineer, lending assistance also as required on the RP-1 system. During the construction phase, we were located with the Construction Branch of the Corps of Engineers and were directly involved in all decisions regarding the PLS.

During the I & C operations, ADL provided technical assistance to American Machine and Foundry Co., while they had custody and maintenance of the PLS, and worked closely with The Martin Company in their testing operations.

3. Review of Contract Drawings and Specifications

ADL conducted an informal review of the contract drawings and specifications for the rebuild of launcher 4C-1. Several changes to pipe supports which had been incorporated during the original construction effort were found to have been omitted from the rebuilt launcher. In addition, several FCR's which had been incorporated in the other Beale launchers by Martin Company during the I & C phase were not included.

In response to our recommendations, all such changes were added to the rebuild contract, and therefore no work other than normal checkout was required on the PLS during the I & C phase.

4. Extent of PLS Rebuild

All PLS transfer panel instruments were replaced. This work was performed in the field, with the panels themselves being cleaned and refinished locally.

All Kieley & Mueller valves were removed and rebuilt locally with parts being replaced as required. The welded Powell manual valves were not removed but were leak-tested in place; packing and stems were replaced.

Pitting on the external surfaces of the PT piping, which was due to the action of moisture with the residue from the fire between the time of the fire and the start of the rebuild, was extensive. All schedule 5S LO₂ piping in the PT and the expansion joints was, therefore, replaced. All flexible hoses were replaced. The vent piping, the heavy wall piping in the PT, and the piping in the missile silo were replaced only when close inspection of individual sections showed it to be damaged. All piping in the vent shaft and interconnecting tunnel was replaced. All missile silo PLS piping was removed and recleaned.

Arthur D. Little, Inc.

Prior to the start of any replacement operations, and after all visibly damaged piping was removed, blowdown tests were made from the gas bottles in the PT through all remaining valves and piping to determine the cleanliness of the unremoved components. All were found to be satisfactorily clean except the remaining portion of line 301. Contamination was found in that line and was thought to have come from the improper handling during removal and replacement of the externally dirty S-302 strainer plug just prior to the testing. Line 301 was then removed in sections, cleaned and replaced.

In accordance with a revised design, when the vent shaft and inter-connecting tunnel were replaced, the portion of the vent tunnel between the radiation plate and the blast wall was built of aluminum. The air line through that section, formerly of black iron, is now stainless steel.

5. Inspection of T-201 LO₂ Tank

T-201 was entered to determine whether any contamination from the accident was in the tank. Many loose pieces of what appeared to be shattered 1/16-inch sheet teflon were found on the bottom and lower walls of the tank. There were also what appeared to be lint particles on the walls and inside the forward end of the pressurization header. A brown horizontal ring was evident near the 7,000-gallon level (about the height of the bottom of the gooseneck in the load line) on the back portions of the side walls and the rear end of the tank.

After removal of the various particles and an unsuccessful effort to remove the ring with various solvents, it was agreed that the tank appeared to meet the cleanliness requirements of BSD Exhibit 61-3C which had been made a part of the rebuild contract.

ADL felt, however, that further investigation of the nature of the discoloration should be made. At the request of BSSFR, Mr. Reynales of Space Technology Laboratories then visited launcher 4C-1 and entered the tank. After receipt of his report, it was the decision of BSSFR that no further action be taken toward cleaning the tank. The tank was then closed and satisfactory blowdown test pads were obtained from the tank nozzles.

6. AFBSD Exhibit 61-3C.

As mentioned above, the AFBSD cleanliness standard Exhibit 61-3C was incorporated into the Chico rebuild contract. It was noted, however, that this document included no criteria for water content (dew point) or acetylene content in gas samples taken from liquid oxygen, gaseous nitrogen, or helium systems. These criteria were therefore developed locally in accordance with the fluid use limits given in the same document.

7. Removal of LN₂ from T-201

Because there would be no further need for liquid nitrogen in the LO₂ tank following Corps of Engineers' acceptance testing, and because it was necessary to preclude any future problem of liquid nitrogen contamination of the liquid oxygen which would later be loaded into the LO₂ tank, the acceptance

Arthur D. Little, Inc.

cold test was modified to include pumping all of the LN₂ from the tank during test N. The tank was then kept under a gaseous nitrogen blanket until it was filled with liquid oxygen.

8. High-Pressure Kieley & Mueller Valve Seat

During the I & C phase, a slow continuous pressure build-up was noted on PI-509, the 750 psi pneumatic loop. Investigation disclosed a broken seat on FCV-508. The seat and plug were immediately replaced.

Later research determined that, during the check of Kieley & Mueller valves conducted early in 1962, this same valve was found to have a seat leak because of a scored seat. At that time, both seat and plug were replaced.

In view of these two seat failures in this valve, ADL then recommended that, at some convenient time, the entire valve be replaced. This recommendation was rescinded later, however, when it was found that the replacement valve which had been obtained had also previously had a broken seat.

It should be noted here that all except a small portion of the broken seat of the first mentioned FCV-508 was recovered on the filter element, F9521-512, on the launcher mast. Because of the small size of the missing portion, the nature and use of the affected line, and the evidence that the filter was performing its limited function, it was decided with ADL concurrence that any further search for the missing piece of valve seat was unwarranted.

9. Liquid-Oxygen Loadings

During all liquid-oxygen loading demonstrations, the propellant-loading system performed satisfactorily.

The first attempt of AEP 12, run 5.2, ended at T-1 with a flight control problem. The first attempt of AEP 15 ended at T-190 due to failure of the Stage I missile fill-and-drain valve to close. All other wet runs were successful.

It was noted during the first attempt at AEP 12 that, after some twenty to thirty minutes of the one-hour hold, Stage I topped down for the balance of the hold period, leading to suspicion that the topping down position of valve FCV-202 was too far open. Calibration of I/P 202 and the valve positioner on FCV-202 was checked. The positioner was adjusted and the system gave normal topping action in later demonstrations.

10. Incorrect Impedance in Spare I/P Transducers

During Martin Company electrical checkouts, it was discovered that the internal impedance of the I/P 201 was not 400 ohms as specified, but 180 ohms, which is not compatible with Martin Company equipment. A check of two other similar units from Air Force spares showed them also to have only 180-ohm impedances.

Arthur D. Little, Inc.

cold test was modified to include pumping all of the LN₂ from the tank during test N. The tank was then kept under a gaseous nitrogen blanket until it was filled with liquid oxygen.

8. High-Pressure Kieley & Mueller Valve Seat

During the I & C phase, a slow continuous pressure build-up was noted on PI-509, the 750 psi pneumatic loop. Investigation disclosed a broken seat on FCV-508. The seat and plug were immediately replaced.

Later research determined that, during the check of Kieley & Mueller valves conducted early in 1962, this same valve was found to have a seat leak because of a scored seat. At that time, both seat and plug were replaced.

In view of these two seat failures in this valve, ADL then recommended that, at some convenient time, the entire valve be replaced. This recommendation was rescinded later, however, when it was found that the replacement valve which had been obtained had also previously had a broken seat.

It should be noted here that all except a small portion of the broken seat of the first mentioned FCV-508 was recovered on the filter element, F9521-512, on the launcher mast. Because of the small size of the missing portion, the nature and use of the affected line, and the evidence that the filter was performing its limited function, it was decided with ADL concurrence that any further search for the missing piece of valve seat was unwarranted.

9. Liquid-Oxygen Loadings

During all liquid-oxygen loading demonstrations, the propellant-loading system performed satisfactorily.

The first attempt of AEP 12, run 5.2, ended at T-1 with a flight control problem. The first attempt of AEP 15 ended at T-190 due to failure of the Stage I missile fill-and-drain valve to close. All other wet runs were successful.

It was noted during the first attempt at AEP 12 that, after some twenty to thirty minutes of the one-hour hold, Stage I topped down for the balance of the hold period, leading to suspicion that the topping down position of valve FCV-202 was too far open. Calibration of I/P 202 and the valve positioner on FCV-202 was checked. The positioner was adjusted and the system gave normal topping action in later demonstrations.

10. Incorrect Impedance in Spare I/P Transducers

During Martin Company electrical checkouts, it was discovered that the internal impedance of the I/P 201 was not 400 ohms as specified, but 180 ohms, which is not compatible with Martin Company equipment. A check of two other similar units from Air Force spares showed them also to have only 180-ohm impedances.

Arthur D. Little, Inc.

The I/P 202 transducer (by specification the same as I/P 201) that had been installed was checked and found to conform to the 400-ohm specification. It was then noted that a 220-ohm resistor had been installed in series with the coil of the unit. Conversations with Fisher Governor Company, the manufacturer, indicated that the addition of this resistor to their standard 180-ohm unit was all that was required to meet the contract specifications.

This resistor was then added to the installed I/P 201 and, through SATAF, SBAMA was alerted that all spare I/P transducers should be checked for the same deficiency.

11. Liquid Sensors

At the request of STL, and in connection with the Flight Controls grounding problem, ADL looked at the Minneapolis-Honeywell LO₂ sensors in the missile silo at launcher 4A3 at Lincoln, California. It was found that wiring was in accordance with the MH schematic, except that LS-203, LS-204, LS-205, and LS-206 had filters installed. It is believed that these are the only filters installed in liquid sensors at T-5 or, in fact, at any Titan I facility (see Section III.A, paragraph 2).

12. Field Office Termination

Arthur D. Little, Inc., completed its contractual obligation at Beale Air Force Base during the quarter and on 31 March 1963 concluded residency and the field office function.

III. PROPELLANT-LOADING SYSTEM FOR WS 107A-2

A. SYSTEM STATUS

1. Change Requests

We initiated no change requests during this reporting period.

2. Liquid Sensors

A noise-sensitivity problem with the Minneapolis-Honeywell facility liquid sensors has recently been uncovered. A number of sensors triggered, i.e., indicated "wet" when the hydraulic power supply was energized. Additional units triggered when 400 cps missile power was applied. The Martin Company proposed correcting the deficiency by using a sensor filter system designed by Minneapolis-Honeywell. This system has been successfully proved under simulated noise environments.

On reviewing the sensor circuit diagram, ADL found that adequate isolation between the detector and the amplifier had not been provided. Since the detector, through the probe, is connected to facility ground, and the amplifier to GOE ground, a ground loop situation exists. Furthermore, the liquid sensors violate the single-point grounding requirement. In 1958 this discrepancy was brought to the manufacturer's attention on an earlier sensor design. He subsequently provided a transformer coupling for those units. This modification is presently installed at Vandenberg Air Force Base. It is ADL's opinion that, because of their previous exposure to the noise problem, the manufacturer should have provided for it in the subsequent design.

In the performance of tests designed to provide a measurement of noise amplitude and frequency (0.3 volts peak to peak at 7 kc), it was observed that the noise level diminished and normal sensor operation was restored when GOE ground was connected to missile ground. Although this approach is not a perfect solution, it certainly would be economical and therefore warrants further consideration; at least the effect on the over-all system such a change would have should be determined.

Should the solution to the noise susceptibility problem rest on the choice between control unit modification (i.e., transformer coupling and elimination of some chassis grounds) and purchase of a filter module, ADL would recommend the latter, since it would not involve shipment of the control units to the vendor's plant.

ADL participated in the solution of this liquid sensor problem at the request of STL. Our opinions were passed on to STL at a meeting attended by AFBSD, Martin, STL, and ADL on 1 February 1963, and via a series of phone conversations subsequent to the meeting.

Arthur D. Little, Inc.

3. Helium-System Leaks

We attended a meeting at Norton Air Force Base on 26 February to discuss helium-system leaks. As discussed in the previous progress report, a procedure using cold helium at 3200 psig was developed at Vandenberg Air Force Base to leak-test the helium system. The procedure had proved highly successful.

At the meeting at Norton, it was decided that the VAFB-generated procedure be used to leak-test the helium system. Basically the procedure is:

1. The facility is to be leak-checked with warm helium and then cold helium upon the receipt of a missile. The cold-helium tests are to be accomplished with a test tool at the QD so that the entire facility piping would get the 3200 psig cold-helium leak-test.
2. The facility and missile then is leak-tested together with warm helium.
3. The final check would be an LO₂ load with a depletion that is no greater than 1800 psi in the helium storage bottle.

Subsequent facility leak-testing would then be accomplished as a result of an unacceptable LO₂ load; that is, when helium usage is greater than 1800 psi.

If step 2, above, reveals that leakage is greater than allowable and the leak cannot be found upstream of the missile, an additional leak-check of the missile would be required. This check, known as the 4140 test, consists of monitoring the pressure in the empty missile with the vents and fill-and-drain valves closed and the spheres pressurized.

4. Differential-Pressure Gauges for LO₂ Filters

The specifications for the LO₂ system filters requires that each filter unit contain a differential-pressure gauge. The gauge would give an indication of when the filter was contaminated and required replacement.

Some of the pressure gauges were affected by the pressure surge during line cooldown and required frequent recalibration. When STL asked our opinion on this problem, we concurred with STL's recommendation that the gauges be removed and the filter unit be replaced at time intervals determined by operational experience.

B. VANDENBERG AIR FORCE BASE TITAN I ACTIVITIES

1. Summary

Our activity at Vandenberg AFB for this period was mainly concerned with the completion of the Category II program and participation in the Operational Verification Program (OVP) and the Penetration Aids (PA) Program. We wrote

Arthur D. Little, Inc.

a summary report on the objectives and results of the Category II Program, and participated at Martin-Denver on the coordination of a final report to be issued by the Martin Company.

2. Category II Program

On 18, 21, 23, and 24 January we participated in Attempts 1, 2, 3 and 4 respectively of the LO₂-only CSE and on 29 January, in the successful launch of the SM-8 missile from launcher 1. There were no PLS anomalies present. The launch of SM-8, and the previous launches of SM-35 and SM-11, concluded the Category II Program.

At Denver, during the weeks of 11 and 25 March, we assisted Martin-Denver in the preparation of the final Category II report. Final review and sign-off is scheduled for the week of 15 April.

3. Operational Verification Program (OVP)

The LO₂-only CSE of the SM-3 was completed on the first attempt on 19 March and was followed by a successful launch from launcher 2 on 30 March. We participated as usual in these operations and found the PLS to be in a satisfactory operating condition. Exercises for SM-1 are scheduled for completion in April.

4. Penetration Aids (PA) Program

We participated in the four LO₂-only CSE attempts for the V-1 missile; two on 15 March and another two on 16 March. A launch attempt was conducted on 23 March and again on 25 March, the latter being successful. The PLS was satisfactory in all respects. Exercises for the V-4 missile are scheduled in April and May.

5. Working Group Activities

We participated regularly in the daily scheduling meeting (TMC), weekly management meeting (BSD), OVP and PA working groups and readiness meetings, and other unscheduled meetings. Flight Test Directives, Detailed Flight Test Plans, and related documents were reviewed by this office and signed off with our concurrence.

6. Vent-Valve Cycling Exercises

During the post-unload period of two LO₂ CSE's of the V-1 missile in launcher 1, we conducted a vent-valve cycling exercise to determine what reduction of catch-pot boiloff time could be expected if valve FCV-306 was manually held open until its full-open position was attained coincident with the full-open position of valve FCV-305. Preliminary results seem to indicate that the catch-pot liquid level would be such as to allow recycle of umbilical drain after approximately 2-1/2 hours rather than the presently required 4-1/2 hours. However, results obtained from the two runs are non-conclusive since we had two different conditions during our exercise; the

Arthur D. Little, Inc.

first with the silo air purge and suction head recorder in operation, the second without either of these in operation. Physical inspection showed a definite slow-down of boiloff without silo purge. A further discussion of this item can be found in Section C, Special Studies.

Further exercises are expected to be performed during launcher 1 tests where they do not interfere with main test objectives. In order to fully evaluate the rapid recycle situation, we suggested a delay of 45-60 seconds after LS-203 drops out before initiating stop unload.

7. Helium Recovery

During the Category II SM-8 CSE exercises, we installed a thermocouple (TC-1) in the recovery line adjacent to the recovery valve CV-604 and recorded flow temperatures during the recovery phase. We found the lowest temperature to be -86 F with an initial pressure of 100 psig in the tube-bank trailer, and we recovered an average of 45 pounds of helium.

We conducted more runs during the V-1 missile exercises and installed a second thermocouple (TC-2) in the gas stream just ahead of the main block valve on the trailer. We recorded a low of -150 F (TC-1) and -130 F (TC-2) with an initial pressure of 250 psi in the trailer. Inclement weather prevented our intended installation of skin thermocouples. However, we did get a run with one (TC-4S) located on the skin of one of the inlet valves to the individual trailer tubes, and we recorded -98 F (TC-1), -82 F (TC-2), and -30 F (TC-4S) with an initial 500 psi trailer pressure.

On a run made during the SM-1 missile exercises we had the following setup on thermocouples: TC-1 and TC-2 in gas stream as above, TC-3S and TC-4S on the skin of two inlet valves, and TC-5S and TC-6S on the skin of the nozzle neck of two individual tubes. We recorded lows of -99 F (TC-1), -82 F (TC-2) and 0 F (TC-3S). The others (TC-4S, 5S, 6S) gave no indication on the recorder. However, they were calibrated, which means that they were in the temperature zone above plus 10 F. (Note: We were unable to induce a bucking voltage into the recorder which would have allowed us to read ambient temperatures.)

Data on helium recovery have been compiled and are discussed in Section C. At present, the trends are so erratic that it is difficult to predict temperatures on the nozzle necks of tubes for helium recovery at T-280. All above data were obtained after "lower launcher" (one hour or more after T-280).

8. Engineering Assistance and Consultation

During all CSE and launch activities, ADL maintained a post in the Control Center and observed operation of the PLS (SECON) and associated equipment. We participated in all pre-test and post-test discussions and furnished a seven-day test report to the Martin Company. We continue frequent monitoring of the PLS facility and participate in all related meetings.

Arthur D. Little, Inc.

At the request of Captain B. P. Foley of AFLC/VAFB, we held a discussion with Mr. G. Akins of Mobile Air Material Command (MOAMA) and Mr. D. E. Wimer of Stearns-Roger concerning materials used for process pipe and vessels and the related welding procedures for the several PLS installations at VAFB. We discussed data from the Atlas D & E (horizontal), Atlas F (silo), Atlas and Agena at Point Arguello, and Titan I. Messrs. Akins and Wimer have been assigned a task of investigating these data with the ultimate objective being to document welding procedures and qualifications for military personnel.

ADL participated in the discussions of helium leaks in the airborne systems for Titan that were conducted at Norton AFB with BSD and STL.

In a letter dated 4 March we advised the Martin Company concerning gasket leaks on the LO₂ unloading pump.

In several field discussions we gave advice to SAC and AFLC regarding the overheating of vacuum pumps used on the PLS cryogenic vessels. They have been realizing temperatures between 150 and 180 F; we advised them that these temperatures are within the normal operating range for the Kinney Pump.

We advised the Martin Company that:

1. The hold time at T-280 could approach six hours under certain conditions since the pacing item was the LO₂ subcooler.
2. An inadvertent filling of T-503 with helium would have no harmful effect on PLS operation during the launch of SM-3.

9. Administrative Changes

On 25 January, Mr. L. S. Peak departed this assignment for duties at Santa Monica.

On 31 December, J. P. Sullivan concluded duties with the office of Director of Civil Engineering at VAFB and joined the ADL Test Group on 1 January.

Effective 28 January, at the direction of S. S. Waldron, duties of Base Manager were assumed by J. P. Sullivan.

C. SPECIAL STUDIES

1. Liquid Sensor Test Program

Response and repeatability tests of liquid sensors in liquid hydrogen have been completed on all but four of the test specimens. The remaining units to be tested are those manufactured by Instruments, Inc., Compudyne, Minneapolis-Honeywell, and Automation Products; these will be tested late in April.

All data which have been recorded to date have been reduced and are now being analyzed. Barring unforeseen retest requirements, we anticipate publishing the final report during the month of June.

Arthur D. Little, Inc., has performed some additional testing on liquid sensors under contract to North American Aviation. Data, results, and conclusions from this study will be incorporated in the final report.

2. Helium Recovery

During the last quarter, several tests were run at Vandenberg Air Force Base on helium recovery. Some of these tests measured temperatures at the helium-recovery connection to the trailer as well as metal temperatures on the tube trailer itself.

The basic problem with helium recovery is to prevent tube trailer cooldown to such an extent that it could fail by brittle fracture. The mass of the gas is small enough that there is no possibility of cooling down the whole tube trailer; however, local cold spots might occur that would be dangerous. The location most susceptible to cooldown is the inlet connection on the tube trailers. The purpose of the Vandenberg tests was to determine temperatures at such critical locations under various recovery conditions.

In order to gain some insight into the over-all problem, an analytical program was conducted while test data were being obtained. The purpose of the analytical program was to determine whether the one-hour hold period after shutdown was necessary. All tests at VAFB had a normal elapsed time of one hour between the time of shutdown and helium recovery so that the insulated portion of the line would warm up to insure that warmer gas would be delivered to the tube trailer.

A schematic diagram of the helium-loading and recovery system is shown in Figure 1. The gas aboard the missile is stored at -297 F in spheres immersed in the LO₂ tank. During recovery, the gas flows through an insulated line which has been cooled down to some extent during helium loading (and allowed to warm up during hold and shutdown periods) and then proceeds through an uninsulated warm line to the recovery connection at the surface (Figure 1). A flexible line about 20 feet long carries the gas to the helium recovery trailer.

Arthur D. Little, Inc.

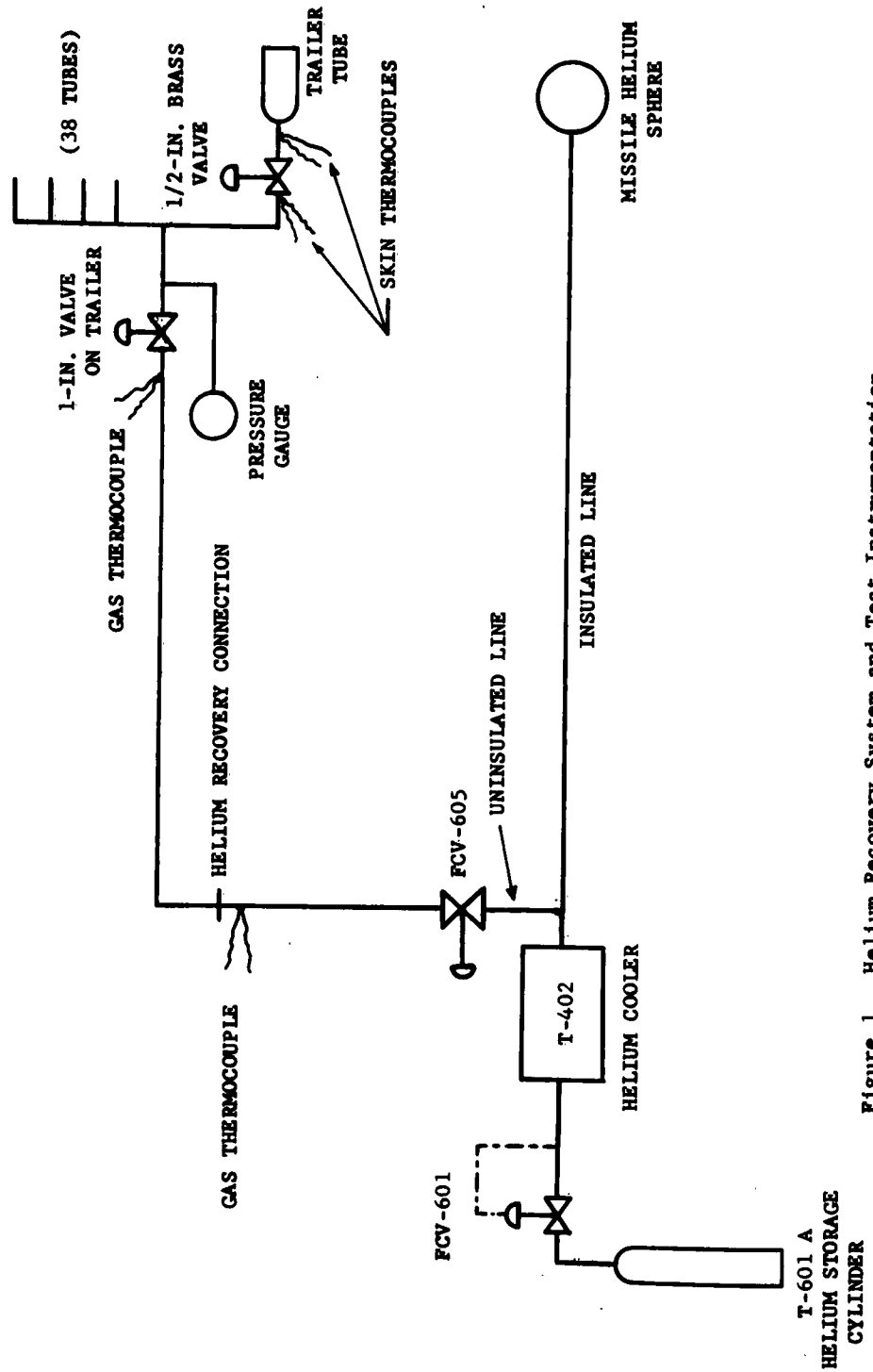

Figure 1. Helium Recovery System and Test Instrumentation

Figure 2 is a sketch of the helium-recovery trailer. The trailer consists of 38 equal size tubes approximately 9-5/8 inches in diameter and 20 ft 8 inches long. Each tube has a 1/2-inch brass valve and the manifold tubing is 1 inch.

The results of all the helium-recovery tests are shown in Table 1. The data obtained for Runs No. 3 and 7 were not used for the reasons noted. Actual test data obtained are shown in Figure 3.

a. Analysis. The analysis was directed toward determining whether helium recovery could safely be conducted immediately upon shutdown without a waiting period for the insulated transfer portion of the recovery line to warm up. The analysis was divided into two phases: determination of gas temperature during recovery for a no-hold condition and tube wall temperature response to the cold flowing gas.

(1) Gas Temperature During Recovery. The gas temperature at the recovery connection (see Figure 1) is a function of the temperature in the insulated and uninsulated portions of the line, the helium gas heat-transfer coefficient, the flow rate and the length of line. The only item above that can not be satisfactorily analyzed is the condition of the insulated line. Therefore, the analysis was performed in the uninsulated portion of the line downstream of FCV-605. It was assumed that gas was delivered from the insulated portion of the line at a constant, low temperature.

The calculation, therefore, is one of cold gas entering a warm line, cooling the line and leaving the line at a much warmer temperature than it entered. The problem is one of transient heat flow and it can be solved using a calculation technique which we have used previously and reported in Technical Report No. 9. The calculation technique is outlined in an article in the Transactions of the ASME, April 1954 (pp. 421-426) and is entitled "Calculation of Transient Temperatures in Pipes and Heat Exchangers by Numerical Methods," by G. M. Businberre. This technique is a numerical one and, in order to use it, the following assumptions were made.

1. The recovery line has constant cross-section, density, and specific heat.
2. The thermal conductivity of the line is zero in the axial direction and infinite in the radial direction.
3. The inside gas film heat-transfer coefficient is constant.
4. The helium gas inlet temperature is constant.
5. There is negligible axial heat conduction within the helium itself.
6. The outer wall is insulated.

In order to evaluate this technique, the calculated results must be compared with actual data. The first parameter that required evaluation was the gas temperature entering the uninsulated portion of the line for the condition of a one-hour waiting period and for an immediate recovery.

Arthur D. Little, Inc.

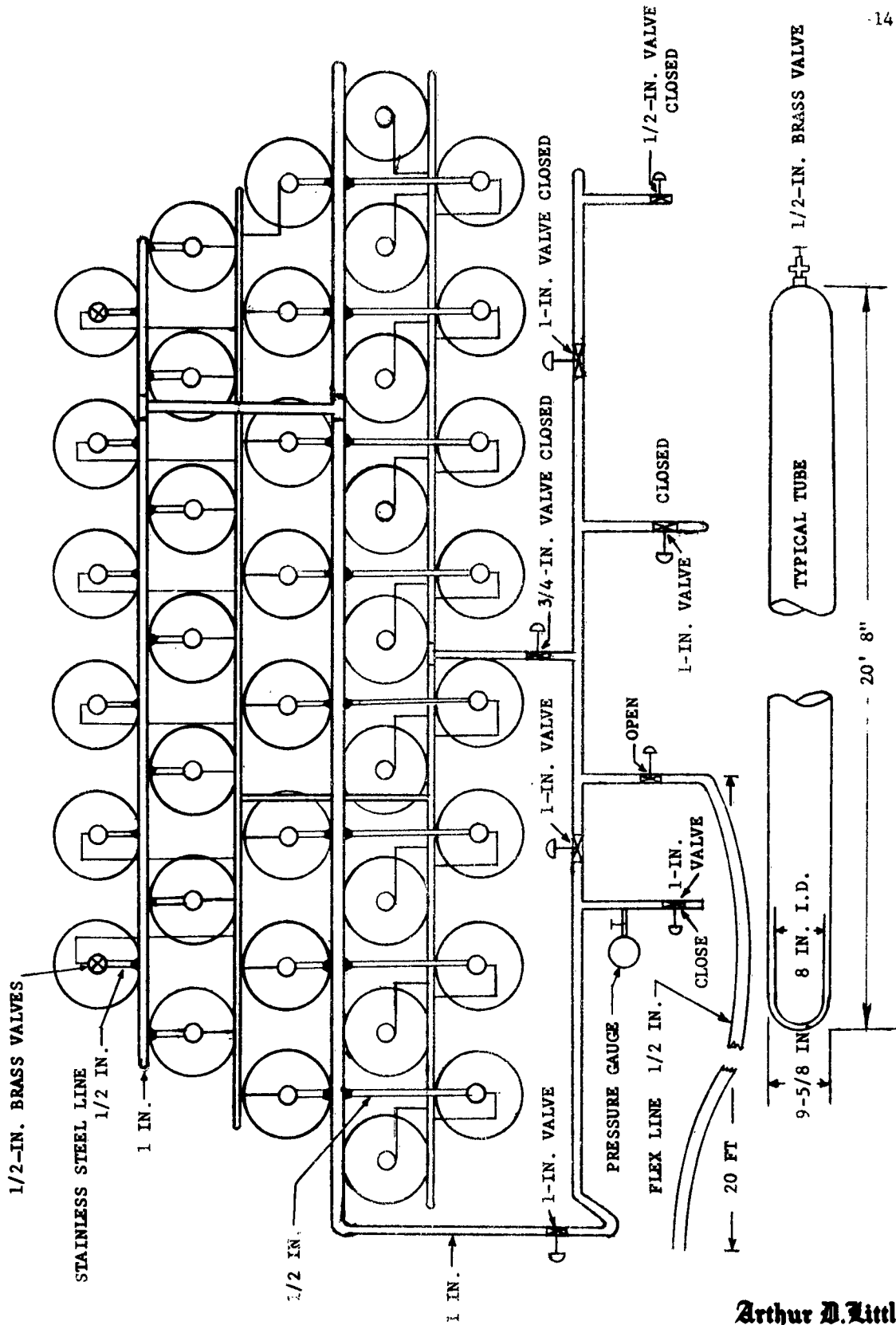

Figure 2. Helium-Recovery Trailer

Table I
Results of Helium-Recovery Tests

Run No.	Date	Helium Used (T-601) (lb)	Helium Recovered (lb)	Per Cent Recovered	Lowest Temp. Recorded (At CV-604) (deg F)	Helium Tube Bank Pressure (psig)		Time When Lowest Temp. Recorded (minutes)	Notes
						Initial	Final		
1	1/18/63	106.2	36.6	34	-29	450	600	1.9	
2	1/21/63	116	49.4	43	-86	100	300	3.9	
3	1/23/63	102.8	27	26	-23	300	412	2.0	(1)
4	1/24/63	99.5	40	35	-46	408	475	2.3	
5	3/15/63	116	62.5	54	-150	250	500	5.7	(2)
6	3/17/63	--	51	--	-97	500	700	4.2	(2)
7	4/2/63	--	30.3	--	-40	180	300	--	(2),(3)
8	4/3/63	123	49.8	41	-99	300	500	4.5	(2)

- (1) Complete helium recovery was not achieved for this run because a bleed valve near the recovery connection was left open.
- (2) These runs were made at launchers 1 and 3 with a missile which had aluminum spheres.
- (3) Recovery was halted before the pressures equalized between the spheres and the trailers.

Arthur D. Little, Inc.

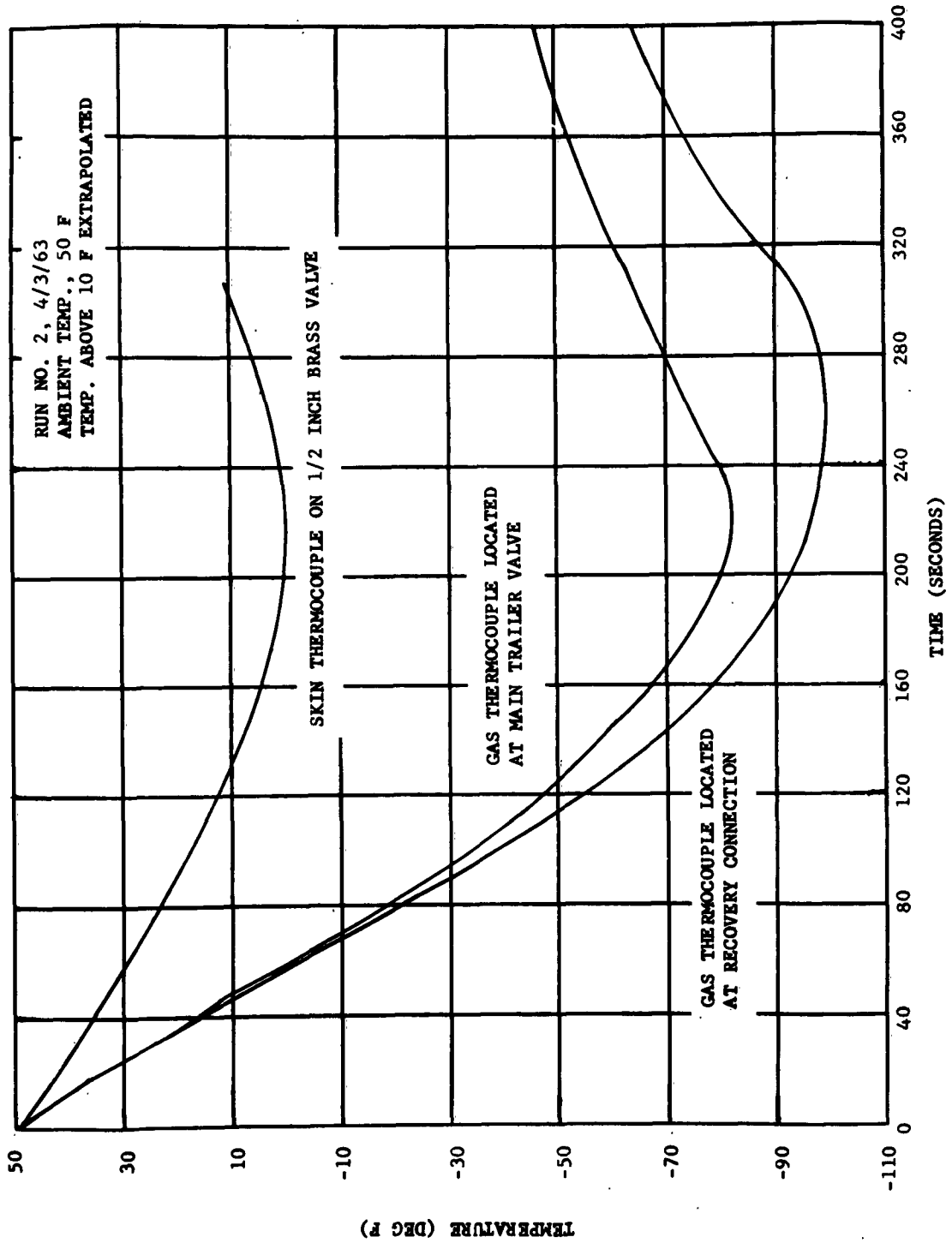

Figure 3. Thermocouple Data

During one test (Run No. 5), the temperature at the recovery connection stabilized at -150 F for more than a half minute before the pressures equalized in the sphere and the trailer. This meant that the gas which enters the uninsulated line after an hour hold has an approximate temperature of -150 F. This temperature was therefore used in the numerical calculations as the gas inlet temperature for the one-hour hold condition.

The length of the uninsulated portion of the line is about 103 feet, and this number was used in the initial heat-transfer calculations. It should be noted that the system contains flanges, anchors, and supports which will add to the cooldown requirements of the system and thus the 103 feet must be corrected. This was done as discussed below.

The helium flow rate during recovery is over 30 lb/min initially and falls to zero when the pressures equalize. Several calculations were made at constant flow rates to determine the effect of flow rate on helium temperature at the recovery connection.

Figure 4 shows the results of the numerical calculation using a constant inlet temperature of -150 F, 103 feet of line, and flow rates of 5 and 30 lb/min. This graph reveals two important points: (1) that the effect of flow rate on gas temperature at the recovery connection is minor and (2) that the assumed length of line is too short (see gas temperature and weight recovered in Table I). The fact that the temperature is not flow-rate dependent is fortunate since, as noted above, the flow rate varies considerably during recovery. From Figure 4 it can be seen that using an average flow rate (for example, 15 lb/min) introduces little error.

The actual length of line (103 feet) is not sufficient to account for the total heat that is transferred to the cold gas. However, the total heat that is transferred to the cold gas by the warm line components can be easily determined by integrating under the curve of Figure 3. Converting this heat input into an equivalent length of line resulted in an equivalent length of 260 feet. With this equivalent length of line, the calculated gas temperatures at the recovery connection are shown in Figure 5 for gas inlet temperatures of -150 F and -300 F. The -300 F curve gives the temperature which would be expected if the helium was recovered immediately after shutdown with no waiting period for the insulated portion of the line to warm up. It can be seen from the graph that good agreement with TF-1 data is obtained for the tests in which greater amounts of helium (and hence lower temperatures) were recovered. Since the region of interest is the low-temperature part of this curve, the numerical technique yields satisfactory results. The calculated curve for the -300 F condition can, therefore, be used with confidence.

It should be noted that the data points obtained for the greater weights of gas recovered were with missiles containing aluminum spheres. These spheres have over 10% more volume than the titanium spheres that are now being used in all Titan missiles. It can be expected therefore that the amounts that will be usually recovered will be less than sixty pounds. This in turn means that the minimum temperature obtained will be greater than -300 F, even for the worst condition.

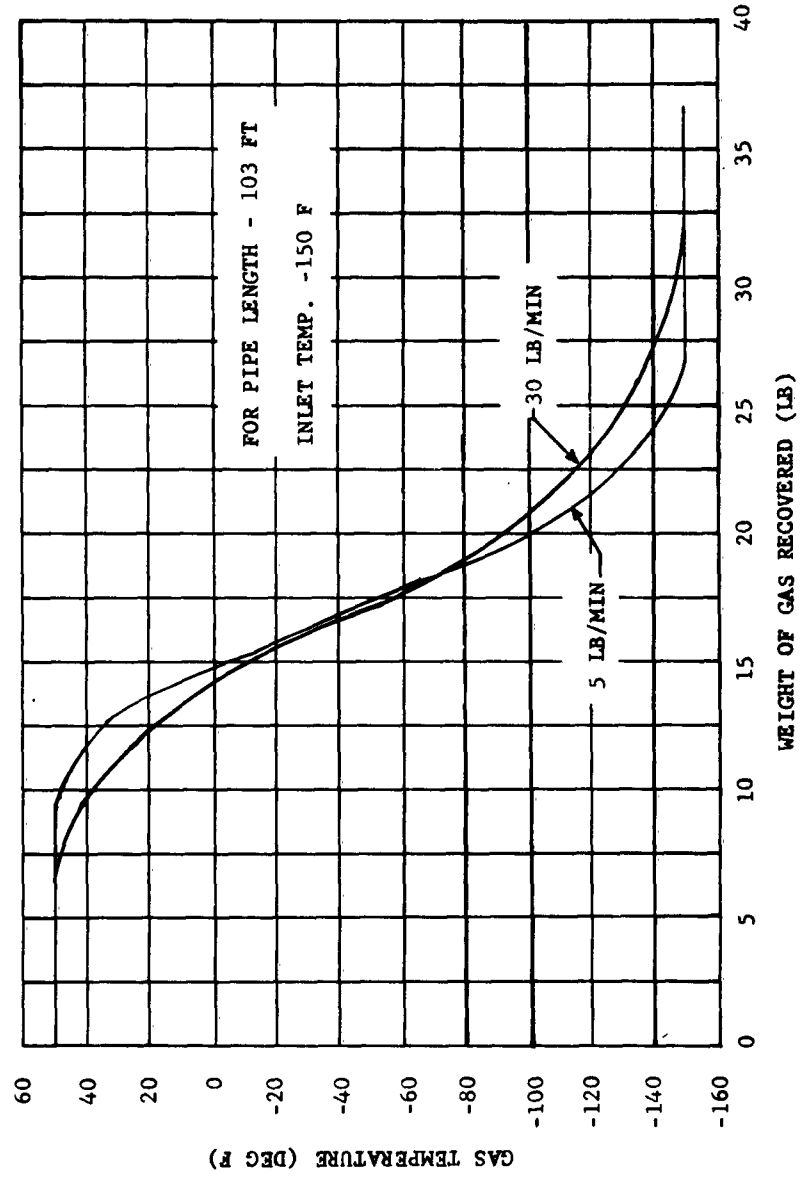

Figure 4. Effect of Flow Rate on Helium Temperature at Recovery Connection

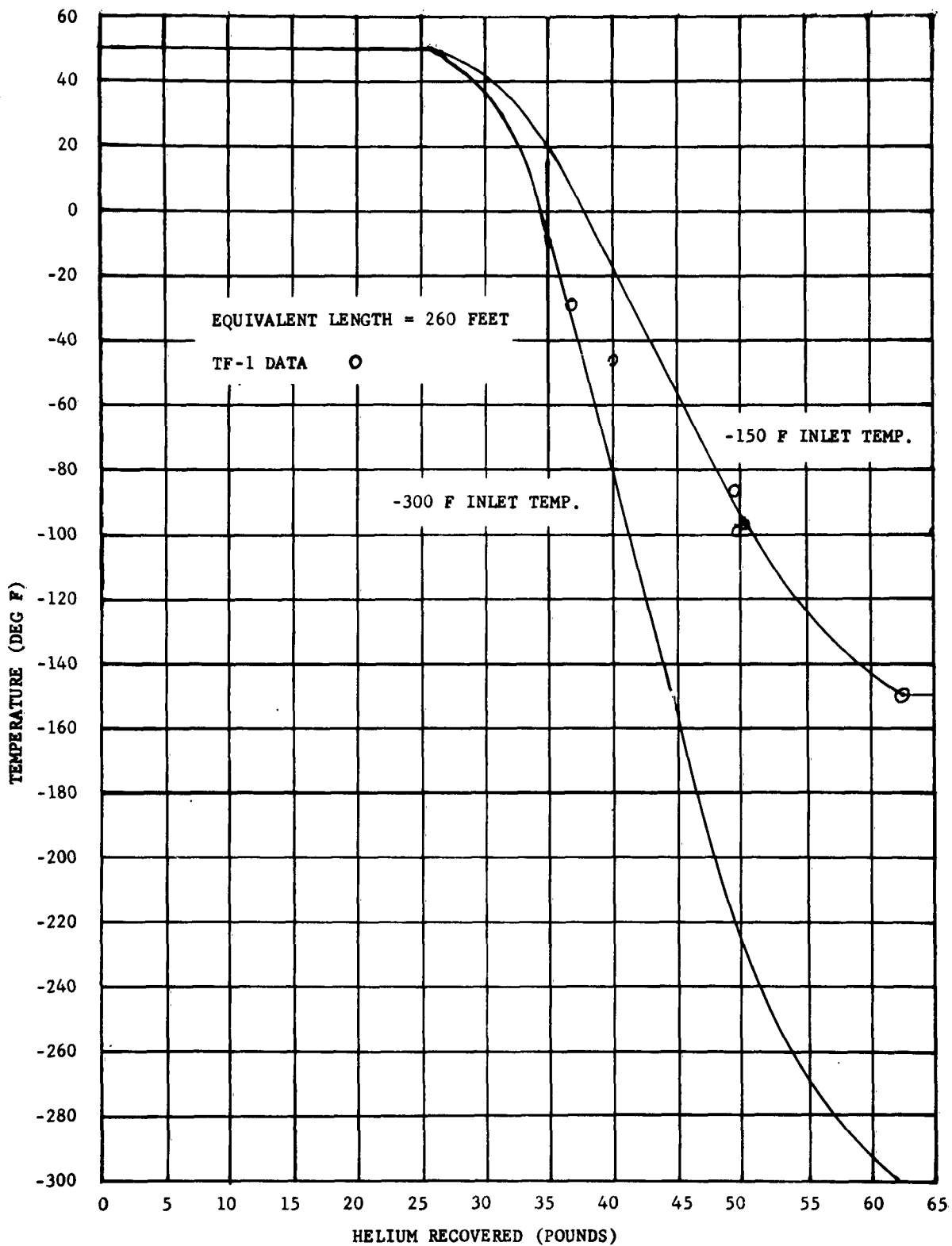

Figure 5. Calculated Temperature at Helium Recovery Connection

Arthur D. Little, Inc.

(2) Transient Response of Tube-Neck Wall. In the previous section, the gas temperature at the recovery connection was determined. The gas temperature entering the tube trailer is somewhat warmer (see Figure 3) because of gas warmup in passing through about 20 feet of flexible hose and the manifold piping on the trailer.

The recovery gas stream is divided into 38 flow parts (i.e., 38 tubes) when it enters the trailer. Thus, each tube receives less than two pounds of cold gas. This small amount of gas is insufficient to cool the whole tube to a low temperature. However, it is sufficient, if perfect heat exchange existed, to cool the carbon steel inlet pipe on the tube to a very low temperature. The problem then is to determine the temperature of the tube inlet pipe when subjected to cold gas flow.

The tube inlet pipe is approximately 3-1/4 inches long, with an inside diameter of 3/4 inch and a wall thickness of approximately 1/2 inch. If a constant gas temperature, a constant gas heat-transfer coefficient, and no heat transfer on the outer wall are assumed, the following partial differential equation and boundary conditions hold:

$$\frac{\partial T}{\partial \tau} = \alpha \left(\frac{\partial^2 T}{\partial r^2} + \frac{1}{r} \frac{\partial T}{\partial r} \right)$$

with the following boundary conditions:

1. $T = T_a$ at $r = 0$ and $\tau = 0$.
2. $h_g (T_g - T_w) = -K \frac{dT}{dr}$ at $r = r_1$ and $\tau > 0$.
3. $-K \frac{dT}{dr} = 0$ at $r = r_e$ and $\tau > 0$.

where:

T = temperature

τ = time

α = thermal diffusivity

r - radial distance

h_g = heat-transfer coefficient of gas

K = thermal conductivity

a = ambient

g = gas

w = wall

i = internal

e = external

A closed solution for this equation can easily be found; however, determining the temperature distribution for a specific case requires finding the roots of an equation which contains Bessel functions. The solution has been plotted for various values of the controlling parameters by P. J. Schneider in a book entitled, Temperature Response Charts.

Using these plots we have determined the inlet tube-wall temperature for a recovery flow rate of 8 lb/min and for constant gas temperatures of -150 F and -300 F. The flow rate is the average rate obtained during the last half of recovery when the colder temperatures are obtained.

The results are shown in Figure 6. It can be seen that the wall temperature drops very slowly. Division of the flow stream into 38 parts accounts for the slow temperature drop. This results in a drastically reduced heat transfer coefficient in comparison with the main recovery line.

As shown in Figure 5, a constant-flow temperature of -300 F is never obtained. From Table I, the maximum flow time to obtain the lowest temperature is 5.7 minutes. Therefore, immediate recovery with a maximum amount recovered is equivalent to less than a three-minute flow time at -150 F. From Figure 6, the minimum inner wall temperature would only drop to 20 F, and the outer wall temperature would be several degrees higher. It is of interest to note that during tests at TF-1, the thermocouple on the outer wall was always greater than the maximum temperature readable on the recording system, i.e., higher than 10 F.

b. Recommendations. The above analysis shows that there is little chance of cooling the carbon-steel inlet tube to the trailer so much that it would be subject to brittle fracture. Since the analysis used conservative assumptions for gas temperature and time of exposure to this temperature, it is recommended that the hour waiting period be deleted. Also, the analysis indicates that the initial pressure in the recovery trailer tubes has little significance in terms of minimum trailer tube-neck temperatures since, even with maximum helium recovered, tube neck temperatures are still safe.

3. Rapid Recycle

During the last quarter we have been involved in conversations with various agencies as well as in tests at TF-1 to determine a method to reduce the time required between a LO₂ unload and a reload. Briefly, the limitations for rapid recycle, as far as the PLS is concerned, are:

1. Catchpots are too full to contain contents of umbilicals during second drain.
2. Stage I transfer line is partially filled, creating a possible slug-loading situation.

Arthur D. Little, Inc.

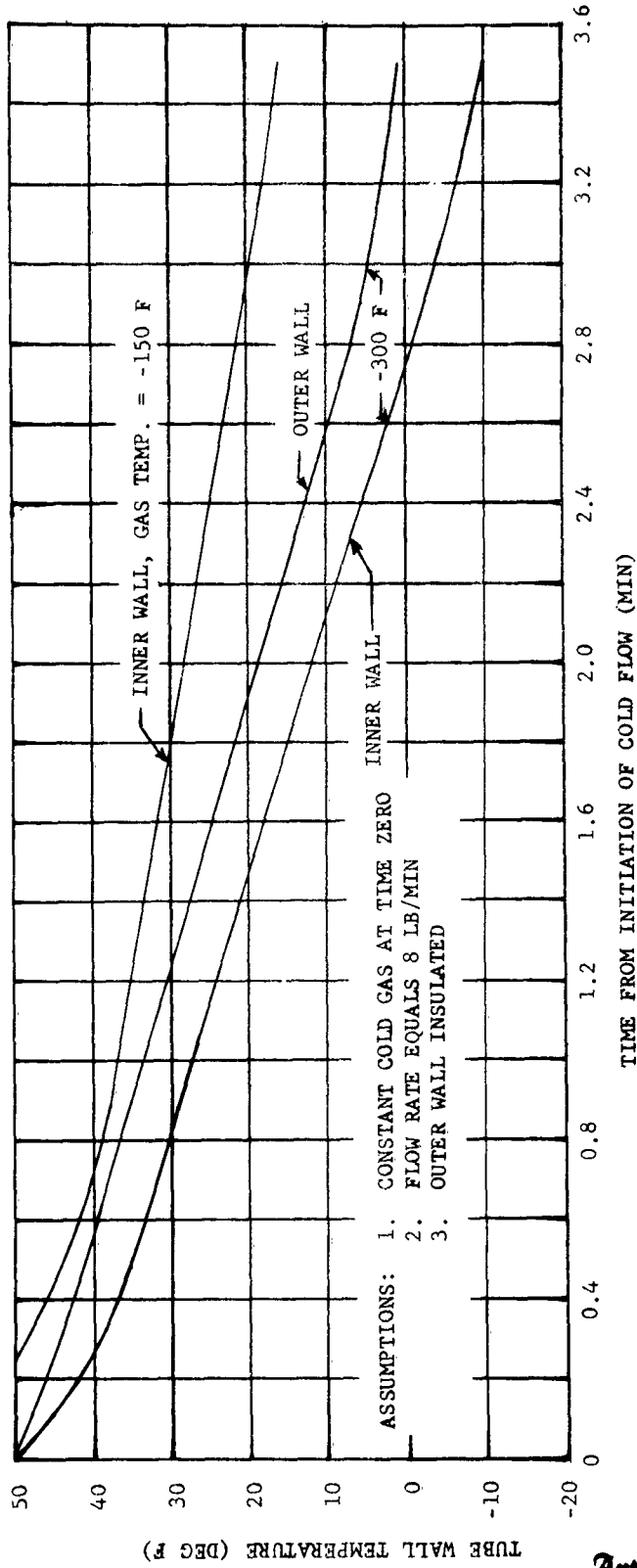

Figure 6. Inlet Tube Wall Temperature of Helium Trailer

The second limitation must be evaluated by others with regard to the Titan's ability (1) to withstand the forces involved in slug loading and (2) to withstand a possible sub-atmospheric pressure in the tanks.

The umbilicals can be drained sooner by installing catchpot drains. The drains are now installed at TF-1 and should be installed at all bases. The catchpot drains will be effective as long as the level in the drain circuit decreases at a reasonable rate. There are two phenomena which tend to keep the level in the drain line (suction side of the pump) high. One is the slow response of FCV-306 during drain line venting and the other is the backflow through FCV-208 when the pump stops.

The problem associated with the slow opening of FCV-306 was discussed in Progress Report No. 12. For this situation, we recommended that FCV-306 come fully open before it can close. This can be accomplished by adding a holding relay to the PS-205 circuit so that the signal transmitted to the equipment terminal will remain in until the FCV-306 open limit switch signal is received.

Backflow through FCV-208 occurs because of the following sequence of events. After Stage I has been unloaded, a signal is sent to stop the LO₂ pump and close the LO₂ unloading pump discharge valve, FCV-208. Since FCV-208 requires a finite time to close, some LO₂ will flow back into the drain line after the pump has stopped. No data are available on the time required for the pump to come to a complete stop and reverse itself, and no data are available on the impedance of the pump to backflow. With the impedance of the pump assumed to be negligible, the instantaneous backflow rates are calculated to be those given in Table 2.

Table 2. Backflow Rates

Liquid Level in Suction Line	Flow Rate (gal/min)	Rise Rate in Suction Line (ft/sec)
At Pump	500	5.7
At Stage I Catchpot	450	5.1
At Stage II Catchpot	230	2.6

The pump could probably drain the line down to within a few feet above the pump center line. According to Wyle tests, the closing time of FCV-208 is 5.2 seconds. Lowry closing times ranged from 7 to 9.5 seconds. These times were obtained without backflow, which would tend to close the valve faster. The specification requires that the valve close between 5 and 10 seconds. Since the distance between the Stage I catchpot (T-202) and the pump is approximately 20 feet, it can be seen from Table 2 and the valve closure time that the liquid level in the drain line when the valve closes will probably be above the Stage I catchpot level.

The procedure that is now followed in stopping the pump at the end of Stage I unload is to halt the unload immediately after LS-203 is uncovered. To drain the line as far as possible (that is until the pump cavitates), the operator should wait at least 10 seconds after LS-203 is uncovered. To also drain the catchpot (assuming drain lines are installed), we must wait a much longer time (several minutes).

The elimination of backflow requires that FCV-208 be closed before P-201 stops; i.e., have P-201 stopped by the FCV-208 CLS signal. We also suggest installing a pressure switch in the pump discharge line as a cavitation monitor to warn the operator of a pump malfunction during unload and signal NPSH decay for his "Stop Unload" command.

Some test data obtained at TF-1 indicate that about 4½ hours are now required to lower the level in the catchpot to accommodate a second drain. During one test, when FCV-306 was manually opened while FCV-305 opened and the silo purge was operating, the time was reduced to 2½ hours. These data are only preliminary. No tests were conducted in which FCV-208 was closed before pump shut-off.

The basic approach to rapid recycle depicted above was included in an ECP by Martin (A05533). However, the Martin Company has decided not to pursue rapid recycle at this time.

4. Bolt Torquing

We were requested by AFBSD to conduct a series of bolt-torquing tests to determine required torques for various sizes of flange bolts in the PLS LO₂ piping. The tests were performed in our Santa Monica laboratory and are summarized in the following paragraphs.

a. Test Approach. The bolt-torquing tests were performed using ASTM A 320, grade B8F bolts in accordance with the Corps of Engineers' specification. There are two possible bolt selections in the ASTM A 320 code under the B8F designation: (1) annealed and (2) annealed and strain-hardened. We used the annealed bolts in our tests. Either type is suitable for the subject application and the test results are applicable to either type. The bolts had standard heads, and heavy nuts were used. Before testing, the bolts were washed in acetone.

The test apparatus is shown in Figure 7. The head of the bolt was fastened in a vise and the following placed over the bolt: a plate, the strain collar, another plate, and finally the nut. Strain-gauge readings were taken on an SR-4 Portable Strain Indicator. The strain gauges were temperature compensated. Torque was applied to the nut with a Snap-On Tools Corporation torque wrench which had been calibrated before the tests were conducted.

Diameters of bolts tested were 1/2, 5/8, 3/4, and 7/8 inches. Two bolts of each size were tested, and each of these bolts was tested under two conditions. The first bolt of each size was first torque-tested with

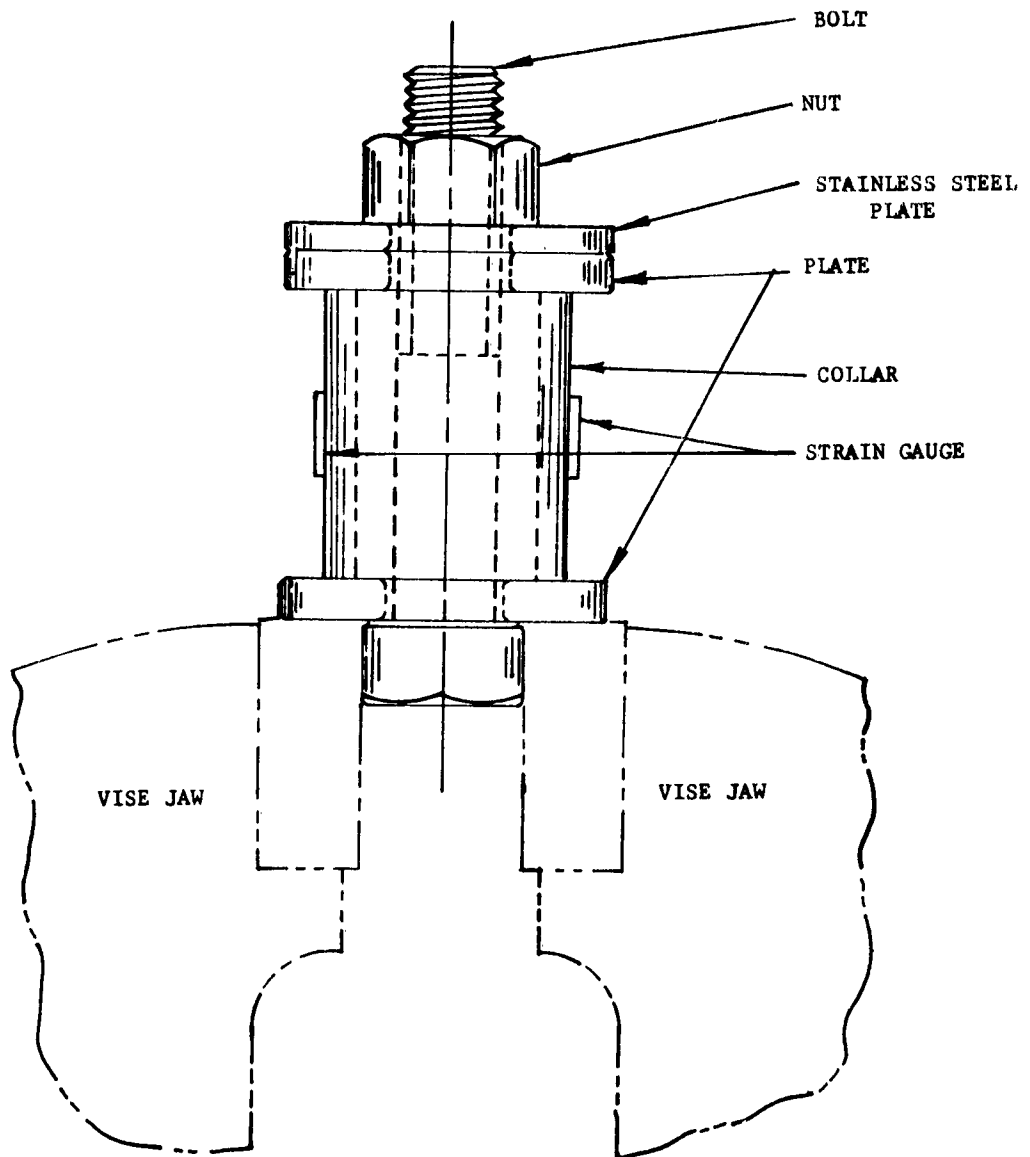

Figure 7. Sketch of Test Apparatus

the bolt and nut dry. It was then disassembled, the bolt lubricated with Fluorolube light greast, reassembled, and torque-tested. The second bolt of each size was first lubricated with Fluorolube light grease and torque-tested, and then the nut was loosened and the assembly was torque-tested again.

b. Test Results. The results of the tests are shown in Figures 8, 9, 10 and 11. The guaranteed minimum yield stress for the annealed bolts used in the tests is 30,000 psi. The bolt loads and the corresponding test torque values to get to the 30,000 psi yield point are given in the table below. The torque values given are a biased average of the test data obtained.

<u>Bolt Size</u> <u>(in.)</u>	<u>Yield Load</u> <u>(lb)</u>	<u>Torque</u> <u>(ft-lb)</u>
1/2	4,250	42
5/8	6,750	86
3/4	10,000	144
7/8	13,000	258

Figure 12 gives the averaged test data for all the bolt sizes showing percent of the bolt's yield load plotted against bolt torque. This plot is based on the bolts being lubricated with Fluorolube light grease.

c. Recommendations. We are recommending bolt torque values that, first, will give a sound joint for the subject cryogenic service and, second, will not result in undesirable flange distortion when considering slip-on type flanges. Specifically, the torque values we recommend result in a 70%-of-yield load in the annealed B8F bolts. A table of bolt sizes and torque values to obtain the recommended bolt loads is given below. This information is also shown in Figure 12.

<u>Bolt Size</u> <u>(in.)</u>	<u>Recommended Torque</u> <u>(ft-lb)</u>
1/2	30
5/8	60
3/4	100
7/8	180

The above recommendations are based on the bolts being lubricated with Fluorolube light grease. These recommendations hold for either the annealed or the annealed and strain-hardened type bolts. In addition, the assembly procedure described in our Quarterly Progress Report No. 13 should be used in the assembly of the joints.

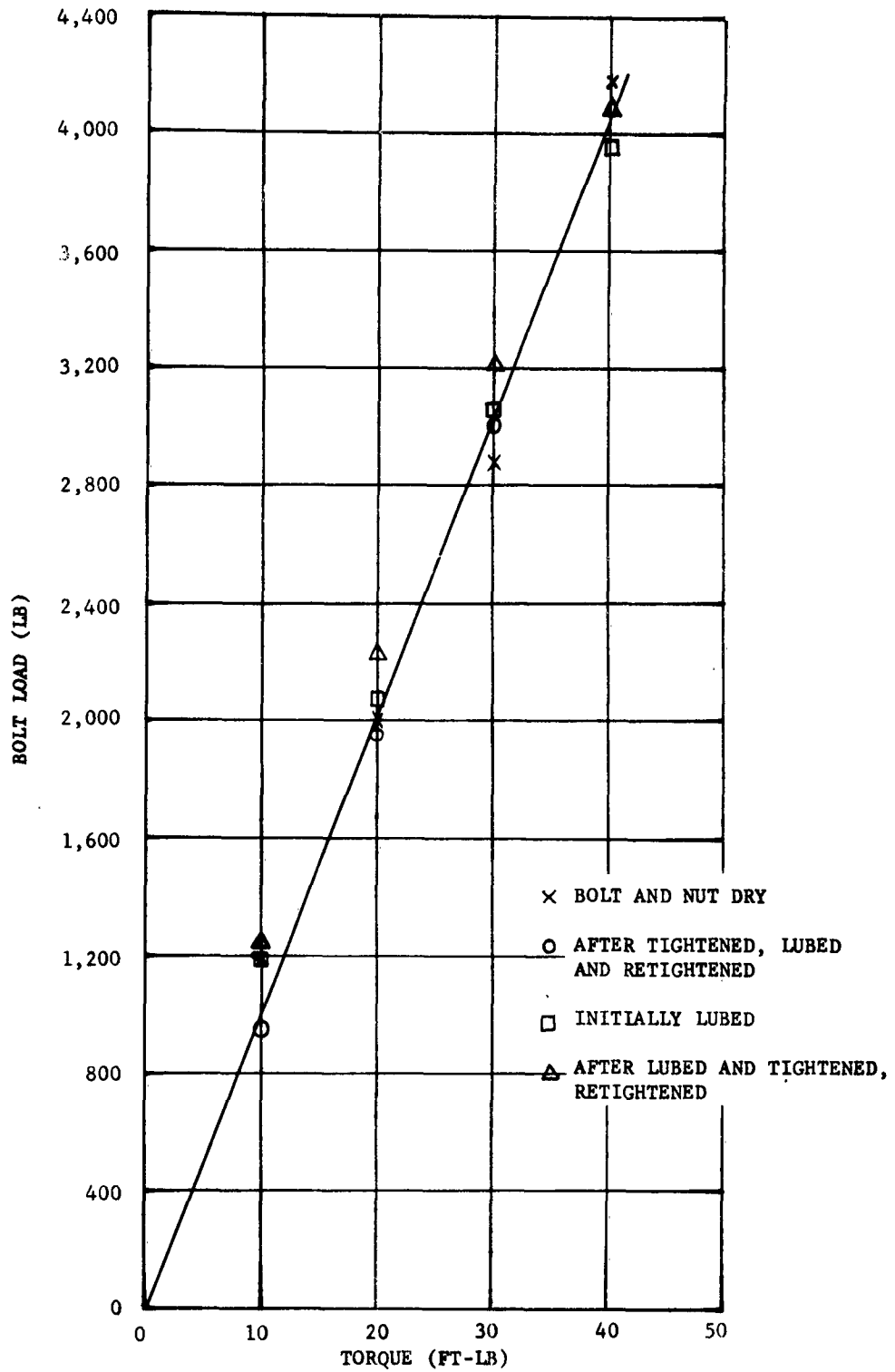

Figure 8. Test Data for 1/2-Inch Bolt

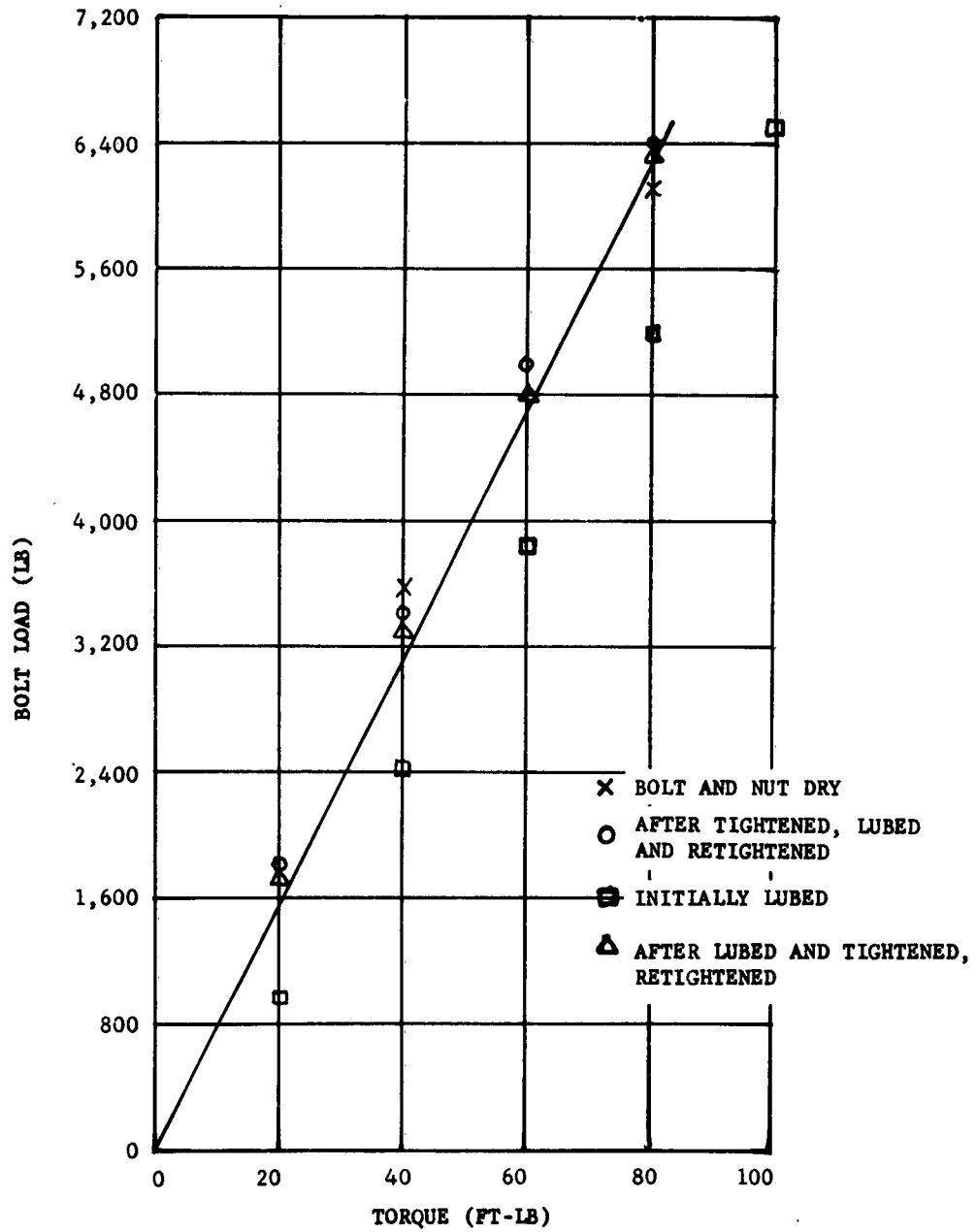

Figure 9. Test Data for 5/8-Inch Bolt

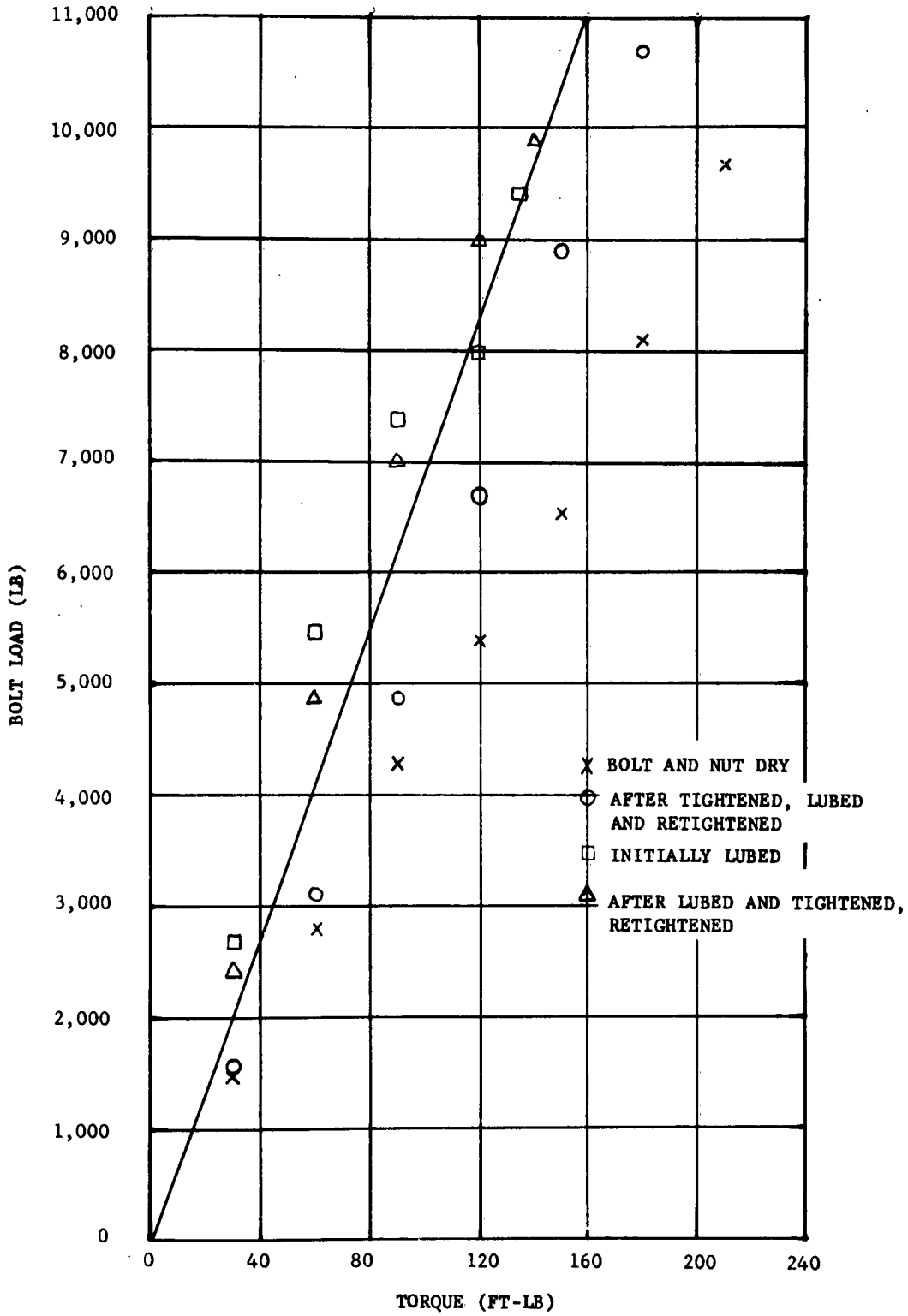

Figure 10. Test Data for 3/4-Inch Bolt

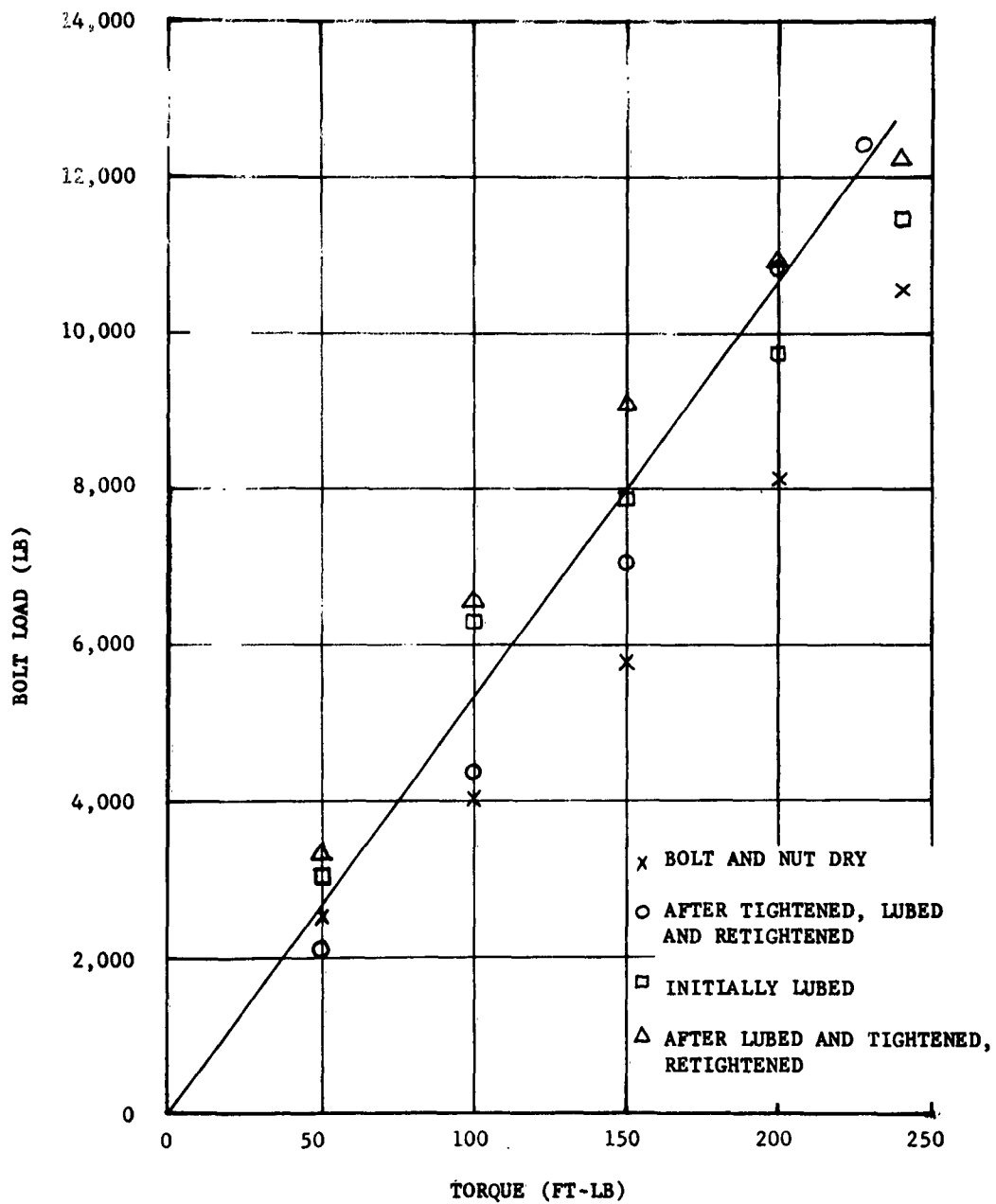

Figure 11. Test Data for 7/8-Inch Bolt

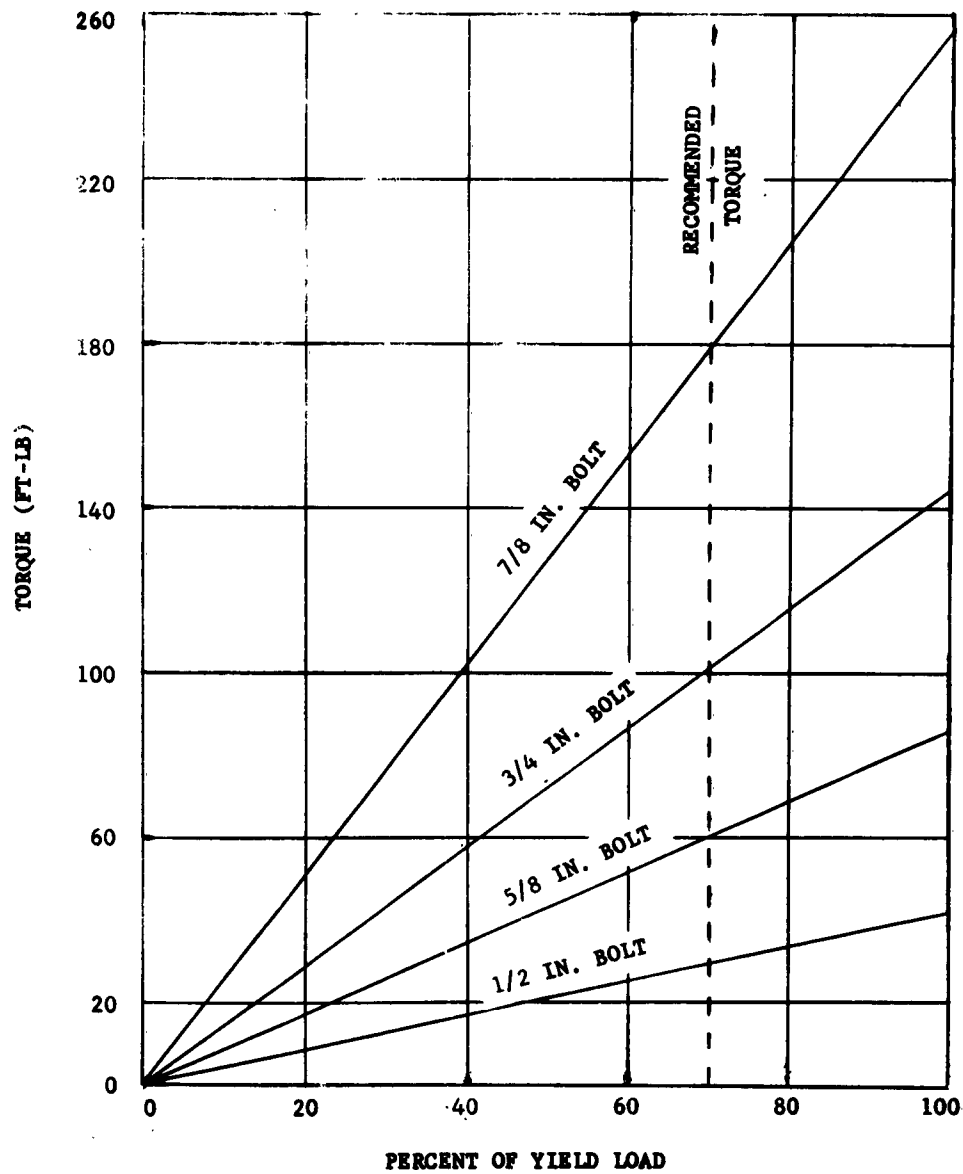

Figure 12. Torque as a Function of Yield Load

5. Valve Flow Coefficients

In order to quickly analyze flow rates in various parts of the PLS, Arthur D. Little, Inc., reduced the flow circuits to equivalent valve flow coefficients (Figures 14 through 18). It was found that these diagrams greatly facilitated the analysis of abnormal flow situations and yielded quick answers regarding the effect of varying the flow parameters. Further, most major valve companies have flow "slide rules" which can be used in conjunction with the figures to obtain quick flow information.

The basis for the charts is the usual definition of valve flow coefficient and the following flow equation:

$$\Delta P = \frac{Q^2 G}{C_v^2}$$

where ΔP = Pressure drop, psi

Q = Flow rate, gallons per minute

G = Specific gravity of fluid (water equals 1.0)

C_v = Valve flow coefficient

The relationships of C_v 's are as follows:

Valves in parallel $C_{v_T} = C_{v_1} + C_{v_2}$

Valves in series $C_{v_T} = \frac{1}{\sqrt{1/C_{v_1}^2 + 1/C_{v_2}^2 + 1/C_v^2}}$

The equivalent valve coefficient of a line was obtained with the following equation (see for an example, Crane Co., Technical Paper 410 entitled, "Flow of Fluids"):

$$C_v = \frac{29.9 d^2}{\sqrt{K}}$$

where: d = pipe diameter, inches

K = impedance, dimensionless

The equivalent valve coefficient for an orifice is obtained from the following formula (when the orifice size is less than one-half the pipe diameter):

$$C_v = 18 (d_o)^2$$

where: d_o = orifice diameter, inches

The flow coefficients were calculated from the above equations and information from the TF-1 PLS configuration as well as actual loading data. The diagrams can also be used for the OBF configuration. The accuracy of the diagrams is estimated to be $\pm 10\%$.

6. VAFB Category II Test Results

During the Category II program at VAFB, five basic items of technical interest concerning the PLS were obtained. These are helium recovery, rapid recycle, minimum levels, loss during standby and helium loading. The first two items are discussed in other sections of this report. The last three items are reviewed here.

a. Minimum-Level Test. The purpose of the minimum level test was to verify the calculated minimum values for load, hold, unload and reload of the several PLS vessels. The results are shown in Table 3.

Table 3

Minimum-Level Test

Vessel	Recommended Minimum (Calculated)	Test Results*			Calculated Post-Test
		Pre-Test	Prior to Unload	Post-Test	
T-201	22,900 gal.	22,900	5000	19,500	18,400
T-401	925 gal.	930	725	700	740
T-402	740 gal.	740	635	640	670
T-301	1,650 psig.	1,700	1325	1,325	850
T-502	600 psig.	2,300	2300	2,300	2,300
T-503	1,700 psig.	1,035	1035	1,035	1,035
T-504	1,900 psig.	1,900	1875	1,325	1,100
T-505	1,100 psig.	1,150	--	N/R	
T-601A	5,500 psig.	5,600	5000	5,000	5,000
T-601B	5,500 psig.	5,600	3775	3,775	4,900

*Data taken from SM-35 Wet CST (LO₂ only) Run I, Part I, 15 August 1962.

The calculated post-test values in Table 3 are based on the actual pre-test commodity levels. They generally agree with the post-test data considering gauge accuracy and readability; however, some differences can be seen in Table 3.

Helium usage (T-601 A and B) was greater than expected, which we believe was due to system leaks. In later tests the helium usage was as predicted. The test results show that the minimum recommended levels are satisfactory.

b. Loss During Standby. The test for loss during standby was run for a 6½-day period during an alert status. Unfortunately, there was not a tight

control over the test during the period and, thus, some of the data obtained are questionable. The data did indicate that the depletion was within tolerance. The calculated allowable depletion is shown in the following table.

<u>Vessel</u>	<u>Allowable Daily Depletion</u>
T-201	66 gal
T-301	4 psi
T-401	16 gal
T-402	12 gal
T-502	15.5 psi
T-503	6 psi
T-504	6 psi
T-505	25 psi
T-601A	6 psi
T-601B	6 psi

3. Helium Loading

Because of the change from aluminum to titanium spheres and from a dual set point for helium loading to a single set point, it was necessary to verify that the amount of helium loaded aboard the missile was sufficient. Therefore, several tests were run to determine the amount of helium loaded aboard the missile. The method used to determine the amount loaded was the sphere lockup method which had proved very successful previously (see Technical Report No. 9).

The results are shown in the following table.

<u>Date of Test</u>	<u>Missile</u>	<u>Amount Loaded (lb)</u>	
		<u>Stage I</u>	<u>Stage II</u>
Test Criteria (from the Martin Co.)		40.44	25.6
13 February 1962	SM-18	40.2	26.5
15 February 1962	SM-18	42.3	27.1
27 August 1962	SM-35	41.4	27.5

For the run on 15 February 1962, an additional three minutes over the normal countdown of cold helium loading took place. On the basis of the above test results, it was decided by others that the helium-load system was meeting the missile criteria.

IV. VISITS AND CONFERENCES

- 9-10 January G. W. Savary visited Vandenberg AFB in connection with the construction of complex 4C-1 at Beale AFB, California.
- 11 January S. S. Waldron and L. E. Kennedy visited Norton AFB for the purpose of discussing contractual problems and propellant loading problems at Larson AFB.
- 14 January W. W. Vicinus visited the Santa Monica office to discuss personnel considerations at Vandenberg AFB.
- 15 January S. S. Waldron, L. E. Kennedy, and D. E. Acker visited Norton AFB for the purpose of discussing contractual problems.
- 22-24 January N. C. Moore visited Lowry AFB for the purpose of acting on a METTS team investigating gasket failure at complex 5A.
- 25 January S. S. Waldron and L. R. McNamee visited Vandenberg AFB to review personnel requirements and to discuss status of PLS work at Vandenberg AFB.
- 28 January S. S. Waldron visited Vandenberg AFB for the purpose of taking care of personnel requirements and to discuss the status of PLS work at Vandenberg AFB.
- 30 January W. G. Pestalozzi visited Norton AFB to serve as an AFBSD consultant at a liquid-sensor meeting.
- 25 February W. W. Vicinus visited the Santa Monica office in preparation for a meeting to be held 26 February 1963 at Norton AFB on Titan I helium leak problems.
- 26 February S. S. Waldron and W. W. Vicinus attended a meeting at Norton AFB for the purpose of discussing Titan I helium leak problems. The meeting was attended by members of BSD-Norton, BSD-Vandenberg, STL-Norton, STL-Vandenberg, SACSO-Norton, SBAMA-Norton, Martin-Denver, Martin-Vandenberg, ADL-Santa Monica, and ADL-Vandenberg.
- 28 February S. S. Waldron attended a meeting at Norton AFB with Major Smothers, BSD, and Al Manassero, ADL Project Officer, on Titan I updating, PLS technical problems, and contract management aspects.
- 6 March S. S. Waldron and J. M. Ruder visited Vandenberg AFB for the purpose of reviewing the rough draft of the Category II Summary Report as well as to discuss data being obtained on helium recovery.

- 11 March D. E. Acker visited Norton AFB to deliver Supplemental Agreement 21.
- 11-15 March W. W. Vicinus assisted the Martin Company in Denver, Colorado, in writing up the Vandenberg Category II Summary Report.
- 12 March S. S. Waldron and N. C. Moore of ADL-Santa Monica, and J. P. Sullivan of ADL-VAFB visited Norton AFB to attend the Third BSD - Industry Safety Management Conference, and to discuss the various technical aspects of our contract with Captain Iten.
- 13 March J. P. Sullivan visited the Santa Monica office to discuss progress on the Vandenberg program.
- 25-29 March W. W. Vicinus assisted the Martin Company in Denver, Colorado, in writing up the Vandenberg Category II Summary Report.

APPENDIX A
ADL CHANGE REQUEST STATUS
WS 107A-2

A. D. LITTLE, INC.
 CHANGE REQUEST STATUS WS 107A-2

DESCRIPTION OF CHANGE	OSTF CRA2-1-X		VAFB TF-1		TH(I) -		LOWRY T-1(2)		ELLSWORTH T-2		MT. HOME T-3		LARSON T-4		BEALE T-5		OBF-CRA2-9-X		
	U	D	U	D	U	D	U	D	U	D	U	D	U	D	U	D	U	D	
PIPE SUPPORTS & ANCHORS FOR LO ₂ PIPING NOT MODIFIED AS PER ADL RECOMMENDATIONS AT DMJM(A) 2/25/55	1	NOT A CHANGE REQUEST																	
DMJM(A) ISOMETRIC PIPING-H.P. GAS DO NOT AGREE, REARRANGEMENT NECESSARY	1	NOT A CHANGE REQUEST																	
MISSILE DISCONNECT (M ₂) IN LATEST DWGS. THESE ARE BEYOND ADL INTERFACE	1	NOT A CHANGE REQUEST																	
VALVES FCV-301, 307, 507, 511 CHANGED FROM ANGLE TYPE-SPLIT BODY TO STRAIGHT THRU-SPLIT BODY	2	A C																	
VALVES FCV-201, 207, 301, 307, 501, 504, 601, 602- ADDED NOTE FOR MOUNTING BRACKET.	2	A C																	
VALVES FCV-105, 107, 203, 204, 205, 207 ADDED NOTE FOR INDIVIDUAL CALIBRATION CURVE OF FLOW/CV	3	A C																	
FOR PRESS. TAPS FOR ORIFICE CONNS & TEMP. CONNS, USE BONNEY THREDOLETS INSTEAD OF COUPLINGS	3	A C																	
DELETE PROCEDURE FOR DRILLING TAPS	3	A C																	
WIRE No. 617- CVG08 CHGD TO 619. ADDED WIRE No 150, 524, 617, 619	4	A C																	
CHANGED VALVE FCV-217 FROM 2" TO 3"	5	D	4	A	A	27	1	A	A	3	A	A	25	1	A	A	25		
CHANGED LOCATION OF VENT VALVE FCV-305	5	A, C																	
INSTALLED LIQ. SENSOR LS-212	5	A, C																	
RELOCATED SAFETY VALVE SV-317	5	D																	

LEGEND:
 D=DISAPPROVED
 A=APPROVED (P)=PARTIAL APPROVAL
 C=CHANGE HAS BEEN MADE
 R=CHANGE WILL BE MADE AFTER FCD

M=MANDATORY
 II=CLASS

ISSUE DATE 4 - 1-63

A. D. LITTLE, INC.
CHANGE REQUEST STATUS WS 107A-2

DESCRIPTION OF CHANGE	OSTF CRA2-1-X		VAFB TF-1		T-1(1)		T-1(2)		ELLSWORTH T-2		MT. HOME T-3		LARSON T-4		BEALE T-5		OBF-CRA2-9-X		
	U	D	U	D	U	D	U	D	U	D	U	D	U	D	U	D	U	D	
ADDED DRAIN PLUGS TO LO ₂ CATCH POTS																			
CHG. FCV-512 TO INCREASE SET PRESS. AND CV																			
RELOCATED SV-336 FROM 4" CSL-204 TO 1/2" CCN-556																			
RELOCATED SV-337 FROM 8" CSL-203 TO 2" CCN-557																			
CORRECTED AIR SUPPLY TO FCV-217 25.0# TO 55#																			
MANUAL VENTS CV120 & CV121 ADDED TO 6" CF-104 & 3" CF-115																			
RELOCATION OF INSTRUMENT COUPLINGS.																			
REVISED SET PRESS. OF SV-308 SV-310, SV-311, SV-312, SV-313, SV-314, SV-315, SV-317, SV-501																			
ADDED SPOOL PIECES FOR FLOWMETERS																			
RESUBMITTED DRAIN PLUGS FOR LO ₂ CATCH POTS																			
REVISED SECT 7A ISSUED SECT 7																			
REVISED SET PRESS. OF SV-205, 310, 311, 312, 313, 314, 315, 317, 326, SV-502, 530, 533, 501, 505.																			
TAPPING INTERFACE REDUCED FROM 6" TO 6"																			

ISSUE DATE 4 - 1 - 63

M = MANDATORY
CO = CHANGE ORDER
II = CLASS

D = DISAPPROVED (P) = PARTIAL APPROVAL
A = APPROVED HAS BEEN MADE
R = CHANGE WILL BE MADE AFTER BOD

LEGEND:

A. D. LITTLE, INC.
 CHANGE REQUEST STATUS WS 107A-2

DESCRIPTION OF CHANGE	OSTF CRA2-1-X			VAFB TE-L			TH (1)			LOWRY T-1(2)			ELLSWORTH T-2			MT. HOME T-3			LARSON T-4			BEALE T-5			OBF-CRA2-9-X					
	U	M	D	U	M	D	U	M	D	U	M	D	U	M	D	U	M	D	U	M	D	U	M	D	U	M	D	U	M	D
CHANGED LINE 6" CSL-216 TO 4" CSL-216																														
ADDED PARAGRAPH DESCRIBING INSTR. TAPS																														
REVISED EVAPORATION LOSS-LO ₂ STORAGE TANK																														
REVISED RP-PAINTING - LO ₂ STORAGE TANK																														
REVISED EVAP LOSS TEST-LO ₂ STORAGE TANK																														
DELETED CHARPY IMPACT-LO ₂ STORAGE TANK																														
REVISED RP-INNER VESSEL SUSPENSION																														
REVISED RP-CORROSION ALLOWANCE																														
LESS-LO ₂ TANK-12" TO 9" EXTENSION																														
CHGD. FLANGE, MATL. FROM 304 TO 316 & 347 (2500#)																														
REROUTE & RENAME 511 & 581																														
CV RATINGS ON FCV111, FCV604																														
ADD LO ₂ FILTER-F-206 & FUEL FILTER F-105 <small>ONLINE</small>																														

ISSUE DATE 4 - 1 - 63

M = MANDATORY
 W = WITHDRAWN
 II = CLASS

D = DISAPPROVED (P) = PARTIAL APPROVAL
 A = APPROVED HAS BEEN MADE
 C = CHANGE WILL BE MADE AFTER 800

LEGEND:

A. D. LITTLE, INC.
CHANGE REQUEST STATUS WS 107A-2

DESCRIPTION OF CHANGE	OSTF CRAZ-1-X		VAFB TF-1		LOWRY T-1(I)		T-1(2)		ELLSWORTH T-2		MT. HOME T-3		LARSON T-4		BEALE T-5		OBF-CRAZ-9-X	
	MADE	DATE	MADE	DATE	MADE	DATE	MADE	DATE	MADE	DATE	MADE	DATE	MADE	DATE	MADE	DATE	MADE	DATE
GENERAL COMMENT ON OSTF SPECS	24	NOT ISSUED																
ELIMINATION OF CASE PROVIDED IN INSTRUMENT CIRCUITS	22	A A C			12	A A	12	A A										
WELDING & FABRICATION SPECIFICATION OF PROCESS PIPING			12	A A	12	A A												
DELETION OF LINE 553 & CV-541			7	A A	7	A A												
DELETE GS-201, 203, 204 AND 205. CHANGE RADIO OF VS-201, 203 AND 205 TO 1-100 PSI.			14	A A	14	A A												
CHANGE PRV-701 SIZE & FLOW RATE			16	A A	16	A A												
REVISED SECTIONS ON INSTALLATION, TESTING, AND CLEANING SPECIFICATIONS			15	Superseded by AZ-2-15														
ADD LIQUID SENSOR LS-103	20	A A C																
DELETE VENT LINES 516, 577, 578, 579, 589, 591, 592, 593, 597 AND FCV-503	26	A A C																
REROUTE LINE 2"-J5N-511	27	A A C																
ADD 28 VOLT 10 WATT AUX. MOTOR CONTROL RELAY	25	A A	17	A A	17	A A												
REVISED AND RESUBMITTED AZ-2-5 WITH ADDITION OF 1600 # N ₂ SERVICE AT -96 F ^o C.			16	A A	16	A A												
REVISED AND RESUBMITTED AZ-2-15 (T, P, T ONLY)			18	A A	18	A A												

LEGEND:
 D=DISAPPROVED (P)=PARTIAL APPROVAL
 A=APPROVED HAS BEEN MADE
 C=CHANGE WILL BE MADE AFTER BOD
 R=CHANGE WILL BE MADE AFTER BOD
 M=MANDATORY
 II=CLASS
 ISSUE DATE
 4-1-63

A. D. LITTLE, INC.
CHANGE REQUEST STATUS WS 107A-2

DESCRIPTION OF CHANGE	OSTF CRA2-1-X		VAEB TF-1		T-1(1)		T-1(2)		ELLSWORTH T-2		MT. HOME T-3		LARSON T-4		BEALE T-5		OBF-CRA2-9-X			
	DATE	STATUS	DATE	STATUS	DATE	STATUS	DATE	STATUS	DATE	STATUS	DATE	STATUS	DATE	STATUS	DATE	STATUS	DATE	STATUS		
ISSUED ACCEPTANCE TEST SPECIFICATIONS	19	A	162	A	21	A	156	A	21	A	145	A	12	NOT ISSUED	8	A	9	NOT ISSUED		
CHANGE FLOW DATA ON VALVE FCV-503	23	A	199	A	19	A	100	A	19	A	100	A	2	A	1	A				
REVISED SECTION ON CLEANING, PROPELLANT LOADING SYSTEM	23	A	78	A	19	A	100	A	19	A	100	A	2	A	1	A				
DELETE WIRING AND CONDUIT RELATED TO FCV-503 (SEE A2-1-26)	25	A	88	A	22	P	100	A	22	P	100	A	7	A	9	NOT ISSUED				
ADDITION OF STRAINER TO STANDARDIZED EQUIPMENT LIST	25	A	88	A	22	P	100	A	22	P	100	A	7	A	9	NOT ISSUED				
INNER VESSEL SUSPENSION DELETION OF REFERENCE TO 3 POINT SUSPENSION	25	A	88	A	22	P	100	A	22	P	100	A	7	A	9	NOT ISSUED				
INSTRUMENT CONNECTIONS PS-201, 202, 203, 204, 206, 301, PS-601, 602	24	A	115	A	20	A	100	A	20	A	100	A	8	A	5	A	5	A	5	A
CHANGES TO LINE DESIGNATION TABLE	31	NOT	151	A	24	A	100	A	24	A	100	A	20	A	20	A	20	A	20	A
SPECIFIED CV OF REDEFINE LOW PRESS N2 PIPING	32	NOT	151	A	24	A	100	A	24	A	100	A	20	A	20	A	20	A	20	A
REDEFINE FITTINGS FOR CLASS	33	NOT	151	A	24	A	100	A	24	A	100	A	20	A	20	A	20	A	20	A
ADDITION OF PARAGRAPH 40B-04, 4-4 05, & ON SOLDER ALL THREAD JOINTS	27	ISSUED	151	A	24	A	100	A	24	A	100	A	20	A	20	A	20	A	20	A
CORRECTION OF LO2 & H6 SUBCOOLER VACUUM TEST PRESSURE	22	A	104	A	23	A	104	A	23	A	104	A	5	A	3	A	3	A	3	A
REVISE SPEC TO EXPLICITLY CALL FOR TWO (108 CWFT) 16A STORAGE	23	D	104	A	23	A	104	A	23	A	104	A	5	A	3	A	3	A	3	A
REVISE PORT OPENING FROM 5/16" TO 3/32" ON CUI-503, 502, 503, 504, 505, 506, 509, 601, 602, 605	23	D	104	A	23	A	104	A	23	A	104	A	5	A	3	A	3	A	3	A

ISSUE DATE

D = DISAPPROVED
A = APPROVED (P) = PARTIAL APPROVAL
C = CHANGE HAS BEEN MADE
R = CHANGE WILL BE MADE AFTER 80D

M = MANDATORY
II = CLASS

A.D. LITTLE, INC.
CHANGE REQUEST STATUS WS 107A-2

DESCRIPTION OF CHANGE	OSTF CRA2-1-X		VAFB TF-1		LOWRY T-1(1)		T-1(2)		ELLSWORTH T-2		MT. HOME T-3		LARSON T-4		BEALE T-5		OBF - CRA2-9-X	
	CR	DATE	CR	DATE	CR	DATE	CR	DATE	CR	DATE	CR	DATE	CR	DATE	CR	DATE	CR	DATE
INSERT PARA ON HYDROSTATIC TESTING OF PLS PIPING SECTIONS			25	3/31	26	3/31	26	3/31	9	A D	4	A D	6	A D				
LS-212 ADDED TO PIPING & ELECTRICAL DWGS; RELOCATE FCV-305 ON ELECTRICAL DWGS			25	3/31	26	3/31	26	3/31	9	A D	4	A D	6	A D				
DELETE SV-521 AND LINE CSN -555			25	3/31	26	3/31	26	3/31	9	A D	4	A D	6	A D				
RELOCATE PRESSURE TAP FOR PS-516 & PI-516			27	5/19	27	5/18	27	5/18										
DELETED SOV-507A INSERTED FOUR WAY HAND VALVE CVI-520			27	5/19	27	5/18	27	5/18										
VOLUTE VENT PIPING & VALVE ADDED TO P-20V(L ₂) UNLOADING HWS			27	5/19	27	5/18	27	5/18										
REROUTE LINES 507, 509, 527, 530, 503, 548, ADD LINE 519, 520, 521, 522, 523, 524, 525, 526, 527, 528, 529, 530, 531, 532, 533, 534, 535, 536, 537, 538, 539, 540, 541, 542, 543, 544, 545, 546, 547, 548, 549, 550, 551, 552, 553, 554, 555, 556, 557, 558, 559, 560, 561, 562, 563, 564, 565, 566, 567, 568, 569, 570, 571, 572, 573, 574, 575, 576, 577, 578, 579, 580, 581, 582, 583, 584, 585, 586, 587, 588, 589, 590, 591, 592, 593, 594, 595, 596, 597, 598, 599, 600, 601, 602, 603, 604, 605, 606, 607, 608, 609, 610, 611, 612, 613, 614, 615, 616, 617, 618, 619, 620, 621, 622, 623, 624, 625, 626, 627, 628, 629, 630, 631, 632, 633, 634, 635, 636, 637, 638, 639, 640, 641, 642, 643, 644, 645, 646, 647, 648, 649, 650, 651, 652, 653, 654, 655, 656, 657, 658, 659, 660, 661, 662, 663, 664, 665, 666, 667, 668, 669, 670, 671, 672, 673, 674, 675, 676, 677, 678, 679, 680, 681, 682, 683, 684, 685, 686, 687, 688, 689, 690, 691, 692, 693, 694, 695, 696, 697, 698, 699, 700, 701, 702, 703, 704, 705, 706, 707, 708, 709, 710, 711, 712, 713, 714, 715, 716, 717, 718, 719, 720, 721, 722, 723, 724, 725, 726, 727, 728, 729, 730, 731, 732, 733, 734, 735, 736, 737, 738, 739, 740, 741, 742, 743, 744, 745, 746, 747, 748, 749, 750, 751, 752, 753, 754, 755, 756, 757, 758, 759, 760, 761, 762, 763, 764, 765, 766, 767, 768, 769, 770, 771, 772, 773, 774, 775, 776, 777, 778, 779, 780, 781, 782, 783, 784, 785, 786, 787, 788, 789, 790, 791, 792, 793, 794, 795, 796, 797, 798, 799, 800, 801, 802, 803, 804, 805, 806, 807, 808, 809, 810, 811, 812, 813, 814, 815, 816, 817, 818, 819, 820, 821, 822, 823, 824, 825, 826, 827, 828, 829, 830, 831, 832, 833, 834, 835, 836, 837, 838, 839, 840, 841, 842, 843, 844, 845, 846, 847, 848, 849, 850, 851, 852, 853, 854, 855, 856, 857, 858, 859, 860, 861, 862, 863, 864, 865, 866, 867, 868, 869, 870, 871, 872, 873, 874, 875, 876, 877, 878, 879, 880, 881, 882, 883, 884, 885, 886, 887, 888, 889, 890, 891, 892, 893, 894, 895, 896, 897, 898, 899, 900, 901, 902, 903, 904, 905, 906, 907, 908, 909, 910, 911, 912, 913, 914, 915, 916, 917, 918, 919, 920, 921, 922, 923, 924, 925, 926, 927, 928, 929, 930, 931, 932, 933, 934, 935, 936, 937, 938, 939, 940, 941, 942, 943, 944, 945, 946, 947, 948, 949, 950, 951, 952, 953, 954, 955, 956, 957, 958, 959, 960, 961, 962, 963, 964, 965, 966, 967, 968, 969, 970, 971, 972, 973, 974, 975, 976, 977, 978, 979, 980, 981, 982, 983, 984, 985, 986, 987, 988, 989, 990, 991, 992, 993, 994, 995, 996, 997, 998, 999, 1000																		
INSTALL SHIELD PLATE IN LO ₂ VENT SHAFT			27	5/19	27	5/18	27	5/18										
RELOCATE LINE 569 RELOCATE STAND FOR LS-201 DELETE STAND FOR LS-202			27	5/19	27	5/18	27	5/18										
ADDED PLATE IN NEAR CV-311 IN PRAP. TERM.			27	5/19	27	5/18	27	5/18										

LEGEND
 D = DISAPPROVED
 A = APPROVED (P) = PARTIAL APPROVAL
 C = CHANGE HAS BEEN MADE
 R = CHANGE WILL BE MADE AFTER BOD

M = MANDATORY
 II = CLASS

ISSUE DATE
 4 - 1 - 63

ARTHUR D. LITTLE INC.
CHANGE REQUEST STATUS WS 107A-2

DESCRIPTION OF CHANGE	E.F.F.	FCR NO.	DATE	ACTION	VAFB		LOWRY		ELLSWORTH		MT. HOME		LARSON		BEALE	
					TBF	TF-1	T-1(1)	T-1(2)	T-2	T-3	T-4	T-5				
					MOD NO	DATE	MOD NO	DATE	MOD NO	DATE	MOD NO	DATE	MOD NO	DATE	MOD NO	DATE
REVISION TO CALL FOR STRANDED WIRE ON P.L.S.	10/5	01	6/23/60	C												
INSTALL LO2 DRAIN FILTER F206	2/5	02	6/29/60	A					47		15		38			77
ADD TEE'S TO VENT PIPING	TF-1	03	9/13/60	A												
REISSUE OF ADL-RB BY ADL/FO	TF-1	03	9/15/60	A	192											
ADD INSECT SCREEN TO VENT TUNNEL	10/5	04	7/13/60	A					48							
ADD BLEED VALVES TO LINES	10/5	05	10/18/60	A												
REISSUED ADL-OS TO ADD B/V TO LINES	10/5	05	11/17/60	A												
ADD DRAIN LINES TO T-203 & 202	TF-1	06	1/14/61	A												
RELOCATED LLT-201 INSTRUMENT CONNEX.	TF-1	07	1/29/61	A												
ADD ORIFICE PLATES OF-206, 208 & 209	TF-1	08	1/29/61	A												
BYPASS LINE & VALVE FOR LO2 SUBCOOLER	TF-1	09	3/24/61	A												
R-21 ST. FLANGE DUST PROTECTOR	TF-1	10	3/21/61	D												
PRESSURE EQUALIZING LINE - LO2 SUBCOOLER	TF-1	11	3/24/61	D												
AD-LOG REISSUED FOR TESTS @ TF-1	TF-1	12	4/21/61	A												
INCREASE RANGE OF PC-512 & PI-511	TF-1	13	4/19/61	A												
REPAIR OR REPLACE SAFETY VALVES	TF-2	14	5/31/61	A												

LEGEND: A = APPROVED
D = DISAPPROVED

ARTHUR D. LITTLE INC.
CHANGE REQUEST STATUS WS 107A-2

DESCRIPTION OF CHANGE	E F F.	FCR NO.	DATE	ACTION	VAFB		LOWRY		ELLSWORTH		MT. HOME		LARSON		BEALE	
					TBF	TF-1	T-1(1)	T-1(2)	T-2	T-3	T-4	T-5				
					DATE	MOD NO	DATE	MOD NO	DATE	MOD NO	DATE	MOD NO				
NAMEPLATE NOMENCLATURE	TF-1	015	8/29/62	A												
REPLACEMENT OF GAGE SAVER-GS-502	TF-1	016	12/19/61	A												
CHANGE SETTING OF PC-512 FPS-511	T-10	017	12/14/61	A												
P-201 FOUNDATION STIFFENING	TF-1	018	12/18/61	A	D											
P-201 FOUNDATION STIFFENING	T-10	019	12/13/61	A	D											
P-201 MOUNT STIFFENING	T-2	020	12/19/61	A	D											
MODIFICATION OF FILTERS F-201 & 205	TF-1	021	1/11/62	A	D											
ADDITIONAL PLS SUPPORTS & MODE	T-2	022	1/14/62	A	A											
EXTENDS EFFECTIVITY TO L-2 & 3 AT TF-1	TF-1	012	1/11/62	A	A											
EXTENDS EFFECTIVITY TO OPERATIONAL BASE	T-2	017	1/11/62	A	A											
LIQUID SENSORS; INTERIA FIX	T-1	027	2/11/62	A	A											
LIQUID SENSORS; INSTALLATION REQUIRE.	T-1	024	2/19/62	A	A											
LIQUID SENSORS; PROBE MODIFICATION	T-1	025	2/23/62	A	A											
SINGLE SET POINT	TF-1	026	3/30/62	SUPERSEDED												
LOADING TEST PROGRAM	TF-1	027	3/13/62	D	A											
REVISE SETTINGS OF PC-512 & PS-511	T-5	027	3/13/62													
PROBE MODIFICATION; INSTALLATION; AID	T-1	025	3/14/62													

LEGEND: A = APPROVED
D = DISAPPROVED

