

UNCLASSIFIED

AD 410320

DEFENSE DOCUMENTATION CENTER

FOR

SCIENTIFIC AND TECHNICAL INFORMATION

CAMERON STATION, ALEXANDRIA, VIRGINIA



UNCLASSIFIED

NOTICE: When government or other drawings, specifications or other data are used for any purpose other than in connection with a definitely related government procurement operation, the U. S. Government thereby incurs no responsibility, nor any obligation whatsoever; and the fact that the Government may have formulated, furnished, or in any way supplied the said drawings, specifications, or other data is not to be regarded by implication or otherwise as in any manner licensing the holder or any other person or corporation, or conveying any rights or permission to manufacture, use or sell any patented invention that may in any way be related thereto.

N-63-4-3

**US ARMY
ELECTRONICS
RESEARCH & DEVELOPMENT
ACTIVITY**

CATALOGED BY DDC

AS AD No.

410320

INTERPRETING THE IRIG STANDARDS FOR PAM/FM TELEMETRY

BY

ROBERT C. BARTO

410320

USA ERDA-23

MAY 1963

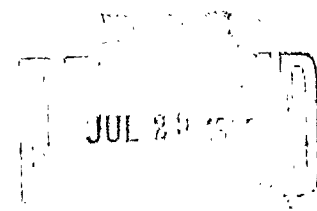

**WHITE SANDS MISSILE RANGE
NEW MEXICO**

INTERPRETING THE IRIG STANDARDS FOR PAM/FM TELEMETRY

BY

ROBERT C. BARTO

USA ERDA-23

MAY 1963

DA Project 1-G-2-50206-D241

INSTRUMENTATION DEPARTMENT
U. S. ARMY ELECTRONIC RESEARCH AND DEVELOPMENT ACTIVITY
WHITE SANDS MISSILE RANGE
NEW MEXICO

HEADQUARTERS
U. S. ARMY ELECTRONICS RESEARCH AND DEVELOPMENT ACTIVITY
WHITE SANDS MISSILE RANGE
NEW MEXICO

May 1963

1. Technical Report USA ERDA-23 has been prepared under the supervision of the Instrumentation Department and is published for the information and guidance of all concerned.

2. Suggestions or criticisms relative to the form, contents, purpose, or use of this publication should be referred to the Commanding Officer, U. S. Army Electronics Research and Development Activity, ATTN: SELWS-E, White Sands Missile Range, New Mexico.

FOR THE COMMANDER:



L. W. ALBRO
Major, AGC
Adjutant

U. S. ARMY ELECTRONICS RESEARCH AND DEVELOPMENT ACTIVITY
WHITE SANDS MISSILE RANGE
NEW MEXICO

WILLIAM G. SKINNER
COLONEL, SIGNAL CORPS
COMMANDING

Approval. Technical Report USA ERDA-23 has been reviewed and approved
for publication:



PAUL R. SMOR
Capt, SigC
Director
Instrumentation Department

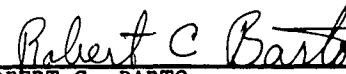

ROBERT C. BARTO
Chief
Telemetry Systems Division

Distribution. This report has been distributed in accordance with
SELWS-E List Nr. 1 and Special. Initial Printing 200 copies.

DDC Availability Notice. Qualified requesters may obtain copies of
this report from DDC.

A B S T R A C T

Knowledge of the technical basis underlying the particular choice of parameters, quantities, and configurations specified in the Telemetry Standards could lead to the more effective use of the document. During the preparation phase, such technical information is assembled to form the basis of the Standard. Although there was no attempt to preserve or organize such information during the recent preparation of the Standard for PAM/FM Telemetry, some of this material is available and is drawn upon to discuss interesting sections of the Standard.

C O N T E N T S

	<u>PAGE</u>
ABSTRACT -----	iii
INTRODUCTION -----	1
PAM/FM STANDARDS -----	2
Selection of Parameters -----	2
Sampling Rate Stability -----	7
Frame and Pulse Structure -----	7
Synchronization -----	7
Pre-Modulation Filter -----	9
CONCLUSION -----	10
REFERENCES -----	11

I N T R O D U C T I O N

The Telemetry Working Group (TWG) of the Inter-Range Instrumentation Group (IRIG) has recently completed a large scale revision of IRIG Document 106-60, "Telemetry Standards." This revision included the addition of a new standard, PAM/FM Telemetry, which now appears as Part IV of the document. Many of the people involved in this work are convinced that improved communications between the elements of the telemetering community, while standards are being prepared and after they are published, will result in both better standards and more willing acceptance of them. The standards must, of course, reflect the needs and capabilities of the technology. The technical people involved in the design, development, and use of telemetry systems must be assured that the particular choice of parameters and quantities is not capricious.

The Telemetry Working Group has established effective communications within the technology during the preparation phase of standards. Technical representatives from industrial, governmental, and professional organizations are invited to participate in open meetings sponsored by the working group in which each section of the proposed standard is discussed in detail. After the meeting, a revised draft of the standard is mailed to all attendees and to others who may be interested for additional comment. The draft is also reviewed by professional and industrial groups such as the Telemetry Standards Coordination Committee (TSCC), the Aerospace Industries Association (AIA), the Institute of Electrical and Electronic Engineers (IEEE), etc.

Communications after the standard is published, however, can be very much improved. Everyone within the technology needs to have access to the technical information that led to the choice of each parameter and quantitative limitation in the document. At the time standards are drafted, this information, which becomes the technical foundation upon which the document is based, is on hand in various degrees of organization. It can and should, I believe, be preserved and made available to everyone who has occasion to use the standard. A first step in this direction was made in the original IRIG Document 106-60 by including some information in an appendix and a glossary. Additional information of this type could be placed in the appendices of future standards or contained in an interpretive supplement.

During the preparation of the new PAM/FM Standard, no real effort was made to preserve or organize for publication technical information of the type discussed. Some of this material is, however, still available and will be the subject of this paper.

PAM/FM STANDARDS

SELECTION OF PARAMETERS

In the preparation of Telemetry Standards, the parameters to be standardized are selected to achieve the objectives of the program. These objectives certainly include the assurance that the system will perform reliably and efficiently and that the variety of airborne and ground equipment be kept within reasonable bounds. In the case of the PAM/FM Standard, the parameters selected for standardization are:

1. Receiver design i-f bandwidth, B.
2. Frequency deviation, peak, F_{DP} .
3. Sampling rate stability.
4. Frame structure.
5. Pulse duty cycle.
6. Synchronization.
7. Commutation.
8. Radiated spectrum.
9. Modulation.

At this point, it is necessary to distinguish between the new PAM/FM Standard which appears as Part IV of IRIG Document 106-60 and the older PAM/FM/FM Standard, PAM on a subcarrier, which appears in Section 2.4 of the document. Part IV describes a newly standardized service that is intended to supplement Section 2.4 by providing for PAM on an r-f carrier with a capability for greatly increased pulse rates.

Receiver design i-f bandwidths are specified so that the missile test ranges need only be prepared to accommodate the eight values ranging from 12.5 kc to 1.5 Mc listed in Table IV of the Standard. The designer is given maximum latitude in the choice of a sampling rate. He chooses from a continuum of rates to meet his particular project requirements. The chosen rate is then optimally related to one of the specified receiver i-f bandwidths through the peak deviation, F_{DP} , and permissible total residual error. The relationship between the ratio of receiver i-f bandwidth and total rms error, B/f_s , is discussed at length by Drs. Myron L. Nichols and L. L. Rauch^{1,2} and in the Aeronutronic Telemetry Study Reports^{3,4}. Figure 4 of the IRIG Document 106-60, revised, was prepared by Aeronutronic as a result of the latter study and depicts this relationship. The Figure is reproduced in this paper as Figure 1 for convenience. Background information relating to the chart itself is found in Section 6 of Reference 3.

To select the optimum bandwidth for a particular project, the designer starts with the number of channels to be sampled and the frequency response of the individual channels. An appropriate number of samples per cycle of information is then chosen to bring aliasing error within accuracy requirements^{5,6}. The total sampling rate is now established. The next step is to choose a B/f_s ratio by reference to the chart in Figure 4 of the Standard (Figure 1) which will hold crosstalk and other error within a tolerable level. The chart is entered with the total rms error that can be tolerated, and the factor B/f_s is read directly. The values read from the curve are minimum values required to limit total residual (system) error to the indicated level. Use of higher B/f_s ratios effectively increases additive noise and raises the receiver threshold but decreases crosstalk. Since f_s is fixed by the project requirements, B may now be determined by applying the B/f_s factor.

$$\text{Let } M_1 = B/f_s;$$

then,

$$B = M_1 f_s.$$

The receiver design i-f bandwidth, B , is now specified. The peak-to-peak deviation which, by Section 4.2.2 of the Standard may not exceed $0.75 B$, now has an upper limit. The designer may now select an appropriate video bandwidth, B_v , a parameter not covered in the Standard, which meets his crosstalk requirements. Figure 6.2.4 of Reference 2 and Figures II-6-1 through II-6-10 (in Reference 3) relate crosstalk attenuation, rms error, and input signal-to-noise ratios to B_v/f_s .

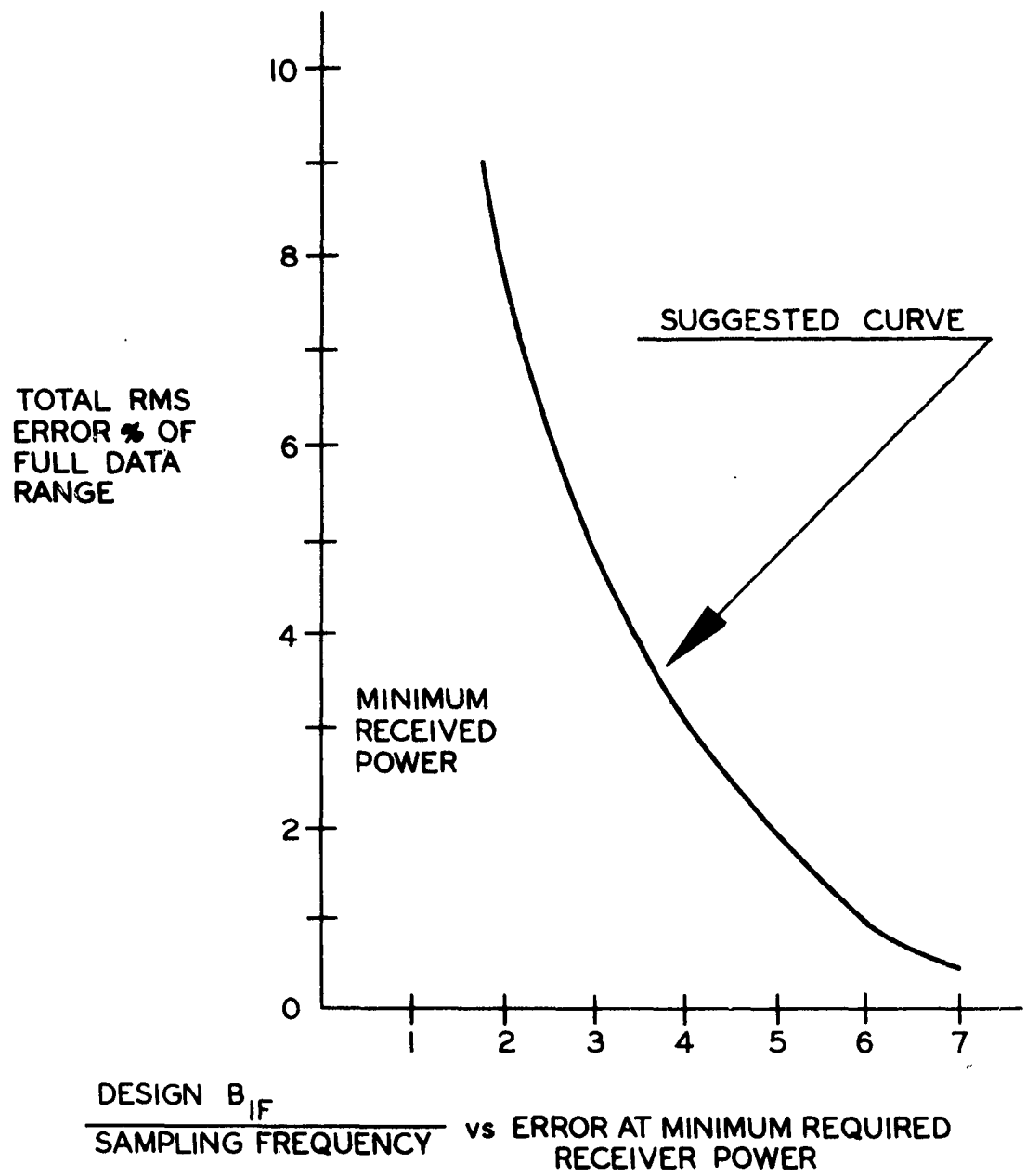

FIGURE 1.

Nominal values range from just under one to two or more depending upon tolerable error, gatewidth, peak deviation, and so forth.

To proceed from the receiver design i-f bandwidth to the actual receiver bandwidth, it is necessary to consider the frequency instability of the system, including transmitter instability, T_s , receiver instability, R_s , and doppler shift, D_s . The combined instability, C_s , may be calculated as follows⁷:

$$C_s = \sqrt{(T_s)^2 + (R_s)^2 + (D_s)^2} .$$

This roughly corresponds to the standard deviation of the signal about its assigned frequency. Assuming operation at the lower end of the VHF bandwidth with available equipment (transmitter instability of 0.01 per cent and receiver instability of 0.005 per cent) and a vehicle radial velocity of 5,000 mph,

$$\begin{aligned} C_s &= \sqrt{(225 \times 10^6 \times 10^{-4})^2 + (225 \times 10^6 \times 5 \times 10^{-5})^2} \\ &= 25,200 \text{ cps,} \end{aligned}$$

including the inaccuracy of the basic crystal frequency. Since the composite shift may occur in either a positive or negative direction, the additional receiver bandwidth required to contain the signal is

$$2C_s = 50.4 \text{ kc.}$$

It can be argued that it is more realistic to consider Doppler shift as an absolute value. Then

$$C_s = \sqrt{(T_s)^2 + (R_s)^2} + D_s .$$

In the example cited and most practical situations, however, the effect is small. It is worth noting that the shift may not always have the negative sign of a receding vehicle.

A conservative design may even require that the instabilities be combined as absolute quantities. Then in the case cited,

$$\begin{aligned}
T_s &= f_0 \pm 0.01 \text{ per cent,} \\
R_s &= f_0 \pm 0.005 \text{ per cent, and} \\
C_s &= f_0 \pm 0.015\% \pm D_s \\
&= 2.25 \times 10^8 \times 1.5 \times 10^{-4} \pm D_s \\
&= \pm 33,750 \pm 3360 \text{ cps} \\
&= \pm 37.1 \text{ kc}
\end{aligned}$$

where f_0 is the assigned carrier frequency. On this basis, the total receiver bandwidth, $B_{(\text{actual})}$ requirement is approximately

$$B_{(\text{actual})} = B + 2C_s$$

if the vehicle is to be tracked both approaching and receding from the ground station. In the example given above,

$$B_{(\text{actual})} = B + 74.2 \text{ kc .}$$

The use of tracking filters or automatic frequency control (AFC) will reduce the actual i-f bandwidth requirements to some extent. In any case, the engineer must consider all of these factors in choosing an appropriate i-f band shift factor ranging from 1.5 to 3.3 to apply to the design i-f bandwidth to obtain the actual receiver bandwidth. A sufficient number of bandwidths is specified in Table IV of the Standard so that the calculated value must fall reasonably close to a standard value. Within the restriction that the peak-to-peak deviation may not exceed $0.75 B$, transmitter deviation may be adjusted to aid in tailoring the transmitted signal to one of the specified actual receiver bandwidths.

This is essentially the process of moving from the channel requirements and the frequency response of each channel to the selection of a receiver i-f bandwidth which will contain the transmitted signal under the assumed operating conditions. The transmitter and receiver instabilities used in the examples are those specified in Appendix I of IRIG Document 106-60 for VHF operation.

The receiver bandwidths specified in Table IV of the Standard were selected to include existing receiver bandwidths of 100 kc, 300 kc, and 500 kc for reasons of economy. Bandwidths above and below these values were assigned at convenient intervals.

SAMPLING RATE STABILITY

Sampling rate stability, as specified, assumes the use of mechanical commutation for most applications at the lower pulse rates. The stability specified is, therefore, well within the state-of-the-art. The stability and pulse jitter tolerance statements refer to a consecutive number of samples N "where N is the number of samples closest to 1000 within an integral number of frames." The maximum number of channels in a PAM frame is specified as 130. Therefore, N is specified as

$$870 < N < 1130.$$

FRAME AND PULSE STRUCTURE

Members of the Telemetry Working Group are somewhat sensitive to questions relating to the number of primary channels specified for PCM and extended to PAM. Any discussion of this section inevitably leads to the observation that electronic logic devices are composed of binary elements. Hence, the number of primary channels should be specified as either 128 or 256. From a logical element point of view, the 130 figure is indefensible. However, the number represents a compromise between mechanical and electronic commutators and a desire to keep the total number of primary channels within reasonable limits. In the PCM case, the number selected is compatible with the maximum number (2048) of bits per frame allowed and an average word length of 15 bits. There is some advantage in keeping all time multiplex systems compatible in this respect. Otherwise, the frame and pulse structure specified is straightforward.

SYNCHRONIZATION

The synchronization patterns permitted for PAM/FM include the conventional scheme of three adjacent channels deviated to the maximum signal level to identify the frame. In the 50 per cent duty cycle case, 20 to 25 per cent of the channel deviation is reserved for channel synchronization. Channel synchronization is derived from the varying amplitudes normally encountered from channel to channel in progressing through the frame in the 100 per cent duty cycle systems. Frame identification cannot be unique, however, in the latter configuration unless a coded pattern is transmitted, since the data is permitted to occupy all levels within the deviation range. Incidentally, Figure 5 C on Page 16 of the Standard is in error and will be corrected at the next printing. The Figure erroneously shows minimum data level occurring approximately 25 per cent above the lower deviation limit. This would, of course, provide a unique synchronization pattern, but it is not correct. Figure 2 shows the correct waveform.

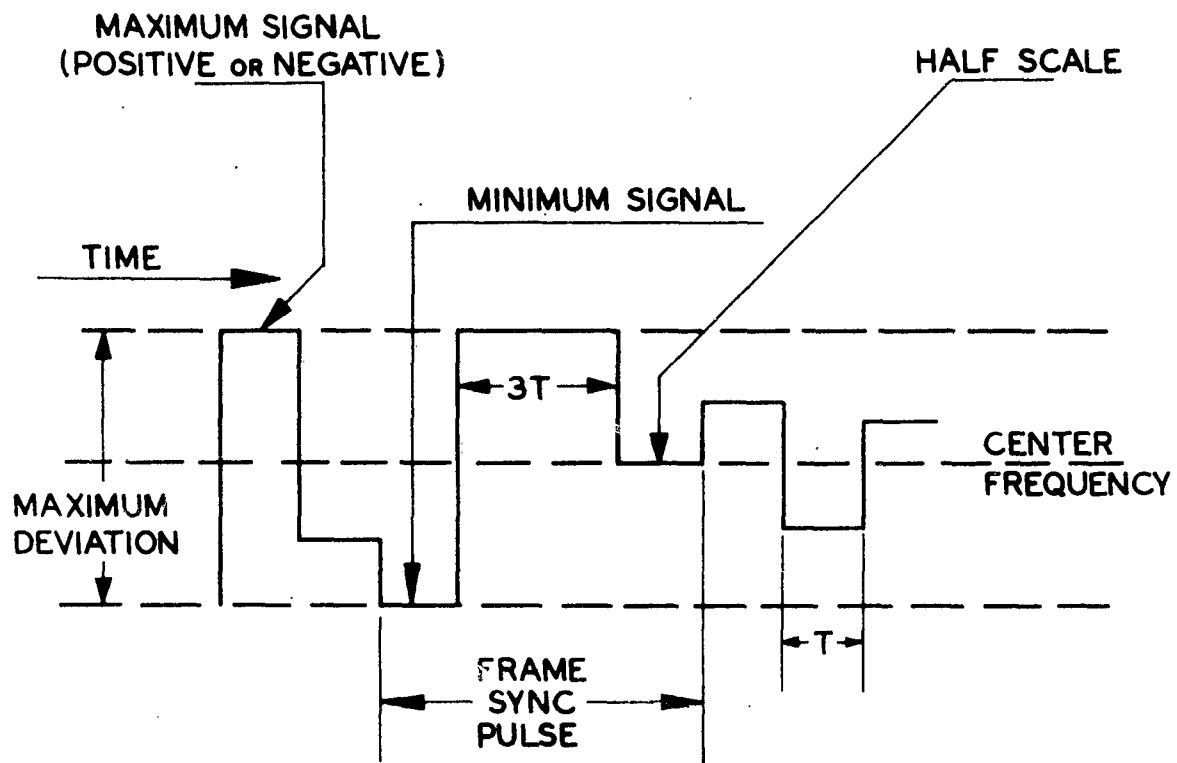

PAM PULSE TRAIN WAVEFORM, CONVENTIONAL
FRAME SYNCHRONIZATION 100 PERCENT DUTY
CYCLE

FIGURE 2

A unique pattern is possible if the PAM pulse rate is increased by a factor of 2, 3, 4, etc. in the frame identification period. This technique assures that transitions will occur at least one in each frame and, in addition, provides a pulse pattern that cannot occur within the data to uniquely identify the frame. The use of logical elements to identify the coded pulses is unnecessary since they are easily identified by the rate.

Section 4.5 of the Standard describes the synchronization patterns permitted and limits the number of coded pulses which may occupy a single PAM pulse period to seven. It further requires that the coded pulses shall evenly divide the PAM pulse sample period. The maximum number of coded pulses is derived from the last sentence of the section which reads, "The minimum duration of the pulses comprising the coded word is defined as 1/M times the data sampling period, where M is the largest integer not in excess of the design i-f bandwidth divided by the total sampling rate." In other words,

$$M_{(\text{integer}) \text{ max}} \leq \frac{B}{f_s} .$$

However, a more practical value for M would be 2, 3 or 4.

Permission to use coded frame identification patterns in the PAM format has probably generated more comment than all other sections of the Standard combined. So much comment indicates that the function of this section was not made clear at the time the Standard was prepared. There are advantages to the use of these patterns. By this simple device, a unique synchronization pattern is available to identify the frame in 100 per cent duty cycle systems at the expense of a relatively few channel intervals. The equipment complication is slight. It is, after all, the only way in which a unique pattern can be obtained without restricting the deviation range of the data signal. It should be extremely valuable in identifying the subcommutated frame.

PRE-MODULATION FILTER

The use of pre-modulation filtering is required by the standard to conserve the r-f spectrum. Although no specific roll-off is stated for the filters, the appendices contain a recommendation that the total attenuation of the filter plus modulator and transmitter be 36 db per octave beyond the design i-f bandwidth. The factors to be considered in the selection of a pre-modulation filter are those which influenced the choice of the video bandwidth. Other factors must also be

considered, including those of crosstalk and total system error. Optimum operation results when the overall frequency response of the transmitter modulation matches that of the receiver video stage. The response of this complete circuit and that of the receiver i-f amplifier establish the levels of crosstalk and, to a large degree, total system error of the telemeter. A reasonable approach, then, to the selection of a pre-modulation filter is to choose a receiver video bandwidth compatible with crosstalk tolerance as previously described and then match the modulator characteristics to it with a suitable pre-modulation filter.

C O N C L U S I O N

The sections of the PAM Standard discussed in this paper are those which generated the most comment throughout the industry during the preparation phase and immediately following publication. It is hoped that the additional information contained in this paper conveys some of the consideration that went into the generation of the PAM/FM Standard.

R E F E R E N C E S

1. Nichols, M. H., "Comparison of PAM and PCM," Research Report, Instrumentation Engineering Program, University of Michigan, USAF Contract No. AF 33 (616)-5796, Task #82048, Project No. 4107, 28 Feb 1961.
2. Nichols, M. H., and Rauch, L. L., "Radio Telemetry," Wiley (1956).
3. "Telemetry System Study, Final Report Volume II," Aeronutronic Publication U-743, 18 Dec 1959.
4. "Telemetry System Study, Final Report Volume I," Aeronutronic Publication U-743, 18 Dec 1959.
5. "Interpolation Errors," Advanced Telemetry Study Technical Report, 1 Part 1, 15 Feb 1961.
6. "Study and Experimental Investigation on Sampling Rate and Aliasing in Time-Division Telemetry Systems," Aeronutronic Publication U-1387, 28 Sep 1961.
7. Bigelow, G. F., "Status of Microwave Telemetry Implementation," IRE PGSET Record, Section 2.3, Oct 1962.

<p>AD ACCESSION NR Instrumentation Department, U. S. Army Electronics Research and Development Activity, White Sands Missile Range, New Mexico</p> <p>INTERPRETING THE IRIG STANDARDS FOR PAM/FM TELEMETRY, By Robert C. Barto, Technical Report USA ERDA-23, 11 pp incl illus, May 1963</p> <p><u>UNCLASSIFIED Report</u></p> <p>Knowledge of the technical basis underlying the particular choice of parameters, quantities, and configurations specified in the Telemetry Standards could lead to the more effective use of the document. During the preparation phase, such technical information is assembled to form the basis of the Standard. Although there was no attempt to preserve or organize such information during the recent preparation of the Standard for PAM/FM Telemetry, some of this material is available and is drawn upon to discuss interesting sections of the Standard.</p>	<p>UNCLASSIFIED</p> <p>1. Telemetry Standards 2. PAM/FM Telemetry 3. IRIG Document 106-60</p> <p>Copies of this document may be obtained upon request from: Defense Documentation Center Arlington Hall Station Arlington 12, Virginia</p>	<p>AD ACCESSION NR Instrumentation Department, U. S. Army Electronics Research and Development Activity, White Sands Missile Range, New Mexico</p> <p>INTERPRETING THE IRIG STANDARDS FOR PAM/FM TELEMETRY, By Robert C. Barto, Technical Report USA ERDA-23, 11 pp incl illus, May 1963</p> <p><u>UNCLASSIFIED Report</u></p> <p>Knowledge of the technical basis underlying the particular choice of parameters, quantities, and configurations specified in the Telemetry Standards could lead to the more effective use of the document. During the preparation phase, such technical information is assembled to form the basis of the Standard. Although there was no attempt to preserve or organize such information during the recent preparation of the Standard for PAM/FM Telemetry, some of this material is available and is drawn upon to discuss interesting sections of the Standard.</p>	<p>UNCLASSIFIED</p> <p>1. Telemetry Standards 2. PAM/FM Telemetry 3. IRIG Document 106-60</p> <p>Copies of this document may be obtained upon request from: Defense Documentation Center Arlington Hall Station Arlington 12, Virginia</p>
<p>AD ACCESSION NR Instrumentation Department, U. S. Army Electronics Research and Development Activity, White Sands Missile Range, New Mexico</p> <p>INTERPRETING THE IRIG STANDARDS FOR PAM/FM TELEMETRY, By Robert C. Barto, Technical Report USA ERDA-23, 11 pp incl illus, May 1963</p> <p><u>UNCLASSIFIED Report</u></p> <p>Knowledge of the technical basis underlying the particular choice of parameters, quantities, and configurations specified in the Telemetry Standards could lead to the more effective use of the document. During the preparation phase, such technical information is assembled to form the basis of the Standard. Although there was no attempt to preserve or organize such information during the recent preparation of the Standard for PAM/FM Telemetry, some of this material is available and is drawn upon to discuss interesting sections of the Standard.</p>	<p>UNCLASSIFIED</p> <p>1. Telemetry Standards 2. PAM/FM Telemetry 3. IRIG Document 106-60</p> <p>Copies of this document may be obtained upon request from: Defense Documentation Center Arlington Hall Station Arlington 12, Virginia</p>	<p>AD ACCESSION NR Instrumentation Department, U. S. Army Electronics Research and Development Activity, White Sands Missile Range, New Mexico</p> <p>INTERPRETING THE IRIG STANDARDS FOR PAM/FM TELEMETRY, By Robert C. Barto, Technical Report USA ERDA-23, 11 pp incl illus, May 1963</p> <p><u>UNCLASSIFIED Report</u></p> <p>Knowledge of the technical basis underlying the particular choice of parameters, quantities, and configurations specified in the Telemetry Standards could lead to the more effective use of the document. During the preparation phase, such technical information is assembled to form the basis of the Standard. Although there was no attempt to preserve or organize such information during the recent preparation of the Standard for PAM/FM Telemetry, some of this material is available and is drawn upon to discuss interesting sections of the Standard.</p>	<p>UNCLASSIFIED</p> <p>1. Telemetry Standards 2. PAM/FM Telemetry 3. IRIG Document 106-60</p> <p>Copies of this document may be obtained upon request from: Defense Documentation Center Arlington Hall Station Arlington 12, Virginia</p>