

UNCLASSIFIED

AD 410356

DEFENSE DOCUMENTATION CENTER

FOR

SCIENTIFIC AND TECHNICAL INFORMATION

CAMERON STATION, ALEXANDRIA, VIRGINIA



UNCLASSIFIED

NOTICE: When government or other drawings, specifications or other data are used for any purpose other than in connection with a definitely related government procurement operation, the U. S. Government thereby incurs no responsibility, nor any obligation whatsoever; and the fact that the Government may have formulated, furnished, or in any way supplied the said drawings, specifications, or other data is not to be regarded by implication or otherwise as in any manner licensing the holder or any other person or corporation, or conveying any rights or permission to manufacture, use or sell any patented invention that may in any way be related thereto.

N-63-4-3

TECHNICAL INFORMATION SERIES

CATALOGED BY DDC

410356

AS AD NO.

R63SD35

PERFORMANCE OF SEVERAL ABLATION
MATERIALS IN SIMULATED PLANETARY
ATMOSPHERES

JUL 24 1963
LIBRARY OF THE
TISIA A

R.A. SHERIDAN
N.S. DIACONIS
W.R. WARREN

410356

SPACE SCIENCES LABORATORY

GENERAL  ELECTRIC

MISSILE AND SPACE DIVISION

SPACE SCIENCES LABORATORY

PERFORMANCE OF SEVERAL ABLATION MATERIALS
IN SIMULATED PLANETARY ATMOSPHERES

by

R. A. Sheridan
N. S. Diaconis
W. R. Warren, Jr.

This work was supported by the Jet Propulsion
Laboratory, Contract No. 950250, and by the
General Electric Co. under Contractor's
Independent Research and Development Program.

R63SD35 - Class I
April, 1963

MISSILE AND SPACE DIVISION

GENERAL  ELECTRIC

CONTENTS

PAGE

ABSTRACT	1
INTRODUCTION	2
ARC TEST FACILITY	2
TEST PROGRAM	4
TEST RESULTS AND DISCUSSION	6
CONCLUSIONS	12
TABLE 1	13
TABLE 2	14
NOMENCLATURE	15
REFERENCES	16
FIGURES	

PERFORMANCE OF SEVERAL ABLATION MATERIALS
IN SIMULATED PLANETARY ATMOSPHERES

R. A. Sheridan
N. S. Diaconis
W. R. Warren, Jr.

ABSTRACT

The thermal protection by ablation of vehicles entering simulated planetary atmospheres was the subject of the present study. The capability for such a study was provided by the Space Sciences Laboratory's tandem Gerdien arc -- a high purity, high enthalpy design, adapted to free jet testing. Well known ablation materials typical of three classes of ablaters were tested in the arc-heated gas mixture representative of Martian and Venusian atmospheres. The performance of each material in each gas mixture is evaluated and compared with similar performance in air. The results illustrate the severity of the entry problem for Mars and Venus relative to Earth re-entry for high heating rate or primarily steady state ablation situations. The effects of non-steady ablation and gas radiation on material performance were not studied.

INTRODUCTION

The thermal protection by ablation of vehicles entering simulated planetary atmospheres was the subject of the present study. The capability for such a study was provided by the Space Sciences Laboratory's tandem Gerdien arc -- a high purity, high enthalpy design, adapted to free jet testing. Well known ablation materials typical of three classes of ablators were tested in the arc-heated gas mixtures representative of Martian and Venusian atmospheres. The performance of each material in each gas mixture is evaluated and compared with similar performance in air. The results illustrate the severity of the entry problem for Mars and Venus relative to Earth re-entry for high heating rate or primarily steady state ablation situations. The effects of non-steady ablation and gas radiation on material performance were not studied.

ARC TEST FACILITY

The tandem Geriden arc design was adapted to free jet testing of ablation materials. The arc heater provides contaminant-free high enthalpy flow due to its constrictor plate design and the flow velocity distribution in the arc (Fig. 1). Argon sheathed electrodes were incorporated in order to substantially reduce the electrode consumption rate. Since the inlet gas is divided into four portions, two flowing through the arc, plenum chamber and nozzle (test gas) and two flowing past the electrodes to a dump valve, no

electrode material or argon is entrained in the test gas.

The tandem Gardien arc was developed by McGinn at the Space Sciences Laboratory (Ref. 1). It incorporated the principles and experience gained in the seven years of arc technology at the Laboratory. The arc unit included the latest feature of arc development -- argon swirl electrodes. The graphite electrodes are shrouded in argon contained by a water-cooled copper housing. The argon prevents combustion of the electrodes, and the argon and carbon are dumped to prevent contamination of the test gas.

Other modifications of the arc unit were needed to adapt it to free jet testing. The model actuation mechanism is shown in Figure 2. A slot was made in the plenum wall for full viewing of the models; the back pots were modified to accommodate the argon swirls, and other changes were made to facilitate the operation of the arc. Power, water, gas and hydraulic lines were installed along with sufficient instrumentation to monitor the operational parameters of the arc.

An advantage gained when the arc became operational was the utilization of the new power source. The rectified power supply provides a more constant source than the old supply and at higher power levels. Improved operation of the arc was clearly noted.

After the initial trial runs with the newly built free jet arc (Fig. 3) the purity of the flow was checked spectrographically. The amount of inlet flow past the argon sheathed electrodes and the amount exhausted were varied until the test gas species showed a high degree of purity (contamination approximately 0.1% by mass).

Some difficulties were encountered in the initial operation of the arc unit. Water leaks and occasional electrical failures necessitated several delays while repairs were made. The arc was debugged and brought under control and the performance was measured to a satisfactory degree. The arc current and voltage, the plenum pressure, the purity of the flow, the stagnation temperature and stagnation enthalpy were determined for the arc.

The stagnation enthalpy of the gas mixtures was determined with a water cooled total calorimeter (Fig. 4). The calorimeter collects the gas, cools it and then exhausts it through a flow meter. The arc conditions are maintained constant until the calorimeter comes to equilibrium. The enthalpy is determined from the water temperature rise and the weight flow of gas.

Model heat transfer rates are determined through transient backwall temperature measurements in a cylindrical slug located at the stagnation point of a plastic model.

TEST PROGRAM

The objective of the program was to determine experimentally the behavior of typical thermal protection materials that might be used for Mars and Venus entry vehicles. An approach that would allow compensation for any mis-estimate of the percentages of the nitrogen-carbon dioxide mixture for the planets was used. The percentage of CO_2 (in a $\text{CO}_2\text{-N}_2$ mixture) was varied from 0 to 25%. The three mixtures tested then allow results to be approximated for any mixture by interpolation. Test results in the simulated atmospheres were also compared with air data.

Nominally, the gas mixtures selected for the program were air, nitrogen, and the "best" estimate and the extreme estimate for the Venus atmosphere. The actual N₂-CO₂ mixtures desired and those obtained from the vendor were as follows:

<u>Mixtures Specified</u>	<u>Mixtures Supplied</u>
90% N ₂ , 9% CO ₂ , 1% A	88.6% N ₂ , 10% CO ₂ , 1.4% A
74% N ₂ , 25% CO ₂ , 1% A	74.1% N ₂ , 24.7% CO ₂ , 1.2% A

These were considered to be satisfactory mixtures for the purposes of the program.

The materials selected for study are representative of three somewhat general classes of ablators:

Phenolic Nylon -- pyrolyzes and chars

ATJ Graphite -- combusts at the surface

Teflon -- sublimes

To permit comparison of the model test in the different gas mixtures it is necessary to fix certain test parameters. The stagnation pressure was kept essentially constant and the stagnation enthalpy relatively constant for each series of test gases. In this way the results are comparable among themselves and are representative of stagnation region ablation material performance at a specific flight velocity and flight altitude.

The majority of the tests were performed in the stagnation enthalpy range of 12,000 to 14,000 BTU/lb. A few tests were made in a 10,000 BTU/lb enthalpy range. The maximum simulated flight velocity and altitude values were approximately 26,500 ft/sec and 83 KM (for a simulated Venusian atmosphere).

TEST RESULTS AND DISCUSSION

The stagnation enthalpy values determined with the total calorimeter are shown in Table 1. The tests were repeated at least twice for each gas mixture and the results indicated that the arc flow conditions are highly repeatable (+ 2%). Table 1 shows the operating pressure in the plenum, the enthalpy increase of the test gas due to arc heating, the stagnation enthalpy and the wall enthalpies at wall temperatures of 1500°R and 5400°R for each gas mixture. Also shown are the heat transfer rates for each gas at the two wall temperature conditions of interest. The calculated equilibrium thermochemical properties given in Reference 2 were used to determine the necessary properties used below in the data presentation (h_{∞} , h_w).

Model stagnation point heat transfer rate data (non-ablating) was obtained for each gas. The results indicated that many additional runs would have to be made to obtain reliable mean heat transfer rates for each gas. The reasons for this are that at the high test heat transfer rates (of the order of 2500 BTU/ft²-sec), first, the plastic calorimeter holder ablates quickly near the copper insert, and, second, the surface temperature of the copper quickly approaches its melting level. Thus, during the time for which the calorimeter responds accurately it is difficult to measure the temperature slope data (with present equipment). The result is an appreciable scatter in the reduced heat transfer rates (+ 10 to 15%).

There was insufficient time to conduct the number of tests required for each gas in this program; therefore, a semi-empirical method was used. The mean heat transfer rate in air was determined from several experiments

at the high h_s levels (Table 1). Theoretical relationships for air, nitrogen, and CO_2 (Ref. 3 and 4) were then used to establish heat transfer ratios between each test gas and air at the appropriate stagnation enthalpy level.

Thus, the heating rate for each gas was calculated according to

$$q_{o_t} = \dot{q}_{air\ meas} \frac{(h_s - h_w)_t}{(h_s - h_w)_{air}} \cdot \frac{(\dot{q} \sqrt{R_o/P}_{s_t})}{(\dot{q} \sqrt{R_o/P}_{s_{air}})}$$

where

$$R_{o_t} = R_{o_{air}} \quad \text{and} \quad P_{s_t} \approx P_{s_{air}}$$

Since the enthalpies and theoretical heating rates for each gas differ from the air values only by the order of 20% and 10%, respectively, this procedure should be satisfactory. A further justification is found in the good facility operation repeatability. As a check on the measured heating rate levels, calculations for air at the test conditions were made for stagnation point velocity gradients corresponding to incompressible potential flow and for the modified Newtonian prediction. The potential value agrees (within 3%) with the mean measured value as would be expected for the subsonic free jet test condition used.

The different ablators were tested for durations up to 6 seconds. Longer test times would be meaningless because of the large amount of material loss and shape change of the models. However, at the heating rates of interest, steady state ablation conditions are established for most materials in a small fraction of this time. Figure 5 shows typical models tested for four seconds duration. The shape changes are to be noted, especially for

the teflon. The phenolic nylon has a strong thick char layer so that the shape change is not as pronounced as with teflon. However, the shape change of the virgin phenolic nylon is quite large because of the side heating and char growth. ATJ graphite data is not shown, although the material was tested in each gas. The mass loss in air at a measured surface temperature of 5400°R was significantly higher than expected. The theory for graphite and its experimental verification are presented in References 5 and 6. The increased mass loss occurs after the test flow is terminated, that is, the surface continues to combust in the room air as the model cools. Due to the heat capacity of graphite the duration of temperature decay is several times the test duration. This problem was not found for the other materials tested since with them little total heat is absorbed during test, and what is stays near the surface resulting in a short cool-down period. Thus, the graphite data are not included since the results could be misleading. Even with the apparent (and erroneous) increase in mass loss, the material ablation rate was still much less than for PN at the same test conditions. It must be remembered, however, that graphite blocks much less heat than does, for example, PN, resulting in its high internal temperatures. Therefore, mass loss becomes a relatively less important design consideration for graphite.

It is noted that this problem for graphite can be eliminated in future studies by providing an inert gas bath for the test models during the cooling period.

The models before test (Fig. 5) are hemisphere-cylinders 1/2 inch in diameter. A 3/16 inch diameter by 1 inch long slug of the same material is

inserted at the stagnation point of the model. All test measurements are made for this slug. This technique allows the obtaining of stagnation region data as opposed to data integrated over the complete model surface. The right fit eliminates effects due to the model-slug joint.

Weight and length measurements are taken from the slug before and after test. Typical test specimens are shown in Figure 6. Note the char cap positioned above the phenolic nylon specimen. This becomes detached from the slug when it is removed from the model after test. The weight loss and char thickness for the series of runs for phenolic nylon and teflon are given in Table 2. The ratios of the initial model radius ($R_0 = 1/4''$) to the average radius after test (R_t) are also shown.

Spectrograms were taken of each model in each test gas to attempt to justify the use of a two-color pyrometer to determine the surface temperature history of the test specimens. The spectrograms showed that neither color nor brightness temperatures could be determined with the pyrometer for the majority of the tests. That is, the gas radiation continuum was too intense and extensive to provide "windows" of sufficient frequency interval to see the model surface satisfactorily with the pyrometer. To obtain some information on the surface temperatures, a few additional spectrographic measurements were made. The temperatures determined from analysis of the spectrograms were as follows:

High Enthalpy Test Conditions

<u>Test Gas</u>	<u>Material</u>	<u>Surface Temperature</u>
10% CO ₂ , 88.6% N ₂ , 1.4% A	ATJ graphite	3900°K ± 100°K
Air	ATJ graphite	2900°K ± 100°K
Air	Phenolic nylon	3000°K ± 100°K

The surface temperatures assumed for all the tests were 3000°K for phenolic nylon and 1500°R for teflon (based on previous experimental and theoretical experience with teflon - Refs. 7 and 8). It is interesting to note that the surface temperatures of graphite are significantly higher in the 10% CO₂ mixture than in air. This is expected since the ablation mechanism for graphite is primarily combustion. (Note that sublimation should start at about 3700°K for graphite at one atmosphere.) It is not anticipated that PN or teflon will exhibit this type of change since their ablation mechanisms are not dominated by combustion. However, this point should be checked in future studies.

Figure 7 shows the weight loss vs. time for teflon and phenolic nylon in each test gas mixture at the two nominal enthalpy levels. The data do not show a linear correlation since the model heating rate is decreasing with time (nose radius changing). The data was reduced on the basis of instantaneous values. The mass loss is computed from the slope of the weight loss-time curve and a heat transfer rate, appropriate to the model nose radius at the same time of test, is calculated according to

$$\frac{\dot{q}_t}{\dot{q}_{o_t}} = \left(\frac{R_o}{R_t} \right)^{1/2}$$

The heat of ablation is defined as

$$Q^* = \frac{\dot{q}_t}{\dot{m}}$$

where \dot{q}_t and \dot{m} are determined as above with \dot{q}_t corrected for back radiation from the model surface.

The heats of ablation for teflon and phenolic nylon in each test gas are shown in Figures 8 and 9 as a function of $(h_s - h_w)$. The range of data is shown by a bar in some cases where variation in values were obtained for the different times of test at which the data were evaluated.

The heats of ablation for teflon in air show reasonable agreement with the theory of Scala (Ref. 7). Good agreement was obtained at low enthalpy levels by Diaconis, et al (Ref. 8).

The heat of ablation values for phenolic nylon exhibit a reasonable trend with respect to the approximate theoretical curve shown. It is pointed out that the heat of ablation for a charring material depends upon the distribution of the various parts of the total heat input. Thus, the heat of ablation can vary depending upon the char thickness and its variation with time, the virgin material boundary wall temperature, the rate of oxidation, the molecular weight of the transpired gases and other factors that are difficult to include accurately in a theoretical description. The theory shown is for an "idealized" charring ablator and is not meant to represent an accurate theory for the test case.

CONCLUSIONS

The stagnation point steady state ablation performance of two general types of ablators were evaluated in a high purity-high enthalpy free jet arc facility in air and nitrogen-carbon dioxide gas mixtures. The mixtures are assumed to represent possible Mars and Venus atmospheres. The ratio of radiative to convective heat transfer was small and therefore the results do not reflect material performance in a highly radiating environment.

The heat of ablation results for teflon suggest that ablation is more severe in air and in the N_2 - CO_2 mixtures than in N_2 alone; however, the maximum spread between data points is only about 20%. For phenolic nylon, no consistent effect of gas composition is apparent in the data. It is concluded that the steady state ablation performance does not differ grossly between air and the simulated planetary atmospheres at least for the materials and test conditions investigated.

The test results for graphite were found to be in error because of the large mass losses experienced during cooldown after the test flow was terminated. However, the mass losses were still less than those found for phenolic nylon. Also, the surface temperatures for graphite measured during the test flow were significantly higher than those for phenolic nylon.

TABLE 1
ARC TEST CONDITIONS

	<u>Air</u>	<u>N₂</u>	<u>10% CO₂</u>	<u>25% CO₂</u>
<u>High Enthalpy Test Conditions</u>				
P _s (psig)	3.0	2.8	2.9	3.1
h/RT _o	364	415	400	384
h _o /RT _o	3.9	3.9	-11.5	-35.5
h _s /RT _o	368	419	388	348
h _w /RT _o (T _w = 1500°R)	11.4	11.4	-4.2	-28.3
$\frac{h_s - h_w}{RT_o}$ (T _w = 1500°R)	357	408	393	377
\dot{q}_{ot} (T _w = 1500°R)	2480	2900	2900	2920
h _w /RT _o (T _w = 5400°R)	52	45.6	40.3	26.8
$\frac{h_s - h_w}{RT_o}$ (T _w = 5400°R)	316	373	348	322
\dot{q}_{ot} (T _w = 5400°R)	2260	2610	2540	2480
<u>Low Enthalpy Test Conditions</u>				
P _s (psig)		2.3	2.4	2.5
h/RT _o		286	306	306
h _s /RT _o		290	295	270
$\frac{h_s - h_w}{RT_o}$ (T _w = 1500°R)		279	299	299
\dot{q}_{ot} (T _w = 1500°R)		1940	2120	2240
$\frac{h_s - h_w}{RT_o}$ (T _w = 5400°R)		244	254	244
\dot{q}_{ot} (T _w = 5400°R)		1740	1840	1840
R _o = 1/4"				
RT _o = 33.86 BTU/LB				
\dot{q}_{rad} (T _w = 5400°R) = 440 BTU/LB (Back Radiation from surface)				

TABLE 2
TEST RESULTS

Material	Gas	h_s/RT_o	Time (sec)	ΔW (gms)	t_{char} (in.)	$\frac{R_o}{R_t}$	
Phenolic Nylon	Air	368	2.4	.0404	.029	--	
			3	.0505	.032	.67	
			4	.0522	.027	.56	
			5	.0615	.034	.47	
			6.1	.0745	.040	.25	
			2	.0351	.050		
	N ₂	419	3	.0382	--		
			6	.0730	--		
			2	.0303	.052	.80	
	10% CO ₂	388	4	.0463	.055	.64	
			5	.0628	.047	.56	
			6	.0652	.066	.47	
	25% CO ₂	348	2.5	.0434	.071	.76	
			4	.0613	.053	.58	
			6	.0765	.026	.42	
Teflon	Air	368	2.3	.1358		.94	
			3.9	.2005		.89	
			6.2	.2726		.73	
			2	.0865		.97	
			3	.1218		.94	
			6	.2361		.86	
	10% CO ₂	388	2	.0836		.97	
			4	.2063		.91	
			6	.3166		.84	
	25% CO ₂	348	2.2	.0884		.91	
			4.2	.1872		.80	
			5.8	.2955		.71	
	Phenolic Nylon	N ₂	290	2.2	.0276	.072	.86
				4	.0458	.050	.67
		10% CO ₂	295	2	.0293	.055	.80
4				.0464	.073	.76	
25% CO ₂		270	2	.0284	.044	.84	
			4.1	.0494	.052	.80	
Teflon	N ₂	290	2	.1858		.97	
			4	.187		.97	
	10% CO ₂	295	2.1	.0834		.97	
			4.3	.1728		.97	
	25% CO ₂	270	2	.0873		1.00	
			4.1	.1887		1.00	

NOMENCLATURE

h	enthalpy
\dot{m}	mass loss rate
P	pressure
Q^*	heat of ablation
\dot{q}	heat transfer rate
R	nose radius
RT_o	33.86 BTU/lb
t	time
t_{char}	thickness of char cap
T	temperature
ΔW	weight loss

Subscripts

o	initial
s	stagnation
t	test
w	wall
rad	radiation

REFERENCES

1. McGinn, J. H., and Weber, H. E.; A Constricted Arc for High Energy Gas Flow; Aerospace Engineering J., January, 1963.
2. Browne, W. G.; Thermodynamic Properties of the Venusian Atmosphere; Advanced Aerospace Physics TM 13 (Three parts); June 11, 1962.
3. Scala, S. M., and Baulknight, C. W.; Transport and Thermodynamic Properties in a Hypersonic Laminar Boundary Layer -- Part 2, Applications; ARS Journal 30, No. 4, April, 1960.
4. Scala, S. M.; Private Communication.
5. Scala, S. M.; The Ablation of Graphite in Dissociated Air: Part I, Theory; IAS Nat'l Summer Meeting, Los Angeles, Calif., June 19-22, 1962. GE MSD TIS R62SD72, September, 1962.
6. Diaconis, N. S., Gorsuch, P. D., and Sheridan, R. A.; The Ablation of Graphite in Dissociated Air, Part II, Experiment; IAS National Summer Meeting, Los Angeles, Calif., June 19-22, 1962. GE, MSD TIS R62SD86, September, 1962.
7. Scala, S. M.; A Study of Hypersonic Ablation; 10th International Astronautical Congress, London, 20 August to 5 September 1959.
8. Diaconis, N. S., Fanucci, J. B., and Sutton, G. W.; The Heat Protection Potential of Several Ablation Materials for Satellite and Ballistic Re-entry into the Earth's Atmosphere; Ballistic Missile and Space Technology, Vol. II, Pergamon Press, 1961.
9. Metzger, J. W.; Ablation Data on Molded Phenolic Nylon Tested in the Shroud Nozzle Air Stabilized Arc; Advanced Aerodynamics TM No. 92; September, 1959.

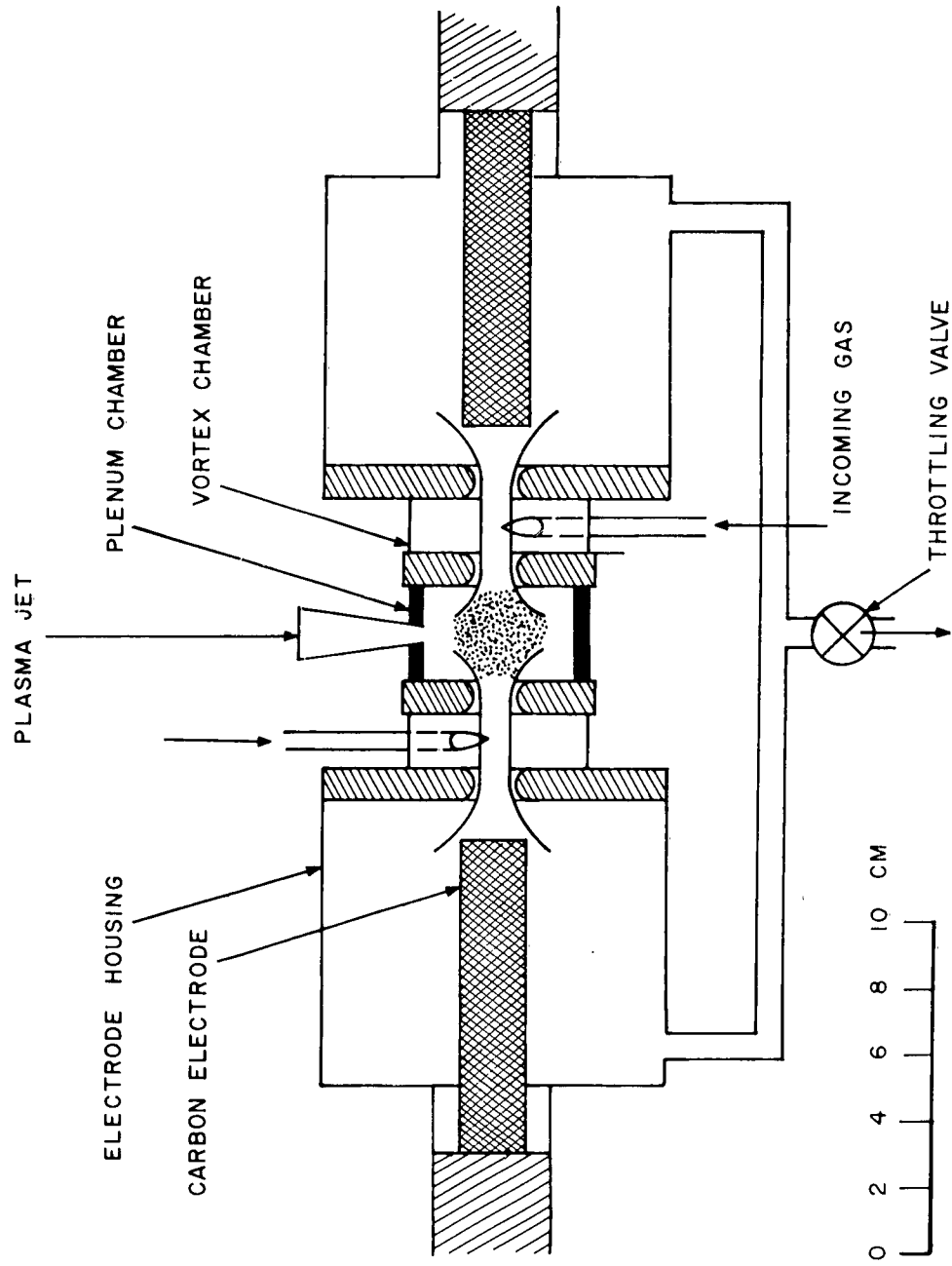
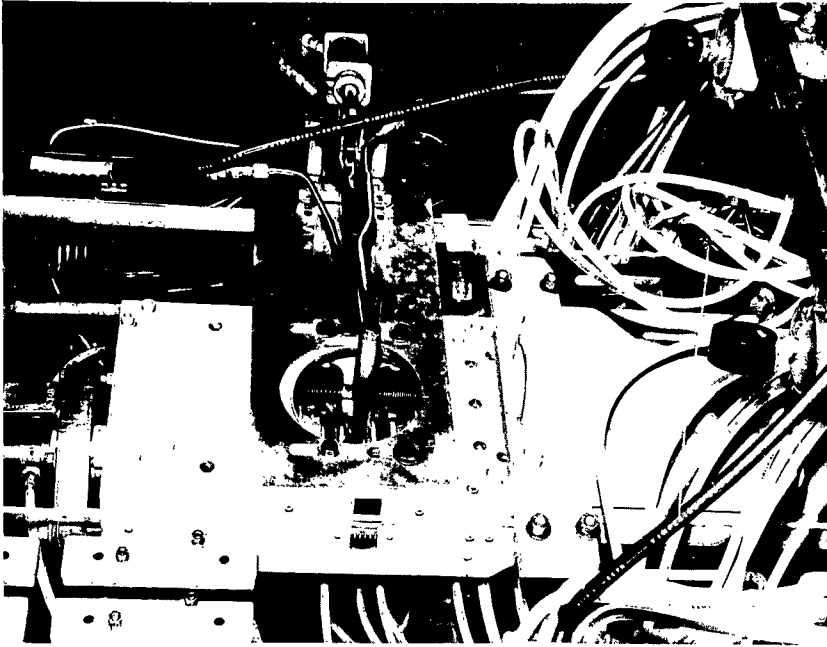
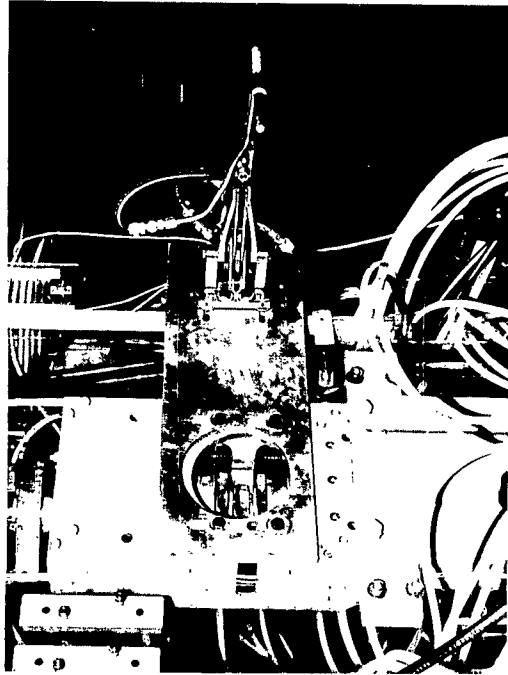

Figure 1. Tandem Gerdien Arc Design



b. Model In



a. Model Out

Figure 2. Model Testing - Tandem Gerdien Free Jet Arc

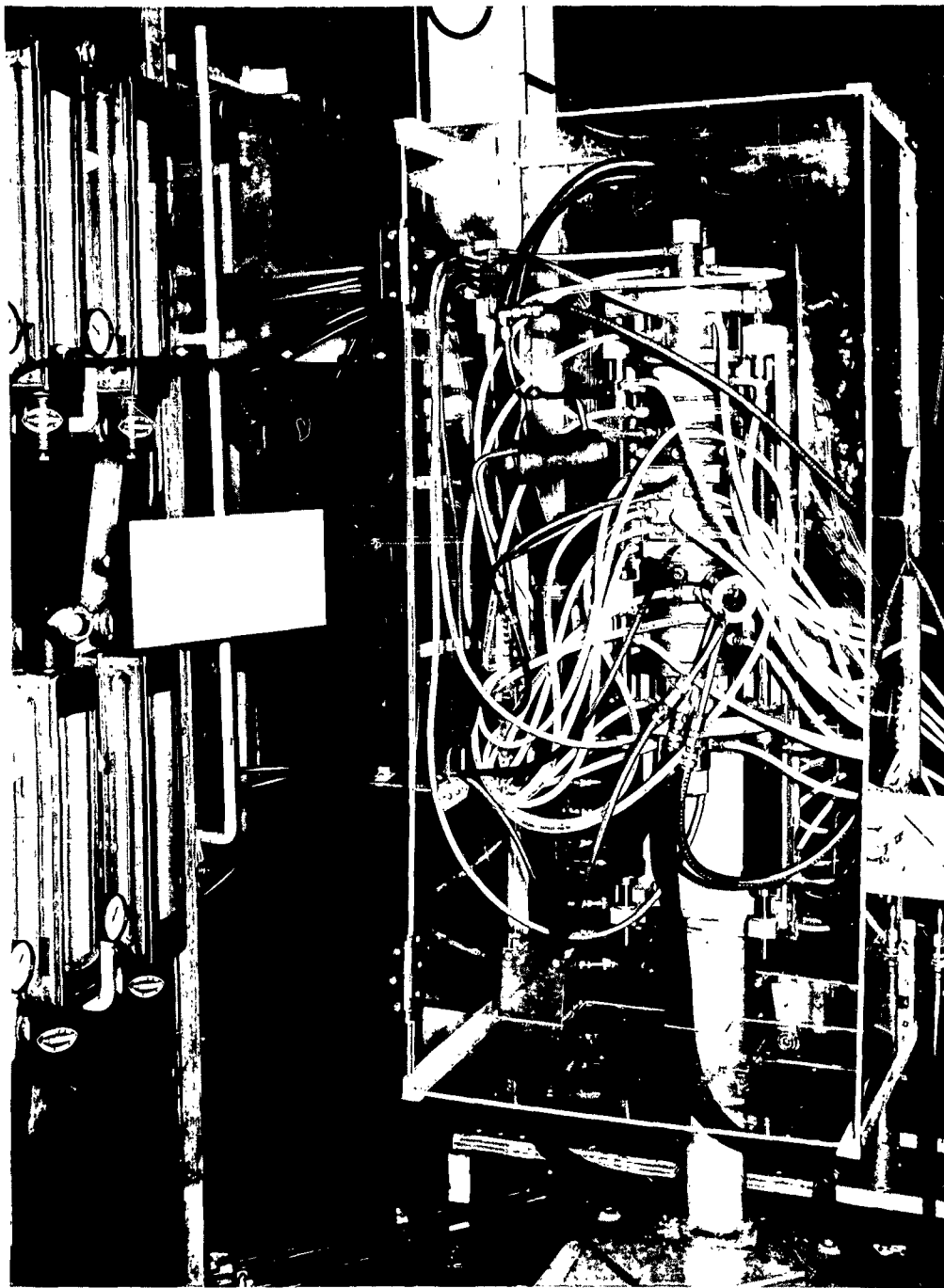

Figure 3. Arc Heater - Tandem - Gerdien Free Jet

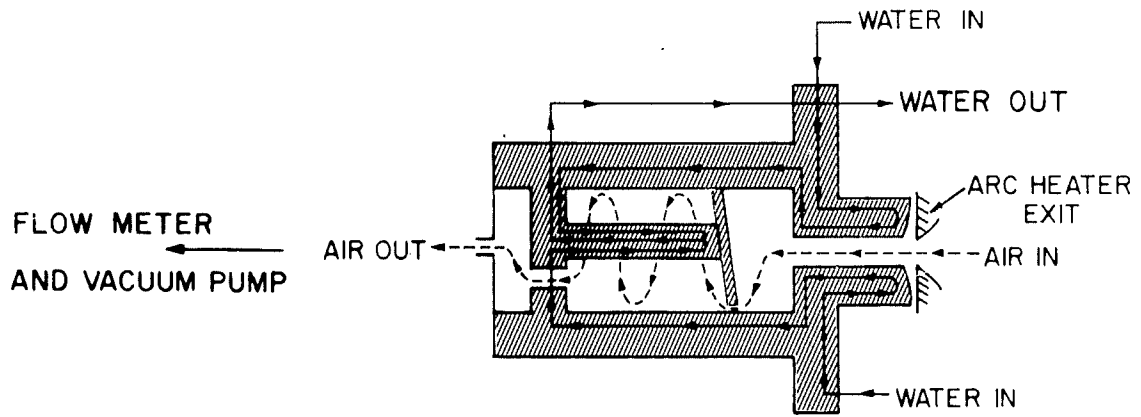
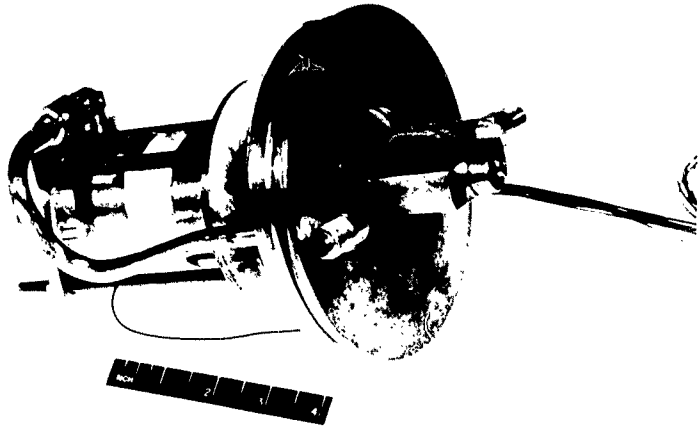

Figure 4. Total Enthalpy Calorimeter

BEFORE



AFTER

$h_s \sim 9,600$ BTU/lb

$t = 4$ seconds



GRAPHITE

PHENOLIC NYLON

TEFLON



Figure 5. Typical Models

$h_s \sim 13,000 \text{ BTU/lb}$

$t = 4 \text{ seconds}$



Figure 6. Typical Model Specimens

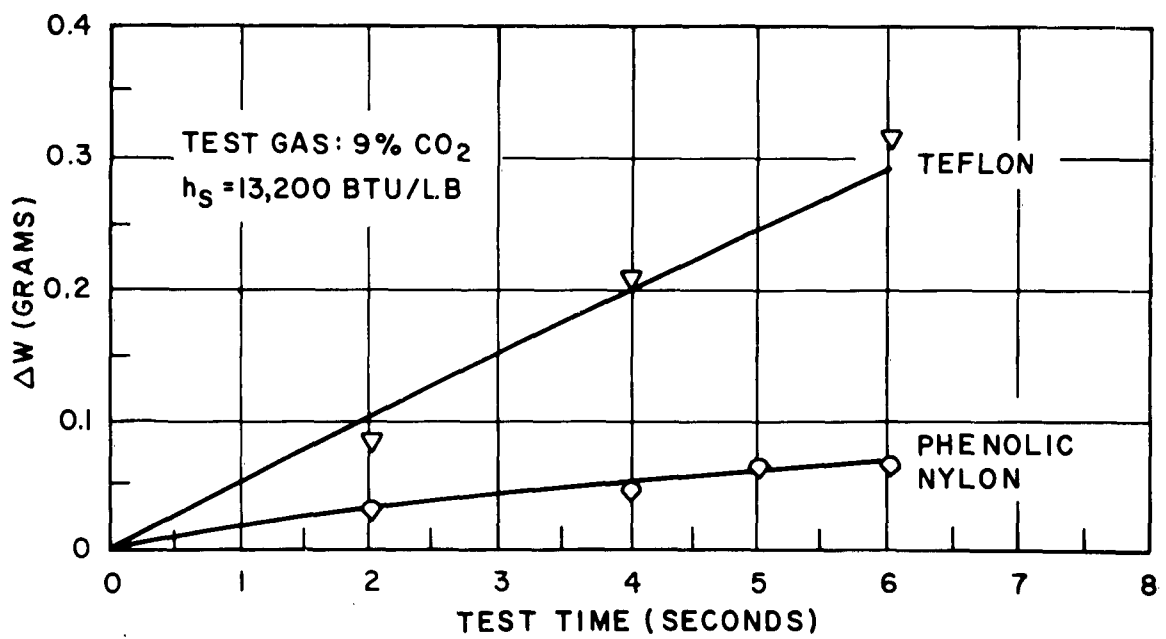
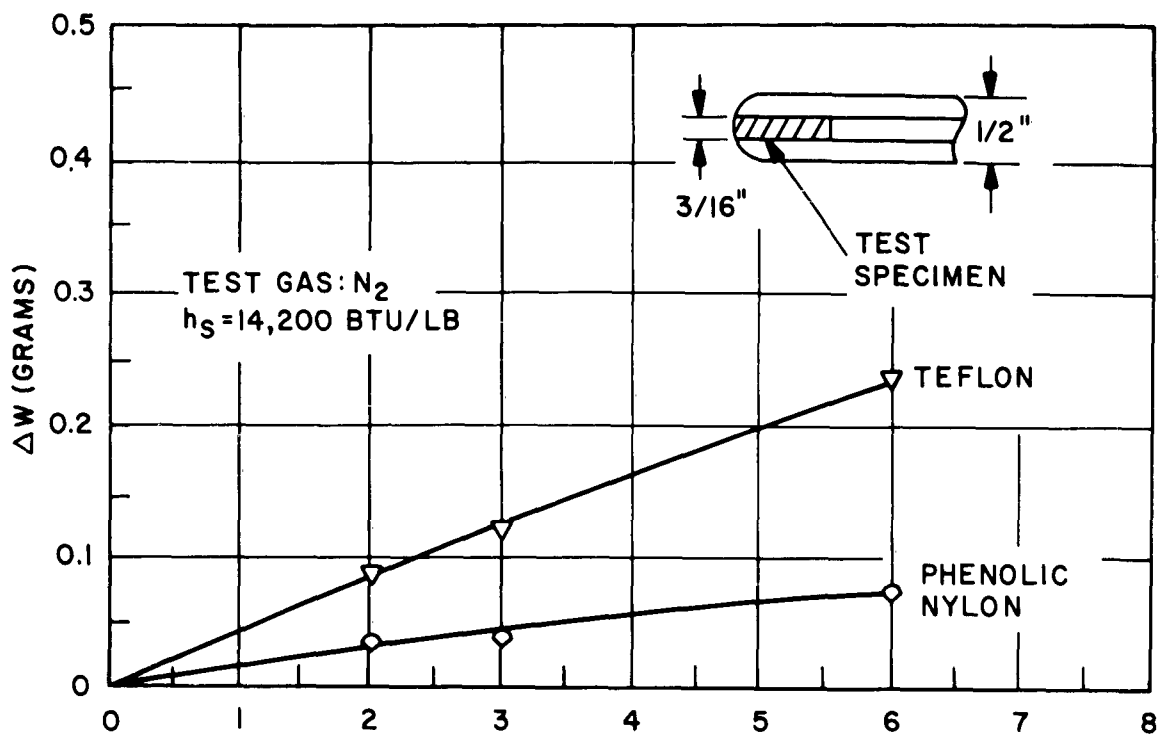

Figure 7a. Mass Loss of Ablators

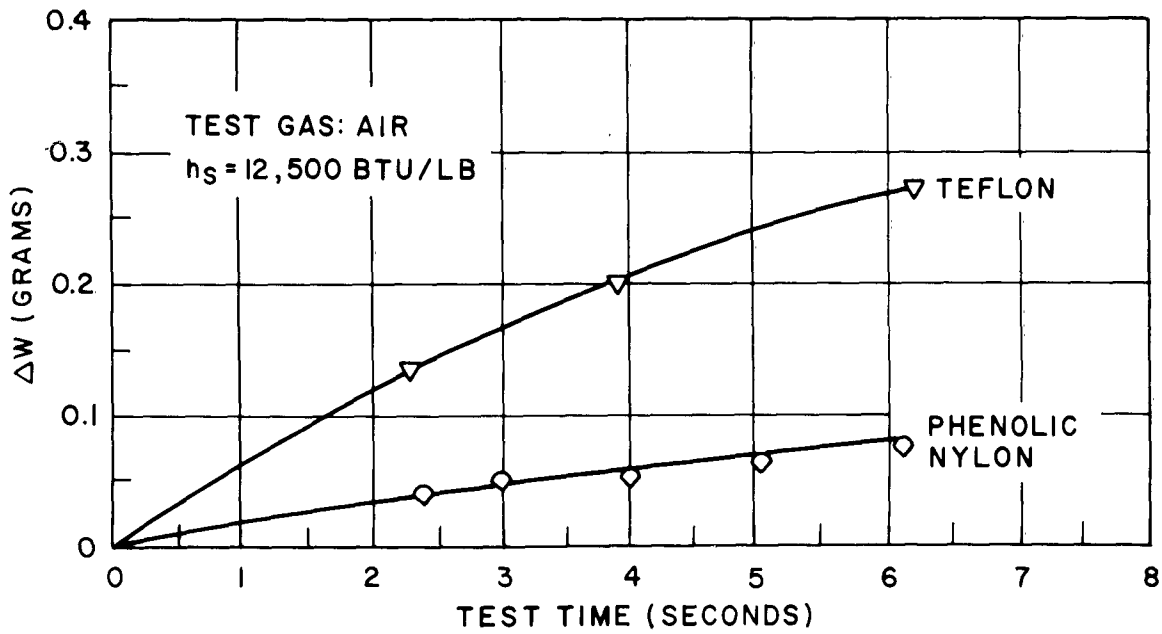
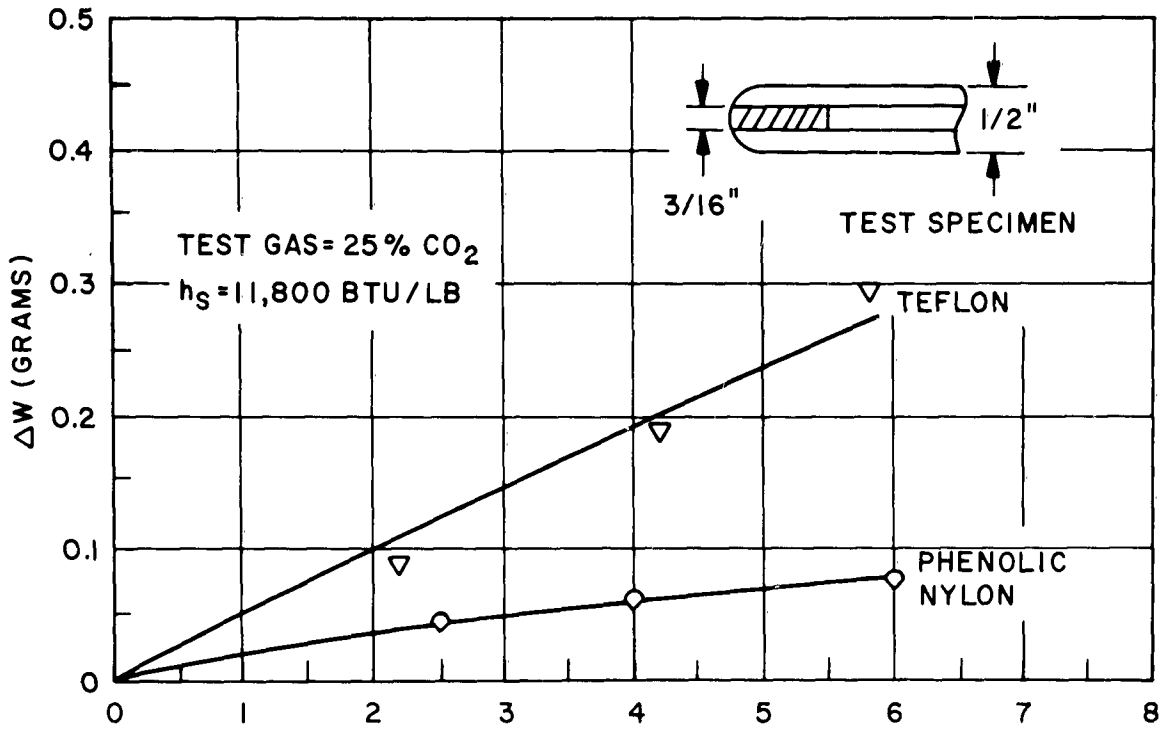

Figure 7b. Mass Loss of Ablators

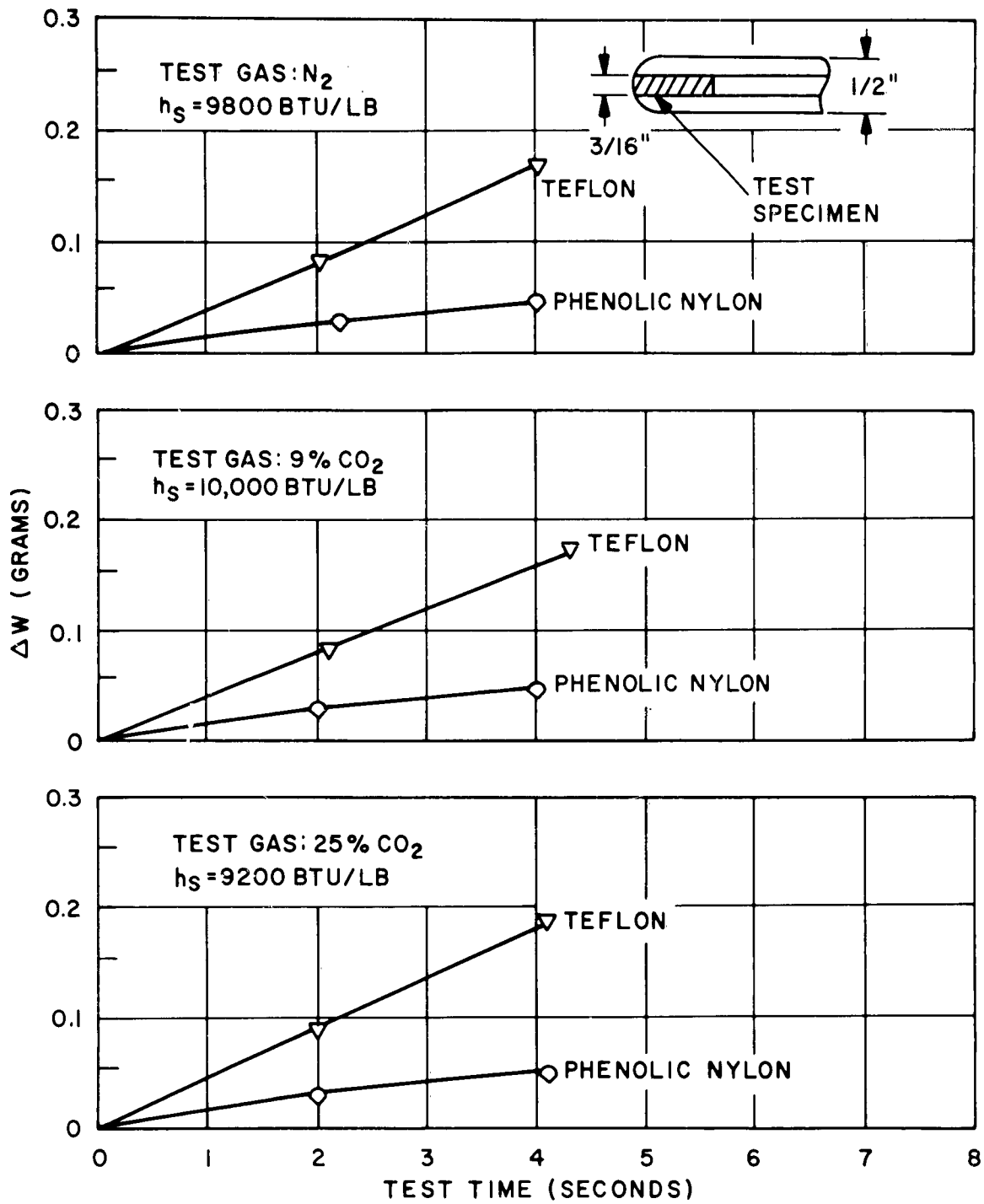

Figure 7c. Mass Loss of Ablators

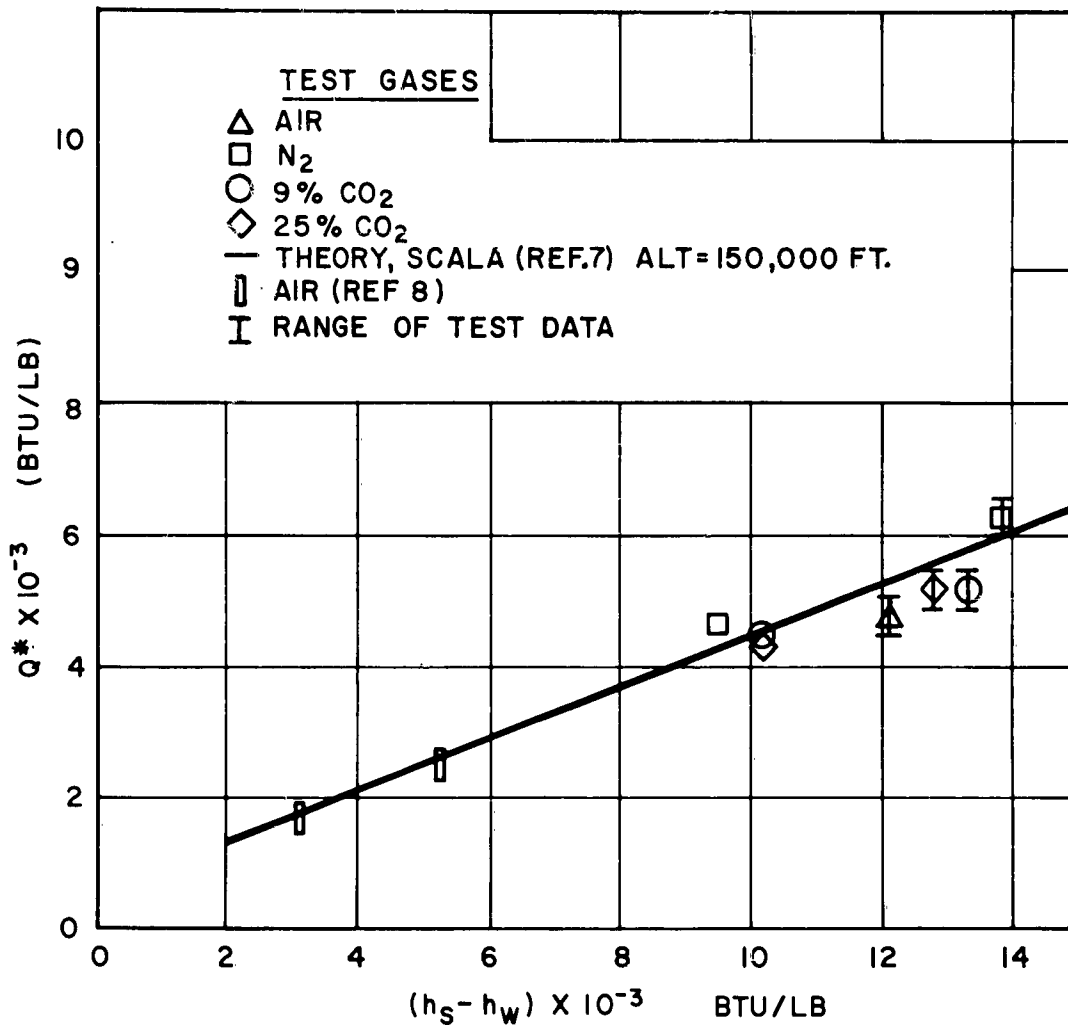

Figure 8. Heats of Ablation for Teflon

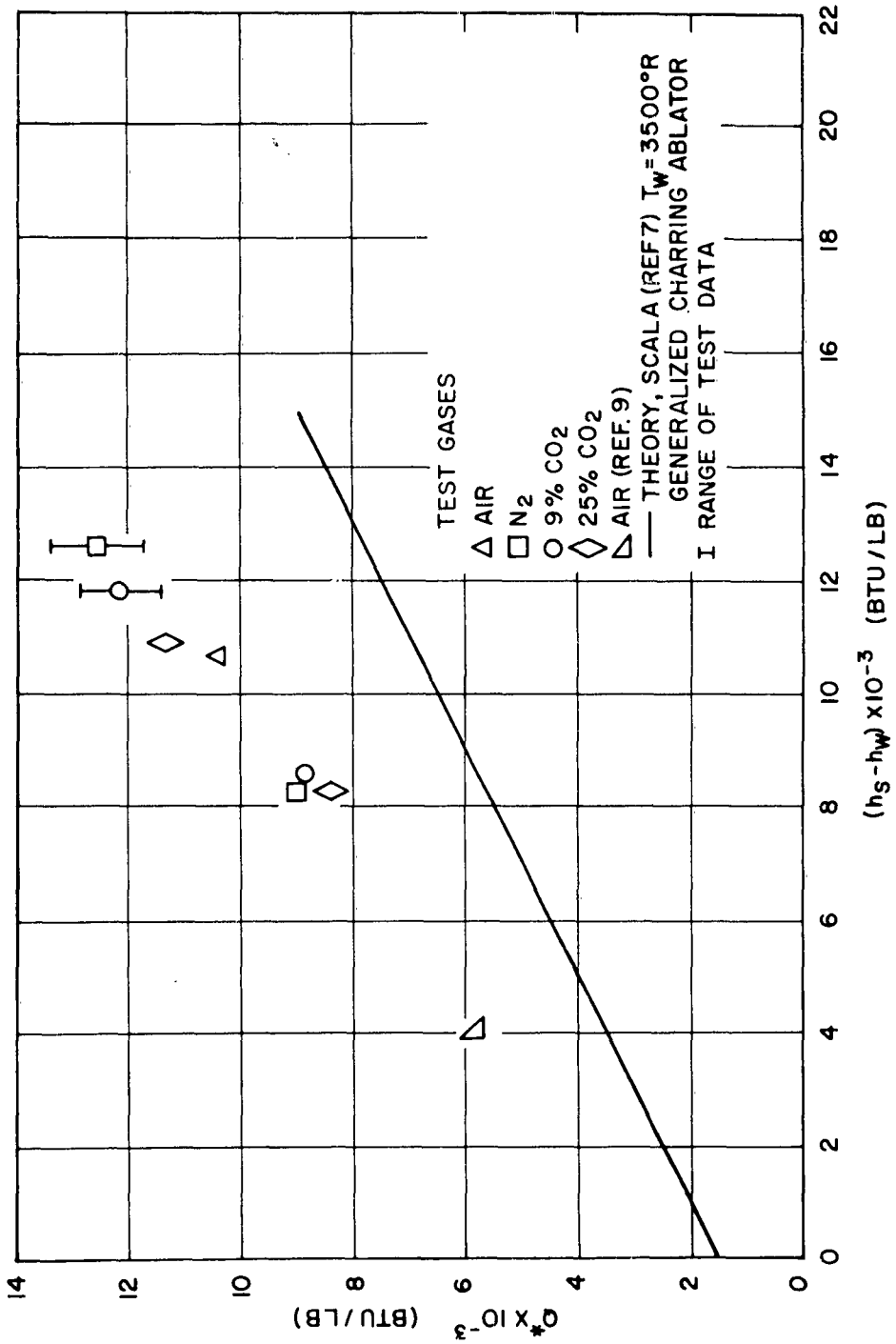

Figure 9. Heats of Ablation for Phenolic Nylon



SPACE SCIENCES LABORATORY
MISSILE AND SPACE DIVISION

TECHNICAL INFORMATION SERIES

AUTHOR R. A. Sheridan N. S. Diaconis W. R. Warren, Jr.	SUBJECT CLASSIFICATION Ablation Materials	NO. R63SD35
		DATE April, 1963
TITLE Performance of Several Ablation Materials in Simulated Planetary Atmospheres		G. E. CLASS I
		GOV. CLASS Unclassified
REPRODUCIBLE COPY FILED AT MSD LIBRARY, DOCUMENTS LIBRARY UNIT, VALLEY FORGE SPACE TECHNOLOGY CENTER, KING OF PRUSSIA, PA.		NO. PAGES 27
SUMMARY The thermal protection by ablation of vehicles entering simulated planetary atmospheres was the subject of the present study. The capability for such a study was provided by the Space Sciences Laboratory's tandem Gerdien arc -- a high purity, high enthalpy design, adapted to free jet testing. Well known ablation materials typical of three classes of ablators were tested in the arc-heated gas mixtures representative of Martian and Venusian atmospheres. The performance of each material in each gas mixture is evaluated and compared with similar performance in air. The results illustrate the severity of the entry problem for Mars and Venus relative to Earth re-entry for high heating rate or primarily steady state ablation situations. The effects of non-steady ablation and gas radiation on material performance were not studied.		

By cutting out this rectangle and folding on the center line, the above information can be fitted into a standard card file.

AUTHOR RA Sheridan ND Diaconis WR Warren, Jr.
COUNTERSIGNED C Smannal