

**UNCLASSIFIED**

**AD 410500**

**DEFENSE DOCUMENTATION CENTER**

FOR

**SCIENTIFIC AND TECHNICAL INFORMATION**

**CAMERON STATION, ALEXANDRIA, VIRGINIA**



**UNCLASSIFIED**

NOTICE: When government or other drawings, specifications or other data are used for any purpose other than in connection with a definitely related government procurement operation, the U. S. Government thereby incurs no responsibility, nor any obligation whatsoever; and the fact that the Government may have formulated, furnished, or in any way supplied the said drawings, specifications, or other data is not to be regarded by implication or otherwise as in any manner licensing the holder or any other person or corporation, or conveying any rights or permission to manufacture, use or sell any patented invention that may in any way be related thereto.

10  
REPORT 406

REPORT 406

ADVISORY GROUP FOR AERONAUTICAL RESEARCH AND DEVELOPMENT

64 RUE DE VARENNE, PARIS VII

REPORT 406

*scale 1*

410500

**THE CASE FOR ADAPTIVE CONTROLS**

by

M. A. OSTGAARD, E. B. STEAR and P. C. GREGORY

JULY 1962

DDC  
RECEIVED  
JUL 23 1962  
TISIA B

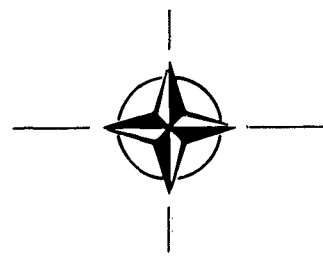

**NO OTS**

NORTH ATLANTIC TREATY ORGANIZATION

410500

CATALOGUED BY DDC

~~410500~~

AS AD No. \_\_\_\_\_

REPORT 406

NORTH ATLANTIC TREATY ORGANIZATION  
ADVISORY GROUP FOR AERONAUTICAL RESEARCH AND DEVELOPMENT

THE CASE FOR ADAPTIVE CONTROLS

by

M.A.Ostgaard, E.B.Stear and P.C.Gregory

This Report was presented at the Twenty-First Meeting of the Flight Mechanics  
Panel of AGARD, held in Paris, 6-10 July 1962

## SUMMARY

This paper attempts to show that adaptive control systems are practical, that they have lived up to expectations, and that they represent a significant advance over the conventional linear control systems. To do this the original problems which led to the initiation of applied research effort on adaptive flight control systems and the expected solutions from this research are reviewed along with certain pertinent historical aspects of linear feedback control theory. A typical flight control problem for re-entry vehicles is described, the conventional linear and the adaptive solutions to this problem are discussed in detail, and a practical mechanization of an adaptive flight control system for this application is described in some detail. Also some other promising adaptive techniques and their expected potential are discussed.

Finally, some closing arguments are given to complete the 'Case for Adaptive Control'.

## SOMMAIRE

Ce rapport a pour but de montrer que les systèmes de commande adaptifs sont pratiques, qu'ils ont rempli les prévisions et qu'ils représentent une avance importante vis-à-vis les systèmes de commande linéaires classiques. A cette fin les auteurs passent en revue les premiers problèmes rencontrés qui ont conduit à la mise sur pied d'efforts de recherches appliquées en vue de l'étude de systèmes de commande en vol adaptifs, ainsi que les solutions auxquelles on espère arriver par suite de ces recherches. Ils indiquent également certains aspects historiques qui y ont rapport relatifs à la théorie de la commande linéaire à réaction. Un problème type de la commande en vol qui se pose pour les véhicules de rentrée est décrit, la solution linéaire classique et la solution adaptive de ce problème sont très amplement traitées et une mécanisation pratique d'un système de commande en vol adaptif destiné à cette application est exposée en quelque détail. Sont également examinées certaines autres techniques adaptives prometteuses, avec une indication de leurs possibilités escomptées.

En conclusion, quelques arguments sont présentés pour terminer 'la défense du système de commandes adaptif'.

629.13.014.5

681.3

## CONTENTS

	Page
SUMMARY	ii
SOMMAIRE	ii
LIST OF FIGURES	iv
1. INTRODUCTION	1
2. HISTORICAL SKETCH	2
3. DESCRIPTION OF A TYPICAL PROBLEM	6
4. THE CONVENTIONAL LINEAR APPROACH	7
5. THE HIGH LOOP GAIN ADAPTIVE APPROACH	8
6. PRACTICAL MECHANIZATION	9
7. OTHER ADAPTIVE TECHNIQUES	11
8. CONCLUSIONS	13
ACKNOWLEDGEMENTS	14
REFERENCES	14
FIGURES	16
DISTRIBUTION	

## LIST OF FIGURES

	Page
Fig.1	Basis for derivation of Equation (1) 16
Fig.2	Model used for some of the analysis (see Section 2) 16
Fig.3	Basic configuration used in high loop gain adaptive system described in Section 3 17
Fig.4	Example of type of system with closed-loop responses independent of vehicle characteristics 17
Fig.5	Table of expected variations of vehicle characteristics in typical re-entry problems for a representative set of flight conditions 18
Fig.6	Pole-zero plot of vehicle transfer function (Equation 3) showing variation of vehicle characteristics 19
Fig.7	M-H MB-5 Autopilot - McDonnell F101B 20
Fig.8	Pitch axis block diagram 21
Fig.9	Gain computer loop 22
Fig.10	Variable gain amplifier characteristic 23
Fig.11	Pitch rate adaptive loop 24
Fig.12	Root loci for Case 1 25

## THE CASE FOR ADAPTIVE CONTROLS

M. A. Ostgaard\*, E. B. Stear\* and P. C. Gregory\*

### 1. INTRODUCTION

In 1955, the Flight Control Laboratory at the Wright Air Development Center initiated an applied research program, the objective of which was to demonstrate that the concepts in the infant field of adaptive controls could be practically applied to the design and development of automatic flight controls for manned aircraft. This was the first known attempt to practically use these concepts which were then considered of only academic interest. Since the publishing of the results of the initial successes in 1959 the field has matured rapidly and is now in a fairly advanced state of development. A great many adaptive control techniques have been conceived and evaluated in varying degrees of detail<sup>1-6</sup> including actual flight demonstrations in some cases<sup>1, 2, 5, 6</sup>. In general these flight demonstrations have been fairly successful and the recent X-15 flight tests have been very successful. To those who have been associated with this applied research program there is no doubt that adaptive flight control systems have lived up to expectations, that they are practical, and that they represent a significant advance over the conventional linear flight control systems now in widespread use.

Of course any skeptic<sup>†</sup> who has not been associated with this applied research program will undoubtedly want to know the basis for these conclusions. In this Report an attempt to provide the basis in detail will be made. If this attempt is successful, then it should represent a good 'Case for Adaptive Control'. It should also provide answers to some of the questions raised by the inevitable critics of research on adaptive control systems<sup>7</sup>.

In order to properly motivate the remainder of the paper, a brief historical sketch of some aspects of flight control systems (stability augmentation systems in particular) is given in Section 2 along with a review of some of the pertinent historical aspects of linear feedback control theory. In Section 3 the pertinent aspects of a typical flight control problem for manned re-entry vehicles are described. This is followed by Sections 4 and 5 which are devoted to a discussion of the conventional linear<sup>††</sup> and adaptive approaches to this type of problem respectively. A practical mechanization of an adaptive flight control system which will handle the problem outlined in Section 3 is discussed in some detail in Section 6. Section 7 considers some adaptive techniques, other than those discussed in Section 6, from the point of view of their potential relative to current and anticipated flight control problems. Finally some closing arguments are given in Section 8 to complete 'The Case for Adaptive Control'.

---

\* Flight Control Laboratory, Aeronautical Systems Division, Air Force Systems Command, United States Air Force, Wright Patterson AFB, Ohio, U.S.A.

† The term 'skeptic' as used here means 'any good control engineer'.

†† The conventional linear approach is assumed to result in a gain scheduled system.

## 2. HISTORICAL SKETCH\*

For many years certain elements of flight control systems for aircraft were very simple systems consisting of cables which directly connected the control stick and rudder pedals to the control surfaces. The dynamic response of the aircraft to control stick inputs was determined by the aircraft's configuration and flight condition and the pilot simply accepted what the aerodynamicist and structural engineer provided. Then in the late 1940's and early 1950's aircraft began operating over significantly increased ranges of speed and altitude. The effect of this expansion of the flight profile on aircraft flight control systems was twofold. First, power controls were introduced to handle the large increases in control surface hinge moments encountered on these new aircraft. Second, and of much more significance in this paper, stability augmentation systems were introduced to provide some artificial damping of the aircraft's 'short period' dynamic response to control stick inputs because the aerodynamicist and structural engineer were no longer able to provide sufficient inherent damping over the flight profile and still maintain acceptable aircraft mission performance. Of course once feedback systems (stability augmentation) were introduced, extensive control of the vehicle's 'short period' response became possible and the possibilities were rapidly explored. For reasons of flight safety, these stability augmentation systems were designed with limited authority which could be overridden by control stick inputs.

These two additions to the earlier flight control systems made possible the design of acceptable flight control systems for many aircraft, including modern experimental aircraft<sup>6</sup>, and they were widely adopted. However, the flight profile of operational aircraft continued to expand and, as a result, even the addition of such stability augmentation systems was not sufficient to achieve acceptable dynamic response because of the extreme variation in aircraft dynamics over the flight profile. The 'obvious' solution to this problem was to adjust the gains of the stability augmentation system as a function of measured air data such as altitude, Mach number, dynamic pressure, etc. This solution was adequate from a performance standpoint if the variable gains were properly adjusted and it was used in a number of aircraft beginning in the early to mid 1950's. However, it had several serious disadvantages and an applied research program in adaptive control systems was initiated to try to discover some control techniques with equivalent or better performance but without the disadvantages. Just what these disadvantages were is well summarized in the introduction to an earlier report<sup>1</sup>. To quote:

'During 1955, there was a growing realization that development programs for tailoring flight control systems to particular aircraft were becoming exceedingly complex and were requiring a great deal of research time. Airplanes were not being provided with a complete flight control system until two or more years after the airplane had first flown. Several factors were responsible for this condition. New aircraft were flying at higher altitudes and through greater speed ranges. These greater extremes were causing wider changes in the basic airplane's flight characteristics from one flight condition to another. Also, flight conditions were reached about which insufficient information was available.

---

\* This is a sketch and no attempt at completeness has been made.

These changes in airplane characteristics require corresponding adjustments of the control system parameters to maintain the response of the aircraft-control system combination relatively constant. If sufficient information about the aircraft characteristics for all the flight conditions is available when the control system is being designed, the required adjustments could be calculated for the control system. These adjustments could then be scheduled to take place based on the measured flight condition; for instance, when the altitude, Mach number or dynamic pressure ( $q$ ) reached a certain value, the gain of the servo amplifier could be increased or decreased a pre-determined amount. It is important to realize that this type of adjustment is an open-loop adjustment. If the adjustment scheduled to take place was not just right, due possibly to poor data, miscalculation, or some unforeseen change in the aircraft configuration, or even aging of system components, we still get the adjustment even though the response may become worse because of it. (In contrast, a closed-loop adaptive system would keep adjusting until the desired response was reached.)

Several important points about an open loop adjustment should be emphasized at this time. First, quite accurate and detailed information about the aircraft characteristics is required for the entire flight régime. Second, the capability must exist for measuring the air data for all conditions. Third, the calculation of all the necessary adjustments requires a considerable amount of time and must be confirmed by extensive flight test, and fourth, the end result is a system being adjusted in an open loop fashion with its attendant possible errors.

By the fall of 1955, it was becoming difficult to meet some of the requirements mentioned previously. First, less detailed information was available on the newer vehicles being planned. Second, the vehicles would be operating in environments which would make air data measurements quite unreliable if not altogether impossible. Third, the control system would be needed on the first flights, and fourth, the possibility of errors due to open-loop adjustment could compromise the mission.'

It should be emphasized at this point that the question as to whether or not adaptive flight control systems have lived up to expectations is essentially a question of *whether or not they have eliminated some or all of the above stated disadvantages* of conventional linear flight control systems. Further, it should be emphasized that these disadvantages concern *a lot more than dynamic response*; e.g., the time to design and 'calibrate' the system, the air data requirements, etc.

In the same report it is noted that in late 1955 'there was no experience of any kind, either practical or theoretical, on systems that automatically adjust themselves in a closed-loop fashion. However, there was some experience in attempting to design linear control systems whose responses were relatively independent of vehicle characteristics'. It is further stated that in practice this approach failed 'because of system non-linearities and aeroelasticity'.

Because of its direct relevance to the remainder of this paper, it is appropriate and important to examine in some detail this 'experience' in designing 'linear control systems whose responses are relatively independent of vehicle characteristics'. This 'experience' apparently began in the early 1930's in the communications industry with the work of H.S. Black<sup>9</sup>. The problem here was to obtain reasonably constant amplification from a tandem connection of a great many amplifiers (such as might be encountered in a carrier-in-cable system) even though the amplification of each amplifier varied

considerably. Black discovered that if excess gain was available, then this problem could be resolved and a reduction in modulation products\* achieved by applying stabilized feedback to the amplifier. He states<sup>9</sup>, 'However, by building an amplifier whose gain is deliberately made, say 40 decibels higher than necessary (10,000 fold excess on energy basis), and then feeding the output back on the input in such a way as to throw away the excess gain, it has been found possible to effect extraordinary improvement in constancy of amplification and freedom from non-linearity'. He goes on to say that, 'It is far from a simple proposition to employ feedback in this way because of the very special control required of phase shifts in the amplifier and feedback circuits, not only throughout the useful frequency band but also for a wide range of frequencies above and below this band'. This obviously is a reference to the problem of stabilizing the feedback amplifiers. In his paper, Black reports the results of a field trial in which seventy amplifiers were connected in tandem and he states that 'The results of this trial were highly satisfactory and demonstrated conclusively the correctness of the theory and the practicability of commercial application'<sup>†</sup>. Black also introduced a measure of the constancy of amplification which still appears in modern textbooks<sup>11</sup> where it is generalized and termed sensitivity.

This pioneering work by Black and Nyquist was continued by Bode whose work is summarized in his excellent book<sup>12</sup>. Bode considers the question of sensitivity in considerable detail and develops several theorems which are applicable to the sensitivity aspects of feedback amplifier design in particular and feedback systems in general. This work has been recently re-examined, interpreted, and generalized in a way as to make it directly applicable to and of use for control system design problems<sup>13, 14</sup>.

In essence, the design philosophy used by Black and his successors is simply to use as large a loop gain as possible (consistent with stability considerations) over the bandwidth of interest. That this will achieve the desired reduction in variation of amplification follows from Equation (1) which Black derived based on Figure 1.

$$\left[ \frac{\delta A_F}{A_F} \right]_{\mu} \doteq \frac{1}{1 - \mu\beta} \left[ \frac{\delta \mu}{\mu} \right] \quad (1)$$

It is seen from Equation (1) that normalized variations in  $\mu$  as reflected in normalized variations in  $A_F$  are reduced by a factor of  $1/(1 - \mu\beta)$  which can be quite small if the loop gain  $\mu\beta$  can be made large. This basic design philosophy will be encountered again in the following Sections.

In addition to the early 'experience' in the communications industry, there was also some 'experience' in the flight control industry prior to Fall 1955<sup>15-17</sup> and it is probably this 'experience' which Rath<sup>1</sup> referred to in the quotation given above. The original work here<sup>15, 17</sup> involved the use of a model as shown in Figure 2. The response of the model is compared with the response of the vehicle and the error,  $\epsilon_2$ ,

---

\* He further found that power supply noise, envelope delay, and delay distortion were also simultaneously reduced.

† It is interesting historically to note that Nyquist developed his well known stability criterion<sup>10</sup> to explain some of the unexpected results concerning stability in Black's early experiments with feedback amplifiers<sup>9</sup>.

is fed back to the vehicle input through the transmittance  $K_3G_3^*$ . The closed-loop transmittance of this system is

$$\frac{X_0}{X_1} = K_2G_2 \left[ \frac{1 + (1/K_2G_2K_3G_3)}{1 + (1/K_1G_1K_3G_3)} \right] \quad (2)$$

and it is seen that, if  $K_3G_3$  is large over the bandwidth of interest, then the closed-loop response is essentially that of the model independent of the vehicle transmittance  $K_1G_1$ . This is just an example of the basic philosophy of Black of using high loop gain to achieve the desired closed-loop transmittance invariance in the presence of variations in vehicle transmittance; but, it was apparently not recognized as such by Campbell and Prince<sup>15, 17</sup>. Later it was realized that the configuration shown in Figure 2 is essentially equivalent to that shown in Figure 3 (see Refs. 16 and 7) and this is the basic configuration used in the adaptive system discussed in Section 5.

In the same proposal<sup>15</sup>, Campbell also discusses the possibility of adjusting  $K_3$  as a function of  $\epsilon_2$ . This idea has been found to be reasonably fruitful as will be seen in Section 7.

If as implied above, these high loop gain techniques have the capability of achieving relatively invariant closed-loop responses in the presence of vehicle response variations, the question arises as to why the 'obvious' solution of using systems whose gains were adjusted as a function of air data was adopted instead of high loop gain systems. There were several reasons for this. First, prior to this time, stability augmentation systems were designed as simple gain-stabilized systems with maximum gain stability margins consistent with achieving some increase in vehicle short period damping. The reason for this philosophy was the fear of instability and the problem of reliability. Also, the vehicles themselves could be flown without the stability augmentation system being used. Further, the mention of lead networks was met with the reply that major noise problems would accompany their use and, hence, they should be avoided. This could have been due to the fact that at that time there was, perhaps, incomplete understanding of network compensation techniques and their advantages and disadvantages on the part of flight control system engineers, a lack which was largely overcome in later gain scheduled systems such as the MB5 autopilot which use high gains and lead networks. Finally, the state of the art hardwarewise as regards electronic components used in compensation networks was not nearly so advanced as at present. In any case, the flight control industry adopted the use of simple stability augmentation systems whose gains were adjusted as functions of air data so as to achieve maximum gain stability margin consistent with the required short period response over the flight envelope. However, the difficulties with this 'obvious' solution soon forced a re-examination of the design situation, which led to the development of adaptive flight control systems.

In the early work on adaptive flight control systems, as reported in the proceedings of the conference held at Wright Field in January 1959<sup>2</sup>, the virtues of high

---

\* This approach is just a special case of the conditional feedback system<sup>18</sup>.

loop gain systems began to be fully recognized. Systems of the type shown in Figure 4 were found to have closed-loop responses which were quite independent of the vehicle characteristics. The reason for this was that the loop gain of the system was very large and the benefits of this high loop gain were readily apparent. In the systems studied, the linear loop gain was such that the linear system was unstable and limit-cycle oscillations developed. The amplitude of these limit-cycle oscillations was limited by the action of the non-linear element and in most cases it was of such a small magnitude that its presence in the output was unobjectionable. A variation of this type of system which has proven highly satisfactory is discussed in detail in Sections 5 and 6.

Other variations of this high loop gain type of adaptive systems can be found in the conference proceedings, as well as some other types of adaptive control techniques, the most promising of which are discussed somewhat in Section 7. A fairly thorough treatment of analysis methods for these limit cycling high loop gain systems can be found in some recent publications<sup>19, 20</sup>.

It should be noted that the *basic philosophy of design of these high gain adaptive systems is essentially that advocated by one of the critics of adaptive control*<sup>7, 13, 14</sup>. However, the details as to how the high loop gain is achieved and 'stability' is maintained differ. The true significance of these detailed differences is still somewhat open to discussion and the arguments pro and con will not be presented here. It is expected that a fairly complete comparison will be published within the next year.

To summarize then, it can be said that the research program in adaptive flight control systems demonstrated convincingly the virtues of high loop gain systems and gave birth to a mechanized class<sup>6</sup> of such systems which have lived up to expectations in actual flight test for such severe applications as the X-15.

It is true that the performance of these high loop gain systems\* is limited by the effects of time delays, aeroelasticity, system non-linearities, and the non-minimum phase character of some vehicles, but that does not mean the approach failed as implied by Rath. On the contrary, despite these limitations the approach has been quite successful. Work is continuing on other more advanced adaptive flight control techniques which by applying greater computation, will attempt to overcome some or all of the limitations mentioned above.

### 3. DESCRIPTION OF A TYPICAL PROBLEM

As noted in Section 1, this section is devoted to a description of those aspects of a typical re-entry control problem which are pertinent to a discussion of adaptive flight control systems. Only the pitch axis case for the stability augmentation mode will be considered because it is reasonably representative of the complete system.

---

\* This is true of the limit cycling high loop gain adaptive systems as well as the straight linear high loop gain system actually referred to by Rath.

The short-period approximation to the general aerodynamic equations of motion using linearized aerodynamics is given in Equation (3)\*:

$$\frac{\dot{\theta}}{\delta} = K\dot{\theta} \frac{T_a S + 1}{\frac{s^2}{w_a^2} + 2 \frac{\zeta_a}{w_a} S + 1} \quad (3)$$

The quantities  $K\dot{\theta}$ ,  $T_a$ ,  $\zeta_a$  and  $w_a$  are functions of the vehicle's inertia characteristics and stability derivatives and for a typical re-entry vehicle they vary considerably over the flight profile and as a function of the normal angle of attack. The variation to be expected in typical re-entry problems is indicated in Figure 5, which gives a table of their values for a set of representative flight conditions. As can be clearly seen, the vehicle characteristics vary drastically over the expected flight régime. This variation is even more graphically illustrated by Figure 6, which is a pole-zero plot of the vehicle transfer function Equation (3). It is noted that the vehicle has very low inherent damping at all flight conditions and that the vehicle gain,  $K\dot{\theta}$ , varies by a factor of 1000 to 1.

Now that the vehicle characteristics have been described, a typical set of specifications of response to commands and gust disturbances will be given. Since specifications can and do vary considerably from one application to another, this set should not be taken too rigorously. However, it does represent what is typically expected and achievable in the way of closed-loop system response.

Considering first the response to commands, the system is required to have less than 25% overshoot and to damp to one-eighth amplitude or less in one cycle when subjected to a step input. Furthermore, the response time (time to reach 90% of the commanded value) shall be less than three seconds. As far as gust disturbance response is concerned, the requirement is that such disturbances will be damped to less than one-fourth amplitude in one cycle. Finally, it is specified that full servo authority and full trim authority will be used by the stability augmentation system to provide full surface authority.

#### 4. THE CONVENTIONAL LINEAR APPROACH

While the unavailability of adequate air data sensors makes a conventional linear approach to the problem sketched in Section 3 unfeasible at the present time, it is useful to discuss this approach as if such sensors were available. Such a discussion will cover the possibility that such sensors become available in the future and it will also indicate what is involved in its use in other applications where such sensors are available.

The control system which results from the application of the conventional linear approach to flight control problems of the type discussed in Section 3 is illustrated by Figure 7. This is the block diagram of the conventional pitch rate linear flight

---

\* No aeroelastic effects or tail-wags-dog effects have been included, for reasons of simplicity, but they are important in many applications and limit the performance of high loop gain systems.

control system for the vehicle which was used as a testbed for the development of the high loop gain adaptive system being currently tested in the X-15\*. While this particular system might very well not be adequate for the problem discussed in Section 3, it is quite satisfactory for illustrative purposes.

For our purposes it should be noted that seven gains are required to be scheduled as functions of indicated airspeed, true airspeed, Mach number, and altitude. To handle the problem posed in Section 3 would probably require at least as many gains to be scheduled and more complex schedules for each gain. The determination of the gain schedules to be used requires extensive flight testing to define vehicle characteristics as a function of flight conditions followed by considerable calculation and computer simulation. The end result is a system which performs quite well, but has all the disadvantages stated by Rath in the quotation given in Section 2.

The detailed design procedure for arriving at the configuration given in Figure 7 and the choice of gains to be scheduled is standard and fairly well known. Hence it will not be given here.

## 5. THE HIGH LOOP GAIN ADAPTIVE APPROACH

There are undoubtedly many variations of high loop gain adaptive flight control systems which will handle the problem posed in Section 3. One of these which is definitely known to be able to do so, and to be able to perform the other usual autopilot functions as well, is illustrated in Figure 8. The system includes both aerodynamic and reaction controls. The gain computer loop and the variable gain characteristics are shown in Figures 9 and 10 respectively. As is revealed by direct comparison with Figure 7, all gains which in the conventional system are adjusted as functions of air data have been removed and in their place is substituted one non-linear gain which is adjusted as a function of servo response. This was made possible by breaking with tradition and utilizing high loop gain. Thus, the need for air data and the tailoring of gain schedules to match the vehicle characteristics are avoided and most of the disadvantages of conventional linear systems are overcome. It is this fact which forms the basis for the statements that adaptive flight control systems have lived up to expectations and that they represent a significant advance over the conventional linear flight control systems.

Since these types of systems are fairly new, it is probably worthwhile to discuss their method of operation and the basis for their design in some detail. For this purpose it will be useful to consider Figure 11. This figure is a block diagram (complete with transfer functions) of the stability augmentation loop indicated in Figure 8. The method of operation of the system is as follows. The gain computer increases the gain of the system until the system becomes unstable at which time a limit cycle develops. The amplitude of this limit cycle at the servo output is compared with the set point in the gain computer (see Fig.9) and the non-linear gain is adjusted until the two are equal. This type of operation gives high loop gain

---

\* The gain scheduled inner loop portions of this conventional system were replaced by a high loop gain adaptive system of the type used in the X-15. This adaptive system proved highly satisfactory throughout extensive flight test evaluations.

with the system operating effectively at the neutral stability point, the amplitude of the resulting oscillation being carefully controlled by the gain computer and gain adjusting loop. The high loop gain achieved in this way produces a feedback portion of the system shown in Figure 11 whose bandwidth is several times larger than that of the model over the flight envelope providing only that the lead networks used for compensation are properly chosen\*. This leads to a system whose response is essentially that of the model and hence meets the specifications on response to command inputs. As far as gust response is concerned the closed-loop response of the system to disturbances is also well damped in addition to having a wide bandwidth with respect to command inputs. This is illustrated by the root locus plot of the system shown in Figure 12, for flight condition 1. The lead network and servo zeros are placed at  $-5$ ,  $-8.33$ , and  $-5$ , respectively so as to attract the locii originating at the vehicle poles and produce well damped closed loop short period poles with relatively small time constants†. The system is seen to be neutrally stable at  $K=12$  and has a pair of closed loop poles at  $32$  rad/sec when in normal operation at this gain value. Excitation of these modes by gusts is no serious problem here due to the action of the gain changer in controlling the amplitude of such oscillations. Of course gusts do have the undesirable effect of reducing loop gain through the action of the gain changer and this effect has been experienced in flight test. For more details regarding the operation and design of such high gain systems, the interested reader is referred to a recent paper and the references cited therein<sup>6</sup>. The mechanization of the system shown in Figure 8 is discussed in the next section.

## 6. PRACTICAL MECHANIZATION

A practical mechanization of the control system problem described in Section 3 imposes some severe requirements that must be satisfied without imposing undue design requirements on components. The most significant requirements that must be satisfied are, briefly:

- (a) Full utilization of the servo and trim authority demands a system design that will lend itself to fail safe operational redundant mechanization to achieve the required level of high reliability and fail safety. Further, this mechanization must lend itself to operational use and maintenance.
- (b) The system must be capable of adjusting or compensating quickly for rapid and wide variation in vehicle dynamic characteristics to satisfy the command and gust response requirements of Section 3.
- (c) The adjusting or compensating mechanism must be an implicit part of the system since there is no practical method of measuring external environmental parameters with which to adjust the system. Further, since very limited flight data exists for this régime the system must be able to cope with wide variations in predicted parameters.

---

\* This can be seen by sketching root locus plots for each flight condition throughout the flight envelope (see Fig. 12).

† This is just the compensation technique described by one of the critics of adaptive control systems in a recent paper<sup>13</sup>.

- (d) Since non-aerodynamic controls will be required for certain portions of the flight profile the system must incorporate the logic to automatically activate the reaction system and also blend aerodynamic and non-aerodynamic controls in a manner to provide acceptable response with minimum of reaction fuel expenditure.

The system selected is shown in Figure 8 in which the inner loop consists of a tight feedback system controlling some selected parameter of vehicle motion. The controller variable selected is pitch rate to satisfy the conditions of damping, command response and compatibility with possible outer loop modes which will not be discussed herein.

The desired action is to force the response of the output  $\theta$  to duplicate the model output  $\theta_m$ . Practically, this can be achieved if the response of the inner loop is several times as fast as the model response. This rapid response of the inner loop is achieved by using series lead compensation in conjunction with high forward loop gains. The method of providing these high loop gains consistent with stability was discussed in Section 5 and will not be repeated here. The loci of roots of this system are plotted in Figure 12 for one case of conditions.

Variations in control mode capabilities are also shown in Figure 8, one example being the capability to command a combination of pitch rate and normal acceleration. Flight experience has shown distinct advantages in terms of pilot response in conditions where predetermined g-maneuvers must be performed or where 'g' is a primary control variable. This same flight experience has shown that a system mechanization of this type reduces to a high degree the need for devising special piloting techniques. All pilot comments to date have been very favorable.

A Dual Redundant Adaptive Controller is employed to provide fail safety plus continuous operation of the adaptive flight control system in the event of a single failure. The adaptive system automatically changes its gain and compensates for any open type of failure. Shorted types of failures are compensated through specific limiters and isolation of dual channel circuits. Signal and gain compensation is available to compensate for a hard over failure in one channel. This illustrates only the concepts involved in utilizing adaptive techniques to compensate for component failures. A detailed discussion of the details involved, though desirable, is beyond the scope of this report. Nevertheless the concepts described are proving successful in current designs and in flight evaluations.

The use of the adaptive system gain changer to provide reaction control activation logic has proven quite simple and effective. The typical mechanization presently in use consists essentially of utilizing the 80% of maximum point on the gain changer to activate the system, after which time the reaction system is available for use on demand basis. To overcome the possibility of de-activation of the system due to a rapid servo response which can cause a reduction in gain below the 80% value a lower point was selected for de-activation. This is an attribute of an adaptive system that has not received any comments in open literature. One possible explanation is that this problem has never been encountered in conventional system designs and, as a consequence, no equivalent design exists.

Very little has been said up to this point on physical components and practicability of circuit designs. Initially then, it may be well to compare the block diagrams of a conventional linear system (Fig.7) and a high gain adaptive system (Fig.8). From the physical component standpoint there is no significant difference. The sensor, actuator and basic electronic elements are the same. The adaptive system block diagram does include a reaction control capability which is not a part of the linear system. This capability was commented upon earlier in this discussion. Aside from this particular item there is no significant difference in component utilization. In both systems compensation networks are employed which further indicate similarity in electronic circuit design. The principal difference between the systems is the substitution of a non-linear gain which is adjusted as a function of servo response for the conventional open loop scheduled gains. No other physical changes in components are required other than the incorporation of an electronic model which is a relatively simple electronic circuit design.

There may be a question as to the physical design of the adaptive gain changing circuitry and its sensitivity to component tolerances and environments. This circuit, like any low level d.c. circuit, requires good quality electronic circuit design. However, designs to date indicate that the design is no more severe than a conventional high gain circuit. Conventional magnetic amplifier circuitry with low input impedances and low drift characteristics have proven very successful.

To summarize briefly, it can be stated that the adaptive mechanization is practical and imposes no more severe requirements on components or circuit design than conventional systems. Further, with a proper design approach these techniques will enable design of flight control systems that can provide desirable handling qualities with the necessary reliability capability.

## 7. OTHER ADAPTIVE TECHNIQUES

The preceding discussion has been restricted to the high gain technique in the interest of brevity to permit discussion of basic capabilities of this technique. Further, this technique has received considerably more applied research and flight evaluation effort upon which to base specific conclusions. Other adaptive techniques which are not as well developed but which possess potential capabilities are error switching, model reference and statistical-sampled data techniques. These techniques are discussed briefly from the standpoint of their potential application. The reader is referred to the references for further detail.

*The Error Switching Technique* was evolved via a variational calculus approach by Dommasch and Barron of DODCO, Inc. and represents one outgrowth of a number of years research effort by a number of researchers which has been applied toward development of systems that change their dynamic characteristics as a function of system error and/or its derivatives<sup>21</sup>. In principle this technique attempts to achieve the optimum response, as defined by the pre-filter model, by switching between two levels of gain in accordance with specified error and error rate criterion to force the response of the system to be identical to the model. This type of system has no requirement for measurement of system dynamics and as such could be classified as a predictive type since it attempts to predict and remove the error and its first derivative over a finite time period. This then makes the sensor (angular accelerometer) a significant

element in the operation of the system since its output is compared to the model  $\theta$  and the resultant error fed to the switching criteria. If the sensor natural frequency is low the resultant phase shift moves the switching criteria lines and establishes new criteria. To provide maneuvering response capabilities comparable to high gain techniques over a wide range of vehicle characteristics would necessitate an angular accelerometer with a natural frequency of approximately 30 cps. The principle of operation of this technique is basically similar to that of high gain systems in that if the bandwidth of the vehicle/control system is maintained several times greater than the model the transient response will be identical to the model dynamics.

Even though our present knowledge indicates possible limitations of this technique to aerodynamic vehicles unless methods are derived to relax accelerometer requirements, this technique has definite application where an error and error rate can be measured. A very possible application is attitude stabilization of an orbiting satellite where 30 cps rate gyros are readily available. Since the physical mechanization is simple and easily realizable this type of application is worthy of attention.

*The Model Reference Technique* represents another approach with distinct potentiality. In contrast to the high gain technique discussed in Section 5, the model and flight vehicle control system are in parallel and each receives the same input. The parameter adjustment mechanism, which can control multiple parameters, operates on the error between the flight vehicle control system response and the model response. The adjustment mechanism continuously changes the variable parameters (as a function of this error) so as to reduce this error or some even function or functional of it to a minimum value. In this manner the flight vehicle control system response is forced to duplicate the model response as closely as possible.

This technique has not received the attention the high gain technique has enjoyed previously due to certain hardware implications involved in the parameter adjustment. It has been observed that the adjustment of one parameter requires considerably more equipment than the high gain technique, including another model. Further, this complexity is essentially proportional to the number of parameters involved, which includes a model and a multiplier. The ability to meet present-day requirements with simple mechanization of the high gain types has undoubtedly caused relaxation of efforts in this technique.

Recent work in this area has, however, renewed interest in this technique<sup>6</sup>. It has been observed that any noise or disturbances on the input tend to aid in the operation of the system and do not degrade the performance as in the high gain technique<sup>6</sup>. Simulation results also indicate that noise or disturbances which enter the vehicle control system and not the model cause the control system to increase its ability to reject such noise or disturbances. Lack of noise or disturbance on the other hand provides no basis for parameter adjustments and thus sizable errors can build up. This again is in direct contrast with high gain techniques.

The fact that the model and flight control system are in parallel indicates that when the adaptive system is working properly the time constants of the model and flight control system are roughly equal and not considerably smaller as required by the series model of the high gain technique. This then indicates that systems using this model reference technique may be less susceptible to structural elasticity effects than the high gain technique. Even though this conclusion has not been

definitely established the problems associated with control of structurally elastic vehicles may warrant this approach, which may in the final analysis provide a simpler system, though initially it appears more complex.

*The use of Statistical Methods and Sampled Data Techniques* for self adaptation is very much in its infancy. Work in this area has been concentrated primarily on: (i) establishing feasibility of a process identification technique, based upon correlation calculations and sampling, for measuring the transfer function of an aerospace vehicle in flight; (ii) developing synthesis techniques for designing an optimum digital controller for the vehicle, when it is part of a closed-loop flight control system, which will achieve specified performance; and (iii) demonstrating in a full scale digital computer simulation the feasibility of combining the process identification technique and the synthesis technique to form the basis for a digital flight control system which can vary its characteristics to achieve optimum control over a wide range of dynamic and environmental conditions. Preliminary results are quite encouraging; however, considerably more work is required before definite conclusions can be formulated.

A logical question at this point may be the basis for pursuit of these more advanced digital techniques. The basic argument is essentially the same as for initial investigation of adaptive techniques, but, more significantly, recent advances in information theory, application of coding techniques<sup>2</sup> and technological developments in microminiaturization in the electronics field indicate large improvements in reliability capability<sup>22</sup>. Furthermore, recent work in neuristic element technology, self-organizing concepts and their potential application to flight control system designs indicate a definite need and trend toward utilization of digital mechanization of flight control systems. The increasingly severe requirements imposed by new systems for high reliability and long life also necessitate serious consideration of this latter and more promising approach.

## 8. CONCLUSIONS

By means of considering an actual typical re-entry control problem and referring to a current successful flight test program on the X-15, it has been conclusively shown that high loop gain adaptive flight control systems have lived up to expectations and do represent a significant advance over the conventional linear flight control systems by doing away with the need for air data and the expensive tailoring programs conventional systems require. An actual mechanization of a system capable of handling the typical problem posed was described to establish the fact that furthermore such systems are practical and can be mechanized. That the use of such high loop gain systems for flight control problems represents a break with tradition is pointed out and the history of the concept of using high gain to nullify the effects of variations of vehicle (plant) characteristics is traced back to 1934 to Black and the communications industry. Some other adaptive concepts which appear to offer some improvement over high loop gain adaptive systems in certain aspects of current interest are discussed briefly to indicate current effort and future trends.

Everything considered, it is felt that the above constitutes a winning 'Case for Adaptive Control'.

## ACKNOWLEDGEMENTS

The authors gratefully acknowledge the help received from the following people in the preparation of this paper: Mr. Stan Dominiak and Mr. Fred Taylor for preparation of figures, and Miss Ola Crutchfield, Miss Rose Moon and Mrs. Francis Rigio for typing of manuscript.

## REFERENCES

1. Rath, R.R. *Summary and Status of Adaptive Control System Programs.* WADC TN 58-330, ASTIA Document No. AD 205548, Sep. 1958.
2. Gregory, P.C. (Ed) *Proceedings of the Self-Adaptive Flight Control Symposium.* WADD TR 59-49, Jan. 1959.
3. Stromer, P. *Adaptive or Self-Optimizing Control Systems - A Bibliography.* IRE Transactions on Automatic Control, PGAC-4, No. 1, May 1959, pp. 65-68.
4. Mishkin, E. Braun, L. *Adaptive Control Systems.* McGraw-Hill Book Co., Inc., New York, 1961.
5. Wilson, G. *X-15 Will Test Adaptive Control Systems.* Aviation Week, Vol. 75, No. 21, Nov. 20, 1961, pp. 95-99.
6. Stear, E.B. Gregory, P.C. *Capabilities and Limitations of Some Adaptive Techniques.* Proceedings of 1962 National Aerospace Electronics Conference (NAECON), May 1962, pp. 644-661.
7. Horowitz, I. *Plant Adaptive Systems vs. Ordinary Feedback Systems.* IRE Transactions on Automatic Control, PG AC-7, No. 1, Jan. 1962.
8. Holliday, W. Hoffman, D. *Systems Approach to Flight Control.* Astronautics, Vol. 7, No. 5, May 1962, p. 36.
9. Black, H.S. *Stabilized Feedback Amplifiers.* Bell Telephone System Monograph B768. (Also in Electrical Engineering, Jan. 1934).
10. Nyquist, H. *Regeneration Theory.* Bell System Technical Journal, Vol. XI, July 1932, pp. 126-147.
11. Truxal, J. *Automatic Feedback Control System Synthesis.* McGraw-Hill Book Co. Inc., New York, 1955, pp. 120-127.
12. Bode, H. *Network Analysis and Feedback Amplifier Design.* D. Van Nostrand Company, Inc., New York, 1945.

13. Horowitz, I. *Fundamental Theory of Automatic Linear Feedback Control Systems.* IRE Transactions on Automatic Control, Vol. AC-4, No.3, Dec.1959, pp.5-19.
14. Horowitz, I. *Synthesis of Linear, Multivariable Feedback Control Systems.* IRE Transactions on Automatic Control, Vol. AC-5, No.2, June 1960, pp.94-105.
15. Campbell, G. *Proposal for Research to Determine the Feasibility of the Use of an Adaptive Servo to Improve Airplane Flight Characteristics.* Cornell Aeronautical Laboratory Flight Research Department Memo., Mar.1955, (Re-issued 17 June 1955).
16. Campbell, G. *Use of an Adaptive Servo to Obtain Optimum Airplane Responses.* Cornell Aeronautical Laboratory Report No.84, Feb.1957.
17. Prince, L. *An Adaptive Control System.* Minneapolis-Honeywell Internal Memo., May 1955.
18. Lang, G.  
Ham, J. *Conditional Feedback Systems - A New Approach to Feedback Control.* Trans. AIEE Vol.74, Part 2, July 1955, pp.152-161.
19. Gelb, A. *The Analysis and Design of Limit Cycling Adaptive Automatic Control Systems.* D.Sc. Thesis, Massachusetts Institute of Technology, Aug.1961.
20. Alex, F.  
Heermann, C. *Analysis of Two Non-Linear Flight Control Systems.* ASD TDR 62-369, Apr.1962.
21. Dommasch, D.O.  
Barron, R.L. *The Theory and Application of Optimum Limited Information Adaptive Flight Control Techniques.* WADC TR 59-468, Oct.1959.
22. Fleck, J.J.  
et alii *Research and Feasibility Study to Achieve Reliability in Automatic Flight Control Systems.* WADD TR 61-264, Mar.1961.

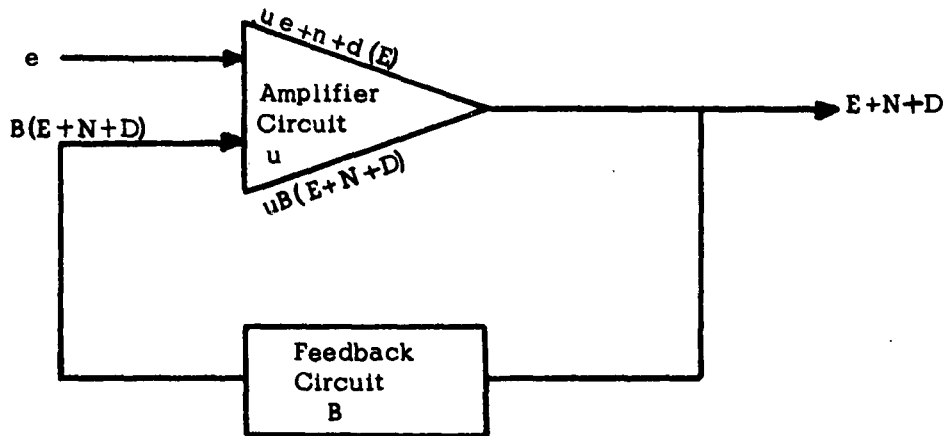

Fig.1 Basis for derivation of Equation (1)

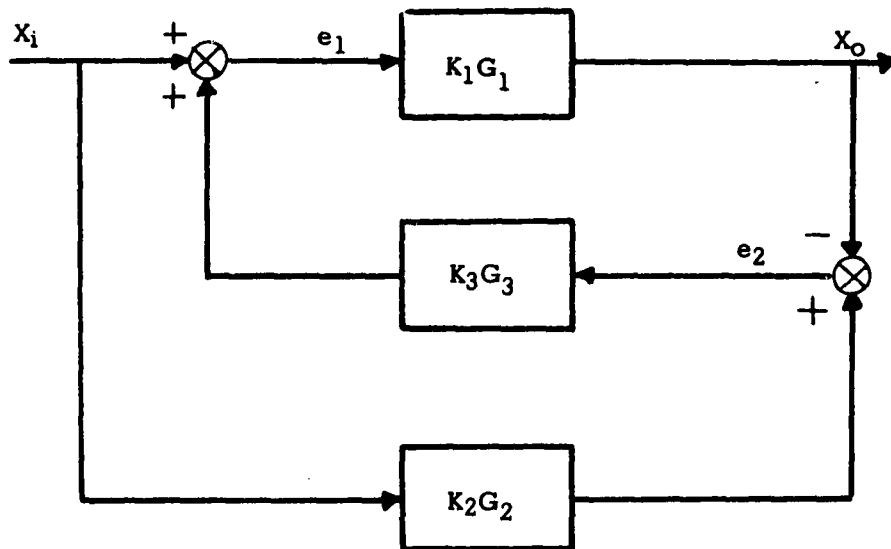

Fig.2 Model used for some of the analysis (see Section 2)

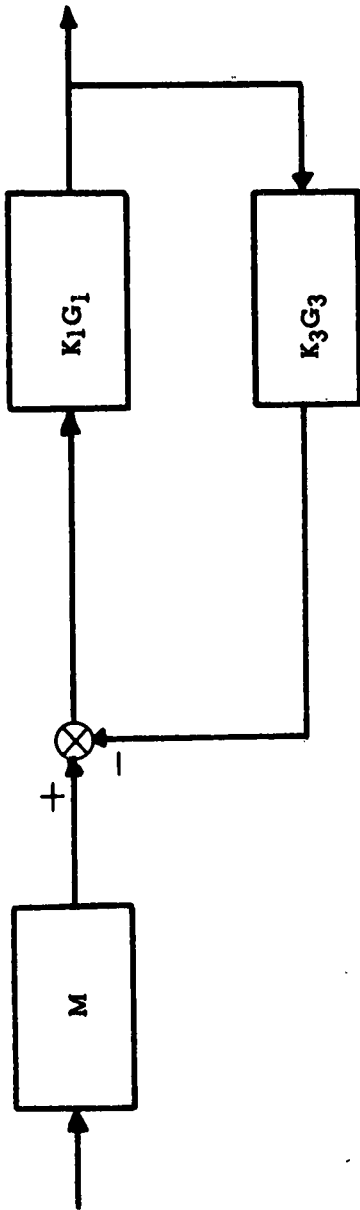

Fig. 3 Basic configuration used in high loop gain adaptive system described in Section 5

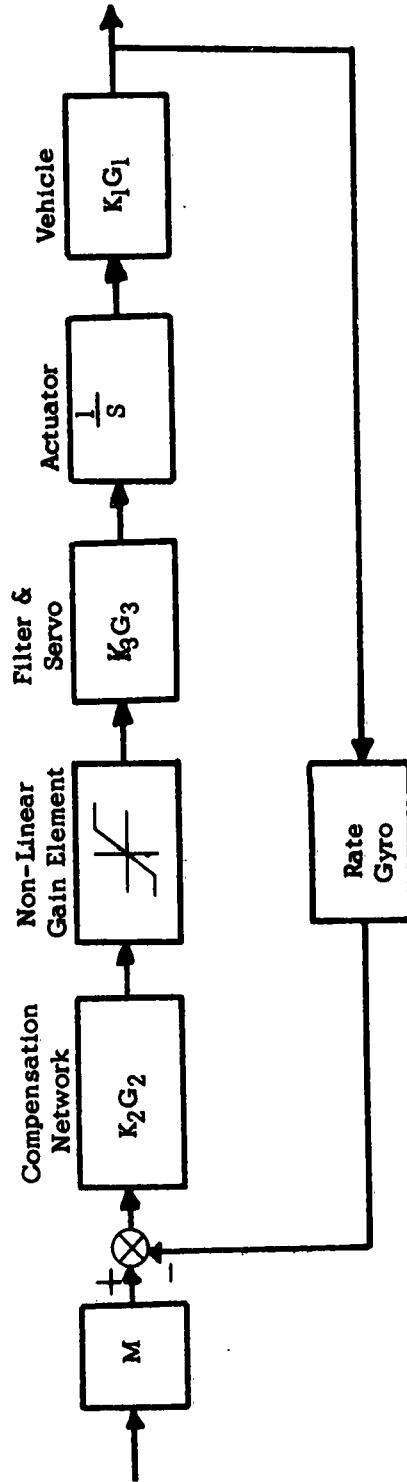

Fig. 4 Example of type of system with closed-loop responses independent of vehicle characteristics

Condition	Altitude	Mach Nr.	$-\frac{1}{Ta}$	$K_s$	$f a Wa$	$Wa$
1	35,000	0.3	-0.123	0.1066	0.2604	1.988
4	40,000	1.0	-0.282	0.312	0.445	2.972
5	40,000	1.0	-0.206	0.262	0.375	2.769
9	70,000	2.0	-0.088	0.0583	0.1052	2.631
13	100,000	4.0	-0.0366	0.0223	0.0396	1.919
16	140,000	6.0	-0.00794	0.00865	0.00823	0.8067
17	120,000	6.0	-0.0184	0.0198	0.019	1.203
18	120,000	6.0	-0.02585	0.0199	0.0276	1.859
21	60,000	5.0	-0.325	0.362	0.326	4.327
28	10,000	1.2	-2.07	1.950	2.49	7.492
29	10,000	1.0	-1.975	3.42	2.31	4.915
30	10,000	0.6	-0.955	2.03	0.943	2.5708
31	5,000	0.6	-1.163	2.92	1.113	2.550
32	0	0.2	-0.0356	0.00343	0.151	1.511
33	160,000	6.0	-0.00368	0.00394	0.0038	0.555

Fig.5 Table of expected variations of vehicle characteristics in typical re-entry problems for a representative set of flight conditions

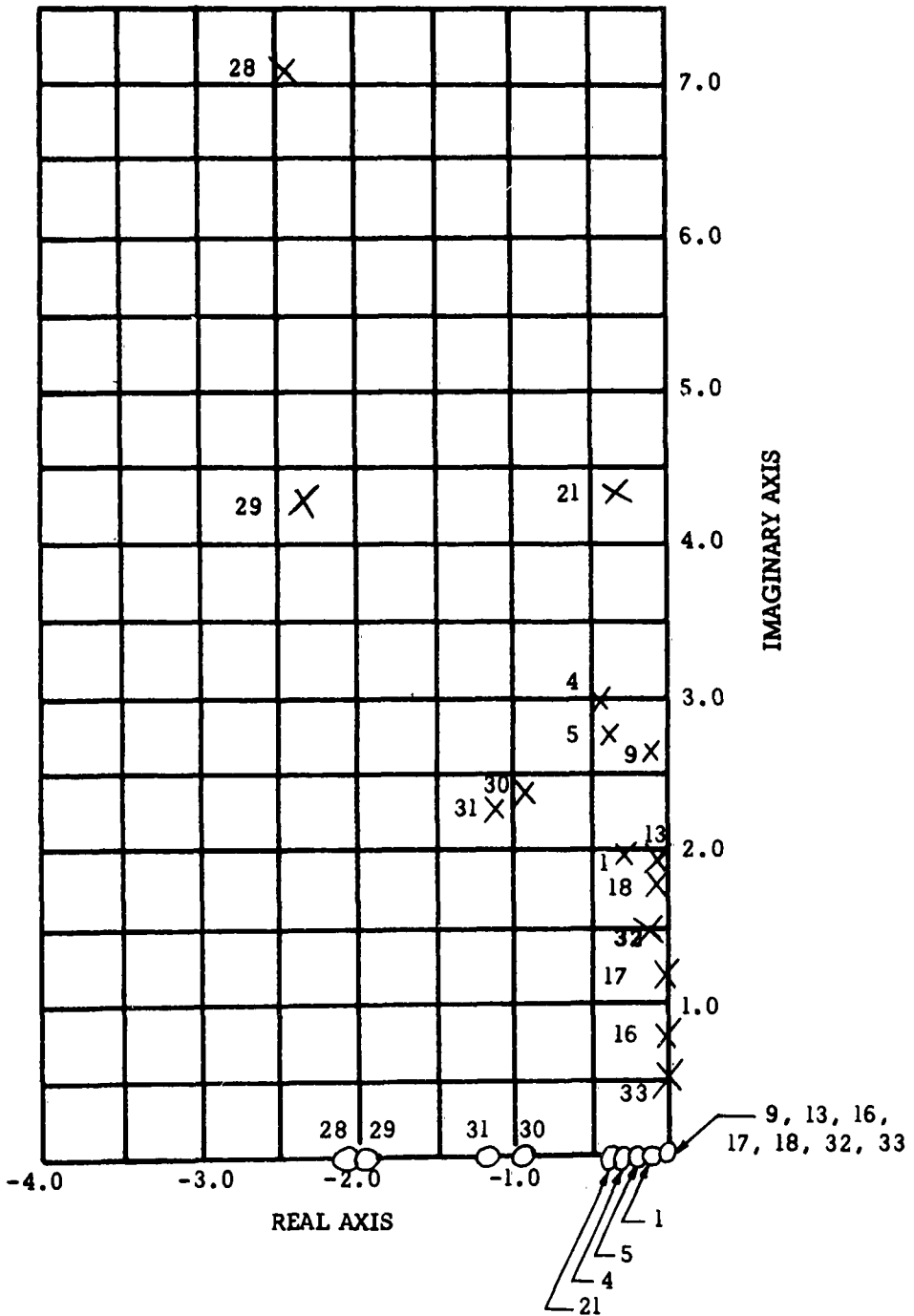

Fig.6 Pole-zero plot of vehicle transfer function (Equation 3) showing variation of vehicle characteristics

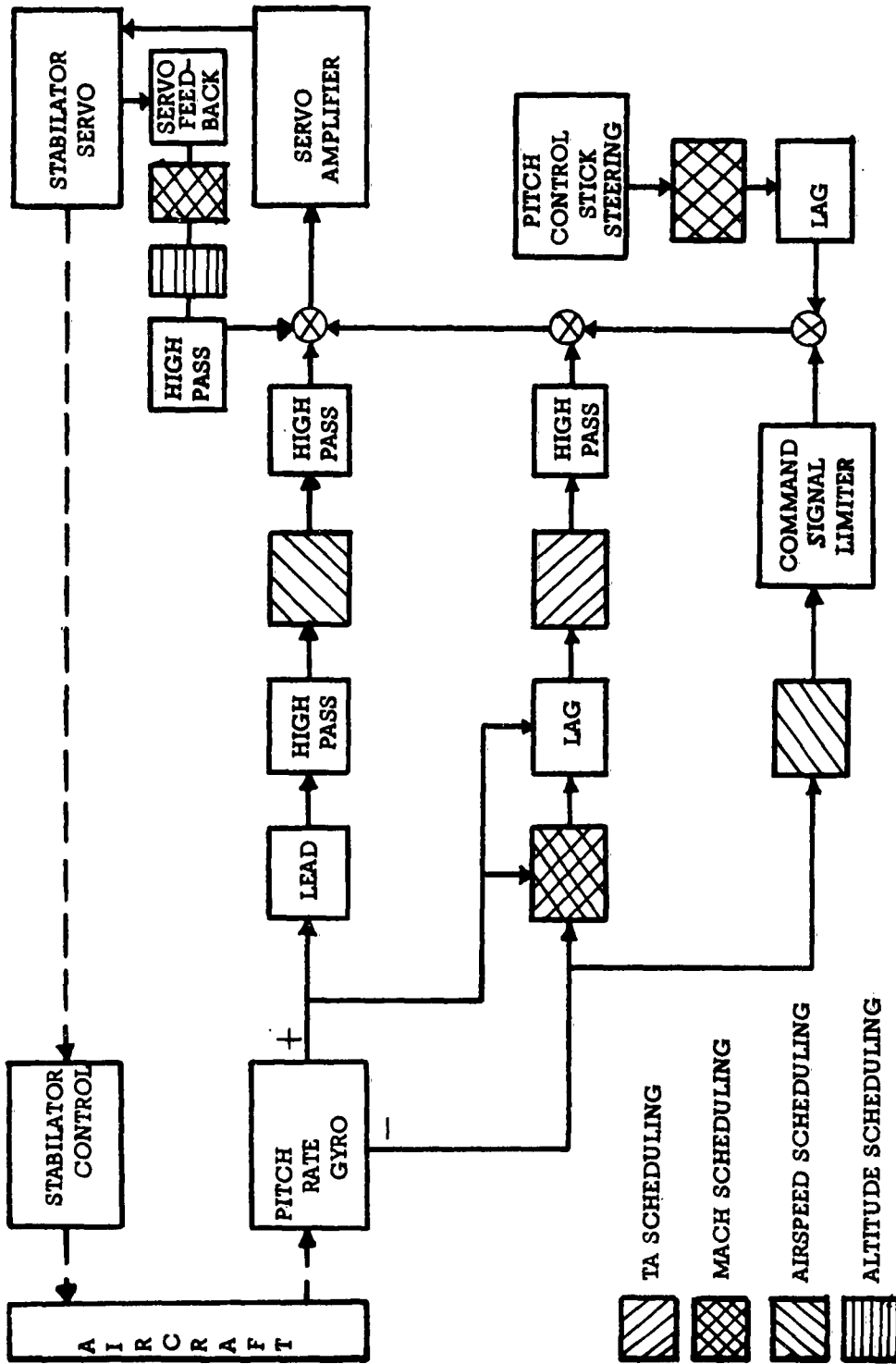

Fig. 7 M-H MB-5 Autopilot - McDonnell F101B

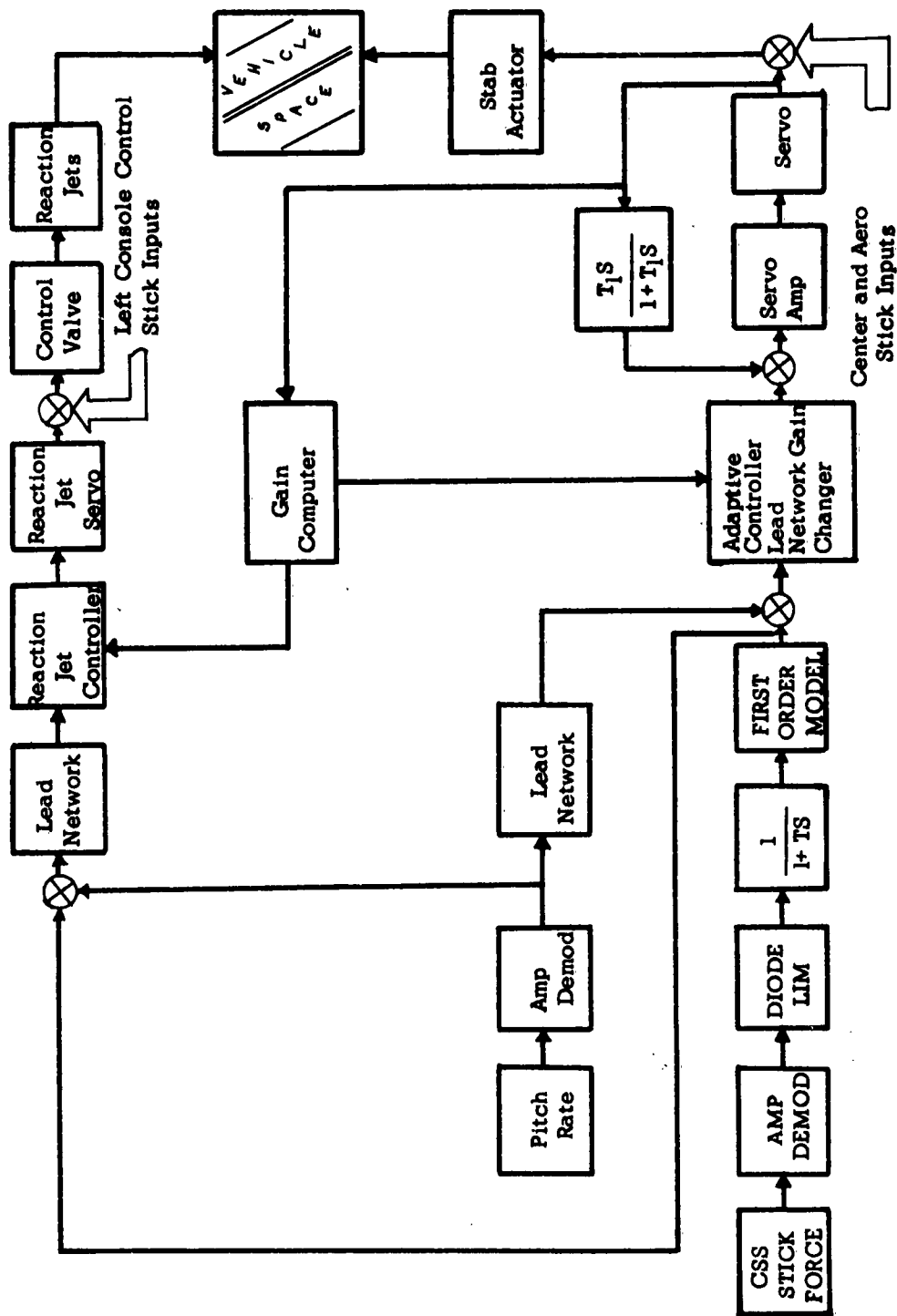

Fig. 8 Pitch axis block diagram

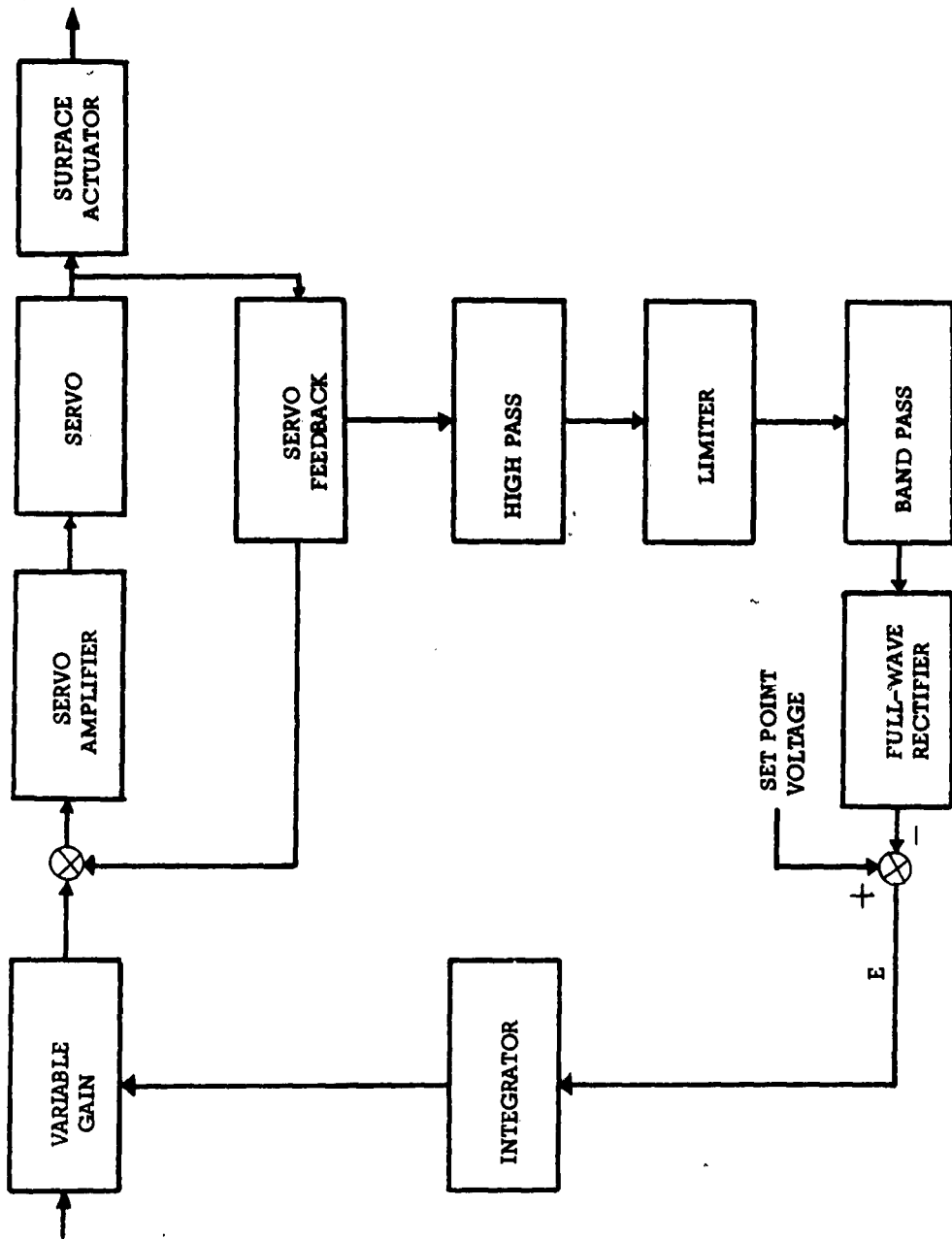

Fig. 9 Gain computer loop

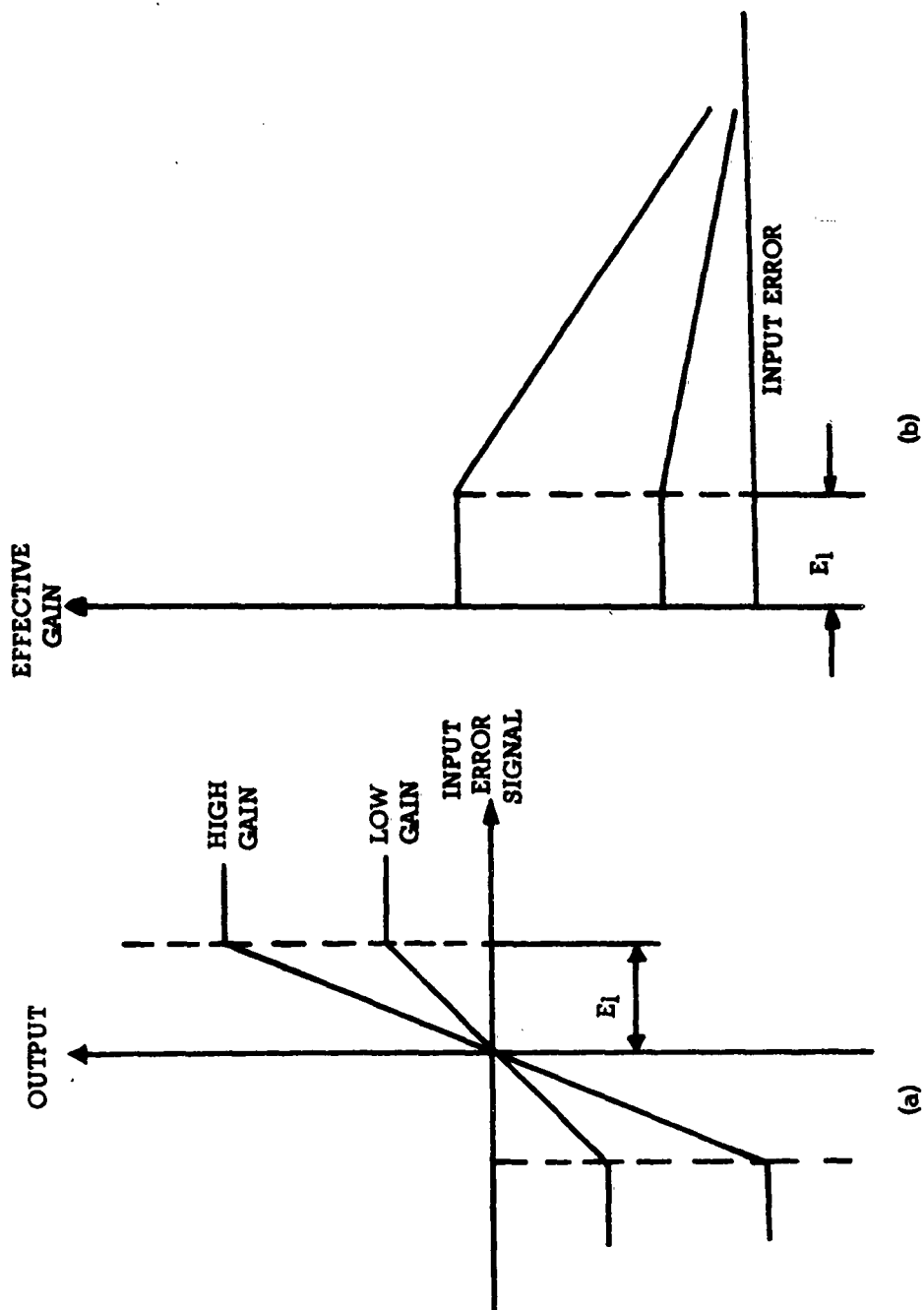

Fig. 10 Variable gain amplifier characteristic

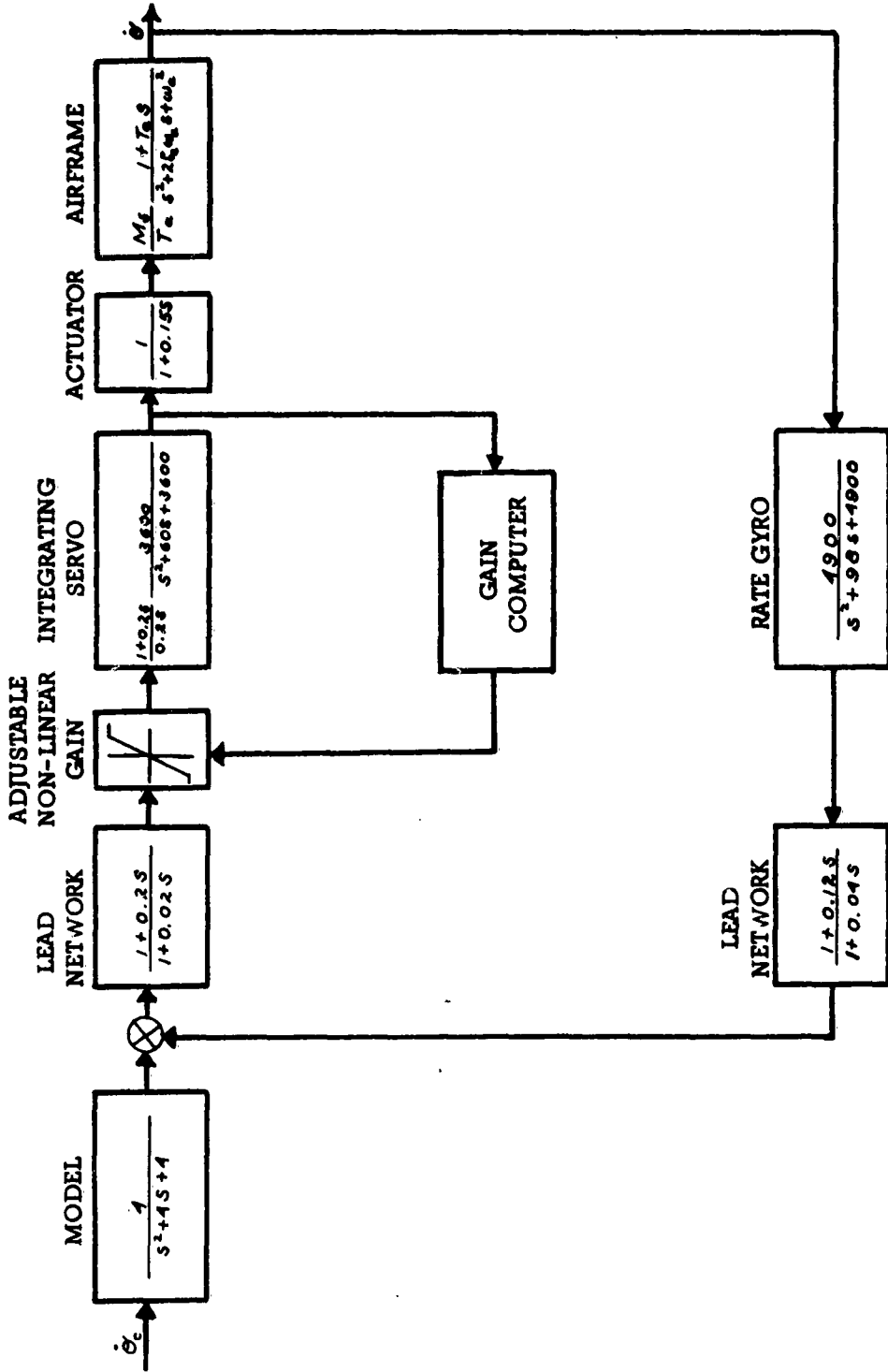

Fig. 11 Pitch rate adaptive loop

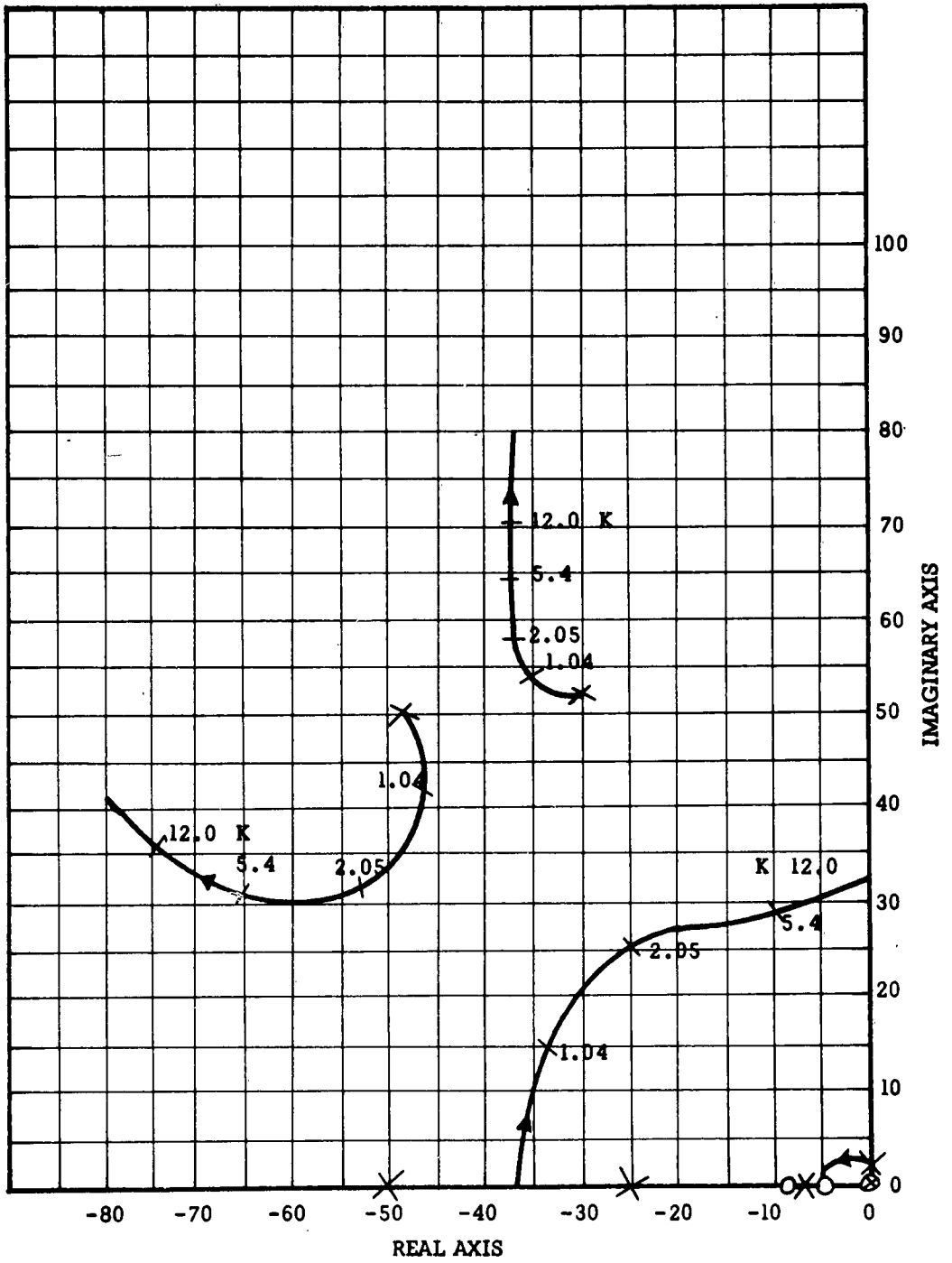

Fig.12 Root loci for Case 1

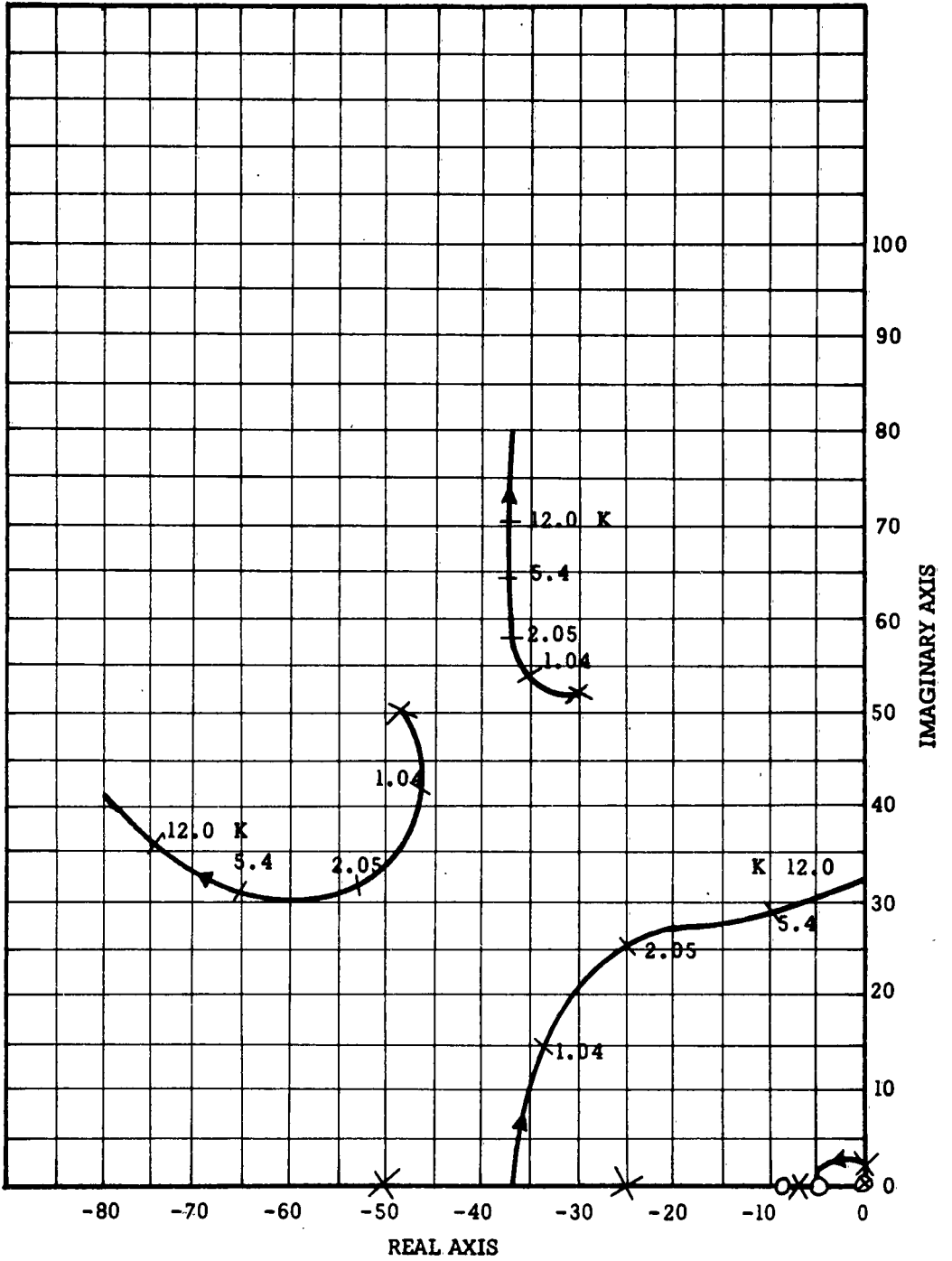

Fig.12 Root loci for Case 1

## DISTRIBUTION

Copies of AGARD publications may be obtained in the various countries at the addresses given below.

On peut se procurer des exemplaires des publications de l'AGARD aux adresses suivantes.

BELGIUM BELGIQUE	Centre National d'Etudes et de Recherches Aéronautiques 11, rue d'Egmont, Bruxelles
CANADA	Director of Scientific Information Service Defense Research Board Department of National Defense 'A' Building, Ottawa, Ontario
DENMARK DANEMARK	Military Research Board Defense Staff Kastellet, Copenhagen Ø
FRANCE	O.N.E.R.A. (Direction) 25, Avenue de la Division Leclerc Châtillon-sous-Bagneux (Seine)
GERMANY ALLEMAGNE	Wissenschaftliche Gesellschaft für Luftfahrt Zentralstelle der Luftfahrtokumentation München 64, Flughafen Attn: Dr. H.J. Rautenberg
GREECE GRECE	Greek National Defense General Staff B. MEO Athens
ICELAND ISLANDE	Director of Aviation c/o Flugrad Reykjavik
ITALY ITALIE	Ufficio del Generale Ispettore del Genio Aeronautico Ministero Difesa Aeronautica Roma
LUXEMBURG LUXEMBOURG	Obtainable through Belgium
NETHERLANDS PAYS BAS	Netherlands Delegation to AGARD Michiel de Ruyterweg 10 Delft

NORWAY  
NORVEGE  
Mr. O. Blichner  
Norwegian Defence Research Establishment  
Kjeller per Lilleström

PORTUGAL  
Col. J.A. de Almeida Viama  
(Delegado Nacional do 'AGARD')  
Direcção do Serviço de Material da F.A.  
Rua da Escola Politecnica, 42  
Lisboa

TURKEY  
TURQUIE  
Ministry of National Defence  
Ankara  
Attn. AGARD National Delegate

UNITED KINGDOM  
ROYAUME UNI  
Ministry of Aviation  
T.I.L., Room 009A  
First Avenue House  
High Holborn  
London W.C.1

UNITED STATES  
ETATS UNIS  
National Aeronautics and Space Administration  
(NASA)  
1520 H Street, N.W.  
Washington 25, D.C.



<p>AGARD Report 406 North Atlantic Treaty Organization, Advisory Group for Aeronautical Research and Development <b>THE CASE FOR ADAPTIVE CONTROLS</b> M. A. Ostgaard, E. B. Stear and P. C. Gregory 1962 25 pages, incl. 22 refs., 12 figs.</p> <p>This paper attempts to show that adaptive control systems are practical, that they have lived up to expectations, and that they represent a significant advance over the conventional linear control systems. To do this the original problems which led to the initiation of applied research effort on adaptive flight control systems and the expected solutions from this research are reviewed along</p> <p>P. T. O.</p>	<p>629.13.014.5 681.3</p>	<p>AGARD Report 406 North Atlantic Treaty Organization, Advisory Group for Aeronautical Research and Development <b>THE CASE FOR ADAPTIVE CONTROLS</b> M. A. Ostgaard, E. B. Stear and P. C. Gregory 1962 25 pages, incl. 22 refs., 12 figs.</p> <p>This paper attempts to show that adaptive control systems are practical, that they have lived up to expectations, and that they represent a significant advance over the conventional linear control systems. To do this the original problems which led to the initiation of applied research effort on adaptive flight control systems and the expected solutions from this research are reviewed along</p> <p>P. T. O.</p>	<p>629.13.014.5 681.3</p>
<p>AGARD Report 406 North Atlantic Treaty Organization, Advisory Group for Aeronautical Research and Development <b>THE CASE FOR ADAPTIVE CONTROLS</b> M. A. Ostgaard, E. B. Stear and P. C. Gregory 1962 25 pages, incl. 22 refs., 12 figs.</p> <p>This paper attempts to show that adaptive control systems are practical, that they have lived up to expectations, and that they represent a significant advance over the conventional linear control systems. To do this the original problems which led to the initiation of applied research effort on adaptive flight control systems and the expected solutions from this research are reviewed along</p> <p>P. T. O.</p>	<p>629.13.014.5 681.3</p>	<p>AGARD Report 406 North Atlantic Treaty Organization, Advisory Group for Aeronautical Research and Development <b>THE CASE FOR ADAPTIVE CONTROLS</b> M. A. Ostgaard, E. B. Stear and P. C. Gregory 1962 25 pages, incl. 22 refs., 12 figs.</p> <p>This paper attempts to show that adaptive control systems are practical, that they have lived up to expectations, and that they represent a significant advance over the conventional linear control systems. To do this the original problems which led to the initiation of applied research effort on adaptive flight control systems and the expected solutions from this research are reviewed along</p> <p>P. T. O.</p>	<p>629.13.014.5 681.3</p>

with certain pertinent historical aspects of linear feedback control theory. A typical flight control problem for re-entry vehicles is described, the conventional linear and the adaptive solutions to this problem are discussed in detail, and a practical mechanization of an adaptive flight control system for this application is described in some detail. Also some other promising adaptive techniques and their expected potential are discussed.

Finally, some closing arguments are given to complete the 'Case for Adaptive Control'.

This Report was presented at the Twenty-First Meeting of the Flight Mechanics Panel of AGARD, held in Paris, 6-10 July 1962.

with certain pertinent historical aspects of linear feedback control theory. A typical flight control problem for re-entry vehicles is described, the conventional linear and the adaptive solutions to this problem are discussed in detail, and a practical mechanization of an adaptive flight control system for this application is described in some detail. Also some other promising adaptive techniques and their expected potential are discussed.

Finally, some closing arguments are given to complete the 'Case for Adaptive Control'.

This Report was presented at the Twenty-First Meeting of the Flight Mechanics Panel of AGARD, held in Paris, 6-10 July 1962.

with certain pertinent historical aspects of linear feedback control theory. A typical flight control problem for re-entry vehicles is described, the conventional linear and the adaptive solutions to this problem are discussed in detail, and a practical mechanization of an adaptive flight control system for this application is described in some detail. Also some other promising adaptive techniques and their expected potential are discussed.

Finally, some closing arguments are given to complete the 'Case for Adaptive Control'.

This Report was presented at the Twenty-First Meeting of the Flight Mechanics Panel of AGARD, held in Paris, 6-10 July 1962.

with certain pertinent historical aspects of linear feedback control theory. A typical flight control problem for re-entry vehicles is described, the conventional linear and the adaptive solutions to this problem are discussed in detail, and a practical mechanization of an adaptive flight control system for this application is described in some detail. Also some other promising adaptive techniques and their expected potential are discussed.

Finally, some closing arguments are given to complete the 'Case for Adaptive Control'.

This Report was presented at the Twenty-First Meeting of the Flight Mechanics Panel of AGARD, held in Paris, 6-10 July 1962.