

UNCLASSIFIED

AD 412431

DEFENSE DOCUMENTATION CENTER

FOR

SCIENTIFIC AND TECHNICAL INFORMATION

CAMERON STATION, ALEXANDRIA, VIRGINIA



UNCLASSIFIED

## **DISCLAIMER NOTICE**

**THIS DOCUMENT IS BEST QUALITY  
PRACTICABLE. THE COPY FURNISHED  
TO DTIC CONTAINED A SIGNIFICANT  
NUMBER OF PAGES WHICH DO NOT  
REPRODUCE LEGIBLY.**

NOTICE: When government or other drawings, specifications or other data are used for any purpose other than in connection with a definitely related government procurement operation, the U. S. Government thereby incurs no responsibility, nor ANY obligation whatsoever; and the fact that the Government may have formulated, furnished, or in any way supplied the said drawings, specifications, or other data is not to be regarded by implication or otherwise as in any manner licensing the holder or any other person or corporation, or conveying any rights or permission to manufacture, use or sell any patented invention that may in any way be related thereto.

63-4-4



412431

CATALOGED BY DDC  
AS AD No.

DETERMINATION OF PARAMETERS FOR  
RADIOLOGICAL PREDICTION AND  
MONITORING SYSTEMS

Prepared for:  
Office of Civil Defense  
Department of Defense  
Washington, D. C.

412431

Radio Corporation of America  
Data Systems Center  
Bethesda, Maryland  
June, 1963

DDC  
RECEIVED  
AUG 1 1963  
RESOLVED  
TISIA R

DETERMINATION OF PARAMETERS FOR  
RADIOLOGICAL PREDICTION AND MONITORING SYSTEMS

Prepared for:

OFFICE OF CIVIL DEFENSE  
DEPARTMENT OF DEFENSE  
Washington, D. C.

CONTRACT NO. OCD-OS-62-140

This report has been reviewed in the Office of Civil Defense and approved for publication. Approval does not signify that the contents necessarily reflect the views and policies of the Office of Civil Defense.

QUALIFIED REQUESTORS MAY OBTAIN COPIES  
OF THIS REPORT FROM DDC

By: P. Reimers  
C. Diehm  
B. Holz  
H. Kurkjian  
D. Hatheway

Approved:

*D. Beaumariage*  
D. Beaumariage, Manager  
Data Systems Center

RADIO CORPORATION OF AMERICA  
DATA SYSTEMS CENTER  
BETHESDA, MARYLAND

JUNE, 1963

#### ABSTRACT

Design concepts and parameters are presented for two radiological monitoring systems; a Shelter-Based System, and an Automatic System. Gamma radiation intensities up to 1000 R/hr. are to be monitored. Recommended spacing of sensors is based on computer simulation of accuracies obtainable with various sensor spacings. Various combinations of instrument error, fallout pattern, probability of instrument malfunction, and orientations of the sensor network were used in these simulations. Initial costs and annual operating costs are estimated.

## TABLE OF CONTENTS

	Page
<b>SECTION I. INTRODUCTION</b>	<b>1-1</b>
1.0 SCOPE OF RESEARCH	1-2
2.0 ORIENTATION	1-3
3.0 SUMMARY AND CONCLUSIONS	1-3
4.0 METHOD OF DETERMINING SYSTEM PARAMETERS	1-9
4.1 Value of Radiological Data to National Level	1-9
4.1.1 Attack Phasing	1-9
4.1.2 Requirements for Information Accuracy	1-10
4.1.3 Required Decisions and Actions	1-11
4.1.4 Command and Control	1-12
4.1.5 System Vulnerability	1-12
4.2 Approach	1-12
5.0 STRUCTURE OF REPORT	1-16
<b>SECTION II. CHOICE OF CONCEPTS</b>	<b>2-1</b>
1.0 DATA NEEDS	2-2
1.1 Decisions Which Might be Made at Regional Center	2-4
1.1.1 To Warn Other States if Fallout Appears in a Given State	2-4
1.1.2 To Request a Decontaminated Route Passing Through Several States	2-5
1.1.3 To Advise Movement of Persons from One State to Another State	2-7
1.1.4 To Advise the National Center that Help can be Given to Other Regions	2-7
1.1.5 To Advise the National Center that Help is Needed	2-7
1.1.6 To Perform the Functions of a Regional Center	2-8
1.1.7 To Warn States of Expected Arrival of Fallout	2-8
1.2 Decisions Which Might be Made at the National Center	2-9
1.2.1 To Warn Other Regions if Fallout Appears in One Region	2-9
1.2.2 To Order One Region to Assist Another Region	2-9
1.2.3 To Supply Information Required for Planning Offensive and Defensive Strategy	2-9
1.2.4 To Warn a Region of Expected Arrival of Fallout	2-9

	<b>Page</b>
1.3 Decisions at State, County, and Local Levels	2-9
1.3.1 Decisions at State Level	2-10
1.3.2 Decisions at County Level	2-10
1.3.3 Decisions at Local Level	2-11
2.0 SYSTEM EVALUATION CRITERIA	2-14
2.1 Definitions of Criteria	2-14
2.1.1 Effectiveness	2-14
2.1.2 Cost	2-14
2.1.3 Speed of Response	2-14
2.1.4 Reliability	2-15
2.1.5 Invulnerability	2-15
2.1.6 Implementation Feasibility	2-15
2.1.7 Flexibility	2-16
3.0 SYSTEMS GIVEN PRELIMINARY CONSIDERATION	2-17
References	2-24
<b>SECTION III. ELEMENT CONSIDERATIONS</b>	<b>3-1</b>
1.0 SENSORS	3-1
1.1 Sensor for Shelter-Based System	3-3
1.2 Sensor for Automatic System	3-3
2.0 SENSOR TO RELAY POINT COMMUNICATION	3-4
2.1 Shelter-Based System	3-4
2.2 Automatic System	3-5
2.2.1 Sensor Transmitter-Receiver	3-5
2.2.1.1 Sensor Receiver	3-5
2.2.1.2 Sensor Transmitter	3-6
3.0 RELAY POINT EQUIPMENT	3-6
3.1 Shelter-Based System	3-7
3.1.1 Relay Equipment	3-7
3.1.2 Relay to Weather Observation Station Communications	3-9
3.2 Automatic System	3-10
3.2.1 Automatic Meteorological Observing System	3-10
3.2.2 Relay Point Receiver and Transmitter	3-13
3.2.2.1 Receiver	3-13
3.2.2.2 The Transmitter	3-14
4.0 COMMUNICATIONS	3-14
4.1 The FAA Service A Network	3-16
4.2 Interchange Centers	3-18
4.3 Message Formats	3-18
4.4 System Operations	3-19
4.4.1 Present Weather Observation System	3-19
4.4.2 Radiation Monitoring System	3-20
4.5 Cost Estimates	3-20
5.0 DATA PROCESSING	3-21
5.1 National Level	3-21
5.2 Regional Level	3-22

	Page
6.0 IMPLEMENTATION FEASIBILITY	5-3
7.0 FLEXIBILITY	5-4
8.0 LIMITATIONS OF SYSTEMS	5-5
Reference	5-6
SECTION VI. CONCLUSIONS AND RECOMMENDATIONS	6-1
1.0 CONCLUSIONS	6-1
2.0 RECOMMENDATIONS	6-2
2.1 Implementation of a Shelter-Based System	6-2
2.2 Pilot System	6-3
2.3 Small Scale Effects	6-4
2.4 Fallout Prediction Improved by Monitoring	6-4
References	6-7
APPENDIX A. SPECIFICATIONS FOR RELAY POINT PANEL	A-1
1.0 SCOPE	A-1
2.0 PERFORMANCE REQUIREMENTS	A-1
3.0 TEMPERATURE REQUIREMENT	A-2
4.0 COMPONENTS	A-2
5.0 POWER SUPPLY	A-2
6.0 INTERNAL CONSTRUCTION	A-3
7.0 PHYSICAL CHARACTERISTICS	A-3
8.0 IDENTIFICATION	A-4
APPENDIX B. ANALYSIS OF COMMUNICATIONS DELAYS	B-1
APPENDIX C. SMALL SCALE EFFECTS	C-1
1.0 PURPOSE	C-1
1.1 Basic Structure of the Gamma Radiation Field	C-1
1.2 The Influence of Small Scale Effects on the Basic Gamma Radiation Field	C-11
1.3 Predictable and Random Small Scale Effects	C-17
1.4 The Direct and Scattered Gamma Flux Components of the Basic Gamma Radiation Field	C-19
1.5 Statistical Analysis of Small Scale Effects	C-22
References	C-24

LIST OF ILLUSTRATIONS

Figure	Title	Page
I-1	Radiological Monitoring System Parameters	1-7
II-1	Radiological Monitoring Concepts	2-22
II-2	Standard Metropolitan Statistical Areas	2-23
III-1	Shelter-Based System, Block Diagram	3-8
III-2	Automatic System, Block Diagram	3-10
III-3	Service A System Map	3-17
III-4	Zone Boundaries	3-24

## LIST OF TABLES

Table	Title	Page
IV-1	Error Frequency versus Spacing	4-21
IV-2	Confidence Factor versus Detector Spacing	4-24
IV-3	Summary of Communications Delays	4-46
IV-4	Initial Cost, Automatic System	4-76
IV-5	Annual Cost, Automatic System	4-80
IV-6	Initial Cost, Shelter-Based System	4-81
IV-7	Recurring Cost, Shelter-Based System	4-81
C-1	Percent Contribution versus Distance	C-5
C-2	Small Scale Effects Frequency Distribution	C-23

SECTION I  
INTRODUCTION

This report describes the results of the research performed under Contract OCD-OS-62-140 awarded by the Office of Civil Defense of the Department of Defense on April 30, 1962, to the Data Systems Center of the Radio Corporation of America.

The importance of civilian defense is recognized by the present structure of the Civil Defense organization and by the existence of a national shelter program. Both the approved shelter program and that planned for the future are "active" elements of the civil defense program. National military plans contain both offensive and defensive elements. Among defensive elements is civilian defense, for the ability of a nation to protect its civilian structure is, in itself, a form of deterrence. A defensive element may include both active and passive components.

Passive components are those which react to the environment, sensing and displaying changes in it so that active components may be brought to bear. It became clear in the course of the work that a radiological reporting system was valuable in proportion to the existence of active elements such as shelters in being or plans for moving populations. By the same token, active elements could be effective in proportion to support furnished by passive elements. Briefly then, a shelter program requires a radiological reporting structure to be effective, and a radiological reporting structure requires a shelter program to be valuable.

These broader considerations were recognized as outside the scope of the current research. They have been noted because the research team operated within this general conceptual framework.

#### 1.0 SCOPE OF RESEARCH

The purpose of this research was to develop parameters for local and national prediction and monitoring systems. Prediction and monitoring systems of the national, regional, and state levels were examined to develop improved collecting, handling, and displaying systems. Consideration was given to improved instruments and related equipment, including automatic reporting systems, as to their role and adequacy for the task. Various automatic reporting systems were examined for statistical reliability; for technical and economic feasibility; and for comparable performance as between different systems.

Particular emphasis was given to the evaluation, elimination and control of variables such as terrain effects, influence of weather, shielding of nearby buildings and vegetation, detector spacing and directionality.

In general, parameters for national and local prediction and point monitoring systems, for data handling and display techniques, for improved hardware, and organizational and training requirements were developed. The work began with analysis of needs for radiological data and consideration of various possible ways of obtaining it, and built on research already done in this area. This analysis is presented in more detail in Section II.

## 2.0 ORIENTATION

Emphasis has been on fixed point monitoring systems, including automatic reporting systems.

Meeting the radiological data needs at national and regional levels was of primary concern, without ignoring state and local levels. That is, the needs to be met are the needs of authorities who would be planning the best utilization of the nation's resources, at national level, as well as those of officials at regional level who would be backing up national authorities, and advising state and local officials of the radiological situation for operational decision-making.

## 3.0 SUMMARY AND CONCLUSIONS

It is concluded that a fixed station monitoring system can obtain reasonably accurate information about large scale effects. In doing this the station obtains information about actual intensities (large and small scale effects) in the immediate neighborhood of isolated points at which sensors are located. The usefulness of this information is limited to deriving information about large scale effects over the whole area, and representing the actual intensity (large and small scale effects) within several tens of feet of those isolated points. A fixed station monitoring system with sensors spaced the order of a mile apart (or more) does not provide information which may be used operationally to represent the actual intensities (large and small scale effects) over an area. (A spacing of the order of hundreds of feet would be required for this purpose.)

Large gains in accuracy of knowledge of large scale effects are obtained from any given decrease in sensor spacing, to a spacing of about twenty miles. Significant gains result from further decreases to about ten miles and smaller gains to about six miles. Further decreases yield only small gains in accuracy because this knowledge is limited by large gradients in large scale effects (in a small percentage of the area), and also by small scale effects, sensor inaccuracies, and other influences. Sensor spacings of one or two or three miles do yield slightly better information than spacings of six miles, but this small improvement in information comes at a disproportionate price.

Studies of information needs indicated that information about large scale effects is needed at all organizational levels. Knowledge of actual intensities (large and small scale effects) is important at local level. Knowledge of actual intensities would be useful even at National Level if it could be provided economically. In fact, implementation of any monitoring system which has been proposed is not expected to eliminate the need for interrogations from National Level for detailed information about specific points and areas.

It follows that limits on the accuracy of information which could be useful (even at National Level) were found to exceed the accuracies obtainable with feasible fixed station monitoring systems.

Therefore, sensor spacing, and system accuracy requirements, should be based on the relationship of cost and effectiveness rather than on limits on information needs. This was done, as described in section IV,7.

It was concluded then, that a radiological monitoring and prediction system is needed for regional and national use during the early post attack period. Two systems (a preferred system and an alternate) which will best meet this need are summarized below, and are presented in detail in other sections. Further, a hybrid system, or combination of these, is considered.

It was further concluded that local operational data needs would best be met by communicating with shelters by shelter transceiver or telephone, and by mobile monitoring.

The two systems described differ in their data collection methods (items 1 through 7 of figure I-1), but are similar with respect to higher level communications, data processing, and display (items 8 through 10). In a sense they may be considered a single system with two variations. One is referred to as the Shelter-Based System and the other as the Automatic System. Although either system would be suitable, the Shelter-Based System is considered better for reasons of flexibility, implementation feasibility, and maintainability, as described in section V-1.

In the Shelter-Based System, a person in each of certain designated shelters would take a gamma radiation intensity reading each hour and communicate this reading to the relay point (also a shelter) by shelter transceiver or telephone. This procedure is compatible with present monitoring plans. At the Relay Point, readings received from six other points and the reading at the Relay Point itself would be manually recorded by setting switches. This process is planned to be completed a few minutes before the scheduled time for interrogation of this relay point. At the scheduled time the seven readings at this relay point are scanned

and automatically transmitted to regional headquarters and to the National Center by a communications network.

In the Automatic System, unattended sensors record intensities which are transmitted to the Relay Point. The Relay Point in this case is recommended to consist of an AMOS (Automatic Meteorological Observing System) Unit. From this point, intensities are transmitted to regional headquarters by a communications network. Some comparisons of the parameters of these systems are given in figure I-1.

	Shelter-Based	Automatic
1. Sensor	Ion Chamber (CD V-711BX)	Ion Chamber (Modified CD V-711BX)
2. Number of Sensors	20,000	20,000
3. Spacing of Sensors	6 to 20 miles, varying with pop- ulation density; hexagonal arrange- ment approximately.	6 to 20 miles, varying with pop- ulation density; hexagonal arrange- ment approximately.
4. Reporting interval	1 hour	1 hour
5. Sensor to Relay Point Communication	Shelter Transceiver or Telephone	Radio or land line
6. Number of Relay Points	3,000	1,000
7. Characteristics of Relay Point Equipment	Special design, manually operated	Automatic Meteor- ological Observing System Station
8. Relay Point to Reg- ional and National Headquarters Commu- nication	Weather land line network (FAA Ser- vice A, supplemented)	Weather land line network (FAA Ser- vice A, supplemented)
9. Computing equipment Regional Headquarters	Medium Size Scientific Computer	Medium Size Scientific Computer
10. Display Equipment at Regional Headquarters	X-Y Plotter; Re- production and Projection Equipment	X-Y Plotter; Reproduction and Projection Equipment
11. Equipment at National Center	As now planned	As now planned
12. Initial Cost*	13.1 million	28.3 million
13. Annual Operating Cost	5.5 million	2.6 million

Figure I-1. Radiological Monitoring System Parameters

\* Includes all costs except for Shelter-Based System Sensor to Relay Point communication. See pages 4-60 to 4-64 for detailed breakdown.

In either the Shelter-Based System or the Automatic System, data are transmitted from relay points to Regional and National Centers by a fixed communications network. In order to reduce the complexity at outlying points, a polling type of net operation is recommended. Information, available at each of the relay points, is transmitted upon command of the network. The weather communications network (FAA Service A) operates in this way and is recommended for possible use.

Gamma radiation intensities are transmitted to the eight Regional Headquarters and to the National Center. Computer processing occurs at each of these places. Intensity contours, population exposure estimates, predicted intensities, and predicted exposures, are derived. Monitored intensities, weather data, and burst information are used in these calculations.

#### 4.0 METHOD OF DETERMINING SYSTEM PARAMETERS

Determining the parameters of a radiological reporting system consists both of isolating the important elements and criteria and of evaluating them by themselves and in combination. Criteria could not be applied without some knowledge of the value of radiological data to higher levels of Civil Defense control. Considerations were determined as far as possible at the outset of the study and were further developed as the control of the study allowed. They are expressed in terms of value to the national level, although they apply to regions as well.

#### 4.1 Usefulness of Radiological Data to National Level

The usefulness of radiological data from a sensor network to the National Center depends on the following factors:

1. attack phasing
2. requirements for information accuracy
3. required decisions and actions
4. command and control
5. system vulnerability

4.1.1 Attack Phasing.-The radiological monitoring system requirements depend critically on the question of attack phasing and its relationship with the other factors listed above. At one extreme would be an essentially simultaneous salvo attack. In this case, it is assumed by some persons that for the period immediately following the attack civil defense would be directed by lower level headquarters. This situation would continue throughout the period of most of the fallout deposition and up to the point where it is safe for a substantial number of the surviving population

to emerge from shelters. During this period it has been claimed that the information requirements for the national center can be met by the current National Resources Evaluation Center programs. These programs, based currently on information from the Bomb Alarm system, estimate casualties, and damage to a large number of resources. Fallout contours are also computed.

This procedure provides a picture which may be adequate for an early over-all qualitative estimate of the situation. However, it does not provide a basis for estimating the situation with respect to critical resources located at a relatively small number of points nor does it provide a basis for initiating emergency actions such as decontamination, movements of people, materiel, or supplies, manning of vital facilities, etc. It can be argued that (1) no actions of this kind would be undertaken immediately following the attack and (2) when the time comes for such actions, communications with local areas will establish feasibility in terms of nuclear radiation hazard.

The validity of these arguments decreases with an increase in the period during which the strategic nuclear exchange is assumed to take place. If this period stretches out into days and weeks it is clearly not acceptable to dispense with national direction of civil defense activities until after fallout deposition has been completed. For this situation it is necessary to evaluate the need for radiological data for a list of required actions and decisions considerably expanded from that of the single salvo attack.

4.1.2 Requirements for Information Accuracy.-The need for radiological data from sensors can be related to requirements for information concerning radiation intensities to an accuracy greater than that obtainable only from estimates of burst locations

and yields coupled with meteorological data.

Errors in estimates of ground zero locations and of wind vectors are unimportant when information is wanted concerning a situation that is not sensitive to variations in position, orientation, and shape of isointensity contours. For example, estimate of the total area affected by intensities of a given level is relatively insensitive to these variations. Obviously, the situation at specific locations is sensitive to these variations. When, for example, an estimate of the situation is being made at the national center, the importance of errors in the position, orientation, and shape of isointensity contours depends on the uniformity of distribution of resources that are being considered.

If there are errors in estimates of number or yield of bursts, even the estimates of total areas affected by radiation intensities of a given level can be seriously in error. Radiological sensor data would provide clues to improve even these overall estimates.

4.1.3 Required Decisions and Actions.--A list of the decisions that may be required at the national center is given in section B.1.

Consider the following questions that may be typical of the information needed for an estimate of the situation:

(1) How many ports or petroleum refineries, for example, will have radiation intensities at levels safe for manning within the next x hours?

(2) Which airfields of a certain type can be expected to be put out of operation because of radiation and for how long?

These questions are sensitive to errors in location of fallout contours. Furthermore, if fallout deposition is still taking place, they require more information than would be available to people on the scene even if they are equipped with sensors.

4.1.4 Command and Control.—It is essential that leadership and authority at the national level be exercised at the earliest possible time following the initiation of a nuclear attack. The accuracy and timeliness of the information available at the national level will have an important effect on the ability to establish the central authority following a devastating attack. Predicting time of arrival of fallout, for example, should be a responsibility of national and/or regional civil defense centers. Warnings should proceed from higher to lower levels. In the post-attack period, the existence of such information may be more important to the re-establishment of control than is the existence of law. Once this flow of information and cooperation has been established it should be easy to establish in the opposite direction.

4.1.5 System Vulnerability.—Since all information systems are vulnerable to damage from attack and possibly also to sabotage or spoofing, there is added advantage for multiple data sources and communication channels, as well as multiple types of information (e.g. monitored radiation intensities as well as burst data).

#### 4.2 Approach

The method used in the study was an adaptation of that which has been successfully applied to military information systems.

Design of information systems is always so complex that each problem requires that a unique method be, at least in part, developed for it. Because of the unicity of the civilian defense problem, the approach which had been useful in military information systems had to be revised quite drastically.

The broad conceptual model for civilian defense against radiation in the post-attack period is that of an information system which serves a decision making complex. To knowledge of physical and physiological effects is added knowledge of current radiation in space and time. The bank of knowledge modified by current information allows decisions to be made on actions to limit the deleterious effects of radiation and to protect the population in the area under control

The radiation reporting system is seen always as embedded in the larger Civil Defense structure. This larger structure is concerned with many other kinds of information being reported and must make decisions from a large number of alternatives and over a wide range of activities.

The research began with investigation of system requirements. Requirements were expressed as needs for radiological data at various levels of civil defense. Planning and decision-making which would be critically influenced by radiological information were examined. From these findings, estimates were made of the accuracy required to make specified decisions. Section II.1.0 shows the results of these considerations expressed in terms of accuracies.

Had it been possible to find explicit statements of decisions which would be made under various conditions of radiation exposure,

it might have been possible to proceed from the needs for data to the accuracies required from a reporting system. These explicit statements have not been nor could they be made. Conditions vary so widely that the decisions under any set of circumstances are largely judgmental. At the local level, for example, the size of the civilian group, the age level, degree of prior exposure, and protection factor of shelters must be taken into account in deciding what activities should be undertaken.

The civil defense structure is more difficult to direct from higher echelons than is the military. First, the organization is less disciplined because it is civilian in nature. Political formations such as state governments intervene between echelons; the regional structure of civil defense, although technically necessary, has no political counterpart. Because of this disparity between the political and the technical structure, and because of the pervasive nature of civil defense in the post-attack period, it is difficult to determine which decisions are policy and which are operational control. Here again, it is difficult to find clear guidelines for decision explicitly expressed.

Because the difficulty of the decision process made policy formation equally difficult, the optimal method of going from data needs to required accuracy could not be followed. System accuracy, which was being developed simultaneously with requirements, has to be pursued independently. Available system elements such as sensors, communications, data processing and displays were studied by themselves and in system combination. Examination of the rate of change of gamma radiation intensity with distance in the large scale pattern and small scale variations made clear that the spacing of sensors was an important unknown parameter.

The relationship between sensor spacing and accuracy of information about actual intensity was not known. A computer simulation was undertaken to determine the effect of varying a number of parameters. Section IV-2 describes this simulation in detail and shows the interrelationships of indicated dose rate accuracy and such influences as instrument error, fallout pattern, probability of instrument malfunction, orientations of the sensor network, and small scale effects.

The range of detector spacings which would provide effective dose rate accuracy was used as input to further design stages.

Various devices which could sense, communicate, compute, or display data were considered from among those presently available or soon to become available. By considering requirements and limitations, these were narrowed to a few which could be considered for inclusion in system designs.

From the selected devices and from possible system configurations, two radiological reporting systems were designed. The advantages and disadvantages were studied and evaluation criteria applied.

## 5.0 STRUCTURE OF REPORT

The remainder of this report is divided into five sections:

CHOICE OF CONCEPTS  
ELEMENT CONSIDERATIONS  
SYSTEM CONSIDERATIONS  
SYSTEM EVALUATION  
RECOMMENDATIONS

In CHOICE OF CONCEPTS data needs and system evaluation criteria are discussed, and a preliminary selection is made of systems to be considered in detail.

In ELEMENT CONSIDERATIONS, the choices of types of sensors, relay units, communications and data processing methods, and data processing and display equipment are presented.

In SYSTEM CONSIDERATIONS, reasons for choices of sensor distribution and operational doctrine are presented, and training requirements, personnel requirements, and cost estimates are given.

In SYSTEM EVALUATION, methods of evaluation, and limitations of the recommended system are stated.

In RECOMMENDATIONS, the preferred approach in implementing the recommended system, beginning with a pilot system, is described. Also, other research which would contribute to future radiological monitoring and prediction techniques is suggested.

SECTION II  
CHOICE OF CONCEPTS

In order to express clearly parameters which define a reporting system, they must be shown as applying to specific systems. If this is not done, systems are expressed in such general terms that neither the systems nor the parameters can be judged.

The need for radiological data at the various echelons of the civil defense structure was developed. The complexity of the decision process presented a direct line to be followed between these data needs and a comparative evaluation of contending concepts. It is clear that unless the system meets at least some of these needs there is no justification for building it. We can apply a number of criteria to these concepts to choose those which are to be developed to the system design stage.

The most important of the design criteria to be applied is effectiveness. To some extent the ability to generate data to meet the needs of the various echelons is a measure of effectiveness. We have defined effectiveness to include consideration of accuracy so that it may be applied comparatively to system designs rather than as a limiting test.

## 1.0 DATA NEEDS

The interrelationships between active and passive elements of civil defense were discussed in section I. No attempt has been made to estimate to what extent plans and construction will have developed by the time the organization is called upon to function. Assuming some capability for action, data needs can be stated for various organizational levels of civil defense in terms of the kinds of decisions which would be made at these levels.

Widely different situations are expected in different areas of the country during the emergency period. Some decisions and actions which would not be germane to a densely populated, badly hit area, will apply to a less populated area which receives light fallout. Knowing the true situation will be important to decision makers in both cases. Defining this knowledge requires that accuracy be described as the relationship of what is reported by the system to what actually exists. This is more precisely defined by the considerations which follow.

It is appropriate to state one requirement for this system in terms of the probability of knowing, to a specified accuracy, the radiation intensity at any point and time. The design objective could be stated as the minimum cost system yielding specified values of  $\pi$ ,  $a$ , and  $b$ , such that for all points  $p$  and times  $t$  of interest and for the appropriate range of values of the radiation intensity  $W(p,t)$  the probability  $P$  is such that

$$P = \text{Prob} \left[ a \leq \frac{\hat{W}(p,t) - W(p,t)}{W(p,t)} \leq b \right] \geq \pi$$

where  $\hat{W}(p, t)$  is the estimate of the radiation intensity obtained by means of the system. It is seen that this leads to the use of  $a$  and  $b$  as indications of accuracy and of  $\pi$  as an indication of the confidence of the estimate.

The probability  $P$  is a function of the probability distribution of fallout patterns over the set of all possible attack, meteorological, and terrain conditions, as well as such system characteristics as sensor spacing, instrument accuracy, system reliability and survivability, and data processing procedures.

On the one hand, a statement of the required values of  $\pi$ ,  $a$ , and  $b$ , constitute a system requirement. On the other hand, given a radiological monitoring system, determination of the values of  $\pi$ ,  $a$ , and  $b$ , which correspond to the performance of that system constitutes a method for evaluating that system.

In order to determine suitable values of  $\pi$ ,  $a$ , and  $b$ , it is necessary to anticipate those decisions and actions which will be based on radiological information during an emergency period. Many of these decisions require information in addition to radiological data; for the present purpose only the needs for radiological information will be considered.

Decisions are expressed as those which inhere in the civilian defense function. It is recognized that the most important function of the national center may be to advise policy makers on survival so that strategic decisions can be made on the conduct of military operations. The pervasive influence of Civil Defense information has been mentioned. Because radiological information must meet the direct needs first, only these are presented. That it will meet other needs is recognized. Because emphasis is upon

defending the entire population, decisions which might be made at regional level are described first.

Notation to be used in the discussion is:

$W(p,t)$  = actual radiation intensity at point  $p$  and time  $t$ .

$M(p_i, t_j)$  = measured radiation intensity at point  $p_i$ ,  $i = 1, 2, \dots, n$  and time  $t_j$ ,  $j = 0, 1, \dots$  where  $t_0$  is the time of burst. The time intervals  $\Delta t = t_j - t_{j-1}$  are not necessarily uniform.

$\hat{W}(p,t)$  = estimate of  $W(p,t)$  based on  $M(p_i, t_j)$  and possibly other information such as burst point, yield, wind vectors.

## 1.1 Decisions Which Might Be Made at Regional Center

### 1.1.1 To Warn Other States if Fallout Appears in a Given State.

The requirement here is to determine with a specified degree of confidence that the radiation intensity over a given region does or does not exceed a certain threshold. In other words, we want to know, with probability of at least  $\lambda$  on the basis of measurements  $M(p_i, \tau)$  at time  $\tau$  and points  $p_i$ ,  $i = 1, 2, \dots, n$ , whether the maximum of  $W(p, \tau)$  over all  $p$  in the region is greater than (or less than or equal to)  $p$ . That is, if

$$\max_{p_i} M(p_i, \tau) = \rho$$

we want to know with confidence coefficient  $\lambda$  that

$$\max_p W(p, \tau) \leq \rho$$

or

$$P_F \left[ \max W(p, \gamma) < \beta \right] = \lambda$$

where  $P_F$  is the fiducial probability.

1.1.2 To Request a Decontaminated Route Passing Through Several States.- Presumably this decision would not be made until after deposition has been essentially completed from all known bursts affecting the area.

If there is only one burst, this determination can be made when successive monitored intensities indicate that radiation levels are decreasing with time. However, if there are multiple bursts contributing to the fallout over a given area, differences in the time of arrival may cause the pattern of intensities to vary over time in such a way that the determination cannot be made with assurance without information to supplement that obtained from the sensors. In particular, prior to drawing conclusions from successive monitored intensities, knowledge is needed that the time of arrival has passed for significant amounts of fallout from all prior bursts affecting the area. This knowledge may require more information than can be made available at regional level. If so, it may be necessary to settle for a procedure of (1) extending monitoring over adjacent areas, at least in the direction of prevailing winds, and (2) concluding that deposition is essentially completed over the area of interest when intensities decrease with time over the augmented area.

Such a procedure could lead to (1) serious errors in the event of unanticipated wind conditions, or (2) serious delays in undertaking a mission if the decision is postponed until intensities decrease in a region from which fallout in fact would not arrive.

The final decision to undertake a decontamination mission would be made only after estimating that the total expected dose that would be received by those performing the mission is within acceptable limits. Presumably mobile monitoring at local level(s) where the decontamination would be performed could provide data for this purpose. Since the accuracy requirements are relatively severe, it is desirable to supplement information obtained from fixed sensors.

Before requesting mobile monitoring, however, a headquarters must have some preliminary information indicating whether there is a reasonable probability of feasibility and enabling selection among possible routes of the one(s) that appear most likely. At a minimum, the headquarters must know whether radiation intensities along the route are within safe limits for mobile monitoring.

The specification for this application should be the probability of knowing, to a specified accuracy, the radiation intensity at any point along the route in question. In other words, for specified values of a and b we want to determine  $\pi$  so that

$$\text{Prob} \left[ a \leq \frac{\hat{W}(p, \tau) - W(p, \tau)}{W(p, \tau)} \leq b \right] \geq \pi$$

for time  $\tau$  and for points  $p$  along the route in question.

For the purpose of estimating the effect of sensor spacing on this information requirement, the distribution of the random variable

$$J(p_k, \tau) = \left[ \hat{W}(p_k, \tau) - W(p_k, \tau) \right] / W(p_k, \tau)$$

for a set of points  $P_k$ ,  $k=1, 2, \dots$  will be estimated. (It is seen that  $J(P_k, T)$  is a continuous functional version of the relative error.) In actual operations the points of interest would be along the route(s) being considered for decontamination. However, since the location of such points relative to the fallout pattern cannot be predicted, the analysis of system performance should be made for a set of points scattered over the entire region being simulated. In order to have a conservative estimate of system performance an effort should be made to include extreme values of  $J(P_k, T)$ . At the same time it is desirable to keep the computations reasonably simple. The analysis will also take account of possible procedures for estimating intensities at points other than those at which measurements are made.

1.1.3 To Advise Movement of Persons From One State to Another State.—Again, it is presumed that the decision would be made only after deposition has been essentially completed from all bursts known to affect the area.

It is necessary to consider the dose that would be received on the route(s) over which movement would take place as well as the intensity in the area into which population is to move. The first consideration is of the same form as that of 1.1.2 while the second is the same as that of 1.1.1. The acceptable limits on  $P$ ,  $\pi$ ,  $a$ , and  $b$ ; and the range of  $W(p, t)$  that is of interest may, however, be different.

1.1.4 To Advise the National Center That Help Can Be Given to Other Regions, and

1.1.5 To Advise the National Center That Help is Needed.—The radiological information requirements would vary depending on the

type of help offered or needed. However, the considerations are of the same form as those discussed under 1.1.1 and 1.1.2 and 1.1.7.

1.1.6 To Perform the Functions of a Regional Center That is Not in Operation as Authorized by the National Center.—This requirement affects the communications design but would not affect accuracy requirements beyond those considerations listed elsewhere in this section.

1.1.7 To Warn States of Expected Arrival of Fallout.—The problem here is to obtain an estimate  $\hat{W}(p, \tau + \Delta \tau)$  for points  $p$  of a region and time  $\tau + \Delta \tau$  on the basis of measurements  $M(p_i, \tau)$  at points  $p_i$  of the array at which fallout has arrived (therefore not necessarily scattered over the entire region) and at time  $\Delta \tau$  units earlier than the time for which the estimate is made.

The radiation intensity  $W(p, t)$  is a very complicated function of the attack pattern (e.g., number, spatial and temporal position and height of bursts), weapons' characteristics (e.g., yield, fission-fusion ratio), and terrain and meteorological conditions.

Ideally the estimate  $W(p, t)$  would be made with the use of a fallout model which is a mathematical realization of the above function with all available data, including monitored radiation intensities, used to estimate the parameters of the function. There are several reasons why, despite a number of efforts, a completely satisfactory fallout model has not yet been developed; namely: (1) many aspects of the fallout phenomenon are not well understood; (2) insufficient data exist to test some of the hypotheses concerning these phenomena; (3) a model that attempts to include all of the pertinent considerations in detail is

mathematically intractable. Aside from this, however, efforts to obtain an exact formulation of the function  $W(p,t)$  would not be justified for the kind of operational use considered here since it is not conceivable that very accurate information would be available concerning some of the parameters.

## 1.2 Decisions Which Might be Made at the National Center

The information requirements at the national center can be expressed in the same forms as those for regional center. In the following list of decisions reference is made to that part of 1.1 in which comparable considerations are discussed. The appropriate values of the parameters  $p$ ,  $\pi$ ,  $a$ , and  $b$ ; and the range of  $W(p,t)$  may be different for the national center.

1.2.1 To Warn Other Regions if Fallout Appears in One Region.— The considerations are comparable to those of paragraph 1.1.1.

1.2.2 To Order One Region to Assist Another Region.—The considerations are comparable to those of paragraphs 1.1.4 and 1.1.5.

1.2.3 To Supply Information Required for Planning Offensive and Defensive Strategy.— The considerations discussed in 1.1.1, 1.1.2, 1.1.7, and III.5.2.1.

1.2.4 To Warn a Region of Expected Arrival of Fallout.— The considerations are the same as those of paragraph 1.1.7.

## 1.3 Decisions at State, County, and Local Levels

Similar characterizations of radiological information needed for state, county, and local use may be made. Decisions which might be made at these levels are:

### 1.3.1 Decisions at State Level

- To request that rescue teams or supplies be sent from one county to another.
- To request decontamination of a route passing through more than one county.
- To advise movement of persons from one county to another.
- To advise regional headquarters that evacuees should be sent to other states.
- To advise regional headquarters that evacuees can be accepted from other states.
- To warn adjacent counties if radiation is detected in one county.
- To perform the functions of a county center which is not in operation.

1.3.2 Decisions at County Level.—There is variation from state to state in the number of reporting levels between local and state level. There may be two intermediate levels (sometimes called sector and area), or one (county), or none. However, the following decisions might be made at sector, area, or county level where these levels exist:

- To decide to move persons from a region under cognizance of one local center to that of another.
- To decide to request decontamination of a route passing through areas under more than one local center.
- To decide to request that assistance be sent from one local center to another.
- To advise the next higher level that evacuees can be accepted.
- To advise the next higher level that persons should be evacuated from this area to some other area.
- To perform the functions of a local center which is not in operation.

1.3.3 Decisions at Local Level.—Decisions which might be made at local level are:

- To undertake or not to undertake rescue and re-supply missions of various durations.
- To undertake or not to undertake decontamination missions.
- To perform mobile monitoring.
- To advise the public to take shelter (in the event of unpredicted fallout or failure to receive warning).
- To advise the public to remain sheltered, or to limit unsheltered stay times.
- To advise movement from one shelter to a safer one.
- To advise evacuation of a locality.
- To advise the next higher level that evacuees from other areas can be accepted.
- To advise the public that return to homes is permissible, possibly for limited periods.
- To advise individuals of the intensities to which they are being exposed so that each person's dose may be estimated.

Although it is of interest to examine values of  $\pi$ ,  $a$ , and  $b$  which appear to be appropriate for each decision, at each level, individually, only a single set of values at each level (the most stringent) determines the radiological information requirements at that level. Judgment necessarily enters at this point, for different planners and decision makers place different emphasis on importance of accurate radiological information. Values of these parameters have been chosen which are intended to satisfy most decision makers.

Recommended values of the parameters,  $P$ ,  $a$ , and  $b$  for Regional and National planning and decision making are  $P=.60$ ,

$a=1/2$ ,  $b=1$ . In other words it is recommended that a monitoring system provide these headquarters with intensity information which is within a factor of 2 of the true intensity 60% of the time. This choice of values was made after the computer simulation described in section IV-2 was completed. It is based on cost versus effectiveness considerations; more accuracy would be useful in making the decisions described if it were feasible to obtain that accuracy economically.

For local operational decisions, recommended values are  $P=.90$ ,  $a=1/4$ , and  $b=1/4$ . In this case, the true intensity would be within 25% of the indicated intensity 90% of the time. A fixed station monitoring system which will provide this accuracy is not considered economically feasible.

Systems described in this report are intended to meet the accuracy statement for Regional and National use. In most localities the local data requirements should be met by manual monitoring. State and County needs would be met by information passed up from local level, and down from Regional level.

A second requirement for the system is that it provide predictions of the future radiological situation. Accuracy of predictions depends not only upon radiological data accuracy, but also on weather information, burst information, sophistication of the prediction model and other factors. A precise statement of required prediction accuracy would not be meaningful, but accuracy comparable to accuracy of weather prediction might be obtained.

Improvements which the new system should achieve over present procedures are:

- a. More factual information on the radiological situation at all levels.
- b. More rapid and timely information.
- c. No major increase in over-all communications network requirements.
- d. More uniformly accurate radiation data.

## 2.0 SYSTEM EVALUATION CRITERIA

A new radiological reporting system, to be acceptable, must be better in meeting stated criteria than the existing or other proposed systems which could accomplish similar functions. Criteria considered are effectiveness, cost, speed of response, reliability, invulnerability, implementation feasibility, and flexibility. These criteria are not independent. For example, reliability, invulnerability and speed of response all contribute to effectiveness, as defined below.

### 2.1 Definitions of Criteria

2.1.1 Effectiveness.—Effectiveness is defined as the probability of knowing to a specified accuracy the radiation intensity at any point and time. The concept of effectiveness was described more precisely in section II.1.0.

2.1.2 Cost.—This is defined as including initial and stand-by costs. Initial costs include design and installation. Stand-by costs include maintenance, incremental communications, stand-by personnel, and rental or imputed depreciation on items not included in initial costs. Operating costs in the post-attack period, like those of any emergency system, will not be critical in deciding among systems; personnel requirements in number and depth of training will be more significant.

2.1.3 Speed of Response.—This is defined as the elapsed time over which radiological data will be sensed, transmitted, and processed, to affect a decision. It is made up of the response times of sensors, communications, and data processors to the extent that the functions must be performed in sequence.

2.1.4 Reliability.—This is defined as the degree to which the system will hold its specified performance when it is called upon. Reliability of hardware elements of the system, such as a sensor-transceiver, is measured by the probability that the element is in operable condition at any point in time. Reliability is estimated on the assumption that such elements will receive no maintenance during the critical period after attack. Routine maintenance would be performed during peacetime.

The dependability of human elements of the system also enters into the reliability of the system. Because radiation can be sensed only by means of instruments and because the data are transmitted by machines, the ability to read and to enter information is critical in this regard.

2.1.5 Invulnerability.—This is defined as the extent to which the system can be expected to withstand the effects of enemy action. Invulnerability can be increased through such measures as hardening of installations and the use of redundancy (1) to provide alternate system components for use in the event the original components are damaged and (2) to provide corroborating data to decrease the probability that the system can be successfully spoofed.

2.1.6 Implementation Feasibility.—This is defined as the extent to which the design can be installed within time and cost schedules. Systems which depend heavily upon development of new components would, for example, rank lower than those which will operate using state-of-art equipment. Where development is required, a system would be preferred in which new designs do not necessarily depend upon other designs in sequence.

2.1.7 Flexibility.—This is defined as the degree to which the system is insensitive to changes in design parameters, assumptions, and assigned functions. For example, the concept of flexibility would include the ability to accept without major system redesign addition of new types of sensors or increase in the number of sensor points or the substitution of high-speed for low-speed communication lines. The system should be able to add functions such as prediction in addition to monitoring current intensities.

While in stand-by status, the system should be able to function in an exercise mode maintaining logs required for critiques.

### 3.0 SYSTEMS GIVEN PRELIMINARY CONSIDERATION

The system concepts following were compiled in order to make a preliminary examination of systems covering a broad spectrum with respect to sensor density and degree of automation as well as a variety of doctrines for sensor distribution. Figure II-1 gives for each system estimated order of magnitude costs and ratings in terms of the criteria listed in section II-2.

Concept No. 1. Household instruments. With 53,000,000 households in the United States, the cost of putting an instrument in each household would be about 1 billion dollars at \$20 each. Assuming that a family shelter program were put into effect, such a system might prove effective for supplying the kind of detailed radiological picture needed at the local level, though there would be difficult problems of coordination. In order to satisfy the information needs of the regional and national levels, it would be necessary to provide means for collection and communication of data from a selected group of households. The reliability following an attack of a system based on the performance of specific individual households would probably be low. To provide extensive redundancy to increase reliability would probably significantly increase the cost of facilities for collection of data for transmission to higher levels and probably would also increase the response time. This concept received no further consideration.

Concept No. 2. Unattended sensors - dense network. A dense network for this purpose means spacing of less than 1 mile between sensors. At an optimistic cost of \$400 per sensor more than 1.5 billion dollars would be required for sensors.

In order to provide for communications and data processing more than 5 billion dollars would be required for the system. Such a system would have a high degree of effectiveness for regional and national needs. Spacing would probably have to be considerably under a mile in order to meet all local information needs. Even for a one mile spacing the cost is probably out of range of feasibility. This system received no further consideration.

Concept No. 3. Unattended sensors - sparse network. A sparse network is defined as meaning one with spacing of more than one mile between sensors. A sparse uniform network of 20,000 automatic sensors, spaced at 14 mile intervals, with communications, and computing equipment was originally estimated to cost about 30 million dollars. A unit cost of \$1000 was then assumed for sensors and an additional 10 million dollars was allowed for computers, communications, and displays. This system would have to be supplemented by mobile monitoring in order to meet local needs; however, it appeared to have sufficient promise for regional and national needs and to be within a cost range to warrant detailed consideration. It is designated as the Automatic System which is described in detail in this report.

Concept No. 4. Metropolitan sensors - dense. About 120 million persons living in urban areas could be served by an automatic system of unmanned sensors in these areas only. Figure II-2 shows the location of "Standard Metropolitan Statistical Areas."<sup>(1)</sup> Because of the reduced area, this system would require less than 15% of the number of sensors of Concept No. 2. However, rural areas would have only indirect information and data from non-urban areas that might be used for prediction would not be available.

Concept No. 5. Metropolitan sensors - sparse. This system would cost only about 15% as much as Concept No. 3. However, it would suffer the same drawbacks as Concept No. 4 with respect to rural areas and data for nationwide prediction. Furthermore, it would not meet local needs even in metropolitan areas.

Concept No. 6. Target area sensors. This concept is similar to No. 5 except that military installations would be included. It was estimated that this would increase the cost over that of No. 5 by about \$1 million. It suffers the same defects as No. 5 with respect to nationwide coverage. However, this system would permit improvement in the accuracy of information available to the National Resources Evaluation Center.

Concept No. 7. Shelter sensors - dense. The shelter program that was announced in May, 1962,<sup>(2)</sup> includes plans for shelter spaces for all Americans by 1967. Assuming that about 1,000,000 group shelters are established nationwide, and that a remote reading shelter instrument would cost about \$150, the cost of putting a sensor in each shelter would be about \$150,000,000. Provision would be made for communication of readings to regional headquarters and for computing equipment at regional headquarters as in Concept No. 8 below.

Concept No. 8. Shelter sensors - sparse. This system is similar in nationwide coverage to Concept No. 3. However, instruments read by persons in selected shelters would replace automatic units. The preliminary estimate of the cost of a system containing 20,000 sensors was \$20 million dollars. A computer and display would be required at the headquarters of each region. This system, designated the Shelter-Based System, is described in detail in this report.

Concept No. 9. Present system. The estimated cost for this system is based on 100,000 instruments at an average cost of \$60. The present system is considered to be only fair with respect to local needs because the present number of instruments is too small. (It is being increased, of course, as budgets permit.) It is considered poor with respect to regional needs because of the likely response time during an emergency and because of differences in quality of preparations for radiological monitoring from state to state and locality to locality.

Concept No. 10. Augmented present system. Increasing the number of sensors to 500,000 would enhance the effectiveness of the present system. Further, no better way to meet many of the local monitoring needs has appeared. However, it cannot be guaranteed that all states and localities will meet their responsibilities in taking advantage of the existence of these instruments. Further, without special provisions for transmitting data to regional headquarters response time would still be long. The capability of the system to meet the needs at this level is, therefore, rated poor.

Concept No. 11. AMOS system. In the Automatic Meteorological Observing System (AMOS) under development by the Weather Bureau (see section III.3.0), unattended weather sensors will be placed throughout the nation in a hexagonal pattern. Up to 1000 stations are planned as necessary to improve weather service, with 11 now in operation, and others in test. This system can be considered a special case of Concept No. 3. Entries in table I are based on use of only one radiation sensor per AMOS unit.

The systems that have been singled out for detailed study are Concept No. 3 and No. 8 since they seem most promising for meeting regional and national needs for a cost that is in the range of feasibility. In addition, a hybrid system is also considered that is a combination of these two. Such a hybrid system might be desirable if the shelter based system appears advantageous and if the likelihood of a program that would provide adequate nationwide coverage by this means seems low.

	Approx. Cost (Millions of Dollars)	Effectiveness (National and Regional Needs)	Effectiveness (Local Needs)	Response Time (National and Regional)	Response Time (Local)	Reliability	Flexibility	Implementation Feasibility	Invulnerability
1. Household Instruments	1,000	Poor	Very Good	Poor	Very Good	Good	Very Good	Very Good	Fair
2. Unattended sensors-dense	5,000 up	Very Good	Good	Good	Good	Very Good	Fair	Very Good	Good
3. Unattended sensors-sparse (15 mile spacing)	30	Good	Poor	Good	Good	Good	Poor	Good	Good
4. Metropolitan sensors-dense	5,000	Poor	Fair	Good	Good	Very Good	Fair	Fair	Fair
5. Metropolitan sensors-sparse	5	Poor	Very Poor	Good	Good	Good	Poor	Good	Fair
6. Target area sensors	6	Poor	Very Poor	Good	Good	Good	Poor	Good	Fair
7. Shelter sensors-dense	150	Good	Good	Good	Good	Very Good	Very Good	Good	Good
8. Shelter sensors-sparse	20	Good	Poor	Good	Good	Very Good	Very Good	Good	Good
9. Present system	6	Poor	Fair	Poor	Good	Fair	Very Good	Very Good	Fair
10. Augmented present system	20	Fair	Good	Poor	Good	Good	Very Good	Very Good	Fair
11. ANOS system using WREC	1	Fair	Very Poor	Good	Not Applicable	Very Good	Poor	Very Good	Good

Figure II-1. Radiological Monitoring Concepts



REFERENCES

- (1) Standard Metropolitan Statistical Areas. Executive Office of the President. Bureau of the Budget. 1961.
- (2) First Phase Results of Fallout Shelter Survey. News Release. Department of Defense. 11 May 1962.

SECTION III  
ELEMENT CONSIDERATIONS

A radiological monitoring system consists of sensor instruments to measure radiation intensities; communications links which connect sensor instruments to relay points; relay points which collect radiation intensity data from several sensors and put the collected data in the proper format for transmission to designated destinations; a communications network which provides the means for connecting relay points to Regional Headquarters and the National Center; and data processing elements to compute and display the information required at Regional Headquarters and the National Center. Human beings may be at different levels of the system for purposes of monitoring and decision making.

In an automatic radiation monitoring system all data gathering, communicating, and processing are performed without human intervention. In a manual system human beings are involved in functions other than decision making, e.g., data collection and transmission.

1.0 SENSORS

An analysis of sensor instruments and sensing techniques was performed to determine the sensor best suited to the needs of the system. Ion chamber, Geiger counter, scintillation counter, photoconductor, and semiconductor devices were evaluated.

As a result of examining the newer techniques under development, it was determined that none were sufficiently developed to provide the basis for design of a new instrument which would be available quickly.

To guide in the selection, criteria were assumed. It is required that the instrument:

1. Detect and measure gamma radiation dose rates over the range of 1 to 1000 R/hr. Higher and lower dose rates are of interest if the cost is not substantially increased.
2. Be capable of responding to any level of radiation within the required range in not more than two minutes.
3. Read within  $\pm 15\%$  of the true dose rate in cobalt - 60 and/or cesium - 137 gamma radiation fields incident normal to the top and normal to the side of the detection element.
4. Have an error (due to energy dependency) no greater than  $\pm 15\%$  of the true dose rate for any gamma radiation energy between 80 kev effective, and 1.2 mev effective with the radiation incident normal to the side and top of the detector element.
5. Have a response such that the difference in the indication for radiation incident normal to the side and to the top of the detector element does not exceed 15% over the photon energy range of 80 kev to 1.2 mev.
6. Be capable of meeting the response time requirements previously stated after one year without any radiation exposure.
7. Give an off scale indication when exposed to radiation dose rates greater than 1000 R/hr., and a "zero" indication when exposed to less than 1 R/hr.
8. Read within these accuracy requirements after any level and period of time of over-exposure.
9. Be capable of 30 day continuous operation under all weather conditions. The detector element and any other unprotected portions of the instrument must be designed to withstand blast pressures, temperatures, and radiation effects of nuclear weapons outside the 10 psi overpressure zone as a minimum.

10. Be capable of driving a microammeter or milliammeter to indicate the radiation level within the required limits at a remote location. A parallel output capable of driving an analog-to-digital converter should also be provided for cases of automatic operation.

Tabulations of available instruments appear in several publications, notably that by Edgerton, Germeshausen, and Grier, Inc. which appears in "Nuclear Fallout Prediction and Monitoring Systems". Quarterly Progress Report No. 2, by K. Humphreys, J. Handloser, and T. Dahlstrom.

#### 1.1 Sensor for Shelter-Based System

The CD V-711BX<sup>(1)</sup> is recommended for use without change for the Shelter-Based System. Because it was designed to have the sensing element exposed and the reading element protected, the present system use conforms very well to its planned application. Its cost, in production, is estimated at \$200 for the purpose of developing system costs.

#### 1.2 Sensor for Automatic System

The CD V-711BX, modified, is recommended for use with the automatic system. The extent of this modification may not be great but is necessary to allow it to be connected to an analog-to-digital converter for automatic operation.

The use of certain types of analog-to-digital converters require that the output of the sensing element be amplified. If a shaft position encoder (shaft digitizer) is used, a 1000 gain linear amplifier is necessary. If a solid state analog-to-digital converter is used, an amplifier will not be required. Present

costs of solid state converters, however, preclude their use. Therefore the shaft digitizer A/D converter is recommended, and an amplifier is required. Such converters are commercially available and are manufactured by Norden-Ketay, Kearfott, Bendix Corporation, and others. The outputs of the instrument should match the input characteristics of the AMOS as described in paragraph 3.2.1 of this section.

Estimated cost of the sensor and associated equipment is:

Sensor	\$200.00
Amplifier	45.00
A to D Converter	<u>150.00</u>
	\$395.00

## 2.0 SENSOR TO RELAY POINT COMMUNICATION

### 2.1 Shelter-Based System

In this system a person in a shelter will read the instrument and verbally transmit the reading to the Relay Point. Therefore, a shelter transceiver (voice radio) or a telephone will be used for this transmission.

Cost estimates do not include cost of this communications element, as it is anticipated that voice communication will be provided in group shelters for other purposes in the event that a substantial shelter program is undertaken. Attention has been given to shelter communication in other research sponsored by the Office of Civil Defense. (2)

## 2.2 Automatic System

The sensor to relay links investigated for the automatic system consist of both land line and radio facilities. In considering land line communications the use of existing facilities as well as the laying of new lines from sensor to relay were evaluated. In most cases the costs of such land line links proved to be too high. As a result, the communications link selected for the Automatic System consists of a radio transmitter-receiver<sup>(3)</sup> which accepts and transmits sensor data at intervals controlled by the interrogation of a receiving unit at the relay point. It is recognized, however, that for short distances, or where lines already exist, land lines would be used for this transmission. The interrogation sequences the transmitter at the sensor ON, and OFF again at the end of 30 seconds of transmission. The proposed equipment was selected as a result of evaluating equipment in existence or known to be in development. The selected equipment had cost and performance advantages over the others.

2.2.1 Sensor Transmitter-Receiver.—At each sensor a transmitter-receiver is required. The receiver is necessary in order to respond to commands from the relay point to turn the transmitter ON and OFF.

2.2.1.1 Sensor Receiver.—This receiver is a low power drain "bat-wing" microminiature unit. The unit turns itself ON and OFF at a megacycle rate. When it detects the presence of a signal while it is momentarily ON, electronic circuits lock the receiver ON until the message is completely received. The loss of a signal then returns it to its normal "bat-wing" operation.

2.2.1.2 Sensor Transmitter<sup>(4)</sup>.—The transmitter is a small transistorized unit powered by self-contained rechargeable batteries. The operating parameters are:

- |                       |  |
|-----------------------|--|
| - operating frequency | 2 to 8# mc crystal controlled                            |
| - modulation          | narrow band fm   |
| - coding              | modified frequency shift                                 |
| - range               | 30 to 50 miles under all weather and terrain conditions  |
| - stability           | one in 10 <sup>5</sup>                                   |
| - duty cycle          | intermittent   |
| - power output        | 10 watts cw power across a 50 ohm resistive load         |
| - power               | battery self-contained, rechargeable in a 14 hour period |

The transmitter is housed in a watertight carrying case. It is 14x9½x8½ inches in size, and weighs less than 30 pounds.

The antenna is a 30 foot slant wire ¼ wave at 8 mc, and requires no structures.

Costs of the transmitter and receiver which would be located at each sensing point are estimated as:

Transmitter	\$450.00
Receiver	<u>150.00</u>
	\$600.00

### 3.0 RELAY POINT EQUIPMENT

The functions of the Relay Point are to reduce the total length of communication channels, and to provide the proper interface between a group of sensors and the communications network.

These functions include: data collection, output message forming, generation of fixed data, and control of data entry into the communications network (on command from the network).

Two types of relays have been selected, one for the Shelter-Based System and the other for the Automatic System.

### 3.1 Shelter-Based System

3.1.1 Relay Equipment.—An individual in the shelter at the Relay Point will receive radiation intensity readings from six sensor locations (see paragraph 2.1 above) and record them (together with the intensity at his own location) by setting manual switches -- a set of three switches (3 digits) for each sensor.

He will record these intensities in the following manner:

<u>Meter Reading (R/hr.)</u>	<u>Switch Setting</u>
<.5	000
≥.5 and <998.5	Nearest integer
≥ 998.5 or off scale	999

These readings are transmitted to a weather observation station, and are entered into the FAA Service A network. (A weather observation station includes the necessary equipment to collect and format the data for entry into the FAA Service A network\*.)

The equipment at the Relay Point shelter consists of a set of switches, a commutator, control logic, and line matching devices. Figure III-1 is a block diagram of this equipment, and of the equipment described in paragraph 3.1.2 below.

\* See paragraph 4.0 for description of the FAA Service A network.

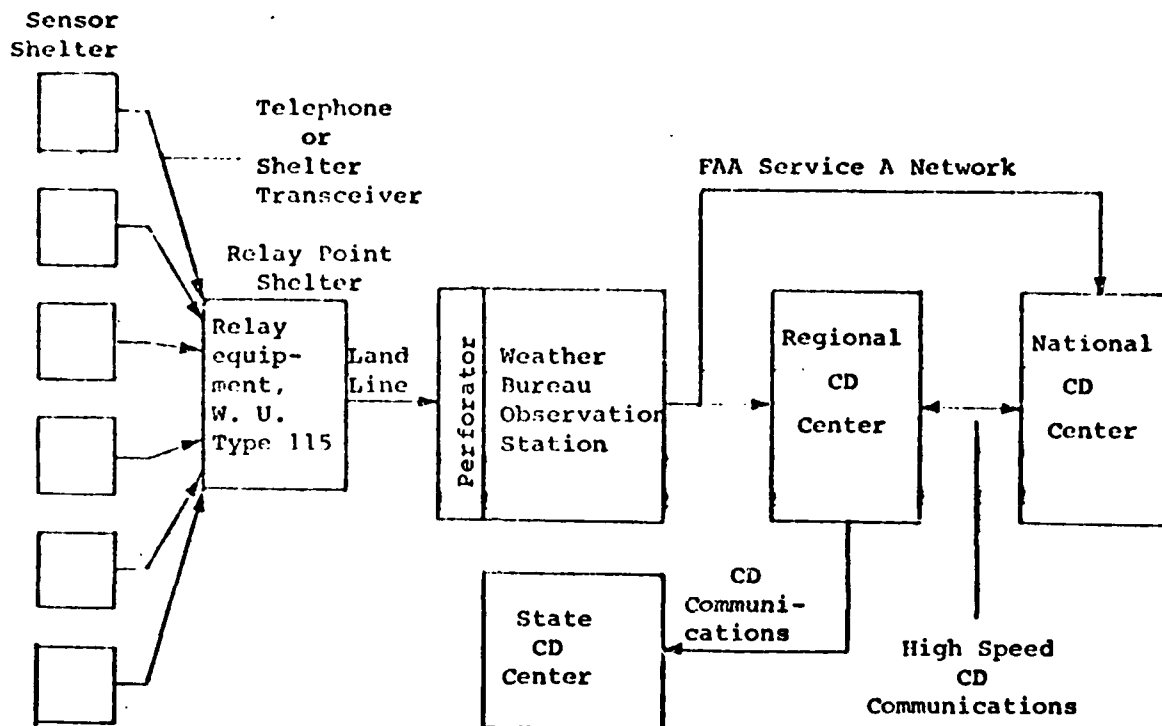

Figure III-1. Shelter-Based System, Block Diagram

Radiation data received from sensors are stored on the set of switches. The commutator provides a path for the transfer of the contents of the switches to control logic where the data are placed in proper form for transmittal.

A typical region will contain about 2500 sensor and about 360 Relay Points. Use of telephone or other verbal means for communication with this number of Relay Points would require too much time on the part of personnel at Regional Headquarters.

When the relay equipment receives a "transmit signal" from

the Weather Observation Station the data stored in the digi-switches\* are transmitted (by means of the Western Union Model 115 Transmitter) over low speed, 60 word-per-minute lines to the Weather Observation Station where the data are perforated on paper tape.

The estimated cost of this equipment is:

21 Digiswitches at \$15 each	\$315.00
commutator	125.00
control logic and line matching equipment	450.00
power supply	<u>30.00</u>
Total	\$920.00
Installation costs	60.00

3.1.2 Relay to Weather Observation Station Communications.—In the Shelter-Based System each Weather Observation Station will monitor a given number of relay points. For purposes of radiation monitoring, a Western Union Teletype Model 115 system will link each of these weather observation stations and the relay points reporting to it. The teletype system will be activated manually at given intervals of time and on an hourly basis by personnel manning the weather station. A "transmit pulse" will be sent from the teletype receiver at the observation station to each of the relays in a predetermined sequence. When the complete data has been received from the relay point just polled, another "transmit pulse" will be sent to the next relay point. This operation will be repeated until all relay points have been polled. If data are not transmitted by a polled relay point, the system would hold the line

\*Digiswitch is a trade name of switches manufactured by the Digitrans Company, 855 S. Arroyo Parkway, Pasadena, California

and wait a predetermined amount of time, then release the line and switch to the next relay point in the sequence.

**Cost.**—The lease of each Western Union Type 115 Receiver is \$150 per mo. The cost of the leased lines is given in paragraph 6.1.4.

### 3.2 Automatic System

3.2.1 Automatic Meteorological Observing System (figure III-2).—The Relay Points of the Automatic System are units of the Automatic Meteorological Observing System (AMOS).<sup>(5,6)</sup> These units were selected for this application because they meet the requirements developed in this study. AMOS is in production, and the Weather Bureau plans call for its extensive deployment in the weather network.

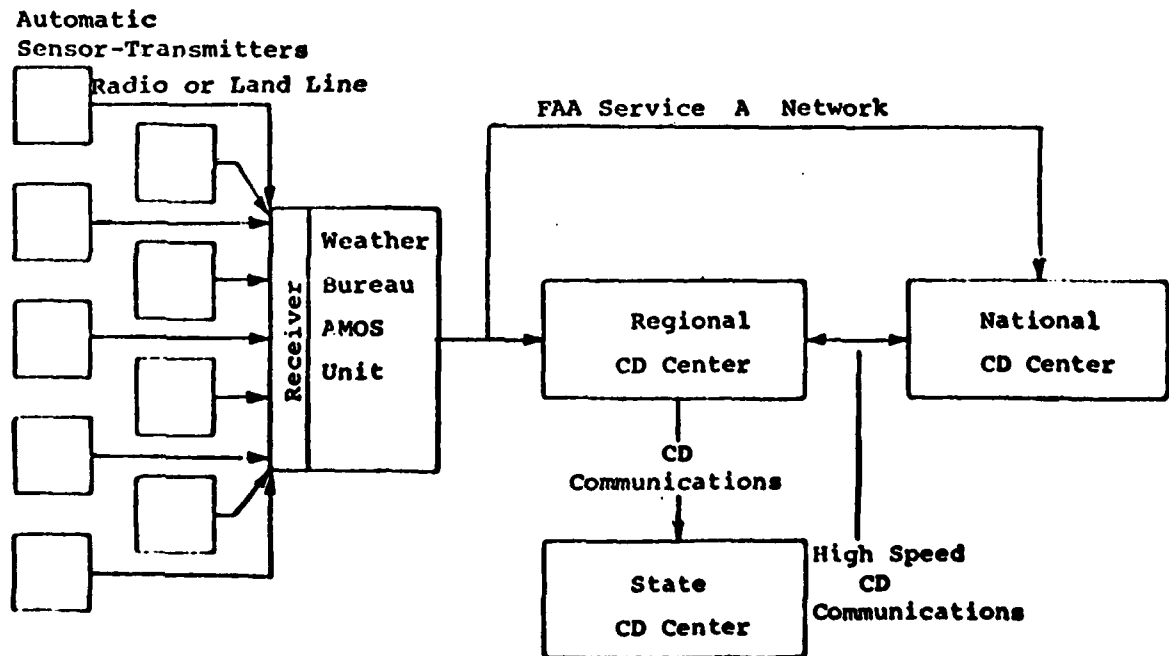

Figure III-2. Automatic System, Block Diagram

AMOS is an automatic data monitoring, processing, and transmission system developed by the Weather Bureau for either attended or unattended operation. It is integrated into the FAA Service A network for weather data gathering purposes.

Eleven stations are presently in operation, others are in test, and it is planned that 600 to 1000 will be deployed across the nation in the next few years. Present plans call for the AMOS to be distributed in a hexagonal arrangement with 50 to 75 mile spacing.

This equipment can monitor up to 100 separate instruments. Input, output, and processing are completely asynchronous. Presently 14 of 100 channels are used. AMOS can be connected to a 100 word-per-minute or 1000 word-per-minute teleprinter circuit for transmission by wire or by radio.

Presently monitored are instruments which gather data on visibility, cloud height, temperature, dew point, wind direction, wind speed, pressure, and precipitation. Data are gathered on a 10 minute cycle for purposes of air traffic control. When operating as part of the Service A Network, either the last gathered data are transmitted, or a special monitoring is performed depending on how recently the last data were gathered.

The present weather instruments may be as far as 4 miles from the AMOS and are connected to it by means of wire and cable. The instruments are independently powered. Each instrument is individually addressed and its data are accepted in analog form, converted, and placed in a predetermined storage location (drums provide the storage media). A computer then extracts this data, processes it, and stores it again in another predetermined drum

location. The computer arranges the data in the proper format. Once the data is in "output storage", it can be transmitted asynchronously and independently of the computer.

By means of a teletypewriter located at the Control Console of the AMOS, information can be added to that collected by AMOS. Such data can be placed, automatically, at any location in the message.

If data from a sensor is missing AMOS leaves that slot in the message blank.

AMOS has the following input characteristics:

sampling rate -	up to 35 samples per second per channel
input signal amplitudes -	0 to -12 volts
input form -	Parallel up to 12 bits or serial by bit
input control -	on demand by AMOS or asynchronous input

The AMOS has a 10 wire decimal to binary coded decimal converter to handle data from existing instruments.

An AMOS unit requires about 1 kw of power. It does not have a self-contained standby power supply. However, in all attended installations standby power is provided. In the automatic system the radiation sensors would feed data directly into AMOS (via the radio links described in section III.2.2). The radiation data would be accepted by AMOS in a predetermined sequence and integrated into the weather data. The complete message is then formatted and stored before transmission.

The production cost of an AMOS unit is expected to be approximately \$34,000 (AMOS IV). Unless an AMOS unit were used exclusively for radiological monitoring, the cost to the Department of Defense should be considerably less. For this study the cost is computed on the basis of the number of input lines or channels to be used. One channel would be needed for the radiation data. Since AMOS has a capacity of 100 channels, the cost of one channel would be:

$$\frac{34,000}{100} = \$340.00 \text{ per AMOS unit.}$$

It is anticipated that the final cost of AMOS service to the Department of Defense would be based on negotiations.

3.2.2 Relay Point Receiver and Transmitter.—At each relay point (AMOS location) a receiver, a transmitter, and a timer will be required. The function of the transmitter is to activate the sensors for transmission in a predetermined sequence. The function of the receiver is to accept the data transmitted by the sensors and forward them to the AMOS for storage purposes. The timer is necessary in order to synchronize sensor transmission with the communications network.

3.2.2.1 Receiver.—The Relay Point receiver is also a transistorized unit powered by self-contained rechargeable batteries. It is of single conversion superheterodyne design.

The operating parameters are:

- |                     |                                      |
|---------------------|--------------------------------------|
| - sensitivity       | 160 dbw from 50 ohm source           |
| - frequency range   | 2 to 8 # mc crystal controlled       |
| - stability         | 1 part in $10^5$                     |
| - spurious response | 60 db below that of desired response |

The receiver is 14x9x8½ inches in size.

The detachable antenna is approximately 10 feet long. The actual alignment of each antenna provides a reflected skywave beamed at its receiver. This focused beam results in very low signal levels at points other than the focus. The low signal level eliminates interference from distant sensors utilizing the same frequency.

Cost of the receiver at the relay point is estimated at \$700.00.

3.2.2.2 The Transmitter.—The transmitter characteristics are the same as those described earlier in section III.2.2.1.2. Allocation of frequencies is discussed in section IV.4.2.

The cost of this transmitter is estimated at \$450.00.

#### 4.0 COMMUNICATIONS

In selecting the communications network best suited to meet the requirements of the radiation monitoring system, a number of existing networks were examined. These networks were: common carrier networks, military networks, and government owned non-military networks. Among those examined for their suitability were the Western Union system, the Defense Communications Agency Data Communications system, the DCA Switched Communications Automatic Network\* (SCAN), the General Services Administration Network, the Federal Aviation Agency Networks A, B, & C, and the National Warning System Network.

---

\*The NACOM 1 Network has been incorporated into SCAN and, therefore, it was not examined independently.

Existing networks were examined for possible applicability rather than pursuing the design of a special network for radiation monitoring because of the prohibitive cost. To indicate a magnitude of this cost, the required network would be of the same order as the FAA Service A Communications system which is presently leased by the Weather Bureau for about \$500,000 to \$600,000 a year at TELPAK rates. These costs become specially significant when it is realized that during peacetime utilization of the network for radiation monitoring would be low.

To guide the selection of the proper network certain criteria were developed:

- a. The geographic distribution of the selected network should be adequate to meet the nationwide sensor distribution.
- b. The network should be capable of carrying the additional post-attack traffic load due to monitoring.
- c. The required circuits within the network should be available to carry the radiation data when required.
- d. Costs of the network should be minimal. These costs include initial costs and operating costs.
- e. The selected network should interface readily with other parts of the monitoring system.
- f. The operational discipline of the selected network, e.g., message formats, should be applicable with little or no modification, to the monitoring system.
- g. The network should be able to survive because it is hardened and/or can provide alternate routing.

On the basis of these criteria, the Western Union Network was rejected because it did not meet criteria d. and f. The DCA Data Communications and SCAN were rejected because they did not meet criteria a., b., and c. The General Services Administration Network was rejected because it did not meet criteria

a., c., e., and f.

The National Warning System was rejected because it did not meet criteria a., e., and f. The FAA Services B and C were rejected because they did not meet criteria a., b., and c.

All the networks investigated meet criteria g. to some degree. Certain networks, e.g., SCAN, are superior in alternate routing capability, other networks, e.g., GSA network, have hardened switching centers.

The Service A Network possesses some alternate routing capability. The destruction of the five switching centers will not totally incapacitate the network because the thirty Send/Receive Centers can perform some switching functions. On the other hand the Service A Network may not represent as important a military target as some of the others.

The FAA Service A Network was selected because it appeared to best meet the selection criteria. In addition, development of AMOS by the Weather Bureau for incorporation into the Service A Network makes the choice of this network appropriate.

In addition to meeting the selection criteria, the FAA Service A Network had a practical advantage, because it serves as the basic weather distribution network in the United States. In the post-attack period, one of the most important uses for weather data will be to predict fallout for civilian defense. Fallout predictions cannot be made without weather information.

#### 4.1 The FAA Service A Network <sup>(7)</sup>

FAA Service A is a nationwide teletype network utilizing

100 word-per-minute circuits, except for transcontinental 1000 word-per-minute express circuits which link the Interchange Centers. The network consists of 15 area circuits and 14 supplemental circuits. It is a broadcast type of service with 400 receive/transmit terminals and 2400 receive-only terminals. There are presently 600 weather observation points in the system. Fig. III-3 is a map of the system.\*

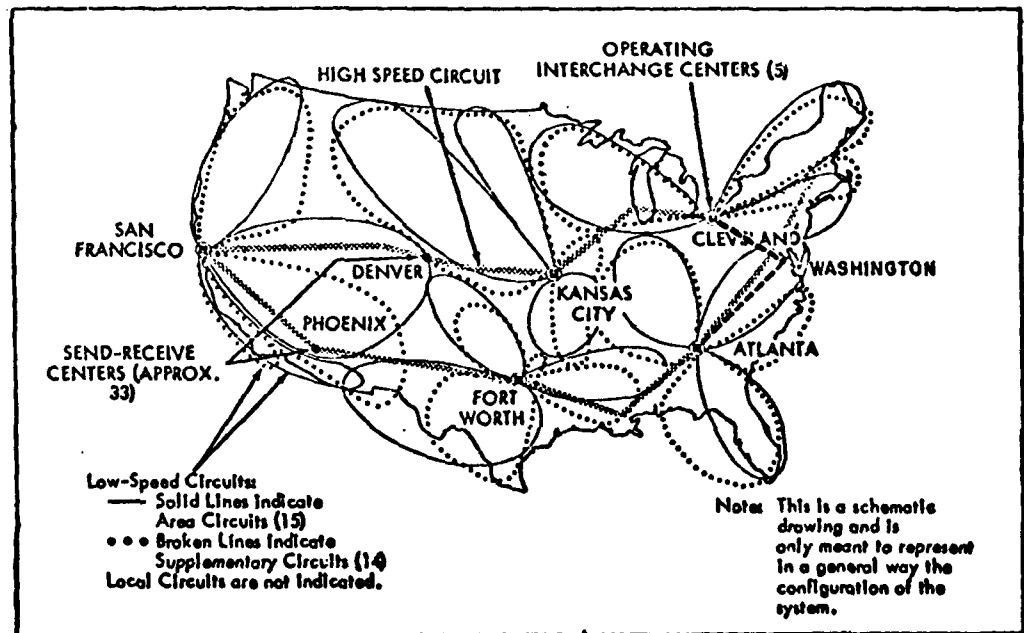

Source: Automatic Data Interchange System  
 Federal Aviation Agency  
 ATS Manual, 1961

Figure III-3. Service A System Map

\*For a more detailed system map see "Service A Weather Schedules", Federal Aviation Agency, ATS Manual.  
 For a map showing locations of weather observation stations in the U. S. see Weather Bureau Map 1806 "Meteorological Services in the U. S.".

#### 4.2 Interchange Centers<sup>(8)</sup>

The Service A Network is served by 5 Interchange Centers. One of these, the Kansas City Interchange, serves as Net Control Station. The other interchange centers are at Cleveland, Ohio; Atlanta, Georgia; Fort Worth, Texas; and San Francisco, California. The Fort Worth Interchange is the alternate Net Control Station. Each interchange controls three area and three supplementary circuits (except that the Kansas City Interchange controls two supplementary circuits).

In addition to the five interchange centers there will be thirty Send/Receive Centers located in major cities. In the event of malfunctioning of the interchange center, certain Send/Receive Centers can accept the responsibility of controlling circuits to which they are connected. Send/Receive and Interchange Centers are interconnected by high speed party line circuits.

Each Interchange Center and Send/Receive Center is capable of identifying up to 1100 message-identifying and line-control sequences.

Alternate routing, within limits, is possible. Service A is not a hardened network.

#### 4.3 Message Formats

The message format proposed for the radiation system would follow the pattern presently used by Network A. The sensor data would be appended to the end of the weather message, with a "header character" preceding the sensor data. Radiation data would follow in groups of three characters for each sensor (to

permit readings from 000-999). The header character serves the purpose of identifying to the processing system the nature of the radiation portion of the message.

The radiation data would be monitored in a predetermined sequence, and the AMOS unit would format the radiation data to be transmitted in the same sequence as collected.

#### 4.4 System Operations

4.4.1 Present Weather Observation System.—At each observation station where weather data are collected a tape is perforated and placed in a transmitter distributor. Automatic Program units at each Interchange Center initiate the operations by polling each of the collecting stations associated with each area circuit in a predetermined sequence.

Within a four minute interval all the weather data are collected from the area circuits and stored, after each message is prefixed to determine destinations, at the interchange centers waiting for dissemination. Upon completion of the data collection the Net Control Station (Kansas City) polls each of the fifteen area circuits sequentially, and information stored at the Interchange Center serving the area circuit polled is transmitted over the high speed circuits to the destinations identified by the message prefix.

Priorities exist with respect to the collection of observations on the Area circuits and on the delivery of the collected information from the high speed circuits back to the Area and supplemental circuits.

The network carries both the scheduled hourly sequence collections and the unscheduled sequence collections.

4.4.2 Radiation Monitoring System.—The System Operations will remain the same. The radiation data will be collected at the same time as the weather data, either by means of an AMOS or through the observation stations.

The data in its entirety will be transmitted over the Service A high speed links to Cleveland and Atlanta and from there by means of two additional high speed (1000 words per minute) lines to the National Center. It is estimated that it will take a few seconds for the computer at the National Resources Evaluation Center to process this data.

These two high speed lines which will connect the Cleveland and Atlanta Interchanges with the National Center shown in figure III-3 (heavy dotted lines) are additional lines which would have to be procured.

The collection of radiation data will introduce additional time delays into the weather system operations. The extent of this delay is dependent upon the number of sensors reporting to a given interchange. This is discussed further in Appendix B.

It is further proposed that all the Regional Headquarters become drops on the Service A Area circuits which serve the Region so that regional radiation data may be made available there.

#### 4.5 Cost Estimates

The estimated rental costs of the additional high speed lines

from the Atlanta and Cleveland Interchanges to the National Center are:

\$36,000/year.

The estimated rental costs of making the eight Regional Headquarters drops on the low speed area circuits serving their respective regions are:

\$24,000/year.

Total, \$60,000/year.

## 5.0 DATA PROCESSING

### 5.1 National Level

At the National Resource Evaluation Center a variety of mathematical models are available to estimate effects of an attack on resources.<sup>(9)</sup> Included are models which predict fallout, and estimate the effects of fallout on personnel, livestock, and other resources.<sup>(10)</sup> <sup>(11)</sup> Computations are made on a large data base existing at NREC<sup>(12)</sup> using weather and nuclear burst information obtained at the time of the attack. Monitored radiation intensities are not presently used in making these computer calculations.

The introduction of monitored data into the fallout calculations would require that the fallout model be reformulated and reprogrammed. Improved fallout predictions may be expected to result from such revisions. The program should be written to permit any radiation intensity data available at a given time to be used, even if that is not all the data which might be received. Computations would therefore not be delayed if complete data were not available.

Monitored intensities would be received at hourly intervals. These monitored intensities, weather information, and nuclear burst information, would be used in making the fallout predictions from which resource evaluation calculations are made.

Procedures would call for readings of sensors to take place at prescribed times. One possibility is that all sensors be read on the hour. These readings would be received in one group at National Headquarters and would be related to the reading time by the computer there.

An interrogation technique should be provided at National Headquarters to permit the best system estimate of the intensity at any specified point in the nation to be obtained.

It is desirable, too, that the National Center be prepared with computer programs for the processing described below for Regional Level, in order that it may serve as backup in the event that one or more Regional Headquarters are destroyed.

Although some of the details are classified, the nature of existing and planned computing equipment at NREC is such that no new problems of computer capability would arise from these recommendations.

## 5.2 Regional Level

At each of the eight regional headquarters, data from approximately 2500 sensors would be received once per hour. Relation of these readings to the time they were made would be done at the Regional Headquarters.

The data processing to be performed at regional level consists of taking this input and producing outputs suitable for planners and decision makers.

Suggested outputs are as follows:

5.2.1 Intensity Versus Location.—A method of describing intensities at various locations is needed at regional headquarters. A concept of zone boundaries is introduced as a generalization of the concept of iso-intensity contours. This is done because the "iso-intensity" contours used in practice commonly differ substantially from theoretical iso-intensity contours.

All parts of an area (see figure III-4) are classified by zones  $Z_i$ ,  $i=0, 1, 2, \dots, n$ , where the zone  $Z_i$  is defined to contain points  $p$  at which the radiation intensity at time  $t$ ,  $I_{Z_i}(p, t)$  is, with probability  $\pi_i$ , in the range

$$I_i \leq I_{Z_i}(p, t) \leq I_{i+1} \quad \text{for } i = 1, 2, \dots, n-1$$

and

$$I_{Z_0}(p, t) \leq I_1$$

$$I_{Z_n}(p, t) \geq I_n$$



Figure III-4 Zone Boundaries

The intensity levels  $I_i$  which define the zones are arbitrary but could be related to criteria for the degrees of hazard that are pertinent to the required decisions.

In the case where  $\pi_i = 1$  for  $i = 0, 1, \dots, n$ , the zone boundaries become iso-intensity contours.

The accuracy of the information can be specified in principle in terms of the distribution of the error  $X$  where

$$\begin{aligned}
 X_{Z_i}(p,t) &= I_{Z_i}(p,t) - I_{i+1} && \text{if } I_{Z_i}(p,t) > I_{i+1} \\
 &= I_{Z_i}(p,t) - I_i && \text{if } I_{Z_i}(p,t) < I_i \\
 &= 0 && \text{otherwise}
 \end{aligned}$$

The probability density of  $X$ ,  $f(X)$ , is discontinuous at  $X = 0$ , as illustrated in Figure III-5, where

$$f(0) = \pi$$

and

$$\lim_{a \rightarrow 0^-} \int_{-\infty}^a f(x) dx + \lim_{a \rightarrow 0^+} \int_a^{\infty} f(x) dx = 1 - \pi$$

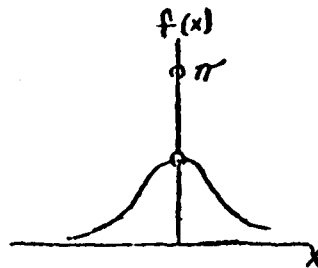

Figure III-5 Probability Density of Errors

Zone boundaries of this type should be derived at each regional headquarters for that region.

In addition to information about present intensities, predictions of future intensities should be made. Suggested prediction times are eight hours in the future and twenty-four hours in the future. These predictions would be based on data from the monitoring system, weather information, and nuclear detonation information available at regional level. Development of a computer program to perform such prediction is a desirable objective of further research, as is discussed in section VI.4.

5.2.2 Population Versus Intensity,— This would consist of a frequency distribution, plotted as a histogram, showing the estimated percent of the population receiving various intensities. It would be generated by the computer, based on monitored intensities and previously stored population and shelter information. A format for this histogram is shown in Figure III-6. Separate

estimates should be available for the region as a whole and for each state in the region; both for the present time and for 24 hours in the future.

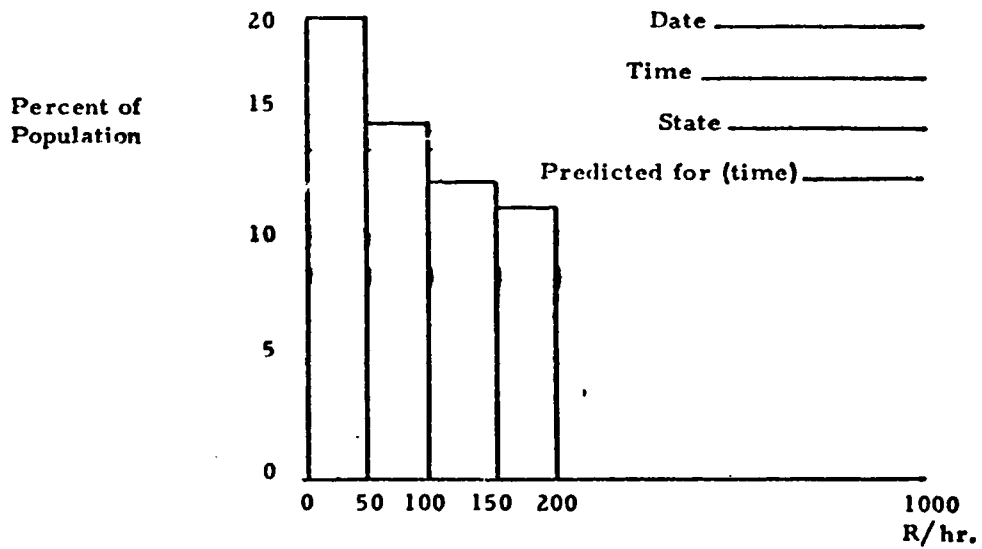

Figure III-6. Population versus Intensity (Hypothetical Data)

5.2.3 Population Dosage.—This would consist of a histogram showing the estimated percent of the population having received various doses. A sample format is shown in figure III-7. Here, too, separate estimates should be available for the whole region, and for each state in the region. Dose to the present time, estimated dose to 24 hours in the future, and estimated dose to infinity are desirable.

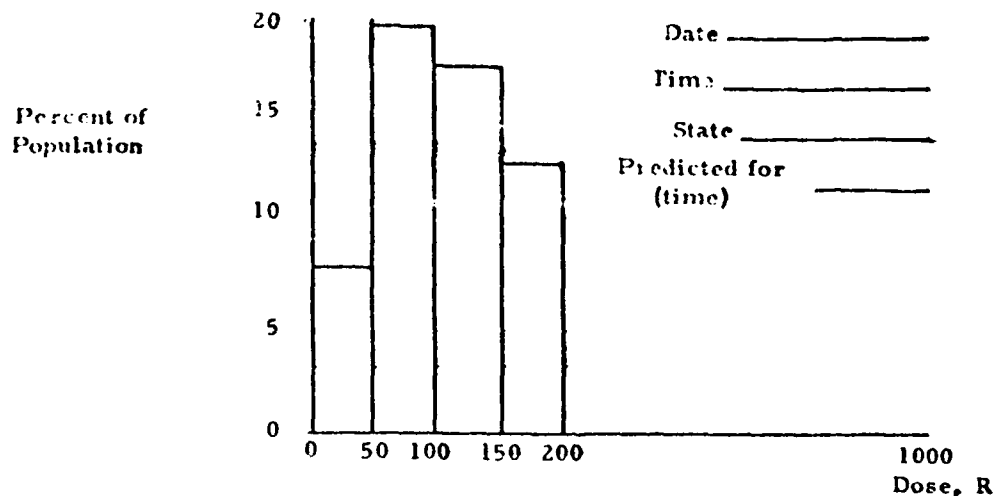

Figure III-7. Population Dosage (Hypothetical Data)

5.2.4 Interrogation.—An interrogation technique should be available which permits the best system estimate of the intensity at any point in the region to be obtained.

5.2.5 Computing Equipment.—Processing of data to derive these outputs would require use of a digital computer at each regional headquarters. Exact characteristics of this computer depend partly upon the complexity of the fallout prediction program recommended for further research. However, a technical judgment can be made as to the parameters of the computing equipment required.

The computer should be of the medium size scientific type. The following characteristics are recommended:

Add Time:	40 microseconds or less.
Cycle Time:	20 microseconds or less.

Memory:	16,000 words or more.
Word Size:	20 bits or more.
Tape Units:	2 or more.
Paper Tape Reader:	500 characters per second or more.
Printer Speed:	600 lines per minute or more.
Floating Point Arithmetic	

Examples of computers meeting or exceeding these specifications are the RCA 4102, GE 225, and IBM 7040. These computer systems have typical monthly rentals in the \$7,000 to \$14,000 range and purchase prices in the \$350,000 to \$700,000 range. For cost estimating purposes, a computer complex with a purchase price of \$600,000 will be assumed in each regional headquarters.

### 5.3 State Level

It is recommended that the radiological monitoring system not be dependent on computers at state level. It is hardly possible that all states could be convinced of the desirability of acquiring the same model computer, and implementing it in a uniform manner.

### 5.4 County Level

There is variation from state to state in the structure of the civil defense organization. At levels between state and local, however, computing equipment is not recommended. In order to make good use of a computer, rapid data gathering means would have to be provided. The combination of computer and monitoring system costs for county level is prohibitive. A monitoring system aimed at national and regional needs will result in too few data points per county to permit meaningful processing.

## 5.5 Local Level

Two situations exist at local level, with respect to data processing.

Most local centers will not have a computer, and will monitor and process manually. These local centers may want to arrange to receive measurements from stations of the national and regional monitoring system, but these stations will be too sparsely distributed to meet local data needs. Local decisions in these centers will be based on manual monitoring, hand-drawn iso-intensity contours, and hand calculations and predictions.

A second situation is that of a large city with a high population density. Such a city can afford to make precise plans for monitoring and processing radiation data, since it has a relatively small area to monitor and a large number of persons who would benefit from high quality processing of data by a computer. The computer would be used for calculation of zone boundaries and frequency distributions for different sections of the city, together with other non-radiological Civil Defense uses.

## 5.6 Local Averaging

Below regional level all the data obtained through the radiation monitoring system (from the 20,000 sensors) are passed upward as they are sensed without reduction or processing. This does not include data which has been collected by other means, such as mobile monitoring, aerial surveillance, etc. High speed computers at the National and Regional Centers can process this data in several seconds.

It is not desirable to average local readings before forwarding because averaging is an information-losing process and any loss should be compensated by an increase in number of sensors (to meet a given accuracy). For example, a computer may be asked to give the best estimate available of the intensity at a specific point P (see figure III-8). If no local averaging has been performed, this estimate may be derived from the four (or even more) closest sensors. (In this example a square grid is assumed.) If local averaging of each four sensors had occurred the estimate would have to be based on the averages indicated. Nevertheless, with no local averaging, the local averages may be computed rapidly if these averages themselves are wanted at national or regional level.

If provision of extra sensors and local communications were cheap and higher level communication capacities were overtaxed, such local averaging would be desirable. However, this is not the case in the recommended systems.

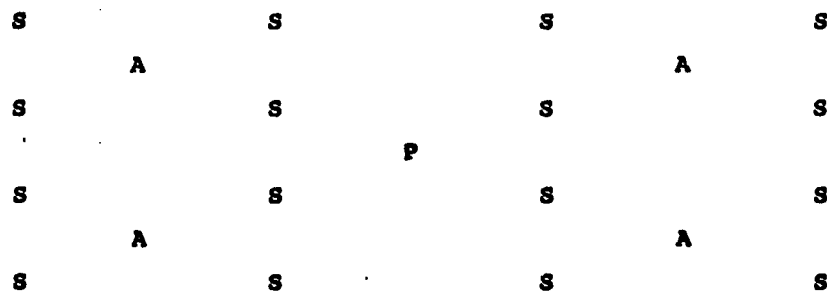

S: Sensor  
 A: Average  
 P: Point of Interest

Figure III-8. Local Averaging

## 6.0 DISPLAY

Possible uses of displays include information presentations for human decision making, for selecting data to be processed, for graphically correlating information, and for showing the status of the system or its components. At various levels, radiological information will be displayed for one or several of those reasons. Displays may also be useful for many reasons other than those relating directly to radiological information. These include weather presentations, damage areas, fire areas, resource points, and rescue team locations. At the highest level, complex display systems will be shared by many kinds of information. The kind of display possible at any level will in part depend upon the equipment available to drive it.

a. At national level, monitored information will be processed to produce the various outputs required by policy makers. Processed information would be stored and displayed to the decision-making group as they call for it. Adequate equipment is now in existence.

b. At regional level, manual plotting is possible, but not desirable. Because of the number of data points which would occur in a region, it would be difficult to keep up with the plotting load. With a computer at regional headquarters, an on-line (directly connected) display device would be best. Therefore, in order to avoid expensive, specially developed display equipment, an X-Y plotter with line-drawing capability is recommended. This device would be used for displaying the information described in Section III.5.2. Inexpensive reproduction and projection equipment should be available to make these plots available to numbers of persons.

Sizes of plotters vary, with plotting boards up to 5'x10' and 5'x12' available. Minimum size recommended for the present application is 4' by 4'.

Prices vary over a wide range. A nominal \$40,000 is used to estimate the cost of the proposed systems.

c. At state and county levels, manual plotting is adequate. Iso-intensity contours will be drawn by connecting plotted points. Overlays may be used to correlate graphically other kinds of data such as blast points, population concentration and the like.

d. For local levels, hand plotted boards or maps suffice. Even in the case of large cities, hand plotting is feasible.

e. For shelter levels, a simple board is adequate to keep track of local conditions.

#### REFERENCES

- (1) Radiological Survey Meter CDV 711 BX. Nuclear-Chicago Corp. 15 November 1962. Contract OCD-OS-62-197.
- (2) Fallout Shelter Communications Study. Gautney and Jones. Dec. 1962. Contract OCD-OS-62-123.
- (3) Micromodule Program. Surface Communications Div. RCA. Camden, N. J. Contract #DA-36-039-SC-75268.
- (4) Narrow Band Communications. 30 November 1962. RCA Surface Communications Division, Tucson, Arizona.
- (5) Automatic Meteorological Observing System, United States Department of Commerce, Weather Bureau, Specifications No. 460. 1504. October 15, 1961.
- (6) Automatic Meteorological Observing System. H. R. McBirney. Paper presented at Instrument Society of America 17th Annual Conference. October, 1962.
- (7) Service A Weather Schedules, AFS Manual, Federal Aviation Agency. Transmittal #7.
- (8) Automatic Data Interchange System. Federal Aviation Agency. Catalogue No. T414, T404.
- (9) Nuclear Attack Hazard and Resource Evaluation Models. Dr. Joseph D. Coker, National Resource Evaluation Center, October 18, 1961.
- (10) Demographic Facets of Nuclear Warfare. Dr. Joseph D. Coker, National Resource Evaluation Center, May 4, 1962.
- (11) Analytical Program Compendium. National Resource Evaluation Center, April, 1962, NREC Technical Manual No. 119.
- (12) Resource Data Catalogue. National Resource Evaluation Center, April, 1962, NREC Technical Manual No. 120.

SECTION IV  
SYSTEM CONSIDERATIONS

1.0 APPLICATION

Elements (equipment items) which make up the system should be evaluated as soon as possible after system concepts have been determined because element characteristics will affect the detailed design of systems which use them as building blocks. In addition, the limitations of elements will affect the general considerations which apply to all systems.

Before systems can be described in terms of operational doctrine and personnel requirements and costs, some general limitations which apply to all systems must be considered in some detail. These limitations are in terms of density of sensors required and in terms of inaccuracy of dose rate knowledge resulting from the presence of small scale effects.

The approach to these problems stems from the questions to be answered in both cases and from the availability of basic data. In regard to sensor density the question may be phrased: With a given grid size, what is the accuracy of information obtained?

Two questions had to be answered concerning small scale effects. The first was whether small scale effects were so overriding that they masked the larger effects; the second concerned possible ways in which the effects of individual bias of location upon the sensor could be countered. The first question was answered negatively and the second was attacked by constructing an idealized model in which individual influences were considered. From the model, a

series of statements was generated to define the selection of locations and a technique was developed for weighting out factors by which possible locations deviated from the ideal.

## 2.0 SPACING

A critical parameter for any fixed station radiological monitoring system is the distance between sensors. Attempts to determine this parameter intuitively have led to widely varying suggestions. Therefore, it was considered necessary to quantify the factors which influence the accuracy versus spacing relationship and to determine the combined effect of these factors by means of computer simulation.

The objective of the simulation was to determine the relation between sensor spacing and the accuracy of estimates of radiation intensities based on sensor measurement.

To do this two radiation patterns were selected. Pattern I was based on 49 bursts of 5 megatons each in central California in winter. Pattern II was based on a 5 megaton burst over New York City. For the selected two patterns, the radiation intensities were recorded at points spaced at intervals of one (1) mile and one and one half (1½) miles respectively for Patterns I and II.

A large number of points were then selected to represent points of interest to decision makers. The radiation intensities at these randomly selected points were derived from these recorded intensities. Then the intensities were estimated at these points by using one of two methods. In one, data from the nearest sensor were used, if the sensor was operative, or measurements from four (4) surrounding sensors were averaged and used, if it was inoperative.

In the other, the measurements from the four (4) surrounding sensors were averaged. However, each sensor measurement was weighted by a factor inversely proportional to its distance from the point of measurement

In addition, in computing the estimated intensities, sensor spacings (of 5,10,20, and 50 miles), simulated instrument errors, simulated instrument damage, and small scale effects (section 3.0) were introduced selectively and in combinations. Thus, for every randomly selected point, the simulated intensity, and the simulated sensor reading were derived. Following this, the relative error for each of these selected points was determined.

The results of this simulation, therefore, appear as a set of curves which give frequency distributions of relative errors under different conditions of sensor spacing, pattern of nuclear burst with or without small scale effects, and mode of estimating intensity.

The RCA 301 computing system was used for this simulation.

## 2.1 Description of Simulation

At each point (J,K) of a set of points randomly selected from an area covered by a fallout pattern, an estimate of the radiation intensity (dose rate) is made, based on measurements

from a network of sensors. A square grid is used because it substantially reduces the programming required. The estimate  $W(J,K)$  is compared with the actual intensity  $W(J,K)$  and the relative error

$$E(J,K) = \frac{W(J,K) - W(J,K)}{W(J,K)}$$

computed. The error is designated "Type 1" if the actual intensity,  $W(J,K)$ , is within the range which the system can measure and transmit. This range is assumed to extend from 0.5 R to 999 R. The lower limit is the smallest intensity that will be distinguished from zero; the largest is determined by the range of the measuring instrument and the system for transmission of the data. The error is designated "Type 2" if  $W(J,K)$  is less than the lower limit and "Type 3" if  $W(J,K)$  is equal to or greater than the upper limit.

Data are also obtained which indicate with what accuracy it can be estimated that the dose rate is within a specified range. Zones of radiation intensities are defined; for example, Zone 1 may correspond to those points at which the intensity is less than 1 R, Zone 2 between 1 R and 10 R, etc.

The point (J,K) is estimated to be in the ith zone which has zone boundaries,  $B_{i-1}$  and  $B_i$  if

$$B_{i-1} \leq \hat{W}(J,K) < B_i$$

and the error is defined to be

$$\begin{aligned} X(J,K) &= B_i - W(J,K) && \text{if } W(J,K) > B_i \\ &= B_{i-1} - W(J,K) && \text{if } W(J,K) < B_{i-1} \\ &= 0 && \text{otherwise} \end{aligned}$$

For both  $E(J,K)$  and  $X(J,K)$  a negative value indicates an error of underestimation of the intensity.

The simulation provides for two alternative methods of making the estimate  $\hat{W}(J,K)$ . The Mod I version obtains the estimate by using the measurement at the nearest sensor, if it is operative. Sensors become inoperative either due to a malfunction, whose probability of occurrence is specified as an input parameter, or due to blast damage. The points at which a sensor would be destroyed by blast are specified. If the nearest sensor is inoperative, the measurements of the four surrounding sensors (or less if one or more is inoperative) are averaged. If all four of the surrounding sensors are inoperative it is assumed that this is probably a region of heavy blast damage and the

estimate is set equal to the upper limit of radiation intensity that the system can measure.

The Mod II version of the simulation obtains the estimate  $\hat{W}(J,K)$  by averaging the measurement at the four (or less if one or more is inoperative) sensors surrounding the point (J,K). Each measurement is weighted by a factor that is inversely proportional to the distance from the point (J,K) to the sensor. Again if all four sensors are inoperative, the estimate is set equal to the upper limit.

A fallout pattern is specified by means of a matrix which gives the radiation dose rate at a set of discrete points in a two-dimensional array. The size of the area represented by the matrix is arbitrary. A network of sensors arranged in a square grid is defined by specifying the spacing between sensors, D, and the position of the fallout pattern relative to the sensor network. This position is randomly selected by sampling from a uniform distribution with range (0,D) to obtain the abscissa and ordinate of the "radiation data axes" with respect to the "sensor axes" and sampling from a uniform distribution with range  $(0, \pi/2)$  for the angle between the axes of abscissas of the two sets of axes. At the beginning of a simulation run the computer is instructed to use a specified number of different orientations of the fallout pattern with respect to the sensor network and to compute  $W, \hat{W}, E,$  and  $X$  at a specified number of points for each orientation. In most of the results reported here for a given set of problem parameters either 20 or 40 orientations were used with five points per orientation, for a total of either 100 or 200 points. For each set of parameters, the same sequences of pseudo-random numbers\* were used in an effort to have "chance" affect the system in approximately the same way for each set of problem parameters.

\*The pseudo-random numbers were generated by the algorithm

$$X_i = kX_{i-1} \pmod{p} \text{ with } k = 5^{13} \text{ and } p = 2^{35} - 31. \quad (1)$$

## 2.2 Simulation Parameters

The object of the simulation is to obtain insight into the effect of certain inputs to the simulation on the distribution of errors  $E(J,K)$  and  $X(J,K)$ . The following parameters were varied:

- a. The fallout pattern, reflecting different assumptions as to the number of bursts, time after burst, and "small scale effects".
- b. The sensor spacing.
- c. The method of using the sensor measurements to obtain estimates of intensity at points other than sensor points.
- d. The probability of malfunction of a sensor and/or its associated relay link.
- e. The distribution of sensor measurement error.
- f. The zone boundaries.

Two fallout patterns were used and the simulation was conducted with each of them alternatively modified or unmodified by small scale effects. The first pattern, designated Pattern 1, represents dose rates 1 hour after 49 bursts of 5 megatons each in Central California in a winter season<sup>(2)</sup>. Isodose-rate contours from this pattern are shown in figure IV-1. The data used in the simulation represent dose rates at one mile intervals over a 100 mile square. The range of intensities is 0.0 to 9400.00 R/hr. before introduction of small scale effects.

The second pattern, designated Pattern 2, represents dose rates 24 hours after a 5 megaton burst over New York City<sup>(3)</sup>. This pattern, for which isodose-rate contours are shown in figure IV-2, was specified by dose rates at one and a half mile intervals over a rectangle of 240 by 90 miles. The range of intensities

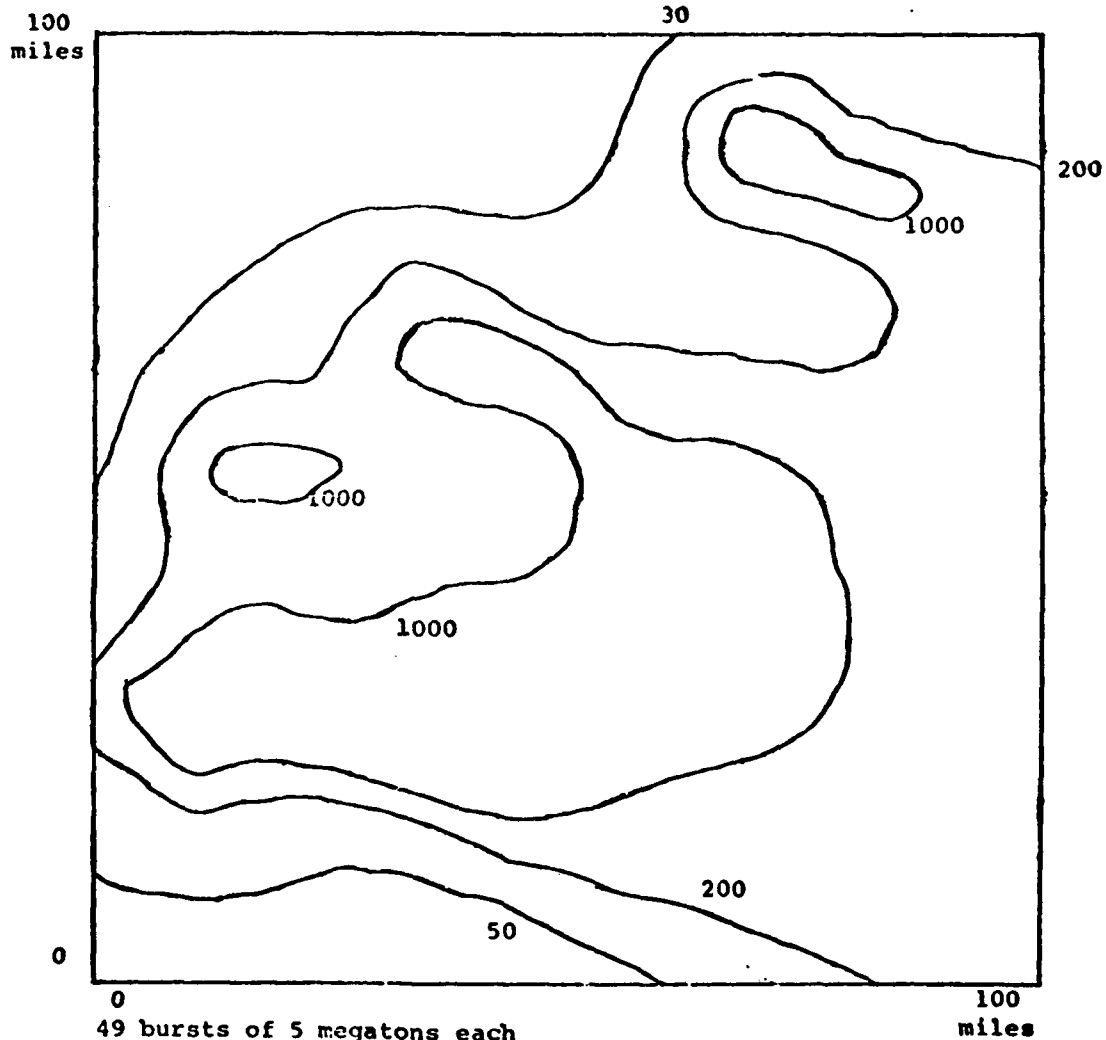

0  
 49 bursts of 5 megatons each  
 Central California, Winter season  
 Time H + 1 hour  
 Intensities in R/hr.

Figure IV-1. Fallout Pattern 1

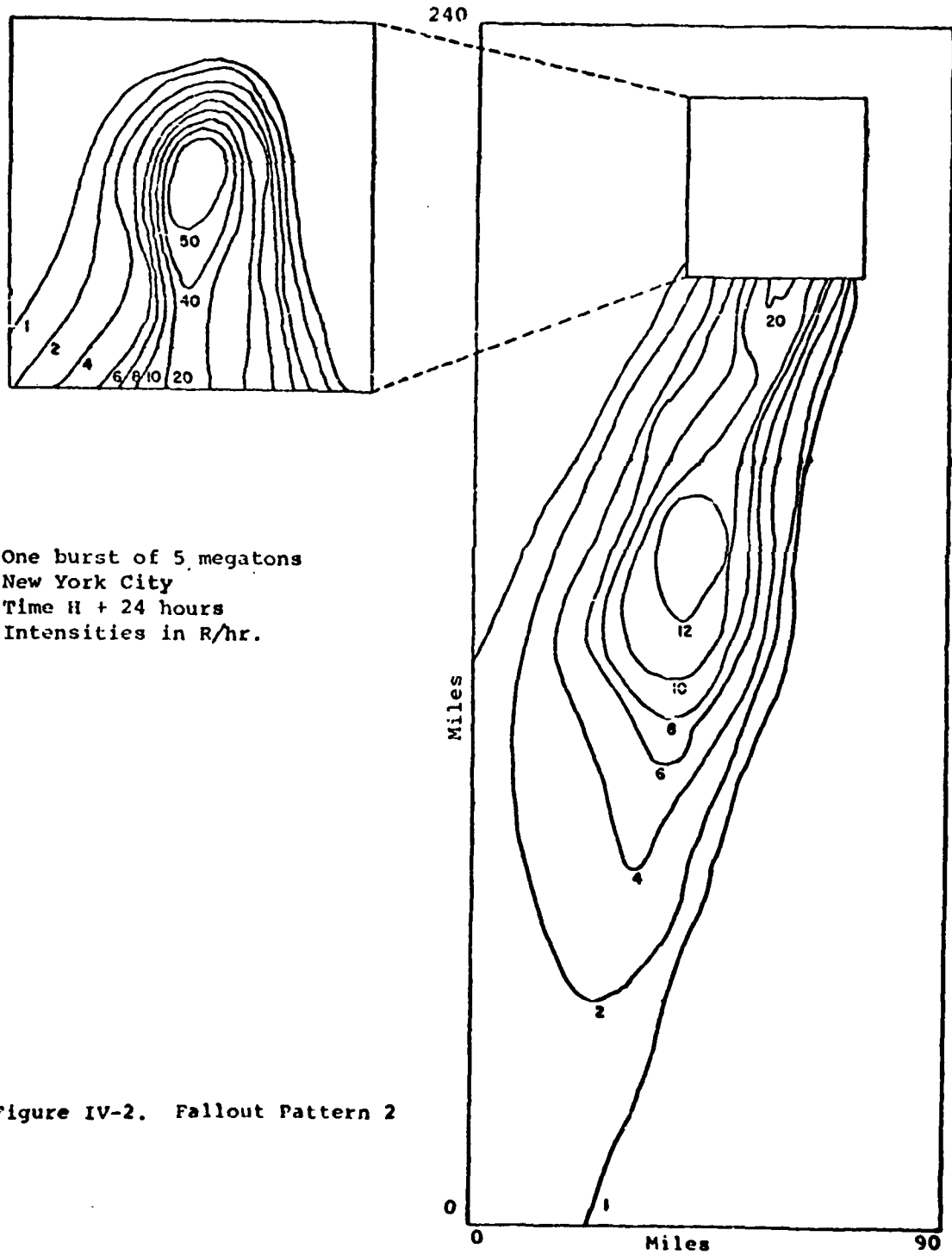

One burst of 5 megatons  
 New York City  
 Time H + 24 hours  
 Intensities in R/hr.

Figure IV-2. Fallout Pattern 2

is 0.0 to 95.0 R/hr. before introduction of small scale effects.

When the patterns are unmodified by small scale effects, they are designated by 1N and 2N, respectively. Two new patterns were obtained, designated 1S and 2S, respectively, by sampling from the distribution of small scale effects shown on figure IV-17 to obtain a value of  $(1 + \Delta W/W)$  by which the dose rate at each point of the pattern was multiplied.

Sensor spacings of 5, 10, 20, and 50 miles were used.

Two methods of obtaining the estimate  $\hat{W}(J,K)$  were used. They are the Mod I and Mod II methods described above.

Two values of the probability of malfunction at the sensor location were used: 0.1 and 0.01.

The distribution of sensor measurement errors is assumed to be normal, with a mean of zero. Standard deviations of zero (i.e. no measurement error), .075 and .15 were used. For example, with a standard deviation of .075 the measured intensity at a point is within  $\pm 7.5\%$  of the actual intensity at the point 68% of the time; within  $\pm 15\%$ , 95% of the time; and within  $\pm 22.5\%$ , 99.7% of the time. With a standard deviation of 0.15 each of the above ranges is multiplied by two.

Two sets of zone boundaries were used. For some simulation runs, the boundaries were 2,4,8,16,20,40,80,100,400, and 500 R/hr. These were selected from among the intensity reporting points during fallout build-up suggested in table XXVII of RADIOLOGICAL MONITORING: CONCEPTS AND SYSTEMS, SRI Project No. IMU-4021,

Stanford Research Institute. The selection was made because the computer program will accept at most ten boundaries, and because it was assumed that the system can report only intensities less than 1000 R/hr. The use of these zones was coupled with a sensor spacing of 50 miles, which is discussed in that same report.

For other sensor spacings the zone boundaries were 1, 10, 100, and 998.5 (the largest intensity which can be distinguished by the proposed system). Thus with these boundaries, an estimate is made of the relative frequency with which the intensity can be estimated within an order of magnitude.

### 2.3 Output

Output from a typical simulation run is illustrated in figure IV-3 which is a reproduction of the output from the printer associated with the RCA 301 computer, for which the simulation was programmed.

The first four lines of the print-out indicate the values of the parameters. For example, these results were obtained with a spacing of 50 miles, pattern 1N, estimation method Mod I, a probability of malfunction of 0.1, and standard deviation of the distribution of measurement errors of 0.075. Also indicated is the first number in each of the sequences of pseudo-random numbers used to determine (1) the points at which estimates are made, (2) the relative orientation of the fallout pattern with respect to the sensor network, (3) the measurement error, and (4) whether or not a sensor malfunctions.

Following the information concerning the inputs to the simulation, each line of the print-out gives the results of



computations concerning one point randomly selected from the area covered by the fallout pattern. The first point, as indicated by the first two columns, has coordinates (76,88) with respect to the "radiation data axes". The next two columns indicate that the nearest sensor has coordinates (83,68), also with respect to the "radiation data axes". With respect to the "sensor axes", where the coordinates are in units of the sensor spacing D, this sensor has the coordinates (2,2), as indicated in the column headed "Sensor ID". This column also indicates when a sensor is destroyed by blast by inserting the letter B in the Sensor ID. The letter M is inserted when a sensor malfunctions. When the measurement (obtained by applying the sample value of the measurement error\* to the actual intensity obtained from the fallout pattern) is either above or below the limits of the system, the letter U or L, respectively, is inserted and the appropriate limit is reported as the measured intensity.

The next column gives the sensor measurement which is used as the estimate  $\hat{W}(J,K)$ . A floating point notation is used. For the first point, for example, the measurement is 651R/hr. The next column gives the actual intensity at the point (76,88): 600R/hr. The next column gives the error  $E(J,K)$ , which for the point (76,88) is .085. The error is designated "Type 1" because the actual intensity is within the range of the system. The last column indicates that the point is estimated to lie in zone 11, which corresponds to intensities greater than 500R/hr. Since the actual intensity is in this range, the error  $X(J,K)$  indicated in the next to the last column, is zero.

\*The normal deviates were obtained by the following procedure: (4)

$$Y_1 = (-2 \ln X_1)^{1/2} \cos 2\pi X_2$$

$$Y_2 = (-2 \ln X_1)^{1/2} \sin 2\pi X_2$$

where  $X_1$  and  $X_2$  are independently and uniformly distributed on the interval (0,1) and  $Y_1$  and  $Y_2$  are independently and normally distributed with mean zero and unit variance.

An impression of the nature of the random variation of the orientation of fallout pattern to sensor network can be gained from figure IV - 4. A 100 x 100 grid square is shown which represents the area covered by the fallout pattern. Marked on the grid square are the positions of the sensors used to obtain the measurements for the first 15 points of the output in figure IV-3. The three different orientations are easily discerned.

The output illustrated in figure IV - 3 was stored on magnetic tape. Following a run with a given set of input parameters, the information on the tape was processed to form frequency distributions of  $E(J,K)$  for each type of error and of  $X(J,K)$  for each zone. The result of this computation is illustrated in figure IV - 5.

The first four lines of the print-out identify the tape on which the data were stored and the input parameters of the simulation run from which they were obtained. Next are listed frequency distributions of  $E(J,K)$  for each type of error. Actual frequencies, relative frequencies and cumulative relative frequencies are given. Similar distributions are given of  $X(J,K)$  for each zone. The boundaries of the class intervals used in these computations are listed with each distribution.

#### 2.4 Results

Figure IV - 6 shows the frequency distribution of the Type 1 error  $E(J,K)$  obtained with a sensor spacing of 20 miles, pattern 1 without small scale effects, and the Mod I method of obtaining  $\hat{W}(J,K)$ . The probability of malfunction was 0.1 and the standard deviation of the distribution of measurement errors was .075.

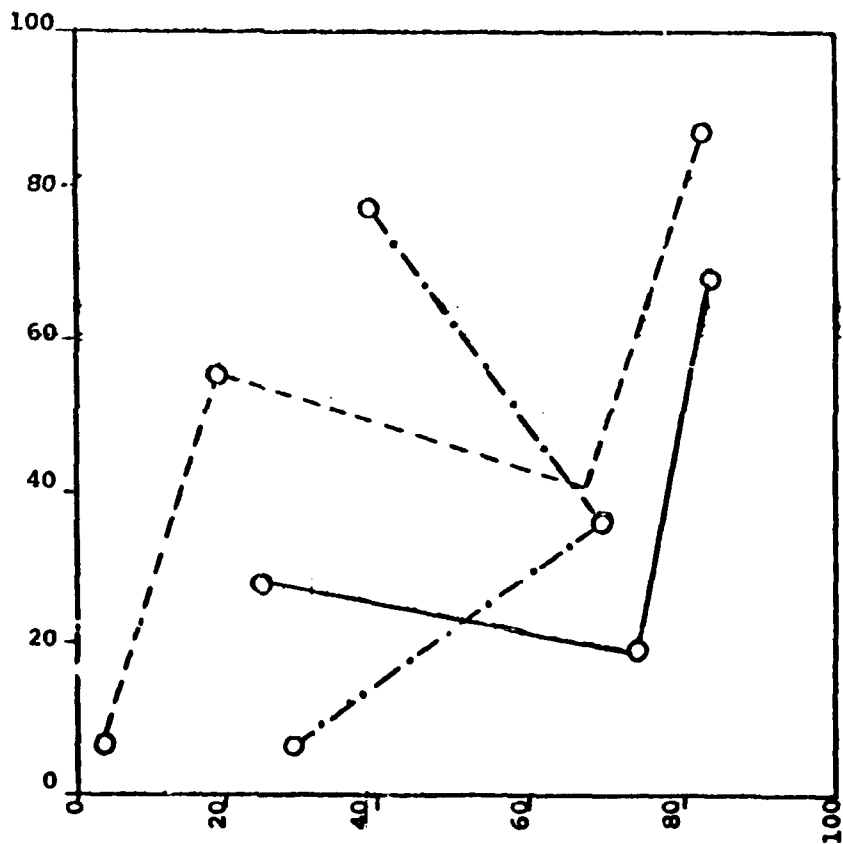

Figure IV -4. Three different orientations with respect to fallout pattern of sensor network with 50-mile spacing.





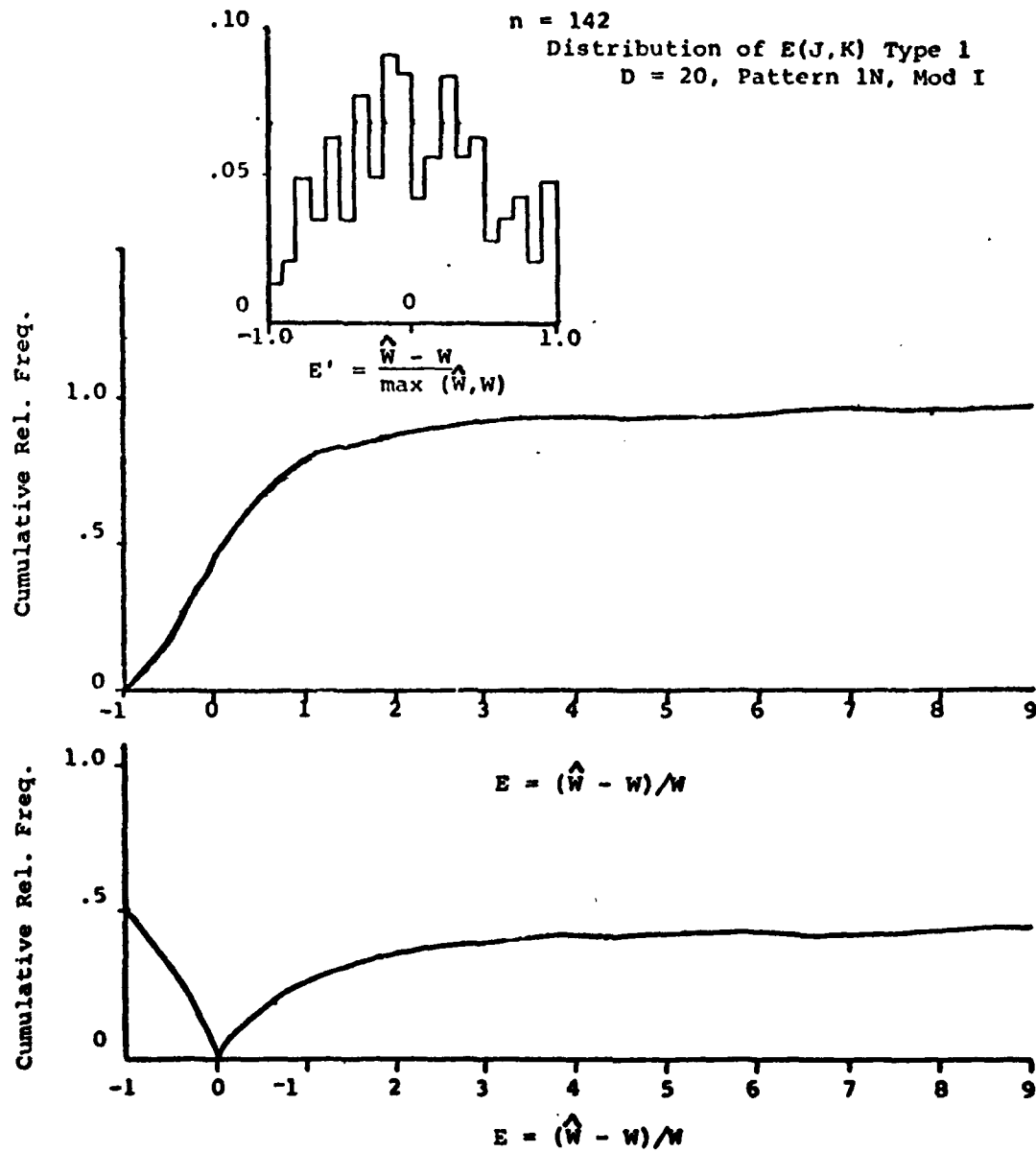

Figure IV-6. Error Frequency Distribution

The range of  $E(J,K)$  as defined in 2.1 above is  $-1$  to  $\infty$ . It is convenient in presenting these results to use

$$E'(J,K) = \frac{\hat{W} - W}{\text{Max}(W, \hat{W})}$$

which has the range  $-1$  to  $1$ . The histogram at the top of figure IV -6 shows the relative frequencies for twenty intervals of  $E'(J,K)$  equally spaced over the range. These results were obtained from a sample of 200 points, of which 142 had values of  $W(J,K)$  within the range of the system, i.e. type 1 errors. In the middle of figure 13 is shown the cumulative distribution of  $E(J,K)$ . Note that slightly more than half (.52) of the values are negative and that 95% are less than 9.0. The form of the cumulative distribution shown at the bottom of figure 13 makes it convenient to see what the relative frequency is of errors within a given range on either side of zero. For example, negative errors between -50% and zero occurred with a relative frequency of 34% and positive errors between zero and 100% occurred with a relative frequency of 30%.

Figure IV -7 shows the distribution of  $X(J,K)$  for the same set of parameters. There were only two instances of points assigned to Zone 1, corresponding to  $\hat{W}(J,K) < 1$  R/hr. In one of the cases the assignment was correct --i.e., the error  $X(J,K)$  was zero (indicated on the scale as being between  $-10^{-10}$  and  $10^{-10}$ ). In the other case there was an underestimation of the intensity with the difference between the actual intensity and 1 R/hr. being between  $-10^{-10}$  (actually zero) and  $-1$ . There were 37 instances of assignments to Zone 3, where  $\hat{W}(J,K)$  is between 10 and 100 R. Of these 65% of the assignments were correct. However, in 5% of the cases the intensity was

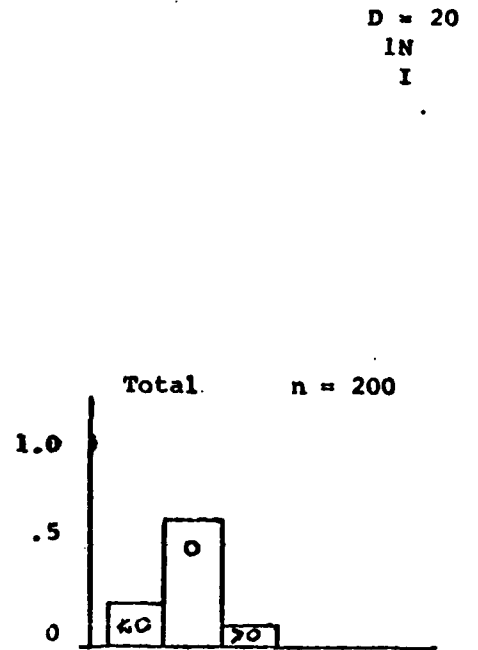
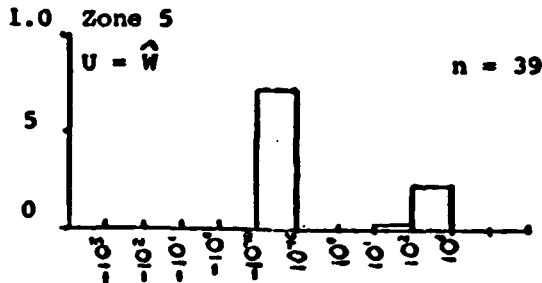
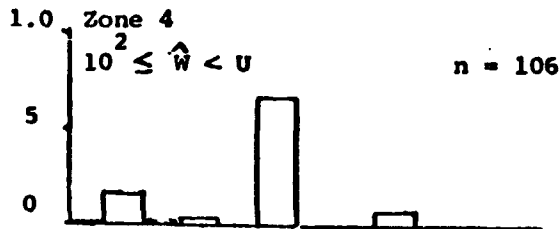
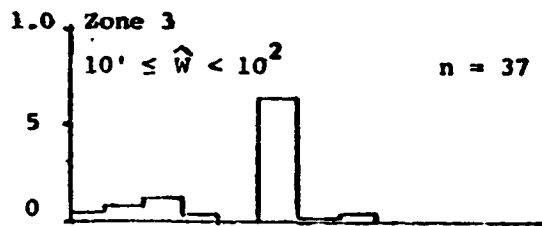
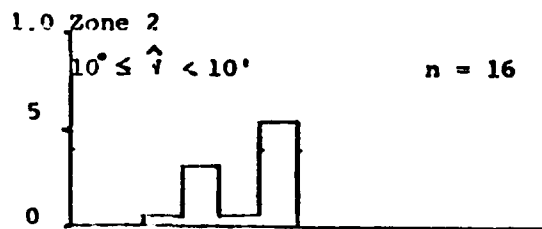
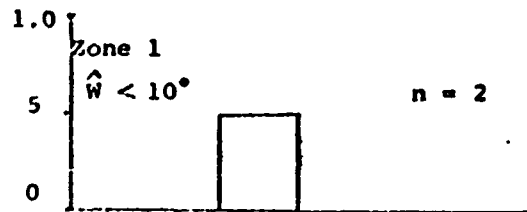

$U = 998.5$

Figure IV-7. Zone Error Frequencies

underestimated with the deviation being 1000 R or more. Summarizing the results for all zones, 68% of the assignments were correct. In 21% of the cases there was an underestimation and in 11% an overestimation.

The results of varying sensor spacing are summarized in figure IV -8. In the upper lefthand corner is shown the cumulative distributions of  $E'(J,K)$  Type 1 for spacings of 5, 10, 20, and 50 miles, using pattern 1N and method Mod I. Similar distributions are shown at the upper righthand corner for spacings of 20 and 50 miles and pattern 2N. Summaries of the distributions of  $X(J,K)$  for the same input parameters are shown at the bottom of figure 15. It should be noted that the zone boundaries for  $D=50$  were different from those for the other spacings.

These results are further summarized in figure IV -9 for pattern 1N. A curve of the relative frequency of  $X(J,K) = 0$  versus sensor spacing is drawn through the data points in table IV-1.

Table IV - 1

D	F(X = 0)	n
5	.86	100
10	.84	100
20	.68	200
20	.68	100
50	.44	200
50	.40	100

Pattern 1N  
Mod I

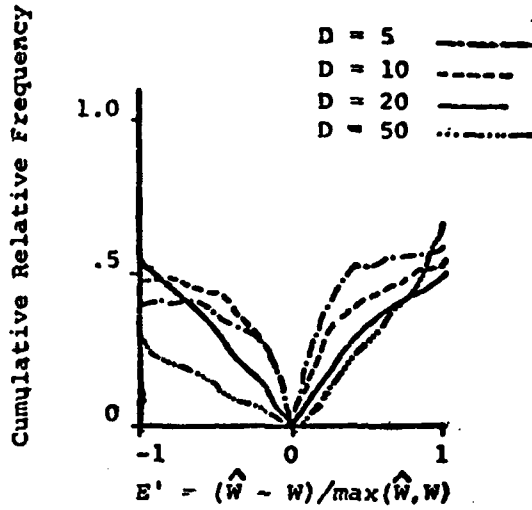

Pattern 1N  
Mod I

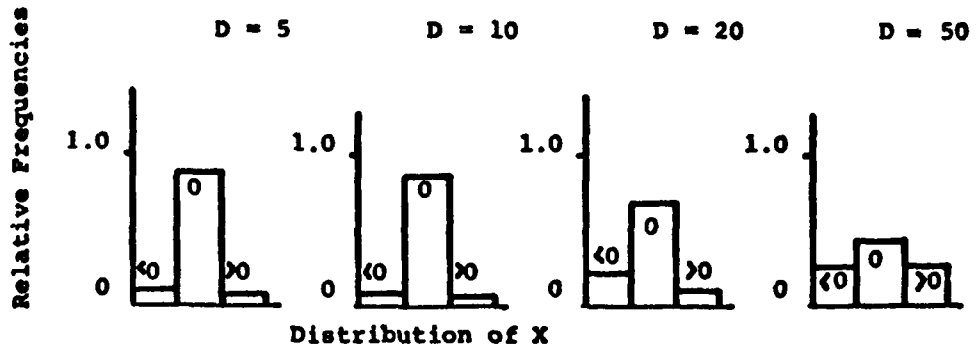

Pattern 1N

Figure IV-8A. Effect of Sensor Spacing

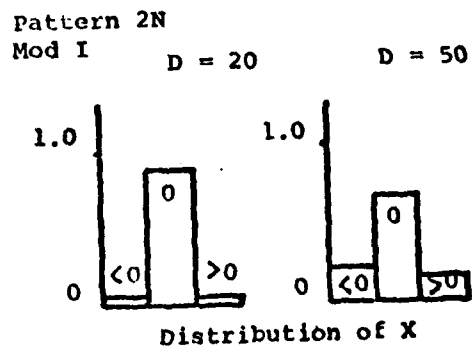
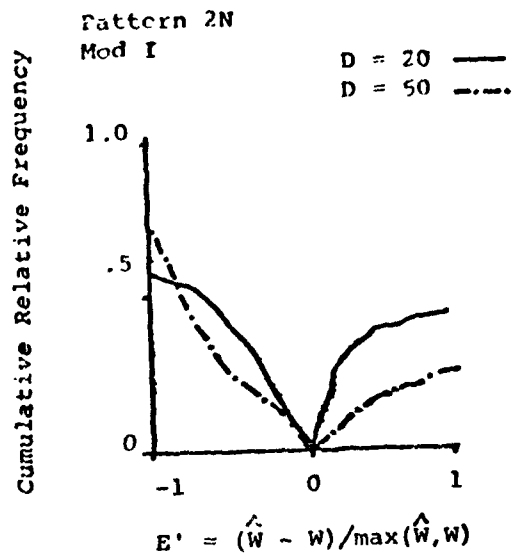

Figure IV-8B. Effect of Sensor Spacing, Pattern 2N

Curves are also shown (figure IV - 10) relating sensor spacing to the relative frequencies of E' between -0.5 and 0.5 (corresponding to  $\hat{W}/W$  between 1/2 and 2) and E' between -0.2 and 0.2 (corresponding to  $\hat{W}/W$  between 4/5 and 5/4). The data points are listed in table IV - 2.

Table IV-2. Confidence Factor versus Detector Spacing

D	$F(\frac{1}{2} < \frac{\hat{W}}{W} < 2)$	$F(\frac{4}{5} < \frac{\hat{W}}{W} < \frac{5}{4})$	n
5	.91	.65	75
10	.85	.51	75
20	.64	.27	142
	.64	.27	74
50	.48	.17	133
	.45	.16	69

Further discussion of the effect of sensor spacing is deferred to Section IV.6 when cost is also taken into account.

In order to assess with what degree of confidence statements about the relative frequency of certain outcomes of the simulation can be translated into statements about the probability of similar outcomes in the corresponding system in the real world, there are two factors to be taken into account. The first is the extent to which the finite sample of simulation calculations---e.g. computations of X(J,K) for 100 or 200 randomly selected points-- is representative of the population of all such simulation outcomes. The second is the extent to which the simulation is an adequate

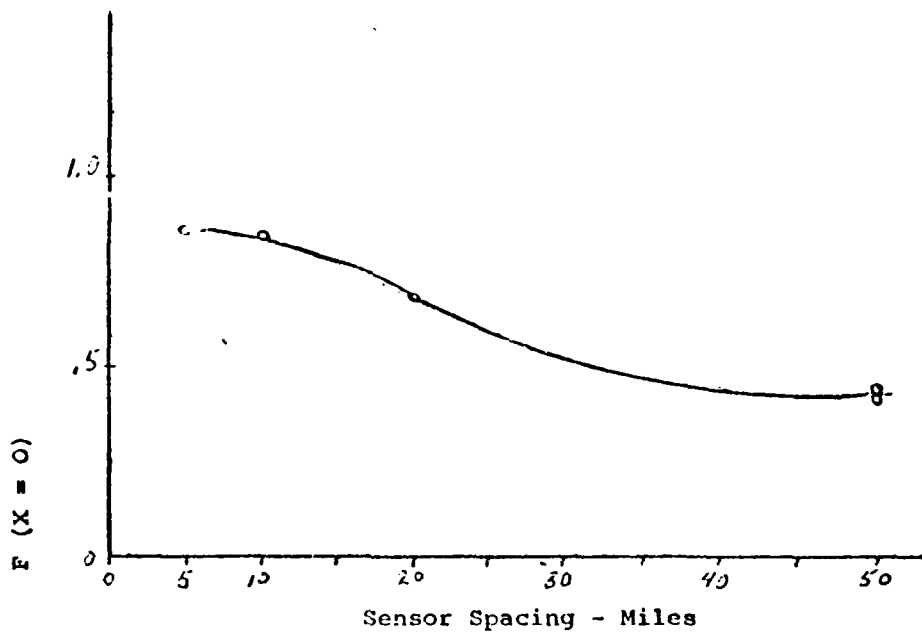

Figure IV-9. Accuracy versus Spacing (Zones)

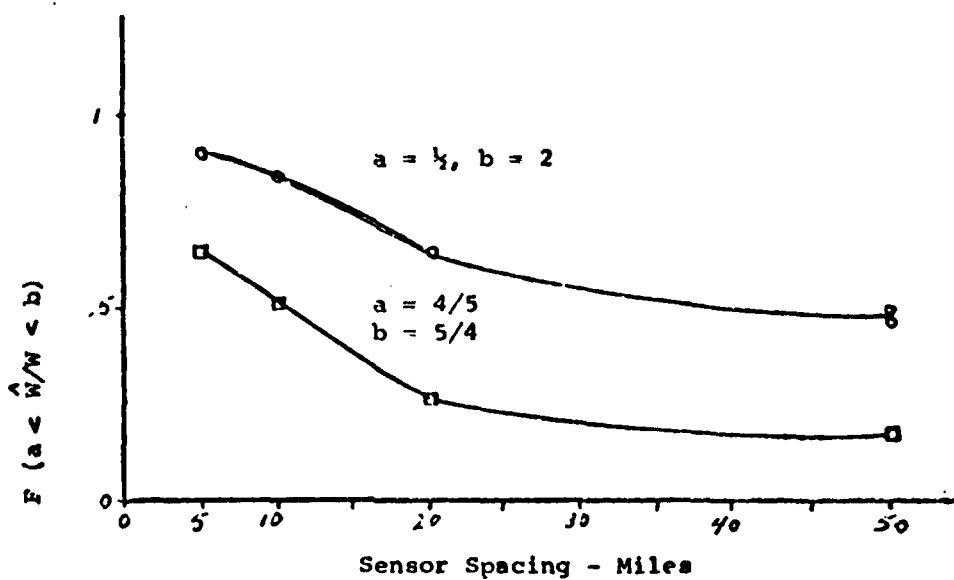

Figure IV-10. Accuracy Versus Spacing

representation of the real world system.

An estimate of the effect of sample size can be made from the results shown in table IV-1 and in figure IV - 11 which compare relative frequencies obtained from samples of 100 and 200 points respectively. From table IV - 1 note that with a sample of 100 points, the relative frequency of correct zone assignment, i.e.  $X = 0$ , for a spacing of 20 miles, is 0.68. For a sample of 200 points, the same relative frequency was obtained. For a spacing of 50 miles, the corresponding figures are 0.40 and 0.44. From figure IV - 11, we note that the relative frequencies of  $E'(J,K)$  Type 1 generally deviated by less than 5% as the sample size was approximately doubled, all other conditions remaining fixed. The curves at the upper righthand corner of figure IV - 11 show a greater deviation when results using a single orientation of the fallout pattern relative to the sensor network are compared with those where 40 different orientations were used. For all of the other results reported here the sampling scheme described earlier was used, i.e. for each 100 points, 20 different orientations were used representing random selection under the assumption that all possible orientations are equally likely. The same set of orientations was used and in general the same set of points \* for each set of parameters.

Lacking a real world system with which to experiment, there are no exact answers to the second question. It must

\*The correspondence of points is not exact since, for example, when the estimate  $W(J,K)$  was made from the measured intensity at the nearest sensor, the selected point is discarded if the nearest sensor is at a position not within the area covered by the fallout pattern data. For two different sensor spacings the sets of acceptable points are not necessarily identical.

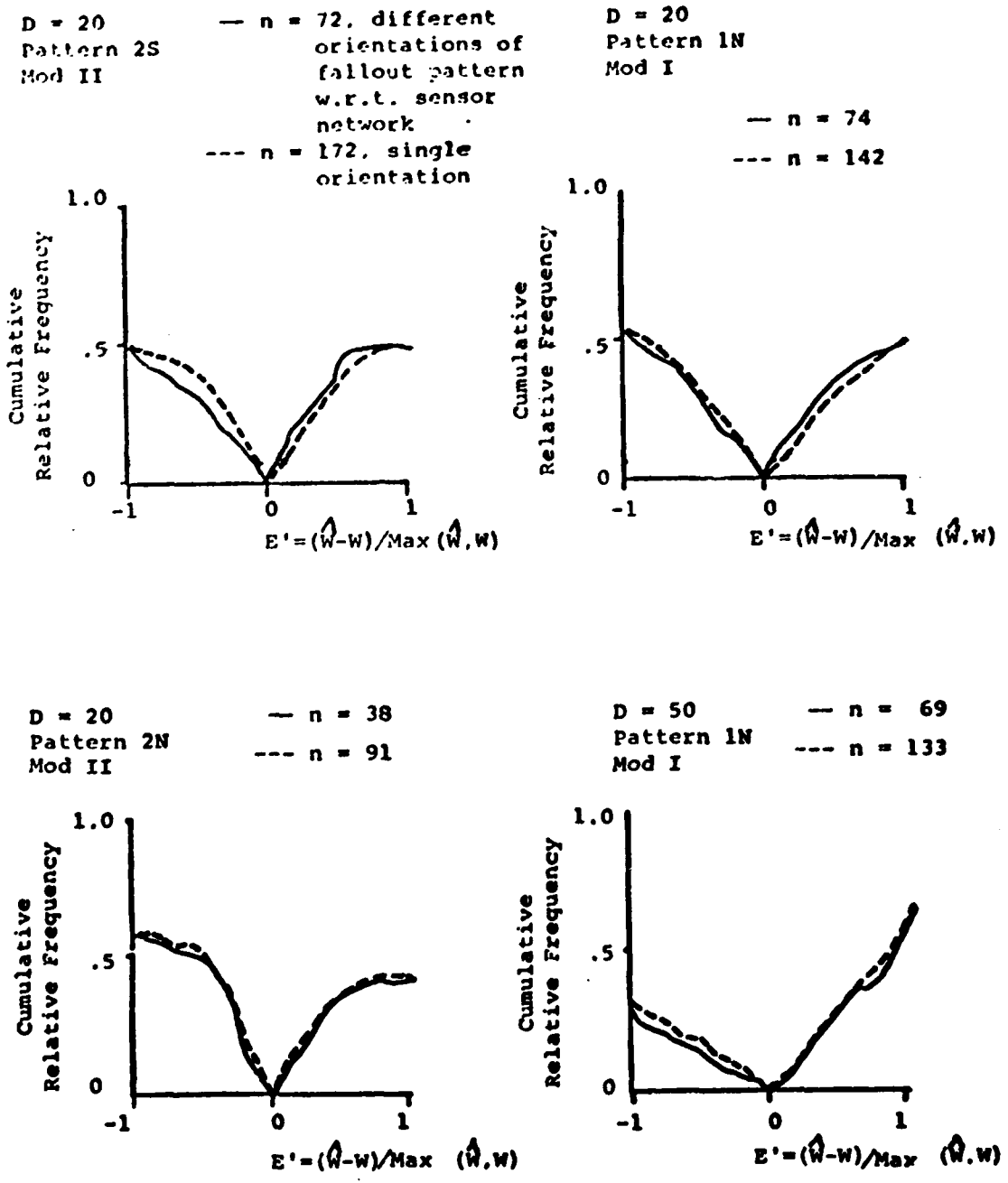

Figure IV-11. Effect of Sample Size

ultimately be left to the judgment of the user to assess the validity of the simulation as a model of the real world. This judgment can be aided, however, by an investigation of the sensitivity of the results to changes in the inputs to the simulation.

The most critical of these inputs is the nature of the fallout pattern. A comparison of the distributions of  $E'(J,K)$  Type 1, for patterns 1 and 2 is given in figure IV - 12. Errors appear to be systematically more likely to be small for pattern 2 than for pattern 1 except in the case of a 50 mile sensor spacing. In this case pattern 2 gives better results for negative errors (i.e. errors of underestimation of the intensity) but pattern 1 has the advantage, by approximately the same magnitude, with respect to positive errors (errors of overestimation). However, since errors of underestimation would almost certainly have more serious consequences than errors of overestimation it is probably fair to generalize all the cases pictured as favoring pattern 2. This is hardly surprising in view of the much smaller range of intensities and the greater regularity of this pattern. The influence of pattern regularity on this comparison is further borne out by noting that the advantage of pattern 2 is decreased when small scale effects are superimposed and the Mod II method of estimation is used.

Further evidence of the effect of the small scale perturbations is shown in figure IV - 13. Here it is noted that with pattern 1 the introduction of small scale effects modified the error distribution very slightly. There is an apparent small decrease in the probability of small errors, however the difference is generally within the range of the sampling error revealed in figure IV - 11. The same effect is noted with pattern 2 when

Pattern 1 ———  
 Pattern 2 - - -

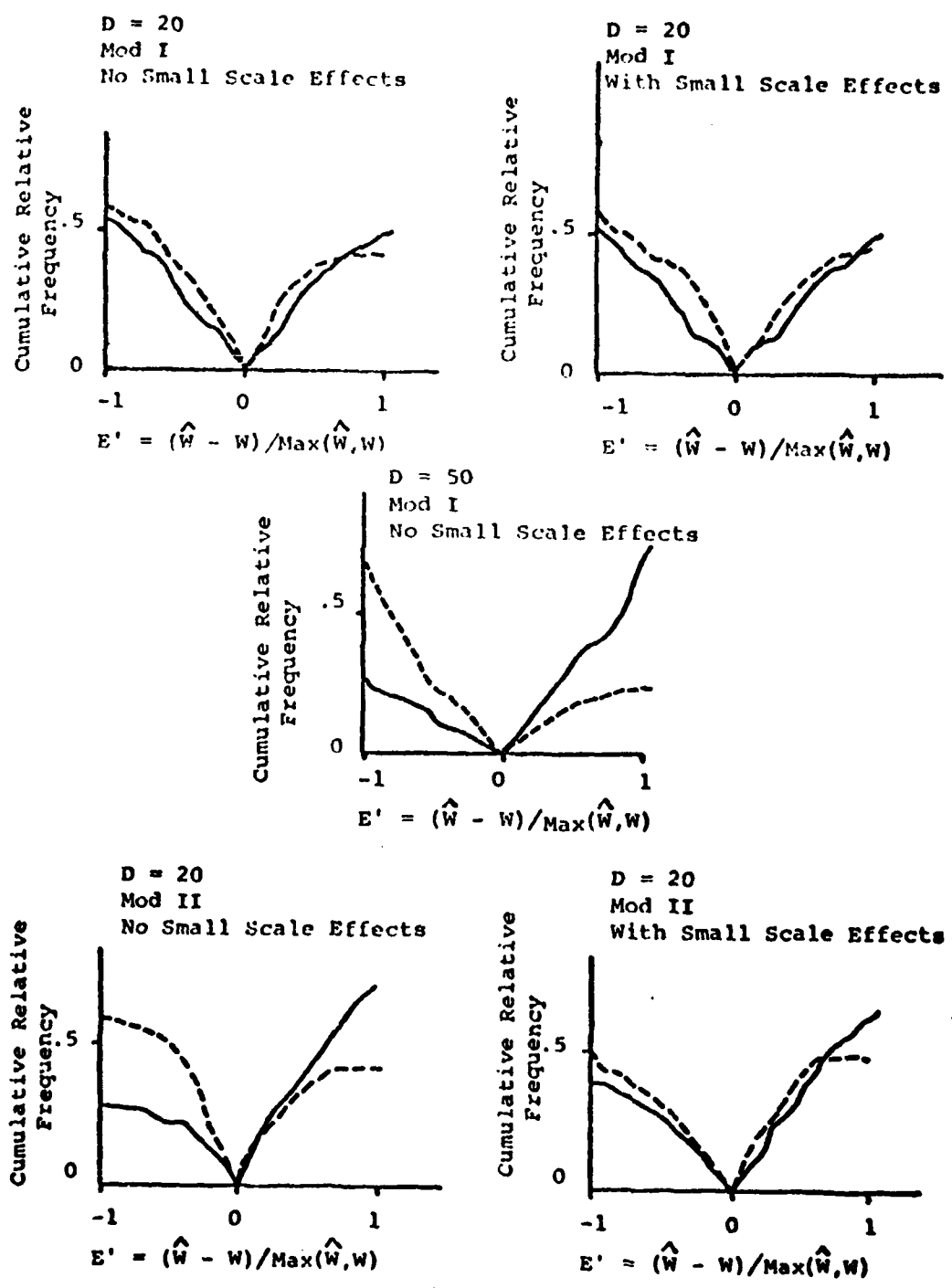

Figure IV-12. Effect of Fallout Pattern

No Small Scale Effects

————

With Small Scale Effects

- - - - -

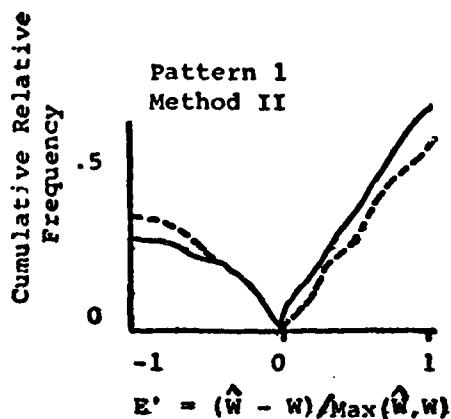
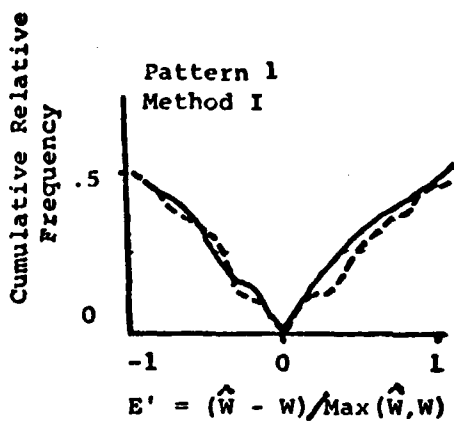

D = 20

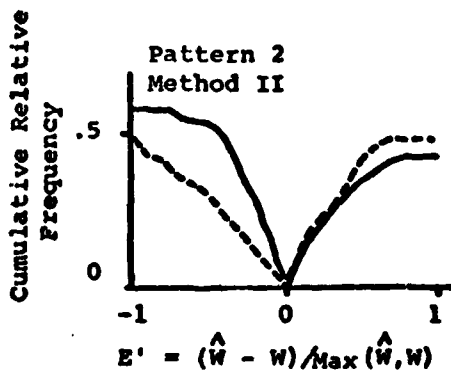
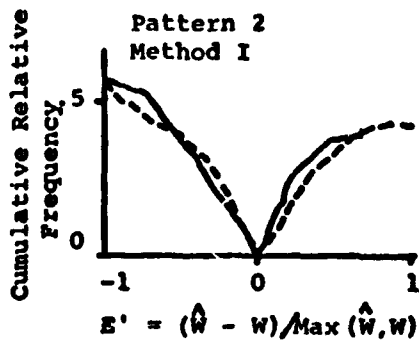

Figure IV-13. Effect of Small Scale Effects

the estimate is obtained from the nearest sensor. However, when the averaging procedure of Mod II is used, the introduction of small scale effects appears to materially decrease the probability of small errors, in particular errors of underestimation of the intensity.

The effect of the estimation procedure is shown in figure IV - 14. It might be expected that the use of the averaging procedure of Mod II would improve the estimate over that obtained from the single measurement of the nearest sensor (in all cases that this sensor is operative). However, figure IV - 14 shows that this is not always the case. In the case of a 20 mile spacing and pattern 1 there is no clear-cut advantage, though the use of Mod II does make large negative errors less likely than large positive ones, while with Mod I they are about equally likely.

Mod II does prove advantageous in two of the cases investigated: with a 20 mile spacing and pattern 2 with no small scale effects, and with a 5 mile spacing pattern 1, and no small scale effects. Thus for a 20 mile spacing the averaging procedure appears not to be advantageous if the irregularities of pattern 1 or of pattern 2 with small scale effects can be considered representative. The averaging procedure does become advantageous, however, as the spacing is decreased from 20 to 5 miles. Further runs would have to be made to determine for what spacing the advantage first appears.

There is a third curve shown for the case of  $D = 20$  and pattern 1S. As originally programmed the estimate for Mod II was made with less than 4 sensor measurements if one or more of the sensors surrounding a point was located outside the area

——— Mod I      - - - - - Mod II      - . - . - Mod II  
 (omitting border points)

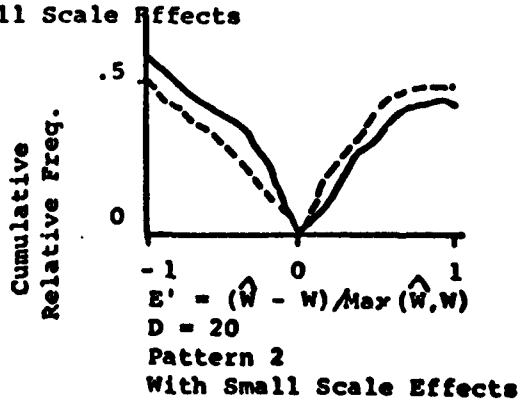
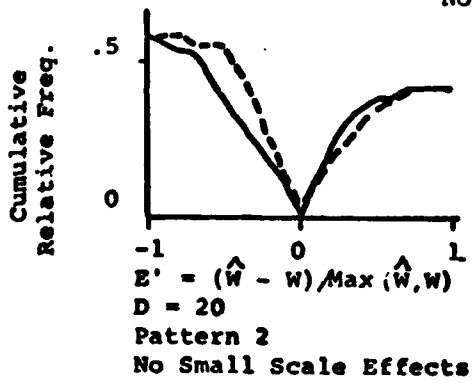
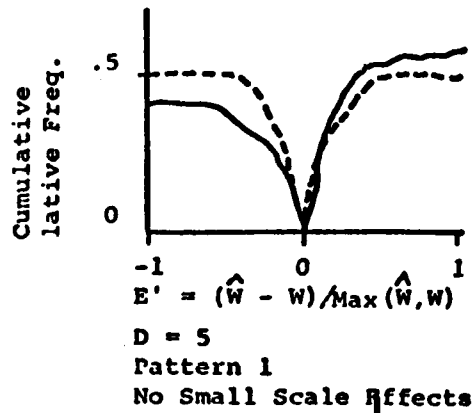
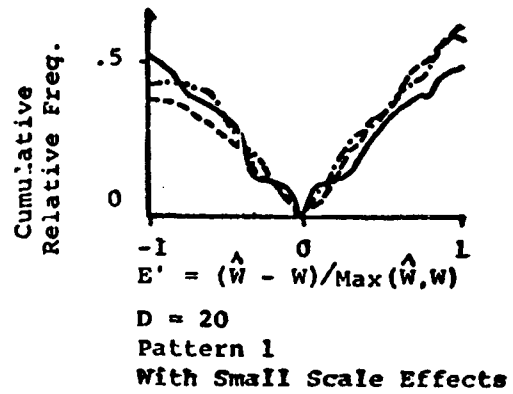
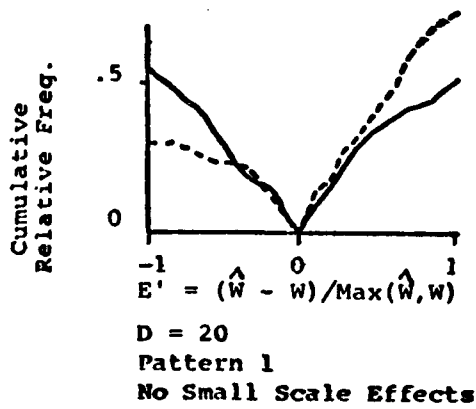

Figure IV-14. Effect of Estimation Method

covered by the fallout pattern. To determine whether this biased the results a run was made which deleted from the sample all points for which less than 4 surrounding sensors were covered by the pattern. No significant difference in the results is observed.

It should be noted that though not included here, it would be possible to extend this procedure to investigate the effect of boundaries on information accuracy in order to assess, for example, the value of making data from sensors in one region available to a neighboring region.

The effect of assumptions concerning the distribution of sensor measurement errors is illustrated in figure IV - 15. In all cases the mean of the distribution is zero. The standard deviation varies from zero (i.e. no measurement error) to 0.15. The effect on the relative frequency of small errors appears slight.

The effect of variation of the probability of malfunction is shown in figure IV - 16. If the probability of malfunction is reduced from 0.1 to 0.01 there appears to be a slight decrease in the errors of underestimation but no change in the errors of overestimation. These results were obtained with pattern 1N and the Mod I estimation procedure. While no runs were made to investigate the effect of malfunction probability with the Mod II procedure or with pattern 2, intuition suggests that the effect would be greatest for the more irregular pattern and when the procedure calls for using the nearest sensor, if operative.

D = 20  
 Pattern 1N  
 Mod I

$\sigma = 0$     - · - · -  
 $\sigma = .075$     ———  
 $\sigma = .150$     - - - -

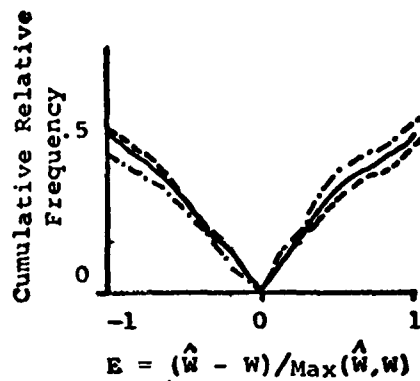

Figure IV-15. Effect of Measurement Error

D = 20  
 Pattern 1N  
 Mod I

P = .1    ———  
 P = .01    - - - -

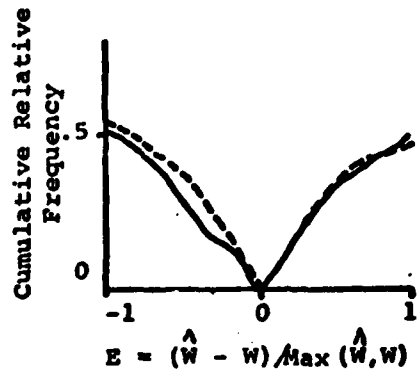

Figure IV-16. Effect of Malfunction Probability

### 3.0 SMALL SCALE EFFECTS

Small scale effects are the influences exerted upon the radiation intensity by local phenomena. The tendency of these small scale effects is to modify intensities so that they are not accurately represented by a single sensor reading in a given area. Because of this possibility, small scale effects had to be studied in some detail to determine how they would affect a radiological monitoring system.

The character of small scale effects, their influence, and methods of reducing their contribution were analyzed to determine:

(a) whether small scale effects would be so disruptive as to render ineffective a system of fixed sensors.

(b) whether the contribution of small scale effects to reported data could be reduced by acceptable techniques.

#### 3.1 Influence of Small Scale Effects

Small scale influences due to terrain, vegetation, buildings and local weather cause variations in the gamma radiation field intensity. These variations are termed small scale effects.

In the absence of small scale effects, the idealized radiation field intensity measured at a monitor point depends only upon the weapon characteristics overall meteorological conditions, soil composition height of burst and location of ground zero. The actual measured radiation field intensity is thought of as a result of small scale effects operating on this idealized field.

Small scale effects influence the gamma radiation field in two ways:

(a) They generally absorb gamma photons, thus lowering the field strength.

(b) They modify the radioactive fallout distribution which in turn modifies the gamma radiation field strength.

Variations in intensity due to small scale effects are partly predictable and partly random in amount. Predictable small scale effects are due to fixed small scale sources such as buildings, terrain and vegetation. Random small scale effects are due primarily to the interaction of local weather with structures and topography.

In order to determine whether small scale effects can be expected to cause the radiation monitoring system to be ineffective, the nature of specific small scale effects must be evaluated.

Structures, in general, will cause the redistribution of fallout, and absorb photons.

Buildings and other structures are composed of vertical and non-vertical surfaces. The non-vertical surfaces of essentially all structures may be considered as traps for fallout.

The general effect of buildings and structures is to decrease intensity.

Terrain, in general, reduces the field, as a result of both terrain geometry and surface roughness. Even though there is more surface available due to topographic features to receive fallout,

the fallout deposited per unit of terrain surface is decreased. Since the total amount of fallout remains constant, and the folds in the terrain effectively increase the shielding, the field strength is generally reduced.

There are some locations where the terrain may amplify the field strength. For instance, a measurement might be made at the bottom of a large slope of smooth rock. The fallout deposited on the rock surface will slip to the bottom of the slope, thus increasing the intensity measured there.

Standing surface water generally acts as an absorber of gamma radiation. The effectiveness of the absorber depends on both the depth of the water and the percentage of incident fallout that sinks into the water. Fallout is generally composed of insoluble oxides. Thus the mechanical behavior of fallout in water is essentially the same as that of silt. Consequently fallout will not remain on the top of flowing water. (5)

Wind erosion of fallout on soil does not occur with any significance after the first day of deposition in dry climates. The erosion of fallout on surfaces with rms (root-mean-square) roughness of greater than 0.25 inches is not significant. Fallout deposited on paved surfaces will be eroded until it reaches gutters, curbs, storm drains, etc. (6) (7)

Light rain tends to decontaminate vertical surfaces and create additional gamma absorber (as standing water).

Heavy rain will tend to cause general decontamination. Decontamination effectiveness will be greatest in urban areas (where general surface roughness is low and drainage systems provide for continuous removal of effluent) and least in rural areas on flat terrain.

An accumulation of solid precipitation may be treated as an increase in rms surface roughness, yielding a lesser field strength.

Figure IV-17 quantitatively summarizes one aspect of small scale effects. It shows the degree to which field strength may be disrupted by small scale effects for monitor points located in suburban residential areas. The ratio of perturbed to unperturbed field strength is shown against the relative frequency with which each ratio would be expected to occur. A very peaked distribution (i.e. having a small variance) would be optimal.

The histogram is constructed from an analysis of the data presented in Radiological Recovery of Land Target Components, Owen, W. L. and Sartor, J. D., NRDL, 1962. The multiple peaks in the plot are believed to have resulted from combining data from several different types of monitor points into one histogram (sensor between two buildings, buildings on one side only, etc.). It is expected that individual histograms for each type of monitor point would show less variance than indicated in this figure.

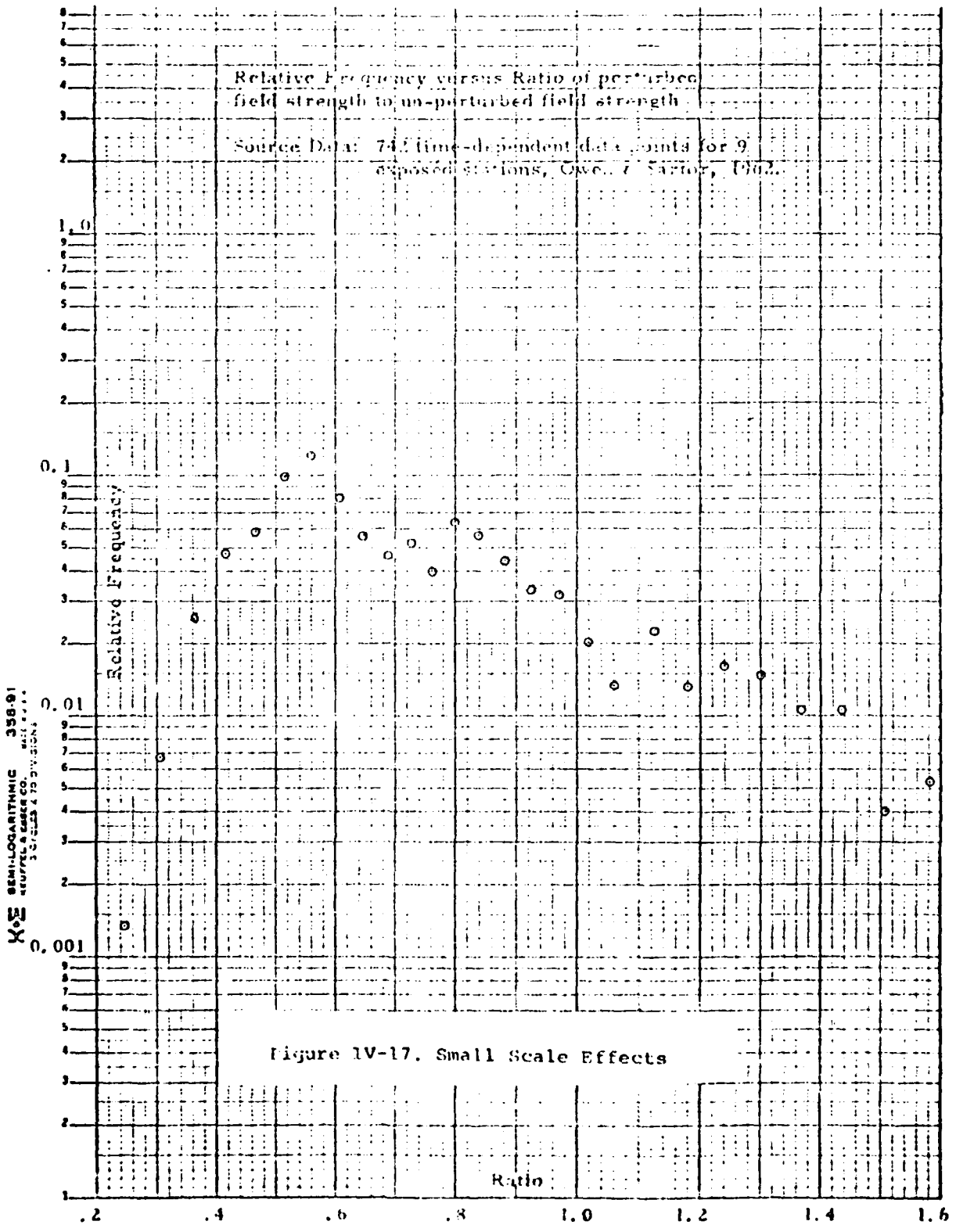

Figure IV-17. Small Scale Effects

K&E SEMI-LOGARITHMIC 358-91  
 HEUFEL & CASER CO. BELL 4-1-4  
 3 CIRCLES 4 TO DIVISION

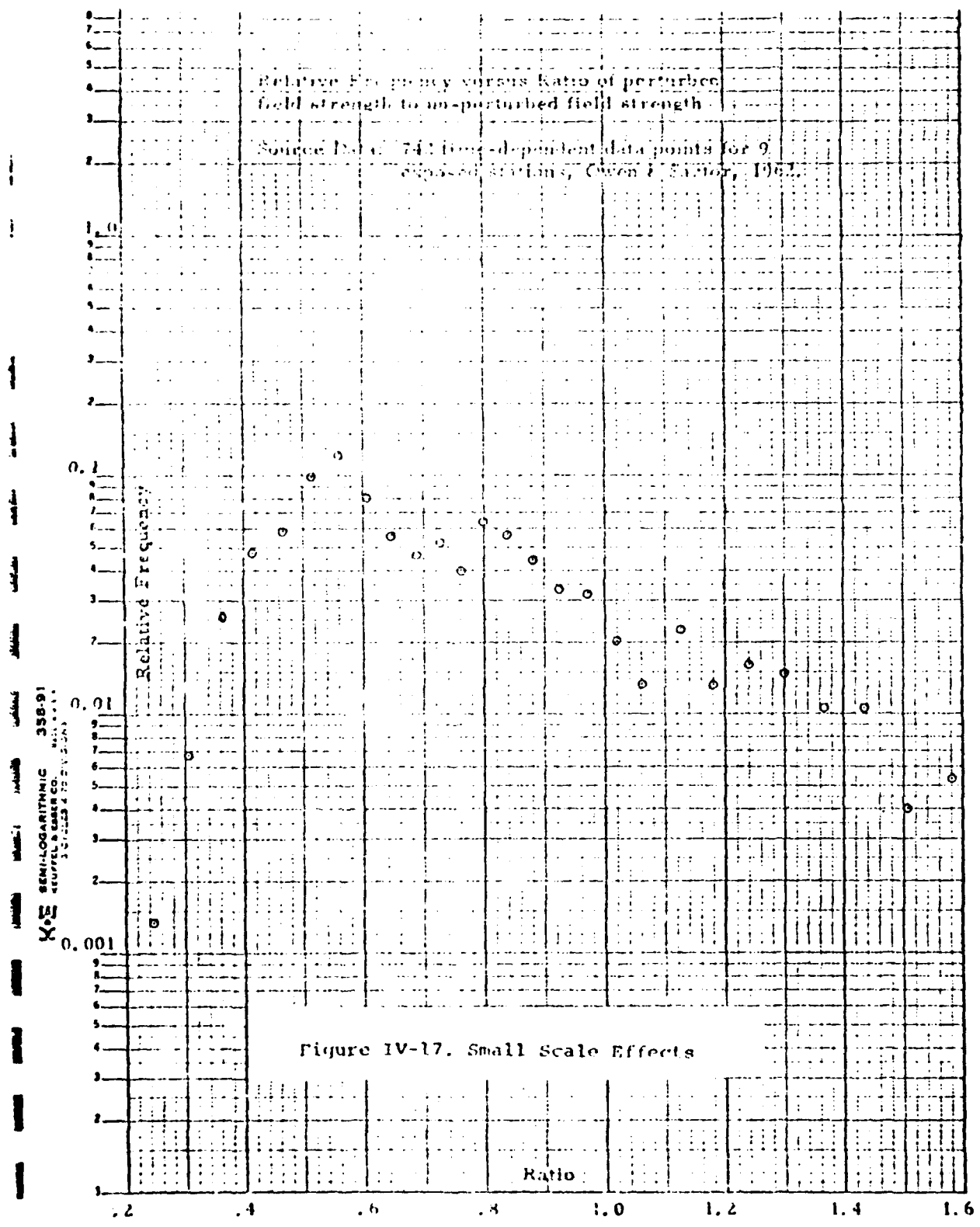

Figure IV-17. Small Scale Effects

K&E SEMI-LOGARITHMIC 358-91  
 KRUPP & BASS CO. 1961  
 107-113 47th St. N.Y.C.

To determine to what extent small scale effects with this distribution would degrade accuracy of a monitoring system, this histogram was used in the simulation reported in Section IV.2. The same calculation was made with and without small scale effects. Results indicated that accuracy would remain within acceptable limits.

### 3.2 Siting of Sensors

Sensors will report readings which are representative of large scale effects to the extent that they are not perturbed by small scale effects. Care given to siting of individual sensors will therefore improve the accuracy of the system by improving the quality of the basic input. Readings can be improved by selecting optimal sites, adjusting sensors to reflect local conditions, or adjusting readings to reflect local conditions.

Perturbations of the intensity field are due to redistribution of fallout and the absorption of gamma photons. The redistribution occurs over approximately the area of the small scale source involved. The desirable detector site is a flat circular area covered with grass with the detector installed 3 feet above the center.

If the area is large enough, small scale effects would be limited to surface roughness, and even the effect of this roughness may be estimated. Influence of the radius of the area on accuracy is explored in Appendix C. A radius of 600 ft. is desirable.

Ideal detection sites will be difficult to find in cities, because of land use. Where ideal sites cannot be found, influence of small scale sources on sensor readings may be reduced by increasing the sensor height.

	Detector Height, Feet	
	3	30
Example I: Radius of Perturbed Fallout Area - 18 feet		
(a) Fallout Doubled in Perturbed Area	1.32	1.05
(b) Fallout Eliminated in Perturbed Area	.68	.95
Example II: Radius of Perturbed Fallout Area - 69 feet		
(a) Fallout Doubled in Perturbed Area	1.56	1.30
(b) Fallout Eliminated in Perturbed Area	.44	.70

Figure IV-18. Effects of Perturbations and Sensor Height

Figure IV-18 shows the estimated effect of specific perturbations in fallout deposition on the intensities at 3 feet and at 30 feet. For each height, a homogeneous fallout distribution which produced an intensity of 1 unit was first assumed. Then the intensities resulting from doubling, and from eliminating, fallout in first an 18 ft. and second a 69 ft. circle, were computed. Computations were based on the analysis in Appendix C. Observe that each specified perturbation produces a smaller change (from unity) in the 30 foot intensities than in the 3 foot intensities.

Accordingly, when ideal sites are not available, the following placement measures are recommended:

- (a) Place the detector at a height of 30 feet (as on a telephone pole).
- (b) Place the detector so that the small scale sources are disposed as symmetrically (with respect to azimuth) as possible.
- (c) Estimate the probable factor which small scale sources within several hundred feet will introduce by means of a computer calculation, as described in Section VI-3.

- (d) Compensate detector output for the effect of 30' versus 3' height. The factor to be applied to the 30' readings is estimated to be 1.7. Compensate also for the factor derived in step c.

Compensating factors preferably would be introduced at the sensor location if local use will be made of the readings. Alternatively the factors may be applied in the computer calculations at the Regional and National Centers.

### 3.3 Special Detector Design for Further Investigation

A further suggestion for control of small scale influences on sensor readings was made late in the study. Though it is considered promising, and is documented below, it was not developed to the point where it can be recommended.

The idealized gamma radiation field at any monitor point is a homogeneous distribution of gamma photon flux which has no noticeable horizontal directional features. The actual gamma radiation field generally has directional features due to small scale effects. All gamma radiation fields have two components of photon flux:

(a) direct flux - composed of photons which have not been influenced by the environment since their liberation from the fallout particles, hence they have travelled in straight lines.

(b) scattered flux - composed of photons which have experienced a change in direction of propagation through reaction with the environment.

Comparing idealized field flux with the actual flux shows that in general:

(a) Small scale effects reduce the total gamma radiation field flux.

(b) Small scale effects reduce the direct flux more than the scattered flux.

(c) The scattered flux of the actual gamma radiation field is less directional than the direct flux. This suggests that the influence of small scale effects on a detector can be decreased by eliminating the direct flux from the sensitive element by selective shielding at the detector. This shielding might consist of approximately a hemisphere (as modified by the local horizon) of lead underneath the detector. Compensation must be made for the substantial reduction in total flux. A thin polished cone (with negligible shielding value) would be used above the detector to prevent contamination. Further study of this idea is recommended.

#### 3.4 Determinations

Small scale sources modify the gamma radiation field intensity in two ways: (1) They absorb gamma radiation (2) They alter the fallout distribution. Usually this results in a reduction in field intensity. At any given monitor point the small scale effects are not completely predictable. The unpredictable effects are not so disruptive as to make a fixed monitoring system ineffective.

Small scale effects can be reduced at monitoring points by selective placement, elevation, and compensation of detectors.

#### 4.0 SELECTED SYSTEMS AND OPERATIONAL DOCTRINE

The two most promising system concepts were given detailed consideration. These are the Shelter-Based System and the Automatic System. Their elements were discussed in Section III. Because the higher echelon functioning of the two systems is similar, they could be combined into a hybrid system.

##### 4.1 The Shelter-Based System

This system relies on human operators for data monitoring and data entry into the system. The system is geared for hourly collection of data. A human operator at the shelter monitors the instrument reading which he then transmits by shelter transceiver or telephone to the Relay Point where another person enters it into switches on the Relay Panel. Readings from other points and from the Relay Point itself are entered also (a total of 7 three digit readings). An entry of 000 means the sensor reading is less than  $1/2$  R/hr. An entry of 001 means the reading is between  $1/2$  and  $1\ 1/2$  R/hr. and so on. An entry of 998 means that 998 is the nearest integer to the reading, and an entry of 999 means that the reading was greater than  $998\ 1/2$  R/hr. (and possibly off-scale).

Relay Point shelters report in turn to designated weather observation stations. On the average 5 relay shelters will report to an observation station by means of low speed teletype links. At the weather observation station paper tapes containing the radiological data will be perforated in a predetermined sequence. The radiological data collection and transmission to the Weather observation stations will proceed independently of the Weather data collection. It is necessary, however, to have the radiological data at the Weather station on time for

TABLE IV-3. SUMMARY OF COMMUNICATIONS DELAYS

n	x	T	T <sup>I</sup>	T <sup>II</sup>	T <sup>III</sup>
1	0.53	8.85	1.33	1	0.85
10	4.1	68.6	10.3	8	6.6
20	8.1	135.0	20.3	16	13
100	40	666.0	100.2	76	64

n - number of sensors reporting to a relay point.

x - time to collect data at an interchange center in minutes.

T - time to transmit all radiological data to the National Center over one single 100 word-per-minute circuit, in minutes.

T<sup>I</sup> - time to transmit all radiological data to the National Center over one high speed, 1000 word-per-minute circuit, in minutes.

T<sup>II</sup> - time to transmit radiological data to the National Center over two high speed circuits, in minutes.

T<sup>III</sup> - time to transmit all radiological data to the National Center over three high speed circuits, in minutes.

At Regional Headquarters the data would be entered into a computer, and the processing described in Section III.5, performed. Zone boundaries and histograms would be plotted by means of a plotter capable of drawing lines as well as plotting points. Projection and reproduction equipment would be used to make the information available to the persons there. The National Center also would receive the data for processing and display.

Emphasis in the processing and use of data is at the Regional Headquarters level. Reasons for recommending this level are:

1. The problem is simplified by dividing it into eight parts.

More attention may be received by each area.

2. Only part of the nation is dependent on the survival of each Regional Headquarters.
3. Communication of instructions from National to Regional Headquarters is reduced. (In many cases instructions from National would be routed by way of Regional Headquarters.)

The National Center might serve as back-up to a Regional Headquarters which is not in operation, of course, even though that Region might not receive the full attention it would receive from its own Headquarters if that were operating.

At the regional level, the scope of activity, planning, and decision-making is determined and defined by the responsibilities assigned to the region. At the National level, however, this scope covers the entire resources and population of the United States. At the National level the required interface is made with other military and civilian command and control systems to insure an overall integrated deployment of military and non-military resources for the successful conduct of operations.

It is not desirable, on the other hand, to place the main burden of this system at State level. Uniformity of implementation and operation is likely to be achieved only if Federal control is substantially maintained.

Conclusions, instructions, and recommendations would be transmitted from Regional Headquarters to lower headquarters by means of message and verbal communications used for normal Civil Defense work.

## 4.2 The Automatic System

The characteristics of this system are its high degree of automation and ability to operate unattended and continuously under various conditions. The system is designed for hourly collection of radiation data on a national scale, integration of radiation and weather data, and automatic transmission of the composite data to specified destinations. The system is flexible enough to permit wide variations in input sources and destinations. In addition, the system permits data exchange on a national scale.

Automatic sensor-transmitting units are used in this system. Each unit will consist of a radiation sensor, a radio receiver, a transmitter, an analog to digital converter, and a power source. The transmitter will be turned on by a command from the relay point. The details of this unit are discussed in the section on Element Considerations.

The communications link from the sensor to the relay point is by means of radio (or in some cases, land line). The relay point would be the location of the AMOS unit. The sensors are activated selectively and in a predetermined sequence by commands generated at the location of the AMOS unit. This is achieved by means of a timer synchronized with the communications system at the AMOS. This keeps power consumption at a minimum and the life of the power source at the sensor is therefore lengthened.

In the radio communication reporting system it becomes necessary to sequence the transmission of data from each sensor. The sequence must be such that interference at the receiving station is eliminated. The large number of sensors in the high density areas of the system make it necessary to use an interrogation sequence which activates the sensors and then initiates the transmission at a time when the reading has become stabilized.

There are many variables affecting the assignment of specific radio frequencies for the proposed OCD sensor reporting system. The full effect of the variables can only be determined by local measurements during the implementation of the system. However, the following discussion of assignments will show that the total frequency spectrum necessary to operate the system will be relatively small. The proposed system operates by the reflection of the transmitted energy from the D layer of the ionosphere, and the slant wire antennas will be angled relative to the vertical so that the mean energy path reflected from the D layer will be focused at the receiver of each unit. The mean path will be determined for twenty four hour a day, 365 day a year operation. The actual value of the height of the D layer varies from day to night and also as a function of the time of year. It is also noted that interferences with other units may result from energy reflections from the E and  $F_1$  and  $F_2$  layers of the ionosphere. The proposed system, operating at approximately 2 megacycles, provides the shortest distances for the various reflected paths. As the frequency of transmission increases, the altitude of the corresponding reflective layer of the ionosphere also increases. Therefore, the choice of 2 megacycles limits the effective distance for possible interference. Use of the typical altitudes of the various layers: D, 70 km or 44 miles; E, 100 km or 62 miles;

$F_1$ , 200 km or 124 miles; and  $F_2$ , 300 km or 186 miles shows that the probable area of interference from any specific transmitter is in the order of 5 times the distance from the transmitter to the focus point receiver. This calculation includes the second or third bounce for the reflection from the D layer and also the first bounce from the E and F layers. The calculations assume a smooth earth and uniform magnetic field. As a result of these approximations, a specific position in the operational system may deviate from these figures.

In the case of a distance interference factor of 5 times the focus distance the number of possible interfering signals is shown in figure IV-19. In this figure it is assumed that relay stations are spaced about fifty miles apart and that sensors are spaced twenty miles apart. In the figure there are nineteen relay stations receiving data from six remote sensors each, or a total of one hundred fourteen transmitting sensors within the distance of possible interference. We do not eliminate any sensor as a function of the directionality of the transmitting antenna. This

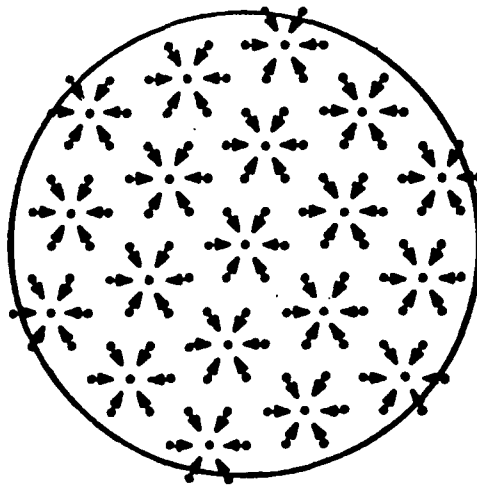

Figure IV-19. Transmission Interference Diagram

factor has been reserved as an additional safety factor, assuring that the transmitters do not interfere with each other.

In assigning specific frequencies for the transmitters it will be assumed that each sensor in a single cell requires an individual frequency and that frequencies can be duplicated between cells both within and without the interference circle through time phasing. In the proposed radio link, transmission rates as low as 4 bits/second for each transmitter are permissible. This figure is based on a data requirement of three decimal digits from each sensor and a two minute maximum time permissible for each relay station to collect its maximum number of remote outputs (when the sensors are spaced at six miles). The system can, however, operate at a much higher data rate, e.g. using 50 millisecond pulses. The use of a fifty millisecond tone pulse to indicate zero or one provides integration times sufficiently long for the receiver band pass requirements to be less than 100 cycles. A skirt of 200 cycles on either side of the 100 cycle band pass would permit assignment of frequencies spaced at  $\frac{1}{2}$  kc intervals with a safety margin. The ability to provide crystal controlled frequencies in the order of 1 part in  $10^7$  is a current state of the art technique, and  $\frac{1}{2}$  kc crystal separation is possible. For purposes of conservative estimation, we will assume that frequencies are assigned in 1 kc intervals. For the specific area chosen in the example, the entire area of possible interference contains 114 sensors and an assignment of an individual frequency for each sensor would require 114 kc of bandwidth, or that portion of the spectrum from 2,000 kc to 2,114 kc.

Even though a relatively small portion of the frequency spectrum would be required for a typical interference area, two additional techniques are available which will further reduce the amount of

frequency spectrum necessary to provide interference-free transmission from all of the remote sensors. The first technique is to time share and stagger the specific frequencies assigned. In the case of the example in figure IV-19 let a specific relay station be called Cell 1, and any two others be assigned numbers 2 and 3. Then, in each cell number the remote sensors 1 through 6 and identify a specific sensor by its cell and sensor number e.g. 1-2, 2-3 etc. In this example let all sensors numbered 1 have their receivers crystal controlled at 2001 kc. The relay stations are turned on sequentially by the APULS control, and therefore at any specific time only one relay station transceiver is operative. The relay interrogates sensor 1 by transmitting a command on 2001 kc. This signal, in this example, is received at all 19 number 1 sensor positions, and all 19 sensors start to operate. In assigning frequencies for the sensor transmission, let sensor 1-1 use 2002, sensor 2-1, 2102, sensor 3-1 2008, etc. The receiver at each relay station is crystal controlled to match only its own set of sensors. Therefore, even though all 19 sensor number 1 positions are transmitting, only the correct sensor number 1 information passes the crystal at the relay receiver and the proper message is received. Using this method of frequency assignment, it is possible to assign the same frequency to many sensors and the number of channels necessary reduces from 114 to about 24. In this technique, staggering of the receiver crystals will not reduce the number of sensors which are turned on. In the case being discussed it is assumed that all sensors within the interference area receive the signal so that a sensor in each cell would be responding to the interrogation signal.

A second technique available to reduce the number of channels necessary, and also the number of sensors responding to each interrogation, is that of interrogation coding. In this technique each sensor is assigned a specific bit code such as 10001 or 10101.

This code must be in the interrogation signal to cause a sensor to respond to the interrogation. In this technique, all sensors numbered 1 could be assigned the frequency 2001 kc with each of the nineteen cells having a unique code. The use of a five bit code provides 32 individual codes and the information data rate is so low that the additional five bits do not impose any burden on the equipment. In this case all 19 sensors receive the transmission, but only the one whose bit code is matched actually responds to the interrogation and transmits a reply.

The use of the first technique will significantly reduce the number of independent channels necessary, and the second will reduce the number of sensors which transmit in response to an interrogation. It is apparent that a frequency spectrum of 50 kc in the area of 2 to 3 mc would be more than adequate for the implementation of the radio link for the automatic remote sensor network.

Data received at the AMOS unit from the set of sensors reporting to it are entered into the AMOS unit for temporary storage. It appears that one entry channel would suffice to handle the radiological data. The radiation and weather data are formatted, fixed data is appended, and the formatted message is placed in the appropriate output channel. On a command

issued by the Interchange Center to which the AMOS reports the message is transmitted over low speed lines to the Interchange. From here, as in the Shelter-Based System, transmission would be made to Cleveland or Atlanta and then to the National Center. Transmissions to Regional Headquarters would occur on the low speed area circuit on which the AMOS unit is located.

Though the use of an AMOS unit at the relay point is in the spirit and philosophy of the Automatic System, the system is not technically dependent on AMOS and the automatic sensing unit could be used with the relay technique described for the Shelter-Based System. Thus a hybrid system is feasible, in which automatic sensors are used in areas of low population density where shelter distribution suitable for the Shelter-Based System may not exist.

With the automatic sensor-transmitter described for the Automatic System it is feasible to develop an airborne unit which would interrogate the sensors as it flies over them. It might be desirable to have a limited number of such airborne units available for use in case of failure of the recommended communications paths. No added complexity in the ground unit is needed in order to permit this possibility. Airborne interrogations could occur over one area while the system is operating in another area. In fact both could be occurring over the same area with only a chance of the airborne interrogations interfering with the system interrogations.

## 5.0 THE HUMAN FACTOR IN RADIOLOGICAL SYSTEM FUNCTIONING

Whether a semi-automatic or an automatic monitoring system is adopted a substantial effort concerning its personnel subsystem will be required. Among the areas of interest are those tasks concerned with installation, calibration, and maintenance of sensors; installation, checkout, operation, maintenance and repair of communications gear; operation and maintenance of computing equipment; and decision making and response implementation tasks.

It can be expected that a number of malfunctions will occur and these will force the decision-makers to operate with partial knowledge. When additional gaps in information flow occur because of bomb damage, the decision making function will be further complicated. Therefore, one of the seriously needed efforts, before-the-event, is a specification of the types of remedial actions which should be undertaken in the event of certain contingencies (the general nature of which can be forecast).

In addition to these research studies, consideration must be given to the design and introduction of a comprehensive training program, to develop skills and to sustain them over an extended period of preparedness. Central in the conduct of such a program is the problem of motivation, a problem which has critical elements simply because of the nature of the tasks for which personnel are to be trained.

One of these elements involves training for a contingency which may never arise. It is relatively easy to arouse a high level of motivation for training when the training period is short and the application is definite (as, for instance, the

sharp increase in military enlistments when a nation is threatened). It is more difficult to sustain a high percentage of attendance during an extended training program when the threat is not imminent (e.g., regularly scheduled military reserve training programs). And it is substantially more difficult still to conduct a successful program in the absence of such incentives as points for retirement or monetary rewards.

The second critical element involves another aspect of motivation, that of accepting one's responsibilities in the event of an attack. In a sense, the civil defense training program may be regarded as a sort of "fire drill", i.e., a series of exercises conducted over time to train people in physical acts which may, in the event of actual emergency, save their lives. But, as with a fire drill, there is no assurance that this training will be completely recalled during periods of emotional stress. This may be particularly true if one's family is exposed to hazard. Despite the scope and intensity of the training effort, it is entirely possible that persons trained for critical assignments may simply fail to report to assigned duty stations during an emergency. This is a likely contingency which can be met in either of two ways. Either the system is designed to be operated substantially without human assistance, or the families of at least the indispensable personnel are physically located at or near the duty station during an attack. A system can be designed to operate automatically on all levels save the top, decision-making levels. Unless the decision makers are at their stations, there is really no justification in having a monitoring system.

A comprehensive training program should incorporate a carefully phased group training cycle. Initially, for example, training might concentrate upon system readiness personnel, i.e., persons

responsible for installation, checkout, periodic maintenance and calibration of sensors, communications gear, data processing equipments, and displays. Training exercises might be structured by the national civil defense organization for administration by the regional training staffs.

Concurrently, training may begin for operating personnel and for persons with leadership responsibilities in the event of attack. Such training, again, would be structured by the national civil defense headquarters. In this case, however, a portion of the program would be administered regionally and a portion would be under national headquarters cognizance.

It is important that each person understand and be able to perform his role in the event of attack. The training program must be structured to afford practice in system operation and should then progress to increasingly "difficult" exercises in which failures are introduced in the simulated system operation. Because of the variety of emergency conditions which might be anticipated, this sort of training would best be accomplished on a small-group basis, simulating inputs from other portions of the system. This permits efficient use of available training time.

Finally, periodic full-system exercises (i.e., civilian "war games" or "maneuvers") might be conducted both to test full system readiness and to afford the individual teams the opportunity for coordination training.

These issues may be beyond the scope of the present research project, but they are issues which were encountered by members of the project staff during data collection efforts. For this reason, they are included here.

For the present study, emphasis centered upon the training issue directly concerned with the proposed monitoring system involving a manned relay point. In the design of the relay point input panel, two essential requirements were considered. The panel must permit insertion of radiological data with a minimum of human error and, in the event that the shelter leader be absent or incapacitated, the panel should be capable of operation even by an untrained person. Steps taken to develop and test the panel design within these constraints are discussed below.

In order to reduce communications requirement and costs, a number of stations in the Shelter-Based system would report to one Relay Point, which would forward the data to Regional Headquarters. The number was set at seven stations, one of which would be the relay point.

A number of techniques were possible at this stage, and their relative effectiveness may be assessed in terms of time required for their accomplishment. For example, since Regional Headquarters will be receiving inputs hourly from hundreds of relay shelters, it is apparent that any single relay shelter input must be made in a matter of seconds. This would appear to rule out the use of verbal inputs to the Regional level.

The method selected involves an interrogation signal initiated at the FAA Service A Weather Observation stations. Each of these stations will be connected by land lines to a number of relay shelters, and a stepper will control the order in which each shelter is interrogated. In the recommended system, the interrogation signal will initiate sensing of positions of a series of rotary selector switches which have been manually positioned (see figure IV-20).

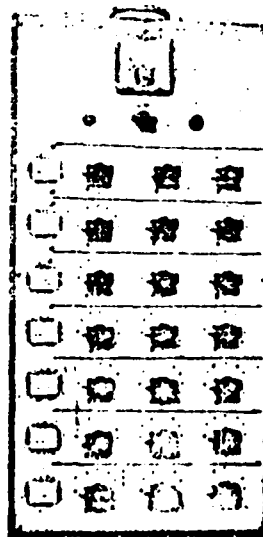

Figure IV-20. Mock-up of Relay Point Control Panel

Any information system which is to be used by men must follow certain principles for efficiency of input. First, data should be converted to machine language as soon as possible to minimize error and confusion. Secondly, input should be paced by the machine rather than by the man so that a maximum amount of information can be entered in a given amount of time. This means that the man should complete his task before the system begins its task.

A device to accomplish this could consist only of the recording elements which the operator manipulates. Looked at from the point of view of the system, such a device is complete and adequate if it can also signal that the operator has completed his task. Because the device is the interface between man and machine, it must also be looked at from the point of view of the man. The device should motivate the man to enter information which is as correct as possible and as current as possible. Especially to be avoided is the feeling that the operator is "shouting into the void". With no direct telephonic communication with the collecting part of the system, the operator must be signalled that he has been heard.

This signal must be provided to accomplish a maximum result at a minimum expenditure in initial cost and in power. A single light is provided to be activated by a single relay. The relay, set by hand, remains closed only during the period that the information has been completely entered and is waiting to be read out.

The sequence of actions on the entry panel is as follows:

1. Operator receives readings from satellite shelters, and sets switches.

2. Operator reads own meter and sets switches.
3. Operator pushes button to set relay. Light comes on.
4. Circuit polling pulse reads switches. Light is extinguished at end of read-out.
5. Operator sets switches to "off" position. This procedure is intended to permit detection (during processing) of cases of failure to change settings for a new reading.

The system as thus conceived appears to involve four potential sources of human error: (1) The local shelter leader may read his meter incorrectly, (2) either he or the relay shelter leader may transpose digits in passing the data (3) the relay shelter leader may make an error in setting the switches, or (4) he may fail to set the switches. During the course of the study, consideration was given to each of these potential sources of error. Each of these is discussed below.

#### 5.1 Meter Readings

The radiological meter recommended for use in the network, Model CD.V-711BX may provide erroneous readings in two ways as a result of human error (excluding the obvious physical damage that may result from careless handling). Calibration errors may occur either initially or during periodic maintenance, and reading errors may occur as a consequence of the scale graduations and requirements for multiplying.

The test of the extent and nature of meter reading errors was begun by drafting an exact copy of the meter scale from engineering drawings (see figure IV-21). Twenty duplicate copies were then prepared. On each copy a pointer was drawn so that twenty different scale settings were represented. The drawings were then sorted into four groups of five drawings each to provide for selector switch settings of X1, X10, X100 and X1000.

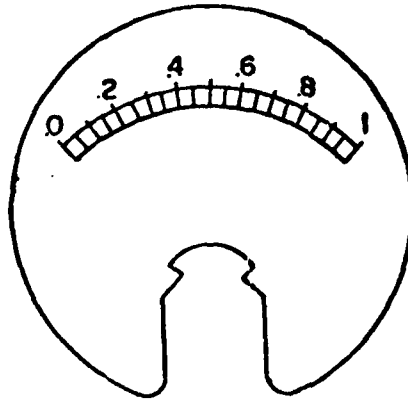

A. Present Scale

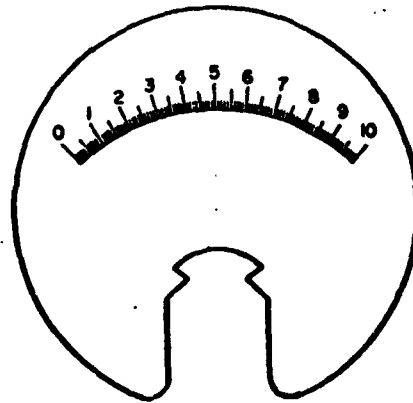

B. Modified Scale Recommended for this System

Figure IV-21. Illustration of Present and Recommended Scales

The test was administered to ten subjects, with instructions to read the scales as accurately as possible and to multiply each reading by the value designated beside each scale.

Four of the ten subjects made at least one error in moving the decimal point. Thirty-four such errors were made (of 200 readings taken). The mean error which would have been introduced had such readings been made in earnest was approximately 500 R/hr.

Disregarding the decimal errors, it was apparent from the results that three figures cannot be read reliably from the scale. When a third figure was cited by the subjects, it invariably was either 0 or 5, and in only 56 percent of the readings was the third figure recorded. Thirty-five percent of the readings were to two significant figures and the remainder were but to one figure despite the instructions to read the scale as accurately as possible.

The median deviation from each setting (disregarding decimal placement) indicated an average two percent reading error. Thus, the probable error for a reading in the 500-1,000 R/hr. range is  $\pm 15$  R/hr., a 250 R/hr. reading would have a probable error of  $\pm 5$  R/hr., etc.

The use of scales which have cardinal values in tenths of roentgens per hour seems to provide an error likely situation. The increased opportunity for error is inherent in the requirement to move decimals and a simpler radiometer scale seems to be advisable.

A suggested modification is to remove the decimals so that the scale is numbered consecutively from 1 to 10 R/hr. Between these numbered values, the scale should be graduated in tenths, with

the fifth calibration slightly larger. This modified scale was tested for improvements in reading accuracy using the same research design and essentially the same subjects as were previously used.\*

Precisely the same testing procedure was employed, in that twenty duplicate copies of the new scale were bound in booklet form. This time, since the cardinal scale values were in whole numbers, the multipliers were 0.1, 1, 10, and 100.

The test indicated that the recommended scale provided substantially greater reading accuracy. In this administration, one of the ten subjects committed the decimal point type error, making two such mistakes in his twenty readings. This may be compared with the 34 decimal errors made on the first test.

Disregarding the decimal errors, the median deviation from each setting indicated an average reading error less than two-tenths of one per cent. Thus, the probable error for a reading in the 500-1000 R range would be  $\pm 1.5 R$ .

The substantially increased reading accuracy which the modified scale permits may be attributed to two features: the finer scale graduations and the elimination of the decimal values on the scale itself.

## 5.2 Transposition Errors

These errors may occur during the telephone transmission of local shelter readings to the relay station, or during the setting of rotary switch positions. Thus, 2-5-8 may be entered as 2-8-5. One method to reduce this type of error is to repeat back and, since an hour is available to record six shelter readings, the

\*Personnel changes which occurred between the two test periods precluded using precisely the same subjects.

extra time required for this does not appear to present a problem.

### 5.3 Switch-Positioning Errors

During conduct of the study, the susceptibility to error of the recommended panel design was subjected to test. A mockup of the panel was prepared (see figure IV-20) and the rotary selector switches were wired so that complete accuracy in setting specific intensities would complete a simple circuit. The subject, in this instance, would be "rewarded" with a light indicating correctness of response.

A voltmeter was mounted at the top of the panel. Its scale was replaced by a replica of the scale the radiometer, Model CDV 711 BX, and a 4-position selector switch was wired to the voltmeter through four different resistors to provide different readings for the multipliers X1, X10, X100 and X1000. Thus, two experiments could be conducted concurrently: a cross-check on the accuracy of the previous study of radiometer reading errors, and a check on the accuracy of positioning the selector switches.

Only seven subjects were used but the results are, we believe, indicative of the accuracies that might be expected were the panel to be introduced into operational use.

Since each of the seven subjects was exposed to four trials, there were 28 meter readings made, and 196 switch settings. Of the 28 meter readings, 15 were in error (mean = 24 R/hr; median = 5 R/hr which generally corroborated the previous findings reported above. That is, three of the 28 meter readings involved misplaced decimals.

There were no errors made in the 196 station settings involving positioning of the rotary switches in response to "read in" values.

It would appear that the panel design provides for reliable inputs to be made to the system if modifications of the meter face are undertaken.

#### 5.4 Omission Errors

Finally, erroneous readings may be introduced into the system in the event that the relay station operator fails to enter a reading obtained from a local shelter.

In this instance there is no opportunity for an internal check and an erroneous previous setting would be forwarded with the remaining settings.

One way in which the occurrence of this type of error might be reduced is to include in the "panel operating instructions" a provision for returning all switches to a reserved 11th position after the panel is interrogated by the system. The interrogation signal turns off a light to remind the operator to turn his switches to this position. Then, if he failed to enter a shelter's reading, or if a shelter failed to report, a special signal would be received from the panel during interrogation.

6.0 SYSTEM COST ESTIMATES

6.1 Shelter-Based System Costs

6.1.1 Sensor Location

Sensor	200	
Installation	<u>40</u>	
Total		240

6.1.2 Relay Point<sup>1</sup>

Switch Panel	920	
Installation	<u>60</u>	
Total		980

6.1.3 Regional Headquarters

Computer	600,000	
Plotter	40,000	
Installation	<u>30,000</u>	
Total		670,000

6.1.4 Recurring Cost

A. Service A Network (share)**	60,000/yr
B. Additional circuits	
For regional & national centers	60,000/yr
Relay to Service A links, per relay point	700/yr

\* Cost of telephone or shelter transceiver is not included(see Section III.2.1)

\*\*Suggested amount to be contributed for standby and exercising rights. Actual amount to be negotiated.

C. Regional headquarters personnel  
 (1 region overhead included)

3 computer operators	50,000	
5 computer programmers	<u>125,000</u>	
Total per region		175,000/yr

D. Additional equipment (Western Union  
 Model 115 Teleprinter System)  
 per weather observation station

		1,800/yr
--	--	----------

E. Maintenance

Sensor location		25/yr
Relay point		100/yr

6.1.5 Summary of Initial Costs

<u>Quantity</u>	<u>Item</u>	<u>Cost</u>
20,000	Sensor location @240	4,800,000
3,000	Relay points @980	2,940,000
8	Regional headquarters @670,000	<u>5,360,000</u>
	<b>Total</b>	<b>13,100,000</b>

6.1.6 Summary of Recurring Costs

<u>Quantity</u>	<u>Item</u>	<u>Cost</u>
1	Service A Network	60,000
1	Additional circuits, regional & national centers	60,000
3,000	Additional circuits relay to Service A network	2,100,000

600	Additional equipment	
	weather observation station	1,000,000
20,000	Maintenance, sensor location @25	500,000
3,000	Maintenance, relay point @100	300,000
8	Regional personnel groups @175,000	<u>1,400,000</u>
	Total	5,500,000

## 6.2 Automatic System Costs

### 6.2.1 Sensor location

Sensor	\$200	
Amplifier	45	
A/D Converter	150	
Transmitter	450	
Receiver	150	
Installation	<u>65</u>	
Total		1060

### 6.2.2 Relay Point

AMOS (share) *	340	
Receiver	700	
Transmitter	450	
Timer	90	
Installation	<u>150</u>	
Total		1730

\* Suggested amount based on the use of one input channel. Actual amount would have to be negotiated.

### 6.2.3 Regional Headquarters

Computer	\$600,000	
Plotter	40,000	
Installation	<u>30,000</u>	
Total		670,000

### 6.2.4 Recurring Costs

A. Service A Network (share) *1		60,000/yr
B. Additional circuits to Regional and National Centers		60,000/yr
C. Regional headquarters personnel (1 region, overhead included)		
3 computer operators	50,000	
5 computer programmers	125,000	
Total per region		175,000/yr
D. Maintenance		
Sensor location		\$50/yr
Relay point		60/yr

### 6.2.5 Summary of Initial Costs

<u>Quantity</u>	<u>Item</u>	<u>Cost</u>
20,000	Sensor locations @1060	\$21,200,000
1,000	Relay points @1730	1,730,000
8	Regional Headquarters @670,000	<u>5,360,000</u>
Total		28,290,000

\* Suggested amount to be contributed for standby and exercising rights. Actual amount to be negotiated.

6.2.6 Summary of Recurring Costs

<u>Quantity</u>	<u>Item</u>	<u>Cost</u>
1	Service A Network	\$ 60,000
1	Additional circuits to Regional and National Centers	60,000
20,000	Sensor location maintenance @\$50	1,000,000
1,000	Relay point maintenance @\$60	60,000
8	Region personnel groups @\$175,000	<u>1,400,000</u>
	Total	\$2,580,000

## 7.9 COST VERSUS EFFECTIVENESS

In order to judge the value of the proposed radiological monitoring system it is desirable to compare its effectiveness with that of alternative methods of obtaining estimates of radiation intensities, e.g., from fallout models using burst and weather data but no monitored intensities. No direct comparison is possible at this time since no data are available that were obtained with identical input conditions. However, a University of California report<sup>(8)</sup> provides a basis for making at least a preliminary estimate of the gain in accuracy that is possible with the use of monitored intensities.

The California study, using a stochastic wind model and data on winter winds over Oakland, California, obtained the minimum variance linear (MVL) estimate of the deposition coordinates of particles of various sizes. These results were combined with a cloud model to estimate the radiological intensities from a burst of 2.5 megatons. On the basis of the probability distributions derived from the wind model it was estimated that with 90 percent probability the ratio of the estimated intensity obtained from the regression procedure,  $\hat{W}$  (conforming with the notation used in previous sections), to actual intensity,  $W$ , is within the following ranges, depending on distance from the burst point:

<u>Location</u>	$\hat{W}$	<u>Probability Statement</u>
near	1200 r/hr	$P(.530 \leq \hat{W}/W \leq 1.87) = .90$
intermediate	600 r/hr	$P(.172 \leq \hat{W}/W \leq 5.81) = .90$
distant	150 r/hr	$P(.056 \leq \hat{W}/W \leq 17.81) = .90$

K&E SEMI-LOGARITHMIC 358-91  
 HEUPPEL & KESNER CO. MADE IN U.S.A.  
 9 CYCLES X 70 DIVISIONS

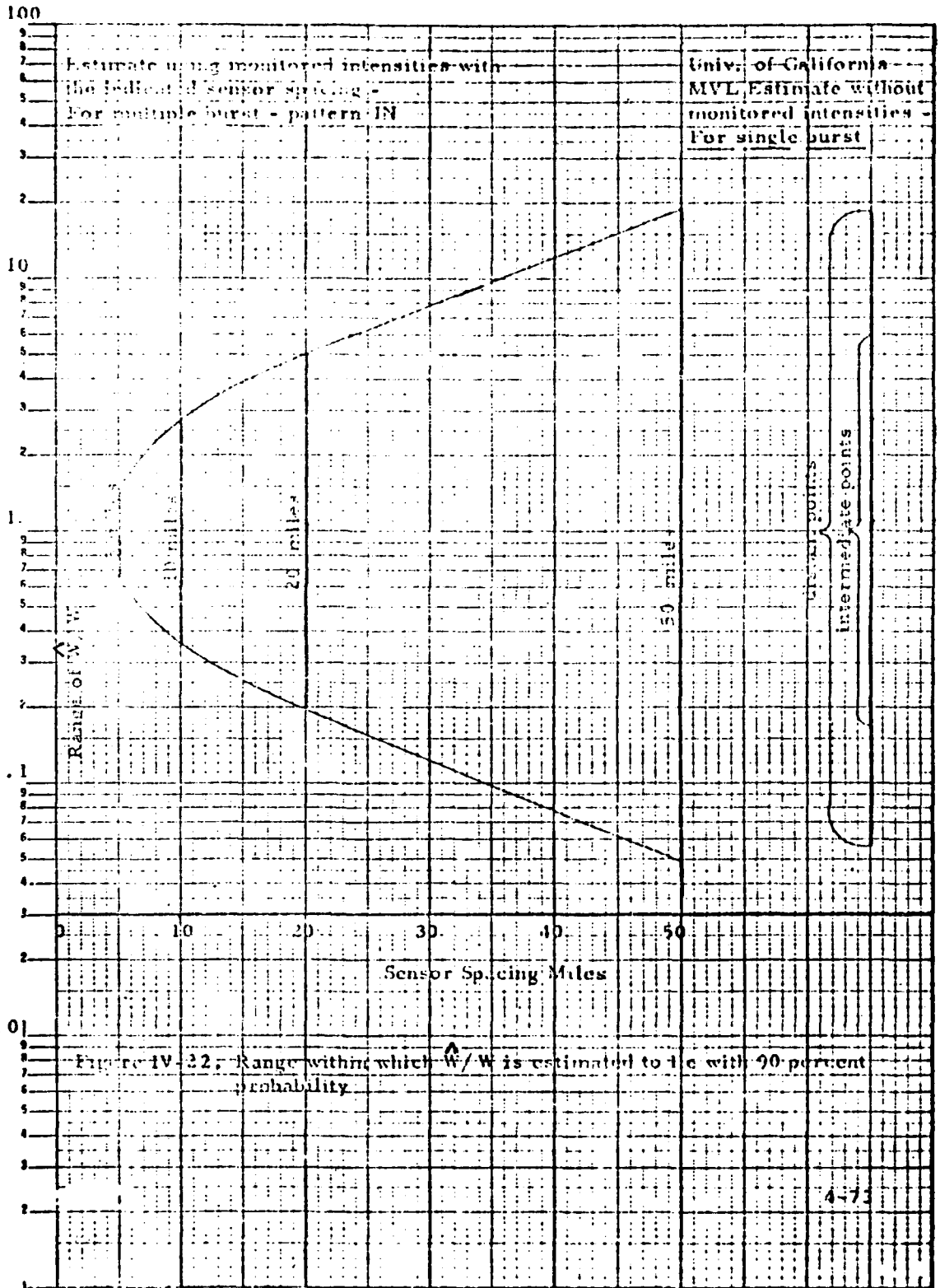

Figure IV-22 compares these ranges with some obtained from the simulation for sensor spacings of 5, 10, 20 and 50 miles and with pattern 1N. The ranges were obtained from simulation data on Type 1 errors only.

Note that the range with 50 mile spacing is approximately equal to the MVL estimate for "distant" points while that for 20 mile spacing is slightly less than the MVL estimate for "intermediate" points. The range for 5 mile spacing is an interval with about 15 percent the length of that for the MVL estimate for intermediate points and about 5 percent of the length of that for distant points (on a linear scale). No comparison is made with "near" points where the intensity shown in the above table is outside the range of the monitoring system.

Several caveats are in order in connection with this comparison. First the sampling error for estimates of the 90th percentile of the distributions from the simulation is not known and may be fairly large. This is a difficulty that could be resolved if time were available to make the necessary computations.

The second difficulty is the difference in input assumptions. The simulation runs were obtained from a pattern representing multiple bursts. Presumably the regression procedure is not currently developed to the point where multiple bursts can be taken into account so that in this sense the comparison is biased in favor of the MVL estimates. Pattern 2 used in the simulation, which represents a single burst, was not used for this comparison since the range of intensities was considerably less than that for the MVL estimate. To estimate an upper bound for this bias it may be noted that with pattern 2 and a 20 mile spacing  $\hat{W}/W$  was between

1/3 and 3 for 90 percent of the points. This interval has about half the length of that for the intermediate MVL estimate and about 15 percent of the length of that for the distant MVL estimate.

Estimates obtained from a fallout model without monitored intensities can be expected to decrease in accuracy with increasing distance from the burst point as the range for the MVL estimates indicates. On the other hand the accuracy of estimates from a sensor network would not be expected to exhibit this property. In fact, it is the nearby points at which the monitoring system would have its greatest difficulty since the probability of sensor survival would be least and intensity gradients would in general be greatest near the burst point. Thus the two procedures for obtaining estimates are complementary.

An unanswered question is what could be gained by combining the two procedures, i.e. by using monitored intensities to improve the estimation of parameters of a fallout model over that currently possible with only burst and weather data. Such a model which could be used for interpolation with respect to distance (i.e. for estimation of intensities at points other than sensor points) and extrapolation with respect to time (i.e. for prediction) was the goal of the University of California study referred to above; however not all of the mathematical difficulties have been resolved.

Finally, it should be noted that the University of California report indicates that the MVL estimate represents a significant gain in precision over estimates obtained from fallout models using persistent winds taken from measurements at a single point in time or from climatological mean winds. Thus the range shown in figure IV-22 for the MVL estimate can be assumed to be significantly

less than that which would result from estimates obtained from some fallout models in current use.

In order to compare cost and effectiveness for sensor networks of varying sensor spacings, figures IV-22 to IV-27 were plotted.

Two measurements of effectiveness are shown. In figure IV-23 the ranges of figure IV-22 have been replotted against the ratio of initial cost for a given spacing to that for a 20 mile spacing in an automatic system. Table IV-4 gives the actual costs using the data of section IV.6.2.5.

Table IV-4. Initial Cost, Automatic System

Sensor Spacing, D (miles)	Cost, C (millions of dollars)	Cost Ratio
5	160	9.6
10	45.3	2.7
20	16.6	1.0
50	8.61	.52

$$C = (7.09 + 3820/D^2) (10^6)$$

Thus by increasing the cost over that for a 20 mile spacing by a factor of 2.7 the length of the 90 percent confidence interval for  $\hat{W}/W$  is cut in half (on a linear scale). With cost increased by a factor of 9.6 the length of the interval is about 20 percent of that for a 20 mile spacing.

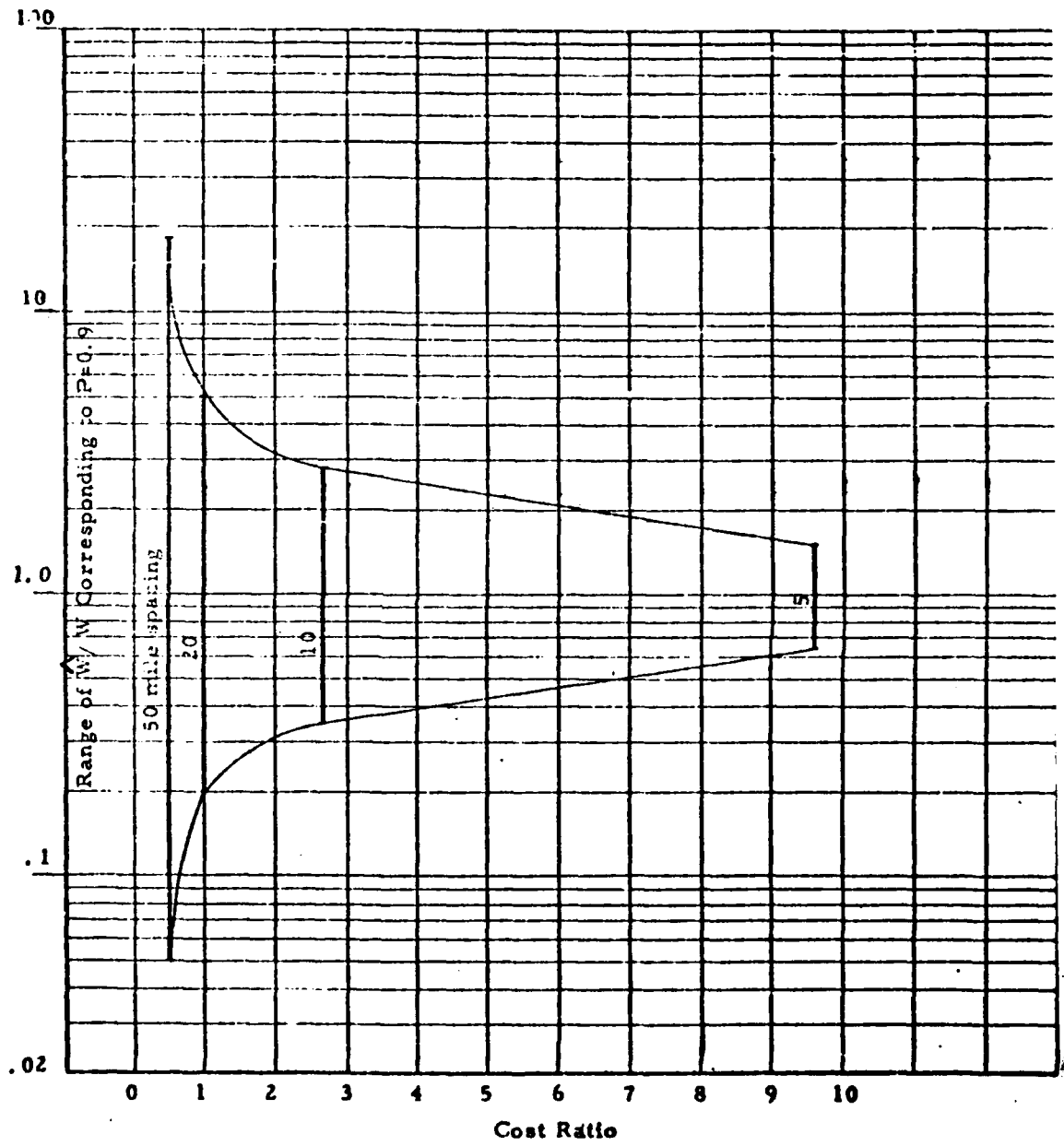

Figure IV-23, Initial Cost Ratio, Automatic System

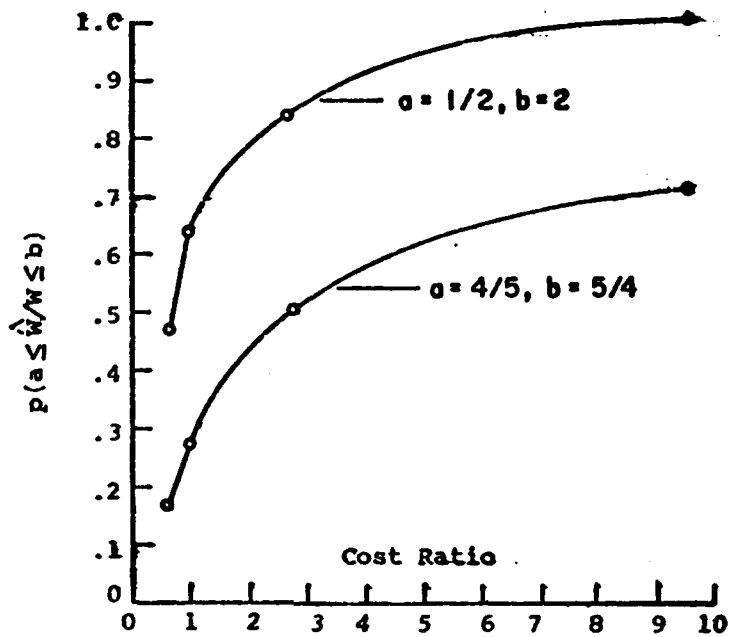

Figure IV-24. Initial Cost Ratio, Automatic System

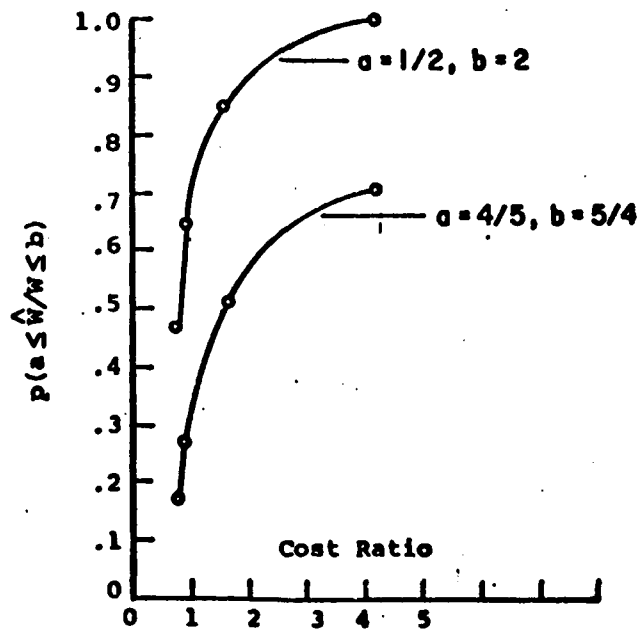

Figure IV-25. Recurring Cost Ratio, Automatic System

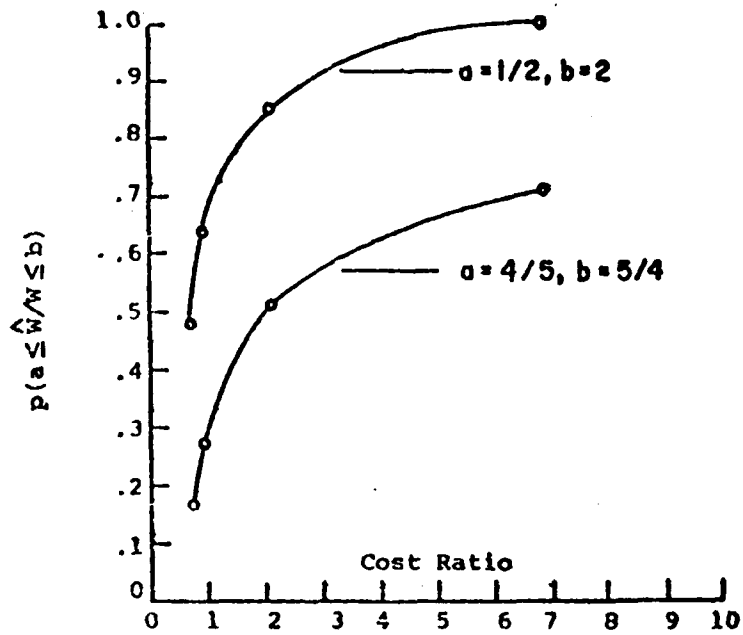

Figure IV-26. Initial Cost Ratio, Shelter-Based System

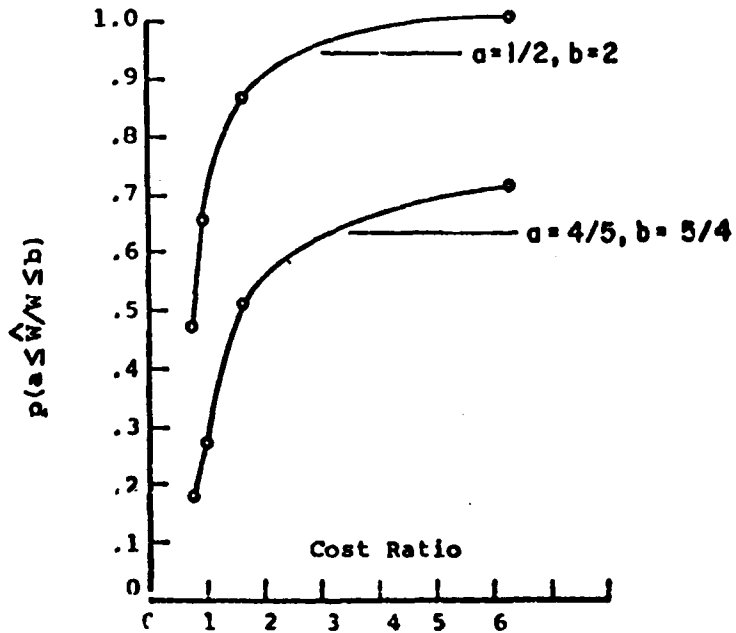

Figure IV-27. Recurring Cost Ratio, Shelter-Based System

Figure IV-24 plots the estimated probability that  $\hat{W}/W$  is within a given range against initial cost of an automatic system. Again cost is given as the ratio with respect to that for a 20 mile spacing. For the simulation of a 20 mile spacing and pattern 1N, 64 percent of the type I errors were such that  $\hat{W}/W$  was between .5 and 2. The relative frequency increased to 85 percent for a 10 mile spacing, which increased the cost 270%. For a 5 mile spacing and the Mod II method of estimation,  $\hat{W}/W$  was between .5 and 2 for all points. This estimated 100 percent confidence is bought with a 960% increase in cost. A curve is also shown relating cost to the relative frequency of  $\hat{W}/W$  between 4/5 and 5/4.

Figure IV-25 relates the same effectiveness measure to the annual recurring cost of an automatic system. The costs are given in table IV-5 and are based on the data in section IV.6.2.6.

Table IV-5. Annual Cost, Automatic System

Sensor Spacing, D (miles)	Cost, C (millions of dollars)	Cost Ratio
5	8.78	4.3
10	3.38	1.7
20	2.03	1.0
50	1.65	.81

$$C = (1.58 + 180/D^2) (10^6)$$

Figures IV-26 and IV-27 show the same relationships for costs of a shelter-based system, assuming that a uniform spacing

of shelters is possible within the area covered by the fallout pattern. The costs are given in tables IV-6 and IV-7, and are based on the data in section IV.6.1.5.

Table IV-6. Initial Cost, Shelter-Based System

Sensor Spacing, D (miles)	Cost, C (millions of dollars)	Cost Ratio
5	60.2	6.9
10	19.1	2.2
20	8.79	1.0
50	5.91	.67

$$C = (5.36 + 1370/D^2) (10^6)$$

Table IV-7. Recurring Cost, Shelter-Based System

Sensor Spacing, D (miles)	Cost, C (millions of dollars)	Cost Ratio
5	22.7	5.9
10	7.61	2.0
20	3.85	1.0
50	2.80	.73

$$C = (2.60 + 501/D^2) (10^6)$$

Examination of figures IV-24 to IV-27 shows that relatively large increases in accuracy result from relatively small increases in system cost until sensor spacings of about 20 miles are reached, for either the Shelter-Based or Automatic System. Expenditures for

a 20 mile spacing would appear to be justified for nearly all areas of the nation.

Substantial accuracy benefits result from further decrease in spacing down to 10 miles, and these costs would appear to be justified for densely populated areas. Further benefits result from even further decreases in spacing, and spacings down to 6 miles might be justified in very densely populated metropolitan areas, even though costs are increased substantially. Below 6 miles, large increases in system cost bring only small increases in accuracy, and these spacings are not recommended.

Recommended spacings, then, range from 6 miles in the most densely populated cities, to 20 miles in areas with low population density.

The placement pattern would be approximately hexagonal, with distortions as the spacing changes, and distortions due to shelter locations. A hexagonal arrangement would be recommended for the Automatic System, also, if that system were to be adopted.

In some mountain states, particularly, there will be areas where no shelters lie within a few miles of the desired point. In this case the sensors should be placed where shelters do exist, with an approximate density similar to that which would result from 20 mile spacing, even though the pattern becomes irregular. If shelter densities do not permit the recommended sensor density, sensors should be omitted, and the degraded accuracy which will result should be accepted. (The benefits of sensors in areas of low population density derive mostly from data use for (1) prediction for other areas and (2) finding safe areas; and degraded accuracy

for these purposes is considered acceptable when the cost of overcoming it would be high.)

#### REFERENCES

- (1) Betty W. Holz and Charles E. Clark, Tests of Randomness of the Bits of a Set of Pseudo-Random Numbers, The Johns Hopkins University Operations Research Office, ORO-SP-77, 1958.
- (2) R. C. Grassi, Iso-intensity and Iso-dose Contour Plots for Various Probability Levels, Central California and Western United States, University of California, Contract No. CD-SR-58-40, March 31, 1958.
- (3) S. M. Greenfield, R. R. Rapp, and P. A. Walters, A Catalogue of Fallout Patterns, The RAND Corporation, RM-1676-AEC, April 16, 1956.
- (4) G. E. P. Box and M. E. Muller, A Note on the Generation of Normal Deviates, Ann. Math. Stat. 28 (1958), 610-611.
- (5) Ford Instrument Co., Fallout Predictor, SC-78185, Contract DA-36-039, Quarterly Report #5, 1960.
- (6) W. L. Owen and J. D. Sartor, Radiological Recovery of Land Target Components, U. S. Naval Radiological Defense Laboratories, 1962.
- (7) C. F. Miller, Fallout and Radiological Countermeasures, Part 2, The Distribution of Fallout Particles Following a Nuclear Detonation, Office of Civil Defense, June 1962.
- (8) D. C. Kleinecke and R. R. Read, A Discussion of the Feasibility of Estimating Fallout by Regression Methods, University of California, Berkeley, CDRP-i82-105, September 25, 1962.

SECTION V  
SYSTEM EVALUATION

1.0 EFFECTIVENESS

Effectiveness was defined earlier as the probability of knowing to a specified accuracy the radiation intensity at any point and time.

The results of the simulation, reported in section IV.2 relate information accuracy to sensor spacing for specified assumptions as to the distribution of measurement errors and malfunction probability, and with points specified at which sensors would be assumed to be destroyed by blast. The values of these parameters were chosen to test assumptions concerning the hardware elements of the system. In order to assess their applicability to the Shelter-Based System an estimate must be made of the effect of the human element on these parameter values. The effect of the human element on reliability and invulnerability, which in turn has an impact on effectiveness, is discussed below. With appropriate training, motivation, and discipline, it may be possible for the over-all effectiveness of the Shelter-Based System to be limited by the characteristics of the hardware elements of the system.

2.0 COST

The advantage lies with the Shelter-Based System with respect to initial cost and with the Automatic System with respect to recurring cost. When the two costs are combined, the total outlay for the Shelter-Based System is less for the first five years while beyond that time the total cost is less for the Automatic System.

Concerning the Shelter-Based System, if some portion of the cost for communications between shelter and Relay Point is charged to the radiological monitoring system, the crossover point is reduced below five years. On the other hand, interest computed on the total outlay tends to increase the crossover point.

### 3.0 SPEED OF RESPONSE

In both systems collection and transmission of data to national and regional headquarters can be completed within an hour. However, the Automatic System has an advantage with respect to the length of the interval during which sensor data are being collected at the Relay Points and put on the communications line. Not only can the length of the interval be expected to be shorter for the Automatic System, but the delay for a given sensor would also be more uniform, thus providing greater accuracy and uniformity to time coordinates associated with radiological data. However, response time of both systems is good, and this advantage is not critical.

### 4.0 RELIABILITY

It is not clear where the advantage lies with respect to reliability since human performance during a disaster cannot be predicted with confidence.

In the Automatic System estimates of reliability are made under the assumption that the system must perform without maintenance during the critical period following an attack. In the Shelter-Based System it may be possible to perform first echelon maintenance to those elements that are attended.

There is greater redundancy in the Shelter-Based System. For example, if a relay shelter does not receive data from one of the shelters by the normal procedure, it may be possible to improvise means for obtaining the data, though time imposes a limit on the extent to which such procedures could be followed. Likewise, if a satellite shelter is destroyed, another might be substituted.

#### 5.0 INVULNERABILITY

The simulation included the effect of blast damage at the sensor locations but did not consider the effect of damage to communications. For the land line communications used in both the Automatic and Shelter-Based Systems, redundancy and avoidance of probable target areas increase chances of the systems' surviving.

A critical link in the Shelter-Based System is the operator in the weather observation station. Unless fallout protection is provided, or unless he is replaced by automatic equipment, radiation may prevent the operator at a weather observation station from discharging his functions, thus preventing certain data from reaching national and regional headquarters.

#### 6.0 IMPLEMENTATION FEASIBILITY

Neither the Automatic nor the Shelter-Based System depends on the development of any essentially new hardware. Both systems depend on the feasibility of using the FAA Service A communications network (or of building a substitute at a very substantially increased cost to the system).

The Automatic System as described depends on the availability of AMOS. However, in case the AMOS program is not implemented by the weather service or its use is denied to the Department of Defense the system objectives could still be met by substitution of equipment to perform the AMOS function. The system cost would be comparable to that based on using AMOS.

The Shelter-Based System depends on the implementation of a nationwide shelter program with inter-shelter communications. However, if community shelters with appropriate communications were, for example, provided only in metropolitan areas a hybrid automatic-Shelter-Based System could be used.

#### 7.0 FLEXIBILITY

Both systems have considerable flexibility. For example, either system could be implemented in phases. Both systems could accept substitutions of new types of elements without major system redesign (for example, substitution of other types of relay equipment for AMOS or the combination of unattended sensors in some parts of the country with Shelter-Based sensors in other parts).

Between the Automatic and the Shelter-Based Systems, the latter has an advantage with respect to accepting additional functions. For example, the switches at the relay shelters could be set to provide other types of data such as numbers of people in shelters, accumulated radiological doses, number of man-days of food, etc.

## 8.0 LIMITATIONS OF SYSTEMS

A basic limitation of both the Shelter-Based System and the Automatic System is that the local operational needs for radiological data will not be met by these systems. Plans and efforts towards meeting local needs by means of manual monitoring should not be diminished even if one of these systems is implemented.

A second limitation of both systems is that the communications network (FAA Service A) does not exist for transmission of radiological data only. Clearly a communications network designed to meet radiological needs could be built, but at a substantial increase in the initial cost of the monitoring system.

Both systems produce information at Regional Headquarters which is intended to result in plans, decisions, and recommendations which will affect State, County, and Local headquarters. Normal Civil Defense channels are relied upon for communications of these items. Inadequacy of those channels may be a limitation; however, this is not considered a limitation of the radiological monitoring system itself.

A limitation of the Shelter-Based System may be that the shelter transceiver or telephone facilities needed for transmission of data from sensor points to Relay Points do not exist in some shelters at present. Other Civil Defense research is underway relating to shelter communication<sup>(1)</sup> and it is assumed here that these facilities will be provided independently of a radiological monitoring system. If not, they would have to be provided for the specific shelters used in the system.

The Shelter-Based System is dependent on persons to take intensity readings. However, this is not considered a limitation since these persons would be located in shelters. These persons will not be completely occupied with other tasks and will have ample time to take readings; in fact, they will want to know the outside intensity themselves.

#### REFERENCE

- (1) Fallout Shelter Communications Study, Gautney and Jones, Dec. 1962, Contract OCD-OS-62-123.

SECTION VI  
CONCLUSIONS AND RECOMMENDATIONS

It is concluded from the study that: monitored radiological data is required in the post attack period; a ground-based system appears to be superior to an airborne system; small scale effects could be partly compensated for; and a Shelter-Based System is preferred to the Automatic System.

It is recommended that: a pilot system be constructed to show the design structure and determine the costs more precisely; research on small scale effects be carried to the point of development of a computer program; and a computer program be developed to perform fallout prediction based partly on monitored intensities.

1.0 CONCLUSIONS

1.1 It is concluded that monitored radiological data is required in the period immediately following an attack to improve decision making at regional and national levels. During this critical period, these higher headquarters may well prevent dissolution of the power of federal government to the extent to which they can supply lower echelons with resources and information. An adequate radiological reporting system will help to fulfill both needs.

1.2 Operation of a ground-based system is less sensitive to variations in attack strategy than one which is airborne. It can go into operation from stand-by status at any indicated time. A system of fixed sensors, moreover, ensures that reporting places are exactly known.

1.3 Although fixed sensors "see" only the area immediately surrounding them, it is concluded from specific studies that small scale effects could be partly compensated for and, if care is exercised in sensor placement, reports will not be unduly biased. A system could be installed to give acceptable accuracies within a feasible cost. If existing communication networks having the proper structures could be used, costs could be further held down.

1.4 The Shelter-Based System is preferred because it is a natural outgrowth of the shelter program, and because it requires a lower initial investment. Further, it may be implemented independently of the Automatic Meteorological Observing System (AMOS). If the Automatic System were implemented before the AMOS is fully implemented, the costs of the Automatic Radiological Monitoring System would be higher than those shown. If early implementation of a radiological monitoring system is required, the Shelter-Based System offers advantages.

A hybrid system of manual and automatic devices is also feasible.

## 2.0 RECOMMENDATIONS

### 2.1 Implementation of a Shelter-Based System

The Shelter-Based System is recommended because comparative evaluation against the fully Automatic System showed sufficient advantage to warrant choosing it. The choice is not so clear, however, that judgment could not be reopened on the basis of experience in the pilot study recommended below.

Two courses of action are recommended for consideration. The first consists of simultaneous implementation across the whole country. A second course consists of implementation region by region. If the latter course is chosen, Region 2 is considered suitable for first implementation. The second course avoids the risks implicit in a "turn key" operation; it is evolutionary and requires more time for full implementation. Proper planning allows the system to operate if an emergency should arise before it is fully implemented.

If the Automatic System is implemented it depends in part upon implementation of the AMOS by the Weather Bureau. Although current plans seem firm, the fact that schedules and locations are outside the control of the Office of Civil Defense would introduce complications not present with the Shelter-Based System. On the other hand, uniform implementation of the Shelter-Based System depends on a successful national shelter program.

## 2.2 Pilot System

A pilot system should be built to consist of:

- a. One group of sensors placed in shelters which are approximately hexagonally placed, and which are equipped with telephones. CDV 711BX meters should be supplied with improved scales.
- b. Relay point equipment installed in the shelter designated to serve as relay to higher headquarters. Because this equipment does not now exist, pre-production models should be built from available components (see appendix A) and installed for testing.
- c. A physical connection to the closest observation station of the FAA Service A Network. This would permit transmission to the appropriate Regional and to the National Headquarters.

A sheltered location in the Washington area is suggested for location of the Relay Point equipment. It would be available for test during simulated alerts and for demonstration at any time. The point of tie-in to the weather network would have to be approved by the Weather Bureau; the Washington National Airport is a possibility. Region 2 Headquarters at Olney would receive any test data appended to normal weather traffic, as would other locations normally receiving weather data.

### 2.3 Small Scale Effects

Highly desirable is a computer program which would accept a numerical description of terrain, buildings, and vegetation within the range of the sensor and would compute the effect of the immediate environment on sensor readings. Only relatively fixed parts of the environment could be expected to result in predictable variations. The program might be written either with assumption of a uniform distribution of fallout particles or with a deposition which included probable ground movement. This program would be intended for use at the time of sensor placement.

Hand calculations of effects of environment have been made in some cases, <sup>(1,2)</sup> particularly for planning decontamination. The availability of a program would not only speed these calculations but would permit outside surveys to be made which in their way would be analogous to surveys for shelters inside buildings.

### 2.4 Fallout Prediction Improved by Monitoring

Valuable models are now in use which predict fallout from attack, basing computation upon information about burst and weather. The most sophisticated of these models are embodied in

computer programs because of the size of the computation load. Thus far no use has been made of monitored intensities in programs intended for operational use.

Although one prediction model has been formulated which will accept monitored intensities, <sup>(3,4)</sup> there does not appear to be a computer program available which will make radiation intensity predictions based on monitored intensities as well as on burst and weather information. It is desirable that research leading to such a program be conducted. Since the National Resources Evaluation Center has expressed interest in such a model, a cooperative effort might be considered.

One interesting method for testing such a program would be as follows. From the same set of assumed bursts and the same weather information, make radiation intensity predictions (simulated actual intensities) by means of two different existing computer programs. The results of these predictions may be expected to differ. Then make two predictions with the new prediction program, in one case using selected predicted intensities (simulated monitored intensities) from one of the original predictions, and in the other case using selected intensities from the other original prediction. If the new predictions resemble the corresponding original predictions more closely than the two original predictions resemble each other, it might be expected that the new prediction program would yield results which are closer to the true situation in the event of an actual attack.

The importance of this model does not depend upon the kind of monitoring system installed. Whether radiation is monitored by a manual or an automatic, by a fixed or mobile system or indeed by any specialized system which can be identified, provision should

be made for the monitored data to be added to burst and weather data in arriving at an improved result. The addition of this current data need not impede dissemination of information and it will improve accuracy. The present computation at National Level utilizes a computer program but it should be revised to accept monitored data as well.

This last recommendation conforms well with the basic objective of the study to improve our civil defense posture by improving the collection and processing of radiological data. To this end, the advantages of no specific system were allowed to dominate the thinking where it was possible to use common elements. Complete systems have been advanced in order to test concepts and to force firm recommendations.

- (1) Miller, Carl F. Research Report No. 6. Fallout and Radiological Countermeasures: Target Analysis Procedures. Office of Civil Defense. June 1962.
- (2) Sartor, J. D. and Owen, W. L. Radiological Recovery of Land Target Components, Complex I and II. USNRDL.
- (3) Read, Robert R. and Shepherd, Ronald W. A Probabilistic Basis for Describing the Radiation Intensities of Fallout. Civil Defense Research Project, Series 2, Issue 20. University of California. April 7, 1959.
- (4) Read, Robert R. Interim Report: Technique for Designing and Employing a Radiological Monitoring System for the Event of Attack. Civil Defense Research Project, Series 2, Issue 22. University of California. April 10, 1959.

APPENDIX A  
SPECIFICATIONS FOR RELAY POINT PANEL

1.0 SCOPE

This specification is for a data entry panel to be used in selected fallout shelters to enter gamma radiation dose-rate data from seven points (of which one is the location of the shelter) into a communications network.

2.0 PERFORMANCE REQUIREMENTS

2.1 Each of the seven dose-rate readings will consist of a 3 decimal digit quantity (000 to 999). These quantities are to be manually set on 7 sets of 3 (for a total of 21) ten-position switches. These switches should be Digiswitches or equivalent, so that their output may be in a selected binary code. A stepping switch is to be provided so that upon receipt of an interrogating signal over the communications network, coded versions of the 21 digits are entered, in sequence, into the communications network. Signals and codes used are to be compatible with those of the FAA Service A weather communications network.

2.2 Provision shall be made for mounting the monitoring instrument of a CD V-711BX Radiological Survey Meter.

2.3 A switch and a light shall be provided, such that when the switch is depressed, the light is turned ON and remains ON until receipt of the interrogating signal, at which time the light is turned OFF automatically.

### 3.0 TEMPERATURE REQUIREMENT

The equipment shall function over the temperature range of minus 20°F to plus 125°F. It shall withstand damage during exposure to minus 50°F for 24 hours and exposure to plus 160°F for 72 hours.

### 4.0 COMPONENTS

4.1 Choice.-New components shall be used, and only those components commercially available from at least two domestic manufacturers and meeting standard commercial and military tolerances shall be used.

4.2 Design Target.-Equipment should remain usable for ten years, even though not used, assuming annual maintenance and testing.

4.3 Marking.-Values of resistors and other standard components shall be marked by means of color-code or other standard commercial practice.

### 5.0 POWER SUPPLY

5.1 Type.-The power supply shall consist of 12 volt automobile batteries.

5.2 Performance.-The battery shall be selected from the Federal Qualified Products list.

5.3 Operational Life.-The battery shall operate the instrument intermittently for at least 600 hours without charging.

5.4 A battery charger shall be provided.-The input shall be 110 vac, the output shall be 12 volts nominal. Trickle or full charge shall be possible, with a tapering rate circuit.

## 6.0 INTERNAL CONSTRUCTION

6.1 Access.-All components shall be accessible and replaceable without special tools.

6.2 Circuit Diagram.-A wiring diagram shall be affixed to the inside of the case in a position readily visible when the panel is opened for maintenance. Component values, reference symbols, wire colors, polarities, and nominal operating voltages shall be indicated.

6.3 Corrosion Resistance.-All metallic iron parts shall be treated to resist oxidation.

## 7.0 PHYSICAL CHARACTERISTICS

7.1 Size.-The front of the panel shall be approximately one foot wide ( $\pm 2$  inches) and two feet high ( $\pm 6$  inches). Depth shall be two to six inches.

7.2 Closure.-It shall be convenient to open and close the case for servicing, and the equipment shall be operable with the case open.

7.3 Corners.-Corners of the case shall be rounded to a radius of not less than 1/8 inch. Exposed edges shall be smooth and slightly rounded.

7.4 Provision shall be made for mounting the monitoring instrument (see 2.2) in the top portion of the panel, with the instrument operable and the meter readable.

7.5 Provision shall be made for insertion or attachment of a label (about 1" high and 1½" wide) adjacent to each set of 3 switches. Three dozen blank labels shall be provided with each panel. Provision for storage of extra labels shall exist inside the panel.

7.6 Color.-The case of the instrument shall be bright yellow (similar to Munsell No. 5Y8/12). All paint must be free of sags, runs, blisters, and other imperfections.

7.7 Markings.-All switch positions shall be legibly marked in black with the digits 0 through 9 and OFF. Character height shall be not less than 1/8". The groupings of three switches shall be readily apparent.

#### 8.0 IDENTIFICATION

8.1 Each instrument shall bear the red, white, and blue CD emblem of size approved by the Contracting Officer. Each instrument shall contain the identification: "OCD Item No, \_\_\_\_\_" (to be furnished), a serial number, and the contractor's name, city and state. Consecutive serial numbers beginning with (1) shall be used. All identification shall be approved in advance by the Contracting Officer.

APPENDIX B  
ANALYSIS OF COMMUNICATIONS DELAYS

Let  $x_i$  equal the time to collect data at the interchange center from all relay points on the  $i^{\text{th}}$  circuit. From each sensor 3 characters are transmitted to the relay point. If one additional character, for space mark, is added at the relay point the total number of characters to be collected on the circuit is

$$\sum_{j=1}^{r_i} (3n_j + 1) \quad \text{characters}$$

where  $r_i$  is the number of relays on the  $i^{\text{th}}$  circuit and  $n_j$  is the number of sensors transmitting to the  $j^{\text{th}}$  relay.

Data transmission on the low speed lines which serves each circuit is at the rate of 500 characters per minute. Thus

$$x_i = \frac{\sum_{j=1}^{r_i} (3n_j + 1)}{500} \quad \text{minutes}$$

If it is assumed that each circuit has the same number of relay points,  $r$ , and each relay the same number of sensors  $n$ , this simplifies to

$$x = \frac{r(3n+1)}{500}$$

This assumption is not entirely valid since it is proposed to vary the density of sensors with population density and the 15 Service A network circuits do not serve equal areas. However, the total number of sensors per circuit would probably be fairly uniform since the area served by a circuit appears to decrease with increasing population density. Thus the error in assuming  $r$  and  $n$  to be constant is probably not great. As a test case an estimate of  $x_i$  was made for the two area circuits of the Weather

network which appeared likely to be limiting. The first was the circuit which includes the New York City-New Jersey-Philadelphia metropolitan area, Syracuse, Buffalo, Pittsburgh, and Cleveland. A six-mile sensor spacing was assumed for these metropolitan areas; a 20 mile spacing for the remaining area served by this circuit. It was estimated that 4 minutes would be required to collect sensor data on this circuit. A similar computation was made for the circuit serving California. The estimated time was less than 4 minutes.

Since data collection is performed simultaneously on all 15 circuits, the total time for collection on a national scale is  $x$  in the case of uniform distribution of relays per circuit and sensors per relay.

Let  $y$  be the time to transmit the data from one interchange center (i.e., data from three circuits) on the high speed line. Thus under the uniformity assumption

$$y = \frac{3(3n+1)r}{5000} \quad \text{minutes}$$

since the high speed line transmits data at the rate of 5000 characters per minute.

Let  $T$  be the time required to transmit all radiological data to national headquarters. If the only available communication is the low speed line for the Atlanta interchange center, the value of  $T$  is given by

$$T = 15x$$

This is derived under the assumption that the national center gets all data from the circuit on which it is located during the collection period. Further it is assumed that the Atlanta interchange center has sufficient buffer capacity so that data received via

the high speed line from the other interchange centers is stored and available for continuous transmission via the low speed line to the national center.

If one high speed line is installed between the Atlanta Interchange and the national center, the time is

$$T^1 = x + \frac{14}{3} y$$

If a second high speed line from the Cleveland Interchange to the national center is added, the time is

$$T^{11} = x + 3y$$

If a third high speed line from Kansas City to the national center is added

$$T^{111} = x + 2y$$

These data are summarized in table IV-3.

APPENDIX C  
SMALL SCALE EFFECTS

1.0 PURPOSE

Terrain effects, influence of local weather, and shielding by structures or vegetation are identified as small scale effects. They were studied in order to determine how they influence the design of a radiological reporting system. The study was to determine the manner in which small scale effects influence the gamma radiation field, and whether the influence of small scale effects could be compensated or controlled.

1.1 Basic Structure of the Gamma Radiation Field

The gamma radiation field is generated by the distribution of radioactive fallout. In the absence of small scale effect, the distribution is determined by weapon characteristics and detonation location. (The terrain is then considered to be a plane surface.) The resultant fallout then tends to have constant density over an area defined by a few gamma mean free paths,  $\lambda$ . The gamma radiation field strength at any point can be described by

$$R_o = 2\pi r K S [E_1(\mu_o h) + a e^{-\mu_o h}] \quad (1.1)$$

where  $K$  is the specific intensity,  $S$  is the fallout density,  $\mu_o$  is the total attenuation cross-section,  $h$  is the detector height above the terrain,  $E_1(\mu_o h)$  is the exponential integral, and  $a$  is a coefficient of the build-up factor polynomial.

A good representation of the gamma radiation field is obtained by using the value  $a = 1.45$  for the photon energy range of 0.5 to 0.7 Mev. For the same energy range  $K$  can be taken as

0.39 roentgen/hr. at one meter per curie. The geometry of the problem is given in Figure C-1.

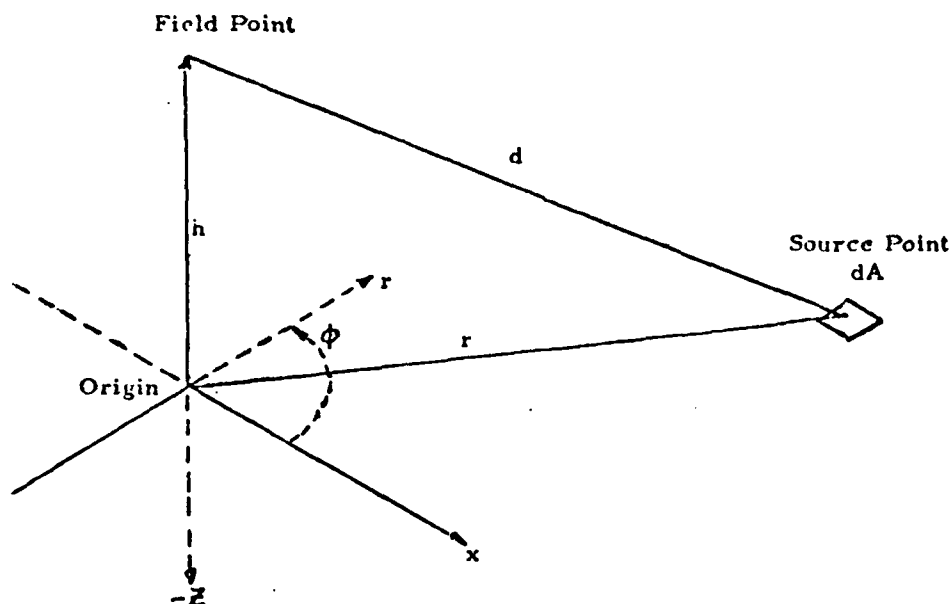

Figure C-1. Gamma Radiation Field Geometry

The contribution of a particular portion of the fallout distribution in this idealized case can be determined. This can be described as a set of curves indicating the contribution to the gamma radiation field strength,  $\Delta R_0$ , of the fallout at a distance greater than a selected distance,  $d_0$ . Table C-1 provides  $\Delta R_0$  vs  $d_0$  data for fifteen situations. Four curves, figures C-2 through C-5 have been prepared from these data. The table expresses a modified version of equation (1.1):

$$\Delta R_0 = [E_1(\mu_0 d_0) + a \exp(-\mu_0 d_0)] [E_1(\mu_0 h) + a \exp(-\mu_0 h)]^{-1} \quad (1.1.a)$$

This equation was programmed and solved on an RCA 301 computer. A modification of Newton's Approximation was devised to solve the equation as a root locus problem. Although it was expected that

the curves would be exponential in asymptotic form, positive control over the problem was attained by treating it as a root locus problem. Equation (1.1.a) was then solved for the following range of variable and parameters:

Photon energy	.661 Mev.
Total attenuation cross section	.003048(.003048 exp(-457xAlt.)).002657, ft. <sup>-1</sup>
Reference plane altitude	0.0(500.)3000.0, ft.
Relative detector height	3.0, 30.0, ft.
Percent contribution	.9385(x.741).003188

Equation (1.1.a) was divided into two parts:

$$Y_1 = E_1(\mu_0 d_0) \quad (1.1.b)$$

$$Y_2 = \Delta R_0 \sqrt{E_1(\mu_0 h)} + a e^{-\mu_0 h} - a e^{\mu_0 d_0} \quad (1.1.c)$$

The large number of iterations required for solution (i.e., slow convergence) was due to the behavior of the first derivatives of the right members of equations (1.1.b) and (1.1.c) with respect to distance.

The program was organized such that in any one run any finite number of desired roots can be computed. The root is computed to an accuracy defined by two constraints:

$$|Y_1 - Y_2| \leq .001$$

$$\Delta d_0 = .00067d_0.$$

The field strength (in roentgens per hour) due to fallout at a distance greater than  $d_0$  is obtained by substituting  $d_0$  for  $h$  in equation (1.1).



TABLE C-1

Percent contribution to the CRFS,  $\Delta R_0$ , due to radioactive fall-out as a function of distance greater than a specified distance,  $d_0$ .

NOTES:	(1) Homogeneous fall-out distribution on an infinite smooth plane, photon energy .661 Mev.										(2) $\Delta R_0$	
SYMBOLS:	Alt. - Altitude of fallout plane above sea level, ft.					$\mu_0$ - Total attenuation cross section					$\Delta R_0$	$d_0$
Alt	0.0	500.0	1000.0	1000.0	1500.0	2000.0	2500.0	3000.0	3500.0	4000.0		
$\mu_0$	.003048	.002979	.002912	.002917	.002846	.002782	.002719	.002657	.002597	.002538		
h	3.0	3.0	3.0	6.0	3.0	3.0	3.0	3.0	3.0	3.0		3.0
$\Delta R_0$	$d_0$	$d_0$	$d_0$	$d_0$	$d_0$	$d_0$	$d_0$	$d_0$	$d_0$	$d_0$	$\Delta R_0$	$d_0$
1.0	3.0	3.0	3.0	6.0	3.0	3.0	3.0	3.0	3.0	3.0	1.0	3.0
.9485	4.0303	4.0351	4.040	7.788	4.045	4.050	4.055	4.060	4.064	4.068	.9485	4.068
.7028	15.575	15.685	15.795	25.493	15.907	16.019	16.131	16.245	16.360	16.475	.7028	16.475
.5208	41.631	42.109	42.590		43.078	43.363	44.071	44.574	45.085	45.600	.5208	45.600
.3859	84.896	86.137	87.396		88.674	89.970	91.285	92.618	93.972	95.340	.3859	95.340
.2860	143.36	145.37	148.21		150.70	151.21	155.79	158.41	161.07	163.70	.2860	163.70
.2119	211.77	217.06	221.01		223.40	229.15	233.33	234.02	241.92	246.30	.2119	246.30
.1570	286.76	296.35	302.24		305.26	313.97	314.67	326.17	332.45	338.70	.1570	338.70
.1163	374.36	381.78	389.40		397.16	405.07	413.13	421.36	426.59	432.80	.1163	432.80
.08620	461.83	471.26	480.89		490.73	497.42	500.47	521.41	523.22	525.00	.08620	525.00
.06388	552.58	564.04	575.75		583.23	599.99	612.41	625.17	638.15	651.10	.06388	651.10
.04734	627.48	636.88	673.56		682.75	702.18	717.09	732.09	740.98	750.00	.04734	750.00
.03508	742.11	750.62	745.49		790.50	807.31	824.51	842.08	837.65	846.00	.03508	846.00
.02599	803.75	858.91	858.20		896.21	915.45	935.16	955.09	963.63	972.00	.02599	972.00
.01926	900.60	963.13	926.14		1000.9	1017.9	1035.7	1053.2	1038.5	1046.00	.01926	1046.00
.01427	977.82	1018.1	1047.5		1051.8	1065.2	1167.7	1175.0	1164.5	1172.00	.01427	1172.00
.01058	1064.8	1135.6	1182.0		1146.8	1148.0	1257.3	1242.1	1282.9	1282.00	.01058	1282.00
.007836	1179.5	1208.7	1182.0		1275.7	1241.7	1349.4	1297.9	1346.6	1346.00	.007836	1346.00
.005807	1251.4	1282.7	1296.8		1360.2	1363.2	1349.4	1418.2	1496.0	1496.00	.005807	1496.00
.004303	1428.7	1461.0	1366.9		1455.0	1437.7	1484.1	1488.9	1496.0	1496.00	.004303	1496.00
.003188	1525.6	1559.5	1442.1		1455.0	1517.6	1572.4	1561.6	1650.5	1650.50	.003188	1650.50

Incomplete Run.

Incomplete Run.



C-1

$\Delta R_0$ , due to radioactive  
 ce greater than a specified  
 $d_0$ .

Distribution on an infinite smooth .661 Mev. plane						(2) $\Delta R_0$ in fractional parts, $d_0$ in feet.								
$\mu_0$ - Total attenuation cross section, $\text{ft.}^{-1}$						h - Relative detector altitude above fallout, ft.								
0	1500.0	2000.0	2500.0	3000.0	3500.0	4000.0	0.0	500.0	1000.0	1500.0	2000.0	2500.0	3000.0	
312.002846	.002782	.002719	.002657	.002597		.002539	.003048	.002979	.002912	.002846	.002782	.002719	.002657	
3.0	3.0	3.0	3.0	3.0		3.0	30.0	30.0	30.0	30.0	30.0	30.0	30.0	
$d_0$	$d_0$	$d_0$	$d_0$	$d_0$	$\Delta R_0$	$d_0$	$d_0$	$d_0$	$d_0$	$d_0$	$d_0$	$d_0$	$d_0$	
3.0	3.0	3.0	3.0	3.0	1.0	3.0	30.0	30.0	30.0	30.0	30.0	30.0	30.0	
4.045	4.050	4.055	4.060	4.064	.9485	4.069	35.336	35.381	35.426	35.471	35.516	35.561	35.606	
15.907	16.019	16.131	16.245	16.360	.7028	16.475	75.236	75.779	76.325	76.876	77.431	77.990	78.554	
43.078	43.363	44.071	44.574	45.085	.5208	45.600	130.29	132.31	133.81	135.32	136.86	138.41	139.98	
88.674	89.970	91.285	92.618	93.972	.3859	95.345	198.37	201.17	204.00	206.88	209.80	212.76	214.60	
150.70	151.21	155.79	159.41	161.07	.2860	163.78	274.28	278.65	283.10	287.62	292.22	296.90	301.66	
223.40	229.15	233.33	234.02	241.92	.2119	246.34	355.95	362.09	368.34	374.48	381.20	387.80	394.53	
305.26	313.97	314.67	326.17	332.45	.1570		438.37	449.70	457.89	466.24	474.75	483.42	492.27	
397.16	405.07	413.13	421.36	426.59	.1163		530.34	540.36	550.57	561.00	569.40	582.48	593.54	
490.73	497.42	500.47	521.41	523.22	.08620		621.28	628.32	645.64	658.21	671.07	684.14	697.50	
583.23	599.99	612.41	625.17	638.15	.06388		714.02	728.20	737.68	757.43	772.50	787.93	803.58	
682.75	702.18	717.09	732.09	740.98	.04734		805.38	816.80	841.34	858.40	875.72	893.48	911.63	
790.50	807.31	824.51	842.09	837.65	.03508		904.31	922.77	941.66	960.97	980.69	1000.8	1021.3	
896.21	915.45	935.16	955.09	963.63	.02599		1001.7	1022.6	1043.6	1064.1	1081.6	1099.8	1118.1	
1000.9	1017.9	1035.7	1053.2	1038.5	.01926		1101.0	1124.0	1147.4	1171.5	1195.9	1220.9	1237.0	
1051.8	1065.2	1167.7	1175.0	1164.5	.01427		1177.7	1200.1	1222.8	1246.3	1270.1	1294.4	1362.5	
1146.8	1148.0	1257.3	1247.1	1282.9	.01058		1258.7	1278.3	1362.8	1391.0	1421.1	1450.8	1469.9	
1275.7	1241.7	1349.4	1297.9	1346.5	.007836		1351.6	1364.0	1473.9	1506.3	1539.0	1571.7	1604.4	
1360.2	1363.2	1349.4	1418.2	1496.0	.005807		1473.0	1467.1	1574.6	1609.6	1646.0	1682.6	1719.2	
1455.0	1437.7	1484.1	1488.9	1496.0	.004303		1604.5	1612.2	1676.2	1713.0	1646.0	1682.6	1719.2	
1455.0	1517.6	1572.4	1561.6	1650.5	.003188		1700.9	1738.2		1816.7	1804.9	1841.7	1877.6	

Incomplete Run.

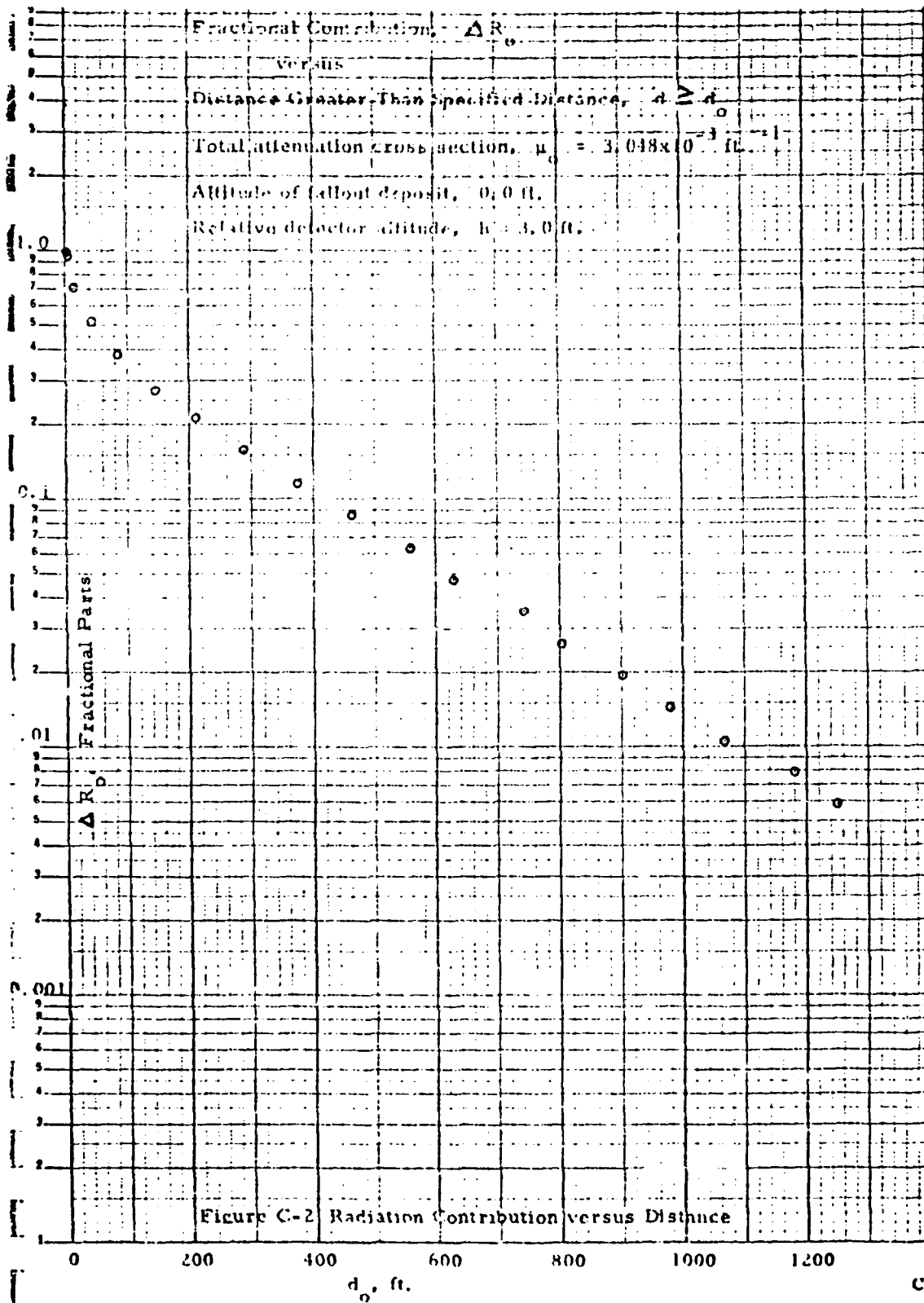

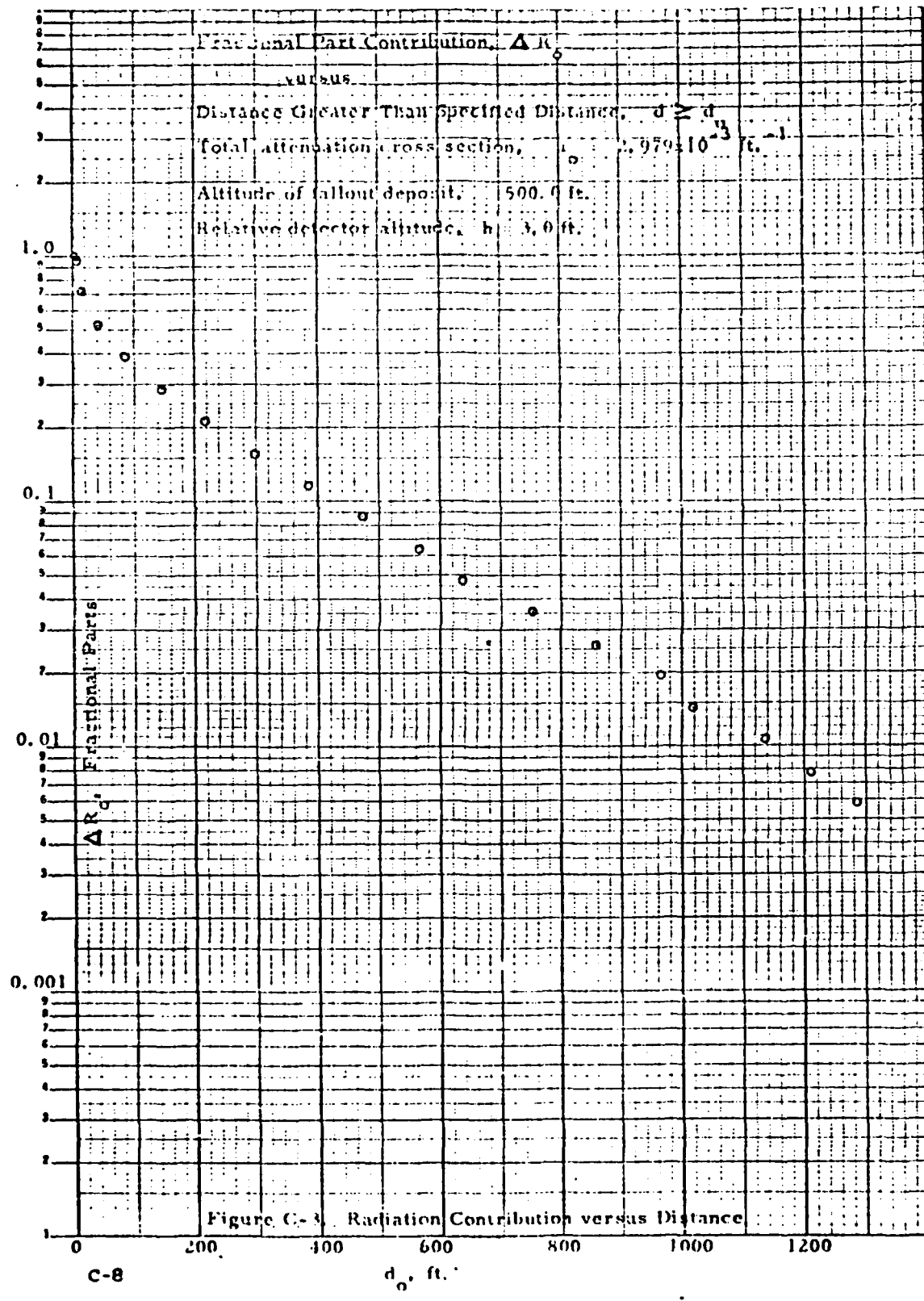

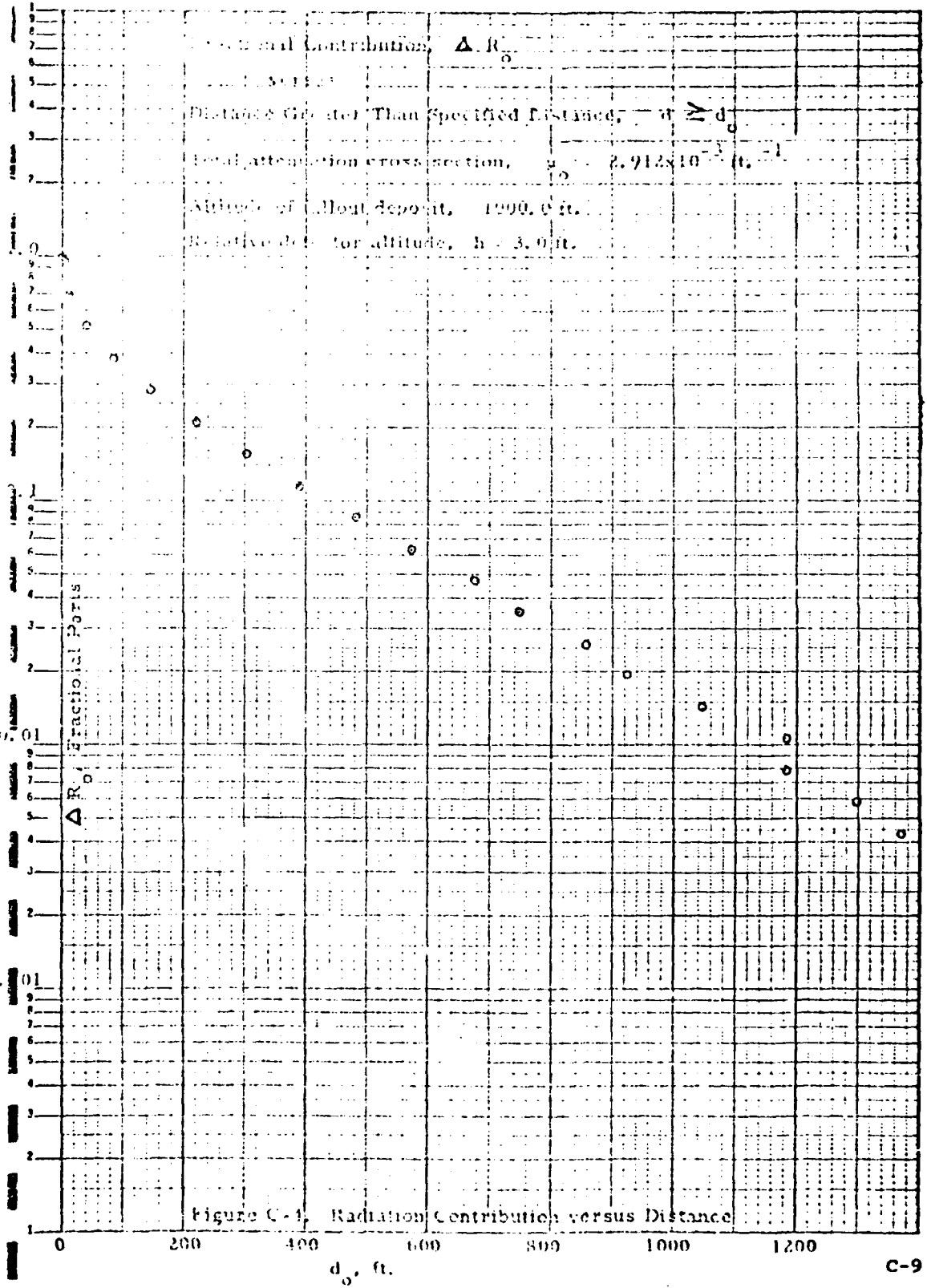
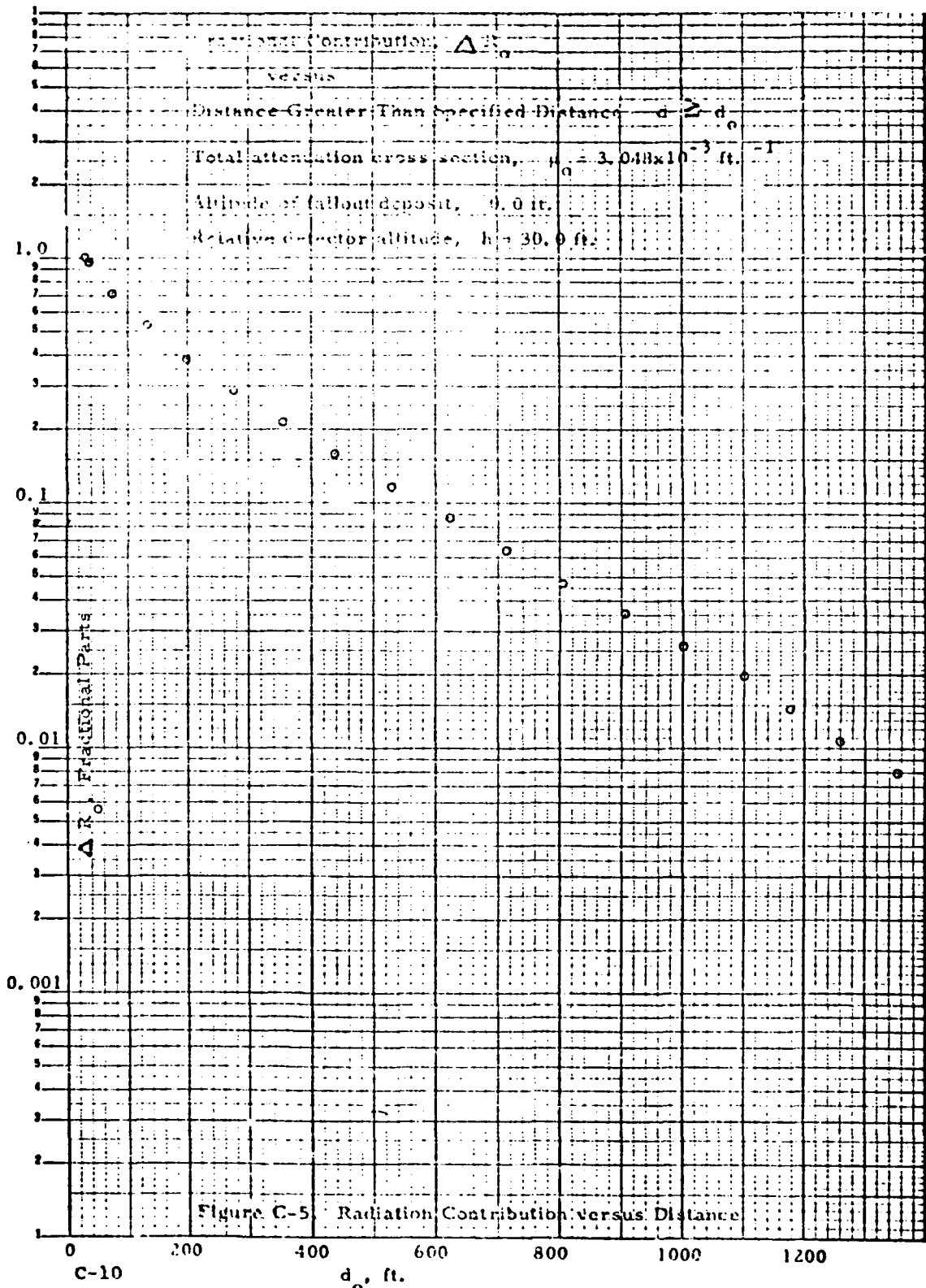

Figure C-1. Radiation Contribution versus Distance



C-10

$d_o$ , ft.

## 1.2 The Influence of Small Scale Effects on the Basic Gamma Radiation Field.

The inclusion of small scale effects in the idealized case causes equation (1.1) to be invalid. Merely the inclusion of surface roughness requires that the gamma radiation field strength be described by

$$R_g = 2 \pi K S \left[ E_1(\mu_o h + \delta \mu_e) + (a \mu_o h \exp(-\mu_o h - \delta \mu_e)) / (\mu_o h + \delta \mu_e) \right] \quad (1.2)$$

where  $\delta$  is the root mean square (rms) thickness of the roughness and  $\mu_e$  is the absorption cross section of the roughness.

The gamma radiation field strength contribution due to an  $i^{\text{th}}$  perturbation is described by

$$R_i = K \sum_{ij} S_{ij} (1 + a \mu_o d_{ij}) e^{-(\mu_o + \mu_e d_{ij}/h_i) d_{ij}} d_{ij}^{-2} A_{ij} \quad (1.3)$$

where  $S_{ij}$  is the perturbed fallout distribution over the area  $A_{ij}$  (see figures C-6 and C-7). The total field strength actually measured is then described by evaluating equation (1.3) for all the perturbations present within a prescribed distance,  $d_o$ , of the monitoring point:

$$R_s = K \sum_i \sum_j S_{ij} (1 + a \mu_o d_{ij}) e^{-(\mu_o + \mu_e d_{ij}/h_i) d_{ij}} d_{ij}^{-2} A_{ij} \quad (1.4)$$

The specific intensity,  $K$ , is independent of both large and small scale perturbations, depending only on weapon characteristics and detonation altitude.  $h_i$  is the normal distance of the detector from the reference plane (with respect to the  $i^{\text{th}}$  perturbation). Figures C-2 through C-5 are used to determine  $d_o$ . (The curve to be used for any particular case is determined by the location of the monitoring point.)

The curves of  $\Delta R_o$  vs  $d_o$  are a conservative estimate of the distance from a detector a given fractional contribution may be generated, and therefore may be used as a guide in determining how far away a perturbation source must be in order that the detected perturbation be less than a given limit. A more accurate value of  $d_o$  can be obtained by solving a modified form of equation (1.2):

$$\Delta R_e = \frac{E(\mu_o d_o + \int \mu_o d_o / h) + a \mu_o h (\mu_o h + \delta \mu_e)^{-1} e^{-(\mu_o + \delta \mu_e / h) d_o}}{E(\mu_o h + \delta \mu_e) + a \mu_o h (\mu_o h + \delta \mu_e)^{-1} e^{-(\mu_o h + \delta \mu_e)}}$$

The  $\Delta R_o$  curves can be used for guidance to solve equation (1.2a) directly instead of using root locus.  $\mu_e$  would be a parameter of the solution process with an approximate range extending from 0.5 by multiples of 1.35 up to approximately 50.0 ft.<sup>-1</sup> and  $\int$  would also be a parameter with a range extending from 0.0001 by multiples of 1.45 up to approximately 0.1 ft.

The unperturbed gamma radiation field strength at any monitor point as described by equation (1.1) can also be represented in a form  $R_{oi}$  which provides for the selection of different fallout distributions,  $S_i$ , and different relative detector heights,  $h_i$ :

$$R_{oi} = 2\pi K S_i \left[ E_1(\mu_o h_i) + a \exp(-\mu_o h_i) \right] \quad (1.5)$$

The percent change in field strength due to any single small scale effect,  $\Delta R_{si}$ , is then readily obtained by combining equations (1.3) and (1.5):

$$\Delta R_{si} = \Delta R_i - \Delta R_{oi}$$

$$\Delta R_{oi} = K S_i \left( \sum (1 + a \mu_o d_{ijo}) e^{-\mu_o d_{ijo}} d_{ijo}^{-2} A_{ijo} \right) R_{oi}^{-1} \quad (1.6)$$

where

$$d_{ijo} = \sqrt{r_{ij}^2 + h_o^2}$$

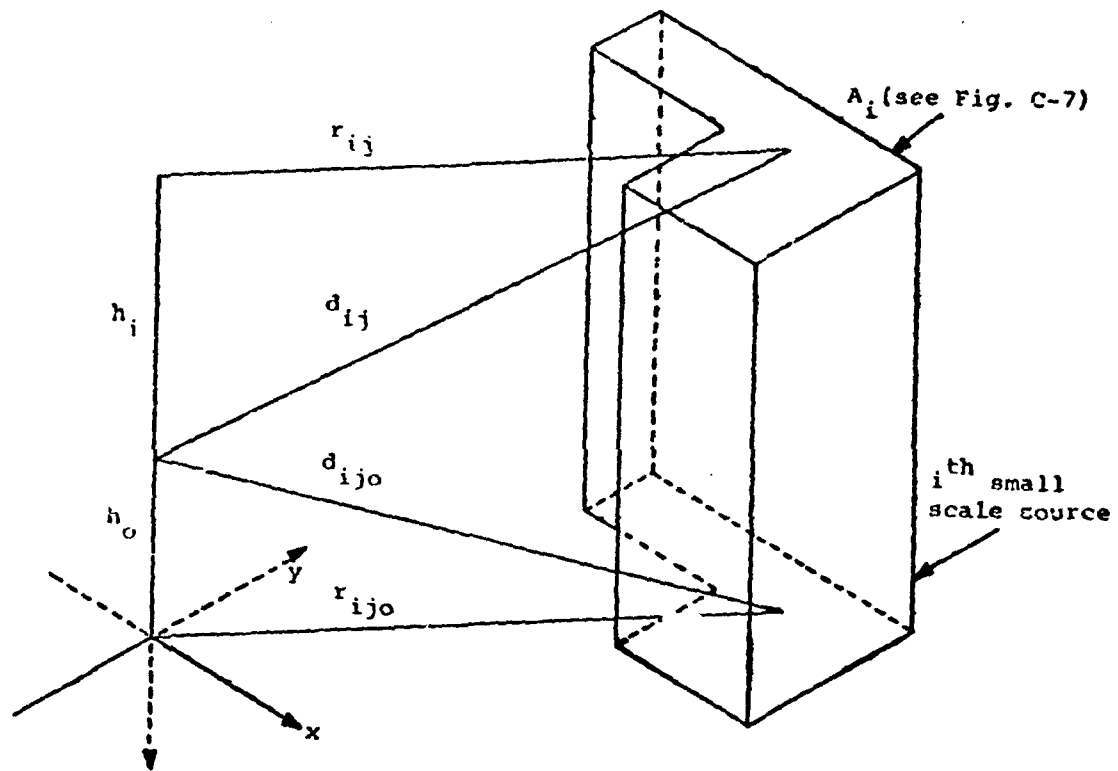

Figure C-6. Typical Small Scale Source Geometry

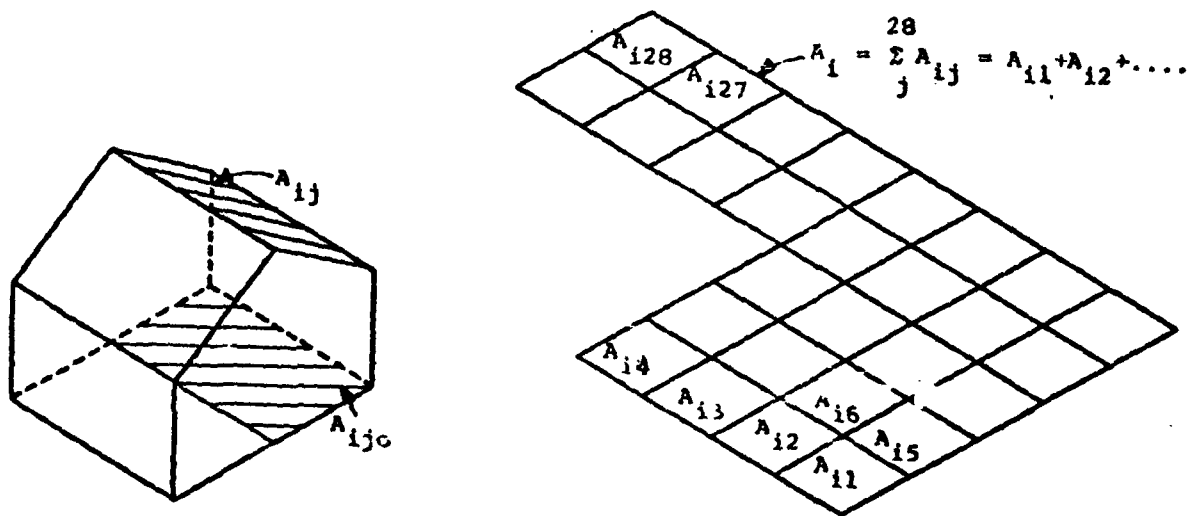

Figure C-7. Details of Source Geometry

$h_0$  is the nominal relative detector height,  $\sum_j A_{ij0}$  is the area of the  $i^{\text{th}}$  perturbation projected on the reference plane (see fig. C-7), and

$$\Delta R_i = R_i / R_{0i}$$

The percent change in the field strength due to a selected combination of small scale effects,  $\Delta R_s$ , is then obtained by summing equation (1.6) over all the independent perturbations:

$$\Delta R_s = \sum_i \Delta R_{si} = \sum_i (\Delta R_i - \Delta R_{0i}) \quad (1.8)$$

The distinction between individual small scale effects and independent perturbations is that an independent perturbation is composed of all the small scale effects generated at a specific location.

The effects are expressed in terms of the change in the gamma radiation field strength due to small scale sources. Explicitly, (a) the change in the field strength due to a single small scale source,  $\Delta R_{0i}$ , is described by equation (1.6).

The measured value is then given by

$$R_{si} = R_0 \Delta R_{si} = R_0 (\Delta R_i - \Delta R_{0i})$$

for one source, and by

$$R_s = R_0 \Delta R_s = R_0 \sum_i \Delta R_{si}$$

for a selected combination of sources.

The need to correct a measurement of the field strength at one height,  $h_k$ , to the measurement at a pre-determined height,  $h_1$ , yields the relation

$$R_s(h_1) = \Delta R_h R_s(h_k)$$

where  $\Delta R_h$  is the height correction coefficient having the general form

$$\Delta R_h = R_o(h_1)/R_o(h_k)$$

where  $R_o$  is given in equation 1.1.

If  $h_1$  is three feet and  $h_k$  is thirty feet the correction factor is 1.7.

The variation of small scale effects also depends on detector height. Equation (1.3) is used in integral form to express the change in variation of small scale effects as a function of difference in detector height. (Shielding effects have been neglected.)

$$\Delta R(\Delta h) = \frac{\Delta R_i(h_k)}{\Delta R_i(h_1)} = \frac{R_i(h_k)R_o(h_1)}{R_i(h_1)R_o(h_k)} \quad (1.12)$$

$$\begin{aligned} R_i(h_k) &= \int_A S(r) (1+a\mu_o d) s^{-(\mu_o + \int \mu_e / h_{ik}) d} d^{-2} dA \\ &= \int_{r=0}^{r=r_o} S(r) (1+a\mu_o d) e^{-(\mu_o + \int \mu_e / h_{ik}) d} d^{-2} dA \\ &\quad + 2\pi KS_o \left[ E_1(\mu_o d_{ok} + \int \mu_e d_{ok} / h_{ok}) \right. \\ &\quad \left. \frac{+ a \mu_o h_{ok} e^{-(\mu_o + \int \mu_e) d_{ok}}}{(\mu_o h_{ok} + \int \mu_e h_{ok})} \right] \end{aligned} \quad (1.12.a)$$

$$\begin{aligned} R_i(h_1) &= \int_{r=0}^{r=r_o} S(r) (1+a\mu_{od}) e^{-(\mu_o + \int \mu_e / h_{i1}) d} d^{-2} dA \\ &\quad + 2\pi KS_o \left[ E_1(\mu_o d_{o1} + \int \mu_e d_{o1} / h_{o1}) \right. \\ &\quad \left. + \frac{a \mu_o h_{o1} e^{-(\mu_o + \int \mu_e / h_{o1}) d_{o1}}}{(\mu_o h_{o1} + \int \mu_e d)} \right] \end{aligned} \quad (1.12.b)$$

$\Delta R(\Delta h)$  is the change in small scale effect variation. The perturbation of fallout is restricted to an area of radius to below the detector, and  $h_k$  is assumed larger than  $h_1$ .  $d_{ok}$  and  $d_{o1}$  are defined by the Pythagorean Theorem:

$$d_{ok} = \sqrt{r_o^2 + h_k^2}$$

$$d_{o1} = \sqrt{r_o^2 + h_1^2}$$

Hence  $d_{ok}$  is larger than  $d_{o1}$ .  $R_o(h_k)$  and  $R_o(h_1)$  are given by equation (1.1) (substituting  $h_k$  and  $h_1$  for  $h$ ). The ratio  $R_o(h_1)/R_o(h_k)$  is the correction for the change in total measured intensity due to a change in detector height, and has no effect on the change in small scale effects variation. The ratio  $R_i(h_k)/R_i(h_1)$  expresses the change in small scale effects variation as a function of detector height. Examination of equations (1.12.a) and (1.12.b) yields the conclusion that as detector height increases the influence of small scale sources on the measured field strength decreases.

However, the detector measures only ionization due to gamma radiation and the measured value does not provide any information about the actual fallout distribution. The ionization at the detector is the result of the idealized fallout distribution (fallout deposited as a result of attack pattern, soil composition at ground zero, meteorological conditions, burst heights, and weapons characteristics) perturbed by small scale sources. Consequently, there exists some optimal height for detector placement that minimizes small scale effects variation yet does not cause the detector to sense ionization from an unduly large area of idealized fallout distribution. This height probably exceeds 30 ft.; however, it is not feasible to install large numbers of sensors at greater heights.

The data of figure IV-18 can be used to gain some quantitative information about the change in small scale effects variation due to a change in detector height. One perturbation shape will be used - a variation in fallout in a circular area directly below the detector. Since the fallout contribution to the measured field strength is governed primarily by the inverse square law a perturbation directly under the detector is the worst case. All the fallout will be assumed to lie in a single plane. Two perturbations in the disturbed fallout area are established by first doubling the fallout in a circle, and then eliminating it. Also, the perturbation is applied to two different sizes of area. The intensity ratios resulting from these variations are given in figure IV-18 relative to an unperturbed intensity of unity. The given ratios are the bounds for any perturbation within the specified limits of fallout perturbation amount and area.

Based on the study of available small scale effects data, it is considered reasonable to assume that 90% of the fallout perturbations are not greater than a doubling or elimination of fallout in a specified area.

Analyses of this type can be extended to a larger area or a larger number of perturbations. Only a finite amount of fallout is deposited, hence the increase in fallout in a specified area must be accompanied by a decrease elsewhere, and vice versa.

### 1.3 Predictable and Random Small Scale Effects.

Two categories of small scale influences and effects may be considered:

a. Predictable small scale effects are those due to fixed small scale influences, such as terrain, buildings, etc. The gamma

radiation field strength perturbation due to fixed small scale influences can be predicted for any specific monitor point to some degree of accuracy.

b. Random small scale effects cannot be predicted in advance. They are due to small scale influences that are not fixed with respect to a specific monitor point. Random small scale effects are caused by influences such as wind and other weather variations. Conceptually, various hypothetical situations can be devised to simulate random small scale effects, and then experiments and/or computations can be performed which would lead to appropriate probability distributions.

Some monitoring points will have small scale effects probability distributions that have negligible variance. These distributions are known as "delta functions" (fig. C-8). They arise from the fact that nearly all small scale effects at such monitoring points are predictable. An example of such a monitoring point is the center of a flat, circular, 100 acre lawn.

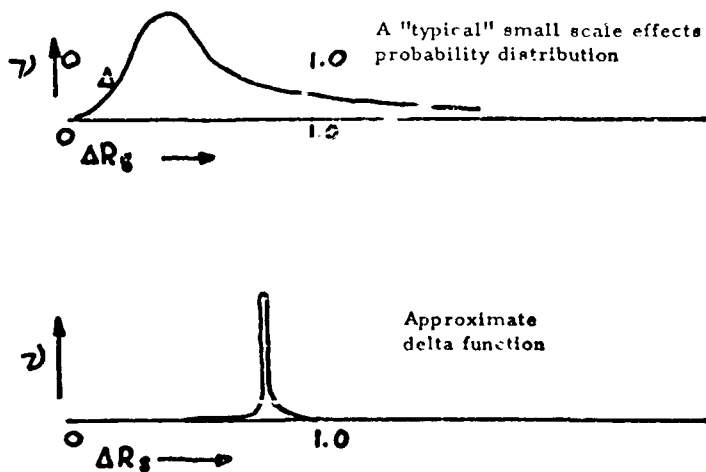

Figure C-8. Probability Distributions

1.4 The Direct and Scattered Gamma Flux Components of the Basic Gamma Radiation Field.

Gamma flux is composed of two components; the direct flux,  $F_d$ , and the scattered flux,  $F_s$ . Mathematically

$$R(\ ) = F_d + F_s \quad (1.9)$$

where the subscripted parenthesis indicate that this expression is true for all fallout distribution. The two components of the unperturbed gamma radiation field are readily determined from equation (1.1):

$$F_d = 2\pi K S E_1(\mu_o h) \quad (1.9.a)$$

$$F_s = 2\pi K S a \exp(-\mu_o h) \quad (1.9.b)$$

Shielding could be used underneath the detector to eliminate detector response to direct radiation flux. This shielding would also screen out a considerable portion of the scattered flux. Gamma scattering diagrams<sup>(2)</sup> for proton energies characteristic of the gamma radiation field permit the scattered flux to be divided into two parts (to a first order approximation), each part described by

$$\begin{aligned} F_{sd} &= 0.4 F_{su} \\ &= \frac{4}{7} \pi K S a \exp(-\mu_o h) \end{aligned} \quad (1.10)$$

where  $F_{sd}$  is the flux scattered downward to the detector, and  $F_{su}$  is the part scattered upward into the detector. Hence, the use of  $2\pi$  steradians of shielding underneath the detector would produce a flux of

$$R_o = 2\pi K S \left[ T E_1(\mu_o h) + (2+5T) \frac{ae^{-\mu_o h}}{7} \right] \quad (1.11)$$

where  $T$  is the transmission of the shield.

When the gamma radiation field is modified by small scale effects the gamma flux cannot be described by equations (1.9.a),

(1.9.b), (1.10), and (1.11). The mathematical description of the direct and scattered components of  $R_s$  must be obtained from equation (1.4).

It is believed that influence of small scale effects on measurements can be at least partially controlled through the use of scattered radiation. Assume that the gamma radiation field strength at some arbitrary field point,  $P_0$ , is measured with a highly directional detector on a plane with a non-homogeneous fallout distribution (radiating only gammas) along an arbitrary azimuth. It would yield a plot of the energy detected,  $R_v(\theta)$ , such as that given in figure C-9A, if atmospheric scattering were not present. When the detector is not pointed at the plane,  $R_v$  is zero.<sup>(3)</sup>

If the atmosphere had increasingly large scattering cross sections,  $\sigma_1$ ,  $\sigma_2$  and  $\sigma_3$ , a negligible absorption cross section, and constant density, measuring the field strength at  $P_0$  would result in curves such as those of figures C-9B, C-9C, and C-9D.

Comparison of figures C-9A through C-9D indicates that if only the scattered component of a gamma radiation field is measured the directional influence of a small scale source on that radiation field is smaller than the directional influence on the total gamma flux.

The moderating effect of scatter suggests that detectors should be shielded from all practical fallout deposition surfaces to reduce the sensitivity of the measured gamma radiation field strength to small scale effects.

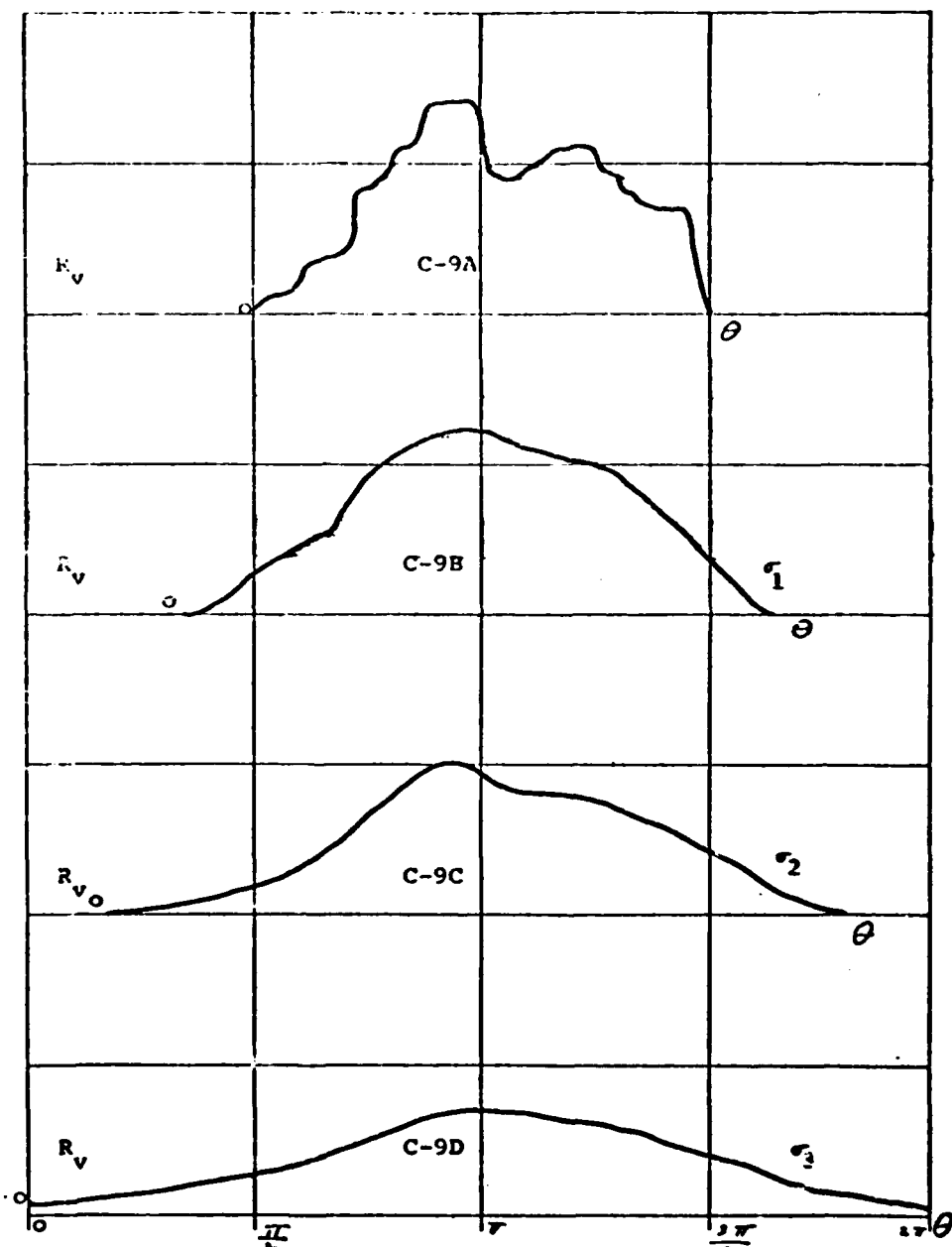

Gamma Radiation Field Strength,  $R_V$ , versus Collimated Detector Elevation Angle,  $\theta$ , at Constant Azimuth Non-Homogeneous Fallout Distribution

Notes:

Figure C-9. Directional Detector Output

### 1.5 Statistical Analysis of Small Scale Effects.

The statistical analysis of small scale effects relates to the extraction of distribution information from experimental data. Data of the type found in Reference (4) are suitable for the statistical evaluation of small scale effects.

Table C-2 and the histogram of figure IV-17 represent the - results of applying statistical analysis to the available experimental data (the nine unsheltered detectors of Owen and Sartor).

Data for this type of analysis must include not only the measured values of either the intensity or the perturbed fallout distribution, but must include also information about the unperturbed distribution.

TABLE C-2  
SMALL SCALE EFFECTS FREQUENCY DISTRIBUTION

<u>Interval Boundary</u>	<u>Interval Mean Value</u>	<u>Relative Frequency</u>	<u>Interval Boundary</u>	<u>Interval Mean Value</u>	<u>Relative Frequency</u>
.2147	.2449	.0013	.8175	.8379	.0539
.2751	.3038	.0067	.8583	.8798	.0444
.3326	.3600	.0256	.9012	.9238	.0309
.3874	.4135	.0471	.9463	.9700	.0323
.4396	.4644	.0592	.9936	1.0185	.0202
.4893	.5129	.0997	1.0433	1.0694	.0134
.5366	.5591	.1226	1.0955	1.1229	.0229
.5817	.6031	.0822	1.1503	1.1790	.0134
.6246	.6450	.0566	1.2078	1.2380	.0161
.6654	.6843	.0471	1.2682	1.2999	.0148
.7044	.7229	.0525	1.3316	1.3649	.0107
.7415	.7600	.0404	1.3982	1.4331	.0107
.7785	.7980	.0646	1.4681	1.5048	.0040
			1.5415	1.5800	.0053

#### REFERENCES

- (1) Evans, E. D. The Atomic Nucleus. 1955. McGraw-Hill.
  - (2) Condon, E. U., and Odishaw, H. Handbook of Physics. McGraw-Hill Publishing Company: N. Y. 1958. pp. 9-117.
  - (3) Mather, R. L. et al. Operation Teapot. WF-1225. Project 2.3b. 10/28/63.
  - (4) Owen, W. L., and Sartor, J. D. Radiological Recovery of Land Target Components - Complex I and Complex II. U. S. Naval Radiological Defense Laboratories. San Francisco, California. 1962.
- Bloide, A., Read, R., and Shepard, R. "Prediction, Monitoring, and Estimation of Fallout Patterns for Civil Defense." UCLA-IER Rpt. 2-17, 8/1/59.
- Corcos, G. M. On the Small-Scale Non-Homogeneity of Fallout Deposition. University of California Institute of Engineering Research. Rpt. S2, I2. Berkeley, California. 1958.
- Davis and Reinhardt. Extended- and Point-Source Radiometric Program. CEX-60.3. USAEC Rpt. 8 August 1962.
- Ford Instrument Company. Fallout Predictor. Contr. DA-36-039 SC-78185. Qtr. Rpt. #5. 1960.
- Miller, C. F. Fallout and Radiological Consequences; (Part 2). The Distribution of Fallout Particles Following a Nuclear Detonation. Postattack Research Division. Office of Civil Defense. June 1962.
- Rapp, R. P. A Mathematical Model of the Phenomenon of Radioactive Fallout. Rand Corp. Rpt. P-882-AEC. 1956.
- Read, R. R. Technique for Designing and Employing a Radiological Monitoring System for the Event of Attack. University of California. Institute of Engineering Research. Civil Defense Research Project Rpt. S2, I22. 10 April 1959.
- Thorntwaite, Mather, and Nakamura. SCIENCE. Vol. 131, 1962, p. 1051.