

UNCLASSIFIED

AD NUMBER

AD413158

LIMITATION CHANGES

TO:

Approved for public release; distribution is unlimited. Document partially illegible.

FROM:

Distribution authorized to U.S. Gov't. agencies and their contractors;
Administrative/Operational Use; JUL 1963. Other requests shall be referred to Defense Advanced Research Projects Agency, ASBD-TIO, 675 North Randolph Street, Arlington VA 22203-2114.
Document partially illegible.

AUTHORITY

RSIC (Redstone Darpa Office) Itr, 5 Jan 1966

THIS PAGE IS UNCLASSIFIED

UNCLASSIFIED

413158

AD

DEFENSE DOCUMENTATION CENTER

FOR

SCIENTIFIC AND TECHNICAL INFORMATION

CAMERON STATION, ALEXANDRIA, VIRGINIA



UNCLASSIFIED

NOTICE: When government or other drawings, specifications or other data are used for any purpose other than in connection with a definitely related government procurement operation, the U. S. Government thereby incurs no responsibility, nor any obligation whatsoever; and the fact that the Government may have formulated, furnished, or in any way supplied the said drawings, specifications, or other data is not to be regarded by implication or otherwise as in any manner licensing the holder or any other person or corporation, or conveying any rights or permission to manufacture, use or sell any patented invention that may in any way be related thereto.

**BEST
AVAILABLE COPY**

413158
CATALOGED BY DDC
AS AD No. 7
413158

ARPA ORDER NO. 347-63
PROJECT CODE NO. 7400

GENERAL MOTORS CORPORATION

TECHNICAL REPORT
ON

MILLIMETER WAVELENGTH FOCUSED PROBES AND
FOCUSED, RESONANT PROBES FOR USE
STUDYING IONIZED WAKES BEHIND HYPERSONIC
VELOCITY PROJECTILES

SPONSORED BY
ADVANCED RESEARCH PROJECTS AGENCY
U.S. ARMY MISSILE COMMAND
ARPA ORDER NO. 347-63

DDC
AUG 12 1963
TISIA B

CONTRACT NO. DA-04-495-ORD-3567(Z)
HYPERVELOCITY RANGE RESEARCH PROGRAM

GM DEFENSE RESEARCH LABORATORIES

SANTA BARBARA, CALIFORNIA



AEROSPACE OPERATIONS DEPARTMENT



TR63-217C

JULY 1963

NO. OTS

ARPA ORDER NO. 347-63
PROJECT CODE NO. 7400

Copy No. 28

GENERAL MOTORS CORPORATION

TECHNICAL REPORT
ON

MILLIMETER WAVELENGTH FOCUSED PROBES AND
FOCUSED, RESONANT PROBES FOR USE
IN STUDYING IONIZED WAKES BEHIND HYPERSONIC
VELOCITY PROJECTILES

R.I. PRIMICH AND R.A. HAYAMI

THIS RESEARCH WAS SUPPORTED BY THE
ADVANCED RESEARCH PROJECTS AGENCY
AND WAS MONITORED BY THE
U.S. ARMY MISSILE COMMAND,
REDSTONE ARSENAL, ALABAMA,

GM DEFENSE RESEARCH LABORATORIES

SANTA BARBARA, CALIFORNIA



AEROSPACE OPERATIONS DEPARTMENT

CONTRACT NO. DA-04-495-ORD-3567 (Z),
HYPERVELOCITY RANGE RESEARCH PROGRAM

TR63-217C

JULY 1963

FOREWORD

This report is one of a series of related papers covering various aspects of a broad program to investigate the flow-field variables associated with hypersonic-velocity projectiles in free flight under controlled environmental conditions. This research is being conducted in the Flight Physics Range of General Motors Defense Research Laboratories, and is supported by the Advanced Research Projects Agency under Contract No. DA-04-495-ORD-3567 (Z). It is intended that this series of reports, when completed, shall form a background of knowledge of the phenomena involved in the basic study and thus aid in a better understanding of the data obtained in the investigation.

The material in the present report was originally presented as a paper at the Millimeter and Submillimeter Wavelength Conference at Orlando, Florida in January 1963. The work described was partially supported by ARPA under the above contract, but related company-funded research work conducted at GM Defense Research Laboratories is also described in this report.

ABSTRACT

Strongly focused microwave beams are being used as a plasma diagnostics tool in the determination of the magnitude and spatial distribution of ionization behind projectiles fired at hypersonic velocities into the controlled atmosphere of a flight physics range. The importance of millimeter wavelength techniques for this purpose is stressed. The design philosophy of focused plasma probes is outlined and specific details of 35 and 70 Gc probes are given, together with some typical results. The conversion of such a probe into a free-space resonator in which the resolution is preserved, but in which the sensitivity is greatly improved, is discussed and some preliminary results are given.

TABLE OF CONTENTS

Section		Page
	Foreword	ii
	Abstract	iii
I	Introduction	1
II	Theory of the Focused Probe	3
	Background	3
	Focused Antenna	7
	Microwave Circuitry	8
	Theory of Interaction of Plane Waves with Plasmas	12
III	Equipment Details	18
	Selection of Operating Frequency	18
	Focused Antennas	21
	Overall System Description	27
	Calibration	32
	Range Installation of Focused Probes	35
	Results Obtained with Focused Probes	35
IV	Focused Resonant Probes	43
	References	50

LIST OF ILLUSTRATIONS

Figure	Title	Page
1	Transverse Focused Microwave Probe	6
2	35 Gc Probe Capability. Far Wake	19
3	Focusing Lens	22
4	Amplitude Distribution in Focal Plane	24
5	Phase Distribution in Focal Plan	25
6	70 Gc Probe Resolution Measurements	26
7	Off-Axis Scanning Properties of the Focusing Lens	28
8	Ideal Disposition of Focused Microwave Beams Across a Hypersonic Wake	29
9	35 Gc Probe Circuit	31
10	Phase-Locked Calibration Circuit	34
11	70 Gc Focused Probe Module	36
12	35 and 70 Gc Probe Installation on Range	37
13	35 Gc Beam Attenuation	38
14	70 Gc Beam Attenuation	39
15	Seven-beam 70 Gc Probe. Attenuation	41
16	Seven-beam 70 Gc Probe. Phase Shift	42
17	Proposed Focused Resonator	45
18	Alternate Form of Focused Resonator	45
19	Focused Resonator. Typical Results, Amplitude vs Frequency	46
20	Focused Resonator. Typical Results	48
21	Photograph of Focused Resonator	49

SECTION I INTRODUCTION

Wakes behind hypersonic-velocity projectiles in various atmospheres are of interest for a number of reasons. In particular, the ionized wake is important in radar tracking of such vehicles, whereas the near wake is important in evaluating the performance of communication systems which are operated through the rearward aspects. In any situation it is important to be able to predict the magnitude and spatial distribution of wake ionization, characterized by electron density and electron collision frequency.

The Flight Physics Range of General Motors Defense Research Laboratories (GM DRL) is currently employed in the study of flow-field observables associated with hypersonic-velocity projectiles in free flight under controlled environmental conditions. The observations include the measurement of thermal radiation from the body flow field and wake throughout the infrared, visible and ultraviolet parts of the spectrum, as well as direct measurement of the ionization properties of the body flow field and wake. Focused microwave probes, which are used to measure the wake ionization, will be described in this report.

Following a general outline of the method of operation, special features will be dealt with in more detail. These include the relevant properties of focused antennas, such as the spatial resolution, spatial energy

distribution near the focus, and off-axis scanning behavior; the aspects of interaction of electromagnetic waves with plasma which are applicable to the focused probe; and the circuitry required to measure the ionization parameters, including special phase-locked calibration circuits.

SECTION II

THEORY OF THE FOCUSED PROBE

BACKGROUND

The application of closed microwave cavities and non-focused free-space microwave probes to the diagnostics of ionized hypersonic wakes leads to a number of disadvantages which limit their usefulness. ^{(1)*} In general, it is difficult to interpret the results unless the radial distribution of ionization is known. Even then, the solution to a difficult electromagnetic scattering problem has to be obtained and computed. ⁽²⁾

Most of the disadvantages of the closed-cavity and non-focused probe can be overcome if a free-space system is used, in which the energy radiated from a microwave antenna is focused to produce a beam of the smallest possible physical dimensions in the neighborhood of the ionized wake. Two main benefits derive from the use of such a system, if it is properly designed. Firstly, the energy can be so well concentrated that a negligible part of it will bypass the wake; consequently the transmitted signal may be treated, with excellent accuracy, as having all passed through the region of ionization. Secondly, in the immediate neighborhood of the focal plane, the constant-phase contours are planes which are approximately parallel to the focal plane. Under these conditions the measured signal which is transmitted through the wake may be interpreted in a reasonably simple manner,

* Numbers in parentheses refer to references given at the end of this report.

since the interpretation can be based on the idealized situation of a uniform, plane wave incident normally on a plane, parallel-sided plasma slab.

It is not always possible to design an efficient focused system for any given physical situation. The results will depend on the physical dimensions of the plasma and on the magnitude of the ionization properties. On one hand, wakes with small diameters have to be studied with wavelengths so short that diffraction errors can be ignored. On the other hand, the corresponding microwave frequency has to be within at least two orders of magnitude of the plasma frequency in order that plasma effects may be measurable. However, projectile sizes in ballistic ranges which are of practical interest are such that both of the previous requirements are compatible.

Although focused antennas have been used for a number of purposes, very little success has been reported in their application to plasma diagnostics. It is believed that they have been used at the Naval Research Laboratory and at the Applied Physics Laboratory of the John Hopkins University, although no published reference to this work is known to the author. One-beam focused probes have been installed on the AVCO ballistics range but no results have been reported.⁽³⁾ More recently, interest in the focused probe has been shown among workers in the thermonuclear fusion plasma diagnostics field. Extensive use of focused systems has been proposed⁽⁴⁾ but once again no results have yet been reported. Investigations of focused systems are now underway at Princeton and it has been indicated⁽⁵⁾ that large errors have been observed in the results obtained with the use of non-focused beams.

The present work on focused probes has been a continuous effort which started at the Defence Research Telecommunications Establishment (DRTE), Ottawa, Canada, in 1956. Much of the early effort was devoted to detailed studies of the field distribution near the focus, resolution properties, and transmission through a focused system.⁽⁶⁾ Although a great deal of theoretical and experimental work on focused antennas was available in the literature, the above investigations were needed since none of the publications covered apertures of unity focal ratio, which were adopted because of their possibilities for maximum resolution. This work culminated in a four-beam system which was placed in operation on one of the ballistic ranges at the Canadian Armament, Research and Development Establishment (CARDE), in Canada.⁽⁷⁾ The circuitry of this first probe was not sufficiently sophisticated to enable unambiguous interpretation of the data to be made. However, if the wake were sufficiently underdense the probe data could be analyzed and appeared to be excellent.

The manner in which the focused probe is used in hypersonic wake diagnostics is illustrated in Figure 1. Dielectric lenses in the side walls of a two-foot-diameter section of the GM DRL Flight Physics Range are used to focus a microwave beam to the smallest possible dimensions on the flight axis. Two sets of lenses are used so that the transmission of the beam through the wake may be measured. The magnitudes of electron density and collision frequency at any instant may be deduced from the measured amplitude and phase of the transmission coefficient. The axial variation of ionization is obtained as a consequence of the fact that the wake ionization is in motion past a stationary probe. The radial variation in ionization is obtained by using several adjacent, independent beams which lie in

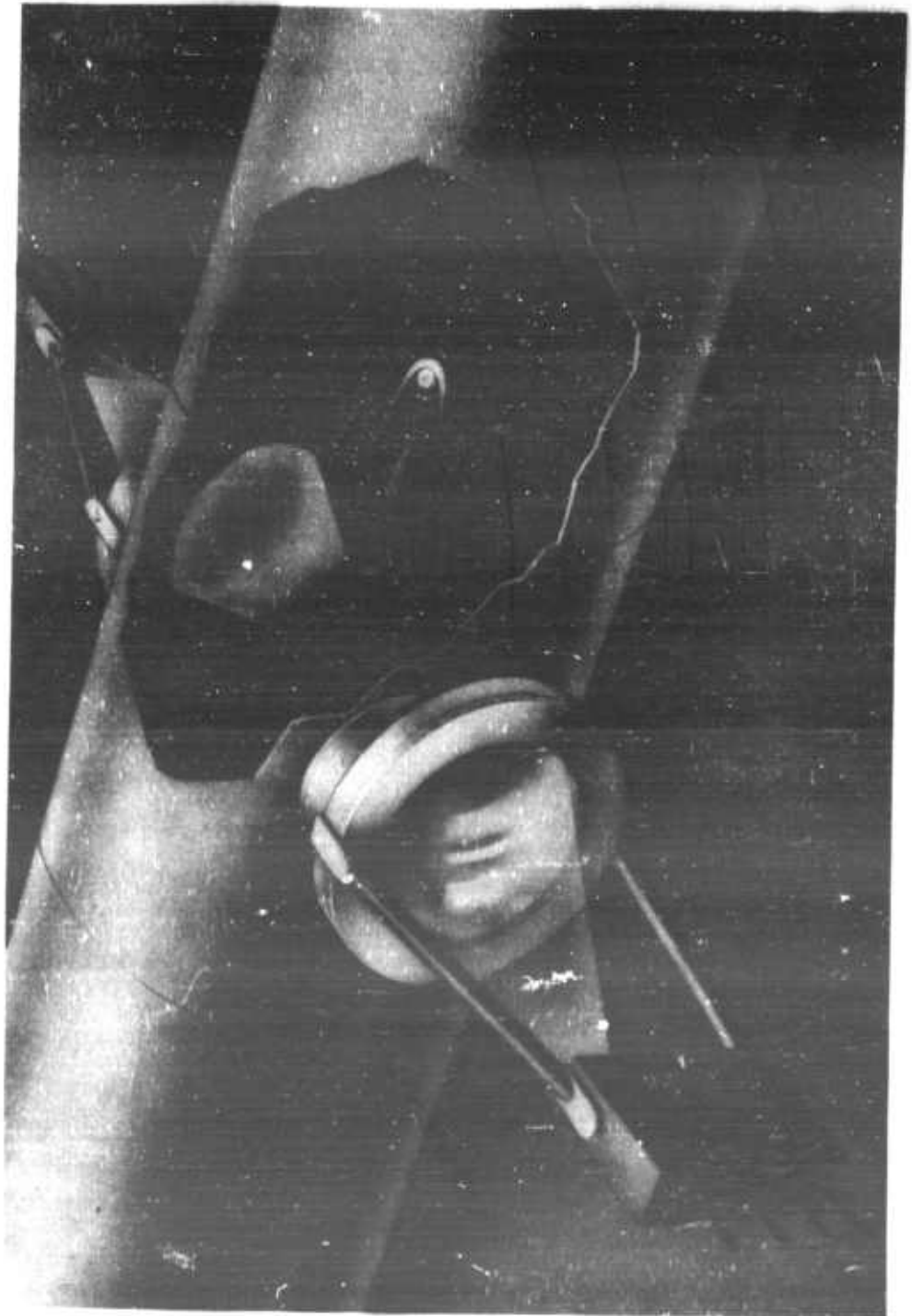

Figure 1 Transverse Focused Microwave Probe

a plane transverse to the flight axis. Each of these features will be discussed in more detail in subsequent sections of this report.

FOCUSED ANTENNA

The properties of the particular focused antennas which have been used at both DRTE and GM DRL have been described in some detail,^(1, 6, 7 and 8) and only the main features will be outlined here.

Focused apertures with focal ratios of unity have yielded virtually theoretical performance in terms of spatial resolution. In practice, this means that most of the beam energy can be transmitted through a circular area in the focal plane, the diameter of which is about two wavelengths. Alternatively, two identical targets which are located in the focal plane may be resolved, provided that they are spaced one and a half to two wavelengths apart and that the illumination over the primary aperture is suitably tapered.⁽⁹⁾

A theoretical analysis of the power flow between two focused apertures was carried out for the purpose of estimating the amount of power which could be channeled through circular areas of finite size located in the focal plane.⁽⁹⁾ It is evident from the latter results, if interference effects which arise from energy leaking around the wake are to be kept within, say, three decibels, then focused beams have to be used and the illumination over the radiating aperture has to be quite strongly tapered.

It has been found that good focusing is maintained even when the antenna feed horns are moved as much as one inch off axis. This property has been used to provide a system of several independent

beams through a single lens system. In particular, a vertical array of adjacent beams has been used to form a fence across the flight path in order to ensure interception of the ionized wake, and also to provide information on radial variations of ionization. The CARDE system,⁽⁷⁾ which is believed to be still in use, has four 35 Gc beams. Each beam is approximately one-half inch in diameter and the four beams cover a two-inch strip in the direction normal to the flight axis. Two systems are currently in use at GM DRL: one is a 35 Gc system which has seven staggered half-inch beams spaced one-quarter inch apart in the vertical direction; the other is a 70 Gc system which has seven adjacent quarter-inch beams, spaced one-quarter inch apart in the vertical direction (see Ref. 8).

MICROWAVE CIRCUITRY

The problems to be considered here are independent of the nature of the antenna field and are directly concerned with the type of circuitry that should be used to measure the desired signal parameters.

A great deal of the early plasma work was incomplete in that the measured data could not be resolved into the ionization parameters (electron density and collision frequency) without making many unjustified assumptions. For instance, many measurements have been and are being interpreted on the basis of a paper by Whitmer⁽¹⁰⁾ in which it was shown that the average electron density can be derived from the measured phase of the transmitted signal and that the collision frequency can be obtained from a measurement of the attenuation, provided that the plasma is extremely underdense.⁽⁸⁾ It is also necessary to assume that the dimensions of the plasma are known and that the ionization is uniform. These assumptions are not

always valid, however, for it has been shown ⁽⁸⁾ that the underdense approximation has a much wider range of validity and, under these conditions, the plasma parameters may be derived from a measurement of the magnitude and phase of the transmitted wave. Consequently, in future discussions it will be assumed that a microwave circuit, to be acceptable for use as a plasma probe, must at least have provisions for the measurement of both amplitude and phase of the transmitted signal.

In reality, any circuit which can be used to measure both the amplitude and phase could be considered for plasma studies. Provision has to be made for the fact that, in ballistics range work, fast transient measurement and recording of the signals is required.

A circuit which has been widely used in a variety of applications for the measurement of the magnitude and phase of the received signal is the so-called phase-quadrature circuit. The input signal in this circuit is split into two identical channels, each of which includes a mixer crystal. The crystals are fed with identical portions of the original transmitted signal, except that a 90° differential phase shift is introduced between them. This reference signal level is adjusted so that each crystal operates as a linear autodyne detector. Under these conditions, the mixer outputs are

$$A \sin \varphi \quad \text{and} \quad A \cos \varphi$$

where A is the change in signal amplitude and φ is the change in signal phase. It is evident that A and φ can be determined from the above equations.

The sensitivity of the above circuit can be improved by the introduction of an offset IF frequency, but this requires the use of IF amplifiers with exceptional phase linearity. Because of this added complexity, the simpler circuit in which the input and reference signals have the same frequency was developed at GM DRL and is now operational.⁽⁸⁾ This circuit has given excellent performance and is believed to be one of the simplest available.

Since it was recognized from the beginning that the above circuit would require fairly extensive development work, it was decided to temporarily use circuits of lesser performance, even though it was realized that the data could not be fully interpreted. It was felt that such interim data would be extremely useful as a guide to the type of signal to be expected and might also shed some light on the ionization phenomena.

One of the simplest such circuits is the one for amplitude measurements only. It has been widely used at DRTE (CARDE)⁽⁷⁾ and at GM DRL.⁽⁸⁾ Its greatest virtue is simplicity, in that only a single detector is used for each beam. The only conclusion that can be drawn from the attenuation measurement is that the amount of attenuation is due to some degree of ionization. It can be shown⁽⁸⁾ that attenuation is a function of both electron density and collision frequency, and they cannot be resolved separately without the use of additional information. Nevertheless, a great deal of data has been obtained concerning radial and axial variations of ionization.⁽⁸⁾

Another simple circuit which has been widely used is the one described by Whitmer which was mentioned earlier. In this circuit a single-channel

receiver detector is biased with a part of the transmitter signal. The output will then be of the form $A \sin \varphi$ (the notation is the same as used in a previous paragraph) and, without additional information, A and φ cannot be resolved. However, if it is assumed that there is no change in A (collision frequency neglected), then φ may be interpreted in terms of electron density. A separate amplitude measurement must be made in order to determine the collision frequency. This circuit has been used in range work⁽⁷⁾ but in many cases the data appeared to be meaningless, no doubt due to ambiguities.

A circuit which is similar to the phase-quadrature circuit in principle has been developed at the RCA Victor Co., Montreal.⁽¹¹⁾ In the RCA circuit, fixed probes are inserted in the signal waveguide for the derivation of $A \sin \varphi$ and $A \cos \varphi$. These two signals are fed into the X-Y amplifiers of an oscilloscope to give a polar display. The probes become an increasingly difficult proposition as the wavelength is decreased. It should also be noted that the polar coordinate display is not very suitable for range work unless a reliable method of tracing the direction of the trace can be found, especially when several cycles of phase shift are experienced.

Phase and amplitude measuring systems have been in use at MIT's Lincoln Laboratories⁽²⁾ for several years. These systems appear to have excellent performance in ballistic range work, but in general they include an IF loop and consequently are that much more complicated than the GM DRL system.

THEORY OF INTERACTION OF PLANE WAVES WITH PLASMAS

The interaction of an electromagnetic wave with an ionized wake will be considered in three parts. First, the geometry of the situation will be taken into account to show that the wake may be considered, to a good approximation, as a plane parallel slab in the field of uniform plane waves. Second, the desired perturbation of the wave caused by the plasma, namely attenuation and phase shift without significant deformation of the wave front, will be discussed. Finally, undesired perturbations such as refractive effects which cause serious deformation of the incident wavefront will be dealt with.

Plane Geometry Approximation

As indicated previously, the phase fronts of the incident wave are approximately plane in the vicinity of the focus. Consequently the focused field may be treated as a plane wave, provided that the size of the wake is confined to the plane phase front region. Since the amplitude distribution of the focused field in a plane of constant phase is non-uniform, the wavelength is longer than the free-space wavelength, which means that a correction would have to be applied if the focused field were regarded as a uniform plane wave. Indications^(12, 8) are that the average wavelength of the focused field is about 8% longer than the free-space value, and corrections should presumably be applied to the measured effective dielectric constant as in waveguide measurements of dielectric properties. However, a direct treatment of the problem by Northover⁽¹³⁾ has shown for an underdense plasma that the phase shift and attenuation of the focused wave after passage through a plane slab of plasma at the focus is identical to that which would be suffered by a uniform plane wave.

Since most wakes of interest are cylindrical, this case should be considered. However, it has been indicated that with strong focusing the beam size can be made significantly smaller than the wake size; under these conditions the section of wake intersected by the beam can be treated as a plane slab.

Interpretation of Transmission Coefficient

The transmission of a plane wave through a plane slab can be characterized by the transmission coefficient, T . If A_0 is the amplitude of the transmitted wave in the absence of a plasma slab and A is the corresponding amplitude in the presence of the slab, and if φ is the phase difference between these two waves, then

$$T = \frac{A}{A_0} \exp(j\varphi) \quad (1)$$

Equation (1) can be written in terms of the plasma properties and takes on a particularly simple form if the following approximation is made:⁽⁸⁾

$$\left| \frac{(\omega_p/\omega)^2}{1 - j(\nu_c/\omega)} \right| \ll 1 \quad (2)$$

Then,

$$T \doteq \exp \left[- \frac{\nu_c}{\omega} \frac{(\omega_p/\omega)^2}{1 + (\nu_c/\omega)^2} \frac{\pi}{\lambda_0} d \right] \exp \left[j \frac{(\omega_p/\omega)^2}{1 + (\nu_c/\omega)^2} \frac{\pi}{\lambda_0} d \right] \quad (3)$$

or

$$T \doteq \exp[-\alpha d] \cdot \exp[j\beta d] \quad (4)$$

where

$$\alpha = \left(\frac{\nu_c}{\omega} \right) \frac{(\omega_p/\omega)^2}{1 + (\nu_c/\omega)^2} \frac{\pi}{\lambda_0} \quad (5)$$

$$\beta = \frac{(\omega_p/\omega)^2}{1 + (\nu_c/\omega)^2} \frac{\pi}{\lambda_0} \quad (6)$$

ν_c = electron collision frequency

ω_p = angular plasma frequency

ω = angular probe frequency

λ_0 = free-space wavelength

d = plasma thickness

From a comparison of Eqs. (1) and (4), it follows that

$$\alpha d = \log_e \frac{A}{A_0} \quad (7)$$

$$\beta d = \varphi' \quad (8)$$

These equations are particularly simple, since A/A_0 and φ' are quantities that can be measured directly. The plasma parameters (ω_p/ω) and ν_c/ω may then be obtained in terms of the measured quantities, A , A_0 and φ . For example,

$$\frac{\alpha}{\beta} = \frac{\log_e \frac{A}{A_0}}{\varphi'} = \frac{\nu_c}{\omega}$$

Substitution of ν_c/ω into (5) and (7) and into (6) and (8) will determine (ω_p/ω) .

Determination of Radial Ionization Gradients

It was evident (from both 35 and 70 Gc focused-probe amplitude results) that strong radial ionization gradients appeared to exist in the wakes of projectiles of interest and that steps would have to be taken to determine these gradients. Two methods are being investigated. In the first method, ⁽⁸⁾ the transmission results obtained with an array of beams spaced in the radial direction are related to the electron density and collision frequency of a number of concentric uniform layers into which the wake is decomposed. The number of layers corresponds to the number of beams in the array, and with a sufficient number the ionization profile can be determined with adequate accuracy. In the second method, Zivanovic ^(14, 15) has attempted to solve this problem rigorously by assuming various electron density gradients with constant collision frequency in parametric form and then computing the transmission coefficient. In the case of an exponential gradient within a finite slab a rigorous solution was obtained, ⁽¹⁵⁾ but because of the higher order Bessel functions involved, which are not tabulated and cannot yet be accurately computed in a reasonable period of time, the solution was found to be of little practical value. Instead, a numerical method was developed by Zivanovic ⁽¹⁴⁾ for the purpose of computing the transmission coefficient. Detailed computations have been completed for parametric forms of both exponential and parabolic distributions of electron density within a finite slab. ^{(15)*}

*After this work was completed, a similar method ⁽¹⁶⁾ appeared in print. This latter method is a direct numerical computation of the differential equations whereas the Zivanovic method appears to be more general and flexible in that the plasma is described by matrix coefficients, which are computed. The description by matrix coefficients permits a great deal of flexibility, since more complicated cases such as composite slabs can be treated by algebraic manipulation of the matrix coefficients (see Ref. 14).

By a process of trial and error the measured transmission coefficient of each beam could be matched to some particular parabolic distribution. Computing programs are now being set up by which the radial distribution may be calculated from the measured transmission of each beam according to either method.

Refractive Effects

In the foregoing arguments it has been assumed that although a cylindrical ionized column is present in the focal region, it would not perturb the field distribution that would exist if the column were absent. These arguments have been concerned with minimization of diffraction errors and the idealization of the actual illumination in the vicinity of the plasma, all based on geometrical consideration. However, a real plasma can result in major perturbations of the focused field. The main desired perturbation is in the transmission coefficient, from which the plasma parameters may be determined. However, an undesired perturbation could be caused by refractive effects, which would result in deviative absorption, or de-focusing. Since the latter effects would be extremely difficult to interpret, it is important to determine the conditions under which refraction would be negligible.

With this in mind theoretical studies have been carried out.^(13, 17) Two distinct cases have been examined. In one case⁽¹³⁾ a finite slab of uniform plasma is located about the focal plane. It is found for an underdense plasma that the transmission coefficient is identical to that which would be obtained for uniform plane-wave incidence on the same slab. This result is remarkable in that the non-uniform nature of the incident wave and the variation of wavelength are inherent in the analysis. It is a straightforward justification of the assumption

asserted previously that the waves which propagate through the plasma are plane waves. In the second case,⁽¹⁷⁾ the effect on the transmitted wave of a uniform cylindrical column with its axis in the focal plane is determined. Closed-form solutions are obtained and can be interpreted fairly simply, either for very small cylinders or for large cylinders (say $D > 10 \lambda$). For small cylinders, the transmission coefficient can be related to the plasma properties, but not in the same way as for a slab. For large cylinders (greater than 10λ) the results reduce to those for a slab. For intermediate sizes the results are more complex, but they can be computed in any given case.

SECTION III EQUIPMENT DETAILS

SELECTION OF OPERATING FREQUENCY

The selection of frequencies is governed to a large extent by the electron densities that are to be expected in the wakes of hypersonic projectiles, fired under conditions representative of those experienced during ICBM reentry. The maximum electron densities to be expected during reentry are of the order of 10^{16-17} e/cc, and the lowest of interest are about 10^{8-9} e/cc. The corresponding plasma frequencies are of the order of hundreds of megacycles per second (10^{8-9} e/cc) to frequencies which have free-space wavelengths well into the sub-millimeter band.

Musal ⁽¹⁸⁾ has estimated electron densities in the far wake over a wide range of conditions, from which it is possible to determine the effectiveness of a particular frequency in the measurement of wake electron densities. An example of such a calculation is shown in Figure 2, in which the effectiveness of a 35 Gc probing frequency is illustrated. The maximum measurable density is determined by the condition that the plasma frequency be 35 Gc, i. e. $(N_e)_c \dagger 1.5 \times 10^{13}$ e/cc. If the underdense approximation is used, this density has to be reduced by a factor of 10. The minimum measurable density is a strong function of the sensitivity of the measuring device, and for the equipment to be described, it was found to be about 10^{10} e/cc. Additional practical experience has shown successful probe operation into the far left of

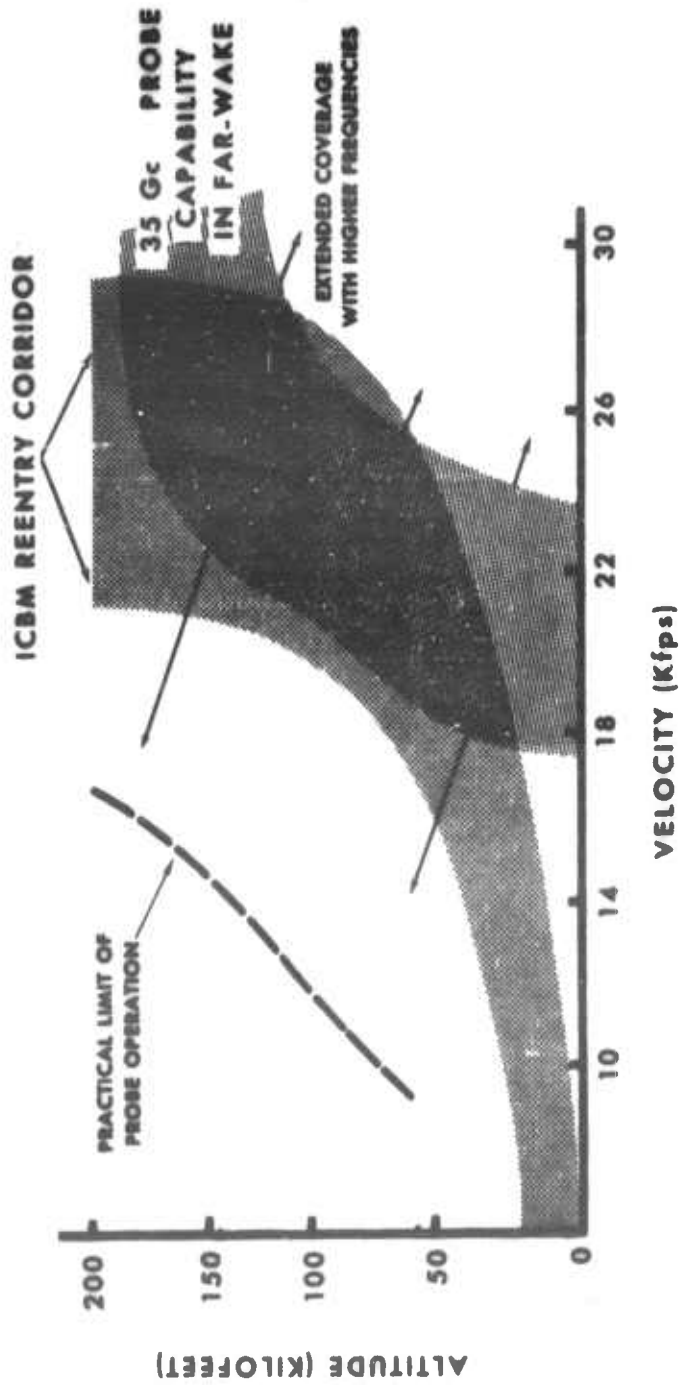

Figure 2 35 Gc Probe Capability. Far Wake

the diagram (Figure 2), which indicates that the estimates of wake densities in Reference 18 are too conservative. This is not too surprising in that Musal's analysis does not predict the diameter of the wake, nor the distance behind the projectile at which far wake conditions prevail. However, it is clear from Figure 2 that frequencies of the order of 35 Gc and higher would be extremely useful for wake studies.

The choice of frequency is also governed by the spatial resolution required, which in turn is determined by the model size. For 3/4-inch-diameter models, which are of current interest, resolutions of no more than 3/4 inch are desirable. The arguments outlined in Reference 8 lead to the conclusion that wavelengths in the millimeter range would be most useful in the production of beam dimensions of this order. For instance, a frequency of 35 Gc would result in achievable resolutions of about 1/2" to 3/4". A frequency of 70 Gc would increase these resolutions by a factor of two.

A combination of these factors leads to a selection of frequencies of 35 Gc and higher. At this time, systems have been developed at GM DRL which use 35 and 70 Gc, the precise values having been dictated by the availability of commercial equipment. Experience has shown that with this choice electron densities in the range 10^{10} - 10^{13} e/cc can be measured with ease. Trail diameters for which ionization parameters can be measured accurately are:

$$35 \text{ Gc : } 0.75'' \leq D_T < 4''$$

$$70 \text{ Gc : } 0.38'' \leq D_T < 2''$$

The minimum figures are determined by the above considerations whereas the maximum values follow from "depth-of-focus" considerations.⁽⁸⁾

FOCUSED ANTENNAS

In the present instance, a focused microwave beam is produced by inserting in the path of radiation a plastic lens which has a spherical phase front. A small conical horn is used to illuminate the lens (see Figure 3). The lens is constructed of low-loss polystyrene and consists of two identical plano-convex sections. The function of the curved surface opposite the feed horn is to convert the incident spherical wavefront into a plane wavefront. The second section of the lens is used to convert the plane wavefront into a spherical wavefront which converges towards the focal region. For simplicity in construction the feed distance and focal length are made to be equal, since this results in a symmetrical lens.

The focal ratio of the lens is unity in order to produce the smallest focused-beam size. At the same time the illumination across the lens is tapered, so that maximum collimation of the energy in the focal region may be achieved. The optimum taper has been obtained by using a small conical feed horn with the correct aperture-to-length ratio. It should be noted that this does not result in an optimum-gain horn, since the antenna system does not have maximum gain for the aperture size chosen. However this disadvantage is more than offset by the optimum collimation available.

Because the dimensions of the focal region are comparable to those of available pick-up antennas, the measurement of the properties of the

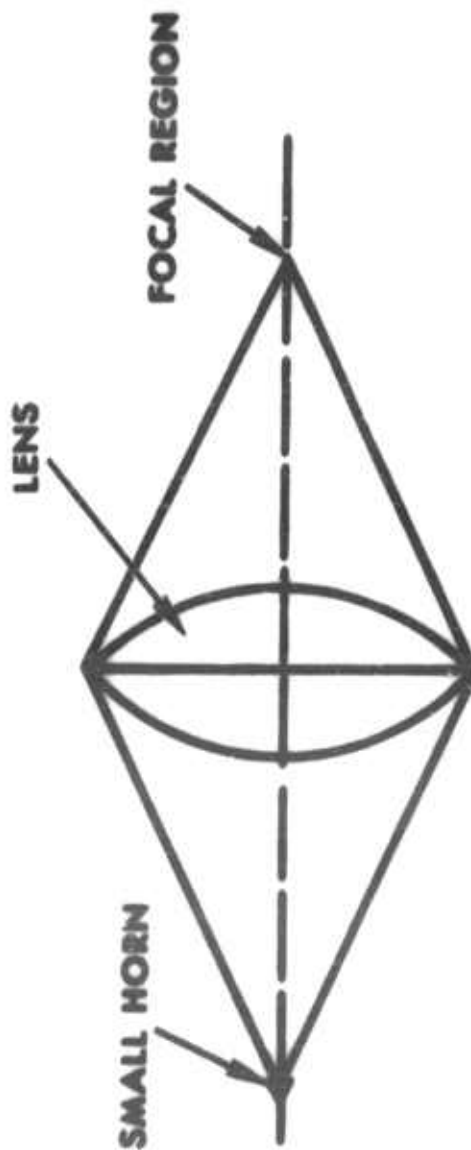

Figure 3 Focusing Lens

focal field is an extremely difficult task, and will not be dealt with in detail here. In brief, the field distribution in the focal region was obtained by measuring the backscatter from metallic spheres, very much smaller than the wavelength (about $1/5 \lambda$), which were made to traverse the focal region. An example of the measured field distribution in the focal plane is shown in Figures 4 (amplitude) and 5 (phase). The resolution of the lens was determined by passing two identical small spheres through the focal plane for various spacings between the spheres. The results are shown in Figure 6. Where the spheres are separated by more than a beamwidth, the field distribution in the focal plane is traced out by each sphere. As the spheres are placed closer together the two patterns ultimately overlap. An arbitrary criterion for resolution is taken to be the condition that two identical objects in the focal plane produce field patterns which overlap at the 3 db points. It can be seen, for the 70 Gc results shown, that the resolution is about $1/4''$, which is in good agreement with predictions based on the theoretical antenna pattern.

The manner in which the lens system shown in Figure 3 is utilized to construct a plasma probe is depicted in Figure 1. Identical lenses and feed horns are used for both transmission and reception. Each lens is mounted in the side of the two-foot-diameter section of the Flight Physics Range and forms an airtight seal with the range. The physical advantage of using a horn-lens combination rather than, say, an elliptical reflector is evident from this diagram.

The power transmission through the system is specified in terms of the insertion loss. When the feed horn is located on axis, the insertion loss has been found to be about 10 db, or 5 db per lens system, at

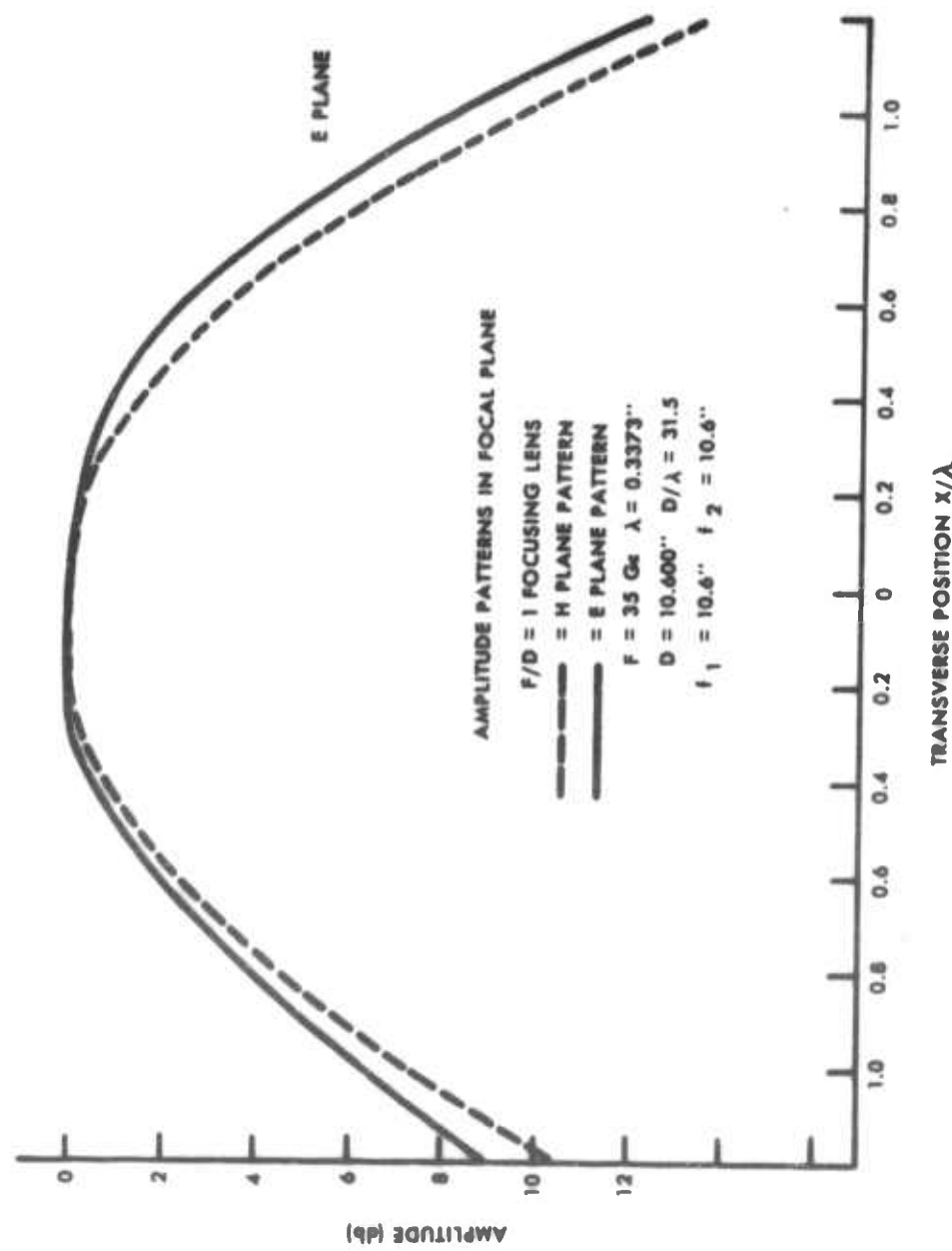

Figure 4 Amplitude Distribution in Focal Plane

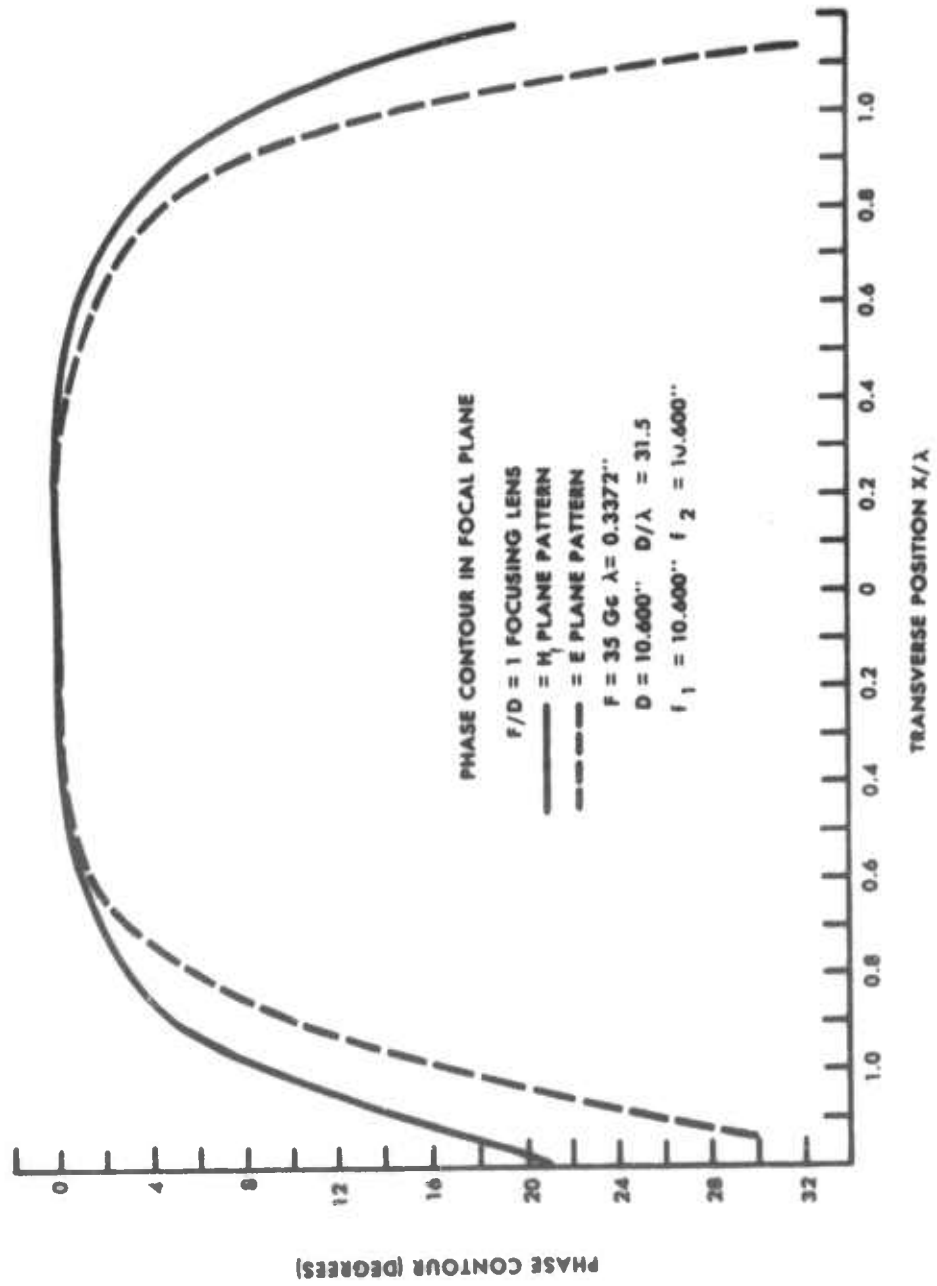
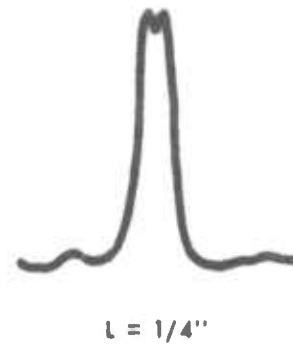
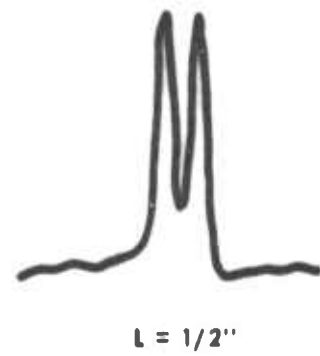
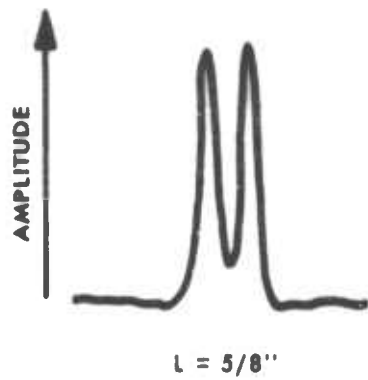

Figure 5 Phase Distribution in Focal Plane



NOTE: MEASURED PATTERNS TO BE REDUCED BY SPHERE DIAMETER (.093) TO GIVE ACTUAL BEAM PATTERN

Figure 6 70 Gc Probe Resolution Measurements

both 35 and 70 Gc. The loss can be reduced to about 3 db per lens by matching each curved surface. The residual loss (3 db per lens) is inherent in the lens-feed system and cannot be reduced without interfering with the collimating properties.

If single on-axis feed horns are used, the resulting focused beam will intercept some part of the flow field. In order to cover the major part of the flow field in the radial direction and also to allow for some dispersion in firing, it has been necessary to employ several adjacent beams, provided for by separate off-axis feed horns. The off-axis scanning properties of the system were investigated by a measurement of the transmission of a single beam, where the feed horns (transmitter and receiver) were moved in unison in a direction transverse to the axis. It was found that the horns could be moved about one inch off axis without any appreciable decrease in transmission (see Figure 7). Consequently, separate beams could be produced by locating additional pairs of feed horns, one on the transmitter side and the other on the receiver side, anywhere within a one-inch-radius circle, centered on axis. In general, the spacing between feed horns is made equal to the spatial resolution. Feed horns are stacked in a vertical plane normal to the flight path, and the polarization of adjacent channels is alternated in order to minimize cross-coupling between channels. The present disposition of the 35 and 70 Gc system beams in the focal plane is shown in Figure 8.

OVERALL SYSTEM DESCRIPTION

Seven-beam 35 and 70 Gc probe systems are now in use. The feed horns are arranged to produce the disposition of beams in the focal plane as

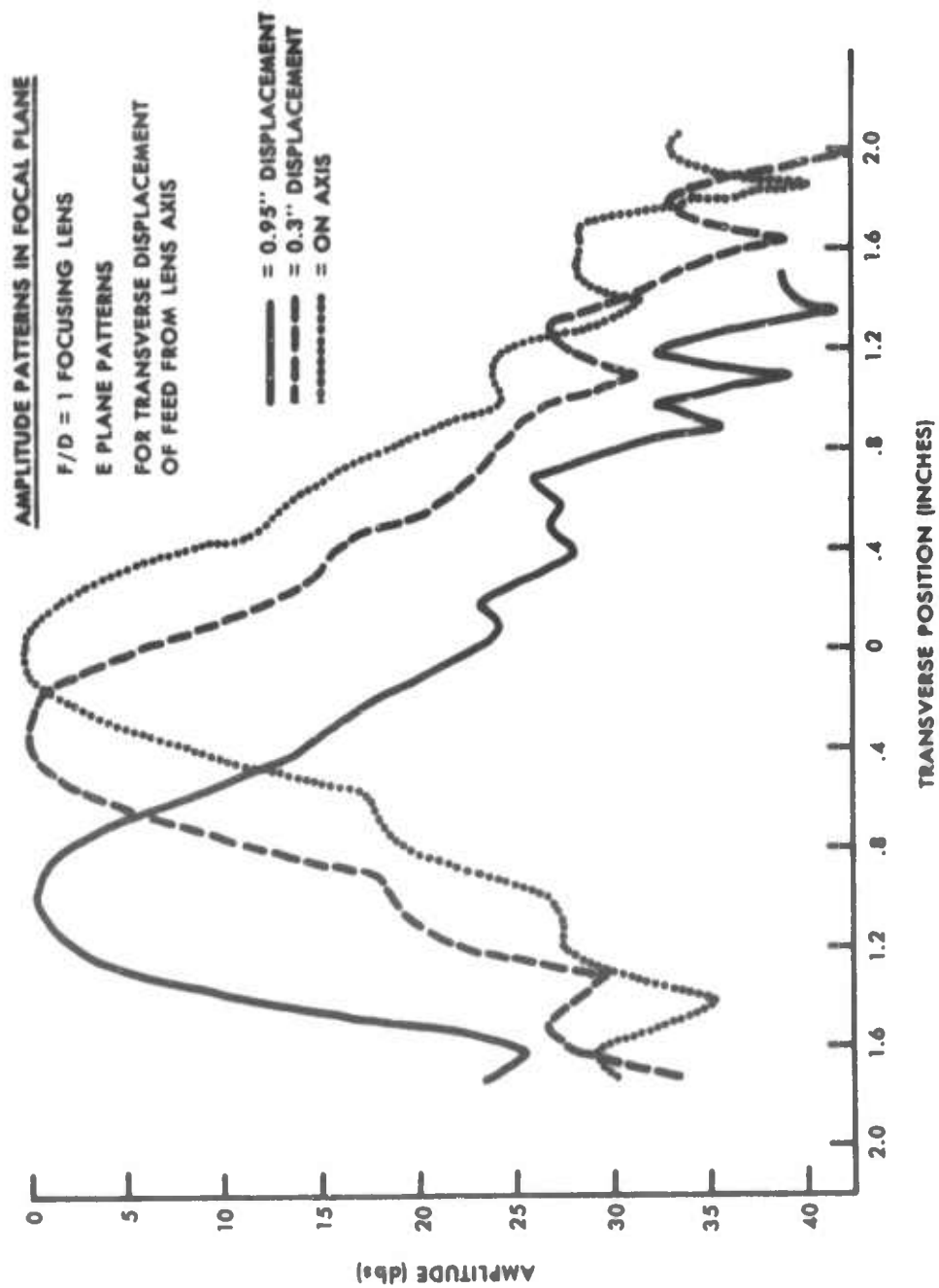

Figure 7 Off-Axis Scanning Properties of the Focusing Lens

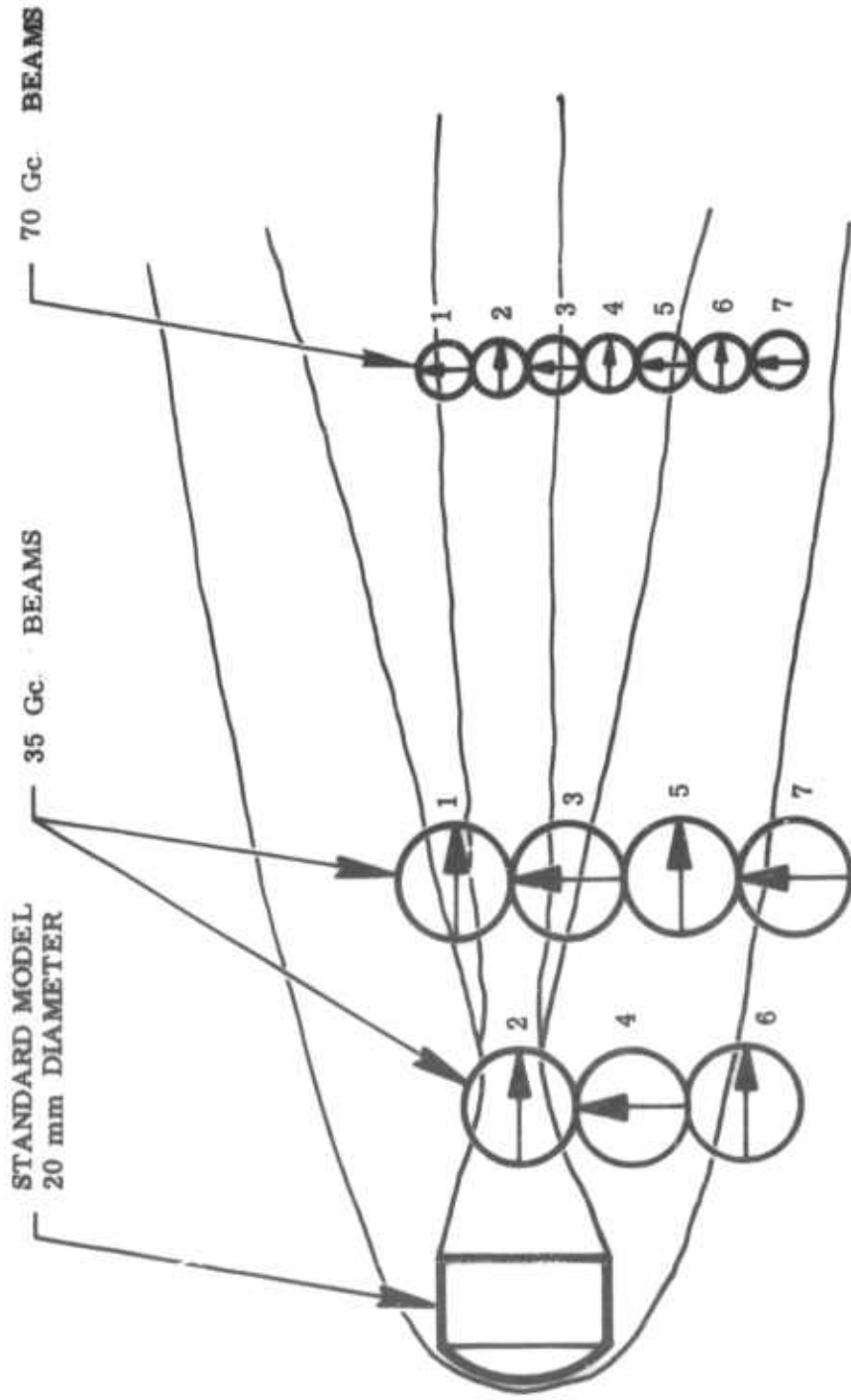

Figure 8 Ideal Disposition of Focused Microwave Beams Across a Hypersonic Wake

shown in Figure 8. Since both systems are identical in all essential details, the following description will be of one system only, namely the 35 Gc probe.

A schematic of the circuitry associated with one beam in the 35 Gc probe is shown in Figure 9. Part of the transmitter signal is beamed through the lens system to the receiver circuitry, while part of the signal is fed directly through a waveguide to the receiver as a reference signal. The level of the reference signal is very much greater than the signal transmitted through the lens system and this causes the receiver diodes to be biased so that they may be operated as autodyne mixers. The signal in each transmitter beam is split into two branches and is combined with the reference signal in the mixer diodes. By shifting the phase of the reference signal in one of the branches by 90° , two quadrature components of the transmitted signal are obtained. The absolute phase, that is the angle between the signal and reference phasers, is set to the desired initial value by adjusting the phase shifter in the common reference line. With the correct initial conditions, the demodulated output can be expressed as $A(t)\sin\phi(t)$ and $A(t)\cos\phi(t)$, where $A(t)$ and $\phi(t)$ are the time-varying amplitude and phase respectively of the transmitted signal. The amplitude and phase can now be derived explicitly, the former as the square root of the sums of squares of the output and the latter as the arc tangent of their ratio. The desired initial conditions are set accurately before each firing with a special calibration method, described in the following section.

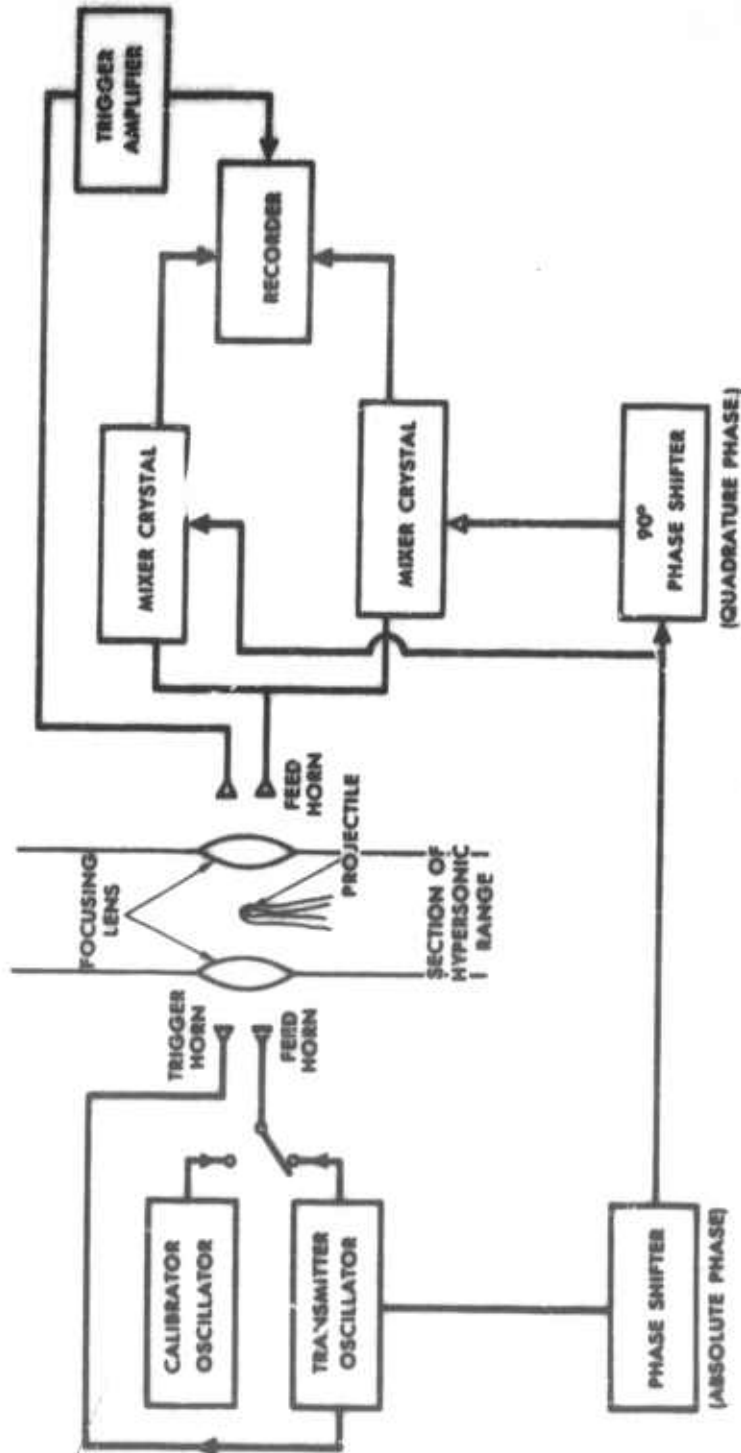

Figure 9 35 Gc Probe Circuit

CALIBRATION

The essential requirement of calibration is to set the initial phase and amplitude conditions to give a suitable display which can be readily analyzed. The relative phase of the signals in the branches of a given channel must be set in quadrature to obtain the sine and cosine components of the output signal; also, the sine and cosine components in all the channels must have the same phase relationship with respect to the reference signal. The absolute phase ϕ_0 , that is, the arbitrary phase between the transmitted signal vector and the reference vector, must be set to some convenient value which we choose to be $(2n-1)\pi$ radians. The amplitude A_0 must also be set for all channels to give a known deflection on the oscilloscope.

The quadrature phase and amplitudes are set by the use of a calibrator signal source which is phase coherent but offset in frequency from the transmitter source by a small amount, say 1 Mc. When this calibrator signal, which is set to the same power level, is substituted for the transmitter signal going to the feed horns while part of the transmitter signal source is still used for the phase reference signal, the output is a simulated pure phase shift which is changing linearly with time. This CW signal is readily displayed and permits adjustment of the peak-to-peak deflection ($2A_0$) and the quadrature phase.

The absolute phase ϕ_0 is set by periodically cutting off the transmitter signal to the feed horns. The outputs on the sine and cosine displays are rectangular pulses whose amplitudes depend on the value of ϕ_0 . For $\phi_0 = n\pi$ radians, the magnitude of deflection is zero in the sine component and is A_0 in the cosine component. ϕ_0 is set at $(2n-1)\pi$

radians by observing the polarity of the deflection in the cosine channel. A ferrite modulator having a high on-off ratio, placed in the common line to the transmitter feed horns, is used to amplitude-modulate the transmitter signal.

Description of Calibrator

The generation of the calibrator signal is based on the use of another klystron which is phase-coherent to the transmitter klystron but offset from it by a small difference frequency.⁽⁸⁾

The operation of the circuitry is best described by referring to Figure 10. A reference signal from the transmitter klystron is used to generate a single sideband signal. As 30 Mc IF amplification is used in the phase-locking loop, the sideband modulator is set at $30 \text{ Mc} + \Delta f$, where Δf is the desired difference frequency between the transmitter and calibrator klystrons. For the 35 Gc system, the upper sideband $\{35 \text{ Gc} + (30 \text{ Mc} + \Delta f)\}$ is mixed with the output of the calibrator klystron in a balanced mixer. When the frequency of the calibrator klystron is at $35 \text{ Gc} + \Delta f$, the mixer output is 30 Mc. The amplified 30 Mc signal is compared with a 30 Mc reference signal in a phase detector. The output voltage from the phase detector is applied to the repeller of the calibrator klystron to keep it phase-locked at $35 \text{ Gc} + \Delta f$. As the modulator which drives the single sideband generator can be varied in frequency, Δf can be varied from 0 to 10 Mc. This feature makes it possible to make a rapid and accurate overall check of the frequency response of the receiver and recording equipment.

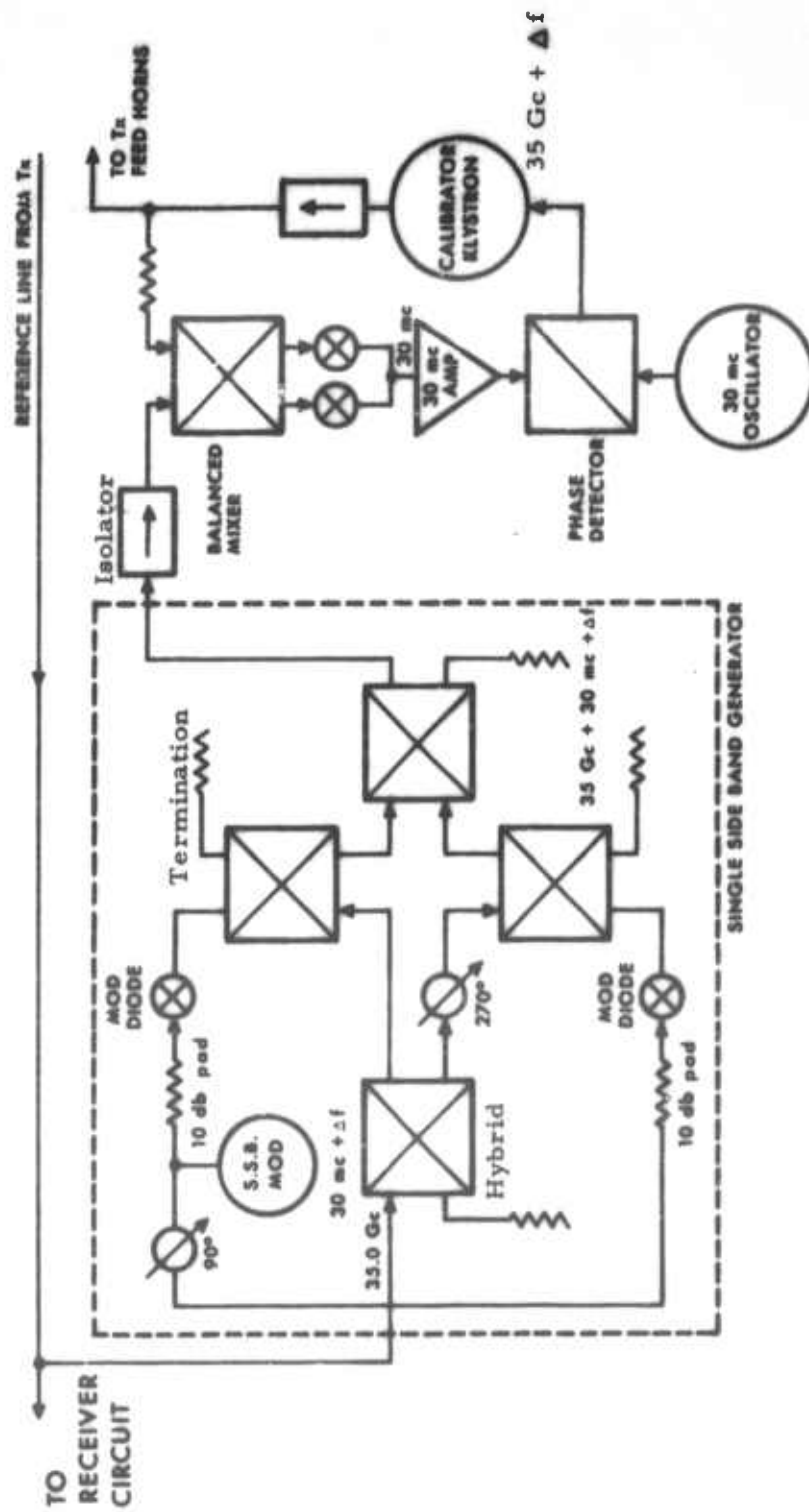

Figure 10 Phase-Locked Calibration Circuit

RANGE INSTALLATION OF FOCUSED PROBE

Each probe is constructed as a module. The lenses are mounted in the sides of a two-foot-diameter, removable section of the Flight Physics Range. All associated waveguide is rigidly mounted on the module. This form of construction has permitted the entire probe unit to be assembled and tested in the laboratory. The completed unit is then installed on the range.

The 70 Gc module is shown in Figure 11, and the 35 and 70 Gc probes are shown installed on the Flight Physics Range in Figure 12.

RESULTS OBTAINED WITH FOCUSED PROBES

Many firings have been observed with the equipment described above. The analysis of the reduced data from the firings will be published elsewhere, however it may be instructive to include here some data which is indicative of what may be obtained with the use of these probes.

Attenuation of a 35 Gc beam through a particular wake is shown in Figure 13. The first peak of attenuation is due to the passage of the projectile through the beam. The second peak is due to intense ionization in the flow-recompression zone immediately behind the projectile. A similar result is shown in Figure 14 for a 70 Gc beam. Here the improved resolution which results from the use of the higher frequency is evident. These two figures are examples of what are believed to be the first microwave measurements which have confirmed the existence of intense ionization in the recompression zone behind blunt hypersonic projectiles.

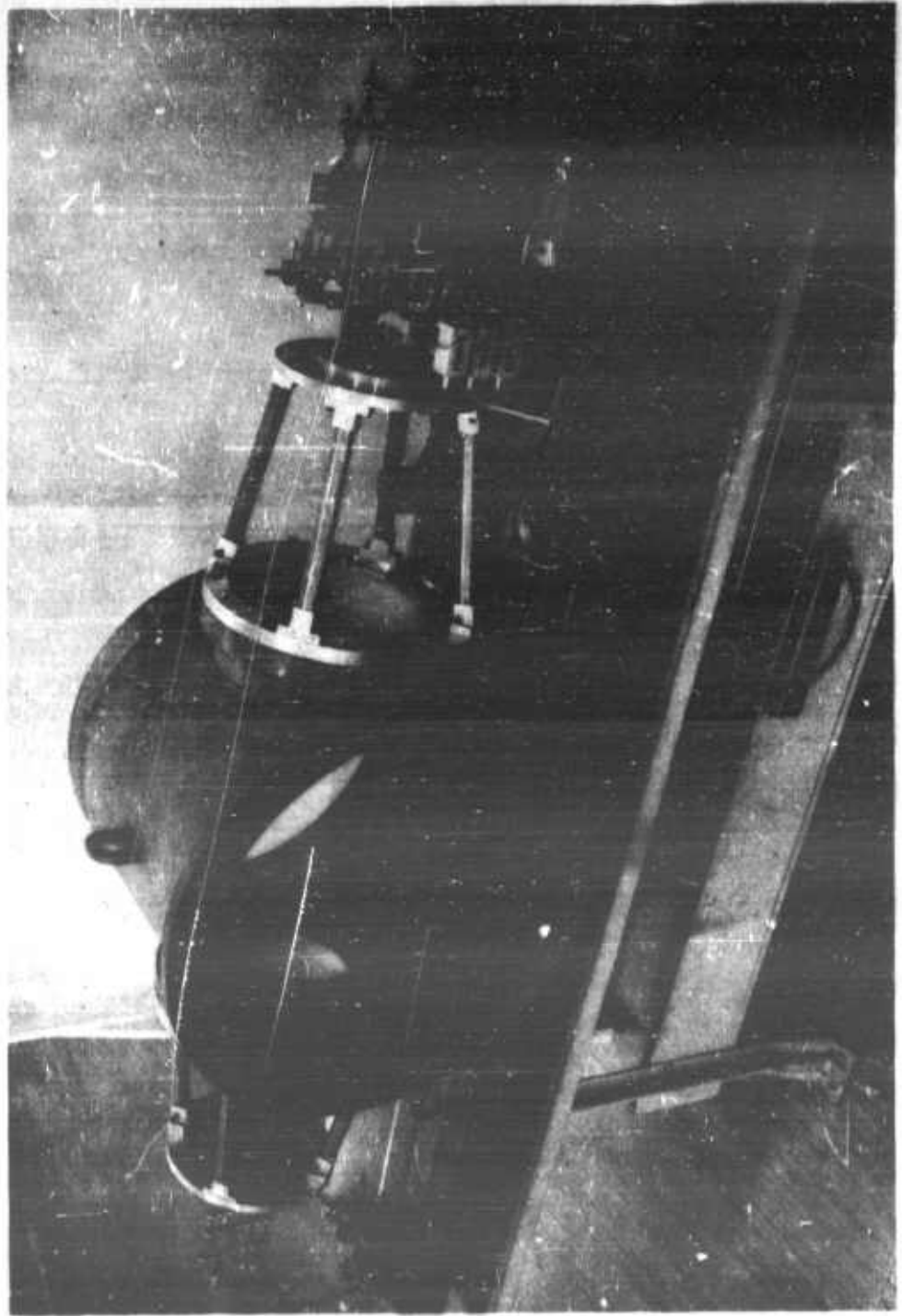

Figure 11 70 Gc Focused Probe Module

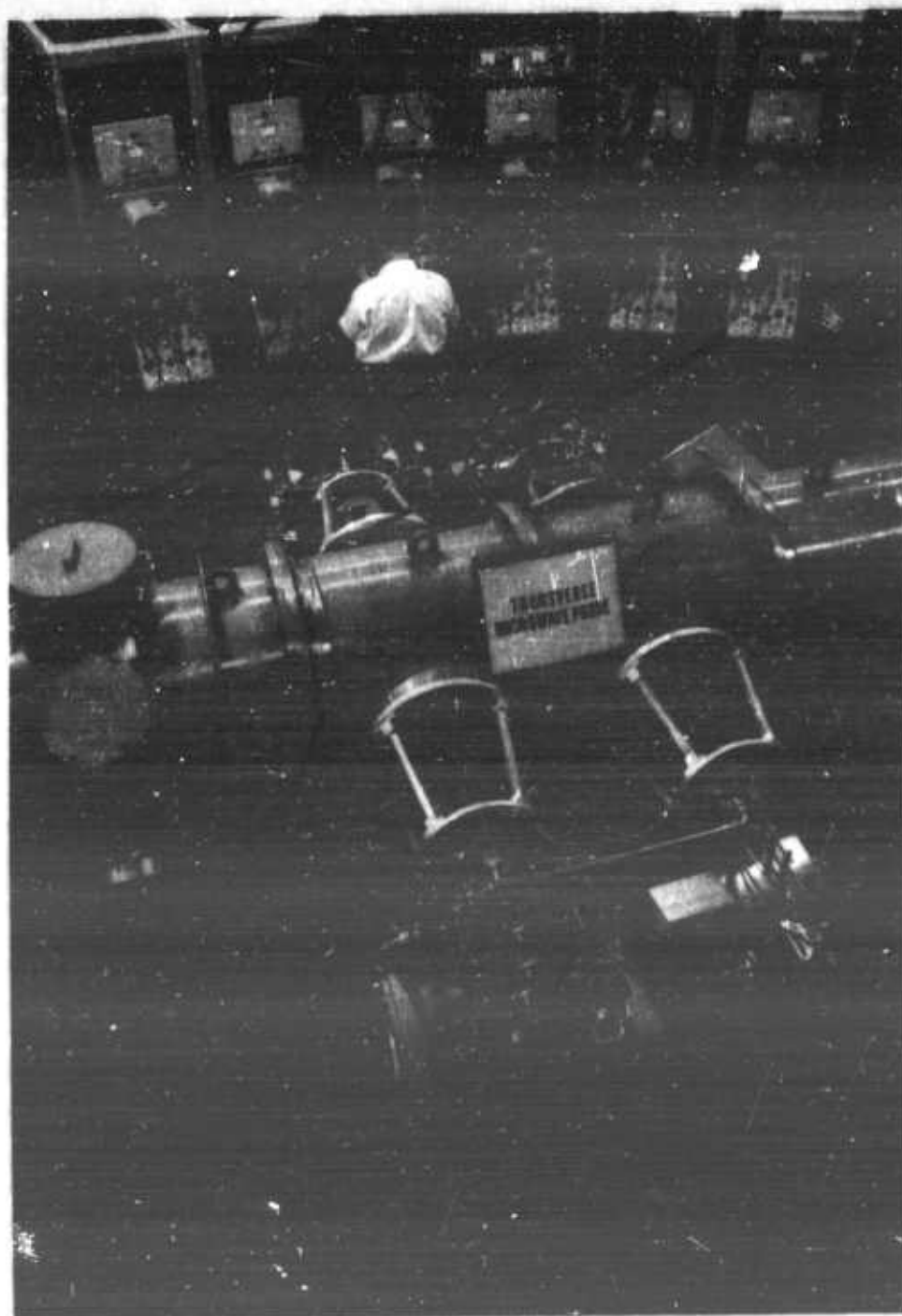

Figure 12 35 and 70 Gc Probe Installation on Range

$v=22,700$ fps

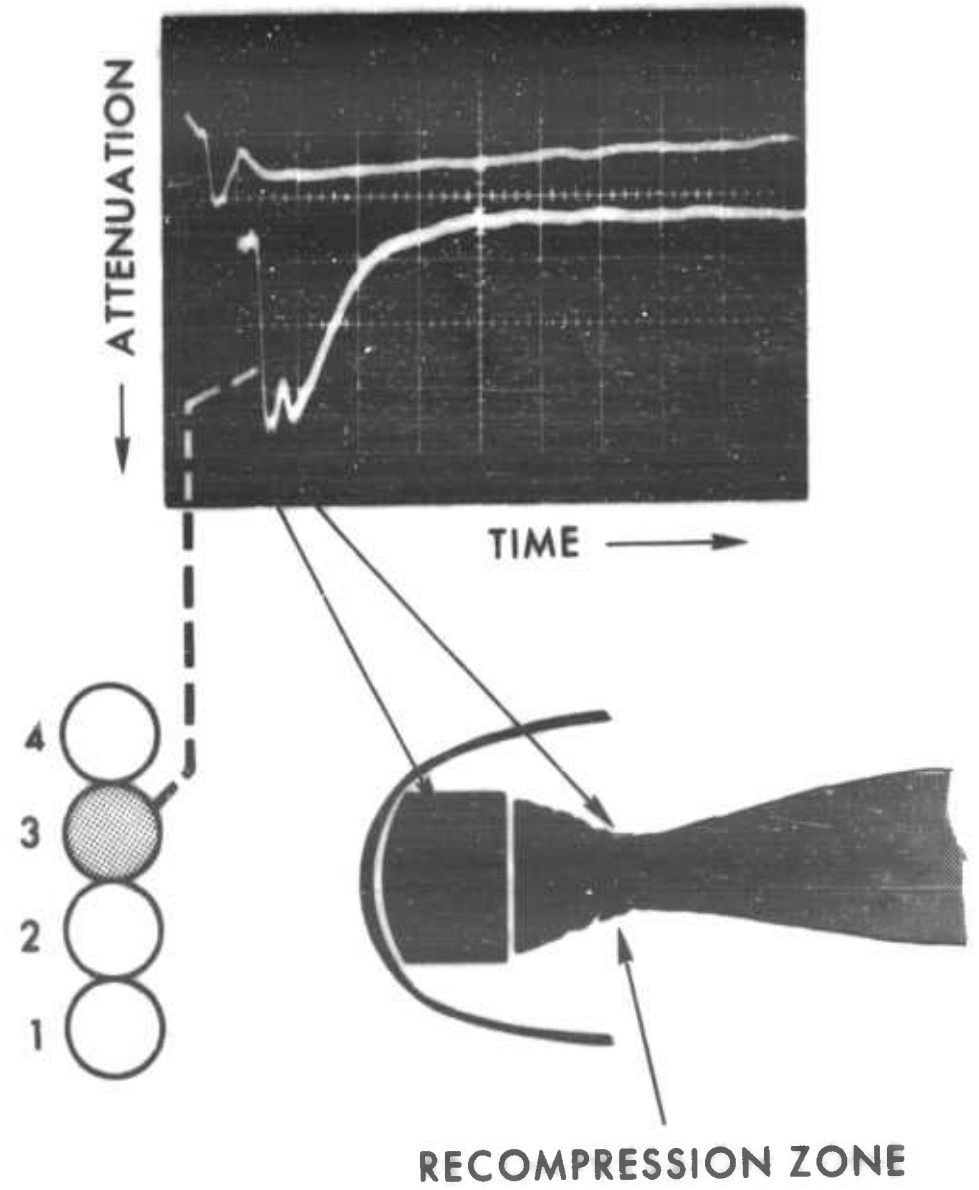
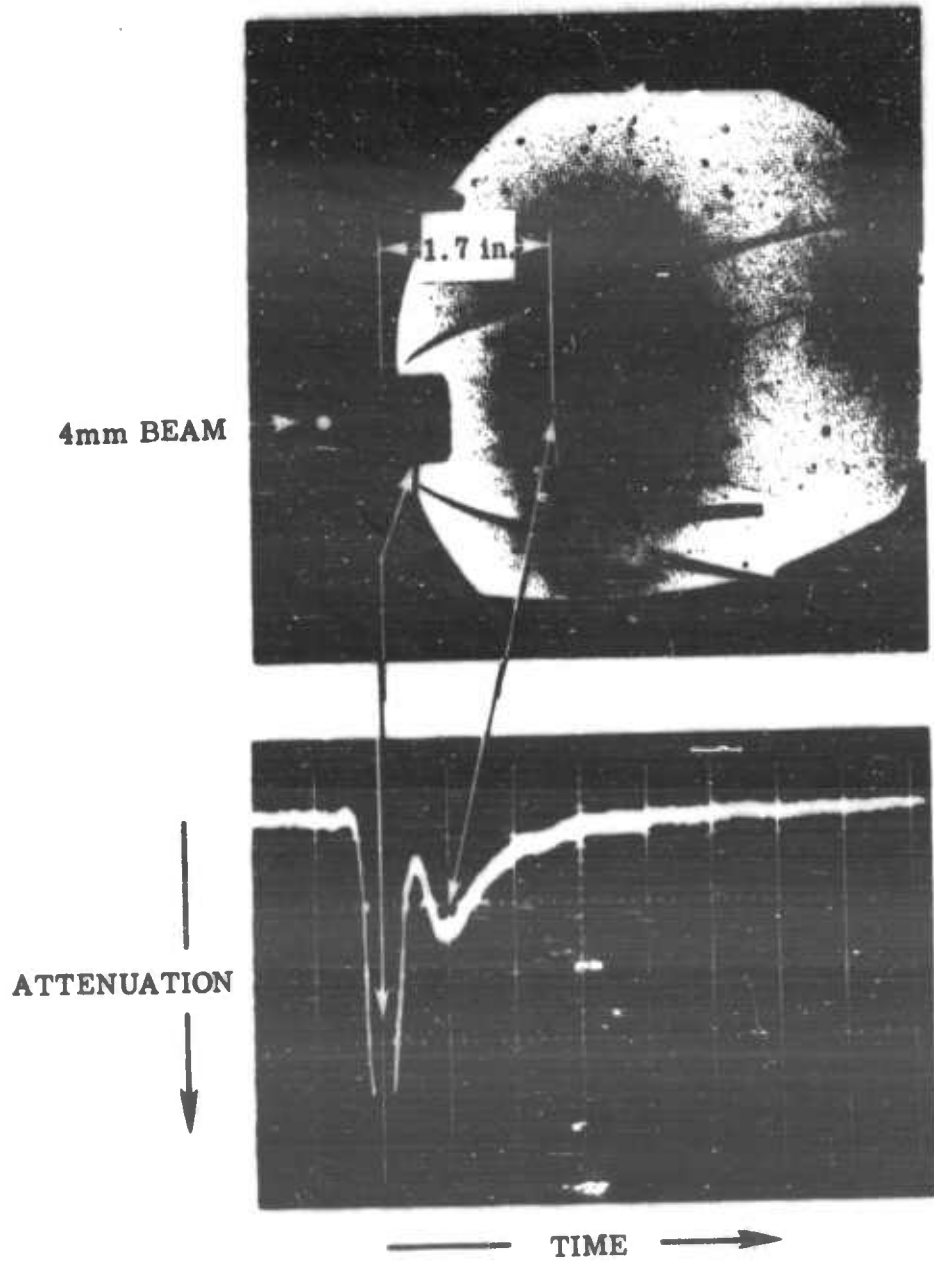

Figure 13 35 Gc Beam Attenuation



Transverse Microwave Probe:
Results with 70-Gc System;
V=16, 100 ft/sec, P = 106mmHg(Air)

Figure 14 70 Gc Beam Attenuation

An indication of the radial variation of ionization behind hypersonic projectiles is given in Figures 15 and 16, in which are shown attenuation and phase shift of each beam in the seven-beam 70 Gc probe. It will be recalled that adjacent beams are only $1/4$ " apart in the radial direction.

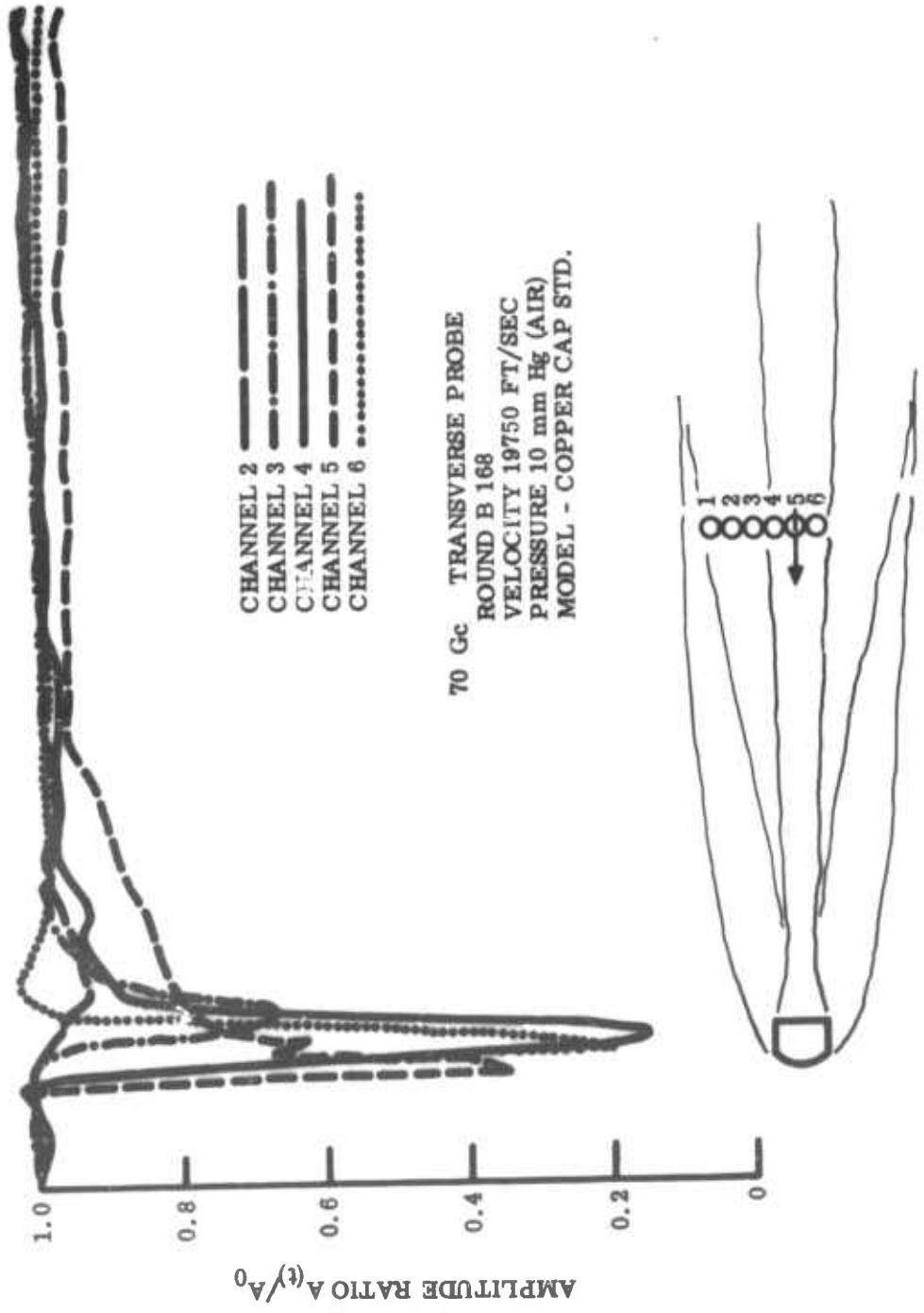

Figure 15 Seven-beam 70 Gc Probe. Attenuation

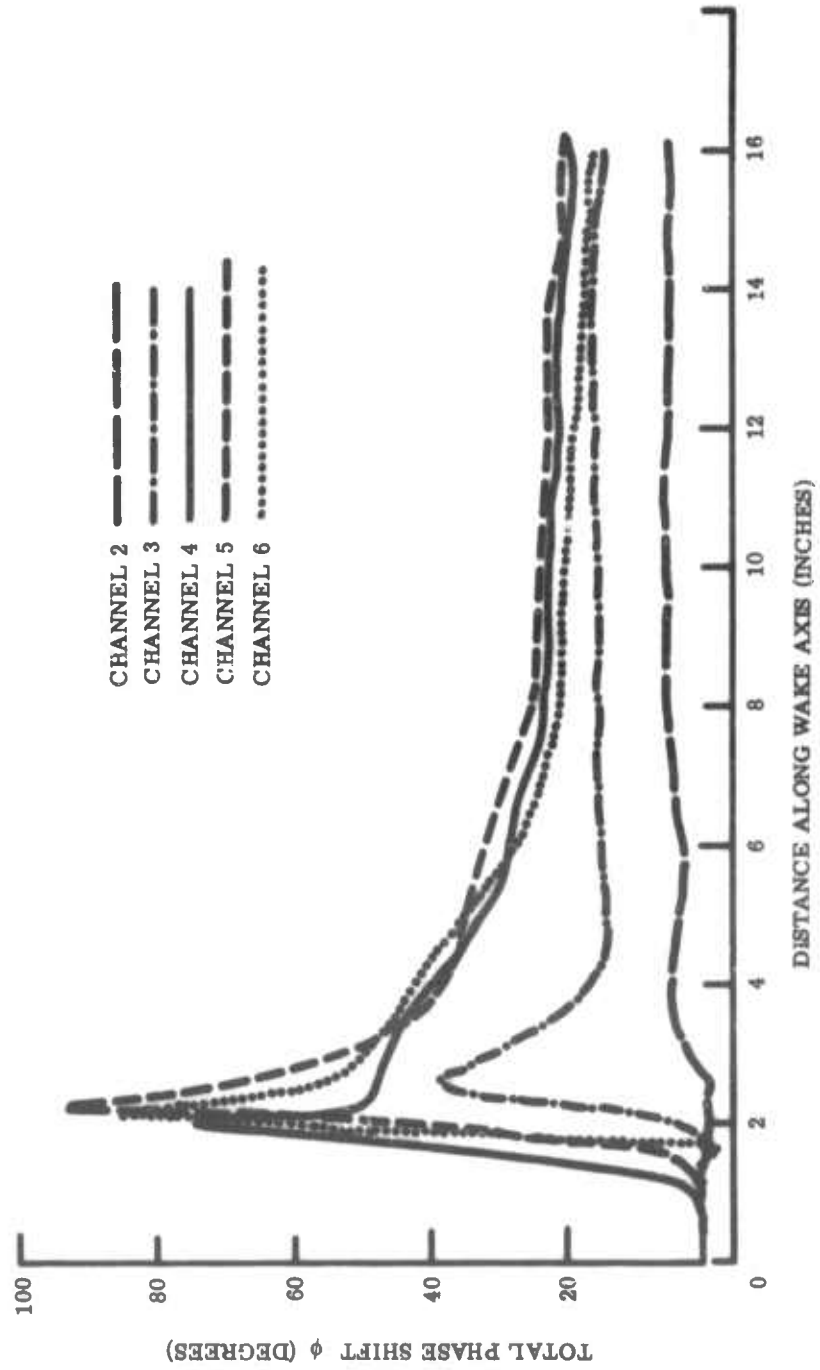

Figure 16 Seven-beam 70 Gc Probe. Phase Shift

SECTION IV

FOCUSED RESONANT PROBES

The measurement of low electron densities in hypersonic wakes in free flight ranges has been a difficult problem. The use of appropriate low frequencies, which has been widely exploited, has provided adequate sensitivity but has resulted in very poor spatial resolution. For many experimental observations, the best resolution available is inadequate. In any case the resolution applies to axial variations in density only. To date no demonstrated method of measuring radial density gradients with low-frequency techniques has been demonstrated. Low frequencies imply wavelengths much greater than the effective diameter of the wake.

The use of millimeter wavelengths has provided adequate spatial resolution both radially and axially, but sensitivity is limited. For instance, with maximum gain the 35 Gc probe can be used without difficulty to measure electron densities as low as 10^{10} e/cc. It was indicated in the previous section that this is adequate for many studies. However, additional sensitivity is essential for some wake measurements, especially at extreme altitudes.

Investigations have been made to examine techniques which preserve the resolution of the 35 and 70 Gc probes but which are orders of magnitude more sensitive. Results of some preliminary experiments on a focused resonator which offer a significant improvement in sensitivity are now discussed.

In the simple focused probe the minimum electron density that can be measured is determined by the smallest measurable phase shift. If the wave could be made to pass through the trail many times, then the resultant phase shift would be many times that of the direct phase shift. An effective way of achieving this is to locate the trail at the focal point of a focused, free-space resonator. The proposed resonator is shown in Figure 17. The configuration is essentially that of the transverse probe except that two thin, perforated, spherical, metallic plates which have very high reflectivity have been added. It was argued that, by analogy with the classical parallel-plate Fabry-Perot resonator, this device would resonate for some critical frequency and plate spacing. The Q was expected to be very high and the resolution in the focal plane was expected to be better than for the nonresonant probe. Such a system, in which the mechanical tolerances are extremely severe, has been constructed and tested with satisfactory results.

While construction was proceeding, a simple alternate form of the resonator was operated successfully. This is shown in schematic form in Figure 18. Two flat, perforated, metallic plates are located between the two halves of each focusing lens in an existing focused probe. It was realized that the inside sections of each dielectric lens would be inside the cavity and this would cause a serious deterioration of Q . However, since the cavity was able to be assembled from available equipment, it was studied. The frequency of the incident wave is varied linearly and both reflection and transmission were measured. Resonance was easily detected, and a typical example is shown in Figure 19. For these conditions it was found that the Q was about 5,000. Of more importance, it

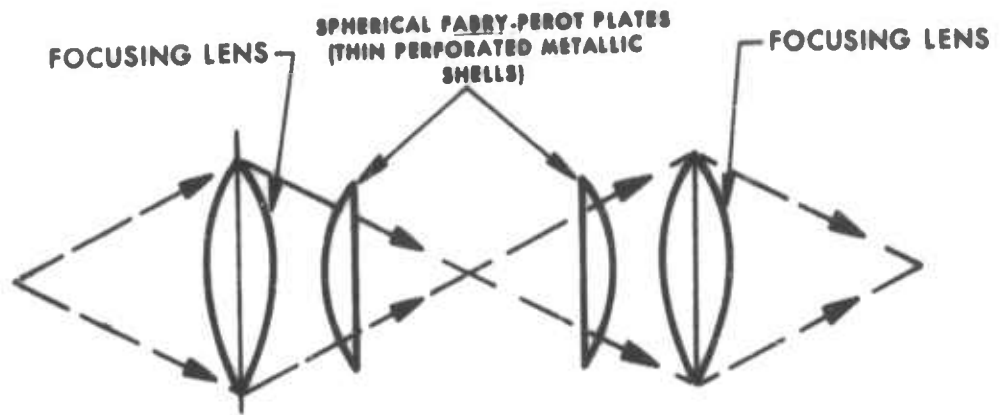

Figure 17 Proposed Focused Resonator

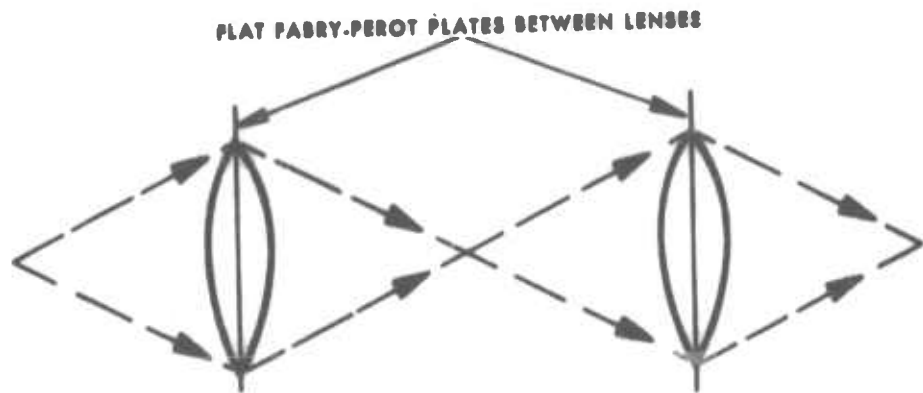

Figure 18 Alternate Form of Focused Resonator

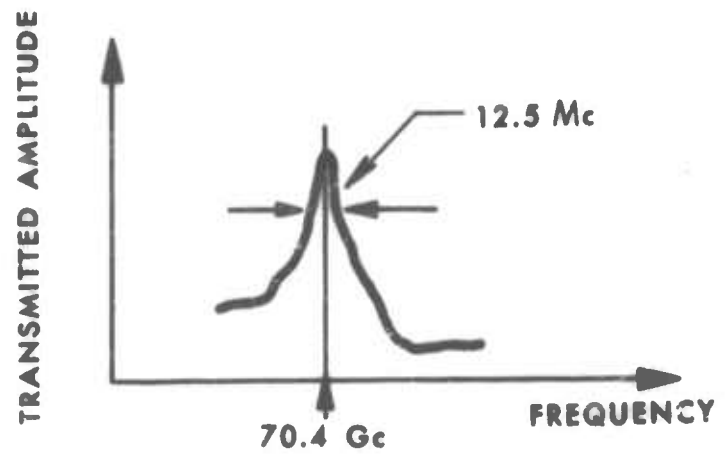
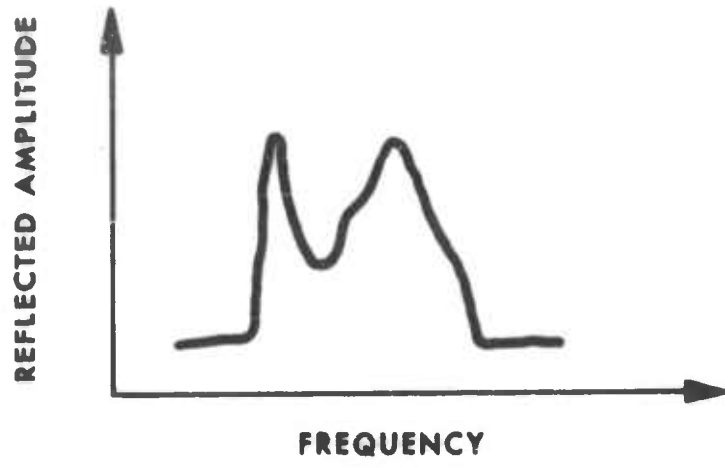

Figure 19 Focused Resonator. Typical Results, Amplitude vs Frequency

was found by experimenting with polyfoam that dielectric constants equivalent to electron densities of about 10^9 e/cc could be measured.

In the above method of measuring dielectric constant, the shift in resonance frequency due to the presence of the dielectric is detected. The shift corresponding to 10^9 e/cc is about 0.5 Mc. More sensitive techniques of measuring dielectric constants with this cavity are available and are being investigated. It is anticipated that in conjunction with one of these methods the first form of resonator shown will provide a sensitivity approaching 10^8 e/cc.

Preliminary results on the spherical resonator show that Q's of about 100,000 can be achieved at 70 Gc, with the reflectors located on a ten-inch-diameter circle. A typical result is shown in Figure 20. The transmission curve is seen to be much "cleaner" than that shown in Figure 19, which may indicate that spurious resonant modes are virtually absent.

Details of the reflector plates mounted in a focused-probe module are shown in Figure 21.

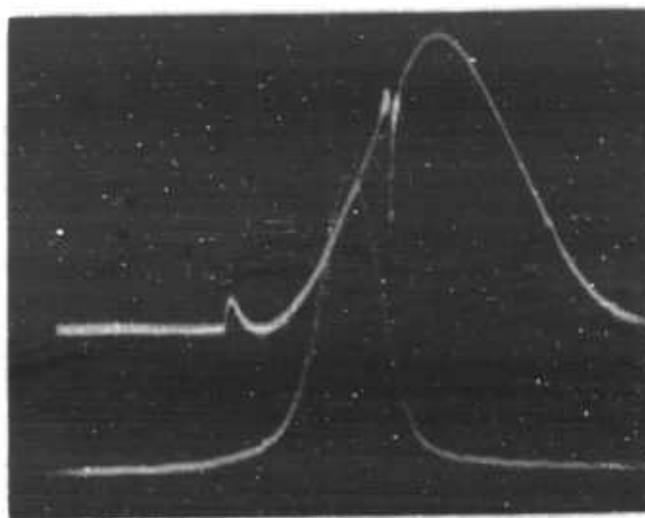

- a. Top Trace.
Reflection: Fabry-Perot mode superimposed on mode of cavity with a Q of 1300.
Time base. $500 \mu\text{sec/cm}$. or $22.4 \mu\text{sec/Mc}$
- b. Transmission through Fabry-Perot as a Function of Frequency.
Time base. $10 \mu\text{sec/cm}$ or $22.4 \mu\text{sec/Mc}$.

Note: Vertical scale not linear. Q was measured at half-power points using an attenuator and was found to be about 100,000.

Figure 20 Focused Resonator. Typical Results

TR63-217C

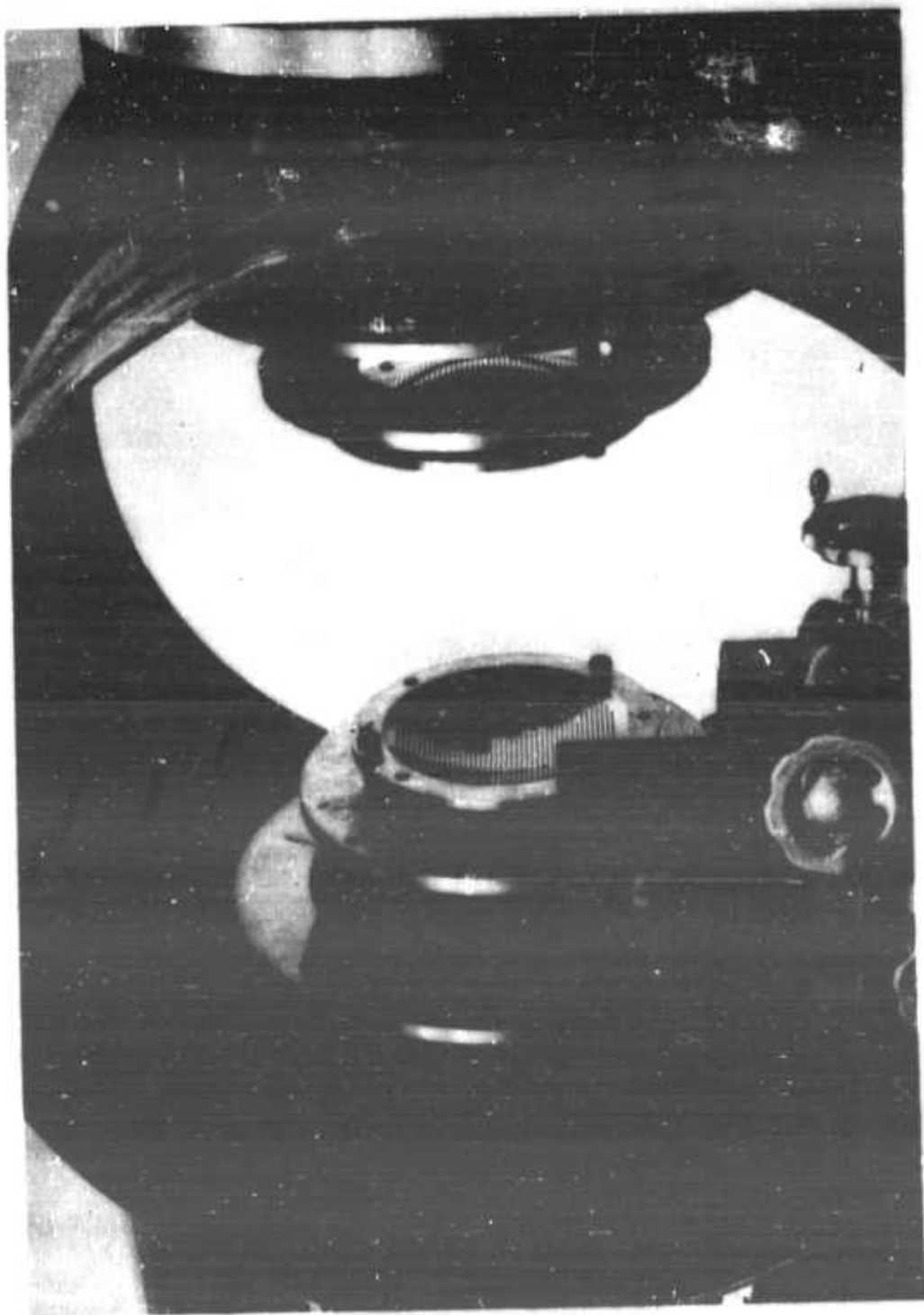

Figure 21 Photograph of Focused Resonator

REFERENCES

1. R. I. Primich and R. A. Hayami, Ionization in Hypersonic Wakes, GM Defense Research Laboratories TR62-209D, Contract DA-04-495-ORD-3567, Santa Barbara, California, January 1963
2. Lincoln Laboratory Staff, Massachusetts Institute of Technology, (see Semiannual Technical Summary Reports on Reentry Physics Program)
3. K. Baldwin, R. Buck, T. Fessenden, and L. McGuire, "Transient Plasma Diagnostics for Wake Studies," Published in Proc. Second Symposium Hypervelocity Techniques, Denver, March 1962
4. M. Dagai, "Techniques et Equipments de Mesure de Densite de Plasma de L'Ordre de 10^{14} e/cm³," (paper presented at the Conference on Ionization Phenomena in Gases, Munich, 1961)
5. H. Lashinsky, Princeton University, Personal Communication
6. R. I. Primich, "Microwave Techniques for Hypersonic Ballistic Ranges," Electromagnetic Effects of Reentry, Pergamon Press, 1961, pp. 186-195
7. R. A. Hayami, "A Microwave Interferometer Using High Resolution Focused Beams for Plasma Studies," (Paper presented at the IRE Conference, Toronto, Canada, October 1961)
8. GM Defense Research Laboratories, Instrumentation, Calibration, and Data Reduction Methods, compiled by W. A. Koch, TR62-213, Contract DA-04-495-ORD-3567, Santa Barbara, California, January 1963
9. R. I. Primich and F. H. Northover, "Use of Focused Antenna for Ionized Trail Measurements," Trans. I. E. E. E., PGAP, AP-11 March 1963, p. 112

10. R. F. Whitmer, "Microwave Studies of the Electron Loss Processes in Gaseous Discharges," Phys. Rev., Vol. 104, 1956, p. 572
11. M. P. Bachynski, RCA Victor Co., Montreal, Personal Communications
12. P. A. Matthews and A. L. Cullen, "A Study of the Field Distribution at an Axial Focus of a Square Microwave Lens," Proc. I. E. E. (London), Pt. C, Vol. 103, Sept 1956, p. 449
13. F. H. Northover, The Incidence of Focused Microwaves Upon Ionized Distributions, Part I - Plane Distributions, GM Defense Research Laboratories TR62-209N, Contract DA-04-495-ORD-3567, Santa Barbara, California, Dec 1962
14. S. Zivanovic, A Numerical Method for the Determination of Transmission and Reflection Coefficients of a Non-Uniform Plasma Slab, GM Defense Research Laboratories TR62-209J, Contract DA-04-495-ORD-3567, Santa Barbara, California, Dec 1962
15. S. Zivanovic, Transmission and Reflection Coefficients on a One-Dimensional Plasma Slab with Exponential and Parabolic Electron Density Distribution, GM Defense Research Laboratories TR62-209K, Contract DA-04-495-ORD-3567, Santa Barbara, California, Dec 1962
16. G. R. Nicoll and J. Basu, "Reflection and Transmission of an Electromagnetic Wave by a Gaseous Plasma," Proc. I. E. E. (London), Pt. C, 1962, p. 335
17. F. H. Northover, The Incidence of Focused Microwaves Upon Ionized Distributions, Part II - Cylindrical Distributions, GM Defense Research Laboratories TR62-209N, Contract DA-04-495-ORD-3567, Santa Barbara, California, Jan 1963
18. H. M. Musal, Jr., Plasma Frequency and Electron Collision Frequency Charts for Hypersonic Vehicle Equilibrium Flow Fields in Air, GM Defense Research Laboratories TR62-209C, Contract DA-04-495-ORD-3567, Santa Barbara, California, Dec 1962

DISTRIBUTION LIST
for Analysis Reports on the
HYPERVELOCITY RANGE RESEARCH PROGRAM

<u>Recipient</u>	<u>Copy No.</u>	<u>Recipient</u>	<u>Copy No.</u>
Commanding General U. S. Army Missile Command Redstone Arsenal, Alabama ATTN: ORDXM-RRX	1-12	ARO, Incorporated von Karman Facility, Arnold AF Station Tullahoma, Tennessee ATTN: J. Lukasiewicz	34
Los Angeles Procurement District, U. S. Army 55 South Grand Avenue Pasadena, California ATTN: F. K. Whitburn, Contracting Officer	13	Aerojet-General Corporation Azusa, California ATTN: C. Dunning	35
Director Advanced Research Projects Agency Washington 25, D. C. ATTN: F. Koether ATTN: E. Haynes ATTN: C. McLain ATTN: Lt Col Cooper	14-16 17 18 19	Armour Research Foundation 10 W. 35th Street Chicago 16, Illinois ATTN: Fluid Dynamics Research Division	36
Armed Services Technical Information Agency Arlington Hall Station Arlington 12, Virginia ATTN: J. H. Heald	20-29	Battelle Memorial Institute 505 King Avenue Columbus 1, Ohio ATTN: Battelle-DEFENDER	37
Avco-Everett Research Laboratory 2385 Revere Beach Parkway Everett, Massachusetts ATTN: R. Taylor	30	Barnes Engineering Company 30 Commerce Road Stamford, Connecticut ATTN: H. Yates	38
Aerospace Corporation 2400 E. El Segundo Boulevard El Segundo, California ATTN: D. Bitondo	31	Bell Telephone Laboratories, Inc. Whippany, New Jersey ATTN: C. W. Hoover, Room 2B-105	39
Aerospace Corporation P. O. Box 95085 Los Angeles 45, California ATTN: J. Logan	32	Bendix Corporation Systems Division 3300 Plymouth Road Ann Arbor, Michigan ATTN: Systems Analysis and Math. Dept.	40
Avco Corporation Research and Advanced Development Division Wilmington, Massachusetts ATTN: H. Flickinger	33	Boeing Airplane Company P. O. Box 3707 Seattle, Washington ATTN: Org. 2-5732/J. Klaimon	41
		Brown Engineering Company P. O. Drawer 917 Huntsville, Alabama ATTN: H. Crews	42

DISTRIBUTION LIST (continued)

<u>Recipient</u>	<u>Copy No.</u>	<u>Recipient</u>	<u>Copy No.</u>
Commanding General U. S. Army Materiel Command Washington 25, D. C.	43	California Institute of Technology Pasadena, California ATTN: Prof. L. Lees	57
Commander U. S. Army Missile Command Redstone Arsenal, Alabama ATTN: AMSMI-RB	44	Cornell Aeronautical Laboratory 4455 Genesee Street Buffalo 21, New York ATTN: J. Lotsof	58
ATTN: AMSMI-RRX	45	ATTN: W. Wurste	59
ATTN: AMSMI-RNR	46		
Commanding General U. S. Army Air Defense Command Colorado Springs, Colorado ATTN: Advanced Projects Division, G-3	47	Director Ames Research Center Moffett Field, California ATTN: H. Allen	60
Commanding General U. S. Army Ballistics Research Laboratories Aberdeen Proving Ground, Maryland ATTN: C. H. Murphy	48	Defense Research Corporation 4050 State Street Santa Barbara, California ATTN: W. Short	61
Commanding General U. S. Army Research and Development Washington 25, D. C. ATTN: Intl. Division	49	Director USAF Cambridge Research Laboratories Laurence Hanscom Field Bedford, Massachusetts ATTN: CRREL, Stop 29	62
ATTN: Physical Sciences Division	50		
Commanding General U. S. Army Elec. and Communications Command Research and Development Fort Monmouth, New Jersey	51	Director USAF Office of Scientific Research Washington 25, D. C. ATTN: Mechanics Division/Major Terrell	63
Chief U. S. Navy Bureau of Weapons Washington 25, D. C. ATTN: RMWC-322	52	Director Electromagnetic Warfare Laboratory Wright-Patterson Air Force Base Dayton, Ohio ATTN: ASRN/W. Bahret	64
Director U. S. Naval Research Laboratory Washington 25, D. C. ATTN: Code 2027	53	Director Institute for Defense Analyses 1666 Connecticut Avenue, N. W. Washington 9, D. C. ATTN: J. Menkes	65
		ATTN: J. Martin	66
		ATTN: D. Katcher, JASON Library	67
Central Intelligence Agency 2930 E Street, N. W. Washington, D. C. ATTN: OCR Standard District	54-56	Director Weapon Systems Evaluation Group Pentagon, Room 1E-800 Washington 25, D. C.	68

DISTRIBUTION LIST (continued)

<u>Recipient</u>	<u>Copy No.</u>	<u>Recipient</u>	<u>Copy No.</u>
Director Langley Research Center Langley Field, Virginia ATTN: W. Erickson	69	Headquarters, ARDC Andrews Air Force Base Washington, D. C. ATTN: Col Fazio/Intl. Programs	79
Director Marshall Space Flight Center Huntsville, Alabama ATTN: M-AERO-TS	70	Jet Propulsion Laboratory 4800 Oak Grove Drive Pasadena, California ATTN: H. Denslow	80
Electro-Optical Systems, Inc. 125 N. Vinedo Avenue Pasadena, California ATTN: R. Denison	71	Kaman Nuclear Division Colorado Springs, Colorado ATTN: A. Bridges	81
Ford Motor Company Aeronutronics Division Ford Road Newport Beach, California ATTN: H. Hall ATTN: R. Hoglund	72 73	Lockheed Corporation Missiles and Space Division Sunnyvale, California ATTN: Ray Munson	82
General Applied Sciences Laboratories Merrick and Stewart Avenues Westbury, Long Island, New York ATTN: M. Bloom	74	Martin Aircraft Company Orlando, Florida ATTN: J. Mays	83
General Dynamics Corporation Astronautics Division San Diego, California ATTN: W. Hooker 6-172	75	Massachusetts Institute of Technology Lincoln Laboratory P. O. Box 73 Lexington 73, Massachusetts ATTN: M. Herlin ATTN: R. Slattery	84 85
General Electric Company Reentry Vehicles Division 3198 Chestnut Street Philadelphia, Pennsylvania ATTN: L.I. Chaseen, Room 3446	76	Melpar, Inc. Applied Science Division 11 Galen Street Watertown 72, Massachusetts ATTN: Librarian	86
General Electric Company Valley Forge Space Technical Center P. O. Box 8555 Philadelphia 1, Pennsylvania ATTN: K. Wau	77	New York University Department of Aero Engineering University Heights New York 53, New York ATTN: L. Arnold	87
Heliodyne Corporation 2365 Westwood Boulevard Los Angeles, California ATTN: S. Feldman	78	North American Aviation Space and Information Systems Division 12214 Lakewood Boulevard Downey, California ATTN: E. Allen	88

DISTRIBUTION LIST (concluded)

<u>Recipient</u>	<u>Copy No.</u>	<u>Recipient</u>	<u>Copy No.</u>
Purdue University School of Aero and Engineering Sciences LaFayette, Indiana ATTN: I. Kvakovsky	89	The John Hopkins University Applied Physics Laboratory 8621 Georgia Avenue Silver Springs, Maryland ATTN: G. Seielstad	100
Princeton University Princeton, New Jersey ATTN: Prof. E. Frieman	90	University of California San Diego, California	
ATTN: Prof. S. Bogdonoff	91	ATTN: Prof. N. M. Kroll	101
Rome Air Development Center Griffiss Air Force Base Rome, New York ATTN: P. Sandler	92	University of California Lawrence Radiation Laboratory Livermore, California ATTN: C. Craig	102
Radio Corporation of America Missiles and Surface Radar Division Moorestown, New Jersey ATTN: A. Gold	93	University of Chicago Laboratories for Applied Science Chicago 37, Illinois ATTN: L. M. Biberman	103
Raytheon Manufacturing Company Missile Systems Division Bedford, Massachusetts ATTN: I. Britton, Librarian	94	University of Michigan Ann Arbor, Michigan ATTN: Prof. K. M. Case	104
Space Technology Laboratories 1 Space Park Redondo Beach, California ATTN: Leslie Hromas	95	University of Michigan Willow Run Laboratories P. O. Box 2008 Ann Arbor, Michigan ATTN: BAMIRAC/B. R. George	105
Space Technology Laboratories, Inc. P. O. Box 95001 Los Angeles 45, California ATTN: L. McFadden	96	University of Michigan Radiation Laboratory 201 Catherine Ann Arbor, Michigan	106
Sylvania Elec. Products Applied Physics Laboratory Waltham, Massachusetts ATTN: R. Row	97	U. S. Air Force Ballistic Missile Division AF Unit Post Office Los Angeles 45, California ATTN: Major R. Fowler/WDTVP	107
Stanford Research Institute Menlo Park, California ATTN: Acquisitions	98	U. S. Army Liaison Office Canadian Armament Res and Dev Establishment P. O. Box 1427 Quebec, P. Q., Canada	
The Rand Corporation 1700 Main Street Santa Monica, California ATTN: Mary Romig	99	ATTN: Lt Col E. W. Kreisler	108
		GM Defense Research Laboratories	109 and above

GM Defense Research Laboratories, General Motors Corp., Santa Barbara, Calif.

MILLIMETER WAVELENGTH FOCUSED PROBES AND FOCUSED, RESONANT PROBES FOR USE IN STUDYING IONIZED WAKES BEHIND HYPERSONIC VELOCITY PROJECTILES, by R. I. Primich and R. A. Hayami. TR63-217C. July 1963. 51p. illus. & tables.

Strongly focused microwave beams are being used as a plasma diagnostics tool in the determination of the magnitude and spatial distribution of ionization behind projectiles fired at hypersonic velocities into the controlled atmosphere of a flight physics range. The importance of millimeter wavelength

GM Defense Research Laboratories, General Motors Corp., Santa Barbara, Calif.

MILLIMETER WAVELENGTH FOCUSED PROBES AND FOCUSED, RESONANT PROBES FOR USE IN STUDYING IONIZED WAKES BEHIND HYPERSONIC VELOCITY PROJECTILES, by R. I. Primich and R. A. Hayami. TR63-217C. July 1963. 51p. illus. & tables.

Strongly focused microwave beams are being used as a plasma diagnostics tool in the determination of the magnitude and spatial distribution of ionization behind projectiles fired at hypersonic velocities into the controlled atmosphere of a flight physics range. The importance of millimeter wavelength

GM Defense Research Laboratories, General Motors Corp., Santa Barbara, Calif.

MILLIMETER WAVELENGTH FOCUSED PROBES AND FOCUSED, RESONANT PROBES FOR USE IN STUDYING IONIZED WAKES BEHIND HYPERSONIC VELOCITY PROJECTILES, by R. I. Primich and R. A. Hayami. TR63-217C. July 1963. 51p. illus. & tables.

Strongly focused microwave beams are being used as a plasma diagnostics tool in the determination of the magnitude and spatial distribution of ionization behind projectiles fired at hypersonic velocities into the controlled atmosphere of a flight physics range. The importance of millimeter wavelength

GM Defense Research Laboratories, General Motors Corp., Santa Barbara, Calif.

MILLIMETER WAVELENGTH FOCUSED PROBES AND FOCUSED, RESONANT PROBES FOR USE IN STUDYING IONIZED WAKES BEHIND HYPERSONIC VELOCITY PROJECTILES, by R. I. Primich and R. A. Hayami. TR63-217C. July 1963. 51p. illus. & tables.

Strongly focused microwave beams are being used as a plasma diagnostics tool in the determination of the magnitude and spatial distribution of ionization behind projectiles fired at hypersonic velocities into the controlled atmosphere of a flight physics range. The importance of millimeter wavelength

1. Microwave equipment - Application
 2. Hypervelocity projectiles-ionizing effect
 3. Hypervelocity projectiles-Wakes
 4. Plasma physics
- I DA-04-495-ORD-3567(Z)
II TR63-217C
III Primich, R. I.
IV Hayami, R. A.
(Descriptors) Millimeter waves, microwave equipment, plasma physics, gas ionization, hypervelocity guns, hypervelocity projectiles, radar equipment, radar, wake, wake detectors

1. Microwave equipment - Application
 2. Hypervelocity projectiles-ionizing effect
 3. Hypervelocity projectiles-Wakes
 4. Plasma physics
- I DA-04-495-ORD-3567(Z)
II TR63-217C
III Primich, R. I.
IV Hayami, R. A.
(Descriptors) Millimeter waves, microwave equipment, plasma physics, gas ionization, hypervelocity guns, hypervelocity projectiles, radar equipment, radar, wake, wake detectors

techniques for this purpose is stressed. The design philosophy of focused plasma probes is outlined and specific details of 35 and 70 Gc probes are given, together with some typical results. The conversion of such a probe into a free-space resonator in which the resolution is preserved, but in which the sensitivity is greatly improved, is discussed and some preliminary results are given.

techniques for this purpose is stressed. The design philosophy of focused plasma probes is outlined and specific details of 35 and 70 Gc probes are given, together with some typical results. The conversion of such a probe into a free-space resonator in which the resolution is preserved, but in which the sensitivity is greatly improved, is discussed and some preliminary results are given.

techniques for this purpose is stressed. The design philosophy of focused plasma probes is outlined and specific details of 35 and 70 Gc probes are given, together with some typical results. The conversion of such a probe into a free-space resonator in which the resolution is preserved, but in which the sensitivity is greatly improved, is discussed and some preliminary results are given.

techniques for this purpose is stressed. The design philosophy of focused plasma probes is outlined and specific details of 35 and 70 Gc probes are given, together with some typical results. The conversion of such a probe into a free-space resonator in which the resolution is preserved, but in which the sensitivity is greatly improved, is discussed and some preliminary results are given.

GM Defense Research Laboratories, General Motors Corp., Santa Barbara, Calif.

MILLIMETER WAVELENGTH FOCUSED PROBES AND FOCUSED, RESONANT PROBES FOR USE IN STUDYING IONIZED WAKES BEHIND HYPERSONIC VELOCITY PROJECTILES, by R. I. Primich and R. A. Hayami. TR63-217C. July 1963. 51p. illus. & tables.

Strongly focused microwave beams are being used as a plasma diagnostics tool in the determination of the magnitude and spatial distribution of ionization behind projectiles fired at hypersonic velocities into the controlled atmosphere of a flight physics range. The importance of millimeter wavelength

1. Microwave equipment - Application
2. Hypervelocity projectiles-ionizing effect
3. Hypervelocity projectiles-Wakes
4. Plasma physics
I DA-04-495-ORD-3567(Z)
II TR63-217C
III Primich, R. I.
IV Hayami, R. A.
(Descriptors) Millimeter waves, microwave equipment, plasma physics, gas ionization, hypervelocity guns, hypervelocity projectiles, radar equipment, radar, wake, wake detectors

GM Defense Research Laboratories, General Motors Corp., Santa Barbara, Calif.

MILLIMETER WAVELENGTH FOCUSED PROBES AND FOCUSED, RESONANT PROBES FOR USE IN STUDYING IONIZED WAKES BEHIND HYPERSONIC VELOCITY PROJECTILES, by R. I. Primich and R. A. Hayami. TR63-217C. July 1963. 51p. illus. & tables.

Strongly focused microwave beams are being used as a plasma diagnostics tool in the determination of the magnitude and spatial distribution of ionization behind projectiles fired at hypersonic velocities into the controlled atmosphere of a flight physics range. The importance of millimeter wavelength

GM Defense Research Laboratories, General Motors Corp., Santa Barbara, Calif.

MILLIMETER WAVELENGTH FOCUSED PROBES AND FOCUSED, RESONANT PROBES FOR USE IN STUDYING IONIZED WAKES BEHIND HYPERSONIC VELOCITY PROJECTILES, by R. I. Primich and R. A. Hayami. TR63-217C. July 1963. 51p. illus. & tables.

Strongly focused microwave beams are being used as a plasma diagnostics tool in the determination of the magnitude and spatial distribution of ionization behind projectiles fired at hypersonic velocities into the controlled atmosphere of a flight physics range. The importance of millimeter wavelength

1. Microwave equipment - Application
2. Hypervelocity projectiles-ionizing effect
3. Hypervelocity projectiles-Wakes
4. Plasma physics
I DA-04-495-ORD-3567(Z)
II TR63-217C
III Primich, R. I.
IV Hayami, R. A.
(Descriptors) Millimeter waves, microwave equipment, plasma physics, gas ionization, hypervelocity guns, hypervelocity projectiles, radar equipment, radar, wake, wake detectors

GM Defense Research Laboratories, General Motors Corp., Santa Barbara, Calif.

MILLIMETER WAVELENGTH FOCUSED PROBES AND FOCUSED, RESONANT PROBES FOR USE IN STUDYING IONIZED WAKES BEHIND HYPERSONIC VELOCITY PROJECTILES, by R. I. Primich and R. A. Hayami. TR63-217C. July 1963. 51p. illus. & tables.

Strongly focused microwave beams are being used as a plasma diagnostics tool in the determination of the magnitude and spatial distribution of ionization behind projectiles fired at hypersonic velocities into the controlled atmosphere of a flight physics range. The importance of millimeter wavelength

1. Microwave equipment - Application
2. Hypervelocity projectiles-ionizing effect
3. Hypervelocity projectiles-Wakes
4. Plasma physics
I DA-04-495-ORD-3567(Z)
II TR63-217C
III Primich, R. I.
IV Hayami, R. A.
(Descriptors) Millimeter waves, microwave equipment, plasma physics, gas ionization, hypervelocity guns, hypervelocity projectiles, radar equipment, radar, wake, wake detectors

1. Microwave equipment - Application
2. Hypervelocity projectiles-ionizing effect
3. Hypervelocity projectiles-Wakes
4. Plasma physics
I DA-04-495-ORD-3567(Z)
II TR63-217C
III Primich, R. I.
IV Hayami, R. A.
(Descriptors) Millimeter waves, microwave equipment, plasma physics, gas ionization, hypervelocity guns, hypervelocity projectiles, radar equipment, radar, wake, wake detectors

techniques for this purpose is stressed. The design philosophy of focused plasma probes is outlined and specific details of 35 and 70 Gc probes are given, together with some typical results. The conversion of such a probe into a free-space resonator in which the resolution is preserved, but in which the sensitivity is greatly improved, is discussed and some preliminary results are given.

techniques for this purpose is stressed. The design philosophy of focused plasma probes is outlined and specific details of 35 and 70 Gc probes are given, together with some typical results. The conversion of such a probe into a free-space resonator in which the resolution is preserved, but in which the sensitivity is greatly improved, is discussed and some preliminary results are given.

techniques for this purpose is stressed. The design philosophy of focused plasma probes is outlined and specific details of 35 and 70 Gc probes are given, together with some typical results. The conversion of such a probe into a free-space resonator in which the resolution is preserved, but in which the sensitivity is greatly improved, is discussed and some preliminary results are given.

techniques for this purpose is stressed. The design philosophy of focused plasma probes is outlined and specific details of 35 and 70 Gc probes are given, together with some typical results. The conversion of such a probe into a free-space resonator in which the resolution is preserved, but in which the sensitivity is greatly improved, is discussed and some preliminary results are given.

UNCLASSIFIED

UNCLASSIFIED