

UNCLASSIFIED

AD

413823

DEFENSE DOCUMENTATION CENTER

FOR

SCIENTIFIC AND TECHNICAL INFORMATION

CAMERON STATION, ALEXANDRIA, VIRGINIA



UNCLASSIFIED

NOTICE: When government or other drawings, specifications or other data are used for any purpose other than in connection with a definitely related government procurement operation, the U. S. Government thereby incurs no responsibility, nor any obligation whatsoever; and the fact that the Government may have formulated, furnished, or in any way supplied the said drawings, specifications, or other data is not to be regarded by implication or otherwise as in any manner licensing the holder or any other person or corporation, or conveying any rights or permission to manufacture, use or sell any patented invention that may in any way be related thereto.

63-4-4
20 August 1963

CATALOGED BY DDC
413823
AS AD No. _____

RADC TDR- 63-312

ASTIA Document No.

ARCHITECTURAL
INTERFERENCE DATA

White Electromagnetics, Inc.
4903 Auburn Avenue
Bethesda 14, Maryland

Final Report
AF 30(602)-2691
Project Number 4540
Task Number 454003

Prepared for

Headquarters,
Rome Air Development Center
Research & Technology Division
Air Force Systems Command
United States Air Force
Griffiss Air Force Base
New York

413823

DDC
RECEIVED
AUG 22 1963
TISIA D

Qualified requesters may obtain copies from ASTIA. Orders will be expedited if placed through the librarian or other persons designated to request documents from ASTIA.

When U.S. Government drawings, specifications, or other data are used for any purpose other than a definitely related government procurement operation, the government thereby incurs no responsibility nor any obligation whatsoever; and the fact that the government may have formulated, furnished, or in any way supplied the said otherwise, as in any manner licensing the holder or any other person or corporation, or conveying any rights or permission to manufacture, use, or sell any patented invention that may in any way be related thereto.

20 August 1963

RADC TDR- 63-312

ASTIA Document No.

ARCHITECTURAL
INTERFERENCE DATA

White Electromagnetics, Inc.
4903 Auburn Avenue
Bethesda 14, Maryland

Final Report
AF 30(602)-2691
Project Number 4540
Task Number 454003

Prepared for

Headquarters,
Rome Air Development Center
Research & Technology Division
Air Force Systems Command
United States Air Force
Griffiss Air Force Base
New York

FOREWORD

This report constitutes the Final Report pertaining to "Architectural Interference Data" which is an extension of an initial program concerning the "Study of Interference Problems Due to Structures in High RF Fields."

The study was sponsored by Rome Air Development Center (AFSC), Contract Number AF 30(602)-2691 under Project Number 4540, Task Number 454003. Technical monitoring was under the cognizance of Mr. Robert Powers of the Electromagnetic Vulnerability Laboratory.

Problems which are associated with the generation of electromagnetic interference by building structures (such as corona discharge, harmonic generation, corrosion, bonding impedance, lightning discharges, grid and rodbed ground impedance and reference plane impedance) are studied and criteria is developed relative to preferred construction techniques necessary to minimize such effects.

ABSTRACT

The increased usage of high-powered transmitters has made the existence of high RF fields more commonplace. This report covers the results of an investigation of the primary problems of bonding, shielding and grounding as related to potential interference phenomena such as corona, lightning, and harmonic generation. This report is presented in the form of a handbook which provides specific structural design which should be utilized to minimize interference associated with structures. Design recommendations are based upon (1) final results of the initial study conducted under AF 30(602)-2691, (2) evaluation of available literature relative to the various problem areas, and (3) investigations of the contractor in problem areas which are inadequately covered by existing literature or the initial study program.

The handbook material is presented in two major sections: (1) Construction above Ground, and (2) Construction below Ground. The areas discussed in the first section are (1) background and recommended criteria for preferred bonding techniques to minimize impedance, corrosion, harmonic generation and corona, (2) recommended techniques to minimize undesired effects to lightning discharge, (3) treatment of structural members to preclude corrosion and corona effects, and (4) shielding effectiveness of various construction materials and recommended techniques for utilization in structure design.

The areas discussed in the section "Construction Below Ground" are (1) recommendations relative to optimum usage of ground rods and earth ground grid meshes, (2) recommendations of techniques for designing and implementing reference ground plane grid meshes, and (3) illustrations of design problems including a typical structure incorporating recommended grounding techniques.

Recommendations developed as a result of this study are presented covering the areas of Bond Impedance, Harmonic Generation, Corona Discharge, Lightning Discharge, EM Shielding, Ground Rods, Ground Grid Meshes and Reference Plane Ground Grid Meshes.

Title of Report RADC-TDR-63-312

PUBLICATION REVIEW

This report has been reviewed and is approved.

Approved: *Robert Powers*
ROBERT POWERS, Chief
Interference Reduction Branch
Electromagnetic Vulnerability Lab

Approved: *Samuel D. Zaccari*
SAMUEL D. ZACCARI, Chief
Electromagnetic Vulnerability Lab
Directorate of Communications

FOR THE COMMANDER:

Irving J. Gabelman
IRVING J. GABELMAN
Director of Advanced Studies

TABLE OF CONTENTS

	PAGE
FOREWORD	i
ABSTRACT	ii
TABLE OF CONTENTS	iv
LIST OF ILLUSTRATIONS	vii
LIST OF TABLES	xii
1. INTRODUCTION	1
1.1 Purpose of the Notebook	1
1.2 Contents of Notebook	1
2. CONSTRUCTION ABOVE GROUND	4
2.1 Bonding Criteria	4
2.1.1 Evaluation of Specific Bonding Techniques Relative to Minimizing Interference Generating Properties	4
2.1.1.1 Direct and Inherently Bonded Joints	6
2.1.1.1.1 Measurements of Bonds between Resonant Plates	7
2.1.1.2 Indirect Bonded Joints	10
2.1.1.3 Harmonic Generation and Corona	14
2.1.1.3.1 Harmonic Generation	14
2.1.1.3.2 Corona	17
2.1.1.4 Some Facets of Corrosion	18
2.1.2 Specific Bonding Recommendations Relative to (1) Reduction in Impedance, (2) Reduction of Har- monic Generation and Corona, and (3) Corrosion Resistance	29
2.1.2.1 As Applicable to Structure Usage	36
2.2 Interference and Hazards of Lightning Discharges	38
2.2.1 Antenna Structures and Support Structures	39
2.2.1.1 Guyed Structures	41
2.2.2 Recommendations to Preclude Interference and Hazardous Aspects of Lightning Discharges	41
2.3 Surface Treatment to Preclude Interference Effects	43
2.3.1 Paint Life Expectancy	44
2.3.2 Treatment of Irregularities	45
2.4 Complimentary Construction Techniques Relative to the Attenuation of Electromagnetic Energy	45
2.4.1 Attenuation Properties of Construction Materials	46
2.4.2 Conductive Meshes in Walls, Floors, and Ceilings	48
2.4.3 Metallic Wallpaper	48
2.4.4 Door and Window Design for Electromagnetic Field Attenuation	52

	PAGE
3. CONSTRUCTION BELOW GROUND	54
3.1 Ground Rods and Earth Ground Grid Meshes	55
3.1.1 State-of-the-Art Earth Grounding Techniques	55
3.1.2 Design of Grounding System Utilizing Ground Rods	56
3.1.3 Materials to be Used in Ground Rods, Size and Coatings	61
3.1.4 Methods for Connecting Ground Rod to Structure and Grid Mesh	64
3.1.5 Terrain Considerations	66
3.1.6 Methods for Approximating Soil Resistivity	75
3.1.7 Design of Grounding System Utilizing Ground Grid Mesh	83
3.1.7.1 Method for Determining Optimum Dimensions of Earth Ground Grid Mesh	83
3.1.8 Method for Connecting Earth Ground Grid Mesh to Structure	88
3.1.9 Method for Approximating Combined Ground Resistance of Mesh and Ground Rods	88
3.2 Reference Plane Ground Grid	91
3.2.1 Determination of Optimum Physical Grid Dimensions as a Function of Impedance Requirements, and Foundation Area	91
3.2.2 Materials to be Used, Size Requirements, Coatings and Methods of Bonding Joints	104
3.2.3 Methods of Physically Implementing Reference Plane Ground Grid Mesh	105
3.2.4 Method for Connecting Reference Plane Ground Grid Mesh to Earth Ground	109
4. CONCLUSIONS AND RECOMMENDATIONS	111
4.1 Bond Impedance	111
4.2 Harmonic Generation	111
4.3 Corona Discharge	112
4.4 Lightning Discharge	112
4.5 Electromagnetic Shielding	112
4.6 Ground Rods	113
4.7 Earth Ground Grid Meshes	113
4.8 Reference Plane Ground Grid Meshes	114
BIBLIOGRAPHY	
Appendix I - Derivations of Ground Resistance Realized by Rodbeds and Grid Meshes	I-1
Appendix II - Derivation of Conductivity by Four-Point Method	II-1
Appendix III - Derivation for Maximum Resistance of Square Grid Mesh	III-1

	PAGE
Appendix IV - Derivation for Maximum Resistance of Rectangular Grid Mesh	IV-1
Appendix V - Metallic Wallpaper	V-1

LIST OF ILLUSTRATIONS

<u>Figure No.</u>	<u>Title</u>	<u>Page</u>
1	Schematic Representation of Direct Bond	6
2	Magnitude of Impedance of a Parallel Circuit as a Function of: (A) Frequency, (B) Inductance, and (C) Capacity.	8
3	Magnitude of Impedance of a Parallel Circuit as a Function of Frequency for Two different Values of the LC product.	8
4	Solid Rectangular Bond Strap	11
5	Self-Inductance vs. Length/Width Ratio of Rectangular Bar	13
6	Plot of AC Resistance vs. Width to Thickness Ratio of Rectangular Bar	15
7	Galvanic Corrosion	20
8	Corrosion Fatigue	21
9	Crevice Corrosion	22
10	Stress Corrosion	23
11	Connection of Dissimilar Metals	24
12	Welding To Avoid Excessive Heating	25
13	Corrosion Prevention by Usage of Welding	26
14	Usage of Hexagonal and Palnuts	30
15	Techniques for Bonding Metallic Members Connected by Rivets.	31
16	Preferred Lock Washers Usage	34
17	Techniques for Minimizing Harmonic Generation and Corona	37
18	Grounding Arrangement - Fixed Building and Antenna Foundation	40
19	Plane Wave Measurements of S for Construction Materials.	47

<u>Figure No.</u>	<u>Title</u>	<u>Page</u>
20	Low Impedance (H or Magnetic) Field Measurements of S for Screen Materials	49
21	High Impedance (E or Electric) Field Measurements of S For Screen Materials	50
22	Reinforcement Bar Tie-In	51
23	Method of Bonding Between Door and Structure	53
24	Values of Coefficient k_1 as Function of Length to Width Ratio X of Area.	57
25	Ground Resistance vs. Number of Evenly- Spaced Parallel Ground Rods. For Various Areas of Coverage and Depths of Earth Penetration	58
26	Physical Characteristics of Typical Ground Rods.	62
27	Method for Connecting Ground Rods to Structure and Grid Mesh	65
28	Grounding at Foundation of Guyed Tower	67
29	Grounding at Anchor of Guyed Tower	68
30	Ground Connection at Base Shoe for Self-Supporting Towers	69
31	Distribution of Current About a Metallic Hemispherical Ground Electrode of Radius a. Arrows Indicate Lines of Current Flow	70
32	Resistivity of Red Clay Soil Drops Rapidly as its Moisture Content Increases to About 15% by Weight	72
33	Resistivity of Red Clay Soil Diminished as Temperature Rises in a Sample Containing 18.6% Moisture.	73

<u>Figure No.</u>	<u>Title</u>	<u>Page</u>
34	Effect of Addition of Salt Upon Resistivity of Red Clay Soil	74
35	Changes in Resistance of a Ground Connection in Response to Presence of Salt over a Considerable Period	74
36	Fall-of-Potential Ground-Resistance Measurement uses Ammeter, Voltmeter and AC Power Source, or Self-Contained Automatically-Compensated Ground Tester.	76
37	Four-Point Array	78
38	Wenner Array	80
39	Eltran Array	80
40	Wait Array	80
41	Values of Coefficient k_2 Corresponding to Coefficient k_1	84
42	Ground Resistance vs. Number of Grids in Mesh as a Function of Total Mesh Area	85 a
43	Ground Resistance vs. Grid Mesh Area	86
44	Method for Connecting Earth Ground Grid Mesh to Structure	89
45	Typical Combination of Ground Rods and Grid Mesh	90
46	Hypothetical Application of Reference Plane Grid Mesh	92
47	Maximum DC Grid Resistance and Self- Inductance of Grid vs. Number of Grids per Side and Total Grid Area (1.0 in. copper cable)	94
48	Maximum DC Grid Resistance and Self-Inductance of Grid vs. Number of Grids per Side and Total Grid area (3/4 in. copper cable)	95

<u>Figure No.</u>	<u>Title</u>	<u>Page</u>
49	Maximum DC Grid Resistance and Self -Inductance of Grid vs. Number of Grids per side and Total Grid Area (4/0 Copper Cable)	96
50	Plot of Maximum Resistance vs. Number of Grids on Short Side of Rectangular Ground Grid Mesh 1/w = 2, 1" Copper Cable.	100
51	Plot of Maximum Resistance vs. Number of Grids on Short Side of Rectangular Ground Grid Mesh 1/w = 2, 4/0 Copper Cable	101
52	Plot of Maximum Resistance vs. Number of Grids on Short Side of Rectangular Ground Grid Mesh 1/w = 3 1" Copper Cable	102
53	Plot of Maximum Resistance vs. Number of Grids on Short Side of Rectangular Ground Grid Mesh 1/w = 3 4/0 Copper Cable.	103
54	Graph For Determining K Factors.	107
55	Techniques For Implementing Jumpers to the Reference Plane of a Multi-Story Building.	108
56	Method for Connecting Reference Plane Ground Grid Mesh to Earth Ground	110
I-1	Mutual Influence of Two Systems (Images Omitted)	I-4
I-2	Straight Horizontal Wire with Arbitrarily Located Rods Attached.	I-4
I-3	Additive Term (N-1) for Rectangular Loops of Various Length to Depth Ratio X.	I-8
I-4	Arrangement of n Equally-Spaced Ground Rods in a Square Area	I-9
I-5	Arrangement of Four Rods at Corners of a Square.	I-9
III-1	Grid Constructed of Three Evenly-Spaced Grids Per Side.	III-1
III-2	Electrical Diagram	III-2

<u>Figure</u>	<u>Title</u>	<u>Page</u>
III-3	Simplified Electrical Diagram of Grid Mesh	III-2
IV-1	Typical Rectangular Grid Mesh	IV-1
IV-2	Schematic Diagram of Rectangular Grid Mesh	IV-2

LIST OF TABLES

Table I	Impedance Measurements of Bonds	9
Table II	Optimum Physical Dimensions of Rectangular Bond Strap Relative to Minimum Self-Inductance and AC Resistance	16
Table III	Galvanic Series of Metals	19
Table IV	Metal Connections	35
Table V	Metal Corrosivity as a Function of Soil Resistivity	63
Table VI	Electromotive Force Series for Metals	64
Table VII	The Resistivity of Different Soils	70
Table VIII	The Effect of Moisture Content on the Resistivity of Soil	72
Table IX	The Effect of Temperature on the Resistivity of Soil	73
Table X	The Effect of Salt Content on the Resistivity of Soil	75
Table III-1	Computed Values of Coefficient "k"	III -4

1. INTRODUCTION.

The increased usage of high-powered transmitters has made the existence of high RF fields more commonplace. The presence of structures in such fields gives rise to the possibility of various types of interference problems. These problems may be classified into two categories: (1) structural reradiation and (2) structural attenuation.

Structural reradiation problems may include dielectric breakdown (corona), harmonic generation, reflection and radiation hazards to personnel and electroexplosive devices (EED's). Structural attenuation problems in high RF fields include implementation of effective shielding techniques and compatible grounding systems during construction procedures. This notebook includes the results of the investigation and provides recommendations for construction techniques necessary to preclude or minimize problems associated with structural reradiation and attenuation problems. Basic problem areas that are discussed include: (1) study and recommendations of preferred bonding techniques to minimize impedance, corrosion, harmonic generation and corona, (2) study and recommendations of preferred techniques to minimize undesired effects due to lightning discharges, (3) treatment of structural members to preclude corrosion and corona effects, (4) study of shielding effectiveness of various materials and recommended techniques for implementation in structure design, (5) investigation and recommendations relative to optimum usage of ground rods and earth ground grid meshes, (6) study and recommendation relative to optimum design and implementation of reference plane ground grid meshes, and (7) a hypothetical illustration of a typical structure utilizing final recommended grounding techniques.

1.1 Purpose of the Notebook.

C-E equipment is becoming more sensitive and the operational environment or electromagnetic ambient of these equipments is increasing in level. Also the greater reliance being placed on electronic devices has increased the equipment density which compounds colocation problems and increases the potential for interference to occur. A continuing effort in the field of Electromagnetic Compatibility has been directed toward establishing interference design criteria for individual equipments. However, little concerted work has been directed toward considering the various effects of the structures which house or support these equipments. The design and building of these structures from an interference viewpoint has

been primarily an art developed through long experience and utilizing many "rules of thumb". The investigation, whose results are presented in this notebook, was directed toward establishing valid criteria for the interference design of structures.

This report is presented in notebook form because it was felt that this basic document could be used as a reference by those engineers confronted with structural interference problems and could be updated as more quantitative information becomes available. The material presented herein is not a panacea but is a beginning. As pointed out in the recommendation section, there is considerably more work to be done since in certain cases criteria are presented which are qualitative and have not been substantiated under controlled experimental conditions. These qualitative techniques were included where they have been proven to be effective through long usage.

1.2 Contents of Notebook.

The material presented in this notebook is a compilation of (1) the final results of the initial study and investigation of the interference problems of structures located in high RF fields¹ (2) evaluation of available literature relative to the various problem areas and (3) investigation by this contractor in problem areas which were not adequately covered by available literature or the initial study program. While there has not been a concerted effort in the field of RFI per se relative to interference criteria for structures, many different fields or specialized technologies have dealt in detail with various aspects of the total problem. These include soil engineers, electrical power engineers, construction engineers, in addition to interference engineers. The material in this notebook has drawn heavily from these sources in an effort to provide as complete a document as possible. A comprehensive bibliography is also included to provide the user of this document with the source material if further detail is required for a particular problem.

The notebook is presented in two major sections: (1) Construction Above Ground, and (2) Construction Below Ground.

Construction Above Ground covers the following material:

(1) Bonding Criteria.

¹ "Interference Problems Due To Structures in High RF Fields".

(a) Prediction and Evaluation of Specific Techniques to Reduce Interference-Generating Properties of Bonding Media

(b) Specific Bonding Recommendations Relative to:
(1) Reduction in Impedance, (2) Reduction of Harmonic Generation and Corona and (3) Corrosion Resistance.

(2) Interference and Hazards of Lightning Discharges

(3) Surface Treatment to Preclude Interference Effects

(4) Complimentary Construction Techniques Relative to the Attenuation of EM Energy.

Construction Below Ground covers the following:

(1) Ground Rods and Earth Ground Grid Meshes

(a) Methods of Determining the Number of Ground Rods, Depth of Penetration and Spacing as a Function of Building Foundation Areas

(b) Methods for Connecting Ground Rods to Structures and Grid Mesh

(c) Methods for Approximating Soil Resistivity

(d) Method for Determining Optimum Dimensions of Earth Ground Grid Mesh.

(e) Method for Connecting Earth Ground Grid Mesh to Structure

(f) Method for Approximating Combined Ground Resistance of Mesh and Ground Rods.

(2) Reference Plane Ground Grid.

(a) Determination of Optimum Physical Grid Dimensions.

(b) Methods of Physically Implementing Reference Plane Ground Grid.

(c) Method for Connecting Reference Plane Ground Grid to Earth Ground.

2. CONSTRUCTION ABOVE GROUND.

This section discusses problems associated with building construction above ground which are known sources of electromagnetic interference. Information relative to such problem areas, is analyzed and recommendations are presented to minimize such interference. Basic problem areas which are considered in this section are: (1) study and recommendations of preferred bonding techniques to minimize impedance, corrosion, harmonic generation and corona, (2) study and recommendations of preferred techniques to minimize undesired effects of lightning discharges, (3) treatment of structural members to preclude corrosion and corona effects, and (4) a study of shielding materials and recommended techniques for implementation in structure design.

2.1 Bonding Criteria.

The importance of equipotential ground planes cannot be overemphasized for proper equipment operation, RFI suppression, and personnel safety. An equipotential ground plane implies a mass, or masses, of conducting media which, when bonded together, offers a negligible impedance to current flow. A single connection between conducting media which offers a significant impedance to current flow, can place an entire grounding system at a high potential with respect to ground, so as to render all shielding media connected to the system completely ineffective. When such a high impedance connection is inserted in metallic members subject to large amounts of current due to lightning or power system fault currents, resultant potentials, with respect to ground, can be extremely hazardous to personnel and equipment. Oxides may form at mating surfaces of metallic media as a result of environmental conditions or electrolysis action which will greatly increase the impedance of the bond and form non-linear systems capable of generating and radiating various harmonic signals.

To preclude degenerative and hazardous effects of high impedance bonds, many effective bonding techniques have been recommended by numerous sources. To insure that bonding techniques are adequate, properly implemented, and remain effective with wear, compatible test procedures and limitations must be realized.

2.1.1 Evaluation of Specific Bonding Techniques Relative to Minimizing Interference Generating Properties

This section will contain information derived from specifications, printed matter, and personnel experience, relative to the implementation of preferred bonding techniques.

Joints that are press-fitted or joined by screws of the self-tapping or sheet metal type cannot be relied upon to provide low impedance ratio frequency paths. Often where there is a need for relative motion between members that should be bonded, as in the case of shock mounts, a flexible metal strap can be used as a bonding agent.

Additional investigations are required to provide (1) the evaluation of recommended bonding techniques, (2) establishment of most practical and reliable bond impedance test procedures for laboratory and field usage, and (3) establishment of meaningful maximum impedance specifications for applicable bonding media.

Existing maximum acceptable bonding standards are generally based on a DC ohmic value. The impracticability of such standards is generally recognized but is accepted due to the existing void in RF impedance measurement techniques. It is to be expected that the RF impedance of a bond may be many times the magnitude of the DC resistance value at high frequencies.

Numerous techniques have been presented which purport to be effective RF impedance measuring techniques. Such techniques have been found to be limited by one or more of the following: (1) unreliable results due to the effects of standing waves, (2) unrepeatability of results, (3) insufficient segregation of bond impedance and instrumentation contact impedance, (4) test configurations much too elaborate and critical for practical field usage, (5) sensitivity of measuring apparatus inadequate to measure small voltage drops across bond impedance, and (6) current restrictions of reference components (micropotentiometers). Techniques that appear theoretically sound have been found to produce inaccurate or unrepeatable results. Bond impedance has been observed to vary drastically as a result of the points at which instrumentation contact is made on the test bond.

After bonding is implemented, no reliable assurance is available relative to the electrical quality of the final bond connection. Factors such as (1) non-conductive films between mating surfaces (oil, tarnish, paint, etc.), (2) insufficient or irregular contacting surface areas, and (3) poor quality connections (bad weld, loose rivets, or bolts, etc.), may increase the impedance of a bond and may or may not be apparent by observation or DC resistance measurements.

Bonding media must offer minimum RF impedance to current flow for the following reasons: (1) eliminate hazardous potentials that may be induced due to lightning or power fault currents, (2) reduce effects

of radiated and re-radiated signals from structural members, (3) reduce harmonic generation by corroded connections, and (4) provide low impedance reference plane for effective termination of shielding media.

2.1.1.1 Direct and Inherently Bonded Joints.

Direct bonding is accomplished by direct metal-to-metal contact between two surfaces under high and uniform unit pressure. If properly constructed, a bond of this type has a low ohmic resistance as well as a low RF impedance.

Bonds formed by direct metal-to-metal contact through mating surfaces held together by clamping devices may deteriorate with time^a. This is brought about by corrosive action which in time makes the bond ineffective by causing the contact impedance to increase beyond tolerable limits. Corrosive action may be either the galvanic or the electrolytic type or both depending on the nature of the metals in contact and on whether or not the metal-to-metal contact is part of a direct current circuit; but, both types of corrosion take place only when moisture is in contact with the mating surfaces. Section 2.1.1.4 presents a detailed discussion of the mechanics of corrosion.

The possibility of galvanic action or electrolytic action necessitates the use of extreme care in assembling joints which serve as bonds for the ground return path.

A bond can be represented schematically by the following circuit:

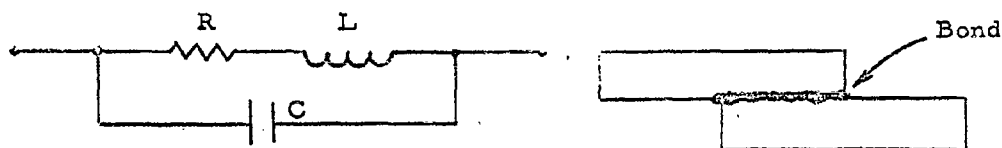

Figure 1. SCHEMATIC REPRESENTATION OF DIRECT BOND.

^a Ibid., page 2

where

- R = the ohmic resistance including skin effects,
- L = the series inductance of the bond,
- C = the distributed capacitance of the bond.

The effect of R is usually negligible except near the point of antiresonance. If the resistance is neglected the formula for the impedance, Z, of the equivalent circuit is given as:

$$|Z| = \frac{\omega L}{1 - \omega^2 LC} = \frac{1}{\omega C} \left[\frac{1}{1 - \frac{1}{\omega^2 LC}} \right] \quad 2(1)$$

where ω is the angular frequency. If $\omega^2 LC$ is less than one, the circuit operates below the antiresonant frequency and acts as an inductance. A decrease in values of capacitance or inductance, below the point where $\omega^2 LC$ equals one, results in a decrease of the impedance. If $\omega^2 LC$ is greater than one, the circuit is operated above the antiresonant frequency and acts as a capacitance. With an increase in capacitance or inductance the impedance decreases.

Therefore, to keep the ratio impedances low at frequencies below the antiresonant frequency the values of L and C must be comparatively low for a low LC product. At frequencies above the antiresonant frequency the values of L and C must be comparatively large to give a large LC product, to obtain a low value of impedance.

Figure 2 is a plot of the magnitude of impedance in a parallel circuit with various circuit junctions and Figure 3 is a plot of the magnitude of impedance of a parallel circuit as a function of frequency for different values of L and C.

2.1.1.1.1 Measurements of Bonds Between Resonant Plates.

Experiments were made using two elements of a half-wave dipole, joined by overlapping and assembly with a bolt, rivet, or weld. Two elements of a half-wave dipole, not overlapped, were joined by a piece of braid. The induced RF voltage, when the dipoles were placed in a high RF field, was to be measured across the bond. The RF impedance and DC resistance of each of the bonds were measured. The measuring points on all these test structures were located one inch apart.

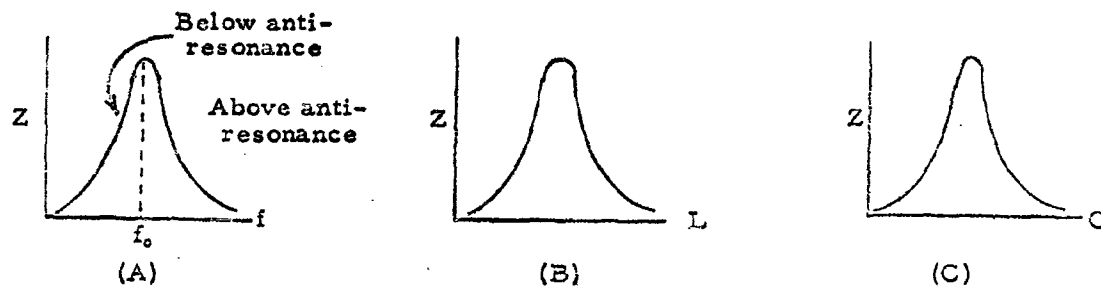

Figure 2. MAGNITUDE OF IMPEDANCE OF A PARALLEL CIRCUIT AS A FUNCTION OF: (A) Frequency, (B) Inductance, and (C) Capacity.

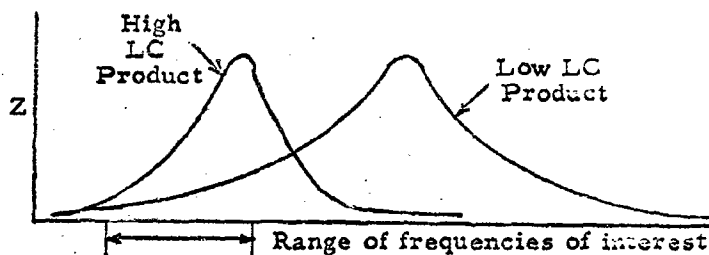

Figure 3. MAGNITUDE OF IMPEDANCE OF A PARALLEL CIRCUIT AS A FUNCTION OF FREQUENCY FOR TWO DIFFERENT VALUES OF THE LC PRODUCT.

The induced RF voltage was measured by placing the dipoles on a tripod 14 feet in front of the transmitting antenna and measuring the induced peak voltage with an NF-105 receiver. Because of the intense fields, the pickup in the lead-in cable and balun used at the dipole was measured under two conditions: the balun was terminated in 50 ohms, and then terminated in a short circuit. The cable pickup was a sizable voltage; however, for the case of the balun-terminated in a short circuit, the pickup voltage is considerably less than the induced voltage across the short on the dipole. The short on the dipole had a measured RF impedance of 10 - 14 ohms. The majority of the voltage reading using the dipoles would be due to the induced voltage from the dipoles and not to cable and balun pickup.

Test data is listed in Table I showing resultant impedances from the various bonding media. The bolted and welded joints offered the lowest impedance and the riveted joint offered the greatest.

Table I

Impedance Measurements of Bonds.
Material: Aluminum Dipole Panels,
Bonded.

Type of Bond*	RF Impedance (Ohms)	DC Impedance (Ohms)
Bolt (20 in. -lb.)	2.08 + j 10.25	0.05
Weld	2.08 + j 10.25	0.07
Braid	2.86 + j 8.58	0.07
Rivet	3.32 + j 12.45	0.1

* Bond types are listed in order of increasing magnitude of measured impedance.

The following recommendations are presented in a Navy Department, Bureau of Yards and Docks, Design Manual:

**Bonding Recommendations
For Specific Building Types***

Facility- Building	Bonding
Radio Transmitter...	All metal objects in the building, such as structural steel, ducts, cable trays, pipes and ventilators, shall be electrically bonded and grounded to the building electronic ground.
Radio receiver....	All metal objects in the building, such as structural steel, ducts, cable trays, pipes, and ventilators shall be electrically bonded and grounded to the building electronic ground.
Communication centers & Terminal Equipment...	<ol style="list-style-type: none"> 1. No bonding requirement for metal structural members, i. e., reinforcing steel, flashings and door frames. 2. Electrically bond copper grounding bus-bars to conduits, piping and cellular steel floors.

* Design Manual, DM-23, Communications, Navigational Aids and Airfield Lighting - Navy Department, Bureau of Yards and Docks.

2.1.1.2 Indirect Bonded Joints.

An intermediate element used to electrically connect two surfaces is considered as an indirect bond. Bonding jumpers are commonly used to establish indirect bonds between surfaces and their use should result in the lowest possible DC and RF impedance path between surfaces. Since bonding jumpers have significant RF impedance, their use should be avoided whenever possible. Bonding jumpers are also used to bond two surfaces that must be capable of movement; this would include expansion joints.

Bond straps should be selected so that their physical dimensions result in an optimum reduction of resultant impedance without impairment of mechanical requirements. Solid bond straps have been shown to exhibit

the least amount of impedance. Self-inductance is the major contributor to the impedance of a solid rectangular bond strap and the magnitude of the AC resistance is practically negligible.

The self-inductance of solid rectangular bond strap is approximately equal to the mutual inductance between two parallel straight filaments of the same length separated by a distance equal to the geometrical mean distance of the cross-section of the bar. Figure 4 illustrates a solid rectangular bond strap and pertinent dimensions. The self-inductance can be calculated in the following manner³:

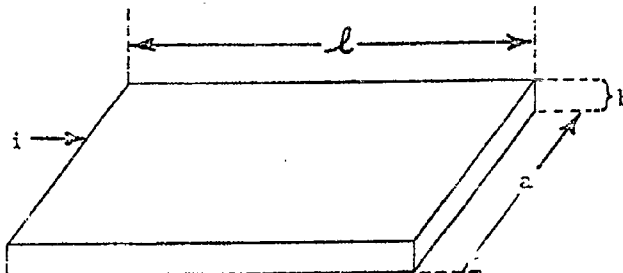

Figure 4. SOLID RECTANGULAR BOND STRAP

l = length b = thickness
 a = width i = direction of current flow.

$$M = 2 \left[l \log \frac{l + \sqrt{l^2 + d^2}}{d} - \sqrt{l^2 + d^2} + d \right] \times 10^{-9} \text{ (henries)} \quad 2(2)$$

where

M = mutual inductance between parallel straight filaments.
 l = length of filaments (cm.)
 d = distance between two filaments (cm.)

If: $l \gg d$

$$M \approx 2l \left[\log \frac{2l}{d} - 1 + \frac{d}{l} \right] \times 10^{-9} \text{ (henries)} \quad 2(3)$$

$$L \approx 2l \left[\log \frac{2l}{R} - 1 + \frac{R}{l} \right] \times 10^{-9} \text{ (henries)} \quad 2(4)$$

³ Formulas and Tables for the Calculation of Mutual and Self Inductance,
 E. B. Rosa and F. W. Grover, Vol. 8, No. 1, pp. 1-237, Jan. 1, 1912

where

R = geometrical mean distance of rod cross-section.
 $R \approx 0.2235 (a + b)$ (for all values of a & b)

Therefore:

$$L \approx 2l \log \frac{2l}{.2235 (a + b)} - 1 + \frac{.2235 (a + b)}{l} \times 10^{-9} \text{ (henries)} \quad 2(5)$$

For values of $l \gg d$

$$L \approx 2l \log \frac{l + \sqrt{l^2 + [.2235 (a + b)]^2}}{.2235 (a + b)} - \sqrt{l^2 + [.2235 (a + b)]^2} + .2235 (a + b) \times 10^{-9} \text{ (henries)} \quad 2(6)$$

Equation 2(6) is most adaptable for calculating the self-inductance since no simplifying assumptions have been made which will result in restriction of its usage as a result of physical dimensions. This equation has been used to calculate the self-inductance of a solid rectangular strap for length to width ratio (l/a) values of 0.1, 0.667, 0.5, 1.0, 5.0, and 10.0. The width (a) was held constant since it was desired to observe self-inductance variations as a function of l/a , and not as a function of cross-sectional area. Results of such calculations are presented graphically in Figure 5.

As previously stated, the AC resistance of a solid rectangular bond strap is much less than the reactance associated with self-inductance, however, it is desirable to observe the effects of such resistance so as to minimize its effects. The high frequency resistance of a solid rectangular bond strap (see Figure 4) can be calculated by the following formula:⁴

$$R = \frac{K(261)\sqrt{f}}{2(a + c)} \times 10^{-9} \text{ (henries)} \quad 2(7)$$

where

K = constant determined by a/c ratio.
f = frequency
a = width of bond strap (cm.)
c = thickness of bond strap (cm.)

⁴J. D. Corockraft, "Skin Effect in Rectangular Conductors at High Frequency", Proceedings of Royal Society (London), Vol. 122, No. A790, 0533, Feb 4, 1929.

L/W	L(henries)
10	18.692×10^{-9}
5	6.592×10^{-9}
1	$.264 \times 10^{-9}$
.5	$.01 \times 10^{-9}$
2	1.298×10^{-9}

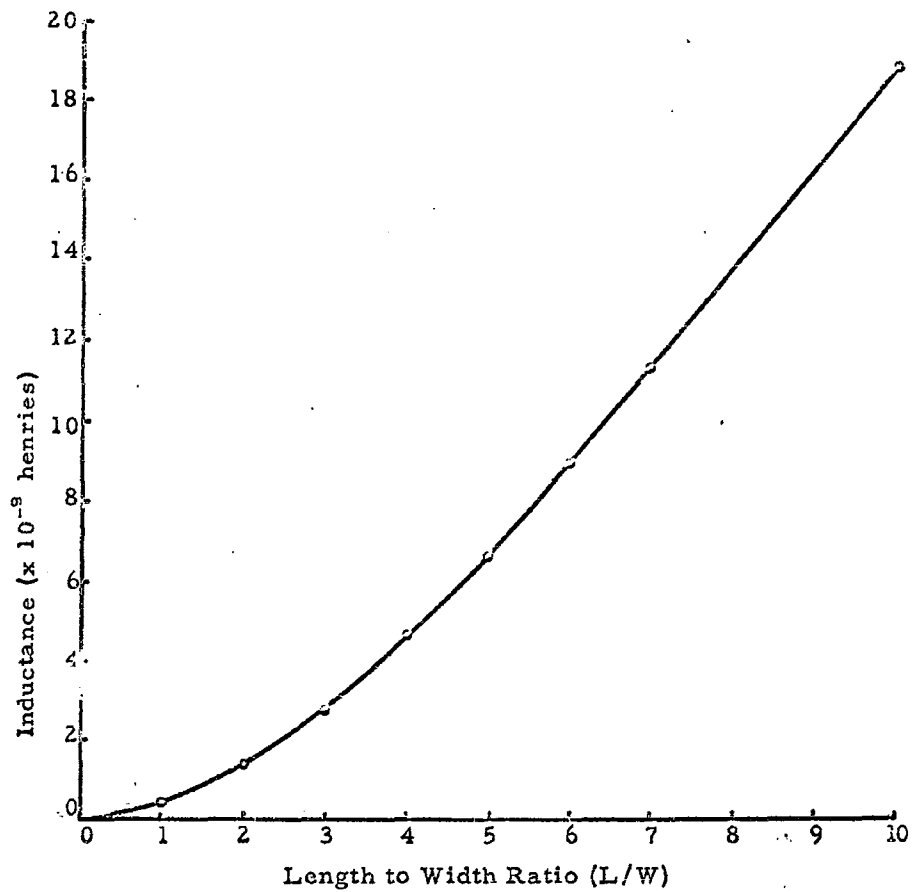

Figure 5-Self-Inductance vs. Length/Width Ratio of Rectangular Bar

It is desired to observe resistance changes as a function of width to thickness ratios (a/c) rather than changes resulting from variations in frequency. AC resistance has been calculated for width to thickness ratio (a/c) values of 1.0, 2.0, 5.0 and 10, using Equation 2(7). The term, $\sqrt{f} \times 10^{-9}$, has been considered as a constant and was not included in calculated values. Results of such calculations are presented graphically in Figure 6.

Figures 5 and 6 have been evaluated relative to predicting physical dimensions which will result in an optimum reduction of resultant self-inductance and AC resistance. Results of such evaluations are presented in Table II and related footnotes.

2.1.1.3 Harmonic Generation and Corona

During the course of a previous study program a problem was encountered which has significance in terms of RFI generated by structures in intense RF fields.

The problem is concerned with the suppression of harmonic generation due to "naturally" produced external non-linear systems, and the corona phenomenon. Both problems are indigenous to structures in high RF fields and the solution to suppressing these sources are much the same, preferably being accomplished during construction of the structure. When the recommendations at the end of this section are employed during construction then the cost of avoiding interference is certainly lessened.

2.1.1.3.1 Harmonic Generation.

Corrosive joints or bubbles in joints such as those found after "weather" coatings have been subjected to the elements for some time can produce oxides and corrosion products that are natural rectifiers, which will frequently pass current in one direction, better than the reverse. Although the efficiency of these "nature" devices is low, some types are excellent rectifiers. Lead sulphide was used as galena radio crystals in the early radio days, copper oxide and selenium under controlled conditions are used extensively throughout industry today for power rectification; all of these compounds can be found in weathered structures to some degree. If the material can pass current even slightly better in one direction than the other and the "circuit" arrangement is one in which RF energy is intercepted, processed, and radiated by structure members acting as antenna, then harmonic generation can take place and be radiated into space as a culprit RFI source generator. The strength

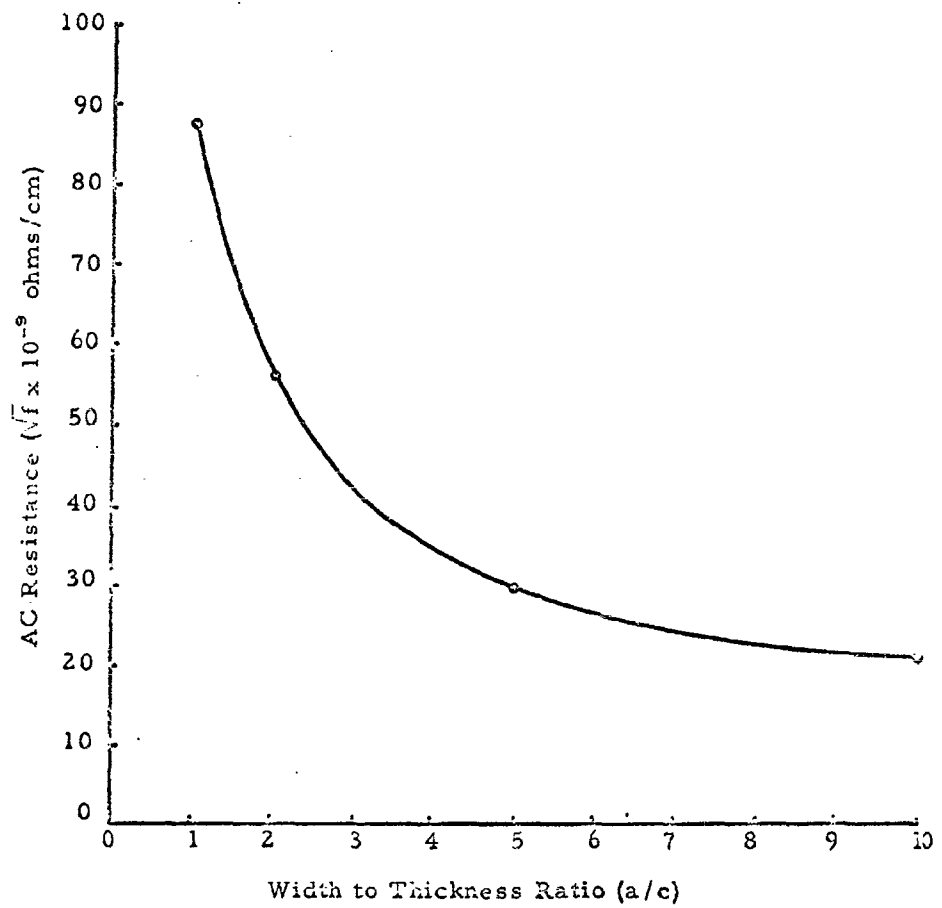

Figure 6- Plot of AC Resistance vs. Width to Thickness Ratio of Rectangular Bar.

TABLE II

OPTIMUM PHYSICAL DIMENSIONS OF RECTANGULAR BOND STRAP RELATIVE TO MINIMUM SELF-INDUCTANCE AND AC RESISTANCE.

	1/a	a/c	Example
Good	5/1	2/1	l = 10 a = 2 c = 1
Better	3/1	5/1	l = 10 a = 3.33 c = .666
Best	1/1	10/1	l = 10 a = 10 c = 1

The above table was obtained from Figures 5 and 6. No consideration was given to mechanical feasibility of implementation.

l = length

a = width

c = thickness

The following recommendations are presented considering Figures 5 & 6 and mechanical feasibility of implementation:

1. The length-to-width ratio (l/a) of a bond strap should be $\leq 5/1$, preferably $\leq 3/1$ when mechanically feasible.
2. The width-to-thickness ratio (a/c) of a bond strap should be $\geq 5/1$, preferably $\geq 10/1$, when mechanically feasible.

of the harmonic radiated will be a function of the source power, efficiency of the rectifier or non-linear impedance, and the natural resonant frequency of the external system.

All of the elements required to produce a harmonic-generating system are present in the complex tower structures and other objects that are found in intense RF fields. An RF signal produces standing waves on this complex antenna and wherever a corroded joint or oxidized fastening is placed, rectification will occur to some extent. Harmonic generation can be the result with a portion of the structure now becoming the transmitting antenna.

Reported tests⁵ show a 1N34 crystal diode being used to demonstrate a reasonably efficient rectifying action at a corrosive joint. The measurements were made with a double conversion receiver and a calibrating signal generator. Although the frequency range of the transmitter was considerably below a radar range (27 MC) the results can be held as valid at virtually any frequency. In one particular instance with a transmitter power of 320 watts, the diode setup with a 17" antenna radiated 2nd and 3rd harmonics peaking at 2000 μ v to a receiver antenna 50 ft. away from the diode setup. Since a receiver in the radar band has a -107 dbm sensitivity based on 1 μ v across 50 Ω , then this culprit signal of 2000 μ v is quite significant under any circumstances.

In addition to rectification and radiation of harmonics from a single source, the probability of a mixing action of two signals and the radiation of both sum and difference frequencies can occur. Although the efficiency of the natural non-linear device is probably lower in this case, the extent of RFI damage would be controlled by the physical location of the supporting structure.

2.1.1.3.2 Corona.

With small air gap spacings, very little radio noise is produced by corona below the arc-over voltage, and the corona-incidence and arc-over voltages are very nearly the same. With wider air gap spacings, the corona-incidence voltage is considerably below that at arc-over.

With an insulator of nylon or hard rubber in the gap, the corona-incidence voltage is lowered by a factor of 2 to 4. At

⁵ M. Seybold QST-RCA Jan. 53.

voltages below arc-over, the corona-induced radio noise of 2 to 10 times as intense as that caused by corona with air insulation. Corona appears at a lower voltage with rubber insulation than with nylon.

The utilization of Dow Silicone Compound #4, for example, demonstrated a propensity to corona only slightly lower than air, and the breakdown voltage is almost identical to air. A possibility exists of using this compound in conjunction with the other insulators to exploit the advantages of each in case insulators are required.

Rounding of the corners and beveling of the edges increased the corona-incidence voltage and the arc-over voltage by approximately 50%.

2.1.1.4 Some Facets of Corrosion

Material deterioration in the form of corrosion is a complex process. Much of this deterioration process can be traced to poor mechanical design either through a poor choice of materials or inadequate mechanical integrity. Under the most ideal circumstances it remains a problem that requires constant attention. The effect of corrosion on electrical impedance is well-known in the electronics community and its relation to equipotential ground planes, lightning protection, and RFI and personnel hazards have been demonstrated throughout this contract. The following discussion will deal with a few major corrosion causes:

A. Galvanic Corrosion.

When a more noble metal is joined to a lesser metal by the same corroding medium, electro-chemical corrosion will occur (See Figure 7). This simple battery cell action produces a high corrosion rate on the less noble metal, while the noble metal remains unharmed. One of the attendant problems here involves the coating of the noble metal with its less noble counterpart, resulting not only in mechanical weakness, but electrically a high impedance joint is formed. In fact, a rectifier of sorts is formed creating all the problems relative to harmonic generation and the like.

Galvanic Cells.

Galvanic cells may be formed as shown in Table III which will predict the direction of galvanic action. Metals shown in the table are considered safe from galvanic action generation and may be classified as fairly safe for electrical contact with each other.

Table III
Galvanic Series of Metals

Corroded End (anodic or least noble)
Magnesium
Magnesium alloys
Zinc
Aluminum 1100
Cadmium
Aluminum 2017
Steel or iron
Cast Iron
Chromium iron (active)
Ni-Resist. Irons
18-8 Chromium-nickel-iron(active)
18-8-3 Cr-Ni-Mo-Fe (active)
Lead-tin solders
Lead
Tin
Nickel (active)
Inconel (active)
Hastelloy C (active)
Brasses
Copper
Bronzes
Copper Nickel Alloys
Monel
Silver solder
Nickel (passive)
Inconel (passive)
Chromium iron (passive)
Titanium
18-8 Chromium-nickel-iron (passive)
18-8-3 Cr-Ni-Mo-Fe (passive)
Hastelloy C (passive)
Silver
Graphite
Gold
Platinum
Protected End (cathodic, or more noble)

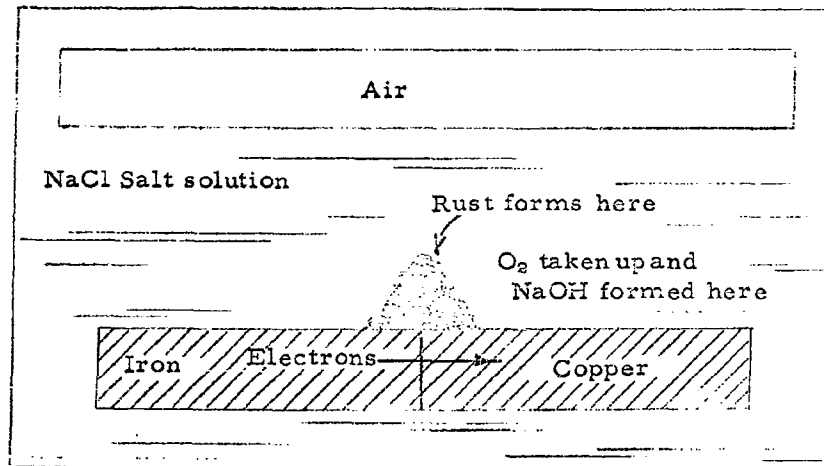

Figure 7. GALVANIC CORROSION.

Generally, metals very far apart on the list should not be used or galvanic action may attack the metal at the high end of the list. Metals from this list should be chosen as close together as possible; the further apart on the list the greater the corrosion tendency through the galvanic process.

To have galvanic action current, of course, must flow; in some cases the current uses the metals as a prime conductor, in others, such as structures in high RF fields, the metals will intercept power and become unexpected conductors. Therefore, corrosion through galvanic action requires a knowledgeable choice of construction materials and good periodic maintenance.

B. Corrosion Fatigue.

The dangers inherent to corrosion fatigue are those from breakdown of a protective film on the metals due to bending or vibration. Some metals have "self repair" characteristics and the corrosion process will be slowed, while others not having a "repair" characteristic will corrode rapidly. Figure 8 demonstrates a case of stress combined with corrosion. Suitable materials and stringent mechanical design will largely obviate this problem, but guarantees are difficult

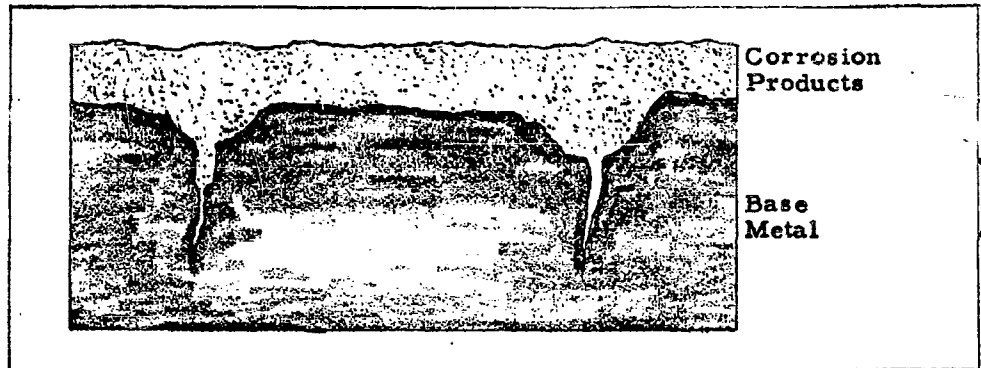

Figure 8. CORROSION FATIGUE.

to offer since little is known for any particular application solutions. Part of this problem reflects on the design engineers' unrealistic attitude of "no endurance limit" to the metal structure. There must be a limit set for replacement or heavy overhaul period.

C. Crevice Corrosion.

It is well-known that corrosion is likely to form in crevices due to a propensity towards retaining corrosive solutions (See Figure 9). Crevices can lead to differences in metal ion concentration at different locations, where, in a crevice area having a higher metal ion concentration than the surrounding edges, corrosion will take place at such edges. Obviously, elimination of this problem indicates smooth surfaces, filling of crevices and/or accomplishment of both through structure design.

D. Stress Corrosion.

Stress corrosion occurs when internally or externally stressed metals are exposed to a corrosive environment. Damage is in the form of localized cracks as shown in Figure 10. The loss of good bonds or structural integrity will be dependent on (1) the magnitude of stress, (2) corrosion medium present, (3) the structure of the base metal. Although stress corrosion is one of the most important and common types, it is virtually impossible to predict since the same

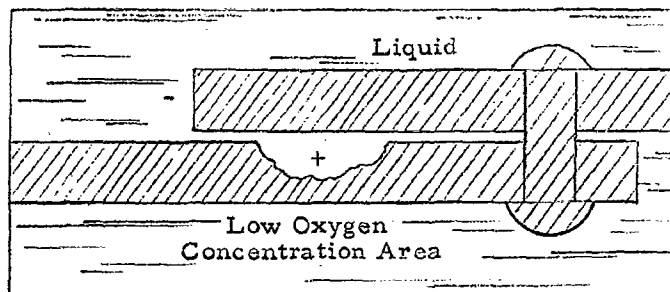

Oxygen Concentration Type

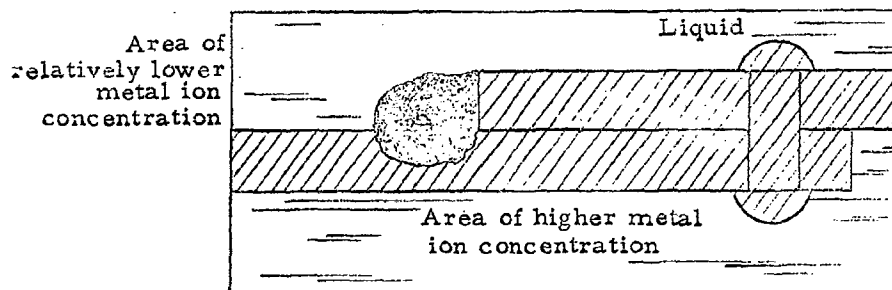

Metal Ion Concentration Cell Type

Figure 9: CREVICE CORROSION.

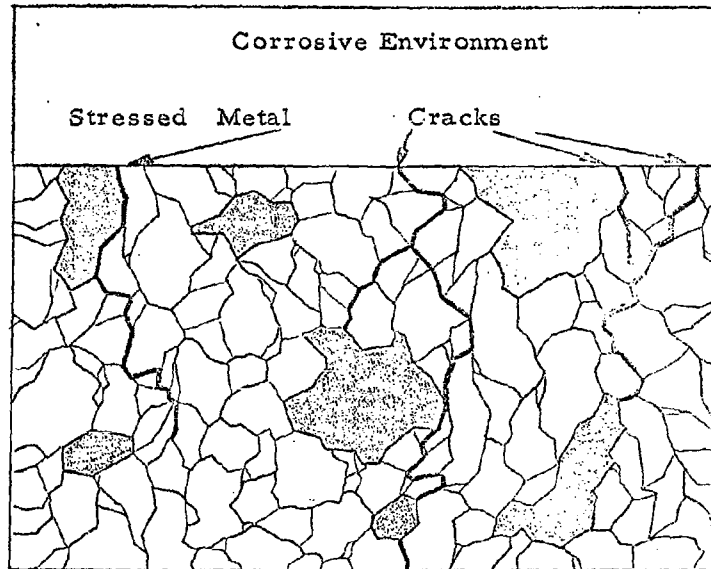

Figure 10. STRESS CORROSION.

conditions that cause cracking in one metal will not influence another in the same general category. In general, high strength aluminum alloys are susceptible to cracking and should be avoided if at all possible.

E. Design to Minimize Corrosion.

The following figures, Figure 11 through 13 demonstrate good design practice in structural assembly to reduce a propensity toward corrosion and the attendant electronic problems. Although these recommended construction procedures will not guarantee relief from corrosion problems, they represent a "best design" configuration.

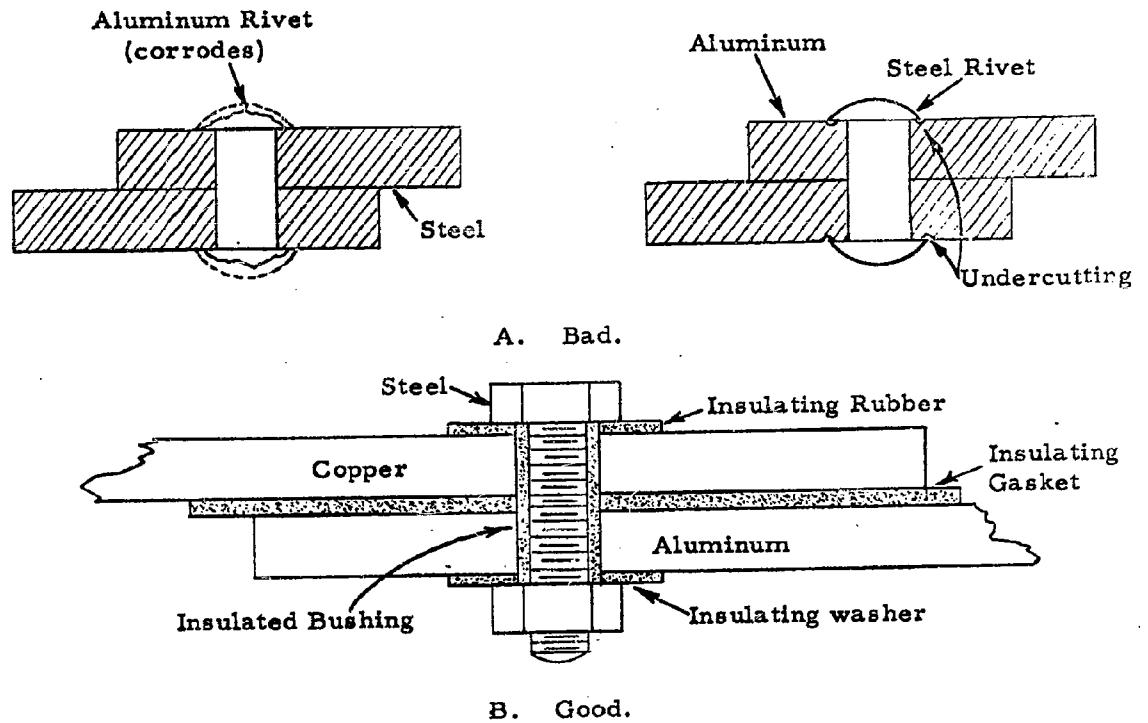
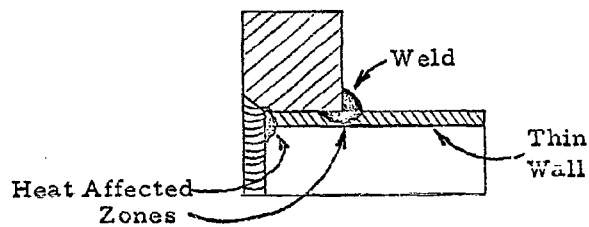
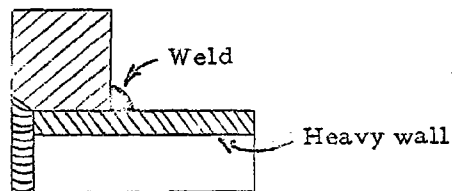

Figure 11. CONNECTION OF DISSIMILAR METALS.*

* Figure 11 shows two examples of galvanic corrosion. Corrosion of an aluminum rivet can be expected when it is used to fasten steel sheets together. Similarly if a steel rivet is used to fasten aluminum sheets, then undercutting galvanic corrosion of the aluminum sheet will result in loose rivets, slipping and possible structural damage. Corrosion of this type can be prevented by applying a nonhardening insulating joint compound in the area where the sheet and the rivet or bolt are in contact. Where the fasteners are not subject to high stresses the contact points can be insulated with plastics or other nonmetallic sleeves, shims, washers and similar parts.



A - Bad



B - Good

Figure 12. WELDING TO AVOID EXCESSIVE HEATING.*

* Corrosion can occur in aggressive solutions or areas where variations in grain size are produced by the heat from welding. Corrosion rates vary according to the heat input of the welding method and the geometry of the joint. Here the grain structure is changed by high temperatures caused by the inability of heat to dissipate. The possibility of corrosion in these areas can be avoided by making the wall heavier so that the heat is dissipated more rapidly, as shown in B.

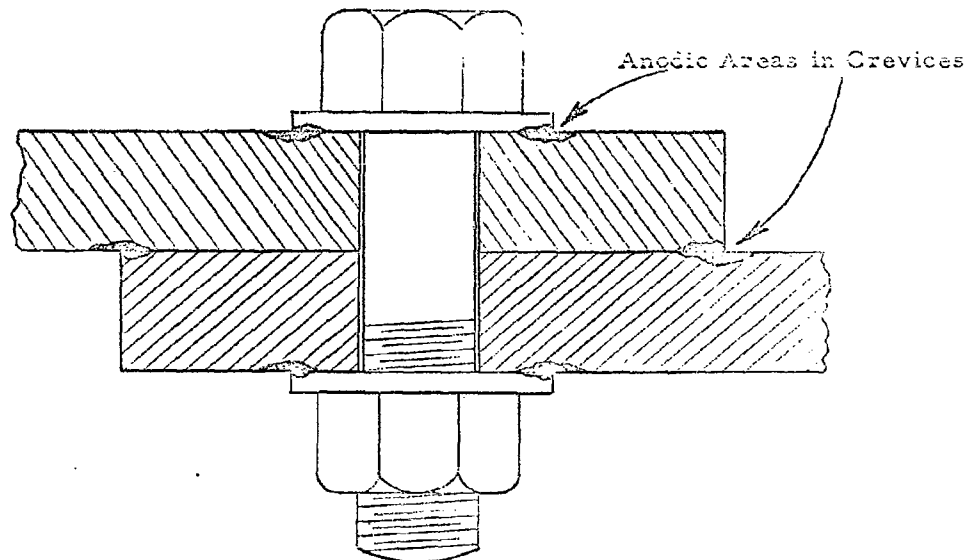

A - Bad

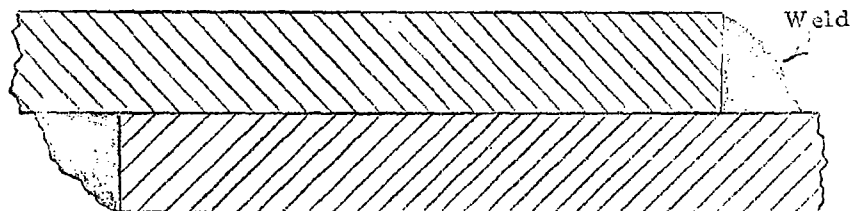

B - Good

Figure 13. CORROSION PREVENTION BY USAGE OF WELDING.*

* Crevices are a potential source of concentration cell corrosion. They are frequently encountered in sections such as shown in sketch A where two plates are bolted together in a corrosive solution. No matter how much torque is applied to the bolt it is practically impossible to eliminate crevices into which the solution gradually penetrates and becomes stagnant. Crevices can be avoided by using welds (B) instead of mechanical fasteners, or by using fluorocarbon gaskets between surfaces that are machined parallel.

F. Coatings to Prevent Corrosion⁵

Following is a summary of the most important types of metallic coatings you can use. These coatings can be applied by electrodeposition, flame spraying, hot dipping, cladding and other techniques.

Zinc and Cadmium coatings both are less noble than steel under most conditions. Thus, they can be used to cathodically or galvanically protect iron and steel.

Nickel Coatings unlike cadmium and zinc, are more noble than iron and steel and do not provide sacrificial protection. To protect the base metal they must provide an impervious, nonporous barrier. Electroplated coatings can be used in thicknesses up to 80 mils and, for added adhesion, they are usually applied over a very thin layer of copper.

Chromium electroplates are especially useful where tarnish resistance combined with hardness, wear resistance and/or a low coefficient of friction is needed. They are most frequently used to preserve the appearance of nickel electroplates.

Silver Electroplates can be useful in many corrosive applications. They are immune to attack by most dry and moist atmospheres and, although attacked by ozone, they resist the effects of oxygen at high temperature.

Other Metal coatings such as aluminum, tin, lead, monel, stainless steel, and various hard facings are frequently used to protect iron and steel against corrosion. Hot dipped aluminum coatings are especially useful where a combination of heat and corrosion is encountered and they have high resistance to corrosive condensates which form when a heated part cools down. Tin, of course, is widely known for its use on corrosion resistant food containers. Lead coatings are noted for their ability to form a film of environmental reaction products, such as lead sulfate, which are highly resistant to corrosion.

Nonmetallic Coatings:

High corrosion resistance can also be provided by organic coatings, rust preventives, ceramic and glass linings, and by porcelain enamels which are highly resistant to water, acids and chemicals.

⁵ by L.H. Seabright, Electrochemical Research Laboratory, Amphenol-Borg Electronics Corp., and Robert J. Fabian, Associate Editor, *Materials in Design Engineering*, January 1963.

Chemical conversion coatings may also be used alone or under an organic coating. Zinc, manganese and iron phosphate coatings, for example, are commonly used to retard corrosion and serve as a good base for organic coatings. The tendency of zinc to form white corrosion products can be prevented by using a chromate conversion coatings which, in the presence of water, hydrolyzes to form inhibitive ions. Special chemical and electrochemical treatments such as anodizing are also available for protecting aluminum and magnesium against corrosion.

Many specialized organic coatings have also been developed to resist atmospheric corrosion and direct chemical attack. Following is a summary of the major corrosion resistant coatings and their important properties:

Bituminous coatings have high resistance to water, outdoor atmospheres and underground exposure.

Cellulosic coatings, such as cellulose acetate butyrate and heavy coatings applied by the fluidized bed, are noted for outstanding resistance to weathering.

Epoxy coatings have excellent resistance to many chemicals. Several classes of materials are available of which the epoxy-phenolics have the best chemical and solvent resistance. The recently developed 100% solids epoxy coatings, which can be applied in heavy thicknesses, are also noted for their resistance to water and chemicals.

Fluorocarbon coatings probably have higher chemical resistance than any other organic coatings and most metallic coatings. Several types are available.

Phenolic coatings have excellent resistance to chemicals, solvents, oil and water.

Polyamide coatings, especially thermosetting blends, have high resistance to chemicals and solvents. Polyamide-phenolic coatings are noted for their excellent resistance to the passage of water.

Polyester coatings, especially 100% solids coatings, have excellent outdoor durability, good resistance to water and salt spray, and high resistance to many chemicals.

Polyethylene coatings and linings have very low water absorption, and excellent resistance to some chemicals, especially strong oxidizing acids.

Silicone coatings have excellent resistance to moisture, salt spray and acids, particularly at high temperatures.

Styrene-butadiene primers have excellent rust-inhibiting and chemical resistance properties.

Urethane coatings are especially noted for their resistance to water and outdoor weathering, and can be formulated with a high degree of chemical resistance.

2.1.2 Specific Bonding Recommendations Relative to (1) Reduction in Impedance, (2) Reduction of Harmonic Generation and Corona and (3) Corrosion Resistance.

The following are a list of applicable bonding recommendations that were obtained from specifications, existing literature, and engineering judgment based upon practical experience.

1. Permanent joints of metallic parts made by welding, brazing, sweating, or swaging; semi-permanent joints of machined metallic surfaces held together by lock-threaded devices, rivets, tie rods, structural wires under heavy tension, pinned fittings driven tight and not subjected to wear, and clamped fittings normally permanent and immovable are considered as meeting the inherently bonding requirements.

2. In all cases where possible and practical, mating surfaces of metallic member should be welded around the entire periphery of the contacting area.

3. In lieu of welded or brazed connections, bolted sections may be used. Bolted sections must be implemented to insure (1) a consistent contact pressure over an extended period of time, (2) minimal crevice areas around metallic mating surfaces, and (3) a resistance to atmospheric corrosion over an extended period of time. It is recommended that palnuts be used to permanently tighten joints as indicated in Figure 14.

4. Rivets should not be used on metallic sections subjected to fluctuations in stress or strain or minute movements of the bonded connections. Rivets are considered a fairly good electrical connection under static conditions, however, they become permanently deformed under fluctuating loads which results in either a poor or no electrical connection at all. When rivets are used to bond static metallic members, the requirement stipulated for a bolted joint should be adhered to.

5. If rivets are used for connecting metallic members, and if such connections are to be considered as electrical connections, a bond strap should be implemented across the riveted connections as shown in Figure 15.

6. Bond straps should be implemented across all expansion joints which are required to meet electrical connection requirements using techniques as indicated in Figure 15 for rivet joints.

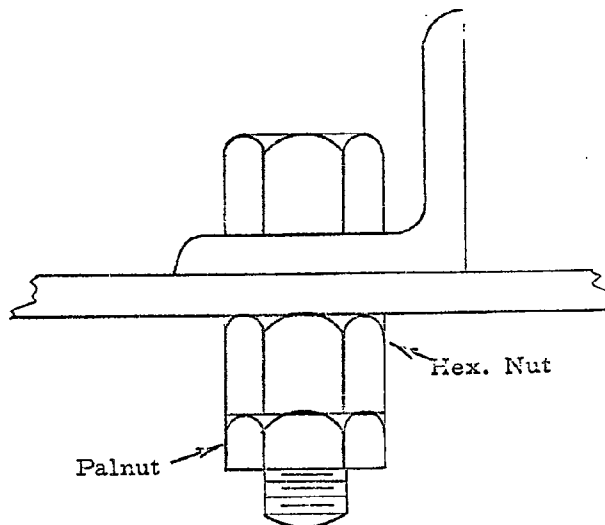

Figure 14. . . USAGE OF HEXAGONAL AND PALNUTS.

7. All protective coatings must be removed from the contact areas of the two mating surfaces before the bond connection is made.

8. The nonreplaceable portion of a bonded joint that must be formed by dissimilar metals should be a metal lower in the series than its mate.

9. When the junction of two dissimilar metals cannot be avoided, select metals close to one another in the electromotive force series.

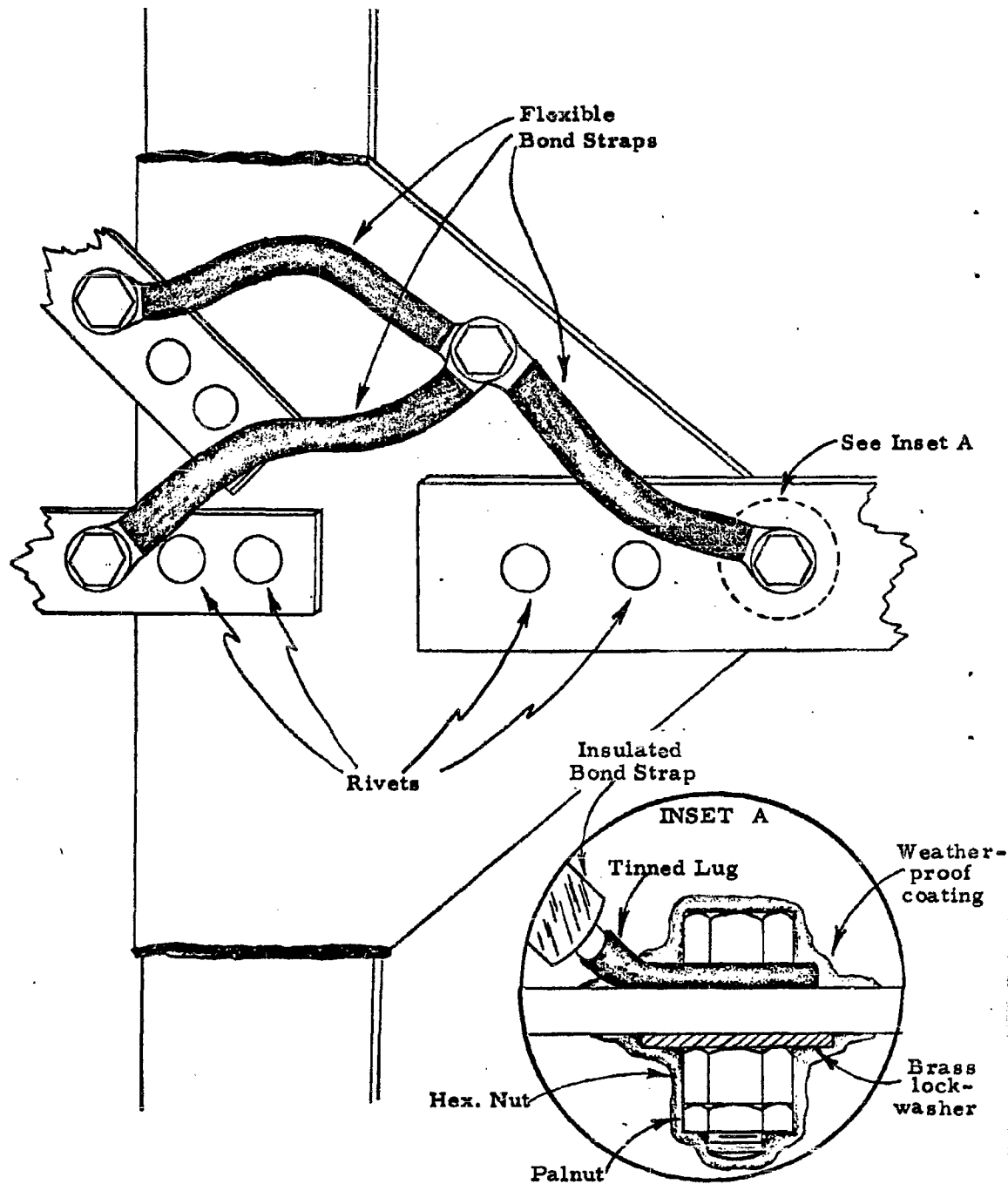

Figure 15.7. TECHNIQUES FOR BONDING METALLIC MEMBERS CONNECTED BY RIVETS.

10. When pressure bonds are made, the surfaces must be dry before mating and held together under high pressure to minimize the chance of moisture creeping into the joint. The periphery of the exposed joint should be sealed with a suitable protective compound.

11. For direct or low-frequency alternating currents, bonding may be accomplished by either a wire or a length of tinned-copper braid.

12. Solid bonding straps are recommended in lieu of braided straps due to the lower self-inductance of the solid strap.

13. Flat, braid bonding straps may be used in applications where frequency is below 30 megacycles. Measurements indicate that the impedance of a braided strap is similar to a solid strap at frequencies up to 30 megacycles.

14. To provide adequate bonding for lightning protection, bonding jumpers of tinned-copper stranded cable should have a minimal cross-sectional area of 6475 circular mils to withstand a maximum current surge of 100,000 amperes and a rise time of 10 microseconds and damped to one-half its maximum value in 20 microseconds. If stranded aluminum cable is used, the minimum cross-sectional area should be 10,000 circular mils.

15. Due to the oscillatory nature of the lightning discharge, stranded wire must be used to minimize the skin effect.

The following recommendations are applicable for bonding jumpers:

1. The length-to-width ratio of a bond strap should be ≤ 5 to 1, preferably ≤ 3 to 1 when mechanically feasible.

2. The width-to-thickness ratio of a bond strap should be ≥ 5 to 1, preferably ≥ 10 to 1 when mechanically feasible.

3. The bonding strap should be solid metal.

4. The strap should be bonded directly to the basic structure rather than through any adjacent part.

5. The strap should be installed so as to be unaffected by motion or vibration.

6. The strap shall be installed in an area that is accessible for maintenance and installation.

7. The straps shall be mounted in an area where they can be afforded maximum weather protection.

8. The strap shall be kept as short as feasible.

9. Single straps shall be used; two or more straps shall not be connected in series.

10. Straps shall be mounted so that they will not restrict the movement of the structure members.

11. Straps shall be mounted so that they will not weaken the structure to which attached.

12. Straps may be shaped to accommodate optimum installation.

13. Straps shall not be compression-fastened through plywood or other nonmetallic material.

14. When the bond strap width (W) is equal to or less than 1.5 inches, the bolt hole diameter will be not greater than $W/3$ and centered on the end of the strap.

15. When the bond strap width is greater than 1.5 inches, but less than 3 inches, two bolts will be used and centered at $W/4$ from the strap sides and end.

16. When the bond strap width is greater than 3 inches, but less than 6 inches, a bolt will be used at intervals of 1.5 inches or less.

17. When the length-to-width ratio of 1:5 requires a bond strap width in excess of 6 inches, multiple bond straps can be used. In no application will the distance between bond straps exceed 30 inches. The bond strap connections detailed above, will be followed for multiple strap installations.

18. Any installation requiring a deviation from the above procedures, will be considered special cases and left to the discretion of the user. In all installations, the ideas above should be paralleled and good engineering procedures should prevail.

19. A single tooth-type lock washer is the preferred method for connecting a bond strap to a metallic object. The double tooth-type lock washer is an alternate method for bonding. Figure 16 illustrates connections that will be made with the single and double tooth-type lock washers.

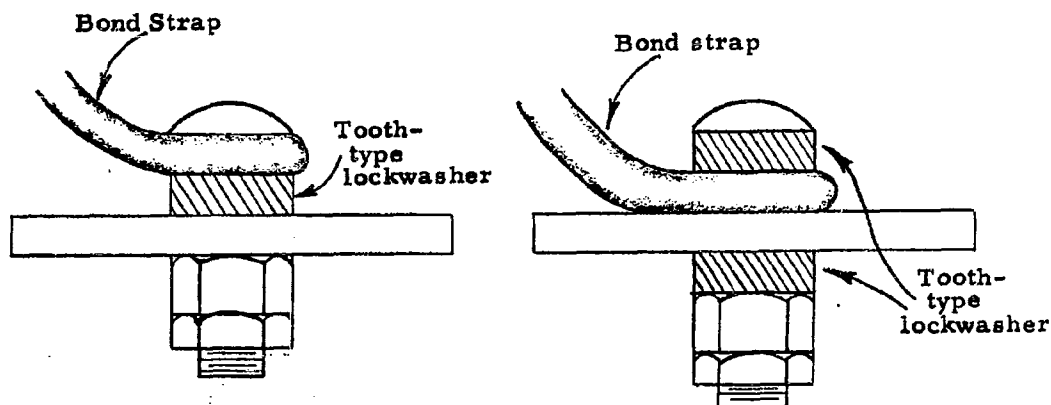

Figure 16. PREFERRED LOCK WASHERS USAGE.

Acceptable methods of making connections between bonding jumpers and structures of various metals are indicated in Table IV. The metals are listed in order of decreasing activity in salt water, and the higher metal in the series will be the one attacked in case of galvanic action between any two. In general, the greater the separation between any two of the metals, the more pronounced the corrosive activity will be. The screws and nuts to be used in making the connections are indicated as Type I, cadmium or zinc-plated, or aluminum, and Type II stainless steel. Where either type screw is indicated as acceptable, the Type II is preferred from a corrosion standpoint.

The following recommendations are made relative to preferred construction techniques to counteract corrosion.

1. In cases where dissimilar metals are to be connected, insulating materials should be inserted between mating surfaces. Such a connection will not be an electrical connection but rather a method of providing a semi-rigid joint between two media.

Table IV
Metal Connections

Metal Structure (outer finish metal)	Connection for aluminum jumper		Connection for tinned copper jumper	
Magnesium and Mg base alloys	Direct or Mg washer	Type I Screw	Al or Mg Washer	Type I Screw
Zinc, cadmium, aluminum and Al alloys	Direct	Type I Screw	Aluminum Washer	Type I Screw
Steel (except stainless steel)	Direct	Type I Screw	Direct	Type I Screw
Tin, lead, and Pb-Sn solders	Direct	Type I Screw	Direct	Type I or II Screw
Copper & Cu base alloys	Tinned or cadmium-plated washer	Type I or II screw	Direct	Type I or II screw
Nickel and Ni base alloys	Tinned or cadmium-pltd. washer	Type I or II screw	Direct	Type I or II screw
Stainless steel	Tinned or cadmium-pltd. washer	Type I or II screw	Direct	Type I or II screw
Silver, gold, and precious metals	Tinned or cadmium-pltd. washer	Type I or II screw	Direct	Type I or II screw

2. Use rivets, bolts and other bonding media which are made of metals which are galvanically compatible with mating materials.
3. Prevent surface damage or marking of metallic surfaces.
4. Avoid excessive welding heat.
5. Eliminate crevices at bond connections as much as possible.

6. Coat all metallic members and bonded joints with protective coatings to prevent corrosion.

The following recommendations are made relative to preferred technique to preclude the effects of corona and harmonic generation:

1. Flexible shunt in the case of moving joint (See Figure 17(a))
2. Quality welded bead where possible around joint even if bolted or riveted initially (Figure 17(b)).
3. Removal of excessive edge roughness and rounding of sharp protuberances whenever possible.
4. Allow no air gap spacing to exist if possible.
5. If air gap is necessary use widest gap practical.
6. Employ insulator in any gap where possible (Figures 17(c)&(d))
7. Shunt gap with best possible bonds where practical.
8. Paint or otherwise treat all exposed surfaces when and where possible.

2.1.2.1 As Applicable to Structure Usage.

Previous bonding recommendations should be implemented on buildings or structures when electromagnetic interference imposes a potential hazard. Obviously all of the recommendations are not applicable to all situations; i. e., a water tower structure far removed from any high power radiating source and having metallic members connected by riveted joints, need not have bond straps placed across riveted joints; the same water tower may require bond straps across riveted joints if situated near a high power radiating source. As a result of such environmental parameters, blanket recommendations cannot be practically made relative to implementation of preferred bonding techniques on specific structure type. The following recommendations are made for various structures to exist in various environments:

1. Structures in the near vicinity of high power transmitting antennas (antenna towers, towers, missile test and launch complexes, communication centers, radar centers, ordnance storage buildings) should comply with all bonding recommendations stipulated in Section 2.1.2.

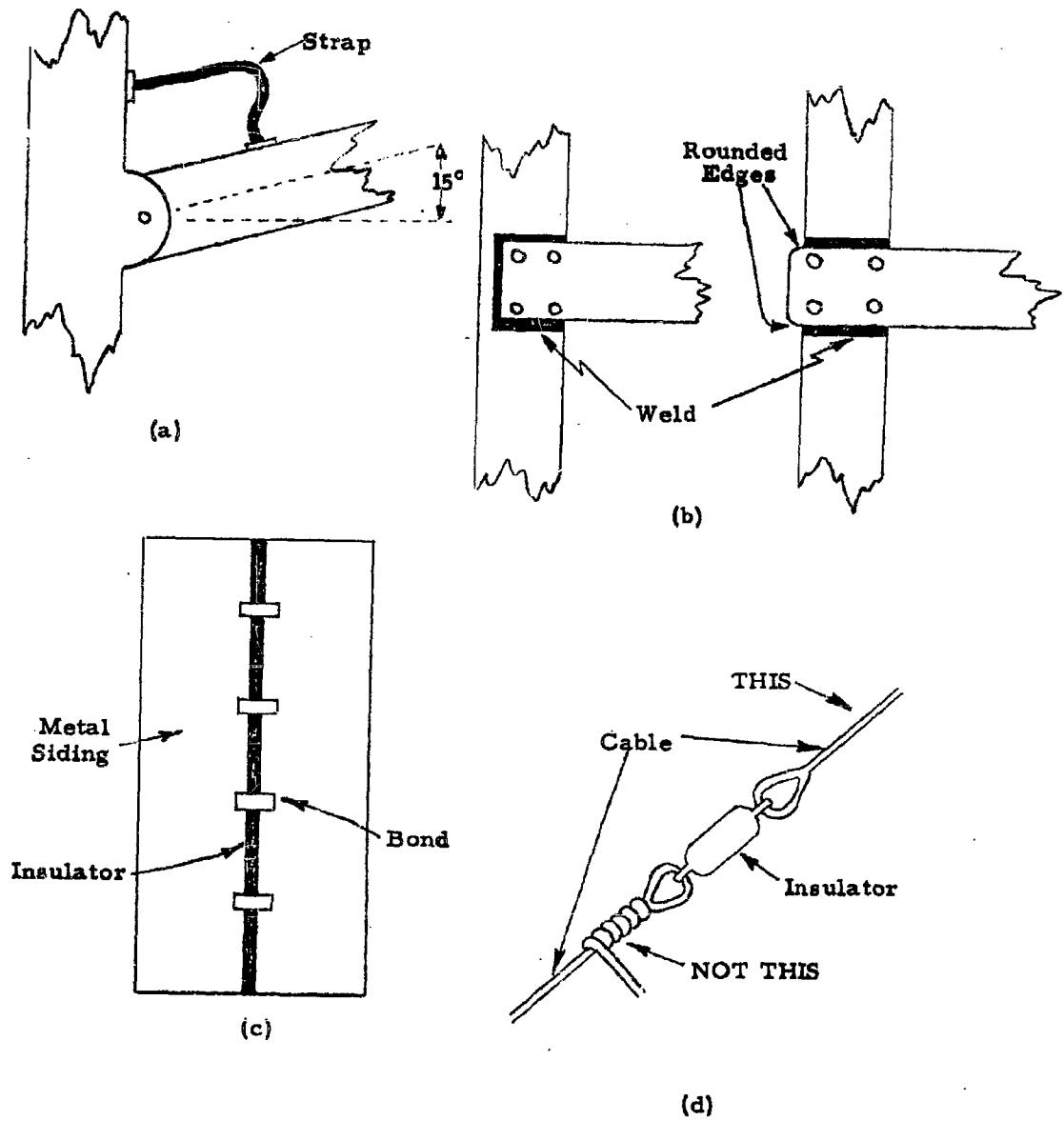

Figure 17. TECHNIQUES FOR MINIMIZING HARMONIC GENERATION AND CORONA.

2. Structures housing electronic equipments which are susceptible to or capable of generating electromagnetic energy (antenna towers, missile test and launch facilities, communications centers, radar centers, ordnance storage buildings) should comply with all bonding recommendations stipulated in Section 2.1.2.

3. Structures subject to large amount of current flow as a result of power system fault currents or other sources, which are located in the near vicinity of other structures housing equipments susceptible to electromagnetic energy, should have all metallic members bonded as stipulated in Section 2.1.2.

4. Structures subject to large amounts of current flow, which are not located in the near vicinity of other structures housing equipments susceptible to electromagnetic energy, but which are connected to such structures by means of hardwire, should have all metallic members bonded as stipulated in Section 2.1.2.

5. Structures not included in any of the previous categories do not impose a potential electromagnetic interference threat and therefore need not comply with stipulated interference specifications. However, it must be realized that environmental conditions may change with time which could at a later date place a structure in one of the previous categories and impose corresponding bonding requirements on the existing structure. Responsible personnel must consider such possibilities and the resultant cost that would be incurred by incorporating such bonding techniques on an existing structure. Where the possibility of such environmental changes exist, personnel may be well advised to consider implementing bonding techniques stipulated in Section 2.1.2 during construction procedures from an economic point of view.

2.2 Interference and Hazards of Lightning Discharges.

This section discusses RFI and hazard protection considerations for buildings and antenna foundation structures. The hazardous effect on personnel and property damage needs no justification in this text, but the RFI implication of a heavy lightning stroke may not be as well understood.

Ground systems that serve military equipment sites are vulnerable to damage if proper procedures cited in this section are not carried out. To illustrate: if a ground wire in a structure is mechanically damaged and then suffers the short time, but high current from a lightning stroke, the damaged area can become a high impedance fault. The fault will allow circulating ground currents and a radiation condition within a normally "quiet" equipment area.

The loss of grounds on tower structure can result in the abandoned structural element acting as a radiator at any frequency where it appears as a multiple of $\lambda/4$ wavelengths.

A structure may suffer mechanical injury to one or more joints due to stresses created by the very high surge currents; this can result in areas being opened to weather and the subsequent oxidation of the metal surfaces which in turn creates a harmonic generator since this situation represents a non-linear external system.

Therefore, care should be taken to observe all possible methods of preventing significant lightning stroke damage.

2.2.1 Antenna Structures and Support structures.

The presence of an antenna on the roof of a building will not be expected to increase significantly the buildings propensity to lightning strokes. However, in the event the building is hit, the antenna will almost always be the focal point of the stroke. Where the antenna support is attached to a metal frame building, the support, if metal, should be bonded to the building frame with No. 2 Copper Wire. All guy wires from the antenna support should also be bonded to the building frame. No. 6 AWG will be sufficient in this case.

In cases where the building frame is of material other than metal the most significant point will be to conduct the stroke currents to ground without arcing to other objects along the current path. Where there is less than 6 feet separation between a grounded antenna support or grounding conductor and lightning protection wires or other grounded structures, e.g., pipes, conduits, etc., a No. 6 AWG Copper Wire bond should be employed to prevent arcing. Objects of less mass such as gutter-spouts, ventilators, down-spouts, etc., should be bonded at the most upper end to ground wire or grounded antenna support structure. Should they be of extreme length then the bottoms should also be grounded to the ground structure at the farthest point also. Grounding these structures will prevent side flashes that will likely occur when separation is less than 6 feet.

Side flashes can cause considerable damage or set fire to a building. Adequate separation is preferable to bonding because of the difficulty often encountered in making satisfactory connections.

If the antenna support is constructed adjacent to buildings, the grounding system shown in Figure 18 will prove satisfactory under normal conditions.

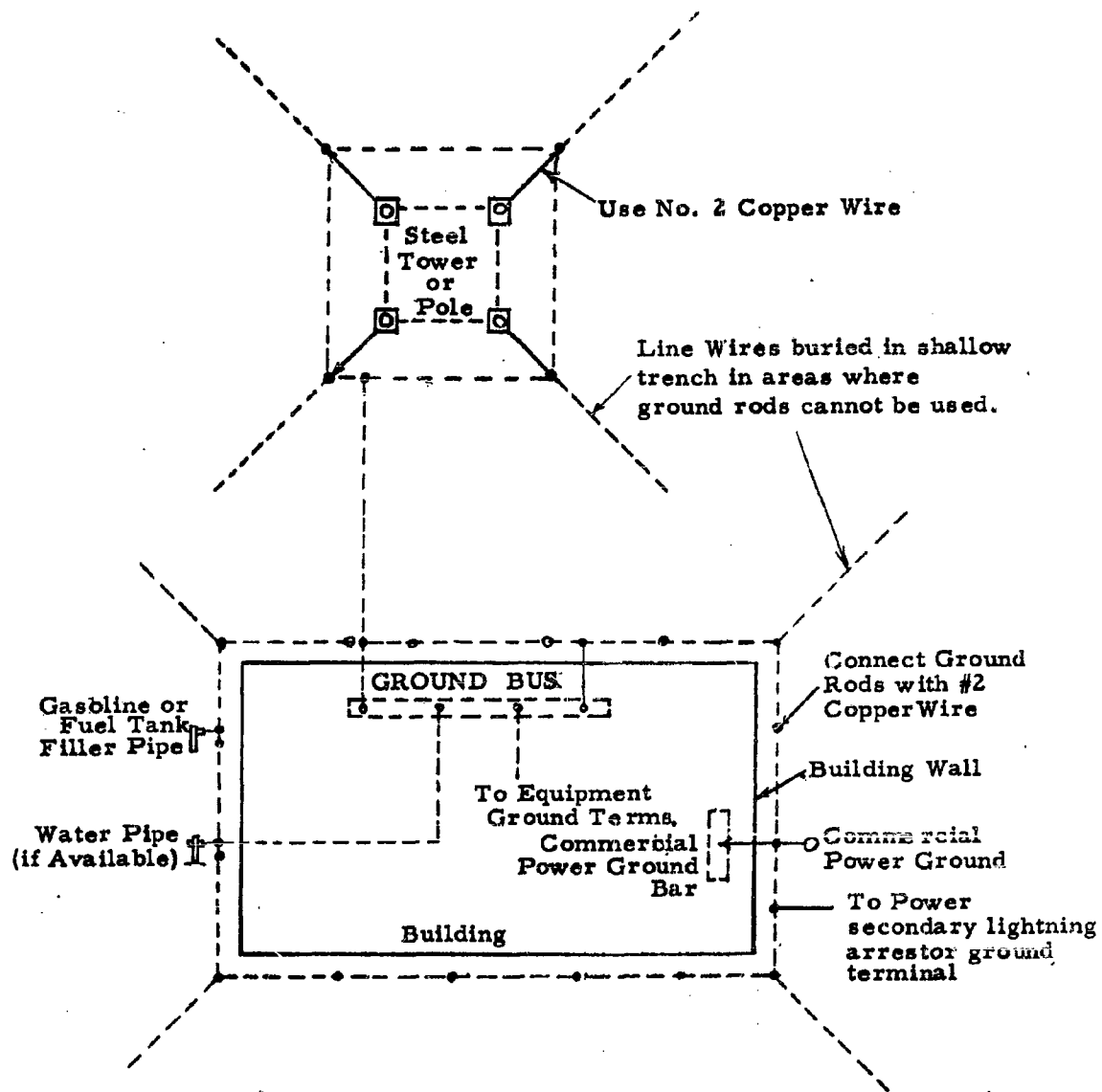

Figure 18. GROUNDING ARRANGEMENT - FIXED BUILDING AND ANTENNA FOUNDATION.

2.2.1.1 Guyed Structures

Guy anchors will provide additional grounding when soil conditions are good; however, in high resistivity soil or when the guy wires are anchored in concrete one or more rods should be driven as close as possible to the concrete anchor and connected to equalize earth potential as much as possible in case of damage to the concrete block due to a heavy stroke. The rods should be bonded together and to the guy wire with a No. 2 AWG Copper Wire. In areas where ground resistivity is extremely high, consideration should be given to grounding to the building ground.

2.2.1.2 Self-Supporting Towers.

Towers that are embedded in concrete bases should have a ground rod driven at the base of each tower footing and bonded to the tower leg by No. 2 AWG Copper Wire. The ground rods should be located as close as possible to the tower footing, tied together, and tied to the station ground.

2.2.2 Recommendations to Preclude Interference and Hazardous Aspects of Lightning Discharges.

Structures in Areas Prone to Lightning.

This section discussed lightning protection considerations for fixed antennas and buildings, The problem areas to be considered are:

- a. Antenna and Support structures.
- b. Building and equipment housing.
- c. Transmission lines.
- d. Site Equipment.

Sites in sparsely settled areas may be exposed to direct lightning strokes to the antenna, structure, connecting power and/or transmission lines. Often the facility connections and the facility structure ground system is less efficient than grounds in urban areas. In urban areas nearby buildings may divert strokes of lightning from antenna or buildings of less size and height. The added presence of water mains, gas pipes, and other well-grounded metallic structures to serve as facility grounds enhance lightning protection. These grounds prove superior to grounds in remote areas where soil conductivity is very poor or will not otherwise allow an excellent ground system to be installed.

The main lightning protection considerations at these sites are:

- a. Protection of personnel
- b. Protection of equipment
- c. Protection of structure.

Common grounding of all metal portions within the structure and proper bonding of equipment to the structure ground plane will provide the best personnel protection and in addition provide the best possible equipment and building protection by eliminating the possibilities of potential differences that might result in arcing damage. Steel reinforcing rods poured in concrete walls and roof slabs or steel roof supports or trusses should be tied together and grounded (cf., Section). Buildings which have metallic outer coverings should be grounded to the site primary ground.

The grounding scheme will vary depending upon the building or structure type, antenna structure, and physical location of the station. Where available low resistance water pipe grounds may be used or a well-grounded multiground neutral power system. In other cases the ground network established around the structure and/or antenna support will be the main grounding point. While a low resistance ground is desirable from a lightning stroke current standpoint, it is of greater importance that all grounded parts of the site are bonded together and grounded in a configuration to obtain the shortest possible paths to ground and if practical to obtain multiple paths to the site ground system.

Building Protection Considerations.

A grounding plan for a typical fixed installation and the antenna support structure is shown in Figure 18 . All ground connections to the main grounding point are made outside the building; this allows lightning currents to go directly to ground without entering the building. Where ground wires cross they must be securely bonded to prevent arcing. (The method of joining bonds may be seen in Section 2.1.2). Careful planning must be used to avoid ground conductors close to other grounded structures, e.g., structural ironwork, water, gas or steam pipes or electric power conduits that may be concealed in the building walls or partitions. Arcing to such structures from lightning strokes is commonplace and will result in material damage as well as an RFI threat due to form change in ground conductor material. If precautions are taken beforehand to insure at least a 6 ft. separation, the need for bonds will be reduced and a satisfactory ground system will be the result at much less expense and effort. Another important point in establishing grounding conductor layouts is to avoid "U" shaped wire runs. In many instances such shapes precipitate arcing and spark over. Every effort should be made to preserve a downward or at least a horizontal course for ground conductors to stay near the ground plane.

Data have indicated that a No. 10 AWG Copper Wire provides adequate conductivity for practically any lightning stroke current up to approximately 250,000 amperes - mainly because of very short current flow duration. A wire of larger size may be desirable for mechanical reasons only. In general, No. 10 AWG will meet both electrical and mechanical requirements. At any time that the ground wire is not subject to mechanical injury it should be attached directly to the structure rather than run through a protective conduit. This eliminates the "choking" effect when the ground wires are run through conduit due to increased impedance during heavy current flow. This effect is eliminated by periodically bonding the ground wire to the conduit and still maintaining mechanical protection.

Where stations are built in locations that are known to be exposed to severe lightning such as mountain tops, rocky hills, etc., or the soil will not permit the driving of ground rods, then a network of wires No. 10 AWG placed in shallow trenches radiating from the corners of the building or antenna structure should be employed. The trenches should allow for a bare minimum of a straight 12-foot run of wire. The terrain will determine the length, but runs up to 500 feet may be reasonable as insurance against lightning damage. Low resistance of such grounds is desirable but not essential since the distribution of metal in the earth is of primary importance in the dissipation of lightning current without damage.

2.3 Surface Treatment to Preclude Interference Effects

The presence of heavy nicks, cuts or very bad abrasions of metal surfaces and edges can result in an RFI threat. The previous study program AF30(602)-2691 experiments indicate a strong propensity toward corrosion if the structural element has: (1) $\lambda/4$ or multiple at the source or resonant frequency of the intense field, (2) breakdown will occur at very rough edges, such as rough sand cuts, and (3) at deep nicks or extremely sharp edges. The resulting dielectric breakdown will produce radio noise gaussian in distribution and centered about the source frequency.

In addition, nicks and rough edges contribute to corrosion which in turn can result in oxides being produced to enhance the cause of harmonic generation (cf. Section 2.1.1.4). Properly applied anti-corrosion paints will contribute significantly in reducing this hazard to an RFI-free environment.

2.3.1 Paint Life Expectancy

Paint can be expected to have a life of about four or five years under average conditions. Painting of the inner faces of the tower need not be undertaken until the galvanizing is near the end of its life. The life of galvanizing is, of course, largely a function of the concentration of corrosive elements in the atmosphere and the thickness of the zinc. In dry rural areas, for example, two-ounce galvanizing may last 20 to 30 years. In river valleys where heavy concentrations of coal smoke may be encountered, galvanizing has disappeared in less than 10 years. Some towers, of course, are not galvanized and here the paint film must be relied upon to protect the metal.

Towers in seacoast locations may show deterioration of paint in two or three years, however, because of the effects of wind-driven sand and the added intensity of reflected sunlight plus the usual direct rays of the sun. Although paint may still be adhering to the surface, it may be "dead" even though it looks "good". If the paint retains any life, a knife blade drawn across the surface at an angle will produce a "curl" much like the shaving made by a plane. If the paint is brittle and crumbles as it leaves the knife blade, it is dead and the structure should be repainted. This criterion should be applied particularly when the paint film is primarily for protection against corrosion. This test should be made on the face or faces of the tower most exposed to the sun (usually the southern exposure).

There is no paint known which will adhere to surface covered with loose dirt, grime, rust, bird droppings, grease, loose scale, etc. The surface to be painted must be thoroughly cleaned before painting or early peeling will result. It is not generally practical to use pneumatic or electrical tools for cleaning tower surfaces and it is usual practice to employ manual cleaning methods using hand tools.

The equipment required for preparing a tower for painting includes coarse sandpaper, scrapers and light chipping hammers. Wire brushes with fine, soft bristles tend to polish the surface, while coarse wire bristles have a fairly effective cleaning action. Coarse sandpaper or emery cloth is also effective. Lightweight hammers are not only less tiresome to use, but also reduce the possibility of bending lightweight structural members.

There may be some question as to whether "spot" priming or full coat priming is the proper job. Full-coat priming provides a somewhat better job, but generally costs somewhat more unless the area of the spots runs to more than about one-fifth of the total area to be painted.

Zinc dust oxide paint (such as that marketed under the trade name "Zox") is recommended as an undercoat particularly for use on galvanized steel. Unless zinc has been phosphate-treated or weathered for quite a while, adhesion can be quite a problem. A chemical reaction between zinc and certain elements in paint results in formation of a soapy film. Powdered zinc in paint permits this reaction to take place throughout the paint film rather than concentrating it at the surface of the galvanizing. Also there is some protective action of the zinc in protecting the steel - somewhat akin to the protective action of galvanizing. If zinc dust oxide paint is used, it should conform to Federal Specification TT-P-641 Type I.

Where rusted steel is encountered, the rust should be chipped or scaled off and the surface cleansed with a wire brush, boiled linseed oil should then be applied, followed by a coat of rust inhibitive primer such as zinc chromate. (Boiled linseed oil dries somewhat more rapidly than non-boiled). Field boiling of raw linseed oil is not recommended as it tends to decompose the oil unless the operation is performed in an inert atmosphere. This is, of course, highly impracticable outside of a specially-equipped plant. Linseed oil has the effect of sealing out moisture and this method of protection has been used successfully by the Navy.

2.3.2 Treatment of Irregularities.

Surface treatment of structural materials in high RF fields will contribute to corona occurrence if precautions are not followed to avoid unnecessary rough treatment. Design criteria should indicate less than square corners whenever possible and as little surface indentation or nicking as possible.

The rounding of corners and edges increases the corona-incidence voltage and the subsequent arc-over voltage by approximately 50%. Sharp corners or rough spots can provide voltage gradient of sufficient magnitude to initiate a "brush" discharge or corona. Even a slight rounding of sharp edges can be extremely beneficial.

2.4 Complimentary Construction Techniques Relative to the Attenuation of Electromagnetic Energy.

Structures housing electronic equipments susceptible to or capable of generating electromagnetic energy, generally incorporate shielding techniques during construction procedures for the purpose of attenuating radiated electromagnetic fields. Such techniques are in the form of

(1) conductive mesh in walls and ceilings, (2) installation of doors and windows which have proven effective in attenuating radiated energy, and (3) usage of construction materials capable of attenuating electromagnetic energy. A relatively new technique which may eventually replace meshes in walls and ceilings is metallic foil applied as wallpaper.

Unfortunately, electromagnetic interference personnel are unfamiliar with various problems associated with physically implementing shielding recommendations, and construction personnel are equally unaware of the importance of adhering to seemingly meaningless recommendations made by interference personnel. A compatible resolution of such problems is beyond the scope of this contract and the following recommendations are based solely upon electromagnetic interference requirements.

2.4.1 Attenuation Properties of Construction Materials.

Figure 19 is a graphical representation of the shielding effectiveness of various construction materials in attenuation of plane waves. Unfortunately, this contractor could find no other available data relative to the attenuation of commercially-available construction materials. A comprehensive study and evaluation of using commercially-available construction materials to perform the function of an electromagnetic shield cannot be realized until much more information is available on all such materials.

Results of Figure 19 would indicate that a shielding effectiveness of approximately 30 db can be realized by using concrete and carbon over a frequency range of 1 gc to 10 gc. A concrete coke aggregate appears to offer a shielding effectiveness in excess of 30 db above a frequency of 20 Mc and approaches 100+ db at around 300 Mc. Based on the above results a significant attenuation of plane wave energy can be realized by usage of concrete coke aggregate material in constructing walls, ceilings, and floors.

Information used on Figure 19 was obtained from the following source documents:

1. W.R. Cuming, "Materials for RF Shielded Chambers and Enclosures", Symposium Digest, 4th National Symposium on RFI, June 1962.
2. P.F. Nicholson, "Study of Coke-Aggregate Concrete as a Shield to Electromagnetic Radiation", NRL Report #5473, May 6, 1960.

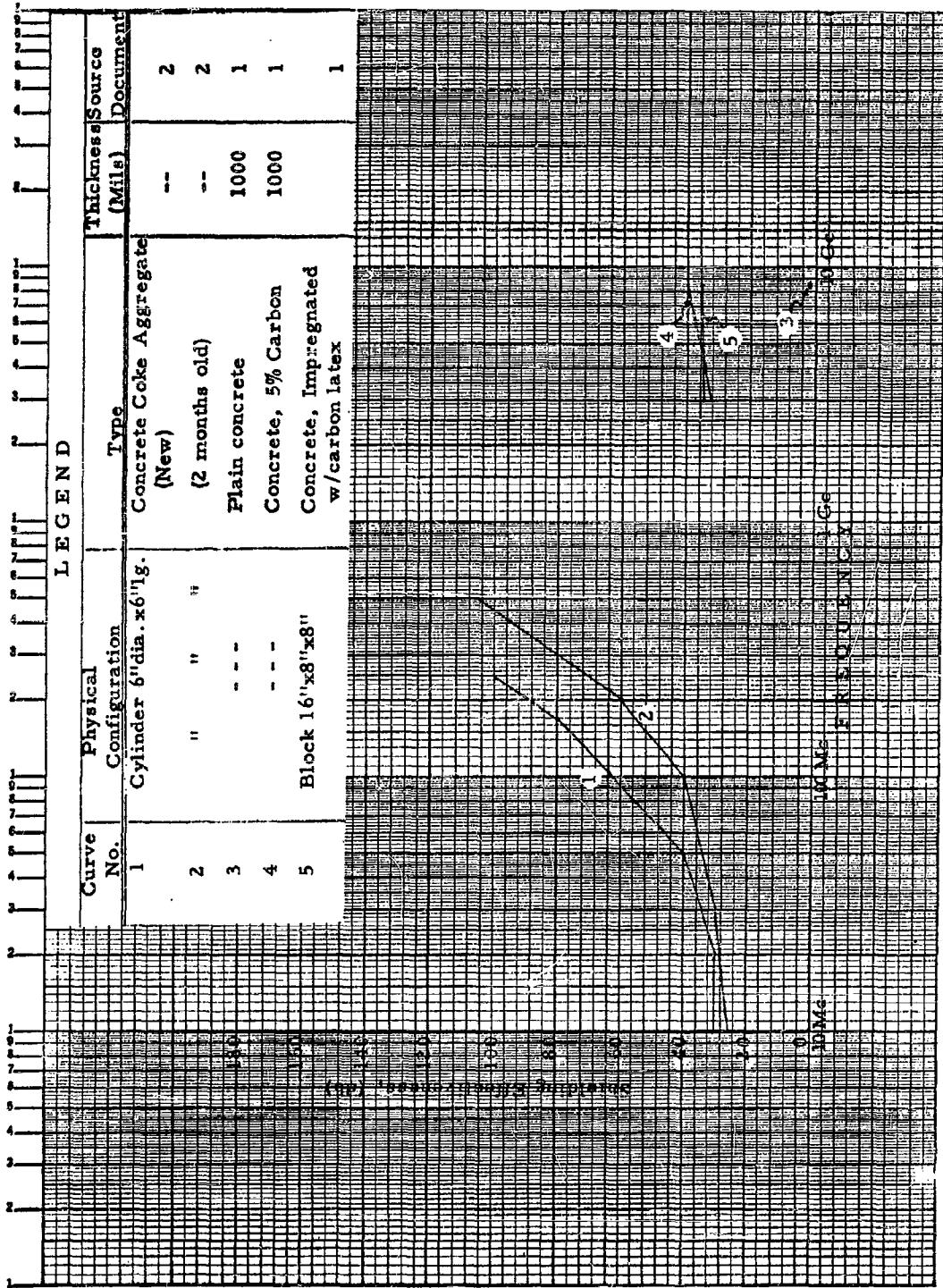

Figure 19 - PLANE WAVE MEASUREMENTS OF 5 FOR CONSTRUCTION MATERIALS.

2.4.2 Conductive Meshes In Walls, Floors, and Ceilings.

Figures 20 and 21 are graphical illustrations of the Magnetic and Electric Field shielding efficiency measured for various types of screen materials. Number 22 Copper screen mesh provides approximately 65 db attenuation of electric fields over a frequency range of .10 Kc to 1gc. Shielding efficiency decreases as screen aperture size increases and Number 2 galvanized steel screens provides an efficiency of 24 db over the same frequency range.

Number 60 copper screen provides 32 db magnetic field attenuation at 100 Kc, 5 db at 1 Mc, and 60 db at and above 20 Mc. Again, shielding efficiency decreases as the size of screen apertures increases.

It is recommended that all structures housing electronic equipments which are extremely susceptible to or capable of generating electromagnetic energy, include a conductive copper screen mesh of approximate size #60 as an integral part of wall construction. Such screening should be electrically continuous around the shell of the room to be shielded, which necessitates soldering of screens along corner junctions. Bonds of solid copper cables should be connected from the screen to the reference plane grid mesh.

If such extreme shielding measures are not necessary or warranted, an alternative method can be used to provide fairly effective shielding over the lower frequency ranges. This method would depend upon optimum usage of reinforcement bars to provide the electromagnetic shielding. Figure 22 indicates how reinforcement bars might be used to serve this purpose. Unfortunately no reliable data is known to exist relative to expected attenuation characteristics of such construction media.

2.4.3 Metallic Wallpaper

A relatively new material is becoming more popular relative to the attenuation of electromagnetic field energy: this material is metallic wallpaper. Although such material is not presently being used as a shielding technique to be considered during building construction, its possible merits of application warrant further consideration. It is believed by this contractor that such metallic foil may be quite effective if installed "within" walls where moisture is less prevalent and where such material will not be subjected to abusive wear and tear. However, such material is recommended for usage as a wallpaper and its merits as a construction shielding media must await further evaluation.

L E G E N D

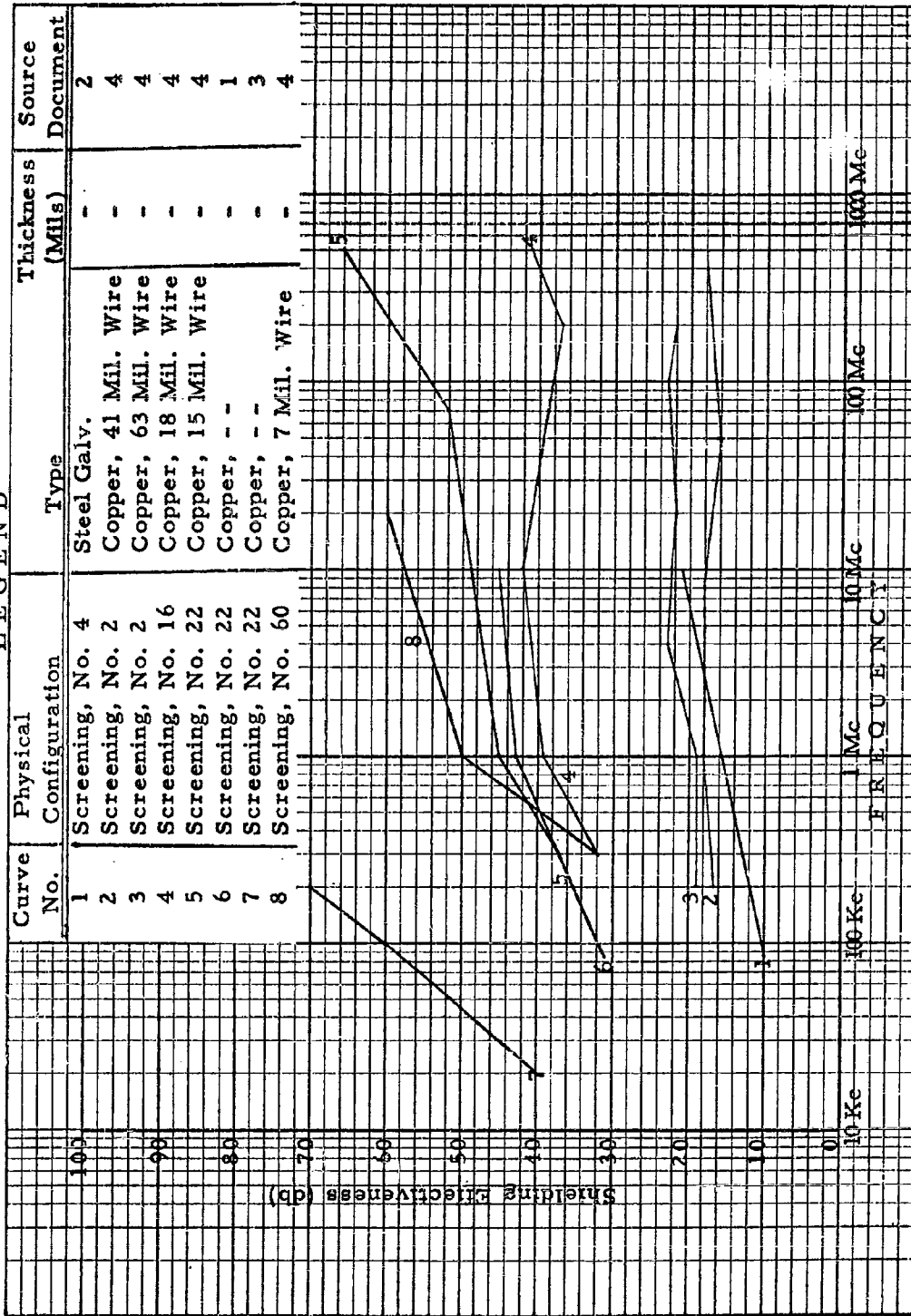

Figure 20 - LOW IMPEDANCE (H OR MAGNETIC) FIELD MEASUREMENTS OF 8 FOR SCREEN MATERIALS.

L E G E N D

Curve No.	Physical Configuration	Type	Thickness (Mils)	Source Document
1	Perforated Sheet 1/8" dia., 3/16" ctrs.	Steel	60	1
2	1/4" dia., 5/16" ctrs.	Aluminum	60	1
3	7/16" dia., 5/8" ctrs.	Aluminum	37	1
4	Screening, #2	30 Mil. Wire	-	1
5	Screening, #4	Galvanized Steel	-	2
6	Screening, #12	"	-	1
7	Screening, #22	Copper, 20 Mil. Wire	-	2
8	Screening, #16	Copper	-	2
		Aluminum, 20 Mil. Wire	-	1

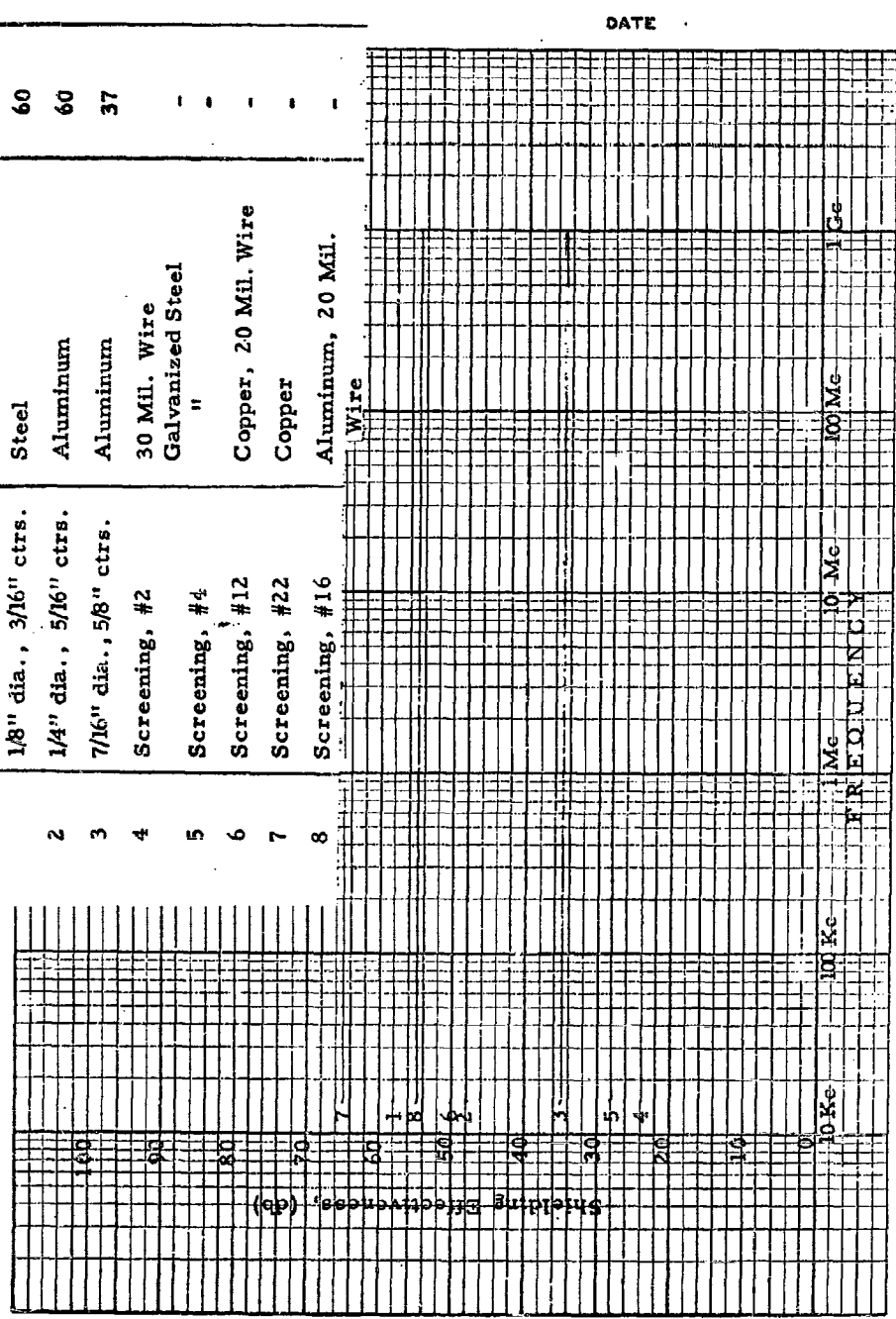

Figure 21 - HIGH IMPEDANCE (E OR ELECTRIC) FIELD MEASUREMENTS OF S FOR SCREEN MATERIALS.

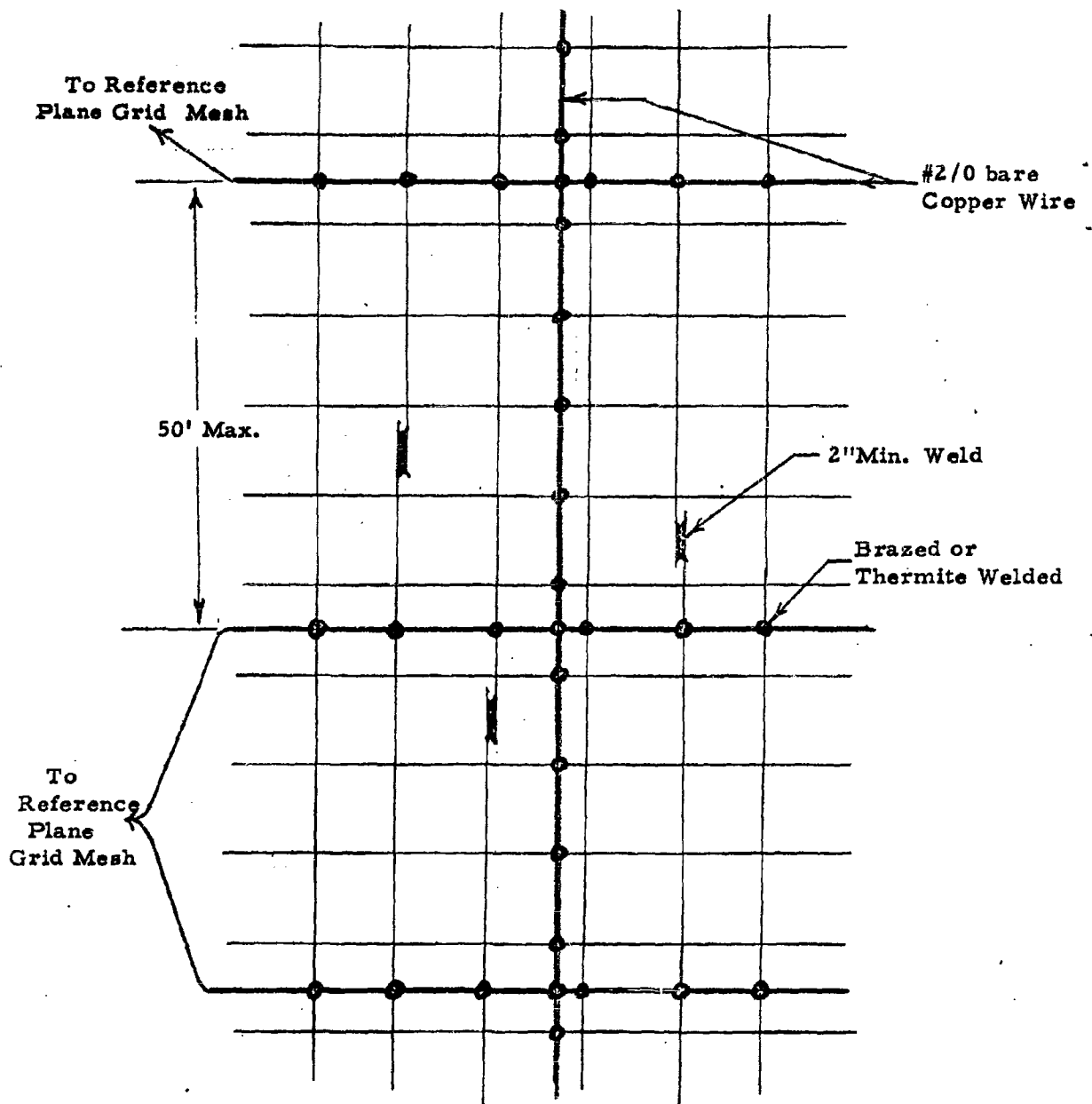

Figure 22. REINFORCEMENT BAR TIE-IN.

Information has been reprinted from Emerson and Cuming, Inc., Preliminary Technical Bulletin 11-2-9, concerning their metallic wall-paper and associated materials, Eccoshield WP, and is presented in Appendix V of this report.

2.4.4 Door and Window Design for Electromagnetic Field Attenuation

Accessibility to a structure is difficult to achieve while maintaining the shielding effectiveness of the structure. Doors installed in a shielded structure must be of metal construction and provide bonding between the door and structure. Two methods may be used to provide a satisfactory bond between the mating surfaces; RFI gasket material and metal finger stock. Metal finger stock is preferred, since the shielding effectiveness of the gasketing material is dependent upon the applied pressure. If the gasketing material is used for the bond, piano hinges must be used to maintain constant pressure on the gasket. Also, the metal finger stock requires a minimum of maintenance. The metal fingers should be welded to the door frame after the mating surfaces have been cleaned of paint, varnish, grease, etc. The metal door frame must be bonded to the building ground reference plane. As described in an earlier section, care must be made to insure that corrosion does not result from the use of dissimilar metals between the mating surfaces. Figure 23 is a sketch of a suitable bond connection between the door and building structure. Hinges will not be used as the bonding media between the two mating surfaces.

Three methods are available for maintaining the shielding effectiveness of a structure with windows. All three methods require a metal window frame bonded to the building ground reference plane. One method requires the installation of a thin screen over the window area and bonding the screen to the window frame. This method is preferred because of the ease of installation and reduced costs. Another method would be to install a commercially-available transparent conductive coated glass that must be bonded to the metal window frame by a gasketing material. This method may not be desirable, since the amount of light entering the room is greatly reduced by the frosted glass. A third method may be used, but the cost required to install this method may be prohibitive. This method would require the installation of a commercially-available product that is derived from the wave guide characteristics of a honeycomb structure. The mounting frame and gasketing are supplied with the product to provide ease in installation.

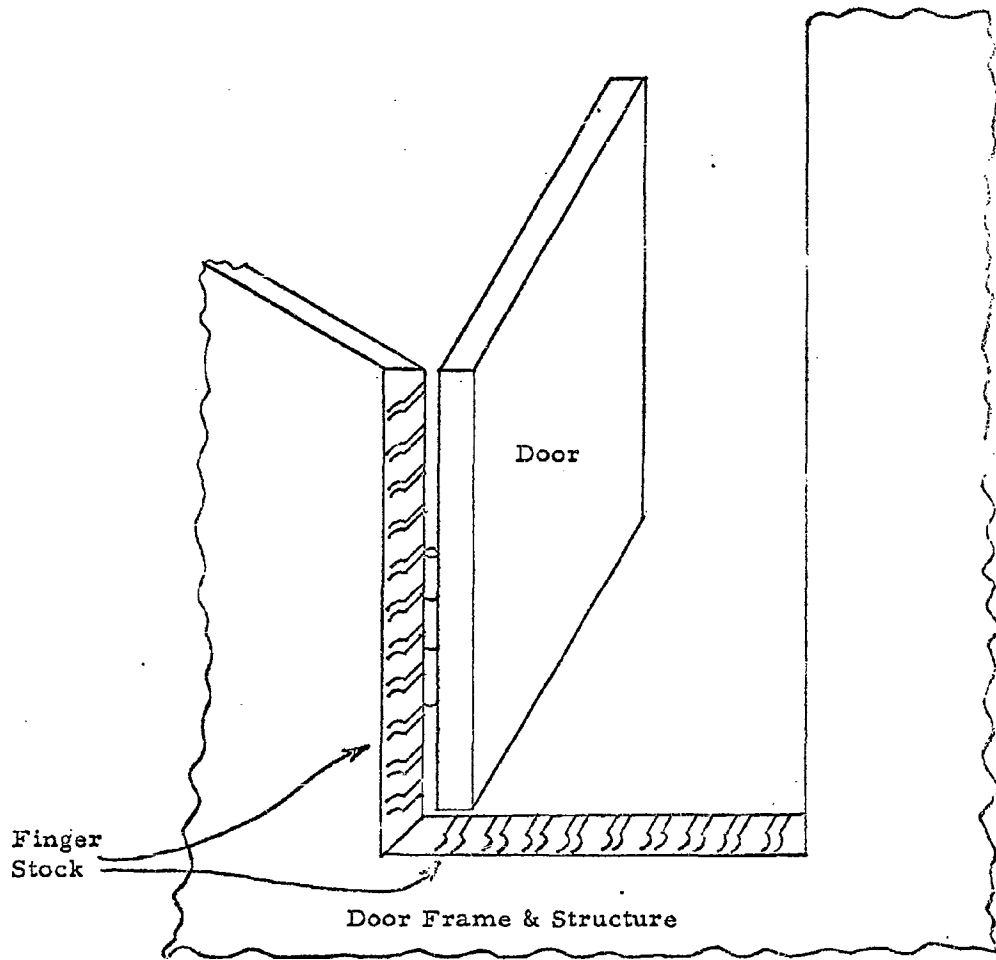

Figure 23. METHOD OF BONDING BETWEEN DOOR AND STRUCTURE.

3. CONSTRUCTION BELOW GROUND.

This section delineates the development of preferred techniques in establishing earth grounding and reference plane systems that are compatible with the requirements of various structure types and usages. Sample problems shall be presented to simplify the usage of resultant grounding criteria and complimentary techniques necessary for effective implementation of ground planes shall be described in detail.

In order to preclude any misun derstanding which may evolve due to word usage the following dictionary of terms is presented:

1. GROUND RODS.

Rods constructed of highly conductive metals which are driven into the earth and bonded to metallic masses above ground to preclude the development of potentials which may prove hazardous to personnel and equipment.

2. EARTH GROUND GRID MESHES.

Meshes constructed of highly conductive materials which are bonded together at all junctions, installed below the earth's surface and bonded to metallic masses above earth to replace or complement ground rods.

3. REFERENCE PLANE GROUND GRID MESH.

Highly conductive mesh construction above earth ground which serves the primary purpose of providing a low impedance reference plane (equipotential) for various shielding media and extraneous electronic users.

Earth grounding systems and reference plane systems serve two distinct functions and are therefore presented separately. Earth grounding systems generally will not suffice as reference planes as a result of relatively high earth resistance obtainable from optimum usage of ground rods and earth grid meshes. Optimum results are obtained from reference planes by connecting such planes to earth ground through a single ground well. Undesirable earth loop currents are isolated from the reference plane by usage of a single earth ground.

Underground water and pipe lines are an excellent media for connecting structural steel to earth ground due to the large amount of surface area exposed to the earth and relatively large depths which such

piping is buried in the earth to prevent freezing. It has been standard practice for many years to bond metallic structures above ground to water and gas pipes by means of copper bonds or copper ground rods. Copper in its various forms creates an undesirable coupling of dissimilar metals when in contact with iron or steel and acts as a cathode to accelerate corrosion of the less noble metal. Corrosion between the copper bond and the less noble metal will increase the bond impedance to such an extent that it must eventually be considered as "no" electrical bond at all. The resultant corrosion of underground and above ground piping systems is becoming so expensive to maintain that utility companies are beginning to use non-conductive pipes and couplings which will eliminate this widely used method of grounding, thereby presenting a significant problem of establishing effective economical grounds.

3.1 Ground Rods and Earth Ground Grid Meshes.

As a result of such earth grounding problems, it has become necessary to utilize ground rods and meshes to satisfy essential earth grounding requirements. The following discussions are presented for cases where water and gas pipes are not accessible for electrical grounding purposes, where necessary electrical grounding requirements cannot be realized by optimum usage of ground rods and meshes, and where ground rods and meshes are to be used in lieu of National Electrical Code requirements.

3.1.1 State-of-the-Art Earth Grounding Techniques.

The 1962 National Electrical Code reads as follows: "A metallic underground water piping system, either local or supplying a community, shall always be used as the grounding electrode where such a piping system is available. Where the buried portion of the metallic piping system is less than 10 feet (including well casings bonded to the piping system) or there is some likelihood of the piping system being disconnected or isolated through the use of non-metallic piping or insulated couplings, the piping system shall be supplemented by one or more of the grounding electrodes recognized in Sections 250-82 and 250-83".

National Electrical Code requirements are generally adhered to for industrial and commercial usage. Various private concerns and branches of the Armed Services prescribe techniques to be used to provide earth grounding of structures and equipments using ground rods and meshes. Copper ground rods are commonly used because this metal has long life when buried in the earth and has the best conductivity of commercially-available metals.

3.1.2 Design of Grounding System Utilizing Ground Rods.

Ground resistances are commonly computed either by application of the strict concepts of field theory or by the average potential method. Although the latter method is not absolutely exact from the standpoint of theoretical physics, it furnishes fairly accurate results and is readily adaptable to problems at hand. In recent years it has been accepted almost universally as the only practical means of solving problems of a more involved nature.

The grounding resistance of many closely-spaced parallel ground rods can be expressed by the following⁷:

$$R = \frac{\rho}{2\pi n L_1} \left[\log_e \frac{4L_1}{b} - 1 + \frac{2k_1 L_1}{\sqrt{A}} (\sqrt{n-1})^2 \right] \quad 3(1)$$

where:

- R = grounding resistance
- ρ = soil resistivity, ohm-centimeters.
- L_1 = length of each rod, cm.
- 2b = diameter of rods, cm.
- n = number of equally-spaced rods in area A
- A = area of rod coverage, cm.²
- k_1 = coefficient.

The derivation of the above expression is presented in Appendix I of this report.

The coefficient k_1 in Equation 3(1) is obtained from the expression $(\rho/\pi) (k_1/\sqrt{A})$ for the resistance of a horizontal thin plate. With L_1 increasing towards infinity Equation 3(1) approaches this value. The coefficients k_1 , for square and rectangular plates at each surface, are plotted as curve A in Figure 24⁸.

In most practical cases grids or rod beds are buried to depths much less than \sqrt{A} so that the coefficients k_1 for the surface level hold with sufficient accuracy. Further study and criteria shall be based upon values of k_1 for the surface level.

⁷ "Analytical Expressions for the Grounding Resistance of Grounding"
S. S. Schwarz, Transactions of AIEE, August 1954.

⁸ "Calculations of Resistance to Ground," A.B. Dwight, Transactions of AIEE, (Electrical Engineering) Vol. 55, December 1936, pp. 1-13.

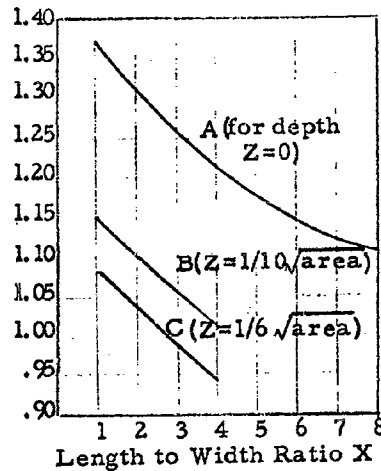

Figure 24. Values of Coefficient k_1 as function of length to width ratio X of of Area.

The determinations of soil resistivity as a function of locality where measured and depth of ground rod penetration cannot be practically realized with a high degree of accuracy. Effect of various terrain considerations upon soil resistivity and the accuracy of various methods of measuring soil resistivity are discussed in later sections.

Equation 3(1) has been rearranged and partially simplified as follows:

$$R = \frac{0.52\rho}{nL_1} \left[\log_e \frac{4L_1}{b} - 1 + \frac{2k_1 L_1}{\sqrt{A}} (\sqrt{n}-1)^2 \right] \quad 3(2)$$

where:

- ρ = soil resistivity (ohm-meter)
- L_1 = rod or pipe length (ft.)
- b = 1/24 rod or pipe dia. (in.)
- n = number of parallel rods
- A = Area (sq. ft.) between rods at farthest outside position.

Equation 3(2) has been used to calculate ground resistance as a function of (1) number of evenly-spaced rods, (2) area of coverage, and (3) depth of earth penetration. Resultant data is presented graphically in Figure 25. Figure 25 can be simply used to predict ground rod configuration compatible with the requirements of a specific situation. Calculations have been based upon a value of soil resistivity equal to 50 ohm-meters. Earth resistance resulting from soil resistivities other than

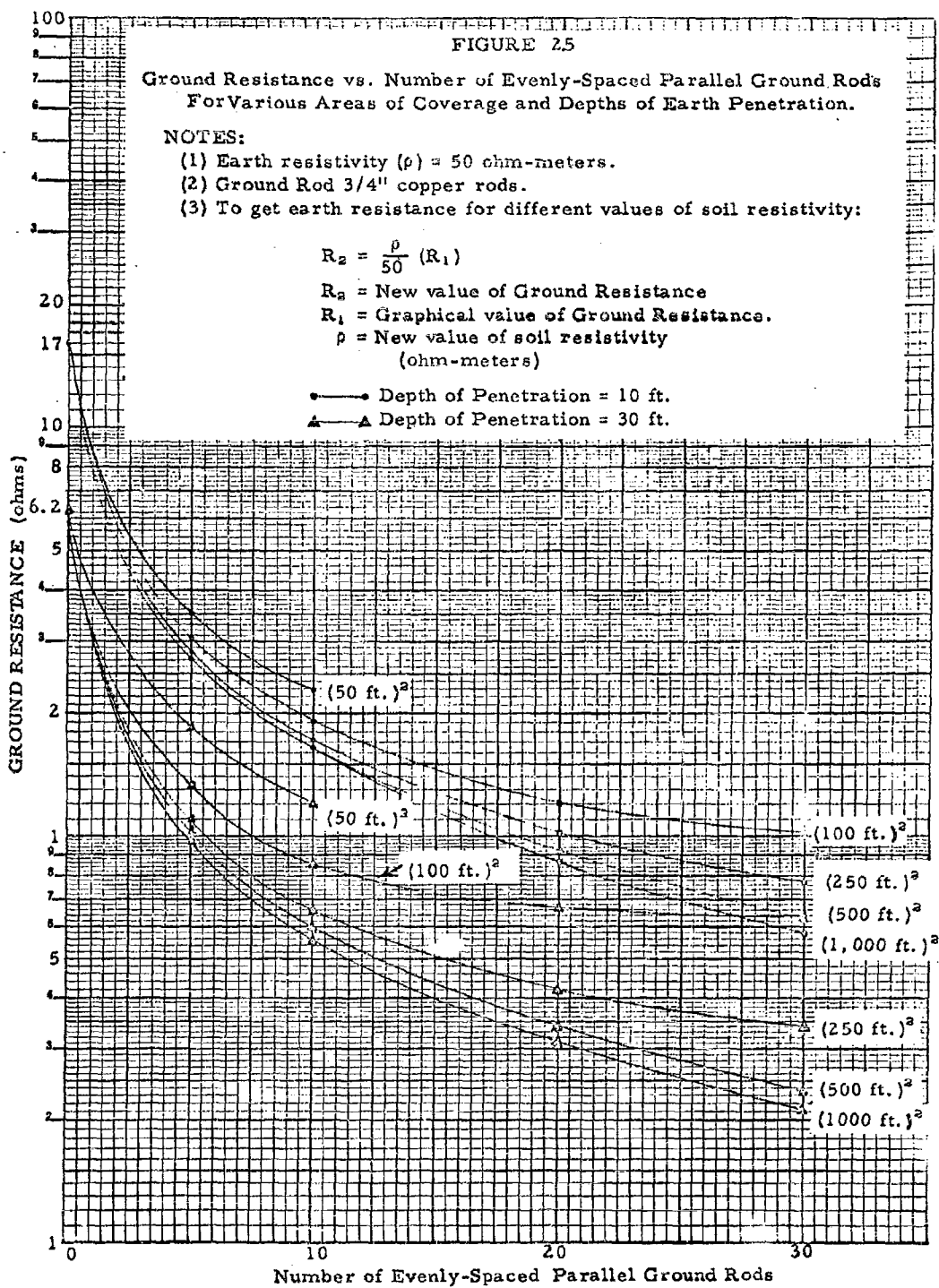

the assumed value can be calculated as follows:

$$R_1 = R \left(\frac{\rho_1}{\rho} \right) \quad 3(3)$$

where:

R = grounding resistance obtained from Figure 25

ρ = 50 ohm-meters

ρ_1 = measured value of soil resistivity (ohm-meters)

Numerous example situations are illustrated in this section which exemplify the methods using Figure 25. All inclusive ground rod recommendations cannot be made due to the associated parameters which may vary drastically from situation to situation.

(a) Building type constructions requiring low resistance earth connections.

Example 1. PROBLEM: An earth grounding system is required for a proposed building with foundation dimensions of 150' x 50'. Terrain considerations allow penetration of long ground rods and a soil resistivity of 25 ohm-meters was measured at a depth of 15 feet. The intended usage of the building necessitates the requirement that a grounding resistance of no greater than 1 ohm shall exist. Determine the required number of ground rods, depth of penetration, and area of coverage to realize the desired ground resistance.

ANSWER: The foundation area will be 150' x 50' = 7500 ft.². The soil resistivity, ρ , is 25 ohm-meters, or 1/2 the value used for calculating data used to obtain Figure 25. Therefore, 2 ohms on Figure 25 is equivalent to the 1 ohm ground resistance required.

The required grounding resistance can be obtained in the following ways from Figure 25.

(1) Ten (10), 3/4-inch rods, evenly-spaced over a 7500 ft.² area, and driven to a depth of ten (10) feet each ($R \approx 1$ ohm).

(2) Three (3), 3/4-inch rods, evenly-spaced over a 7500 ft.² area, and driven to a depth of thirty (30) feet each ($R \approx 1$ ohm).

Sufficient tolerances should be added to allow for (1) increase in grounding resistance due to age and corrosion, (2) resistance of rods and tie-cables, (3) bonding resistance resulting from structure to

rod and/or tie cables, and (4) variations in soil resistivity. Tools that can be used to obtain the decreased resistance are (1) depth of penetration, (2) number of rods and (3) area of coverage. A 50% tolerance should provide substantial allowance; therefore the resultant resistance requirement will be .5 ohms. This requirement may be realized in any one of the following ways:

(3) Ten (10), 3/4-inch rods, evenly-spaced over a 7500 ft.² area, and driven to depths of 30 ft. each ($R \approx .5$ ohms)

(4) Seven (7), 3/4-inch rods, evenly-spaced over a 12000 ft.² area, and driven to depths of 30 ft. each ($R \approx .5$ ohms).

Obviously other combinations can be selected from Figure 25 which will result in the required grounding resistance. However, solution #4 appears the most economical to implement without relying on greater depths of penetration.

Example 2: PROBLEM: Consider a building identical to Example 1, except that the grounding requirement is that the grounding resistance should be as low as possible from a practical and economical viewpoint.

ANSWER: Very little resistance reduction is obtainable from a practical degree of increase in the area of coverage. Maximum benefit will be derived from optimum usage of the depth of rod penetration and number of rods used.

The smallest resistance obtainable for a thirty (30) foot rod penetration and a coverage area of 7500 ft.² is approximately 0.37 ohms. However, twenty (20) rods driven under identical conditions provides a resistance of 0.35 ohms, and any increase in number of rods over this amount is unwarranted. Only 0.01 ohms difference in resistance is obtained by increasing the area of coverage from 7500 ft.² to 10,000 ft.² when using twenty rods (20) driven to a depth of 30 ft. The relatively small resistance reduction is not practical from an economical viewpoint.

The most logical rodded selection is therefore as follows:

Twenty (20) 3/4" rods driven to a depth of 30 feet or more, and evenly-spaced over an area of 7500 ft.² ($R \approx 0.35\Omega$).

Example 3: PROBLEM: Consider a building identical to Example 1, except that the building is intended to house critical instrumentation facilities and the ground resistance is required to be ≤ 0.25 ohms. Such resistance should be practically constant with seasonal change and temperature fluctuations.

ANSWER: Since ground resistance is critical, a tolerance of 50% should be allowed to insure consistent compliance with specified requirements. Resistance fluctuations might be expected due to factors stipulated in Example 1. In order to insure constant ground resistance as a function of climatic changes, rods should be driven near the permanent water level if possible.

The required ground resistance is $0.25 \text{ ohms} - 0.50$ ($.25$) ohms = 0.125 ohms. Using information on Figure 25 only areas of coverage in excess of $250,000 \text{ ft.}^2$ utilizing 30 evenly-spaced rods driven to a depth of 30 feet, will result in the specified grounding resistance. This approach is unpractical due to the extensive area of coverage and large number of ground rods required. Figure 25 therefore, cannot be used to obtain a satisfactory solution to the problem.

Equation 3(2) must be used to calculate the resistances resulting from usage of various factors capable of reducing the resistance to specified limits at a reasonable cost. For example, if rods could be driven to the permanent water level where the soil resistivity might be measured as 12.5 ohm-meters, the extra length of rod penetration would reduce the required area of coverage and number of rods to practical values.

In lieu of the above approach, a ground grid might be utilized in conjunction with ground rods to obtain the desired ground resistance. A discussion of ground grids is presented in a later section of this report.

3.1.3 Materials to be Used in Ground Rods, Size and Coatings.

Copper ground rods are commonly used for grounding purposes due to their high conductivity and apparently high corrosion resistance properties. Figure 26 illustrates the physical makeup of existing ground rods that have proven both effective and capable of being driven to great depths. Such rods come in a variety of sizes but the 3/4-inch diameter rod appears to be the most compatible with electrical and mechanical requirements.

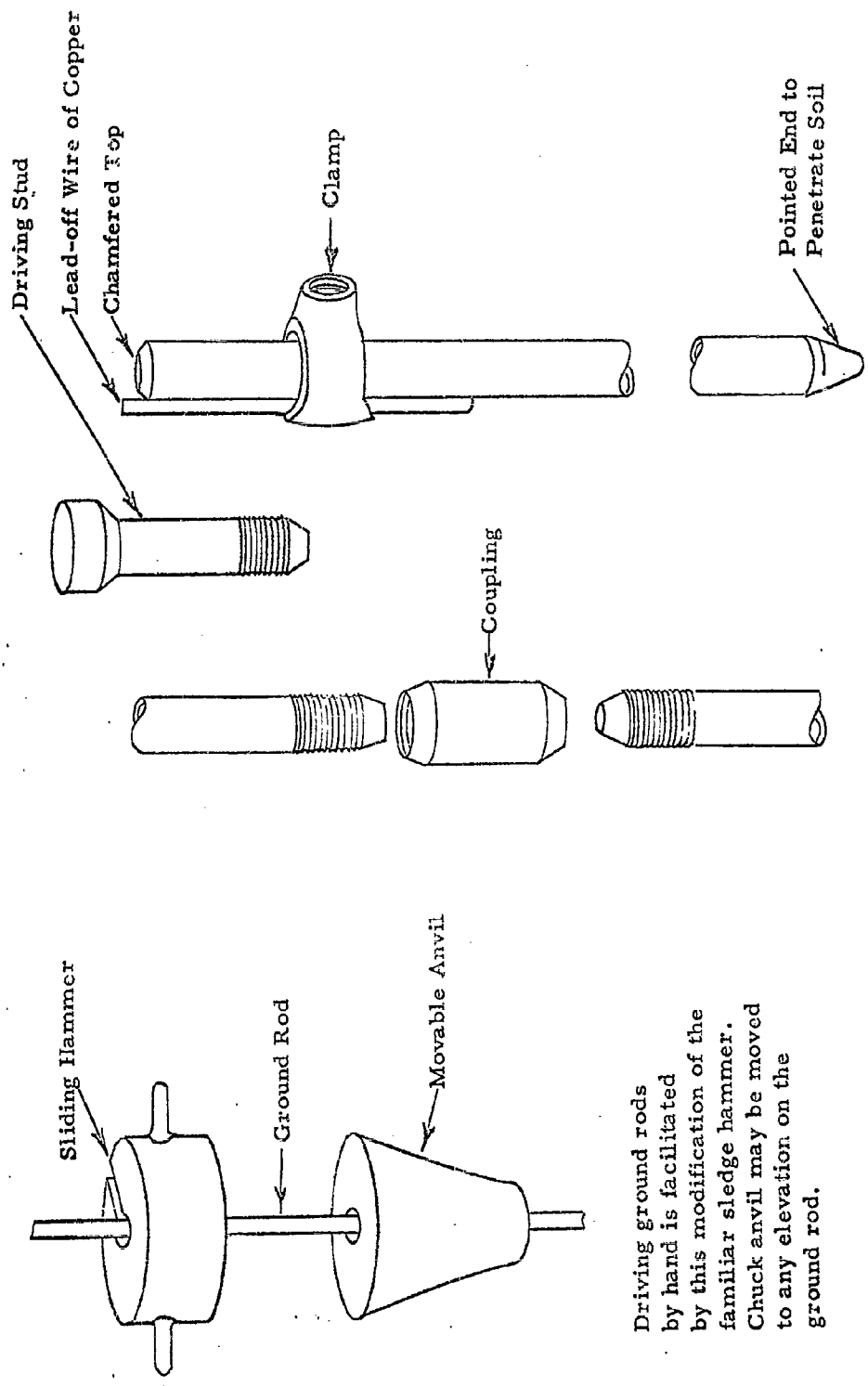

Driving ground rods by hand is facilitated by this modification of the familiar sledge hammer. Chuck anvil may be moved to any elevation on the ground rod.

Figure 26. PHYSICAL CHARACTERISTICS OF TYPICAL GROUND RODS.

The effects of corrosion must be considered in the selection of compatible ground rods. The following are established facts regarding corrosion: (1) in most cases, both water and oxygen are necessary for corrosion, (2) the initial rate of corrosion is usually comparatively rapid, slowing as protective films form, (3) surface films are important in controlling the rate and distribution of corrosion, (4) increased rate of motion increases corrosion in water, and (5) dissimilar metals in contact accelerate corrosion of the one that happens to be anodic.

As previously stated, copper is exceptionally corrosion-resistant, however, copper is anodic to various metals used underground for piping and construction purposes. It would therefore be desirable to coat copper grounding rods with a material having the following properties: (1) less anodic to metallic objects located in near vicinity underground, (2) high electrical conductivity, (3) high corrosion resistance, and (4) galvanically compatible with the base metal.

Tin coatings on copper and copper alloys are normally anodic to the base metal, as indicated in Table VI. The tin-copper alloy layer, formed in coating by hot dipping, is cathodic to tin and may be slightly cathodic to copper. Pores in the coating are not usually sites of corrosion attack on copper, and in general the corrosion of tinned copper is essentially corrosion of the tin. The function of tin coatings is usually to provide, between copper and the material in question, a layer which if corroded at all will yield as innocuous a corrosion product as possible.

The advantage realized from deep-driven ground rods was discussed in the previous section. Such advantage is realized due to the decreased soil resistivity and increased volume of earth associated with deep rods. However, as indicated in Table V metal corrosivity increases as soil resistivity decreases, which imposes more stringent requirements on the corrosion-resistant properties of ground rods.

Table V. Metal Corrosivity as a Function of Soil Resistivity

Resistance in Ohms per cubic centimeter	Severity of Possible galvanic effects
Less than 400	Extremely severe
400-900	Very Severe
900-1,500	Severe
1,500-3,500	Moderate
3,500-8,000	Mild
8,000-20,000	Slight

Table VI
Electromotive Force Series
for Metals

Magnesium	
Aluminum	
Zinc	
Chromium	(Metals are listed in decreasing order of tendency to go into solution as ions).
Iron	
Cadmium	
Nickel	
Tin	
Lead	
Copper	
Silver	

Two promising groups of alloys which may be valuable in the prevention of galvanic corrosion, are the austenitic irons (SDTMA-439 Type D2) and austenitic stainless steel of the 18% chromium and 8% nickel variety. However, much additional research is required to evaluate the effectiveness of such materials for use in conjunction with grounding.

It is recommended that ground rods be constructed of copper which has been hot-dipped in tin to reduce galvanic corrosion of the less noble metals and provide necessary electrical grounding requirements. Rods such as those illustrated in Figure 26 should be used where deep penetration is required. Other types of rods must incorporate means of insuring low impedance connections between sections. Rod size must be dictated by mechanical requirements as well as electrical, but should not be less than 3/8-inch in diameter.

3.1.4 Method for Connecting Ground Rod to Structure and Grid Mesh.

Figure 27 illustrates preferred techniques for connecting ground rods to structures and grid meshes. The portion of the ground wire making contact between the Joslyn washer and the base shoe should be tinned to reduce the effects of galvanic corrosion. All bolts and nuts should be securely tightened to prevent bond deterioration with age and wear. Indicated bonds should be coated with a moisture-proof coating

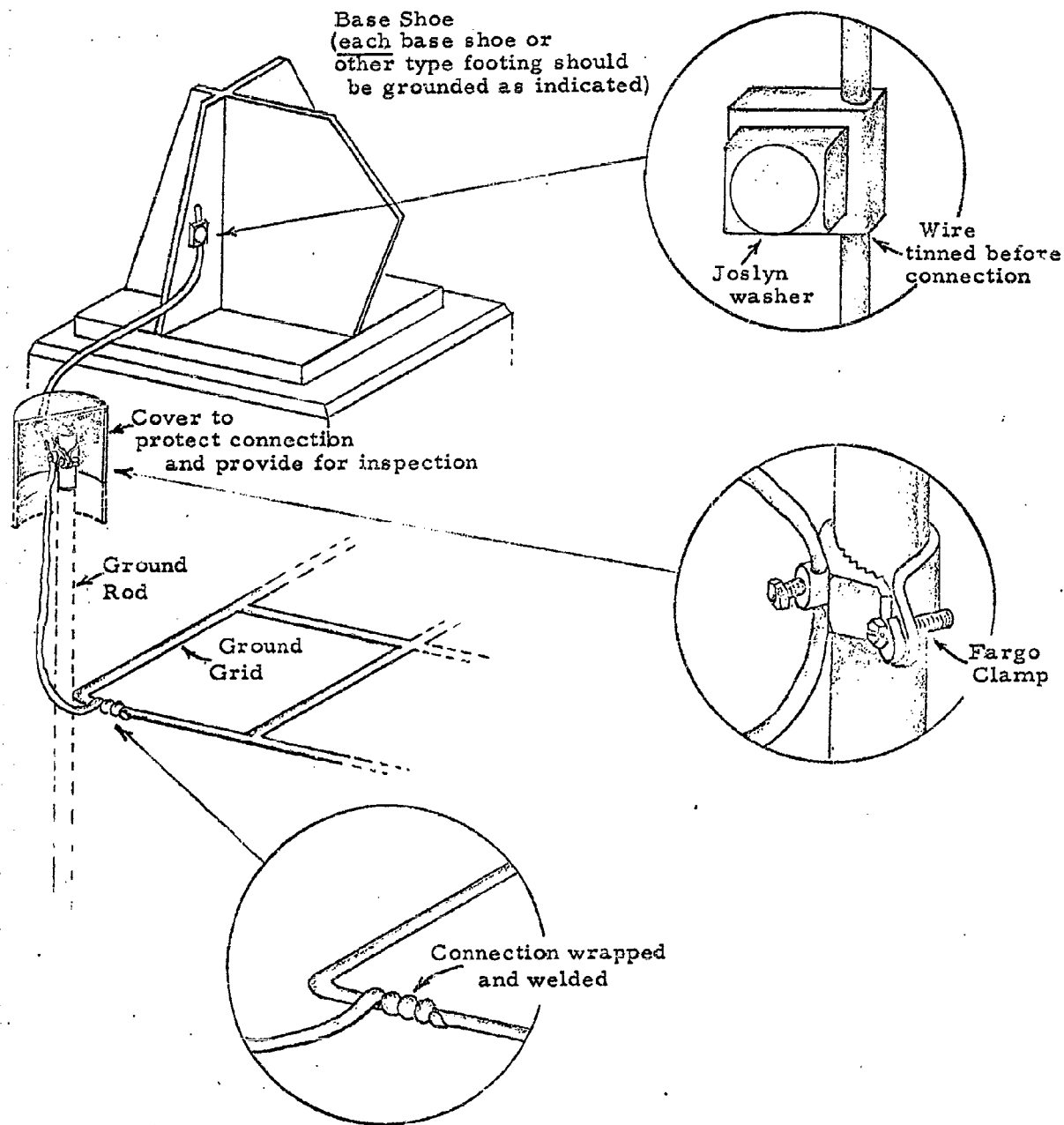

Figure 27. METHOD FOR CONNECTING GROUND RODS TO STRUCTURE AND GRID MESH.

capable of maintaining its physical properties over an extended period of time. The cover which is placed over a portion of the ground rod extending above the surface of the earth may be of a non-conducting media as long as it remains waterproof over an extended period of time. Such covers should be removable or provide entrance to facilitate periodic inspection of the ground rod connection and measurement of earth resistance. The bonding cable can be of 4/0 or solid 1/4" copper wire, or larger sizes. Techniques displayed in Figure 27 can be applied to all types of building structures with steel frames and base shoes.

Figures 28, 29, and 30 illustrate preferred techniques for grounding various types of towers. Where connections are made below ground (imbedded in concrete excluded) a protective waterproof coating should be applied. In those cases where bonding wires are mated to structural steel, bonding wires should be tinned before connection is made.

3.1.5 Terrain Considerations.

Preceding ground rod and grid mesh criteria has been developed upon the assumption that a sufficiently low earth resistivity can be realized for effective implementation. Obviously, in extremely rocky or frozen soil, deep penetration of ground rods is impractical. In such cases ground grids might be used but in regions subjected to extreme climatic variations earth resistivity will vary considerably which will cause earth resistance variations in shallow buried grid meshes. In various localities such as dry sandy soils, earth resistivity may be extremely high regardless of the depth of ground rod penetration. In situations such as these, techniques such as the following may be utilized to obtain the necessarily low ground resistance: (1) impregnation of soil with salt solution, (2) immersion of grid or plate in nearby water sources and connection of such grounding media to structures to be grounded, or (3) utilization of available underground piping systems.

Resistivity Variations as a Function of Soil Type

The ground resistance of any type of electrode that may be used is directly proportional to ρ , the resistivity of the soil. Consider a metallic hemisphere of radius "a" which is buried flush with the surface of the earth as shown in Figure 31. If the resistance of the electrode itself is neglected, the resistance of the earth connection will be that offered to the current flow through the soil volume immediately surrounding the electrode. This resistance may be calculated as follows:

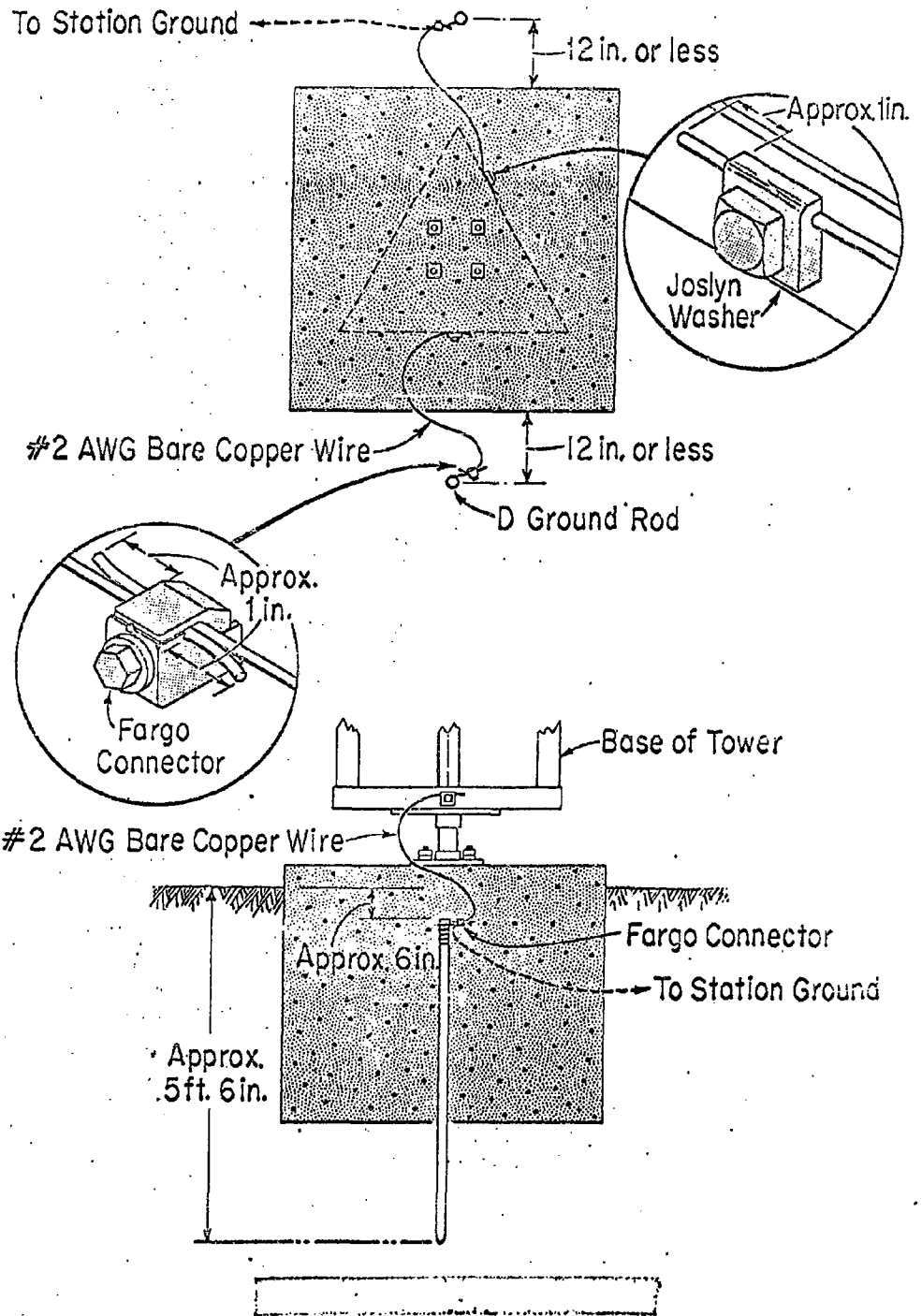

Figure 28 -GROUNDING AT FOUNDATION OF GUYED TOWER.

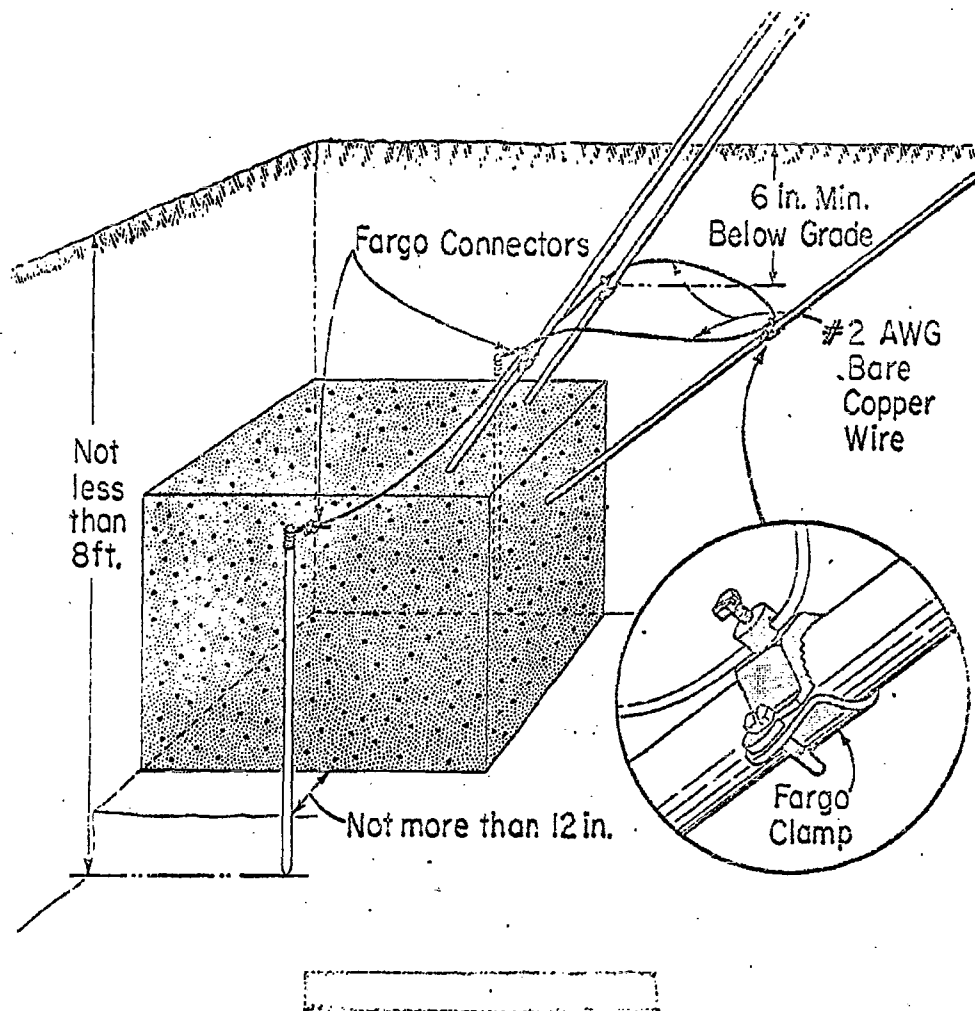

Figure 29 -GROUNDING AT ANCHOR OF GUYED TOWER.

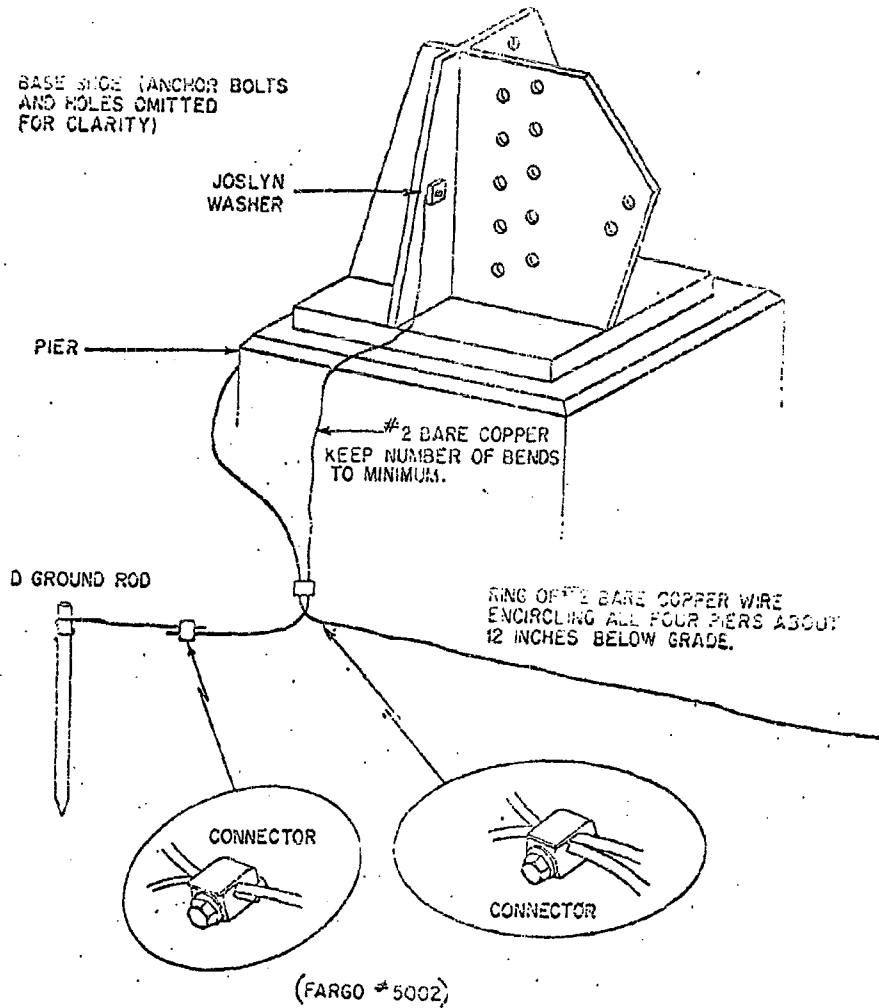

Figure 30 -GROUND CONNECTION AT BASE SHOE FOR SELF-SUPPORTING TOWERS.

$$\text{Resistance of a conductor} = \rho \frac{l}{A}$$

3(4)

where:

- ρ = resistivity of conductor material
- l = length of conductor
- A = cross-section of conductor

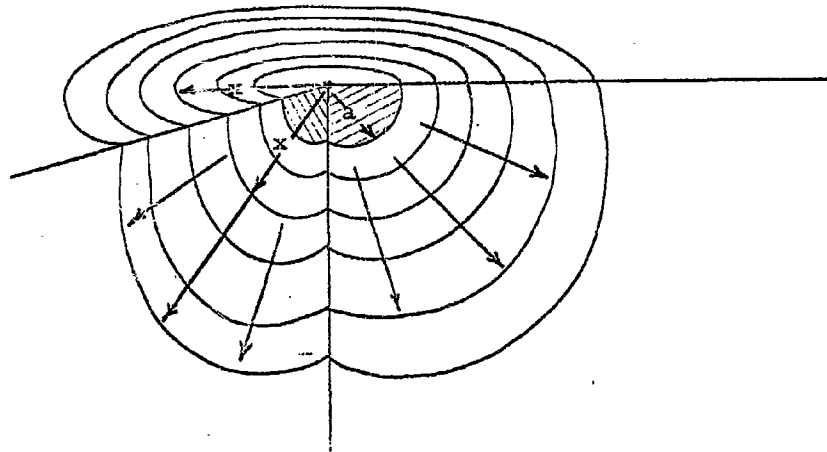

Figure 31. DISTRIBUTION OF CURRENT ABOUT A METALLIC HEMISPHERICAL GROUND ELECTRODE OF RADIUS a . ARROWS INDICATE LINES OF CURRENT FLOW.

Table VII
The Resistivity of Different Soils

Soil	Resistance* (ohms)			Resistivity (ohms per cm. cube)		
	Avg	Min	Max	Avg	Min	Max
Fills:						
Ashes, Cinders, Brine Waste.....	14	3.5	41	2,370	590	7,000
Clay, Shale, Gumbo, Loam.	24	2	98	4,060	340	16,300
Same, with varying proportions of sand & gravel.....	93	6	800	15,800	1,020	135,000
Gravel, sand, stones with little clay or loam.....	554	35	2,700	94,000	59,000	458,000

* Bureau of Standards Technical Report No. 108.

$$\text{Resistance of electrode to ground} = R = \rho \int_a^{\infty} \frac{dx}{2\pi x^2}$$

$$R = \frac{\rho}{2\pi a} \quad 3(5)$$

Earth resistivity is variable as a function of (1) soil type, (2) temperature, and (3) moisture content. Table VII shows data collected for various types of soil without regard to the temperature or moisture content. From this table it is obvious that a grounding system which is entirely adequate in clay soil will be almost worthless in sandy soil.

Resistivity Variations as a Function of Moisture Content

Soils that are relatively good conductors under normal amounts of moisture content become very good insulators when such content is low. Figure 32 and Table VIII show the variation of soil resistivity with moisture content for various soil types. For most soil types moisture content of 30% will result in a sufficiently low resistivity per cubic centimeters.

Resistivity Variations as a Function of Temperature

Soils that have sufficient moisture content to be good conductors at normal temperatures will become ineffective due to increased resistivity at lower temperatures. Figure 33 and Table IX illustrate soil resistivity changes as functions of temperature change for two different soil types.

Resistivity Variations Due to Salt Content.

Soil Resistivity varies as a function of the salt content of the soil. Figure 34 and Table X show the effects of salt content upon reduction of the resistivity of various types of soil. Soil can be artificially treated with salt to increase the conductivity. Figure 35 is a plot of the test data taken showing resistance variations as a function of time for a specific ground connection.

For all structures requiring a low resistance earth grounding system where the required low resistance earth ground cannot be obtained by usage of rods or grids due to terrain considerations, the following techniques may be used: (1) artificial salting of soil, (2) immersion of grid or plate connected to the structure to be grounded, in nearby water source, (3) or utilization of available underground piping systems or metallic well casing.

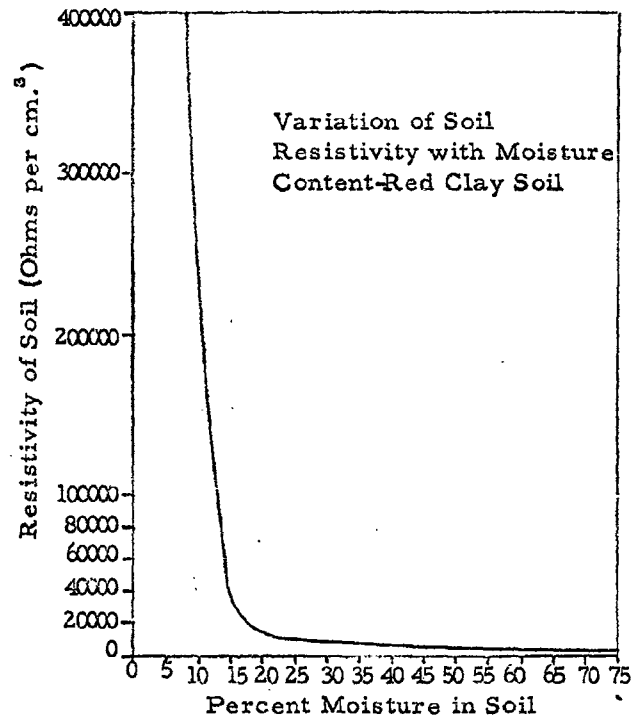

Figure 32. RESISTIVITY OF RED CLAY SOIL DROPS RAPIDLY AS ITS MOISTURE CONTENT INCREASES TO ABOUT 15% BY WEIGHT.

Table VIII
The Effect of Moisture Content
on the
Resistivity of Soil*

Moisture Content % by Wt.	Resistivity (ohms per cm. ³)	
	Top Soil	Sandy Loam
0	>1,000 x 10 ⁶	>1,000 x 10 ⁶
2.5	250,000	150,000
5	165,000	43,000
10	53,000	18,500
15	19,000	10,500
20	12,000	6,300
30	6,400	4,200

*"An Investigation of Earthing Resistances" by P. J. Higgs, I. E. E. Journal, Vol. 68, p. 736, February, 1930.

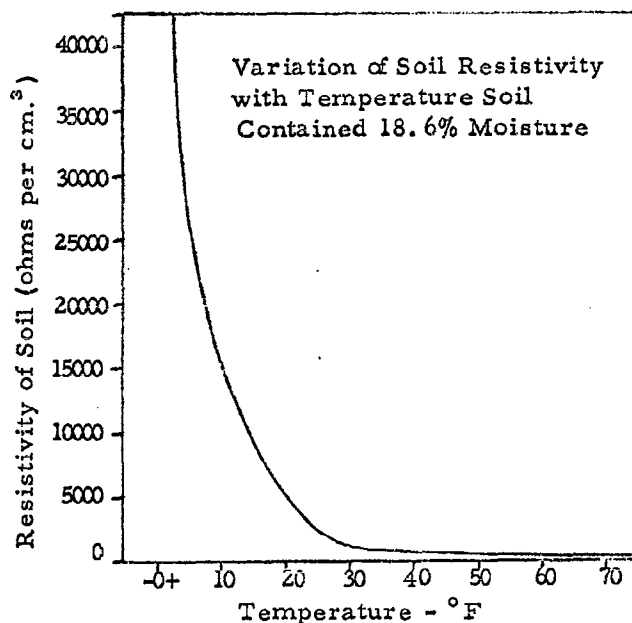

Figure 33. RESISTIVITY OF RED CLAY SOIL DIMINISHES AS TEMPERATURE RISES IN A SAMPLE CONTAINING 18.6% MOISTURE.

Table IX

The Effect of Temperature on
The Resistivity of Soil *

(Sandy Loam 15.2 percent moisture)

Temperature		Resistivity (Ohms per cm. ³)
C	F	
20	68	7200
10	50	9900
0(water)	32	13,800
0(ice)		30,000
-5	23	79,000
-15	14	330,000

*'Lightning Arrester Grounds, Parts I, II, and III', by H. M. Towne, General Electric Review, Vol. 35, pp. 173, 215, and 280, March, April and May 1932.

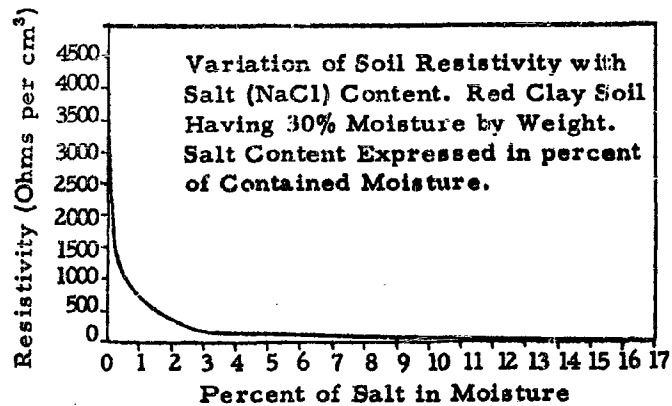

Figure 34. EFFECT OF ADDITION OF SALT UPON RESISTIVITY OF RED CLAY SOIL.

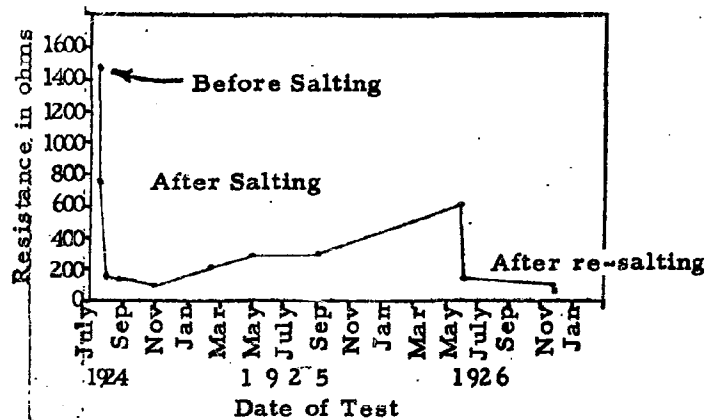

Figure 35. CHANGES IN RESISTANCE OF A GROUND CONNECTION IN RESPONSE TO PRESENCE OF SALT OVER A CONSIDERABLE PERIOD.

Table X
 The Effect of Salt Content on The
 Resistivity of Soil *
 (Sandy Loam. Moisture Content, 15% by Weight
 Temperature 17°C.)

Added Salt (% by Weight of Moisture)	Resistivity (Ohms per Cm. Cube)
0	10,700
0.1	1,800
1.0	460
5	190
10	130
20	100

* "An Investigation of Earthing Resistances," by
 P. J. Higgs, I. E. E. Journal, Vol. 68, p. 736, Feb 1930.

3.1.6 Methods for Approximating Soil Resistivity.

It is necessary to know, at least approximately, the value of soil resistivity existing in an area where a structure requiring an earth ground is to be built. Previous discussions and resultant criteria have been based upon the assumption that an approximate value of soil resistivity will be available for design purposes.

After grounding systems have been implemented, techniques must be available for insuring that resultant systems produce the specified grounding resistance. Ground resistance can be expected to fluctuate as a result of climatic changes, age, and wear and must be periodically checked to insure compliance with stipulated specifications.

Ground resistance test requirements vary from situation to situation, and various techniques must be available which are compatible with the requirements of all situations. The following paragraphs describe various techniques that can be used to test the ground resistance of grounding systems and of the soil itself.

Fall-of-Potential Method.

Figure 36 illustrates a typical test setup for measuring the grounding resistance by the fall of potential method. This method is widely used and has been proven to be very practical and reliable. It is best done

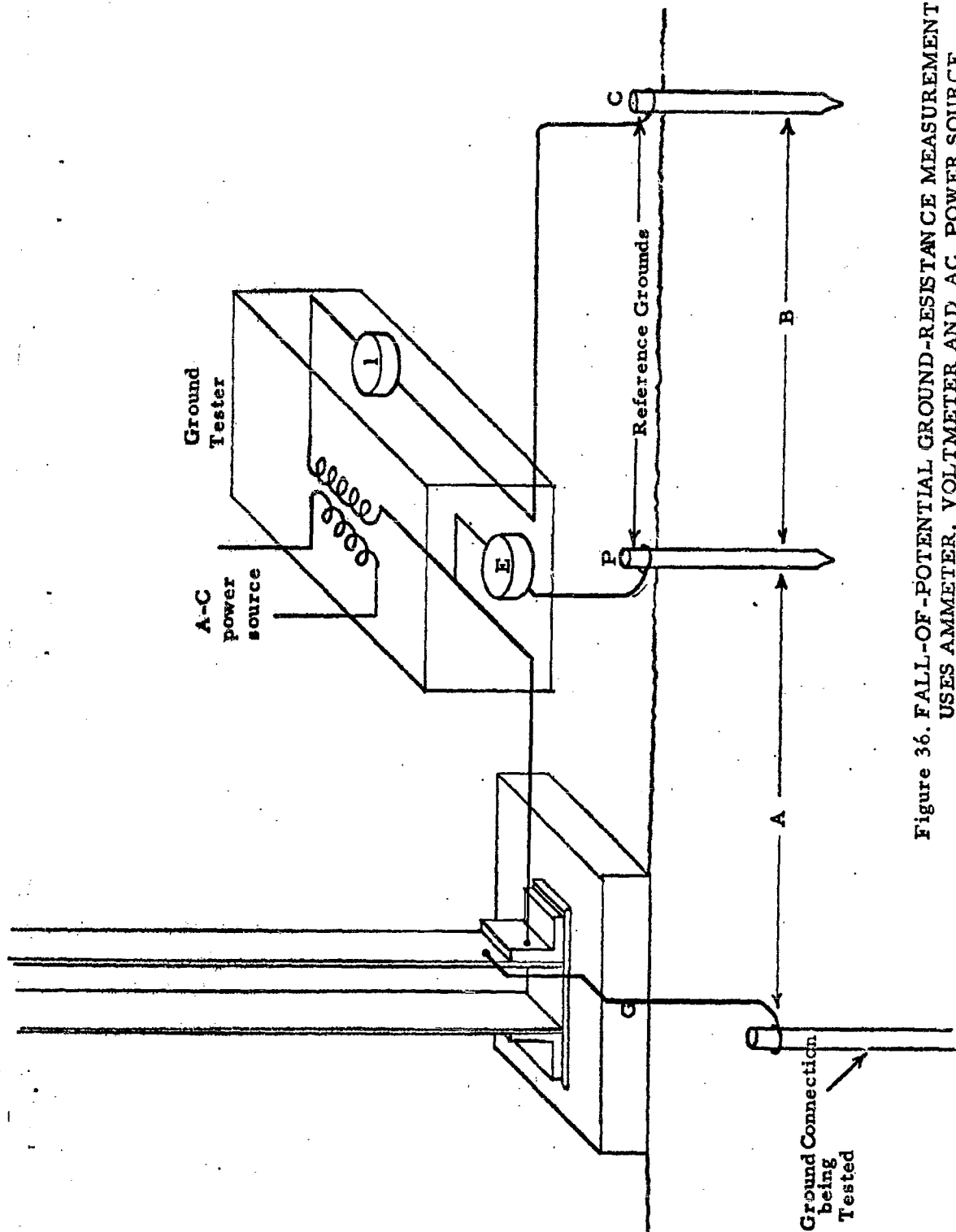

Figure 36. FALL-OF-POTENTIAL GROUND-RESISTANCE MEASUREMENT
 USES AMMETER, VOLTMETER AND AC POWER SOURCE,
 OR SELF-CONTAINED AUTOMATICALLY-COMPENSATED
 GROUND TESTER.

with a tester designed for the purpose, although it can be performed with an ammeter and voltmeter. There are several complications, however, which the ground tester automatically takes care of. Test current should be AC, preferably not of power frequency, if ground currents, (which are often considerable) are not to interfere with meter readings. DC is unsatisfactory, because it polarizes electrodes, giving false resistance values for ground connections. Under ordinary conditions for rod or pipe grounds down to eight (8) feet in the earth, distance "A" (see Figure 36) should equal "B", and should be about 50 feet. For large area grounds, such as tanks, "A" should be five (5) or more times the length of the longest diagonal across the area covered by ground, with "B" equal to 100 feet or more. Using an ammeter or voltmeter, ground resistance is found by dividing voltage by current. Ground resistance testers are read directly in ohms, and contain all elements, including an AC source that is driven by handcrank.

Four-Point Array

A four-point array is illustrated in Figure 37, in which C_1 and C_2 are current terminals; and P_1 and P_2 are potential points. The distance s (See Figure 37a) corresponds to $C_1 P_1$ and S_1 corresponds to $C_2 P_1$; similarly for $C_1 P_2$ and $C_2 P_2$.

Wenner Array⁹ The Wenner Array was an "in-line" array of the current and potential points (or stakes) as shown in Figure 38. A uniform spacing between stakes is employed and since $C_1 P_1 = a$, $C_1 P_2 = 2a$, etc., we have

$$\sigma = \frac{1}{2\pi R_s} \left(\frac{1}{a} + \frac{1}{a} - \frac{1}{2a} - \frac{1}{2a} \right) = \frac{1}{2\pi A_s R_s} \quad \text{mho-m/sq. m.} \quad 3(5)$$

with a in meters, or

$$\sigma = \frac{0.1523}{A_s R_s} \quad \text{mho-m/sq. m.} \quad 3(6)$$

with a in feet. R_s is, of course, $V_{P_1 P_2} / I$.

Eltran Array. The Eltran Array also was an "in-line" arrangement of stakes with a uniform spacing of "a" meters but differs

⁹ A Method of Measuring Earth Resistivity by Frank Wenner, Bulletin U.S. Bureau of Standards, Vol. 12, 1916.

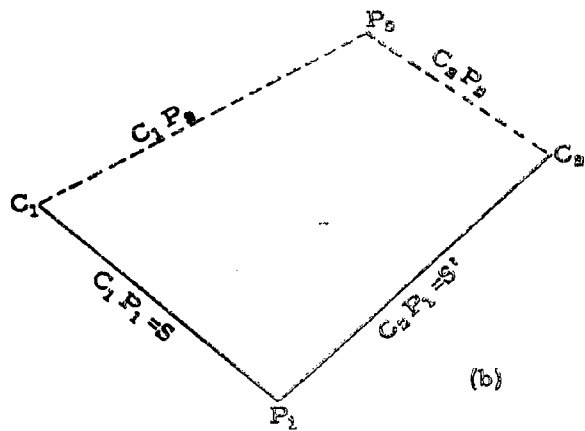
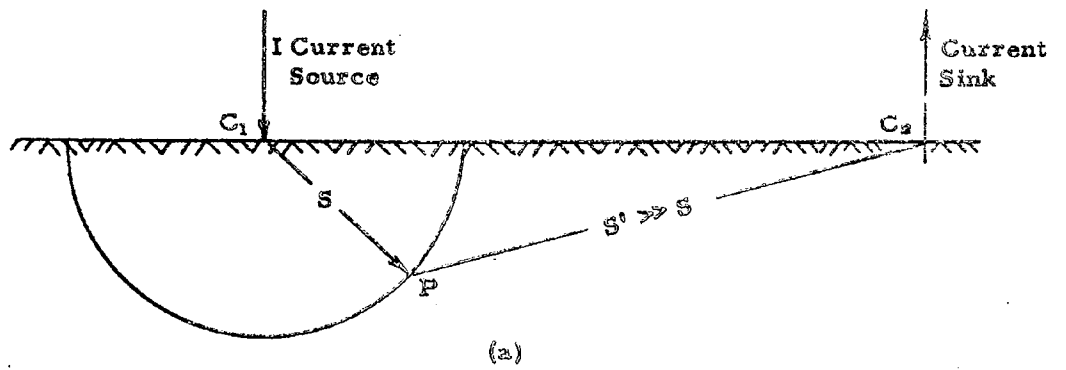

Figure 37. FOUR-POINT ARRAY.

from the Wenner array in that the current stakes are adjacent as are also the potential stakes. The arrangement is shown in Figure 39 and its configuration yields a current penetration which extends further into the earth than does the Wenner method. The Wenner method yields essentially a surface value of conductivity. For the Eltran array,

$$\sigma = \frac{1}{2\pi R_s} \left(\frac{1}{2a} + \frac{1}{2a} - \frac{1}{a} - \frac{1}{3a} \right) = \frac{1}{6\pi A_s R_s} \text{ mho-m/sq. m.} \quad 3(7)$$

or

$$\sigma = \frac{0.174}{A_{ft} R_s} \text{ mho-m/sq. m.} \quad 3(8)$$

Again, R_s is the ratio, $V_{P_1 P_2} / I$.

Wait Array. A modification of the Eltran array is that shown in Figure 40, known as the Wait array. In this latter array the current and potential circuits are arranged 90° to each other, thus minimizing the magnetic coupling between the current and potential circuits. For the Wait array,

$$\sigma = \frac{1}{2\pi R_s} \left(\frac{1}{2.414a} + \frac{1}{a} - \frac{1}{1.848a} - \frac{1}{1.848a} \right) = \frac{0.333}{2\pi a_s R_s} \text{ mho-m/sq. m.} \quad 3(9)$$

or

$$\sigma = \frac{0.1735}{A_{ft} R_s} \text{ mho-m/sq. m.} \quad 3(10)$$

The foregoing procedures apply when the earth's crust is composed of a homogeneous medium. A constant conductivity would be obtained for each type of array independent of stake spacing. However, if the earth's crust is not homogeneous the measured conductivity is not uniform for different stake spacings and an average conductivity is obtained for the particular depth of penetration. If the earth's crust were composed of two different conductivity layers, the surface layer of conductivity σ_1 having a depth d , and the underlying layer of conductivity σ_2 and the depth very great compared to d (theoretically infinite), Sunde¹⁰ has shown that the ratio of σ_1 to the apparent conductivity σ_a as given by the Wenner array (essentially a surface value) is:

$$\frac{\sigma_1}{\sigma_a} = 1 + 2 \sum_{n=1}^{\infty} \frac{k^n}{\sqrt{1 + \frac{2nd}{a}}} \quad 3(11)$$

¹⁰ Earth Conductivity Effects in Transmission Systems, by Erling D. Sunde, D. Van Nostrand Co., Inc., p. 51.

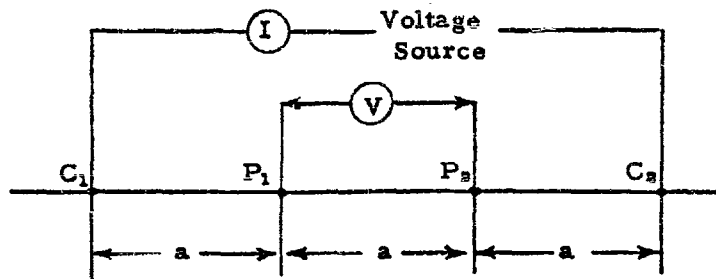

Figure 38. WENNER ARRAY.

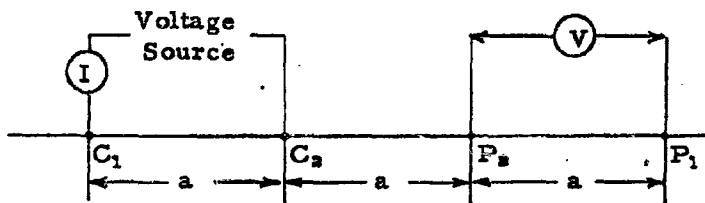

Figure 39. ELTRAN ARRAY.

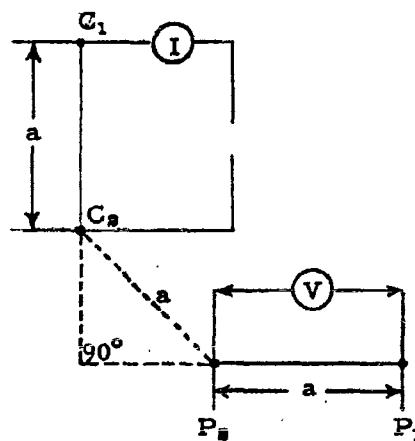

Figure 40. WAIT ARRAY.

where $k = \frac{\sigma_1 - \sigma_2}{\sigma_1 + \sigma_2}$ may be positive or negative, and depth d and spacing a are in the same units.

Example of two-layer stratification:

Suppose the ratio of surface conductivity, to the sub-strata conductivity, $\sigma_1/\sigma_2 = 10/1$.

Consider the case where the ratio of stakes spacing to surface layer depth is $a/d = 5/1$. Then:

$$k = \frac{9}{11}$$

and

$$\begin{aligned} \frac{\sigma_1}{\sigma_2} &= 1 + 2 \left[\frac{9/11}{\sqrt{1 + (\frac{2}{5})^2}} + \frac{(9/11)^2}{\sqrt{1 + (\frac{4}{5})^2}} + \frac{(9/11)^3}{\sqrt{1 + (\frac{6}{5})^2}} + \frac{(9/11)^4}{\sqrt{1 + (\frac{8}{5})^2}} + \dots \right] \\ &= 1 + 2 (0.760 + 0.522 + 0.352 + 0.286 + \dots) \\ &\rightarrow 9.1 \end{aligned}$$

The apparent conductivity is the $\sigma_a = \frac{\sigma_1}{9.1}$ mho-m/sq. m.

Suppose, now, the ratio of stake spacing to surface layer depth were to become 50/1. Then σ_1/σ_a would approach the value 10 and

$$\sigma_a = \frac{\sigma_1}{10}$$

or σ_a becomes the value σ_2 , that is, the apparent conductivity becomes equal to the actual conductivity of the sub-strata layer.

Measurement of Ground Conductivity Utilizing the Effects of a Radiated Wave.

The foregoing methods for measuring ground conductivity are especially applicable when one wishes to determine the conductivity in a precise area such as for grounding a tower, a building or any large structure or system. If, however, the average conductivity over a great circle radiation path is desired then a procedure which utilizes theoretical

ground wave field strength curves may be more applicable. Theoretical ground (or surface) wave curves which show the relationship between ground wave field strength in millivolts per meter and distance from the antenna in miles for values of conductivity ranging from 0.5 to 40 millivolts-meter/square meter (5000 for sea water) and for ϵ_r of 15 have been plotted for frequencies from 0.54 to 1.64 Mc in the FCC regulations¹¹.

In using these curves, the procedure is to make field strength measurements from 1 to about $50/f_{mc}^{1/3}$ miles, provided it is known that ϵ_r for the subject ground is 15, and then plot these data vs. distance in miles on the same type of log-log paper as is used in the plots appearing in the FCC regulations.¹² The sheet containing the plotted test data is then placed over the theoretical set of curves corresponding to the frequency under consideration. Keeping the axes properly aligned, the test data sheet is manipulated vertically and horizontally until the test curve has a "best fit" with one of the theoretical curves. The value of σ is then obtained from the labeling on the theoretical curve.

If the value of ϵ_r does not correspond to the value 15 then the FCC curve appearing on Page 89 of the Regulations may be used. This latter curve is a plot of relative field strength versus "numerical distance, p "¹³ for various values of the parameter b^0 . To use this curve, superimpose the sheet having the plotted test data over the curve appearing in the FCC regulations. Again, with the axes properly aligned, shift the test curve sheet horizontally and vertically until a "best fit" is obtained. With the two sheets holding this position, read p from the abscissa of the theoretical curve directly under the $d=1$ abscissa point of the test curve. Read also the value of b^0 from the theoretical curves which match with the test curve.

Now knowing the value of $p_{(d=1)}$ (the numerical distance at 1 mile) and b^0 , the conductivity and dielectric constant may be obtained from the following expression:

$$X = \frac{\pi}{p} \frac{d}{\lambda_1} \cos b \text{ (for vertical polarization)} \quad 3(12)$$

$$X = \frac{p}{\pi} \frac{\lambda}{d_1} \cos b_1 \text{ (for horizontal polarization)} \quad 3(13)$$

¹¹ FCC Rules and Regulations, Vol. III, pp. 49-87.

¹² Such as K + E Logarithmic, 359-128L, 7 x 4 cycles.

¹³ Ultra-High Frequency Propagation, by Reed and Russell, John Wiley & Sons, Inc., New York. pp. 156-160.

where $b^1 = 180 - b$, and

$\frac{d}{\lambda_1}$ is number of wavelengths in 1 mile

Then

$$\sigma = \frac{XEM_0}{18,000} \text{ mho-m/sq. m.} \quad 3(14)$$

and

$$\epsilon_r = X \tan b - 1 \text{ (for vertical polarization)} \quad 3(15)$$

$$\epsilon_r = X \tan b + 1 \text{ (for horizontal polarization)} \quad 3(16)$$

The accuracy with which one can read the value of b° from the theoretical curve determines the accuracy of ϵ_r and, at best, it is difficult to obtain a true reading of b° .

3.1.7 Design of Grounding System Utilizing Ground Grid Mesh

3.1.7.1 Method for Determining Optimum Dimensions of Earth Ground Grid Mesh

Ground grid meshes are often required to compliment rod beds or to be used separately when deep-driven rods are impractical due to terrain considerations. The following formula can be used to calculate the ground resistance of a earth ground grid mesh:¹⁴

$$R = \frac{\rho}{\pi L} \left(\log_e \frac{2L}{a^1} + k_1 \frac{L}{\sqrt{A}} - k_2 \right) \text{ (ohms)} \quad 3(17)$$

where:

ρ = soil resistivity, ohm-centimeters

L = total length of all connected conductors (centimeters)

a^1 = $a \times 2z$ for conductors buried at a depth of z cm, or

a^1 = a for conductors on earth surface

$2a$ = diameter of conductors, (cm)

A = area covered by conductors, (cm^2)

k_1, k_2 = coefficients

A derivation of the above expression is included in Appendix I of this report.

¹⁴ Analytical Expressions for Grounding System Resistance, by S.J. Schwarz, Transaction of AIEE, August, 1954.

The coefficient k_1 is the same as that used in Equation 3(2) in Section 3.1.2. Coefficients, k_2 , have been calculated for loops encircling areas of the same shape and depth as used for calculating k_1 . Calculated results are shown in Figure 41.

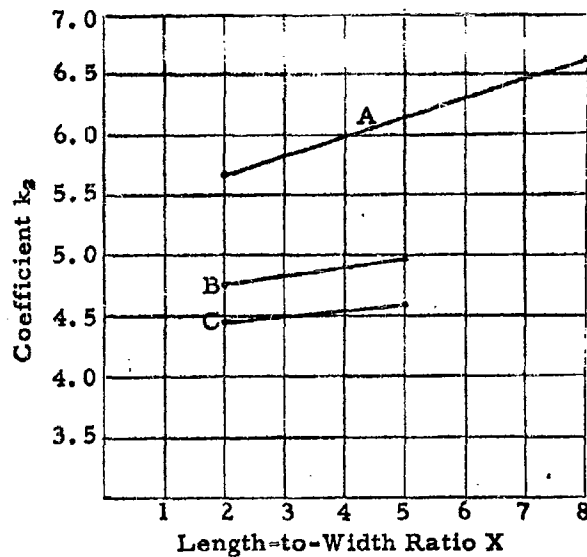

Figure 41. VALUES OF COEFFICIENT k_2 CORRESPONDING TO COEFFICIENT k_1

Equation 3(17) has been slightly simplified for purposes of data calculation as indicated in the following formula:

$$R = \frac{1.045\rho}{L} \left(\log_e \frac{2L}{a} + k_1 \frac{L}{\sqrt{A}} - k_2 \right) \quad 3(18)$$

where

$$a = \sqrt{\frac{1}{12}} \text{ conductor diameter (in.) } \times \text{ depth (ft.)}$$

L = rod length (ft.)

ρ = soil resistivity (ohm-meter)

(remaining factors are equivalent to those of Equation 3(17))

Resistance has been calculated as a function of foundation or area of grid coverage and number of grids per side using 4/0 copper cable. The resistivity of the earth was assumed as 50 ohm-meters for calculation purposes. Coefficients k_1 and k_2 vary only slightly with area and the error introduced by using calculated data for both square and rectangular grids is negligible. Calculated data is presented graphically in Figure 42.

Grounding resistance afforded by buried grid meshes can be reduced most significantly by increasing the number of grids and by increasing the area of grid coverage. Data has been extrapolated from Figure 42 and re-plotted in Figure 43 to show ground resistance as a function of area of grid mesh coverage and single and optimum number of grids per side.

Various factors are illustrated by such graphical illustrations worthy of consideration in developing optimum design criteria for earth grid meshes: (1) a far greater reduction in ground resistance is realized by using increased areas of grid coverage up to approximately 90,000 ft.², (2) beyond 90,000 ft.², maximum ground resistance reduction is realized by optimum usage of number of grids and (3) the average optimum reduction of ground resistance resulting from additional grids is approximately 0.2 ohms.

This section presents example problems which are intended to illustrate methods by which Figures 42 and 43 may be used in designing earth ground grid meshes. This section shall be applicable to all buildings or structures requiring ground grid meshes in lieu of ground rods due to terrain considerations or other unforeseen factors.

Example 1. PROBLEM: An earth ground grid mesh is to be installed under a building to be located in an area that is not prone to severe climatic fluctuations. The foundation area of the structure is to be approximately 50 foot square (2500 ft.²). A grounding resistance of approximately one (1) ohm is required due to the intended usage of the building. Measurements indicate that a soil resistivity of 50 ohm-meters exists at a depth of three (3) feet below the earth's surface, and rocky soil precludes measurements at greater depths.

ANSWER: As in previous discussions, a ground resistance tolerance of approximately 50% should be allowed in design procedures to account for possible fluctuations in earth resistivity and bond impedance due to age and wear. Therefore, the design resistance should be approximately 0.5 ohms. Since the value of soil resistivity is the same as that used for calculating data for Figures 42 and 43, graphical

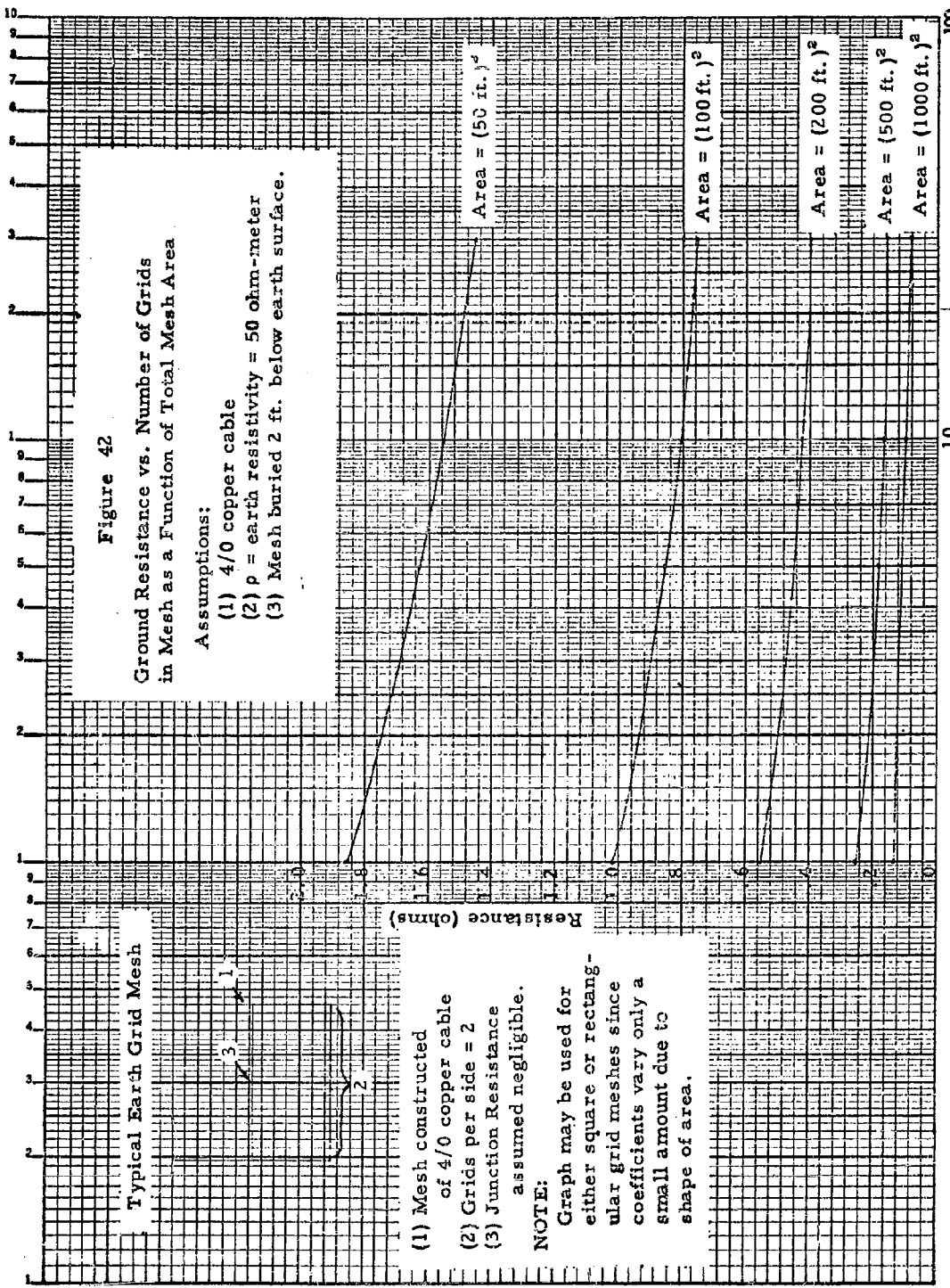

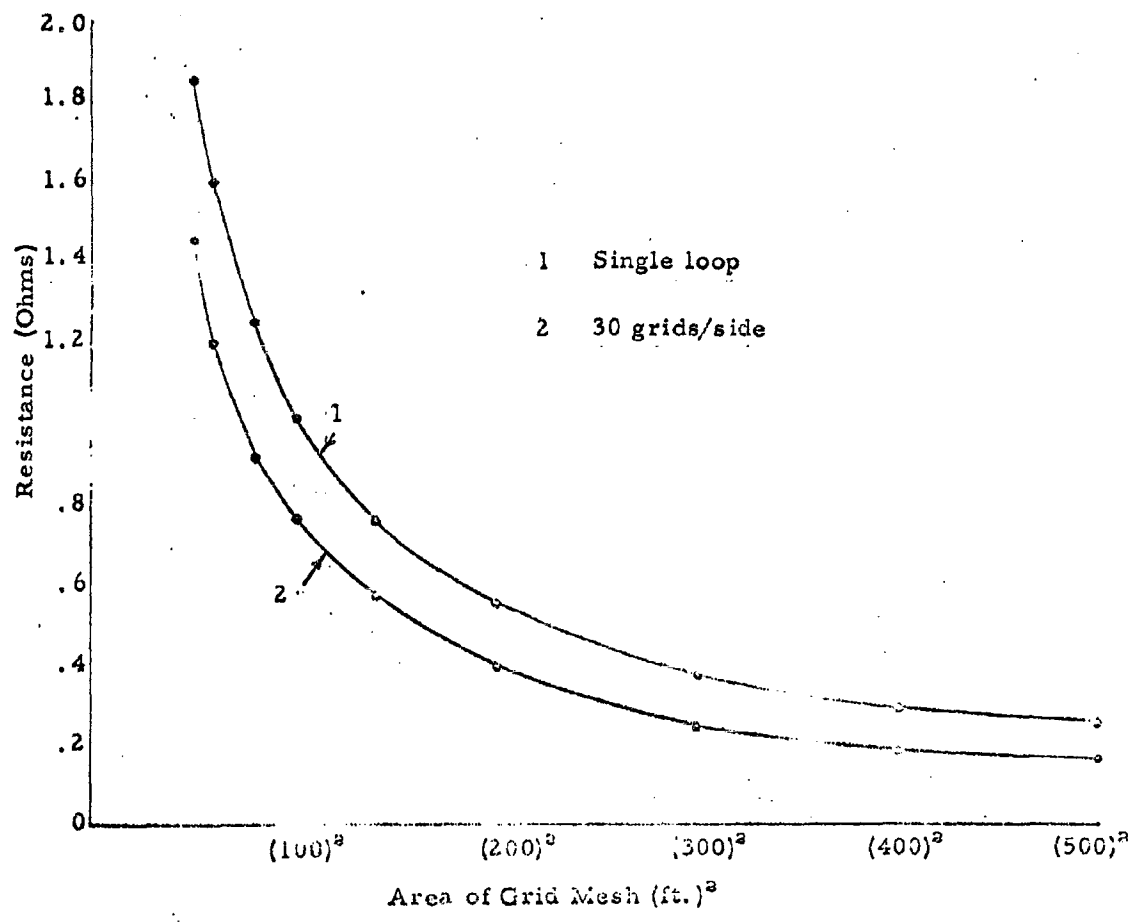

Figure 43-Ground Resistance vs. Grid Mesh Area

values may be used directly. Figure 43 indicates that the required grounding resistance cannot be realized using an optimum number of meshes over an area of 2500 ft.² or even 10,000 ft.². An area of coverage of approximately (175 feet)² using approximately ten (10) grids per side will yield the required grounding resistance. Figure 42 indicates that an increased area of coverage or grids per side beyond these amounts will yield a relatively small reduction in ground resistance. It is therefore recommended that 4/0 copper cable be used to construct a grid mesh 175 foot square having 10 grids per side and buried 3 feet below the surface of the earth. In lieu of the above recommendations, the earth may be artificially treated to reduce the value of soil resistivity and the required area of coverage will be reduced considerably.

Example 2. PROBLEM: A space vehicle checkout complex is to be installed in an area where terrain considerations preclude the usage of deep driven ground rods. The foundation dimensions are to be 100 ft. by 500 ft. or 50,000 ft.². Ground resistance must be as low as practically feasible without regard to incurred expense and shall in no case exceed 0.5 ohms. Measurements indicate an average soil resistivity of 25 ohm-meters at a depth of two (2) feet below the surface of the earth. Moisture content of the soil may be expected to fluctuate somewhat due to climatic variations.

ANSWER: The intended usage of the building, elimination of ground rods as a source of ground and the expected fluctuations in soil moisture content, make problems such as this extremely difficult to solve. The approach shall be to use the data of Figures 42 and 43 for designing the grid mesh and require periodic measurements of ground resistance to observe and remedy resultant fluctuations.

As in previous examples a ground resistance tolerance of approximately 50% should be allowed in the initial design. Therefore, the design resistance should be approximately 0.25 ohms. Since the soil resistivity (25 ohm-meters) is 1/2 the value used for calculating data for Figures 42 and 43, indicated values of resistance are twice their true value in this case. Therefore 0.5 ohms in Figure 42 will be equal to 0.25 ohms. The required resistance can be obtained using an area of coverage approximately 40,000 ft.² with two or more grids per side. However, due to the intended building usage, ground resistance is to be reduced as much as practically feasible. Figure indicates that beyond 90,000 ft.² and 30 grids per side, very little reduction in ground resistance is available. These factors would yield a ground resistance of approximately 0.12 ohms.

It is recommended that the grid coverage be 90,000 ft.² (150 x 600 ft.) and that no less than 30 grids per side be implemented. The grid should be constructed of 4/0 or solid copper cable of 1/4 inch in diameter

or greater. The grid should be buried to a depth of no less than two feet and preferably three feet if possible. Periodic inspections should be performed to insure that the ground resistance does not exceed the required maximum of 0.5 ohms.

3.1.8 Method for Connecting Earth Ground Grid Mesh to Structure.

Figure 44 illustrates a preferred technique for connecting an earth ground grid mesh to a structure. The end of the bond cable should be tinned where connection is made with the structure's base shoe in order to reduce effects of galvanic corrosion. A double connection is made between the bond cable and the grid mesh to reduce the possibility of bond deterioration with age and wear. All connections should, preferably, be wrapped, welded and covered with a protective coating, as indicated. All structure base shoes should be connected in a like manner to the grid mesh. Techniques illustrated in Figure 27 of Section 3.1.4 should be adhered to when grid meshes are used in conjunction with ground rods.

3.1.9 Method for Approximating Combined Ground Resistance of Mesh and Ground Rods.

In many cases it may be necessary to use a combination of ground rods and a grid mesh below ground to obtain a sufficiently low ground resistance. Figure 45 illustrates how a combination of a grid mesh and ground rods might be physically implemented. The mutual resistance between the two grounding systems can be approximated by the following equation¹⁵:

$$R_{12} = R_{21} = \frac{\rho}{\pi L} \left(\log_e \frac{2L}{L_1} + k_1 \frac{L}{\sqrt{A}} - k_2 + 1 \right) \text{ (ohms)} \quad 3(19)$$

where:

$R_{12} = R_{21}$ = mutual resistance of both systems and remaining parameters are equivalent to those used in formulas for rod and mesh resistance presented in Sections 3.1.2 and 3.1.7.

The combined rod bed and grid resistance can be expressed as follows:¹⁵

$$R = \frac{R_{11}R_{22} - R_{12}^2}{R_{11} + R_{22} - 2R_{12}} \quad 3(20)$$

¹⁵ "Analytical Expressions for the Resistance of Grounding Systems", by S.J. Schwarz, Proceedings of AIEE, August, 1954.

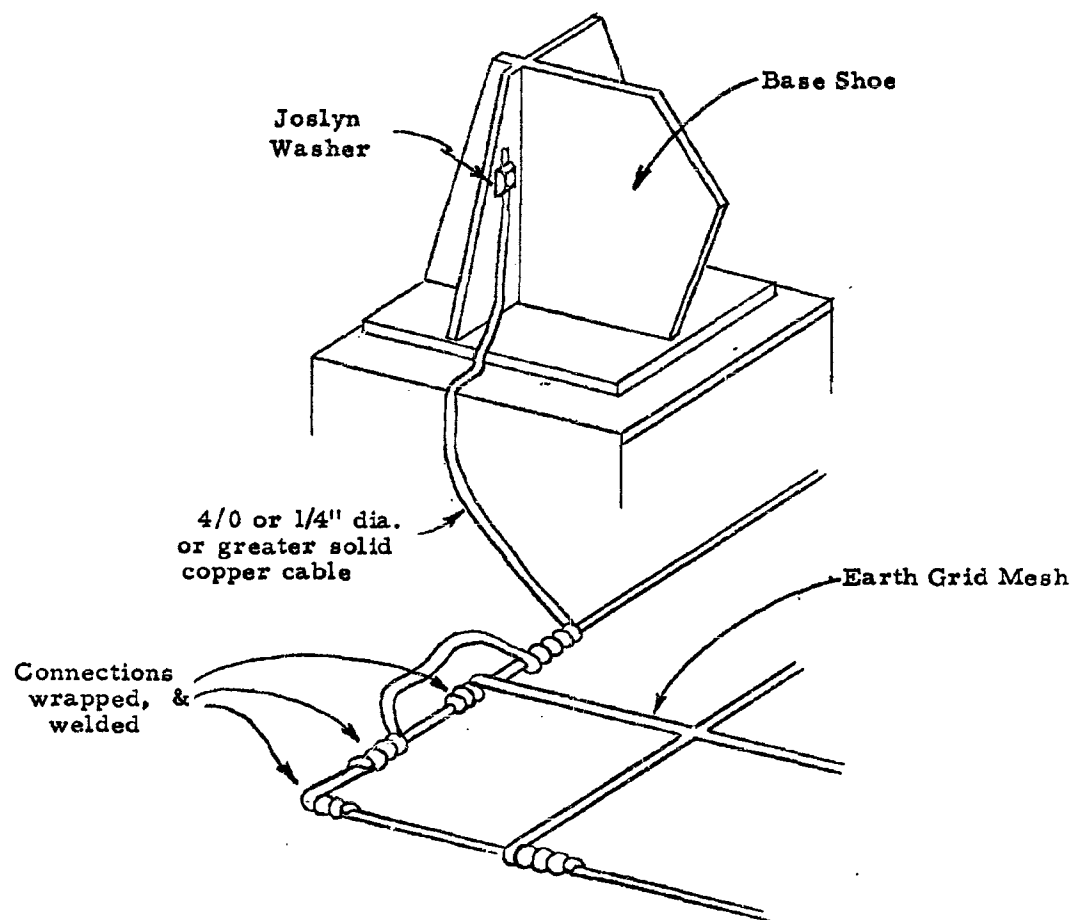

Figure 44. METHOD FOR CONNECTING EARTH GROUND GRID MESH TO STRUCTURE.

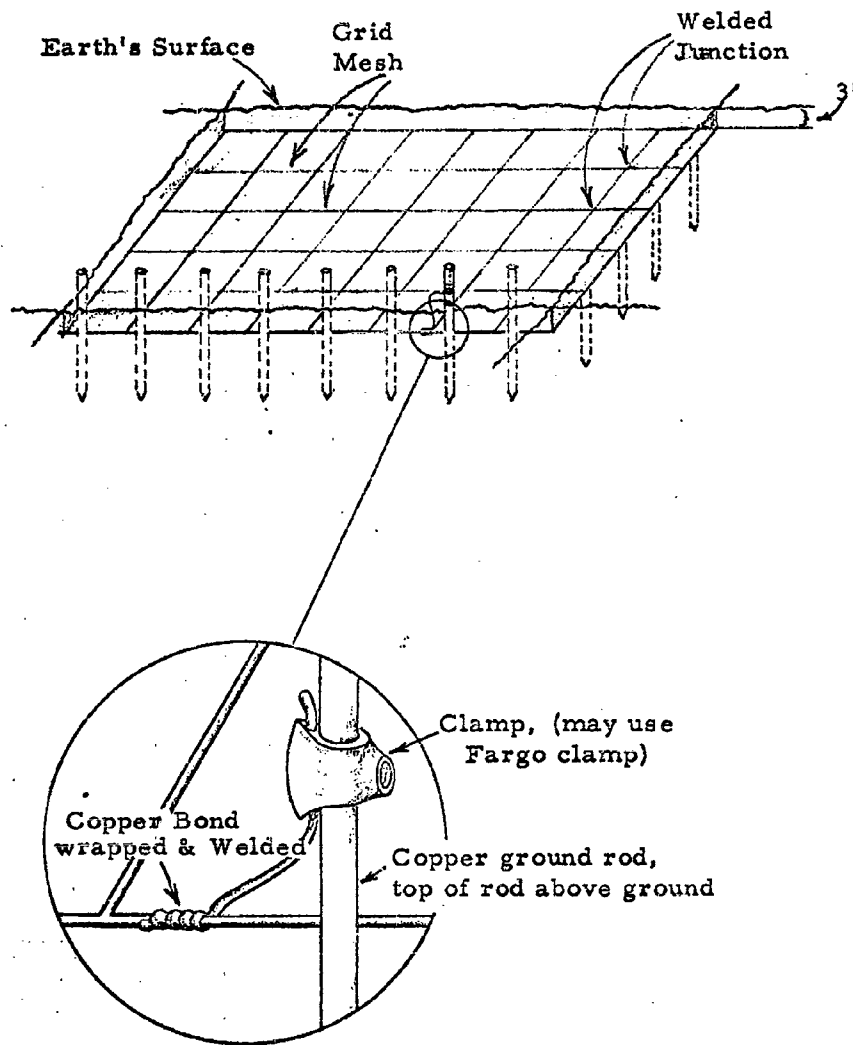

Figure 45. TYPICAL COMBINATION OF GROUND RODS AND GRID MESH.

where:

- R_{11} = resistance of grid alone as presented in Section 3.1.7
- R_{22} = resistance of rodbed alone as presented in Section 3.1.2
- R_{12} = mutual resistance between systems
- R = combined resistance.

The reduction in ground resistance achieved by adding rods to a grid will hardly warrant the extra cost. Yet there are points in favor of such an arrangement: (1) insure practically constant ground resistance where soil resistivity may fluctuate near the earth's surface due to extreme climatic conditions, or (2) rods used to provide a reliable ground source and grid used as a safety measure to equalize fault potentials over the earth's surface.

3.2 Reference Plane Ground Grid.

BUILDINGS REQUIRING LOW IMPEDANCE REFERENCE PLANE GROUND MESHES.

All buildings or complexes housing electronic equipments which are susceptible to or capable of generating RF energy shall be supplied with a low impedance reference plane ground grid mesh.

REFERENCE PLANE GROUND GRID MESH.

All conductive shielding media used for the purpose of attenuating RF energy are dependent upon a low impedance reference plane for effective attenuation. Shields that are connected to a relatively high impedance reference plane are completely ineffective in attenuating RF electric fields and will, in fact, radiate electric field energy resulting from potentials induced on the reference plane by extraneous users of the reference plane. Earth ground is not essential to performance of this function, however, a single connection to earth is desired for protective purposes.

3.2.1 Determination of Optimum Physical Grid Dimensions as a Function of Impedance Requirements and Foundation Area.

Within the scope of this contract it would at first appear that design specifications for a low impedance reference plane ground grid mesh would be limited to construction design techniques necessary to preclude electromagnetic interference caused by structure in high RF fields. Using this philosophy the impedance requirements of the reference plane ground grid

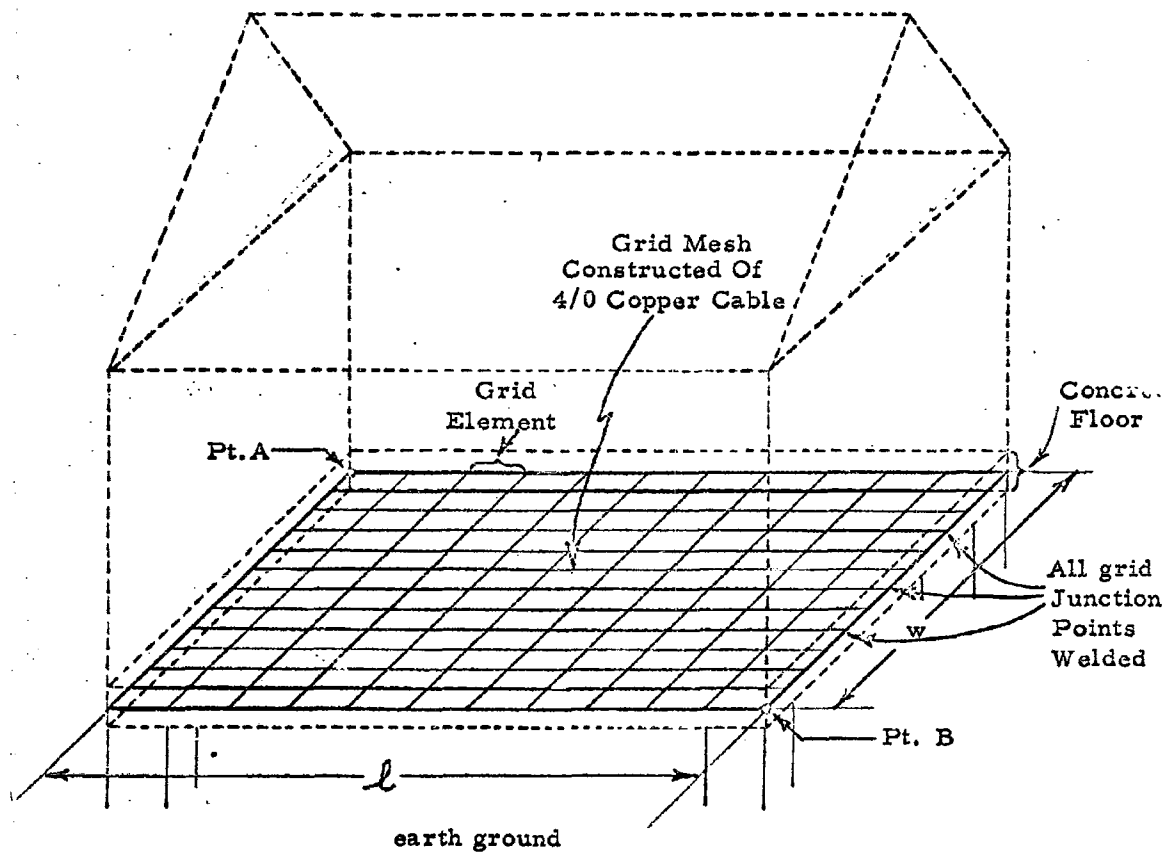

Figure 46. HYPOTHETICAL APPLICATION OF REFERENCE PLANE GRID MESH.

l = length of grid mesh or foundation
(11 grids per length)

w = width of grid mesh or foundation
(12 grids per width)

mesh would not be exceptionally low. However, since it is to be expected that a multitude of users will depend upon the reference plane, design criteria must be compatible with their requirements also. Extraneous users of the reference plane may be extremely susceptible to relatively small amplitudes of interference, and as a result of this requirement the following criteria shall be adhered to for design purposes of the reference plane ground grid mesh:

1. The low impedance reference plane ground grid mesh shall be designed to offer minimal impedance to current flow,
2. Impedance shall be reduced by utilizing wire size and number of grids to a point where further impedance reduction is not economically feasible for the percentage impedance reduction obtained relative to incurred expense.

The initial problem is to determine the number of grids, associated dimensions and wire size to be used in constructing a reference plane grid mesh to obtain an optimum reduction in resultant impedance. Figure 46 illustrates a hypothetical application of such a reference plane. The maximum impedance (resistance and self-inductance) offered to current flow by the grid mesh is encountered between points (A) and (B). The following paragraphs shall pertain to the development of expressions describing variations in impedance between points (A) and (B) as a function of various parameters.

For a prescribed length and width of a specific reference plane grid mesh the following two factors are working in opposing directions to change the resistance between points (A) and (B) (R_{AB}) as a result of changes in the number of grids per side: (1) as the number of grids is increased R_{AB} decreases due to the decreasing length of the grid elements and (2) as the number of grids is increased, R_{AB} increases due to the addition cables added to obtain the increased number of grids.

The following equation has been derived which expresses the maximum resistance offered by a square grid mesh (the derivation is included in Appendix III):

$$R_{AB}]_n = \frac{R_e]_{n-1}}{2n} \left[\frac{2k]_{n-1} [2(n-1)]}{1 + 2(n-1)} + 2 \right] \quad 3(21)$$

where

$R_{AB}]_n$ = resistance between points A & B for n grids per side (ohms)

n = number of grids per side

$R_e]_{n-1}$ = resistance of one element of total length equal to the length of one entire side of the grid (ohms)

k = multiplication factor to account for additional grids.

Figure 47

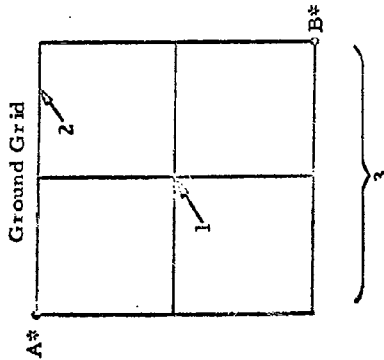
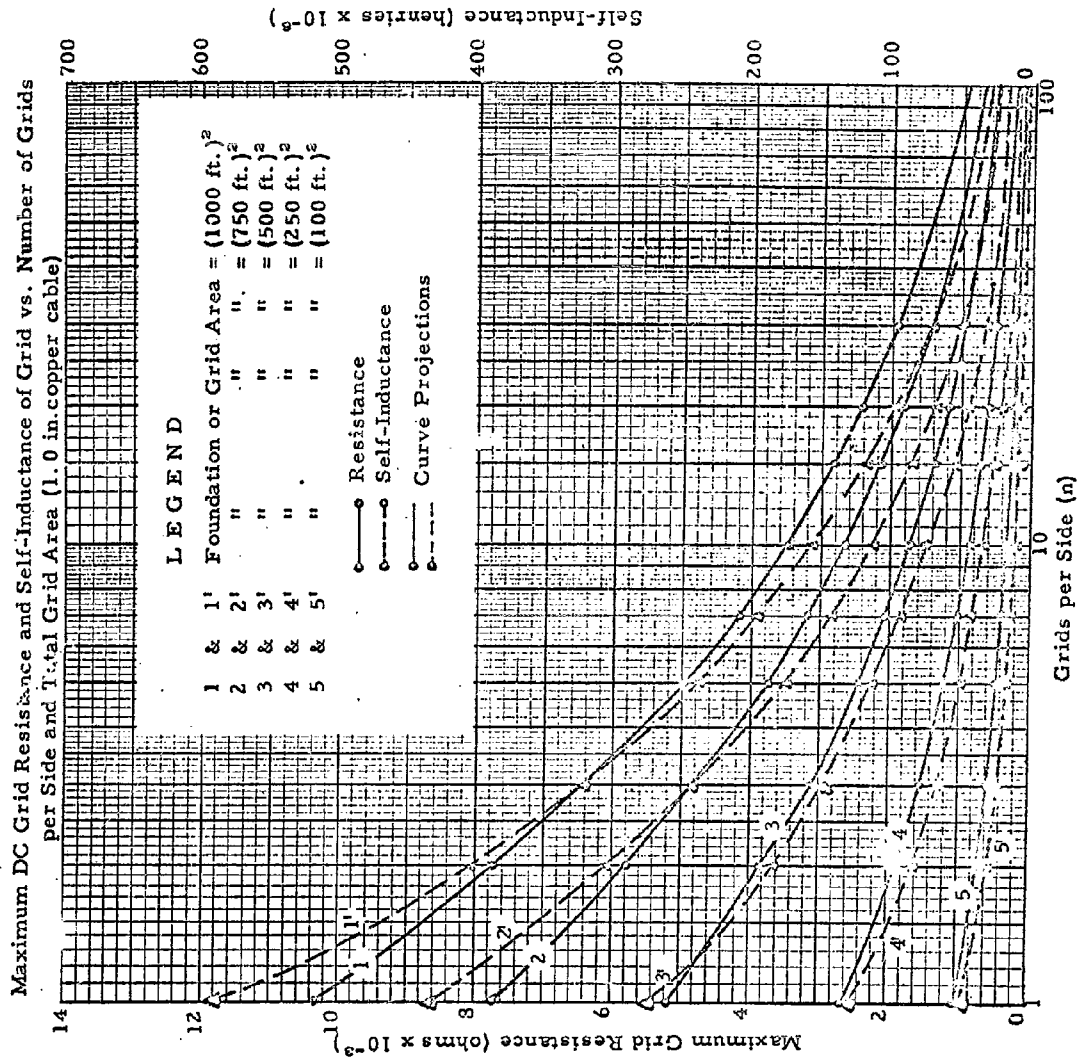

- 1 - Junction Impedance assumed negligible.
 - 2 - 1.0" copper cable.
 - 3 - Grids per side (n)=2.
- *Resistance & Inductance between points A & B.

Note:
Effects of mutual inductance neglected.

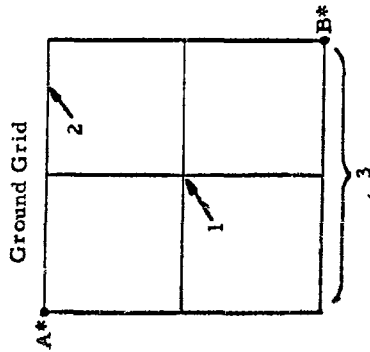

- 1 - Junction Impedance assumed negligible.
- 2 - 3/4" copper cable.
- 3 - Grids per side (n)=2
- * Resistance & Inductance between points A & B.

Note:
Effects of mutual inductance neglected.

Figure 48
Maximum DC Grid Resistance and Self-Inductance of Grid vs. Number of Grids per Side and Total Grid Area (3/4 in. copper cable)

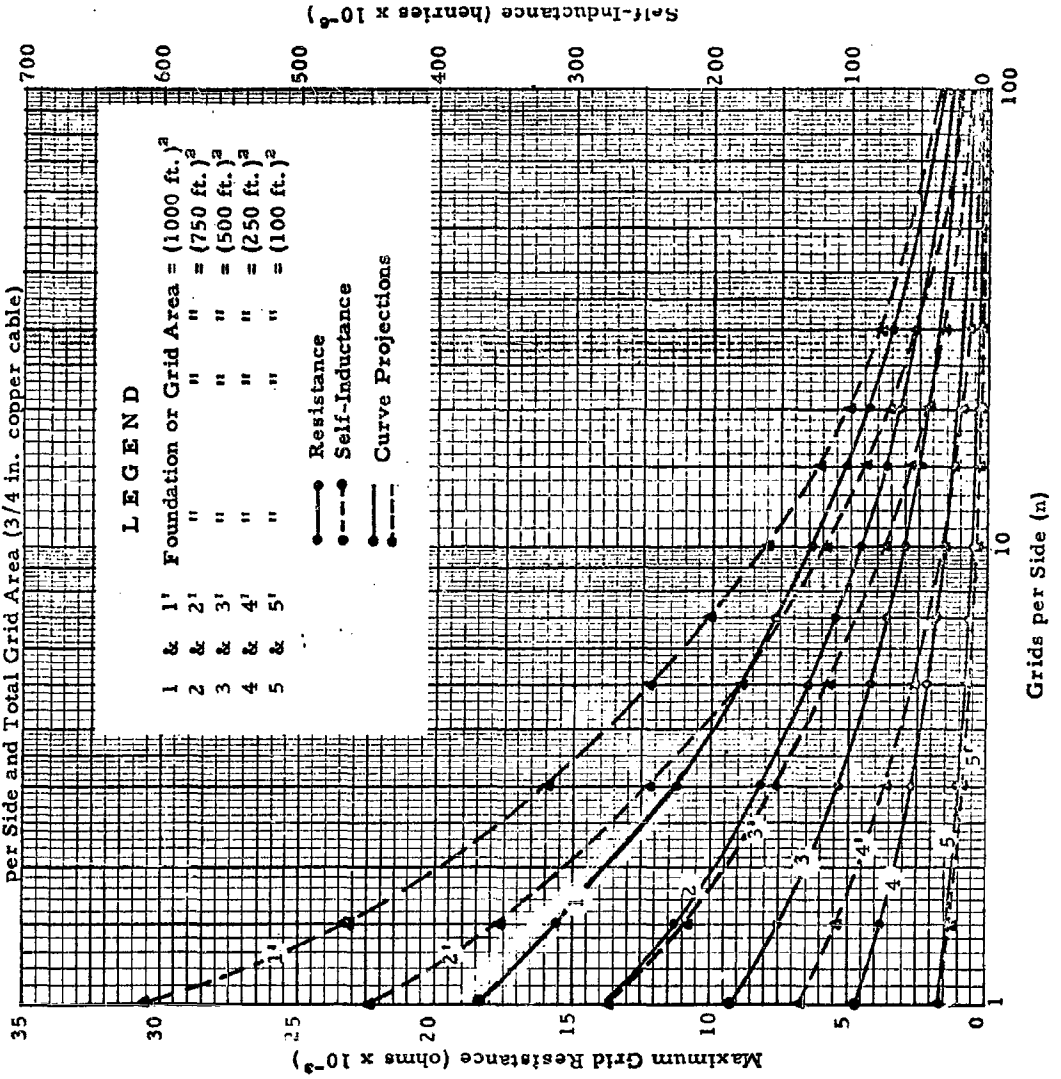
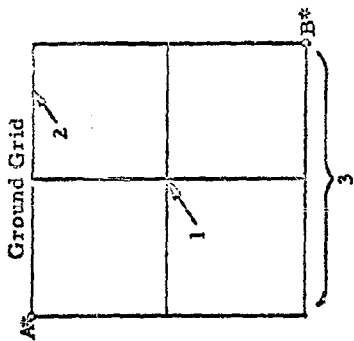
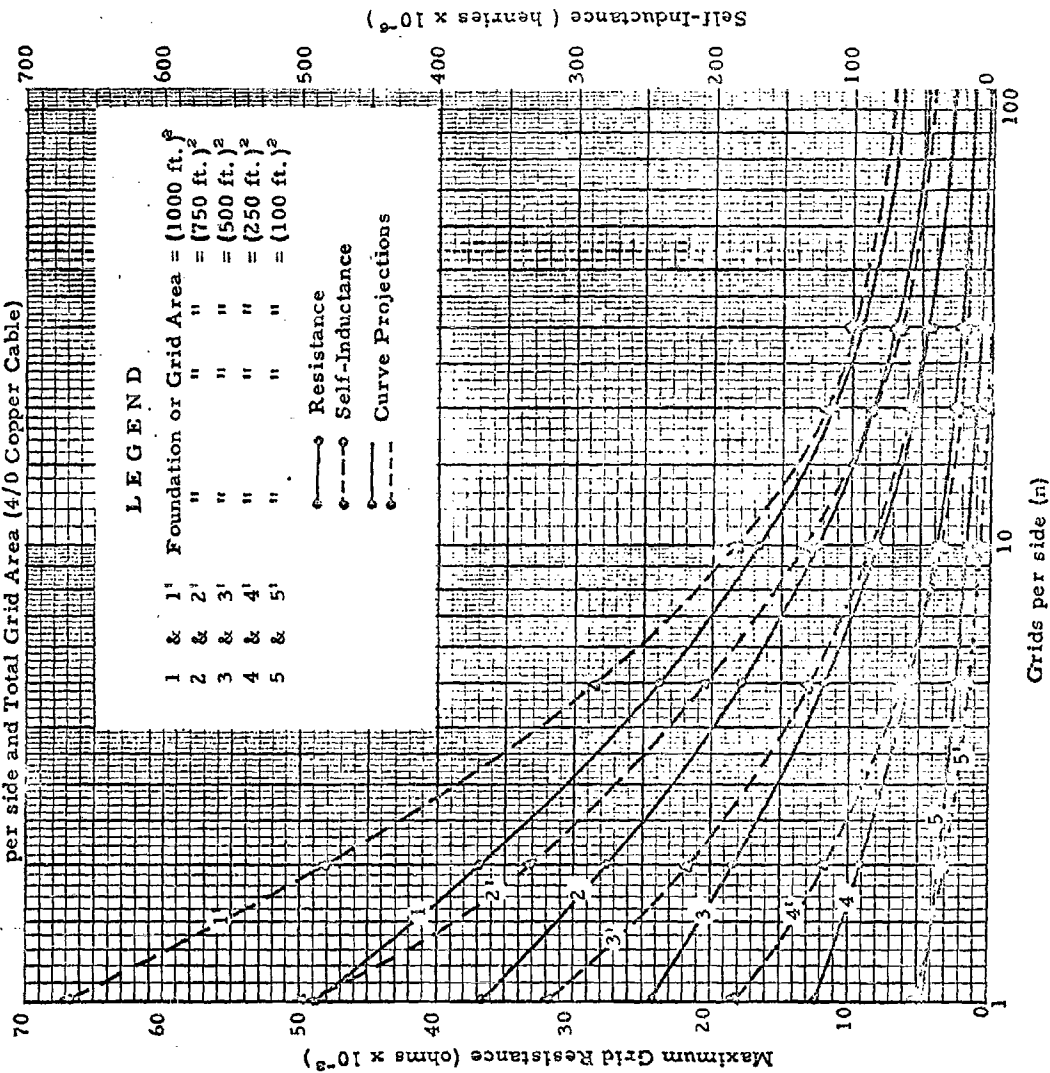

Figure 49
Maximum DC Grid Resistance and Self-Inductance of Grid vs. Number of Grids per side and Total Grid Area (4/0 Copper Cable)



- 1 - Junction Impedance assumed negligible.
 - 2 - 4/0 Copper Cable.
 - 3 - Grids per side (n)=2.
- * Resistance & Inductance between points A & B.

Note:
Effects of mutual inductance neglected.

The resistance of one element of total length equal to the length of one entire side of the grid (R_n) can be calculated by the following formula:

$$R_n = \rho \frac{\ell}{A} \quad 3(22)$$

where

ρ = resistivity of conducting media $\frac{\text{ohms}}{\text{circular mil foot}}$
 ℓ = length of conductor (ft.)
 A = cross-sectional area of conductor (circular mils)

Equation 3(21) is a recursion type formula and can only be used by calculating R_{AB} progressively from $n=1$ to $n=n$. R_{AB} has been calculated for values of n (grids per side) up to and including thirty (30). Such calculations have been performed for grid mesh areas of to (1000 ft.)² and for cable sizes of 1 inch, 3/4 inch, and 4/0. Resultant data is presented graphically in Figures 47, 48 and 49.

The distributed self-inductance of the grid mesh must also be considered for development of optimum design criteria. The high frequency self-inductance of copper cable can be approximated by the following formula:

$$L = 0.609 \ell \left(2.303 \log_{10} \frac{4\ell}{d} - 1 \right) \text{ (\muhenries)} \quad 3(23)$$

where

L = low frequency self-inductance (μ henries)
 ℓ = length of conductor (ft.)
 d = diameter of conductor (ft.)

The high frequency self-inductance of a copper grid mesh consisting of " n " grids per side can be computed using Equations 3(21) and 3(23) as follows:

$$L_{AB} = \frac{0.609 \ell \left(2.303 \log_{10} \frac{4\ell}{d} - 1 \right)}{2} \left[\frac{2k_{n-1} [2(n-1)]}{1 + 2(n-1)} + 2 \right] \text{ \muhenries} \quad 3(24)$$

or

$$L_{AB} = L_n k \text{ (\muhenries)} \quad 3(25)$$

where:

L_n = high frequency self-inductance of one element (See Figure 46) of the grid mesh.

$$= .0609 \ell (2.303 \log_{10} \frac{4\ell}{d} - 1) \mu\text{henries}$$

k = coefficient used in Equation 3(21) for various numbers of grids in the grid mesh.

$$= 1/2 \left(\frac{2k]_{n-1} [2(n-1)]}{1 + 2(n-1)} + 2 \right) \quad 3(26)$$

L_{AB} has been calculated for values of n (grids per side) up to and including thirty (30). Such calculations have been performed for grid mesh areas of (100 ft.)² to (1000 ft.)² and for cable sizes of 1 inch, 3/4 inch, and 4/0. Resultant data is graphically presented in Figures 47, 48, and 49 along with resistance data.

The maximum impedance offered by a rectangular grid mesh is different than the impedance offered by a square grid mesh with an equivalent number of mesh loops. The following expression has been derived which expressed the maximum resistance between points A and B of a rectangular grid mesh:

$$R_{AB}]_{n_w}^{18} = \frac{R_{e_w}]_{n=1}}{n_w} \left[k + k_n (n_L - n_w) \right] \quad (\text{ohms}) \quad 3(27)$$

where

$R_{AB}]_{n_w}$ = Resistance of rectangular grid mesh between points A and B (ohms).

$R_{e_w}]_{n=1}$ = Resistance of a single conductor of length equal to the width of the grid mesh (ohms).

n_w = number of grids along the short side or width of the rectangular mesh.

k = coefficient computed for square grid meshes with various numbers of grids per side.

k_n = correction factor to account for lengths greater than widths using n_w grids.

n = number of grids along the long side or length of the grid mesh.

Equation 3(27) has been used to calculate the resistance of a rectangular grid mesh for length to width ratios of 2 and 3, and for 1 inch and 4/0

¹⁸ The derivation of the Equation for R_{AB} is presented in Appendix IV of this report.

cable as a function of foundation or grid mesh area and number of grids on the short side of the rectangular grid mesh. Resultant data is graphically presented in Figures 50, 51, 52 and 53. The self-inductance of corresponding grid meshes has been neglected since curves for square grid meshes indicate that optimum reduction of grid resistance will also result in an optimum reduction of self-inductance.

This section shall present various hypothetical problems and solutions to illustrate how Figures in Section 3.2.1 can be used for optimum design of reference plane ground grid meshes. Such problem solutions are applicable to all structures requiring the usage of reference plane grid meshes.

Example 1. PROBLEM: A reference plane grid mesh is to be implemented in a structure intended to house sensitive electronic equipment. Specifications require that the maximum resistance offered by such a mesh be no greater than 25 milliohms and that the self-inductance be minimal. The structure is to have a single floor of foundation dimensions 500 ft. by 500 ft., (500 ft.)². Determine the type of cable to be used and the optimum number of grids per side.

ANSWER: Since the foundation area is square-shaped, Figures 47, 48 and 49 shall be used for design criteria. The impedance of bonds associated with the grid mesh can be expected to increase somewhat with age and wear. Therefore, a tolerance of approximately 25% should be applied to specification requirements to allow for such changes. The resultant resistance requirement would be:

$$\begin{aligned} R &= 25 (1 - .25) \times 10^{-3} \text{ ohms} \\ R &= 18.75 \times 10^{-3} \text{ (ohms)} \\ &\approx 19 \times 10^{-3} \text{ (ohms)} \end{aligned}$$

This resistance can be realized in the following manner:

- (1) (From Figure 49) 4/0 copper cable, 2 grids per side
 $R = 19 \times 10^{-3} \text{ (ohms)}$
 $L = 22 \times 10^{-6} \text{ (henries)}$
- (2) (from Figure 48) 3/4 in. solid copper cable, 1 grid per side,
 $R = 9.2 \times 10^{-3} \text{ (ohms)}$
 $L = 13.5 \times 10^{-6} \text{ (henries)}$
- (3) (From Figure 47) 1" solid copper cable, 1 grid per side,
 $R = 5.2 \times 10^{-3} \text{ (ohms)}$
 $L = 5.4 \times 10^{-6} \text{ (henries)}$

Example Ground Grid Mesh

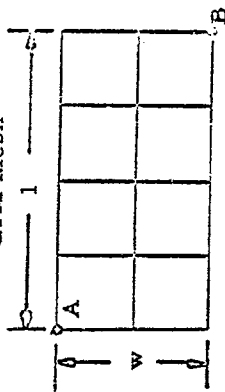

l/w = length to width ratio=2
 n_w = grids on short side=2
 R_{ab} = Resistance between points A & B.

Assumptions:

1. Resistance of grid junction points assumed negligible.
2. Each leg of grid mesh assumed equal in resistance.

Figure 50
 Plot of Maximum Resistance vs. Number of Grids on Short Side of Rectangular Ground Grid Mesh $l/w = 2$, 1" copper cable.

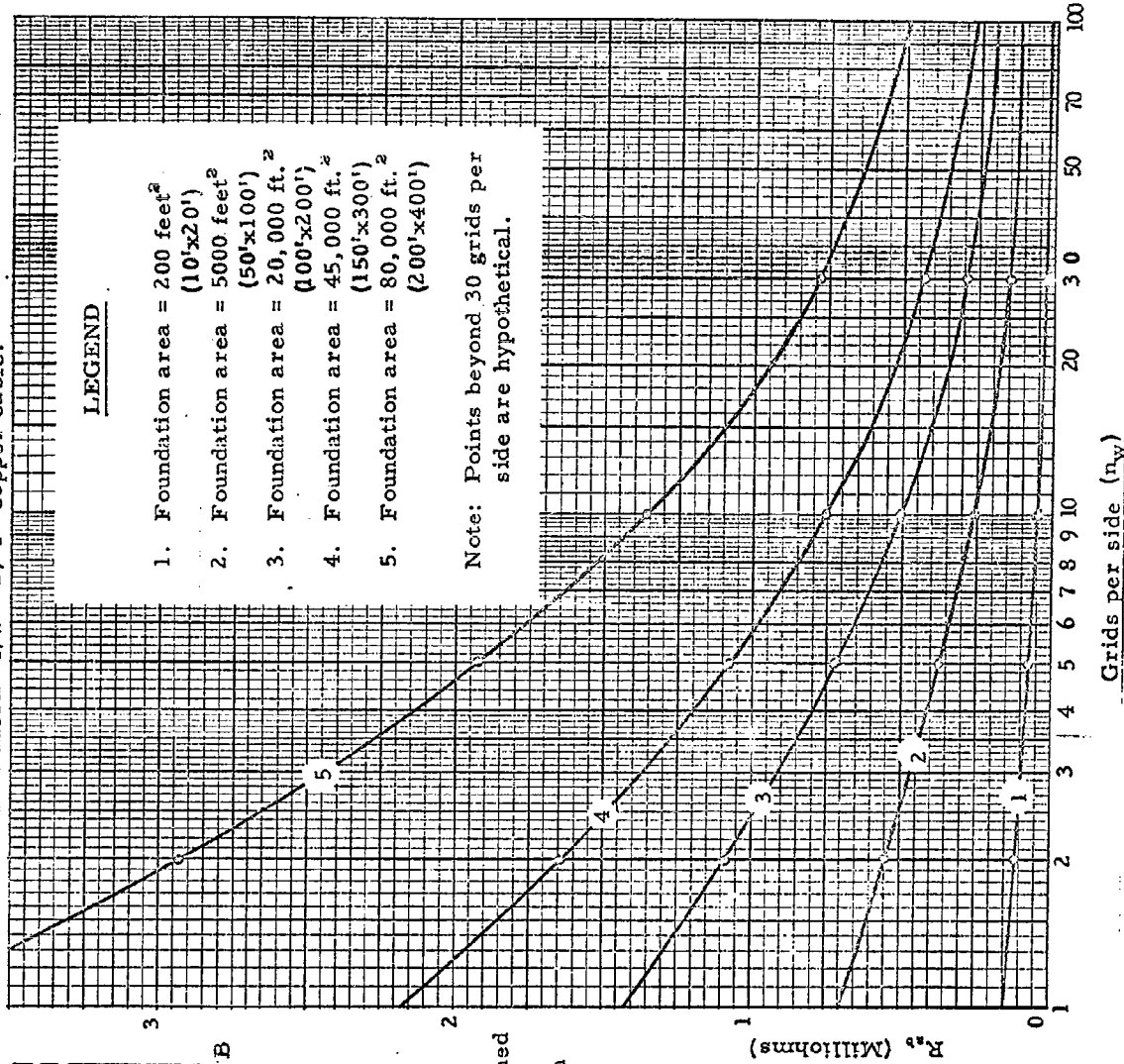

Example Ground Grid Mesh

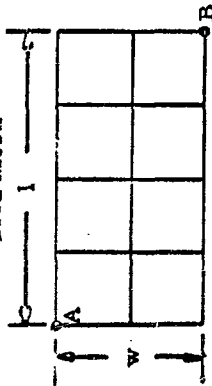

l/w = length to width ratio = 2
 n_s = grids on short side = 2
 R_{es} = Resistance between points A-B.

Assumptions:

1. Resistance of grid junction points assumed negligible.
2. Each leg of grid mesh assumed equal in resistance.

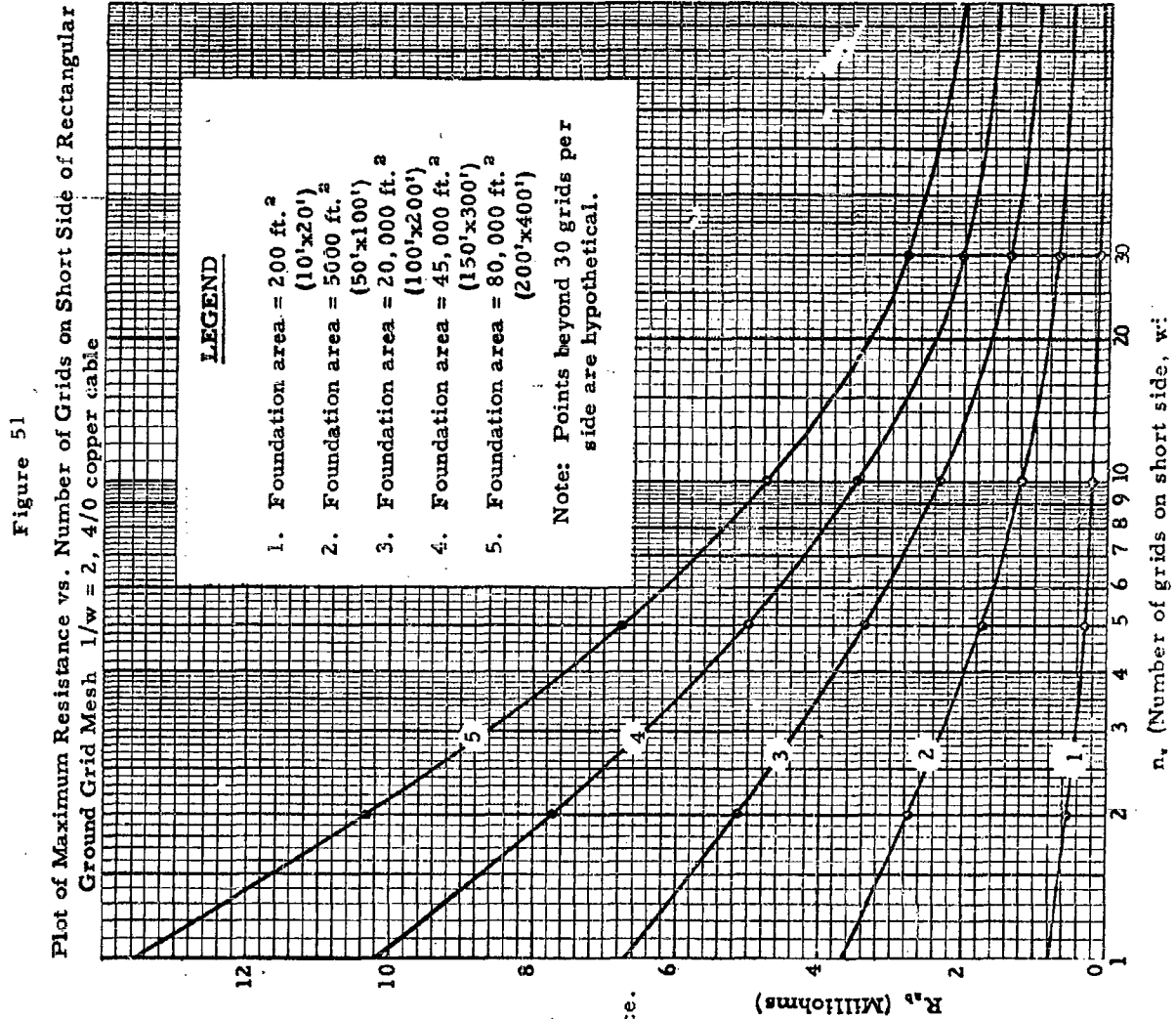

n_s (Number of grids on short side, w)

Figure 52
 Plot of Maximum Resistance vs. Number of Grids on Short Side of Rectangular
 Ground Grid Mesh. $l/w = 3$ 1" copper cable

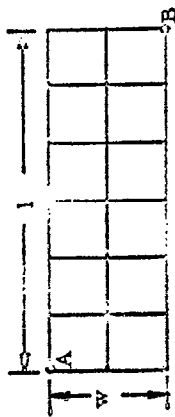
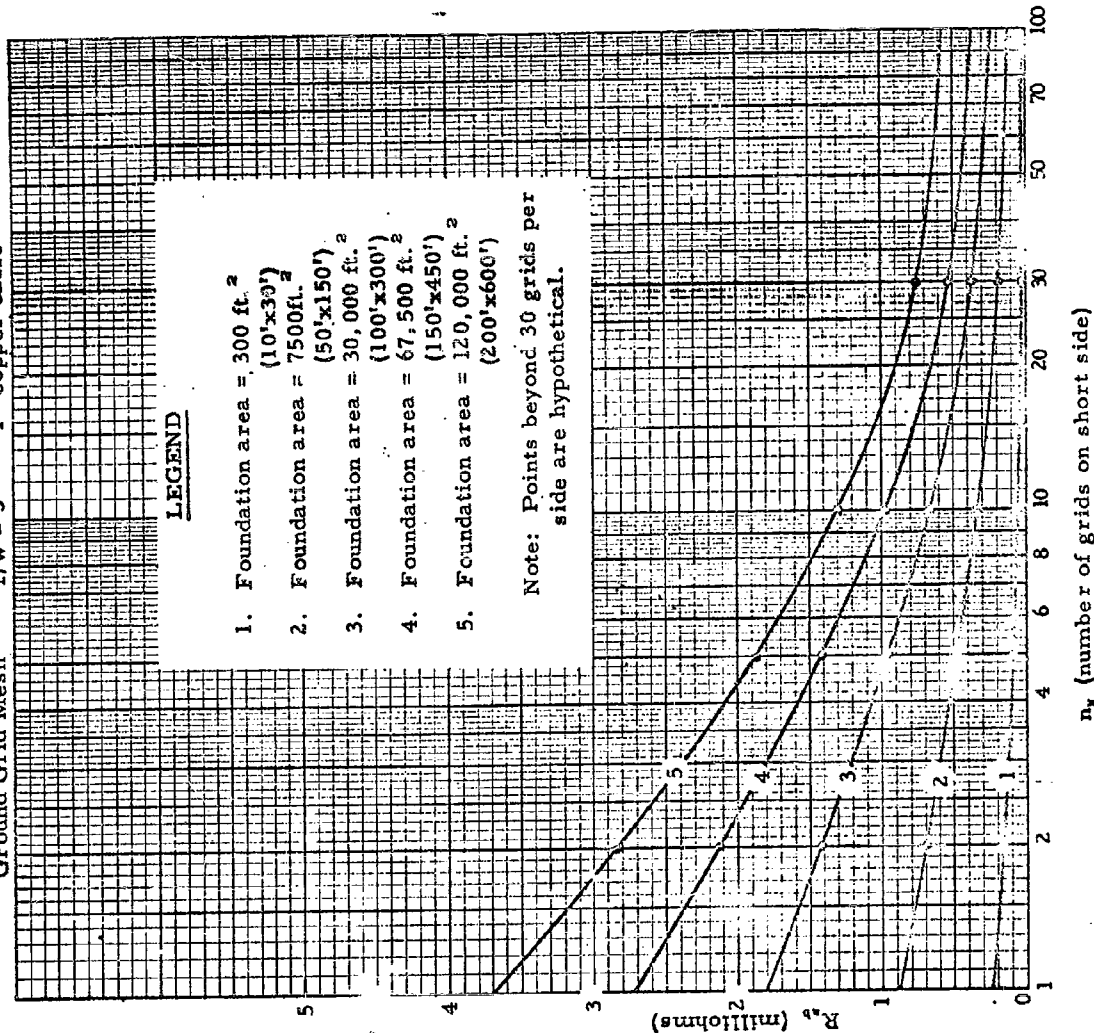

$l/w =$ length to width ratio
 $= 3$

$n_s =$ grids on short side
 $= 2$

$R_{AB} =$ Resistance between points,
 A & B.

Assumptions:

1. Resistance of grid junction points negligible.
2. Each leg of grid mesh assumed equal in resistance.

n_s (number of grids on short side)

Figure 53
 Plot of Maximum Resistance vs. Number of Grids on Short Side of Rectangular
 Ground Grid Mesh $l/w = 3$ 4/0 copper cable.

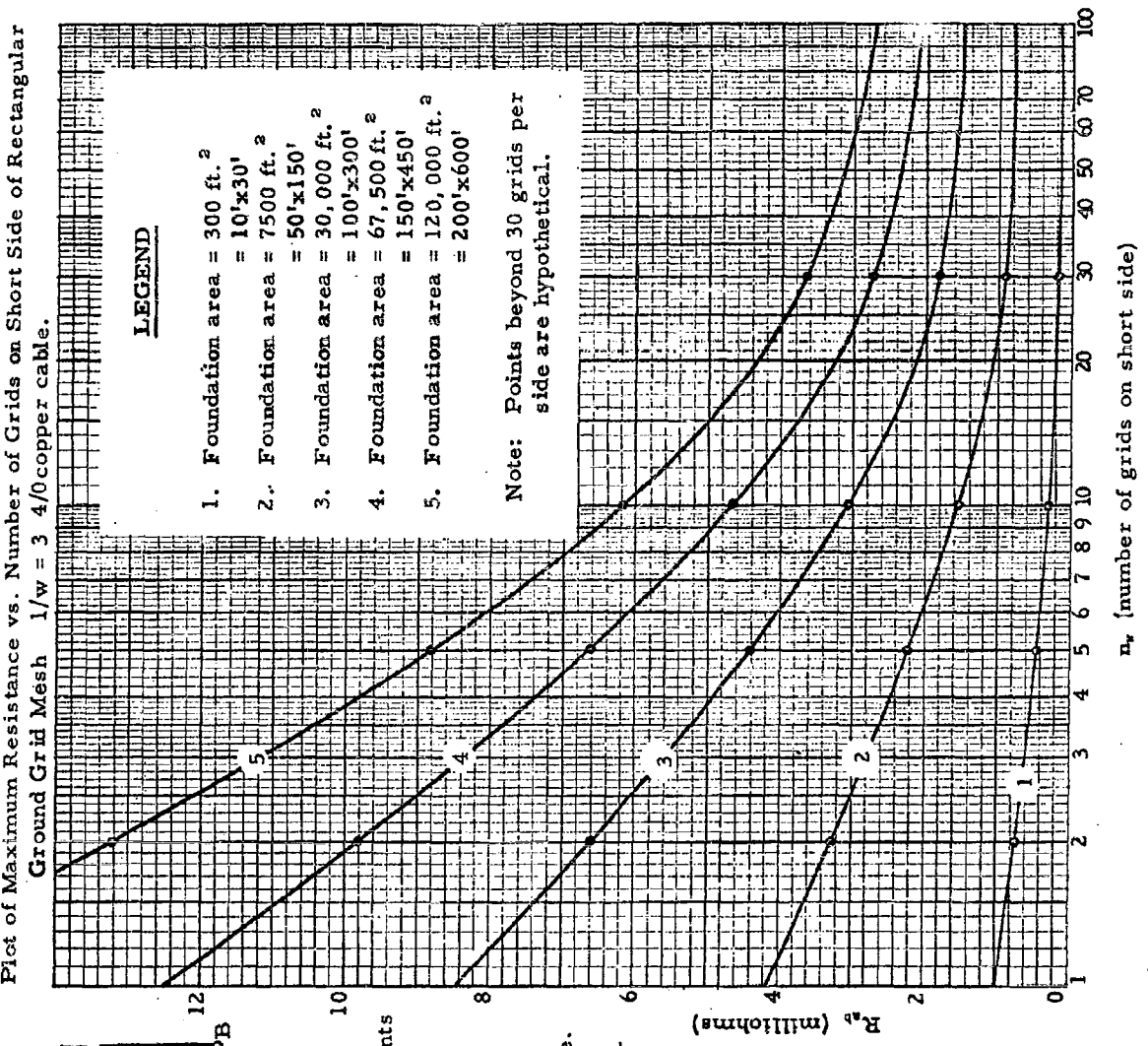

LEGEND

1. Foundation area = 300 ft.²
= 10'x30'
2. Foundation area = 7500 ft.²
= 50'x150'
3. Foundation area = 30,000 ft.²
= 100'x300'
4. Foundation area = 67,500 ft.²
= 150'x450'
5. Foundation area = 120,000 ft.²
= 200'x600'

Note: Points beyond 30 grids per side are hypothetical.

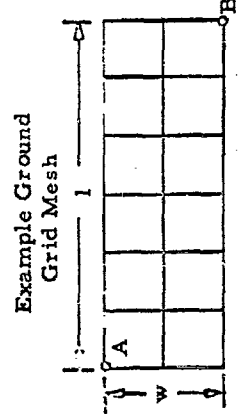

l/w = length to width ratio
 = 3
 n_s = grids on short side
 = 2
 R_{ab} = Resistance between points
 A & B.

Assumptions:

1. Resistance of grid junction points negligible.
2. Each leg of grid mesh assumed equal in resistance.

The grid area of coverage was maintained equal to the foundation area since it is conjectured that the reference plane must be available to extraneous users throughout the building. Since any of the proposed solutions meet specification requirements, each may be compared to incurred cost and the cheaper technique implemented. Indicated cable sizes are not those that are commercially available (except for 4/0), however, cables of approximately the same sizes can be substituted with a relatively small amount of error.

Example 2. PROBLEM: Consider a structure identical to Example 1 except that the resistance requirements is now 2.0×10^{-3} (ohms) rather than 25×10^{-3} ohms.

ANSWER: Allowing for 25% tolerance:

$$\begin{aligned} R &= 2(1 - .25) \times 10^{-3} \text{ (ohms)} \\ &= 1.5 \times 10^{-3} \text{ (ohms)} \end{aligned}$$

This value of ground resistance can only be obtained from Figure 47 for a foundation area of $(500 \text{ ft.})^2$. The grid should be constructed of 1.0 inch diameter solid copper cable, and should have no less than 13 grids per side.

Example 3. PROBLEM: A reference plane grid mesh is to be implemented in a rectangular structure of dimensions 150 ft. x 300 ft. $(45,000 \text{ ft.})^2$. The maximum grid resistance should be no greater than 1×10^{-3} ohms. The grid must cover the entire foundation area since many users are expected to depend upon it for usage.

ANSWER: Allowing for 25% tolerance:

$$\begin{aligned} R &= 1(1 - .25) \times 10^{-3} \text{ (ohms)} \\ R &= 0.75 \times 10^{-3} \text{ (ohms)} \end{aligned}$$

Since the required grid is rectangular in shape with a length to width ratio of 2 to 1, Figures 50 and 51 are applicable. The required resistance can be obtained by a grid constructed of 1 inch solid copper cable having no less than ten grids on the short side and 20 on the long side.

3.2.2 Materials to be Used, Size Requirements, Coatings, and Methods of Bonding Joints.

Copper cables are recommended for construction of grid reference planes due to their high electrical conductivity and their corrosion resistant properties. Cable size must be selected as a result of resistance

requirements and mechanical feasibility of implementation. Results of Section 3.2.1 can be used to select cable size for specific structure requirements.

Due to the corrosion resistance of copper it is felt that coating of conductors used in the mesh construction is both impractical and unwarranted. However, in cases where external connection is made to the reference grid mesh, moisture-proof coatings over bond connections will reduce the possibility of corrosion between mating surfaces and deterioration of welding materials. Such coatings may be in the form of a paint or plastic material capable of maintaining its moisture-proofing qualities over an extended period of time.

All overlapping joints in the grid construction should be electronically welded or fused together. Such welding techniques will minimize grid impedance, reduce the possibility of loose connections, and will result in a more rigid grid construction. All external connections to the grid mesh should be wrapped and electronically welded.

At no time should an external connection be made to the reference plane grid mesh by any metal other than copper or a metal which galvanically compatible with copper. Such connections will result in galvanic corrosion which may deteriorate the effectiveness of the reference plane.

3.2.3 Methods of Physically Implementing Reference Plane Ground Grid Mesh.

Numerous precautions must be adhered to for effective implementation of a reference plane grid mesh. Such precautions are listed below:

- (1) Adequate provisions must be made to accommodate all prospective users in various parts of the structure.
- (2) Tie-on points should be readily accessible for inspection purposes.
- (3) Mesh may be implemented under, between or as an integral part of flooring materials as long as such materials are non-conductive.

(4) Mesh must not make electrical connection with building structural steel or any other metallic media connected to earth ground, or the advantage of a single point earth ground will be forfeited.

Provisions must be made to accommodate all prospective users in the structure without affecting the primary purpose of the reference plane. If a structure contains more than one floor and if it is conjectured that users on more than one floor will require the convenience of a low impedance reference plane, then a grid mesh may be required for each floor. If, however, it is anticipated that users of the reference plane on other floors of the structure, are to be confined to a small area, then satisfactory results can be realized by running a reference plane jumper of relatively large diameter from the main reference plane grid mesh to the required work area. A good rule of thumb to follow in such circumstances is that the summation of the maximum reference plane resistance and the total resistance of the jumpers should be less than the resistance specified for the structure.

$$R_{\max}]_{RP} + R_J < R_{\text{spec}} \quad 3(28)$$

where

$R_{\max}]_{RP}$ = maximum design resistance of the reference plane grid mesh as determined in Section 3.2.1.

R_J = calculated resistance of jumpers from outermost points to the connection at the reference plane grid mesh.

R_{spec} = maximum specified resistance for the structure.

Jumpers may be constructed of either copper cables or solid rectangular copper bars. The resistance of each may be determined as follows:¹⁷

DC Resistance

$$R = \rho \frac{l}{A} \text{ (ohms)}$$

where:

ρ = resistivity of copper (ohms per circular mil foot)

l = length of conductor (feet)

A = cross-sectional area (circular mils)

¹⁷ Radio Engineer's Handbook, Frederick E. Terman, McGraw-Hill, 1943

AC Resistance

Wire:

$$R_{ac} = \frac{83.2\sqrt{f}}{d} \times 10^{-9} \text{ (ohms)} \quad 3(29)$$

Rectangular cross-section:

$$R_{ac} = K \frac{261\sqrt{f}}{2(a+c)} \times 10^{-9} \text{ (ohms)} \quad 3(30)$$

where:

f = frequency

d = outside diameter (cm)

a = width (cm.)

c = thickness (cm.)

K = factor determined from Figure 54 below

Figure 55 illustrates a typical application of such jumpers. Where a multitude of prospective reference plane users are contemplated on more than one floor, an excessive amount of jumper material would be required and the implementation of extra reference planes would be necessitated. Design techniques and implementation techniques previously discussed should be used. Jumpers should be implemented between the reference planes at various intervals.

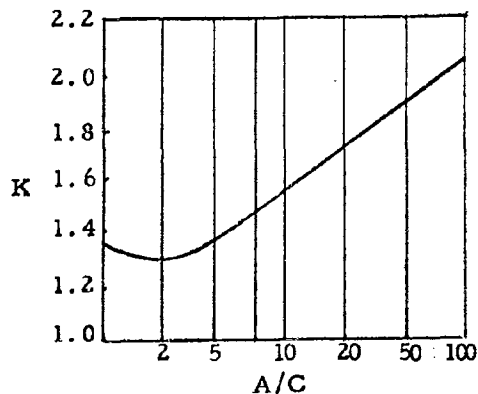

Figure 54 GRAPH FOR DETERMINING K FACTORS.

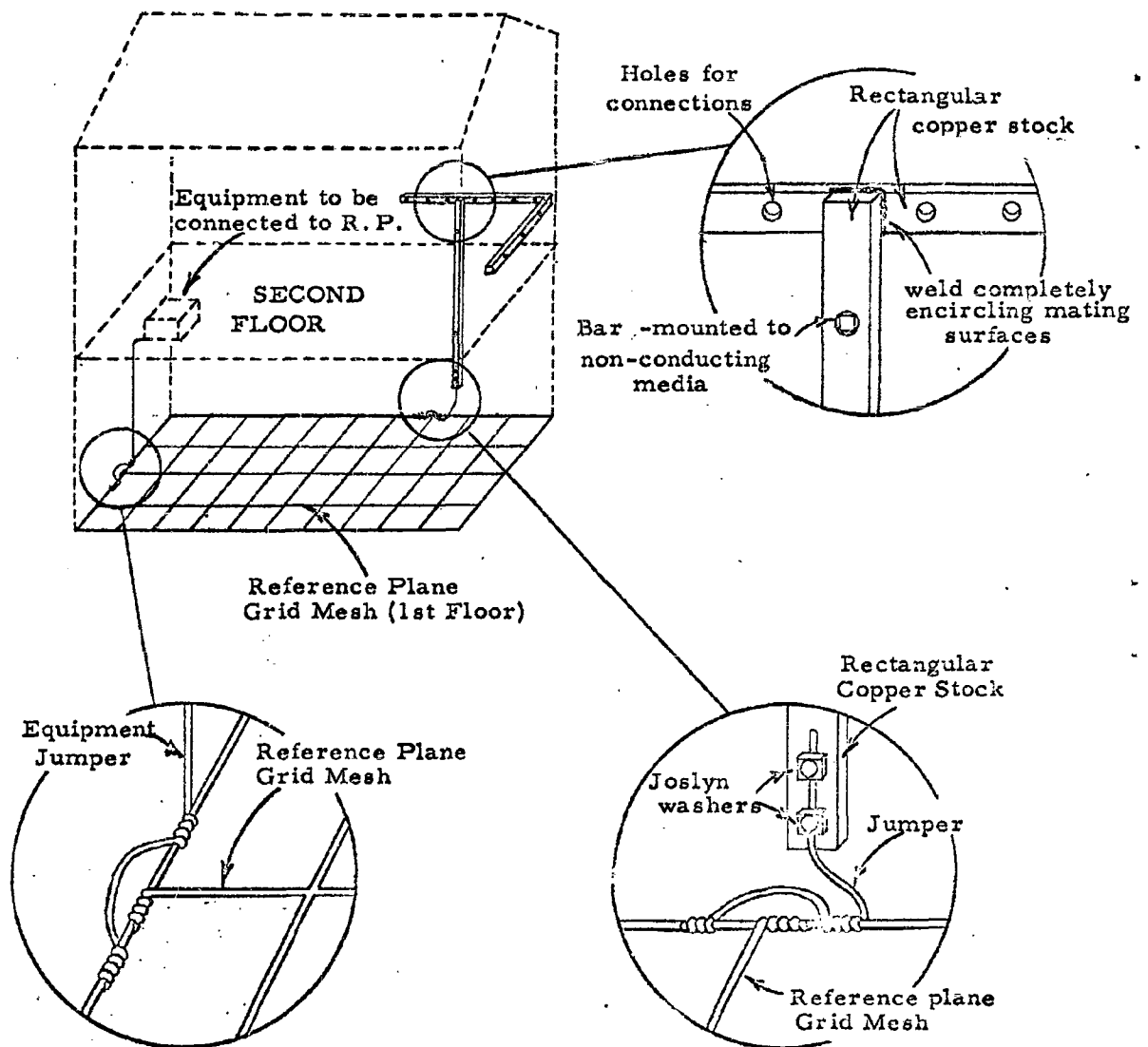

Figure 55. TECHNIQUES FOR IMPLEMENTING JUMPERS TO THE REFERENCE PLANE OF A MULTI-STORY BUILDING.

3.2.4 Method For Connecting Reference Plane Ground Grid Mesh to Earth Ground.

The reference plane ground grid mesh should be connected to earth ground for protection of personnel and equipment from hazardous potentials that might be induced upon it. Various precautions must be taken to insure that such measures are implemented in a manner which will not affect the primary purpose of the reference plane.

The importance of grounding the reference plane at only one point cannot be overemphasized. Each ground can be expected to carry large amounts of power system fault currents and possibly large currents due to lightning discharges. Such high level circulating loop currents must be isolated from the reference plane if at all possible.

Figure 56 illustrates a method for connecting the reference plane ground grid mesh to earth ground. Such procedures can be applied to any building using a reference plane and ground rods. In situations when earth ground meshes are used in lieu of or to compliment ground rods, techniques indicated in Sections 3.1.8 and 3.1.4 should be used for making earth ground connections.

Ground well installations should be made readily accessible for inspection and repair if necessary. Such installations should be installed in basements as above or in spaces between structure flooring and ground. More than one contact between the reference plane and the ground well and between the ground well and earth ground is desirable to prevent loss of earth ground by default of one contact.

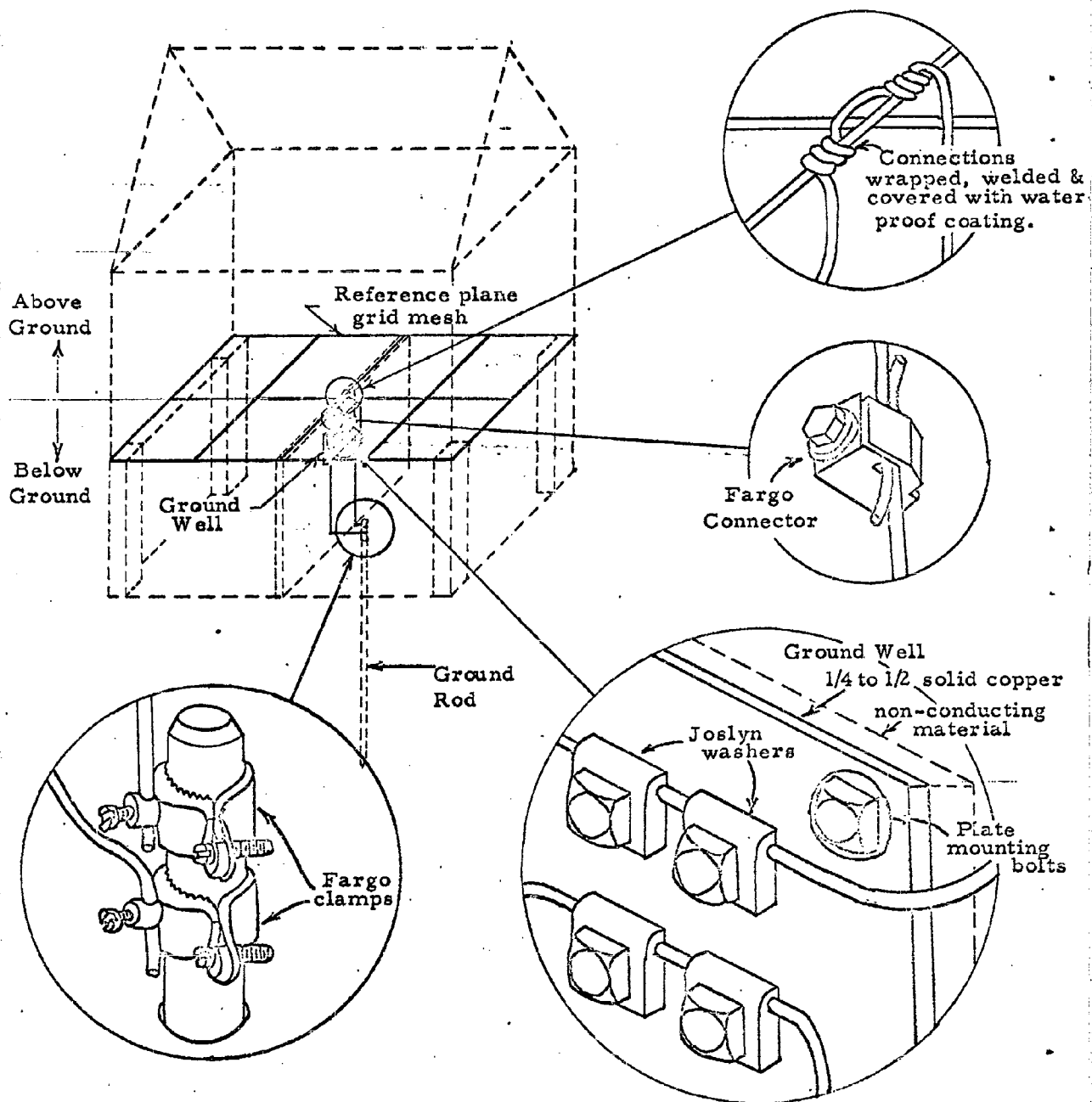

Figure 56. METHOD FOR CONNECTING REFERENCE PLANE GROUND GRID MESH TO EARTH GROUND.

4. CONCLUSIONS AND RECOMMENDATIONS.

The following conclusions and recommendations are based upon an analysis of studies performed on the various problem areas covered in this report.

4.1 Bond Impedance.

Conclusions:

- (a) The DC resistance and AC impedance offered by metallic mating surfaces in structural materials are primary sources of electromagnetic interference.
- (b) The resultant impedance between metallic mating surfaces varies drastically as a function of the technique used to bond such metallic members.
- (c) There is an existing void in RF impedance measurement techniques with resultant voids in bond criteria verification and inspection requirements.

Recommendations:

- (a) Preferred bonding techniques recommended in Section 2.1.2 of this report, should be complied with in order to minimize bond impedance between mating surfaces of metallic materials associated with building structures.
- (b) Future study programs should provide for the evaluation of preferred bonding techniques as well as all other bonding techniques associated with building construction, relative to resultant bond impedance over a broad frequency spectrum. Uniform test and evaluation techniques should be applied to all such bonds for evaluation purposes and establishment of maximum specification requirements.

4.2 Harmonic Generation:

Conclusion: Harmonic generation is a direct result of corrosion between mating surfaces of metallic materials and poses a potential conducted and radiated electromagnetic interference threat.

Recommendation: Recommendations presented in Sections 2.1.2, 2.1.1.3.1 and 2.1.1.3.2 of this report should be complied with in order to minimize electromagnetic interference effects resulting from harmonic generation.

4.3 Corona Discharge

Conclusion: Surface treatment of materials employed in structures located in high RF fields will contribute to corona occurrence if precautions are not adhered to.

Recommendation: Recommendations presented in Section 2.1.2 should be complied with to reduce the interference effects of corona discharge on structural materials subjected to intense RF fields.

4.4 Lightning Discharge

Conclusion: Lightning discharges may open or increase the impedance of bonds between metallic mating surfaces of structural materials or grounding systems, and cause circulating ground loop currents and radiation or reradiation of undesired energy from metallic members that are multiples of $\lambda/4$ wavelengths.

Recommendation: Recommendations presented in Section 2.2.2 should be complied with in order to minimize resultant electromagnetic interference implications which are associated with lightning discharges.

4.5 Electromagnetic Shielding

Conclusion:

(a) Effective shielding techniques can be recommended in structure design to attenuate electromagnetic energy emanating from within or without a structure.

(b) There is an existing void in measured data relative to the attenuation characteristics of commercially available construction materials.

(c) Past experience has indicated that exacting shielding requirements imposed as a result of electromagnetic interference considerations are not effectively implemented by construction personnel.

Recommendations:

(a) Shielding recommendations presented in Sections 2.4.1 through 2.4.4 of this report should be complied with as a first attempt to optimize shielding materials and techniques in the attenuation of radiated electromagnetic energy.

(b) Future study and measurement programs should be considered relative to determining the attenuation characteristics of commercially available construction materials and to provide for more effective implementation of shielding techniques.

4.6 Ground Rods.

Conclusions:

(a) Deep driven ground rods can be used to realize necessarily low ground resistances where compatible terrain considerations are existent.

(b) Copper ground rods are preferable due to their high electrical conductivity and corrosion resistant properties but create a problem due to galvanic corrosion of metallic underground systems constructed of less noble metals.

Recommendations:

(a) Recommendations presented in Sections 3.1.2 through 3.1.6 of this report should be adhered to in selecting optimum ground rod configurations which are compatible with specific structure requirements.

(b) Recommendations presented in Sections 3.1.3 and 3.1.4 should be complied with to insure effective implementation of selected ground rod configurations.

(c) Future study programs should be considered relative to possible solutions of the galvanic corrosion of underground piping and foundation systems resulting from the usage of copper ground rods and grounding systems.

4.7. Earth Ground Grid Meshes.

Conclusion:

(a) In specific circumstances the usage of earth ground grid meshes is effective in complimenting or replacing ground rods as a grounding media. In cases where deep driven ground rods are excluded due to terrain considerations, grid meshes can be effectively used to replace or compliment shallow driven ground rods.

(b) Lower values of grounding resistance can be realized by usage of deep driven ground rods than by usage of earth grid meshes.

Recommendations:

It is recommended that criteria presented in Sections 3.1.7 through 3.1.9 be adhered to for earth grid usage, optimum design criteria and effective implementation.

4.8 Reference Plane Ground Grid Meshes.

Conclusions:

(a) Low impedance reference plane ground grid meshes are essential in building construction to provide a equi-potential reference plane to extraneous electronic and shield media users.

(b) Connection to earth ground is not essential for a reference plane to perform its intended function, but a single earth ground connection will preclude the development of potentials, with respect to ground, that might prove hazardous to personnel or equipment. A single earth ground connection will also preclude circulating earth ground currents from being introduced on to the reference plane.

Recommendations:

(a) All buildings housing electronic equipments which are either susceptible to or capable of generating electromagnetic energy, should include a low impedance reference plane ground grid mesh.

(b) Reference planes should be designed and implemented as recommended in Sections 3.2.1, 3.2.2, 3.2.3, and 3.2.4 of this report.

BIBLIOGRAPHY

1. Cobine, J. D., Gaseous Conductors, Theory and Engineering Applications, McGraw-Hill, 1941.
2. Meek, J. M., Craggs, J. D., Oxford, "The Electrical Breakdown of Gases," Clarendon Press, (1953).
3. Peek, F. W., Jr., Dielectric Phenomena in High Voltage Engineering, McGraw-Hill, 1929.
4. Ragan, G. L., "Microwave Transmission Line Circuits," Vol. 9, Radiation Laboratory Series (M. I. T.), pp. 227-242, 1948 (Results of Rad. Lab. experiments on voltage breakdown at microwave frequencies).
5. Ryan, J. W., "Bibliography on Corona", General Electric - General Engineering Laboratory, Feb. 10, 1955, ASTIA AD 102336.
6. Doolittle, J. E., "Supplement to Bibliography on Corona", Feb. 1, 1956, ASTIA AD 102335.
7. "Bibliography on High Voltage Transmission Line Corona and Radio Interference and Fundamental Corona Processes", (Revised 1958) ERB-491, National Research Council, Ottawa, Ontario, Canada.
8. "A Survey of the Literature on Microwave Breakdown", Contract Nobsr 52601, Wheeler Labs Rpt. 477; ASTIA AD 90298
9. Devins, J. C. and Sharbaugh, A. H., "The Fundamental Nature of Electrical Breakdown", Electro-Technology, February 1961, pp. 103-122.
10. Sharbaugh, A. H., and Devins, J. C., "Electrical Breakdown in Solids and Liquids", Electro-Technology, October, 1961, pp. 97-116.
11. Birx, D. L., Johns Hopkins Univ., 1954, "The Electric Strength of Air in Nonuniform Fields at Radio Frequencies", ASTIA AD 44159.
12. "High-Frequency Gas-Discharge Breakdown", Research Laboratory of Electronics, M. I. T., Technical Report 301, 25 July 1955, ASTIA AD 85873.
13. Brown, S. C., M. I. T., "Microwave Gas Discharge Breakdown", ASTIA AD 85883.

14. "Report of a Review of Past and Current Work on Electromagnetic Interference Voltage from Electric Power Transmission Lines," The Hinchman Corporation Engineers, Contract Noy88454, Dept. of the Navy, Bureau of Yards and Docks, Wash. D.C., 23 Nov. 1955. ASTIA AD 108685.
15. "Plastics Lab. Tech. Report, 43C, ARC Resistance, Radio Frequency Corona Resistance", Princeton University, Contract No. DA-36-039SC-70154, 15 Nov 1956, ASTIA AD 115141.
16. "Ninth Interim Development Report on Microwave High Power Breakdown Study", 1 Sep 1955, Contract Nobsr 63295, ASTIA AD 122264.
17. "Corona Retardent for Capacitors", Contract AF 33(616)-6459, Westinghouse Research Lab., ASTIA AD 225536.
18. "A Study of Corona Discharge Noise in Aircraft Antennas", Stanford Research Institute, Contract AF 19(604)-3458, Aug 60, ASTIA AD 249378.
19. "Study of VLF Corona", U.S. Navy Electronics Lab., Report 1044, 4 May 1961, ASTIA AD 260296.
20. "Evaluation of Interference Suppression of Fluorescent Lamps", U.S. Naval Civil Engrg. Lab., 6 Oct 1961, Tech. Rpt. 166, ASTIA AD 265780.
21. "Electrical Breakdown in Vacuum", U.S. Naval Research Lab., 2 October 1961, NRL Report 5671, ASTIA AD 26603.
22. "Evaluation of the Interference-Suppressing Power Conductor", U.S. Naval Civil Engineering Lab., 20 Dec. 1961, Tech. Rpt. 178, ASTIA AD 268730.
23. "Artificial Atmospheric Generation - II, Final Report Covering the Period July 1957 through Sept. 1960", Lightning and Transients Research Institute, Contract No. AF 19(604)-2421, ASTIA AD 272850.
24. "Study of Noise Properties of Gas Discharge", University of Minnesota October 1961, Electronic Technology Lab. Contract No. AF 33 (616)-5479, Project No. 4150, ASTIA AD 273248.
25. "Research and Development on Corona Resistant Materials", General Electric Research Lab., March 1962, Contract No. AF 33(616)-7485, Project No. 7371, ASTIA AD 277378.
26. "Failure Mechanisms in Ultra High Power Transmission Lines", Microwave Associates, Inc., 19 June 61 to Dec 19, 1961, First Quarter Progress Report, Contract No. AF 30(602)-2545, ASTIA AD 277925.

27. "A Study of A-C Corona Voltage Levels", Research Test No. T-29602, 1-20-56, Boeing Airplane Co., ASTIA AD 141687.
28. Rudy, J. F., "Minimizing RF Interference from Arc Welding", Armour Research Foundation, Contract Nobsr - 81144, October, 1962.
29. Diamesis, J. E., "Investigation of Corona Noise in a Three-Phase Transmission Line", Proc. of the Fifth Conference on Radio Interferences Reduction, Armour Research Foundation 1959.
30. Diamesis, J. E. and Haber, F. "Corona Noise Models Based on Modulated Gaussian Noise", Proc. of the Sixth Conference on Radio Interference Reduction, Armour Research Foundation, 1960.
31. Alexy, M. Raymond, "Contact Arcing Factors to 100,000 Feet," Electrical Manufacturing, June 1956.
32. Starr, W. T., "High-Altitude Flashover and Corona Problems," General Electric Co., Schenectady, New York, Electro-Technology, June, 1962.
33. Wheeler, Harold A., "Air Breakdown Chart for Radar Pulses", Wheeler Lab., Great Neck, N. Y., Electronics, August 1952.
34. Wechsung, W. "Radio Interference Due to Corona Discharges on High-Tension Lines", National Research Council of Canada, Technical Translation 741, Ottawa, 1958.
35. Frisco, L. J., "Frequency Dependence of Electric Strength... A Design Consideration Analysis", Electro-Technology, August, 1961.
36. Slater, J. C. and Frank, N. H. Electromagnetism, McGraw-Hill, 1947.
37. Schelkunoff, S. A., Electromagnetic Waves, D. Van Nostrand Co., 1943.
38. Ramo, S. and Whinnery, J. R., Fields and Waves in Modern Radio, John Wiley and Sons, 1944.
39. Skilling, H. H., Fundamentals of Electric Waves, John Wiley and Sons, 1948.
40. Vasaka, C. S., "Theory, Design and Engineering Evaluation of Radio Frequency Shielded Rooms", U.S. Naval Air Development Center, Report No. NADC - EL-54129, 13 Aug. 1956, ASTIA AD 117564.
41. U.S. Air Force CED 3500; AFM 100-35; "Mutual Electromagnetic Interference"; 1 Sept 1960.

42. Nicholson, P. F., "Study of Coke-Aggregate Concrete as a Shield to Electromagnetic Radiation", NRL Report No. 5473, May 6, 1960 . ASTIA AD 238302.
43. Dinger, H. E. and Raudenbush, J. E., "A Technique for Measuring the Effectiveness of Various Shielding Materials", NRL Report No. 4103, January 22, 1953, ASTIA AD 9353.
44. Klouda, R. G., "Requirements of Measurements of Shielded Installations", Proc. 7th Conf. on Radio Interference Reduction and Electronic Compatibility, Armour Research Foundation, November 1961.
45. Jarva, W. "Shielding Efficiency Calculation Methods for Screening, Waveguide, Ventilation Panels, and Other Perforated Electromagnetic Shields", Proc. 7th Conf. on Radio Interference Reduction and Electronic Compatibility, Armour Research Foundation, November, 1961.
46. "Measurements of Electromagnetic Wave Attenuation Characteristics of Portable Shelters Composed of Pliable Reflecting Materials", Pickard and Burns, Inc., 15 April 1959, ASTIA AD 234762.
47. Kanellakos, D. P. and Peach, L. C., "A Coaxial Device for Measuring the Performance of Shielding Materials", Proc. 5th Conf. on Radio Interference Reduction and Electronic Compatibility, Armour Research Foundation, October, 1959.
48. Cuming, W. R., "Materials for RF Shielded Chambers and Enclosures", Symposium Digest, 4th National Symposium on RFI, June, 1962.
49. "Shielding by a Thin Conducting Sheet Against Transient Electromagnetic Signals", Contract Nonr - 1866(26), 10 Aug 59, Cruft Lab., Harvard Univ., ASTIA AD 235694.
50. "Reflection, Transmission and Absorption of Plane Electromagnetic Waves by Lossy Dielectric Panels, " Ohio State University Research Foundation, Contract Number AF 33(616)-5341, 31 Aug 1960, ASTIA AD 244536.
51. "Final Report on Dev. of an Air Transportable Shelter for Ground Electronic Equipment", Contract AF 30(602)-205, 15 May 1954, ASTIA AD 43896.
52. "Research Leading to the Development of a Shielding Effectiveness Tester" Carnegie Institute of Technology, Final Report June 15, 1954, to June 15, 1956, Contract No. DA-36039 SC 63194, ASTIA AD 104278.

53. "Studies Leading to the Development of an Electromagnetic Darkroom" Contract Noy-73242, Progress Report, October 1956, ASTIA AD 222138.
54. "Radio Frequency Anechoic Lab. Design Study", HRB-Singer, Inc. State College, Penn., AF-30(602)-2445, Task I, November 1961, ASTIA AD 273225.
55. "Final Report for Buried Cable Radiation Studies", Cooke Engrg. Co., 15 April 1961, Contract NBy 17827, ASTIA AD 275390.
56. Wheeler, Harold A. "Universal Skin-Effect Chart for Conducting Materials", Wheeler Lab., Inc., Great Neck, N. Y., Electronics, November 1952.
57. Schreiber, O. P., "Some Useful Analogies for RF Shielding and Gasketing", Technical Wire Products, Inc., Springfield, New Jersey, Presented at the Tutorial Session of the Third National Symposium on Radio Frequency Interference, Washington, D. C., June 12, 1961.
58. Nicholson, P. F., "Electromagnetic Shielding with Coke", NRL Memorandum Report 1080, U.S. Naval Research Laboratory, Washington, D. C., 18 July 1960.
59. Vasaka, C. S., "Shortcuts to RF Shield Design", Electronic Industries & Tele-Tech, March 1957.
60. Kenny, H. W. and Conard, B. L. "RFI Shielded Enclosures", Electrical Design News, Sept. 1962, Ace Engineering and Machine Co., Inc., Huntingdon Valley, Pa.
61. Butterfield, Brian "Polyform, A New Approach to Electromagnetic Shielding Enclosures", Electrical Design News - August 1962 Barber-Columan Co., Aircraft and Missile Div., Rockford, Ill.
62. Kanellakos, D. P. and Schulz, R. B., Armour Research Foundation, Chicago, Illinois, L. C. Peach, Illinois Institute of Technology, Chicago, Illinois, A. P. Massey, Bureau of Ships, Dept. of Navy, Washington D. C., "New Techniques for Evaluating the Performance of Shielded Enclosures", 5th Armour Conf., October 1959.
63. "Revision of Standards for Measurements of Shielding Effectiveness of Enclosures", Armour Research Foundation, Contract Nobsr 72824, October 1959, OTS PB 157574.
64. Design Techniques for Interference - Free Operation of Airborne Electronic Equipment, Frederick Research Corp., Bethesda, Maryland, Contract AF 33(038)23341, 1952.

65. Hill, "The Shielding of Radio Waves by Conductive Coating", IRE Trans. Ant. and Prop., Vol. AP-3, No. 2, April 1955.
66. DeVore, C. "Measuring Effectiveness of Shielding Materials", Electrical Manufacturing, Vol. 52, No. 2, August 1953.
67. Newman, D.J., "Radiation Absorbers, -Their Selection and Use", Electronic Design, February, 1957.
68. Gierhart, G.D., et.al. "Insertion Loss of a Frame Wall at SHF", NBS Report 7273, Boulder Labs, June 26, 1962.
69. Gierhart, G.D., et al, "Insertion Loss of a Brick Wall at UHF", NBS Report 7272, Boulder Labs, June 26, 1962.
70. Cale, N.H., "A Comparison of RF Shielding Materials", Electronic Industries, Dec. 1962.
71. Holm, Ragnar, Electric Contacts Handbook, Springer-Verlag, Berlin, 1958 (in English).
72. "Bonding Materials, Metallic Mating Surfaces, Low RF Impedance", Contract AF 33(038)-23583, November 1954, Armour Research Foundation, ASTIA AD 61987.
73. Schrieber, O.P., "Reliable Electrical Contact Theory Applied to RFI Control", Presented at Fourth National Symposium on Radio Frequency Interference, IRE, San Francisco, California, June 28-29, 1962.
74. "Ground Constants Measuring Set, Lab. Procurement Office, Signal Corps Supply Agency", 30 October 1954, Contract No. DA-36-039-SC-42709, ASTIA AD 54799.
75. "A Study of Earth Currents Near A.V.L.F. Monopole Antenna with a Radial Wire Ground System", 6 Feb. 1957, NBS Project 8320-20-8821 NBS Report 5047.
76. A.M. Seybold, "Harmonic Radiation From External Nonlinear Systems; Sources Characteristics, and Methods of Detection" QST, January 1953.
77. Communications Navigational Aids and Air Field Lighting, Design Manual, DM-23, Navy Dept., Bureau of Yards & Docks
78. Rosa, E.B. and Grover, F.W., Formulas and Tables for the Calculation of Mutual and Self Inductance, Vol.VIII, No. 1, PT.1-237, Jan 1, 1912.
79. Corockraft, J.D., "Skin Effect in Rectangular Conductors at High Frequency", Proceedings of Royal Society "London", Vol. 122, No. A790, 0533, Feb. 4, 1929

80. "Corrosion", M/DE Special Report, Materials & Design Engineering, Jan. 1963. pages 84-122
81. Seabright, L.H. and Fabian, Robert J., "Coatings to Prevent Corrosion:" Materials & Design Engineering, Jan. 1963.
82. Emerson & Cumming, Inc., Preliminary Technical Bulletin, 11-2-9.
83. The National Electrical Code, National Board of Fire Underwriters, 1962.
84. Schwartz, S.S. "Analytical Expressions for the Grounding Resistance of Grounding Rods!", Transactions of AIEE, August 1954.
85. Dwight, A. B., "Calculations of Resistance to Ground", Electrical Engineering Transactions of AIEE Vol. 55, Dec. 1936, PP 1-13.
86. Higgs, P.J. "An Investigation of Earthing Resistance", IEE Journal, Vol. 68, pg. 736, Feb. 1930.
87. Town, H.M. "Lightning Arrestor Grounds, Parts I, II, III" General Electric Review, Vol. 35, pgs. 153 - 215, and 280, March April, May 1932.
88. Wenner, Frank, A Method of Measuring Earth Resistivity, Bulletin, US Bureau of Standards, Vol. 12, 1916
89. Sunde, Erling D., Earth Conductivity Effects in Transmission Systems, D. Van Nostrand Co., Inc., page 51.
90. FCC Rules & Regulations, Vol. 3 pgs. 49-87.
91. Reed & Russel, Ultra-High Frequency Propagation, John Wiley & Sons, Inc., New York, pages 156-160.
92. S.J. Schwarz, "Analytical Expressions for Grounding System Resistance" Transactions of AIEE, Aug 1954.
93. Terman, Frederick E., Radio Engineers Handbook, McGraw-Hill 1943.
94. Bladholm, E.F. and Kormendy, L.J. Cathodic Protection, Materials Protection, Feb. 1963, pages 20-27.
95. Britton, S.C., Tin and Tin Coatings - Their Resistance to Corrosion, The Tin Research Institute, publication nr. 280.
96. Abbott, W.K. and Schillmoller, C.M. Materials Protection "Survey of Electrical Grounding Problems" Nov. 1962 pages 48-60.

97. Kouwenhoven, W.B. and Sackett, Jr., W.T., "Contact Resistance -The Contribution of Non-Uniform Current Flow" Electrical Engineering, March 1962, pages 264-268.
98. Eaton, J.R. , Grounding Electric Circuits Effectively, James G. Biddle Co., Bulletin No. 25T2.
99. Zaborszky, J. and Rittenhouse, Joseph W., Design Charts for Determining Optimum Ground Rod Dimensions, Transactions of the AIEE, August 1953, pages 810-815.
100. Gross, T.B. and Wise, Richard B., "Grounding Grids for High-Voltage Stations, Resistance of Large Rectangular Plates," Transactions of the AIEE Oct. 1955 pages 801-809.
101. Gross, T.B. Wallman, E. J., "Grounding Resistance of Small & Large Sub-stations", Transactions of the AIEE, March 1961 pages 198-199.
102. Appleman, Glen and Litrides, S.J., "All Steel Network Ground Sub-stations," Electrical World, May 2, 1955, pages 59-61.

APPENDIX I

DERIVATIONS OF GROUND RESISTANCE
REALIZED BY ROBBEDS AND GRID MESHES.

BASIC CONCEPTS

A sphere embedded in earth and dissipating current I induces at some point in the ground a potential of

$$P_o = \frac{\rho I}{4\pi} \left(\frac{1}{r} + \frac{1}{r'} \right) \quad I(1)$$

where: p = soil resistivity, ohm-centimeters
 r = distance from center of sphere to point, cm.
 r' = distance from image of center to point, cm.

If x_o, y_o, z_o designate the coordinates of the point and the center is located at x, y, z

$$r^2 = (x - x_o)^2 + (y - y_o)^2 + (z - z_o)^2$$

$$(r')^2 = (x - x_o)^2 + (y - y_o)^2 + (z - z_o)^2$$

The coordinate z is measured as vertical distance from the earth surface, in positive sense downward and in negative upward.

Several spheres 1, 2, 3...n, distributed in earth and each dissipating a current I_1, I_2 and $I_3 \dots I_n$ into ground, will cause at the point x_o, y_o, z_o a potential

$$P_o = \frac{\rho}{4\pi} \left(\sum_1^n j \frac{I_j}{r_{j_o}} + \sum_1^n j \frac{I_j}{r_{j_o}'} \right) \quad I(2)$$

Herein j is taken successively as 1, 2, 3...n; r_{j_o} and r_{j_o}' respectively indicate the distances from each center of sphere and its image to the point. If all spheres are connected by insulated wires, the total ground current is

$$I = \sum_1^n j I_j$$

If the spheres are now arranged for form a continuous conductor, the center of which follows a curve described by $f(x, y, z)=0$ and the current dissipated along the conductor is given as $i = \varphi(x, y, z)$, Equation I(2) assumes the form

$$P_o = \frac{\rho}{4\pi} \int_L \left(\frac{1}{r} + \frac{1}{r'} \right) \frac{\partial i}{\partial s} ds \quad I(3)$$

$$ds = \sqrt{(dx)^2 + (dy)^2 + (dz)^2}$$

The integral is to be taken over the full length L of the conductor. If point (x_o, y_o, z_o) is now placed at the conductor surface and successively moved over this surface, Equation I(3) will furnish an expression for the potential distribution there. However, since the potential at the surface of a metallic conductor must be constant, $i = \varphi(x, y, z)$ will have to satisfy Equation I(3) as a constant value. The difficulty in finding a practical solution led to Howe's concept of the "average potential" method, which is based on substituting an average current density

$$\frac{\partial i}{\partial s} = \frac{I}{L}$$

in Equation I(3). This in turn produces a potential P_o on the conductor surface varying with x_o, y_o, z_o . To satisfy again the equipotential condition, the average of P_o is taken by

$$P = \frac{1}{L} \int_0^L P_o ds \quad I(4)$$

The result, although not strictly correct, is of sufficient accuracy.

Applied to a straight horizontal wire, Equations I(3) and I(4) furnish for the resistance to ground

$$R = \frac{P}{I} = \frac{\rho}{2\pi L} \left[\sinh^{-1} \frac{L}{a} - \sqrt{1 + \left(\frac{a}{L}\right)^2} + \frac{a}{L} + \sinh^{-1} \frac{L}{2z} - \sqrt{1 + \left(\frac{2z}{L}\right)^2} + \frac{2z}{L} \right] \quad I(5)$$

where: L = conductor length, cm
 $2a$ = conductor diameter, cm
 z = depth to which conductor is buried, cm

For practical purposes, where $a \ll L$ and $2z \ll L$, Equation I(5) can be written

$$R = \frac{\rho}{\pi I} \left(\log_{\epsilon} \frac{2L}{a'} - 1 \right) \quad I(6)$$

with $a' = \sqrt{a \times 2z}$. The factor $2z$ represents the average distance from centerline of the wire image to the conductor surface. If the conductor is located on earth surface with its centerline at ground level, $2z = a$ and $a' = a$.

The solution for the resistance of a vertical rod, taking into account that $b \ll L_1$, is

$$R = \frac{\rho}{2\pi L_1} \left[\log_{\epsilon} \frac{4L_1}{b} - 1 + \log_{\epsilon} \frac{1 + z/L_1}{1 + 2z/L_1} + \frac{z}{L} \log_{\epsilon} \frac{4z/L_1 + 4(z/L_1)^2}{1 + 4z/L_1 + 4(z/L_1)^2} \right] \quad I(7)$$

where: L_1 = length of rod, cm
 $2b$ = diameter of rod, cm
 z = depth of earth fill over top of rod, cm

For the commonly-used 10-foot-long ground rod of 3/4-inch diameter, $R = 3.2 \times 10^{-3} \rho$ ohm for the rod driven to ground level and $2.75 \times 10^{-3} \rho$ ohm for the rod driven 2 feet into ground.

To compute the combined resistance of two or more parallel-connected grounding systems, their influence upon each other affects the result. If two systems such as those shown in Figure I-1 are considered, the potential induced at some point y at the surface of L_1 by the current I in L can be found from Equation I(3) as

$$P_{1y} = \frac{\rho I}{4\pi L} \int_L \left(\frac{1}{r} + \frac{1}{r'} \right) dx \quad I(8)$$

If now all potentials thus induced on the surface of L_1 are averaged and the resulting mean value P_{12} is divided by I , an expression is obtained

$$R_{12} = \frac{P_{12}}{I} = \frac{\rho}{4\pi L L_1} \int_0^{L_1} \int_0^{L_1} \left(\frac{1}{r} + \frac{1}{r'} \right) dx dy \quad I(9)$$

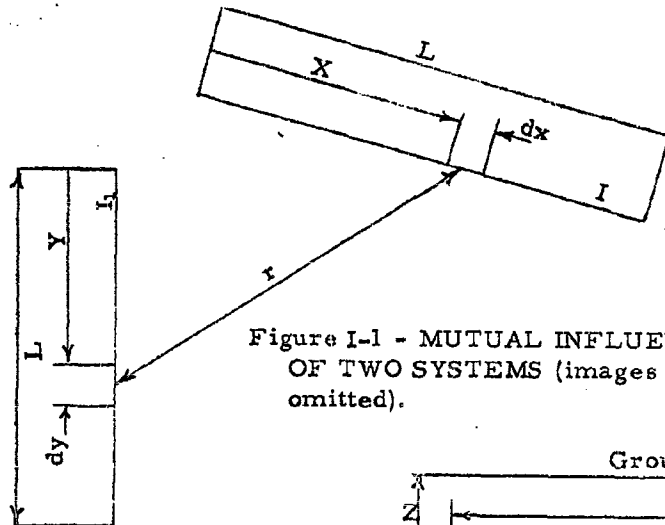

Figure I-1 - MUTUAL INFLUENCE OF TWO SYSTEMS (images omitted).

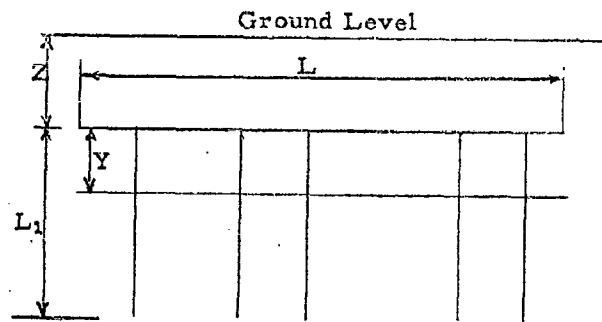

Figure I-2 - STRAIGHT HORIZONTAL WIRE WITH ARBITRARILY LOCATED RODS ATTACHED.

which has the dimension of a resistance and is called the mutual resistance of L on L_1 .

If both systems L and L_1 have only linear extension, surface and centerline of each conductor practically coincide. The distances from points of one system to the points of the other can then be taken as identical and the image points of one as equidistant from the real points of the other. Thus the quotient of the average potential p_{21} , induced on L by current I_1 of L_1 , divided by I_1 will produce the same result as Equation I(9). However, it is well to remember that the identity $R_{21} = R_{12}$ holds strictly for only 1-dimensional extensions of L and L_1 .

Applied to the case of Figure I-2, Equation I(7) can be set up as

$$p_{1y} = \frac{\rho I}{\pi L} \left[\log_e \frac{2L}{\sqrt{y(y+2z)}} - 1 \right]$$

which as a modification of Equation I(6) averages the influence of L on all the points of the scattered rods at distance y . Taking now the mean value of potentials p_{1y} over the full depth of L_1 results in

$$R_{1s} = \frac{E_{1s}}{I} = \frac{\rho}{\pi L} \left[\log_e \frac{2L}{\sqrt{L_1(L_1+2z)}} - \frac{z}{L_1} \log_e \frac{L_1+z}{2z} \right] = R_{s1} \quad \text{I(10)}$$

or

$$R_{1s} = R_{s1} = \frac{\rho}{\pi L} \log_e \frac{2L}{L_1} \quad \text{for } z = 0 \quad \text{I(11)}$$

The combined resistance of several elements can be determined if the resistances of each element alone $R_{11}, R_{22}, R_{33}, \dots$ and their mutual resistances $R_{12}, R_{13}, R_{21}, R_{23}, \dots$ are known. As indicated by Equation I(2) if applied successively to the surface of each element, the potential to ground being equal for the whole system will be

$$\begin{aligned} P &= R_{11} I_1 + R_{21} I_2 + R_{31} I_3 + \dots \\ &= R_{12} I_1 + R_{22} I_2 + R_{32} I_3 + \dots \\ &= R_{13} I_1 + R_{23} I_2 + R_{33} I_3 + \dots \\ &\quad \cdot \quad \cdot \quad \cdot \\ &\quad \cdot \quad \cdot \quad \cdot \\ &\quad \cdot \quad \cdot \quad \cdot \end{aligned} \quad \text{I(12)}$$

By solving this set of equations and summing up $I_1 + I_2 + I_3 + \dots = I$, the total resistance of the system is found as $R = P/I$. For only two components

$$R = \frac{R_{11}R_{22} - R_{12}R_{21}}{R_{11} + R_{22} - R_{12} - R_{21}} \quad \text{I(13)}$$

DERIVATION OF EQUATION FOR
GROUND RESISTANCE OF GRID MESH

The basic concepts applied to a straight horizontal conductor furnished Equation I(5) for the resistance. Any deviation from a straight extension will cause an increase in the induced voltage owing to the lower range of the variables r and r' in Equation I(3). Hence the resistance of such a conductor can be written as

$$R = \frac{\rho}{\pi L} \left(\log_{\epsilon} \frac{2L}{a'} - 1 + N \right) \quad \text{I(14)}$$

The inclusion of N in the bracketed expression is justified, because the factor $1/L$ outside the bracket signifies the linear current density of the arrangement and thus applies to the full bracketed expression. The additive term $(N-1)$ is -0.45 for a simple circular loop and -0.16 for a square loop which can be easily found by rearranging known equations for these configurations. Other values of $(N-1)$ for rectangular loops of various length to width ratios, calculated in similar manner are plotted in Figure I-3.

If additional wires are connected to and placed inside of the loop, $(N-1)$ will increase with any addition to the total length of the conductors, until finally the resistance of a metallic plate $(\rho/\pi)(k_1/\sqrt{A})$ is approached. With the conductor length L within the area A increasing toward infinity, the first term in Equation I(14) vanishes and

$$\lim_{L \rightarrow \infty} R = \lim_{L \rightarrow \infty} \frac{\rho}{\pi L} (N-1) = \frac{\rho}{\pi L} \left(k_1 \frac{L}{\sqrt{A}} \right) \quad \text{I(15)}$$

From Equation I(15) it can be deduced that the additive term $(N-1)$ for any wire configuration within a given area must be related to the dimensionless ratio $\alpha = L/\sqrt{A}$, the density of total conductor length per linear extension of the area. If Equation I(14) is modified accordingly

$$R = \frac{\rho}{\pi L} \left(\log_{\epsilon} \frac{2L}{a'} + f\alpha \right)$$

and f herein is expressed as a power series

$$f = k_1 + \frac{k_2}{\alpha} + \frac{k_3}{\alpha^2} + \dots$$

a general expression is obtained which will satisfy Equation I(15) for $\alpha = \infty$. It depends then solely on a proper selection of the coefficients $k_2, k_3 \dots$ to establish the correct relationship of resistance to any α for the plate and minimum α for the loop encircling the same area. Close approximation to actual results can be achieved by breaking off the series after the first two terms and solving for k_2 from the second limiting condition, the loop. The relation

$$N - 1 \approx k_1 \alpha + k_2$$

allows the computation of k_2 from the known data for the loop around the particular area. If, e. g., $\alpha = 4$ for the square, $k_1 = 1.27$, and $(N-1) = -0.16$ (from Figure I-3), then coefficient k_2 becomes -5.64 . Values of k_2 for other shapes of area and various depths can be computed in a similar manner. All these values are negative. If now, for convenience their positive equivalent is used, $(N-1)$ is to be written as

$$N - 1 = k_2 \alpha - k_2$$

and this relation entered in Equation I(14) furnishes the desired grounding equation.

DERIVATION OF EQUATION FOR GROUND RESISTANCE OF ROBBED

For the following investigation it is assumed that n vertical rods of equal dimensions are connected in parallel with the interconnecting wires either insulated or carried above ground. The combined resistance to ground is $1/n$ times the resistance of a single rod, only if the rods are driven so far apart as not to cause mutual influence. If placed at closer spacings, an additive term N has to be introduced and the expression for the combined resistance can be written with the notations of Equation I(7) for $z = 0$ as

$$R = \frac{\rho}{2\pi n L_1} \left(\log_{\epsilon} \frac{4L_1}{b} - 1 + N \right) \quad \text{I(16)}$$

This expression is a simplification based on the concepts of the average potential theory presuming equal currents in every rod, to wit, the factor $1/n$ outside the bracket. Strictly speaking, increasing current will be

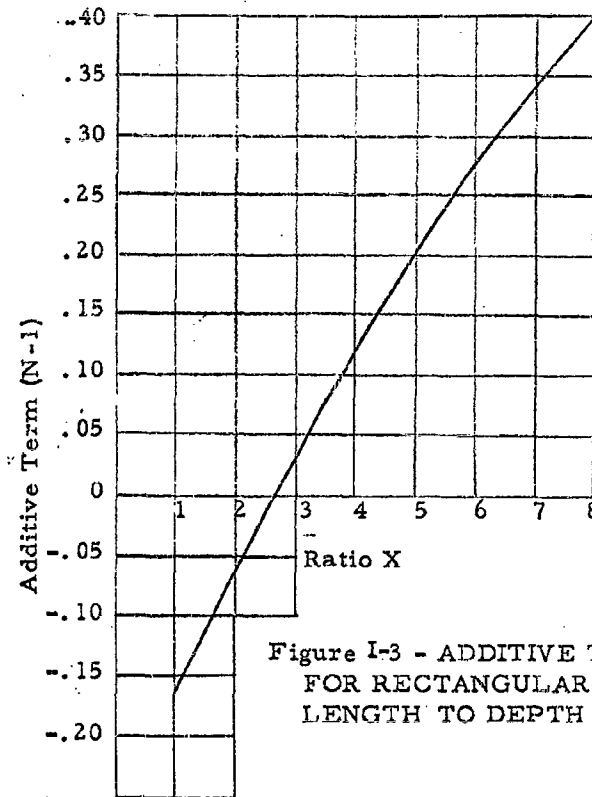

Figure I-3 - ADDITIVE TERM (N-1)
FOR RECTANGULAR LOOPS OF VARIOUS
LENGTH TO DEPTH RATIOS X.

carried by rods at greater distances from the center in an arrangement as shown as shown in Figure I-4. The exact method would involve solving n simultaneous equations similar to Equation I(12). However, the small gain in accuracy would hardly warrant this cumbersome procedure. It may also be noted that for reasons of simplification the resistance for rods driven to ground level has been entered in Equation I(16). The error committed hereby in the case of rods driven to any depth of usual practice is small and further reduced by the influence of N .

The term N must be a function of the spacings between each of the n rods with all the other $(n-1)$ rods. These spacings in turn are related to the linear extension of the area A , viz., the dimensions \sqrt{A} . If the number of rods is increased toward infinity, for instance within a square area, the resistance of the square plate is approached

$$\lim_{n \rightarrow \infty} R = \frac{\rho \cdot 2.74}{2\pi \sqrt{A}} \quad \text{I(17)}$$

or

$$N \Big|_{n=\infty} = 2.74 \frac{L_1}{\sqrt{A}}$$

On the other hand, the smallest number of rods for this area is four, i. e., one rod placed at each corner. With $\sqrt{A} \gg L_1$ the resistance of this combination (see Figure I-5)

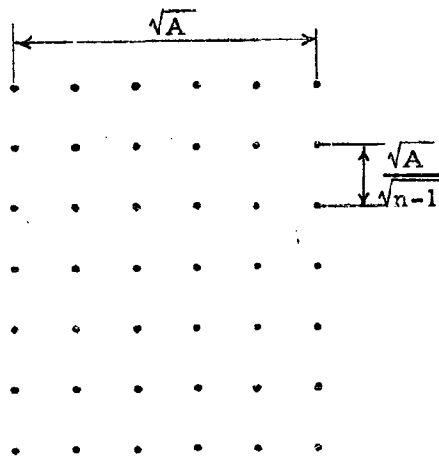

Figure I-4 - ARRANGEMENT OF n EQUALLY-SPACED GROUND RODS IN A SQUARE AREA.

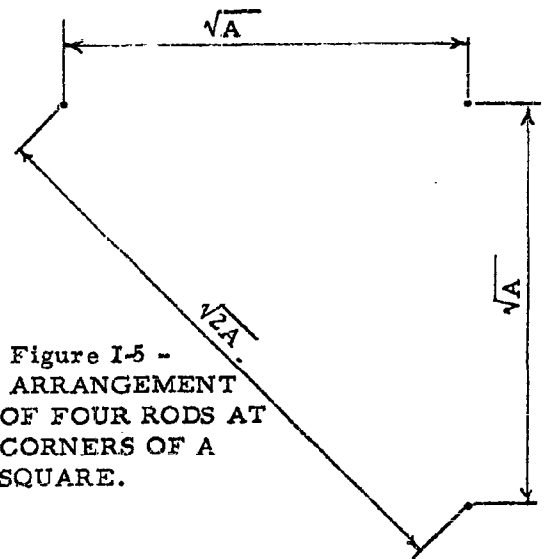

Figure I-5 - ARRANGEMENT OF FOUR RODS AT CORNERS OF A SQUARE.

$$R = \frac{\rho}{8\pi L_1} \left(\log_e \frac{4L_1}{b} - 1 \right) + \frac{\rho}{8\pi} \left(\frac{1}{\sqrt{A}} + \frac{1}{\sqrt{A}} + \frac{1}{\sqrt{2A}} \right) \quad (18)$$

and

$$N \Big|_{n=4} = \left(2 + \frac{1}{\sqrt{2}} \right) \frac{L_1}{\sqrt{A}} = 2.7 \frac{L_1}{\sqrt{A}}$$

For both conditions N was thus found practically equal. Now a relationship must be established between N and any intermediate number of rods from $n=4$ to $n=\infty$. The simplest expression which satisfies both limiting conditions and at the same time is in close agreement with published data for the resistance of multiple rod combinations is

$$N = \frac{2.74L_1}{\sqrt{A}} (\sqrt{n-1})^2 \quad \text{I(19)}$$

Equation I(19) can also be written as

$$N = (n-1) \frac{2.74L_1}{\sqrt{A}} \frac{\sqrt{n-1}}{\sqrt{n+1}} \quad \text{I(20)}$$

which offers some corollary to the preceding assumptions, if it is remembered that N represents the mutual influence of $(n-1)$ rods on the remaining one. For a rodbed as shown in Figure I-4, arranged in \sqrt{n} by \sqrt{n} rows, the spacing between adjoining rods is $\sqrt{A}/(\sqrt{n-1})$. If an average spacing s between any two of the n rods can be conceived, the potential induced on each rod by any one of $(n-1)$ rods would be $\rho I/2\pi ns$, with I =total current. Spacing s would then have to be the average of the $1/2 n(n-1)$ possible spacings and

$$s = \frac{\sqrt{A}}{\sqrt{n-1}} \frac{\sqrt{n+1}}{2.74}$$

would satisfy Equation I(19).

The arguments presented here, leading to a solution for a square rodbed, may be advanced for any other shape of the area. While the terms N for the plate and the four rods at corner points will not be in such close agreement as in Equations I(18) and I(19), the differences are small enough to be disregarded, particularly for larger numbers n . The numerical coefficients, for instance for a 1-to-4 rectangle, are 2.48 for the plate and 2.98 for the four corner rods, to replace 2.74 and 2.7 in Equations I(19) and I(18).

Equation I(19) generalized for any arbitrary shape or depth of the area may thus be written

$$N = \frac{2k_1 L_1}{\sqrt{A}} (\sqrt{n-1})^2 \quad \text{I(21)}$$

This equation entered in Equation I(16) produces the equation for the ground resistance of a rodbed.

APPENDIX II

DERIVATION OF CONDUCTIVITY
BY FOUR-POINT METHOD

DERIVATION OF CONDUCTIVITY
BY FOUR-POINT METHOD

A four-point array is shown in Figure 37 in which C_1 and C_2 are current terminals, and P_1 and P_2 are potential points. The distance s (See Figure 37b) corresponds to C_1P_1 and s' corresponds to C_2P_1 ; similarly, for C_1P_2 and C_2P_2 . The potential at point P_1 may then be given as

$$V_{P_1} = \frac{I}{2\pi\sigma} - \frac{1}{C_1P_1} - \frac{1}{C_2P_1} \quad \text{volts} \quad \text{II(1)}$$

$$V_{P_2} = \frac{I}{2\pi\sigma} - \frac{1}{C_1P_2} - \frac{1}{C_2P_2} \quad \text{volts} \quad \text{II(2)}$$

Distances are measured in meters.

The potential difference between points P_1 and P_2 is then:

$$V_{P_1} - V_{P_2} = V_{P_1P_2} = \frac{1}{2\pi\sigma} \left[\frac{1}{C_1P_1} + \frac{1}{C_2P_2} - \frac{1}{C_2P_1} - \frac{1}{C_1P_2} \right] \quad \text{volts} \quad \text{II(3)}$$

Since the ratio of the voltage appearing at terminals P_1P_2 to the current delivered by the current source is, effectively, a resistance and since these two quantities are measurable, we may obtain:

$$\frac{V_{P_1P_2}}{I} = R_o = \frac{1}{2\pi\sigma} \left[\frac{1}{C_1P_1} + \frac{1}{C_2P_2} - \frac{1}{C_2P_1} - \frac{1}{C_1P_2} \right] \quad \text{ohms} \quad \text{II(4)}$$

The earth conductivity, in terms of the above resistance and the distances between current and potential points, is then given by:

$$\sigma = \frac{1}{2\pi R_o} \left[\frac{1}{C_1P_1} + \frac{1}{C_2P_2} - \frac{1}{C_2P_1} - \frac{1}{C_1P_2} \right] \quad \text{mho-m/sq. m.}$$

APPENDIX III

DERIVATION FOR MAXIMUM RESISTANCE
OF SQUARE GRID MESH

DERIVATION FOR MAXIMUM RESISTANCE
OF SQUARE GRID MESH

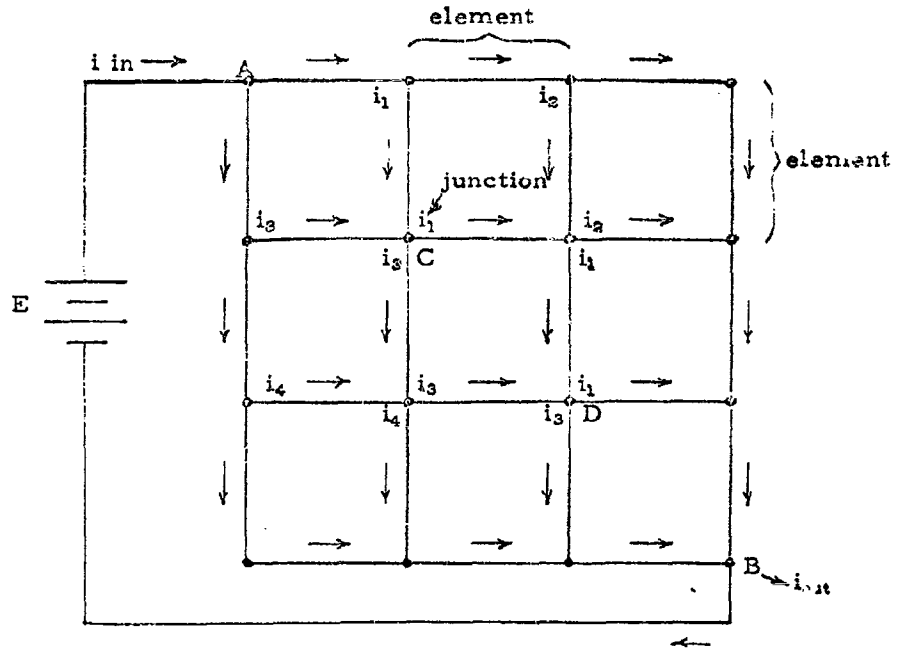

Figure III-1 GRID CONSTRUCTED OF THREE EVENLY-Spaced
GRIDS PER SIDE.

Figure III-1 shows a typical grid constructed of three grids per side ($n=3$) and a voltage source (E) which supplies current in the directions indicated. Assuming each element has equal resistance and that junction resistance is negligible the following statements can be made:

- (1) $i_1 = i_3$
- (2) $i_1 = i_2$
- (3) $i_3 = i_4$

Based on the above statements, the electrical diagram on Figure III-2 can be drawn.

The circuit of Figure III-2 can be broken down into two major parallel circuits, one on the right of the diagonal between A & B and one on the left as indicated in Figure III-3.

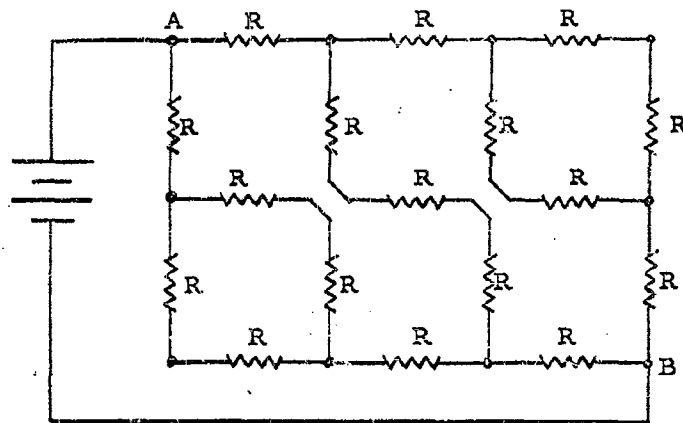

(a)

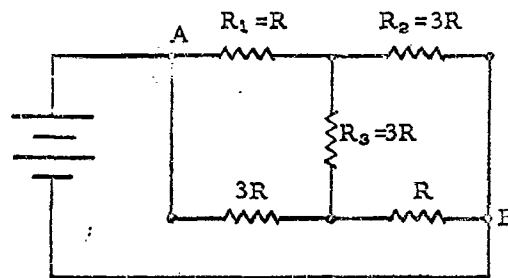

(b)

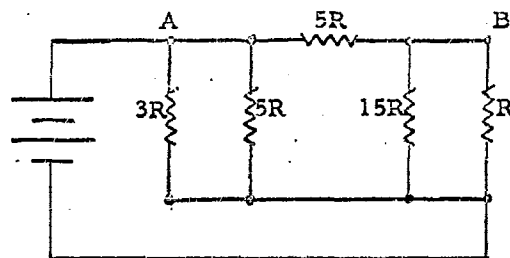

(c)

Figure IV-2 SCHEMATIC DIAGRAM OF RECTANGULAR GRID MESH.

The circuit of Figure III-3 can be easily solved for the resistance between points A and B as follows:

$$2R_{AB} = 2R + \frac{\left[2R + \frac{(2R)(2R)}{2R+2R} \right] (4R)}{2R + \frac{(2R)(2R)}{2R+2R} + 4R}$$

$$2R_{AB} = R \left(2 + \frac{12}{7} \right) \approx 3.71R$$

$$R_{AB} \approx \frac{3.71R}{2} \approx 1.86R \quad \text{III(1)}$$

∴ The resistance between points A & B for a mesh of 3 grids per side (n) is equal to 1.86 times the resistance of each element (R_s).

$$R_{AB} \quad n=3 = 1.86 R_s = kR_s \quad \text{III(2)}$$

The value of k has been computed for values of n through 30 and is shown in Table III(I).

Table III-I
 Computed Values of Coefficient "k"

n	2k	k
1	2	1
2	3	1.5
3	2 6/7	1.86
4	4.295	2.15
5	4.8	2.40
6	5.24	2.62
7	5.65	2.82
8	6.03	3.02
9	6.38	3.19
10	6.71	3.36
11	7.03	3.52
12	7.32	3.66
13	7.61	3.81
14	7.88	3.94
15	8.15	4.08
16	8.42	4.21
17	8.66	4.33
18	8.91	4.45
19	9.13	4.57
20	9.36	4.68
21	9.6	4.80
22	9.81	4.91
23	10.02	5.01
24	10.23	5.12
25	10.42	5.21
26	10.64	5.32
27	10.84	5.42
28	11.04	5.52
29	11.22	5.61
30	11.42	5.71

For constant lengths and widths the value of R_e will vary as the number of grids per side varies, or

$$R_e = \frac{R_e]_{n=1}}{n} \quad \text{III(3)}$$

$$\therefore R_{AB}]_n = k \frac{R_e]_{n=1}}{n} \quad \text{III(4)}$$

By observing computed values of "k" in Table III(1), it can be observed that " k "_n can be expressed in the following manner:

$$2k]_n = \left(\frac{2k]_{n-1} [2(n-1)]}{1 + 2(n-1)} + 2 \right) \quad \text{III(5)}$$

$$k]_n = \frac{1}{2} \left(\frac{2k]_{n-1} [2(n-1)]}{1 + 2(n-1)} + 2 \right)$$

$$\therefore R_{AB}]_n = \frac{R_e]_{n=1}}{2n} \left(\frac{2k]_{n-1} [2(n-1)]}{1 + 2(n-1)} + 2 \right) \quad \text{III(6)}$$

Values of $R_{AB}]_n$ have been computed from Equation III(6) and verified by using y-Δ transformations and also by simulating a grid of equal resistances and measuring the maximum resistance between points A and B.

APPENDIX IV

DERIVATION FOR MAXIMUM RESISTANCE
OF RECTANGULAR GRID MESH

DERIVATION FOR MAXIMUM RESISTANCE
OF RECTANGULAR GRID MESH

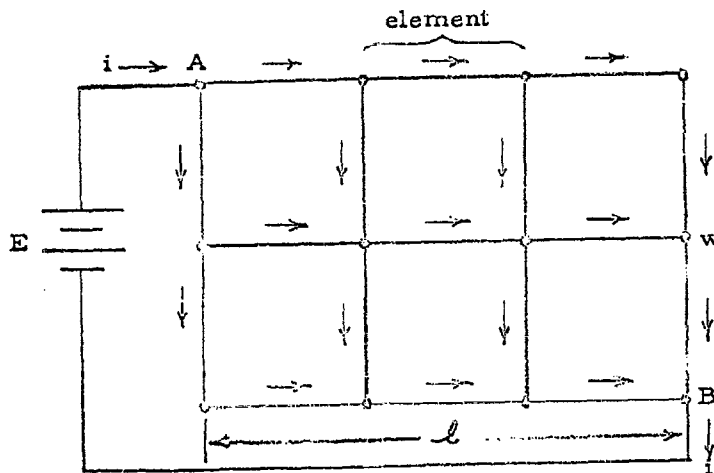

Figure IV-1 - TYPICAL RECTANGULAR GRID MESH.

Figure IV-1 illustrates a grid mesh with 3 grids along its length and 2 grids along its width ($n_l = 3$, $n_w = 2$). Assuming equal resistance elements, an equivalent circuit can be drawn as illustrated in Figure IV-2a. Figure IV-2a has been simplified by series parallel circuits to an equivalent form in IV-2b. A $y-\Delta$ transformation has been supplied to R_1 , R_2 and R_3 of Figure IV-2b to get the simplified circuit of Figure IV-2c. The simple series parallel circuit of Figure IV-2c has been solved for the resistance between points A & B, which is as follows:

$$R_{AB, n_l=3} = 1.796R \text{ (ohms)}$$

where

$$\begin{aligned} R &= \text{resistance of each element} \\ &= R_e \end{aligned}$$

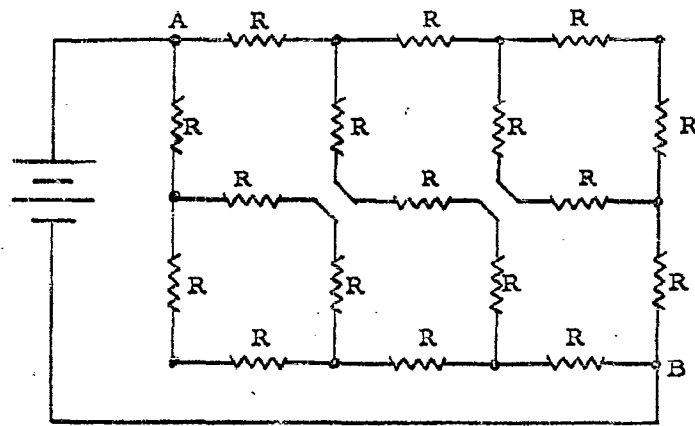

(a)

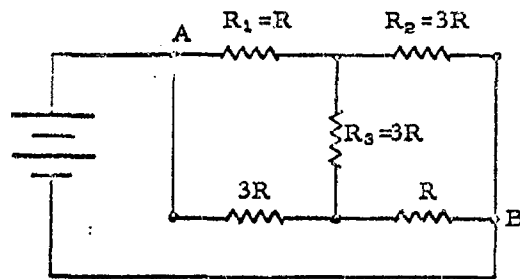

(b)

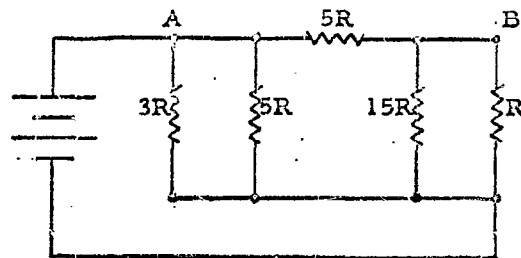

(c)

Figure IV-2 SCHEMATIC DIAGRAM OF RECTANGULAR GRID MESH.

The coefficient "k", which was obtained in Appendix III for a square grid mesh or two grids per side, was 1.5 (k = 1.5).

$$\begin{aligned} k_2 &= 1.798 - k = 1.798 - 1.5 \\ &= .298 \end{aligned} \quad \text{IV(2)}$$

where

k_2 = correction factor accounting for one more grid along length than along width.

The following expression describes the resistance between points A and B:

$$R_{AB} \Big|_{n_w=2} = \frac{R_{e_w} \Big|_{n=1}}{n_w} [k + k_2 (n_l - n_w)] \quad \text{IV(3)}$$

where

$R_{e_w} \Big|_{n=1}$ = resistance of one element of length equal to the width of the grid mesh.
 n_w = number of grids along width of mesh.
 n_l = number of grids along length of mesh.

For the case in question:

$$R_{AB} \Big|_{n_w=2} = \frac{R_{e_w} \Big|_{n=1}}{2} [1.5 + .298 (3-2)]$$

$$R_{AB} \Big|_{n_w=2} = .899 R_{e_w} \Big|_{n=1}$$

Equation IV(3) has been used to calculate R_{AB} for various length-to-width ratios, areas of coverage, and grids per side.

APPENDIX V
METALLIC WALLPAPER

Preliminary Technical Bulletin 11-2-9
Eccoshield WP-3SS - Metal Foil Wallpaper for RF Shielding

Eccoshield WP metal foil wallpaper may be installed on any exterior or interior structural surface which is reasonably smooth and flat.

For interior installation the general procedure should be as follows:

1. Remove from walls, ceiling and floor all protuberances and close off all openings not vital to proper functioning of the shielded enclosure. This will measurably reduce cutting, fitting and seam problems.
2. Set up a work area which allows the roll of Eccoshield WP-3SS to be unrolled horizontally and directly onto a cutting board. The cutting board should be at least as long as the height of the room.
3. Cut sufficient strips to cover all wall area allowing one inch for vertical seam overlap. Allow at least an extra inch in length at top and bottom for overlap to ceiling and floor covering.
4. Apply Eccobond WP-YG adhesive with a notched tooth applicator to the wall area for the first strip of Eccoshield WP-3SS. The Eccoshield WP-3SS may be applied immediately. Do not give the Eccobond WP-YG more than 1/2 hour open time. It should be wet to allow proper transfer of the adhesive to the foil. The foil can be displaced laterally within 1/2 hour if realignment is necessary.
5. Planish the foil surface with a weighted cloth to insure contact and to remove wrinkles.
6. Apply a bead of Eccoshield VY conductive sealer within 1/2" of the edge of the foil at the place of overlap of the second sheet. Emerson & Cuming, Inc. 30cc plastic syringe produces a bead of appropriate weight.
7. Apply the second sheet in the same manner allowing one inch overlap to the first sheet. With a standard staple gun staple through the overlap on each side of the captive Eccoshield VY bead. Staple the entire seam keeping each pair of staples not more than three inches apart. Be sure the Eccoshield VY bead is continuous and that the staples insure intimate contact of both pieces of foil to the bead. On surfaces which will not accept staples, batten strips 1-1/2" wide by 1/4" thick may be used over the overlap and secured with screws, nails or adhesive.
8. Continue as above until all wall surfaces are covered making cut-outs as required for windows, vents, doors, etc. Cut-outs should be smaller than openings so that the Eccoshield WP-3SS can be folded around door jambs window casings, etc.

9. Apply the Eccoshield WP-3SS to the ceiling and floor in the same manner being sure to allow overlap to the wall strips.

SPECIAL NOTES:

Doors

The door should be covered in the same manner as the walls allowing complete coverage of all four edges. In case of panel doors it may be necessary to apply plywood to the face. Nail Eccoshield WS-RS RF weatherstrip to the top, bottom and hinge edges of the door and to the latch side of the door jamb. Be sure to check door clearance before starting to insure proper contact at all points where the door is closed. If shimming is required it should be applied under the foil and not between the shield strip and foil.

Windows, Vents, etc.

Cut Eccoshield SC-1014 RF Screening at least three inches larger in each dimension than the opening to be treated. Apply two or three beads of Eccoshield VY to the foil around the opening then set the screening over the opening forcing the overlap into the beads. Secure with staples and then batten strips.

Electrical Outlets, Switches, etc.

Electrical filters should, of course, be used on all incoming lines. All wiring should then be preferably within the shield.

Final Inspection

Inspect installation carefully for faulty seams, untreated areas, etc. Use Eccoshield VY to caulk minor cracks and voids. Use Eccoshield WP-3SS and Eccoshield VY to seal larger areas. The key to RF integrity is that the shield be completely continuous. Seams, joints, windows, doors and penetrations are the major source of leakage.

Redecoration

When all surfaces, doors, windows, etc., have been treated the interior may be redecorated using conventional materials such as paint, ceiling tiles, wallboard, decorative wall panels, floor tiles, etc. Limited use of small nails through the shielding can be tolerated; however, adhesive bonding of decorative materials with Eccobond WP-YG is preferred. Do not paint door jambs or Eccoshield WS-RS RF weatherstrip as electrical contact is essential.

Exterior Installation

Eccoshield WP-3SS may be applied to the exterior of structures in less critical RF shielding applications. Inability to apply foil under the floor will result in some reduction of RF shielding effectiveness. The procedure

for application is exactly the same as for interior surfaces. A preferred procedure is to run the exterior Eccoshield WP-3SS into the ground to a depth of about 6 inches. Batten strips over the seams which can be caulked with standard weatherproofing mastic is generally preferred to stapling. In cases where roof construction utilizes rough materials such as shingles or gravel it is recommended that plywood sheathing be used as an underlayment for the Eccoshield WP-3SS. When installation is complete Eccoshield WP-3SS can be painted. This, however, is not necessary.

Preliminary Technical Bulletin 11-2-9
Eccoshield WP

Eccoshield WP is a group of specially developed metal foils which are used in radio frequency shielding applications. The materials may be used to construct shielded chambers of thousands of square feet in surface area or for small equipment enclosures; they may be used on new construction or to make existing unshielded rooms into high performance R. F. Shielded areas. Eccoshield WP is used in conjunction with other Eccoshield products, such as conductive adhesives, surface coatings and caulking compounds to produce enclosures which have insertion loss for electric fields and plane waves in excess of 100 db from 200 kc to 35 kmc. Magnetic field insertion loss is also high. Construction of a shielded area using Eccoshield WP is much less expensive in both materials and labor than conventional screen rooms; moreover, Eccoshield WP Shielded Rooms are often more effective from an R. F. standpoint because the joint problem is essentially eliminated. Completed structures are maintenance-free since corrosion and loosening of joints is almost impossible.

Eccoshield WP is installed like wallpaper. It covers walls, ceiling and floor. It is stapled or bonded with Eccobond epoxy adhesives to understructure. Understructure can be wood, plaster, concrete, metal, etc. A minimum of site preparation is needed. Adjacent sheets of Eccoshield WP are generously overlapped. The overlap contains a bead of conductive adhesive (Eccobond 70C) or conductive caulking compound (Eccoshield VX or VY). This produces a perfect continuous and corrosion-free R. F. seal. Soldering or welding of Eccoshield WP joints is not recommended; it is expensive, hazardous and unreliable. Decorative materials can be readily applied to interior surfaces of Eccoshield WP to provide attractive work areas. These materials include floor tile, acoustical tile, plywood panelling, paint, etc.

Air vents are provided in Eccoshield WP rooms by the use of screening, honeycomb vent (Eccoshield HV) or metal foam (Eccofoam MD). Bonding is accomplished with conductive adhesives. Incoming power lines are filtered in the conventional manner. Doors and frames are preferably of the Eccoshield SD type. However, low cost, R.F. tight doors have been made by using a flat wooden door sheathed with Eccoshield WP and using knitted metal gaskets (Eccoshield MX) or conductive plastic gaskets (Eccoshield SV) for the seal.

Eccoshield WP-3SS

This is the preferred material for shielded room use. It is a special stainless steel of both high conductivity and high permeability. High conductivity assures good electric field shielding; high permeability assures good magnetic field shielding. It will not corrode even under the most severe outdoor exposure. Thickness is 3 mils, the optimum in shielding effectiveness and handleability.

Eccoshield WP-3CU

This is 3 mil copper foil specifically designed for shielded room use. It can be bonded readily with adhesives, and has good handleability. Conductivity is extremely high; for electric field shielding it is excellent. It is low in cost.

Eccoshield WP-4MM

This is intended primarily for low frequency magnetic field shielding. It has extremely high permeability. Offered in 4 mil thickness, it is recommended for small magnetically shielded rooms or as a component shield. It can readily be fabricated into tubes, cans, boxes, etc. It has been used effectively to line equipment cabinets.

SHIELDING EFFECTIVENESS

		Insertion Loss In Accordance with MIL STD 285		
<u>Frequency</u>		<u>Eccoshield WP-3SS</u>	<u>Eccoshield WP-3CU</u>	<u>Eccoshield WP-4MM</u>
200 KC	Magnetic Field	60 db	40 db	60 db
	Electric Field	>100 db	>100 db	>100 db
1 Mc	Electric Field	>100 db	>100 db	>100 db
10 Mc	Electric Field	>100 db	>100 db	>100 db
400 Mc	Plane Wave	>100 db	>100 db	>100 db
9.375 Gc	Plane Wave	>100 db	>100 db	>100 db

Shielding efficiency data on Eccoshield WP-4MM is presented below. With constant input voltage, output voltage is measured with no shielding material and then with Eccoshield WO-4MM.

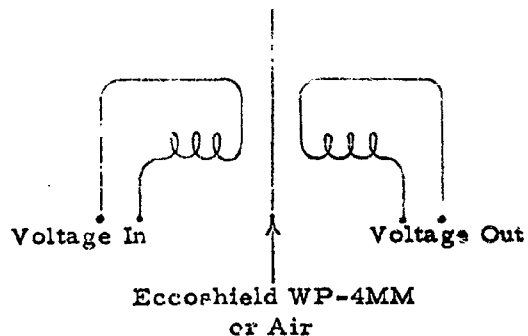

% Shielding Efficiency = 100

$$\% \text{ Shielding Efficiency} = \frac{\text{Voltage Out (Eccoshield WP-4MM)}}{\text{Voltage Out (Air)}} \times 100$$

Frequency	% Shielding Efficiency
60 cps	98
100 cps	97
1 Kc	99
10 Kc	98

Completely enclosed structures for attenuation of dc and very-low-frequency ac fields have to be constructed with inter-folded seams to minimize magnetic reluctance between mating sheets of foil. In instances where the calibration of sensitive magnetic detectors, for example, requires attenuation of the earth's magnetic field, a single layer of Eccoshield WP-4MM will provide 12 to 15 db ratio between magnetic field strengths inside and outside the enclosure. A double or triple shield with substantial spacing between the layers of Eccoshield WP-4MM will assure much greater isolation.