

UNCLASSIFIED

AD 414382

DEFENSE DOCUMENTATION CENTER

FOR

SCIENTIFIC AND TECHNICAL INFORMATION

CAMERON STATION, ALEXANDRIA, VIRGINIA



UNCLASSIFIED

NOTICE: When government or other drawings, specifications or other data are used for any purpose other than in connection with a definitely related government procurement operation, the U. S. Government thereby incurs no responsibility, nor any obligation whatsoever; and the fact that the Government may have formulated, furnished, or in any way supplied the said drawings, specifications, or other data is not to be regarded by implication or otherwise as in any manner licensing the holder or any other person or corporation, or conveying any rights or permission to manufacture, use or sell any patented invention that may in any way be related thereto.

PROGRESS REPORT NO. 3

ON

CONTRACT NObs-88181

1 APRIL - 30 JUNE 1963

18 July 1963

Copy No. 10

414382

DEFENSE RESEARCH LABORATORY

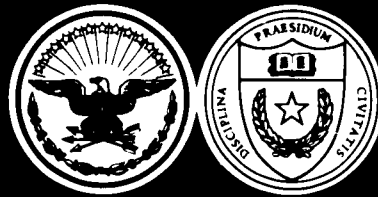

THE UNIVERSITY OF TEXAS · AUSTIN 12, TEXAS

PROGRESS REPORT NO. 3

ON

CONTRACT NObs-88181

1 APRIL - 30 JUNE 1963

18 July 1963

Copy No. 10

Sponsor: Department of the Navy, Bureau of Ships
Applied Research Division Ship Silencing Branch

Project S-F-013-11-01, Task 1359

DEFENSE RESEARCH LABORATORY
THE UNIVERSITY OF TEXAS
AUSTIN 12, TEXAS

ABSTRACT

A special purpose electronic analog computer has been built. A preliminary trial of the computer brought attention to several minor circuit difficulties such as inaccuracy of frequency tracking, and noise and crosstalk between two similar information channels. Changes have been made to render some of these defects less serious. A ± 10 dB reduction of the dynamic range limitation imposed by combined noise and crosstalk has been realized. Additional improvements are being considered. Mechanical impedances of a previously studied structure were measured, using the computer. Comparison of the results with data obtained earlier shows good agreement although the frequency tracking error is in evidence. The automatic computing system resolved features of the impedance characteristics of the system that were previously overlooked.

Defense Research Laboratory is scheduled to participate in a program of mechanical impedance measurements being conducted by the U. S. Naval Research Laboratory, Washington, D. C. Very little time will be required for this work and the measurements to be made will provide a test of the recently completed computer and a comparison of four mechanical impedance heads presently on hand.

TABLE OF CONTENTS

	<u>Page</u>
ABSTRACT	ii
I. ADMINISTRATION	1
A. Introduction	1
B. Research Staff	2
II. SUMMARY OF TECHNICAL WORK	3
A. Introduction	3
B. Automatic Impedance Computer	4
C. Mechanical Impedance "Round Robin"	7

18 July 1963
JVK:ad

PROGRESS REPORT NO. 3

ON

CONTRACT NObs-88181

I. ADMINISTRATION

A. Introduction

This report covers technical work performed under Contract NObs-88181 during the months of April, May, and June, 1963.

A proposal to continue and extend the technical program being pursued under Contract NObs-88181 for another year was submitted to Bureau of Ships on 26 April 1963.

Dr. E. L. Hixson attended the meeting of the Acoustical Society of America in New York 16-18 May 1963. On the same trip he attended the Ship Silencing Symposium held 20-22 May in New London, Connecticut, where he presented a paper entitled, "Transmissibility of Some Pipe Vibration Isolators."

On 6 June 1963 Dr. C. M. McKinney visited Bureau of Ships, Code 345, and conferred with Dr. R. M. Sherwood and Mr. F. R. Lewis on technical work being performed under this contract and the outlook for continuing the work under Bureau of Ships sponsorship.

18 July 1963
JVK:ba

B. Research Staff

<u>Name</u>	<u>Degree</u>	<u>Position</u>	<u>Time</u>
Cousins, E. L.	B.S.	Research Engineer	1.00
Hixon, E. L.	Ph.D.	Research Engineer	.38*
Kahlbau, J. V.	M.S.	Supervisor, Noise and Vibration Section	1.00
McKinney, C. M.	Ph.D.	Head, Acoustics Division	.05

* Increased time to .75 on 1 June 1963

18 July 1963
JVK:ad

II. SUMMARY OF TECHNICAL WORK

A. Introduction

The projects undertaken for the current contract year are (1) a program of acoustic impedance measurements on water-filled pipe fittings, a pump, acoustic filter branch elements, and a typical filter load; (2) the design, construction, and testing of an electronic analog device for automatically computing acoustical and mechanical impedances from transducer signals. Since the point-by-point impedance measuring technique which has been used heretofore is so time-consuming, some of the rather extensive measurements on pipe fittings, etc., have been deferred in favor of completing the automatic computer. The computer promises to reduce time spent in making impedance measurements considerably and with this improvement in prospect it seemed wise to place major emphasis on its completion.

Defense Research Laboratory is scheduled to participate in a mechanical impedance measurement program being conducted by the U. S. Naval Research Laboratory.

18 July 1963
JVK:ad

B. Automatic Impedance Computer

Construction of the electronic analog equipment for processing appropriate transducer signals to obtain impedance, magnitude, and angle for either mechanical or acoustical systems is essentially finished. There remain a number of mechanical and electrical circuit details to be finished or modified; however, the equipment has been tried and found to function rather well. Certain aspects of the behavior of particular circuits and the overall performance of the equipment based on experience to date are discussed in succeeding paragraphs.

The units of the computer are shown in Photo. 88181-10. They are (1) the main rack, housing a control chassis, preamplifiers for two information channels, a power amplifier and power supply, (2) a beat frequency oscillator, and (3) a phase meter and an x-y plotter. The plotter was borrowed from a different technical group within this Laboratory. A block diagram of the computer and most of the circuit details have already been reported.¹ Two circuits which have not been reported are the phase meter amplifier, Dwg. AS-8100, and the ac to dc converter, Dwg. AS-8101. These circuits are built on the control chassis. Operating characteristics of the converter over the input voltage range 0.01 to 0.5 V rms are shown by the curve of Dwg. AS-8102.

In the initial trial of the computer it was set up and calibrated to measure mechanical impedance of a pipe-mass load, Photo. 86165-8. The impedance of this structure had previously been measured point-by-point fashion. Some of the computer subassemblies did not work properly at first; numerous adjustments and a few minor circuit changes were made in getting into the operation. These difficulties fell into three categories, (1) inaccuracy of the dc voltage from the oscillator representing the logarithm of frequency, (2) objectionably high noise level and crosstalk between information channels,

¹Quarterly Progress Report No. 1 on Contract NObs-88181, Defense Research Laboratory, The University of Texas, 1 October-31 December, 1962, p. 4.

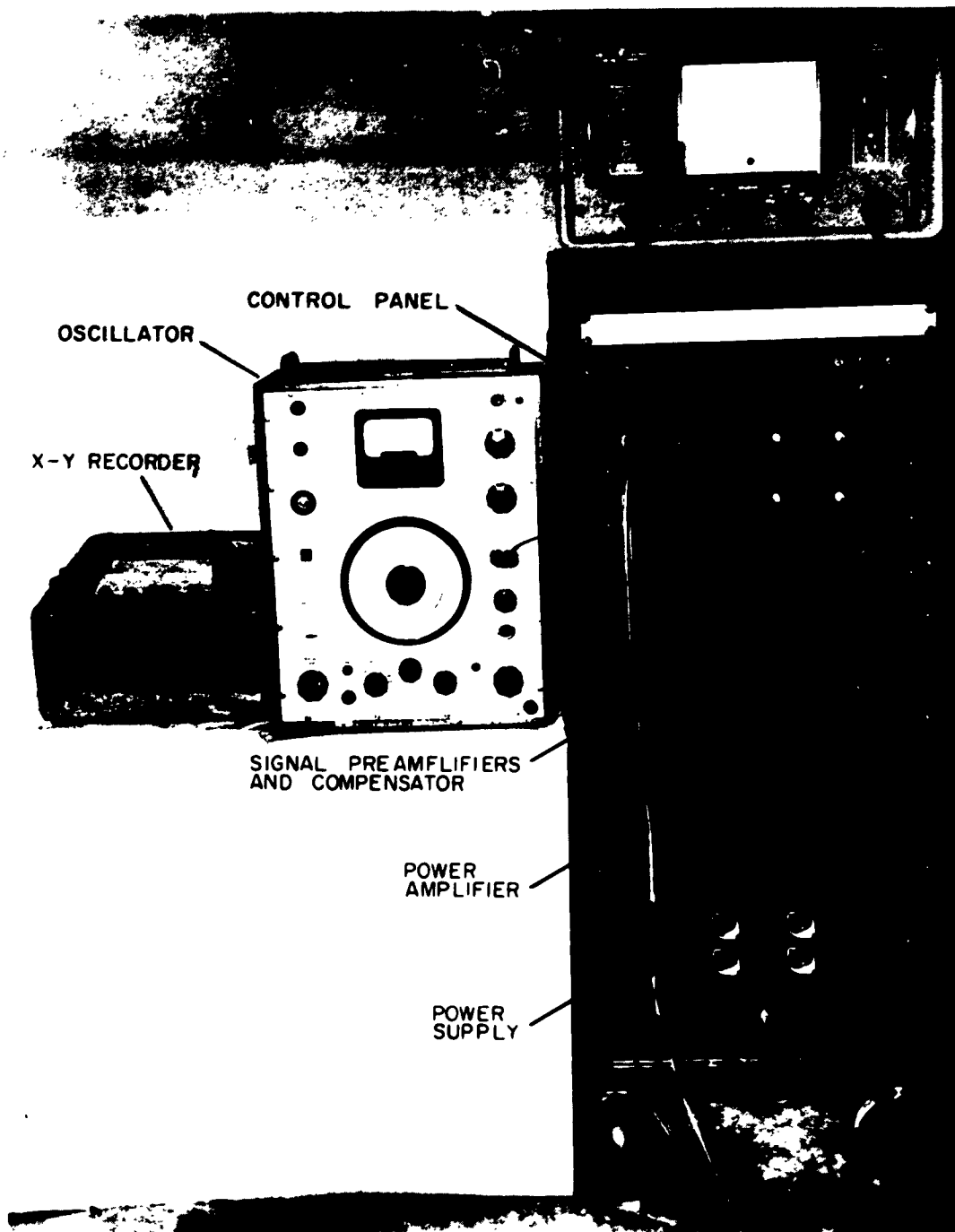

AUTOMATIC IMPEDANCE COMPUTER

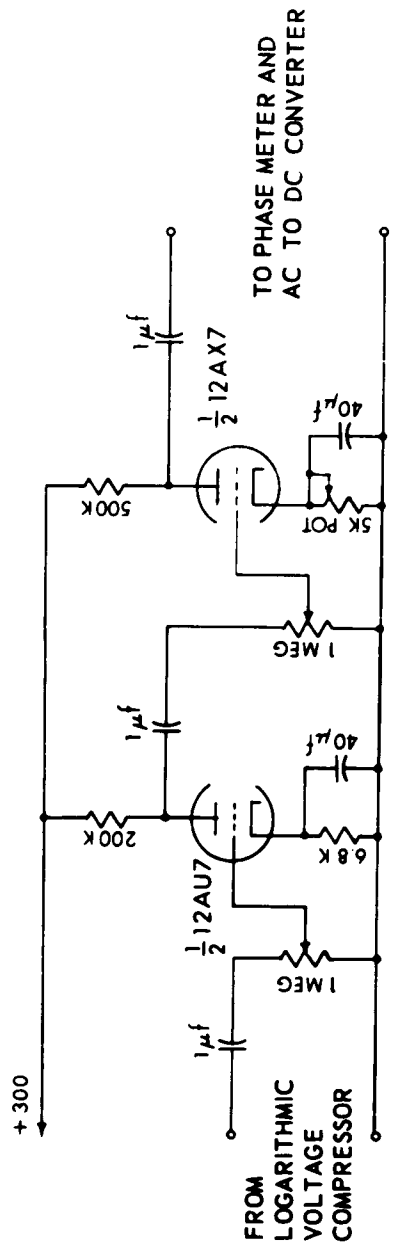

PHASE METER AMPLIFIER
(TWO REQUIRED)

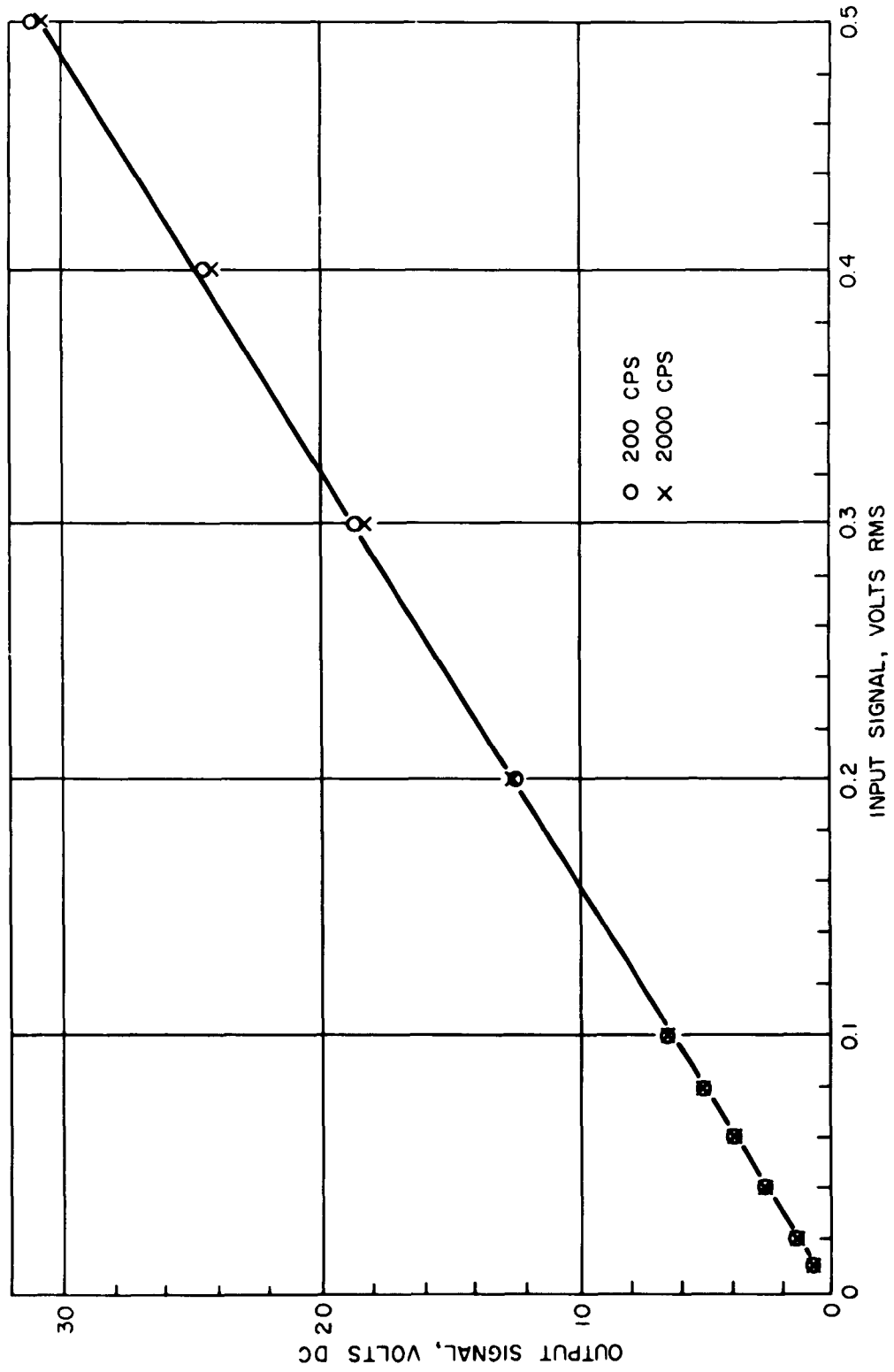

DRL - UT
 DWG AS 8102
 JVK - LFH
 7 - 3 - 63

AC TO DC CONVERTER CHARACTERISTICS

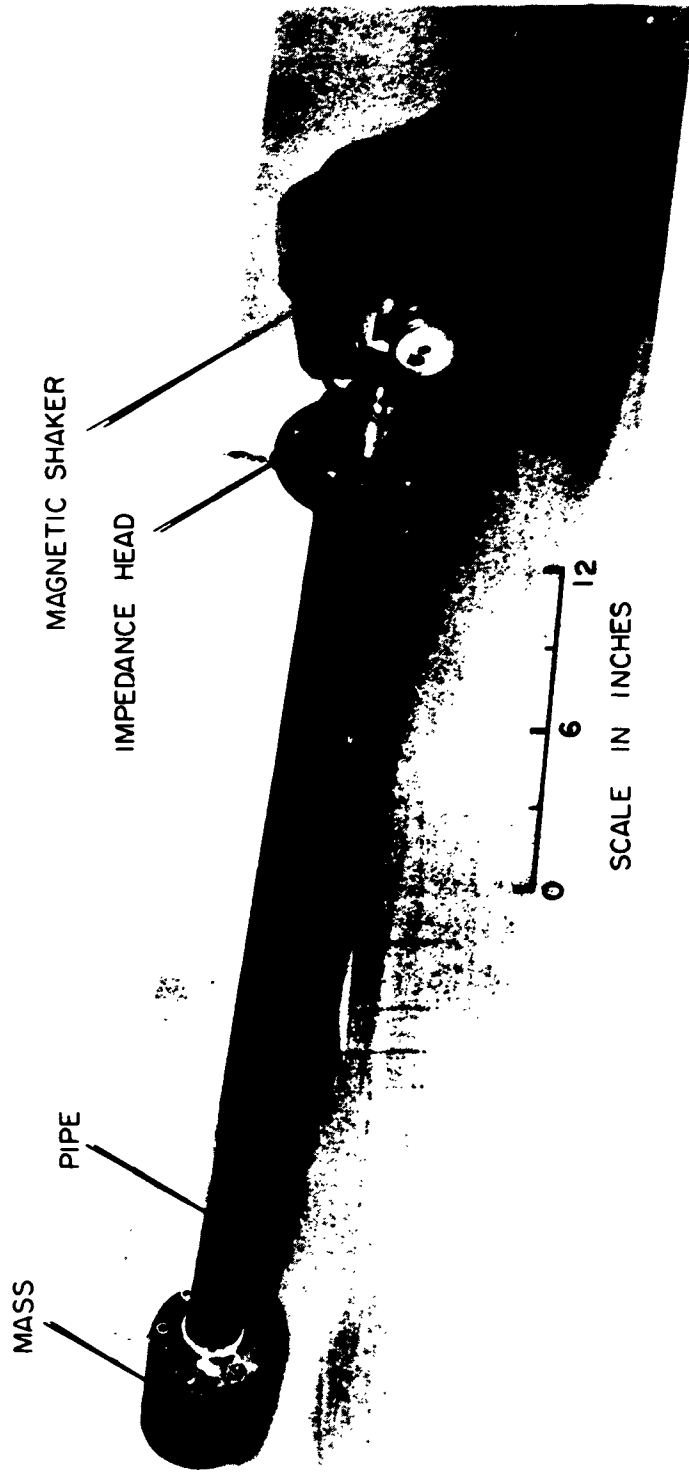

SETUP FOR MEASURING THE IMPEDANCE OF A PIPE AND MASS SYSTEM

18 July 1963
JVK:ad

and (3) instability of the amplifiers preceding the logarithmic compressor units. The frequency error was minimized by carefully adjusting angular position between the oscillator shaft and the shaft of the nonlinear mechanical drive. There still persists, however, some frequency error, presumably due to deviation of the oscillator characteristics from those specified, drift caused by component temperature changes, etc. In its present condition the oscillator unit operates at frequencies differing by as much as 6% from those indicated by the dc voltage supplied to the plotter frequency axis. Further improvement may require use of a different oscillator or construction of a more elaborate mechanical drive unit. The high noise level, crosstalk, and instability were all traced to the amplifiers immediately preceding the logarithmic compressors. The first two effects were reduced by rearranging wiring to reduce stray capacitance. At present, noise and cross coupling limit the dynamic range of ratio measurements of signals through these amplifiers to about ± 50 dB, whereas before reworking the leads, only a ± 40 dB range could be covered. It may be possible to make further improvement by providing vacuum tubes in separate envelopes in place of the 12AX7 and 6SN7 now common to both channels. Instability of these amplifiers was eliminated by raising the potential of both tubes 150 V, i.e., returning the cathodes to ground rather than -150 V and raising the plate potentials from +350 V to +500 V.

After these improvements were made, impedance magnitude of the pipe-mass load was measured and plotted automatically. On Dwg. AS-8103, the results are compared with previously measured values for the same structure. The agreement is remarkably good insofar as the overall character of the two curves is concerned, although indicated critical frequencies differ markedly in some cases. Also, it can be seen that the computer with its continuous plotting feature resolved a number of effects overlooked in collecting the earlier data. Impedance angle measurements were also attempted; the automatically plotted curve that was obtained indicated drift and non-linearity in the phase meter isolation circuit. This has not yet been corrected, but it is believed that comparatively minor circuit modifications will improve the angle measuring capability of the equipment.

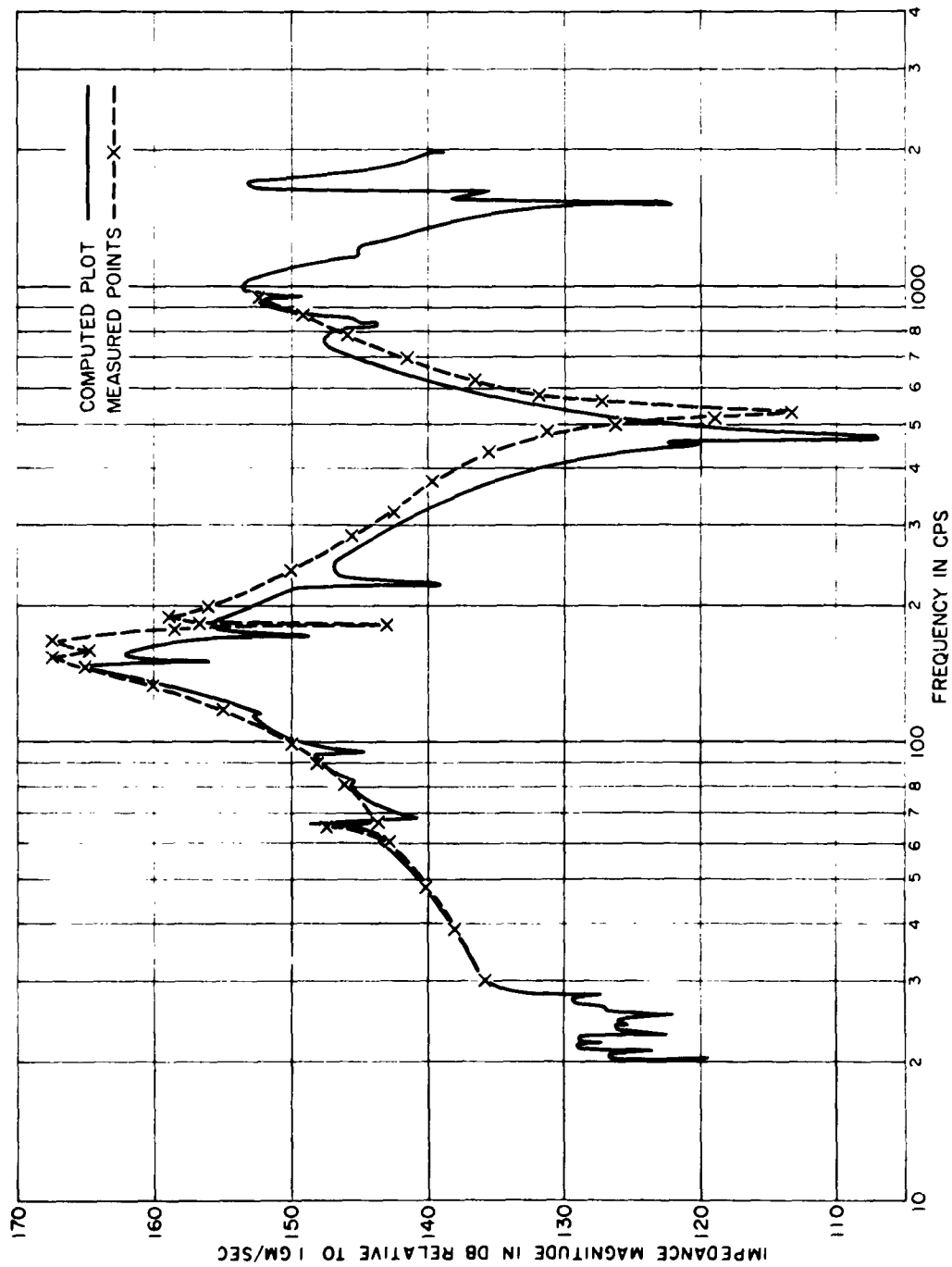

MEASURED AND MACHINE COMPUTED VALUES OF
MECHANICAL IMPEDANCE OF PIPE-MASS SYSTEM

DRL - UT
DWG AS 8103
JVK, EJW
7 3 - 63

18 July 1963
JVK:ad

It is foreseen that after some of the needed improvements are made and experience in using this computer is gained, availability of this equipment will dramatically reduce the time spent in making measurements. The frequency interval 20-2000 cps is swept in approximately 12 minutes by the motor driven oscillator so it should be easy to obtain in half an hour the information that would formerly have consumed an afternoon to collect and reduce.

C. Mechanical Impedance "Round Robin"

The Technical Committee on Shock and Vibration of the Acoustical Society of America has initiated a mechanical impedance measurement comparison program. This Mechanical Impedance "Round Robin" is being conducted by the U. S. Naval Research Laboratory, Washington, D. C.; the program is under the direction of R. O. Belsheim and G. M. Remmers. The purpose of the program is to determine the comparability of mechanical impedance measurements made on the same structure by different laboratories. Defense Research Laboratory has accepted an invitation to participate.

Three structures have been built which place different demands on the instrumentation. No specific information on each structure has been supplied beforehand, but support and attachment conditions have been specified. Each laboratory will have about one week to perform the measurements. Participants have been urged to make the measurements by their usual methods and to report all results whether they are considered "good data" or not.

Measurements can be made at this Laboratory with four different mechanical impedance transducers. The first of these² was built at DRL for use with lightweight structures. The second and third were built and furnished by the David Taylor Model Basin. One is suitable for the measurement of very large magnitude impedances and the other is better suited for use on less massive structures. The fourth impedance transducer was supplied as a gift to The University of Texas by the Endevco Company. It is their Model 2110, which is supposed to accommodate a wide range of impedance magnitudes.

Very little preparation has been required for the impedance measurements. A supporting hanger for the structures will be supplied by Naval Research Laboratory. Since the transducer attachment has been specified, steel adaptors have been made so that each impedance transducer can be attached

²Quarterly Progress Report No. 10 on Contract NObs-77033, 21 April 1959

18 July 1963
ELH:ad

and the system excited by a 10-lb force vibration generator. Although the time schedule is limited, it is hoped that each of the three structures can be measured with each transducer. It is hoped that measurements can be made using the impedance computer-plotter and repeated by the point-by-point method.

The "Round Robin" impedance measurement program should be a good indication of the "state of the art" in this class of measurements. This program comes at an opportune time for Defense Research Laboratory. The measurements will allow a comparison of the several available transducers under closely controlled conditions and a comparison of the data taken with the recently constructed Impedance Computer with data taken by formerly used methods.

DISTRIBUTION LIST

Copy No.

1 - 3	Chief, Bureau of Ships Department of the Navy Washington 25, D. C. Attn: Code 335
4 - 5 and 1 Reproducible	Chief, Bureau of Ships Department of the Navy Washington 25, D. C. Attn: Code 345
6	Chief, Bureau of Ships Department of the Navy Washington 25, D. C. Attn: Code 434
7	Chief, Bureau of Ships Department of the Navy Washington 25, D. C. Attn: Code 648
8	Chief, Bureau of Ships Department of the Navy Washington 25, D. C. Attn: Code 649
9 - 18	Defense Documentation Center Cameron Station, Building #5 5010 Duke Street Alexandria 4, Virginia
19	U. S. Naval Engineering Experiment Station Annapolis, Maryland Attn: Code 824
20	David Taylor Model Basin Carderock, Maryland Attn: Code 564
21	Commander Portsmouth Naval Shipyard Portsmouth, New Hampshire Attn: Code 251
22	Commander Mare Island Naval Shipyard (Rubber Laboratory) Vallejo, California

DISTRIBUTION LIST (Cont'd)

<u>Copy No.</u>	
23	Electric Boat Division General Dynamics Corporation Research and Development Laboratory Groton, Connecticut
24	Newport News Shipbuilding and Drydock Company Engineering and Research Laboratory Newport News, Virginia
25	Chief, Office of Naval Research Washington, D. C. Attn: Code 411
26	Mr. F. M. Lucas Special Representative Office of Naval Research 2506 Main Building The University of Texas Austin 12, Texas
27	Director, DRL/UT
28	C. M. McKinney, DRL/UT
29	E. L. Hixson, DRL/UT
30	J. V. Kahlbau, DRL/UT
31 - 32	Library, DRL/UT

<p>Defense Research Laboratory, The University of Texas, Austin, Texas PROGRESS REPORT NO. 3 ON CONTRACT NObs-88181, 1 APRIL--30 JUNE 1963, by J. V. Kahlbau and E. L. Hixson. 30 June 1963, 19 p. incl. illus. Unclassified report (Contract NObs-88181)</p> <p>Completion of an electronic analog computing unit to facilitate measuring and plotting acoustical and mechanical impedances is reported. Performance of the equipment in preliminary tests and suggested improvements are discussed. Comparing curves obtained by computer and point-by-point methods for a particular mechanical system showed that the computer duplicated salient features of the previously measured impedance characteristics. A frequency tracking error was noted but it is believed to be attributable to calibration inaccuracy of the oscillator incorporated in the equipment. It is further reported that Defense Research Laboratory plans to participate in a "round robin" mechanical impedance measuring program being conducted by the Naval Research Laboratory.</p>	<p style="text-align: center;">UNCLASSIFIED</p> <ol style="list-style-type: none"> 1. Impedance, Acoustical and Mechanical 2. Mechanical Impedance Measurement I. Kahlbau, J. V. II. Hixson, E. L. III. Contract NObs-88181 <p style="text-align: center;">UNCLASSIFIED</p>
<p>Defense Research Laboratory, The University of Texas, Austin, Texas PROGRESS REPORT NO. 3 ON CONTRACT NObs-88181, 1 APRIL--30 JUNE 1963, by J. V. Kahlbau and E. L. Hixson. 30 June 1963, 19 p. incl. illus. Unclassified report (Contract NObs-88181)</p> <p>Completion of an electronic analog computing unit to facilitate measuring and plotting acoustical and mechanical impedances is reported. Performance of the equipment in preliminary tests and suggested improvements are discussed. Comparing curves obtained by computer and point-by-point methods for a particular mechanical system showed that the computer duplicated salient features of the previously measured impedance characteristics. A frequency tracking error was noted but it is believed to be attributable to calibration inaccuracy of the oscillator incorporated in the equipment. It is further reported that Defense Research Laboratory plans to participate in a "round robin" mechanical impedance measuring program being conducted by the Naval Research Laboratory.</p>	<p style="text-align: center;">UNCLASSIFIED</p> <ol style="list-style-type: none"> 1. Impedance, Acoustical and Mechanical 2. Mechanical Impedance Measurement I. Kahlbau, J. V. II. Hixson, E. L. III. Contract NObs-88181 <p style="text-align: center;">UNCLASSIFIED</p>

<p>Defense Research Laboratory, The University of Texas, Austin, Texas PROGRESS REPORT NO. 3 ON CONTRACT NObs-88181, 1 APRIL--30 JUNE 1963, by J. V. Kahlbau and E. L. Hixson. 30 June 1963, 19 p. incl. illus. Unclassified report (Contract NObs-88181)</p> <p>Completion of an electronic analog computing unit to facilitate measuring and plotting acoustical and mechanical impedances is reported. Performance of the equipment in preliminary tests and suggested improvements are discussed. Comparing curves obtained by computer and point-by-point methods for a particular mechanical system showed that the computer duplicated salient features of the previously measured impedance characteristics. A frequency tracking error was noted but it is believed to be attributable to calibration inaccuracy of the oscillator incorporated in the equipment. It is further reported that Defense Research Laboratory plans to participate in a "round robin" mechanical impedance measuring program being conducted by the Naval Research Laboratory.</p>	<p style="text-align: center;">UNCLASSIFIED</p> <ol style="list-style-type: none"> 1. Impedance, Acoustical and Mechanical 2. Mechanical Impedance Measurement I. Kahlbau, J. V. II. Hixson, E. L. III. Contract NObs-88181 <p style="text-align: center;">UNCLASSIFIED</p>
<p>Defense Research Laboratory, The University of Texas, Austin, Texas PROGRESS REPORT NO. 3 ON CONTRACT NObs-88181, 1 APRIL--30 JUNE 1963, by J. V. Kahlbau and E. L. Hixson. 30 June 1963, 19 p. incl. illus. Unclassified report (Contract NObs-88181)</p> <p>Completion of an electronic analog computing unit to facilitate measuring and plotting acoustical and mechanical impedances is reported. Performance of the equipment in preliminary tests and suggested improvements are discussed. Comparing curves obtained by computer and point-by-point methods for a particular mechanical system showed that the computer duplicated salient features of the previously measured impedance characteristics. A frequency tracking error was noted but it is believed to be attributable to calibration inaccuracy of the oscillator incorporated in the equipment. It is further reported that Defense Research Laboratory plans to participate in a "round robin" mechanical impedance measuring program being conducted by the Naval Research Laboratory.</p>	<p style="text-align: center;">UNCLASSIFIED</p> <ol style="list-style-type: none"> 1. Impedance, Acoustical and Mechanical 2. Mechanical Impedance Measurement I. Kahlbau, J. V. II. Hixson, E. L. III. Contract NObs-88181 <p style="text-align: center;">UNCLASSIFIED</p>

<p style="text-align: center;">UNCLASSIFIED</p>	<p style="text-align: center;">UNCLASSIFIED</p>	<p style="text-align: center;">UNCLASSIFIED</p>
<p style="text-align: center;">UNCLASSIFIED</p>	<p style="text-align: center;">UNCLASSIFIED</p>	<p style="text-align: center;">UNCLASSIFIED</p>
<p style="text-align: center;">UNCLASSIFIED</p>	<p style="text-align: center;">UNCLASSIFIED</p>	<p style="text-align: center;">UNCLASSIFIED</p>
<p style="text-align: center;">UNCLASSIFIED</p>	<p style="text-align: center;">UNCLASSIFIED</p>	<p style="text-align: center;">UNCLASSIFIED</p>
<p style="text-align: center;">UNCLASSIFIED</p>	<p style="text-align: center;">UNCLASSIFIED</p>	<p style="text-align: center;">UNCLASSIFIED</p>

<p style="text-align: center;">UNCLASSIFIED</p>	<p style="text-align: center;">UNCLASSIFIED</p>	<p style="text-align: center;">UNCLASSIFIED</p>
<p style="text-align: center;">UNCLASSIFIED</p>	<p style="text-align: center;">UNCLASSIFIED</p>	<p style="text-align: center;">UNCLASSIFIED</p>
<p style="text-align: center;">UNCLASSIFIED</p>	<p style="text-align: center;">UNCLASSIFIED</p>	<p style="text-align: center;">UNCLASSIFIED</p>
<p style="text-align: center;">UNCLASSIFIED</p>	<p style="text-align: center;">UNCLASSIFIED</p>	<p style="text-align: center;">UNCLASSIFIED</p>
<p style="text-align: center;">UNCLASSIFIED</p>	<p style="text-align: center;">UNCLASSIFIED</p>	<p style="text-align: center;">UNCLASSIFIED</p>