

UNCLASSIFIED

AD

4 2 0 8 1 4

DEFENSE DOCUMENTATION CENTER

FOR

SCIENTIFIC AND TECHNICAL INFORMATION

CAMERON STATION, ALEXANDRIA, VIRGINIA



UNCLASSIFIED

NOTICE: When government or other drawings, specifications or other data are used for any purpose other than in connection with a definitely related government procurement operation, the U. S. Government thereby incurs no responsibility, nor any obligation whatsoever; and the fact that the Government may have formulated, furnished, or in any way supplied the said drawings, specifications, or other data is not to be regarded by implication or otherwise as in any manner licensing the holder or any other person or corporation, or conveying any rights or permission to manufacture, use or sell any patented invention that may in any way be related thereto.

420814

U. S. A R M Y

TRANSPORTATION RESEARCH COMMAND

FORT EUSTIS, VIRGINIA

CATALOGED BY DDC

AS AD No.

TRECOM Technical Report 63-26

FLEXIBLE WING INDIVIDUAL DROP GLIDER

FINAL REPORT

Task 1D121401A14172
(Formerly Task 9R38-01-017-72)
Contract DA 44-177-TC-827

July 1963

OCT 24 1963

TISIA A

prepared by:

RYAN AERONAUTICAL COMPANY
San Diego, California



DISCLAIMER NOTICE

When Government drawings, specifications, or other data are used for any purpose other than in connection with a definitely related Government procurement operation, the United States Government thereby incurs no responsibility nor any obligation whatsoever; and the fact that the Government may have formulated, furnished, or in any way supplied the said drawings, specifications, or other data is not to be regarded by implication or otherwise as in any manner licensing the holder or any other person or corporation, or conveying any rights or permission, to manufacture, use, or sell any patented invention that may in any way be related thereto.

* * *

DDC AVAILABILITY NOTICE

Qualified requesters may obtain copies of this report from

Defense Documentation Center
Arlington Hall Station
Arlington 12, Virginia

* * *

This report has been released to the Office of Technical Services, U. S. Department of Commerce, Washington 25, D. C. , for sale to the general public.

* * *

The findings and recommendations contained in this report are those of the contractor and do not necessarily reflect the views of the U. S. Army Mobility Command, the U. S. Army Materiel Command, or the Department of the Army.

14 October 1963

ERRATA

TRECOM Technical Report 63-26
"Flexible Wing Individual Drop Glider"

Page 31, third equation:

Now reads: $K = 1.4$ for a flat circular plate

Should read: $k = 1.4$ for a flat circular plate

HEADQUARTERS
U S ARMY TRANSPORTATION RESEARCH COMMAND
Fort Eustis, Virginia

This report was prepared by Ryan Aeronautical Company in fulfillment of Contract DA 44-177-TC-827, initiated by the United States Army Transportation Research Command, Fort Eustis, Virginia.

The conclusions made by the contractor are concurred in by this command. Based on these conclusions, recommendations are being made that further research be conducted, with the specific objectives of improving system reliability as well as aerodynamic and control efficiency of the Individual Drop Glider.

This command gratefully acknowledges the able assistance and counsel provided by the Quartermaster Research and Engineering Command, Natick, Massachusetts; Quartermaster Airborne Test Activity, Yuma Test Station, Yuma, Arizona; and the National Aeronautics and Space Administration, Langley Field, Virginia, during the course of this project.

FOR THE COMMANDER:

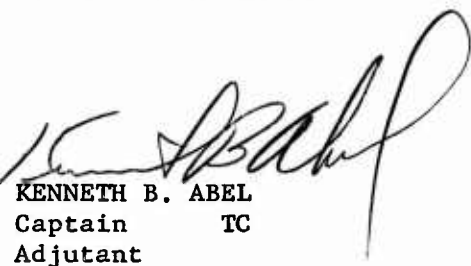

KENNETH B. ABEL
Captain TC
Adjutant

APPROVED:

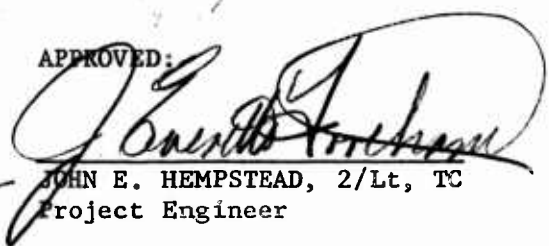

JOHN E. HEMPSTEAD, 2/Lt, TC
Project Engineer

Task 1D121401A14172
(Formerly Task 9R38-01-017-72)
Contract DA 44-177-TC-827
TRECOM Technical Report 63-26
21 July 1963

FLEXIBLE WING INDIVIDUAL DROP GLIDER

FINAL REPORT

Prepared By
Ryan Aeronautical Company
San Diego, California

FOR
U. S. ARMY TRANSPORTATION RESEARCH COMMAND
FORT EUSTIS, VIRGINIA

PREFACE

The design, fabrication, and test program covered by this report was conducted by the Ryan Aeronautical Company under provisions of Contract DA 44-177-TC-827, awarded to the Ryan Aeronautical Company by the U. S. Army Transportation Research Command.

Design, analysis, and fabrication were accomplished at the contractor's plant, San Diego, California.

All testing was conducted at the Yuma Test Station, Yuma, Arizona, between July 25 and November 21, 1962. The Airborne Test Activity at Yuma Test Station provided aircraft support, range and theodolite facilities, and hangar work space.

This Report, entitled "FLEXIBLE WING INDIVIDUAL DROP GLIDER, MODEL 149 FINAL REPORT," was authored and prepared by B. E. Kurz, Project Engineer, and approved by M. M. McDaniel, Program Manager.

The Technical Editor was W. E. Small and the Art Editor was J. Iribe of the Graphic Arts department.

CONTENTS

	<u>Page</u>
PREFACE	iii
LIST OF ILLUSTRATIONS	vii
LIST OF TABLES	xi
LIST OF SYMBOLS	xiii
SUMMARY	1
CONCLUSIONS	3
Aerodynamics and Performance	3
Structural Criteria and Loads	3
Design	4
Structures	4
Flight Test	5
RECOMMENDATIONS	7
INTRODUCTION	13
DISCUSSION	15
Aerodynamics and Performance	15
Structural Criteria and Loads	15
Design	40
Wing	40
Suspension System	50
Dummy	50
Control System	52
Instrumentation System	52
Stress Analysis	56
Weights	77
Fabrication	87
Flight Test	93
Wing Packing Procedure	93
Test Procedures	101
Test Results	107
Evaluation	111

CONTENTS

	<u>Page</u>
APPENDIX. Instrumented Flights on Which Useful Data Were Obtained	143
DISTRIBUTION	158

ILLUSTRATIONS

<u>Figure</u>		<u>Page</u>
1	Individual Drop Glider System Complete	xvii
2	Individual Drop Glider in Controlled Flight	xix
<u>Aerodynamics and Performance</u>		
3	Theoretical Wing Aerodynamic Characteristics	16
4	Theoretical Aerodynamic Characteristics of the Complete System	17
5	Theoretical Longitudinal Center of Gravity Position Required for Trim	18
6	Theoretical Longitudinal C. P. Position and an Angle of Resultant Force	19
7	Predicted Rear Riser Line Shortening Versus Incremental Change in Angle of Attack	20
8	Predicted Glide Performance	21
9	Predicted Glide Range	22
10	Theoretical Turn Radius Versus Bank Angle	23
11	Theoretical Altitude Lost in 180° Turn Versus Bank Angle	24
12	Predicted Effect of Head Winds on Landing Velocities	25
13	Predicted Velocities During Landing Flare	27
<u>Structural Criteria and Loads</u>		
14	Theoretical Keel and Leading Edge Membrane Load Distribution = 90°	41
15	Theoretical Wing Airload Characteristics	42
16	Theoretical Wing Airload Distribution	43
17	Theoretical Keel and Leading Edge Membrane Load Distribution	44

ILLUSTRATIONS

<u>Design</u>	Page
18 General Arrangement Drawing	47
19 Suspension Line Nomenclature and Location	49
20 Instrumented Dummy, Instrumentation and Control System	51
21 Ground Station Remote Control Box	53
22 Roll Control Servo Motors	54
23 Strain Gage Circuit Diagram	55
24 Accelerometer Circuit Diagram	57
25 Circuit Diagram Signal Conditioner Box	58
 <u>Fabrication</u>	
26 Upper Chest Cavity of Dummy	88
27 Lower Torso of Dummy	89
28 Installation of Upper to Lower Cavities	90
29 Complete Hardware Fabricated Dummy	91
30 Template Fabric Marking	92
31 Leading Edge, Keel, Apex Section (Close-up)	94
32 Leading Edge, Keel, Apex Section (Over-all)	95
33 Membrane Assembly Complete	96
34 Wing Assembly Complete	97
 <u>Flight Test</u>	
35 Pleating Operation - Initial	98
36 Pleating Operation	98
37 Pleated Wing	99
38 Wing - Pleated and Folded	100
39 Wing with Riser Strap Assembly Attached	102

ILLUSTRATIONS

Figure	Page
<u>Flight Test (continued)</u>	
40 Wing Stowed in Nylon Sleeve	102
41 Wing Prior to Stowage in Back Pack Container	103
42 Wing Folded in Back Pack Container	103
43 Final Wing Pack	104
44 Operational Sequence Drawing	105
45 Definition of Terms and Analysis Method for Oscillograph Record Interpretation	112
46 Opening Shock Loads - Load Factors	113
47 Opening Shock Loads - Individual Risers	114
48 Composite of Riser Opening Shock Loads	116
49 Time History - Flight No. 72	117
50 Time History - Flight No. 88	118
51 Time History - Flight No. 91	119
52 Flight Path - Longitudinal vs. Lateral Displacement - Flight No. 91	121
53 Comparison of Flight Test and Predicted Glide Performance	124
54 Paraglider Landing Velocities	124

TABLES

Table		Page
1	Configuration Changes Prior to Each Flight Test Operation	127
2	Drop Test Chronology	133
3	Evolution of Paraglider Line Lengths	137
4	Opening Shock Loads Data (Accelerometer)	138
5	Landing Shock Loads Data (Accelerometer)	138
6	Opening Shock Loads Data (Strain Gage)	139
7	Average of Opening Shock Loads (Accelerometer)	140
8	Average of Landing Shock Loads (Accelerometer)	140
9	Average of Riser Opening Shock Loads (Strain Gages)	141

SYMBOLS

A	area, ft ²
b	flatplan wing span
C _D	drag coefficient, $\frac{D}{qS}$
C _L	lift coefficient, $\frac{L}{qS}$
C _l	rolling moment coefficient, $\frac{L'_r}{qSb \text{ F. P.}}$
C _m	pitching moment coefficient, $\frac{M}{qSC}$
C _n	yawing moment coefficient, $\frac{N}{qSb}$
c. g.	center of gravity
c. p.	center of pressure
C	section chord, ft
c	keel length, ft
c	distance to outer fiber, ft
D	drag force parallel to flight path C _D qS, lb
D	diameter, ft
F	force, lb
F _{tu}	ultimate tensile stress, lb/in ²
f _b	bending stress, lb/in ²
f _t	tension stress, lb/in ²
h	altitude, feet

SYMBOLS

I	moment of inertia, inches ⁴
k	opening shock factor
L' _R	rolling moment
l	length of member or line, ft
l	distance, ft
m	mass, slugs
M	bending moment
M	pitching moment, Cm _q SC
N	hoop load per foot of width, lb/ft ²
N	normal force, lb
N _o	required strength per unit length, lb/in
N	yawing moment
n	load factor
P	load, lb
p	wing load $\frac{n_z W}{S}$ lb/ft ²
p	pressure, lb/ft ²
q	dynamic pressure, $\frac{\rho}{2} V^2$, lb/ft ²
R	gas constant, ft - lb/lb - °R
R	radius of wing membrane, ft
R	radius of inflatable tubes, ft
S	flatplan wing area or reference area, ft ²
t	time
t	thickness, inches

SYMBOLS

V	free stream velocity, ft/sec or knots
V	volume, ft ³
W, WT	weight, lb
x	longitudinal distance, ft
Y	lateral distance, ft
y	distributed load, lb/ft
a, α	angle of attack, degrees
γ	flight path angle from horizon, degrees
ϵ	angle between the wing resultant force and a normal to the plane of the leading edge members
θ	wing pitch attitude, degrees
Λ	leading edge sweep angle degrees
ρ	mass density of air, slugs/ft ³
σ_L	longitudinal membrane stress



Figure 1 Individual Drop Glider System Complete



Figure 2 Individual Drop Glider in Controlled Flight

SUMMARY

The objective of this program was to establish the feasibility of the paraglider concept as a means of descent for individual airborne troops. Full-scale 22-foot inflatable wings and instrumented dummies were designed, fabricated, and flight tested to demonstrate this feasibility.

Specific areas of investigation included packing methods, deployment, transition from the parachute mode into the wing, controllability, glider performance, and the human tolerance aspect in relation to opening shock, landing loads, and velocities.

Considerable testing was directed toward determining the best packing method and deployment technique in an effort to achieve system reliability.

The feasibility of using the paraglider as a means of controlled delivery of airborne paratroopers was successfully demonstrated.

Items of importance were the verification of offset launch capability, predetermined landing site selection, and controlled maneuverability during descent, all of which can be achieved within the human tolerance envelope.

CONCLUSIONS

As a result of the flight tests conducted on the Ryan application of the Rogallo wing principle to the concept of an individual man drop paraglider, the following conclusions are drawn.

AERODYNAMICS AND PERFORMANCE

1. The theoretical wing size selection in relation to glide slope and velocities was verified by data accumulated throughout the flight test portion of the program.
2. Landing velocities, both horizontal and vertical, were as predicted and comparable to the human tolerance envelope.
3. System control, utilizing c. g. shift, was demonstrated during the flight test portion of the program.

STRUCTURAL CRITERIA AND LOADS

The theoretical loads analysis conducted during the design phase of the Individual Drop Glider Program predicted loads which appeared to be reasonable when compared to similar personnel parachute systems. The analysis was based on the method of analysis presented in the U. S. A. F. Parachute Handbook (WADC-TR-55-265). The one area of discrepancy was the predicted loads for opening shock force. The results of the analysis showed the opening shock force load factor to be 8.55g. This load factor was substantiated by the recorded data of the instrumented flight test system. Accelerometer readings gave an average reading of 5.75g, and the strain gage data yielded an average reading of 7.1g. However, a closer examination of the comparison of the data reveals that the theoretical analysis is based on a drop velocity of 130 knots, whereas the flight test data are based on a velocity of 65 knots. The velocity ratio of 2:1 results in a 4:1 ratio of dynamic pressure. Although the theoretical load is not exactly linear with respect to the dynamic pressure, it is indicative of the difference in order of magnitude. Therefore, the corresponding theoretical load for the flight test conditions would be approximately 2.1g. This illustrates clearly that the analysis yields loads which are only one-third of flight test data. Therefore, a

more accurate method of loads analysis for opening shock force must be derived for use in the design of inflatable wings.

DESIGN

1. The initial wing design with modifications and the final material selection provided an adequate system for concept feasibility evaluation.
2. Inflatable structure should not be utilized for load distribution purposes during snatch and opening shock phases of the deployment cycle.
3. The parachute phase is the most critical for system loading; the transition phase is the most critical for over-all system reliability.
4. Load distribution through gusset to membrane attachments provides a more uniform stress distribution into the basic fibers of the material.
5. Simultaneous release of the forward and aft shroud lines from the parachute mode into the glider mode is required.

STRUCTURES

The stress analysis conducted on the Individual Drop Glider System was based on the theoretical loads calculated during the design phase. The maximum load criteria was based on a load factor of 8.55g. This design factor is greater than the actual factor as recorded in flight tests. Therefore, the design should have been adequate for the flight test conditions. However, it became apparent during the initial flight test stages that the wing structure was inadequate. Structural failures at various locations on the wing during deployment seemed to indicate that the stress analysis was not correct. However, laboratory tests of the design prior to and after initial flight tests bore out the integrity of the structure for static applications of the predicted loads. A closer examination of the problem pointed to dynamic impact loads and their distributions as being the logical reason for the failures. Structural modifications to the problem areas increased the reliability of the design to an acceptable level. However, this did not eliminate the original problem. The modifications included, among other things,

increased strength and a change to better materials. These modifications gave impetus to the theory that static strength was not the lone criteria for design. It is firmly established that dynamic loads in elastic members reach fantastic heights over extremely short periods of time. For the majority of metallic structures, these dynamic loads do not present a problem. However, fabrics offer very little resistance to failure from notch effect. Bonded joints which are extremely efficient in shear prove to be very notch sensitive due to the discontinuity in elasticity (shear lag effect) at the joints. The loads experienced by the wing canopy during deployment do not necessarily reveal their true intensities in the payload or riser lines. The loads experienced by the canopy could very easily be absorbed or dissipated in the elongation of the canopy and/or shroud lines. The prediction of this effect cannot accurately be accomplished with data available at this time. Future stress analysis must definitely include the effects of dynamic impact stresses.

FLIGHT TEST

1. The feasibility of using an inflatable flexible wing as a controllable paraglider for an individual man drop has been demonstrated.
2. The opening shock loads and accelerations during paraglider deployment are within human tolerances.
3. Equilibrium rates of descent of the paraglider are as predicted.
4. Control of the glider in most cases was marginal due to angle of attack investigations during descent. This cut down the amount of riser length available for control inputs and effective c.g. shift. On the final flight of the program, differential control inputs yielded excellent control and maneuverability. It is therefore anticipated that under actual man drop conditions, authoritative control could be exercised by a paratrooper.
5. Landing impact loads were within allowable human tolerances.
6. Landing velocities, vertical and horizontal, are compatible with the allowable values for conventional personnel parachutes.

RECOMMENDATIONS

As a result of the satisfactory concept feasibility demonstration of the Individual Man Drop Glider, it is recommended that the following be incorporated in the next phase of the development of a flexible wing paraglider.

I Material Research and Testing

A. Evaluate new materials and adhesives (inflatable members)

1. Material optimization

- a. Minimum base cloth weight
- b. Minimum coating
- c. Fabric flexibility
- d. High strength
- e. Tear and notch resistant
- f. Abrasion resistant
- g. Crease resistant
- h. High energy absorption
- i. Nonporous
- j. Shelf life

2. Adhesive optimization

- a. Unlimited shelf life
- b. Single adhesive
- c. Material/coating compatibility
- d. High strength
- e. Ease of application

B. Evaluate New Materials and Adhesives (membrane)

1. Nonporous
 - a. -h. Same as section I. A. 1.
2. Porous
 - a. Minimum cloth weight
 - b. High strength
 - c. Tear and notch resistant
 - d. Abrasion resistant
 - e. Crease resistant
 - f. High energy absorption
3. Adhesive optimization
 - a. -e. Same as section I. A. 2.

II Pneumatic System Investigation

Air bottle versus gas generator

Parametric study entailing

- a. Inflatable volume
- b. Minimum inflation time
- c. System weight
- d. Recharge capability
- e. Shelf life
- f. Reliability
- g. Compatibility of gas with fabric and adhesive

III Prototype Design [(2) keel lengths (1) greater than 22'.
(1) less than 22' to evaluate scale effect]
Configuration evaluation

1. Inflatable (tubes)
 - a. Diameter
 - b. Wall thickness
 - c. Camber
 - (1) leading edge
 - (2) keel
 - d. Aerodynamic fairing
 - e. Method of attaching to membrane
2. Membrane
 - a. Scalloped trailing edge
 - b. Shaped
 - c. Nonporous
 - d. Porous
3. Line attachments (load distribution) (number and location)
 - a. Leading edge
 - b. Keel
4. Redundancy within the tube member (2) section.

IV Fabrication of Test Articles

V Instrumentation of Test Articles

VI Wind Tunnel - Tower - Aircraft Tests

A. Structure

1. Determine membrane stresses
2. Determine tube stresses

3. Porous versus nonporous membrane opening shock loads
4. Parachute and wing shroud line loads
5. Optimize pack methods to alleviate opening shock loads

B. Deployment

1. Static line/sleeve
2. Static line/deployment bag
3. Static line/sleeve/extreme forward c. g.
4. Sleeve/pilot chute

C. Transition

1. Extreme forward c. g. (ballistic path) investigation to eliminate parachute completely.
2. Shroud line stowage

D. Aerodynamics (performance)

1. Inflatable (tubes)
 - a. Diameter
 - b. Fairing
 - c. Camber
 - (1) Leading edge
 - (2) Keel
2. Membrane
 - a. Scalloped trailing edge
 - b. Shaped
 - c. Nonporous
 - d. Porous

E. Control

- 1. Center of gravity shift**
- 2. Aileron**

INTRODUCTION

With the recognition that the Rogallo Paraglider possessed the capability of being utilized in many unique environments, a number of theoretical and experimental investigations have been conducted to determine the feasibility of using this concept as a delivery system for various payloads under various environmental conditions.

One such application is the use of the paraglider as a means of descent for airborne troops. Such an application requires a wing with inflatable structural members, enabling the wing to be folded and packed. Consequently, in addition to satisfactory performance and flying characteristics, operational feasibility is dependent on a reliable packing and deployment sequence.

The name Flexible Wing Individual Drop Glider (IDG) aptly describes the vehicle required for that type of application and therefore is the name selected to describe this program.

Prior to this program, a 10-foot scale model of an inflatable wing had been built and tested by the Ryan Aeronautical Company. The results of those tests showed that an inflatable wing does have favorable flying qualities and can be packed and successfully deployed.

The present tests were undertaken to establish system feasibility, using a full-scale wing and payload. Primary areas of interest during the test program were packing and deployment, performance, and human factor aspects such as opening shock loads and landing velocities.

DISCUSSION

AERODYNAMICS AND PERFORMANCE

This section contains aerodynamic characteristics and performance data supplemental to Ryan Report No. 62B013 (Reference 1). In addition to these data, portions of the aerodynamic data from the above-mentioned report have been included as a basis for comparison and to make this section usable without continuous reference to Report 62B013.

The performance data presented previously were based on having the payload suspended 75 per cent of the keel length below the wing, and the glider proposed in Reference 1 is designed with this vertical attach distance. It was felt, however, that a payload suspension distance greater than 75 per cent merited investigation; therefore, longitudinal characteristics of the glider with the payload suspended one full keel length below the wing were calculated and are presented in this section.

The longitudinal c. g. positions required to trim the glider with vertical attach distances of .75 and 1.0 keel lengths were calculated from an equation representing a moment summation about the c. g. These curves were utilized to develop the general arrangement and rigging drawing (Ryan Drawing No. 149-B-001).

Turn performance as a function of bank angle is presented. These estimates are based on coordinated turns and are therefore only approximate. Glide performance for standard- and hot-day conditions is based on glide at an angle of attack of 30° except for rates of descent, which were calculated as a function of angle of attack.

STRUCTURAL CRITERIA AND LOADS

The structural design of the paraglider is based upon the loads developed during all phases of the system operation. In addition to the loading requirements, consideration must be given to the problems of packaging, environment, and deployment. The design constraints on the wing construction are determined from the operating environment and human force and acceleration limitations. These constraints are:

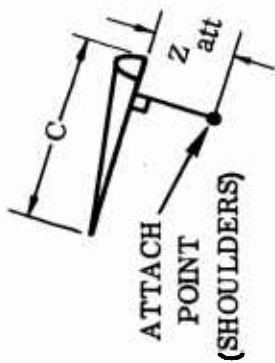

- NOTE: 1. C_L , C_D , & L/D ARE FOR WING ONLY
 2. C_L AND C_D ARE BASED ON FLATPLAN WING AREA (277.6 FT^2)
 3. ——— $Z_{att}/C = .75$
 - - - $Z_{att}/C = 1.0$

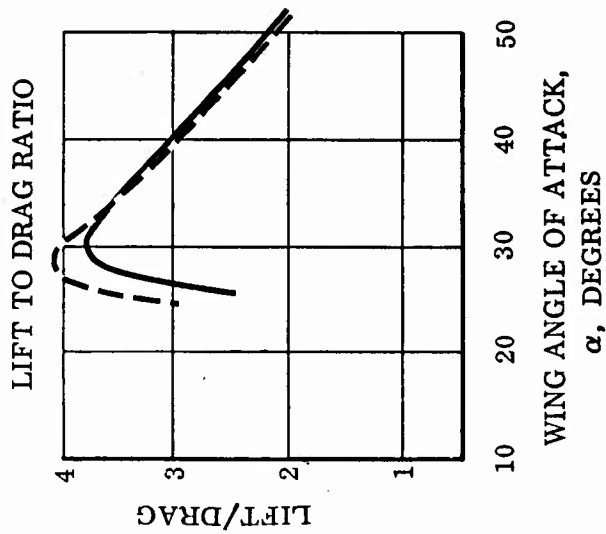
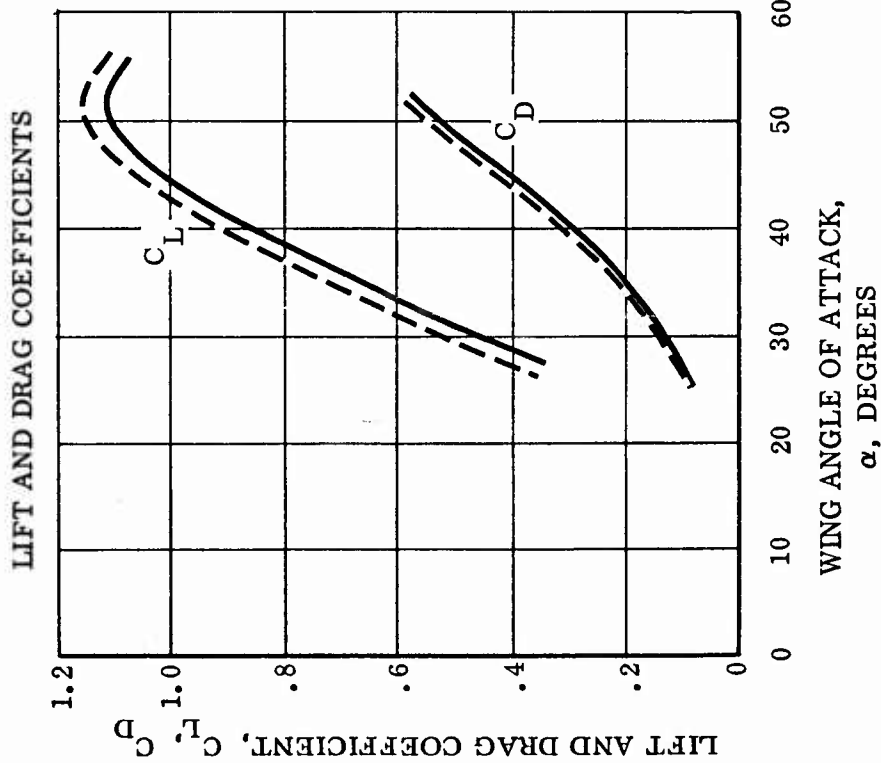
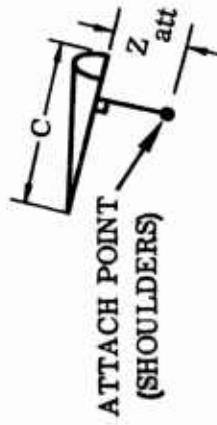
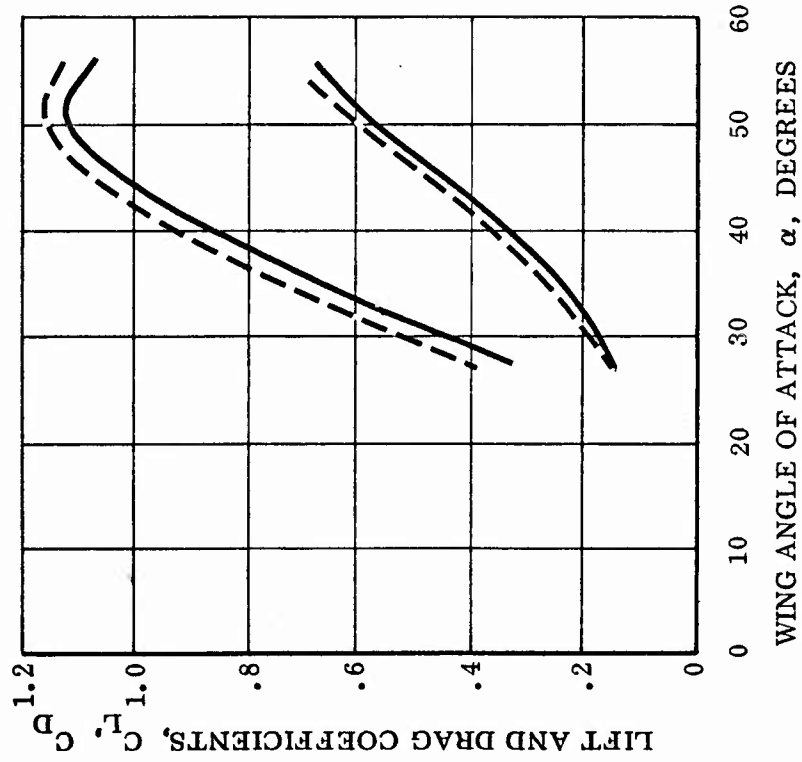

Figure 3 Theoretical Wing Aerodynamic Characteristics



NOTE: 1. ——— $Z_{att}/C = .75$
 2. - - - $Z_{att}/C = 1.0$

LIFT AND DRAG COEFFICIENTS



LIFT TO DRAG RATIO

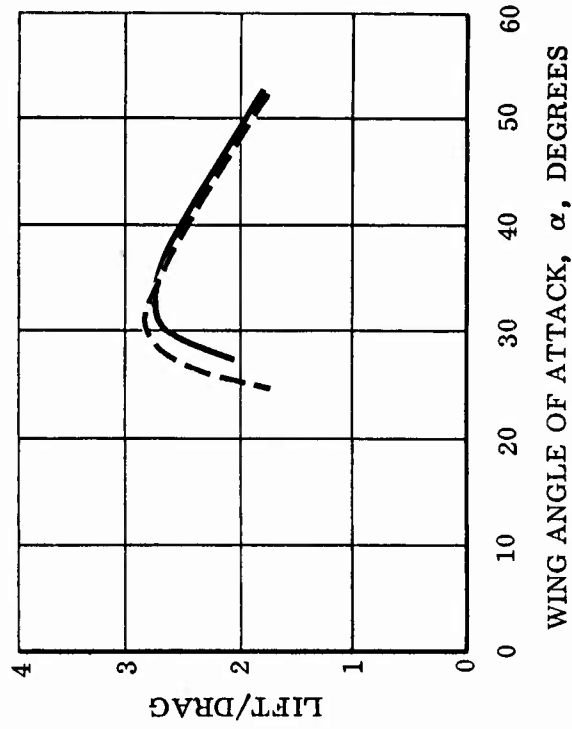

Figure 4 Theoretical Aerodynamic Characteristics of the Complete System

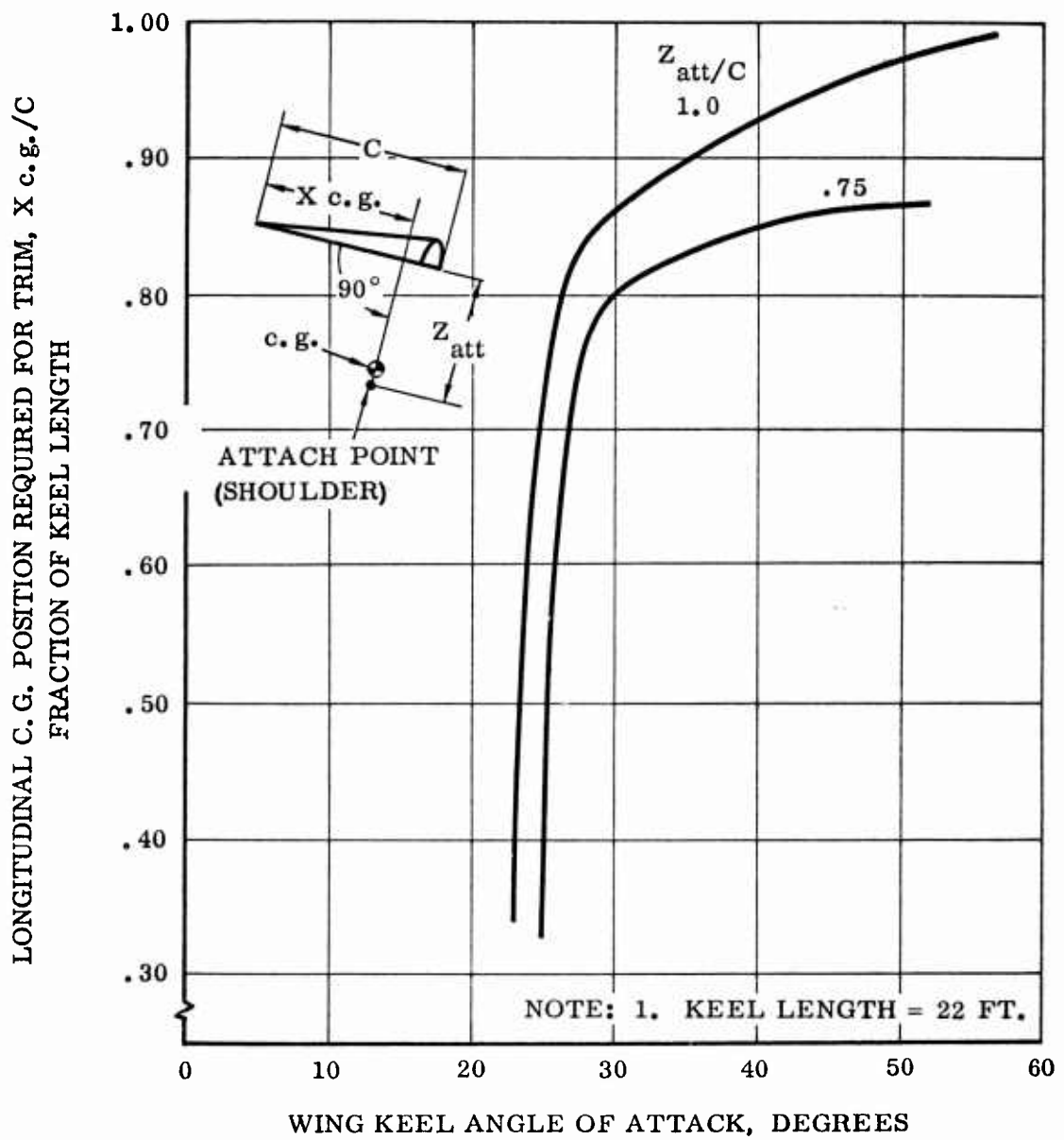

Figure 5 Theoretical Longitudinal Center of Gravity Position Required for Trim

- NOTE: 1. $Z_{att/C} = 1.0$
 2. FLATPLAN SWEEP = 55°
 3. KEEL LENGTH = 22 FT.

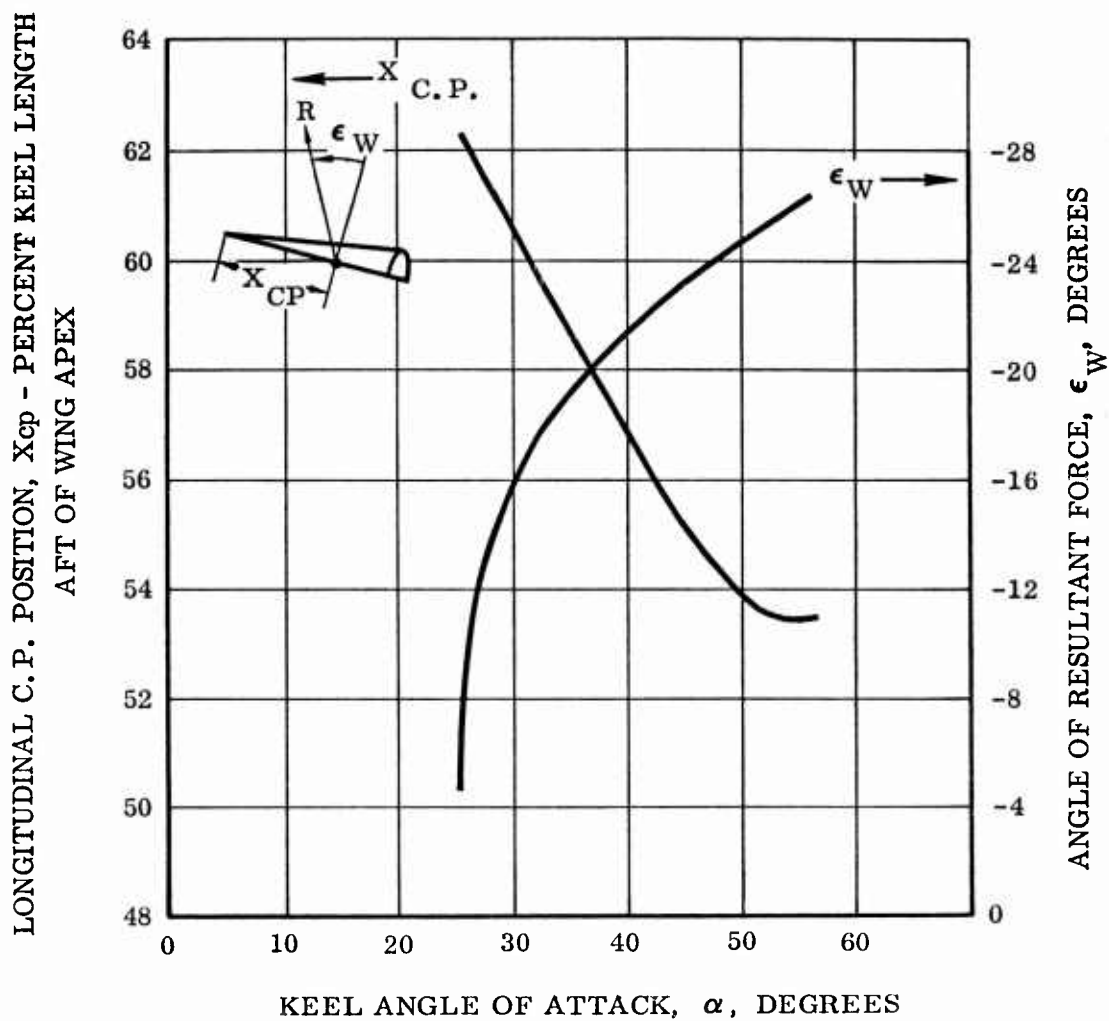

Figure 6 Theoretical Longitudinal C. P. Position and An Angle of Resultant Force

- NOTE: 1. LINE SHORTENING SHOWN INCLUDES A 30% MARGIN TO ACCOUNT FOR THE FLEXIBILITY OF THE SYSTEM.
2. WITH ZERO LINE SHORTENING, GLIDER IS TRIMMED FOR A 38° ANGLE OF ATTACK.

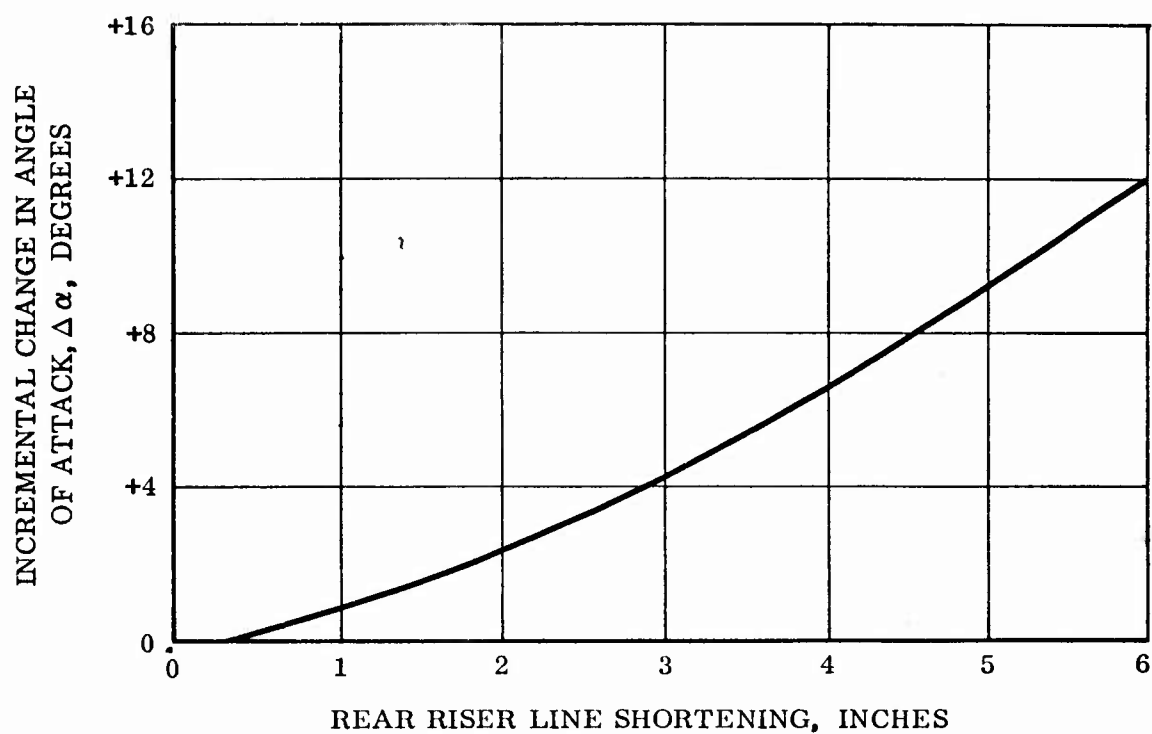
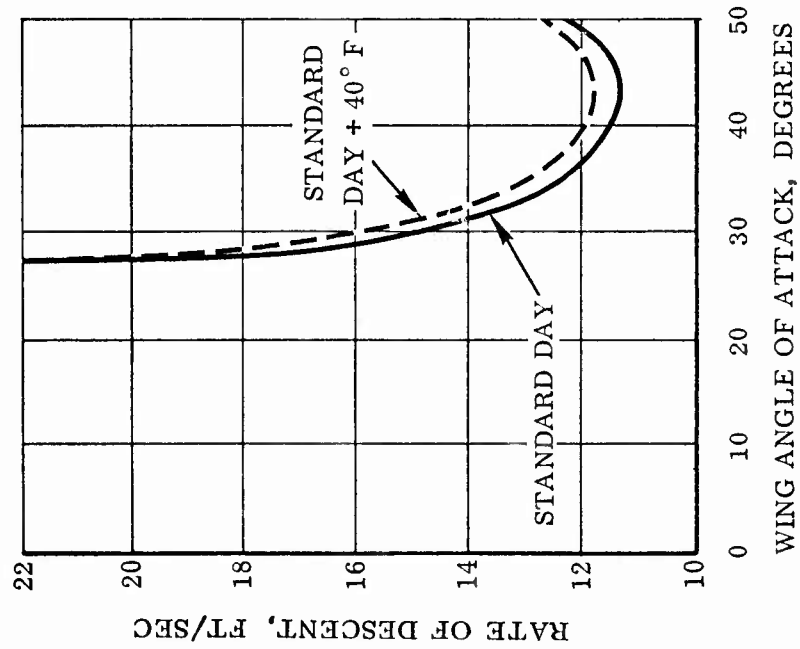

Figure 7 Predicted Rear Riser Line Shortening Versus Incremental Change in Angle of Attack

RATE OF DESCENT AT SEA LEVEL



GLIDE TIME

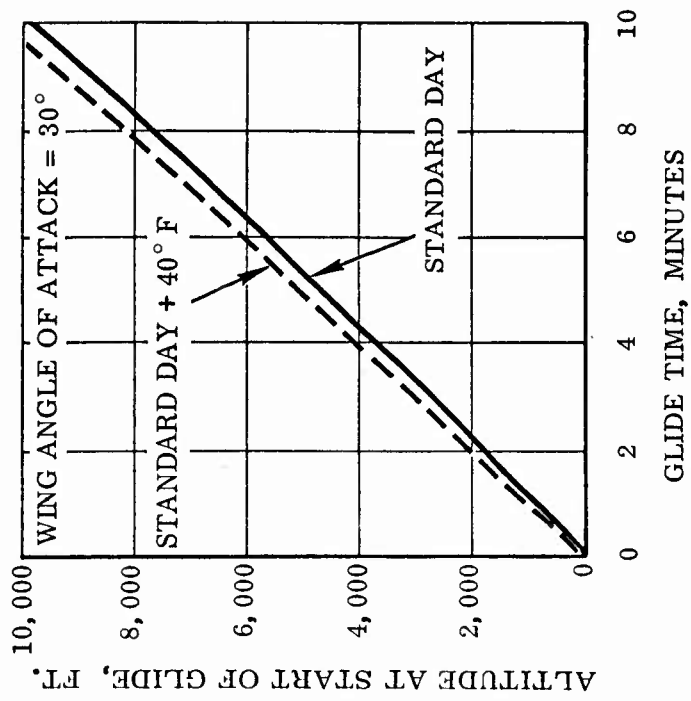

Figure 8 Predicted Glider Performance

- NOTE: 1. ANGLE OF ATTACK, α , = 30°
2. NO WIND
3. APPLICABLE TO STANDARD OR
HOT DAY CONDITIONS

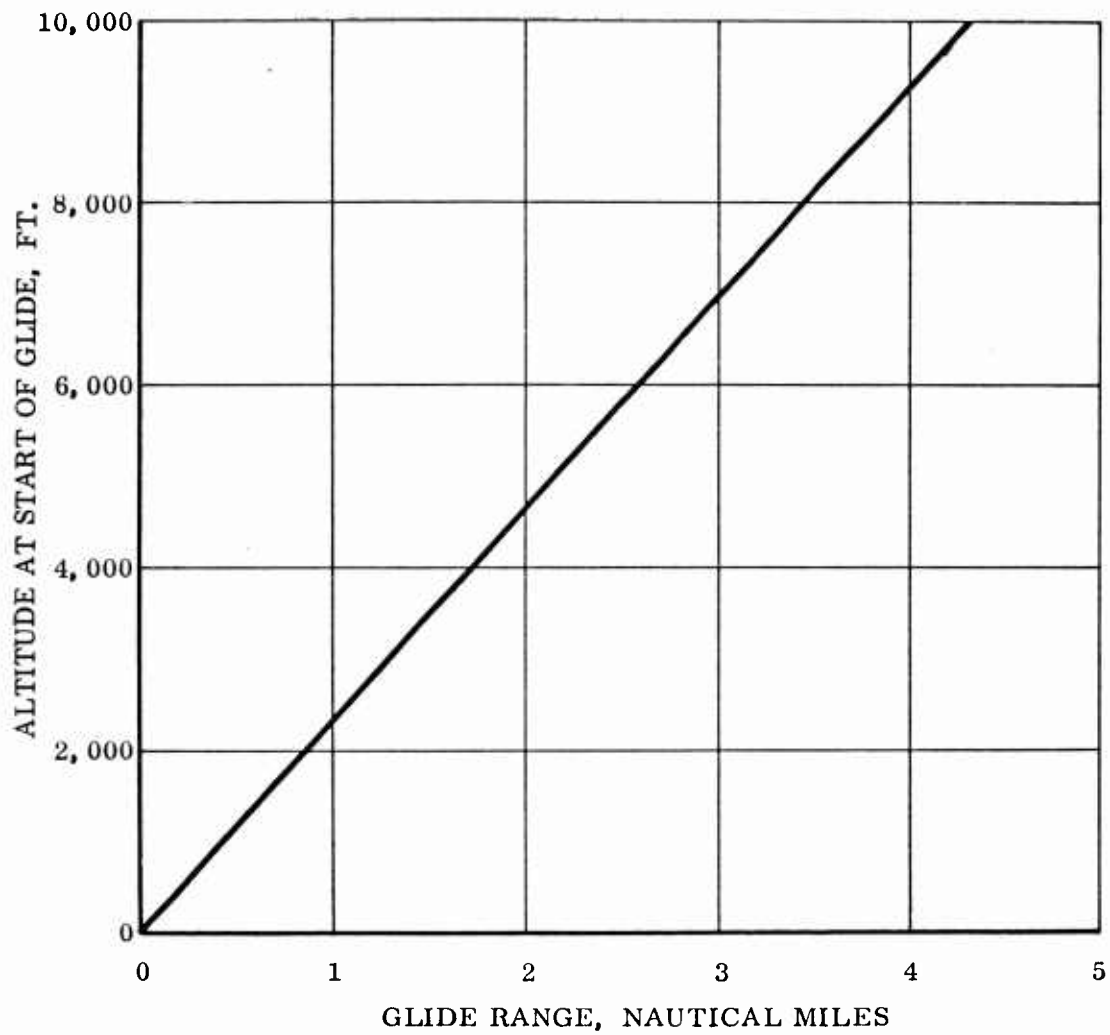

Figure 9 Predicted Glide Range

- NOTE: 1. ANGLE OF ATTACK, α , = 30°
2. STANDARD DAY
3. NO WIND

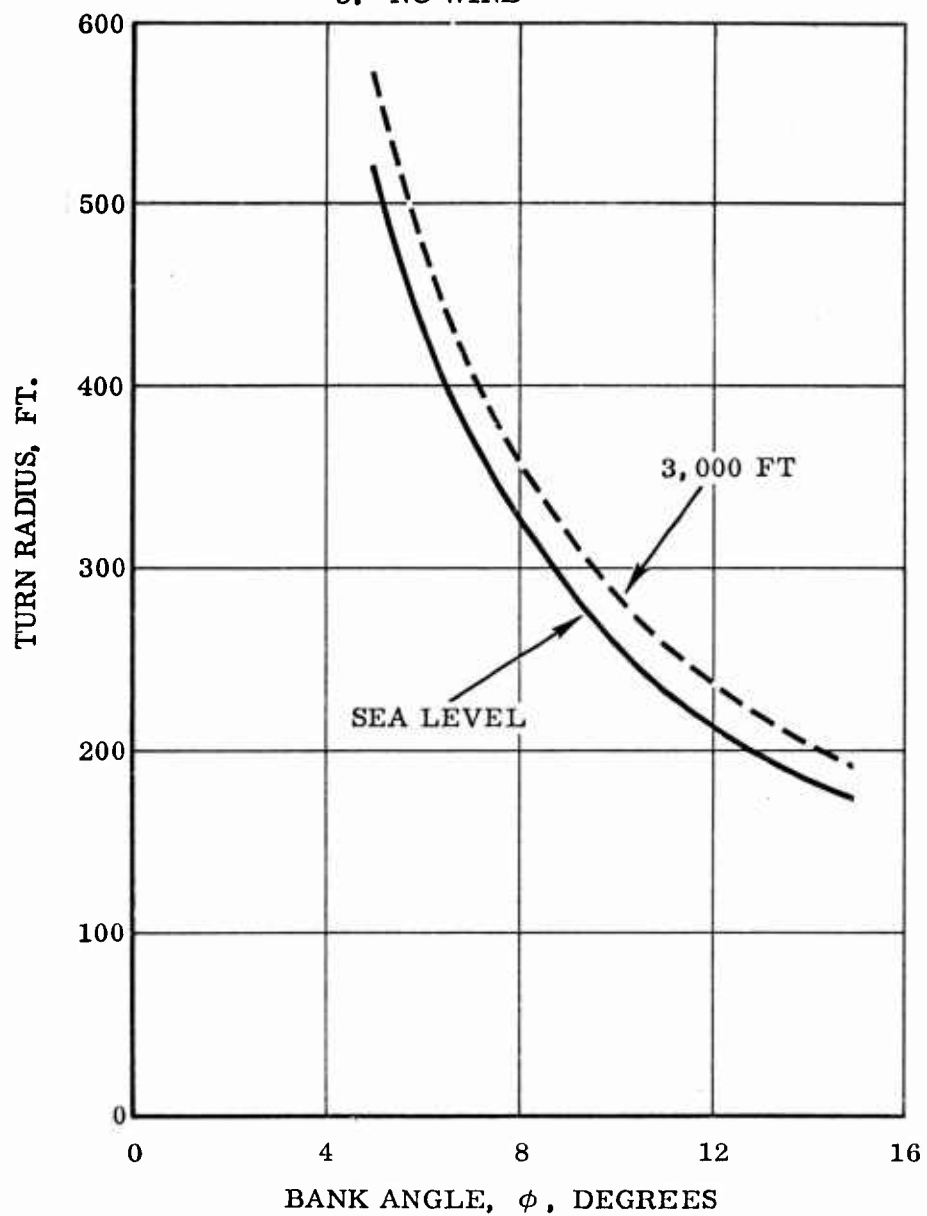

Figure 10 Theoretical Turn Radius Versus Bank Angle

- NOTE: 1. ANGLE OF ATTACK, α , = 30°
2. STANDARD DAY

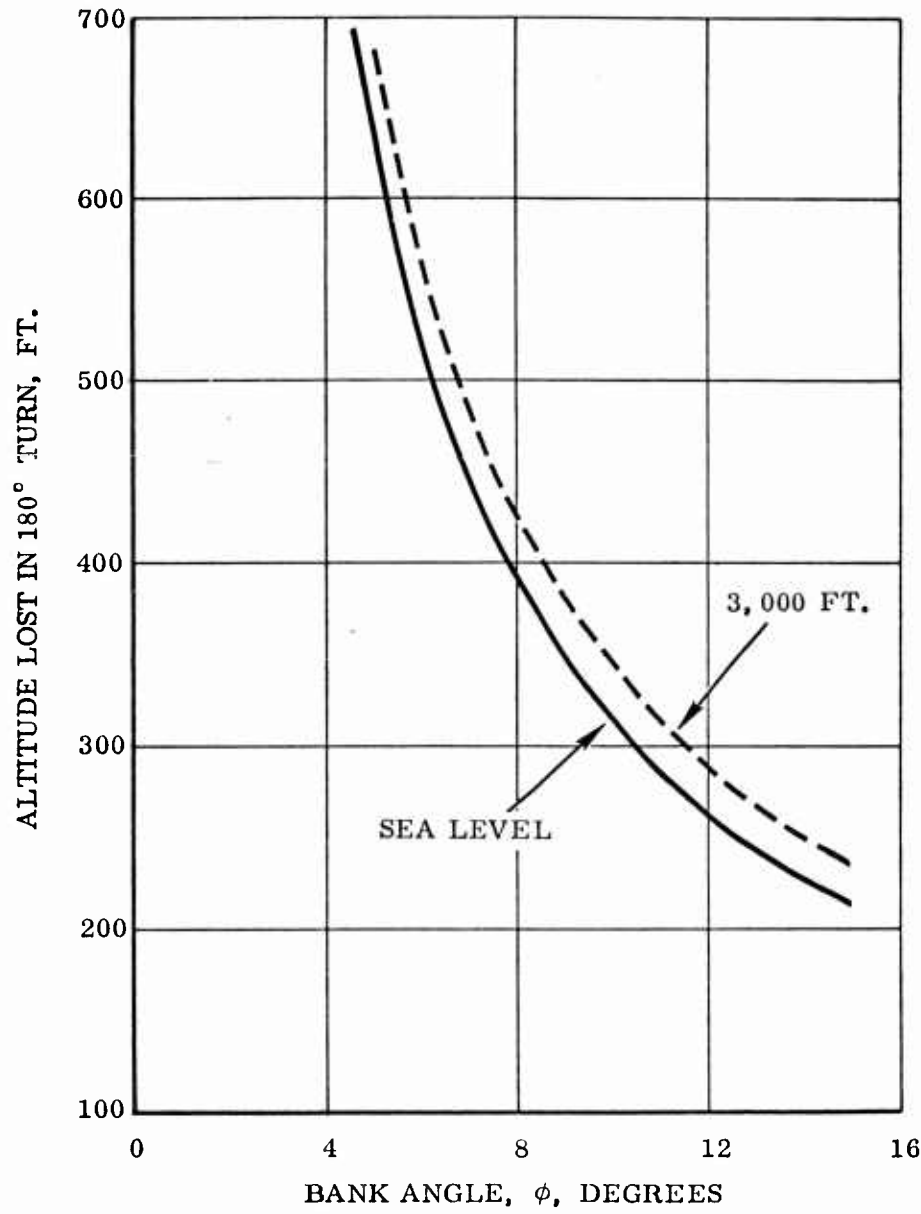
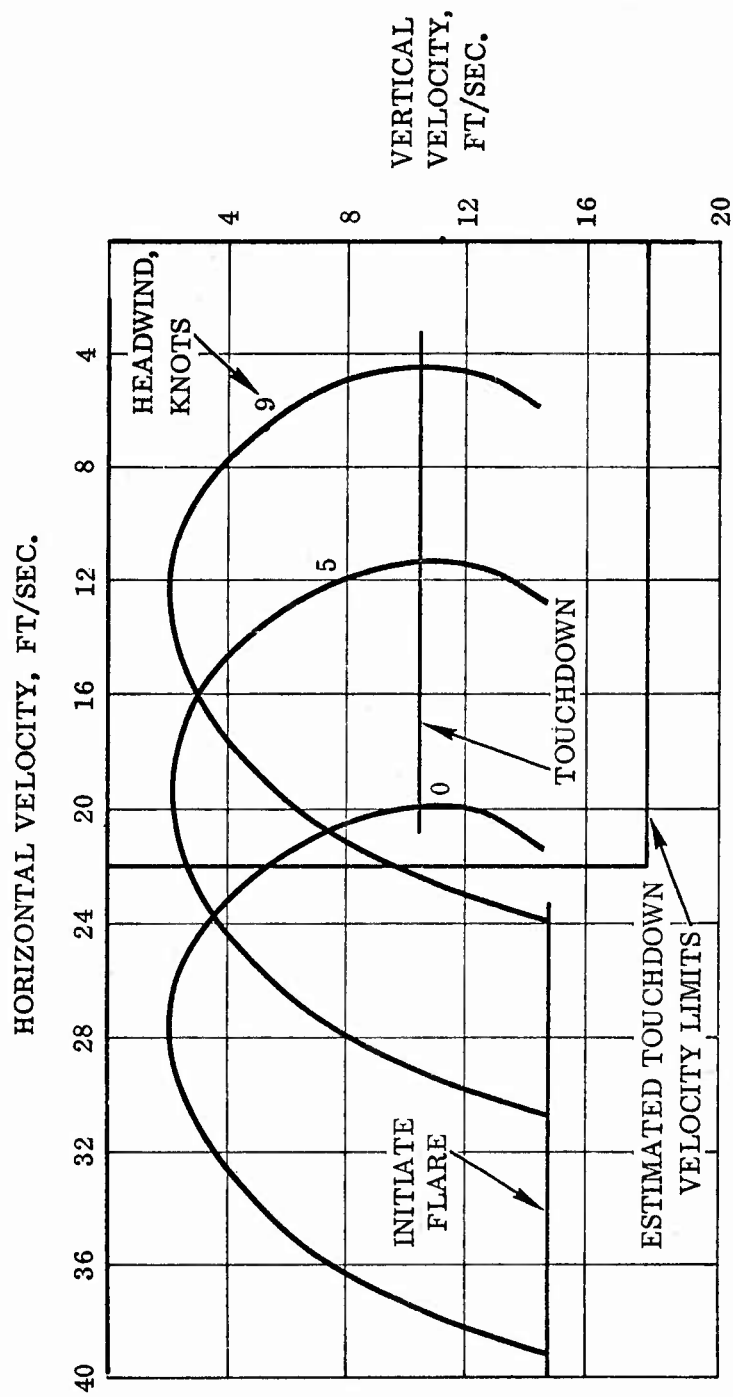

Figure 11 Theoretical Altitude Lost in 180° Turn Versus Bank Angle



- NOTE: 1. GLIDE ANGLE OF ATTACK = 30°
 2. STEP CONTROL INPUT TO TRIM 50°
 ANGLE OF ATTACK
 3. GROSS WEIGHT = 300 LB.

Figure 12 Predicted Effect of Head Winds on Landing Velocities

HORIZONTAL VELOCITY

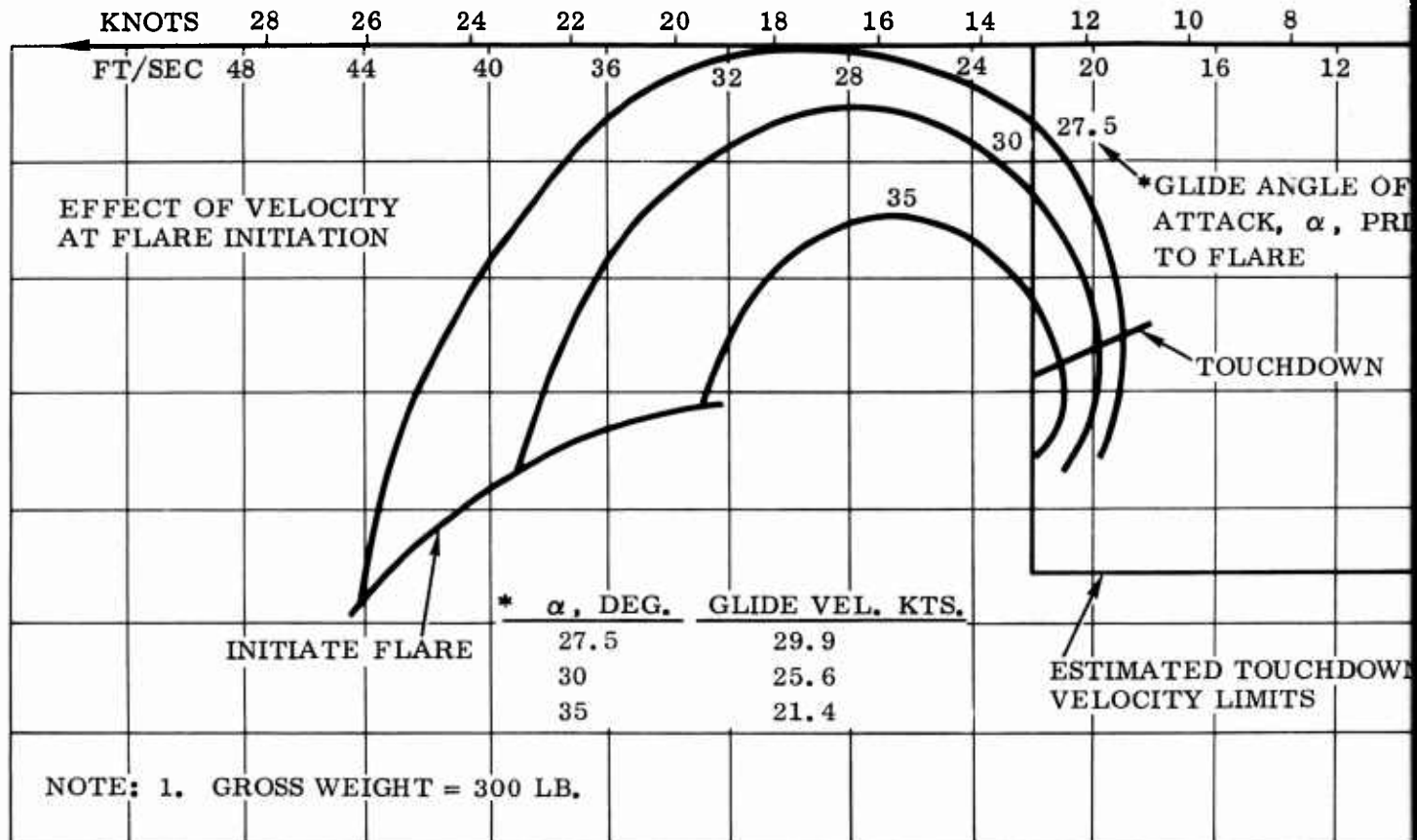

NOTE: FLARE
TO A TH

1

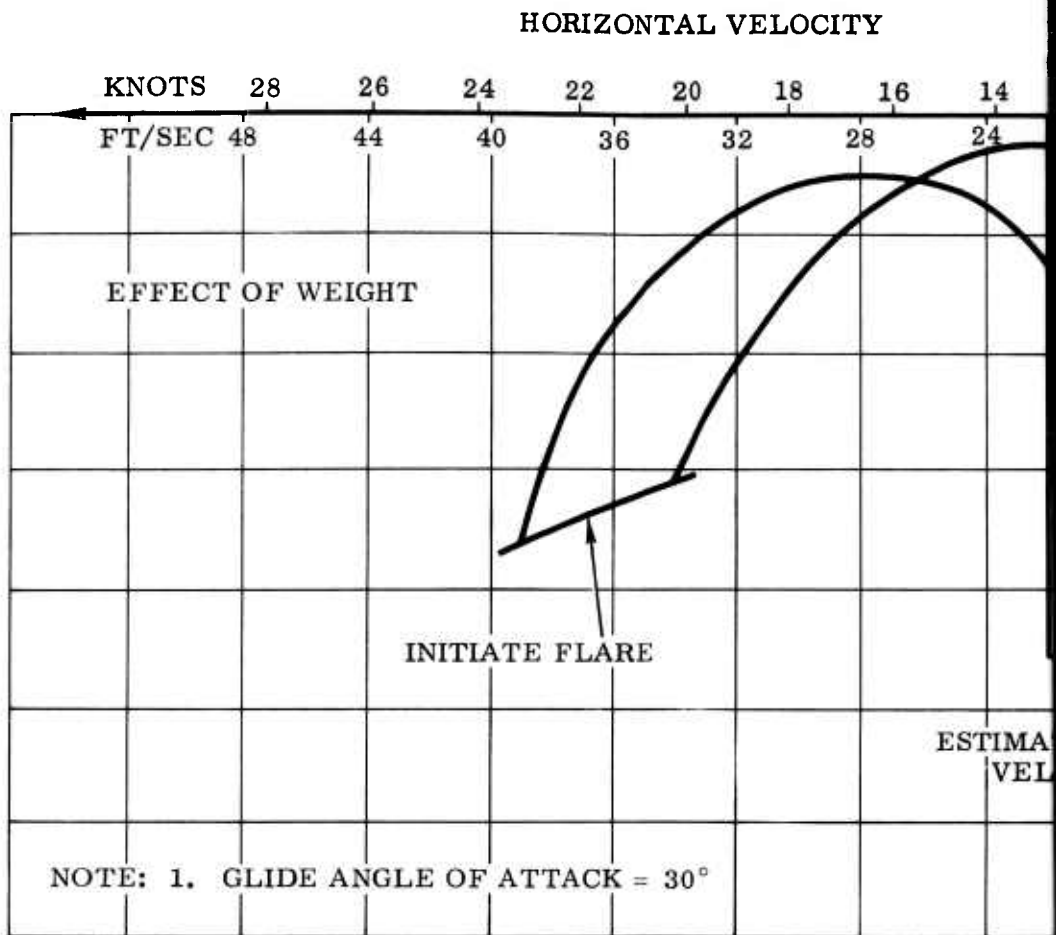
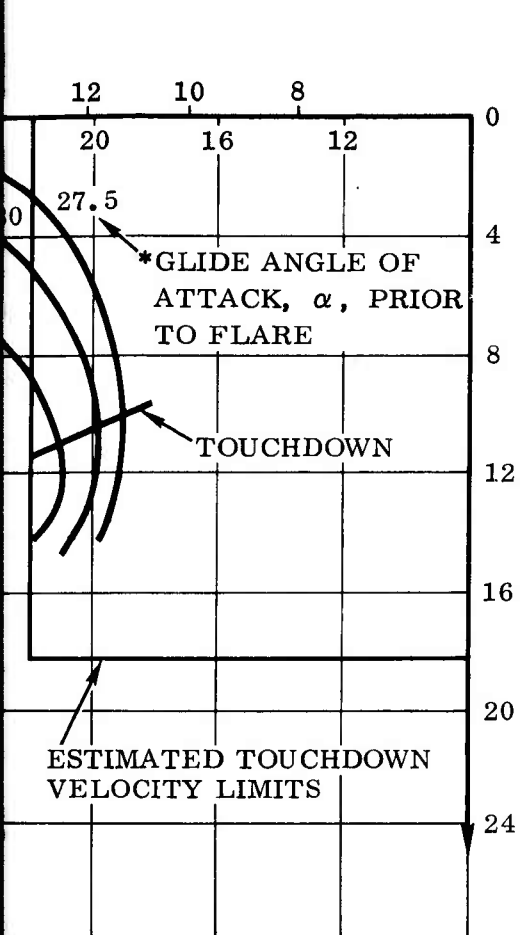

NOTE: FLARE IS INITIATED BY A STEP CONTROL INPUT TO A TRIM 50° ANGLE OF ATTACK

2

Figure 13 Predicted Vel

HORIZONTAL VELOCITY

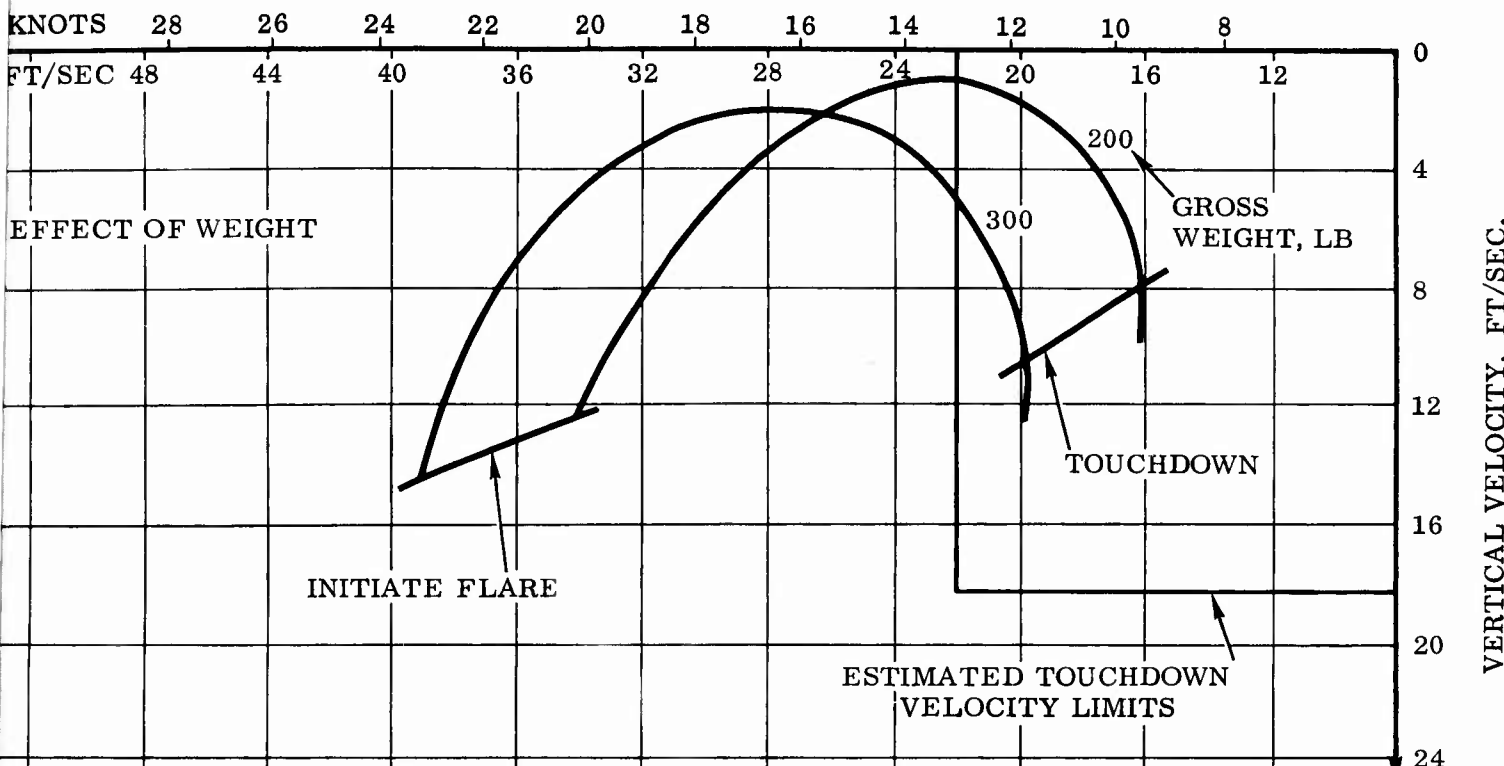

EFFECT OF WEIGHT

GROSS WEIGHT, LB

TOUCHDOWN

INITIATE FLARE

ESTIMATED TOUCHDOWN VELOCITY LIMITS

NOTE: 1. GLIDE ANGLE OF ATTACK = 30°

P CONTROL INPUT
ACK

3

Figure 13 Predicted Velocities During Landing Flare

1. Material used in the wing must be flexible and lightweight. It must retain essential properties during environmental conditions that can be expected during field operations. It must be capable of being stored in the folded configuration for extended periods of time.
2. Packaging of the paraglider must consider the capabilities of the fully loaded airborne troop. A package size approaching that of the present T-10 parachute is desirable.
3. The weight of the system shall be kept to a minimum.
4. The construction shall allow for folding consistent with sound deployment procedures.
5. Accelerations encountered during deployment shall be within acceptable human tolerances.
6. A factor of safety of 2 will be observed for all conditions and for all components.

The critical load factor experienced by the paraglider system occurs during the deployment sequence. The system shall be designed for the following conditions during deployment:

Design Weight	300 pounds
Individual Weight	265 pounds
Design Limit Load Factor (N_0)	8.55

The design limit load factor occurs during opening shock of the wing while reefed as a parachute. The theoretical procedures employed in the analysis are patterned after the methods outlined in WADC-TR-55-265.

Since the proposed configuration consists of the wing deployed initially reefed to a state resembling a parachute, deployment shall be made by use of a deployment sleeve and a static line or small extraction chute.

In the analytical treatment of the opening dynamics, the reefed wing (effectively a parachute) was assumed to have the characteristics of a flat, circular parachute. The diameter of 15.5 feet (D_0) corresponds to the inscribed circle on the wing's flat planform. The associated drag coefficient (C_{D_0}) is 0.75.

For this analysis, the following conditions were chosen for the opening shock analysis:

Jump Velocity (V_o)	130 knots
Jump Altitude (h_o or h_s)	Sea level
Static Line Length (l_s)	15 feet
'Chute Plus Suspension Line Length (l_c)	16.5 feet

The velocity just prior to parachute filling (V_s) can be determined from the following equation:

$$V_s = \frac{V_o}{\left[1 + \frac{(C_D S)_B \rho g t_D V_o}{(2) W_t} \right]}$$

Where	$(C_D S)_B$	= Drag area of man	= 5 ft ²
	ρ	= Air density	= 0.002378 slug/ft ³
	g	= Gravitational constant	= 32.17 ft/sec ²
	W_t	= Suspended weight	= 265 pounds
	t_D	= Deployment time	= seconds

The velocity V_s is assumed equal to V_o . Therefore, the parachute filling time is determined from the equation

$$\begin{aligned}
 t_f &= 8 D_o / V_s^{0.9} \\
 &= \frac{(8) (15.5)}{(220)^{0.9}} \\
 &= 0.97 \text{ seconds}
 \end{aligned}$$

$$\begin{aligned}
 \text{Factor A} &= \frac{2 W_t}{C_{D_o} S_o V_s \rho t_f g} \\
 &= \frac{(2) (265)}{(0.75) (\pi) (7.75)^2 (220) (2.378) (10)^{-3} (0.97) (32.17)} \\
 &= 0.230
 \end{aligned}$$

From Figure 4-2-2 (WADC TR 55-265),
the decreasing factor $x = 0.225$

The opening shock force is

$$\begin{aligned}
 F_o &= C_{D_o} S_o q_s x k \\
 K &= 1.4 \text{ for a flat circular plate} \\
 F_o &= (0.75) (\pi) (7.75)^2 (0.50) (2.378) (10)^{-3} (220)^2 (0.225) (1.4) \\
 &= \underline{\underline{2564 \text{ lb limit}}} \\
 N_o &= \underline{\underline{8.55 \text{ g limit}}}
 \end{aligned}$$

The snatch force for the reefed paraglider is given by

$$P = \sqrt{\frac{W_c}{8} V^2 Z \frac{P_{\max}}{\max}}$$

$$\begin{aligned}
 \text{where} \\
 \Delta V &= V_o^2 \frac{t K_b (n-1)}{1 + V_o t K_b (n+1) + V_o^2 n K_b^2 t^2}
 \end{aligned}$$

and where

$$K_b = \frac{C_{D_b} S_b \gamma}{2 W_b}$$

Where

$$K_b = \text{drag loading of the suspended load, ft}^{-1}$$

$$C_{D_b} = \text{coefficient of drag of suspended load}$$

$$\gamma = \text{specific weight of air, lbs per cu. ft}$$

$$W_b = \text{weight of suspended load, lb}$$

$$S_b = \text{aerodynamic area of suspended load}$$

$$K_p = \frac{C_{D_o} S_o \gamma}{2 W_p} \text{ for the parachute}$$

Where

$$K_p = \text{drag loading of the uninflated parachute, ft}^{-1}$$

$$C_{D_o} S_o = \text{average drag area of the uninflated parachute plus drag area of the extraction chute.}$$

$$W_p = \text{weight of canopy cloth area plus weight of external suspension lines, lb}$$

$$n = \frac{K_p}{K_b}$$

$$d = \text{distance from the center of gravity of the canopy to the suspension point on the load.}$$

ANALYSIS

$$\text{Let } C_{D_o} S_o = 4 \text{ ft}^2$$

$$W_p = 32.5 \text{ lb}$$

$$\gamma = 0.0766 \text{ lb/ft}^3$$

$$\therefore K_p = \frac{(4)(0.0766)}{(2)(32.5)}$$

$$= 0.00471$$

$$(C_D S)_B = 5 \text{ ft}^2$$

$$W_B = 265 \text{ lb}$$

$$\gamma = 0.0766 \text{ lb/ft}^3$$

$$K_B = \frac{(5)(0.0766)}{(2)(265)}$$

$$= 0.00072$$

$$n = \frac{K_p}{K_B} = \frac{0.00471}{0.00072} = 6.542$$

$$d = 16.5 \text{ feet}$$

$$\text{For } \left. \begin{array}{l} K_p = 47.1 \times 10^{-4} \\ K_b = 7.2 \times 10^{-4} \end{array} \right\} t = 0.45 \text{ seconds}$$

(Ref: WADC-TR-55-265

Pg 4-1-7 Figure 4-1-11)

$$\text{Now } \Delta V = (220)^2 \frac{(0.45)(7.2)(10)^{-4}(6.542-1)}{1 + (220)(0.45)(7.2)(10)^{-4}(6.542 + 1) + (220)^2(6.542)(A)}$$

$$\left[A = (7.7)^2 (10^{-4})^2 (.45)^2 \right]$$

$$= 55.36 \text{ fps}$$

$$W_c = 30.5 \text{ lb} = \text{Weight of canopy W/O free suspension lines}$$

$$\begin{aligned}
 Z &= 6 \text{ (working)} \\
 P_{\max} &= \text{breaking strength of suspension line} = 1000 \text{ lb} \\
 \epsilon_{\max} &= \text{maximum elongation of suspension line, ft} = 3 \text{ ft} \\
 P &= \sqrt{\frac{(30.5)}{(32.17)} (55.36)^2 (6) \frac{(1000)}{3}} \\
 &= \underline{\underline{2415 \text{ lb limit}}}
 \end{aligned}$$

Another peak loading condition occurs upon transition of the parachute configuration into the wing configuration. In the absence of a readily available method, the opening shock load is computed as the drag load on the wing at an angle of attack of 90° . The drag area is based on a drag coefficient for a flat plate and the flat plan area of the wing.

$$C_d = 1.28 \quad \text{Ref: Airplane Aerodynamics, Dommasch, Sherby, Connolly, Pitman Publishing Company, N.Y.}$$

$$S = \ell \frac{2}{K} \cos \Lambda = (22)^2 \cos 55^\circ = 257.6 \text{ ft}^2$$

$$\therefore (C_D S)_W = (257.6)(1.28) = 329.7 \text{ ft}^2$$

$$\text{Shock Force } D_F = \frac{1}{2} \rho V^2 (C_D S)_W$$

The velocity of the system at the instant of transition is calculated in the following manner.

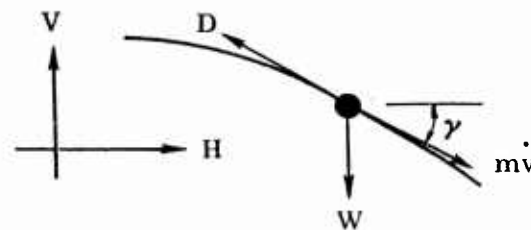

$$W = 300 \text{ lb}$$

$$m = \frac{300}{32.17} = 9.33$$

$$D = 1/2 \rho V^2 (C_D S)$$

$$\Delta t \quad t = 0:$$

$$V_H = 219.4 \text{ fps}, \quad V_x = 0,$$

$$\begin{aligned} \Sigma F_v = 0 &= D \sin \gamma - W - (-m\dot{v} \sin \gamma) \\ D \sin \gamma - W + m\dot{v} \sin \gamma &= 0 \end{aligned} \tag{1}$$

$$\begin{aligned} \Sigma F_H &= 0 = D \cos \gamma - (-m\dot{v} \cos \gamma) \\ D \cos \gamma + m\dot{v} \cos \gamma &= 0 \end{aligned} \tag{2}$$

$$\begin{aligned} \dot{V}_H &= \dot{V} \cos \gamma & \text{or} & \quad \dot{V} = \dot{V}_H / \cos \gamma \\ \dot{V}_v &= \dot{V} \sin \gamma & \text{and} & \quad \dot{V} = \dot{V}_v / \sin \gamma \end{aligned}$$

Substituting in eq. (1)

$$D \sin \gamma - W + m\dot{V}_v = 0$$

$$\begin{aligned} D &= (.5)(2.378)(10)^{-3} (146)V^2 \\ &= 0.174 V^2 \quad \text{but} \quad V^2 = \frac{V_v^2}{\sin^2 \gamma} \end{aligned}$$

$$\therefore D = 0.174 V_v^2 / \sin^2 \gamma$$

$$\text{Now} \quad 0.174 V_v^2 / \sin^2 \gamma - W + m \frac{dv_v}{dt} = 0$$

$$\text{Or} \quad \frac{m \, dV_v}{dt} = W - \frac{0.174 V_v^2}{\sin^2 \gamma}$$

$$\int \frac{d V_v}{W \sin^2 \gamma - 0.174 V_v^2} = \int \frac{dt}{m \sin \gamma}$$

$$\frac{1}{2 \sqrt{0.174 W \sin \gamma}} \quad \text{LN} \quad \frac{W \sin \gamma + V_v \sqrt{0.174 W \sin \gamma}}{W \sin \gamma - V_v \sqrt{0.174 W \sin \gamma}} = \frac{t}{m \sin \gamma} + C$$

When

$$t = 0, V_v = 0 \quad \therefore \quad C = 0$$

$$\therefore \text{LN} \quad \frac{W \sin \gamma + V_v \sqrt{0.174 W \sin \gamma}}{W \sin \gamma - V_v \sqrt{0.174 W \sin \gamma}} = \frac{2t \sqrt{0.174 W \sin \gamma}}{m \sin \gamma}$$

Since for LN $a = b$

$$a = e^b$$

$$\frac{W \sin \gamma + V_v (0.174 W \sin \gamma)^{1/2}}{W \sin \gamma - V_v (0.174 W \sin \gamma)^{1/2}} = e^{\frac{2t(0.174 W \sin \gamma)^{1/2}}{m \sin \gamma}}$$

Or

$$\frac{300 \sin \gamma + V_v (52.2 \sin \gamma)^{1/2}}{300 \sin \gamma - V_v (52.2 \sin \gamma)^{1/2}} = e^{\frac{2t (52.2 \sin \gamma)^{1/2}}{9.33 \sin \gamma}} \quad (3)$$

Substituting in eq (2)

$$D \cos \gamma + m \dot{V}_h = 0$$

$$D = 0.174 V^2 \quad \text{but} \quad V^2 = \frac{V_H^2}{\cos^2 \gamma}$$

$$\therefore D = 0.174 V_H^2 / \cos^2 \gamma$$

And

$$\frac{0.174 V_H^2}{\cos \gamma} + m \frac{d V_H}{dt} = 0$$

$$-\int \frac{dV_H}{V_H^2} = \int \frac{0.174 dt}{m \cos \gamma}$$

$$\frac{1}{V_H} = \frac{0.174 t}{m \cos \gamma} + C$$

when $t = 0$, $V_H = V_o = 219.4$ fps

$$\therefore C = \frac{1}{219.4} = 0.00457$$

$$V_H = \frac{9.33 \cos \gamma}{0.174 t + 0.0427 \cos \gamma}$$

Now, by means of equations (3) and (4), the velocity of the reefed system can be determined. Since the system is reefed for three seconds as a parachute, the velocities V_H and V_V can be found by an iterative process. In this analysis, time increments of 0.50 second were used and different values of flight path angle γ were assumed.

$$\begin{aligned} \text{The resultant velocity } V &= \frac{V_H}{\sin \gamma} = \frac{3.75}{\sin 84^\circ 46'} \\ &= 41.11 \text{ fps.} \end{aligned}$$

The terminal velocity V_T is found to be 41.6 fps as follows:
(Parachute configuration)

$$D = W = 1/2 \rho V^2 (C_o S)$$

$$(C_o S)_B = 5 \text{ ft}^2 \quad \text{Drag Area of Man}$$

$$(C_o S)_P = 141 \text{ ft}^2 \quad \text{Drag Area of Wing}$$

$$\therefore (C_o S)_T = 146 \text{ ft}^2 \quad \text{Total Drag Area}$$

$$V_T^2 = \frac{2 W}{\rho (C_o S)_T} = \frac{600}{2.378 \times 10^{-3} \times 146} = 1729$$

$$V_T = 41.6 \text{ fps}$$

Since the resultant velocity is approximately equal to the terminal velocity, the terminal velocity is used in calculating the shock force.

$$\begin{aligned} \text{Shock Force } D_F &= \frac{1}{2} \rho V^2 (C_o S)_W \\ &= (0.5)(2.378)(10)^{-3} (41.6)^2 (329.7) \\ &= \underline{\underline{678.4 \text{ lb limit}}} \end{aligned}$$

GUST LOADS

Method of Analysis

Ref: Mil-A-8629 (AER)

$$n_z = 1 + \frac{\rho V U_{\max} K_m}{2 (W/S)}$$

$$\rho = 2.378 \times 10^{-3} \text{ lb-sec}^2/\text{ft}^4 \quad @ \text{ S. L.}$$

$$U_{\max} = 50\sqrt{\sigma} = 50 \text{ fps at S. L.}$$

$$V = 50.57 \text{ fps} @ \alpha = 27.5^\circ$$

$$\frac{W}{S} = 1.08 \text{ lb/ft}^2$$

$$K_m = f(\mu) = \frac{0.88 \mu}{5.3 + \mu}$$

$$\mu = \frac{2 (W/S)}{g c m \rho}$$

$$g = 32.17 \text{ fps}$$

$$c = 14.7 \text{ ft.}$$

$$m = C_{N\alpha} = 2.292 \text{ (average)}$$

$$\mu = \frac{2 (1.08)}{(32.17)(14.7)(2.292)(2.378 \times 10^{-3})}$$

$$= 0.84$$

$$K_m = \frac{(0.88)(0.84)}{5.3 + 0.84}$$

$$= 0.1204$$

$$n_z = 1 + \frac{(2.378 \times 10^{-3})(50.57)(50)(1204)(2.292)}{2 (1.08)}$$

$$= 1 + .768$$

$$n_z = 1.768 \text{ g (Limit)}$$

The analysis indicates that the effects of gusts upon the system are relatively low. Because of its extreme flexibility, the paraglider is expected to act as a gust alleviator. In addition, the long nylon suspension cables will absorb some of the shock of a gust load. The preceding analysis has been conducted for a velocity of 50.57 fps. Although higher velocities would result in higher load factors for the same gust velocities, these higher glide speeds are not anticipated due to the danger of wing closure at smaller angles of attack.

The loads imposed upon the paraglider during one glide and flare will be quite small. High load maneuvers during glide are not anticipated, and the time histories of the flare (see Stability and Control Section) indicate a maximum load factor of 2g. The glide phase of the descent will consist of a straight glide and/or shallow turns as required for positioning over the intended landing site.

In view of the above discussion, the following structural design criteria are established for the glide and flare portions of the descent.

Gross Weight	300 pounds
Individual Weight	265 pounds
Design Limit Load Factor	2.0

Deployment of the wing into the glide configuration results in a momentary wing angle of attack of 90° . The data available from the wind-tunnel pressure tests of a model simulating a flexible wing have been analyzed for the loading distribution upon the wing structural members. Figure 14 shows the estimated load distribution on the keel and leading edges due to membrane load for two sweepback angles. The load distribution on the leading edges and that on the keel are practically identical, so each of the curves are valid for all three members. The curves show the loading distribution for the two sweepback angles to be very similar, and both approach a triangular distribution. The variation, with sweepback angle, of the c.p. location, percent wing load on keel, and centroid of airload on the structural members is shown in Figure 15. These parameters are shown to be essentially constant for the range of sweepback angle shown at 90° angle of attack. The data also show that the keel supports 50 percent of the wing load, and each leading edge carries 25 percent.

An estimate of the airload distribution on the wing during glide and flare was made by study of the pressure data made available by NASA. Figures 16 and 17 show the load distribution on the wing, keel, and leading edges.

DESIGN

Wing - General

The paraglider wing consists of three inflatable structural members, a flexible membrane, and an air inflation system (pneumatic system). The two leading edges and a keel constitute the inflatable members, all of which join at the prow apex to form a theoretical triangular wing planform. The keel runs longitudinally aft along the centerline of the wing from the apex to the trailing edge. See Figure 18.

A single inflatable air chamber is formed at the juncture of the three inflatable members. Inflatable members are circular tubes 6 inches in diameter and 22 feet long.

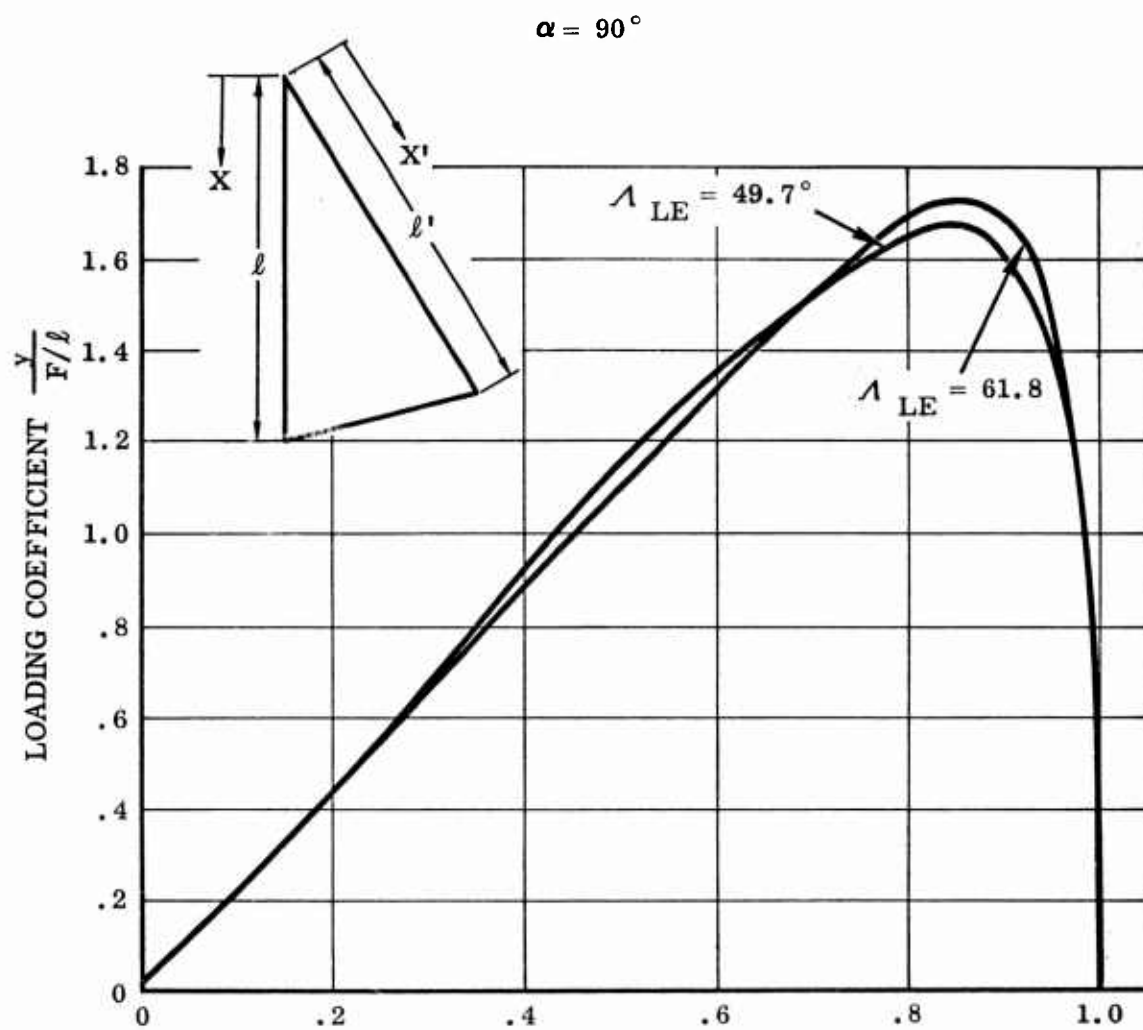

Figure 14 Theoretical Keel and Leading Edge Membrane Load Distribution
 $\alpha = 90^\circ$

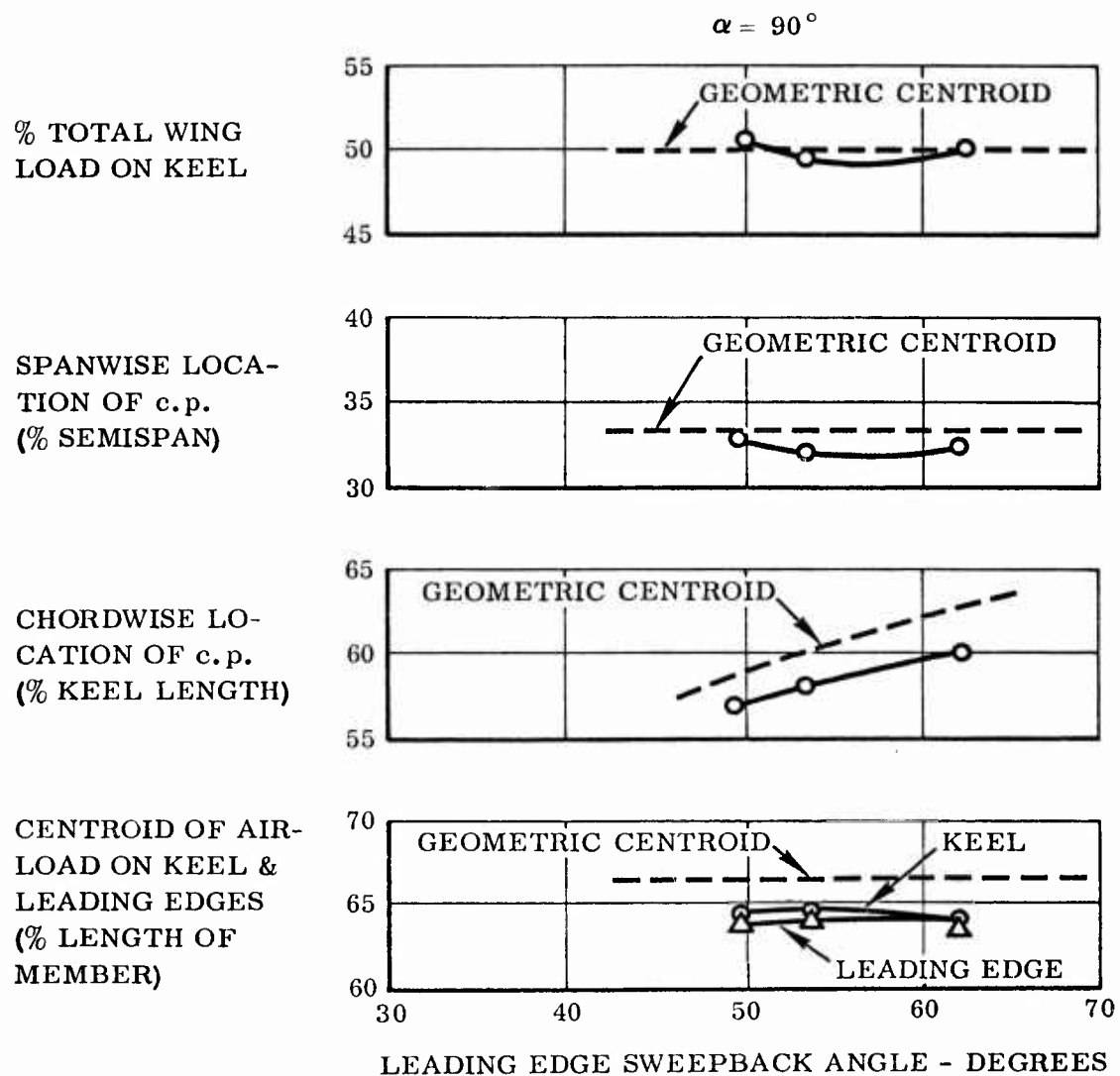

Figure 15 Theoretical Wing Airload Characteristics

$\alpha = 40^\circ$
 $\Lambda_{LE} = 45^\circ$ (FLAT)
 $\Lambda_{LE} = 61.8^\circ$ (FLIGHT)

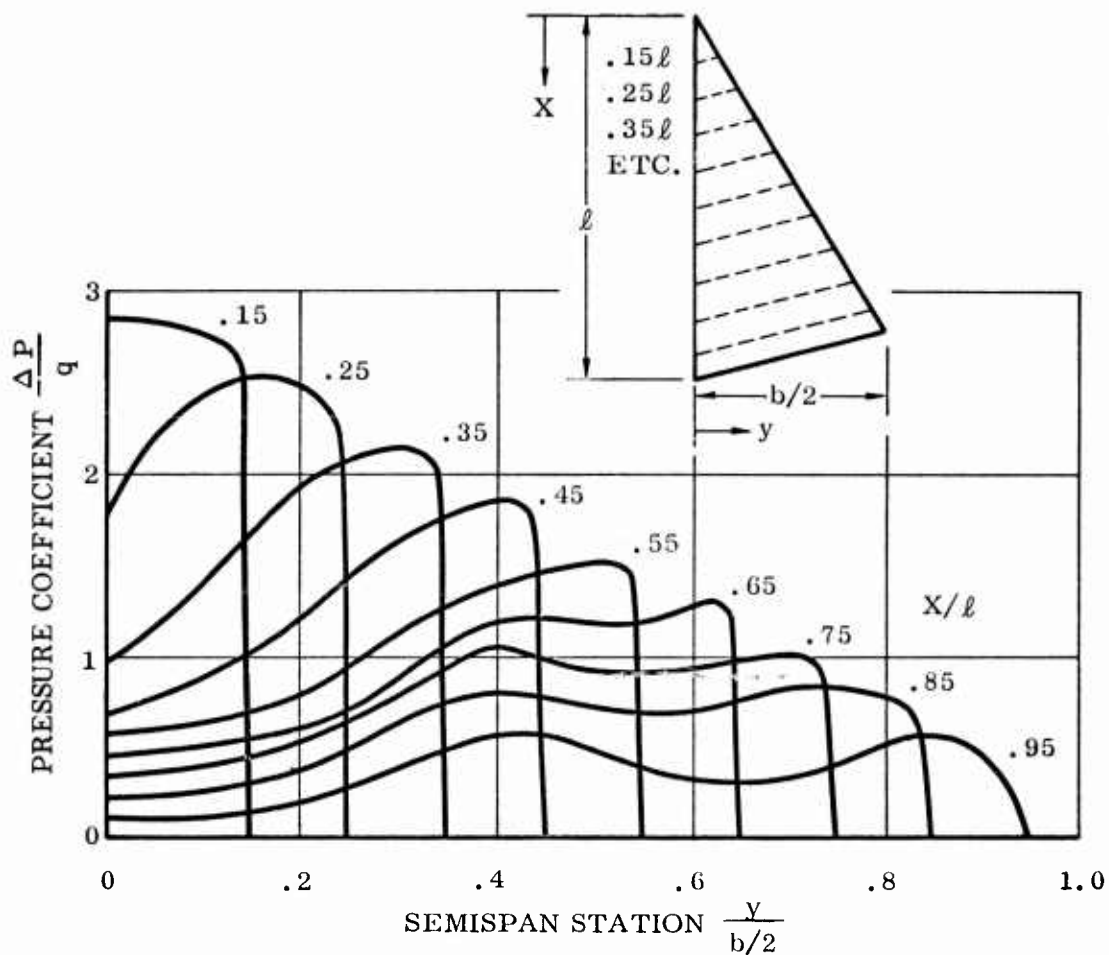
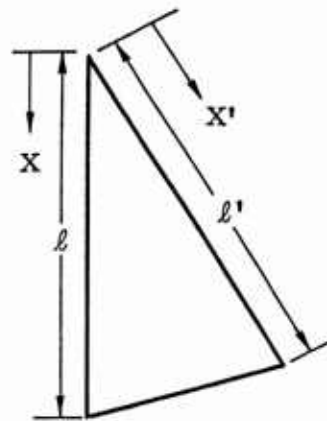

Figure 16 Theoretical Wing Airload Distribution



$\alpha = 40^\circ$
 $\angle_{LE} = 45^\circ$ (FLAT)
 $\angle_{LE} = 61.8^\circ$ (FLIGHT)

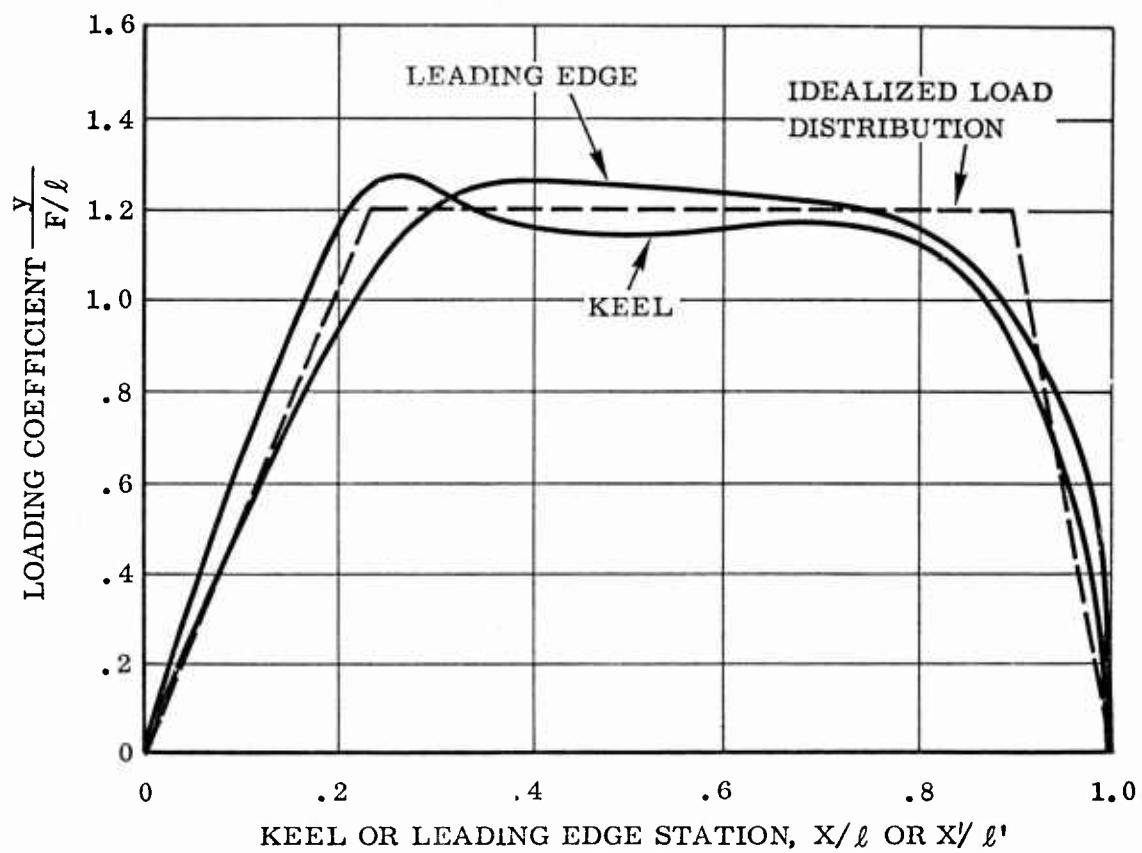

Figure 17 Theoretical Keel and Leading Edge Membrane Load Distribution
 $\alpha = 40^\circ$

A flexible membrane is continuously attached to the leading edges and keel. Wing area is 277.6 square feet in flat planform at a sweep angle of 55°.

Pneumatic system installation consists of a 125 cubic inch high pressure air bottle mounted in the aft end of the keel. A valve, actuated by a reefing cutter, releases the air into the inflatable leading edges and keel; this results in a tube pressure of approximately 5 psig when the bottle is initially charged to approximately 4,000 psig.

Fabric gussets with metal load bars and attachment eyelets are bonded to the leading edge membrane and the keel (Figure 18). These are used as attachment points for the lines of the suspension system.

Wing Numbers 1, 2, 3, and 4

These four wings were 13-point attachment wings (Figure 19) fabricated with a 2-ounce dacron base cloth coated on both sides with a 4222 polyester coating for an over-all material weight of 4.95 ounces per square yard.

The aft leading edge suspension lines were attached to an aluminum cone fairing which was an integral portion of the tube structure and distributed loads into the membrane via the tube.

The aft keel suspension line attachment point was on the pneumatic system installation clamp which secured the tube member to the pressure bulkhead on the pneumatic system, thereby distributing loads through the keel into the membrane.

Wing Numbers 5 and 6

These two wings were 13-point attachment wings (Figure 19) fabricated with 3.2 ounce dacron base cloth coated on both sides with a 4222 polyester coating for an over-all material weight of 7.95 ounces per square yard.

Suspension line attachment points were the same as serialized wings 1, 2, 3 and 4.

Wing Numbers 7, 8, and 9

These three wings were 16-point attachment wings (Figure 19) fabricated with the same material as serialized wings 5 and 6.

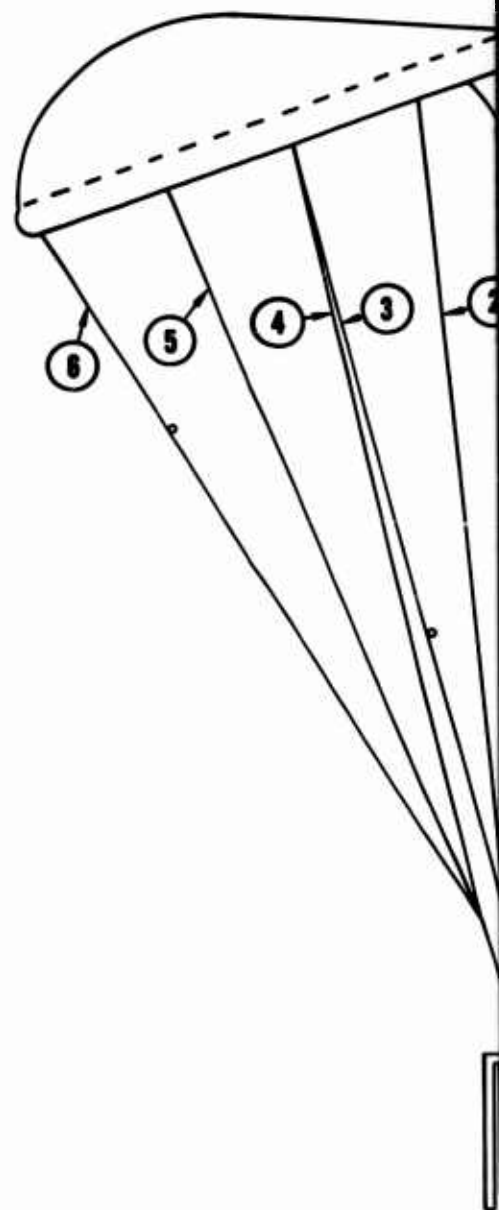
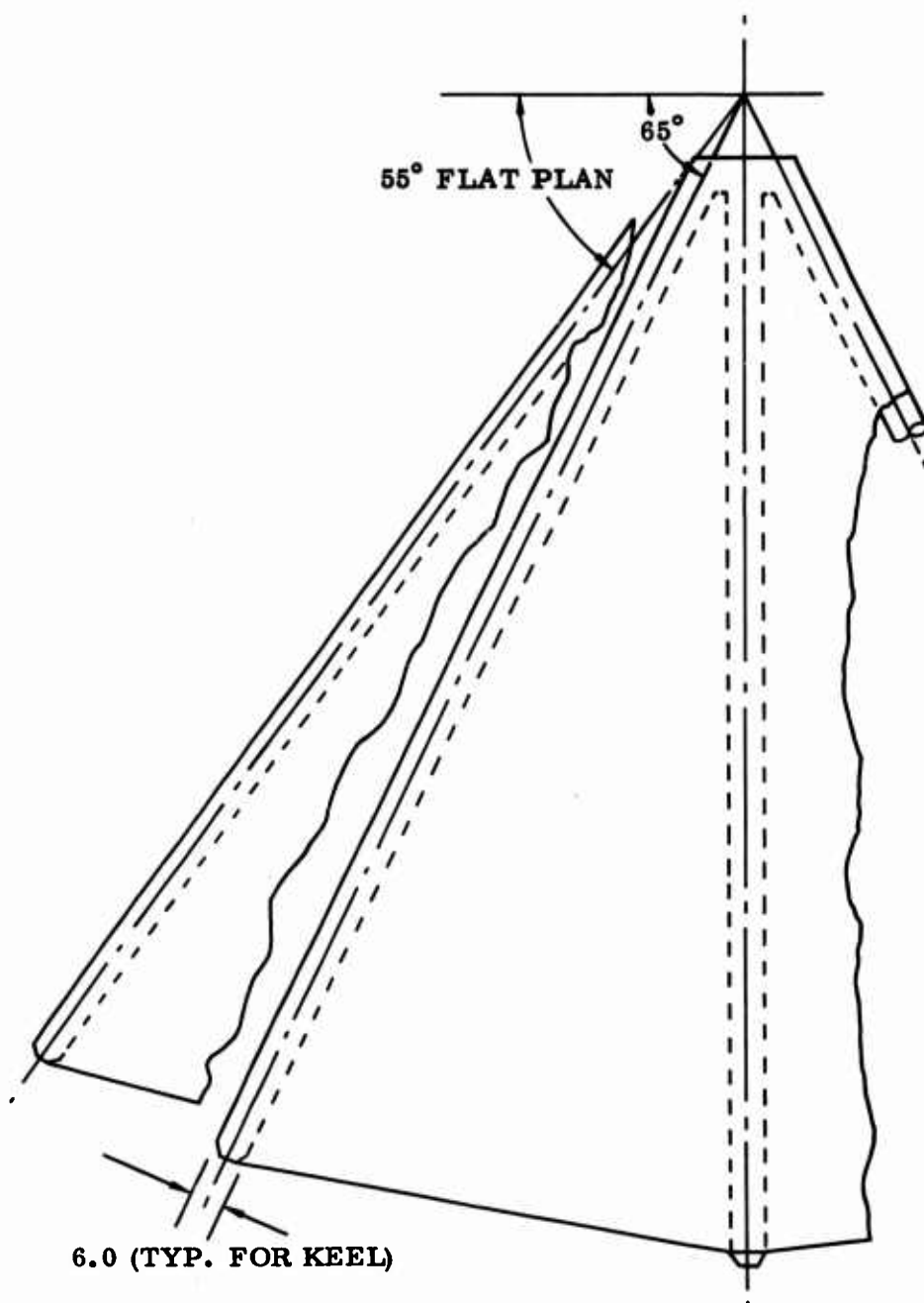

1

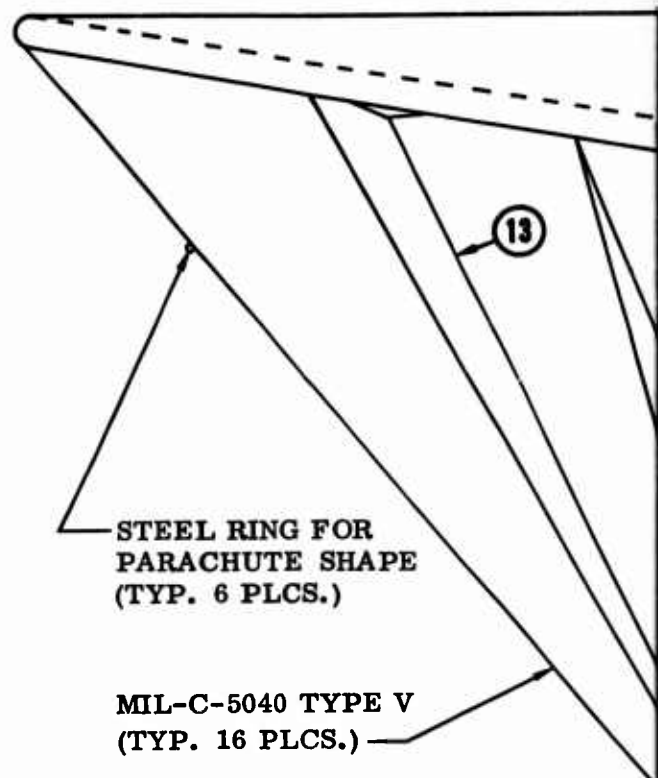
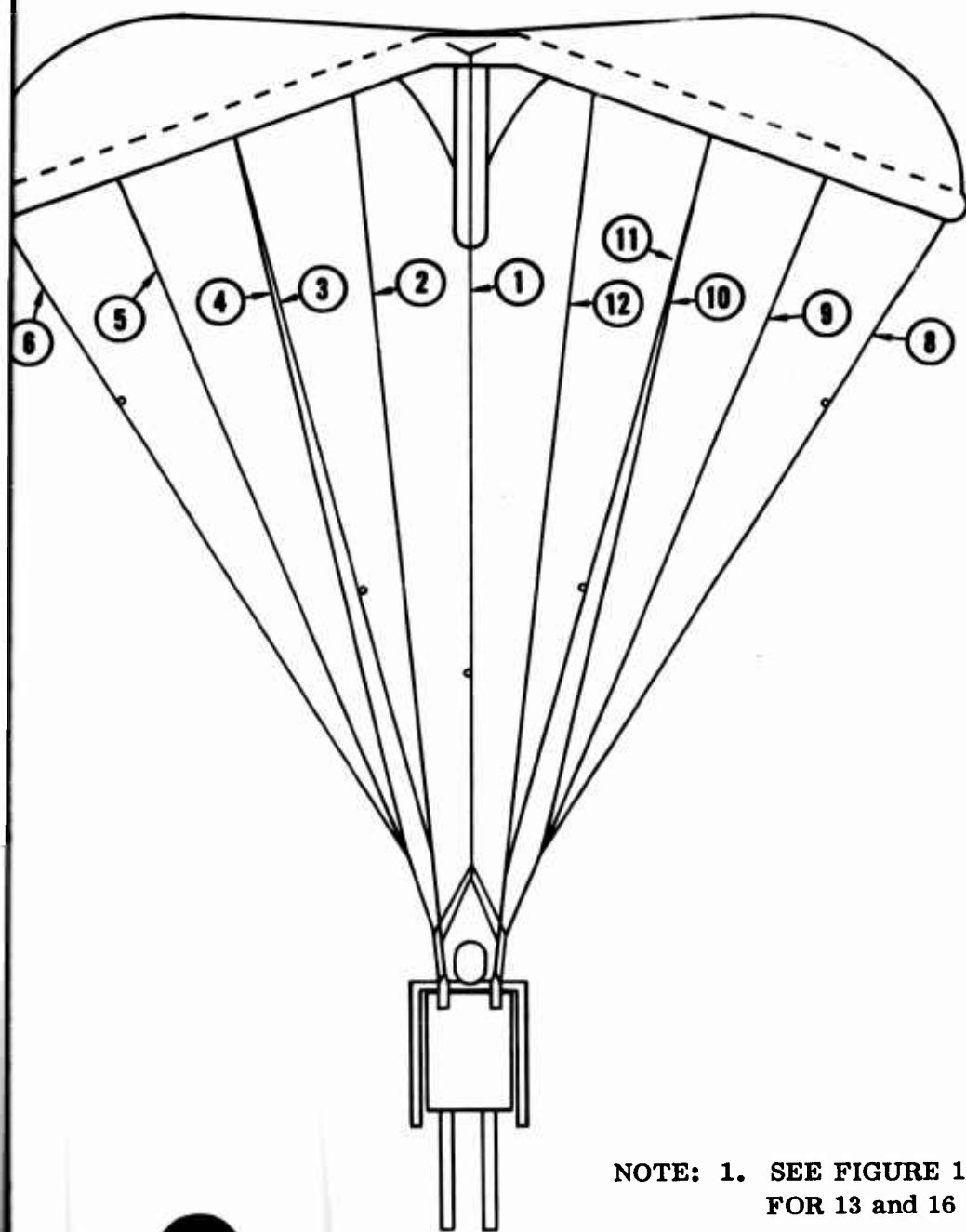

149C100 INSTRUMENTED DUMM
AND CONTROLS INSTALLATION

STANDARD CHEST
PACK FOR RECOVER

NOTE: 1. SEE FIGURE 19, SUSPENSION LINE NOMENCLATURE AND LOC
FOR 13 and 16 GUSSET WING LINE ARRANGEMENTS.

Figure 18 Gen

2

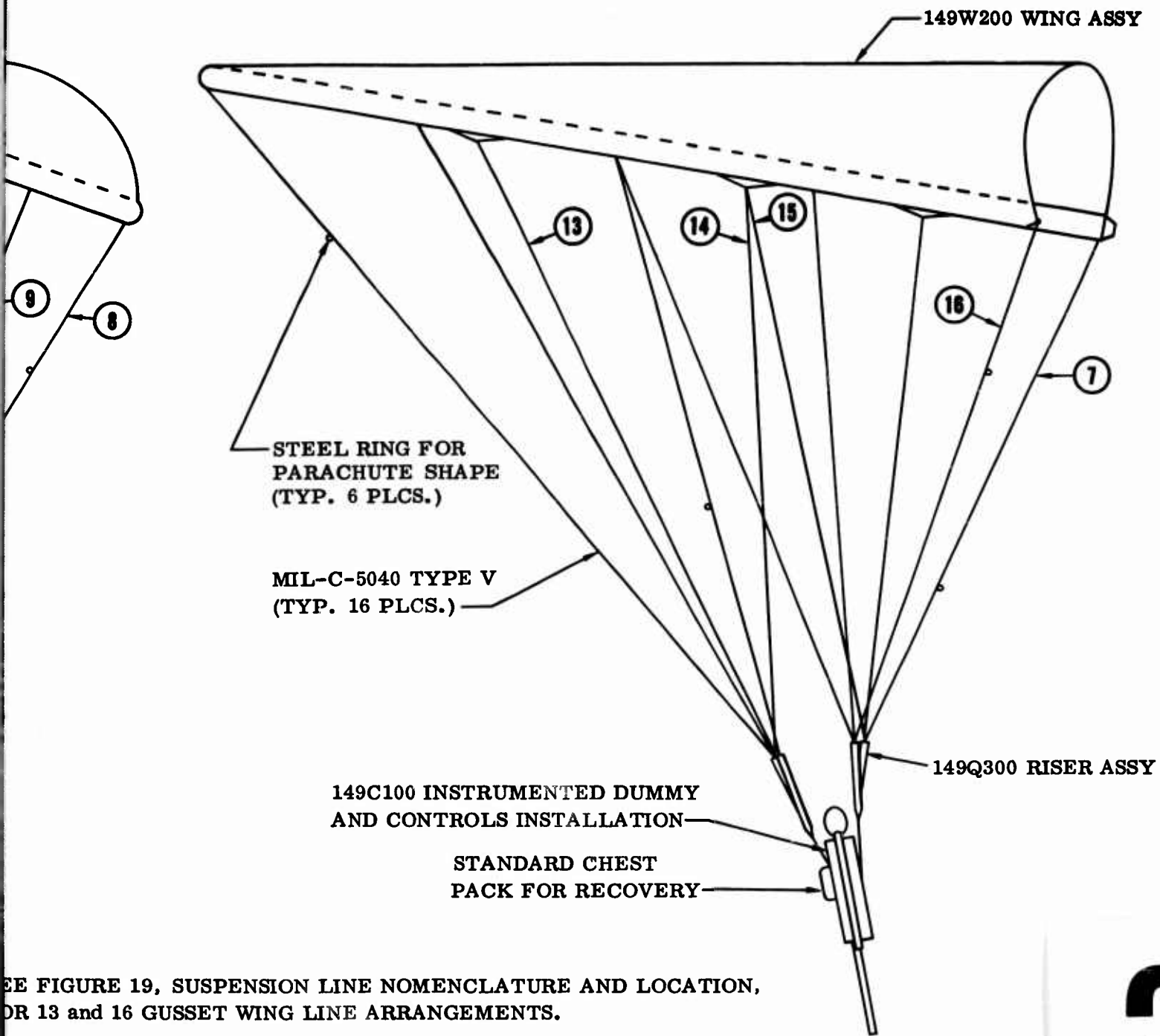

SEE FIGURE 19, SUSPENSION LINE NOMENCLATURE AND LOCATION, FOR 13 AND 16 GUSSET WING LINE ARRANGEMENTS.

Figure 18 General Arrangement Drawing

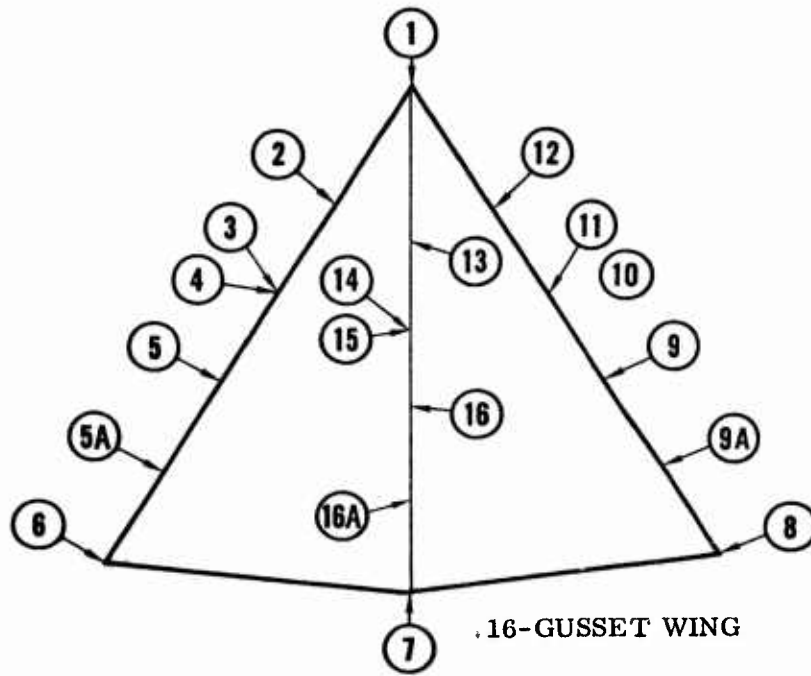
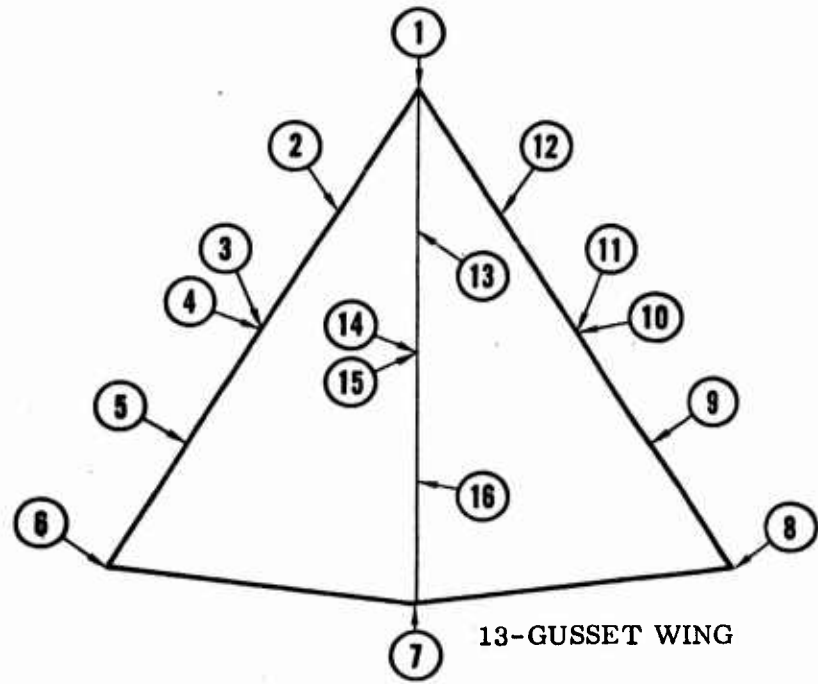

Figure 19 Suspension Line Nomenclature and Location

They also incorporated gusset attachment points on the aft leading edge attachment as well as the aft keel suspension line attachment.

On all previously fabricated wings 16 gussets were incorporated in order to distribute internal loading within the tube members more evenly in the area of higher wing loading in an attempt to have the wing hold its wing shape and glide when the tubes were not pressurized.

Later in the program, a 205-cubic-inch pressure vessel, which yielded 9 psig internal tube pressure when the bottle was charged to 3400 psig, was incorporated, on a loan basis, from another program. This was incorporated to help assist the wing when transitioning from the parachute mode into the glider mode by providing a more positive action and helping to alleviate any nose tucking tendencies.

Suspension System

The 13-gusset wing consisted of 16 suspension lines, while the 16-gusset wing has 19 suspension lines; in both cases the lines were attached to a set of four riser straps. The suspension lines are MIL-C-5040 Type V 1000-pound test nylon; the riser straps are MIL-W-4088 Type VII standard nylon parachute nylon webbing. All suspension lines are secured to the gussets on the wing and to the riser strap attachments by standard parachute knots. The riser strap assembly is fitted with a set of quick-disconnect latches (Capewell), enabling the system to be compatible with a standard T-10 personnel parachute harness.

Dummy

Three types of dummies were utilized during the course of the test program: a rope dummy, a moulded rubber torso dummy, and a nonarticulated steel dummy with installed instrumentation and control system.

The rope dummy, weighing 105 pounds, and the moulded torso dummy, with a weight range of 165 to 265 pounds, were used for qualitative tests during the developing and refining of a packing and deployment technique.

The third dummy system (Figure 20) was used for controlled flight and to obtain quantitative test data. This nonarticulated dummy housed the electrical-mechanical control system, a receiver-decoder for remote control, the electrical

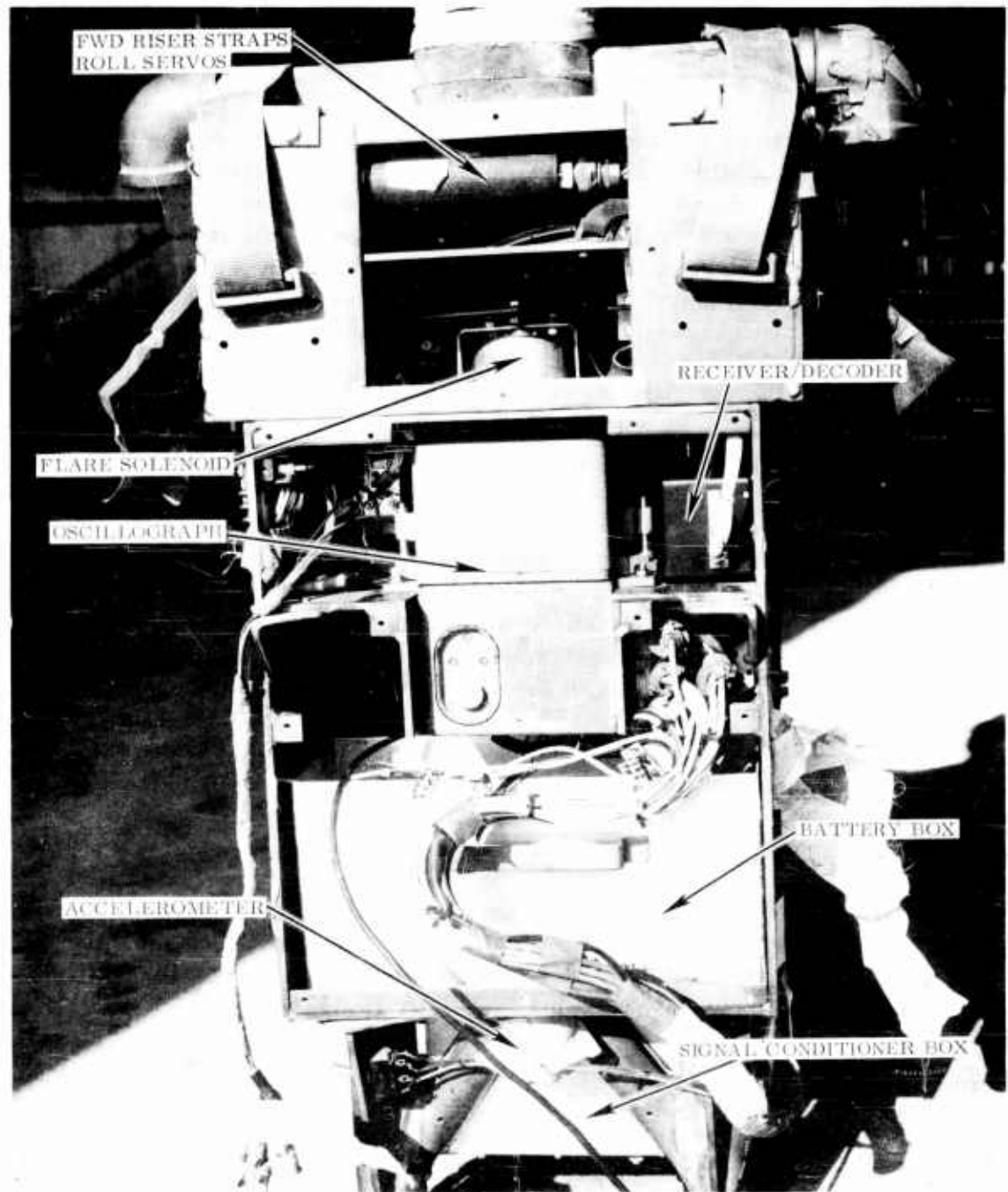

Figure 20 Instrumented Dummy, Instrumentation and Control System

power supplies, and the instrumentation system. Dummy weight could be varied from 215 to 265 pounds.

Control System

A remote-control radio system was used to control the glider during descent. The ground control station consisted of an ARW-55 transmitter coder and a remote control box. Electrical power was supplied by a gasoline-driven, 28-volt power supply system on a series of heavy-duty wet-cell batteries. The remote-control box is shown in Figure 21. This equipment was mounted in a two-wheel, military-type utility trailer. An Electronics Corporation Model 900-314 RS six-channel receiver/decoder, mounted in the lower torso portion of the dummy, completed the radio control link.

Lateral and longitudinal control was effected by shifting the suspended dummy weight with respect to the wing center of pressure. A turn was accomplished by shortening one and lengthening the other of the two rear riser straps. By simultaneously changing length of both of the rear riser straps, a longitudinal pitch change could be accomplished. The two rear riser straps were terminated in the upper portion of the dummy chest cavity and attached to circular drums, which were driven by reversible servo motors, (Globe Industries (C-67A-104). The remote-control servo motors are shown in Figure 22. Total change in riser strap length available for control of the system was approximately 6 inches.

Flare control for landing was actuated by an electric solenoid, Ledex (S-8209-022), which released the two forward risers and thereby increased their overall length up to 8 inches. The flare system could be actuated only once per flight.

A standard 24-foot reserve-type parachute was used on all instrumented dummy flights as an emergency parachute system. This parachute could be actuated by remotely firing an explosive bolt which released a preloaded bungee/cable system connected to the parachute ripcord.

Instrumentation System

A strain-gage load link was installed in each of the four riser straps to measure the shock loads experienced during the deployment sequence. Four 350-ohm temperature-compensated strain gages were used on each load link. A typical strain-gage circuit diagram is shown in Figure 23.

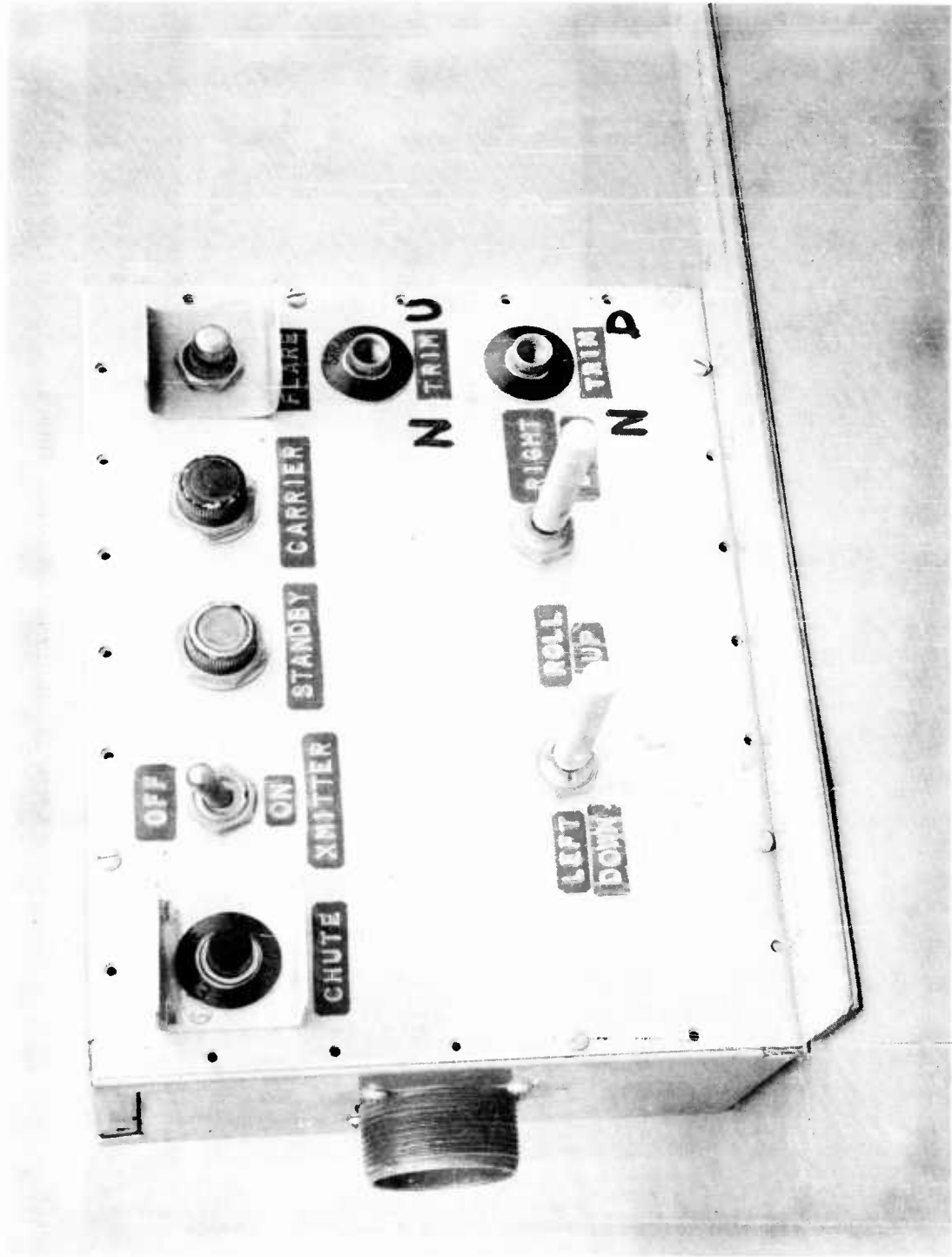

Figure 21 Ground Station Remote Control Box

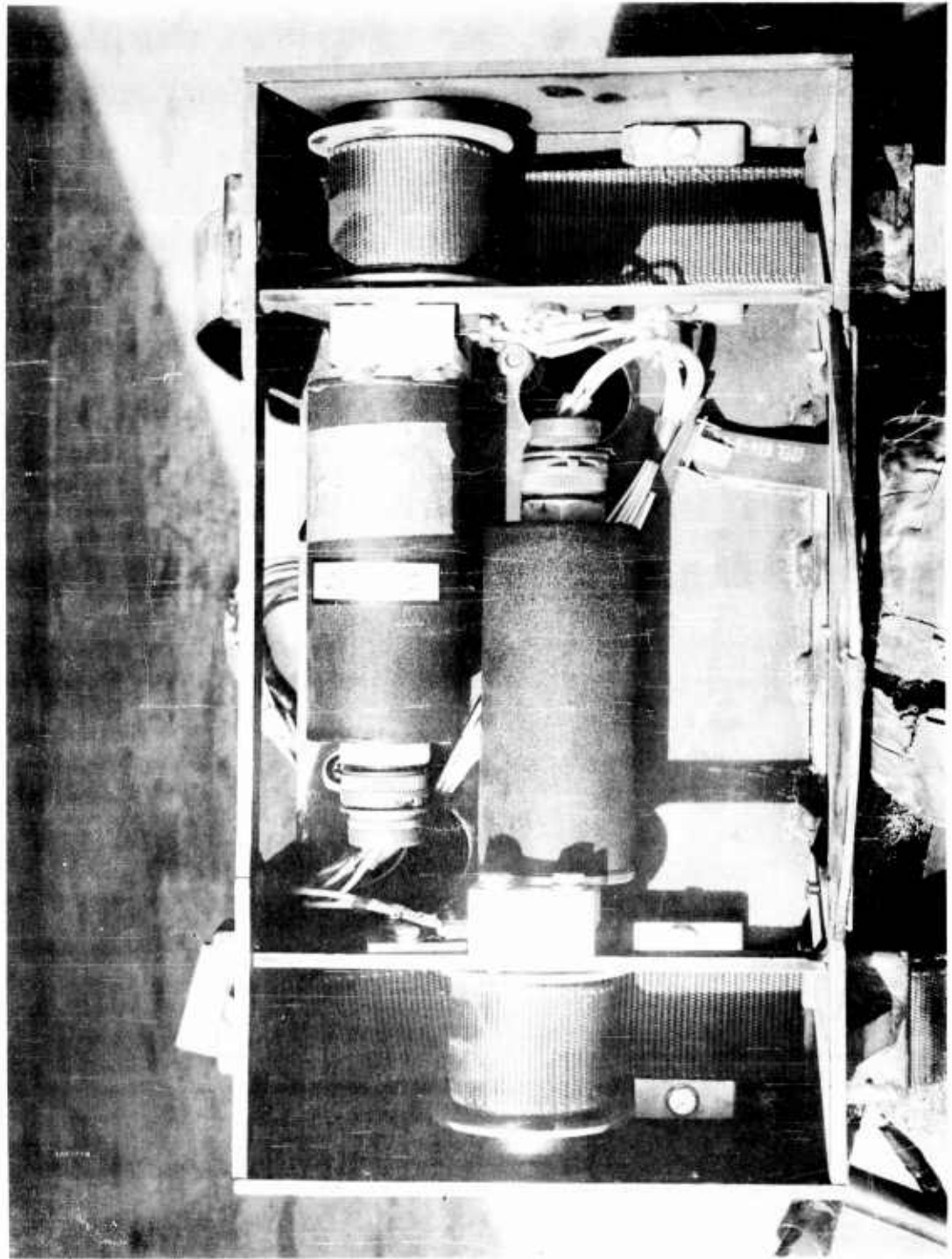

Figure 22 Roll Control Servo Motors

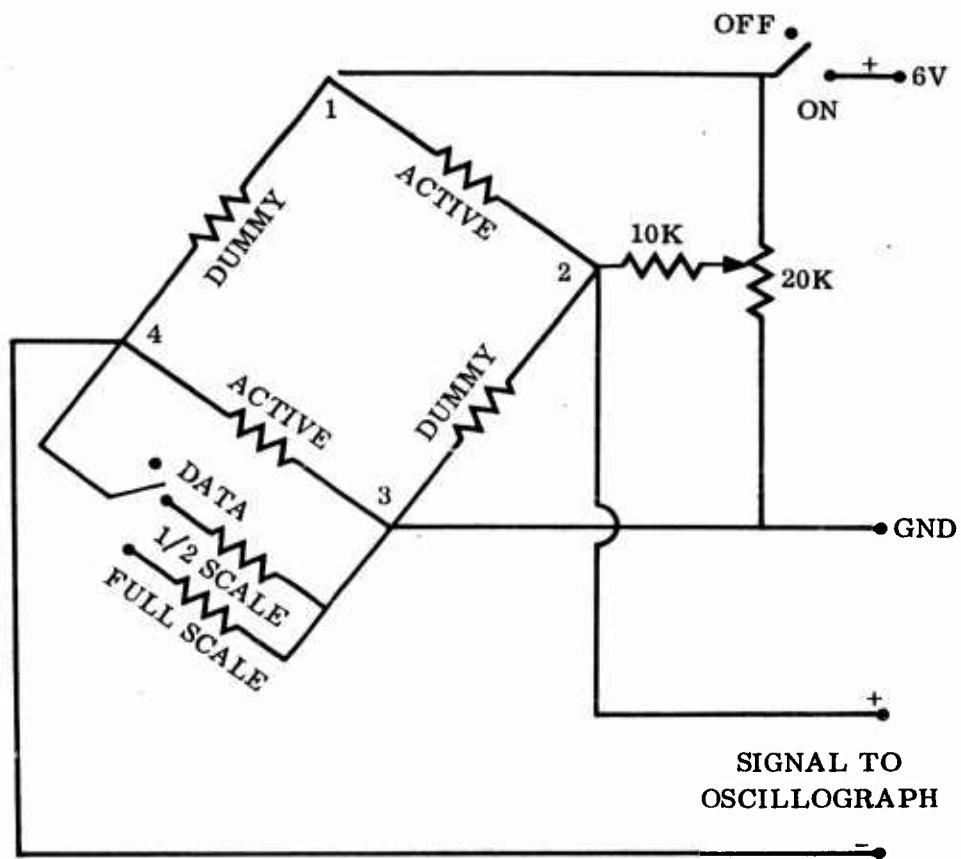

Figure 23 Strain Gage Circuit Diagram

Accelerations in both vertical and forward-and-aft directions were measured by accelerometers mounted on the dummy. An Edcliff Model 7-31 potentiometer-type accelerometer with a range of $\pm 10g$ was used to measure forward and aft accelerations. A Statham Model FA-15-350 linear accelerometer with a range of $\pm 30g$ was used for vertical acceleration measurements. A typical accelerometer circuit diagram is shown in Figure 24.

All data were recorded on a Consolidated Engineering Corporation Model 5-118 oscillograph mounted in the chest cavity of the dummy.

All electrical wiring for the instrumentation system and remote control system passed through a signal conditioner box. This unit housed the necessary trim and balance potentiometers, the calibration system, and the control switches. A typical circuit diagram for this unit is shown in Figure 25.

The cine-theodolite tracking system at the Yuma Test Station was used to obtain flight path performance data such as rate of descent, glide speeds, and landing velocities.

Two or three 16-mm movie cameras were used during each flight to obtain photographic coverage.

Meteorological data were obtained from the Signal Corps Meteorological Team at the Yuma Test Station. Balloon soundings were made after each drop test.

STRESS ANALYSIS (WINGS NO. 1, 2, 3)

Wing Analysis - Parachute Configuration

Limit opening shock load factor = 8.55g suspension line analysis

$$\text{Design load} = \frac{F_{0jc}}{Zuoek} \quad \text{Ref. WADC TR-55-265}$$

$$F = \text{Maximum opening force} = 265 \times 8.55 = 2270 \text{ lb}$$

$$c = \text{Factor for suspension line convergence angle} = 1.055$$

$$Z = \text{Number of suspension lines} = 6$$

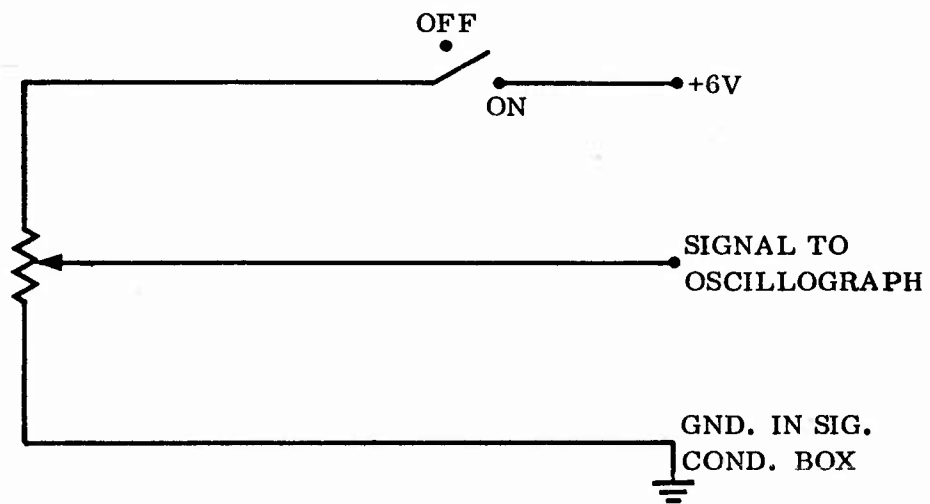

Figure 24 Accelerometer Circuit Diagram

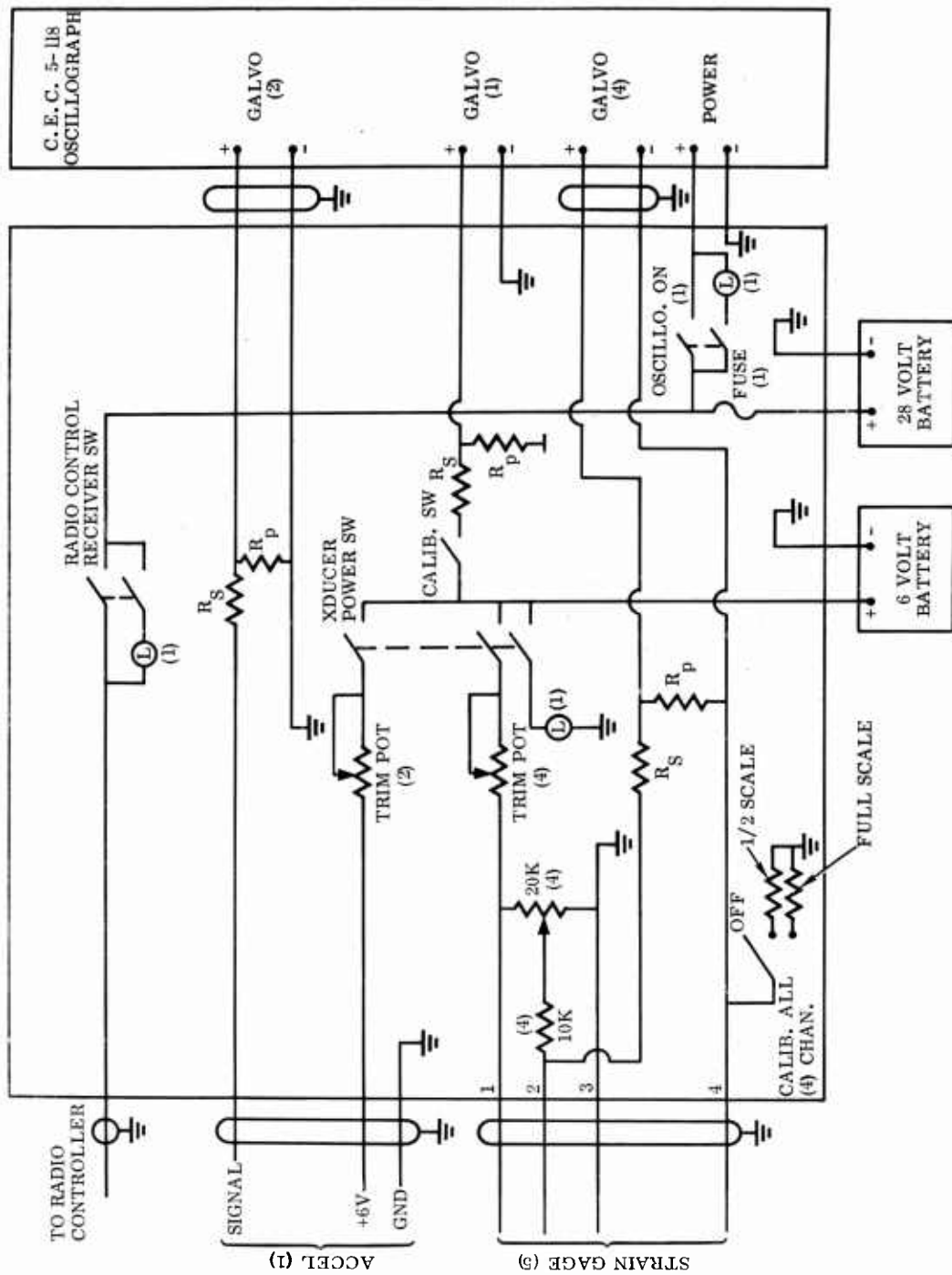

Figure 25 Circuit Diagram Signal Conditioner Box

$$\frac{J}{u_{oek}} = \text{Design factor} = 2.915$$

$$\text{Design load} = \frac{(2270)(2.915)(1.055)}{6}$$

$$= 1162 \text{ lb (ultimate)}$$

Nylon cord, coreless MIL-C-7515B(USAF) type V breaking strength = 1500 lb

$$\text{M. S.} = \frac{1500}{1162} - 1 = \underline{\underline{0.29}}$$

Membrane Analysis (Canopy)

The opening shock force is $F_o = 2564 \text{ lb Lim.}$ Therefore, the instantaneous canopy loading is

$$\frac{F_o}{C D_o S_o} = \frac{2564}{141.4} = 18.1 \text{ psf} = 0.126 \text{ psi (Limit)}$$

The maximum radius of the canopy is assumed to be equal to the distance from the top of the canopy to the suspension point. This distance is equal to 188 inches.

$$\begin{aligned} \text{The membrane hoop load} &= N_h = p R \\ &= (0.126)(188) \\ &= 23.7 \text{ lb/in Limit} \\ &= 47.4 \text{ lb/in Ultimate} \end{aligned}$$

The membrane material is a polyester-coated dacron cloth. The cloth weighs 5 oz./yd², is .006 inch thick, and has a strength of 100 lb/in warp and 100 lb/in in the fill direction.

$$\text{M. S.} = \frac{100}{47.4} - 1 = \underline{\underline{1.10}}$$

Wing Analysis - Glide Configuration

Limit opening shock load factor = 2.26g (This condition is critical for the glide phase of operation.)

Membrane Analysis (Canopy)

The opening shock force = (2.26)(300)

$$\begin{aligned}F_o &= 678.4 \text{ lb Limit} \\ &= 1356.8 \text{ lb Ultimate}\end{aligned}$$

$$\begin{aligned}\text{Area} &= l^2 \cos \Lambda_{LE} = (22)^2 \cos 55^\circ \\ &= 277.8 \text{ ft}^2 \text{ (Flat Plan)}\end{aligned}$$

Instantaneous canopy loading is given by

$$\begin{aligned}\frac{F_o}{C_{D_o} S_o} &= \frac{1356.8}{146} = 9.30 \text{ psf Ultimate} \\ &= 0.065 \text{ psi Ultimate}\end{aligned}$$

$$\text{Membrane radius} = 0.484 l_k = 0.484 \times 22 = 10.65 \text{ ft}$$

$$\text{Membrane hoop load} = 0.065 \times 10.65 \times 12 = 8.3 \text{ lb/in}$$

Parachute Configuration is More Critical

Suspension Line Analysis

The suspension lines are more critically loaded in the parachute configuration and, therefore, are not analyzed for this loading condition.

Wing Analysis - Keel and Leading Edges

The keel and leading edges of the wing are inflatable tubes fabricated from the same material as the wing membrane. The tubes are 6 inches in diameter

unpressurized. The keel and leading edges are similar in design. However, the keel is more highly loaded and will dictate the strength requirements.

The air-load distribution given in the structural criteria and loads section and represented in Figure 16 is utilized for determining the strength requirements. The distribution is based on the latest available wind-tunnel data. The actual distribution has been idealized for ease of analysis.

The inflated tubes are assumed to be hinged midway between the suspension lines. These segments are free bodied as simply supported beams. This assumption is made for ease of calculation. A previous analysis of the beam as a continuous beam on elastic supports shows the error to be insignificant.

The resultant load on the keel = $p = 0.43N$

Where

N = normal force on wing

$N = 1.06W$ (Resolution of lift and drag forces on wing)

$W = 300$ lb

$P = 0.43 (1.06) W$

$= 0.456 W$

$= 122$ lb

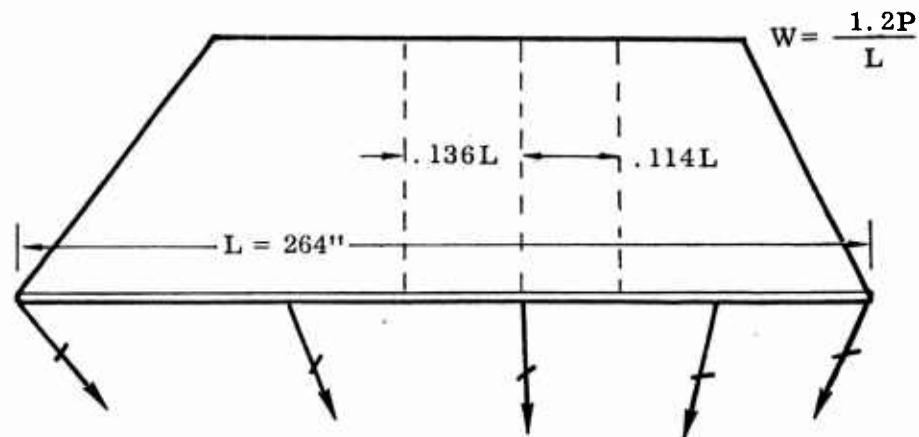

The maximum moment is given by

$$\begin{aligned} M_{\max} &= \frac{W x^2}{2} = \frac{1.2 p}{2 L} (.136L)^2 \\ &= 357 \text{ in/lb (i g)} \\ &= 357 (2) = 714 \text{ in/lb (2g Limit)} \end{aligned}$$

The diameter of the keel is 6 inches unpressurized. Tests conducted at Ryan have indicated that inflatable tubes fabricated from Dacron coated with polyester increase in diameter by 7 per cent when loaded to the yield strength of the material. Therefore, a 6-inch-diameter tube will work at a diameter of $6 + (.07 \times 6) = 6.42$ inches. Based on accumulated test data taken from flight tests of inflatable wings, the inflatable tubes are designed to theoretical collapse at limit load.

$$\therefore M = 714 \text{ in/lb (Design bending moment)}$$

The bending stress is given by

$$f_b = \frac{Mc}{I}$$

where

$$c = 0.698 R \text{ (includes effective adjacent material)}$$

and

$$I = 4.718 R^3 t \text{ (keel section)}$$

$$\therefore f_b = \frac{M(.698R)}{4.713R^3 t} = \frac{M(.698)}{4.713^2 t}$$

The longitudinal membrane stress is given by

$$\sigma_l = \frac{p R}{2 t}$$

To design for collapse at ultimate load, the bending compression stress is equated to twice the longitudinal membrane stress.

$$\frac{0.148 M}{R^2 t} = 2 \left[\frac{p R}{2 t} \right]$$

$$p = .148 \frac{M}{R^3} \quad (\text{internal pressure required})$$

$$= \frac{1071 (.148)}{(3.21)^3} = 4.8 \text{ psi required}$$

This pressure is somewhat conservative, in that the bending moment computed is conservative. If the relief of moment due to some degree of distribution of load by the cable gussets is taken into account, a slightly lower required pressure would result.

The internal pressure of 4.8 psi induces a hoop stress of $p \frac{R}{t}$ or a hoop load of $p R$.

$$N = pR = (4.8)(3.21) = 15.41 \text{ lb/in}$$

Not Critical

Keel Gusset Analysis

The critical load on the forward and aft keel suspension line attachments are derived from the parachute deployment condition. This force, as calculated on page 59, is

$$F_o = 1162 \text{ lb ultimate design load}$$

The intermediate keel gussets are loaded during the glide and landing phase only. This load is calculated from the basic assumptions made on page 61. The critical load is given by

$$F = \frac{(0.136L + 0.114L)}{1} \frac{1.2 P}{L} \quad (\text{Ref. Pg. 44 Figure 17, Loads \& structural analysis section.})$$

$$= 36.6 \text{ lb (18)}$$

$$= 73.2 \text{ lb limit}$$

$$= 109.8 \text{ lb ultimate}$$

Nose Gussets:

$$F_o = 1162 \text{ lb ultimate}$$

This load is transmitted to or from the wing structure by two gussets. The gussets make an angle of approximately 30° to the line load path. Therefore, the resolved load per gusset is given by

$$F_G = \frac{F_o}{2 \cos 30^\circ} = \frac{1162}{2 \cos 30^\circ}$$
$$= 670 \text{ lb per gusset}$$

Although the load bar is glued to the gusset, it is conservatively assumed that the total load is transmitted by the load bar, bearing on the fabric.

Total load Bar Force = 670 lb

load bar length = 2 inches

$$\therefore W = 670/2 = 335 \text{ lb/in at point A}$$

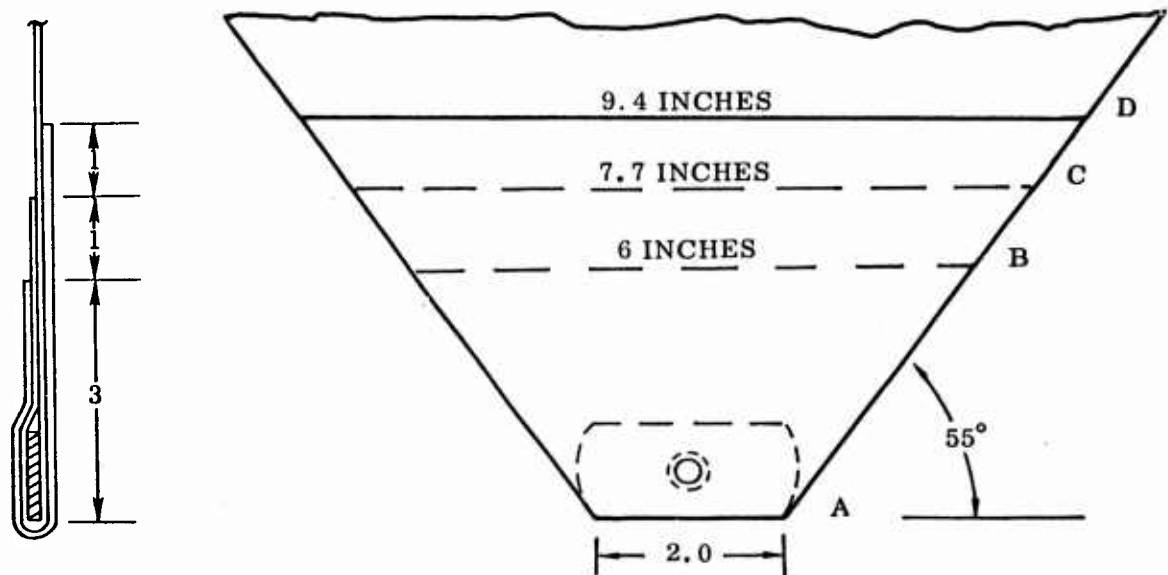

Net Tension at Point A

$$\text{Load} = 335 \text{ lb/in}$$

$$\text{Allowable} = (100)^*(4)** = 400 \text{ lb/in}$$

$$\text{M. S.} = \frac{400}{335} - 1 = \underline{\underline{0.19}}$$

Net Tension at Point B

$$\text{Load} = \frac{670}{6} = 111.7 \text{ lb/in}$$

$$\text{Allowable} = (100)(3) = 300 \text{ lb/in}$$

$$\text{M. S.} = \frac{300}{111.7} - 1 = \underline{\underline{1.68}}$$

Section at point C is not critical by observation.

$$\text{At point D the load} = \frac{670}{9.4} = 71.3 \text{ lb/in}$$

$$\text{Allowable} = 100 \times 1 = 100 \text{ lb/in}$$

$$\text{M. S.} = \frac{100}{71.3} - 1 = \underline{\underline{.40}}$$

* Four layers of cloth

** Allowable load per inch for dacron cloth (5.0 ounces/yd)

Hoop tension in fabric at load bar:

$$N = \text{hoop load/inch}$$

$$= p R$$

$$p = \frac{670}{(2)(.063)} = 5317 \text{ psi}$$

$$R = t/2 = 0.0315 \text{ inch}$$

$$N = (5317)(0.0315) = 167.5 \text{ lb/in}$$

$$\text{Allowable hoop load} = (100)(2) = 200 \text{ lb/in}$$

$$\text{M. S.} = \frac{200}{167.5} - 1 = \underline{\underline{0.19}}$$

Gusset Shear Strength (Adhesive)

The adhesive utilized in the fabrication of the paraglider is a 3M EC-2135 resin and EC-2134 catalyst. Tests conducted at the Ryan Aeronautical Company indicated that a minimum shear strength of 44 psi may be used for design. However, from experience and tests, the strength of these joints exceeds the strength of the parent material. For this reason, an analysis is not made for this glue joint.

Intermediate Gussets

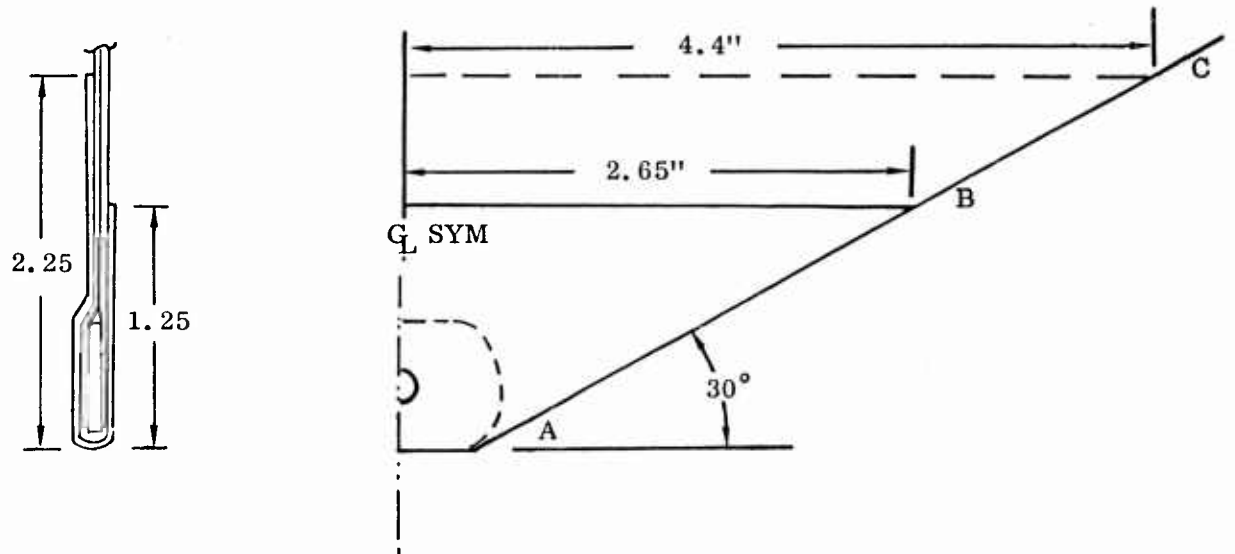

Net tension at point A

$$F \cong 110 \text{ lb/ultimate}$$

$$P_{\text{allow}} = 400 \text{ lb}$$

$$\text{M. S.} = \underline{\text{High}}$$

Points B & C not critical by observation.

Leading Edge Tail Cone

Lug Analysis:

Ref: "Product Engineering" May 1950

149W200 - 3 tail cone fitting

Lug Analysis Material: 6061-T6 Aluminum Sheet

$$W = 0.76 \quad \frac{W}{D} = \frac{0.76}{.194} = 3.92 \quad \frac{D}{t} = \frac{0.194}{0.125} = 1.55$$

$$D = 0.194$$

$$a = 0.38 \quad \frac{a}{D} = \frac{.272}{.194} = 1.40$$

$$t = 0.125$$

$$A_{BR} = Dt = (0.194)(0.125) = 0.0243 \text{ in}^2$$

$$A_t = (W-D)t = (0.76-0.194) 0.125 = 0.0708 \text{ in}^2$$

$$P_{tu} = K_t F_{tu} A_t \text{ (tension - net section)}$$

$$K_t = f(W/D) = 0.30$$

$$= (0.30)(42,000)(0.0708) = 893 \text{ lb allowable}$$

$$P_{BR_u} = K_{BR} A_{BR} F_{tu} \text{ (shear-bearing)}$$

$$K_{BR} = f(a/D, D/t) = 1.3$$

$$= (1.3)(0.0243)(42,000) = 1328 \text{ lb allowable}$$

$$P_y = C \frac{F_{ty}}{F_{tu}} P_{\min} \quad P_{\min} = P_{tu} = 893 \text{ lb}$$

$$C = \frac{P_{\min}}{A_{BR} F_{tu}} = 893/1020 = 0.87$$

$$P_y = (0.87) \frac{(35,000)}{(42,000)} (893) = 647 \text{ CB (lug yield allowable)}$$

The load which is calculated in the following analysis differs from that on the apex suspension point in that the apex load includes a nonmetallic fitting factor. Since the aft cone is aluminum, the fitting factor is not included.

$$\begin{aligned} \text{Opening shock force} &= 2564 \text{ lb limit} \\ &= 3850 \text{ lb ultimate} \end{aligned}$$

$$\text{Load per line} = \frac{3850}{6} = 640 \text{ lb ultimate}$$

$$\text{Line convergence factor} = 1.055$$

$$\therefore \text{Load per line} = 640 \times 1.055 = 675 \text{ lb}$$

$$\text{M. S.} = \frac{640}{675} - 1 = \underline{\underline{-0.04}}^*$$

* Verify results of static test to negative margin

Leading Edge Tail Cone

The leading edge tail cone fitting is glued inside the dacron cone. There is an external dacron doubler to increase the hoop strength and to decrease the elongation. Any excessive elongation in the hoop direction may allow the tail cone fitting to slip out if the glue does not insure a positive attachment.

$$\text{The tail cone load} = 675 \text{ lb}$$

$$\begin{aligned} \text{hoop load} &= \frac{675}{\pi D} \left(\frac{6}{7}\right) + 4.8 (1.3) \\ &= 77.3 \text{ lb/in} \end{aligned}$$

$$\text{elongation } e = \left(\frac{77}{200}\right) (0.07)(\pi D) = 0.220$$

$$\text{diametrical increase} = \frac{\pi D + .220}{\pi} = 2.68 \text{ in}$$

$$\text{Original diameter} = 2.60 \text{ in}$$

Not Critical

$$\text{Hoop allowable} = (2)(100) = 200 \text{ lb/in}$$

$$\text{M. S.} = \frac{200}{77.3} - 1 = \underline{\underline{\text{High}}}$$

Longitudinal Membrane Load

$$= \frac{675}{\pi D} \left(\frac{7}{9.21} \right) + \frac{(4.8)(1.3)}{3} = 66.1 \text{ lb/in}$$

Not Critical

The tail cone and tube on the leading edge is attached by means of "finger" doublers. The effective shear lap area is approximately one-half of the circumference times the lap dimension. Additional external doublers are applied longitudinally to strengthen the joint further. These doublers are 1 inch wide and 4 inches long. The total shear strength of the joint is

$$P_{\text{allow}} = \left[\left(\frac{1}{2} \right) (\pi D)(1) + (8)(1)(2) \right] 44$$

$$= 1118 \text{ lb Shear Allowable}$$

Conservatively assuming that all of the tail cone fitting load is carried by the leading edge tube gives

$$P = \frac{p R}{2} + 675 = \frac{(4.8)(3.21)}{2} + 675$$

$$= 682.7 \text{ lb}$$

$$\text{M. S.} = \frac{1118}{682.7} - 1 = \underline{\underline{0.63}}$$

Membrane Splice (2 in Lap)

$$P_{\text{allow}} = (2)(44) = 88 \text{ lb/in}$$

$$P = 47.4 \text{ lb/in (Ref. Pg. 59)}$$

$$\text{M. S.} = \frac{88}{47.4} - 1 = \underline{\underline{0.86}}$$

Keel Tail Cone

All parts aft of the rear bottle mount are not structurally loaded. Therefore, they are not analyzed.

149W200-39 Mount

Not Critical by Inspection

149W200-51 Mount

Not Critical by Inspection

MS20115-3 Shackle

Load = 675 lb ultimate

Allowable = 920 lb

$$M. S. = \frac{920}{675} - 1 = \underline{\underline{0.36}}$$

Leading Edge Suspension Line Bridles

Hoop load in bridle = p R

Load on L. E. = (0.25)(1.06)(300)

= 74.25 lb (lg)

= 238 lb (ultimate)

Maximum distributed load = $\frac{1.2 F}{L} = \frac{(1.2)(238)}{(22)(12)} = 1.08 \text{ lb/in}$

Line load = (1.08)(0.250)(22)(12)

= 71.2 lb ultimate

$$p = \frac{71.2}{1} = 71.2 \text{ lb/in}^2$$

Hoop load = (71.2)(.50) = 35.6 lb/in

Allowable line load = 1200 lb

$$\text{M. S. } \frac{1200}{35.6} - 1 = \underline{\text{High}}$$

$$\text{Resolved bridle load} = \frac{71.2}{2 \cos 30^\circ} = 41 \text{ lb}$$

Not Critical

Apex Analysis

An analysis of the apex design has not been included in this report. Time limitations and the extreme complexities of the detail design do not make practical an analysis at this time. To substantiate the structural integrity of the apex design, adequate static and dynamic tests will be conducted.

149Q300-7 Fitting

Assume webbing effective width = 60% of true width

$$\text{Webbing width} = 1.72 \text{ in}$$

$$\therefore \text{Effective width} = (1.72)(.60) \approx 1.0 \text{ in}$$

Weight of man = 265 lb gross weight

$$n_Z = 12.83 \text{ g's ultimate}$$

$$\therefore F_{\text{total}} = 12.83 \times 265 = 3400 \text{ lb ultimate}$$

Since there are two fittings, both are assumed to be effective instantaneously.

$$\therefore \text{Load/link} = \frac{(3400)}{2} = 1700 \text{ lb/link}$$

The strap load must be transmitted by a beam-type design which has fixed end supports.

$$M_{\text{max}} = 390 \text{ in/lb ultimate (uniform load on fixed beam)}$$

$$f_b = \frac{6M}{b d^2} = \frac{(6)(390)}{(.125)(.375)^2} = \frac{2340}{0.0176} = 133000 \text{ psi (ultimate)}$$

$$F_{tu} = 125000 \text{ psi minimum 4130 H. T. } 125000-145000 \text{ psi}$$

$$F_b = (1.5)(125000) = 187500 \text{ psi}$$

$$M. S. = \frac{187500}{133000} - 1 = \underline{\underline{0.13}}$$

149Q300-9 Arm

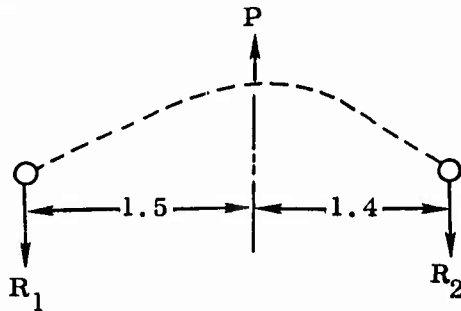

$$R_1 = 0.483 P$$

$$P = 1700 \text{ lb ultimate}$$

$$R_1 = (.483)(1700) = 822 \text{ lb ultimate}$$

$$R_2 = 1700 - 822 = 878 \text{ lb ultimate}$$

$$M = (878)(1.4) = 1210 \text{ in/lb}$$

$$f_b = \frac{6 M}{b d^2} = \frac{(6)(1210)}{(.25)(.50)^2} = 116000 \text{ psi}$$

$$M. S. = \frac{187500}{116000} - 1 = \underline{\underline{0.61}}$$

Monel Rivet

Shear allowable = 1720 lb.

Not Critical

Mechanical Dummy

Generally speaking, the dummy structure has been designed with adequate strength and does not require theoretical substantiation of strength. However, some of the more critical items for the successful operation of the system are given a cursory examination.

Dead-ended Aft Riser Strap

Critical loads are developed during parachute deployment sequence.

Total load = 3850 lb ultimate (Ref. Pg. 68)

$$\text{Load per riser} = \frac{3850}{4} = 962.5 \text{ lb ultimate}$$

Allowable load = 2400 lb.

Emergency Chest Pack Condition

In the event of a malfunction in the paraglider system, an emergency chest pack parachute, 28 feet in diameter, is provided. For the purposes of this analysis, it is assumed that the man reaches terminal velocity without the drag of a reefed or inoperative paraglider system.

$$V_T^2 = \frac{2W}{\rho(C_D S)}$$

$$W = 265 \text{ lb}$$

$$\rho = 2.378 \times 10^{-3}$$

$$C_D S = 5 \text{ ft}^2$$

$$V_T^2 = \frac{(2)(265)}{(2.378 \times 10^{-3})(5)} = 44500$$

$$V_T = 210 \text{ fps}$$

$$\text{Snatch force} = P = \sqrt{\frac{W_c}{g} \Delta V^2 z \frac{P_{\max}}{E_{\max}}}$$

$$W_c = 15 \text{ lb}$$

$$g = 32.17 \text{ fps}$$

$$z = 24$$

$$P_{\max} = 500 \text{ lb}$$

$$E_{\max} = (0.40)(.85)(28) = 9.5 \text{ ft.}$$

$$\Delta V = V_o^2 \frac{t K_b (n-1)}{1 + V_o t K_b (n+1) + V_o^2 n K_b^2 t^2}$$

$$C_{D_o} S_o = 3.5 \text{ ft}^2$$

$$\gamma = 0.0766 \text{ lb/ft}^3$$

$$K_p = \frac{(3.5)(0.0766)}{(2)(15)} = 0.0089$$

$$(C_D S)_B = 5 \text{ ft}^2$$

$$W_B = 265$$

$$\gamma = 0.0766 \text{ lb/ft}^3$$

$$K_B = \frac{(5)(0.0766)}{(2)(265)} = 0.00072$$

$$n = \frac{K_p}{K_B} = \frac{0.0089}{0.00072} = 12.36$$

$$d = 28 \text{ ft.}$$

$$t = 0.7 \text{ seconds}$$

$$\begin{aligned} \therefore \Delta V &= (210)^2 \frac{(0.5)(0.00072)(12.36-1)}{1 + (210)(.5)(.00072)(12.36 + 1) + (210)^2(12.36)(.00072)^2(.5)^2} \\ &= 86.5 \text{ fps} \end{aligned}$$

$$P = \sqrt{\frac{(15)}{(32.2)} (86.5)^2 (24) \frac{(500)}{(9.5)}}$$

= 2100 lb snatch force, limit (28 ft parachute)

Opening Shock Force

Ref: WADC TR 55-265

$$F_o = C_{D_o} S_o q_s X K$$

$$t_f = 8 D_o / V_s^{0.9} \quad (\text{filling time})$$

$$= \frac{(8)(28)}{(210)^{0.9}} = 1.87 \text{ seconds}$$

$$\text{Factor A} = \frac{2 W_t}{C_{D_o} S_o V_s \rho t_f g}$$

$$= \frac{(2)(265)}{(0.75)(\pi)(14)^2(210)(2.378 \times 10^{-3})(1.87)(32.2)}$$

$$= 0.0382$$

$$\therefore X = 0.068$$

$$\text{Opening Shock Force } F_o = (0.75)(\pi)(14)^2(.50)(2.378 \times 10^{-3})(210)^2(.068)(1.4)$$

= 2300 lb limit (28 ft parachute)

The 28-foot-diameter reserve parachute deployment loads are less critical than the paraglider system loads, therefore, additional analysis is not made for these loads.

Servo Torque Margin

The servo will be operated during the glide and landing phase of the flight. The design limit load factor is 2g. For this condition, the riser lines carry a force of

$$F = \frac{(2)(265)}{4} = 132.5 \text{ lb limit}$$

$$\begin{aligned} \text{Torque exerted on drum} &= (132.5)(.90) \\ &= 119 \text{ in/lb} \end{aligned}$$

Assuming that control is initiated only during 1g equilibrium flight,

$$F = 66.25 \text{ lb limit}$$

$$T = (66.25)(.90) = 59.6 \text{ in/lb}$$

$$\text{Servo output} = 100 \text{ in/lb @ 1.2 rpm}$$

$$\therefore \text{ Servo margin} = \frac{100}{59.6} - 1 = \underline{\underline{0.68}}$$

STRESS ANALYSIS (WINGS NO. 4, 5, 6)

The only major difference between wings No. 1, 2, & 3 and wings No. 4, 5, & 6 is the leading edge gusset design.

Gussets No. 1 & 3 are not critical by observation

Gusset No. 2 (2 gussets)

$$\text{Critical load} = F = 1162 \text{ lb ultimate (parachute configuration)}$$

$$\text{Load per inch} = \frac{1162}{2} = 581 \text{ lb/in (2 gussets)}$$

$$\text{Hoop tension} = p R = \frac{(581)}{(.063)} \quad (.0315)$$

$$= 291 \text{ lb/in (2 gussets)}$$

Allowable load = 400 lb/in (2 gussets)

$$M. S. = \frac{400}{291} - 1 = \underline{\underline{0.37}}$$

Net tension load @ load bar = 145 lb/gusset/inch

Allowable = 200 lb per gusset per inch

$$M. S. = \frac{200}{145} - 1 = \underline{\underline{0.37}}$$

Bond area of gussets to leading edge tube appear to be more than adequate to transmit the gusset loads.

WEIGHTS

Ref. Drawing 149W200

Wing

$$\text{-3 \& -4 Membrane} \quad (277.6) (.0347) \quad = \quad 9.63$$

$$A = (22)^2 \sin 35^\circ = 484(.5736) = 277.6 \text{ ft}^2$$

$$\text{Material} = \frac{5 \text{ oz. yd}^2}{\text{yd}^2 \cdot 9 \text{ ft}^2} \cdot \frac{1 \text{ lb}}{16 \text{ oz}} = .0347 \frac{\text{lb}}{\text{ft}^2} = .00024 \text{ lb/in}^2$$

$$\text{-5 Keel} \quad (20.5 \cdot 12) (22) (.0347) \quad = \quad 1.30$$

$$\text{-7 -8 Lead Edge} \quad (28 \cdot 12) (22) (.0347) (2) \quad = \quad 3.56$$

$$\text{-9 Nose Tube} \quad (23.5 \cdot 12) (1) (.0347) \quad = \quad .07$$

-11 Fwd Keel - included in -5 Calcs.

$$\text{-13 Splice} \quad (21.5 \times 2.5) (.00024) \quad = \quad .01$$

-15 Doubler	(129.2) (.00024)	= .03
-17 Doubler	(27 x 2.3 x .67) (.00024)	= .01
-19 Doubler	(21 x 1.7 x .6) (.00024) 2	= .01
-21 Doubler	(72.9) (.00024)	= .02
-23 -24 Keel Gusset	(8.5 x 264) (.00024) 2	= 1.08
-25 Shear Tie	(9.0 x 264) (.00024)	= .57
-27 Corner Doubler	(3.0 x 264) (.00024) 2	= .19
-29 Tail Cone	(11.9 x 5) (.00024) 2	= .03
-31 Doubler	(8.8 x 2) (.00024) 2	= .01
-33 Doubler	(19.0 x 2.0 x .6) (.00024)2	= .01
-35 Tail Cone Actual Weight	(2) (.12)	= .24
-37 Cover Actual Weight		= .50
-39 Mount Actual Weight		= 1.00
-41 Tube Assembly		= .06
	Tube = (.0024) 4 = .0096	
	AN818-4 Nuts (2) $\frac{.0488}{.06}$	
-43 Support Actual Weight		= .26
-45 Bracket	(5.29 x .04 x .1)	= .02
-47 Clamp Actual Weight		= .12

-49 Clamp Actual Weight		=	.12
-51 Mount Actual Weight		=	1.00
-53 Load Bar (2)	(3.2 x 1.0 x .04 x .1) 2	=	.02
-55 Doubler	(27.2 x .00024) 6	=	.04
Keel Load Bars	(1.5 x 1.0 x .04 x .1) 6	=	.04
L. E. Load Bars	(2.75 x 1.0 x .063 x .1) 8	=	.13
L. E. Gussets	(73.5 x .00024) 8	=	.14
L. E. Gusset Doublers	(22.7 x .00024) 8	=	.04
892364 Bottle Assembly		=	6.50
Standard Parts		=	.06
NAS 221-8 Screws	(.005) 7	=	.0350
NAS 1103-6 Bolt	(.006) 2	=	.0120
AN960D10 Washer	(.0005) 2	=	.0010
NAS679 A3 Nut	(.004) 2	=	$\frac{.0080}{.06}$

Wing Total Weight Not Including Glue (26.82 lb)

Calculation of Glue Weight

$$\text{Wt. of Glue} = \frac{.5 \text{ oz}}{\text{ft}^2} = .000217 \frac{\text{lb}}{\text{lb}^2} \quad (\text{with coat of glue on each surface joined})$$

Membrane

Forward material splice 176 (.000217) = .04

$$A = 2 \times 88 = 176$$

Splices & Doublers - Forward

-13 Splice 47.5 (.000217) = .01

$$A = 2.5 \times 19 = 47.5$$

-15 Doubler 129.2 (.000217) = .03

$$A = 129.2$$

-17 Doubler 41.5 (.000217) = .01

$$A = 27 \times 2.3 \times .67 = 41.5$$

-19 Doubler 21.4 (.000217) = .005

$$A = 21 \times 1.7 \times .6 = 21.4$$

-21 Doubler 72.9 (.000217) = .02

$$A = 72.9$$

Keel Gussets

Keel Lap 1056 (.000217) = .23

$$A = 2 \times 2 \times 264 = 1056$$

Membrane Lap 792 (.000217) = .17

$$A = 1.5 \times 2 \times 264 = 792$$

Shear Tie

Membrane Lap 792 (.000217) = .17

$$A = 1.5 \times 2 \times 264 = 792$$

Corner Doubler

Gusset Lap 792 (.000217) = .17

$$A = 1.5 \times 2 \times 264 = 792$$

Shear Tie Lap 792 (.000217) = .17

$$A = 1.5 \times 2 \times 264 = 792$$

Tail Cone

L. E. Lap 76 (.000217) = .02

$$A = 2 \times 2 \times 19 = 76$$

Aft Doublers

-31 Doubler 35.2 (.000217) = .008

$$A = 2 \times 2 \times 8.8 = 35.2$$

-33 Doubler 45.6 (.000217) = .01

$$A = 19.0 \times 2.0 \times .6 \times 2 = 45.6$$

Bottle Cover (-37)

Keel lap 38 (.000217) = .008

$$A = 2 \times 19 = 38$$

-43 Support

Keel Lap 38 (.000217) = .008

$$A = 2 \times 19 = 38$$

-55 Doubler

Gusset Lap 165.6 (.000217) = .04

$$A = 27.2 \times 6 = 165.6$$

L. E. Gussets

L. E. Lap 168 (.000217) = .04

$$A = 2 \times 14 \times 6 = 168$$

L. E. Gusset Doublers Lap 181.6 (.000217) = .04

$$A = 8 \times 22.7 = 181.6$$

Total Glue Weight 3 lb

<u>Weight and Balance</u>	W	X	WX
-3 and -4 Membrane	9.63	168.0	1617.84
-5 Keel	1.30	132.0	171.60
-7 -8 Leading Edge	3.56	120.0	427.20
-9 Nose Tube	.07	7.3	.51
-13 Splice	.01	15.9	.16
-15 Doubler	.03	7.3	.22
-17 Doubler	.01	8.5	.08
-19 Doubler	.01	7.3	.07
-21 Doubler	.02	5.5	.11
-23 & -24 Keel Gusset	1.08	132.0	142.56
-25 Shear Tie	.57	132.0	75.24
-27 Corner Doubler	.19	132.0	25.08
-29 Tail Cone	.03	237.0	7.11
-31 Doubler	.01	238.4	2.38

	W	X	WX
-33 Doubler	.01	234.7	2.35
-35 Tail Cone	.24	239.3	57.43
-37 Cover	.50	265.5	132.75
-39 Mount	1.00	260.5	260.50
-41 Tube Assembly	.06	263.0	13.15
-43 Support	.26	262.0	42.12
-45 Bracket	.02	264.7	5.29
-47 Clamp	.12	260.5	31.26
-49 Clamp	.12	153.5	18.42
-51 Mount	1.00	153.5	153.50
-53 Load Bar	.02	1.9	.04
-55 Doubler	.04	152.0	6.08
Keel Load Bars	.04	152.0	6.08
L. E. Load Bars	.13	121.4	15.78
L. E. Gussets	.14	121.4	17.00
L. E. Gusset Doublers	.04	121.4	4.86
892364 Bottle Assy.	6.50	257.3	1672.45
Std. Parts	.06	262.0	15.72
Memb. Splice Glue	.04	60.0	2.40
Memb. Splice Glue	.07	105.0	7.35
Memb. Splice Glue	.10	152.0	15.20
Memb. Splice Glue	.13	203.0	26.39
Memb. T. E. Lap Glue	.15	241.0	36.15
Memb. L. E. Lap Glue	1.03	119.6	123.19
Keel Tube Glue	.09	132.0	11.88
L. E. Tube Glue	.23	120.0	27.60

	W	X	WX
Nose Tube Glue	.005	4.5	.02
-13 Splice Glue	.01	15.9	.16
-15 Doubler Glue	.03	7.3	.22
-17 Doubler Glue	.01	8.5	.08
-19 Doubler Glue	.005	7.3	.04
-21 Doubler Glue	.02	5.5	.11
Keel Gusset to Keel Glue	.23	132.0	30.36
Keel Gusset to Memb. Glue	.17	132.0	22.44
Shear Tie to Memb. Glue	.17	132.0	22.44
Corner Dblr. To Gusset Glue	.17	132.0	22.44
Corner Dblr. to Shear Tie Glue	.17	132.0	22.44
L. E. Tail Cone Glue	.02	238.8	4.68
-31 Dblr. Glue	.008	238.4	1.91
-33 Dblr. Glue	.01	234.7	2.35
-37 Glue	.008	263.0	2.10
-43 Glue	.008	262.0	2.10
-55 Glue	.04	152.0	6.08
L. E. Gussets Glue	.08	121.4	9.71
TOTAL WING WEIGHT	(29.82)	(178.56 in)	(5324.78)
		(14.88 ft)	

Calculation of Dummy C. G.

Actual weight of dummy = 228.1 lb

The dummy was placed on two platform scales, one near the shoulders and one at the feet. It rested on a narrow board at each end and was level. The weights measured by each scale are shown in sketch below:

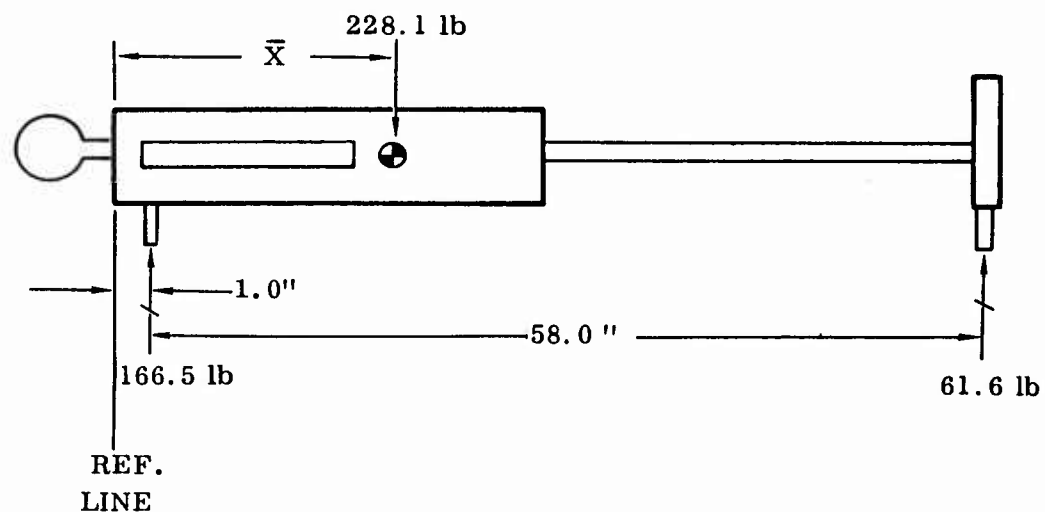

$$\bar{X} = \frac{(1) (166.5) + (59) (61.6)}{228.1} = \frac{166.5 + 3634.4}{228.1}$$

$$\bar{X} = \frac{3800.9}{228.1} = \underline{\underline{16.66}} \text{ inches}$$

Missing items when weighed:

Accelerometer	Suit
Dry Cell Battery - 6V and Clamp	Padding
Straps	Chute Supports
Coax Cables	Helmet
Antenna	
Screws and Bolts	

FABRICATION

Fabrication commenced concurrently on the instrumented dummy and the wing assembly. The Ryan Experimental Shop fabricated both assemblies, and the Engineering Shop performed the installation of the instrumentation equipment.

Instrumented Dummy

Figure 26 depicts the upper chest portion of the dummy, which houses the pitch and roll control servo assemblies as well as the flare release mechanism.

Figure 27 shows the lower portion of the torso, which is to house the primary and secondary power supplies, airborne oscillograph, receiver/decoder, and required wiring. Note the rubberized knee joint for energy dissipation during landing.

Figure 28 shows the attachment of the upper chest control cavity to the lower torso portion, or instrumentation section. Note the installation of primary power supply battery box and the CEC-airborne oscillograph.

Figure 29 shows the completely hardware fabricated dummy less required wiring and instrumentation. Note the installation of the flare release solenoid in the lower portion of the control cavity.

Wing Assembly

Figure 30 reflects the template layout of the membrane to keel section. The coated fabric is marked by utilizing various shop aid templates, is cut with



Figure 26 Upper Chest Cavity of Dummy

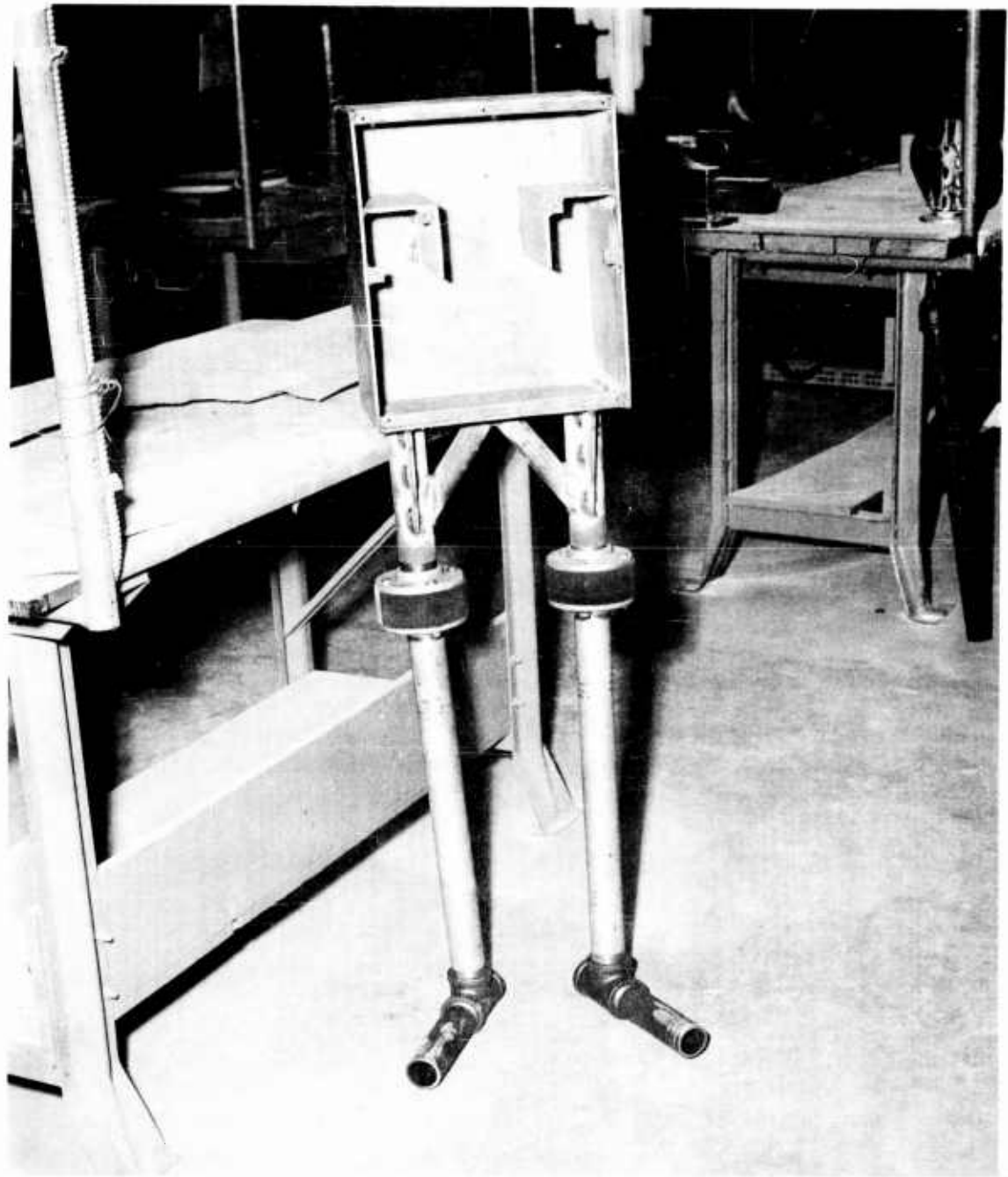

Figure 27 Lower Torso of Dummy

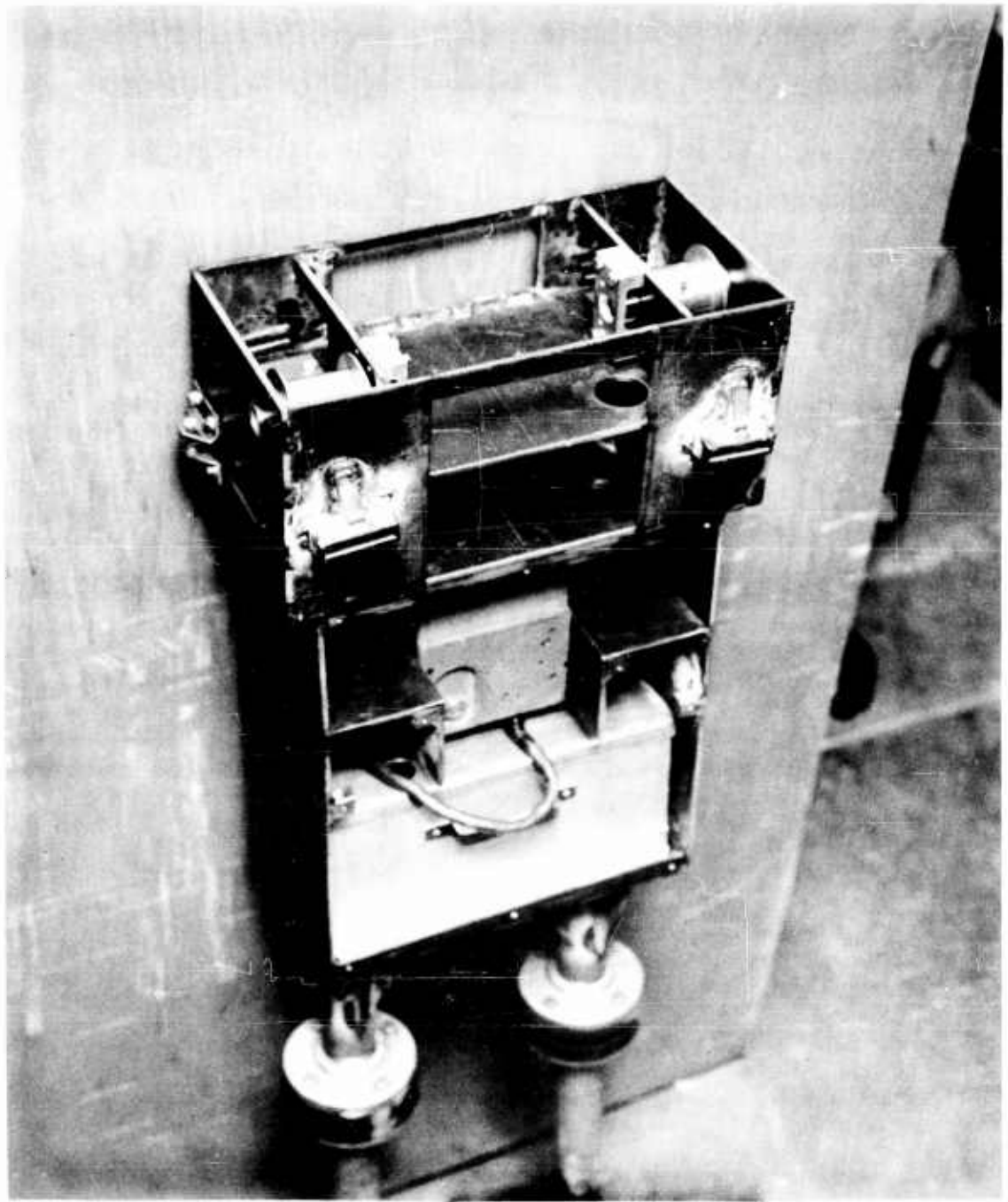

Figure 28 Installation of Upper to Lower Cavities



Figure 29 Complete Hardware Fabricated Dummy

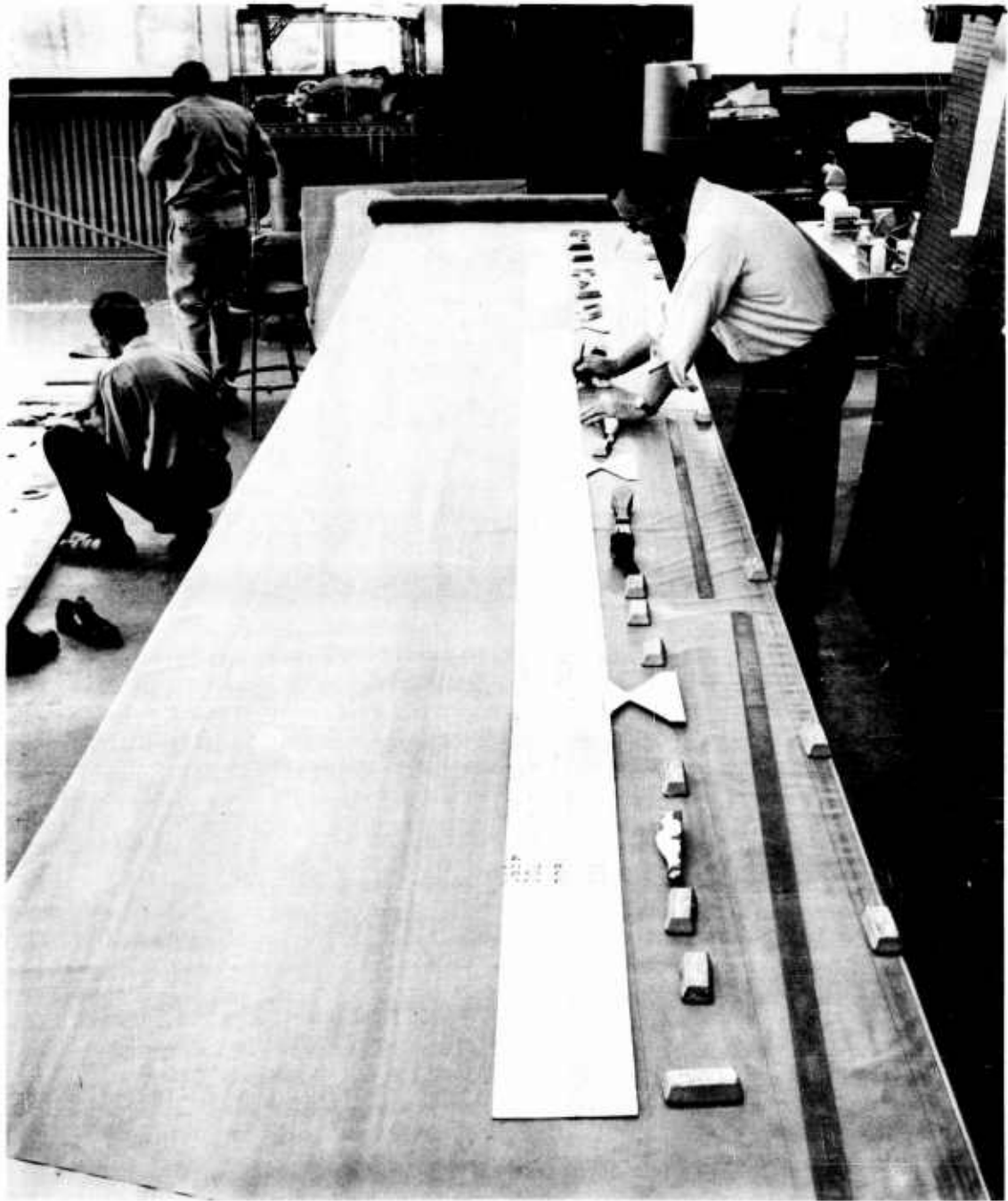

Figure 30 Template Fabric Marking

scissors, is cleaned with MEK (methylethylkeytone), and is bonded together with 3M EC-2134/EC-2135 adhesive.

Figure 31 shows a close-up of the leading edges, the keel, and the apex section prior to mating. Note the shop aid fixture in the left-hand leading edge.

Figure 32 is an over-all view of the leading edges, the keel, and the apex section prior to mating.

Figure 33 shows a completed membrane assembly being prepared for the installation of the tube sections, i. e., leading edges, keel, and apex section. Note in the background the weighted rolling tool used when bonding joints.

Figure 34 shows a completed wing with shroud lines attached and pneumatic assembly installed. Note the fairing tail cone on the after end of the keel.

FLIGHT TEST

Wing Packing Procedure

System reliability during the deployment sequence is dependent on the method of packing the wing and stowing the suspension lines. The packing method used must be systematic and must be such that the packing procedure is repeatable.

The photographs shown in Figures 35 and 43 depict a typical packing procedure. This was the original packing procedure used. During the course of the test program, modifications to this procedure were made. These changes were primarily methods of line stowage and are listed in Table 1.

Figure 34 shows the wing stretched on the floor with the inflatable structural members facing upward (underside). All the air is removed from the members to facilitate packing. All suspension lines attached to the leading edges are pulled to the side, away from the wing. The lines attached to the keel are pulled either forward or aft along the keel.

Figures 35 and 36 show the pleating operation. Pleating starts adjacent to the keel. All pleats are approximately 8 to 10 inches wide. Figure 37 shows the wing pleated. The next operation is to fold the wing in half, bringing the apex even with the air bottle. The apex is then folded back a distance of 2 feet (Figure 38).

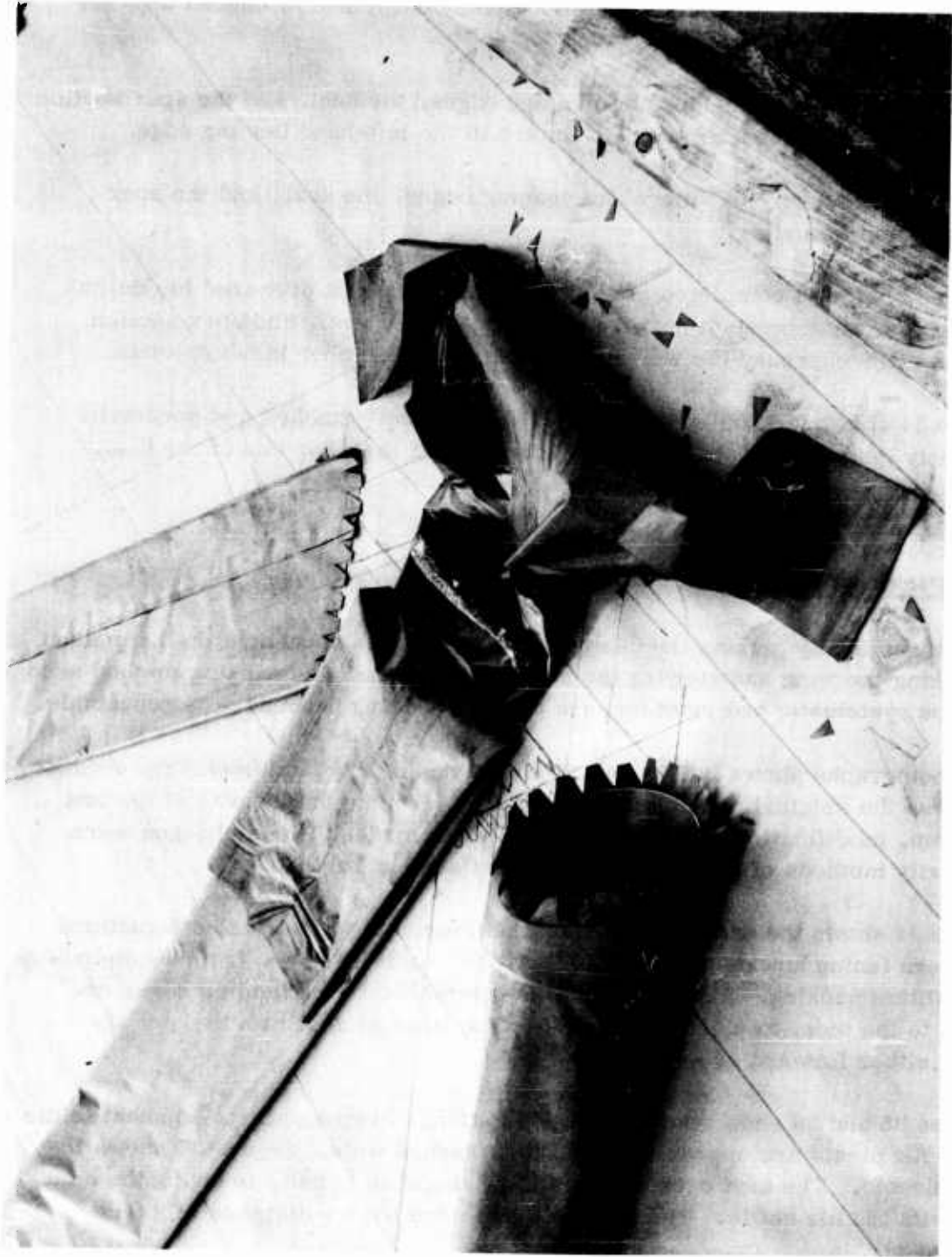

Figure 31 Leading Edge, Keel, Apex Section (Close-Up)

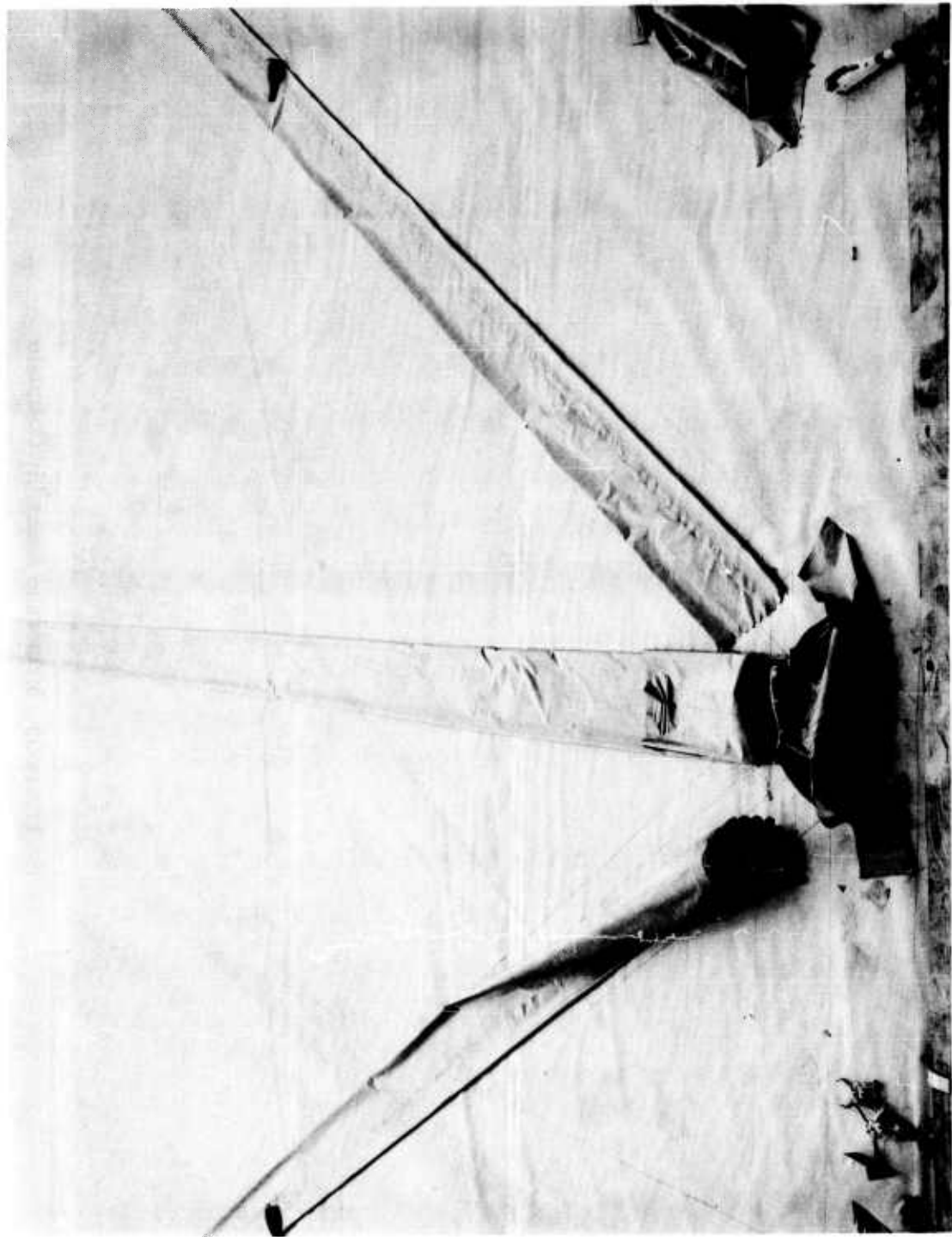

Figure 32 Leading Edge, Keel, Apex Section (Over-All)



Figure 33 Membrane Assembly Complete

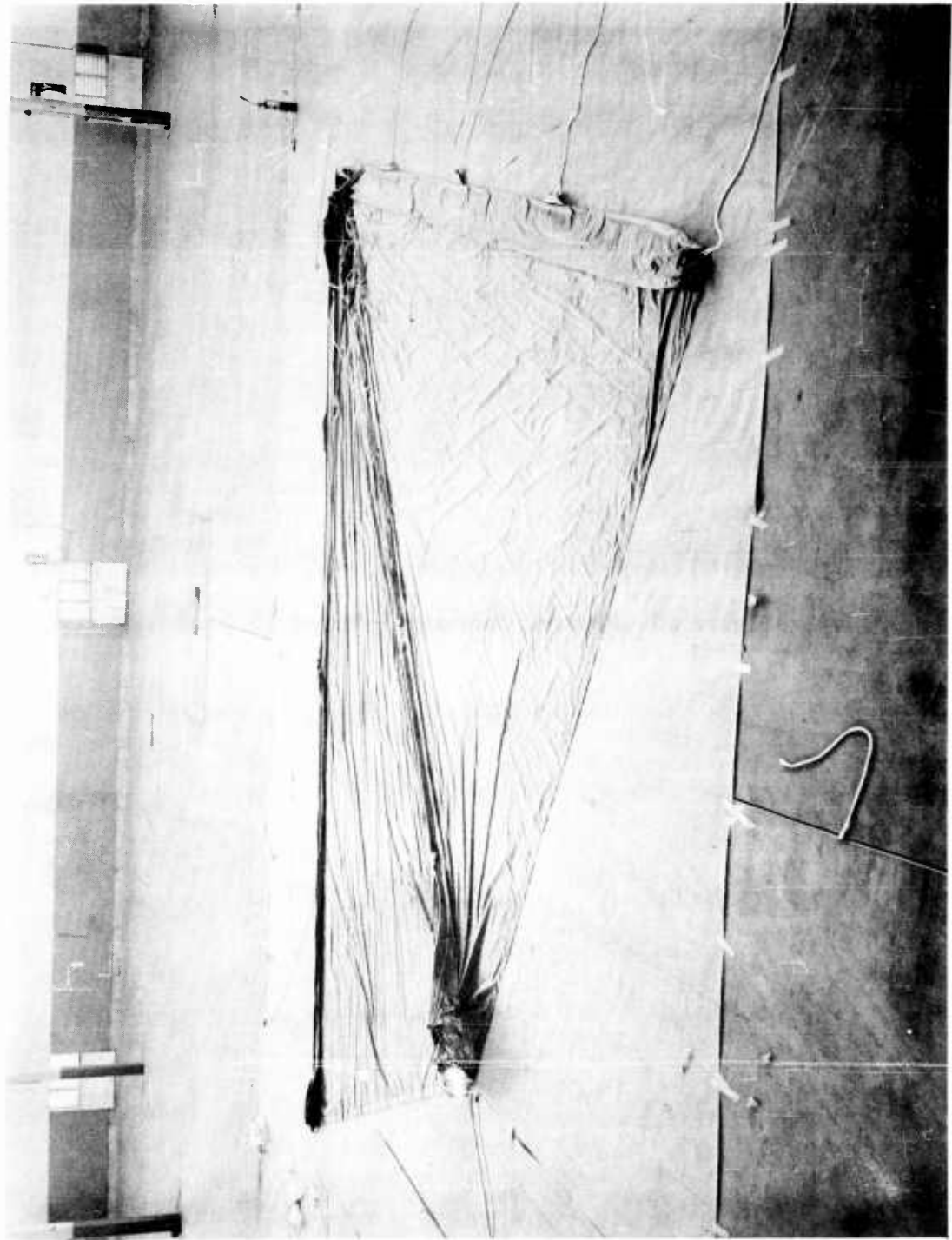

Figure 34 Wing Assembly Complete

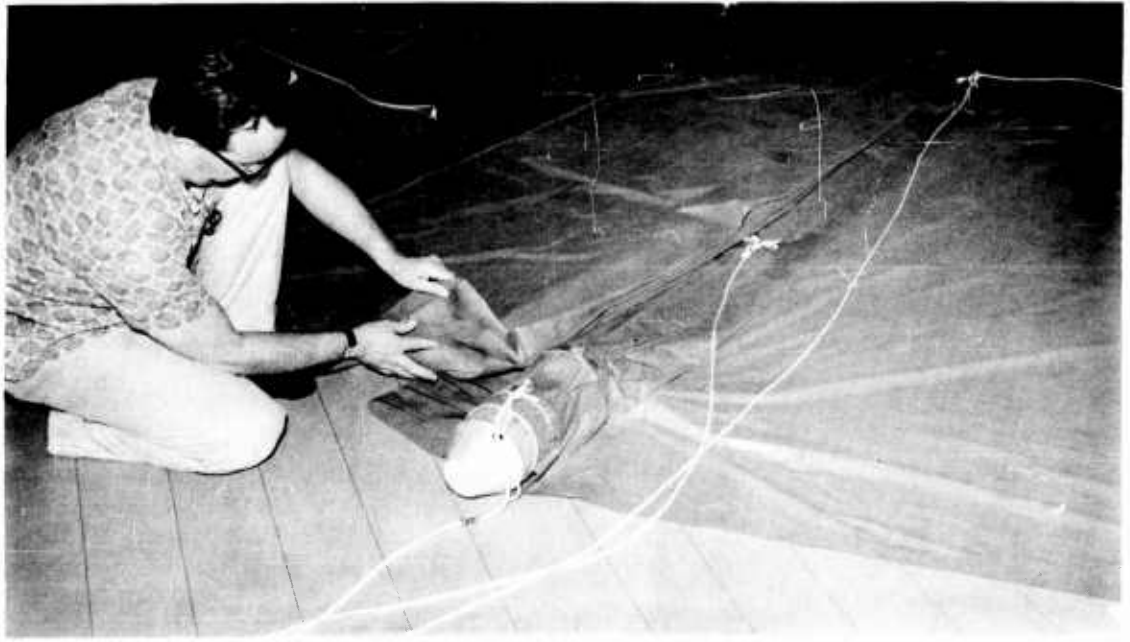

Figure 35 Pleating Operation - Initial

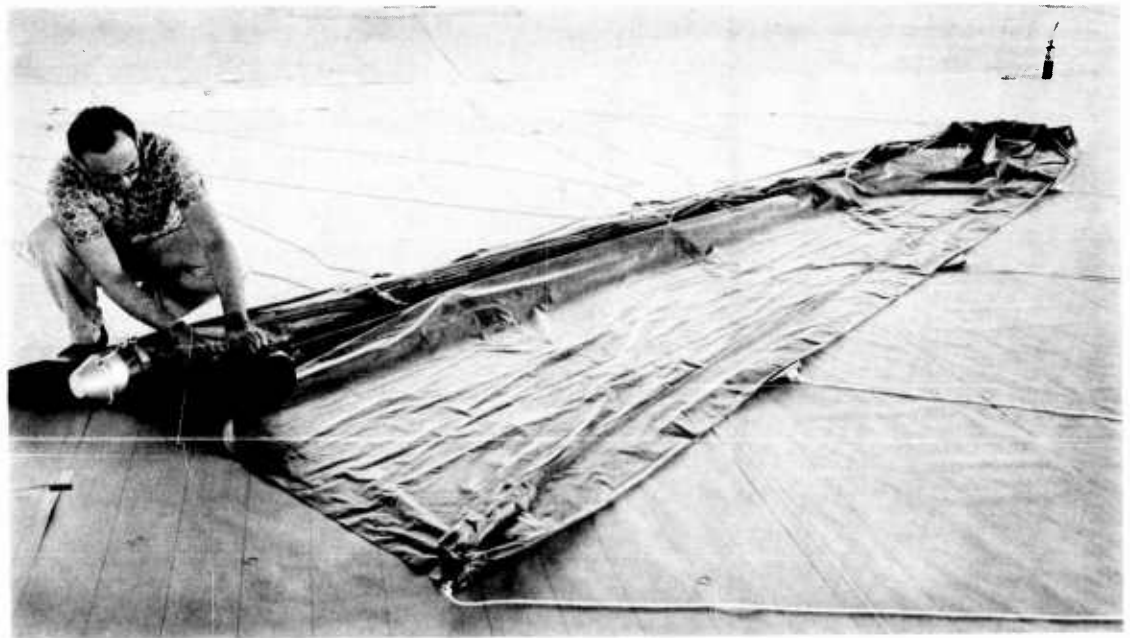

Figure 36 Pleating Operation

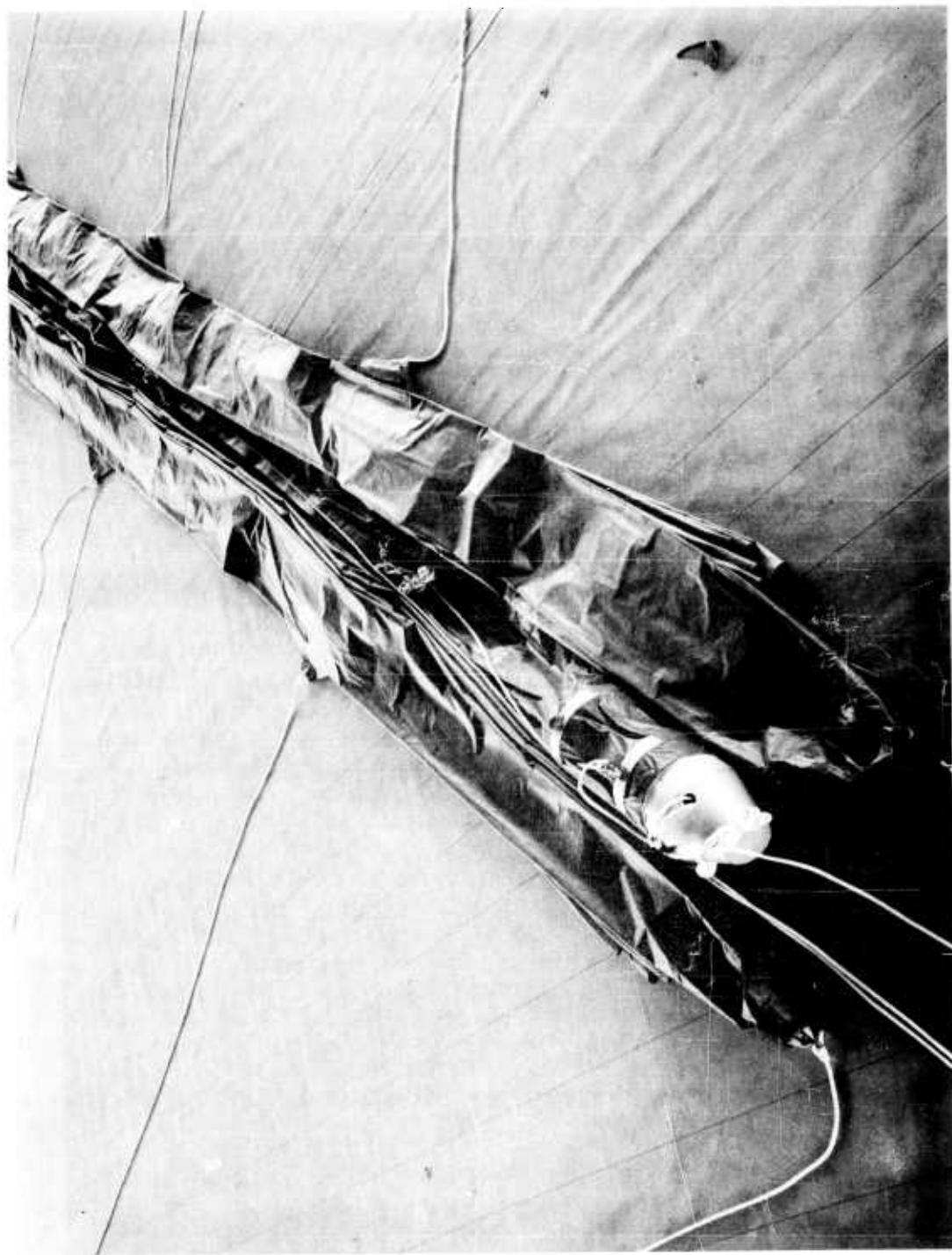

Figure 37 Pleated Wing

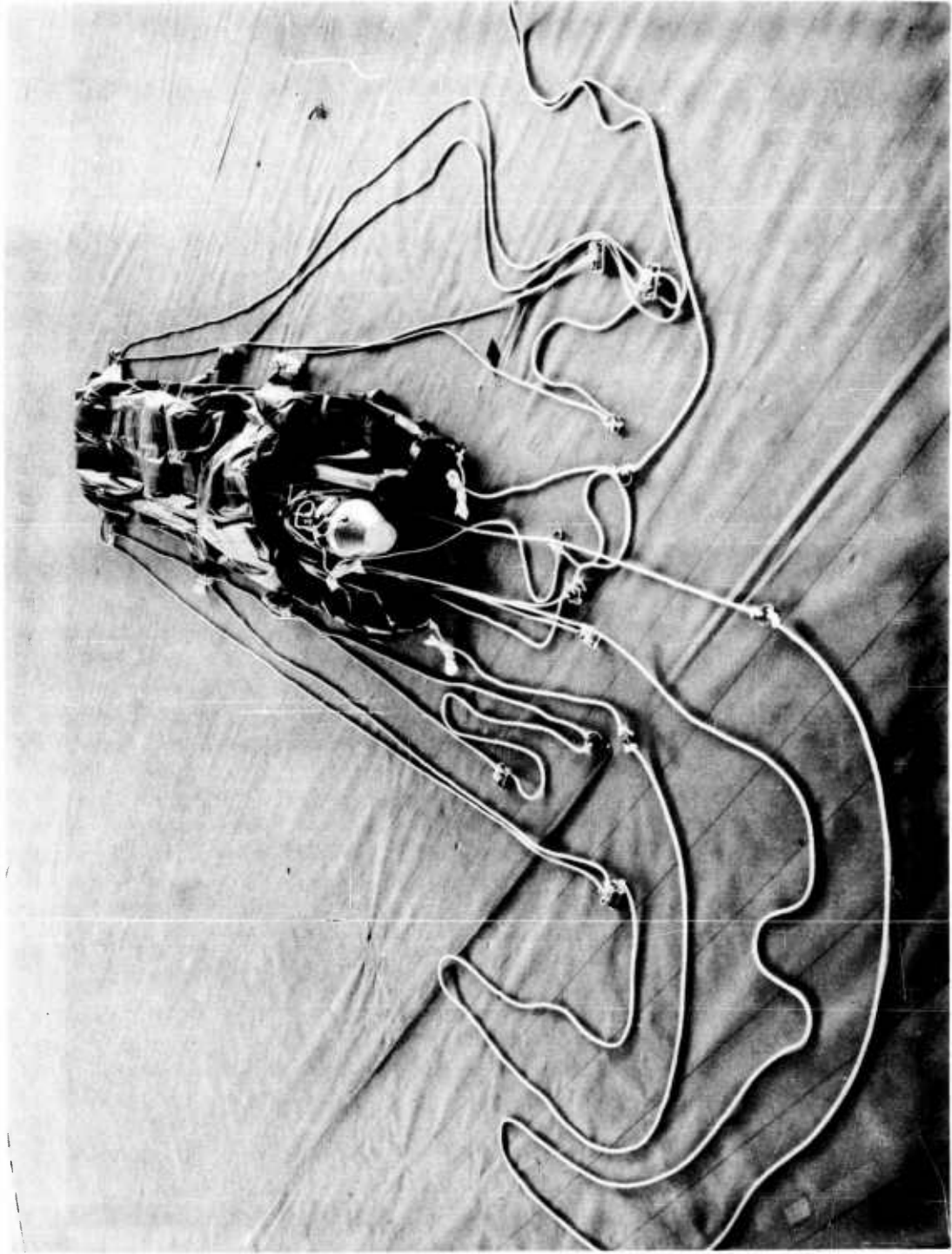

Figure 38 Wing - Pleated and Folded

Figure 39 shows the riser strap assembly attached to the suspension lines. All excess suspension lines are stowed on the wing at the gusset area and are held in place with rubber bands using standard parachute line stowage techniques. The six suspension lines used for the parachute configuration are foreshortened, and the excess line is stowed in the zippered pockets on the riser strap assembly. These pockets are visible in Figures 40 and 41.

Figure 40 shows the wing stowed in the nylon sleeve. The sleeve is 9 feet long with an 8-foot static line attached. Figure 41 shows the wing just prior to being put into the back pack container. This container is patterned after a standard T-10 personnel parachute container. The wing is accordion folded into the back pack container as shown in Figure 42. Figure 43 shows the final pack ready for use. The size of the completed pack is 17 by 28 by 8 inches, with a total weight of 35 pounds.

Test Procedures

Test procedures for this program followed closely those established for parachute testing. All drop tests were made from either the U-1A or the L-20 type aircraft. All drops were made at a predetermined altitude, heading, and air-speed.

For Drop tests using the instrumented dummy, the mobile ground control station was located at the periphery of the drop zone near the release point. Prior to launch, a ground-to-air remote system check was made to insure system operation. The paraglider was launched on a countdown from the launch aircraft commander.

System operation during the deployment sequence and glide mode is depicted in the operational sequence drawing, Figure 44. The back pack is opened by a static line and the sleeve is deployed. The static line, which is attached to the sleeve, withdraws the wing after breaking open the back pack. Upon complete suspension-line stretch, the sleeve is pulled off the wing. Initially, the wing is deployed in a configuration resembling a parachute. Suspension lines are reefed to appropriate lengths, forming the wing into the parachute shape. The wing is held in the parachute shape to decelerate the system. The tube inflation operation is started while the wing is still in the parachute mode, this system also being activated by a separate time-delay reefing cutter. The reefed suspension lines are then released by time-delayed reefing cutters, which are activated by sleeve removal.

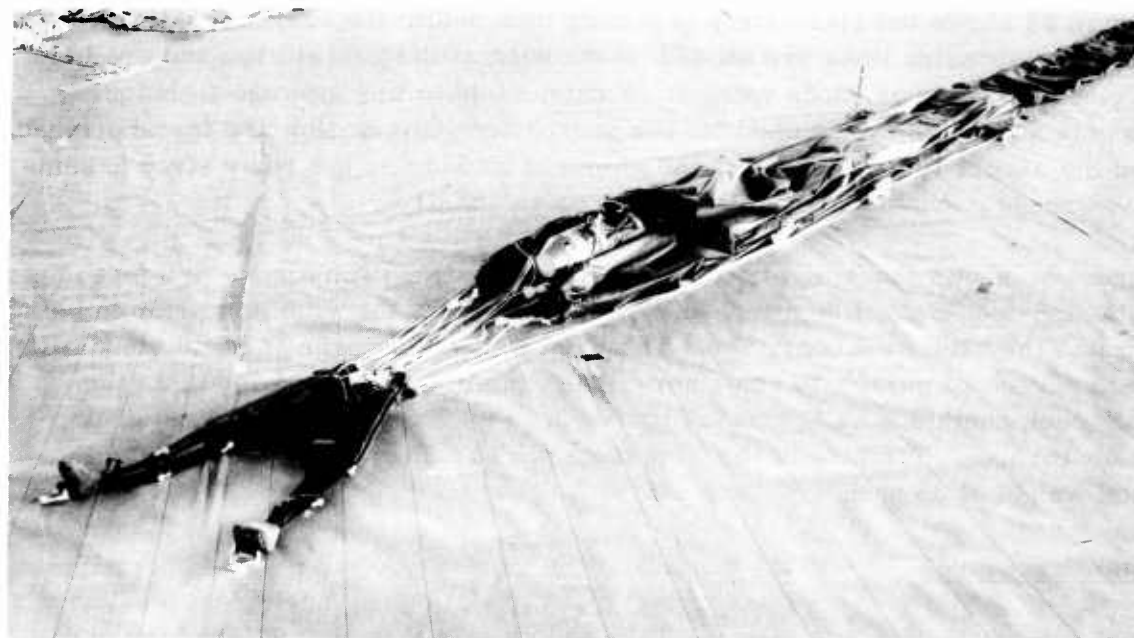

Figure 39 Wing with Riser Strap Assembly Attached

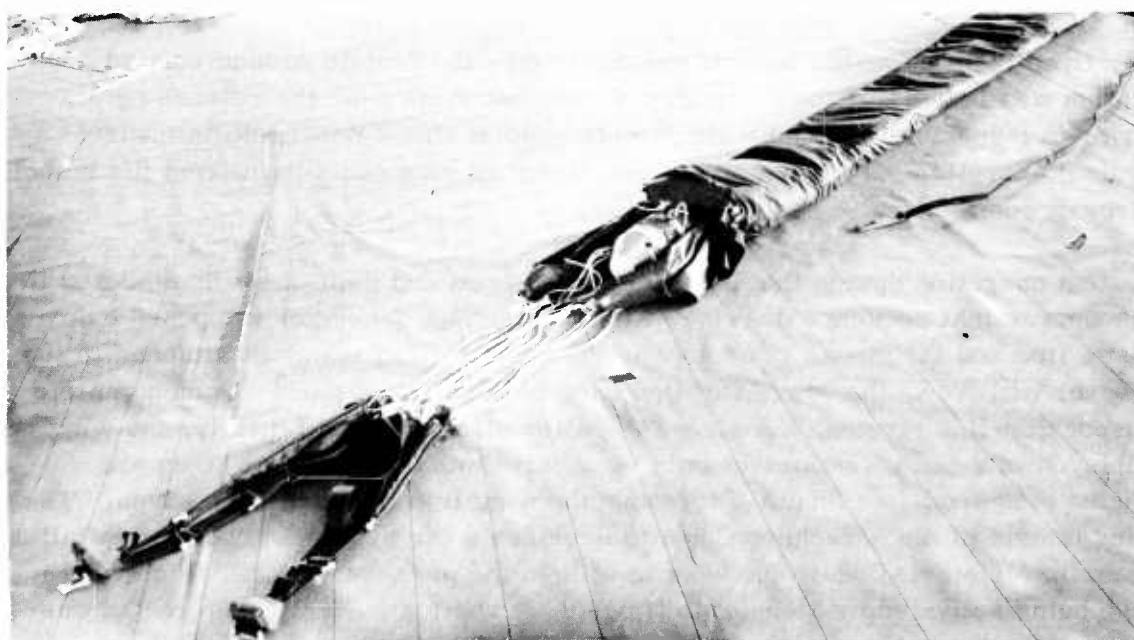

Figure 40 Wing Stowed in Nylon Sleeve



Figure 41 Wing Prior to Stowage in Back Pack Container



Figure 42 Wing Folded in Back Pack Container



Figure 43 Final Wing Pack

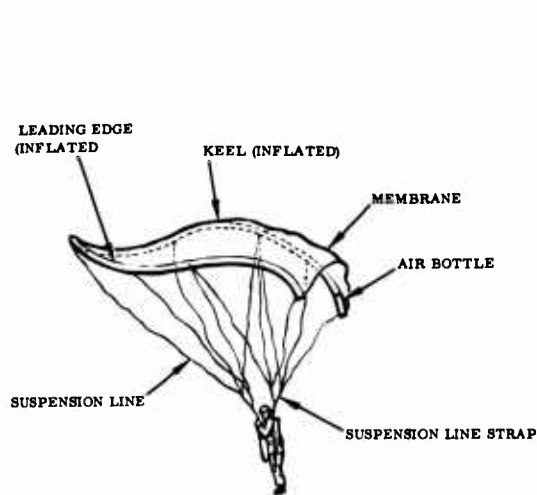

Figure 7
 PARA-WING IN TRANSITION
 FROM PARACHUTE TO WING

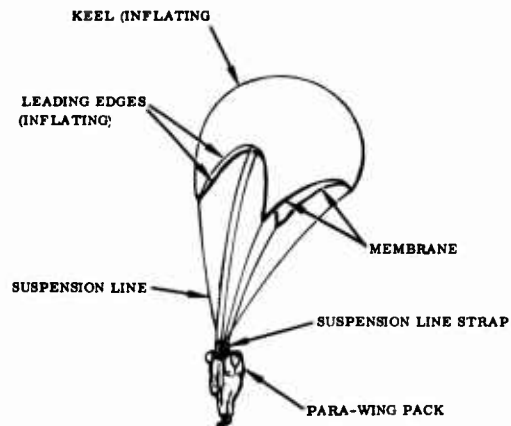

Figure 6
 PARA-WING OPENS
 INTO A PARACHUTE

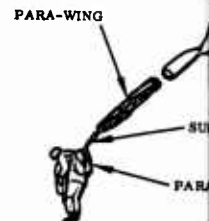

Figure 5
 SLEEVE LEAVING
 PARA-WING

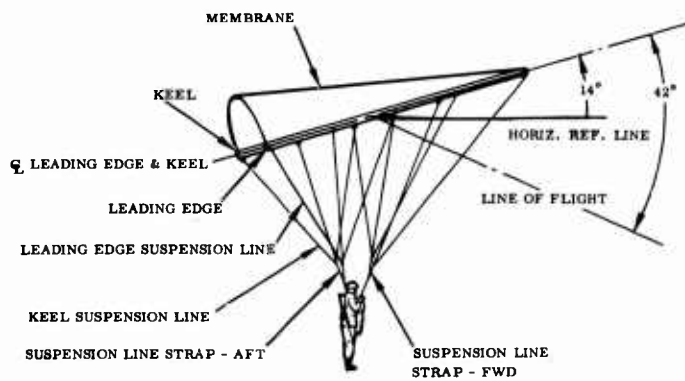

Figure 8
 WING FULLY INFLATED AND
 IN PREDETERMINED GLIDE
 PATH

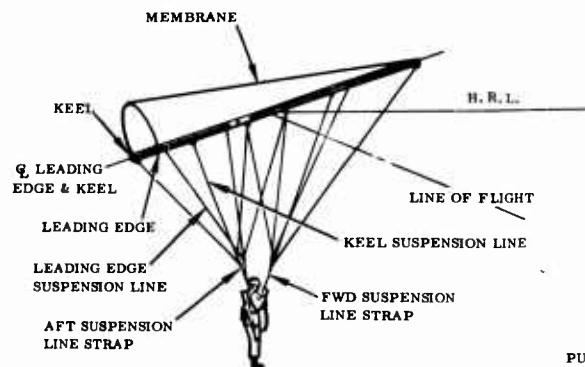

Figure 9
 PARA-WING CONTINUING
 DESCENT

PULLS DOWN ON AFT
 EDGES SUSPENSION L

GROUND LI

1

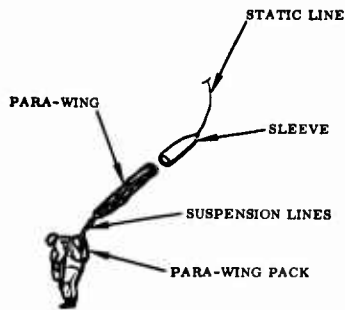

Figure 5
SLEEVE LEAVING
PARA-WING

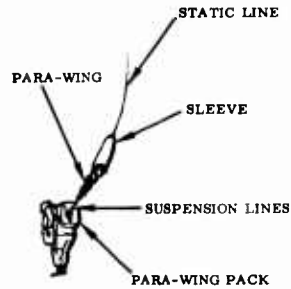

Figure 4
PARA-GLIDER & SLEEVE
LEAVING PACK

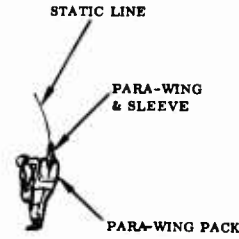

Figure 3
PARA-GLIDER & SLEEVE
STARTING OUT OF PACK

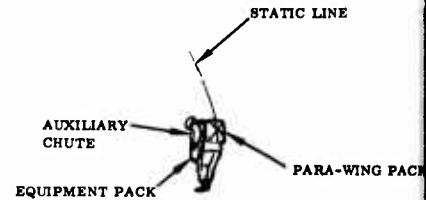

Figure 2
CLEAR OF SHIP AND
FLEXIBLE WING PACK
UNOPENED

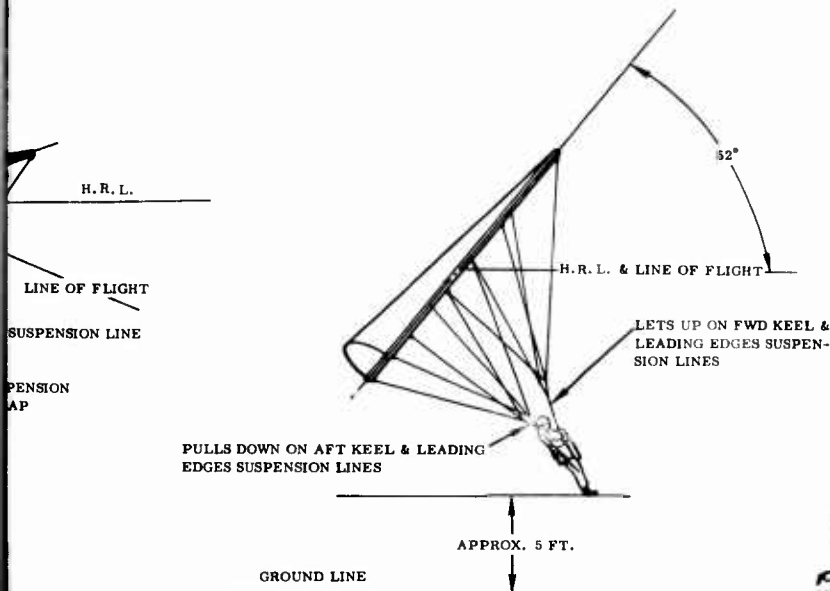

Figure 10
PARA-WING STARTING FLARE
UP MANEUVER PRIOR TO
LANDING

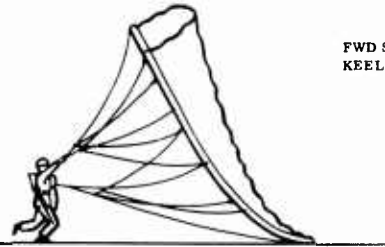

Figure 11
LANDING OF PARA-WING
AND PARA-TROOPER

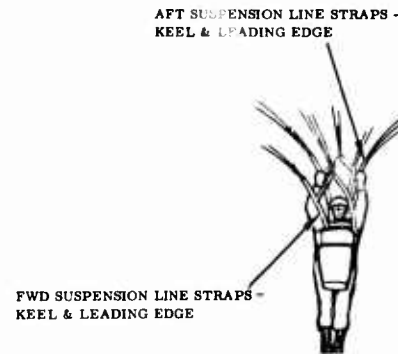

Figure 12 (NO SCALE)
SHOWING METHOD OF OBTAINING
ROLL CONTROL BY PULLING
DOWN ON THE AFT SUSPENSION
LINES OF ONE LEADING EDGE ONLY

Figure 44 Operational Sequence D

STATIC LINE
 SLEEVE
 SUSPENSION LINES
 PARA-WING PACK
 SLEEVE

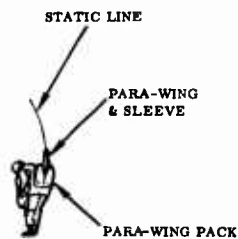

Figure 3
 PARA-GLIDER & SLEEVE
 STARTING OUT OF PACK

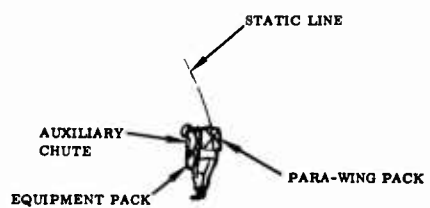

Figure 2
 CLEAR OF SHIP AND
 FLEXIBLE WING PACK
 UNOPENED

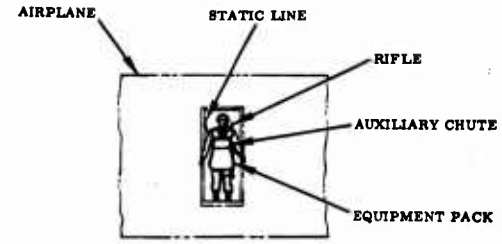

Figure 1
 READY TO JUMP

FWD KEEL &
 SUSPEN-

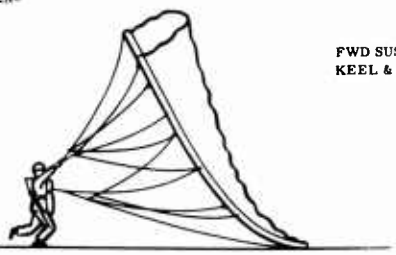

Figure 11
 LANDING OF PARA-WING
 AND PARA-TROOPER

AFT SUSPENSION LINE STRAPS -
 KEEL & LEADING EDGE



Figure 12 (NO SCALE)
 SHOWING METHOD OF OBTAINING
 ROLL CONTROL BY PULLING
 DOWN ON THE AFT SUSPENSION
 LINES OF ONE LEADING EDGE ONLY

FWD SUSPENSION LINE STRAPS -
 KEEL & LEADING EDGE

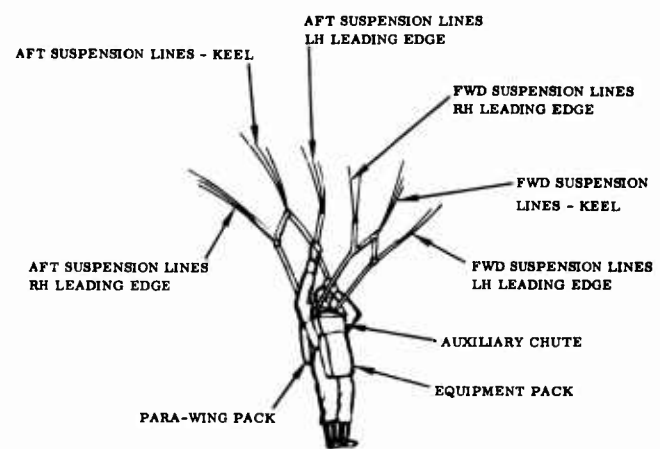

Figure 13 (NO SCALE)
 SHOWING METHOD OF OBTAINING
 PITCH CONTROL BY PULLING DOWN
 ON THE AFT SUSPENSION LINES OF
 BOTH LEADING EDGES & THE KEEL.
 THE ABOVE METHOD IS ALSO USED
 FOR THE FLARE-UP MANEUVER.

Figure 44 Operational Sequence Drawing

3

Each test drop during this program followed the previously outlined test procedure. Variations in test configuration involved changes in line stowage methods, line lengths, reefing cutter time delay sequencing, and build-up of dummy gross weight to 265 pounds.

During all drops, motion picture coverage was obtained in various combinations of ground to air, air to air, and in a few cases air to ground.

As soon as sufficient progress had been made in the test program to warrant the use of the instrumented dummy, data acquisition was begun. Loads and acceleration data were obtained from the dummy and cinetheodolite range data were added as a means of acquiring flight-path information, such as rate of descent and impact velocities.

Test Results

Eighty-six airdrops of the IDG wing and five helicopter tow operations were conducted at the U. S. Army Yuma Test Station during the period from 25 July to 21 November 1962.

The changes incorporated prior to each of the flight test operations are presented chronologically in Table 1. Table 2 presents a chronological listing of wing/dummy configuration and launch conditions for each of the flight test operations. The original paraglider line lengths are presented in Table 3.

The initial phases of the test program consisted of air drops of a 13-gusset wing rigged to a 38° angle of attack. See Figure 3 for wing line nomenclature for both the 13- and the 16-gusset wing. During this early testing, a 105-pound rope dummy and a 240-pound molded rubber torso dummy were used to simulate a paratrooper.

Fifteen airdrops and two helicopter tow operations were conducted with the wing in the 38° angle of attack configuration. Parachute formation was satisfactory during eleven of these fifteen drops; however, successful transition into the glider mode was not attained on any of this series of drops. Suspension line failures, line twist, and membrane and tube structural failures all contributed to the difficulties preventing successful wing transition.

The wing was then rigged to a 30° angle of attack, and the No. 6 and No. 8 gusset suspension lines were replaced with double 1000 pound lines, or combinations of 1000- and 500-pound suspension lines, in an attempt to eliminate aft leading edge line failure. Of the eight air drops made in this configuration, there were two successful transitions to the glider mode, using the 105-pound dummy from launch altitudes of 500 and 1000 feet respectively. Air bottle actuation failure occurred during four of these drops, thus precluding transition to the glider mode.

Tube buckling problems encountered during this phase of the test program were subsequently minimized by using a heat exchanger in conjunction with the air compressor during the charging operation of the 125-cubic-inch air bottle. The use of the heat exchanger permitted the attainment of a 4000-psig air charge on a single charge delay basis as compared to the original nominal value of 3300 psig.

Testing was then continued using a 167-pound dummy for eight additional drops, six of which were at altitudes below 700 feet. Transition to the glider mode was achieved during five of the drops, with line pickup occurring on the remaining three. Line entanglement was encountered during one additional drop from an altitude of 500 feet with the wing rigged to the parachute configuration only. During each case, after formation of the wing configuration and attainment of steady-state glide mode, varying degrees of wing trailing-edge flutter were observed.

Additional low-altitude testing, at launch altitudes from 500 to 700 feet, was conducted using the 240-pound torso dummy. Thirteen drops were made at low altitude to permit close-in ground-to-air motion picture film coverage of the launch and deployment characteristics. Two successful glider transitions were made, five cases of membrane or suspension line failure occurred, and four cases of line pickup and two cases of line entanglement were encountered.

Launch altitude was then increased to altitudes of 1000 to 2000 feet, a restrictor was added to the air supply line to slow down the air injection rate to the tubes, and drops were resumed using a 200-pound dummy. Two unsuccessful attempts (without the restrictor) to deploy directly into the glider were made. Six launches were made using the air bottle line restrictor, and a glider was formed on only one of these attempts; line pickup and line entanglement occurred on the remaining five drops. Two drops were made without the line restrictor, one resulting in line pickup and the other in an air bottle malfunction.

The No. 1 parachute line was then lengthened from the original length of 6 feet to 9 feet and the No. 3 and No. 11 parachute line lengths were shortened from 11 feet 6 inches to 10 feet 6 inches in an attempt to eliminate line pickup during the transition from the parachute to the wing. The over-all glider line lengths remained unchanged from the original values. Of the five drops made in this configuration, three yielded satisfactory glider formation, one case of line pickup was encountered, and the air bottle failed to inflate the tubes on the remaining drop.

Nine air drops were made using the 215-pound instrumented dummy, three of which made successful transitions to the glider mode. All of the satisfactory glider formations occurred with the modifications incorporated in the No. 1, No. 3, and No. 11 parachute lines as noted previously. Membrane failures, line fouling, and line failure accounted for the six failures of the IDG to make a successful transition into the glider.

The instrumented dummy was then ballasted up to a gross weight of 265 pounds. The first four drops were unsuccessful due to line failure and line pickup. The following changes were incorporated during the last eleven drops of the instrumented dummy at this high gross weight:

- a. The wing keel line lengths were shortened to the following dimensions:

No. 14	14 feet 5.2 inches
No. 15	14 feet 9.5 inches
No. 16	13 feet 7.5 inches
No. 16a	13 feet 2.0 inches (16-gusset wing only)
No. 7	13 feet 5.0 inches

In addition to the shortened keel lines, a modified method of line stowage was used during the last ten drops of the 265-pound instrumented dummy as follows:

- a. Loosely stow a length of No. 2 (No. 12) line equal to the distance from gusset No. 2 (No. 12) to gusset No. 13 at the No. 2 (No. 12) gusset.
- b. Stow the remaining length of line No. 2 (No. 12) in a bundle at the membrane near the No. 13 gusset after the wing is pleated.

This modification was made in an attempt to alleviate the line pickup tendency. Six of the last seven drops, all of which incorporated the aforementioned modifications, yielded successful transitions to the glider mode at the maximum design dummy weight of 265 pounds.

Quantitative test results presented in this section were obtained during the thirteen drops using the instrumented dummy. Oscillograph records were obtained during these thirteen drops, and cinetheodolite data were also obtained concurrently during four of these drops.

A chronological series of individual flight reports for these thirteen drops, wherein quantitative data were obtained, is presented in the Appendix. Significant system changes may be found in Table 1 of this report.

Shock-load data were obtained from both a vertical and a horizontal accelerometer mounted on the body of the instrumented dummy, Figure 4, and from strain-gage load links located in each of the four parachute riser straps.

Opening shock acceleration loads were obtained during five dummy drops at a gross weight of 215 pounds and during eight drops at 265 pounds. These data are presented in Table 4.

Landing shock acceleration loads were obtained during one landing at a gross weight of 215 pounds and during four landings at 265 pounds. Landing-load data are presented in Table 5.

Opening shock strain-gage data were obtained during four drops at a gross weight of 215 pounds and during six drops at 265 pounds. Strain-gage data for each individual riser strap are presented in Table 6.

Average values for opening shock loads, landing shock loads, and riser opening shock loads for both test gross weights, 215 and 265 pounds, are presented in Tables 7, 8, and 9 respectively.

Evaluation

The results of this test program are discussed and evaluated under the following four major categories:

- a. Packing and deployment
- b. Opening loads and accelerations
- c. Glide and control
- d. Landing loads and velocities

The standard method of reducing pulse-type data was used in evaluating oscillograph records. Figure 45 defines the terms and the analysis method.

Packing and Deployment

During the course of the test program, a continuing evolution of the packing and deployment sequencing took place. The final configuration resulted in a procedure which produced six successful deployments out of seven attempts. This final configuration proved the structural integrity of the IDG system at the maximum design gross weight of 265 pounds, at altitudes up to 4000 feet and at a launch speed of 65 knots indicated airspeed.

Opening Loads and Accelerations

The average normal acceleration experienced during deployment for the maximum design weight of 265 pounds is 5.5 g. The corresponding horizontal acceleration is 1.7 g. The accelerometers were mounted on the dummy and measured accelerations in the vertical and horizontal planes of the dummy. Lateral accelerations were not measured. No attempt was made to determine dummy attitude during deployment or to correlate dummy attitude with deployment loads and forces. The average duration for the normal and horizontal g-loads is 0.67 and 0.17 seconds respectively. A time history of the opening accelerations for a typical flight (91) is shown in Figure 46. Time history traces of the opening shock loads, as measured by each of the four strain-gage riser load links, are shown in Figure 47 for flight 91. The risers do not load up evenly during the deployment sequence; therefore, to obtain a representative picture of the loads experienced by the dummy, the four riser loadings must be summed and plotted on a common time scale. This summation has been

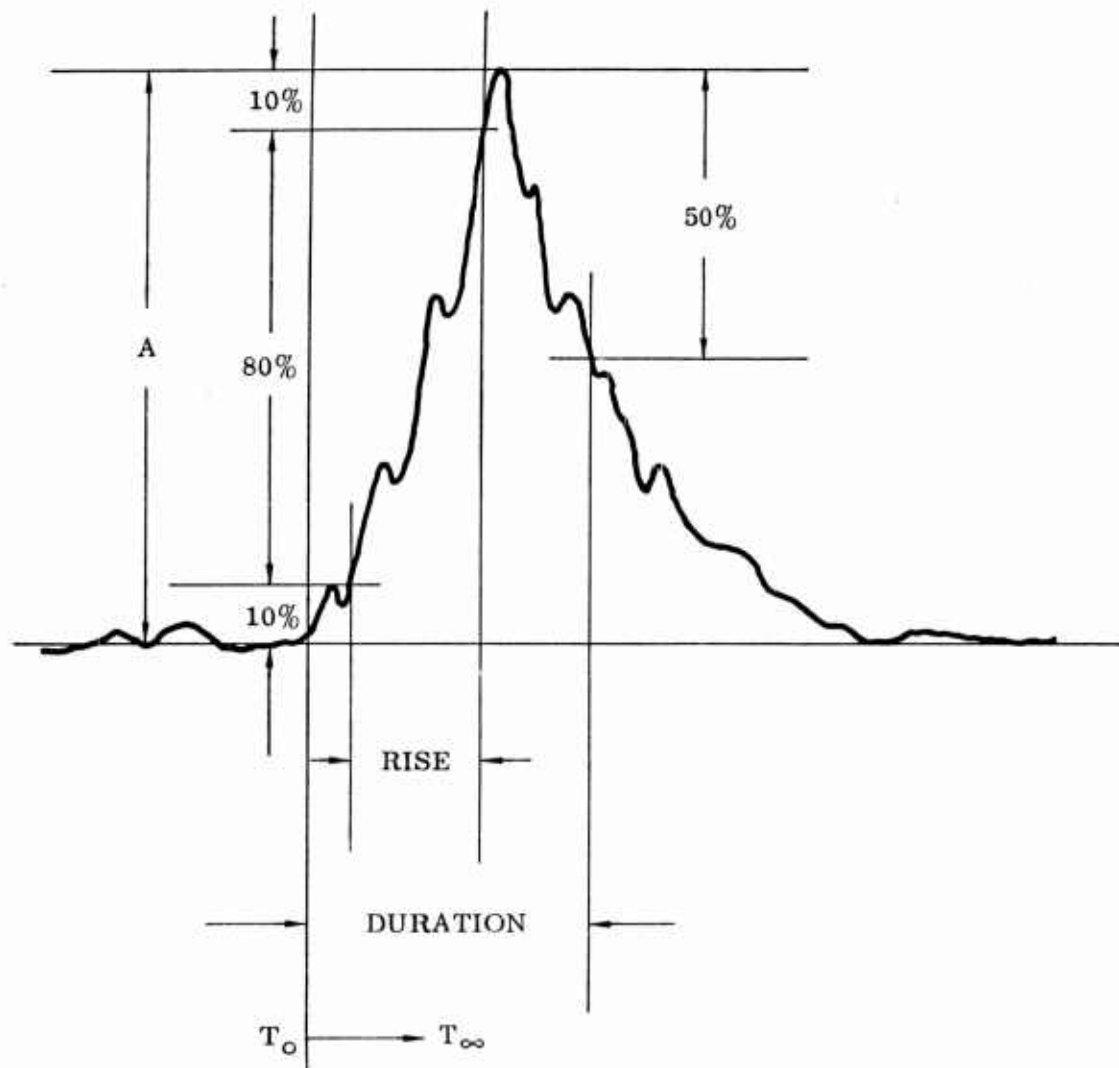

- A** = AMPLITUDE = STEP INPUT TO AVERAGE PEAK OF PULSE
RISE = TIME REQUIRED FOR BUILD-UP FROM 10% TO 90% OF PEAK AMPLITUDE
DURATION = TIME REQUIRED TO REACH 50% OF PEAK AMPLITUDE ON RELIEVING SIDE
RATE = $\frac{\text{AMPLITUDE}}{\text{RISE TIME}}$

Figure 45 Definition of Terms and Analysis Method for Oscillograph Record Interpretation

DUMMY WEIGHT 265 LB.
LAUNCH ALTITUDE 4000 FT.
LAUNCH AIRSPEED 65 KIAS

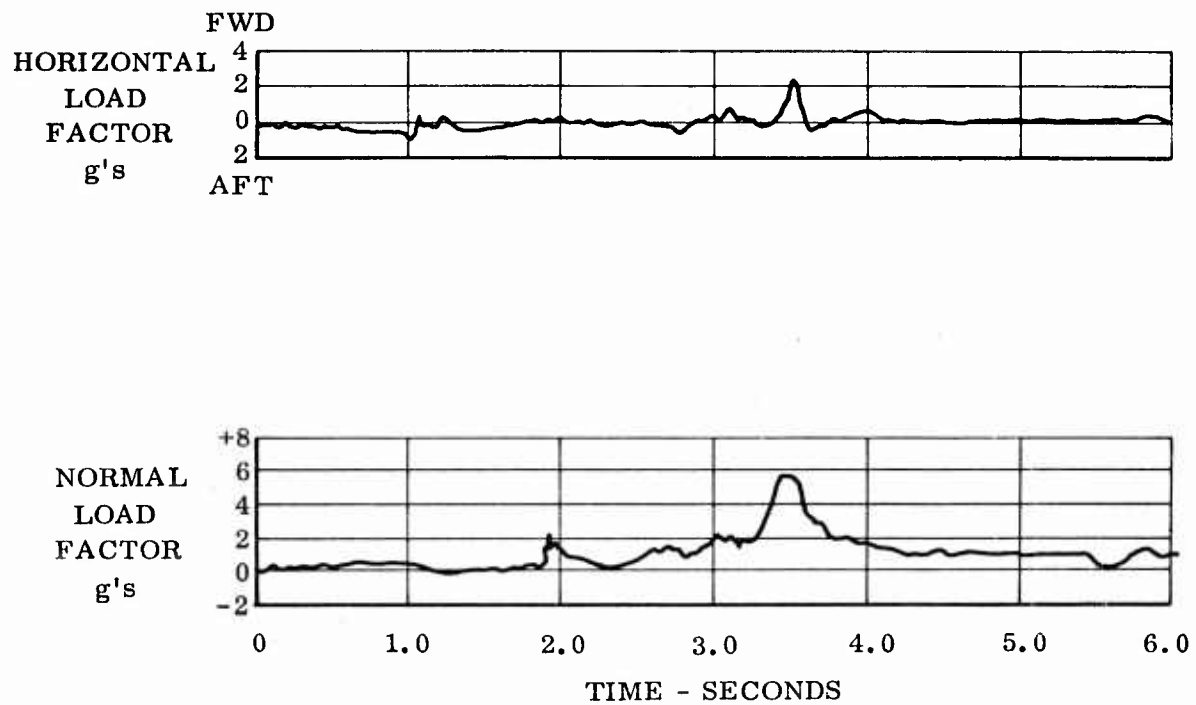

Figure 46 Opening Shock Loads - Load Factors

DUMMY WEIGHT 265 LB.
 LAUNCH ALTITUDE 4000 FT.
 LAUNCH AIRSPEED 65 KIAS

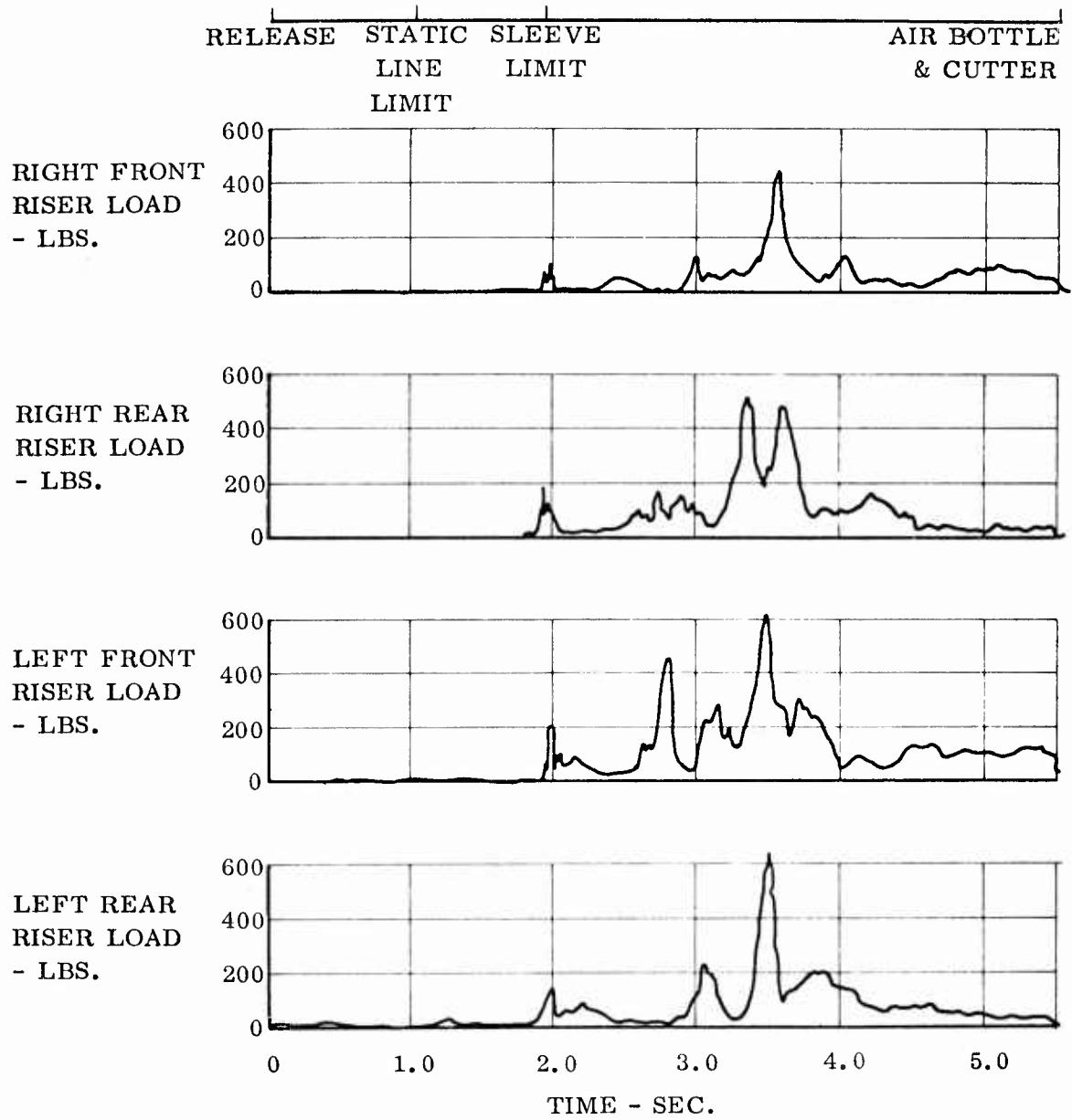

Figure 47 Opening Shock Loads - Individual Risers

accomplished for flight 91 and is shown in Figure 48. This summation of forces results in a maximum simultaneous total load application of 1800 pounds. Since acceleration in all three axes was not measured, an exact correlation of riser loads and acceleration forces cannot be made. However, by using only the vertical and horizontal g-force components, the resultant g-load is 6.2 g, as compared with 6.7 g obtained by the relationship $f = ma$. This calculated load factor indicates close correlation between the results obtained from two separate instrumentation systems.

Glide and Control

Glide performance data were obtained by cinetheodolite tracking. Figures 49, 50, and 51 present altitude-versus-time plots for three glider missions. The equilibrium rates of descent vary from 600 to 780 feet per minute. Stabilized ground speeds during these descents vary from 15 to 27 knots. The ground speed variation is due primarily to varying wind conditions. Winds during these flights averaged between 3 and 6 knots.

Satisfactory control was achieved during flight 91. Figure 52 shows the longitudinal-versus-lateral displacement history of this flight and the corresponding control inputs commanded. Marginal control was available on some of the previous flights in that the response was apparent but slow and maneuverability was limited. The control system used for this program allowed only a 6-inch riser line deflection. This amount of deflection appears marginal if the wing is insufficiently rigid or slightly out of rig. Greater riser line deflection would result in greater control and maneuverability. It is believed that this added control potential lies within the physical capability of a paratrooper.

Landing Loads and Velocities

The average landing loads, as measured by the normal and horizontal accelerometers for a maximum gross weight of 265 pounds, are 7.2 g and 11.9 g respectively. The duration of these accelerations is very short: 0.054 second normal and 0.065 second horizontal.

Of the four flights covered by cinetheodolite data, three were concluded with a flare maneuver. The vertical landing velocities varied from 10 to 13 feet per second, and the horizontal landing velocities varied from 22 to 26 feet per second. The generally accepted limits for parachutes are 18 feet per second vertically and 22 feet per second horizontally.

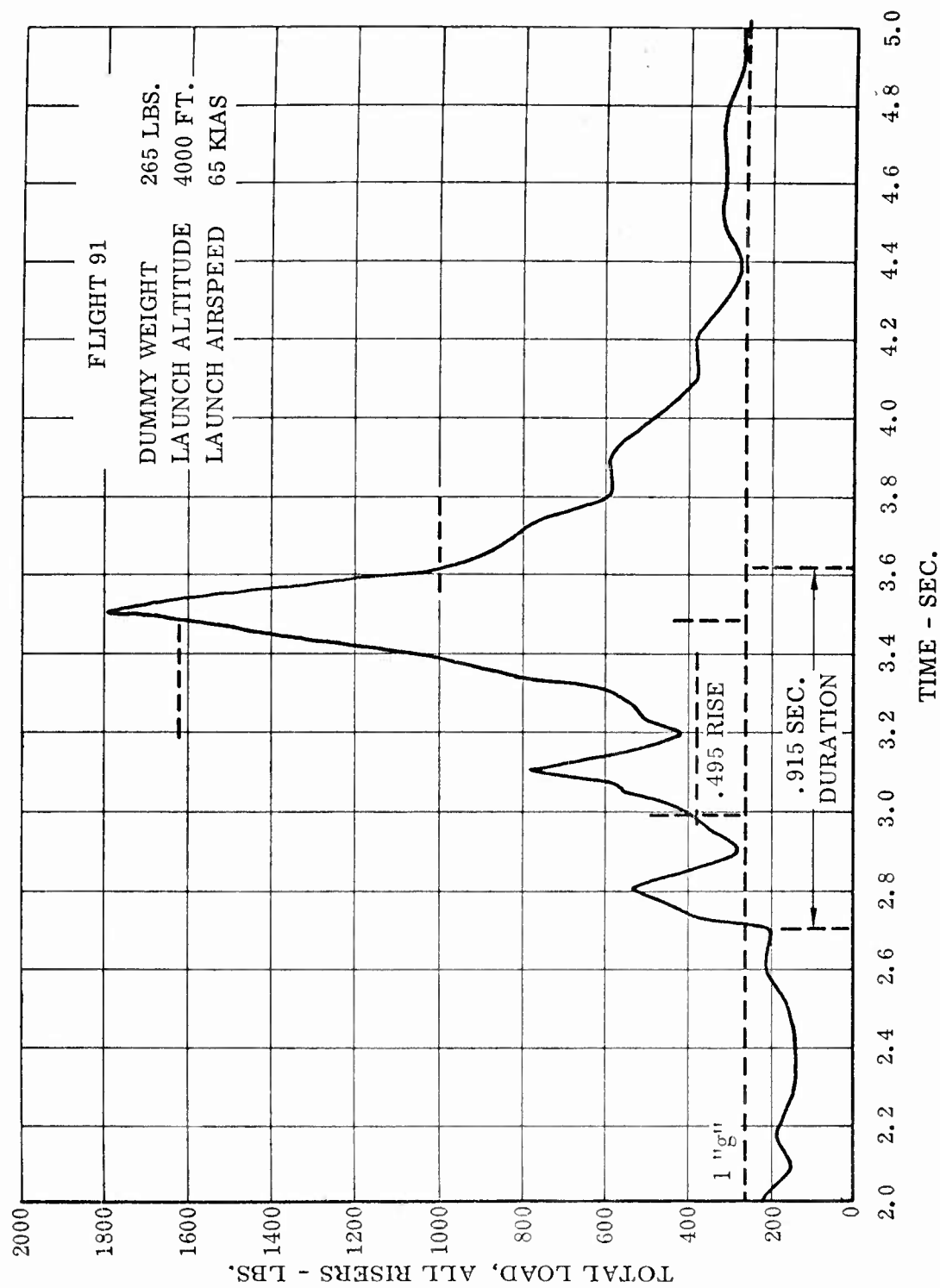

Figure 48 Composite of Riser Opening Shock Loads

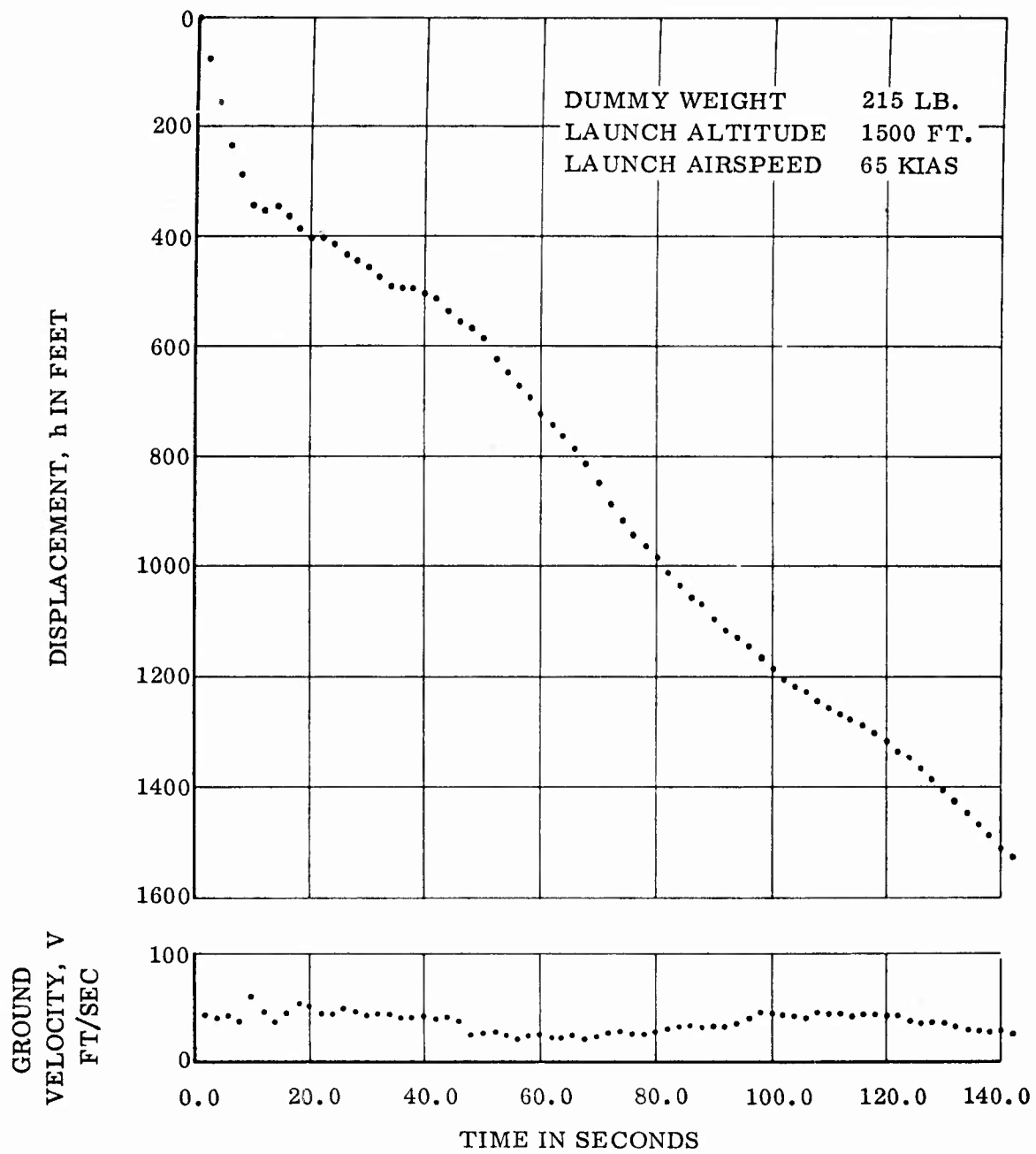

Figure 49 Time History - Flight No. 72

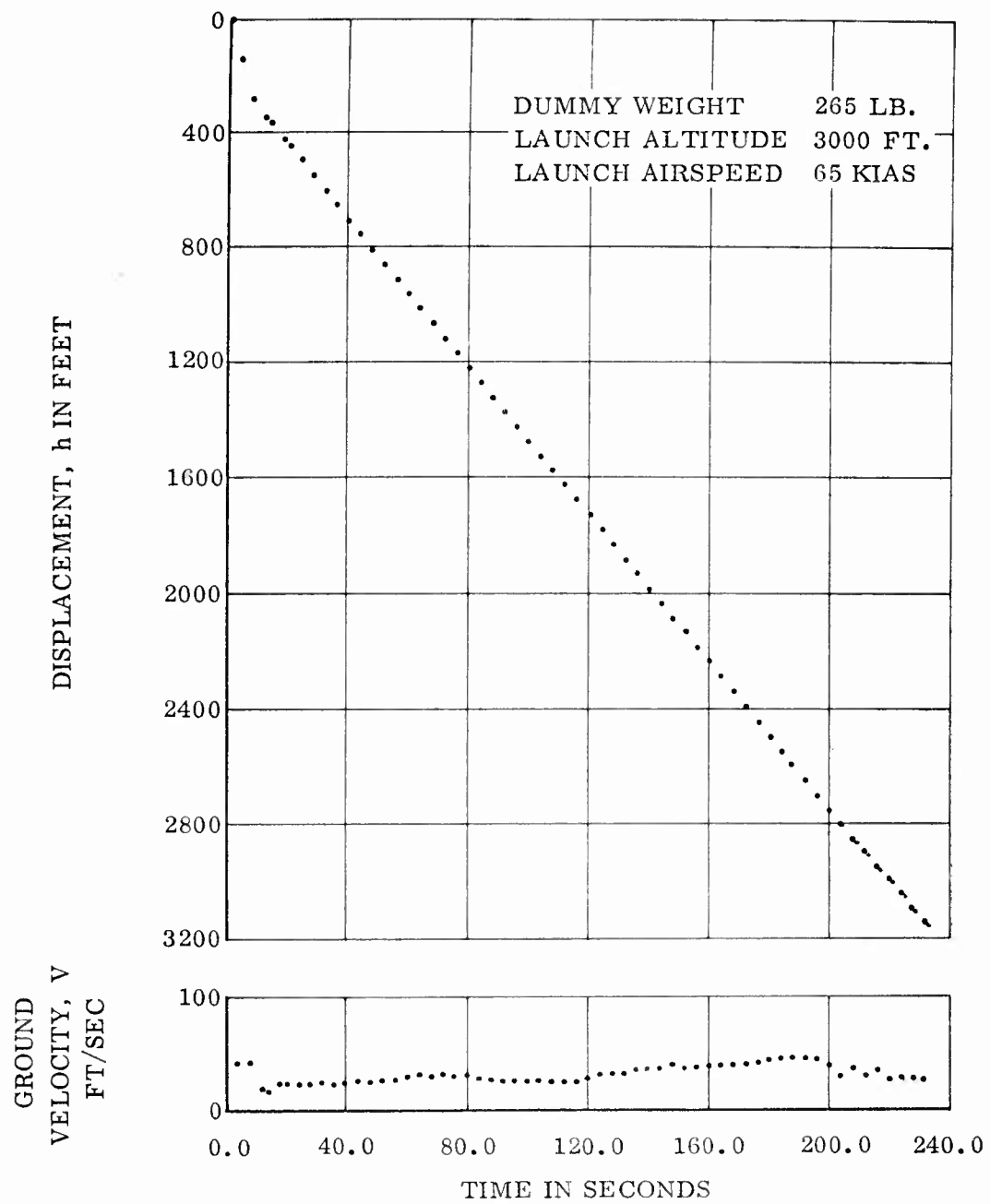

Figure 50 Time History - Flight No. 88

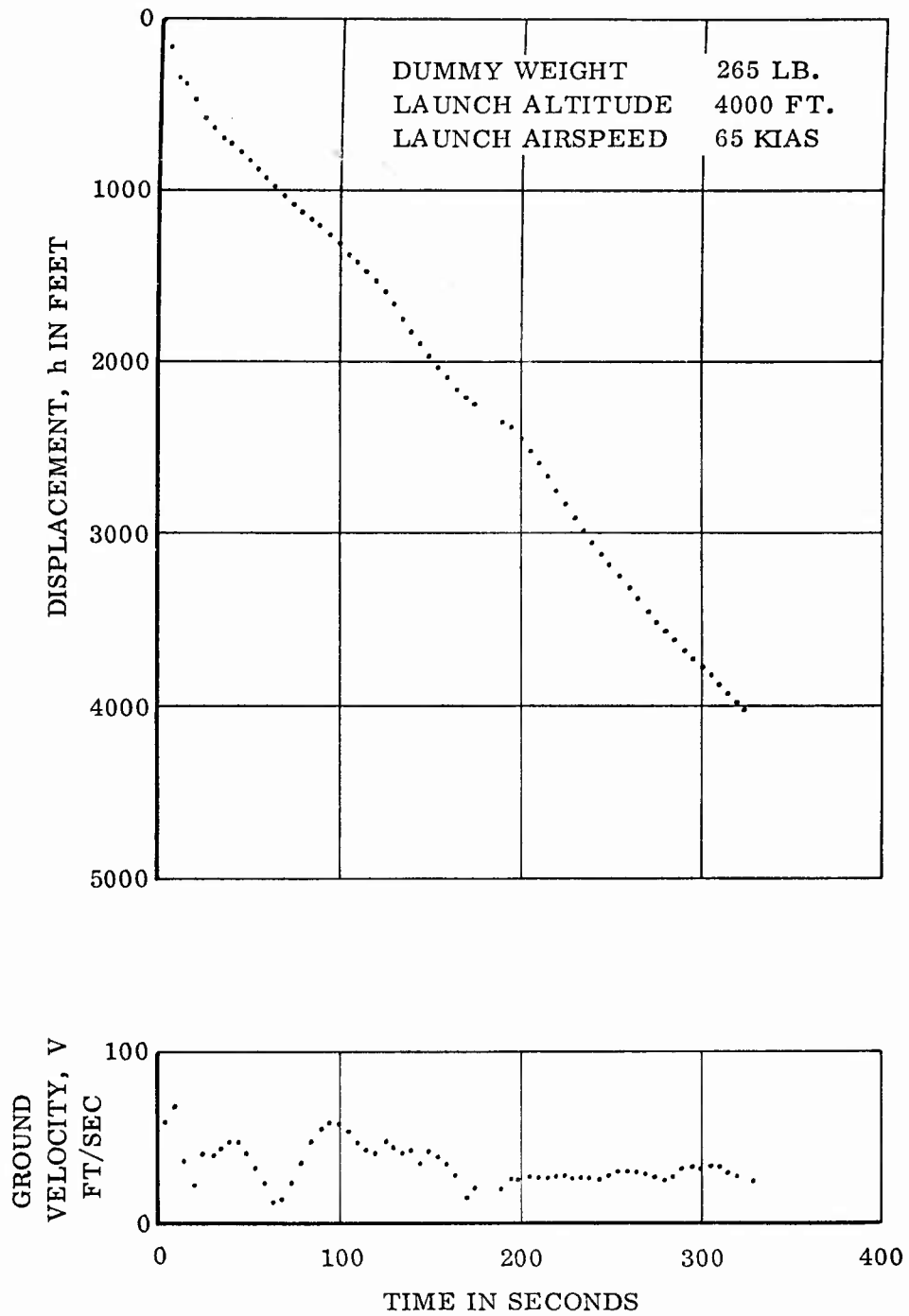
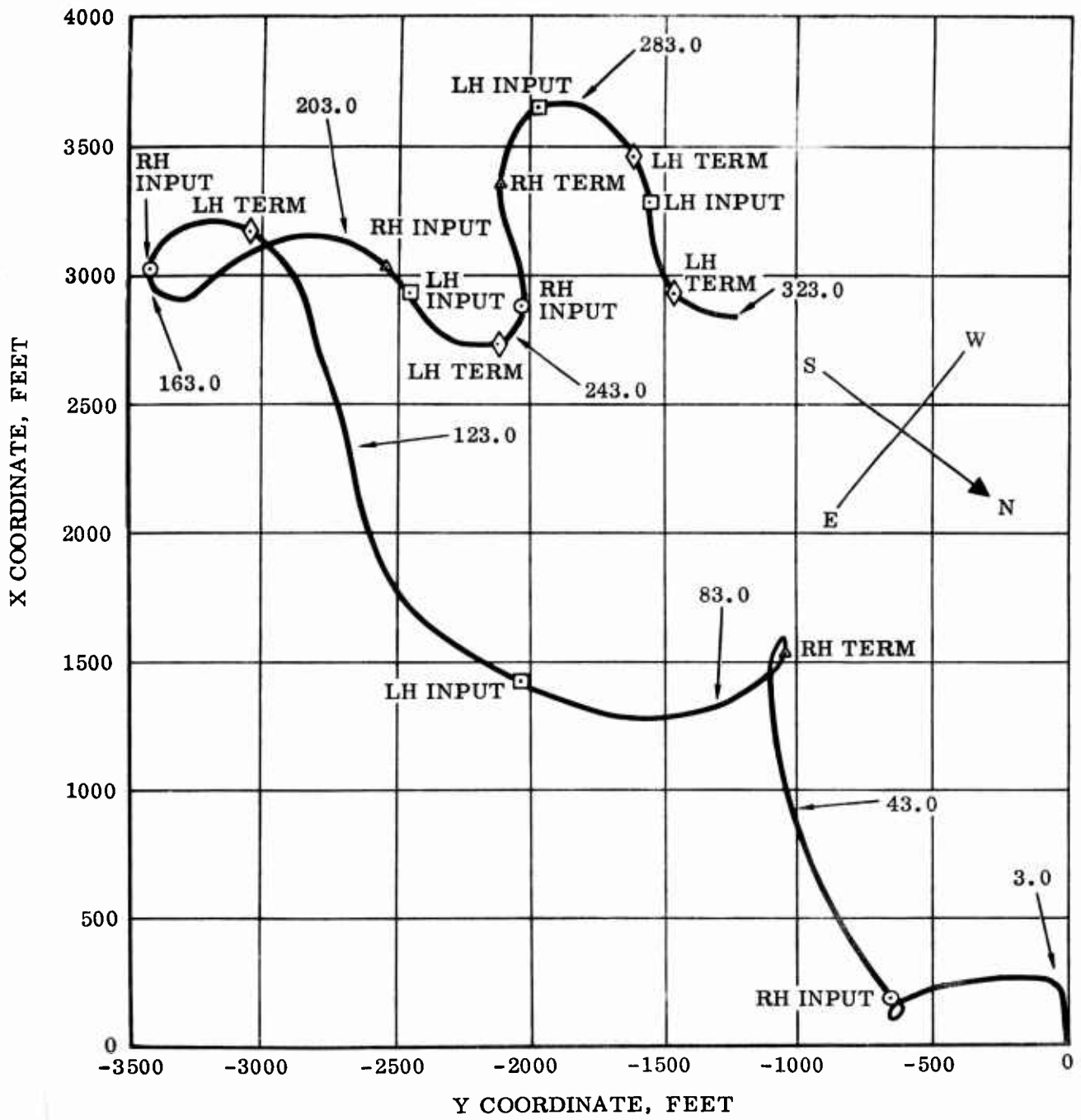

Figure 51 Time History - Flight No. 91



NOTES:

1

2

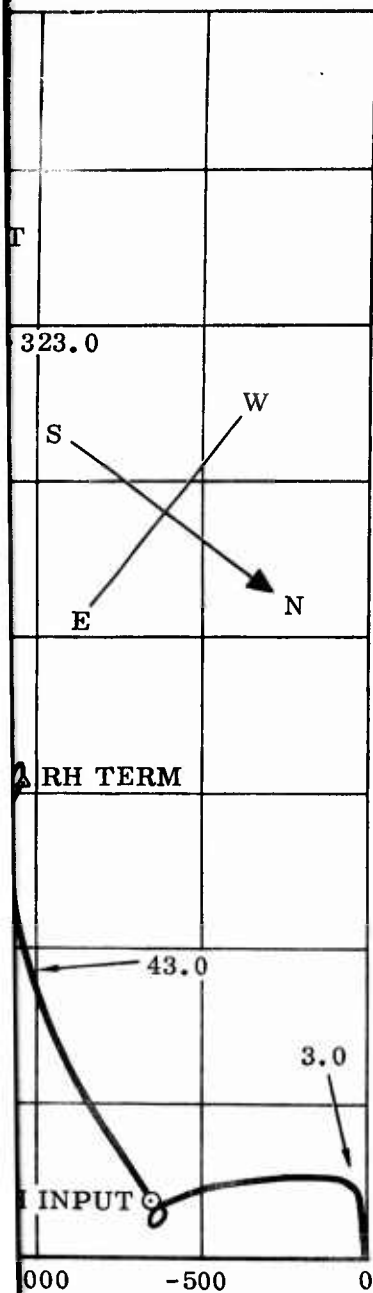

- NOTES: 1. NUMBERED CALL-OUTS ARE FLIGHT TIME IN SECONDS FROM LAUNCH
2. ○ R/H TURN COMMAND SIGNAL INITIATED
△ R/H TURN COMMAND SIGNAL TERMINATED
□ L/H TURN COMMAND SIGNAL INITIATED
◇ L/H TURN COMMAND SIGNAL TERMINATED
3. STABILIZATION TIME WAS 20.5 SECONDS
4. WIND DIRECTION AND VELOCITIES ARE SHOWN BY SCALED VECTORS.
VELOCITY SCALE: 1 INCH = 10 KNOTS

Figure 52 Flight Path - Longitudinal Versus Lateral Displacement -
Flight No. 91

Comparison of Measured and Predicted Glide Performance

A comparison of flight test and predicted glide performance is presented in Figure 53.

The flight test data points are plotted against the predicted values, with each symbol representing one flight. The straight line from the origin is the line of exact agreement. Points falling on this line would indicate perfect agreement between predicted and test data.

The flight test data, obtained by cinetheodolite tracking, are shown to be in close agreement with the predicted values. (See Figure 54)

The predicted performance was based on the following:

1. Lift and drag per Ryan Report 62B013 (original proposal).
2. Gross weight and altitude same as for flight test being compared.

Perhaps the best check of the predicted performance could be obtained by comparing the test and predicted data at the same angle of attack. A comparison on this basis is not possible, however, for the following reasons:

1. The glider was not instrumented to measure angle of attack.
2. The estimates of angles of attack for specific rigging geometries, with controls, are only approximate.
3. Pitch control was varied on most flights.

Since angle of attack cannot be used as a basis for checking the predicted performance, the comparison was made by using the flight test rate of descent as a starting point for predicting the other glide parameters. Thus, the test performance and the predicted performance are compared at the same rate of descent.

Obviously, this method of comparison does not check rates of descent as a function of angle of attack; however, on several flights, angle of attack was varied throughout the pitch range, and the test rates of descent were always within the range of the predicted values at the corresponding weight and altitude.

SYMBOL	FLT. NO.	RATE OF DESC. FLT. TEST F. P. S.	RATE OF DESC. PREDICTION BASIS F. P. S.	GLIDE VEL. FLT. TEST, F. P. S.	GLIDE VEL. PREDICTION BASIS F. P. S.	L/D FLT. TEST	L/D PREDICTION BASIS	REMARKS
○	72-8G-2	12.4	12.4	33.5	35.2	2.70	2.75	α VARIED DURING FLT; DATA PT. TAKEN BEFORE CONTROL INPUT α VARIED DURING FLT; DATA PT. TAKEN BEFORE CONTROL INPUT AFT KEEL LINES SHORTENED AFT KEEL LINES SHORTENED
□	82-6G-19	11.1	11.1	33.5	32.2	2.85	2.66	
●	88-8G-15	12.7	12.7	32.5	36.1	2.37	2.70	
◇	91-8G-17	11.2	11.2	29.0	29.8	2.40	2.42	

RATE OF DESCENT USED FOR
VELOCITY & L/D PREDICTIONS

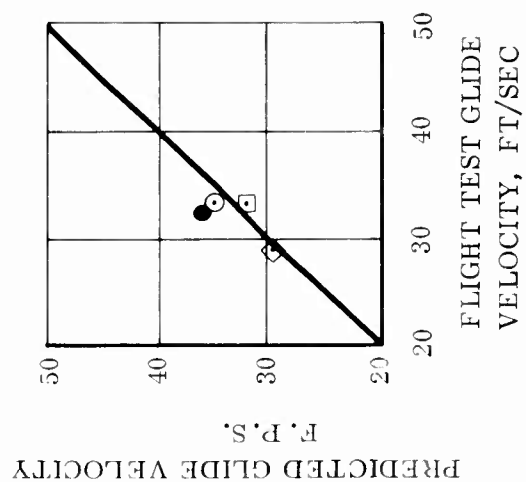
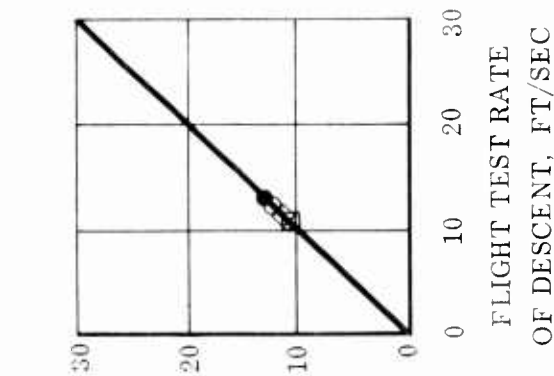

PREDICTED LIFT-TO-DRAG
RATIO

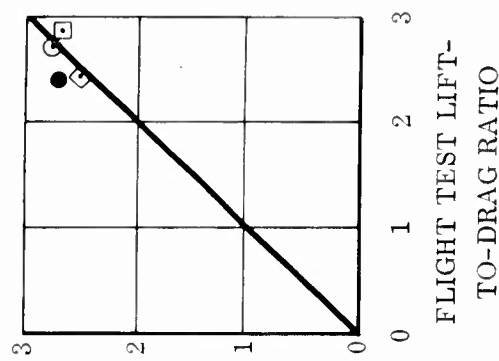

Figure 53 Comparison of Flight Test and Predicted Glide Performance

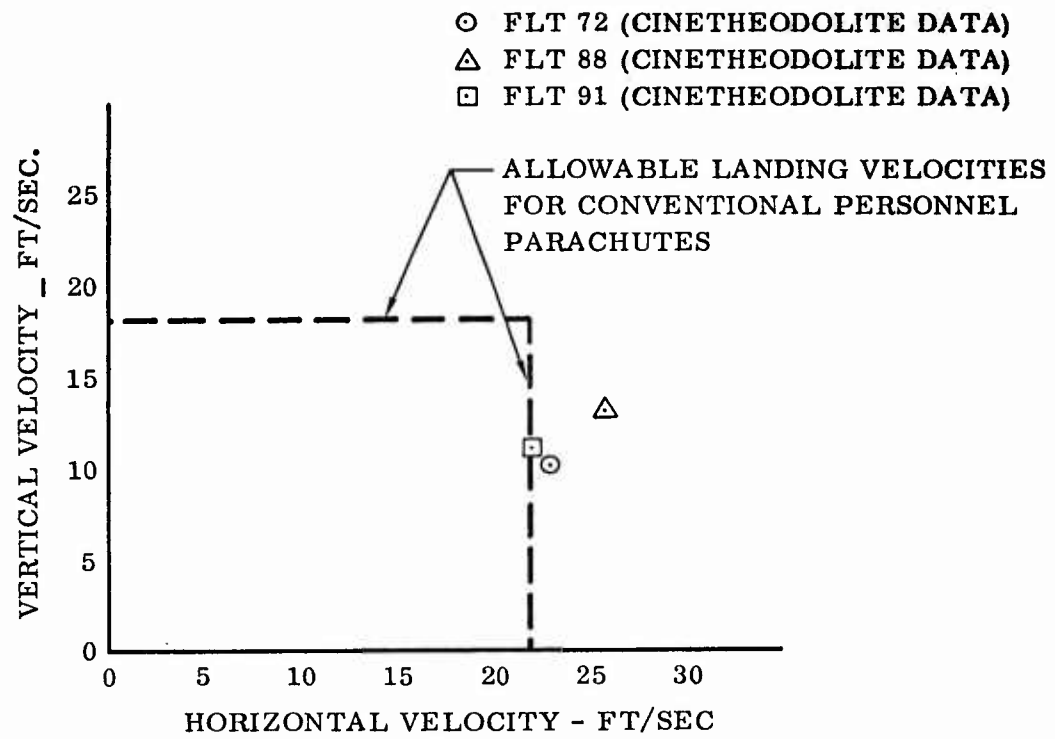

Figure 54 Paraglider Landing Velocities

Glide performance was obtained from cinetheodolite data as follows:

1. Rate of descent = $\frac{dh}{dt}$ = slope of altitude versus time curve.

2. The glide velocity obtained by cinetheodolite tracking is a ground velocity which varied throughout the flight due to the glider's turning in a moving air mass. The true airspeed was evaluated thus:

$$V_{\text{t.a.s.}} = \frac{\text{min. vel.} + \text{max. vel.}}{2} ,$$

with maximum and minimum velocities evaluated within the glide range being investigated.

3. Flight path angle = $\gamma = \sin^{-1} \frac{\dot{h}}{V}$.

4. Lift-to-drag ratio = $\frac{L}{D} = \frac{1}{\tan \gamma}$.

TABLE 1
CONFIGURATION CHANGES PRIOR TO EACH
FLIGHT TEST OPERATION

1. Basic.
2. Refined Line Stowage - Stowed lines on gussets.
3. 17' Static Line 36" pilot chute and sleeve (decrease opening shock load).
4. Added T. E. Doubler, eliminate "W" fold in wing, 11' sleeve, remove bungee mouth, positive activation for reefing cutters (structural beef-up, refine packing).
5. Returned to static line sleeve, for parachute lengthened line 1 30% of remaining length, L. E. lines 6 and 8, 50% of remaining length (dump trapped air; decrease opening shock), rotate bottle in pack (eliminate 180° twist upon deploy).
6. Original parachute rigging, add 6" to sleeve diameter, add gussets and doubler for attaching Pt. 7 (eliminate load path through the bottle).
7. 40 pound break cord to retain riser fittings, cutters for insurance only (decrease opening shock load by transitioning directly into the wing).
8. Gussets added to aft L. E. (loads distributed directly into membrane), all lines stowed on wing, (eliminate entanglement), reverse parachute lines and add cutter to each line.
9. Non-parachute lines grouped together and pulled toward center of wing, (locate lines to minimize entanglement), nose line in parachute lengthened 3 feet, over-all length the same (provide forward velocity - spill trapped air), 0 sec. bottle cutter (faster inflation of tubes).
10. Nose line not used for parachute, L. E. Lines #2 and 12 used for parachute - same length as #3 and 11 (provide forward velocity - spill trapped air), fold nose under prior to packing - foldline at point #2 and 12, wing half fold prior to insert in sleeve approximately 9 ft., paper inserted between fold in bottle area (separate lines from top and bottom fold).
11. No paper inserted between bottle and nose when in folded position.

12. Packing and rigging same as drop No. 3 except positive activation of reefing cutters and an 11 ft. sleeve (establish new reference point incorporating latest packing techniques), L. E. lines were inserted under the pleated membrane rather than on top.
13. Check flight characteristics and wing keel and L.E. rigidity by towing inflated wing aloft with H-21 helicopter.
14. No change.
15. Rigged wing for 30° , 75% keel length lines (38° possible stall).
16. Thimbles used on aft L. E. to replace grommets, check flight characteristics.
17. No changes, check flight characteristics.
18. Same as above.
19. Doubled line No. 6 and 8 with 1000 pound line for parachute (decrease line break) taped L.E. gussets No. 6 and 8 to tube (prevent line entanglement).
20. Wing reefed to hold parachute shape (investigate shock load regime), 500 ft. launch (better photo coverage), lines No. 6 and 8 doubled with piece of 500 pound test line shortened 3-1/2" in parachute (500 pound line elongation to diminish shock load), no inflation.
21. Same as drop 20 except not locked in parachute, and bottle charged for inflation (check stall buckling).
22. Rigging changed to 30° , 75% keel length.
23. No change.
24. No change.
25. No change.
26. No change.
27. New 1000 pound lines on gusset No. 6 and 8. Doubled Lines No. 6 and 8 with 550 pound nylon line, 3-1/2" shorter. (Take up shock). Initiated use of heat exchanger (pressure in bottle).
28. Replaced lines No. 6 and 8 as above. (evaluate stretch).

29. Replaced lines No. 6 and 8 as above. (Evaluate stretch). Air bottle spring shortened 1/2 inch. (More positive action).
30. Replaced lines No. 6 and 8 as above. (evaluate stretch).
31. Replaced lines No. 6 and 8 as above (evaluate stretch).
32. Replaced lines No. 6 and 8 as above (evaluate stretch). Install 1/4 in. metal collar on pneumatic spring. (eliminate spring stretch).
33. Replaced lines No. 6 and 8 as above (evaluate stretch).
34. Replaced lines No. 6 and 8 as above (evaluate stretch).
35. Replaced all parachute lines and No. 6 and 8 glider lines as above (lines stretched).
36. Replaced lines No. 6 and 8 with 3/16 in. polypropylene braided line between gusset and parachute ring. (evaluate line). Rig for parachute only.
37. Replaced lines No. 6 and 8 as above with 3/16 in. polypropylene line. (evaluate stretch).
38. Replaced lines No. 6 and 8 as above with 3/16 in. polypropylene line. (evaluate stretch).
39. Replaced lines No. 6 and 8 as above with 3/16 in. polypropylene line. (evaluate stretch).
40. Replaced all parachute lines, No's. 1, 4, 6, 7, 8, 10 with 1000 pound nylon line, used two half hitch knots at gussets, clove hitch with half hitch at rings. Stitched knots 3 in. (evaluate knots).
41. Air bottle cutter delay reduced to 0 sec. (evaluate pressure release sequence).
42. Replaced parachute lines as per drop 40. (lines stretched).
43. Used new reefing cutter sequence. 3 sec. forward riser, 6 sec. rear riser, 0 sec. bottle. (attempt to eliminate line pick-up during deployment).
44. Used new reefing cutter sequence. Wing 6 sec., bottle 2.5 sec. (check deployment transition).
45. No change.

46. Changed air bottle cutter to 1.5 sec. (evaluate deployment).
47. Replaced all parachute and glider lines as per drop 40. Used wing with 26 in., dial meter vent, center located at 58% keel length. (evaluate opening shock and oscillations). Rigged for parachute only.
48. The two wing OA-DZ-60 reefing cutter pins safety wired together. (insure simultaneous activation).
49. Same as drop 48 except used vented wing. (evaluate vented wing through full deployment).
50. Same as drop 48. Used maximum dummy weight (265 pounds) (check structure).
51. No change except dummy weight at 240 pounds (structural build-up).
52. Same as drop 48, dummy weight - 167 pounds.
53. Same as drop 48, dummy weight - 200 pounds.
54. Same as drop 48, except restrictor added to air pressure line (evaluate slower wing inflation), dummy weight 240 pounds.
55. Same as drop 54, dummy weight 200 pounds.
56. Same as drop 55.
57. Eliminated parachute mode. Reefed wing nose down to give forward C. G. (attempt to have wing follow a ballistic path during deployment).
58. No change.
59. Configuration as per drop 55.
60. Restrictor added to pressure feed line. Vented wing.
61. 16 gusset wing used. (distribute load more evenly throughout structural members). Single aft cutter for riser release (insure simultaneous riser release).
62. No change.
63. No change. Instrumented Dummy - 215 pounds.
64. Restrictor removed from pressure feed line (evaluate performance without) Dummy weight - 200 pounds.
65. No change. Instrumented dummy - 215 pounds.

66. No change. Dummy weight - 200 pounds.
67. Parachute line length change. Line No. 1 lengthened to 9 ft. Lines No. 3 and 11 shortened to 10' 6" (prevent line pick-up). Dummy weight 200 pounds.
68. No change.
69. No change.
70. No change.
71. No change.
72. No change. Instrumented Dummy - 215 pounds.
73. OA-D2 type reefing cutter replaced with M2-A1 type cutter on riser assembly. Latches modified to use 3000 lb. strap for securing latches. (Previously used 1000 lb. line not strong enough to withstand opening shock loads. Type OA-D2 cutter incapable of cutting 3000 lb. strap). Dummy weight 265 pounds.
74. No change. Instrumented dummy - 215 pounds.
75. No change.
76. Vented wing structural check at higher launch speed. Dummy weight 265 pounds. Parachute only.
77. Same as drop 75.
78. Single OA-D2 cutter used on aft riser. Latches secured by single 1000 pound line. Instrumented dummy - 215 pounds.
79. Single M2-A1 cutter used on aft riser. Two 1000 pound lines dead ended to latches. Instrumented dummy - 265 pounds.
80. Same as drop 78. Instrumented dummy 265 pounds.
81. Cutters per drop 79. Keel line lengths changed as follows:
No. 14 @ 14' 5.2", No. 15 @ 14' 9.5", No. 16 @ 13' 7.5", No. 16a @ 13' 2.0", No. 7 @ 13' 5 in. Instrumented dummy.
82. Number 2 and 12 line stowing change. A line length equal to the distance from gusset No. 2 to gusset No. 13, loosely stowed at gusset No. 2. Remaining line stowed in bundle on membrane near No. 13 keel gusset after the wing is pleated. The same procedure for line No. 12 (prevent line entanglement) Instrumented dummy - 215 pounds.

83. High capacity air bottle installed (205 cubic inches). (obtain greater tube pressure). Low altitude. Zero bottle cutter, 2 second wing cutter. Instrumented dummy - 215 pounds.
84. Configured as for drops No. 81 and 82 - Instrumented Dummy - 265 lbs.
85. No change.
86. No change.
87. No change.
88. No change.
89. No change.
90. No change.
91. Low capacity air bottle (125 cubic inches).
92. High capacity air bottle (205 cubic inches).

TABLE 2
DROP TEST CHRONOLOGY

Drop No.	Dummy Weight (Lb.)	Drop Alt. (Ft.)	Drop Vel. (KIAS)	Wing α (Deg.)	Bottle Press. (PSIG)	Line* Length Config.	Reefing Delay - Wing	Cutter (Sec.) Bottle	Glider Mode Attained?
1	240	1000	65	38	3350	A	1.5	1.5	No
2	240	2000	65	38	3350	A	6.0	6.0	No
3	105	1500	65	38	3100	A	1.5	1.5	No
4	105	1500	65	38	3100	A	1.5	1.5	No
5	105	2000	65	38	3150	B	1.5	1.5	No
6	105	1500	65	38	3150	C	1.5	1.5	No
7	105	1500	65	38	3150	C	0/1.5	0	No
8	105	2000	65	38	3200	C	2.5	1.5	No
9	240	2000	65	38	3150	D	2.5	0	No
10	240	2000	65	38	3300	E	4.0	1.5	No
11	240	2000	65	38	3300	E	4.0	1.5	No
12	240	2000	65	38	3300	F	6.0	1.5	No
13	240	1500	45	38	-	F	-	-	H-21 Tow
14	240	1500	5-10	38	-	F	-	-	H-21 Tow
15	240	2000	65	30	4100	G	6.0	1.5	No
16	240	1500	5-10	30	-	G	-	-	H-21 Tow
17	240	1500	5-10	30	-	G	-	-	H-21 Tow
18	240	2000	5-10	30	-	G	-	-	H-21 Tow
19	240	2000	65	30	4100	G	6.0	1.5	No
20	105	500	65	38	-	H	-	-	Rig. Chute Only
21	240	1000	65	38	3900	H	6.0	1.5	No
22	105	500	65	30	3900	I	6.0	1.5	Yes

*Ref. TABLE 3

TABLE 2
DROP TEST CHRONOLOGY

Drop No.	Dummy Weight (Lb.)	Drop Alt. (Ft.)	Drop Vel. (KIAS)	Wing α (Deg.)	Bottle Press. (PSIG)	Line * Length Config.	Reefing Delay - Wing	Cutter - (Sec.) Bottle	Glider Mode Attained?
23	240	1000	65	30	3900	I	6.0	1.5	No
24	105	1000	65	30	3900	I	6.0	1.5	No
25	105	1000	65	30	3900	I	6.0	1.5	Yes
26	240	1000	65	30	3900	I	6.0	1.5	No
27	167	1000	65	30	3900	I	6.0	1.5	Yes
28	105	1000	65	30	3900	I	6.0	1.5	No
29	167	1100	65	30	3900	I	6.0	1.5	Yes
30	105	1000	65	30	3900	I	6.0	1.5	No
31	240	500	65	30	3900	I	6.0	1.5	No
32	167	500	65	30	3900	I	6.0	1.5	No
33	167	700	65	30	3800	I	6.0	1.5	Yes
34	240	700	65	30	3900	I	6.0	1.5	No
35	167	700	65	30	3900	I	6.0	1.5	No
36	240	500	65	30	-	I	-	-	Rig. Chute Only
37	167	500	65	30	-	I	-	-	Rig. Chute Only
38	167	700	65	30	3900	I	6.0	1.5	Yes
39	240	700	65	30	3900	I	6.0	1.5	No
40	240	700	65	30	3900	I	6.0	1.5	No
41	240	700	65	30	3900	I	6.0	0	No
42	240	700	65	30	3900	I	6.0	0	No
43	240	700	65	30	4000	I	3/6	0	No
44	240	700	65	30	4000	I	6.0	1.5	Yes
45	240	700	65	30	4000	I	6.0	1.5	No

*Ref. Table 3

TABLE 2
DROP TEST CHRONOLOGY

Drop No.	Dummy Weight (Lb.)	Drop Alt. (Ft.)	Drop Vel. (KIAS)	Wing α (Deg.)	Bottle Press. (PSIG)	Line * Length Config.	Reefing Delay - (Sec.)	Cutter Bottle	Glider Mode Attained?
46	240	700	65	30	4000	I	6.0	1.5	No
47	105	1000	65	30	-	I	-	-	Rig. Chute Only
48	265	700	65	30	4000	I	6.0	1.5	No
49	167	700	65	30	4000	I	6.0	1.5	No
50	265	700	65	30	4000	I	6.0	1.5	No
51	240	700	65	30	4000	I	6.0	1.5	No
52	167	700	65	30	4000	I	6.0	1.5	Yes
53	200	700	65	30	4000	I	6.0	1.5	Yes
54	240	700	65	30	4000	I	6.0	1.5	Yes
55	200	1000	65	30	4000	I	6.0	1.5	No
56	200	1000	65	30	4000	I	6.0	1.5	Yes
57	200	1000	65	30	4000	J	6.0	1.5	No
58	200	1000	65	30	4000	J	6.0	1.5	No
59	200	2000	65	30	4000	K	6.0	1.5	No
60	200	1000	65	20	4000	K	6.0	1.5	No
61	200	1000	65	30	4000	L	6.0	1.5	No
62	200	2000	65	30	4000	L	6.0	1.5	No
63	215	2000	65	30	4000	L	6.0	1.5	No
64	200	1000	65	30	4000	L	6.0	1.5	No.
65	215	2000	65	30	4000	L	6.0	1.5	No
66	200	2000	65	30	4000	L	6.0	1.5	No
67	200	2000	65	30	4000	M	6.0	1.5	No
68	200	2000	65	30	4000	M	6.0	1.5	Yes

*Ref. TABLE 3

TABLE 2
DROP TEST CHRONOLOGY

Drop No.	Dummy Weight (Lb.)	Drop Alt. (Ft.)	Drop Vel. (KIAS)	Wing α (Deg.)	Bottle Press. (PSIG)	Line * Length Config.	Reefing Delay - Wing	Cutter (Sec.)	Bottle	Glider Mode Attained?
69	200	2000	65	30	4000	M	6.0	1.5	4000	Yes
70	200	2000	65	30	4000	M	6.0	1.5	4000	No
71	200	2000	65	30	4000	M	6.0	1.5	4000	Yes
72	215	1500	65	30	4000	M	6.0	1.5	4000	Yes
73	265	2000	85	30	4000	M	4.0	1.5	4000	No
74	215	4000	65	30	4000	M	4.0	1.5	4000	No
75	215	4000	65	30	4000	M	4.0	1.5	4000	No
76	265	2000	85	30	-	M	-	-	-	Rig. Chute Only
77	215	4000	65	30	4000	M	4.0	1.5	4000	No
78	215	2000	65	30	4000	M	6.0	1.5	4000	Yes
79	265	3000	65	30	4000	M	4.0	1.5	4000	No
80	265	3000	65	30	4000	M	4.0	1.5	4000	No
81	265	3000	65	30	4000	N	4.0	1.5	4000	No
82	215	3000	65	30	4000	N	4.0	1.5	4000	Yes
83	215	480	65	30	3400	N	2.0	0	3400	No
84	265	3000	65	30	3400	N	4.0	1.5	3400	No
85	265	3000	65	30	3400	N	4.0	1.5	3400	Yes
86	265	3000	65	30	3400	N	4.0	1.5	3400	Yes
87	265	3000	65	30	3400	N	4.0	1.5	3400	No
88	265	3000	65	30	3400	N	4.0	1.5	3400	Yes
89	265	4000	65	30	3400	N	4.0	1.5	3400	Yes
90	265	4000	65	30	4100	N	4.0	1.5	4100	Yes
91	265	4000	65	30	3400	N	4.0	1.5	3400	Yes

*Ref. TABLE 3

TABLE 3
EVOLUTION OF PARAGLIDER LINE LENGTHS

KEY-LINE LENGTH CONFIG.	A	B	C	D	E	F	G	H	I	J	K	L	M	N
FLIGHT TEST ORDER (FTO) NUMBER	1 THRU 4	5 THRU 8	6 THRU 8	9	10 THRU 11	12 THRU 14	15 THRU 19	20 THRU 21	22 THRU 26	27 THRU 28	29 THRU 30	31 THRU 33	34 THRU 36	37 THRU 39
WING ANGLE OF ATTACK	38°	38°	38°	38°	38°	38°	38°	38°	30°	30°	30°	30°	30°	30°
PARACHUTE LINE NUMBER														
1	6'0"	12'6.5"	6'0"	9'0"	N/A	6'0"			6'0"	7'0"	6'0"	6'0"	9'0"	9'0"
3 & 11	11'6"								11'6"	N/A	11'6"	11'6", 10'6"	10'6"	10'6"
6 & 8	6'5.5"	14'7"	6'5.5"						6'5.5"	N/A	6'5.5"		6'5.5"	6'5.5"
7	11'0"								11'0"	N/A	11'0"		11'0"	11'0"
2 & 12	N/A			N/A	11'6"	N/A			N/A	5'8"	N/A		N/A	N/A
13	N/A								N/A	5'8"	N/A		N/A	N/A
WING LINE NUMBER														
1	21'8"					21'8"	20'9"	21'8"	20'9"		20'9"	21'0"		21'0"
2 & 12	18'6"					18'6"	17'11"	18'6"	17'11"		17'11"	17'7"		17'7"
3 & 11	16'3"					16'3"	15'10"	16'3"	15'10"		15'10"	15'7"		15'7"
4 & 10	16'6"					16'6"	16'3"	16'6"	16'3"		16'3"	16'0"		16'0"
5 & 9	15'2"					15'2"	15'2"	15'2"	15'2"		15'2"	15'4"		15'4"
5A & 9A	N/A					N/A	N/A	N/A	N/A		N/A	14'11"		14'11"
6 & 8	16'3"					16'3"	16'2"	16'3"	16'2"		16'2"	16'0"		16'0"
7	13'9"					13'9"	13'11"	13'9"	13'11"		13'11"	14'4"		13'5"
16A	N/A					N/A	N/A	N/A	N/A		N/A	14'0"		13'2"
16	13'6"					13'6"	13'6"	13'6"	13'6"		13'6"	14'4"		14'4"
15	14'7"					14'7"	14'5"	14'7"	14'5"		14'5"	15'5"		15'5"
14	14'7"					14'7"	14'2"	14'7"	14'2"		14'2"	15'0"		14'5.2"
13	17'1"					17'1"	16'5"	17'1"	16'5"		16'5"	17'6"		17'6"

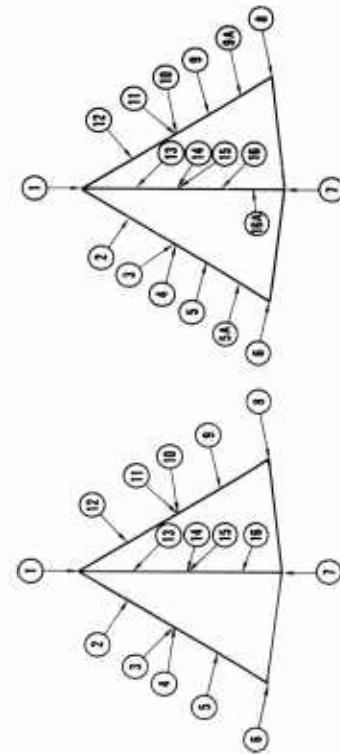

TABLE 4
 OPENING SHOCK LOADS DATA
 (ACCELEROMETER)

Drop No.	Vert. "g"	Rate (g/sec.)	Dur. (Sec.)	Horiz. "g"	Rate (g/sec.)	Dur. (Sec.)	Dummy Weight (Lb.)
63	5.1	15.8	1.000	3.5	50.6	.300	215
65	6.1	35.9	.275	1.9	9.7	.275	215
72	7.5	150.0	1.250	1.5	25.0	.075	215
74	5.9	9.8	.900	0.1	57.0	.020	215
79	5.1	7.80	.775	1.8	24.0	.120	265
82	6.8	195.0	.125	3.0	24.0	.210	215
84	6.8	22.7	.550	1.9	9.5	.380	265
85	5.1	8.5	.850	0.5	27.0	.090	265
86	5.3	6.6	1.250	1.4	18.3	.200	265
88	4.5	64.3	.150	3.0	60.0	.100	265
89	5.7	43.8	.360	1.8	35.8	.110	265
90	5.7	12.7	.700	0.7	17.2	.200	265
91	5.7	14.4	.750	2.4	26.0	.150	265

TABLE 5
 LANDING SHOCK LOADS DATA
 (ACCELEROMETER)

Drop No.	Vert. "g"	Rate (g/Sec.)	Dur. (Sec.)	Horiz. "g"	Rate "g"	Dur. (Sec.)	Dummy Weight (Lb.)
72	11.3	11300	.050	9.0	150	.075	215
85	5.4	540	.040	13.5	1350	.090	265
86	7.3	7270	.075	12.2	12250	.075	265
88	4.2	4200	.020	7.8	390	.035	265
91	11.7	11700	.030	14.2	14200	.050	265

TABLE 6
OPENING SHOCK LOADS DATA (STRAIN GAGE)

Drop No.	Riser #1		Riser #2		Riser #3		Riser #4					
	Load Rate (Lb.) (Lb/Sec.)	Dur. (Sec.)	Load Rate (Lb.) (Lb/Sec.)	Dur. (Sec.)	Load Rate (Lb.) (Lb/Sec.)	Dur. (Sec.)	Load Rate (Lb.) (Lb/Sec.)	Dur. (Sec.)				
63	430	688	.735	414	1090	.450	316	1505	.300	310	816	.760
65	435	1085	.600	485	538	1.012	630	750	.950	650	4330	.300
72	560	2430	.360	555	1980	.310	470	6710	.140	300	1365	.260
82	370	4630	.210	606	5050	.200	190	2720	.300	473	5240	.340
84	585	1890	.700	51	1020	.110	77	593	.250	605	1440	.810
85	299	1190	.500	230	1920	.290	453	1030	.570	490	5450	.270
86	540	2350	.450	344	1010	.490	339	2120	.270	462	4200	.250
88	281	905	.510	875	9730	.250	497	4510	.250	800	7270	.230
90	325	930	.570	770	1880	.560	860	4100	.350	220	1370	.390
91	470	2140	.320	515	4730	.200	615	7250	.120	600	6230	.210

TABLE 7
 AVERAGE OF OPENING SHOCK LOADS
 (ACCELEROMETER)

Gross Weight (Lb.)	Normal "g"	Rate (g/sec.)	Dur. (Sec.)	Horiz. "g"	Rate (g/sec.)	Dur. (Sec.)
215	6.3	81.3	0.71	2.0	33.3	0.17
265	5.5	22.6	0.67	1.7	27.2	0.17

TABLE 8
 AVERAGE OF LANDING SHOCK LOADS
 (ACCELEROMETER)

Gross Weight (Lb.)	Normal "g"	Rate (g/sec.)	Dur. (Sec.)	Horiz. "g"	Rate (g/sec.)	Dur. (Sec.)
215*	11.3	11,300	0.050	9.0	150	0.075
265	7.2	5,930	0.054	11.9	9,550	0.065

* Only one landing at this gross weight.

TABLE 9

AVERAGE OF RISER OPENING SHOCK LOADS
(STRAIN GAGE)

Gross Weight Lb.	Riser No.	Load Lb.	Rate Lb/sec.	Dur. Sec.
215	1	450	2210	0.476
	2	515	2165	0.493
	3	400	2920	0.422
	4	435	2940	0.415
	Total		1800	2560
265	1	415	1570	0.508
	2	465	3380	0.316
	3	475	3270	0.302
	4	530	4330	0.360
	Total		1885	3140

APPENDIX

INSTRUMENTED FLIGHTS ON WHICH USEFUL DATA WERE OBTAINED

<u>Flight Test Report Number</u>		<u>Page</u>
63-2R-24	October 11, 1962	144
65-2R-25	October 12, 1962	145
72-8G-2	October 24, 1962	146
74-6G-18	October 26, 1962	148
79-8G-7	November 5, 1962	149
82-6G-19	November 8, 1962	150
84-8G-11	November 9, 1962	151
85-8G-12	November 13, 1962	152
86-8G-13	November 14, 1962	153
88-8G-15	November 16, 1962	154
89-8G-16	November 20, 1962	155
90-6G-20	November 21, 1962	156
91-8G-17	November 21, 1962	157

Note: The Flight Test Number designates three things, as the following example illustrates:

63-2R-24

24th Test for this wing

S/N of wing used

63rd Test conducted during this program

October 11, 1962

FLIGHT TEST REPORT NO. 63-2R-24

MODEL NO. 149

- Objectives:** First attempt at drop of instrumented dummy through full deployment to obtain cinetheodolite and oscillograph data. Alternate objective was to check out emergency parachute operation.
- Results:** Launch and initial parachute characteristics were satisfactory. Wing configuration was not attained because tubes did not inflate. Emergency parachute deployed at approximately 1000 feet altitude.
- Description:** The drop was initiated from 2000 feet at 65 knots indicated air-speed. Initial parachute characteristics were satisfactory with only slight oscillations. Air bottle actuation was successful, but the tubes did not inflate, causing the nose of the wing to bend upward. The emergency parachute was deployed at 1000 feet altitude and the instrumented dummy landed safely.
- Data:** Test Conditions
Surface wind velocity - calm
Dummy weight - 215 pounds
Pack configuration - "C": restrictor in air bottle line
Bottle capacity - 125 in³ (4000 psig)
- Records
Oscillograph data were obtained. Oscillograph records, after emergency parachute deployment are not available. See Tables 4 and 6 for data summary.
- Remarks:** No damage to test equipment. Post-flight inspection revealed a slight rip in the underside of the L/H leading edges, possibly accounting for inflation failure.

October 12, 1962

FLIGHT TEST REPORT NO. 65-2R-25

MODEL NO. 149

Objectives: Instrumented dummy drop Number 2, to obtain oscillograph data for opening shock and ground impact loads.

Results: Glider did not develop properly and went into a low rate of descent spiral. Emergency parachute activated at approximately 800 feet but did not deploy properly. No damage to dummy on landing.

Description: The drop was initiated from 2000 feet at 65 knots indicated air-speed. Parachute mode, if any, was of very short duration. Air bottle functioned properly but aft line foul prevented development of full wing mode. Glider spiralled down at a high rate of rotation with a relatively low rate of descent. No line pick-up was observed. The emergency parachute did not deploy properly due to the low rate of descent. No damage to the instrumented dummy occurred on landing.

Data: Test Conditions
Launch wind velocity - w 3 kts SSW
Dummy weight - 215 pounds
Pack configuration - "C"
Bottle capacity - 125 in³ (4000 psi)

Records
Oscillograph, but no cinetheodolite data was obtained. See Tables 4 and 6 for data summary.

Remarks: None

October 24, 1962

FLIGHT TEST REPORT NO. 72-8G-2

MODEL NO. 149

Objective: To investigate instrumented dummy drop:

1. Opening shock and landing impact loads.
2. Available control.

Results: Normal launch with parachute mode being slow to deploy properly, thus delaying wing formation. Final wing configuration was stable. Response to control inputs was sluggish but the glider did respond to the command signals. Glider responded properly to the flare command and resulting landing loads were light.

Description: The drop was initiated from 1500 feet at 65 knots indicated air-speed. Initial parachute mode displayed considerable breathing before fully deploying. A gore tuck developed during the chute mode which delayed the glider configuration. Response to control commands was sluggish but improved as trailing edge flutter decreased. Nose down trim and left turn commands were executed during the flight. Flare was initiated at an altitude of approximately 10 feet with the proper glider response resulting in light landing loads.

Data: Test Conditions

Surface wind velocity - 6-8 kts. SW

Dummy weight - 215 pounds

Pack configuration - "D" 16 Gusset wing

Bottle capacity - 125 in³ (4000 psi)

Records

Cinetheodolite and oscillograph data were obtained. See Tables 4, 5, and 6 for data summary.

FLIGHT TEST REPORT NO. 72-8G-2 (continued)

Remarks: Post flight inspection revealed:

- a. L/H control riser - 5-1/2 inches from dummy to fitting. 55
- b. R/H control riser - fully extended.
- c. L/H riser drum actuator - frozen in hard over position.
- d. R/H riser drum actuator - shaft sheared.

October 26, 1962

FLIGHT TEST REPORT NO 74-6G-18

MODEL NO. 149

Objective: Check trailing edge flutter conditions at various angles of attack: (34°, 38°, and 42°)

Results: Normal launch with a good parachute mode. Glider mode developed with approximately 4 feet of nose tuck. Emergency parachute deployed at approximately 1500 feet altitude.

Description: The drop was initiated from 4000 feet at 65 knots indicated air-speed. Initial parachute mode and air bottle operation was satisfactory. Nose tuck occurred during the wing deployment when, upon line release, the line became entangled. Glider shape with approximately 4 feet of nose tuck was formed and did not respond to turn commands. Emergency parachute was deployed at approximately 1500 feet. Landing was normal with no damage to the instrumented dummy.

Data: Test Conditions

Launch wind velocity - 9 kts. NE

Dummy weight - 215 pounds

Pack configuration - "E"

Bottle capacity - 125 in³ (4000 psi)

Records

Oscillograph data was obtained. See Table 4 for data summary.

Remarks: Post flight inspection revealed leak in air tubes.

November 5, 1962

FLIGHT TEST REPORT NO. 79-8G-7

MODEL NO. 149

Objective: Angle of attack investigation.

Results: Launch and parachute modes were satisfactory. Wing configuration not attained. Emergency chute deployed.

Description: The drop was initiated from 3000 feet at 65 knots indicated air-speed. Parachute mode was satisfactory. Went into wing configuration with line pickup in nose down attitude. Attempted control inputs to shake loose lines and correct spiral without effect. Emergency parachute deployed with wing in spiral to impact.

Data: Test Conditions
Launch wind velocity - 3 knots WNW
Dummy weight - 265 pounds
Pack configuration - "F" 16 Gusset wing
Bottle capacity - 125 in³ (4000 psi)

Records
Oscillograph data were obtained. See Table 4 for data summary.

Remarks: Post flight tube pressure 4.5 psig.

November 8, 1962

FLIGHT TEST REPORT NO. 82-6G-19

MODEL NO. 149

- Objective:** Evaluate flight and control characteristics at various angles of attack (30°, 34°, 38°, and 42°).
- Results:** Launch and deployment to the glider configuration was successful. The above objectives were evaluated throughout the descent.
- Description:** The drop was initiated from 3000 feet at 65 knots indicated air-speed. Full deployment to glider configuration was successful with no commands required to level wings. A slow flutter condition on the L/H trailing edge was alleviated by nose up trim commands. The wing began a slow turn to the left. Additional nose up trim commands increased the left turn rate. Right trim command input had no apparent effect. Flare command was initiated successfully.
- Data:** Test Conditions
- Launch wind velocity - 7 kts. E.
- Dummy weight - 215 pounds
- Pack configuration - "F"
- Bottle capacity - 125 in³ (3000 psi)
- Records
- Oscillograph and cinetheodolite data were obtained. See Tables 4 and 6 for data summary.
- Remarks:** Post flight inspection revealed 2 psig pressure in wing tube. There were no apparent punctures.

November 9, 1962

FLIGHT TEST REPORT NO. 84-8G-11

MODEL NO. 149

Objective:

1. Obtain loads data with heavy gross weight dummy.
2. Evaluate flight and control characteristics at various angles of attack.

Results: Good deploy and parachute formation. Glider mode initiated, but air tubes did not fill. Emergency parachute did not deploy.

Description: The drop was initiated from 3000 feet at 65 knots indicated air-speed. Good deploy and good parachute mode. Glider did not form as the air tube did not fill but no line entanglement noted. Control inputs attempted to check high rate of descent of wing were ineffective. Emergency parachute failed to deploy.

Data: Test Conditions

Surface wind velocity - 2 knots - SSW

Dummy weight - 265 pounds

Pack configuration - "F" 16 Gusset wing - Short keel lines

Bottle capacity - 205 in³ (3400 psi)

Records

Oscillograph data was obtained. See Tables 4 and 6 for data summary.

Remarks: Post flight inspection revealed positive air bottle reefing cutter action but the actuation spring failed to release the air bottle plunger.

November 13, 1962

FLIGHT TEST REPORT NO. 85-8G-12

MODEL NO. 149

- Objective:** To determine effects of lateral control inputs on directional control of the IDG Glider.
- Results:** Launch and deployment to wing configuration satisfactory, leaving wing in slight right turn. Single and differential control commands produced negligible effects. Flare mode did not function.
- Description:** The drop was initiated from 3000 feet at 65 knots indicated air-speed. A stable wing in a slight right turn was established 20 seconds after launch. Left turn command appeared to correct glider attitude. Additional single turn commands had no apparent effect. Differential lateral control commands produced no apparent effects. Flutter was observed at the trailing edge of both wing panels. Flare command was ordered but no response was noted.
- Data:** Test Conditions
Launch wind velocity - 7 knots. S
Dummy weight - 265 pounds
Pack configuration - "F" 16 Gusset wing - Short keel lines
Bottle capacity - 205 in³ (3400 psi)
- Records
Oscillograph data was obtained. See Tables 4, 5, and 6 for data summary.
- Remarks:** Post drop investigation revealed that flare solenoid was inoperative.

November 14, 1962

FLIGHT TEST REPORT NO. 86-8G-13

MODEL NO. 149

Objective: Investigate lateral control effectiveness from ground control inputs.

Results: Launch and wing deployment were satisfactory. The flight control system did not exhibit adequate range of motion to produce any directional effect.

Description: The drop was initiated from 3000 feet at 65 knots indicated air-speed. Good parachute and wing configuration. Shallow R/H spiral was observed upon wing stabilization. Nose up and differential turn commands did not appear to reduce the spiral condition. Slight trailing edge wing flutter was observed.

Data Test Conditions

Launch wind velocity - 4 knots. SSE

Dummy weight - 265 pounds

Pack configuration - "F" 16 Gusset wing - short keel lines

Bottle capacity - 205 in³ (3400 psi)

Records

Oscillograph data were obtained. See Tables 4, 5, and 6 for data summary.

Remarks: Flight control system was not adequate for directional control sensitivity evaluation.

November 16, 1962

FLIGHT TEST REPORT NO. 88-8G-15

MODEL NO. 149

- Objective:** To demonstrate adequate flight control and to perform linked right and left 360 degree turns.
- Results:** Good deployment to glider configuration. Satisfactory linked right and left turns of 180 degrees was demonstrated.
- Description:** The drop was initiated from 3000 feet at 65 knots indicated air-speed. Satisfactory launch, parachute and wing were established. Stabilized wing was in a slight L/H spiral. Wing responded to nose up trim command to $\alpha = 33^\circ$. Satisfactory differential lateral control response was demonstrated by completing 180 degree turns to the right and left. Flutter was observed on both wing trailing edges until the angle of attack was increased to approximately 35 degrees. Response to flare command was normal.

Data: Test Conditions

Launch wind velocity - 5 knots. WSW

Dummy weight - 265 pounds

Pack configuration - "F" 16 Gusset wing - Short keel lines

Bottle capacity - 205 in³ (3400 psi)

Records

Oscillograph and cinetheodolite data were obtained. See Tables 4, 5, and 6 for data summary.

- Remarks:** Flight control was achieved in increased angle of attack configuration. Higher launch altitudes are required to permit investigation of linked R/H and L/H 360 degree turns.

November 20, 1962

FLIGHT TEST REPORT NO. 89-8G-16

MODEL NO. 149

- Objective:** To obtain data on flight control capability, utilizing differential lateral control.
- Results:** Good deployment with stable glider configuration. Directional control, utilizing the differential lateral input, was unsatisfactory on this flight.
- Description:** The drop was initiated from 4000 feet at 65 knots indicated air-speed. Satisfactory launch, parachute and stable wing were established. Wing response to differential lateral control inputs had little or no effect on the flight path. Increasing the angle of attack (34°) provided more turning capability but no significant change was observed in aircraft response to control inputs. Trailing edge wing flutter was observed and was not entirely eliminated by increasing the angle of attack. The wing did not respond to the flare command.
- Data:** Test Conditions
Surface wind velocity - 9 knots W
Dummy weight - 265 pounds
Pack configuration - "F" 16 Gusset wing - Short keel lines
Bottle capacity - 205 in³ (3400 psi)
- Records
Oscillograph data were obtained. See Table 4 for data summary.
- Remarks:** Upper air gust may have been a contributing factor to the poor control response demonstrated on this flight. The glider landed a mile from the control zone, and it is possible that the flare signal was blocked out by the terrain.

November 21, 1962

FLIGHT TEST REPORT NO. 90-6G-20

MODEL NO. 149

- Objective:** To obtain data on lateral control response with 34 degree angle of attack.
- Results:** Good deployment with stable glider configuration. No directional control response to control inputs.
- Description:** The drop was initiated from 4000 feet at 65 knots indicated air-speed. Satisfactory launch, parachute and stable wing were established. Nose up trim was commanded to establish the test configuration (34° angle of attack). Right and left turns utilizing differential lateral control were commanded but no response was noted. Flare command was not responded to.

Data: Test Conditions

Launch wind velocity - 11 knots. NNE

Dummy weight - 265 pounds

Pack configuration - "F"

Bottle Capacity - 125 in³ (4100 psig)

Records

Oscillograph data were obtained. See Tables 4 and 6 for data summary.

- Remarks:** Post flight inspection revealed:
1. Although there was no vehicle response noted for the differential lateral control inputs, riser length was changed.
 2. Low battery voltage at the control truck probably was the cause of insufficient signal strength to affect flare command.

November 21, 1962

FLIGHT TEST REPORT NO. 91-8G-17

MODEL NO. 149

Objectives: Demonstrate response of wing to command signal inputs at 30 degree angle of attack by first applying single lateral control against original spiral for half of the possible control time (25 seconds) and thereafter applying differential lateral control inputs in opposite directions for 50 seconds.

Results: Good deployment with stable glider configuration. The above stated objectives of this drop were satisfactorily demonstrated.

Description: The drop was initiated from 4000 feet at 65 knots indicated air-speed. Single lateral control was commanded to stabilize the glider. Six changes of direction utilizing differential lateral control were satisfactorily executed throughout the flight. Best response time was 9 seconds with the average response time being approximately 22 seconds. Wing response to the flare command was satisfactory.

Data: Test Conditions

Launch wind velocity - 6 knots N

Dummy weight - 265 pounds

Pack configuration - "F" 16 Gusset wing - Short keel lines

Bottle Capacity - 205 in³ (3400 psig)

Records

Oscillograph and cinetheodolite data were obtained. See Tables 4, 5, and 6 for data summary.

Remarks: This was the last flight on Individual Drop Glider with the instrumented dummy, as well as the last flight of the Test Program under the existing contract.

DISTRIBUTION

U. S. Army Infantry Center	4
U. S. Army Aviation Test Board	2
Aviation Test Office, Edwards AFB	2
Office of Chief of R&D	3
U. S. Army Aviation School	2
US Army Combat Developments Command Quartermaster Agency	2
US Army QM R&E Field Evaluation Agency	1
U. S. Army Combat Developments Command, Transportation Agency	2
U. S. Army Aviation and Surface Materiel Command	2
U. S. Army Transportation Research Command	51
US Army Airborne, Electronics and Special Warfare Board	4
U. S. Army Research & Development Group (Europe)	3
TC Liaison Officer, US Army Aviation School	2
Hq USATDS	2
U. S. Marine Corps Liaison Group	2
Marine Corps Landing Force Development Center	2
U. S. Army Standardization Group, Canada	1
Canadian Army Liaison Officer, U. S. Army Transportation School	1
British Army Staff, British Embassy	4
U. S. Army Standardization Group, U. K.	1
National Aviation Facilities Experimental Center	3
NASA, LRC, Langley Station	6
Manned Spacecraft Center, NASA	2
Flight Test Center, NASA, Edwards AFB	2
Defense Documentation Center	10
U. S. Strike Command	2
U. S. Army Mobility Command	6
U. S. Army Materiel Command	6
U. S. Army Limited War Laboratory	2
USA Combat Developments Engineering Command	1
Advanced Research Projects Agency	4
Tactical Air Command, Langley	4
First Combat Applications Group, Eglin AFB	1

Ryan Aeronautical Company, San Diego, California, FLEXIBLE-WING INDIVIDUAL DROP GLIDER, Final Report. Report No. 62B138A, July, 1963, 158 pp. (Contract DA44-177-TC-827)
TRECUM 63-26 Unclassified Report

1. Flexible-Wing Individual Drop Glider
2. Contract DA 44-177-TC-827

The results of an experimental development and test program of an inflatable flexible-wing individual drop glider is presented. System operation and wing packing procedures are discussed. Aerodynamics, loads, design, stress, weights and test data, such as deployment shock loads and accelerations, glide performance and landing velocities and shock loads, are given.

Ryan Aeronautical Company, San Diego, California, FLEXIBLE-WING INDIVIDUAL DROP GLIDER, Final Report. Report No. 62B138A, July, 1963, 158 pp. (Contract DA44-177-TC-827)
TRECUM 63-26 Unclassified Report

1. Flexible-Wing Individual Drop Glider
2. Contract DA 44-177-TC-827

The results of an experimental development and test program of an inflatable flexible-wing individual drop glider is presented. System operation and wing packing procedures are discussed. Aerodynamics, loads, design, stress, weights and test data, such as deployment shock loads and accelerations, glide performance and landing velocities and shock loads, are given.

Ryan Aeronautical Company, San Diego, California, FLEXIBLE-WING INDIVIDUAL DROP GLIDER, Final Report. Report No. 62B138A, July, 1963, 158 pp. (Contract DA44-177-TC-827)
TRECUM 63-26 Unclassified Report

1. Flexible-Wing Individual Drop Glider
2. Contract DA 44-177-TC-827

The results of an experimental development and test program of an inflatable flexible-wing individual drop glider is presented. System operation and wing packing procedures are discussed. Aerodynamics, loads, design, stress, weights and test data, such as deployment shock loads and accelerations, glide performance and landing velocities and shock loads, are given.

Ryan Aeronautical Company, San Diego, California, FLEXIBLE-WING INDIVIDUAL DROP GLIDER, Final Report. Report No. 62B138A, July, 1963, 158 pp. (Contract DA44-177-TC-827)
TRECUM 63-26 Unclassified Report

1. Flexible-Wing Individual Drop Glider
2. Contract DA 44-177-TC-827

The results of an experimental development and test program of an inflatable flexible-wing individual drop glider is presented. System operation and wing packing procedures are discussed. Aerodynamics, loads, design, stress, weights and test data, such as deployment shock loads and accelerations, glide performance and landing velocities and shock loads, are given.

Ryan Aeronautical Company, San Diego, California, FLEXIBLE-WING INDIVIDUAL DROP GLIDER, Final Report. Report No. 62B138A, July, 1963, 158 pp. (Contract DA44-177-TC-827)
TRECOC 63-26 Unclassified Report

1. Flexible-Wing Individual Drop Glider
2. Contract DA 44-177-TC-827

Ryan Aeronautical Company, San Diego, California, FLEXIBLE-WING INDIVIDUAL DROP GLIDER, Final Report. Report No. 62B138A, July, 1963, 158 pp. (Contract DA44-177-TC-827)
TRECOC 63-26 Unclassified Report

1. Flexible-Wing Individual Drop Glider
2. Contract DA 44-177-TC-827

The results of an experimental development and test program of an inflatable flexible-wing individual drop glider is presented. System operation and wing packing procedures are discussed. Aerodynamics, loads, design, stress, weights and test data, such as deployment shock loads and accelerations, glide performance and landing velocities and shock loads, are given.

The results of an experimental development and test program of an inflatable flexible-wing individual drop glider is presented. System operation and wing packing procedures are discussed. Aerodynamics, loads, design, stress, weights and test data, such as deployment shock loads and accelerations, glide performance and landing velocities and shock loads, are given.

Ryan Aeronautical Company, San Diego, California, FLEXIBLE-WING INDIVIDUAL DROP GLIDER, Final Report. Report No. 62B138A, July, 1963, 158 pp. (Contract DA44-177-TC-827)
TRECOC 63-26 Unclassified Report

1. Flexible-Wing Individual Drop Glider
2. Contract DA 44-177-TC-827

Ryan Aeronautical Company, San Diego, California, FLEXIBLE-WING INDIVIDUAL DROP GLIDER, Final Report. Report No. 62B138A, July, 1963, 158 pp. (Contract DA44-177-TC-827)
TRECOC 63-26 Unclassified Report

1. Flexible-Wing Individual Drop Glider
2. Contract DA 44-177-TC-827

The results of an experimental development and test program of an inflatable flexible-wing individual drop glider is presented. System operation and wing packing procedures are discussed. Aerodynamics, loads, design, stress, weights and test data, such as deployment shock loads and accelerations, glide performance and landing velocities and shock loads, are given.

The results of an experimental development and test program of an inflatable flexible-wing individual drop glider is presented. System operation and wing packing procedures are discussed. Aerodynamics, loads, design, stress, weights and test data, such as deployment shock loads and accelerations, glide performance and landing velocities and shock loads, are given.

Ryan Aeronautical Company, San Diego, California, FLEXIBLE-WING INDIVIDUAL DROP GLIDER, Final Report. Report No. 62B138A, July, 1963, 158 pp. (Contract DA44-177-TC-827)
TRECUM 63-26 Unclassified Report

The results of an experimental development and test program of an inflatable flexible-wing individual drop glider is presented. System operation and wing packing procedures are discussed. Aerodynamics, loads, design, stress, weights and test data, such as deployment shock loads and accelerations, glide performance and landing velocities and shock loads, are given.

Ryan Aeronautical Company, San Diego, California, FLEXIBLE-WING INDIVIDUAL DROP GLIDER, Final Report. Report No. 62B138A, July, 1963. 158 pp. (Contract DA44-177-TC-827)
TRECUM 63-26 Unclassified Report

The results of an experimental development and test program of an inflatable flexible-wing individual drop glider is presented. System operation and wing packing procedures are discussed. Aerodynamics, loads, design, stress, weights and test data, such as deployment shock loads and accelerations, glide performance and landing velocities and shock loads, are given.

1. Flexible-Wing Individual Drop Glider
2. Contract DA 44-177-TC-827

Ryan Aeronautical Company, San Diego, California, FLEXIBLE-WING INDIVIDUAL DROP GLIDER, Final Report. Report No. 62B138A, July, 1963, 158 pp. (Contract DA44-177-TC-827)
TRECUM 63-26 Unclassified Report

The results of an experimental development and test program of an inflatable flexible-wing individual drop glider is presented. System operation and wing packing procedures are discussed. Aerodynamics, loads, design, stress, weights and test data, such as deployment shock loads and accelerations, glide performance and landing velocities and shock loads, are given.

Ryan Aeronautical Company, San Diego, California, FLEXIBLE-WING INDIVIDUAL DROP GLIDER, Final Report. Report No. 62B138A, July, 1963, 158 pp. (Contract DA44-177-TC-827)
TRECUM 63-26 Unclassified Report

The results of an experimental development and test program of an inflatable flexible-wing individual drop glider is presented. System operation and wing packing procedures are discussed. Aerodynamics, loads, design, stress, weights and test data, such as deployment shock loads and accelerations, glide performance and landing velocities and shock loads, are given.

1. Flexible-Wing Individual Drop Glider
2. Contract DA 44-177-TC-827

1. Flexible-Wing Individual Drop Glider
2. Contract DA 44-177-TC-827

Ryan Aeronautical Company, San Diego, California, FLEXIBLE-WING INDIVIDUAL DROP GLIDER, Final Report. Report No. 62B138A, July, 1963, 158 pp. (Contract DA44-177-TC-827) TRECOM 63-26 Unclassified Report

1. Flexible-Wing Individual Drop Glider
2. Contract DA 44-177-TC-827

The results of an experimental development and test program of an inflatable flexible-wing individual drop glider is presented. System operation and wing packing procedures are discussed. Aerodynamics, loads, design, stress, weights and test data, such as deployment shock loads and accelerations, glide performance and landing velocities and shock loads, are given.

Ryan Aeronautical Company, San Diego, California, FLEXIBLE-WING INDIVIDUAL DROP GLIDER, Final Report. Report No. 62B138A, July, 1963, 158 pp. (Contract DA44-177-TC-827) TRECOM 63-26 Unclassified Report

1. Flexible-Wing Individual Drop Glider
2. Contract DA 44-177-TC-827

The results of an experimental development and test program of an inflatable flexible-wing individual drop glider is presented. System operation and wing packing procedures are discussed. Aerodynamics, loads, design, stress, weights and test data, such as deployment shock loads and accelerations, glide performance and landing velocities and shock loads, are given.

Ryan Aeronautical Company, San Diego, California, FLEXIBLE-WING INDIVIDUAL DROP GLIDER, Final Report. Report No. 62B138A, July, 1963, 158 pp. (Contract DA44-177-TC-827) TRECOM 63-26 Unclassified Report

1. Flexible-Wing Individual Drop Glider
2. Contract DA 44-177-TC-827

The results of an experimental development and test program of an inflatable flexible-wing individual drop glider is presented. System operation and wing packing procedures are discussed. Aerodynamics, loads, design, stress, weights and test data, such as deployment shock loads and accelerations, glide performance and landing velocities and shock loads, are given.

Ryan Aeronautical Company, San Diego, California, FLEXIBLE-WING INDIVIDUAL DROP GLIDER, Final Report. Report No. 62B138A, July, 1963, 158 pp. (Contract DA44-177-TC-827) TRECOM 63-26 Unclassified Report

1. Flexible-Wing Individual Drop Glider
2. Contract DA 44-177-TC-827

The results of an experimental development and test program of an inflatable flexible-wing individual drop glider is presented. System operation and wing packing procedures are discussed. Aerodynamics, loads, design, stress, weights and test data, such as deployment shock loads and accelerations, glide performance and landing velocities and shock loads, are given.

UNCLASSIFIED

UNCLASSIFIED