

UNCLASSIFIED

DOCUMENTATION CENTER
FOR
TECHNICAL INFORMATION
ALEXANDRIA, VIRGINIA



UNCLASSIFIED

NOTICE: When government or other drawings, specifications or other data are used for any purpose other than in connection with a definitely related government procurement operation, the U. S. Government thereby incurs no responsibility, nor any obligation whatsoever; and the fact that the Government may have formulated, furnished, or in any way supplied the said drawings, specifications, or other data is not to be regarded by implication or otherwise as in any manner licensing the holder or any other person or corporation, or conveying any rights or permission to manufacture, use or sell any patented invention that may in any way be related thereto.

August 12, 1963

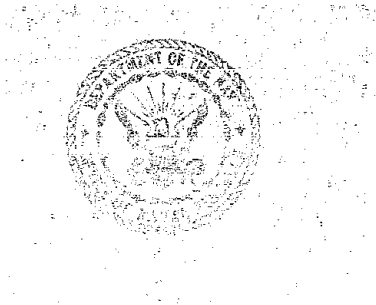

CONTENTS

Abstract	1
Problem Status	1
Authorization	1
INTRODUCTION	1
PREVIOUS UNITS	3
Description	3
Results	6
EXPERIMENTAL TECHNIQUES	6
Design of New Six-Lamp Unit	6
Constant-Dilution Technique	7
Measurement of Gas-Flow Rate	8
Gas-Sampling Technique	8
Light-Intensity Measurements	9
Growth Measurements	9
Gas Analyzers	9
Culture Medium	9
Test Organism	9
RESULTS	9
Effect of Rate of Carbon Dioxide Input on Oxygen Production	9
Combined Effects of Rate of Carbon Dioxide Input and Light Intensity	11
Effect of Stirring Rate	12
Effect of Urea Concentration in Culture Medium	12
Oxygen Production as a Function of Light Intensity and Electrical Energy	13
DISCUSSION	13
Volume Requirement of an Algal System	13
Sticking and Settling of Cells	14
Electrical Power Considerations	14
Other Light Sources	15
Foaming	15
Uniformity During a Given Run	15
Reproducibility from One Run to Another	16
Photosynthetic Quotients	16
Gas Exchange as a Criterion of Steady-State Conditions	17
A Critical Look	18
SUMMARY	19
FUTURE PLANS	19
ACKNOWLEDGMENTS	20
REFERENCES	20
APPENDIX A—Burk's Medium	21

A Study of the Feasibility of Oxygen Production by Algae for Nuclear Submarines

P. J. HANNAN, R.L. SHULER, AND C. PATOUILLET

*Organic and Biological Chemistry Branch
Chemistry Division*

The mass culture of algae has been considered as a means of removing carbon dioxide and replenishing oxygen in the atmosphere of a nuclear submarine. For the past 2-1/2 years the feasibility of this method has been investigated in the laboratory by measuring the growth rate and the oxygen production of the Sorokin strain of *Chlorella pyrenoidosa* under various conditions of culture.

The results obtained with a small pilot plant containing 6200 ml of algal suspension have been evaluated; the effects of light intensity, rate of stirring, rate of carbon dioxide supply, and other variables were part of this study. Light energy was supplied by six 1500-watt incandescent lamps which extended through the suspension and were encased in 50-mm O.D. cooling jackets. When the light intensity at the surface of these jackets was 34,000 foot-candles (the limit with the equipment at hand), the oxygen production was 4500 cc per hour.

Oxygen production increases with light intensity, but the oxygen produced per watt of electrical energy expended is constant over a wide range of light intensities. The amount of electrical energy required to provide enough oxygen for one man is between 30 and 50 kw, depending on the design of the gas exchanger. This high requirement makes the process prohibitive at present, but the development of more efficient high-intensity light sources could change the outlook.

The dependability of the algal system in providing a constant supply of oxygen has been assured by this study; also, the volume requirements of the algal system are competitive with existing systems for carbon dioxide removal and oxygen production.

INTRODUCTION

The extended-submergence capability of a nuclear submarine depends greatly on the maintenance of a habitable atmosphere, one in which carbon dioxide is limited to a maximum of 1 percent concentration, oxygen is maintained at its normal level, and contaminants such as cooking and body odors are efficiently removed. Primarily because of the continued efforts of the U.S. Naval Research Laboratory, techniques are available for the maintenance of pure atmospheres in today's ships; however, a multiplicity of devices is required.

It has been well-known, of course, that algae can remove carbon dioxide, produce fresh oxygen, and also scrub out certain contaminants from an air stream. These considerations prompted the current investigation to determine the feasibility of an algal system in maintaining the necessary balance in a submarine. Factors of primary importance were the size of the unit necessary to accomplish the task, the power requirements of the artificial illumination, and the reliability of the system. Also to be considered were the gaseous byproducts of algal growth, the tolerance of the algae to exotic contaminants such as hydrocarbon

vapors and cigarette smoke, and the ease of operation of the unit.

An estimate of the power requirement for the algal system was made by Leonard (1) in 1958. Basing his calculations on algal growth rates recorded in the literature, reported quantum requirements, and electrical efficiencies of light sources, he concluded that the power required was within the limits of the nuclear submarine's potential. Early in 1960, research on the growth of algae was begun at NRL, and much of the preliminary work concerned the measurement of growth as a function of light intensity, suspension density, depth of suspension through which the light passed, and rate of stirring of the suspension; the results of these investigations and some preliminary pilot-plant studies are described in a report issued previously (2). The experience gained in these studies prompted the construction of the small pilot plant which forms the basis of this report (Fig. 1). In this unit provision is made for the simultaneous determination of suspension density, carbon dioxide absorption, and oxygen production. The necessary light energy is supplied by six $3/8 \times 10$ in. incandescent General Electric Quartz-line lamps having the characteristics shown in Figs. 2 and 3. These lamps contain tungsten filaments in quartz envelopes, and their life expectancy is 2000 hours when operated at the peak voltage (277 v).

NRL Problem C08-32; Project SP 89422. This is an interim report; work is continuing on the problem.

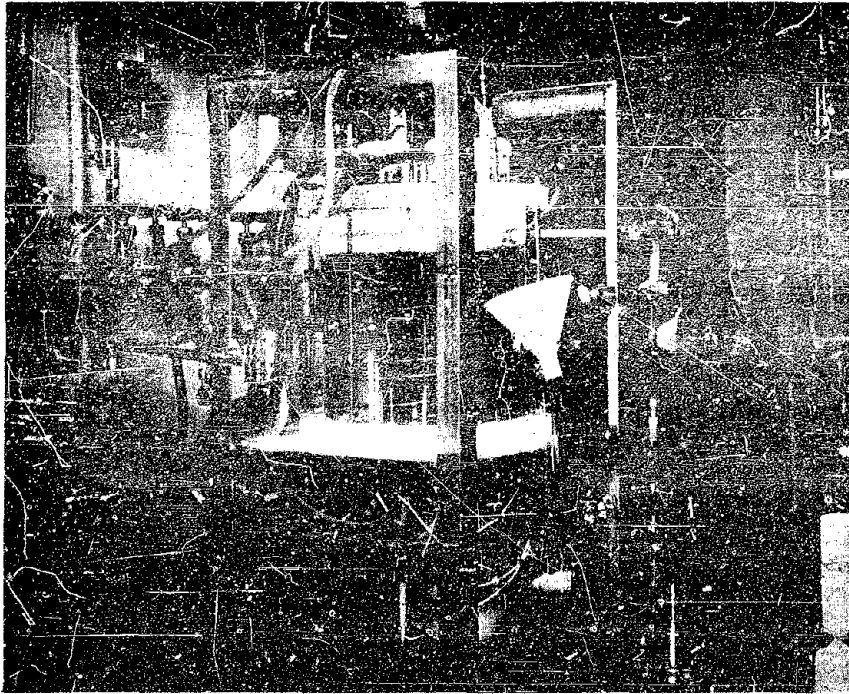

Fig. 1 - Algal gas exchanger used in this study

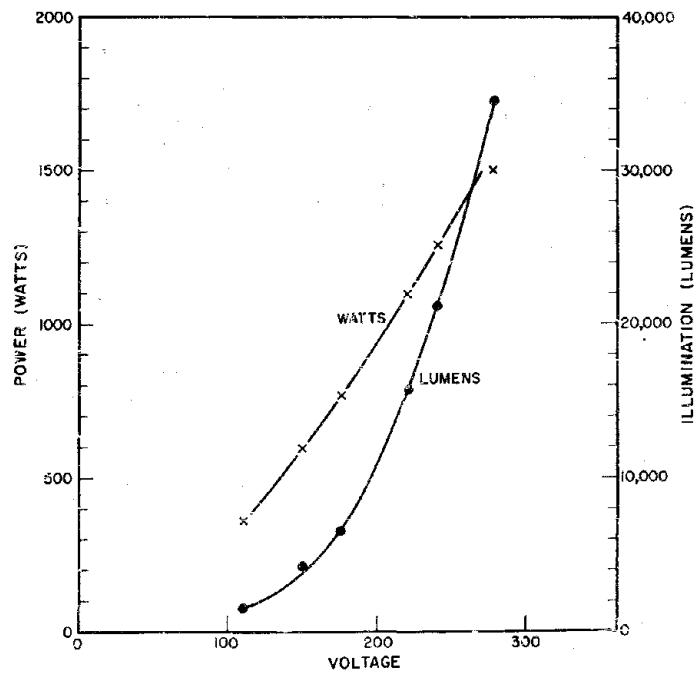

Fig. 2 - Light production and power requirements as functions of voltage on Quartzline lamps

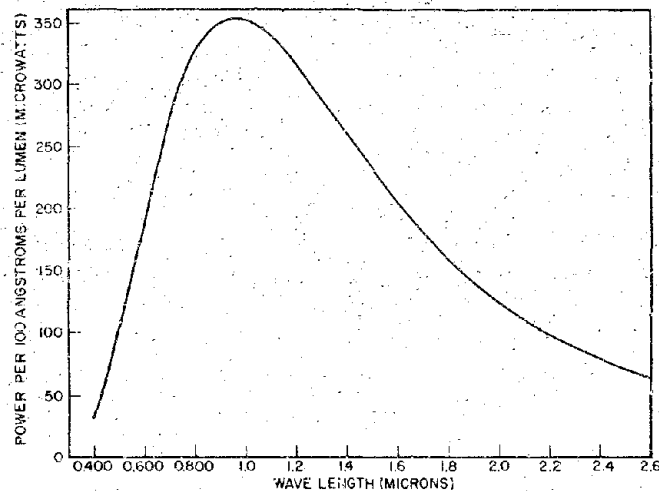

Fig. 3 - Light energy as a function of wave length produced by Quartzline lamps (data by General Electric Co.)

PREVIOUS UNITS

Description

A brief look at the small pilot plants constructed and evaluated previously will serve to emphasize some of the necessary design characteristics of an efficient gas exchanger and, perhaps more important, point out the features which must be avoided. The first unit, tested in 1960 (Fig. 4), consisted of three concentric glass tubes 4 ft long, surrounding a fluorescent tube. One annular space contained the algal suspension, and the other contained temperature-controlled water. The most serious deficiency of this design was that the rise of inlet gas bubbles through the tube had a flotation effect which removed the algae from the body of the suspension and deposited the cells in a dense ring near the top.

The purpose of the second unit, also constructed in 1960 (Figs. 5, 6), was to provide a gas exchanger with some research adaptability. It consisted of a reservoir of suspension and a circulating pump connected to a series of glass tubes fastened together with rubber tubing. Lighting was supplied by banks of fluorescent lamps placed above and below the trays containing the tubing. The purpose of the design was to make possible the illumination of varying depths of suspension simply by using tubes of different diameters. An increase in the light path, determined in this case by the diameter

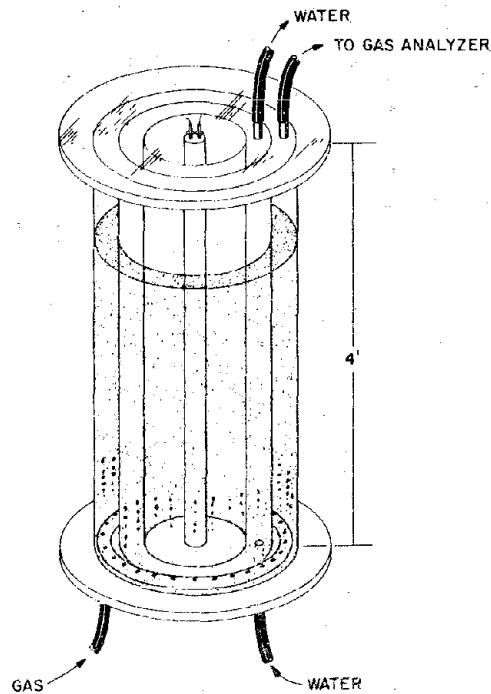

Fig. 4 - Schematic drawing of first gas exchanger, fluorescent-lighted

of the tubes, has an adverse effect on the growth rate for several reasons; the intensity of the light decreases with distance, and the mutual shading effect of the cells becomes more pronounced.

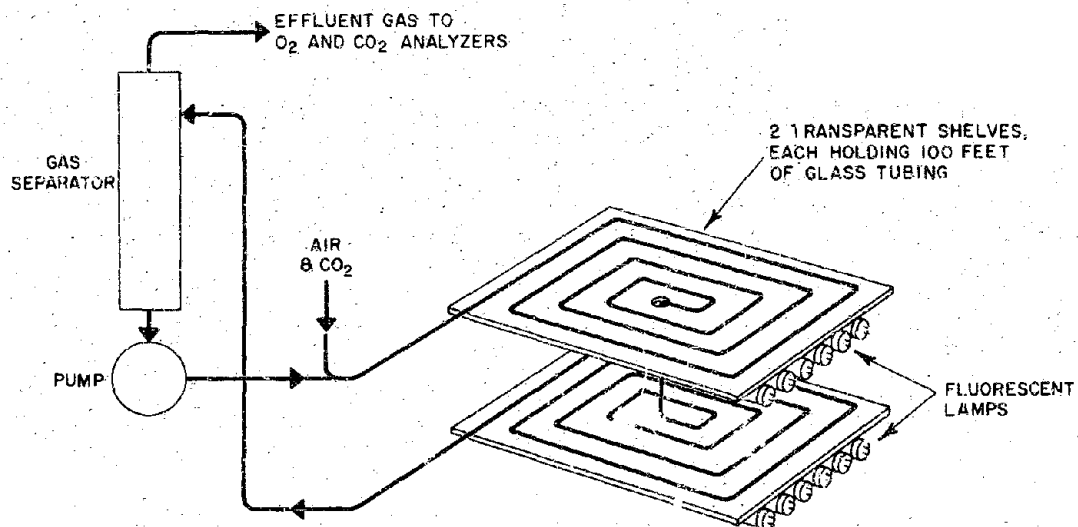

Fig. 5 - Schematic drawing of tube-type gas exchanger

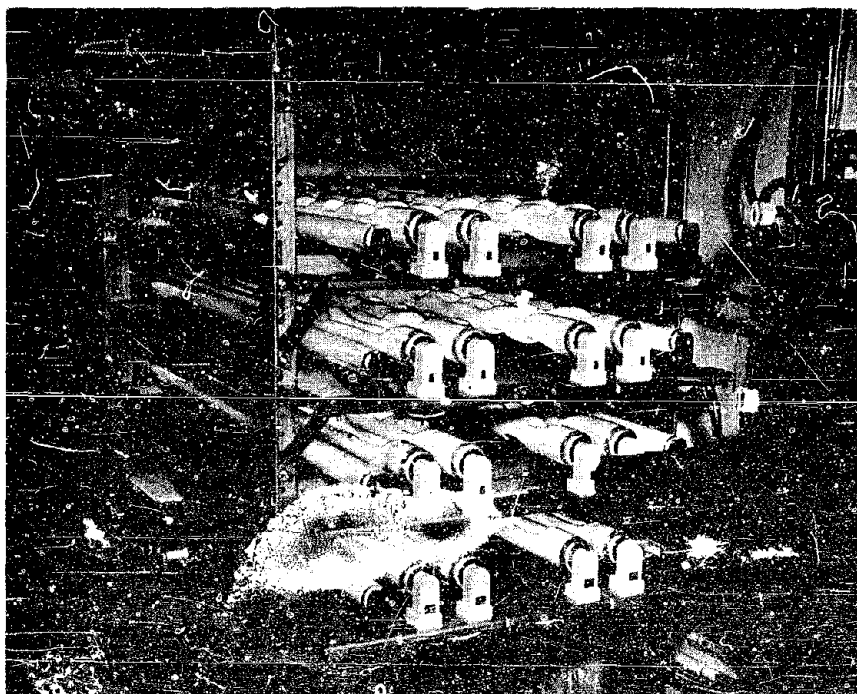

Fig. 6 - Photograph of lighted portion of tube-type gas exchanger

Two difficulties beset this plan: (a) it was too time-consuming to change from one set of tubes to another because of the multiple connections necessary, and (b) the flow rate of suspension could not be increased sufficiently to prevent the algae cells from sticking to the tubes. Each bubble of gas (5 percent CO₂-in-air) was exposed to the suspension for approximately two minutes, and by the time it was released into the overflow chamber it was CO₂-free. The results of subsequent experiments have shown that the oxygen production of this unit was severely limited by this effect.

The first unit to be equipped with the high-intensity incandescent lamps described previously

is shown in Fig. 7. The schematic representation of this unit in Fig. 8 shows the light path in any direction to be a minimum two inches, with two inches from the glass cooling jackets to the walls, bottom, and top of the suspension, and four inches between light jackets. Circulation was provided by a pump which drew the suspension from the four corners of the tank and emptied it back into the center. Experience showed two glaring deficiencies of this unit: (a) the circulation system was not adequate, and many cells settled to the bottom, and consequently (b) the productivity of the unit was low. The main reason for the limited oxygen production was the large distance between the

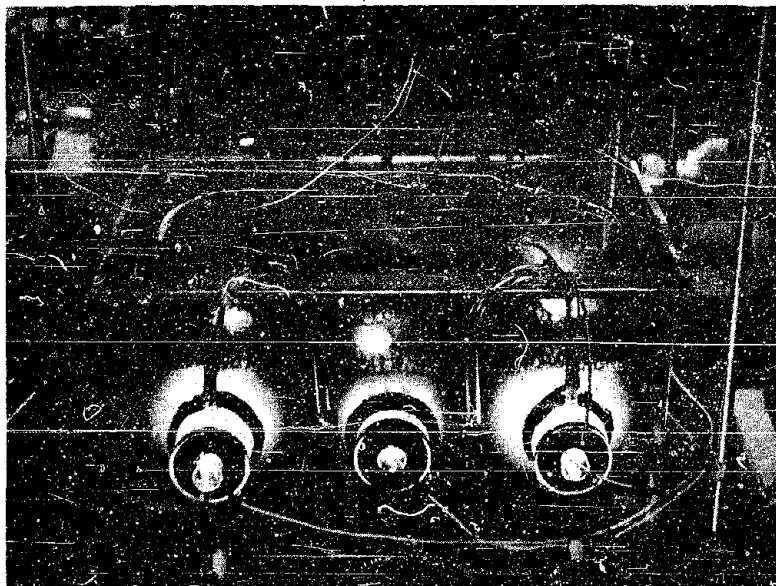

Fig. 7 - Photograph of gas exchanger containing three Quartzline lamps

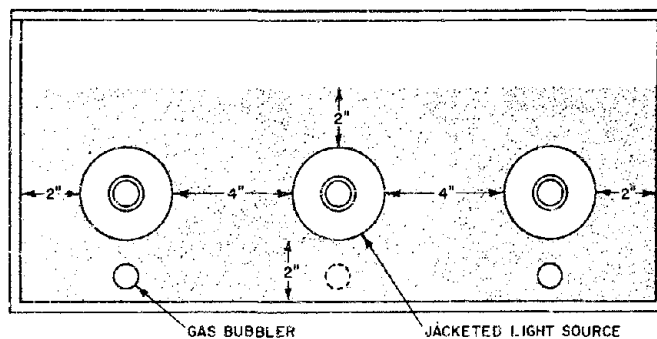

Fig. 8 - Schematic drawing of three-lamp gas exchanger

lights. It had been thought that a 2-in. light path, with its large proportion of relatively dark areas, would permit the use of high light intensities without solarization* of the cells.

The first unit designed to afford the simultaneous measurement of growth and gas exchange is shown in Fig. 9. It will be the subject of a separate report; it is sufficient to say here, however, that it consisted of two annular spaces around a high-intensity light, the outer one containing the algal suspension and the inner temperature-controlled water. Stirring was provided by a circulating pump which drew suspension from the bottom and forced it through three plastic tubes extending into the suspension to give the entire suspension a swirling motion. Settling of the cells was not a problem, and measurements of the inlet and exit

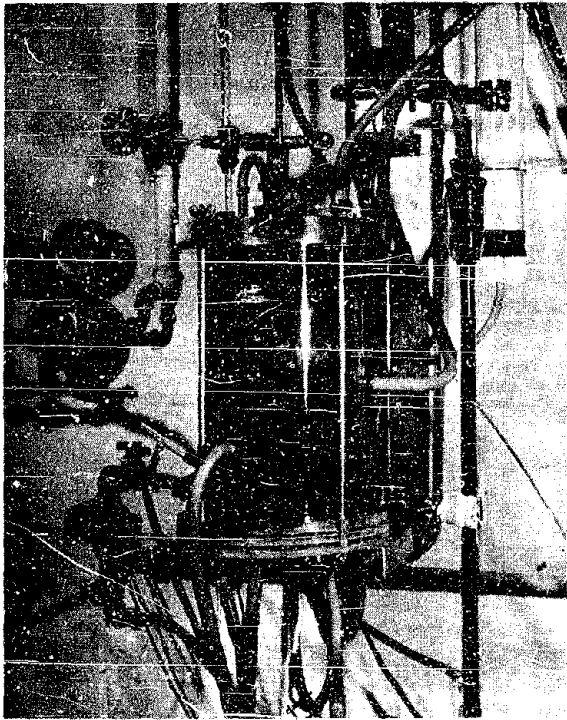

Fig. 9 - Photograph of gas exchanger containing one Quartzline lamp, and with a light path of 0.75 in.

*This is a term used to denote injury of the cells by exposure to light of too great intensity. The physiological basis for the solarization effect is not known, but some investigators feel that it is caused by a momentary deficiency of required nutrients in the presence of excess light quanta.

gases for carbon dioxide and oxygen were conveniently obtained. The one difficulty with this unit was the tendency of the cells to stick to the walls of the cylinder; these surfaces are made of Lucite, which seems to have a greater affinity for cells than glass. The annular space containing the suspension in this unit was 0.75 in.

Results

To compare the performances of these units, the light path and the oxygen production of each are listed in Table I. The data given do not represent all the information gained, but they serve as good background material for the appraisal of the six-lamp unit which is the subject of this report.

TABLE I
Oxygen Production by Previous Units

Unit	Light Path (in.)	Light Intensity (ft-candles)	Maximum Oxygen Production
Four-foot exchanger (Fig. 4)	1	—	Gas-exchange measurements not made
Tube-type exchanger (Figs. 5,6)	0.375	500	250 ml/hr/liter suspension*
Three-lamp exchanger (Figs. 7,8)	2	15,000	50 ml/hr/liter suspension
One-lamp exchanger (Fig. 9)	0.750	12,500	315 ml/hr/liter suspension

*All volumes in this report were measured at ambient temperature.

EXPERIMENTAL TECHNIQUES

Design of New Six-Lamp Unit

The six-lamp unit (Fig. 10) was designed to provide both intense illumination for the cells and rapid stirring. Two purposes are served by the turbulence achieved in rapid stirring: (a) the cells are prevented from settling to the bottom or sticking to the walls, and (b) their exposure to the light

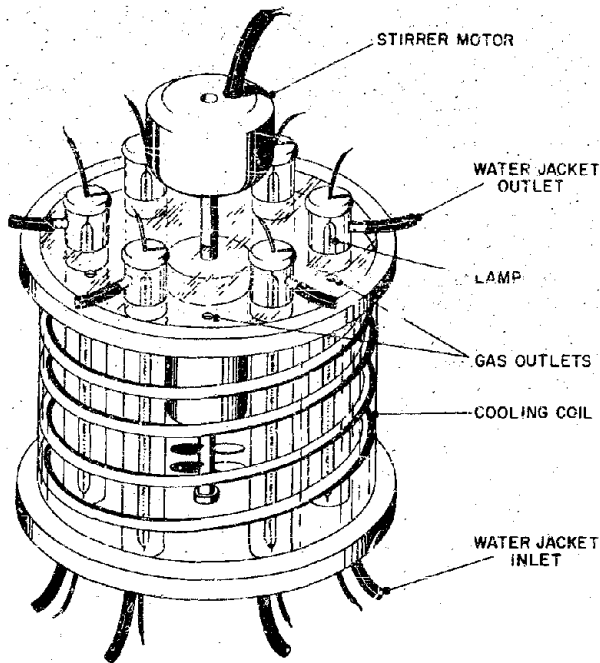

Fig. 10 - Schematic drawing of six-lamp gas exchanger

source is of short duration; consequently, high light intensities can be used. Other features provided in this unit are a dependable constant-dilution device and a simple gas-sampling system for the continuous analysis of the exit gas for carbon dioxide and oxygen content.

The unit consists of a glass cylinder 10 in. O.D. and 10 in. high which is held by O-ring seals in grooved Lucite base plates. Six high-intensity lamps are placed vertically through the cylinder in cooling jackets (50-mm O.D.) which extend through O-ring seals in the bottom plate. The distance between light jackets is 1.25 in., and the distance from the light-jacket surface to the wall of the cylinder is 0.50 in. Through the center of the entire unit, and positioned by a Teflon bushing in a stainless steel assembly, is a 5/8-in. steel shaft which is rotated by a variable-speed 1/3-hp dc motor. Two 3-in. propellers at the bottom of this shaft provide most of the circulation, but some additional turbulence is provided by a Lucite collar, 3-in. diameter, which fits onto the shaft above the propellers and serves to exclude the algae cells from the generally dark region in the center. The

light jackets opposite each other, through the center of the unit, are 4 in. apart, and cells occupying this area would not receive sufficient light for growth. With the normal rate of stirring, the volume of suspension contained in the unit is 6200 ml.

The CO₂-air mixtures are provided by the method described in a previous report (2); the gas is forced into the suspension through two fritted glass spargers in the base of the unit. The rotation of the propellers is such that the suspension is forced downward and across the gas inlets, thereby carrying the bubbles outward and then upward through the suspension. Temperature equilibrium is maintained by two complementary systems, the first a preset flow of cooling water through the jackets surrounding the lights, and the second a thermoregulator which activates a solenoid valve permitting cooling water to flow through the stainless steel coil within the cylinder. Temperature is easily maintained within $\pm 0.2^\circ\text{C}$.

Constant-Dilution Technique

Rather than attempt to maintain a fixed suspension density in the culture vessel, as in most investigations of this type, the practice in this set of experiments has been to establish a set dilution rate and allow the culture to establish an equilibrium density. For this reason the suspension density in these studies cannot be regarded as a primary variable; however, past experience has shown that oxygen production is so much more a function of light intensity than suspension density that little has been sacrificed by using this method.

The principle of the constant-dilution device is based on the use of a siphon to draw filtered medium from a constant-pressure head above the supply tank. As illustrated in Fig. 11, a centrifugal pump circulates culture medium from an outlet near the bottom of the supply tank through a glass wool filter which empties into a 1 x 15 in. test tube. A hole in the side of this test tube allows excess liquid to flow back into the tank; this defines the constant head which forces liquid to flow through a siphon into a stainless steel valve and ultimately into the culture vessel. The glass wool filter is changed weekly; otherwise the system requires only cursory checking once a day. The constancy of the system is shown by the results of a five-day run, during which the average flow of

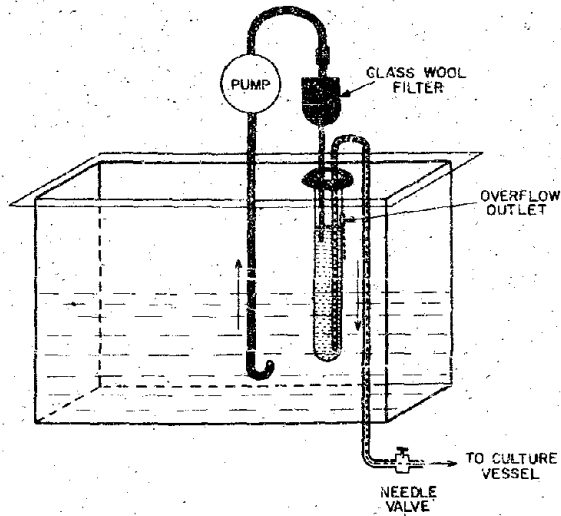

Fig. 11 - Diagram of constant-dilution device

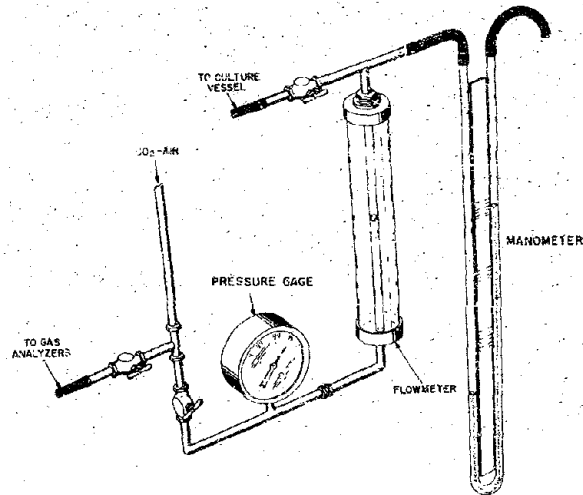

Fig. 12 - Diagram of equipment for measuring gas-flow rates

medium each day ranged from a low of 950 ml to a high of 969 ml per hour. The unit was unattended for 16 hours out of each 24 during this time.

Measurement of Gas Flow Rate

It is essential that the gas flow be maintained at a constant rate and known accurately for the computation of the hourly oxygen production and carbon dioxide absorption rates. The apparatus used is shown in Fig. 12. The inlet gas is conducted through two stopcocks, the pressure between these points being maintained at 5 lb on the gauge, or 1025 mm Hg total on the manometer. The flow system was calibrated by measuring the time necessary to displace known gas volumes through a wet test meter, at various positions of the float in the meter. This system permits the accurate measurement of gas flows regardless of changes in the back pressure of the gas spargers, because the pressure established between the stopcocks, and the flowmeter reading, define the flow rate.

Mixtures of constant CO₂-air composition are obtained by procedures described in the first report on this subject (2). Sampling of the gas for analysis purposes is conveniently provided by allowing a steady flow of approximately 200 ml per minute through a T-joint and stopcock. Since

the setting of this stopcock is never disturbed, there is no effect on the gas flow through the area in which the flow measurements are made. By an independent method of measurement, gas-flow rates at various settings of the flowmeter agreed within 2 percent, and the constancy of flow at a given setting was shown to be within 1 percent.

Gas-Sampling Technique

After passing through the algal suspension, the CO₂-air mixture is allowed to pass freely through several ports in the top of the unit. A small aquarium pump is used to sample the effluent gas at a rate of 400 to 500 cc per minute (compared with the minimum input rate of 2150 cc per minute), and this sample is passed through several drying columns before admittance to the oxygen and carbon dioxide analyzers. The arrangement shown in Fig. 13 provides a smooth flow of effluent gas from the pump to the gas analyzers.

The change in oxygen percentage, before and after passage through the algal suspension, multiplied by the flow rate of gas is computed as the oxygen yield. This method entails a slight error, because it assumes the same volume of gas emerging as entering, but the magnitude of the error is not sufficient to affect the results.

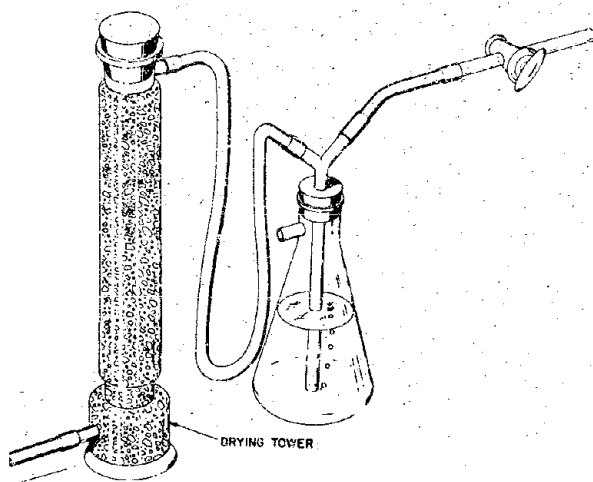

Fig. 13 - Diagram of apparatus providing smooth flow of effluent gas to analyzer

Light-Intensity Measurements

The brightness of the lamps is adjustable by a voltage regulator.* Prior to the assembly of the unit, one of the lamps was placed inside a 50-mm cooling jacket, and the light intensity at the jacket surface was measured at different applied voltages by a G.E. light meter fitted with neutral density filters. All the intensities referred to in this report are those at the surface of the cooling jacket.

Growth Measurements

The density of the culture is determined by diluting a 1-ml sample to 10 ml and measuring the light transmission in a Klett colorimeter fitted with a red filter. Suspension densities are calculated from a standard curve relating colorimeter readings to packed cell volumes. In the range of densities used thus far, the curve is practically linear.

Gas Analyzers

A CO₂ analyzer† based on infrared absorption has been used throughout these experiments. Full-scale reading is 2 percent by volume. The instrument is zeroed one or more times a day, then standardized with a mixture of CO₂-in-air supplied by the Southern Oxygen Company. This gas mix-

ture was analyzed independently with a Haldane apparatus.

The paramagnetic property of oxygen provides the means for its analysis by the instrument‡ used in these studies. Two oxygen percentage ranges are available, 0 to 25 percent and 20 to 25 percent, but only the latter has been used. Dry nitrogen is used to zero the instrument, and dry air is used as the standard.

The input and effluent gases are passed through these analyzers consecutively at a rate of approximately 200 ml per minute. Small changes in the rate of flow do not affect the readings.

Culture Medium

The medium used in these studies is essentially that of Burk, the only modification being the concentration of urea. The composition of Burk's medium is shown in Appendix A; unless otherwise noted, the medium used contained twice the quantity of urea (2X) as is found in Burk's medium. This procedure was adopted to minimize the possibility of a deficiency of the nitrogen source, since its rate of uptake is faster than that of the other nutrients.

Test Organism

Throughout all of these tests the organism used has been the Sorokin strain of *Chlorella pyrenoidosa*, 7-11-05. It is a unicellular alga with a temperature optimum of 37° to 39°C and is known as the fastest-growing organism of its type.

No attempt has been made to exclude bacterial and fungal contaminants from the cultures. Two reasons account for this practice: (a) it is generally agreed that such contaminants have little effect on the algae, and (b) the adoption of sterile-culture techniques aboard a submarine would pose formidable difficulties. It was decided, therefore, to determine the performance of the algal unit without such precautions being taken.

RESULTS

Effect of Rate of Carbon Dioxide Input on Oxygen Production

During the early gas-exchange studies with this unit, there appeared to be a correlation, at a given

*Superior Electric Co., Bristol, Conn.; Powerstat Model 1256C.

†Model 300, Mine Safety Appliances, Pittsburgh, Pa.

‡Model F-3, Beckman Instruments, Pasadena, Cal.

TABLE 2
Effect of Rate of Carbon Dioxide Supply on Oxygen Production

Experiment No.	Gas Flow (cc/min)	CO ₂ Concentration (percent)		CO ₂ Input Rate (cc/hr)†	Oxygen Production		Suspension Density (percent)
		Input	Exit		Volume (cc/hr)†	Standard Deviation	
1*	2150	1.79	0.25	2310	2080	53.5	0.79
2	2750	1.76	0.46	2900	2263	17.5	0.94
3	3600	.77	0.69	3820	2450	35.2	1.00
4	3600	1.55	0.54	3340	2355	0	0.96
5	3600	1.40	0.41	3020	2242	15.2	0.94

*Results obtained on the afternoon of the first day when the system, particularly the suspension density, was probably not at steady state.

†Volumes calculated at ambient temperature.

light intensity, between the oxygen production per hour and the percentage of carbon dioxide remaining in the gas stream after passage through the suspension. Prior to this, a residue of several tenths of a percent CO₂ in the effluent gas was regarded as evidence of an excess supply.

In order to determine the relevance of this observation, a week-long experiment was performed in which constant light intensity and constant dilution rate were maintained, but in which the rate of CO₂ input was changed. The change was effected in two ways, namely, at constant flow rate by adjusting the CO₂ concentration of the gas, and at constant concentration by adjusting the flow rate. In this way any effect on growth as a result of the varied flow rates could be detected. The input and effluent gases were analyzed hourly each day for five days, constant conditions being maintained from noon of one day until noon the next. The results shown in Table 2 are the averages of the analyses for each morning when the unit, after operating for almost 24 hours under constant conditions, was in a steady-state condition. During this test the light intensity was 9000 foot-candles and the dilution rate was 13.2 percent per hour.

The results of this experiment are shown in detail in Table 2, and a plot of oxygen production versus both rate of CO₂ supply and percent CO₂ in the effluent gas is shown in Fig. 14. This graph shows a good correlation with each basis, although the rate of CO₂ supply must be considered as the primary variable.

Several observations should be made on the data in Table 2. The first is the correlation between the steady-state suspension density and oxygen production. Experience has shown that oxygen pro-

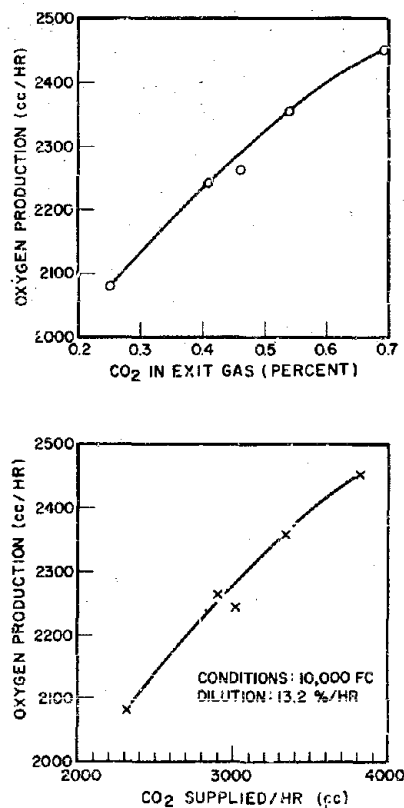

Fig. 14 - Correlation of oxygen production with percent CO₂ in exit gas, and with rate of CO₂ supplied.

duction is independent of suspension density over a wide range of densities; however, oxygen production results from growth, and under the constant-dilution conditions of this experiment

the suspension density rises and falls with the oxygen production. In experiment 1, however, the density was probably not at its equilibrium position because not enough time had elapsed, although the oxygen production was sufficiently constant to warrant its inclusion in the table. The other point worthy of mention is the agreement between experiments 2 and 5, in which different CO_2 concentrations and different gas-flow rates were used, but in which the rate of CO_2 input was essentially the same. The oxygen production values agree well, and so do the CO_2 concentrations in the effluent gas (the difference between 0.41 and 0.46 percent is two divisions on a scale of one hundred on the CO_2 analyzer).

Combined Effects of Rate of Carbon Dioxide Input and Light Intensity

The study just described was extended to include two higher light intensities, 18,000 and 23,000 foot-candles (Fig. 15). In order to complete this study with one continuously cultured suspension during the course of a week, it was necessary to forego the determination of steady-state suspension densities for each set of conditions. When the system had become stabilized so far as gas exchange was concerned, new conditions were estab-

lished for the next part of the study. The establishment of steady-state suspension densities usually requires more time, particularly if the change in growth rate is great (such as that occasioned by a large increase in light intensity).

Eventually a wide range of CO_2 -supply rates was investigated with two higher light intensities. The results of this study are included in Fig. 15. These data represent experiments made over a several-month period and, outside of the curve representing the highest light intensity, the points on each curve are taken from different experiments.

The significance of these data on the design of efficient gas exchangers should be noted here; if high light intensities are to be used, such as those envisaged for submarine use, a high rate of CO_2 input should be used to reach the full potential of the gas exchanger, but if low light intensities are used (*e.g.*, fluorescent lighting in a space ship) there is less need for this high CO_2 input.

In order to provide the higher CO_2 flow rates, it was necessary to use gas streams containing more than 2 percent CO_2 , the maximum amount determined by the CO_2 analyzer. An estimate of the concentrations in these cases was obtained by diluting the input gas with an equal volume of dry nitrogen and determining the reading of the

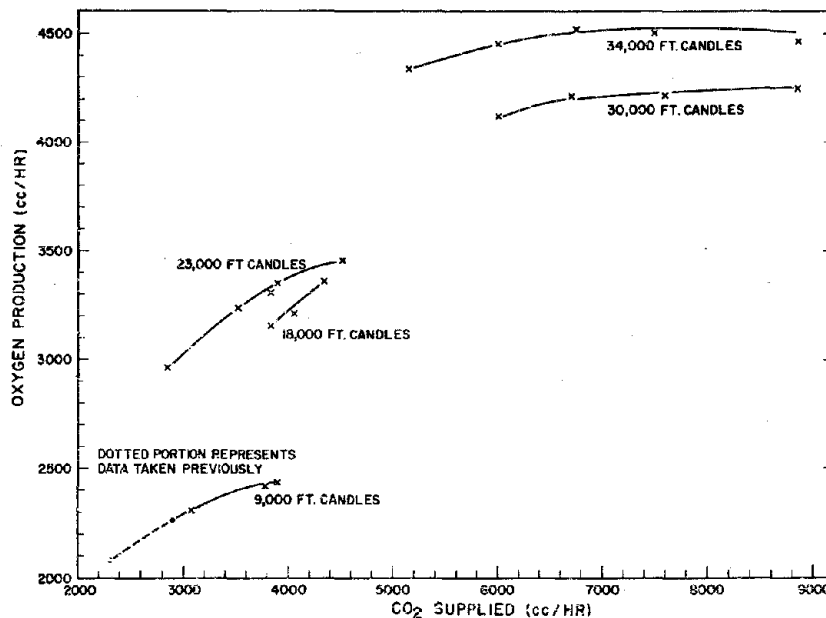

Fig. 15 - Oxygen production as a function of rate of CO_2 input and light intensity

meter. The values thus obtained were sufficiently accurate for the computation of the rate of CO₂ supplied, but not accurate enough to allow the determination, by difference before and after passage through the unit, of the amount absorbed.

Effect of Stirring Rate

In test-tube experiments, which did not include gas-exchange studies, there was an increase in density of suspensions which were stirred rapidly compared with those in which gas bubbles provided the only turbulence (2). Similar beneficial results were noted by Davis *et al.* (3), and by other investigators. At the time the six-lamp unit used in the studies reported here was designed, provision was made for variations in the stirring speed. The 1/3-hp motor was connected to a voltage divider and, for all the experiments except the one described here, the speed was maintained at a constant value.

At a time when the unit had been operating uniformly for 13 hours, the speed of the stirring motor was increased from its normal rotation of 1450 rpm to 2450 rpm; this caused an almost immediate expulsion of a significant proportion of the suspension through the overflow tube. Gas-exchange measurements showed a consequent decrease in oxygen production from 3624 to 3360 cc per hour. However, on the basis of oxygen evolution per liter of suspension, the additional stirring provided an increase from 585 to 680 cc per hour. In a given system, therefore, it is advisable to determine the optimum stirring rate in order to realize the full potential of the unit.

Effect of Urea Concentration in Culture Medium

A choice of several nitrogen sources compatible with algae is possible. However, urea was used in

these experiments because the pH of the medium is unaffected by changes in the concentration of urea (with KNO₃ the pH is gradually raised as growth proceeds).

As stated earlier, during all the experiments described in this report the urea content of the culture medium was twice that specified in Burk's medium. However, there appeared to be a possibility of a urea deficiency during some of the experiments with higher light intensities (based on reported data of the cell composition, the CO₂ absorbed should have required about 90 percent of the urea being supplied the suspension). Therefore when a steady state had been established with the 2X urea medium, the concentration of urea in the supply tank was doubled and enough solid urea was added to the suspension itself to raise the concentration to the level of that in the supply tank. After 2-1/2 days of continuous culture under these conditions, the oxygen production and the suspension density had reached a steady state. The results shown in Table 3 give a comparison of the performance of the unit under the two culture conditions.

While the differences in oxygen production are slight, they are regarded as significant because the oxygen production rarely exceeded 3505 cc per hour. At the time this experiment was conducted, the full significance of the CO₂-supply rate on oxygen production was not realized, and while the flow rate of the input gas was the same in each case, the slightly increased concentration of CO₂ in the latter determination would be significant.

Despite the slight increase in oxygen production noted here, subsequent experiments were performed with the urea concentration at 0.8 g/liter in order to make all the studies directly comparable. The interactions of changes in culture medium with compensating changes in the dilution rate have not been investigated.

TABLE 3
Effect of Urea Concentration in Culture Medium on
Oxygen Production
Conditions: Light Intensity, 23,000 Foot-Candles
Dilution Rate, 15.5% per hour

Urea Conc. (g/liter)	Suspension Density (percent)	Volume CO ₂ Supplied/hr (cc)	O ₂ Produced per Hour (cc)	Assimilatory Quotient
0.8	1.17	4272	3456	1.04
1.6	1.34	4488	3620	1.05

TABLE 4
Oxygen Production vs Light Intensity and Light Energy

Lamp Voltage	Light Intensity (ft-candles)	Power (watts)	O ₂ Production (cc/hr)	O ₂ Production (cc/watt hr)
170	9,000	4368	2500	0.57
230	23,000	7044	3900	0.55
245	30,000	7764	4240	0.55
260	34,000	8562	4500	0.53

Oxygen Production as a Function of Light Intensity and Electrical Energy

It had been assumed from the start of this investigation that the volume requirement of an algal system for submarine use might be excessive. Electrical power was regarded as the asset in abundance; therefore all efforts have been directed toward maximum oxygen production per liter of suspension, and this demands the use of high-intensity light sources. The dependence of oxygen production on light intensity is shown in Table 4, the data representing conditions in which the CO₂ supply was not limiting.*

Most noteworthy of the above relationships is the constant oxygen production per watt hour expended, practically independent of the light intensity. For a given gas exchanger, therefore, there is a characteristic oxygen production per watt hour, and this is borne out by a collateral study to be reported on at a later date (4). The design of the later unit is different from the six-lamp unit which forms the basis of this report; around a single G.E. Quartzline lamp is a 10-mm annulus through which the suspension is circulated. This provides a shorter light path through the cells; consequently the cells are more constantly illuminated than in the six-lamp unit. With this unit, a yield of 1.0 cc oxygen per watt hour is obtained.

DISCUSSION

Volume Requirement of an Algal System

In order that the estimate of volume requirement be as comprehensive as possible, a calculation

*The wattage of the lamps was measured by a wattmeter manufactured by the Jewell Electrical Instrument Co., and the data received from it are slightly higher than that submitted by the General Electric Co., manufacturer of the lamps.

tion has been made for each of two designs. The one referred to as the six-lamp unit is the subject of this report; the other concerns a unit with a 10-mm annular spacing around a single Quartzline lamp, to be the subject of a separate report (4).

For the purposes of this calculation, let us ignore the volume of a blower, or blowers, which will be necessary to force the ship's air through the gas exchanger, since this equipment will be common to almost any air-purification scheme. We will also ignore the volume of a centrifuge which would be operating continuously to separate the algal cells from the overflow suspension (the rate would be over 600 liters per hour), and the volume of a supply tank for fresh medium. Our estimate will include the volume of the shell of the unit; inside would be the light sources, encased in 50-mm cooling jackets, and the suspension.

Another important assumption to be made is that adequate stirring of the suspension will result from the rise of input gas bubbles through the suspension, and that the oxygen production of each hypothetical unit will be the same as its counterpart in the laboratory, where additional stirring was provided. Having made these assumptions for the sake of simplicity, we can make an estimate of the volume requirements of the two gas exchangers in question (Table 5).

The comparisons shown in Table 5 are based on the assumption that we would be providing the oxygen for 100 men, each requiring 620 liters of oxygen per day at standard temperature and pressure. Clearly there is much to be gained by using the shorter light path, perhaps one even less than the 10-mm annulus on which part of this estimate is based. The total volume requirement is decreased 40 percent with the shorter light path, and the power requirement is decreased by a third. There is one large disadvantage to such an ar-

TABLE 5
Oxygen, Power, and Volume Requirements of
Two-Gas Exchangers Having Different Light Paths,
for 100 Men

Light Path	Oxygen Production (cc/hr/liter at STP)	Volume of Suspension Required (liters)	Total Volume (liters)	Power Required (kw)
0.5 to 1.5 in.	670	3860	6330	5220
10 mm	1430	1810	3620	3225

rangement, and it is the tendency of the cells to stick to the walls of the container and to the cooling jackets. This sticking effect is not presumed to be a reflection of a change in the cell coating under these culture conditions, but rather an indication of the difficulty in providing sufficient turbulence around narrow passageways to prevent the cells from adhering to the walls. This matter of turbulence is the province of an engineer, but certain facets of it obvious to the authors are discussed below.

Sticking and Settling of Cells

A good circulation system is essential for an algal gas exchanger, because without it the cells either stick to the walls or they settle to the bottom; either situation results in a severe crippling of the oxygen production. There has been practically no such problem with the six-lamp unit described here, because of the extreme turbulence provided by the 3-in. stirrers connected to the 1/3-hp motor, but to scale this design up to the necessary suspension volume to support 100 men would be impractical because of the size of the motors.

The use of large volumes of finely dispersed bubbles through the system might provide sufficient turbulence to prevent the cells from sticking, and, if the aerators are properly spaced, from settling. But air bubbles provide a flotation effect also, and the cells would be concentrated near the surface of the suspension unless some auxiliary circulation system forced them back to the bottom. Fortunately the cells used in this study withstand the shearing action of centrifugal pumps with no apparent harm, and no practical difficulty other than the volume requirement is anticipated in providing this auxiliary circulation.

At present there seems to be no hope of using any other material than glass for the construction of the gas exchanger; the cells stick to Lucite more so than glass. Further, this plastic compound does not withstand intense light satisfactorily. One possibility to be explored will be the use of surface coatings such as Teflon on the glass surfaces of the container and cooling jackets.

It should be mentioned here that the lights must be mounted vertically in order to minimize the settling of cells. A cooling jacket of approximately 50 mm O.D. provides a broad base for such settling if placed in a horizontal position; another disadvantage of horizontal cooling jackets is the inevitable formation of large air bubbles within the jacket which displace some of the water from the jacket. For these reasons the cooling jackets must be positioned vertically, or at an acute angle, throughout the suspension.

Electrical Power Considerations

Assuming that a gas exchanger could be engineered to minimize the problem of sticking cells without compromising the volume appreciably, its biggest disadvantage at this writing would be the power requirement. As indicated in Table 5, it should be possible to provide oxygen for 100 men at a power expenditure of 3225 kw, but this is enormously greater than the 75 kw required by a Treadwell electrolytic generator. Presumably the dual purpose of an algal system—carbon dioxide removal and oxygen generation—would warrant the expenditure of more energy than is now required by the separate conventional systems, but the increase by several orders of magnitude would seem prohibitive.

The reasons for this excessive power requirement are the following: (a) the conversion of

electrical energy to visible light energy by an incandescent lamp (5) is performed at an efficiency of less than 10 percent, (b) much of the visible light thus produced is in the range of the spectrum where the quantum energy exceeds the requirements of the photosynthetic process, and this excess must be dissipated as heat, and (c) some of the incident light is not absorbed, particularly under conditions which effect maximum oxygen production per volume of suspension.

It is interesting to calculate the efficiency of the six-lamp unit on the basis of the caloric equivalent of oxygen produced per calorie of electrical energy. Assuming that the caloric equivalent of oxygen is 4.3 cal per liter, the efficiency of the unit when operated at 30,000 foot-candles is 0.28 percent.

Mention should be made here of the experiments by Burk and Warburg, described by Burk (6), by Emerson and Lewis (7), and by Franck (8,9) and others on the efficiency of the photosynthetic mechanism. While the quantum requirement for the production of one oxygen molecule is not agreed on by these researchers, their results show that the photosynthetic process is an efficient one (from one to twelve quanta per oxygen molecule). But in a mass-culture system such as the one described in this report, high efficiencies are unlikely. For example, the maximum oxygen production recorded during these studies was at a light intensity of 34,000 foot-candles, at which time some of the cells must have been solarized, because Sorokin and Krauss (10) found that inhibition resulted with the use of greater than 3000 foot-candles. It is possible to use light intensities greater than 3000 foot-candles because of the short exposure times provided the cells by rapid stirring, but the exploitation of this effect is limited by their gradual expulsion from the apparatus. Presumably the apparatus could be designed better to promote rapid stirring without necessarily displacing large volumes of suspension.

Other Light Sources

One way of increasing the efficiency of the system, from the power-requirement standpoint, would be to use fluorescent lamps, but the volume requirement with these lights would be increased greatly. Because of their relatively low intensity they could be used profitably only with suspensions in narrow annular spaces.

Lasers are capable of producing intense radiation in the visible region, but the efficiency of these new sources is so low at the present time that they are quickly removed from consideration. Their efficiency in converting electrical energy to light energy is only several tenths of a percent.

Perhaps the most optimistic development in the light sources is a still-experimental lamp which contains sodium vapor under pressure. Its yield of lumens per watt is roughly 6-1/2 times that of the Quartzline lamp, and it is an intense source of light, but the life expectancy of this lamp, and its cost, are still not known.

A breakthrough in lighting efficiency is clearly needed in order to make the algal system of oxygen generation feasible. Most desirable would be a high-intensity lamp whose output is predominantly in the red portion of the spectrum.

Foaming

A problem anticipated with large gas exchangers is the production of foam. Our experience has been, however, that there is no real foam problem when the cells are maintained in a rapidly growing condition. Because of the rather large gas volumes forced through the suspension in these experiments, it was inevitable that some spatter of cells to the top of the container would occur. Foam has not been a real problem, however, and it could be designed out of a large system. It has not been necessary to add an antifoam agent to the suspensions grown in the six-lamp unit. At a given light intensity, there seems to be an inverse relationship between the amount of foam and the dilution rate, which is consistent with the generally held view that the older cells are responsible for the foam formation.

Uniformity During a Given Run

It is natural to maintain a suspicious attitude on the reliability of biological systems. However, there is nothing wrong with the premise that constant results are obtainable with constant conditions, even in biological systems, and the results cited here are intended to substantiate this hypothesis.

Once the general behavior of the unit was known, and with reason to believe that long-term

TABLE 6
Summary of Week-Long Performance of Six-Lamp Unit

Light Intensity: 23,000 Foot-Candles
Electrical Power: 7040 Watts

Dilution Rate: 15.6% per hour
Gas Flow Rate: 4000 cc/min, containing
1.9% CO₂

Day	Suspension Density Percent Packed Cell Volume	Oxygen Production		Dilution Rate (ml/hr for 24 hr)
		Volume (cc/hr)	Standard Deviation (cc/hr)	
Monday	1.27 - 1.37	3432	145	Not measured
Tuesday	1.44 - 1.50	3565	30	964
Wednesday	1.43 - 1.47	3606	29	969
Thursday	1.41 - 1.44	3584	25	966
Friday	1.41 - 1.43	3638	24	950

stability was obtainable, the unit was operated from Monday morning through Friday afternoon under identical conditions of light intensity, gas-flow rate, dilution rate, and temperature. Readings were taken hourly from 8:30 to 4:30 each day, of the oxygen production and carbon dioxide absorption rates. The spread in these values for each day is shown in Table 6. It should be emphasized that for 16 hours out of each 24, the unit was totally unattended, and yet consistent results were obtained.

On the first day, of course, the system had not come to a steady state, but once the steady state had been established the unit gave remarkably reproducible results. The spread in the oxygen-production results on each of the days when steady-state conditions prevailed was less than 100 cc per hour, or less than 3 percent deviation. A large proportion of this small variability can be attributed to errors in reading the oxygen analyzer. The meter is calibrated in tenths of a percent; therefore the second decimal is an estimate, and an error of 0.01 percent on both the input and exit gases, at a flow rate of 4000 cc per minute, would constitute an error of 48 cc in the oxygen production.

It is the failing of most investigators, including the authors of this report, to cite the good results instead of the bad, and Table 6 is presented as a prime example of good results. Not all experiments have turned out as well, but the inference intended to be given here is that the algal system is stable if the conditions are uniform.

Reproducibility from One Run to Another

Having established this stability during one extended run, it is pertinent to explore the variability found in succeeding runs under what seemed to be identical conditions. These observations, which extended over a three-month period, are summarized in Table 7.

In making this survey, the data selected were obtained under the general conditions listed at the heading of the table, but individual dilution rates were not computed. The dilution represented a given flowmeter reading which usually amounts to 15.6 percent per hour, but because of the lack of sensitivity of the flowmeter a variation of 0.3 percent might be expected.

Another factor in the selection of data listed in Table 7 was that first-day results of a given run were excluded because the time necessary to attain a steady-state condition is usually more than eight hours. Otherwise the data represent a random selection; the average oxygen production in these experiments is within 100 cc of the average of the values shown in Table 6.

Photosynthetic Quotients

In the closed atmosphere of a submarine it would be necessary to compensate closely for the respiratory quotient of the crew, so that the air would have an unchanging composition. Much work has been done by Myers (11) and other investigators concerning the effect of various nitro-

TABLE 7
Variation in Oxygen Production at Different Times
Light Intensity: 23,000 Foot-Candles Power: 7040 Watts Dilution: 15.6%/hr

Date	CO ₂ Input (percent)	Gas-Flow Rate (cc/min)	CO ₂ Supplied (cc/hr)	Oxygen Production (cc/hr)
Oct. 12	1.83	4000	4390	3468
Oct. 16	1.79	4000	4300	3456
Oct. 18	1.86	4000	4470	3492
Oct. 26	1.88	4000	4510	3490
Jan. 15	1.95	3500	4100	3505
Average				3482
Standard Deviation				18

gen sources on the photosynthetic quotient (O₂ produced/CO₂ absorbed) of algae. The consensus has been that urea provides the proper photosynthetic quotient and that nitrates, for example, would produce more O₂ per unit of CO₂ absorbed than would be desirable.

NRL findings have been that medium containing urea as the nitrogen source provides a photosynthetic quotient generally between 1.03 and 1.06. Undoubtedly a higher quotient, around the desired level of 1.18, can be obtained with a combination of urea and nitrate, but no attempt has been made here to achieve this result.

Whenever the unit is freshly charged with a suspension which has been refrigerated, the photosynthetic quotient for the first hour or two is between 0.90 and 1.00. Any value less than 1.02 after the unit has "warmed up" is regarded as a danger sign that all is not well with the culture.

Gas Exchange as a Criterion of Steady-State Conditions

In most studies of algal culture the suspension density is taken as a measure of growth, and a constant suspension density under conditions of continuous culture is regarded as representative of steady-state conditions. This is the basis on which a chemostat is operated: when the transmission of light through a growing culture is decreased to a certain point, fresh culture medium is admitted to the growth chamber. This has been a useful tool, but NRL findings have been that changes in gas exchange anticipate by hours the

associated changes in suspension density. For this reason the gas-exchange criterion as a measure of growth is regarded as more sensitive than the change in suspension density.

An example of this sensitivity is shown in Fig. 16. These data were obtained at a time when the adequacy of the dilution rate with fresh medium was in question, and some crystalline urea was added to the suspension when a steady state had been reached. The purpose of the illustration is to show the magnitude of the changes in oxygen production and carbon dioxide absorption compared to

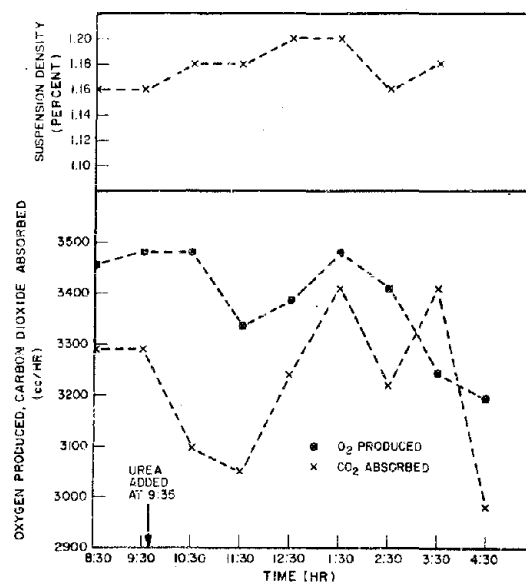

Fig. 16 - Variations in gas exchange compared to variations in suspension density after addition of extra urea

the almost imperceptible changes in suspension density. Some of the resultant changes in gas exchange are not understood.

A corollary finding of this short, incidental study was the importance of constant culture conditions. The dilution with fresh medium was maintained before and after the addition of urea, and for seven hours afterward the system had not yet come back to a steady state.

A Critical Look

As a result of 2-1/2 years of experimentation with the mass culture of algae, several impressions are dominant. Most important of these is the reliability of the system; to be sure, at times there are slight variations in the oxygen production which are unexplainable on the basis of present knowledge, but these variations are not of sufficient magnitude to affect the predicted oxygen production materially.

Another strong conviction prompted by the results obtained in these studies is the necessity of continuous culture techniques if reproducibility is to be expected. By constantly supplying the culture with fresh medium, the chemical composition of the culture becomes stabilized and uniform results may be expected; a good example of the converse of this was the effect produced by the batch-wise addition of urea (Fig. 16). Seven hours after this addition the gas exchange of the culture was still not stabilized.

Aside from the high power requirement of the system, the most serious drawback to an algal system for submarines might be the multiple water and electrical connections necessary. Approximately 6000 lamps, of the type used now, would be needed for a unit designed to sustain 100 men, and if we were to scale up the design of the six-lamp unit to include this number of lamps, a total of 24,000 connections would be necessary. If cooling jackets for each lamp were not necessary, and this might be so with more efficient lamps, the number of connections would be halved.

Tremendous savings in volume would result also with such a development. Assume that a light source, having the same dimensions as the Quartzline lamps used in this study, could be developed. If we were to place these lamps 20 mm apart and assume that the oxygen productivity would be the same as that now obtained with the 10-mm annulus, the total volume of the unit would be only 2100

liters. Compared with the 4870 liters total volume projected for a unit in which 50-mm cooling jackets would be provided for each lamp, this is "compact." Some increase in volume would be necessary to accommodate stainless steel coils through which cooling water could be passed, but this would not be significant.

Whether "cool" high-intensity lamps can be developed is not known. The surface temperature of the Quartzline lamps now available, when the intensity at the surface is 9000 foot-candles, is 165°C.

A factor to be considered in the complete development of an algal system is the effect of re-use of spent medium after it has been fortified with the necessary urea and salts. There is a lack of agreement among investigators concerning the buildup of autotoxins in the medium as growth proceeds, and this question would have to be settled. However, even assuming that such a condition existed, it is conceivable that a toxicant could be removed by passing the spent medium through a charcoal adsorber before the necessary nutrients were added.

The amount of salts and urea necessary to keep the medium at its proper strength is not great. Approximately 29 pounds of urea and three to five pounds of salts would be used per day in a unit supplying oxygen for 100 men. Over a 60-day submergence time this would require approximately a ton of materials, not a prohibitive burden. On the disposal side, approximately 8.5 cu ft of cells would be centrifuged each day; these could be packaged, then dumped.

In summation then, the algal system has the merit of a single system for the production of oxygen and the removal of carbon dioxide. The chemical compounds necessary for its operation are not dangerous; the electrolytic production of oxygen suffers by comparison in this respect because of its use of strong acids and its production of large amounts of inflammable hydrogen. The algal system has an added factor in its capacity to scrub out certain contaminants from the atmosphere.

On the debit side, the major factor at the present time is the high electrical power requirement. A less tangible disadvantage would be the multiple connections necessary in powering and cooling the light sources. Also to be considered presently is the need for glass cooling jackets; there should be no problem in the use of stainless steel as the

framework for the unit, so long as provision could be made for visual inspection of the unit at various places. If highly efficient incandescent lamps become available there would be no real need for any glass components. Problems still exist in the type and amount of agitation necessary to keep the cells from sticking to the container.

With these considerations in mind, one must conclude that the algal system at the present time would not be as practical as the combination of systems now in use. Perhaps the situation will be significantly changed in ten years.

SUMMARY

An algal gas exchanger having the following characteristics has been described:

1. The culture is contained in a glass cylinder 10 in. O.D. and 10 in. high, the volume of suspension being 6200 ml.

2. Rapid stirring of the suspension is provided by a 1/3-hp motor.

3. Light energy is supplied by six high-intensity incandescent lamps, uniformly spaced within the container and enclosed in cooling jackets. The average light path in the system is of the order of 16 mm.

4. Fresh culture medium is added continuously to the suspension by a constant-head device. At a given light intensity and dilution rate the suspension establishes an equilibrium density.

5. Constant air-CO₂ mixtures are provided at flow rates up to 6000 cc per minute. Oxygen and carbon dioxide analyses of the input and exit gases are made by appropriate electronic analyzers.

The results obtained with the unit described are as follows:

1. Light intensity is the dominant factor in oxygen production.

2. There is a strong correlation between the rate at which CO₂ is supplied to the suspension and the rate of O₂ production. There also is a correlation, but less accurate, between the CO₂ content of the exit gas and the O₂ production, at a given flow rate of input gas.

3. The reproducibility of the algal system is better than expected. In a week-long run, under continuous conditions of light intensity and dilution rate, the greatest variation in oxygen production on any day was less than 3 percent.

4. The highest production rate of oxygen with the six-lamp unit was 4500 cc per hour at 34,000 foot-candles, which was the highest light intensity available with this unit.

5. Most significant of the foreseeable difficulties with the algal system is its high energy requirement, approximately 30 to 50 kw required per man, depending on the design of the unit.

6. On a total-volume basis the algal system is competitive with existing systems for carbon dioxide removal and oxygen production. Its power consumption, however, would be at least 30 times as great as other systems with the incandescent-light sources currently available.

FUTURE PLANS

It is felt that the contents of this report satisfy the major objective of the current study, namely to determine the feasibility of the algal system as a means of maintaining the proper oxygen balance in a submarine atmosphere. However, there are some unanswered questions which come to mind as a direct result of these studies, and these should be investigated:

1. What is the upper limit of CO₂ concentration of the effluent gas at which an effect on oxygen production is still noted? As a corollary, at what rate of CO₂ input is this same effect noted?

2. What is the minimum suspension density necessary to produce the maximum oxygen at each of the light intensities used? By maintaining this minimum density with a high dilution rate, the growth rate of the algae would be a maximum. There is reason to believe that the problem of foaming would thereby be minimized.

3. What effect would reconstituted medium, rather than completely fresh medium, have on the stability or the oxygen production of the system? It has been assumed during this study that the practice in submarine use would be to centrifuge the cells from the overflow suspension and add the required minerals and urea to the supernatant before returning it to the supply tank.

4. What is the optimum depth of suspension to be illuminated? An answer to this question will determine the ultimate volume that a gas exchanger must require. Continued experimentation with the one-light unit referred to in this report should settle this question.

5. Can thin surface coatings such as Teflon materially reduce the adhesion of algal cells to glass?

6. Would it be of advantage to use an organism which has less tendency to stick to glass, though its growth rate might be less than that of the organism used in this study?

7. What is the difference in the composition of cells grown under CO₂-limited and CO₂-excess conditions?

Most of these problems would have a bearing on the development of a gas exchanger for submarine use, and continued experimentation might make such equipment feasible. But a stronger argument for continuation of these studies would be the increase of knowledge regarding the factors governing oxygen production. The equipment now available at NRL makes possible some investigations which were not feasible previously. A spectrophotometer with a flame photometer attachment and a photomultiplier tube can be used to determine the trace-element composition of algal cells. A phase microscope can provide information on structural changes in the cells as a result of changes in culture conditions. Electronic carbon dioxide and oxygen analyzers have already proven their worth in determining the concentration changes of these gases in a dynamic system.

The continuous-culture technique developed here is a valuable tool in providing a constant supply of cells with similar past histories. This technique should be extremely useful in determining the changes in growth or gas exchange with changes in the culture medium. By switching from one culture medium to another during a continuous experiment, it should be possible to detect minor changes in the response of the cells under these different culture conditions. An example of this might be the resolution of the problem in determining whether calcium is an essential component of the culture medium.

One investigation which has been assigned a high priority in future studies is the effect of pressure on the performance of a gas exchanger. As pointed out earlier, there is a correlation between the oxygen production and the percentage of CO₂ left in the gas stream at a given flow rate of gas. This points to the solubility of CO₂ in the culture medium as a rate-limiting step which can be hastened by an increase in the total pressure at which the unit is operated. A close look at data already

available suggests that a doubling of the pressure might result in a 10-percent increase in oxygen production.

The foregoing paragraphs provide a framework on which future research is to be conducted. It is conceivable that the findings of these basic studies will have application in the solution of problems ranging from an understanding of marine growth to the habitability aspects of space flights.

ACKNOWLEDGMENTS

The authors wish to acknowledge the support and encouragement provided by Captain Jack Kinsey, Code SP003, Bureau of Naval Weapons. Also, thanks are due to Dr. John M. Leonard of NRL for his interest and guidance in this project.

REFERENCES

1. Leonard, J.M., "Algae and Submarine Habitability, an Appraisal," NRL Report 5182, Aug. 26, 1958
2. Hannan, P.J., Patouillet, C., and Shuler, R., "Studies of Oxygen Production by Mass Culture of Algae," NRL Report 5689, Dec. 6, 1961
3. Davis, E.A., et al., "Laboratory Experiments on Chlorella Culture at the Carnegie Institution of Washington," Chapter 9 in "Algal Culture from Laboratory to Pilot Plant," J.S. Burlew, editor, Carnegie Inst. of Washington, 1959
4. Shuler, R.L., "Some Factors Affecting the Oxygen Production by Algae in a Small Culture Unit," NRL Report in preparation
5. Knowlton, A.E., editor, "Standard Handbook for Electrical Engineers," New York: McGraw-Hill, p. 1481, 1949
6. Burk, D., Cornfield, J., and Schwartz, M., "The Efficient Transformation of Light into Chemical Energy in Photosynthesis," *Scientific Monthly* 73:213-223 (1951)
7. Emerson, R., and Lewis, C., "Factors Influencing the Efficiency of Photosynthesis," *Am. J. Botany* 26:808 (1939)
8. Franck, J., "An Interpretation of the Contradictory Results in Measurements of the Photosynthetic Quantum Yields and Related Phenomena," *Arch. Biochem.* 23:297 (1949)
9. Franck, J., "Participation of Respiratory Intermediates in the Process of Photosynthesis as an Explanation of Abnormally High Quantum Yields," *Arch. Biochem. Biophys.* 45:190 (1953)
10. Sorokin, C., and Krauss, R.W., "The Effects of Light Intensity on the Growth Rates of Green Algae," *Plant Physiology* 33:109-113 (1958)
11. Myers, J., "Study of a Photosynthetic Gas Exchanger as a Method of Providing for the Respiratory Requirements of the Human in a Sealed Cabin," Report to Air Research and Development Command, Contract AF 18(600)-618, 1955-1957

APPENDIX A
BURK'S MEDIUM

Major Constituents	Amount (grams/liter)
MgSO ₄ 7 H ₂ O	5.0
KH ₂ PO ₄	2.5
NaCl	2.0
Urea	0.4

Micronutrients	Conc. Source Compd. (mg/liter)	Conc. Trace Element (ppm)	M.E.Q. Element (liter)
Fe - EDTA	4	1 Fe	5.36×10^{-2}
CaCl ₂	22	8 Ca	.8
H ₃ BO ₃	5.7	1 B	.6
MnCl ₂ 4 H ₂ O	3.6	1 Mn	3.64×10^{-2}
ZnSO ₄	0.44	0.18 Zn	5.5×10^{-2}
CuSO ₄ 5 H ₂ O	0.158	0.04 Cu	1.25×10^{-2}
(NH ₄) ₆ Mo ₇ O ₂₄ 5 H ₂ O	0.035	0.019 Mo	1.19×10^{-3}
NaVO ₃	2	0.84 V	8.24×10^{-2}

UNCLASSIFIED

U.S. Naval Research Laboratory, Report 5954.
 A STUDY OF THE FEASIBILITY OF OXYGEN PRODUCTION BY ALGAE FOR NUCLEAR SUBMARINES, by P. J. Hannan, R. L. Shuler, and C. Patouillet. 21 pp. and figs. August 12, 1963.

The mass culture of algae has been considered as a means of removing carbon dioxide and replenishing oxygen in the atmosphere of a nuclear submarine. For the past 2-1/2 years the feasibility of this method has been investigated in the laboratory by measuring the growth rate and the oxygen production of the Sorokin strain of *Chlorella pyrenoidosa* under various conditions of culture.

The results obtained with a small pilot plant containing 6200 ml of algal suspension have been evaluated; the effects of light intensity, rate of carbon dioxide supply, and other variables were part of this study. Light energy was supplied by six 1500-watt incandescent lamps which extended through the suspension and were encased in 50-mm O.D. cooling jackets. When the light intensity at the surface of these jackets was 34,000 foot-candles (the limit with the equipment at hand), the oxygen production was 4500 cc per hour.

UNCLASSIFIED

(Over)

- I. Nuclear submarines - Habitability
2. Algae - Appl.
3. Oxygen Production

- I. Hannan, P. J.
- II. Shuler, R. L.
- III. Patouillet, C.

UNCLASSIFIED

U.S. Naval Research Laboratory, Report 5954.
 A STUDY OF THE FEASIBILITY OF OXYGEN PRODUCTION BY ALGAE FOR NUCLEAR SUBMARINES, by P. J. Hannan, R. L. Shuler, and C. Patouillet. 21 pp. and figs. August 12, 1963.

The mass culture of algae has been considered as a means of removing carbon dioxide and replenishing oxygen in the atmosphere of a nuclear submarine. For the past 2-1/2 years the feasibility of this method has been investigated in the laboratory by measuring the growth rate and the oxygen production of the Sorokin strain of *Chlorella pyrenoidosa* under various conditions of culture.

The results obtained with a small pilot plant containing 6200 ml of algal suspension have been evaluated; the effects of light intensity, rate of carbon dioxide supply, and other variables were part of this study. Light energy was supplied by six 1500-watt incandescent lamps which extended through the suspension and were encased in 50-mm O.D. cooling jackets. When the light intensity at the surface of these jackets was 34,000 foot-candles (the limit with the equipment at hand), the oxygen production was 4500 cc per hour.

UNCLASSIFIED

(Over)

1. Nuclear submarines - Habitability
2. Algae - Appl.
3. Oxygen Production

- I. Hannan, P. J.
- II. Shuler, R. L.
- III. Patouillet, C.

UNCLASSIFIED

U.S. Naval Research Laboratory, Report 5954.
 A STUDY OF THE FEASIBILITY OF OXYGEN PRODUCTION BY ALGAE FOR NUCLEAR SUBMARINES, by P. J. Hannan, R. L. Shuler, and C. Patouillet. 21 pp. and figs. August 12, 1963.

The mass culture of algae has been considered as a means of removing carbon dioxide and replenishing oxygen in the atmosphere of a nuclear submarine. For the past 2-1/2 years the feasibility of this method has been investigated in the laboratory by measuring the growth rate and the oxygen production of the Sorokin strain of *Chlorella pyrenoidosa* under various conditions of culture.

The results obtained with a small pilot plant containing 6200 ml of algal suspension have been evaluated; the effects of light intensity, rate of carbon dioxide supply, and other variables were part of this study. Light energy was supplied by six 1500-watt incandescent lamps which extended through the suspension and were encased in 50-mm O.D. cooling jackets. When the light intensity at the surface of these jackets was 34,000 foot-candles (the limit with the equipment at hand), the oxygen production was 4500 cc per hour.

UNCLASSIFIED

(Over)

- I. Nuclear submarines - Habitability
2. Algae - Appl.
3. Oxygen Production

- I. Hannan, P. J.
- II. Shuler, R. L.
- III. Patouillet, C.

UNCLASSIFIED

U.S. Naval Research Laboratory, Report 5954.
 A STUDY OF THE FEASIBILITY OF OXYGEN PRODUCTION BY ALGAE FOR NUCLEAR SUBMARINES, by P. J. Hannan, R. L. Shuler, and C. Patouillet. 21 pp. and figs. August 12, 1963.

The mass culture of algae has been considered as a means of removing carbon dioxide and replenishing oxygen in the atmosphere of a nuclear submarine. For the past 2-1/2 years the feasibility of this method has been investigated in the laboratory by measuring the growth rate and the oxygen production of the Sorokin strain of *Chlorella pyrenoidosa* under various conditions of culture.

The results obtained with a small pilot plant containing 6200 ml of algal suspension have been evaluated; the effects of light intensity, rate of carbon dioxide supply, and other variables were part of this study. Light energy was supplied by six 1500-watt incandescent lamps which extended through the suspension and were encased in 50-mm O.D. cooling jackets. When the light intensity at the surface of these jackets was 34,000 foot-candles (the limit with the equipment at hand), the oxygen production was 4500 cc per hour.

UNCLASSIFIED

(Over)

1. Nuclear submarines - Habitability
2. Algae - Appl.
3. Oxygen Production

- I. Hannan, P. J.
- II. Shuler, R. L.
- III. Patouillet, C.

UNCLASSIFIED

Oxygen production increases with light intensity, but the oxygen produced per watt of electrical energy expended is constant over a wide range of light intensities. The amount of electrical energy required to provide enough oxygen for one man is between 30 and 50 kw, depending on the design of the gas exchanger. This high requirement makes the process prohibitive at present, but the development of more efficient high-intensity light sources could change the outlook.

The dependability of the algal system in providing a constant supply of oxygen has been assured by this study; also, the volume requirements of the algal system are competitive with existing systems for carbon dioxide removal and oxygen production.

UNCLASSIFIED

UNCLASSIFIED

Oxygen production increases with light intensity, but the oxygen produced per watt of electrical energy expended is constant over a wide range of light intensities. The amount of electrical energy required to provide enough oxygen for one man is between 30 and 50 kw, depending on the design of the gas exchanger. This high requirement makes the process prohibitive at present, but the development of more efficient high-intensity light sources could change the outlook.

The dependability of the algal system in providing a constant supply of oxygen has been assured by this study; also, the volume requirements of the algal system are competitive with existing systems for carbon dioxide removal and oxygen production.

UNCLASSIFIED

UNCLASSIFIED

Oxygen production increases with light intensity, but the oxygen produced per watt of electrical energy expended is constant over a wide range of light intensities. The amount of electrical energy required to provide enough oxygen for one man is between 30 and 50 kw, depending on the design of the gas exchanger. This high requirement makes the process prohibitive at present, but the development of more efficient high-intensity light sources could change the outlook.

The dependability of the algal system in providing a constant supply of oxygen has been assured by this study; also, the volume requirements of the algal system are competitive with existing systems for carbon dioxide removal and oxygen production.

UNCLASSIFIED

UNCLASSIFIED

Oxygen production increases with light intensity, but the oxygen produced per watt of electrical energy expended is constant over a wide range of light intensities. The amount of electrical energy required to provide enough oxygen for one man is between 30 and 50 kw, depending on the design of the gas exchanger. This high requirement makes the process prohibitive at present, but the development of more efficient high-intensity light sources could change the outlook.

The dependability of the algal system in providing a constant supply of oxygen has been assured by this study; also, the volume requirements of the algal system are competitive with existing systems for carbon dioxide removal and oxygen production.

UNCLASSIFIED

UNCLASSIFIED

UNCLASSIFIED