

UNCLASSIFIED

AD 4 2 1 4 5 1

DEFENSE DOCUMENTATION CENTER

FOR

SCIENTIFIC AND TECHNICAL INFORMATION

CAMERON STATION, ALEXANDRIA, VIRGINIA



UNCLASSIFIED

NOTICE: When government or other drawings, specifications or other data are used for any purpose other than in connection with a definitely related government procurement operation, the U. S. Government thereby incurs no responsibility, nor any obligation whatsoever; and the fact that the Government may have formulated, furnished, or in any way supplied the said drawings, specifications, or other data is not to be regarded by implication or otherwise as in any manner licensing the holder or any other person or corporation, or conveying any rights or permission to manufacture, use or sell any patented invention that may in any way be related thereto.

ANTENNA LABORATORY

Technical Report No. 71

WIDE-BAND CORRUGATED SURFACE ANTENNA

by

MARVIN LEE WAHL

Contract No. AF33(657)-10474

Hitch Element Number 62405484

760 D-Project 6278, Task 6278-01

June 1963

Sponsored by

AERONAUTICAL SYSTEMS DIVISION

WRIGHT-PATTERSON AIR FORCE BASE, OHIO

Project Engineer — James Rippin — ASRNC-3

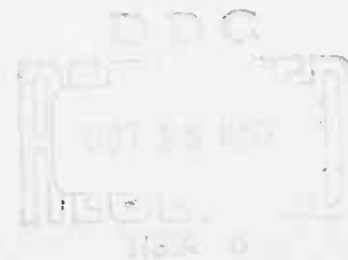

ELECTRICAL ENGINEERING DEPARTMENT
ENGINEERING EXPERIMENT STATION
UNIVERSITY OF ILLINOIS
URBANA, ILLINOIS

CATALOGED BY DDC

AS AD No. 421451

Antenna Laboratory

Technical Report No. 71

WIDE-BAND CORRUGATED SURFACE ANTENNA

by

Marvin Lee Wahl

Contract No. AF33(657)-10474
Hitch Element Number 62405484
760 D-Project 6278, Task 6278-01

June 1963

Sponsored by

AERONAUTICAL SYSTEMS DIVISION

WRIGHT-PATTERSON AIR FORCE BASE, OHIO

Project Engineer - James Rippin - ASRNCF-3

Electrical Engineering Department
Engineering Experiment Station
University of Illinois
Urbana, Illinois

CONTENTS

	Page
1. Introduction	1
2. Basic Considerations	3
3. Theoretical k - β Diagram for Corrugated Surfaces	6
3.1 Calculation of the Theoretical k - β Diagram	6
3.2 Interpretation of Theoretical k - β Diagram	10
3.3 Modification for Realizing a Backfire Condition	11
4. Experimental Results	16
4.1 The Corrugated Surface	16
4.2 Uniform Version of the Corrugated Surface with Multiple Loop Feed	17
4.3 The Wide-Band Corrugated Surface Antenna	20
5. Conclusion	26
Bibliography	28

ILLUSTRATIONS

Figure Number		Page
1	Examples of LP Flush Mounted Antennas (Feeds Not Shown)	2
2a	Periodically Loaded Waveguide	4
2b	Two Line Directional Coupler	4
3a	Theoretical and Experimental $k-\beta$ Diagram of Uniform Corrugated Surface	7
3b	Uniform Corrugated Surface	7
4	$k-\beta$ Diagram Showing Coupling of Modes	12
5	Transmission Line Periodically Loaded with Alternately Transposed Loops	13
6	Uniform Letter-Rack Antenna 21 Cavities Slot Depth $\lambda/4$ at 750 MC	15
7	$k-\beta$ Diagram of Uniform Corrugated Surface with Multiple Loop Feed	18
8	Three Patterns of the Uniform Letter-Rack Antenna	19
9	The LP Letter-Rack Antenna Last Slot is $\lambda/4$ at 850 MC $\tau = .97$ $h/d = 4.5/1$ 37 Elements $\alpha = 9^\circ$	21
10	Typical Near Field Amplitude of the Log-Periodic Letter-Rack Antenna	22
11	Impedance of a Wide-Band Corrugated Surface Antenna	23
12	Far Field Patterns of the Log-Periodic Letter-Rack Antenna	24
13	Log-Periodic Folded Dipole Array	

ACKNOWLEDGEMENT

The author wishes to thank all members of the Antenna Laboratory who gave him help and encouragement. The guidance of his advisor, Professor Raj Mittra, is particularly appreciated. Thanks are also due to Messrs. Richard Peterson and Dennis E. Stropes who performed many of the measurements.

This work was sponsored by the United States Air Force, Wright-Patterson Air Force Base, under Contract number AF33 (657)-10474, for which the author is grateful.

1. INTRODUCTION

To the knowledge of the author, no suitable flush-mounted broadband antenna of LP (log-periodic) design has been reported in the literature. Some of the types of designs for flush-mounted antennas which have been attempted by various workers are shown in Figure 1.

Figure 1a is a typical example of a class of structures which is fabricated by starting with a planar LP structure which has a satisfactory but bidirectional pattern, i.e., it radiates symmetrically in both hemispheres above and below the antenna. In order to have the energy radiating in the top half alone, the lower portion is usually blocked off with a series of cavities or even a single cavity. Most of these have been found to exhibit poor performance as broad-band antennas.

Many of the difficulties with the above scheme may be attributed to the reflections from the cavity back used with the planar structure. A procedure shown in Figure 1b, which has been used by Stang¹ to circumvent this, involves the use of a cavity coated with a lossy material. This does not seem to be a very useful solution to the problem if noise and power considerations are taken into account.

Figure 1c shows another configuration that seemingly looks like a dual of the LP dipole antenna. This will not work because the transmission line at the input would be essentially short-circuited by the shunt loops as they got smaller and smaller to satisfy the scaling conditions.

There may be ways of getting around this, but a direct approach would be preferable and it is the purpose of this paper to outline one such approach. Some of the basic principles for LP design will be discussed and applied to synthesize a flush-mounted log-periodic antenna which has been named the Letter-rack antenna. It is an integrated system of slots forming a corrugated surface and a series of loops which will be examined by the theory of coupled modes.

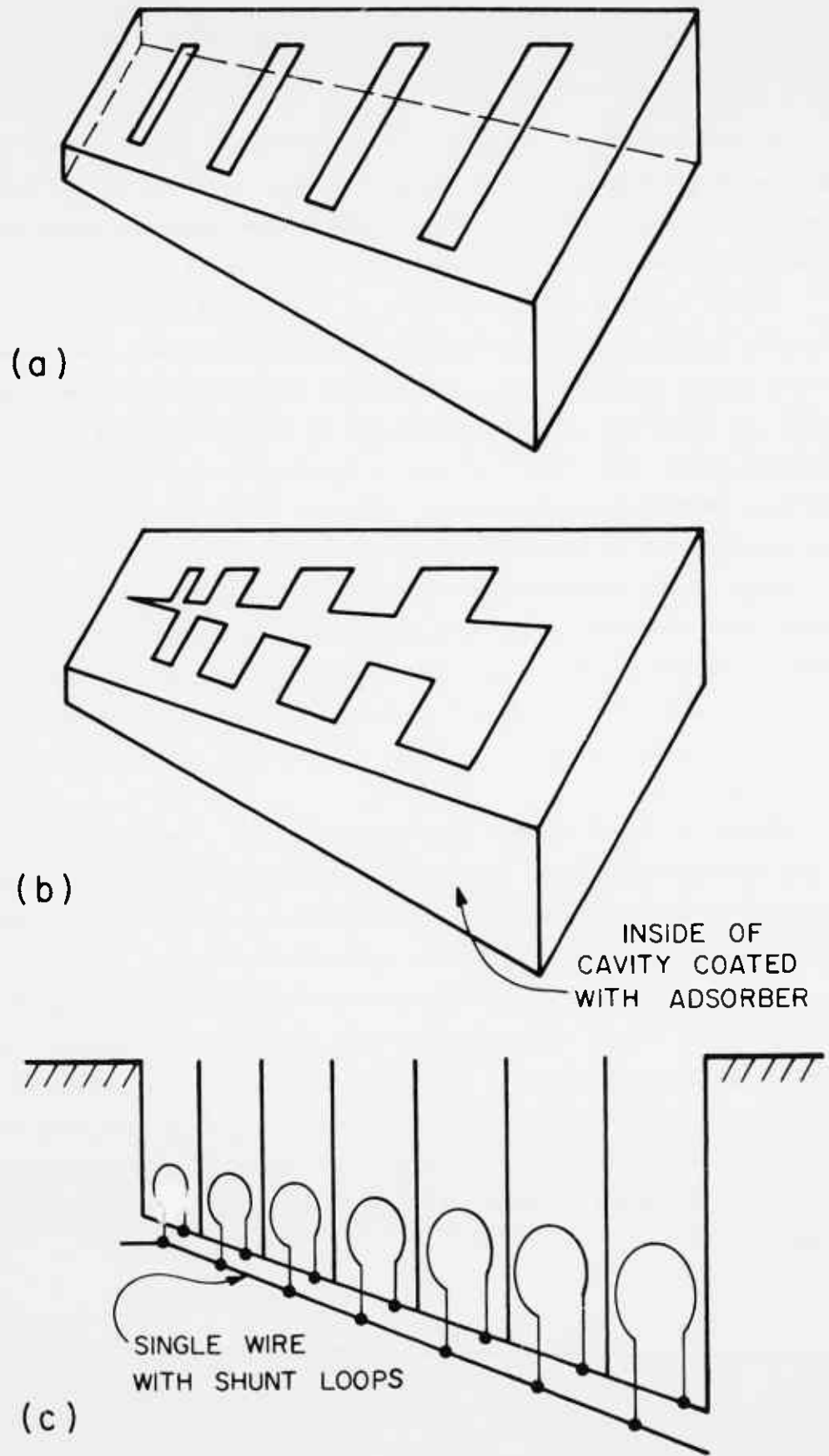

Figure 1. Examples of LP Flush Mounted Antennas Feeds (Not Shown)

2. BASIC CONSIDERATIONS

The purpose here is to outline some of the common design principles of successful LP antennas. So far only backfire types of structures have lent themselves to good LP design. Many of these antennas are built from periodic structures whose propagation constant is complex in certain frequency ranges, i.e., the solution of its characteristic equation is complex valued. The complex solution often referred to as the leaky wave solution assures the decay of fields along the structure away from the feed point. The term leaky wave solution is often used synonymously with a fast wave solution, i.e., one for which the propagation constant associated with one or more of the space harmonics has a real part β_r less than k , where k is the free space wave number. A complex wave does not need to be fast in order for the structure supporting it to radiate effectively. This does not need to be construed to mean that a slow wave would be better than a fast wave. Here the term complex wave will be used to indicate both fast waves and attenuating slow waves.

Although the supporting of a complex wave is necessary, it is not a sufficient condition for a uniform structure to be suitable for LP design. It is suggested that a filter type cutoff frequency region which is often referred to as a "stop-band" is the key to successful LP design. This statement must be interpreted very carefully. Consider, for instance, the two configurations shown in Figure 2. The loaded wave guide acts as a filter and has passbands and stop-bands. In the stop-band, the structure presents a reactive impedance to the source and all the energy launched is reflected back into the generator. In addition, the high attenuation of this mode results in little energy left in the end of the structure. Now consider the two line contra-directional coupler. That also has little end effect in line A because almost all of the energy can be coupled to line B. In contrast to the cutoff filter waveguide, the coupler may be so designed as to have little reflection back into the generator end of line A. It may be misleading to use the term stop-band in connection with this coupler without adequate explanation, as it would suggest a behavior similar to the filter structure.

These examples have interesting analogies to antenna structures. The filter type of configuration resembles a class of antennas which support complex waves, but these waves couple poorly to space. Most of the energy launched on

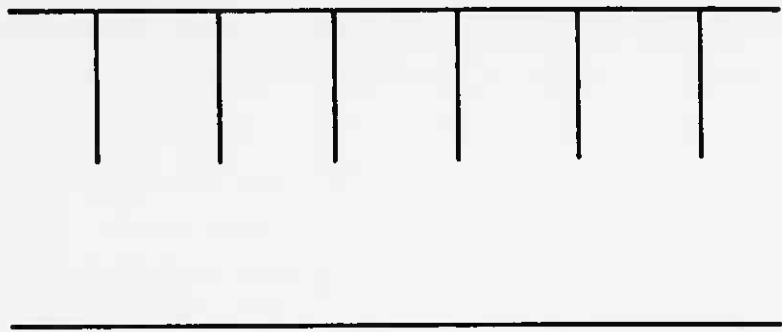

Figure 2a. Periodically Loaded Waveguide

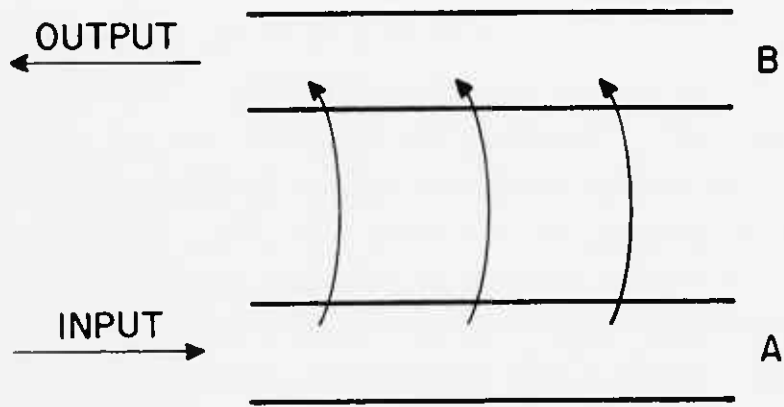

Figure 2b. Two Line Directional Coupler

the surface is reflected back to the feed end and standing waves are set up on the structure. As their impedance and patterns are usually quite frequency dependent, antennas belonging to this class do not lend themselves for wideband design.

The coupler is analogous to a class of antennas whose complex waves radiate effectively into space. Consequently, the standing waves on the structure are small and most of the energy radiates off the desired direction. Line A would be analogous to the guiding structure and line B could be thought of as the space into which the antenna is radiating. This class of antennas has a better broadbanding potential and this is the key to successful LP design.

To summarize, successful LP design is based on the following considerations:

1. The wave should favor backfire radiation, i.e., the main radiation should be toward the feed.
2. The LP structure should support a complex wave region where the wave attenuates. This region is to be preceded by a transmission region where there is little attenuation. The latter condition is particularly important from impedance considerations.
3. The complex wave should couple effectively to space and should reflect little energy back to the generator exciting the guiding structure. However, it is not a necessary criterion that the wave be fast, i.e., the real part of β need not be smaller than k .

It is not implied here that the above conditions are both necessary and sufficient, and a few exceptions also exist, but they are definitely the common characteristic of most of the successful LP antennas built to date.

3. THEORETICAL k - β DIAGRAM FOR CORRUGATED SURFACES

3.1 Calculation of the Theoretical k - β Diagram

One approach to studying the LP antennas is by considering them to be locally periodic along the structure.² The period increases with the increasing distance from the apex. Therefore, knowing what is happening to a periodic structure as a function of frequency gives considerable insight into what is happening in a LP version of that structure as a function of distance along it away from the apex. Hence, the importance of the Brillouin diagram showing kh as a function of βd where at a given frequency and height in the LP structure the approximate local phase constant βd could be obtained from the Brillouin diagram for the uniform version. Although the corrugated surface shown in Figure 3b will be seen to be unsuitable for use by itself as a broad-band antenna, its k - β diagram will be useful in the coupled mode theory analysis of the Letter-rack antenna.

The corrugated surface has been suggested as a substitute for a reactance surface, and the propagating characteristic of the latter, both unmodulated and modulated, has been reported.³ However, the approximation of a corrugated surface to being a constant-reactance surface is only good over a narrow band of frequencies. As a little thought will show, the corrugated surface is not a constant-reactance type, but is highly dispersive. The calculating of the k - β diagram has been discussed by Brillouin⁴ and Hurd.⁵ Hurd's work, which is the latest, has used a function-theoretic approach to obtain the characteristic equation, and he has restricted himself to pure real or surface wave types of solution. An alternate approach for deriving the equation for β will be presented.

The first part of the formulation follows exactly the procedure used by Hurd. In the region above the slots it is assumed that there exists a wave proceeding in the $+z$ direction. This wave will be assumed to have three field components only, E_y , E_z , H_x . The problem is thus a scalar one, and all the field components may be derived from H_x . The appropriate equations are:

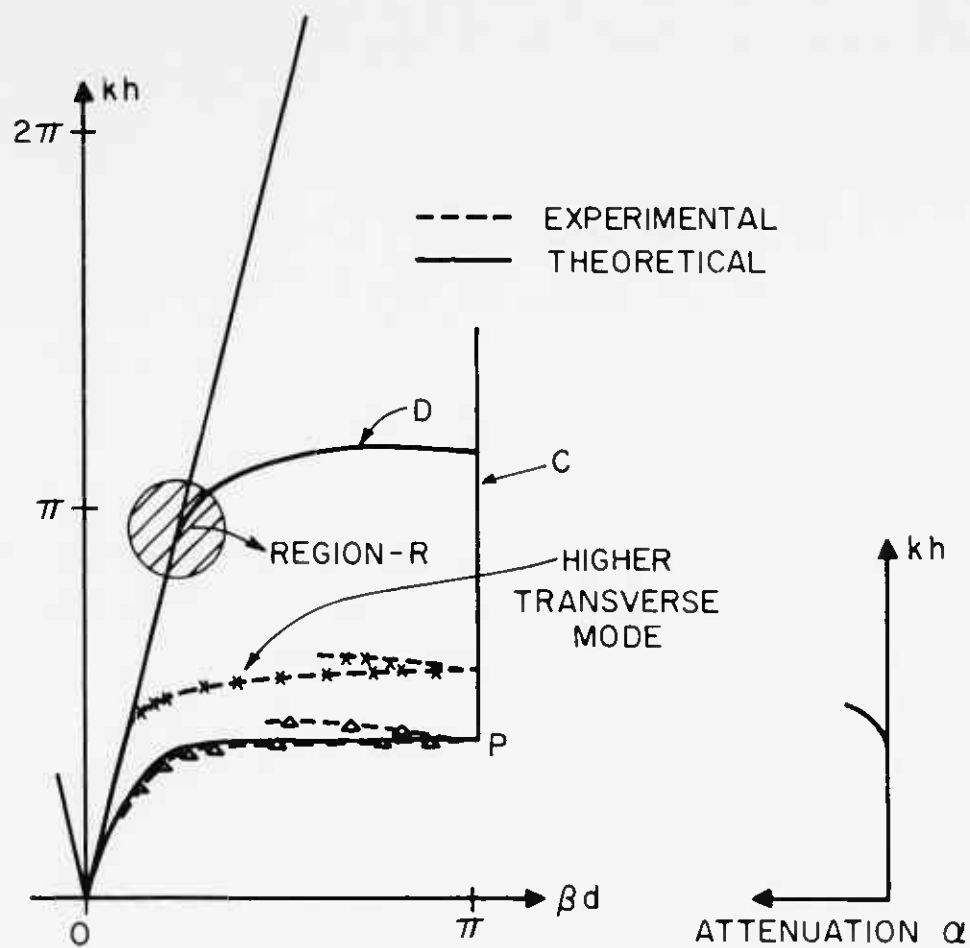

Figure 3a. Theoretical and Experimental k - β Diagram of Uniform Corrugated Surface

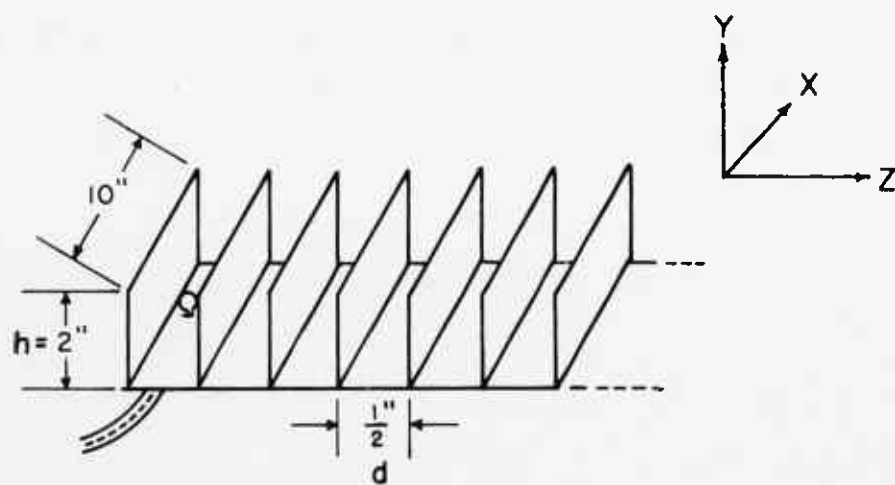

Figure 3b. Uniform Corrugated Surface

$$\begin{aligned}
 E_y &= - (i/\omega\epsilon) \partial/\partial z (H_x) \\
 E_z &= (i/\omega\epsilon) \partial/\partial y (H_x)
 \end{aligned}
 \tag{1}$$

$$(\partial^2/\partial y^2 + \partial^2/\partial z^2 + k^2) H_x = 0$$

On account of the periodic nature of the structure, the field above the slots will not be a simple wave but will be a summation of an infinite number of waves of differing amplitudes and phase constants:

$$\begin{aligned}
 H_x &= \sum_{n=-\infty}^{\infty} A_n e^{-a_n y - i\beta_n z} \\
 a_n &= (\beta_n^2 - k^2)^{\frac{1}{2}}
 \end{aligned}
 \tag{2}$$

$$\beta_n = \beta_0 + 2n\pi/d$$

$$(n = 0, \pm 1, \pm 2, \dots)$$

β_0 is the characteristic propagation constant. Let it be assumed that only a TEM mode propagates in the trough region.

The field in the v th slot may be written as

$$H_x^{(v)} = \sum_{m=0}^{\infty} \beta_m^{(v)} \cos \gamma_m (y+h) \cos (m\pi z v/d), \quad y < 0$$

$$\gamma_m = \sqrt{k^2 - \frac{m^2 \pi^2}{d^2}}$$

To derive the characteristic equation one matches the E_z and H_x field at $y=0$. Following Hurd, the following determinantal equation may be derived after some algebra:

$$\sum_{n=-\infty}^{\infty} A_n \left\{ \frac{1}{a_n - \delta_m} + \frac{e^{-2i\gamma_m h}}{a_n + \delta_m} \right\} = 0 \quad (4)$$

$$m = 0, 1, \dots, \infty$$

where

$$A_n = \beta_n e^{i\beta_n d/2} A_n$$

$$\delta_m = i\gamma_m, \quad \delta_0 = ik$$

The infinite set of equations has a form similar to the one obtained in the case of a finite bifurcation in a waveguide. This problem has been discussed thoroughly by Mittra.⁶ Using the method outlined in that paper for expanding determinants of the type under consideration, one obtains the following expression for the determinantal equation.

$$\Delta + \sum_{m=0}^{\infty} e^{-2i\gamma_m h} \Delta(-\delta_m) + \sum_{n=m+1}^{\infty} \sum_{m=0}^{\infty} e^{-2(\delta_m + \delta_n)h} \Delta(-\delta_m, -\delta_n) + \dots = 0 \quad (5)$$

The determinant Δ is a double alternant (for details see Muir⁷) and may be expressed as a ratio of products involving a_n and δ_m .

The desired determinantal equation is

$$2kh = \pi - 2 \sin^{-1} (k/\beta_0) + \frac{kd}{2\pi} \ln 2 + \tau(\psi_1, kd/\pi) - \tau(\psi_2, \frac{kd}{2\pi}) - \tau(\psi_3, \frac{kd}{2\pi}) \quad (6)$$

where

$$\tau(u, v) = \sum_{n=1}^{\infty} \sin^{-1} (u_n - \frac{v}{n})$$

and

$$\psi_{1n} = \frac{kd}{n\pi}, \quad \psi_{2n} = \frac{k}{\beta_n}, \quad \psi_{3n} = \frac{k}{|\beta_{-n}|}$$

The k - β diagram was calculated for the corrugated surface structure using Equation (6) and the results are shown in Figure 3a. Note particularly that above the turnover point P there exists a pair of complex conjugate solutions with the β equal to π . No other solutions were found in this range, although a numerical search for a possible root was made on a digital computer on a very thorough basis. A typical higher order solution is shown by curve D in Figure 3a. A thorough search was also made for a solution of the equation in the region R in order to find a continuation of the curve D. No physically admissible solution has been found so far, at least. This problem is currently under further investigation by the Antenna Laboratory at the University of Illinois. In effect then, except for the solution designated by C in Figure 3a, no complex solution has been found to date even after a fairly thorough search with the computer.

3.2 Interpretation of Theoretical k - β Diagram

The interpretation of the k - β diagram for the corrugated structure considered above is fairly simple. The solid curves in Figure 3a represent surface wave type of solutions. The only complex solutions found are represented by the vertical line at $\beta = \pi$. It may be shown that this solution has the same

character as the filter type attenuated mode in a closed structure. Theoretically, for an infinite structure, there is no radiation from the fields described by this mode solution. Lack of other complex solutions of the determinantal equation must not be so interpreted as to mean that the structure has no radiation. The continuous spectrum of spatial frequencies is always present when one is considering a source problem. In this particular case, a convenient alternate representation for what may be a majority portion of the fields in terms of other complex solutions was unable to be found. In any event, this structure is not expected to produce primarily backfire pattern, one of the criteria which was set forth as desirable. Complex solutions with a leading phase constant β , and which produce fields that couple fairly effectively to space is what we are seeking. A possible modification which will make it possible to realize such a characteristic is discussed in the following section.

3.3 Modification for Realizing a Backfire Condition

Consider the modification that results in the k - β diagram of the corrugated structure when it is coupled to another system which has its k - β diagram shown by the line B in Figure 4. If these two systems couple effectively near I, complex solutions will result (for details on coupled mode theory see Louisell⁸) in the neighborhood of the point of intersection of the unperturbed solutions associated with the two systems. Since the location of I is in the leading phase region, backfire patterns will be expected. For lower frequencies when the two unperturbed solutions are far apart, modification of the solutions due to coupling will be small and two different mode solutions will be expected. It is not possible to say without solving the source problem what the relative amplitude of excitations of these two mode amplitudes will be. One would expect though that there will be regions where the solution A will be predominant and some others where the influence of B will be larger. Where A dominates, the patterns will be primarily endfire whereas backfire radiation will be expected in regions where the composite solution is closer to B. One expects the solution B to dominate in the vicinity of the point I (see Figure 4) for waves traveling in the positive direction. A straightforward system which will produce a k - β characteristic of the type B is shown in Figure 5. The picture shows a transmission line loaded periodically with series loops which alternate in their sense of winding. Assuming the current flows along the loops at

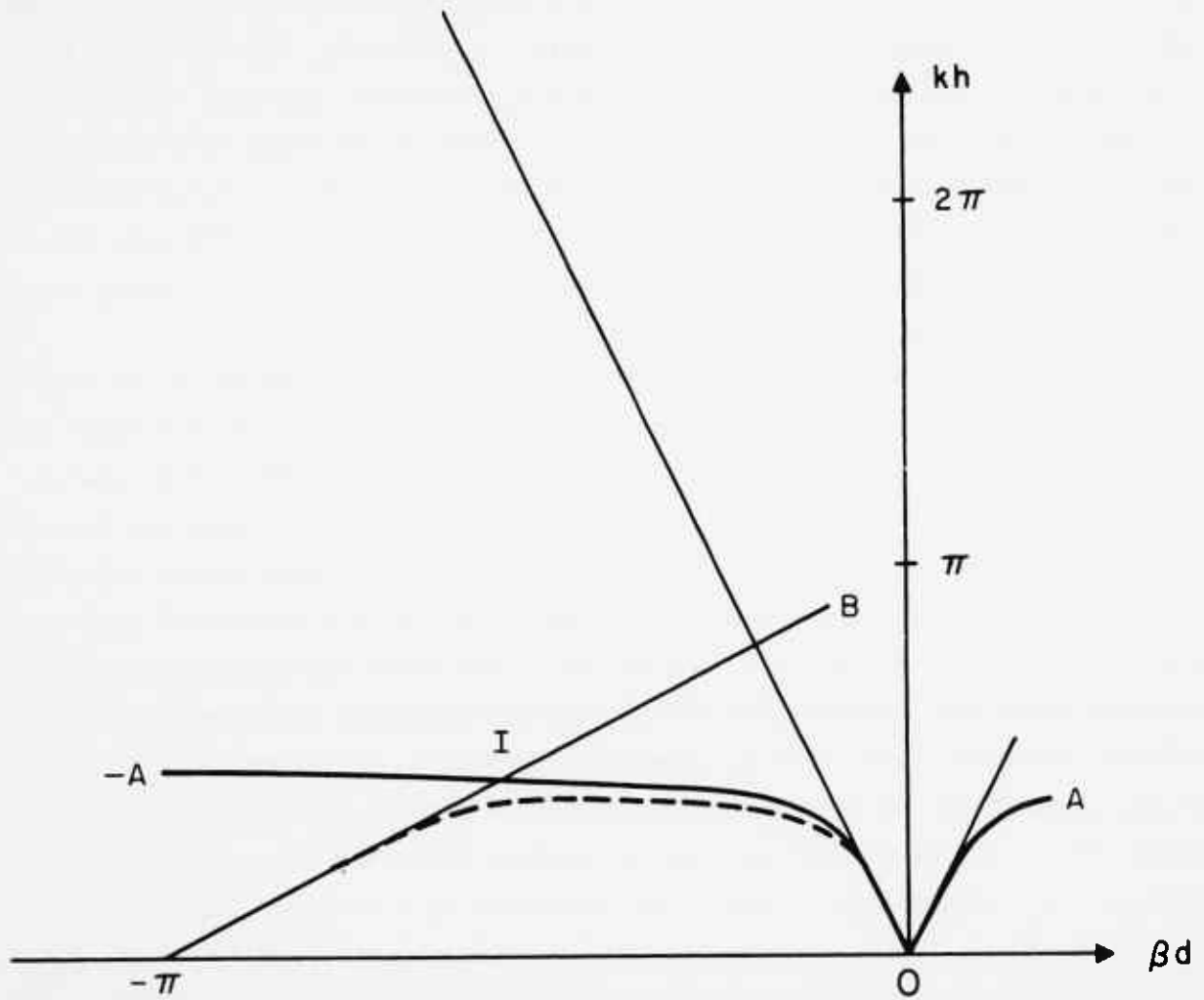

Figure 4. $k-\beta$ Diagram Showing Coupling of Modes



Figure 5. Transmission Line Periodically Loaded with Alternately Transposed Loops

velocity of light one expects the slope of the curve B to be smaller than 1 and the limiting value of β as $k \rightarrow 0$ to be π . This is the type of characteristic we have been looking for. A coupled system is shown in Figure 6. Next are the experimental measurements on the corrugated surface and the coupled system and finally the wide-band corrugated surface antenna.

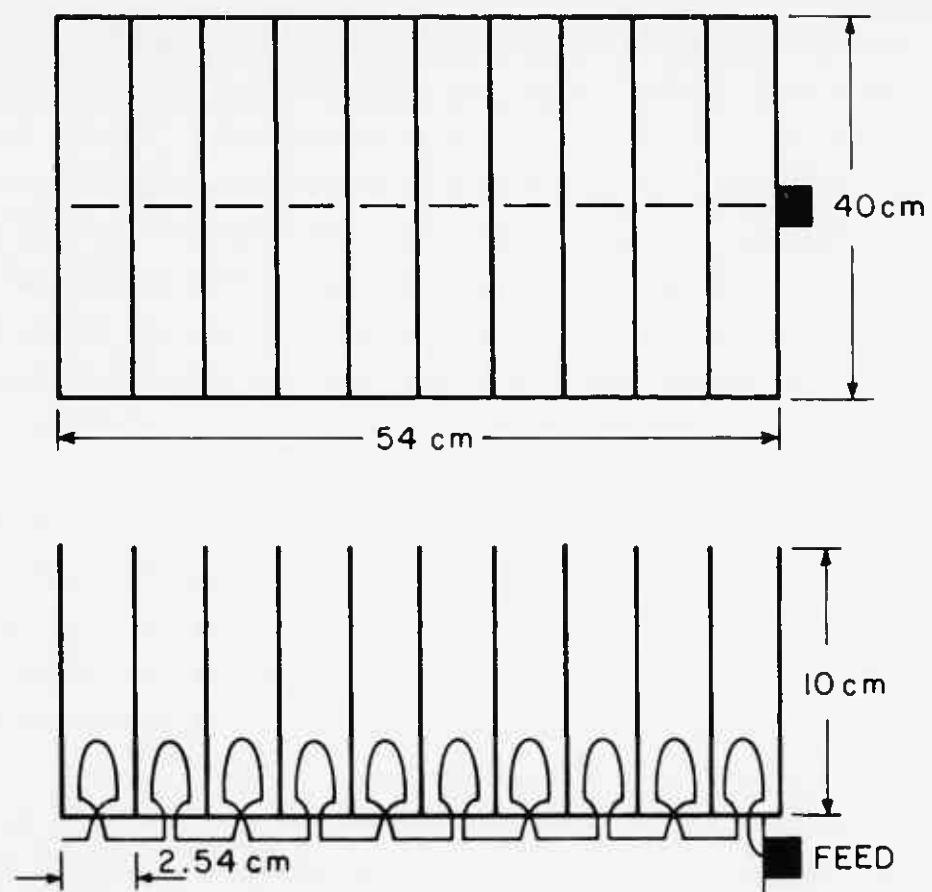

Figure 6. Uniform Letter-Rack Antenna
21 Cavities
Slot Depth $\lambda/4$ at 750 MC

4. EXPERIMENTAL RESULTS

4.1 The Corrugated Surface

The uniform corrugated surface was made by stacking 2" x 10" aluminum plates. The bottom of the troughs was also aluminum. A sketch of this structure is shown in Figure 3 along with other details. After considering various possible feeds, such as a horn or single wire exciter, it was decided to use a single loop feed at one end of the structure. This feed showed fairly efficient coupling to the structure when it was placed near the bottom of the first trough and yet had little direct contribution to the far field.

An automatic plotter was used to plot the near field amplitude of the H_x -field as a function of distance along the structure. The probe and the antenna were placed in an anechoic chamber.

In the frequency range where there is little attenuation of the wave supported by the structure, it is convenient to measure β by putting a large shorting plane on the end of the structure and setting up standing waves on the surface. The guide half-wavelength ($\lambda_g/2$) can be determined by measuring the distance between two minimas. The measured values of $\beta d = 2\pi d/\lambda_g$ are plotted in Figure 3 as a function of kh .

At low frequencies the experimental points are quite close to the theoretical curve and the attenuation of the wave is negligible. Only near the turnover point P does the attenuation become noticeable.

Above the turnover point the experimental curve tends to turn back toward smaller values of β instead of following along the line $\beta = \pi$ which was calculated theoretically. One possible explanation for this is the following.

In the frequency range above the turnover point, the fields due to a given source must be described by including the spatial frequencies which have a continuous spectrum. The small frequency range above the turnover point is a sort of transition region between the surface wave mode and continuous spectrum type of behavior. In this region the values can be approximately tracked up to a certain frequency beyond which no meaningful measurements could be made until the next mode is reached. The next mode, corresponding to a cosine distribution in the transverse direction, has surface wave propagation until its turnover point is reached.

The possibility of the existence of another complex solution of the characteristic equation which will correspond to the experimentally measured point is currently being investigated at the Antenna Laboratory of the University of Illinois.⁹ However this question still remains open.

So far, the experimental measurements and experimental far field patterns have not convincingly demonstrated such a solution.

4.2 Uniform Version of the Corrugated Surface with Multiple Loop Feed

A uniform version of the corrugated surface antenna, i.e., one with $\tau = 1$, was built and studied in order to gain an insight into the behavior of its LP counterpart.

The uniform version was constructed by bolting aluminum plates with right angle bends to a sheet of aluminum. Holes drilled in the center of the bottom of each slot allowed the feed cable to pass in and out of each slot. The loops were formed by the feed cable held in place by polyfoam spacers and every other loop was wound in the opposite direction. The tops of the plates were spaced by pieces of plexiglass. The dimensions of this model are shown in Figure 6.

A Rohde and Schwarz diagraph was used to measure near field phase and amplitude of the H_x field over each cell. Again, the field probe and the antenna were placed in an anechoic chamber.

The experimental results in Figure 7 show $\frac{kd}{2\pi}$ versus normalized phase shift per cell $\frac{\beta d}{2\pi}$. In the region kd below .035, the points indicate a wave traveling down the feed wire, mode B, with slowness of about 13.5, whereas the slowness expected if the current were assumed to be traveling along the wire with free space velocity would be 11. This could be explained by noting an additional loading effect on the feed line due to its close proximity to the corrugated surface. The coupling at point I has been discussed previously. Far field measurements at these frequencies show a backfire type of pattern, as shown in Figure 8.

At higher values of kd the experimental points follow the curve +A. Corresponding far fields measurements show an endfire type of pattern.

A higher order mode appears to dominate at even higher kd values giving a far field pattern which is split or double lobed in the aperture plane (see Figure 8).

THEORETICAL ASYMTOTES ———
LOOP STRUCTURE - - - - -
EXPERIMENTAL POINTS ⊙

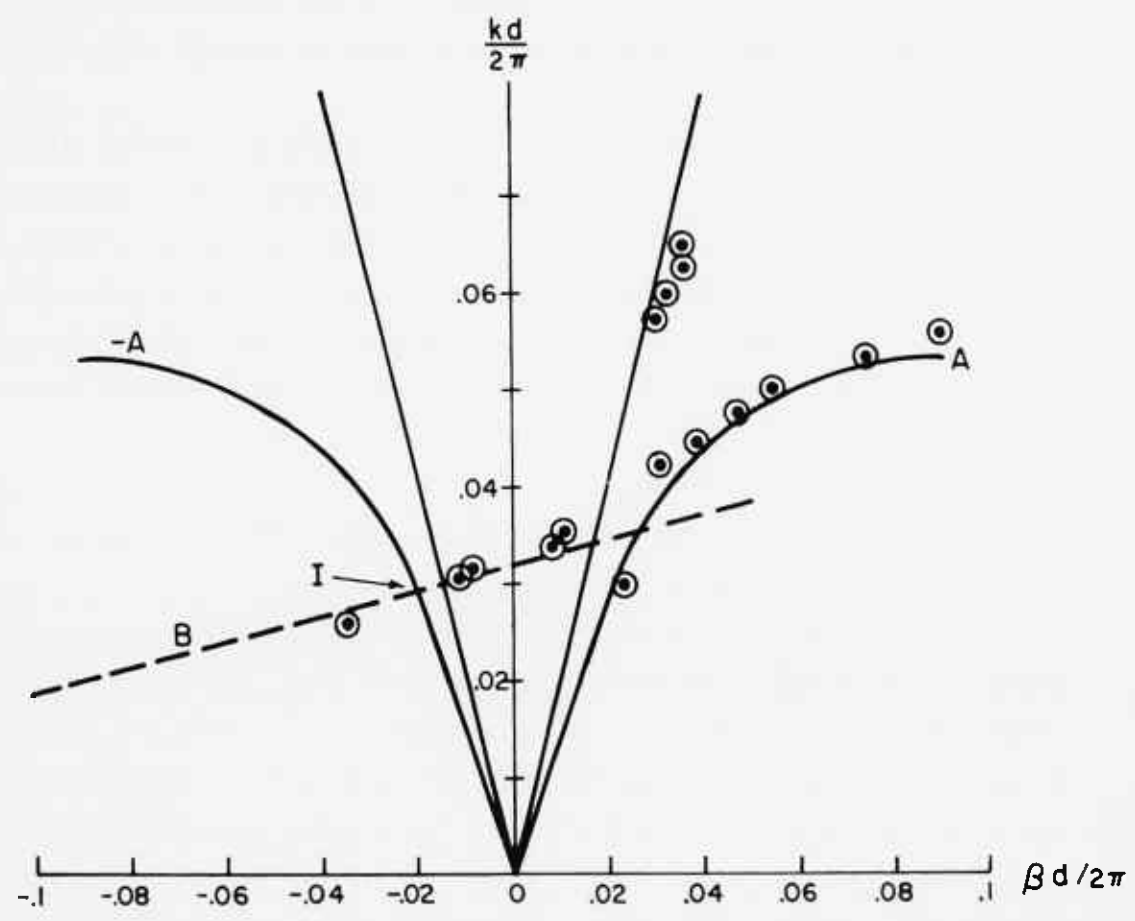

Figure 7. K - β Diagram of Uniform Corrugated Surface with Multiple Loop Feed

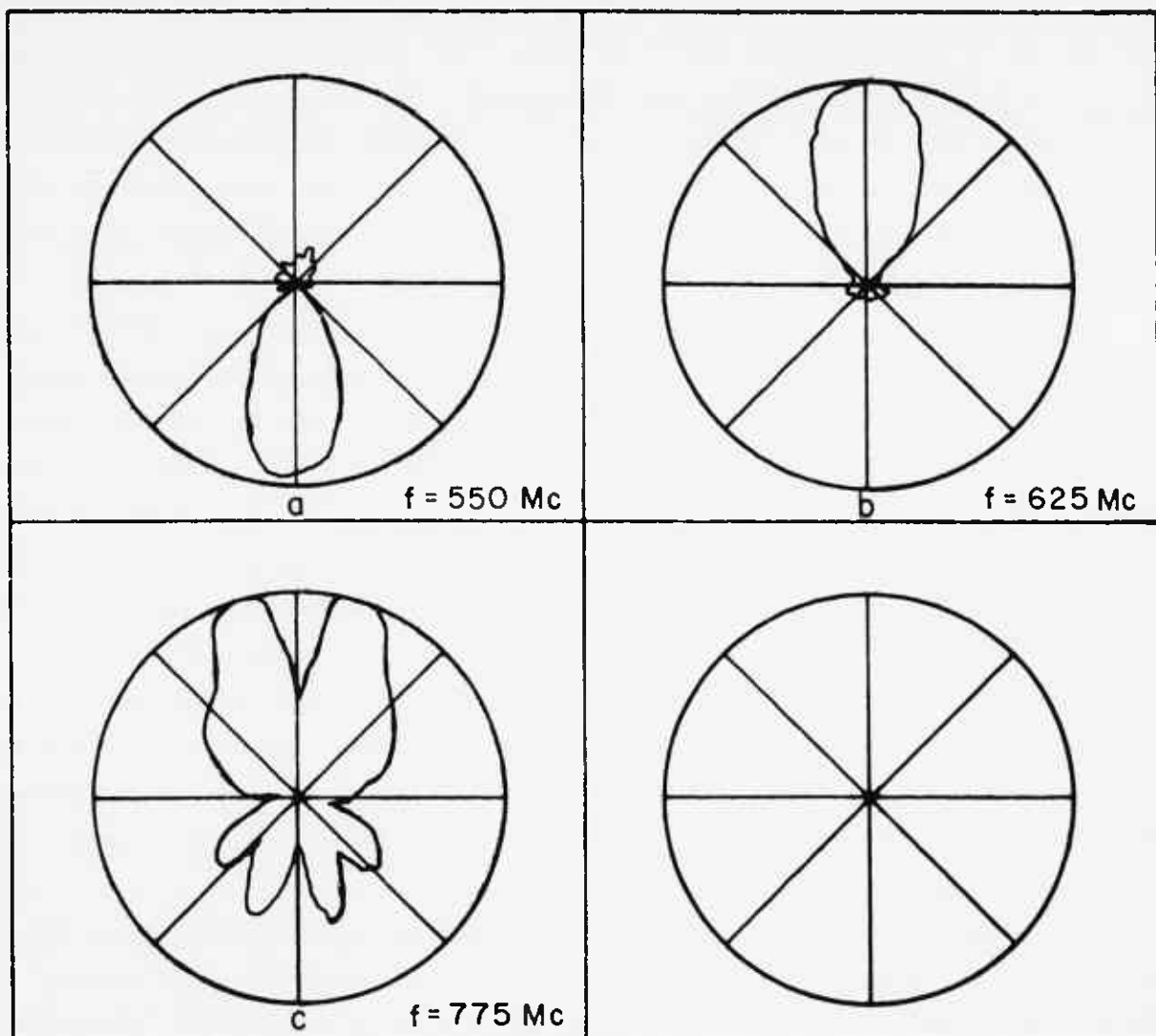

Figure 8. Three Patterns of the Uniform Letter-Rack Antenna

From this information, it can be predicted that the LP version should work satisfactorily if radiation due to mode +A and higher order modes is small and if the effective radiation comes from the coupled curves B and -A.

4.3 The Wide-Band Corrugated Surface Antenna

The LP corrugated surface with multiple feed was constructed in the same manner as the uniform version except all dimensions were scaled by a factor τ from cell to cell. A sketch of this structure is shown in Figure 9.

A typical near field amplitude plot of the transverse H-field as a function of distance along the structure is shown in Figure 10. Note that the wave is fairly well bound at the input end of the antenna but becomes more and more loosely attached to the surface as it approaches the active region where the field amplitude reaches a maximum. The H_x field decays very rapidly beyond this point, and there is no significant energy left at the end of the structure. The near field phase measurements show a leading phase distribution in regions where the amplitude is significant. This indicates mode B is predominant in most of the regions of interest, and hence the LP structure produces a predominately backfire pattern. The near field measurements also scale fairly well with frequency indicating a broadband performance. The H-field behavior measured on this structure shows a strong resemblance to the current distribution at the base of the dipoles in the log-periodic dipole array, as reported by Carrel.¹⁰

A larger model of the wide-band corrugated surface antenna to fit into a 30in. Circular aperture was built for impedance measurements. The spacing away from ground or feedline from loop to loop was left variable. The impedances of this antenna over its design range are shown in Figure 11. The points shown were taken with the feedline very close to the bottom plate of the antenna which is grounded.

A predominately backfire type of pattern over a wide range of frequencies is exhibited by the far-field measurements on the wide-band corrugated surface, the Letter-rack antenna.¹¹ These are shown in Figure 12. Note that low frequency performance extends down to 500 mcs, whereas the frequency at which the last slot becomes a quarter wavelength is above 850 mcs. This may be explained by going back to the coupled mode approach discussed earlier. Referring back to Figure 4, if there is a strong interaction between the corrugated surface and the loop structure, i.e., between curves -A and B, the resulting curve will

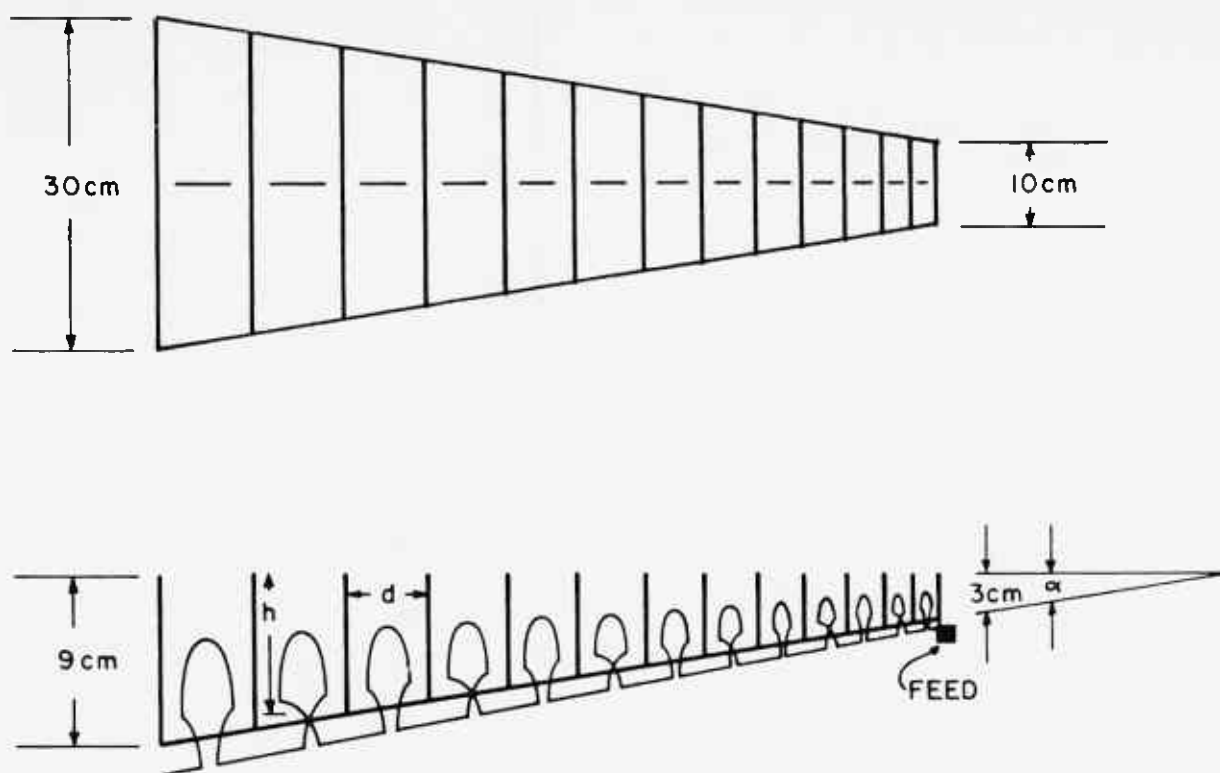

Figure 9. The LP Letter-Rack Antenna

Last Slot is $\lambda/4$ at 850 MC

$\tau = .97$

$h/d = 4.5/1$

37 Elements

$\alpha = 9^\circ$

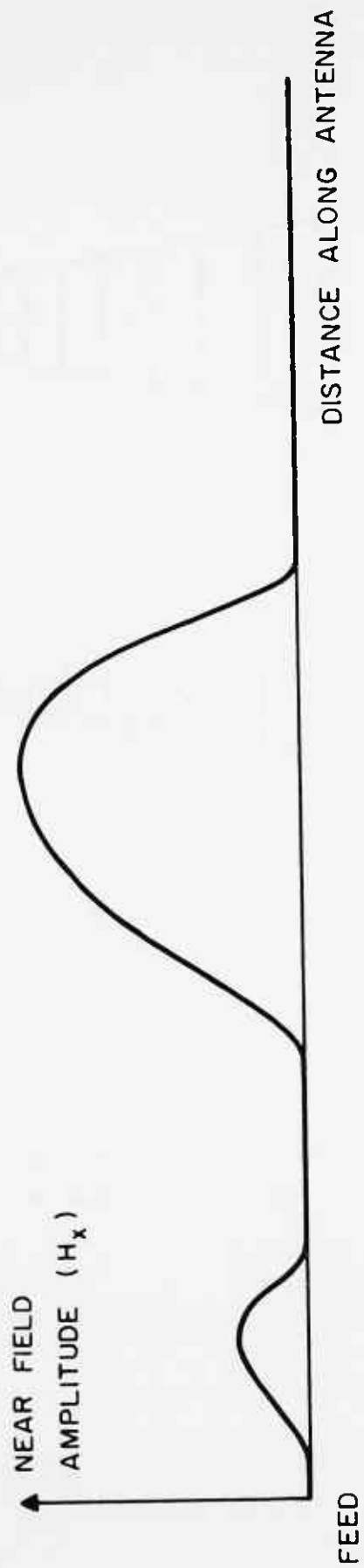

L.P. LETTER RACK

$f = 700 \text{ MC}$

Figure 10. Typical Near Field Amplitude of the Log-Periodic Letter-Rack Antenna

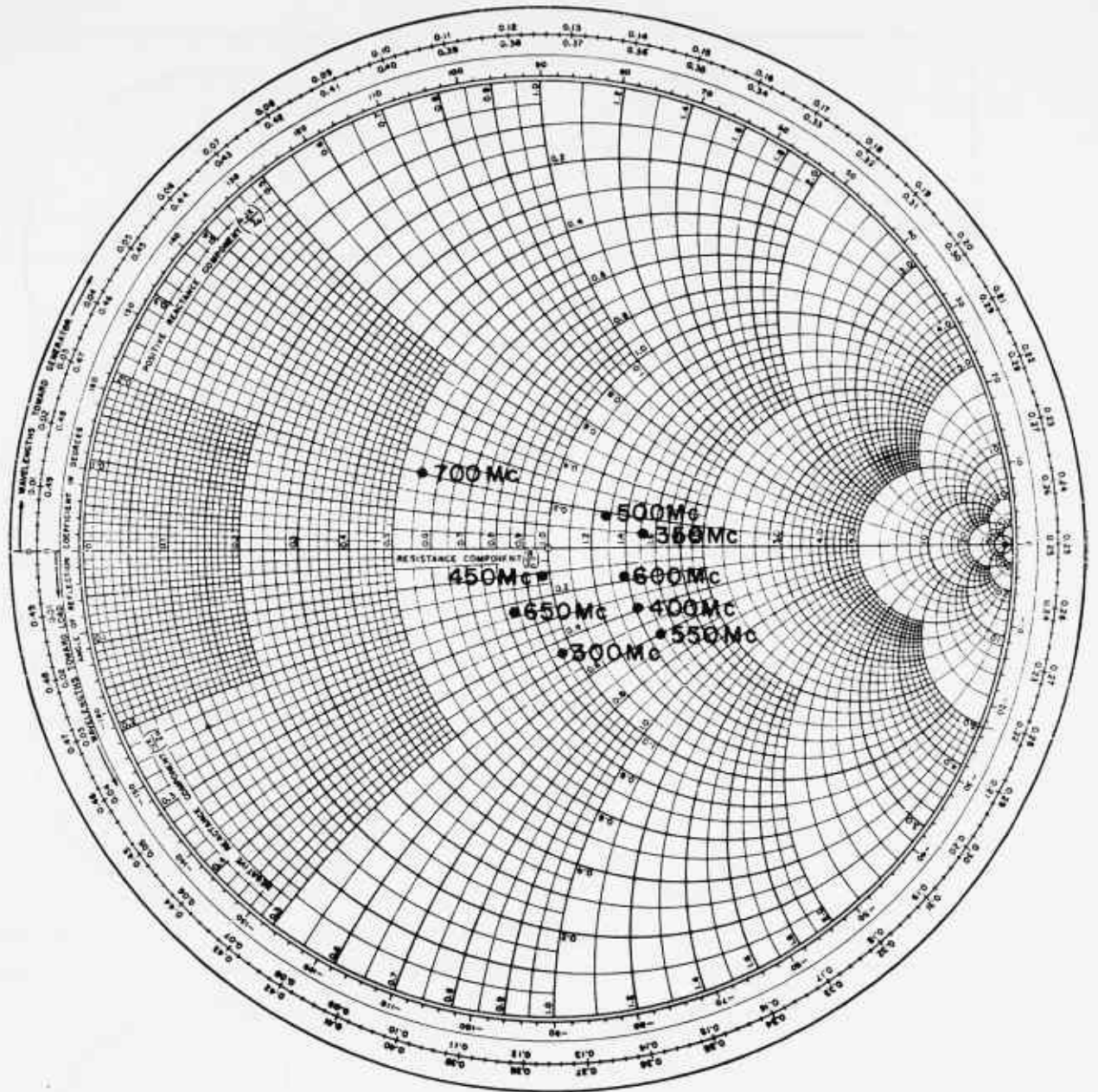

Figure 11. Impedance of a Wide-band Corrugated Surface Antenna

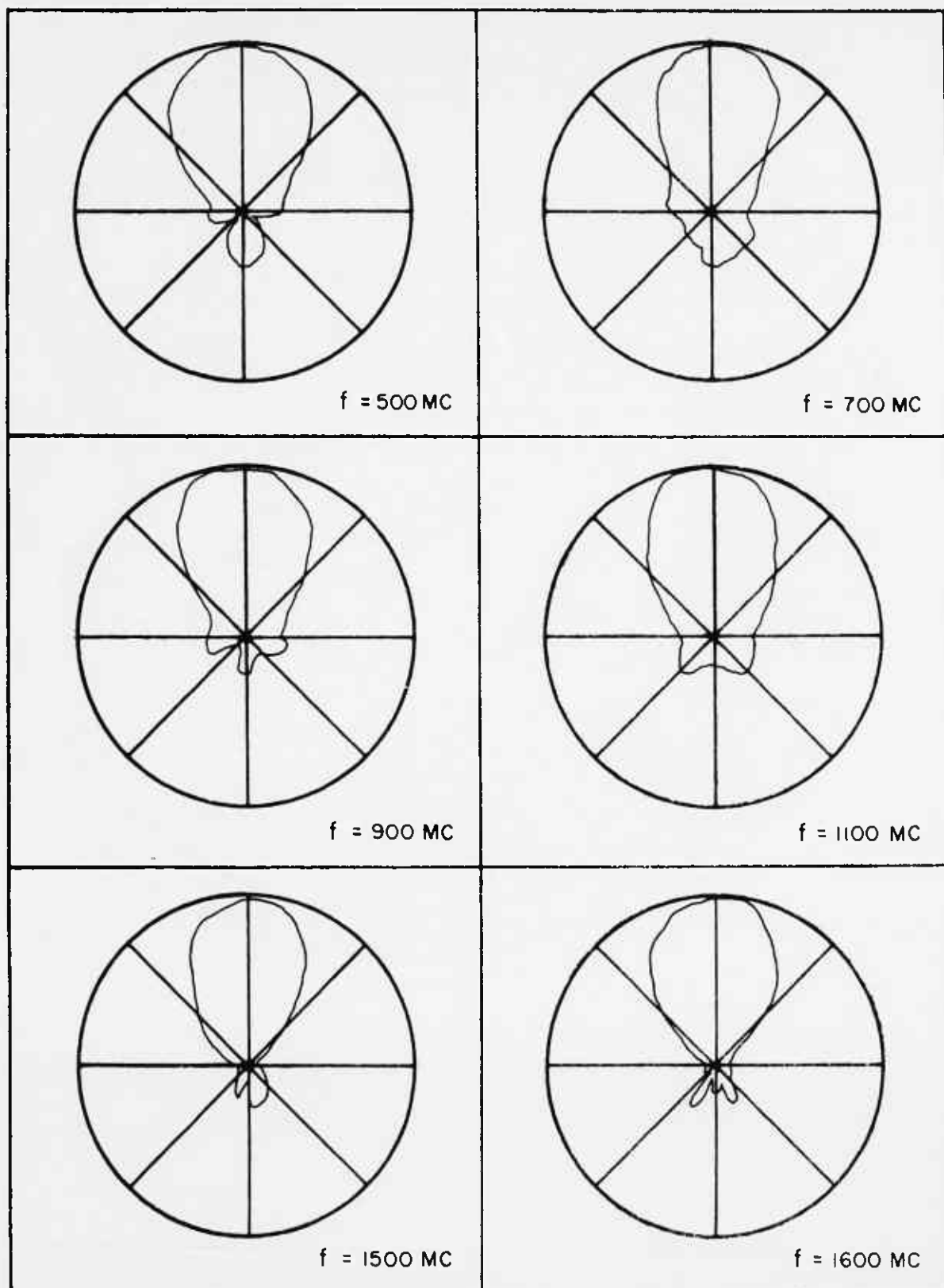

Figure 12. Far Field Patterns of the Log-Periodic Letter-Rack Antenna

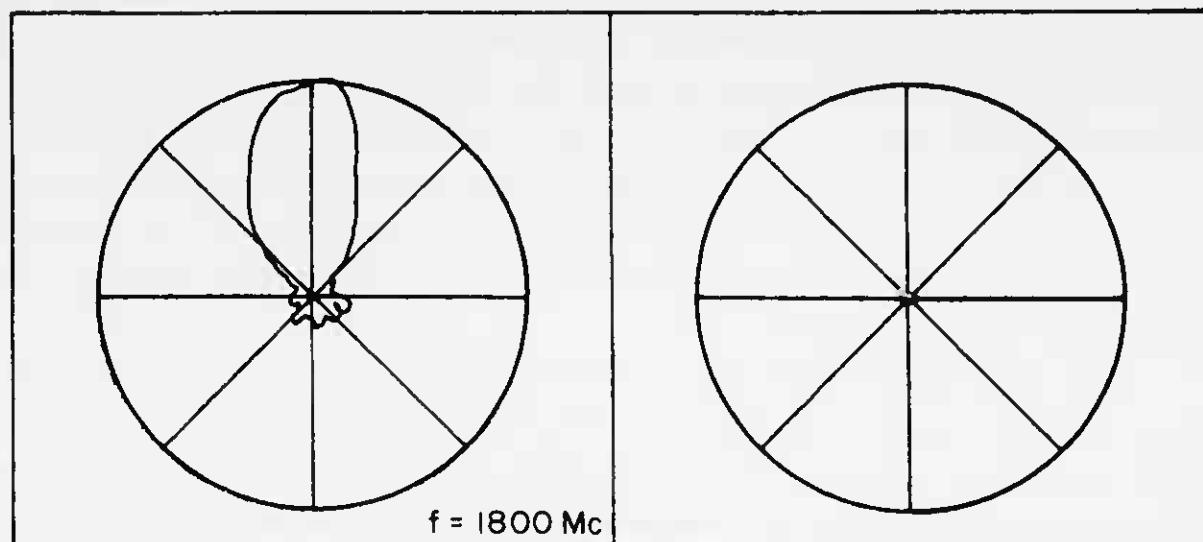

Figure 12a (cont'd). A Far-Field Pattern of the Log-Periodic Letter-Rack Antenna

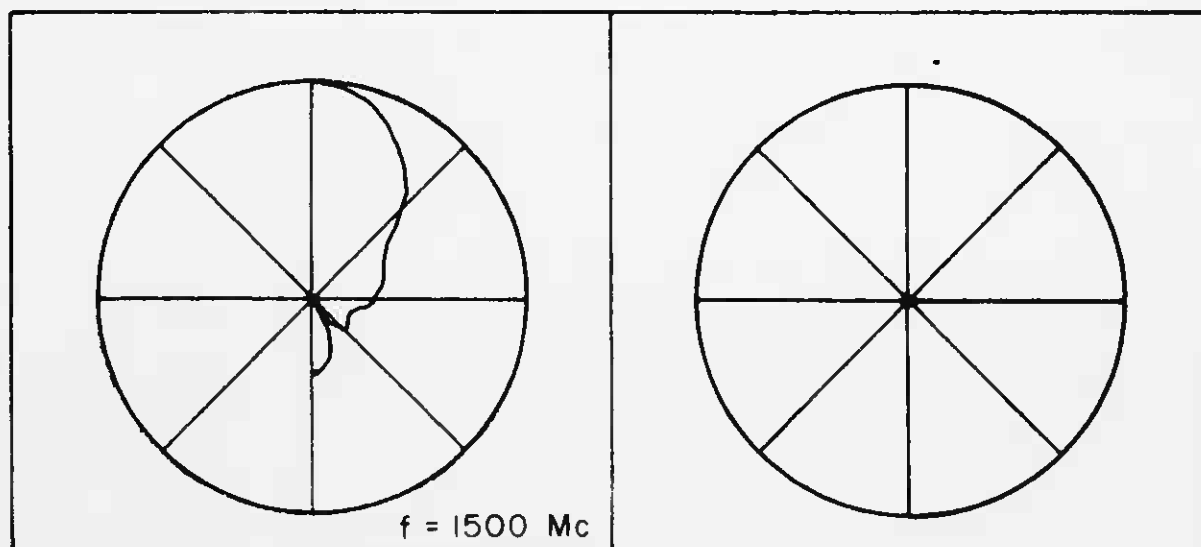

Figure 12b. Typical Far-field Pattern (E Plane) of LP Letter-Rack Antenna

have a turnover point considerably lower than the frequency corresponding to the point I. As a consequence of this, the frequency at which the slots start attenuating the wave will lower the point I. Also note that the point I could be substantially lower than the turnover point of curve A depending on the slope of curve B. Hence the usable low frequency limit of the antenna will be considerably lower than that predicted by the quarter wave resonance frequency of the largest slot.

The above behavior is tied up with the strength of interaction between the corrugated surface and the feed structure and the predominance of mode B with desired attenuation. If the loops are made very small, the performance of the antenna deteriorates considerably. The bandwidth becomes narrower, the front-to-back ratio becomes smaller, and the standing wave ratio at the input increases as a result. These can be attributed to the presence of the undesired mode, i.e., mode +A, in the radiation region, weak coupling between -A and B resulting in lower attenuation along the structure for the complex wave and hence larger end effect, and poor conversion of the transmission wave into the radiating wave and hence larger reflected wave toward the feed. Therefore, it is quite important to design the antenna in such a manner as to insure coupling between the corrugated surface and the loop structure.

5. CONCLUSION

It was shown why the simple corrugated surface is not suitable for broadband design without some basic changes. A composite system consisting of a series of alternately transposed loops and the corrugated surface was constructed such that the two periodic systems couple strongly to each other. Then a tapered version, a wide-band flush-mounted antenna, also called the Letter-rack antenna,¹¹ was designed from the previously gained knowledge. The behavior of the coupled system was studied on the basis of coupled mode theory. The significance of the k - β diagram to the LP antenna design was also outlined. The purpose of this project was not to design a particular piece of hardware for a particular job, but to outline certain principles which might help in understanding the behavior of a class of LP antennas and to design some new ones on the basis of this understanding. Another successful antenna, a series-loaded folded dipole structure shown in Figure 13, has been built following these principles.

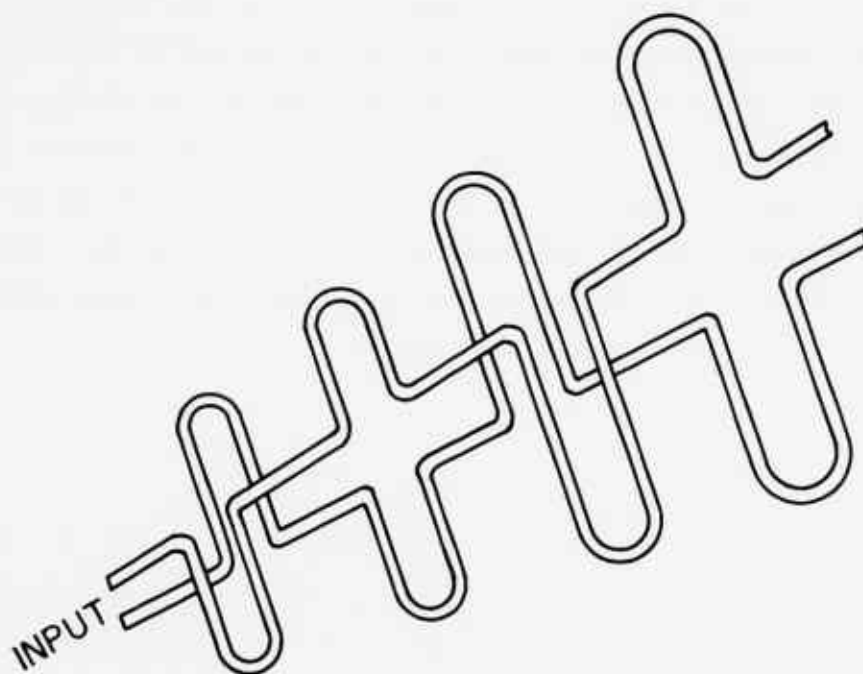

Figure 13. Log-Periodic Folded Dipole Array

BIBLIOGRAPHY

1. P. E. Stang, "Balanced Flush Mounted Log-Periodic Antennas for Aerospace Vehicles," Twelfth Annual Symposium on the USAF Antenna Research and Development Program, Robert Allerton Park, University of Illinois, October 1962.
2. P. E. Mayes, G. A. Deschamps, W. T. Patton, "Backward-Wave Radiation from Periodic Structures and Application to the Design of Frequency-Independent Antennas," Proc. IRE, Vol. 49, No. 5, May 1961.
3. A. A. Oliner and A. Hessel, "Guided Waves on Sinusoidally-Modulated Reactance Surfaces," Trans. IRE, Vol. AP-7, pp. S201-S208, December 1959.
4. L. Brillouin, "Wave Guides for Slow Waves," Journal of Applied Physics, Vol. 19, pp. 1023-1041, November 1948.
5. R. A. Hurd, "The Propagation of an Electromagnetic Wave Along an Infinite Corrugated Surface," Canadian Journal of Physics, Vol. 32, No. 12, December 1954.
6. R. Mittra, "The Finite Range Wiener-Hopf Integral Equation," Trans. IRE, Vol. AP-7, pp. S244-S254, December 1959.
7. T. Muir, "A Treatise on the Theory of Determinants," Dover, New York, 1960.
8. W. H. Louisell, "Coupled Mode and Parametric Electronics," John Wiley & Sons, Inc., 1960.
9. R. Mittra and S. Laxpati, Private Communication.
10. R. L. Carrel, "Analysis and Design of the Log-Periodic Dipole Antenna," Antenna Laboratory Technical Report No. 52, University of Illinois, Urbana, Illinois.
11. R. Mittra and M. L. Wahl, "The Letter-Rack Antenna--A Wide-Band Flush-Mounted Antenna of Log-Periodic Design," Convention Record, First IEEE International Convention, New York, 1963.

ANTENNA LABORATORY

TECHNICAL REPORTS AND MEMORANDA ISSUED

Contract AF33(616)-310

"Synthesis of Aperture Antennas," Technical Report No. 1, C. T. A. Johnk, October, 1954. * AD-52134.

"A Synthesis Method for Broadband Antenna Impedance Matching Networks," Technical Report No. 2, Nicholas Yaru, 1 February 1955. * AD 61049.

"The Assymmetrically Excited Spherical Antenna," Technical Report No. 3, Robert C. Hansen, 30 April 1955. * AD-66220.

"Analysis of an Airborne Homing System," Technical Report No. 4, Paul E. Mayes, 1 June 1955 (CONFIDENTIAL). AD-80147.

"Coupling of Antenna Elements to a Circular Surface Waveguide," Technical Report No. 5, H. E. King and R. H. DuHamel, 30 June 1955. * AD-75733.

"Input Impedance of a Spherical Ferrite Antenna with A Latitudinal Current," Technical Report No. 6, W. L. Weeks, 20 August 1955. AD-75732.

"Axially Excited Surface Wave Antennas," Technical Report No. 7, D. E. Royal, 10 October 1955. * AD-75731.

"Homing Antennas for the F-86F Aircraft (450-2500 mc), Technical Report No. 8, P. E. Mayes, R. F. Hyneman, and R. C. Becker, 20 February 1957.

"Ground Screen Pattern Range," Technical Memorandum No. 1, Roger R. Trapp, 10 July 1955. *

Contract AF33(616)-3220

"Effective Permeability of Spheroidal Shells," Technical Report No. 9, E. J. Scott and R. H. DuHamel, 16 April 1956. AD-98615.

"An Analytical Study of Spaced Loop ADF Antenna Systems," Technical Report No. 10, D. G. Berry and J. B. Kreer, 10 May 1956.

"A Technique for Controlling the Radiation from Dielectric Rod Waveguides," Technical Report No. 11, J. W. Duncan and R. H. DuHamel, 15 July 1956. * AD-107344.

"Direction Characteristics of a U-Shaped Slot Antenna," Technical Report No. 12, Richard C. Becker, 30 September 1956. * AD-116104.

"Impedance of Ferrite Loop Antennas," Technical Report No. 13, V. H. Rumsey and W. L. Weeks, 15 October 1956. ** AD 119780.

- "Closely Spaced Transverse Slots in Rectangular Waveguide," Technical Report No. 14, Richard F. Hyneman, 20 December 1956. ** AD-127455.
- "Distributed Coupling to Surface Wave Antennas," Technical Report No. 15, R. R. Hodges, Jr., 5 January 1957. ** AD-127454.
- "The Characteristic Impedance of the Fin Antenna of Infinite Length," Technical Report No. 16, Robert L. Carrel, 15 January 1957. *AD-127453.
- "On the Estimation of Ferrite Loop Antenna Impedance," Technical Report No. 17, Walter L. Weeks, 10 April 1957. **AD-143989.
- "A Note Concerning a Mechanical Scanning System for a Flush Mounted Line Source Antenna," Technical Report No. 18, Walter L. Weeks, 20 April 1957. * AD-143990.
- "Broadband Logarithmically Periodic Antenna Structures," Technical Report No. 19, R. H. DuHamel and D. E. Isbell, 1 May 1957. AD-140734.
- "Frequency Independent Antennas," Technical Report No. 20, V. H. Rumsey, 25 October 1957. AD-153260.
- "The Equiangular Spiral Antenna," Technical Report No. 21, J. D. Dyson, 15 September 1957. * AD-145019.
- "Experimental Investigation of the Conical Spiral Antenna," Technical Report No. 22, R. L. Carrel, 25 May 1957. ** AD-144021.
- "Coupling between a Parallel Waveguide and a Surface Waveguide," Technical Report No. 23, E. J. Scott, 10 August 1957. AD-144030.
- "Launching Efficiency of Wires and Slots for a Dielectric Rod Waveguide," Technical Report No. 24, J. W. Duncan and R. H. DuHamel, August 1957. AD-144030.
- "The Characteristic Impedance of an Infinite Biconical Antenna of Arbitrary Cross Section," Technical Report No. 25, Robert L. Carrel, August 1957. AD-144121.
- "Cavity-Backed Slot Antennas," Technical Report No. 26, R. J. Tector, 30 October 1957. AD-149451.
- "Coupled Waveguide Excitation of Traveling Wave Slot Antennas," Technical Report No. 27, W. L. Weeks, 1 December 1957. AD-155178.
- "Phase Velocities in Rectangular Waveguide Partially Filled with Dielectric," Technical Report No. 28, W. L. Weeks, 20 December 1957. AD-155177.
- "Measuring the Capacitance per Unit Length of Biconical Structures of Arbitrary Cross Section," Technical Report No. 29, J. D. Dyson, 10 January 1958. AD-153561.
- "Non-Planar Logarithmically Periodic Antenna Structure," Technical Report No. 30, D. E. Isbell, 20 February 1958. * AD-156203.

"Electromagnetic Fields in Rectangular Slots," Technical Report No. 31, N. J. Kuhn and P. E. Mast, 10 March 1958. AD-156709.

"The Efficiency of Excitation of a Surface Wave on a Dielectric Cylinder," Technical Report No. 32, J. W. Duncan, 25 May 1958. AD-162052.

"A Unidirectional Equiangular Spiral Antenna," Technical Report No. 33, J. D. Dyson, 10 July 1958.* AD-201138.

"Dielectric Coated Spheroidal Radiators," Technical Report No. 34, W. L. Weeks, 12 September 1958. AD-204547.

"A Theoretical Study of the Equiangular Spiral Antenna," Technical Report No. 35, P. E. Mast, 12 September 1958.**AD-204548.

Contract AF33(616)-6079

"Use of Coupled Waveguides in a Traveling Wave Scanning Antenna," Technical Report No. 36, R. H. MacPhie, 30 April 1959. AD-215558.

"On the Solution of a Class of Wiener-Hopf Integral Equations in Finite and Infinite Ranges," Technical Report No. 37, R. Mittra, 15 May 1959.**AD-220543.

"Prolate Spheroidal Wave Functions for Electromagnetic Theory," Technical Report No. 38, W. L. Weeks, 5 June 1959.* AD-226727.

"Log Periodic Dipole Arrays," Technical Report No. 39, D. E. Isbell, 1 June 1959.**AD-220651.

"A Study of the Coma-Corrected Zoned Mirror by Diffraction Theory," Technical Report No. 40, S. Dasgupta and Y. T. Lo, 17 July 1959.* AD-225273.

"The Radiation Pattern of a Dipole on a Finite Dielectric Sheet," Technical Report No. 41, K. G. Balmain, 1 August 1959.

"The Finite Range Wiener-Hopf Integral Equation and a Boundary Value Problem in a Waveguide," Technical Report No. 42, R. Mittra, 1 October 1959.**AD-229279.

"Impedance Properties of Complementary Multiterminal Planar Structures," Technical Report No. 43, G. A. Deschamps, 11 November 1959. AD-230625.

"On the Synthesis of Strip Sources," Technical Report No. 44, R. Mittra, 4 December 1959. AD-230624.

"Numerical Analysis of the Eigenvalue Problem of Waves in Cylindrical Waveguides," Technical Report No. 45, C. H. Tang and Y. T. Lo. 11 March 1960. AD-234536.

"New Circularly Polarized Frequency Independent Antennas with Conical Beam or Omnidirectional Patterns," Technical Report No. 46, J. D. Dyson and P. E. Mayes, 20 June 1960. *AD-241321.

"Logarithmically Periodic Resonant-V Arrays," Technical Report No. 47, P. E. Mayes and R. L. Carrel, 15 July 1960.**AD-246302.

"A Study of Chromatic Aberration of a Coma-Corrected Zoned Mirror," Technical Report No. 48, Y. T. Lo, June 1960. AD-252492.

"Evaluation of Cross-Correlation Methods in the Utilization of Antenna Systems," Technical Report No. 49, R. H. MacPhie, 25 January 1961. AD-252493.

"Synthesis of Antenna Products Patterns Obtained from a Single Array," Technical Report No. 50, R. H. MacPhie, 25 January 1961. AD-252494.

"On the Solution of a Class of Dual Integral Equations," Technical Report No. 51, R. Mittra, 1 October 1961. AD-264557.

"Analysis and Design of the Log-Periodic Dipole Antenna," Technical Report No. 52, Robert L. Carrel, 1 October 1961. AD-264558.

"A Study of the Non-Uniform Convergence of the Inverse of a Doubly-Infinite Matrix Associated with a Boundary Value Problem in a Waveguide," Technical Report No. 53, R. Mittra, 1 October 1961. AD-264556.

Contract AF33(616)-8460

"The Coupling and Mutual Impedance Between Balanced Wire-Arm Conical Log-Spiral Antennas," Technical Report No. 54, J. D. Dyson, June 1962. AD-285678.

"An Investigation of the Near Fields on the Conical Equiangular Spiral Antenna," Technical Report No. 55, O. L. McClelland, May 1962. AD-276463.

"Input Impedance of Some Curved Wire Antennas," Technical Report No. 56, C. H. Tang, June 1962. AD-276461.

"Polygonal Spiral Antennas," Technical Report No. 57, C. H. Tang, O. L. McClelland, June 1962.

"On Increasing the Effective Aperture of Antennas by Data Processing," Technical Report No. 58, R. H. MacPhie, July 1962.**

"Theoretical Study of a Class of Logarithmically Periodic Circuits," Technical Report No. 59, R. Mittra, July 1962.* AD-282847.

"Backward Wave Radiation from Periodic Structures and Application to the Design of Frequency-Independent Antennas," Technical Report No. 60, P. E. Mayes, G. A. Deschamps, and W. T. Patton, December 1962. AD-291765.

"The Backfire Bifilar Helical Antenna," Technical Report No. 61, W. T. Patton, September 1962. AD-289084.

"On the Mapping by a Cross-Correlation Antenna System of Partially Coherent Radio Sources" Technical Report No. 62, R. H. MacPhie, October 1962. AD-289085.

"On a Conical Quad-Spiral Array", Technical Report No. 63, J. D. Dyson, September 1961. AD-288252.

"Antenna Impedance Matching by Means of Active Networks," Technical Report No. 64, S. Laxpati, R. Mitra, November 1962. AD-291766.

Contract AF33(657)-10474

"On Maximizing the Signal-To-Noise Ratio of a Linear Receiving Antenna Array," Technical Report No. 65, R. H. MacPhie, January 1963.

"Application of Cross-Correlation Techniques to Linear Antenna Arrays", Technical Report No. 67, R. H. MacPhie, March 1963.

"A Study of Wave Propagation of Helices", Technical Report No. 68, Paul W. Klock, March 1963.

"Relative Convergence of the Solution of a Doubly Infinite Set of Equations," Technical Report No. 69 R. Mitra, April 1963.

"Theoretical Brillouin (k - B) Diagram for Monopole and Dipole Arrays and Their Application to Log-Periodic Antennas," Technical Report No. 70, R. Mitra and K. E. Jones, April 1963.

* Copies available for a three-week loan period

** Copies no longer available

DISTRIBUTION LISTOne copy each unless otherwise indicated

Armed Services Technical Information Agency Attn: TJP-DR Arlington Hall Station Arlington 12, Virginia (20 copies)	Commander Foreign Technology Division Attn: TD-E1 Wright-Patterson Air Force Base Ohio
Air Force Systems Command (SCSE) Andrews Air Force Base Washington 25, D. C.	Air Force Cambridge Research Laboratory Attn: CRRD Laurence G. Hanscom Field Bedford, Massachusetts
Aeronautical Systems Division Attn: ASRNCF-3 Wright-Patterson Air Force Base Ohio (5 copies)	Commander Air Force Missile Test Center Technical Library Patrick Air Force Base Florida
Aeronautical Systems Division Attn: ASNSED, Mr. Mulligan Wright-Patterson Air Force Base Ohio	Commander Air Force Missile Development Center Attn: Technical Library Holloman Air Force Base New Mexico
Aeronautical Systems Division Attn: ASNXRR Wright-Patterson Air Force Base Ohio	Air Force Ballistic Missile Division Attn: Technical Library, Air Force Unite Post Office Los Angeles, California
Aeronautical Systems Division Attn: ASPSA- Library Wright-Patterson Air Force Base Ohio	Commanding Officer USARDVL Attn: SIGPA/SL-NAI Fort Monmouth, New Jersey
Aeronautical Systems Division Attn: ASNPRS Wright-Patterson Air Force Base Ohio	Chief, Bureau of Ships Attn: Code 312 Main Navy Building Washington 25, D. C.
Commander Air Force Systems Command Aeronautical Systems Division Wright-Patterson Air Force Base Ohio Attn: ASNCSO	Commander Air Proving Ground Center (AFSC) Headquarters 3208th Test Group Eglin Air Force Base, Florida
Commander Air Force Systems Command Attn: ASNPOI, Mr. Pinocharo Aeronautical Systems Division Wright-Patterson Air Force Base Ohio	Director Ballistics Research Laboratory Attn: Ballistics Measurement Lab. Aberdeen Proving Ground, Maryland

DISTRIBUTION LIST (continued)
 Contract AF33(657)10474

National Aeronautics & Space Adm.
 Attn: Librarian
 Langley Field, Virginia

Rome Air Development Center
 Attn: RALTM
 Griffiss Air Force Base
 New York

Rome Air Development Center
 Attn: RAWED, Mr. R. F. Davis
 Griffiss Air Force Base
 New York

Commander
 Research & Technology Division
 Attn: RTHE, Maj. J. Gregory
 Bolling Air Force Base
 Washington 25, D. C.

Office of Chief Signal Officer
 Engineering & Technical Division
 Attn: SIGNET-5
 Washington 25, D. C.

Commanding Officer
 U. S. Army Electronics R&D Activity
 Attn: SELWS-ED
 White Sands, Missile Range, New Mexico

Director
 Surveillance Department
 Evans Area
 Attn: Technical Document Center
 Belmar, New Jersey

Commander
 U. S. Naval Air Test Center
 Attn: WSE-54, Antenna Section
 Patuxent River, Maryland

Material Laboratory, Code 932
 New York Naval Shipyard
 Brooklyn 1, New York

Director
 Naval Research Laboratory
 Attn: Code 5200
 Washington 25, D. C.

Director
 Air University Library
 Attn: 3T-AUL-59-30
 Maxwell Air Force Base
 Alabama

Commanding General
 White Sands Missile Range
 Attn: ORDBS-OM-Tech. Library RR-312
 New Mexico

Commanding Officer
 Diamond Ordnance Fuse Laboratories
 Attn: 240
 Washington 25, D. C.

Director
 U. S. Navy Electronics Laboratory
 Attn: Library
 San Diego 52, California

Adams-Russell Company
 280 Bear Hill Road
 Attn: Library (Antenna Section)
 Waltham 54, Massachusetts

Aero Geo Astro
 Attn: Security Officer
 1200 Duke Street
 Alexandria, Virginia

Mr. T. S. Golden
 NASA Goddard Space Flight Center
 Antenna Systems Branch, Code 525
 Greenbelt, Maryland

Airborne Instruments Labs., Inc.
 Attn: Librarian (Antenna Section)
 Walt Whitman Road
 Melville, L. I., New York

American Electronic Labs
 Box 552 (Antenna Section)
 Lansdale, Pennsylvania

Andrew Alfred Consulting Engineers
 Attn: Librarian (Antenna Section)
 299 Atlantic Avenue
 Boston 10, Massachusetts

DISTRIBUTION LIST (continued)
 Contract AF33(657)-10474

Amphenol-Forg Electronic Corporation
 Attn: Librarian (Antenna Section)
 2801 S. 25th Avenue
 Broadview, Illinois

Bell Aircraft Corporation
 Attn: Technical Library
 (Antenna Section)
 Buffalo 5, New York

Bendix Radio Division of
 Bendix Aviation Corporation
 Attn: Technical Library
 (For Dept. 462-4)
 Baltimore 4, Maryland

Antenna Systems, Inc.
 Manager Documentation
 Grenier Field
 Manchester, New Hampshire

Boeing Airplane Company
 Aero Space Division
 Attn: Technical Library
 M/P Antenna & Radomes Unit
 Seattle, Washington

Boeing Airplane Company
 Attn: Technical Library
 M/F Antenna Systems Staff Unit
 Wichita, Kansas

Chance Vought Aircraft, Inc.
 EHRU: Bu AER Representative
 Attn: Technical Library
 M/F Antenna Section
 P. O. Box 5907
 Dallas 22, Texas

Collins Radio Company
 Research Division
 Attn: Technical Library
 Cedar Rapids, Iowa

Convair
 Fort Worth Division
 Attn: Technical Library (Antenna
 Section)

Grants Lane
 Fort Worth, Texas

Convair
 Attn: Technical Library
 (Antenna Section)
 P. O. Box 1050
 San Diego 12, California

Dalmo Victor Company
 Attn: Technical Library
 (Antenna Section)
 1515 Industrial Way
 Belmont, California

Dorne & Margolin, Inc.
 Attn: Technical Library
 (Antenna Section)
 30 Sylvester Street
 Westbury, L. I., New York

Dynatronics, Inc.
 Attn: Technical Library
 (Antenna Section)
 Orlando, Florida

Electronic Communications, Inc.
 Research Division
 Attn: Technical Library
 1830 York Road
 Timonium, Maryland

Fairchild Engine & Airplane Corporation
 Fairchild Aircraft & Missiles Division
 Attn: Technical Library
 (Antenna Section)
 Hagerstown 10, Maryland

Georgia Institute of Technology
 Engineering Experiment Station
 Attn: Technical Library
 M/F Electronics Division
 Atlanta 13, Georgia

General Electric Company
 Electronics Laboratory
 Attn: Technical Library
 Electronics Park
 Syracuse, New York

General Electronic Labs., Inc.
 Attn: Technical Library
 (Antenna Section)
 18 Ames Street
 Cambridge 42, Massachusetts

DISTRIBUTION LIST (continued)
Contract AF33(657)-10474

General Precision Lab., Division of
General Precisions, Inc.
Attn: Technical Library
(Antenna Section)
63 Bedford Road
Pleasantville, New York

Goodyear Aircraft Corporation
Attn: Technical Library
M/F Dept. 474
1210 Massillon Road
Akron 15, Ohio

Granger Associates
Attn: Technical Library
(Antenna Section)
974 Commercial Street
Palo Alto, California

General Mills Electronics Division
Attn: Dr. H. P. Raabe
2003 East Hennepin Avenue
Minneapolis 13, Minnesota

Grumman Aircraft Engineering Corporation
Attn: Technical Library
M/F Avionics Engineering
Bethpage, New York

The Hallicrafters Company
Attn: Technical Library
(Antenna Section)
4401 W. Fifth Avenue
Chicago 24, Illinois

Hoffman Laboratories, Inc.
Attn: Technical Library
(Antenna Section)
Los Angeles 7, California

John Hopkins University
Applied Physics Laboratory
8621 Georgia Avenue
Silver Springs, Maryland

Hughes Aircraft Corporation
Attn: Technical Library
(Antenna Section)
Florence & Teal Street
Culver City, California

ITT Laboratories
Attn: Technical Library
(Antenna Section)
500 Washington Avenue
Nutley 10, New Jersey

U. S. Naval Ordnance Laboratory
Attn: Technical Library
Corona, California

Lincoln Laboratories
Massachusetts Institute of Technology
Attn: Document Room
P. O. Box 73
Lexington 73, Massachusetts

Litton Industries
Attn: Technical Library
(Antenna Section)
4900 Calvert Road
College Park, Maryland

John Hopkins University
Radiation Laboratory
Attn: Library
1315 St. Paul Street
Baltimore 2, Maryland

Lockheed Missile & Space Division
Attn: Technical Library (M/F Dept.
58-40, Plant 1, Bldg. 130)
Sunnyvale, California

The Martin Company
Attn: Technical Library
(Antenna Section) Mail No. T-38
P. O. Box 179
Denver 1, Colorado

The Martin Company
Attn: Technical Library (Antenna Section)
Baltimore 3, Maryland

Radiation, Inc.
Attn: Technical Library (M/F)
Antenna Section
Drawer 37
Melbourne, Florida

The Martin Company
Attn: Technical Library (M/F
Microwave Laboratory)
Box 5837
Orlando, Florida

McDonnell Aircraft Corporation
Attn: Technical Library
(Antenna Section)
Box 516
St. Louis 66, Missouri

Melpar, Inc.
Attn: Technical Library
(Antenna Section)
3000 Arlington Blvd.
Falls Church, Virginia

University of Michigan
Radiation Laboratory
Willow Run
201 Catherine Street
Ann Arbor, Michigan

Mitre Corporation
Attn: Technical Library (M/F Electronic
Warefare Dept. D-21)
Middlesex Turnpike
Bedford, Massachusetts

Northeastern University
Attn: Dodge Library
Boston 15, Massachusetts

North American Aviation, Inc.
Attn: Technical Library (M/F
Engineering Dept.)
4300 E. Fifth Avenue
Columbus 16, Ohio

North American Aviation, Inc.
Attn: Technical Library
(M/F Dept. 56)
International Airport
Los Angeles, California

Northrop Corporation
NORAIR Division
1001 East Broadway
Attn: Technical Information (3924-3)
Hawthorne, California

Maxson Electronics Corporation
Great River, L. I., New York

Ohio State University Research Foundation
Attn: Technical Library (M/F Antenna
Laboratory)
1314 Kinnear Road
Columbus 12, Ohio

Ohio State University Research Foundation
Attn: Dr. C. H. Walter
1314 Kinnear Road
Columbus 12, Ohio

Philco Corporation
Government & Industrial Division
Attn: Technical Library (M/F Antenna
Section)
4700 Wissachickon Avenue
Philadelphia 44, Pennsylvania

Westinghouse Electric Corporation
Air Arms Division
Attn: Librarian (Antenna Lab)
P. O. Box 746
Baltimore 3, Maryland

Wheeler Laboratories
Attn: Librarian (Antenna Lab)
Box 561
Smithtown, New York

Electrical Engineering Research Laboratory
University of Texas
Box 8026, University Station
Austin, Texas

University of Michigan Research Institute
Electronic Defense Group
Attn: Dr. J. A. M. Lyons
Ann Arbor, Michigan

Radio Corporation of America
RCA Laboratories Division
Attn: Technical Library
(M/F Antenna Section)
Princeton, New Jersey

Rome Air Development Center
Attn: RAALD
Griffiss Air Force Base, New York

Aeronautical Systems Division
Attn: ASRNC-2
Wright-Patterson Air Force Base, Ohio

DISTRIBUTION LIST (continued)
 Contract AF33(657)-10474

Fano-Wooldrige Corporation
 Attn: Librarian (Antenna Lab)
 Caroga Park, California

Rand Corporation
 Attn: Librarian (Antenna Lab)
 1700 Main Street
 Santa Monica, California

Rantec Corporation
 Attn: Librarian (Antenna Lab)
 23999 Ventura Blvd.
 Calabasas, California

Raytheon Corporation
 Equipment Division
 Library - J. Portsch
 P. O. Box 520
 Waltham 54, Massachusetts

Republic Aviation Corporation
 Applied Research & Development Division
 Attn: Librarian (Antenna Lab)
 Farmingdale, New York

Sanders Associates
 Attn: Librarian (Antenna Lab)
 95 Canal Street
 Nashua, New Hampshire

Southwest Research Institute
 Attn: Librarian (Antenna Lab)
 8500 Culebra Road
 San Antonio, Texas

H. F. B. Singer Corporation
 Attn: Librarian (Antenna Lab)
 State College, Pennsylvania

Sperry Microwave Electronics Company
 Attn: Librarian (Antenna Lab)
 P. O. Box 1828
 Clearwater, Florida

Sperry Gyroscope Company
 Attn: Librarian (Antenna Lab)
 Great Neck, L. I., New York

Stanford Electronic Laboratory
 Attn: Librarian (Antenna Lab)
 Stanford, California

Stanford Research Institute
 Attn: Librarian (Antenna Lab)
 Menlo Park, California

Sylvania Electronic System
 Attn: Librarian (M/F Antenna &
 Microwave Lab)
 100 First Street
 Waltham 54, Massachusetts

Sylvania Electronic System
 Attn: Librarian (Antenna Lab)
 P. O. Box 188
 Mountain View, California

Technical Research Group
 Attn: Librarian (Antenna Section)
 2 Aerial Way
 Syosset, New York

Ling Temco Aircraft Corporation
 Temco Aircraft Division
 Attn: Librarian (Antenna Lab)
 Garland, Texas

Texas Instruments, Inc.
 Attn: Librarian (Antenna Lab)
 6000 Lemmon Avenue
 Dallas 9, Texas

A. S. Thomas, Inc.
 Attn: Librarian (Antenna Lab)
 355 Providence Highway
 Westwood, Massachusetts

New Mexico State University
 Head Antenna Department
 Physical Science Laboratory
 University Park, New Mexico

Research Librarian
 Case Institute of Technology
 University Circle
 Cleveland 6, Ohio

DISTRIBUTION LIST (continued)
Contract AF33/657) - 10474

Bell Telephone Laboratories, Inc.
Whippany, New Jersey
Attn: Technical Reports Librarian
Room 2A-165

Robert G. Hansen
Aerospace Corporation
Box 95085
Los Angeles 45, California

Dr. Richard C. Becker
10829 Berkshire
Westchester, Illinois

Dr. W. M. Hall
Raytheon Company
Surface Radar and Navigation Operations
Boston Post Road
Wayland, Massachusetts

Dr. Robert L. Carrel
Collins Radio Corporation
Antenna Section
Dallas, Texas

Dr. A. K. Chatterjee
Vice Principal and Head of the De-
partment of Research
Birla Institute of Technology
P. O. Mesra
District-Ranchi (Bihar) India

University of Dayton
Research Institute
Attn: Professor Douglas Hanneman
300 College Park
Dayton, Ohio

Technische Hochschule
Attn: H. H. Meinke
Munich, Germany

NASA Goddard Space Flight Center
Attn: Antenna Branch - Mr. Lantz
Greenbelt, Maryland

W. P. Patton
152 Ramblewood Road
Moorestown, New Jersey

Aeronautic Division
Ford Motor Company
Ford Motor - Attn: Mr. J. M. Black
Newport Beach, California

Professor A. A. Oliver
Polytechnic Institute of Brooklyn
Microwave Research Institute
55 Johnson Street
Brooklyn 1, New York

U. S. Naval Ordnance Laboratory
Attn: Technical Library
Corona, California

Avco Corporation
Research and Advanced Development
Division
Attn: Research Library/T.A. Rupprecht
201 Lowell Street
Wilmington, Massachusetts

Raytheon Company
Missile and Space Division
Attn: Research Library
Bedford, Massachusetts

Teledyne Systems, Incorporated
Attn: Technical Library /Antenna Section
1625 E. 126th Street
Hawthorne, California

National Research Council
Attn: Microwave Section
Ottawa 2, Canada

Sichak Associates
Attn: W. Sichak
518 Franklin Avenue
Nutley, New Jersey

Radio Corporation of America
Missile and Service Radar Division
Attn: Manager, Antenna Engineering
Skill Center
Moorestown, New Jersey

Advanced Development Laboratories, Inc.
Haines Street
Nashua, New Hampshire

DISTRIBUTION LIST (Continued)
 Contract AF33(657)-10474

Cornell Aeronautical Lab.
 Attn: Research Library
 Buffalo, New York

Fairchild Stratos Corporation
 Aircraft-Missiles Division
 Attn: Technical Library (Antenna Section)
 Hagerstown 10, Maryland

General Electric Company
 Light Military Electronics Department
 French Road
 Utica, New York

General Electric Company
 General Engineering Laboratory
 Bldg. 371, Room 478
 Schenectady, New York

Goodyear Aircraft Corporation
 Antenna Department
 Litchfield Park
 Phoenix, Arizona

Laboratory for Electronics, Inc.
 Antenna Department
 1079 Commonwealth Avenue
 Boston 15, Massachusetts

Lockheed Aircraft
 Electronic and Armaments System Office
 Burbank, California

Motorola, Inc.
 Western Military Electronics Division
 P. O. Box 1417
 Scottsdale, Arizona

Philco Corporation
 Antenna Section
 3875 Fabian Way
 Palo Alto, California

Space Technology Laboratory
 Attn: Research Library
 P. O. Box 95100
 Los Angeles 45, California

All Products Company
 Attn: James Buzbee
 Mineral Wells, Texas

Avco Corporation
 Electronic and Ordnance Division
 Attn: Technical Library
 Cincinnati 41, Ohio

Bendix Corporation
 Research Labs Division
 Attn: G. M. Peace
 Southfield (Detroit), Michigan

Douglas Aircraft Co., Inc.
 Attn: MSSD Technical Library
 (Antenna Section)
 3000 Ocean Park Blvd.
 Santa Monica, California

Emerson and Cuming, Inc.
 Attn: E. J. Luoma
 869 Washington Street
 Canton, Massachusetts

Radioplane Company
 Attn: Librarian (M/F Aerospace Lab)
 1515 Rancho Conejo Blvd.
 Newbury Park, California

Hughes Aircraft Company
 Attn: Antenna Section
 Fullerton, California

Vincent De Santi, Chief
 Exchange Section
 Document Control Department
 Scientific and Technical Information
 Facility
 P. O. Box 5700
 Bethesda, Maryland

Canoga Electronics Corporation
 Attn: Advanced Programs Department
 15330 Oxnard Street
 Van Nuys, California

North American Aviation, Inc.
 Autonetics Division
 Advanced Engineering Laboratory
 Attn: System Technology Department
 La Palmas Road
 Anaheim, California