

UNCLASSIFIED

AD 4 2 5 7 1 1

DEFENSE DOCUMENTATION CENTER

FOR

SCIENTIFIC AND TECHNICAL INFORMATION

CAMERON STATION, ALEXANDRIA, VIRGINIA



UNCLASSIFIED

NOTICE: When government or other drawings, specifications or other data are used for any purpose other than in connection with a definitely related government procurement operation, the U. S. Government thereby incurs no responsibility, nor any obligation whatsoever; and the fact that the Government may have formulated, furnished, or in any way supplied the said drawings, specifications, or other data is not to be regarded by implication or otherwise as in any manner licensing the holder or any other person or corporation, or conveying any rights or permission to manufacture, use or sell any patented invention that may in any way be related thereto.

DISCLAIMER NOTICE

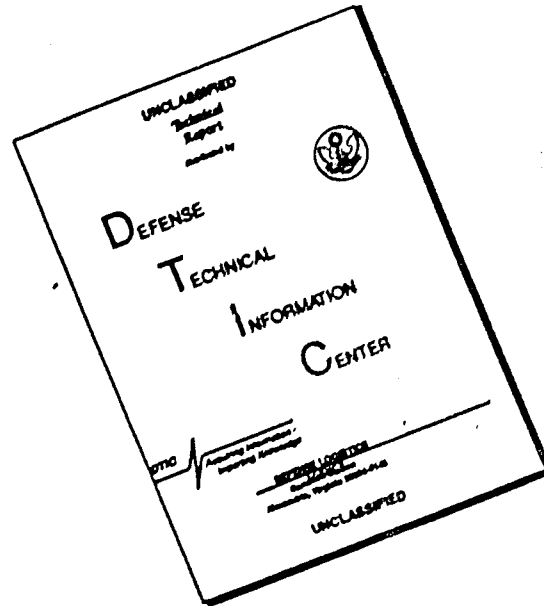

THIS DOCUMENT IS BEST QUALITY AVAILABLE. THE COPY FURNISHED TO DTIC CONTAINED A SIGNIFICANT NUMBER OF PAGES WHICH DO NOT REPRODUCE LEGIBLY.

COMPARATIVE PHYSIOLOGY
OF TEMPERATURE REGULATION

Editors
JOHN P. HANNON
ELEANOR VIERECK

ARCTIC AEROMEDICAL LABORATORY
FORT WAINWRIGHT
ALASKA
1962

COMPARATIVE PHYSIOLOGY
OF TEMPERATURE REGULATION

PART 1

Editors

JOHN P. HANNON
ELEANOR VIERECK

ARCTIC AEROMEDICAL LABORATORY
FORT WAINWRIGHT
ALASKA
1962

ACKNOWLEDGEMENTS

Grateful acknowledgement is made to the following for permission to publish copyrighted figures: American Physiological Society, George Banta Publishing Co., St. Martin's Press, the Missouri Agricultural Experiment Station, and Reinhold Publisher's.

PROCEEDINGS

SYMPOSIA ON ARCTIC BIOLOGY AND MEDICINE

II. COMPARATIVE PHYSIOLOGY OF TEMPERATURE

REGULATION

Symposium held July 17, 18, 19, 1961 at the
Arctic Aeromedical Laboratory
Fort Wainwright, Alaska

Edited by
John P. Hannon, Head, Department of Physiology
Arctic Aeromedical Laboratory
Eleanor G. Viereck, Research Physiologist
Arctic Aeromedical Laboratory

Symposium held under the auspices of
Geophysical Institute
University of Alaska
College, Alaska

1962

TABLE OF CONTENTS

Part I. The Evolution of Homeothermy.

1. Introductory Remarks,
John P. Hannon vii
2. Some Temperature Adaptations of Poikilothermic
Vertebrates, C. Ladd Prosser 1
3. The Evolution of Avian Temperature Regulation
William R. Dawson 45
4. The Evolution of Mammalian Temperature Regulation,
Kjell Johansen 73

Part II. The Maintenance of Homeothermy.

5. Heterothermy in the Cold Adaptations of Warm
Blooded Animals, Laurence Irving. 133
6. Maximal Metabolism and Organ Thermogenesis in
Mammals, Ladislav Jansky 175
7. The Physiology of Mammalian Cold Acclimation,
J. Sanford Hart 203
8. Temperature Responses and Adaptations in Domestic
Mammals, Max Kleiber. 243
9. Temperature Responses and Adaptations in Birds,
George C. West 291
10. Racial Variations in Human Responses to
Temperature, Frederick A. Milan 325
11. Temperature Regulation in Animals Native to
Tropical and High Altitude Environments, Peter R.
Morrison 381
12. Temperature Regulation in Animals Native to the
Desert Environment, Jack W. Hudson 413

BIOGRAPHICAL NOTES ON AUTHORS

C. Ladd Prosser obtained his B.A. at the University of Rochester in 1929, his Ph.D. at the Johns Hopkins University Zoology Department in 1932, and now holds the title of Professor of Physiology, University of Illinois. He has performed outstanding work in the fields of physiology of nervous systems of invertebrates, comparative pharmacology of hearts, conduction in non-striated muscles, and physiological adaptation: (1) mechanisms and (2) role in evolution. The text, *Comparative Animal Physiology*, edited by Prosser, et al., needs no introduction.

William R. Dawson received his Ph.D. from Stanford, Department of Zoology, in 1953, and is now assistant professor in the Department of Zoology at the University of Michigan. He has worked on temperature regulation and water balance of birds and reptiles, reptile metabolism, and avian paleontology.

Kjell Johansen has the degree Cand. Real. from Oslo, Norway. He has worked with many kinds of vertebrates and higher invertebrates. He is concerned with physiological phylogeny, and comparative cardiovascular physiology. He is now at the University of Oslo, Institute for Experimental Medical Research.

Laurence Irving received the degree of A.B. at Bowdoin in 1916, the A.M. from Harvard in 1917, and the Ph.D. from Stanford in 1925. He has been awarded honorary degrees also: an honorary M.D. from Oslo in 1956 and an honorary D.Sc. from Bowdoin in 1959. His long and productive list of research accomplishments include work in diverse fields such as adaptations to cold in mammals and birds, migrations of Alaskan birds, and respiratory exchange in diving mammals. He has elucidated the principle of peripheral heterothermy.

Ladislav Jansky received the P.H. degree in 1958 from Charles University, Prague, Department of Animal Physiology. He now holds the title of Assistant Professor, Department of Comparative Physiology, Charles University. His research interests are: metabolism in the cold, cold adaptation, maximal metabolism, organ thermogenesis, and hibernation.

J. Sanford Hart received the B.A. 1939, the M.A. 1943, the Ph.D. 1949 all from Toronto, and was elected a F.R.S.C. in 1956. His present title is Head, Environmental Physiology section, Division of Applied Biology, NRC, Ottawa, Canada. His general interest encompasses the environmental physiology of homeotherms, acclimatization in mammals and birds native to cold climates metabolic mechanisms of acclimation to cold in rats, shivering mechanisms and organ thermogenesis, and cardiovascular responses to exercise and cold exposure.

Max Kleiber obtained the D.Sci. in 1924 and the Privat Dozent in 1928 from the Federal Institute of Technology, Zurich, Switzerland. He is now Professor Emeritus at the University of California and has been awarded an honorary LL.D. from California in 1961. His numerous contributions to physiology have been in the fields of energy metabolism and feed utilization, environmental temperature, energy metabolism and food utilization (in chicks and cows), measurement of replacement equivalents for food in animal production, energy metabolism and nutritive deficiencies, intermediary metabolism especially in milk formation using radiocarbon (C^{14}) as a metabolic tracer, and phosphorus and calcium metabolism using P^{32} and Ca^{45} as tracers. His recent book, Fire of Life, is destined to become a classic.

George C. West received his B.A. degree from Middlebury College in 1953, and his M.S. and Ph.D. in Zoology under Dr. S. C. Kendeigh at the University of Illinois in 1956 and 1958 respectively. He spent a year doing post-doctoral research at Illinois and a year as a post-doctoral fellow of the National Research Council of Canada with Dr. J. S. Hart. He is now Assistant Professor of

Zoology at the University of Rhode Island and on the summer staff of the Canadian National Research Council. His major research interests and publications are in the fields of ecology and physiology of avian energetics and migration.

Frederick A. Milan obtained his B.A. in 1952 from the University of Alaska and his M.A. from the University of Wisconsin, 1959. He is currently studying for the Ph.D. degree at the University of Wisconsin, Department of Anthropology. His investigations of human response to cold have taken him to the Australian interior, the arctic coast of Alaska, the Tierra del Fuego, Lapland, the Antarctic, the Canadian Archipelago, and mountain summits in Alaska.

Peter Reed Morrison has a B.S. from Swarthmore College in 1940 and a Ph.D. from Harvard University Biology Department in 1947. Presently he is Professor of Physiology and Zoology, University of Wisconsin. His work includes the fields of temperature regulation and energy metabolism in wild mammals, altitudinal adaptations in wild mammals, coagulation and the polymerization of fibrinogen, hibernation, physiological descriptions of intact animals, and individual tissue specializations.

Jack W. Hudson obtained his M.A. from Occidental College, Biology Department, 1950 and his Ph.D. from University of California, Los Angeles, Zoology Department, 1960. He is now a lecturer in that department. The list of his research interests is: Aestivation and hibernation in mammals, water metabolism and kidney function in desert mammals, uric acid excretion in birds, relation of heart rate, body size and thermal neutrality in birds.

LIST OF DISCUSSANTS

Adams, Thomas
Department of Physiology
University of Washington

Hannon, John P.
Physiology Department
Arctic Aeromedical Laboratory
Fort Wainwright, Alaska

Durrer, John P.
Physiology Department
Arctic Aeromedical Laboratory
Fort Wainwright, Alaska

Kessel, Brina
Department of Biology
University of Alaska
College, Alaska

Eagan, Charles J.
Physiology Department
Arctic Aeromedical Laboratory
Fort Wainwright, Alaska

Miller, Keith
Arctic Public Health Research
Laboratory
P. O. Box 960
Anchorage, Alaska

Evonuk, Eugene
Physiology Department
Arctic Aeromedical Laboratory
Fort Wainwright, Alaska

Opsahl, James F.
Department of Zoology
Winona State College
Winona, Minnesota

Folk, G. Edgar, Jr.
Department of Physiology
University of Iowa
Iowa City, Iowa

Pitelka, Frank
Museum of Vertebrate Zoology
Berkeley 4, California

INTRODUCTORY REMARKS

John P. Hannon

On behalf of the Commander and Staff of the Arctic Aeromedical Laboratory, it is indeed a pleasure to welcome such distinguished guests to this second Symposium on Arctic Biology and Medicine. We hope that your trip was an enjoyable one, despite the long distances many of you were forced to travel. It is our desire that you remember this visit to our Laboratory and to the State of Alaska as a pleasant one as well as a scientifically profitable experience, and if there is anything that I or the other Staff members might do to assure this end, please do not hesitate to call on us. Before we begin the formal portions of our program, I would like to say a few words regarding our reasons for selecting the Comparative Physiology of Vertebrate Temperature Regulation as a symposium topic.

As you are all well aware, the ability to adapt to an adverse or unusual environment is one of the more fundamental characteristics of all living things. In fact, we might go so far as to say that the ability to adapt to such environments is an essential prerequisite to the successful perpetuation of any population of plants or animals. Thus, when a species is unable to adapt to an adverse environment it becomes extinct.

To those of us who live in arctic or subarctic areas, the adaptations of plants and animals to adverse environmental temperatures are of singular importance. The accumulation of knowledge about such adaptations therefore, is one of the primary reasons for inviting you to participate in this Symposium.

Since temperature adaptation is a very broad subject, it was obviously impractical to attempt to organize a symposium that would adequately cover the whole field. Consequently, we decided to continue the pattern that was followed in our first Symposium on Arctic Biology and Medicine; namely, to give intensive consideration to one rather narrow aspect of this field. Furthermore, we also decided

that we should give primary emphasis to subject material that had not been discussed in detail at previous symposia.

The Comparative Physiology of Vertebrate Temperature Regulation seemed to admirably meet these criteria. Here was a subject where the work covered practically the whole range of zoological sciences. Here, also, was a subject where the quite similar work by investigators in one scientific discipline often went unrecognized by investigators in another closely related scientific discipline. For example, those of us who study the biochemistry of cold acclimatization in small laboratory mammals may be unfamiliar with biochemical studies on fish or other vertebrate heterotherms; those of us who study the temperature regulation of cats and dogs may not be cognizant of temperature regulation studies on domestic animals such as the cow; and those of us who are concerned with the natural temperature adaptations of arctic animals may not relate our information to studies that have been conducted on desert animals.

Our first concern, therefore, in organizing this symposium was to bring together representatives of the various scientific disciplines who are interested in vertebrate temperature regulation. Beyond this, we had two other desires in organizing this symposium. One of these was to obtain participants who could discuss vertebrate temperature regulation from the evolutionary standpoint. Our other desire was to obtain participants who could interrelate temperature adaptations to other forms of environmental adaptation. I feel that we have been at least partially successful in achieving both of these desires. And in this regard I would like to express my gratitude to Dr. Laurence Irving, Dr. J. Sanford Hart and Dr. C. Ladd Prosser for their valuable suggestions regarding possible participants and subject material.

ACCLIMATION OF POIKILOTHERMIC VERTEBRATES TO LOW TEMPERATURES

C. L. Prosser

Temperature limits the distribution of many poikilothermic animals, and knowledge of responses to temperature is important for physiological ecology. Natural selection acts on the capacity for change within a given genotype; hence it is important to learn how such an environmental variable as temperature brings about biochemical changes in individual animals. Natural variation in respect to temperature relations can best be described in terms of the responses to the stresses of cold and heat: survival, reproduction, various rate functions, behavior. Once this variation is described for natural populations of animals, it is necessary to analyze that component which is genetic and that which is environmentally induced; this analysis is permitted by acclimation of similar animals to a range of temperatures. Finally, the physiological mechanisms of the variation with respect to temperature can be pursued down to the molecular changes, and the sequence of events by which temperature brings about change in genetically similar individuals can be elucidated.

COMPARISON OF HOMEOTHERMS AND POIKILOTHERMS

The differences between a poikilotherm (temperature conformer) and a homeotherm (temperature regulator) are multiple and fundamental. Birds and mammals evolved from reptiles and differ from present-day reptiles in possession of a thermoregulating center in the brain, in insulation, in peripheral vascular responses to ambient temperature (which are opposite to those of reptiles), and in type of metabolic compensation. Varying degrees of homeothermy---expressed in hibernation, estivation, nocturnal temperature drop, and heterothermy of tissues---indicate that some animals can shift from homeothermy to poikilothermy and that certain peripheral tissues of

some birds and mammals can function over a much wider range of temperature than can the core tissues. The corresponding enzymes must differ in cold functional skin and in constantly warm liver.

When the ambient temperature (air or water) falls, a homeotherm shows a typical sequence of protective responses. The metabolic response in relation to body temperature is diagrammed in Figure 1. Peripheral cold receptors signal the drop in skin temperature and initiate reflexes such as hair or feather erection, peripheral vasoconstriction, and behavior such as huddling. These initial responses result in heat retention by increased insulation. With further chilling, the temperature-sensitive center in the hypothalamus is stimulated and further defenses may be mobilized. Cooling below the critical ambient temperature or to that temperature below which insulative changes are inadequate so that a transient drop in body temperature occurs, results in increased metabolism which serves to maintain body temperature. Nor-adrenaline secretion is enhanced, and shivering may be initiated and heat production increased. If cold stress continues, the hypothalamus activates the anterior pituitary to liberate adrenocorticotrophic and thyrotropic hormones. The adrenal cortex and thyroid initiate a metabolic increase and extensive biochemical responses of various organs, particularly liver to varying extents in different species. In laboratory acclimation to cold some animals show an increased standard metabolism; in field acclimatization many animals show a reduction in critical temperature. Some metabolic enzymes become more active than others and the sensitivity to stimulating hormones is altered (Hannon, 1960; Hart, 1958; Heron, 1960). The increased metabolism of cold acclimation may persist after withdrawal of hormonal stimulation, and in the annual cycle of winter, insulative adaptations make metabolic ones less necessary. In some species the adrenal cortex is active and the thyroid less active under natural winter conditions.

Over a certain range the insulative changes are sufficient to maintain relative constancy of body temperature in a homeotherm. At elevated ambient temperatures, reflexes provide increased peripheral blood flow, surface cooling by sweat, panting, and other means of controlling body temperature. However, there is no reduction in metabolism and in conditions of fever the oxygen consumption may increase.

POIKILOTHERMIC ADAPTATIONS

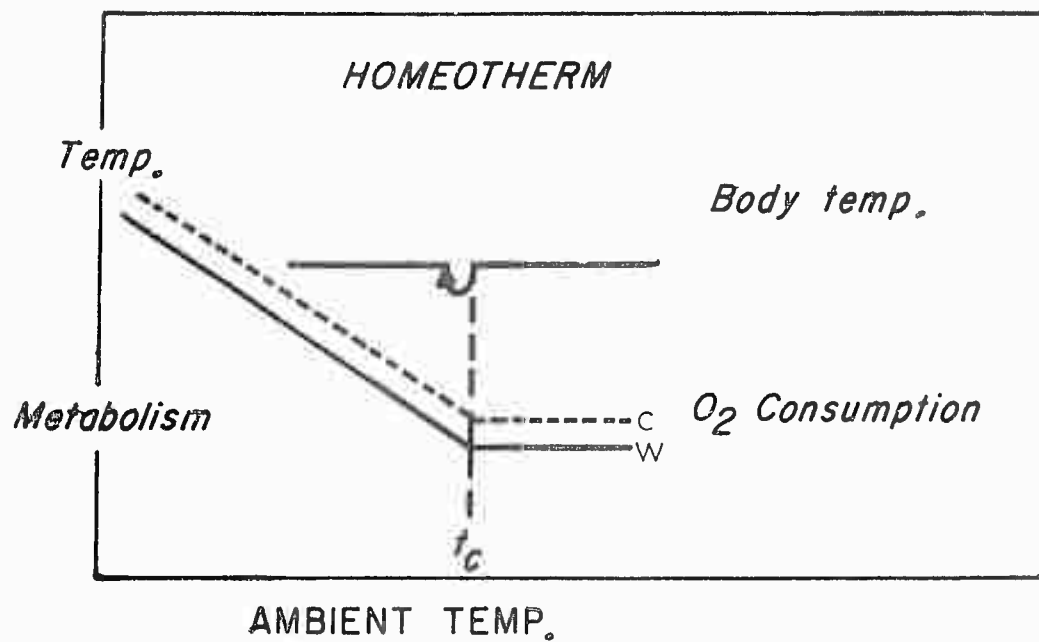

Figure 1. Schematic representation of temperature regulation in a homeotherm. At a critical ambient temperature the body temperature is temporarily reduced, but metabolism increases, thus maintaining body temperature. C, cold acclimated; W, warm acclimated.

PROSSER

When environmental temperature drops, the temperature of a poikilotherm (e. g., fish) drops with it. Any metabolizing organism produces some heat, and the liver of a large fish may be significantly warmer than its environment. But poikilotherms lack insulation, and their body temperatures are virtually the same as that of their environments. If the drop in temperature is rapid and considerable, the poikilotherm may enter a chill coma and even die from respiratory failure. If the cold stress is less, there may be initial stimulation, increased nervous activity (well shown in crustaceans and insects) and an initial transient increase in oxygen consumption, the so-called initial shock reaction. This is followed by a decline of metabolism to a stabilized state which corresponds to the reduced temperature. The Q_{10} for metabolism is usually between 2.0 and 2.5; hence the metabolic response to temperature is steeper than the change in body temperature. With time (days or weeks) some metabolic compensation may occur. The compensatory changes for either a fall or a rise in temperature in a poikilotherm are diagrammed in Figure 2. The time course of acclimation differs according to the function measured and the kind of animal.

Precht (Precht, 1958; Precht et al., 1955) has classified the patterns of acclimation as indicated in Figure 3 and has termed them capacity adaptations. The five possible patterns are: (1) overcompensation so that metabolism is higher in the cold than at the initial temperature, (2) perfect compensation with the same metabolism at each temperature, (3) partial compensation, (4) no compensation, the metabolism continuing to follow the van't Hoff relation, and (5) inverse compensation or further reduction in metabolism. The commonest pattern of acclimation is the third, partial compensation, so that if the metabolism of animals from temperatures t_1 and t_2 is measured at the same intermediate temperature, the one acclimated to the cold has a higher metabolism. This acclimation pattern can apply to other rate functions besides metabolism—heart rate, breathing rate etc. A comparable sequence is described for moderate increases in temperature (Precht, 1958). Acclimation to heat is a reduction in metabolism below the initial level determined by the Q_{10} relation (Gelineo, 1959). The net effect of long-term acclimation is to tend toward relative constancy of energy liberation despite changes in body temperature.

POIKILOTHERMIC ADAPTATIONS

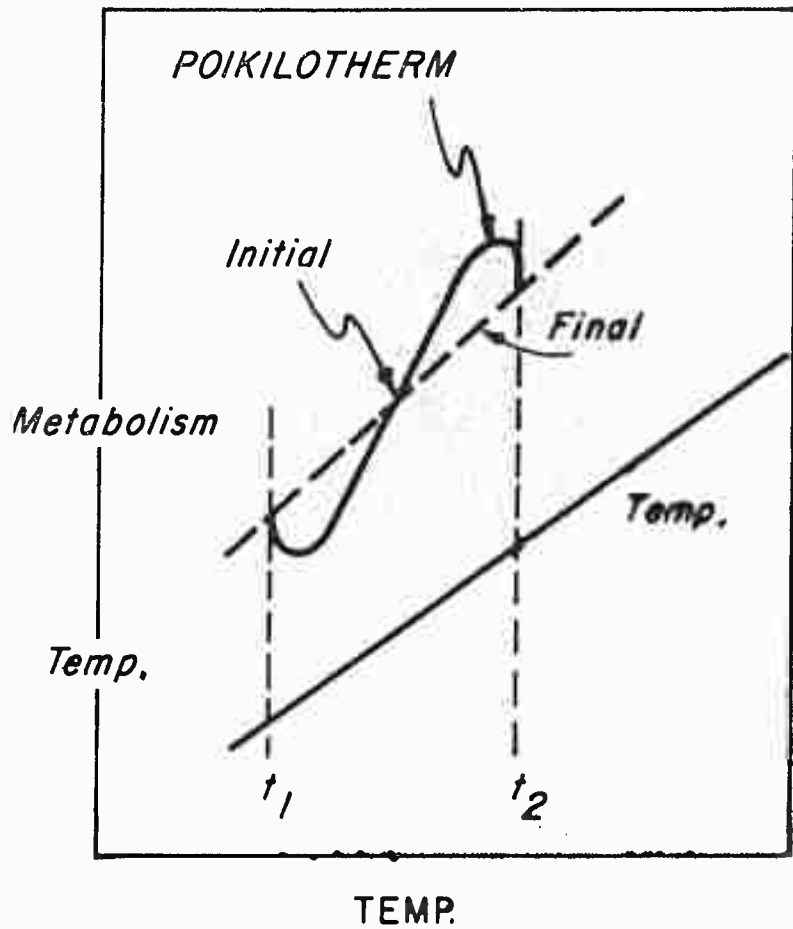

Figure 2. Schematic representation of temperature relations in a poikilotherm. Metabolism decreases more steeply than body temperature. Acclimation results in a rise in metabolism at low temperature and a fall at high temperature, thus tending toward relative constancy of metabolism as the environmental temperature changes.

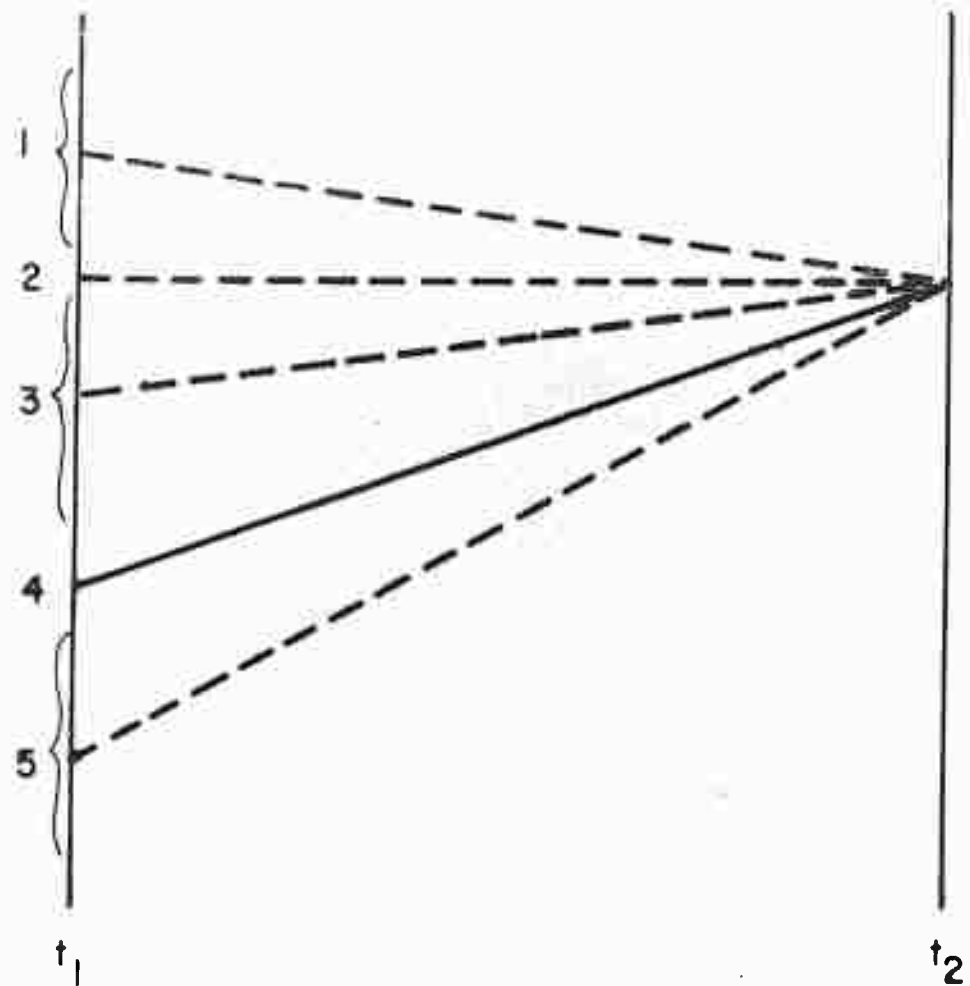

Figure 3. Precht's patterns of metabolic acclimation in cold. Animal moved from a high temperature (t_2) to a low one (t_1) and metabolic rate falls directly along solid line. Rate remains at 4 if no acclimation occurs with time (van't Hoff approximation); rate rises to 2 if acclimation is complete. Pattern 1 represents over-compensation, 3, partial compensation, and 5, under-compensation or reverse acclimation. Modified from Precht, 1958.

POIKILOTHERMIC ADAPTATIONS

Tolerance of sudden temperature stress, called "resistance acclimation" by Precht, is also modified. This is shown by shifts of both high lethal and low lethal temperatures according to acclimation (Fry et al., 1946; Fry, 1947). The curves describing rise or fall of the two lethal temperatures as a function of acclimation need not be parallel, and the area enclosed by both curves, the tolerance zone, is species specific. The relation of temperature tolerance or resistance acclimation to capacity acclimation is not known, and further knowledge of heat and cold death might indicate which processes are altered. Stress tests provide a useful tool for analysis of acclimation.

Poikilothermic vertebrates differ from homeotherms in that they tend by compensation to maintain relatively similar activity when body temperature changes, whereas the homeotherm maintains constant temperature. There is no "comfort" or thermoneutral zone for the poikilotherm as long as chill or heat coma are avoided. Efficiency of feeding and general body activity increase in a non-linear fashion up to some "optimal" temperature which may be only a few degrees below the lethal point. Furthermore, there is no evidence in poikilotherms for a sequence comparable to Selye's stress syndrome of mammals.

Whether or not hormones are involved in the enzymatic changes of metabolic acclimation in poikilotherms is not known. Evidence concerning thyroid participation in adaptation of fish is conflicting (Hoar, 1959). A slight increase in height of thyroid epithelium at elevated but not at reduced temperatures was reported for the minnow (*Phoxinus*) (Barrington and Matty, 1954), and in trout the thyroid shows signs of increased activity in the cold (Olivereau, 1955b). However, no histological change was found in thyroids of catfish, carp, tench, eel, *Mugil*, or *Scyllium* after acclimation in cold (7°C - 14°C) or warm (20°C - 23.5°C) (Olivereau, 1955a,b,c). Thiourea treatment is said to eliminate metabolic differences between cold- and warm-acclimated crucian carp (*Carassius*) (Suhrman, 1955), but thiourea increases the differences in *Leuciscus* (Auerbach, 1957). Resistance to cold in long-day goldfish increases when thyroid hormone is injected (Hoar, 1959). Thiourea increases cold resistance of goldfish and decreases that of the crucian carp (*Carassius*) (Precht, 1958). Iodine uptake by the thyroid is slightly increased by

cold in a minnow (Umbra) but not in Fundulus (Berg et al., 1959). Temperature effect on the thyroid of amphibians is negligible. However, seasonal variations in thyroid activity of both fish and amphibians, probably associated with photoperiod, are considerable. The adrenals of poikilothermic vertebrates produce corticosteroids which seem to function primarily in potassium and sodium balance; no role in carbohydrate metabolism has been found in poikilotherms (Jones et al., 1959). The amount of hydroxycorticosteroid in the blood of a fish may be increased after swimming, but no response to temperature stress has been reported (Jones et al., 1959). Changes in metabolic enzymes in compensation for temperature occur in yeast (Precht, 1956) and in invertebrates where thyroxin and iodinated tyrosines and corticosterone do not function as they do in homeotherms. Also, the biochemical changes of poikilotherms in temperature adaptation can be either an increase or a decrease in specific enzymes. It seems likely that the acclimation of poikilotherms is either a direct effect of temperature on enzyme forming systems or an indirect enzyme induction due to differential utilization of substrates at different temperatures. Thus there is little similarity in the metabolic acclimation of poikilotherms and homeotherms.

DIFFICULTIES AND METHODS IN ACCLIMATION MEASUREMENT

The analysis of biochemical mechanisms of temperature acclimation is beset with many difficulties. The identification of limiting steps involves extrapolation to the intact animal from measurements on tissue slices, homogenates, isolated mitochondria, and purified enzymes. Such extrapolation is difficult and based on several assumptions. It is not possible to provide in vitro conditions which duplicate in all respects those under which an enzyme functions in vivo. Balance of organic as well as inorganic ions, concentrations of co-factors and hormones cannot be duplicated, nor can spatial organization, as of particulates in a cell. An important part of acclimation involves regulation by the neuroendocrine system. Yet the integrated system can be analyzed only by taking it apart. One method of

POIKILOTHERMIC ADAPTATIONS

identifying changes in enzyme activity is to observe effects of inhibitors; yet these are not nearly so specific as desired. Another method is to purify enzymes, but extraction procedures are often uncertain as to recovery or loss of activity. A common method is to supply an excess of a specific substrate so that the enzyme acting on it is made limiting; this provides a useful comparison between systems treated differently (as by temperature), but it does not tell much about limiting steps in vivo. Tracing labelled substrates is informative and has not often been used in acclimation biochemistry, although it has indicated a general similarity of metabolic paths in fish and mammals (Brown, 1960; Brown and Tappel, 1959; Martin and Tarr, 1961). Useful information can be obtained from kinetic studies of both intact and dissected systems.

A serious problem, especially with poikilotherms, is the identification of appropriate environmental variables. Three factors, temperature, nutrition, and photoperiod, interact in an inextricable way. Many fish and amphibia eat little in the cold, and it has been common practice to observe acclimation in starved animals. Unfortunately a fish starved at 25° C is not comparable in its food reserves to one starved at 5° C. Also if each is fed ad libitum, the absorption of food may be so slow in the cold that the nutritional state is different from that of one fed at 25° C. We have evidence that the metabolic differences are greater in starved than in fed goldfish kept at low and high temperatures. Various methods, such as feeding followed by cross acclimation so that the total time spent at the two temperatures is the same for both groups, have been used in an effort to approach nutritional equivalence, but no method is fully satisfactory.

Photoperiod has marked metabolic effect in fish and amphibians. Ekberg (1961) found a greater difference between enzymes from cold and warm acclimated fish on a 17-hour than on a 7-hour photoperiod; he also found a marked seasonal difference in the metabolic response of goldfish gills. Roberts (1961) observed a photoperiod effect on Carassius carassius at 20° C but not at lower temperatures. Hoar (1955; Hoar and Robertson, 1959) observed seasonal differences in temperature tolerance and in oxygen consumption by goldfish even when acclimated at the same temperature; these seasonal effects reflect photoperiod and may be associated with enhanced thyroid activity on short photoperiod. Frogs show marked seasonal differences in many of their physiological proper-

ties independent of temperature. It is important, therefore, that photoperiod be kept the same for different conditions of temperature acclimation.

Another difficulty in metabolic acclimation results from the differences between active and rest (standard) metabolism and the impossibility of controlling movement in poikilotherms. There is evidence that active and rest metabolism follow slightly different enzyme pathways. Data from anesthetized fish differ from those from quiescent awake ones; hence anesthetics are usually avoided.

Kinetic analyses have been useful in studies of enzyme induction and of the role of amino acid pools in protein synthesis, but such analyses have not often been applied to problems of acclimation.

The time-course of acclimation deserves more attention. One related method is to compare the rate-temperature curves of stabilized rate functions for poikilothermic animals that have been differently acclimated (Prosser, 1958). Such curves permit some speculation concerning the mechanism of acclimation (Figure 4). When there is no acclimation, the rate-temperature curves coincide for animals from either temperature (Figure 4a). This lack of acclimation has been described for winter and summer Cunner (Haugaard and Irving, 1943) and for a variety of insects and shore invertebrates. One type of acclimation to cold is a translation of the rate curve to the left or upward (Figure 4b) without change in slope. Such simple translation has been observed for O_2 consumption by the scorpene trout (Gelinco, 1959), cocarboxylase of the eel (Carlsen, 1953), oxygen consumption by salamanders, *Eurycea* (Vernberg, 1952) and *Triturus* (Riech et al., 1960), for metabolism of some northern and southern species of frogs (Tashian, 1957), of the lizard *Sceloporus* at 16° C and 23° C (Dawson and Bartholomew, 1956) as well as for numerous invertebrates (Prosser, 1961).

A third pattern (Figure 4c) is rotation about a midpoint, i. e., change in slope or Q_{10} only. This occurs for O_2 consumption by the European eel with an intersection of curves for 11° C and 26° C acclimation at about 21° C (Precht, 1951) and also for metabolism by the salamander *Plethodon* (Vernberg, 1952). The most common pattern is a combination of translation with rotation. When the Q_{10} of cold-acclimated animals is less than that of warm-acclimated

POIKILOTHERMIC ADAPTATIONS

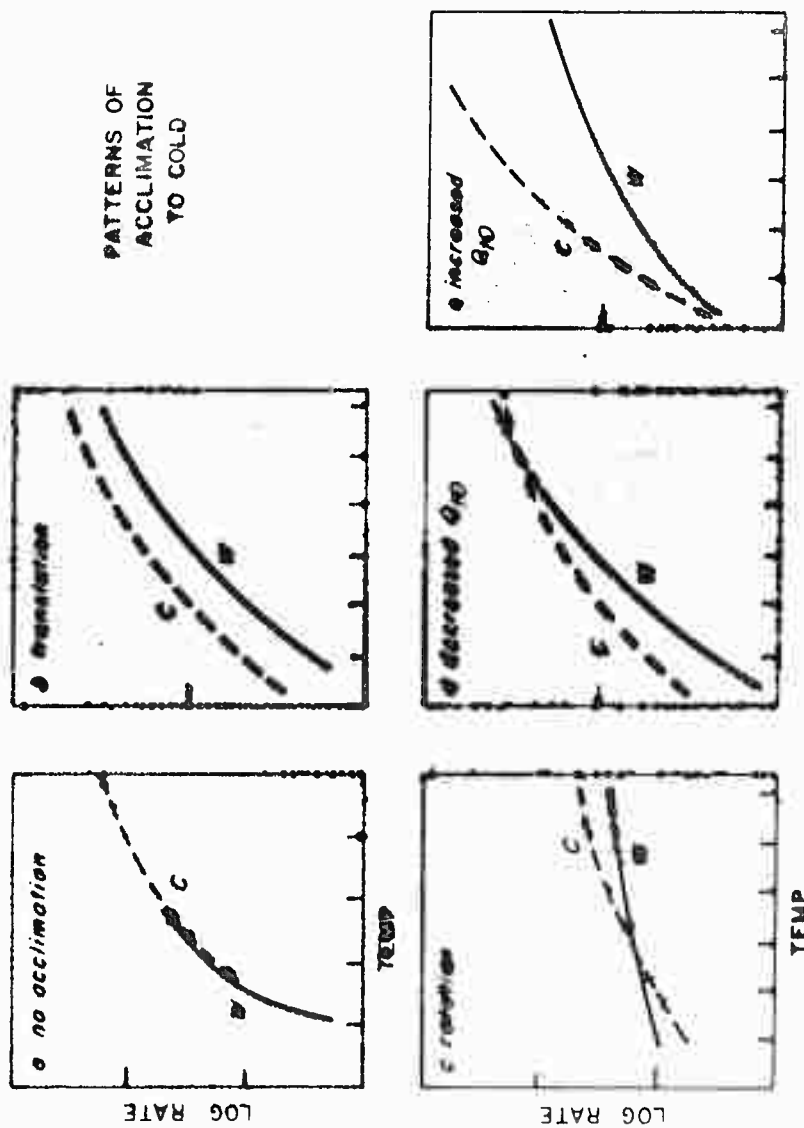

Figure 4. Patterns of acclimation of rate functions in cold. Rate functions measured at different temperatures. W, warm acclimated animals; C, cold acclimated animals.

ones, the two curves may intersect by extrapolation above the normal temperature range (Figure 4d). Examples for vertebrates are heart rate of the newt Triton (Mellanby, 1940), metabolism of cottid fish, winter and summer, northern and southern latitudes (Morris, 1961), and O_2 consumption by frogs acclimated to $5^\circ C$ and $25^\circ C$ (Riech et al., 1960). If the Q_{10} of cold-acclimated animals is higher (Figure 4e), the two curves may intersect at a low temperature, often by extrapolation. Above the intersection the rate is greater for cold-acclimated than for warm-acclimated animals. This is reported for O_2 consumption by the crucian carp acclimated to $5^\circ C$ and $26^\circ C$ (Suhrman, 1955) and for O_2 consumption by brain tissue of goldfish (Freeman, 1950).

Translation of a rate-temperature curve implies a change in activity (in a thermodynamic sense) and may be caused by change in enzyme concentration, change in the relative activities of enzymes in series or in parallel, or a change in controlling conditions---ionic strength, pH etc. Rotation of a rate-temperature curve implies a change in Q_{10} and hence in activation energy and may result from alteration of the enzymatic protein, change in some co-factor, or a shift in control of a reaction to alternate enzymatic pathways. Different tissues of the same animal may show different patterns of metabolic acclimation, e. g., the heart of goldfish shows no change, but skeletal muscle, and to a lesser degree liver, shows acclimation with a reduction of Q_{10} in the cold.

Metabolic and Enzymatic Changes

A number of selected examples of compensatory acclimation of metabolism of intact poikilothermic vertebrates is given in Table I. A greater oxygen consumption of cold- than of warm-acclimated animals when measured at intermediate temperatures is indicated for lampreys (Scherbakov, 1937), eels (Precht, 1951), marine fish Fundulus and Gellichthys (Wells, 1935a,b), goldfish for both active and standard metabolism (Kanungo and Prosser, 1959a), and frogs (Riech 1960). The extent to which photoperiod and nutritional state modify these differences is not clear, but the principal experimental variable in each experiment was temperature. When measured at the acclimation temperatures, the maximum active metabolism is lower than the maximum standard metabolism (Fry and Hart, 1948b); if

POIKILOTHERMIC ADAPTATIONS

Animal	Temperature of Measurement	Acclimation Temperature and Oxygen Consumption per Wet Weight	Per Cent by which Cold Exceeds Warm
lamprey (Scherbakov, 1937)	16°	1.5-3.5° 0.21 mgO ₂ /g _w /hr	15-17° 0.14 50%
eel (Precht, 1951)	12° 22°	11° 5 mlO ₂ /100 g _w /hr 7 mlO ₂ /100 g _w /hr	26° 2 7 150% 0%
<i>Carassius gibelio</i> crucian carp (Suhrmann, 1955)	10-11° 20-21° 29°	5° 4.4 mlO ₂ /100 g _w /hr 15.5 mlO ₂ /100 g _w /hr 24.6 mlO ₂ /100 g _w /hr	26° 3.3 6.8 18.1 37% 128% 53%
<i>Carassius carassius</i> <i>carassius</i> (Roberts, 1960)	20°	4-7° 70 mlO ₂ /kg/hr 72 mlO ₂ /kg/hr	20° 168 (7 hr day) 238 (17 hr day) 58% 89%
goldfish (Kanungo, Prosser, 1959a)	Standard 20° 25° Active 20° 25°	10° 8.7 mlO ₂ /100 g _w /hr 13.7 mlO ₂ /100 g _w /hr 11.29 mlO ₂ /100 g _w /hr 19.33 mlO ₂ /100 g _w /hr	30° 6.64 7.88 9.78 12.2 35% 74% 16% 56%
<i>Gillichthys</i> (Wells, 1935)	22°	10-12° 0.11 gms/hr	30° 0.9 22%
frog (Ruech et al., 1960)	10° 20°	5° 8 mlO ₂ /100 g _w /hr 11 mlO ₂ /100 g _w /hr	25° 3.0 7.6 166% 47%
frog (Jankowsky, 1960)	15° 25°	7° 158 mm ³ /hr/g ^{2/3} 411	25° 122 287 30% 43%

Table 1. Metabolic acclimation of intact poikilothermic vertebrates.

metabolism of animals acclimated to extreme temperatures is measured over the entire curve, the two maxima are similar (Kanungo and Prosser, 1959a) (Figure 5). Species differences may be marked as between Carassius carassius and C. gibelio (Suhrman, 1955 and Roberts, 1960); C. carassius shows an inverse or type 5 acclimation, C. gibelio a positive or type 3 acclimation.

Data for oxygen consumption by tissue slices, homogenates, and whole gills are given in Table II. There is some disagreement for the same tissue among investigators, and some tissues show more temperature compensation than do others. In general, skeletal muscle shows more change than does liver or heart. For brain, compensation is reported by two authors and lack of compensation by two. Gills of fish show marked metabolic compensation. For both gills and muscle, Roberts (1960) reports higher daytime metabolic rates and slightly greater differences between warm- and cold-acclimated tissues when the fish have been on a short day (7-hour) photoperiod than on a long day (17-hour) photoperiod. No attempt has been made to equate the O_2 consumption by various tissues to the total by the intact animal and to evaluate the relative contributions of each, but the percentage of change found for isolated tissues is less than for intact animals.

Evidence for acclimatory effects on some enzymes of poikilothermic vertebrates and not on other enzymes is summarized in Table III. The reported enzymatic effects are insufficient to account for the observed changes in metabolism. Differences in some dehydrogenases and electron transport enzymes have been reported. Gills from cold-acclimated goldfish were more sensitive to cyanide (Ekberg, 1958) (and liver more sensitive to antimycin (Kanungo and Prosser, 1959b)), while liver showed no significant differences with respect to inhibition by cyanide, azide, carbon monoxide, or amytol (Kanungo and Prosser, 1959b). Cocarboxylase showed some compensation in liver and questionable effect in muscle (Carlsen, 1953). Succinic dehydrogenase of eel liver as measured by methylene blue reduction showed considerable change (Precht, 1951). In goldfish this enzyme was altered in muscle and in liver when measured on a protein (but not on a wet weight) basis (Murphy, 1961). Malic dehydrogenase of goldfish liver showed considerable inverse acclimation (Precht's type 5) (Murphy, 1961). Cytochrome oxidase showed

POIKILOTHERMIC ADAPTATIONS

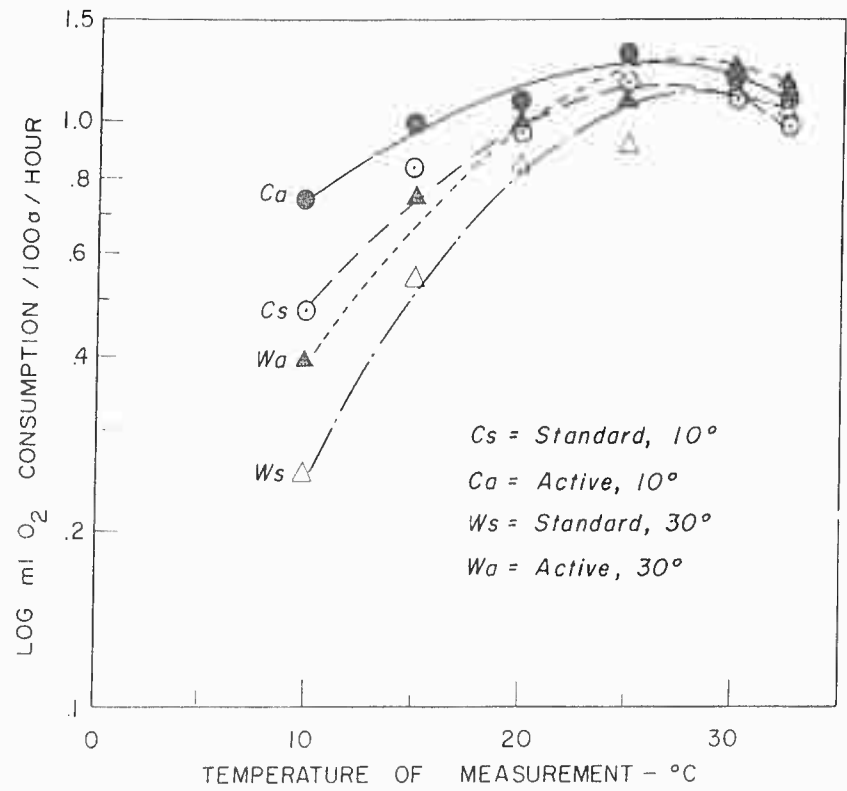

Figure 5. Oxygen consumption of goldfish measured at different temperatures. Both active and standard metabolism of fish acclimated at 10° C and at 30° C. From Kanungo and Prosser, 1959a (Fig. 1, p. 261).

PROSSER

Tissue and animal	Temperature of Measurement	Acclimation Temperature and O ₂ Consumption per Unit Weight Wet (w) or Dry (d)	Per Cent by which cold Exceeds Warm		
<u>Muscle</u>					
Crucian carp (Roberts, 1960)	20°	4-7° (7 hr day) 260 mm ³ /g _w /hr	20° (7 hr) 201	44%	
	20°	4-7° (17 hr day) 197	186	38%	
sunfish (Roberts, 1961)	25°	20° 0.073 μl O ₂ /mg _w /hr	25° 0.097	88%	
goldfish (Murphy, 1961)	20° succinate	5° (12 hr day) 862 μl O ₂ /mg _w /hr (6-8 days)	20° 888	n.s.	
		20° glucose	814 (23-25 days) 536 (6-8 days) 667 (30-35 days)	896 816 880	83% n.s. 149%
	frog (R. pipiens) (Riech et al., 1960)	25°	20° 160 mm ³ /g _w /hr	25° 179	64%
		30°	25° 640 mm ³ /g _w /hr	25° 618	n.s.
<u>Gills</u>					
goldfish (Ekberg, 1958)	10° (Feb.)	12° 0.897 μl O ₂ /mg _w /hr	20° 0.100	143%	
	18° "	0.687 μl O ₂ /mg _w /hr	0.293	113%	
	26° "	1.076 μl O ₂ /mg _w /hr	0.522	106%	
Crucian carp (Roberts, 1960)	20°	4-7° (7 hr day) 701 mm ³ /g _w /hr	20° (7 hr day) 365	28%	
	20°	4-7° (17 hr day) 618	20° (17 hr) 489	26%	

Table II. Oxygen consumption by tissues (usually with glucose) from poikilothermic vertebrates acclimated at different temperatures. (n.s., not significant)

POIKILOTHERMIC ADAPTATIONS

Tissue and Animal	Temperature of Measurement	Acclimation Temperature and O ₂ Consumption per Unit Weight Wet (w) or Dry (d)		Per Cent by which Cold Exceeds Warm
<u>Liver</u> goldfish (Ekberg, 1958)	10°	10°	0.621 $\mu 10_2/mgd/hr$	37%
	22°		1.369	64%
	30°		1.44	n.s.
goldfish (Kanungo, Prosser 1958)	20°	10°	1.2 $\mu 10_2/mgd/hr$	43%
goldfish (Murphy, 1951)	15°	5°	363 $\mu 10_2/g_w/hr$	n.s.
	20°		697 $\mu 10_2/g_w/hr$	n.s.
frog (Riech et al., 1960)	25°	5°	320	n.s.
25°		25°	300	n.s.
<u>Brain</u> sunfish (Roberts, 1951)	20°	10°	0.519 $\mu 10_2/mgd/hr$	n.s.
			0.521	n.s.
goldfish (Freeman, 1953)	19.5°		9 $\mu gO_2/g_w/min$	80%
goldfish (Ekberg, 1958)	22°	10°	1.53 $\mu l/mgd/hr$	n.s.
		30°	1.5	n.s.
<u>Heart</u> goldfish (Murphy, 1951)	10°	5°	530 $\mu 10_2/g_w/hr$	n.s.
	20°		868 $\mu 10_2/g_w/hr$	n.s.
	30°		1744 $\mu 10_2/g_w/hr$	n.s.
frog (Riech et al., 1960)	25°	5°	225 $\mu 10_2/g_w/hr$	n.s.?
		25°	300	n.s.?

PROSSER

Oxidative Enzymes	Temperature of Measurement	Acclimation Temperature and Enzyme Activity Per gm Wet Weight or mg Protein		Per Cent by which Cold Exceeds Warm
		Cold	Warm	
Succinic dehydrogenase				
eel liver		11 ^o	26 ^o	
(Precht, 1951)		.43	.24	79%
goldfish liver		5 ^o	30 ^o	
(Murphy, 1961)	15 ^o	15.9 μ l/g _w /min	14.3	n.s.
	25 ^o	17 μ l/g _w /min	19.9	n.s.
goldfish muscle		8.11 μ 10 ₂ /g _w /min	6.64	21%
(Murphy, 1961)				
Coccarboxylase				
eel liver		440	345	26%
(Carlsen, 1953)				
eel muscle		390	367	n.s.?
(Carlsen, 1953)				
Malic dehydrogenase				
goldfish liver		5 ^o	30 ^o	
(Murphy, 1961)	15 ^o	9.15 μ 10 ₂ /g _w /hr	16.2	-44%
	20 ^o	14.7 μ l/g _w /min	22.5	-34.5%
Cytochrome c oxidase				
goldfish liver		5 ^o	30 ^o	
(Murphy, 1961)	15 ^o	15.0 μ l/g/min	15.9	n.s.
	25 ^o	23.4 μ l/g _w /min	22.8	n.s.
		.236 μ l/mg _{pr} /min	.183	29.5%
goldfish muscle		13.9 μ 10 ₂ /g _w /min	12.3	n.s.
(Murphy, 1961)				
DPNH cytochrome reductase				
goldfish liver		5 ^o	30 ^o	
(Murphy, 1961)		23.5 g _w	29.9/g _w	n.s.
TPNH cytochrome reductase				
goldfish liver		5 ^o	30 ^o	
(Murphy, 1961)		4.13 g _w	4.97/g _w	n.s.
Catalase				
carp gill		5 ^o	25 ^o	
(Ekberg, 1961)		219.7	223.7	n.s.
eel liver		5 ^o	77	-35%
(Precht, 1951)				
CN inhibition				
goldfish gill		10 ^o	30 ^o	
(Ekberg, 1958)		79.1% inhib.	57.5%	
goldfish liver		85.9%	81.2%	n.s.
(Ekberg, 1958)				
goldfish liver				
(Kanungo, Prosser, 1959)				

No significant difference in inhibition by CO, CN, azide.

POIKILOTHERMIC ADAPTATIONS

Hexose monophosphate shunt enzymes	Acclimation Temperature and Enzyme Activity Per gm Wet Weight or mg Protein		Per Cent by which Cold Exceeds Warm
	Cold	Warm	
Glucose - 6-PO ₄ dehydrogenase			
Crucian carp gill (Ekberg, 1961)	5 ^o 44.2 arb. units	25 ^o 43.9	n.s.
goldfish liver (Murphy, 1961)	5 ^o 0.298	30 ^o 0.548	-46%
6 - PO ₄ - gluconic dehydrogenase			
Crucian carp gill (Ekberg, 1961)	5 ^o 11.0 arb. units	25 ^o 4.7	134%
goldfish liver (Murphy, 1961)	5 ^o 0.041	30 ^o 0.034	n.s.
Glycolytic enzymes			
Aldolase			
Crucian carp gill (Ekberg, 1961)	5 ^o 96.3	25 ^o 64.3	50%
Anaerobic acid production			
Crucian carp gill (Ekberg, 1961)	5 ^o 263 (7 hr. day) 326 (17 hr. day)	25 ^o 176 (7 hr. day) 194 (17 hr. day)	49% 68%
Lactic dehydrogenase			
goldfish liver (Murphy, 1961)	5 ^o 1893/g _w 19.10/mg _{pr}	30 ^o 1415/g _w 11.3 mg _{pr}	n.s. 65%
IOA inhibition			
goldfish gill (Ekberg, 1959)	10 ^o 52.6% inhib.	30 ^o 77.4% inhib.	

Table III. Activity of enzymes from poikilothermic vertebrates acclimated in different temperatures. (-- Values, inverse acclimation, or Precht's Type 5). (n.s. not significant). Enzyme activities in different units of measurement.

PROSSER

either no effect or a very slight compensation and goldfish liver has no such excess of cytochrome oxidase as rat liver (Murphy, 1961). Catalase showed no change (*Carassius* gill, Ekberg, 1961) or an inverse or type 5 acclimation (eel liver, Precht, 1951). No differences between warm- and cold-acclimated goldfish were found for DPNH reductase and TPNH cytochrome reductase (Murphy, 1961). Wide variability in P/O ratios led to equivocal results (Kanungo and Prosser, 1959a; Murphy, 1961).

The enzymes of the hexose monophosphate shunt show very low activity in fish, and their importance is doubtful (Brown, 1960). For example, the activity of glucose-6-phosphate dehydrogenase in goldfish liver is only 3% of that in rat liver (Murphy, 1961). This enzyme showed no compensation in crucian carp gill (Ekberg, 1961) and an inverse (type 5) acclimation in goldfish liver (Murphy, 1961). Another enzyme of the shunt, 6-phospho-gluconic dehydrogenase, showed a large compensation in crucian carp gills, but no change in goldfish liver homogenates. The suggestion (Kanungo and Prosser, 1959b) that there might be increased use of the monophosphate shunt in the cold seems invalid.

The most important metabolic changes in acclimation to cold seem to be in glycolytic enzymes. Sluggish fish such as carp are said to survive anaerobically in the cold (Blazka, 1958). Active fish such as the Kamloops trout show an increase in lactic acid concentration in muscle of as much as 4 1/2 times in 9 minutes of exercise and elevated lactic acid persisted for several hours post-exercise (Black et al., 1960, 1961). Blood lactate in unexercised trout and salmon is high in comparison with mammals and may rise as much as 6 to 10 fold after exercise (Black et al., 1960). Pyruvate follows the same time course as lactate. A trout accumulates lactic acid and pays off an O_2 debt (Black et al., 1960); a crucian carp does not accumulate lactate but increases its CO_2 excretion (Blazka, 1958). It appears that fish rely considerably on glycolytic metabolism. Lactic dehydrogenase activity is high in goldfish liver, and it shows some temperature compensation (Murphy, 1961). Total acid production by crucian carp gills was elevated in cold-acclimation, but the CO_2 production was not (Ekberg, 1961). Aldolase was markedly increased in carp gills by cold acclimation (Ekberg, 1961). Iodoacetate sensitivity of goldfish gills was less in the cold. It appears that the most

POIKILOTHERMIC ADAPTATIONS

striking enzymic increases in fish tissues in the cold are in those of glycolysis. However, intermediate acids must ultimately be oxidized and the relatively small changes in electron transport enzymes are difficult to explain.

The preceding evidence indicates that some enzymes change and others are unaltered in the compensatory acclimation of fish, that corresponding enzymes differ for different tissues, and that enzymes may either increase or decrease according to temperature. The meaning of inverse acclimation (e. g., malic dehydrogenase in goldfish liver and catalase in eel liver) is not clear. In general, the more an animal is taken apart, the less is the apparent acclimation. In our laboratory Murphy recently examined the activity of numerous enzymes of goldfish liver and has had difficulty obtaining statistically significant differences between those from cold- and warm-acclimated fish. The range of variability is very great for those genetically heterogeneous fish and reproducibility of experiments poor. Certainly there is no evidence for a general change in activity of all metabolic systems, and major effects are probably in the integration of metabolism.

Non-enzymatic Chemical Changes

Other changes besides those in enzymes of intermediary metabolism have been noted in cold-acclimation. Changes in water content may be significant for marine fish. At 1.6° C in sea-water the tide-pool fish *Girella* lost 23% of their water, and they survived only 2 days, whereas in 45% sea-water at the same temperature no water loss was observed and survival was prolonged (Doudoroff, 1938). In fresh-water fish, however, an increase of 2% in water content was reported for goldfish after 2 days at 4° C (Meyer et al., 1956) and a decrease after 25 days at 5° C (Hoar and Cottie, 1952). Goldfish liver showed no significant difference in water content for 5° C and 30° C acclimation (Murphy, 1961).

Protein content of liver from goldfish acclimated at 5° C was 9.9% and from those at 30° C was 12.5% (Murphy, 1961); no change was found in the protein content of muscle.

Changes in lipids have been reported. Acclimation of goldfish to cold was accompanied by increased unsaturation of tissue lipids and acclimation to heat by a decreased unsaturation (Hoar and Cottle, 1952). In cold the tissue phospholipids of goldfish increased in relation to cholesterol, but no consistent correlation was observed between the ratio of cholesterol to phospholipid and thermal resistance. Also no good correlation was found between dietary lipid unsaturation and thermal resistance, although a high cholesterol diet increased resistance to both heat and cold (Irvine et al., 1957). Preliminary observations indicate a higher percentage of stearic and palmitic acids in liver of 30° C-acclimated than of cold-acclimated goldfish (Murphy and Johnston, 1961). Liver of goldfish from 5° C had 1.76% lipid, from 30° C had 3.97% lipid. The iodine numbers were as follows: 30° C, 97.7; 15° C, 100.3; 5° C, 102.3; hence the liver lipid is more unsaturated in the cold-acclimated state. Similar changes were noted by Hoar and Cottle (1952). In view of the central nervous changes to be reported below, it is likely that numerous changes in the lipids of cell membranes will be found.

What mechanisms underly biochemical changes? Changes in lipids must depend on differences in some synthetic enzymes. As stated above, there is no evidence for involvement of the adrenal cortex and conflicting evidence for involvement of the thyroid in temperature acclimation of poikilothermic vertebrates. Much more work should be done on possible hormonal regulation of metabolism. However, present evidence favors a direct effect of temperature. This could occur in several possible ways: (1) In the cold, the total metabolism is lower than at high acclimation temperatures; hence metabolic substrates in general may accumulate, and these may induce more intermediary enzymes at several levels. (2) an intermediate such as pyruvate (or lactate) may accumulate because its degradative enzymes have a higher Q_{10} than those enzymes forming it, and thus this intermediate may reach concentrations which induce an alternate path. If $B \gg C$, in the system:

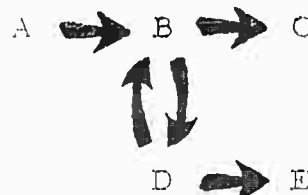

has a high Q_{10} , B accumulates and may induce the enzyme catalyzing

POIKILOTHERMIC ADAPTATIONS

B ⇨ D. (3) An accumulation of products of one step can repress or can stimulate an earlier step in a sequence. The actions (2) and (3) may be on enzyme-forming RNA or even on the DNA template. In nature the capacity of a particular enzyme-forming system to change can form the basis for selection under temperature stress.

The biological significance of the chemical changes in temperature acclimation is uncertain. Many enzymes show enhanced activity, some are unaltered, and a few decreased in action after cold acclimation. No calorimetric measurements of total energy liberation have been made, and determination of P/O ratios for liver mitochondria have led to equivocal results. The lipid changes are in the direction of lower melting points in the cold. A fish or a salamander at a low temperature is never as active as at a high temperature.

Behavior and nervous changes

In a temperature gradient a fish "selects" a temperature where the frequency of spontaneous movements is least; this selection is determined by sensory input from cutaneous thermoreceptors and is upset by lesions of the forebrain (Sullivan, 1954; Fisher, 1958). The "selected" temperature is higher than a low temperature of acclimation and lower than a high acclimation level (Sullivan and Fisher, 1953, 1954), and shifts according to acclimation (Fry and Hart, 1948a). When maximum swimming speed is measured at different temperatures, the optimal temperature rises (Fry and Hart, 1948a), and the temperature at which active swimming stops is higher (Roots, 1961) as the acclimation temperature rises.

The O_2 consumption measured in maximum swimming activity rises with temperature more rapidly over a low temperature range and then more slowly than does the standard or rest metabolism (Figure 6). The difference between the two curves (active and standard) for fully acclimated fish is considered a measure of extra energy available for swimming, the "scope of activity" of Fry. This difference curve or scope of activity rises to a maximum in lake trout (*Salvelinus*) at a temperature close to that of maximum cruising speed (Gibson and Fry, 1954), and it has been suggested that the maximum motor activity is determined by the energy available to

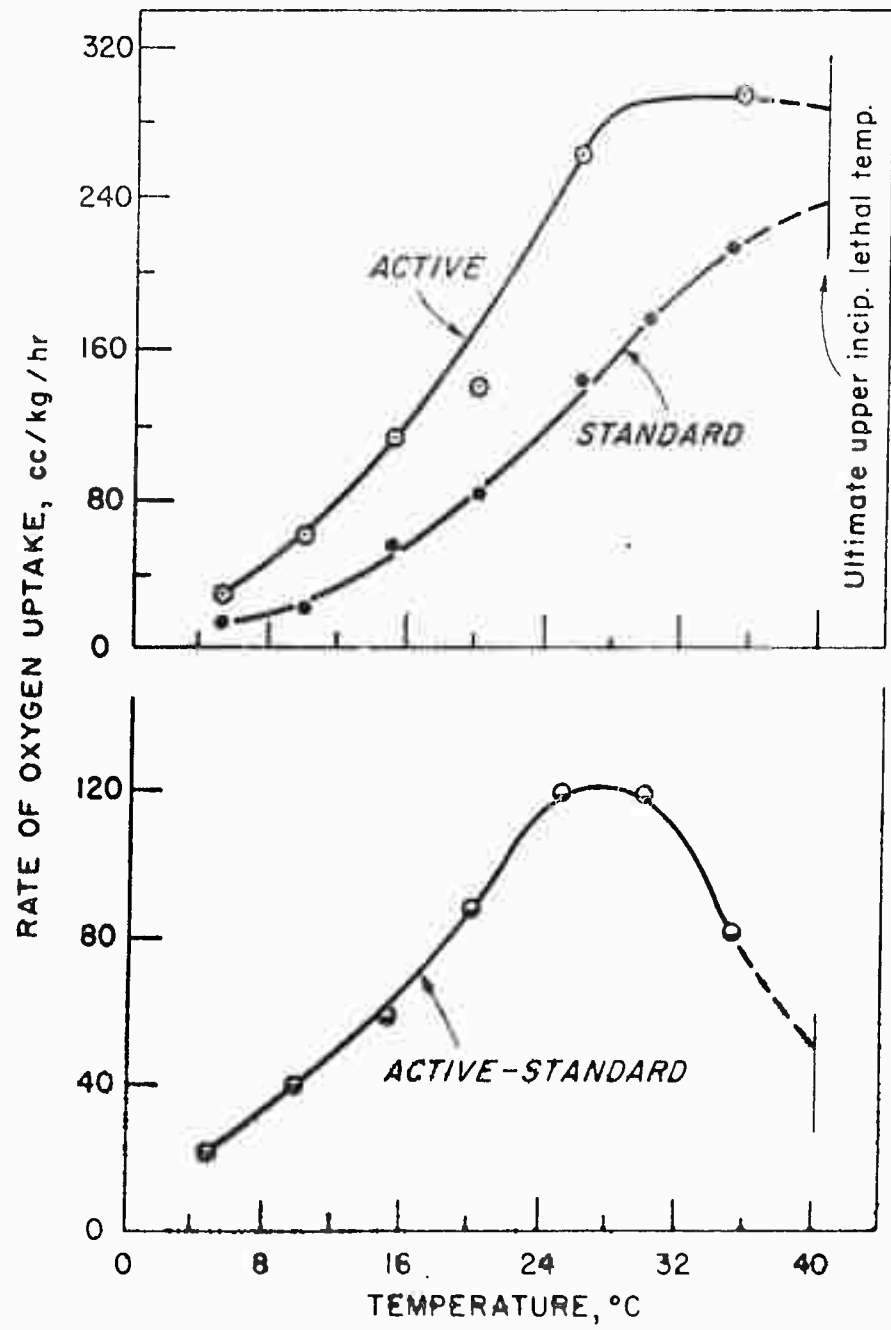

Figure 6. Active and standard metabolism and the difference between them when measured at the temperatures of acclimation. From Fry and Hart, 1948 (Fig. 5, p. 73).

POIKILOTHERMIC ADAPTATIONS

the fish (Fry, 1947). The change after acclimation of the temperature at which swimming is maximum is, according to this view, due to compensatory metabolic alterations such as have been described above. Certainly no animal can move more rapidly than energy can be made available to it. Fisher (1958) has questioned whether the maximum metabolism per se determines the cruising speed or whether the limit may be imposed in the nervous system. It is possible to increase oxygen consumption beyond that at maximum cruising speed by electrical stimulation (Basu, 1959). Some fish (trout) show two temperature optima for cruising, and these can be altered by brain lesions; swimming rate is affected by light intensity (Fisher, 1958). It appears, therefore, that available energy is not the only limiting factor for activity.

In addition to changes in the temperature preferendum and temperature of maximum cruising speed with acclimation, or the temperature of sudden reduction in swimming, other measurements indicate adaptive alterations in the central nervous system. Conduction in peripheral nerves is blocked by cold, and the critical temperature for cold block declines with cold acclimation (Roots, 1961). Spinal reflex movement of the fins of goldfish was blocked at 10° C, 5° C, and 1° C respectively for fish acclimated to 35° C, 25° C, and 15° C; the reflex persisted at below 1° C in fish acclimated to 5° C. Roots has conditioned fish to avoid either a light or dark end of a divided aquarium, and also to interrupt their breathing rhythm when given a visual stimulus. The cold-blocking temperatures of these conditioned reflexes is higher than for simple reflexes, e. g., block occurs at 15° C for 25° C-acclimated fish. Thus a hierarchy of temperature sensitivity is found, with midbrain functions most sensitive, spinal functions less so, and peripheral nerve least sensitive to cold (Roots, 1961).

Similarly in two species of skate (Raja) sensitivity of nerve and muscle to heat decreases in the following series: myoneural junction, nerve conduction, striated muscle contraction, and heart and gut muscle activity (Battle, 1926). It is concluded that important adaptive changes occur in the nervous system during temperature acclimation. Changes in nervous function reflect chemical alterations of excitable membranes and subtle changes in interneuronic interaction which are totally unknown. In the absence of the insulative

changes which occur in homeotherms, the nervous changes underlying behavior are of particular importance in poikilotherms.

Resistance to Temperature Extremes

In nature, the adaptations favoring survival at extremes of heat or cold may be more important than compensations in the mid-range. Some geographic races of fish (e. g., Salvelinus alpinus) have been shown to differ in their lethal temperatures but not in temperatures of maximum cruising speed (McCauley, 1958). The literature on change of lethal temperature with acclimation is extensive (Brett, 1956), but very little is known of the responsible cellular changes. Some organs are more sensitive than others; for example, the brain is more sensitive than the heart, but the chemical bases for such differences are unknown. Differences in inactivation temperatures have been observed for some enzymes from thermophilic and mesophilic bacteria (Koffler, 1957), and the inactivation temperature for amylases, pepsin, and trypsin from fish is lower than for the same enzymes from mammals (Chesley, 1934; Vonk, 1941). Acetylcholine acetylase of a fish (Labrus) brain is maximally active at 25° C and is inactivated at 37° C, whereas corresponding temperatures for the same enzyme from rabbit brain are 42° C and 47° C respectively (Milton, 1958). Changes in lipids as shown by their melting points may be important for cell permeability. The effect of endocrines, such as the thyroid, on heat death was mentioned above. It may well be that more marked changes occur in resistance to temperature extremes than as metabolic compensations within the normal range, and there may be little relation between the compensations of capacity adaptation and the stress responses of resistance adaptation.

CONCLUSIONS

Acclimation of poikilothermic vertebrates to temperature is basically different from that in homeotherms in that compensations of poikilotherms tend toward maintenance of relatively constant

POIKILOTHERMIC ADAPTATIONS

metabolism and behavior with changing body temperature, whereas the acclimation of homeotherms tends toward maintenance of constant body temperature. Some poikilotherms show no compensations, but their body processes remain slow (as in hibernation) at low temperatures.

No consistent pattern is yet evident for biochemical changes. According to in vitro measurements, some enzymes appear to compensate; many do not. Glycolysis may be most affected in fish. The meaning of lipid changes is not clear, although lower melting points in the cold are found in fish as well as in peripheral fat of mammals.

The integrated metabolic system of intact animals shows more consistent compensation than isolated enzymes. Undoubtedly hormones are important in acclimation, as shown by the effects of photoperiod. However, there is evidence for direct effects of temperature, possibly through some sort of enzyme induction. Marked differences occur in the response of different organs and tissues to temperature.

Behavioral compensations reflect a hierarchy of differences in nervous adaptations with complex conditioned responses being most sensitive and peripheral nerve conduction least. These changes in sensitivity of nervous systems to cold might be related to alterations in membrane lipids.

Changes in resistance to extreme temperature stress are clearly indicated by decline in temperatures of both heat and cold death with reduced acclimation temperature. Mechanisms of changes in resistance to temperature extremes are unknown as are the relations between compensation (capacity) acclimation and resistance acclimation.

LITERATURE CITED

1. Auerbach, M. 1957. Hat die Schilddrüse für die Temperaturadaptation der Fische eine Bedeutung? Ztsch. f. Fisch. Hilfswiss. 6:605-620.
2. Barrington, E. J. N. and A. J. Matty. 1954. Seasonal variation in the thyroid gland of the minnow, Phoxinus phoxinus with some observations on the effect of temperature. Proc. Zool. Soc. Lond. 124:89-95.
3. Basu, S. P. 1959. Active respiration of fish in relation to ambient concentrations of oxygen and CO₂. J. Fish. Res. Bd. Canada. 16:175-212.
4. Battle, H. I. 1926. Effects of extreme temperatures on muscle and nerve tissue in marine fish. Trans. Roc. Soc. Canada Ser. III, Sec. V, 20:127-143.
5. Berg, O., A. Gorbman, and H. Kobayashi. 1959. Thyroid hormones in invertebrates and lower vertebrates. In Comparative Endocrinology, [Ed.], A. Gorbman, (Wiley, New York), pp. 302-319.
6. Black, E. C., A. C. Robertson, A. R. Hanslip, and W. Chin. 1960. Alterations in glycogen, glucose, and lactate in rainbow and Kamloops trout, Salmo gairdneri, following muscular activity. J. Fish. Res. Bd. Canada 17:487-500.
7. Black, E. C., A. C. Robertson, and R. R. Parker. 1961. Some aspects of carbohydrate metabolism in fish. In Compar. Physiol. in Heterothermic Animals, [Ed.], A. W. Martin, (U. Washington, Seattle), pp. 89-124.
8. Blazka, P. 1958. Anaerobic metabolism of fish. Physiol. Zool. 31:117-128.

POIKILOTHERMIC ADAPTATIONS

9. Brett, J. R. 1956. Principles of thermal requirements of fish. *Quart. Rev. Biol.* 31:75-87.
10. Brown, W. D. 1960. Glucose metabolism in carp. *J. Cell. Comp. Physiol.* 55:81-85.
11. Brown, W. D. and A. L. Tappel. 1959. Fatty acid oxidation by carp liver mitochondria. *Arch. Biochem. Biophys.* 85:149-158.
12. Carlsen, H. 1953. Die cocarboxylasegehalt des Aales (Anguilla vulgaris). *Ztsch. vergl. Physiol.* 35:199-208.
13. Chesley, L. C. 1934. Influence of temperature upon the amylases of cold- and warm-blooded animals. *Biol. Bull.* 66:330-338.
14. Dawson, W. R. and G. A. Bartholomew. 1956. Relation of oxygen consumption to body weight, temperature, and temperature acclimation in lizards Uta stansburiana and Sceloporus occidentalis. *Physiol. Zool.* 29:40-51.
15. Doudoroff, P. 1938. Resistance and acclimatization of marine fishes to temperature changes. I. Experiments with Girella nigrisans. *Biol. Bull.* 83:219-244.
16. Ekberg, D. R. 1958. Respiration in tissues of goldfish adapted to high and low temperatures. *Biol. Bull.* 114:308-316.
17. Ekberg, D. R. 1961. In press.
18. Fisher, K. C. 1958. An approach to the organ and cellular physiology of adaptation to temperature in fish and small mammals. In *Physiol. Adaptation*, [Ed.], C. L. Prosser, (Am. Physiol. Soc., Washington, D. C.), pp. 3-49.
19. Freeman, J. A. 1950. Oxygen consumption, brain metabolism and respiration movements of goldfish during temperature acclimatization; with special references to lowered temperature. *Biol. Bull.* 99:416-424.

20. Fry, F. E. J. 1947. Effects of the environment on animal activity. Publ. Ont. Fish. Res. Lab. (Univ. of Toronto Studies Biol. Series 55), 68:1-62.
21. Fry, F. E. J. and J.S. Hart. 1948a. Cruising speed of goldfish in relation to water temperature. J. Fish. Res. Bd. Canada 7: 169-175.
22. Fry, F. E. J. and J. S. Hart. 1948b. Relation of temperature to oxygen consumption in goldfish. Biol. Bull. 94:66-77.
23. Fry, F. E. J., J. S. Hart, and K. F. Walker. 1946. Lethal temperature relations for a sample of young speckled trout, Salvelinus fontinalis. Publ. Ont. Fish. Res. Lab. (Univ. Toronto Studies Biol. Ser. 54), 66:1-35
24. Gelineo, S. 1959. Temperature d' adaptation et consommation d' oxygène chez la scorpène truie Scorpaena porcus. Bull. XXV Acad. Serb. d. Sci., pp. 37-40.
25. Gibson, E.S. and F. E. J. Fry. 1954. The performance of the lake trout Salvelinus namaycush at various levels of temperature and oxygen pressure. Canad. J. Zool. 32:252-260.
26. Hannon, J.P. 1960. Intermediary glucose metabolism in the cold-acclimatized rat. Fed. Proc. 19, Suppl. 5:100-105.
27. Hart, J.S. 1957. Climatic and temperature induced changes in the energetics of homeotherms. Rev. Can. de Biol. 16:133-174.
28. Heroux, O. 1960. Adjustments of the adrenal cortex and thyroid during cold acclimation. Fed. Proc. 19, Suppl. 5:82-85.
29. Hoar, W. S. 1955. Seasonal variations in the resistance of goldfish to temperature. Trans. Roy. Soc. Canada (Series 3), 49: 25-34
30. Hoar, W. S. 1959. Endocrine factors in ecological adaptation of fishes. In Comp. Endocrinol., [Ed.], A. Gorbman, (Wiley, New York), pp. 1-23.

POIKILOTHERMIC ADAPTATIONS

31. Hoar, W. S. and M. K. Cottle. 1952. I. Dietary fat and temperature tolerance of goldfish. II. Some effects of temperature acclimatization on the chemical constitution of goldfish tissues. *Can. J. Zool.* 30:41-48, 49-54.
32. Hoar, W. S. and G. B. Robertson. 1959. Temperature resistance of goldfish maintained under controlled photoperiod. *Can. J. Zool.* 37:419-428.
33. Irvine, D. G., K. Newman, and W. S. Hoar. 1957. Effects of dietary phospholipid and cholesterol on the temperature resistance of goldfish. *Can. J. Zool.* 35:691-709.
34. Jones, S. C., J. G. Phillips, and W. N. Holmes. 1959. Comparative Physiology of the adrenal cortex. In *Comp. Endocrinol.*, [Ed.], A. Gorbman, (Wiley, New York), pp. 582-623.
35. Kanungo, M. S. and C. L. Prosser. 1959a. Standard and active oxygen consumptions of cold- and warm-acclimated goldfish at various temperatures. *J. Cell. Comp. Phys.* 54:259-264.
36. Kanungo, M. S. and C. L. Prosser. 1959b. Oxygen consumption of liver homogenate; oxygen consumption and oxidative phosphorylation of liver mitochondria. *J. Cell. Comp. Physiol.* 54:265-274.
37. Koffler, H. 1957. Protoplasmic differences between mesophiles and thermophiles. *Bacteriol. Rev.* 21:227-240.
38. Martin, G. and K. L. A. Tarr. 1961. Phosphoglucomutase, phosphoribomutase and phosphoglucoisomerase of lingcod muscle. *Can. J. Biochem. Physiol.* 39:297-308.
39. McCauley, R. W. 1958. Thermal reactions of geographic races of *Salvelinus*. *Can. J. Zool.* 36:655-662.
40. Mellanby, K. 1940. Temperature coefficients and acclimation. *Nature* 146:165-166.

PROSSER

41. Meyer, D. K., B. A. Westfall, and W. S. Platner. 1956. Water and electrolyte balance of goldfish under conditions of Anoxia, cold and inanition. *Am. J. Physiol.* 184:553-556.
42. Milton, A. S. 1958. The effect of temperature on the synthesis of acetylcholine by the enzyme choline acetylase from mammalian and fish brain. *J. Physiol.* 142:25.
43. Morris, R. W. 1961. Distribution and temperature sensitivity of some eastern Pacific cottid fishes. *Physiol Zool.* 34:217-227.
44. Murphy, B. 1961. Tissue metabolism of goldfish (Carassius auratus) acclimated to warm and cold temperatures. Ph. D. Thesis, Univ. of Ill.
45. Murphy, B. and P. Johnston. 1961. Unpublished results.
46. Olivereau, M. 1955a. Hormone thyroïdienne et température chez la truite arc-en-ciel (Salmo gairdnerii) et l'anguille (Anguilla anguilla). *Arch. d' Anat. Mic. e. Morph. Exper.* 44:236-264.
47. Olivereau, M. 1955b. Temperature et fonctionnement thyrôidien chez les Poissons. *J. de Physiol. Paris* 47:256-258.
48. Olivereau, M. 1955c. Influence de la température sur le fonctionnement thyrôidien de la truite étudié à l'aide de l'iode radioactif. *Compl. rend. Soc. Biol.* 149:536-539.
49. Precht, H. 1951. Der Einfluss der temperatur auf die atmung und auf einige Fermente beim all (Anguilla vulgaris). *Biol. Zbl.* 70:71-85.
50. Precht, H., J. Christophersen, and H. Hensel. 1955. *Temperatur und Leben.* (Springer, Heidelberg).
51. Precht, H. 1956. Einige Versuche zur temperaturabhängigkeit von Lebensprozessen der Hefe Torulopsis kefyri. *Biol. Zbl.* 75:689-705.

POIKILOTHERMIC ADAPTATIONS

52. Precht, H. 1958. Concepts of the temperature adaptation of unchanging reaction systems of cold-blooded animals. In *Physiological Adaptation*, [Ed.], C. L. Prosser, (Am. Physiol. Soc. Washington, D. C.), pp. 50-78.
53. Prosser, C. L. 1958. The nature of physiological adaptation. In *Physiological Adaptation*, [Ed.], C. L. Prosser, (Am. Physiol. Soc., Washington, D. C.), pp. 167-180.
54. Prosser, C. L. 1961. Temperature. In *Comparative Animal Physiology* by C. L. Prosser and F. A. Brown, (Saunders, Philadelphia), pp. 238-284.
55. Riech, A. , J. A. Belli, and M. E. Blaskovics. 1960. Oxygen consumption of whole animals and tissues in temperature-acclimated amphibians. *Proc. Soc. Exper. Biol. Med.* 103:436-439.
56. Roberts, J. L. 1960. The influence of photoperiod upon thermal acclimation by the crucian carp Carassius carassius. *Verh. Deutsch. Zool. Gesellsch. Bonn*, pp. 73-78.
57. Roberts, J. L. 1961. Preliminary results, by personal communication.
58. Roots, B. I. 1961. Temperature acclimation in the nervous system of fish; abstract. *Fed. Proc.* 20:209.
59. Scherbakov, A. P. 1937. Respiration and temperature adaptation in the river lamprey. *Bull. de Biol. and Medicin Exper. (U. S. S. R.)*, 3:268-270.
60. Suhrmann, R. 1955. Weitere Versuche über die temperaturadaptation der Karauschen (Carassius vulgaris). *Biol. Ztbl.* 74: 432-448.
61. Sullivan, C. M. 1954. Temperature reception and responses in fish. *J. Fish. Res. Bd. Canada* 11:153-170.

PROSSER

62. Sullivan, C. M. and K. C. Fisher. 1953. Seasonal fluctuations in the selected temperature of speckled trout, Salvelinus fontinalis. J. Fish. Res. Bd. Canada 10:187-195.
63. Sullivan C. M. and K. C. Fisher. 1954. Effects of light on temperature selection in speckled trout Salvelinus fontinalis. Biol. Bull. 107:278-288.
64. Tashian, R. E. 1957. The relation of oxygen consumption to temperature in some tropical, temperate and boreal anuran amphibians. Zoologica 42:63-68.
65. Vernberg, F. J. 1952. The oxygen consumption of two species of salamanders at different seasons of the year. Physiol. Zool. 25:243-249.
66. Vonk, H. J. 1941. Die verdauung bei die niederen vertebraten. Adv. in Enzymol. 1:371-417.
67. Wells, N. A. 1935a. Variations in the respiratory metabolism of the Pacific killifish Fundulus parvipinnis, due to size, season and continued constant temperature. Physiol. Zool. 8:318-336.
68. Wells, N. A. 1935b. Oxygen consumption by the mud sucker Gillichthys mirabilis. Biol. Bull. 69:361-367.

POIKILOTHERMIC ADAPTATIONS

DISCUSSION

HUDSON: Dr. Prosser, do you see any significance in the lower blocking temperature of the peripheral nerves compared with the higher parts of the CNS, since functionally, as far as the animal is concerned, if the cord is not responding it would not do any good to have the nerves responding?

PROSSER: I am not sure that I can give you any offhand answer. Certainly, the complex behavior which permits feeding and escape from predators would be very necessary for survival. Perhaps this means merely that integration is the important thing. This cold-hardiness of peripheral nerves has been seen before; synaptic transmission shows cold block at a higher temperature than nerve conduction.

ADAMS: Dr. Prosser, do you see any change in the lower lethal temperature in poikilothermic vertebrates as a result of acclimation to higher temperatures, or the converse? One of the questions, of course, in homeothermic literature is the inter-relationship of cold and heat acclimatization.

PROSSER: Yes, Precht has reported cases where acclimation occurred in both directions. But the curves of Fry and his associates are quite clear in showing a change in the lower lethal temperature with acclimation which may or may not be parallel to the change in the high lethal temperature. Both of his curves shift in the same direction.

HART: Do lower lethal and upper lethal temperatures both change in the same direction?

PROSSER: Yes. I wish we knew more about the mechanism of this process. I have a feeling that we need to use stress tests. We have been looking at changes in the tolerated mid-range of temperature. There are virtually no data on the critical temperatures of enzyme functions. We know very little about changes in denaturation temperatures. Dr. Jansky is doing something with this and might want to comment on it.

PROSSER

I should say in respect to the mechanisms of acclimation that there has been some indication that one can change the temperatures of inactivation of enzymes. The prize example of this is in the thermophilic bacteria, where Koffler* and others have shown that the cytochromes function at temperatures up to 70° C, whereas the corresponding proteins from mesophils are knocked out at 35° C. This is a fantastic difference. It must mean that there is a difference in tertiary structure in the same enzyme protein.

HART: I wanted to ask you about those curves which you showed of activity metabolism versus temperature--was it for the green sunfish, which is a different species, or was it for the goldfish you showed?

PROSSER: The activity curve that I showed you was for the green sunfish. Your curves have been for goldfish and they were smaller goldfish than we used. We have not been able to get such complete curves for the goldfish; that was the reason I did not show you goldfish data. We have some curves, but for some reason we have not had as good luck getting complete swimming curves for them as for the green sunfish.

HART: Those are beautiful curves. These curves agree with the general concept that Fry developed, which is that the activity would be determined by the difference between standard and active metabolism.

PROSSER: Yes, I think that is so.

HART: I wondered if you had any data on the resting versus active metabolism to compare with those active metabolism data?

PROSSER: Not for the green sunfish.

HART: Does this conflict with Fry's concept?

*Koffler, H. 1957. Enzyme of thermal bacteria. *Bacteriol. Rev.* 21:227-240.

POIKILOTHERMIC ADAPTATIONS

PROSSER: No, I do not think it conflicts. All I am saying is that I think that Fisher's data* suggests that there are central nervous components which are involved in the swimming responses in addition to the metabolic ones. The difference between our curves and your data** is that your activity curves rise to a peak and then drop off rather gradually. The ones which Dr. Root has obtained come up to a peak as you saw, and drop off very steeply.

HART: Yes, but the active metabolism may drop off very rapidly, too.

PROSSER: Yes, I think it does. In the data which I showed you from Kanungo, the curves would come up to a maximum. The shape is somewhat different from those of Fry ^Δ. The metabolism of these goldfish was measured at different temperatures. It was not measured at the temperature of acclimation only as it was in Fry's data.

HANNON: In the data that you have just presented, I have seen a number of instances where the effects of temperature on poikilotherms and homeotherms are quite similar. For example, in many poikilotherms acclimatization to cold is accompanied by an increased metabolic rate. We see this same effect in small mammals such as the rat.

PROSSER: For a different reason, though.

*Fisher, K. C. 1959. Adaptation to temperature in fish and small mammals. *Physiological Adaptation*. pp 3-49. Ed. C. L. Prosser. Amer. Physiol. Soc., Washington.

**Fry, F. E. J. and J. S. Hart. 1949. Cruising speed of goldfish in relation to temperature. *Jour. Fish. Res. Bd. Canada*, 7:169-175.

ΔFry, F. E. J. and J. S. Hart. 1948. Relation of temperature to oxygen consumption in goldfish. *Biol. Bull.* 94:66-77.

PROSSER

HANNON: This may or may not be true; I do not feel that we have enough evidence at the present time to justify any firm conclusions either way. One basic difference between these two types of animals that should be noted, however, is the decline in the metabolic rate of the poikilotherm when he is exposed to high ambient temperatures. This is quite in contrast to the response of the homeotherm, in which exposure to high ambient temperatures has either no effect on or increases the metabolic rate.

This high temperature decline in the metabolic rate in fish and other poikilotherms is most interesting to me from the standpoint of its similarity to the effect of temperature on many enzymes. There are a great many enzymes that show increasing activities with increasing temperature until some critical point, or temperature optimum, is reached. Beyond this temperature optimum the activity declines. In many enzymes this decline at high temperatures is reversible, provided the point of protein denaturation is not reached. I would imagine that a similar reversible inactivation would also apply to the overall respiratory metabolism of poikilotherms.

PROSSER: Yes, but I do not think that the same thing is happening here. This is a result of acclimation. The direct metabolism temperature effect is what one finds in short term exposure to the heat. The acclimatory reduction in metabolism at high temperature takes days to develop, just as does the increase in metabolism in cold.

HANNON: To the best of my knowledge, instead of reducing metabolism at high temperatures, as the poikilotherms do, the mammals increase their heat loss. This I feel is a basic difference.

At the cellular and sub-cellular level, I was quite impressed by the many striking similarities between the metabolic activities of poikilotherms and homeotherms following cold-acclimatization. In fact, I do not feel there are as many incongruities here as you do. For instance, you have given a number of examples where cold acclimatization leads to an increase in the metabolic rate of the intact animal. You have also shown with whole cell preparations

POIKILOTHERMIC ADAPTATIONS

that this increase is reflected in a similar increase in the metabolic activity of several tissues such as liver and muscle. We find essentially the same results with small mammals. Then to carry such studies a step further you have also given a number of instances where cold acclimatization in the poikilotherm produces changes in enzyme activity that are the same as we find in rats. I would include among these latter effects succinic dehydrogenase, cytochrome oxidase, glucose-6-phosphate dehydrogenase, and lactic dehydrogenase as well as DPNH and TPNH cytochrome c reductase which are not affected by prolonged cold exposure in either type of animal. It is true that there are several instances where poikilotherms and homeotherms are at first glance quite different in their responses to prolonged cold exposure. This, however, may or may not be significant since even in one species cold exposure can lead to quite a variety of effects.

There are a number of factors that can influence the nature of the results obtained from in vitro tissue metabolism studies. In intact cell preparations, for example, we have the problem of quite limited exogenous substrate permeability or utilization. This is particularly true for those substrates that exist in an ionic form. But it is also true for such a common metabolite as glucose. In vitro metabolic rate of whole cell preparations, therefore, is largely dependent upon the availability of endogenous substrate, and we must be quite cautious in interpreting them.

PROSSER: That is why we used homogenation.

HANNON: Homogenates are also notoriously bad for oxidizing free glucose. They will not do it like the intact animal will.

PROSSER: We have used succinate, too.

HANNON: Practically everybody, I think, has reported an increase in succinate oxidation in the liver and muscle of cold-acclimated mammals. Skin has also shown this increase.

PROSSER: Do you find an increase in the monophosphate shunt enzymes?

PROSSER

HANNON: In our own work we have found a decrease in both liver and muscle after one month of acclimatization. Other people who have acclimatized their animals for a much longer period find no change in the system. This brings up another question: A number of investigators, including some of the workers at Dr. Hart's laboratory, Heroux in particular, have found that the liver metabolism of animals that are subjected to seasonal, outdoor acclimatization is the same in both summer and winter. Along similar lines, we have found that liver metabolism varies with the duration of exposure. It goes through a peak--in our particular circumstances at one month--and then it falls back to the normal levels. It would appear then, that the initial response to a low temperature, at least in this organ, is an increase in metabolism per unit mass of tissue. With longer exposure, however, we find an increase in the relative size of the liver. Metabolically, this increase in mass replaces the increase in unit activity, and the liver thus retains a high metabolic rate by virtue of its size. I notice in your data that practically all of the metabolic rates are expressed as oxygen consumption per gram of tissue, and there is no indication of whether the relative mass of tissue has changed. You do have evidence that the protein content does change, but I would like to ask whether there were any changes in relative liver mass comparable to those we have observed in rats.

PROSSER: Dr. Murphy has found the changes in liver size and in the same direction that you find them. That is, the liver of a goldfish that has been held at 30^o C is very small, whereas the one that has been held at 5^o C is large. We thought it has more fat on a unit weight basis. It does not. It has less fat. You are finding that the fatty acid metabolism increases, are you not?

HANNON: Yes, but we have studied only the liver. Dr. Depocas, I believe, has found that the intact animal can oxidize fatty acid at greater rates in the cold. Am I correct, Dr. Hart?

HART: Yes, but not associated with acclimation. There is a greater elevation of oxidation in the cold, but there was no change associated with acclimation.

POIKILOTHERMIC ADAPTATIONS

PROSSER: What about the Krebs cycle enzymes?

HART: No alteration.

PROSSER: How about the glycolytic ones?

HANNON: In general, we have found that the overall metabolic capacity of the Krebs cycle is increased by prolonged cold exposure. In the one month cold-exposed animal this is evidenced by an increase in the activity of all the Krebs cycle oxidases we have studied. At the enzyme level, cold exposure may or may not lead to an increased activity. Thus, in the electron transport system of the liver, it was found that the activities succinic and malic dehydrogenase and cytochrome oxidase were elevated following one month in the cold. DPNH-cytochrome reductase, on the other hand was unaffected. Similar increases in Krebs cycle activity have also been seen in muscle. On the basis of these data, we might tentatively conclude that the primary effect of cold exposure (at least after one month) is an increase in the metabolic capacity of those reactions that are rate-limiting, e.g. succinic and malic dehydrogenase and cytochrome oxidase. This conclusion, however, may have to be modified for animals that have been exposed for intervals longer than one month. Also, we have only limited data on how cold exposure affects muscle tissue, and we have no idea how changes in relative mass might affect the results that are obtained.

PROSSER: Were these Krebs cycle activity measurements calculated on a unit weight basis?

HANNON: That is correct. The increase in oxidation will probably disappear with exposures that would lead to an increase in the relative amount of tissue. In response to an earlier comment, I should mention that fatty acid oxidation, at least the oxidation of palmitic acid, does proceed at a greater rate in the liver tissue of the cold-acclimatized rat.

PROSSER: The factor of exposure time, I am sure, is very important. We have used periods of one to three weeks because this agrees with acclimation time for lethal temperatures. However, Dr. Murphy showed me some data taken from experiments

PROSSER

on muscle where both glucose and succinate were used as substrates. Her values for cold-acclimated fish seemed not to change at all. They stayed high, so that after some weeks the value in the cold was higher than the warm, hence the acclimation response was reduced activity in the warm acclimated animals with virtually no change in the cold acclimated animals. All the enzyme data that I gave you were from fish that had been on a 12 hour photoperiod.

HANNON: A number of things are variables here that we know very little about. And one of them is the variable of intermittent exposure. Other factors are the effects of changes in light as well as changes in the age or changes in the size of the animal. All of these variables, at least potentially, could lead to a big difference in the type of response you get.

HART: I would like to ask one other thing in connection with the enzyme work; since there appear to be large changes associated with the overall activity of the animal during acclimation, I wonder if enzymes associated with the maximum metabolism might be worth investigating.

PROSSER: How are you going to find these?

HART: I wonder if the cytochrome oxidase activity would have some bearing on this.

JANSKY: We could expect some differences in the cytochrome-oxidase activity and especially in the shifting of the optimum of this enzyme according to the temperature of acclimation. We have some evidence about it on insects.

HART: What would be your opinion of this approach, Dr. Jansky?

JANSKY: I would say we could find some differences in the maximum metabolism, and especially in the shifting of the temperature for maximal enzyme activity.

POIKILOTHERMIC ADAPTATIONS

PROSSER: Yes, I think the shifting of the optimum is very important, and this is one of the things that we are proposing to do soon, but I am not sure that I would agree that the cytochrome oxidase system is necessarily the limiting one for activity metabolism since these enzymes seem always present in excess. Are you implying that this is the principal route for activity as opposed to standard metabolism?

HART: I would not like to say anything about that now, since we will hear more evidence about this later on.

HANNON: I think at this time we might point out that after one month of acclimatization you do find an increase in cytochrome oxidase activity. I feel that it is important to keep in mind that practically all hydrogen transport from Krebs cycle oxidations eventually channels through this particular enzyme. Thus, it would seem likely that cytochrome oxidase may not be as much in excess as the activity measurements might suggest. In fact, it may even be rate limiting. If this proves true then cytochrome oxidase would be a very good index of maximal metabolic capacity.

PROSSER: Yes, but we found very little effect on any of the Krebs cycle enzymes that we have looked at. I do not understand the inverse acclimation of some of them. I doubted the phenomenon on the basis of Precht's experiments. However, we came up with two enzymes which show it, and it is highly significant.

IRVING: One of the things that impressed me is that when we look at the changes of the influences of temperature on various functions we expect to see some more or less continuous slopes, that is, something which will relate the rate to temperature in the form of a curve; and yet many changes of behavior occur explosively at given temperatures, whether it be the flight or the biting of the insects, or the sensation of same. Insects do not half fly. They either completely fly or they are completely quiescent. Of course, they also have certain reverse or discontinuous changes--as, for example, in the discharge of cold receptors, which apparently

PROSSER

constitute a whole area or population with different temperature thresholds. Abrupt physiological changes in temperature constitute the animal's own analysis of what the situation is because he must then expunge all other influences of everything else at those particular moments.

PROSSER: This is something we are going to explore. We hope soon to probe in the brain with electrodes and see if we can find some different recording of electrical activity at different temperatures.

EVOLUTION OF TEMPERATURE REGULATION IN BIRDS

William R. Dawson *

The possession of homeothermy by birds and mammals has exercised a major influence on their evolution, both through the biological opportunities it has afforded and through the physiological demands it has imposed. The evolution of the mechanisms responsible for this condition merits consideration not only because of its importance to these groups of vertebrates, but also because it comprises a major step in a general trend within the Animal Kingdom toward increasing control of internal state. The present discussion will deal primarily with the evolution of the mechanisms of temperature regulation in birds, although reference will be made to mammals where comparisons are appropriate. The development of temperature regulation in this latter group is treated in detail elsewhere (Johansen, 1962).

THE HISTORICAL BACKGROUND

Current concepts of the origin and early deployment of birds are largely a matter of deduction, owing to the very incomplete fossil record. The structure of the earliest known bird, Archeopteryx lithographica, from the upper Jurassic of Bavaria, places the origin of the class among the thecodont reptiles (Swinton, 1960). Birds appear to have arisen from a single line which appeared with the radiation of this reptilian order in the Triassic. The stage in the development of this line at which homeothermy was achieved is unknown, and for this reason subsequent references to the establishment of this condition in the "avian evolutionary line" are intentionally vague. Swinton (1960) suggests that the immediate antecedents of birds were arboreal and at least partially homeothermic, and that true flight was not

*Preparation of this paper was supported in part by a grant from the National Science Foundation (G-9238).

achieved until after the appearance of effective temperature regulation.

The adaptive radiation of birds, in good part made possible by the possession of homothermy, apparently began shortly after birds first appeared. However, it did not proceed at a constant rate. As far as can be determined from known fossils, the major flowering of avian evolution occurred early in the Tertiary. By the end of the Eocene most of the known orders of birds had appeared, and by the end of the Miocene, most Recent families of birds were probably in existence. Today there are over 8,000 species of living birds, representing some 28 orders and 161 families. Six orders and 39 families, not counting fossils of uncertain taxonomic position, are known to have become extinct (Storer, 1960). All contemporary birds appear highly modified for their respective adaptive niches, and none is especially primitive. Beddard (1898:160-161) concluded, "the few specially reptilian features in the organisation of birds have, so to speak been distributed with such exceeding fairness through the class that no type has any great advantage over its fellows;". In contrast, mammals include both primitive and highly advanced types. Among the former, the monotremes, though specialized in some respects, have many of the structural features of therapsid reptiles (Simpson, 1959).

BODY TEMPERATURE

Central body temperatures of active birds are generally maintained between 38°C and 43°C , with the limits for individual species being narrower (King and Farner, 1960). Perhaps utilization of this band of temperatures resulted from a compromise between two unfavorable ranges of temperature (Burton and Edholm, 1955). On one hand, it was far enough above the rather moderate temperatures which apparently prevailed in the Triassic and Jurassic (Brooks, 1949) so that physiological changes required to cope with minor fluctuations in ambient temperature would be relatively small. On the

EVOLUTION OF AVIAN TEMPERATURE REGULATION

other hand, it was sufficiently far below the lethal temperature level (about 47°C for contemporary birds) that moderate elevations of body temperature resulting from activity, for example, could be sustained without injury.

The fact that the central body temperatures of birds do fall in a fairly narrow band indicates that relatively little diversification of this physiological character has occurred in the evolution of birds subsequent to the establishment of homeothermy. One consequence of this conservatism has been to render the fundamental level of body temperature non-adaptive to climate (Scholander et al., 1950a; Irving and Krog, 1954; Scholander, 1955; and Irving, 1960), although temporary hypothermia and hyperthermia appear to have roles in short-term adjustments to cold and heat, respectively, in some species. Steen (1958) found that freshly captured small birds adjusted to winter conditions in Oslo, Norway. These included Titmice (Parus major), Green Finches (Chloris chloris), Bramblings (Fringilla montifringilla), House Sparrows (Passer domesticus), Tree Sparrows (P. montanus), and Redpolls (Acanthis flammea). They became hypothermic by as much as 9° to 10°C when exposed to cold at night. However, hypothermia did not develop in these birds when they were experimentally acclimated to -10°C . Bartholomew and Dawson (1958) regard hyperthermia as a regular feature of the response of birds to heat. The tolerance by these animals of as much as 4°C in excess of normal levels allows establishment of a favorable condition for heat transfer from body to environment when environmental temperatures rise to near the level of body temperatures maintained in cool environments. This response is of great significance in arid regions because it reduces the demands for evaporative cooling from what they would be in hot weather if body temperatures were maintained constant. The statement concerning the non-adaptiveness of body temperature of course pertains to central body temperatures and not to the temperatures of the peripheral tissues, particularly in the legs, of birds. Variation in the temperatures of these tissues comprises an important component of physical thermoregulation in these animals (Irving and Krog, 1955).

The fact that the general level of body temperature adopted by birds exceeds that of mammals may confer a slight advantage in warm environments, but its effect on heat exchange is probably inconsequential in cold ones. The difference in thermal levels for the

two classes probably reflects nothing more than differences in the temperature relations of the independent reptilian stocks from which they emanated. Variations in levels of activity and lethal body temperatures comparable in extent to the differences separating birds and mammals can be found among contemporary reptiles, desert lizards and snakes for example, (Cole, 1943; and Cowles and Bogert, 1944).

The stabilization of body temperature at a high level in birds may have demanded physiological adjustments beyond those concerned with the establishment of thermoregulatory capacities, even if the antecedents of the first homeotherms in the avian line had utilized high body temperatures for activity in the manner of many contemporary reptiles, particularly lizards. These animals, despite their utilizing body temperatures similar to those of homeotherms for activity (see Cowles and Bogert, 1944; Norris, 1953; and Fitch, 1956), apparently have not developed the capacity for prolonged existence at a high thermal level. Wilhoft (1958) found that maintenance of fence lizards (*Sceloporus occidentalis*) at their activity temperature (34° C) for approximately three months resulted in the death of some animals, increased frequency of molting in some, and increased thyroid activity in all. None of these changes was observed in the control animals, which were allowed a more normal thermal pattern in which warm body temperatures alternated with cooler ones. The duration of the daily periods spent at warm body temperatures by heliothermic lizards such as *Sceloporus* and *Uma* is apparently controlled in part by the parietal eye (Stebbins and Eakin, 1958). Elimination of this structure or shielding it from radiation significantly increased the extent to which the lizards exposed themselves to sunlight.

EVOLUTION OF THERMOREGULATORY PROCESSES

The evolution of the complex array of processes on which homeothermy depends must have involved many steps. It has been possible to gain some insight into the probable nature and sequence of

EVOLUTION OF AVIAN TEMPERATURE REGULATION

these steps in mammals by comparison of species representing primitive and more advanced levels (see Eisentraut, 1960) in development of homeothermy. This approach was employed in the classic study by Martin (1903) and has most recently been utilized by Johansen (1961). Such an approach is less useful in attempting to trace the evolution of temperature regulation in birds because of the absence in the contemporary avifauna of especially primitive forms with respect to attainment of homeothermy (see "The Historical Background"). In the subsequent discussion a good deal of dependence has been placed on information concerning the ontogeny of temperature regulation in birds and on data on the physiological responses of contemporary reptiles to temperature. Due regard has been given the difficulties of deriving evolutionary interpretations from such information: Ontogeny may only recapitulate phylogeny when expedient, and contemporary reptiles are for the most part far removed from any line of direct importance to the history of birds.

Behavior of Significance in Temperature Regulation

Significant behavioral patterns in management of temperature relations are widespread and presumably of considerable antiquity among vertebrates. The ability of fishes to select particular temperatures in experimental gradients is well known, and it appears that this type of behavior plays a role in the distribution of at least some species in nature (Sullivan, 1954). More pertinent to a consideration of the evolution of temperature regulation in birds is the ability of reptiles under favorable conditions to control their body temperatures by behavioral means (Cowles and Bogert, 1944; Bogert, 1949a, 1949b; Norris, 1953; Fitch, 1956; and Saint-Girons and Saint-Girons, 1956). Selection of suitable microclimates and absorption of solar radiation allow many species to establish characteristic and, in some cases, very high levels of body temperature when they are abroad and active. The extent of the control of body temperature which can be achieved by behavioral means when sufficient solar radiation is available is indicated by the Andean lizard (*Liolaemus multiformis*), which Pearson (1954) found could maintain a temperature above 30° C by basking, even though nearby shade temperatures were at or below freezing.

Undoubtedly the first homeotherms in the avian line received a considerable legacy of thermally significant behavioral patterns from their reptilian antecedents. Indeed, the evolution of physiological mechanisms for regulation of body temperature may well have been originally concerned with augmenting thermoregulatory behavior. As physiological capacities for temperature regulation improved, behavior came to occupy the ancillary role in the management of the heat economy evident in birds today. Many species, as a result of their migratory habits, are able to exploit various environments on a seasonal basis and to evade unfavorable conditions to a great extent. Birds resident in hot climates modify the impact of their environments to some extent by utilizing shade, minimizing activity, and, in some cases, bathing during the heat of the day (Dawson, 1954). In a few instances birds resident in cold climates also employ behavioral mechanisms in coping with winter conditions. For example, at night ptarmigan (Lagopus) utilize the shelter afforded by burrows in the snow (Irving, 1960) and Creepers (Certhia brachydactyla) huddle together in bunches of 10 to 20 (Löhr, 1955). In general it appears that birds, particularly the smaller ones, are less successful in evading the extreme conditions of their environments than their mammalian counterparts. The fact that most desert birds are diurnal and fail to take advantage of the shelter afforded by underground burrows forces them to contend with heat as well as aridity. This has an important effect on their water economies because it requires rapid rates of evaporative water loss (Bartholomew and Dawson, 1953; Bartholomew and Cade, 1956; Dawson, 1958). Such is not the case in most small desert mammals, which are fossorial and nocturnal (see Schmidt-Nielsen and Schmidt-Nielsen, 1952). The failure of birds in cold climates to utilize underground burrows and nests also deprives them of effective means of protection utilized by many mammals.

With the establishment of homeothermy in the avian line, the general thermal requirements for development became restricted to a fairly narrow range of temperatures a few degrees below the level of body temperature in adults. This restriction must have been accompanied by the evolution of elaborate patterns of parental behavior, which are evident in contemporary birds (Kendeigh, 1952).

EVOLUTION OF AVIAN TEMPERATURE REGULATION

Incubation in birds is nicely regulated so that the eggs are maintained within the appropriate temperature range most of the time, despite external conditions (compare Huggins, 1941; Irving and Krog, 1956; and Eklund and Charlton, 1958). Incubation is facilitated in many birds by the development under hormonal control of a well-vascularized and defeathered incubation patch (Bailey, 1952). The uniformity of incubation temperatures for most species indicates that little diversification of the thermal requirements for development occurred after they were originally defined.

Considerable diversity of parental behavior with respect to the post-hatching phase of development in birds is evident, and this is consistent with the wide variation in the state of maturity of the young on emerging from the egg (see "Patterns in the Ontogeny of Temperature Regulation"). The behavior of the parents nicely compensates for any thermoregulatory deficiencies in the young, so that development proceeds under essentially homeothermic conditions (Kendeigh, 1952) independent of external temperatures. The activities of the parent birds include not only protecting the young from cold by brooding, but also shielding them from solar radiation under certain conditions, as noted in pelicans (*Pelecanus erythrorhynchos* and *P. californicus*) and Herons (*Ardea herodias*) by Bartholomew et al. (1953) and Bartholomew and Dawson (1954a) and in Nighthawks (*Chordeiles minor*) by Howell (1959). As young birds attain effective temperature regulation, the role of parental behavior in their heat economy progressively declines.

Thermostatic Mechanisms

It is difficult to trace the origin of the neural mechanisms controlling temperature regulation in birds, if only because these mechanisms have thus far been characterized in only the most general terms. Regulatory activity appears to be controlled principally by thalamic or hypothalamic centers (Rogers, 1928; Rogers and Lackey, 1923), although some activity persists after these centers have been eliminated (Kayser, 1929a, 1929b). In the Domestic Fowl (*Gallus gallus*) shivering can be elicited by stimulation of cutaneous cold receptors or of central areas through reduction of skin temperature or central body temperature, respectively (Randell, 1943). Panting

appears to be controlled by a center in the midbrain, judging by von Saalfeld's observations on Rock Doves (Columba livia), and cannot be elicited by peripheral stimulation (Randall, 1943). Panting is unaffected by vagotomy in the rockdove, but is abolished by this operation in the Domestic Fowl (Hiestand and Randall, 1942).

Whatever the details of the original and present features of the mechanisms governing temperature regulation in birds, it is apparent that they must have been dependent fundamentally on a capacity for the detection of absolute temperature (as opposed to detection of temperature change). This capacity is not an original development by homeotherms, but also must be present in many poikilotherms, judging by the widespread distribution of temperature selection among them (Fry, 1958). The functional basis of absolute temperature detection is little understood, although analysis of the non-adapting fraction of the thermal sensitivity of some peripheral receptors is providing some information (Bullock, 1955). The means by which it is accomplished in the behavioral regulation of body temperature by reptiles is unknown, but recent work (DeWitt, personal communication) suggests that in the lizard (Dipsosaurus dorsalis), and presumably in other species, it is actually the temperature of the brain or one of its parts that is regulated. Rodbard (1948) claims to have demonstrated the existence of a thermally sensitive area in the hypothalamus of the turtle, which controls blood pressure, and on this basis suggests that the thermoregulatory centers of homeotherms evolved from a hypothalamic area controlling circulatory activity. Such a conclusion seems premature considering the absence of information on the neural mechanisms responsible for controlling thermoregulatory behavior and panting in reptiles.

Metabolic Level and Chemical Regulation

The basal metabolic rates of birds and mammals are as much as eightfold greater than the resting metabolic rates of reptiles of comparable size at the same body temperature (Martin, 1903; Benedict, 1932, 1938; and Dawson and Bartholomew, 1958), and the intensification of metabolism has apparently comprised a most important step in the evolution of homeothermy. Zeuthen (1953) has suggested that this intensification was achieved through prolongation of the developmental phase in which metabolism and size are nearly proportional.

EVOLUTION OF AVIAN TEMPERATURE REGULATION

Hemmingsen (1960) emphasizes that the transition from a poikilothermic to a homeothermic metabolic level was to a great extent dependent on an increase in the area of the respiratory surfaces. Obviously this transition exercised a profound effect on the respiratory, circulatory, and other organ systems of the nascent homeotherms. The bolstering of the capacity of these systems, which served to sustain heightened demands of metabolism, probably contributed subsequently to the development of the thermoregulatory processes. For example, modifications of the cardiovascular system, which allowed operation with a higher cardiac output and higher systemic blood pressure, probably improved capacities for transport of heat over those possessed by reptiles.

The elevation of the general level of metabolism made possible the development of effective chemical regulation. Such regulation appears to provide the initial means by which young birds control body temperature in moderate to cool environments. For example, the development of temperature regulation in young House Wrens (Troglodytes aedon) at an ambient temperature of 18° C is closely correlated with the appearance of muscle tremors (Odum, 1942). Similarly, in young domestic fowl, the ability to maintain body temperature at a high level during exposure to an ambient temperature of 20° C initially appears to be associated with the acquisition of the ability to shiver (Randall, 1943). These observations suggest that the development of chemical thermoregulation was one of the initial steps in the evolution of homeothermy in birds. Martin (1903) reached a similar conclusion for the evolution of this condition in mammals on the basis of his studies of temperature regulation in adult monotremes, marsupials, and placentals. If this suggestion is correct, the advent of chemical thermoregulation must have provided the initial means by which a level of body temperature established under favorable conditions as a result of suitable behavioral patterns and of an intensified level of metabolism could be maintained in cooler surroundings.

The principal development in the evolution of chemical thermoregulation in the avian line has concerned mechanisms for varying muscular heat production. Increasing muscle tonus and, ultimately, shivering are the principal means besides activity by which contemporary birds augment their heat production (Steen and Enger, 1957; King and Farmer, 1960). The ability to sustain elevated levels

of heat production for long periods of time appears well developed in many birds, particularly small northern species. These birds, which include the Snow Bunting (Plectrophenax nivalis) studied by Scholander et al. (1950b), the Yellow Bunting (Emberiza citrinella) studied by Wallgren (1954), the several previously mentioned species studied by Steen (1958), the Evening Grosbeak (Hesperiphona vespertina), and Red and White-winged Crossbills (Loxia curvirostris) and L. leucoptera) studied by Dawson and Tordoff (1959 and unpublished), have lower critical temperatures well above the ambient temperatures which they encounter in their habitats during winter. Although it would seem advantageous for these animals to be able to supplant the thermogenesis achieved by shivering with that stimulated by hormonal substances in meeting their requirements for elevated heat production, they appear not to possess the latter mechanism (Hart, 1958).

Once the intensification of metabolism had been achieved in the avian line, relatively little diversification of metabolic level appears to have occurred, other than that associated with the diversification of body size. Although the relation of basal metabolism to body weight in birds is less well known, particularly at the extremes of size, and apparently more complex than that for mammals (King and Farner, 1960), it appears similar in arctic, temperate, and tropical species. This has led Scholander, Irving, and associates to emphasize that basal metabolic rate is fundamentally non-adaptive to climate (Scholander et al., 1950a; Scholander, 1955; Irving et al., 1955, and Irving, 1960).

Physical Regulation

The various components of physical regulation, which serve to alter heat loss by modification of rates of heat transfer and evaporation, probably did not arise simultaneously in the avian evolutionary line. The ability of contemporary reptiles such as the lizards Dipsosaurus dorsalis and Sauromalus obesus to pant when heated (Cowles and Bogert, 1944; Dawson and Bartholomew, 1958; Dill, 1938) suggests that this mechanism for enhancing evaporative cooling could

EVOLUTION OF AVIAN TEMPERATURE REGULATION

have appeared in this line as a legacy from its reptilian antecedents. The early development of panting in young birds, e. g., albatrosses (Diomedea immutabilis and D. nigripes), studied by Bartholomew and Howell (1961); herons, studied by Bartholomew and Dawson, (1954a); and House Wrens, studied by Kendeigh (1939), likewise suggests that this mechanism is of considerable antiquity in birds. If panting was inherited from the reptilian antecedents of birds, its function was apparently bolstered by subsequent changes in the cardiovascular and respiratory systems, associated with the intensification of metabolism. Rates of evaporative water loss by panting lizards are a fifth or less those of panting birds of comparable size at the same body temperature (compare data on the birds Pipilo fuscus, P. aberti, and Richmondia cardinalis (Dawson, 1954, 1958) and on the lizard Dipsosaurus dorsalis (Templeton, 1960)). It would be of considerable value to an understanding of the origin of panting to determine whether or not the midbrain center controlling panting in the Rock Dove (von Saalfeld, 1936), and presumably in other birds as well, is homologous to the neural apparatus governing this activity in reptiles.

The apparently universal distribution of panting among birds contrasts to the situation in mammals, which may bring about evaporative cooling at high temperatures by panting, sweating, or behavioral means. It is probably significant that panting, though it is not a highly effective means of heat dissipation, is the only one of these mechanisms which would not interfere with flight by marring the integrity of the plumage of birds. Flight has undoubtedly created special problems for these animals because of the high level of heat production which it involves. Dissipation of this heat must require extensive evaporative cooling, owing to the effectiveness of the insulation provided by feathers. The development of the avian respiratory system was probably influenced by this need for evaporative cooling as well as by the requirements for gas exchange. Zeuthen (1942) and more recently Salt and Zeuthen (1960) have suggested that the air sacs are important in producing the necessary evaporative cooling during flight. This suggestion appears plausible, but awaits experimental evaluation.

The evolutionary history of those components of physical regulation affecting the extent of insulation in birds is obscure, but it is possible to delineate certain of the factors which must have influenced their development. Whether the evolution of feathers was originally related to heat conservation as suggested by Young (1950) or to the establishment of capacities for gliding and ultimately, flight, it is obvious that both thermal considerations and aerodynamic requirements have influenced their characteristics. The dual role of feathers appears to have imposed restrictions on the amount of variation permissible in the thickness of plumage. Irving detected no major differences between arctic and tropical birds of comparable size in the thickness of plumage (Irving et al., 1955). Subsequently he did note some minor structural differences between feathers of migratory and resident small birds in Alaska, which seemed to indicate that the latter had more effective insulation (Irving, 1960). In contrast to birds, large differences in pelage thickness between many arctic and tropical mammals are apparent (Scholander et al., 1950c).

The aspect of physical regulation dependent on vasomotor activity could have been established in the avian line prior to the development of feathers as an outgrowth of the improvement of circulatory capacity necessitated by the intensification of metabolism. However, the character of the insulation afforded by the plumage probably provided a stimulus for the development of vasomotor mechanisms to their present high level of performance in birds. Even with the inevitable wear and loss of feathers between molts, the minimum insulation afforded by the plumage is considerable, and this must make heat loss from the naked or thinly feathered portions of the body of great importance during vigorous activity or hot weather. The thinly feathered sides are exposed by holding the wings away from the body in warm environments (Bartholomew and Dawson, 1954b; Hutchinson, 1954). These areas may also serve as important sites of heat dissipation during flight. The unfeathered portions of the legs of various species appear to be important sites of heat dissipation under appropriate conditions (Bartholomew and Cade, 1957; Bartholomew and Howell, 1961). Combs and wattles of gallinaceous birds are apparently important in this respect also (see Yeates et al., 1941), although Hutchinson (1954) does not agree that this has been convincingly demonstrated thus far.

EVOLUTION OF AVIAN TEMPERATURE REGULATION

The beneficial role in the avian heat economy of vasomotor adjustments favoring extensive blood flow through thinly feathered or naked regions of the body in warm environments is reversed in the cold and in most aquatic situations. This difficulty has been met by the development of means for restricting heat loss from them. Heat loss from the lower portions of the legs is apparently minimized in many species by curtailment of the blood supply (during inactivity they can also be protected by the body feathers when the bird "sits" on them). However, counter-current arrangements for heat exchange are evident in some species, for example, wading birds such as herons, cranes, and flamingoes (Hyrtl, 1863, 1864). In either case pronounced longitudinal temperature gradients can be produced. Irving and Krog (1955) found that leg temperatures in the Gull (Larus glaucescens) ranged from 37.8°C proximally to 0°C distally when the animal was subjected to cold. Peripheral heterothermy, which is so important to the maintenance of central homeothermy, has apparently demanded the development of mechanisms of temperature compensation in the peripheral tissues which are reminiscent of those occurring in poikilothermic animals (Bullock, 1955; and Fry, 1958). The demonstration of acclimation of conduction of the metatarsal portion of the peroneal nerve to cold in the Herring Gull (Larus argentatus) provides an excellent example of this temperature compensation (Chatfield et al., 1953).

The temporal relation of the development of those components of physical regulation affecting the extent of insulation of birds to the actual appearance of homeothermy in the avian line is largely a matter of deduction. These components may have been present in incipient stages prior to the advent of this condition, but it seems reasonable that their full development occurred afterwards and was significant in conserving the increased amount of heat produced as a result of the metabolic changes discussed previously. If the fact that altricial birds (in which the events in the ontogeny of temperature regulation can readily be observed because they occur after hatching) develop fairly effective control of body temperature through chemical regulation while their insulation is still in a rudimentary state (Pembrey, 1895; Ginglinger and Kayser, 1929; Baldwin and Kendeigh, 1932; and Dawson and Evans, 1957, 1960) has any phylogenetic significance, it would appear that the development of physical

regulation has been mainly significant in reducing the energetic cost of homeothermy and in extending the range of environmental temperatures over which this condition can be maintained. Modification of this aspect of temperature regulation has, of course, subsequently comprised a major theme in the climatic adaptation of homeotherms.

It is appropriate in connection with the evolution of physical thermoregulation to mention Bergmann's and Allen's Rules, which state that forms from higher latitudes tend to be larger and to have relatively smaller appendages than their counterparts from lower latitudes. The validity and significance of these rules in climatic adaptation have recently been the subjects of some controversy (Scholander, 1955, 1956; Mayr, 1956; Newman, 1956; and Irving, 1957). King and Farner's (1960:267) comments on these rules appear useful.

Neither of the rules appears to hold generally for most species with extensive latitudinal (and hence temperature) distributions. Furthermore, the relatively slight differences in the size of the body and length of the appendages are quite trivial with respect to adjustment of heat dissipation (Hutchinson, 1954; and Scholander, 1955, 1956). This is not meant to argue for the invalidity of the "rules" in species in which such clines do clearly occur, for it is quite plausible that these clines may have developed because of the slight energy-conserving advantages conferred by these differences. It must be emphasized, however, that the magnitude of the changes in bodily dimension necessary to provide adequate adjustment of heat dissipation, or even any appreciable fraction thereof, far exceeds the genetic potential of any species.

PATTERNS IN THE ONTOGENY OF TEMPERATURE REGULATION

Considerable variation in the state of development of birds at hatching is evident, and this is reflected in difference in thermoregulatory capacities. At one extreme are the young of altricial species, e. g., passerines, which are hatched in a very immature state and do not develop effective temperature regulation until a week or more after emergence from the egg. At the other extreme are the

EVOLUTION OF AVIAN TEMPERATURE REGULATION

young of precocial species, e. g., gallinaceous birds, which are hatched at a relatively mature state and soon afterward develop such regulation. Indeed, several observations indicate that some ability for temperature regulation is present in precocial birds even before hatching. Between the extremes represented by typically altricial and precocial birds are many species, e. g., caprimulgids, which are intermediate in their developmental state at hatching.

The precocial condition is assumed to be primitive in birds (Kendeigh, 1952). Evolution of the altricial condition has been keyed to the elaboration of patterns of parental behavior. Its appearance has been considered important from the standpoint of bioenergetics. The immature state of newly hatched altricial young and the relatively short period between fertilization and hatching allows a smaller egg of lower energy content than is generally found in precocial birds of similar adult size (Huxley, 1927). Therefore less demand is made on the energy resources of altricial females per egg produced. The fact that the young do not develop beyond a very immature state in the egg is compensated for by parental activity in their care and feeding. In many species this burden is shared by both parents. Parental behavior is effective in maintaining the young at near-homeothermic levels of body temperature before their powers of temperature regulation become established. Thus they are able to develop under favorable conditions without having to expend energy beyond basic maintenance and developmental needs. In passerines, at least, the energetic obligations of homeothermy are only assumed when the young are nearing mature size (Kendeigh, 1939; and Dawson and Evans, 1957, 1960). On the other hand, precocial young, although they too may be brooded or may huddle with their siblings in cool environments (Lehmann, 1941; and Kleiber and Winchester, 1933), must rely on their own energy to a considerable degree for growth and development and for maintenance of body temperature once they are hatched (Bartholomew and Dawson, 1954a).

It has been suggested (Kendeigh, 1952; and Witschi, 1956) that the evolution of small birds was in part made possible by the development of the altricial mode of development. Certainly, the lower limit

of avian size is reached only in altricial species. The energetic considerations relating to smaller egg size and to the fact that the young are not required to assume the energetic obligations of homeothermy during a major portion of their development support this suggestion.

DISCUSSION AND SUMMARY

Any account of the evolution of homeothermy in birds will necessarily be highly speculative on the basis of the information now at hand, but it can be useful in emphasizing what appear to be the principal determinants of this evolution and in suggesting pertinent lines of future research. The transition from poikilothermy to homeothermy in the avian evolutionary line must have involved many steps, some concurrent and some sequential. With the capacities for behavioral control of body temperature which were probably present in the poikilothermic forms, this transition was probably more significant with respect to extension of the range of conditions over which body temperature could be held in the range suitable for activity than to any primary emancipation from the thermal environment. The initial steps in the establishment of physiological temperature regulation were probably metabolic, involving an overall intensification of metabolism with its far reaching demands on the structure and function of the various organ systems and then the development of chemical regulation with its underlying control mechanisms. Perhaps the rudiments of all the control mechanisms governing temperature regulation of birds were present in their poikilothermic antecedents, serving to control the behavioral and physiological components of the temperature regulation which these animals probably possessed. Extensive investigation of the neural mechanisms controlling thermoregulatory activity in birds and reptiles is needed before an evaluation of this suggestion can be undertaken.

The various components of the physical regulation in birds apparently became functional at different times. The presence of panting in various contemporary thermophilic reptiles indicates that this process is not the sole property of homeotherms and raises the possibility that it is present in birds as a legacy from their reptilian

EVOLUTION OF AVIAN TEMPERATURE REGULATION

antecedents. It appears reasonable to postulate that the mechanisms controlling the extent of insulation were developed after considerable quantities of heat became available to the nascent homeotherms with the intensification of metabolism. However, the bolstering of circulatory function required in this intensification must have provided a preadaptation for physical regulation through establishment of an efficient heat transport system. The requirements of gliding and ultimately flight undoubtedly intervened in the development of that component of physical regulation involving the plumage. Consequently the role of the plumage as insulation is at least in part a compromise between thermal considerations and aerodynamic requirements. The nature of this insulation has undoubtedly lent great importance to the perfection of circulatory mechanisms having to do with control of heat loss from the thinly feathered and naked portions of the avian body.

If the order of events in the establishment of birds was as suggested here, physiological temperature regulation must initially have been a costly process energetically. However, this would have been outweighed by the advantages which it conferred to the early homeotherm over its poikilothermic prey and competitors. Perhaps the diversification of the early homeotherms within the avian line contributed to a selection for the perfection of mechanisms of physical thermoregulation; with this diversification competition among homeotherms would have been intensified, with the most efficient types having the advantage.

Associated with the evolution of homeothermy in the avian line was the restriction of the thermal requirements for development. Satisfaction of these requirements was keyed to the development of patterns of parental behavior. It appears that the precocial mode of development is the primitive condition in birds. The evolution of the altricial mode of development has apparently been of great significance from the standpoint of bioenergetics because it requires a smaller egg of lower energy content than in precocial development, because it restricts the utilization of energy by the developing young to a minimum consistent with those maintenance processes exclusive

of temperature regulation and with the requirements of development until the young are well on their way to mature size, and because it requires elaborate patterns of parental care following the hatching of the eggs. The evolution of small size in birds appears to have been contingent upon the development of the altricial condition.

While the details of the evolution of temperature regulation in birds are obscure, they are less complex than those of mammals. Birds appear to be a monophyletic group in which there was probably but one development of homeothermy. Mammals on the other hand are almost certainly polyphyletic (Olson, 1959; Simpson, 1959), and homeothermy could have developed independently in each of several evolutionary lines as they traversed the boundary between mammal-like reptiles and mammals. The prototherians (monotremes) and the therians (marsupials and placentals), the surviving groups of mammals, appear to have been separately derived from the mammal-like reptiles (Simpson, 1959), complicating considerations of the evolution of homeothermy.

EVOLUTION OF AVIAN TEMPERATURE REGULATION

LITERATURE CITED

1. Bailey, R. E. 1952. The incubation patch of passerine birds. *Condor* 54:121-136.
2. Baldwin, S. P., and S. C. Kendeigh. 1932. Physiology of the temperature of birds. *Sci. Pub. Cleveland Mus. Hist.* 3:1-196.
3. Bartholomew, G. A., and T. J. Cade. 1956. Water consumption of house finches. *Condor* 58:406-412.
4. Bartholomew, G. A., and T. J. Cade. 1957. The body temperature of the American Kestrel, *Falco sparverius*. *Wilson Bull.* 69:149-154.
5. Bartholomew, G. A., and W. R. Dawson. 1952. Body temperature in nestling western gulls. *Condor* 54:58-60.
6. Bartholomew, G. A., and W. R. Dawson. 1953. Respiratory water loss in some birds of southwestern United States. *Physiol. Zool.* 26:162-166.
7. Bartholomew, G. A., and W. R. Dawson. 1954a. Temperature regulation in young pelicans, herons, and gulls. *Ecology* 35:466-472.
8. Bartholomew, G. A., and W. R. Dawson. 1954b. Body temperature and water requirements in the morningdove, *Zenaidura macroura marginella*. *Ecology* 35:181-187.
9. Bartholomew, G. A., and W. R. Dawson. 1958. Body temperature in California and Gambel's quail. *Auk*. 75:150-156.
10. Bartholomew, G. A., W. R. Dawson, and E. J. O'Neill. 1953. A field study of temperature regulation in young white pelicans, *Pelecanus erythrorhynchos*. *Ecology* 34:554-560.

11. Bartholomew, G. A., and T. R. Howell. 1961. Temperature regulation in Laysan and black-footed albatrosses. *Condor* 63:185-197.
12. Beddard, F. E. 1898. The structure and classification of birds. Longmans, Green and Co., London.
13. Benedict, F. G. 1932. The physiology of large reptiles. ("Carnegie Institution of Washington Publications," No. 425) Carnegie Institution of Washington, Washington, D. C.
14. Benedict, F. G. 1938. Vital energetics. ("Carnegie Institution of Washington Publications," No. 503) Carnegie Institution of Washington, Washington, D. C.
15. Bogert, C. M. 1949a. Thermoregulation in reptiles, a factor in evolution. *Evolution* 3:195-211.
16. Bogert, C. M. 1949b. Thermoregulation and ecritic body temperatures in Mexican lizards of the genus Sceloporus. *An. Inst. Biol.* 20:415-426.
17. Brooks, C. E. P. 1949. Climate through the ages. McGraw Hill Book Co., Inc., New York.
18. Bullock, T. H. 1955. Compensation for temperature in the metabolism and activity of poikilotherms. *Biol. Rev.* 30:311-342.
19. Burton, A. C., and O. G. Edholm. 1955. Man in a cold environment. Edward Arnold, Ltd., London.
20. Chatfield, P. O., C. P. Lyman, and L. Irving. 1953. Physiological adaptation to cold of peripheral nerve in the leg of the herring gull (Larus argentatus). *Am. J. Physiol.* 172:639-644.
21. Cole, L. C. 1943. Experiments on toleration of high temperatures in lizards with reference to adaptive coloration. *Ecology* 24:94-108.

EVOLUTION OF AVIAN TEMPERATURE REGULATION

22. Cowles, R. B., and C. M. Bogert. 1944. A preliminary study of the thermal requirements of desert reptiles. *Bull. Am. Mus. Nat. Hist.* 83:261-296.
23. Dawson, W. R. 1954. Temperature regulation and water requirements of the brown and Abert towhees, Pipilo fuscus and Pipilo aberti. *Univ. Calif. Publ. Zoöl.* 59:81-124.
24. Dawson, W. R. 1958. Relation of oxygen consumption and evaporative water loss to temperature in the cardinal. *Physiol. Zoöl.* 31:37-48.
25. Dawson, W. R., and G. A. Bartholomew. 1958. Metabolic and cardiac responses to temperature in the lizard Dipsosaurus dorsalis. *Physiol. Zoöl.* 31:100-111.
26. Dawson, W. R., and F. C. Evans. 1957. Relation of growth and development to temperature regulation in nestling field and chipping sparrows. *Physiol. Zoöl.* 30:315-327.
27. Dawson, W. R., and F. C. Evans. 1960. Relation of growth and development to temperature regulation in nestling vesper sparrows. *Condor* 62:329-340.
28. Dawson, W. R., and H. B. Tordoff. 1959. Relation of oxygen consumption to temperature in the evening grosbeak. *Condor* 61: 388-396.
29. Dill, D. B. 1938. *Life, heat, and altitude*. Harvard Univ. Press, Cambridge, Mass.
30. Eisentraut, M. 1960. Heat regulation in primitive mammals and in tropical species. *Bull. Mus. Comp. Zool.* 124:31-43.
31. Eklund, C. R., and F. E. Charlton. 1958. Measuring the temperatures of incubating penguin eggs. *O. N. R. Res. Rev.*, Dec., 1958. p. 1-6.

32. Fitch, H. S. 1956. Temperature responses in free-living amphibians and reptiles of northeastern Kansas. Univ. Kansas Publ. Mus. Nat. Hist. 8:417-476.
33. Fry, F. E. J. 1958. Temperature compensation. Ann. Rev. Physiol. 20:207-224.
34. Ginglinger, A., and C. Kayser. 1929. Établissement de la thermorégulation chez les homéothermes au cours du développement. Ann. physiol. et physicochem. biol. 5:710-758.
35. Hart, J. S. 1958. Metabolic alterations during chronic exposure to cold. Fed. Proc. 17:1045-1054.
36. Hemmingsen, A. M. 1960. Energy metabolism as related to body size and respiratory surfaces, and its evolution. Rep. Steno Memorial Hosp. Nord. Insulinlaboratorium 9(II):1-110.
37. Hiestand, W. A., and W. C. Randall. 1942. Influence of proprioceptive vagal afferents on panting and accessory panting movements in mammals and birds. Am. J. Physiol. 138:12-15.
38. Howell, T. R. 1959. A field study of temperature regulation in young least terns and common nighthawks. Wilson Bull. 71:19-32.
39. Huggins, R. A. 1941. Egg temperatures of wild birds under natural conditions. Ecology 22:148-157.
40. Hutchinson, J. C. D. 1954. Heat regulation in birds, p. 299-362. In J. Hammond, [ed], Progress in the physiology of farm animals. (Vol. I). Butterworths Sci. Publ., London.
41. Huxley, J. S. 1927. On the relation between egg-weight and body-weight in birds. J. Linn. Soc. 36:457-466.

EVOLUTION OF AVIAN TEMPERATURE REGULATION

42. Hyrtl, J. 1863. Neue Wundernetze und Geflechte bei Vögeln und Säugetheiren. Sitzber. Akad. Wiss. Wien. Abt. III, 48:6-7.
43. Hyrtl, J. 1864. Neue Wundernetze und Geflechte bei Vögeln und Säugetheiren. Denkschr. Akad. Wiss. Wien. 22:113-152.
44. Irving, L. 1957. The usefulness of Scholander's views on adaptive insulation of animals. *Evolution* 11:257-259.
45. Irving, L. 1960. Birds of Anaktuvak Pass, Kobuk, and Old Crow. U. S. Nat. Mus. Bull. 217, p. vii+409.
46. Irving, L., H. Krog, and M. Monson. 1955. The metabolism of some Alaskan animals in winter and summer. *Physiol. Zoöl.* 28:173-185.
47. Irving, L., and J. Krog. 1954. Body temperatures of arctic and subarctic birds and mammals. *J. Appl. Physiol.* 6:667-680.
48. Irving, L., and J. Krog. 1955. Skin temperature in the Arctic as a regulator of heat. *J. Appl. Physiol.* 7:355-364.
49. Irving, L., and J. Krog. 1956. Temperature during the development of birds in arctic nests. *Physiol. Zoöl.* 29:195-205.
50. Johansen, K. 1961. Temperature regulation in the nine-banded armadillo (*Dasypus novemcinctus mexicanus*). *Physiol. Zoöl.* 34:126-144.
51. Johansen, K. 1962. The evolution of mammalian temperature regulation. This Symposium.
52. Kayser, C. 1929a. Régulation thermique après section médullaire dorsale chez le pigeon. *Compt. soc. biol.* 100:286-288.
53. Kayser, C. 1929b. Contribution à l'étude du mécanisme nerveux de la régulation thermique. *Ann. physiol. physicochem. biol.* 15:131-223.

54. Kendeigh, S. C. 1939. The relation of metabolism to the development of temperature regulation in birds. *J. Exp. Zool.* 82:419-438.
55. Kendeigh, S. C. 1952. Parental care and its evolution in birds. *Illinois Biol. Mon.* 22:1-356.
56. King, J. R., and D. S. Farner. 1960. Energy metabolism, thermoregulation and body temperature, p. 215-288. In A. J. Marshall, [ed.], *Biology and comparative physiology of birds.* (Vol. II). Academic Press, New York.
57. Kleiber, M., and C. F. Winchester. 1933. Temperature regulation in baby chicks. *Proc. Soc. Exper. Biol. Med.* 31:158-159.
58. Lehmann, V. W. 1941. Attwater's prairie chicken, its life history and management. *North American Fauna* 57:1-63.
59. Löhrl, H. 1955. Schlafengewöhnheiten der Baumläufer (*Certhia brachydactyla*, *C. familiaris*) und andere Kleinvögel in kalten Winternächten. *Volgelwarte* 18:71-77.
60. Martin, C. J. 1903. Thermal adjustment and respiratory exchange in monotremes and marsupials--A study in the development of homeothermism. *Phil. Trans. Roy. Soc. London, ser. B.* 195:1-37.
61. Mayr, E. 1956. Geographical character gradients and climatic adaptation. *Evolution* 10:105-108.
62. Newman, M. T. 1956. Adaptation of man to cold climates. *Evolution* 10:101-105.
63. Norris, K. S. 1953. The ecology of the desert iguana *Dipsosaurus dorsalis*. *Ecology* 34:265-287.

EVOLUTION OF AVIAN TEMPERATURE REGULATION

64. Odum, E. P. 1942. Muscle tremors and the development of temperature regulation in birds. *Am. J. Physiol.* 136:618-622.
65. Olson, E. C. 1959. The evolution of mammalian characters. *Evolution* 13:344-353.
66. Pearson, O. P. 1954. Habits of the lizard, *Liolaemus multiformis multiformis*, at high altitudes in southern Peru. *Copeia*, p. 111-116.
67. Pembrey, M. S. 1895. The effect of variations in external temperature upon the output of carbonic acid and the temperature of young animals. *J. Physiol.* 18:363-379.
68. Randell, W. C. 1943. Factors influencing the temperature regulation of birds. *Am. J. Physiol.* 139:56-63.
69. Rodbard, S. 1948. Body temperature, blood pressure, and hypothalamus. *Science* 108:413-415.
70. Rogers, F. T. 1928. Studies on the brain stem. XI. The effects of artificial stimulation and of traumatism on the avian thalamus. *Am. J. Physiol.* 86:639-650.
71. Rogers, F. T., and R. W. Lackey. 1923. Studies on the brain stem VII. The respiratory exchange and heat production after destruction of the body temperature-regulating centers of the hypothalamus. *Am. J. Physiol.* 66:453-460.
72. Saafeld, E. von. 1936. Untersuchungen über das Hächeln bei Tauben. *Zeit. vergl. Physiol.* 23:727-743.
73. Saint-Girons, H., and M. C. Saint-Girons. 1956. Cycle d'activité et thermorégulation chez les reptiles (lézards et serpents). *Vie et milieu* 7:133-226.

74. Salt, G. W., and E. Zeuthen. 1960. The respiratory system, p. 363-409. In A. J. Marshall, [ed.], *Biology and comparative physiology of birds*. (Vol. I). Academic Press, New York.
75. Schmidt-Nielsen, K., and B. Schmidt-Nielsen. 1952. Water metabolism of desert mammals. *Physiol. Rev.* 32:135-166.
76. Scholander, P. F. 1955. Evolution of climatic adaptation in homeotherms. *Evolution* 9:15-26.
77. Scholander, P. F. 1956. Climatic rules. *Evolution* 10:339-340.
78. Scholander, P. F., R. Hock, V. Walters, and L. Irving. 1950a. Adaptation to cold in arctic and tropical mammals and birds in relation to body temperature, insulation, and basal metabolic rate. *Biol. Bull.* 99:259-271.
79. Scholander, P. F., R. Hock, V. Walters, F. Johnson, and L. Irving. 1950b. Heat regulation in some arctic and tropical mammals and birds. *Biol. Bull.* 99:237-258.
80. Scholander, P. F., V. Walters, R. Hock, and L. Irving. 1950c. Body insulation of some arctic and tropical mammals and birds. *Biol. Bull.* 99:225-236.
81. Simpson, G. G. 1959. Mesozoic mammals and the polyphyletic origin of mammals. *Evolution* 13:405-414.
82. Stebbins, R. C., and R. M. Eakin. 1958. The role of the "third eye" in reptilian behavior. *Am. Mus. Nov.*, no. 1870, p. 1-40.
83. Steen, J. 1958. Climatic adaptation in some small northern birds. *Ecology* 39:625-629.
84. Steen, J., and P. S. Enger. 1957. Muscular heat production in pigeons during exposure to cold. *Am. J. Physiol.* 190:157-158.

EVOLUTION OF AVIAN TEMPERATURE REGULATION

85. Storer, R. W. 1960. Adaptive radiation in birds, p. 15-55. In A. J. Marshall, ed. , Biology and comparative physiology of birds. (Vol. I). Academic Press, New York.
86. Sullivan, C. M. 1954. Temperature reception and responses in fish. J. Fish. Res. Bd. Can. 11:153-170.
87. Swinton, W. E. 1960. The origin of birds, p. 1-14. In A. J. Marshall, ed. , Biology and comparative physiology of birds. (Vol. I). Academic Press, New York.
88. Templeton, J. R. 1960. Respiration and water loss at the higher temperatures in the desert iguana, Dipsosaurus dorsalis. Physiol. Zool. 33:136-145.
89. Wallgren, H. 1954. Energy metabolism of two species of the genus Emberiza as correlated with distribution and migration. Acta zool. Fenn. 84:1-110.
90. Wilhoft, D. C. 1958. The effect of temperature on thyroid histology and survival in the lizard, Sceloporus occidentalis. Copeia, p. 265-276.
91. Witschi, E. 1956. Development of vertebrates. W. B. Saunders Co., Philadelphia.
92. Yeates, N. T. M., D. H. K. Lee, and H. J. G. Hines. 1941. Reactions of domestic fowls to hot atmospheres. Proc. Roy. Soc. Queensland 53:105-128.
93. Young, J. Z. 1950. The life of vertebrates. Oxford Univ. Press, London.
94. Zeuthen, E. 1953. Oxygen uptake as related to body size in organisms. Quart. Rev. Biol. 28:1-12.
95. Zeuthen, E. 1942. The ventilation of the respiratory tract in birds. Kgl. Danske Videnskab. Selskab Biol. Medd. 17:1-50.

EVOLUTION OF TEMPERATURE REGULATION IN MAMMALS

Kjell Johansen

The term "evolution" has a special affinity to all of us. It is an integrating symbol of what we are all concerned with. However, most of us, I am sure, are somewhat reluctant to use the word in our scientific work. One reason for this, at least among physiologists, is that our section of biology is founded solidly on measurements and carefully designed experiments, and the information acquired does not readily fall into line with the observations that have formed the theories of evolution. Fossils, unfortunately, do not render themselves easily to physiological study. I have a strong interest in the possible routes along which physiological mechanisms may have evolved. In my near awe for the term "evolution" I have found it expressive and also comforting to myself to say that I have an interest in the physiological phylogeny of certain functions. This term can be applied only to information compatible with the exactness required in a physiological study. Moreover, by using the phylum in a comparative manner, we are approaching the home grounds of evolution. As you can see from the program, Dr. Dawson and I have been ascribed the rather doubtful task of discussing the evolution of one of the profound and striking physiological characteristics of the higher vertebrates, homeothermy. Today a few mammalian forms exist which retain a number of extinct morphological characters. These animals are often called living fossils or missing links, and are mainly represented by the Australian monotremes and marsupials. For many reasons, I have decided to confine the main parts of my discussion to these orders plus the New World marsupials and Xenarthra, which also represent the archaic forms rather well, in spite of their extreme specializations. Reference will also be made briefly to other orders of mammals classified among the more primitive forms. These are the Insectivores and the Chiroptera, but there will be no time to discuss phylogenetic implications of the evolution of temperature regulation within a distinct order, like for instance, the rodents. Brief digressions will be made to exemplify how and why environmental extremes may lead to evolution of specialized physiological mechanisms also in the higher

mammalian forms. The presentation will naturally have to be fragmentary, and maybe more questions will be asked than answers given. This, I hope, will evoke a vigorous discussion in the distinguished group of specialists present. Since I have selected the term "physiological phylogeny," I will make no or only superficial reference to the important and intriguing problems related to the ontogenetic development of homeothermy in mammals.

The paleontologist supplies us with some starting points that may be useful for our discussion. Our knowledge of the origin of mammals as it has been derived from fossils has been supplemented by certain surviving mammals which, in their morphology, indicate an early divergence from the main mammalian stocks. The monotremes can, with a fair degree of assurance, be traced back to the early Jurassic period, about 150 million years ago. On this basis, many writers have jumped to the conclusion that the mammalian line became warm blooded earlier than this date, probably as a response to changing climatic conditions, or by being driven by the dominant reptilian stocks to seek life in colder or warmer regions.

The marsupials, showing striking similarities to the modern opossums, appear next in the fossil record. This indicates to us that the modern marsupials may be representative of the soft part conditions in mammals living 70 to 80 million years ago. A great many of today's marsupial features are, however, to be considered as specialized characters and not truly ancestral conditions. There are about 230 living species of marsupials, found mainly in the Austral-Asian regions, but there are also a few on the American continent. The marsupials show many similarities to placental mammals, particularly the Insectivores, which undoubtedly are the oldest stock of placental mammals.

The placental mammals arose with the Insectivores in the Cretaceous period about 100 million years ago. All present living placental mammals have probably developed from these early Insectivores. The most archaic orders are the present living Insectivores, their close relatives, the bats (Chiroptera), and a diverse group of Xenarthra. The bats, or Chiroptera, show a very close morphological resemblance to the Insectivores, except of course, the specializations associated with flight. Among the Xenarthra

EVOLUTIONARY ASPECTS IN MAMMALS

(previously also termed Edentata) the armadillos (*Dasypodidae*), have departed the least from the ancestral plan, and are a very ancient group, probably originating in the Paleocene, some 60 million years ago. Both the anteaters and the sloths of today are decidedly very specialized animals. The remaining Xenarthra have left very scanty fossil evidence. To briefly complete our palaeontological starting ground let us, via Figure 1, remind you of the remaining mammalian orders living today. Any paleontologist, and perhaps many of you, will be horrified at this unscrupulous simplicity and superficial treatment of mammalian descent. I feel, however, that this may be sufficient in our present context and prefer to return to more detailed descriptions only if they are advantageous to the physiological considerations to follow.

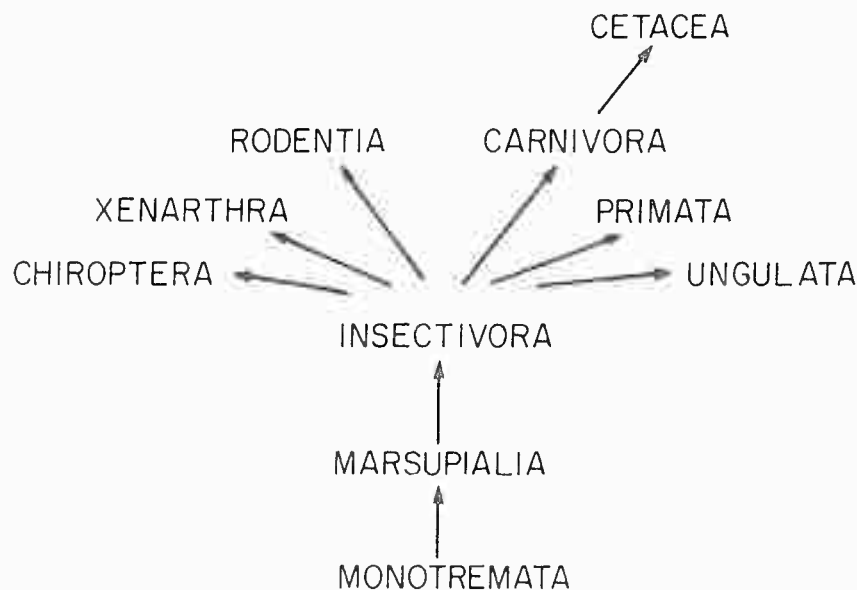

Figure 1. Schematic arrangement of the existing mammalian orders.

Turning then to the physiological phylogeny of temperature regulation, we should also list some starting points. First of all, it seems reasonable to assume that a certain variance in the environmental factors is necessary for the establishment of temperature regulation. In other words, before regulation appears there must be something to regulate against. This naturally leads us to believe that the gradual establishment of temperature regulatory mechanisms must have

started under fairly constant environmental conditions. It seems also reasonable to assume that the first homeotherms were found among the terrestrial air breathers, because of the advantage of the low conductivity of the air to heat. It is true, of course, that a great many homeothermic animals, whales and seals, for example, are today found in the sea, but they are secondarily aquatic forms with particularly developed insulation. The most stable terrestrial conditions are found and have always been found in the tropics. This justifies the assumption that the first steps toward successful homeothermy were taken in the tropics.

J. P. Darlington (1948) has advanced excellent arguments telling us that the animal dispersal both for poikilothermic and homeothermic species started in the tropics and expanded north and south. This expansion and all migratory movements of animals are generally very complex. Thus a successful species with a large distribution range extending north and south can rarely be ascribed to one or a few characteristics. It seems, however, justifiable to assume that a rapid expansion and migration southwards and northwards from the tropics must have had a bearing on a concomitant establishment of mechanisms for better regulation of internal temperature. You will see throughout this discussion, and, I am sure, in Dr. Morrison's paper as well, that the tropics today also have a great number of primitive forms. There we find the monotremes, most of the living marsupials, the overwhelming part of the Chiroptera, the Insectivores, and practically all the Xenarthra except the nine-banded armadillo.

Let us then start in the tropics and discuss the qualities known to us of the temperature regulating abilities of some of the primitive forms confined to this environment. We can realize that in order to make the transition from the reptilian to the primitive mammalian condition of temperature regulation, a rather radical change in the speed of the biological machinery had to take place, making possible a heat production high enough to keep a maintained high gradient of temperature between the core of the animal and the environment. The assessment of a higher internal temperature will in turn facilitate an accelerated nerve impulse, shortening of the latent period of a muscle contraction, and acceleration of digestion, among a number of other biochemical and biophysically linked

EVOLUTIONARY ASPECTS IN MAMMALS

processes. All these features will result in an intensification of the life processes, making possible a greater exploitation of the environment.

To keep a system at a constant temperature in a steady state situation, a change in heat loss must be balanced by a corresponding change in heat production, or vice versa. This requires a sensitive mechanism set to a particular temperature which exerts control over heat production or heat dissipation, or both. The simplest regulator we can think of in this respect would be what we are all familiar with in houses, refrigerators, etc., a regulator that turns on the heat if the temperature falls and shuts it off if the temperature rises above the set level. We can certainly appreciate the limitations of such a simple system. In order for it to work efficiently, the temperature of the object ought to be appreciably higher than that of the environment. Moreover, as the environmental temperature rises and exceeds that of the object, the whole system of regulation would fail. We shall soon see that this simplest possible system of regulation is exactly what we find in the lower mammals like the Echidna. We may ask why life did not choose the other possible way to achieve simple regulation, by regulating heat loss rather than heat production. An obvious consequence of regulation of heat loss only would be a far higher fuel cost. Securing the necessary fuel for such a regulation would require both time and range of activity that were not possible for the earliest mammals. The first records of body temperatures in monotremes were made about 75 years ago. In 1883 Macleay published records of cloacal and intra-abdominal temperatures in two specimens of *Echidna aculeata*. He found an average temperature of 28°C . Lendenfeld (1886) reported a marked increase (2°C) in the female Echidna after egg laying. Richard Semon (1894) seems to have made the first systematic study of body temperatures in monotremes on a fairly large number of specimens. The cloacal temperature he measured ranged between 26.5°C and 34.0°C and intraperitoneally from 29.0°C to 36.9°C . This represents a fluctuation of 7°C to 7.5°C at air temperatures ranging only from 18°C to 24°C . Semon points to a clear intermediate position of the monotremes between the reptiles and the higher mammals, but he does not classify them as poikilothermic, as was usual

at that time. Semon expressed the hope that the monotremes would be just as important for the study of homeothermism in mammals as they had been to the study of comparative anatomy and developmental history. If Semon lived today, he would have been very much disappointed. In spite of a few very interesting studies that followed shortly after him, practically nothing has, to my knowledge, been done in the last 30 or 40 years, when the general study of temperature regulation has flourished so greatly. Sutherland (1897) reported 29.4°C to be the average temperature of 14 specimens of Echidna. One cold morning an animal could be as low as 22°C ; whereas another one exposed to the mid-day heat registered as high as 36.6°C . This was to Sutherland an immense range for a mammal and suggested a reptilian lack of ability to regulate against temperature changes. Let me add that Sutherland did what practically all of us do who study temperature regulation. He completely curtailed the animal's ability to regulate its body temperature by natural behavior. I hope to demonstrate repeatedly the importance of this factor.

Maybe we should digress to put the importance of natural behavior in a proper relation to a phylogenetic discussion of temperature regulation. Let us then restate some of the essentials in the outstanding works of Cowles and Bogert (1944) on temperature regulation in terrestrial reptiles. The essence of their work is that terrestrial reptiles, that is, lizards and snakes, can and do keep remarkably constant body temperatures during activity. Bogert (1949) introduces some clarifying terms when he refers to the birds and mammals as largely endothermic as opposed to the reptiles, which derive their body heat mostly from external sources and can thus be termed "ectothermic." The author points in particular to the importance of the solar radiation, which may raise a reptile's temperature to levels many degrees higher than that of the air. It seems reasonable to accept the suggestion from Bogert that the acquisition and perfection of the complicated machinery for a high internal metabolic heat production has its antecedent in the ectothermic assessment of heat present today in the reptiles. The behavioral control of body temperature in reptiles implies a high degree of sensitivity to temperature changes. Sutherland's data seem to justify the conclusion that the monotremes display variable body temperatures in response to a great range of air temperatures. In 1901

EVOLUTIONARY ASPECTS IN MAMMALS

to 1903, C. J. Martin did a very outstanding study on thermal adjustment in monotremes and marsupials. The sub-title of his paper was "A Study in the Development of Homeothermism." To my knowledge, this is the only published study with this title ever made. Since Martin, in contrast to his contemporaries, also tried to record metabolism and parameters of physical heat exchange and behavior, I prefer to postpone the discussion of his main findings until after a brief review of the following work done on temperature measurements of monotremes. In 1915, Wardlaw presented a long paper entitled "The Temperature of Echidna aculeata." He reports average body temperature in the neighborhood of 30° C. Wardlaw's extensive records also contain data on seasonal as well as diurnal variations in body temperature. Morning temperatures would invariably be higher than afternoon temperatures, the difference being about 3° C. Wardlaw's data indicates a diurnal temperature change independent of the external air temperature. He also indirectly comments on the ability of the Echidna to increase rather rapidly its metabolism and body temperature during arousal from hibernation.

Burrell, in his monograph on the platypus (1927), reports that the body temperature for seven females of this species ranged between 30° C and 33° C. Wood-Jones (1923) had earlier reported an average of 32.2° C for the same species.

Martin (1903) set as his purpose locating the monotremes and marsupials on the ascending scale of superiority towards freedom from the environment. He recorded the body temperature variations at controlled air temperatures between 4° C and 40° C. His main concern was, however, to ascertain to what extent variation in heat production and variation in heat loss were used for purposes of adjustment. For comparison, he used lizards, Cyclodus gigas, cats, and rabbits besides the monotremes and marsupials. Figure 2 represents Martin's findings in regard to the relationships between body temperature and air temperature. The results were recorded under laboratory conditions where behavior as a means of adjustment was drastically reduced or impaired. The Echidnas display a variance of about 10° C between the extremes of air temperature. Ornithorynchus displays somewhat less variance and also regulates at a higher level. The marsupials studied, Dasypus maculatus, Bettongia, (the kangaroo rat) and the opossum, Trichosurus

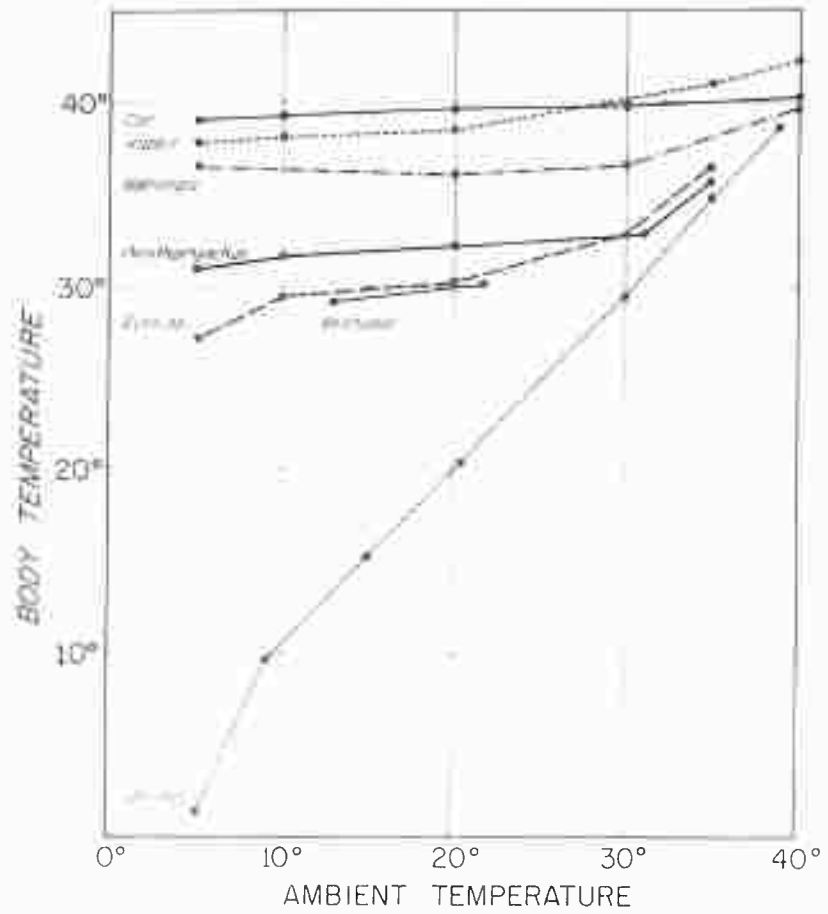

Figure 2. Relationship between body temperature and ambient temperature for the lizard (*Cyclodus* sp.) and the monotremes, marsupials, and placental mammals studied by C. J. Martin (1903). The values for *Bradypus* from Sawaya (1941).

EVOLUTIONARY ASPECTS IN MAMMALS

vulpecula, showed a variance of about 3°C --between 36.1°C and 38.6°C . His cats showed a variance of 1.4°C whereas the rabbits showed a range of 3.6°C . Martin did what very few people do but what is necessary to get intelligible results; he reported the exposure time to the various air temperatures, and also regulated air temperature both up and down while recording body temperature. His exposure times ranged between 60 and 100 minutes. Martin argues that the platypus has been unjustly listed as a poikilothermic animal. Between 5°C and 30°C air temperature, he claims that it adjusts its body temperature even better than the rabbit. However, when subjected to a temperature above 30°C , it became what Martin called "feverish." Observations done by a number of naturalists on the platypus indicate that its relation to the aquatic medium may be important for its temperature regulation. By a closer examination, it becomes apparent that body cooling is frequently attained in the tropics by returning to water (Hesse, 1937). This is particularly true among larger animals, like the water buffalo, the water buck, the rhinoceros, the elephant, and most strikingly, the hippopotamus. The elephant also frequently operates his personal, built-in shower, and his ears are of paramount importance in temperature regulation. These animals have a number of interesting specialities in their temperature regulation. However, the discussion of these I think belongs more properly in Dr. Morrison's paper. For the purpose of my discussion, it suffices to emphasize that body cooling by returning to water frequently occurs in tropical forms and also among the more primitive ones. Cooling results not only from staying submerged and benefiting from the larger conductivity of the water for heat, but also from frequent emergence from the water and obtaining a cooling effect by way of the evaporative characteristics of the air. Significantly, a great percentage of the primitive forms aid their less-developed temperature regulation by burrowing. It is interesting that the substratum temperatures in tropical Australia never exceed 85°F (Vorhies, 1945).

Martin's data on metabolic heat production shows a number of interesting features. Minimum heat production was found at about 30°C in all the species, including the higher mammals. His figures, calculated according to body surface show a similar metabolic rate for both the monotremes and the marsupials, which were only one-third of the values he got for the higher placental mammals.

JOHANSEN

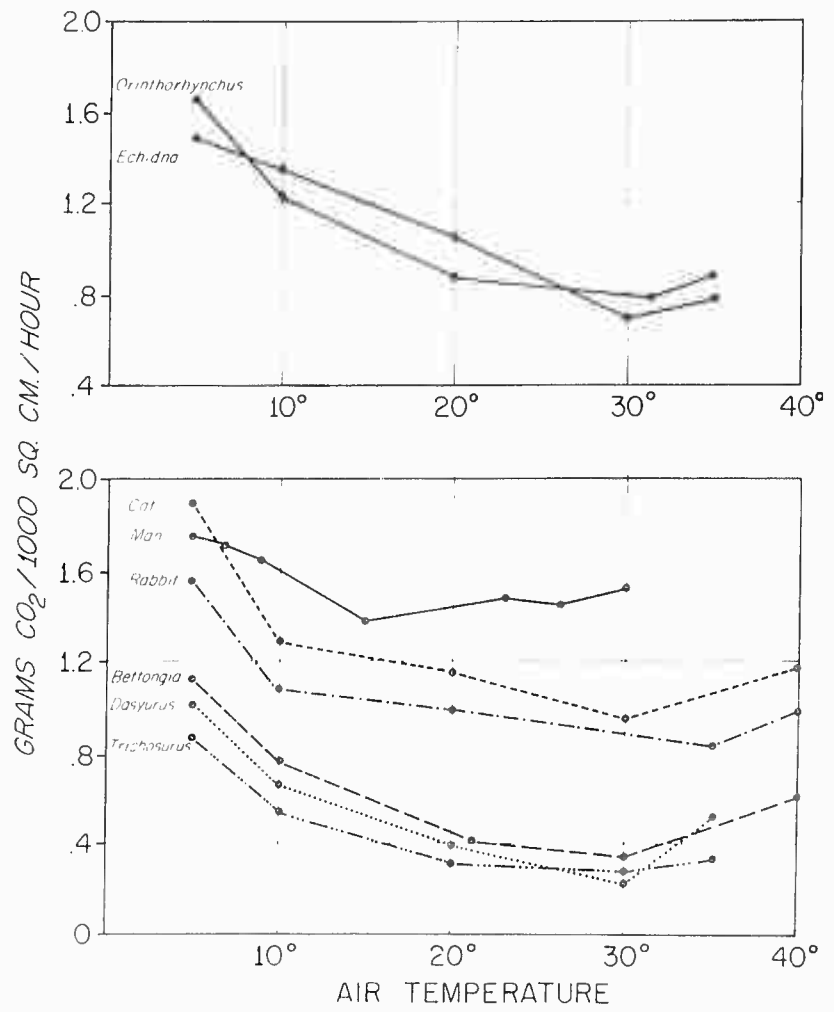

Figure 3. The metabolic values recorded by C. J. Martin (1903) in his studies on monotremes and marsupial and placental mammals.

EVOLUTIONARY ASPECTS IN MAMMALS

This low level of metabolism in these primitive forms is, of course, of the greatest interest. Martin found about 2.5 times increase in metabolism of *Echidna* at environmental temperatures of 5° C. He points out that none of the experimental animals he used maintained a constant body temperature throughout the range of air temperatures.

Of great significance to our understanding about how homeothermy has developed phylogenetically is the finding that monotremes depend only on variation in heat production and not on physical mechanisms for their maintenance of body temperature. At high air temperatures, that is about 30° C, the respiratory rates of the marsupials are affected very little by the high temperatures; whereas in the monotremes, the breathing frequencies are decidedly lower in 30° C air than in cooler air. Martin was unable to find any sweat glands in *Echidna*, and he also demonstrated that this species is devoid of vasomotor adjustments important for heat dissipation or conservation. Without any means for adjusting the core temperature by physical means, *Echidna* is vulnerable at high air temperatures and dies easily of heat apoplexia at a body temperature as low as 38° C. Under natural circumstances, I would assume that behavior mechanisms are indispensable to *Echidna*. The animal is known to bury itself several feet in the ground and only emerges after sundown on hot days. This, in turn, will drastically curtail the animal's activity time and range.

Kathleen Robinson, in 1954, studied heat tolerance in Australian monotremes and marsupials. She confirmed Martin's earlier findings about the lack of panting and vasomotor adjustment in the monotremes. She measured the evaporative heat loss and found that it is higher in platypus than *Echidna*, indicating some activity of the sweat glands in the former. These are distributed mainly on the snout, but there is also one apocrine gland opening into the follicle of each of the large hairs. The platypus shows also some adjustment in posture to facilitate heat loss. As its body temperature rises, it rolls over to its back with the under surface exposed and the legs outstretched. With higher body temperatures, the platypus becomes restless, and indicates some impairment in neuro-muscular coordination. The animals do not salivate or lick their coats during heat exposure. On the basis of the scattered data presented so far, we may be justified

in making a first attempt to characterize temperature regulation in monotremes. These animals, the most primitive among mammals available to us for experimentation, are definitely homeothermic; that is, they can regulate against environmental changes at a level higher than that of the air. This is achieved by variance in heat production and behavior. At air temperatures around and above the body temperature such regulation fails, and homeostasis is maintained by behavior. This primitive condition requires a central nervous integrating control of both behavior and heat production. Understandably these animals are confined to tropical stability and seek refuge in the stability of the substratum at the high air temperatures. The other member of the living monotremes, Ornithoryhchus (platypus), shows some advance in regulating ability over Echidna by having sweat glands.

The marsupials show a distinct advance in homeothermism, being able to vary both heat production and heat loss. I will briefly refer to some of the work done on temperature regulation in marsupials.

Sutherland (1897) observed body temperatures on sixteen different species of marsupials. The average body temperature for all the species was 36°C . Sutherland lists the wombat (Phascolomys plathyrinus) as the poorest regulator with an average temperature of 34°C . Next came the members of the genus Petaurus or the flying squirrels, with an average of 35.7°C . The koala bears (Phascogaleus cinereus) had a range of from 35.0°C to 36.5°C at air temperatures between 7.7°C and 24.5°C . Sutherland adds that upon exposure to the sun the body temperature rose rapidly, in one specimen to 38.4°C . Very interestingly, females always showed higher temperatures than males under the same conditions, and the divergence was always greatest when the females were suckling their young. The average excess temperature from 25 observations was 1.2°C . The fact that pregnant or suckling females have higher temperatures and also a more efficient regulation has often been reported, for example, Morrison (1945) for a pregnant sloth. In the larger marsupials, notably the kangaroo (Macropus giganteus) temperatures between 36°C and 37°C were recorded. Some marsupials,

EVOLUTIONARY ASPECTS IN MAMMALS

according to Krieg (1952), hibernate or have a similar torpid condition. In Marmosa cinerea, which is considered old from a phylogenetic standpoint, Eisentraut (1955) recorded an average body temperature of 34.7°C , and a range of from 29.3°C to 37.8°C , showing great dependence upon conditions of activity. I would like to give Eisentraut credit for his attempt at systematically arranging body temperatures, not as fixed numbers, but as ranges of temperatures. To indicate an animal's body temperature as a fixed point, even when giving this as an average, is not as expressive as listing the range in body temperature for the animal during normal natural conditions. Such information requires undisturbed recordings of body temperatures under all normal conditions ranging from sleep to strenuous exercise. Information of this kind is, unfortunately, available for only a very limited number of species. Such information, however, will, in my mind, express more about an animal's temperature regulating ability than do most of the parameters now in general use. Eisentraut (1956b) suggests "activity temperature" as a term for such a range. This apparently excludes conditions of sleep and rest, which ought to be included. I will, therefore, propose to call it "body temperature range at normal behavior." It is highly significant that the New World Didelphidae (Didelphis, Marmosa) have lower body temperatures than the marsupials of the Old World. The taxonomists unanimously consider the New World marsupials as the most primitive phylogenetically. Morrison, in his work on two marsupials from Central America (1956), states that the species studied, the brown opossum (Metachirus nudicaudatus) and the Eten opossum (Didelphis marsupialis), showed a homeothermism in no way inferior to that of many higher mammals. Sutherland's data (1897) show that even the very sluggish koala bear (Phascolarctos) maintained his body temperature better than any of the placental mammals. A number of authors comment on the well-developed ability of the common American opossum (Didelphis virginiana) to regulate its body temperature. As we all know, this species has migrated extensively northward, and it seems of the greatest significance that its temperature regulation is decidedly superior to that seen in the closely related tropical forms.

Robinson (1954) studied the development of the mechanisms for evaporative heat loss in Australian marsupials. She found a close correlation with structural evolutionary trends. She recorded breathing rate, pulse rate, evaporative weight loss, and she also studied sweat patterns. There is a great amount of evaporation from the respiratory tract and additional evaporation from the buccal mucosa during open-mouthed panting. Sweat glands were easily located over the entire body surface (Bolliger and Hardy, 1945). The sweat glands are, however, of a primitive apocrine type and of seemingly little importance as evaporative mechanisms. Evaporation is, on the other hand, significantly aided by salivation and coat licking. Robinson concludes that the heat tolerance in the Australian marsupials studied followed the ascending order of phylogenetic development, for instance, the primitive bandicoot (Perameles nacuta), next the opossum (Trichosurus caninus), then the cuscus (Spilocuscus nudicaudatus), the koala (Phascolarctos cinereus), the wallaby (Petrogale penicillata), and most superior, the wallaroo (Macropus robustus).

Higginbotham and Koan, in 1955, studied temperature regulation at elevated air temperatures in the Virginia opossum (Didelphis virginiana). They found that when body temperature increased to about 38° C, panting, profuse salivation, and licking of saliva upon feet and tail and parts of the trunk, was common. They monitored anaesthesia to a point where panting and salivation still persisted, but coat licking, of course, was abolished. This fact prevented the animal from keeping the body temperature at sub-lethal levels, and they conclude that the spreading of saliva upon the body surfaces and subsequent evaporation constitutes an indispensable mechanism for heat dissipation. Robinson and Morrison (1957) studied the reactions to hot atmospheres of various species of Australian marsupials and placental mammals. Their material covers as many as 25 species of Australian marsupials, plus 4 indigenous Australian rodents. They make the very interesting and, in my mind, important comparisons of temperature response to activity in some of their subjects. In members of the Dasyuridae, rises of 4° C were not uncommon. They report that maintenance of body temperature at a constant but higher than normal value was successfully achieved by all their animals at air temperatures of 35° C. At 40° C air temperatures, some species failed to adjust to a steady state condition.

EVOLUTIONARY ASPECTS IN MAMMALS

However, all their species of Phalangeridae achieved thermal equilibrium at an air temperature of 40°C . The carnivorous marsupials seemed to be particularly vulnerable at the 40°C air temperature. Most of the species showed increased respiratory rates at the high air temperatures. Also open-mouth panting, and salivation and coat licking in typical postures promoting heat dissipation frequently appeared. The Tasmanian devil (Sarcophilus harrisii), was an exception and showed no reaction other than an increase in water consumption. The authors point to the fact that the species unable to maintain equilibrium at 40°C were all among the most phylogenetically primitive. The author's attempt to classify the ability among mammals to dissipate heat is shown in Tables I and II, which are taken from their work.

Bartholomew (1956) has presented perhaps the only detailed study of the various facets of temperature regulation in a marsupial. He made careful studies of the macropod (Setonix brachyurus) both under laboratory conditions and in the field. He recorded a considerable diurnal lability in body temperature related to the daily cycle of activity in the field. The species studied showed a typical nocturnal activity pattern, and the day-time rectal temperatures of 37°C were significantly lower than the night-time temperatures. It is important that the slight excitement occurring during attachment of thermocouples could cause temporary elevations of body temperature up to 1.5°C in the rectal temperature. Upon the exposure to high air temperatures (40°C), a copious secretion of saliva and licking of the feet and tail, and a distinct vasodilation of peripheral parts seem responsible for maintenance of thermal balance at these high air temperatures. The increase in respiratory rate was appreciable, up to 200 per minute, but never as vigorous as, for instance, panting in a dog. When the animals were returned to room temperatures of 20°C there were indications that the peripheral vasodilation persisted for some time after removal of the heat stress. The elevation of the deep-body temperature during the heat load seemed moderate and did not exceed 1°C . At extreme heat stress with dry bulb temperatures of 44°C for 4 hours or more, the animals showed no apparent failure to maintain the thermal equilibrium (Fig. 4). Temperatures of peripheral parts like the feet and tail, rose rapidly to levels almost

JOHANSEN

Group	Thermal Equilibrium			
	None	$\Delta T > 2^{\circ} C$	$2^{\circ} C > \Delta T > 1^{\circ} C$	$\Delta T < 1^{\circ} C$
Monotremata	Echidna Platypus			
Dasyuridae	Mars. Mice Mars. Rat	Nat. Cat		Tas. Devil
Peramelidae	Bilby	Bandicoot		
Phalangeridae			Gliders Possums Cuscus	
Phascokarctidae			Koala	
Macropodidae			Rat. Kanga. Pademelon Wallabies	Walleroo Kangaroos
Rodentia	Giant naked -tail rat Water rat Rabbit	Naked-tail rat White mouse White rat		Field rat
Chiroptera		Fruit bat		
Carnivora		Cat		Dog
Artiodactyla	Pig		Cow	Sheep
Primates				Monkey Man

Table 1. Comparison of the heat regulatory ability of mammals at 40° C.
From Robinson and Morrison, 1957

EVOLUTIONARY ASPECTS IN MAMMALS

Normal Rate	Modification at 40° C	
	Slight	Marked
Slow (20-30/min)	Echidna Platypus Bilby Man	Bandicoot
Moderate (60-120/min)	Tas. Devil Cuscus Water rat White rat Monkey	Gliders Possums Koala Wallabies Wallaroo Kangaroos Rabbit Fruit bat Cat Dog Pig Sheep Cow
Fast (>150/min)	Sugar glider White mouse Naked-tail rat Field rat Mars. rat	Mars. mice Mars. Nat. ca

Table II. Comparison of respiratory response in mammals at 40° C. From Robinson and Morrison, 1957.

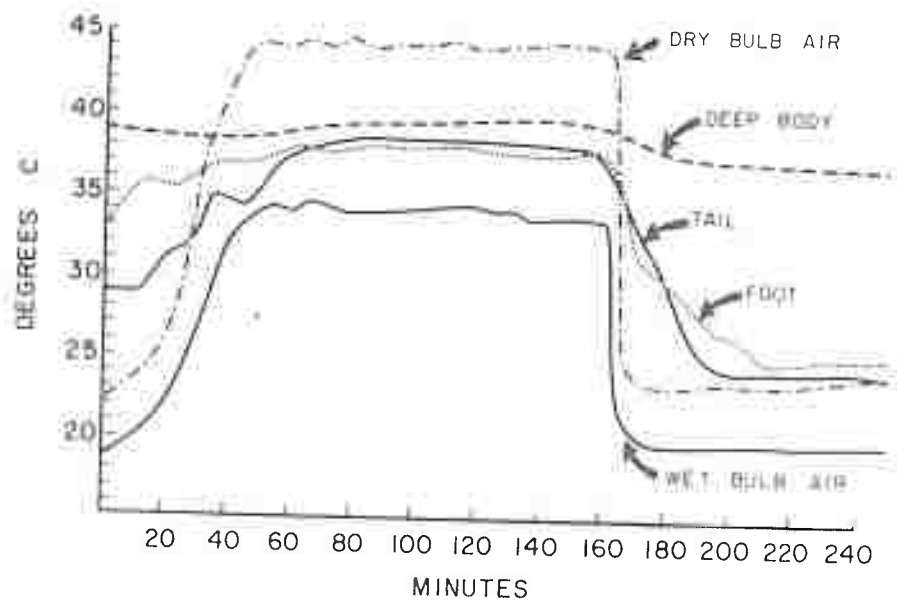

Figure 4. The effects of a dry bulb air temperature of 44°C on the body temperature of an adult *Setonix* sp. (G. A. Bartholomew, 1956).

EVOLUTIONARY ASPECTS IN MAMMALS

within the range of the deep body temperature. The foot and tail were, however, held at levels below the core and the environment by conspicuous secretion and licking with saliva. Again, upon a sudden change to 20°C air temperatures, the maximally involved heat loss mechanisms showed some delay in adjusting to the new conditions, and body temperatures fell rapidly 2°C to $2\frac{1}{2}^{\circ}\text{C}$. The licking and salivation seemed, however, to stop immediately upon cessation of the heat stress. At moderately low air temperatures (3°C) two animals averaged slightly lower body temperatures than normal for quiet animals at room temperature, whereas, one animal over-compensated and showed a body temperature above resting levels for most of the time. All animals shivered violently during the cold exposure. Again I think it is highly important that the body temperatures of the animals rose rapidly after removal from the cold (Fig. 5), indicating again some persistence of the compensatory mechanisms, this time violent shivering after the actual cessation of the cold stress. Bartholomew tried to evaluate the peripheral vascular situation by temperature measurements. His data, as in Figure 6, shows very conspicuous gradients, in particular along the tail. Bartholomew interprets the gradients in proportion to the degree of local vasoconstriction. It seems, however, conceivable that a counter-current effect, which in other animals is responsible for tremendous temperature gradients in peripheral extremities, might be in operation and thus conserve heat. Again, Bartholomew noted that there is a gradual diminution in peripheral vasoconstriction following exposure to cold. In my own interpretations of his data these repeated findings of delays in the transitions between regulatory states indicate some slowness in the integrative apparatus controlling the effector responses in temperature regulation. I will try to elaborate this assumption in more detail when discussing my own data on the armadillo. Bartholomew also exposed some wallabies to -10°C for two hours. Such temperatures are never encountered by this species in its normal habitat. At this time, both the subjects studied over-compensated to the cold stress, and showed a deep body temperature more than 1°C above the normal resting level. The feet and tail showed a marked vasoconstriction, and the peripheral temperature approached 0°C . Of great interest, the foot, and to a lesser degree the tail, showed waves of vasodilation very similar to cold vasodilation. Bartholomew's data indicate clearly that the ability to

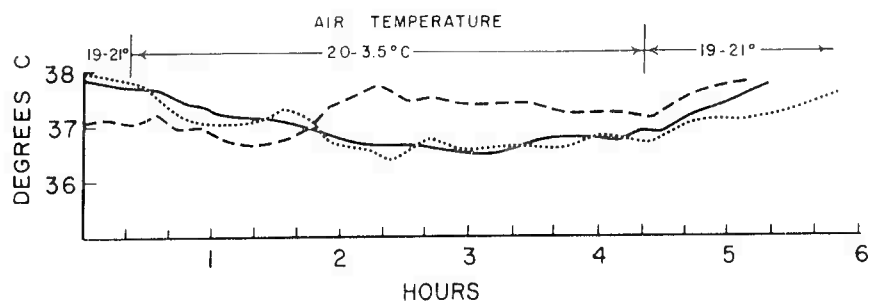

Figure 5. The response of deepbody temperatures of three specimens of *Setonix* sp. subjected to prolonged exposure to air temperatures as low as they ever encounter under natural conditions. (G. A. Bartholomew, 1956).

EVOLUTIONARY ASPECTS IN MAMMALS

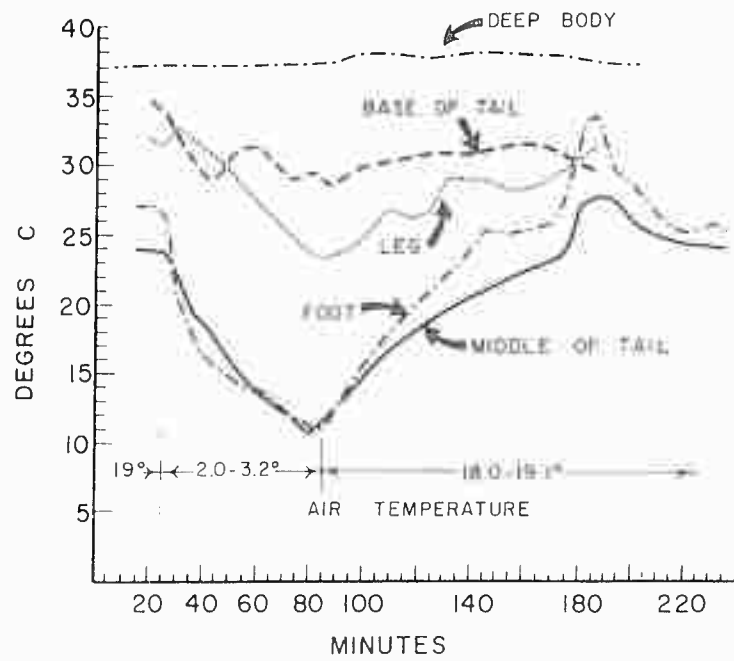

Figure 6. The deep body and skin temperatures of an adult *Setonix* sp. during exposure to low air temperatures. (G. A. Bartholomew, 1956).

JOHANSEN

regulate deep body temperature in the marsupial (*Setonix* sp.) is equally as efficient as that displayed by many placental mammals of similar size. The ability to regulate even extends to air temperatures below and above those ever encountered in the animal's natural habitat. Under severe positive heat loads, both sweating and panting was decidedly less important than copious salivation and licking. This seems to be a general specialization within the marsupial order; it has been demonstrated by Robinson and Morrison (1957), and others. Bartholomew points out that this very effective mechanism for facilitating heat loss is a specialized

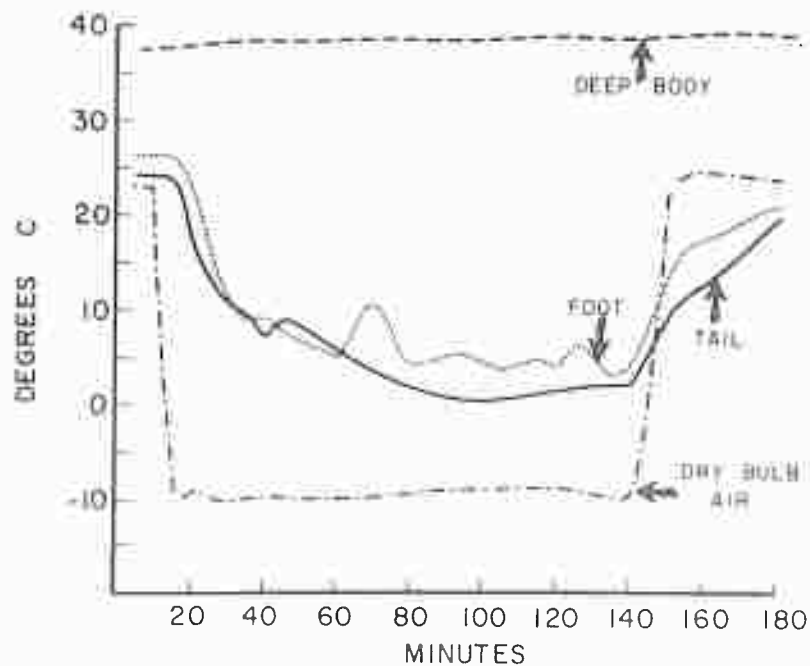

Figure 7. The response in body temperature of an adult *Setonix* sp. to an air temperature much lower than that which ever normally occurs in its environment.

EVOLUTIONARY ASPECTS IN MAMMALS

behavioral response, in contrast to the pure physiological mechanisms of sweating, panting, and vasodilation. This specialization limits the usefulness of the method since it can only operate effectively in an animal resting, and would be less useful to a rapidly moving animal. To briefly summarize the temperature regulating ability of the marsupials living today is very difficult, if not impossible. The group is exceedingly diversified, and having been practically indigenous to Australia with little competition for a very long time, marsupial life has adjusted to most habitats available. With the very interesting exception of the Virginia opossum of North America, the marsupials are confined to the tropical or neotropical regions. This, however, may not be related so much to inferiority to placental mammals in temperature regulation as to their very specialized mode of reproduction. In this regard, Bartholomew presents very interesting and important data on the ontogenetic development of temperature regulation in the marsupial, *Setonix* sp. I consider this a topic in itself, however, and can find no time to discuss it now. The marsupials so far studied in regard to temperature regulation indicate clearly a lower level of resting body temperature in the more primitive forms like the Dasyuridae which show values down to 33°C to 34°C at resting conditions, at 20°C air temperature; whereas the specialized, phylogenetically more advanced species show a higher resting level and a smaller range of variation. As more information becomes available, like the important works on Australian marsupials by Robinson and Morrison (1957) and Bartholomew (1956), this unique indigenous fauna may enable us to talk with more confidence about the role of the phylogenetic position vis a vis the influence of environmental factors for the establishment of homeothermy. Common to temperature regulation in all marsupials is the presence of physiological effector mechanisms of both chemical and physical temperature regulation. Some of them, like sweating and panting, seem generally to be of rather limited importance, being substituted by specialized behavioral responses like the coat licking. In my own interpretation of Bartholomew's important work on *Setonix*, it seems of the greatest significance that the integrative control of the otherwise well-developed effector mechanisms show some lag in precision, compared to higher placental mammals. It is conceivable that even more striking differences in this

respect are demonstrable in the more primitive marsupials not yet subjected to such a detailed examination.

Turning next to the placental mammals, we are, of course, confronted with an even greater complexity in phylogenetic development and diversity in ecology than for the marsupials. The limitation deemed necessary in this treatment may reflect a personal bias, and I do hope the subsequent discussion will give room for your feelings about these problems.

A starting point for the phylogenetic discussion of temperature regulation among the placental mammals has to be the Insectivores. The tenrec of Madagascar (Centetes ecaudatus) is probably the most phylogenetically primitive of all the placental mammals living today. Eisentraut (1955, 1956b), who together with Rand (1925), seems to be the only worker having experimented with temperature regulation in this important species, states that the animal estivates during the dry season, which corresponds to the winter season. The tenrec shows in general an extraordinary labile body temperature, fluctuating between 24.1°C and 34.8°C . The tenrec is a typical nocturnal animal and shows a diurnal cycle of more than 10°C when the air temperature changes only 3°C to 4°C . The body temperature must thus be closely related to the activity of the animal. Eisentraut notes that the animal is able to perform normal coordinated activity at body temperatures down to 25°C . It is unfortunate that no detailed study measuring other parameters than body temperatures has yet been done on this very interesting species. Rand comments briefly that two other species of tenrecs (Hemicentetes semispinosus and Setifer setosus) remain active all year around.

Eisentraut (1956b) also reports body temperatures in two other species of primitive Insectivores (Hemiechinus auratus and Parachinus aethiopicus). They show a range in body temperature of 33.4°C to 36.4°C and 31.2°C to 36.2°C respectively. We may briefly comment on the extensive studies of the European hedgehog, particularly referring to its hibernating ability. Most authors report a rather large lability in the body temperature of this species, from 31.2°C to 36.5°C . Morrison (1957) has argued that this great range in all probability results from measurements taken in the

EVOLUTIONARY ASPECTS IN MAMMALS

hibernating season when the animal is in a transitory state. When only body temperatures from representative times of activity are taken, Herter (1934) reports a range of 2°C , and reports a difference in activity temperature between summer and winter of about 1°C for the hedgehog. The one specimen of Erinaceus europeus subjected to measurements by Morrison (1957), shows the range of 34.8°C to 36.4°C with an average of 35.6°C . Although it has been decided that we leave out any detailed discussion of hibernation in this symposium, it seems justifiable to comment on Eisentraut's statement (1956a) that hibernators generally show imperfect heat regulation also during the active season; and he includes all known hibernators in the group of lower warm-blooded animals. I am, myself, and I know many others are, willing to challenge this statement. "Hibernation," although used to express the seasonal and diurnal condition of sleep displayed by a variety of the smaller mammals is really not representative as a term for all these species, and a great number of the true hibernators can, in my mind, be classified as extremely specialized and very far from primitive in their mode of temperature regulation.

The shrews represent an interesting and successful group of Insectivores. In spite of their small size, which is obviously disadvantageous in the cold, they have left behind most fellow Insectivores and invaded the north temperate and even arctic regions. They are, for instance, found here around Fairbanks and in Norway even farther north. Apparently, no detailed studies have been made of these extreme northern populations of shrews. Morrison, Ryser, and Dawe (1959) have, however, presented a careful study of the shrew (Sorex cinereus) obtained from the Wisconsin region. The authors noted that the manipulation and handling of the animals during measurements of their body temperatures invariably increased the body temperature. The increase occurs very rapidly, often 1°C per minute, and the body temperature could attain a level above 41°C . Similar elevation in body temperature became apparent after exercise. The body temperature seems always to level off at about 41°C . Figure 8 shows the results. More than anything it demonstrates a great variability of body temperature; this animal is unquestionably one of the more successful small animals living today. Its labile body temperature can hardly be classified as a

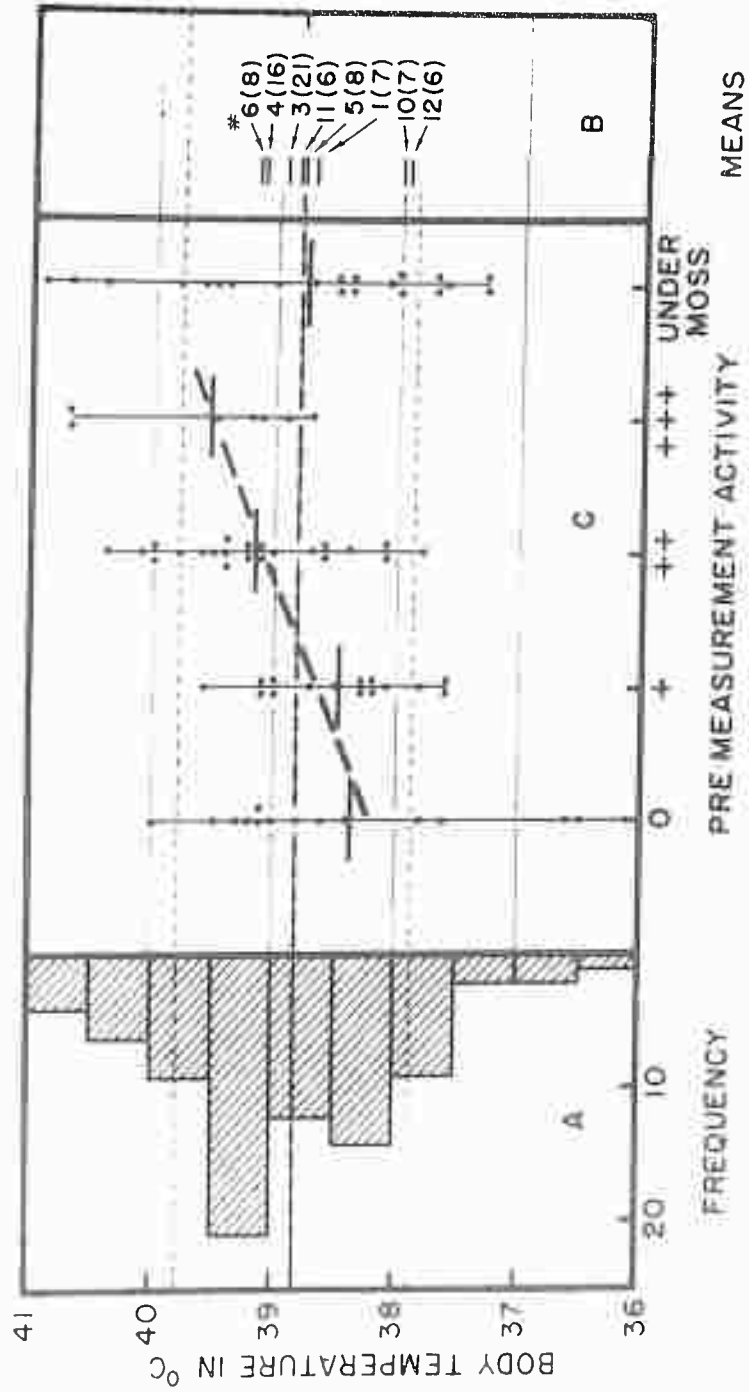

Figure 8. Body temperature of shrews. A, frequency-distribution bar graph for eighty-one values; B, mean body temperature in individuals; C, effect of normal activity on body temperature; points are individual measurements; horizontal bars show average value at each activity level; 0 = sleep or motionless; + = moving in place; ++ = moving around; +++ = feeding or running, vigorous movement. (Morrison, Ryser, and Dawe, 1959).

EVOLUTIONARY ASPECTS IN MAMMALS

primitive characteristic. It seems obvious to me that an animal this size together with a number of other smaller ones, like for instance the birch mouse (weighing 7 to 12 grams) I have studied (Johansen and Krog, 1959), and the little pocket mouse (Perognathus longimembris) studied by Bartholomew and Cade (1957), have to allow for a greater variability in the body temperatures to regulate at all. We can appreciate the enormous activity needed by these animals to secure enough fuel for their high-paced metabolic machinery. The labile body temperature is thus in a number of species expressive of a specialization rather than a primitive character. It should prove most interesting to study temperature regulation in shrews of the northern-most habitats.

The exceedingly specialized bats, the Chiroptera, offer a number of interesting features in mammalian phylogeny. They are mostly confined to the tropics, although some small Micro-Chiroptera, Vespertilionidae, approach the arctic regions on the Scandinavian Peninsula and in Alaska. It seems to the benefit of all of us, however, that I leave the discussion of this important order to a far greater specialist than myself, Dr. Morrison, who has done extensive research on a number of species both among the Micro- and Mega-Chiroptera (Morrison, 1959). Before I leave the important Insectivores, let me remind you that they are generally small in size, mostly confined to the tropical and temperate regions. They display a rather great lability in body temperature, and many of them are hibernators. A substantial number of species are typical substratum dwellers, with burrowing habits. Some are excellent nest builders. Their body temperatures tend to show a large range and lability, but are regulated at a higher level than those of most marsupials.

Let us next turn to the phylogenetically very interesting group, Xenarthra. They consist of the armadillos, the Dasypodidae, the anteaters, the Myrmecophagidae, the sloths, the Bradypodidae, and the Old World scaly anteaters, the Manidae. The extremely interesting and phylogenetically important Orycteropus called the aardvark, or Cape Anteater, is a zoologically very isolated form. This animal retains a number of characteristics present in the earliest eutherians. Some authors, like H. Winge (1941) place it

JOHANSEN

together with the edentates (*Xenarthra*), others with the insectivores, and still others at the base of the ungulate stock. Unfortunately for us, nothing has been done yet with this unique representative of the primitive placental mammals.

Representatives of the Old World's scaly anteaters have likewise scarcely been subjected to study in regard to their temperature regulating ability. Eisentraut (1956b) reports a body temperature range for *Manis tricuspis* from 32.2° C to 35.2° C. A similarly limited number of observations is available on the tropical anteaters from Central America. Wislocki and Enders (1935) report that the giant anteater (*Myrmecophaga jubata*) shows a rectal temperature between 32° C and 34° C at air temperatures between 16° C and 21° C. The three-toed anteater (*Tamandua tetradactyla*) shows rectal temperatures between 33.7° C and 34.6° C at air temperatures between 25° C and 27.6° C. The more sluggish two-toed anteater (*Cyclopes didactylus*) displayed a lower level of body temperature between 28.9° C and 31.3° C and showed a greater variance during exercise than the other two species. Enders and Davis (1936) recorded somewhat higher rectal temperatures on the *Tamandua tetradactylum*. They got 35.0° C to 35.7° C at an air temperature of 27° C. The uniquely specialized group of sloths has been studied by a number of workers. In 1924 Ozorio de Almeida and Branca de A. Fialho observed a range from 30° C to 32.9° C at an air temperature between 19° C and 25.8° C for the three-toed sloth (*Bradypus griseus*). Kredel (1928) recorded a range from 27.7° C to 36.8° C at air temperatures from 24.5° C to 32.4° C. Upon exposure to a moderate cold stress, the three-toed sloth loses considerable heat rapidly. According to Gibbs, cited by Wislocki (1933), *Bradypus griseus* lost 8° C in deep rectal temperature, dropping from 33° C to 25° C in 2 hours and 40 minutes when transferred from an air temperature of 26° C to 13° C. Britton and Atkinson (1938) often observed spontaneous variations in body temperature of *Bradypus* with no apparent reason. In the light of this it seems of interest that Irving et al. (1942) found that the resting metabolism could be readily depressed, particularly in relation to disturbances of the breathing pattern. The two-toed sloth (*Choloepus hoffmanni*) is more active than *Bradypus* and

EVOLUTIONARY ASPECTS IN MAMMALS

shows also a higher average body temperature. At air temperatures of 28°C to 23°C , Bradypus showed an average of 33°C , whereas Choloepus showed 34.4°C . The difference in intramuscular temperatures was even greater with values of 34.6°C for Choloepus and 32.4°C for Bradypus. Bradypus occurs only in the lower neo-tropical altitudes and is particularly prevalent in regions with small fluctuations in air temperature and dense vegetation providing ample shade. Choloepus has a similar habitat but is also able to withstand colder areas with occasional freezing in altitudes up to 7,000 or 8,000 feet (Britton, 1941). Choloepus has not yet been studied in regard to temperature regulation in these colder areas; this project, however, seems to promise a great deal. The body temperatures of Bradypus drop precipitously when exposed to 10°C air temperature and reached 20°C after about 5 hours. Below this temperature, a lethargic condition seemed to ensue. Cold was apparently a strong stimulus to muscular activity. Marked hypertonus was noticeable, but no shivering was visible at any temperature. This is of particular interest in light of the extremely low mass of skeletal muscle in the sloth. Britton and Atkinson (1938) report that the skeletal muscle mass in Bradypus is only 25% of the body weight. The corresponding figure for the higher mammals ranges between 45% and 55%. Upon exposure to sun, the rectal temperature rose 2°C to 4°C within 30 minutes, and the animals struggled vigorously to get free. Getting freedom, they promptly sought shade under the nearest tree. Irving et al. (1942), in their interesting study on respiration in the sloth, mentioned an oxygen consumption about half of what is generally found in higher mammals, with values approaching what Martin found for the monotremes and some marsupials. Comparing the two sloths, the three-toed is far inferior in its ability to maintain a fairly uniform level of body temperature and is helplessly unable to venture into an environment outside the tropical stability. The unsurpassed slowness is interesting in the light of the small muscle mass. The low resting metabolism is shared with the other members of the Xenarthra and the monotremes and many of the marsupials. We have throughout this discussion seen that very early mammals became able to increase their metabolism by shivering, thus compensating for an increased heat loss. This mechanism appeared before the ability to regulate heat loss intrinsically. In the sloth things are seemingly different. The animal almost

entirely lacks the potential to shiver. The three-toed sloth seems in his unique laziness to depend upon his exceptionally high insulation--nearly as great as that of many arctic animals. The result is an extremely labile body temperature which at low air temperatures shows greater fluctuations than encountered even in the monotremes. The three-toed sloth seems to be the least fitted of all mammals to withstand decreased air temperatures, a fact which I think illustrates the importance of metabolic compensation for maintenance of thermal balance. The other members of the Xenarthra show a far more advanced temperature regulation. The armadillos are very versatile animals with large distribution areas, as explicit in their temperature-regulating capacity. More or less casual observations of body temperature of armadillos were made and reported by de Almeida and de A. Fialho (1924). Eisentraut (1932) recorded an average body temperature in *Tolypeutes conurus* of 32°C in a tropical habitat. Wislocki (1933), studying the nine-banded armadillo in Panama, reported 34.5°C as an average body temperature at air temperatures around 25°C . I have recently done a study on temperature regulation in this same species and will submit some of these data in a little more detail.

The material studied came from Texas and not from tropical Central America where most of the earlier observations on this species have been made. I mentioned earlier that the dispersion of animal life north and south from the tropics is a factor presumably of great importance in the evolvement of more refined homeothermic adjustments. It struck me that the nine-banded armadillo is one of very few animals that in our time has taken steps to leave the tropical stability. The distribution area for the nine-banded armadillo is today very large. It ranges south into Northern Argentina, spreads over all of the countries east of the Andes, reaches the Pacific Coast in Ecuador, and extends throughout Central America and most of Mexico. About a hundred years ago, the animal crossed the border into the United States and is now well established in most of Texas, the southern part of Arkansas and Oklahoma, most of Louisiana, and southwestern Mississippi. Furthermore, it is established in Alabama and Florida. In Florida, the armadillo is reported to have increased its range by about 50% from 1954 to 1958. There are also persistent reports that there are

EVOLUTIONARY ASPECTS IN MAMMALS

armadillos in Kansas, spreading rapidly northward. At present the animal is still spreading north and east in the United States. According to Talmage and Buchanan (1954), the migration of the armadillo is one of the most amazing in the animal kingdom, comparable almost to the lemming migrations. From the distribution area it is apparent that the armadillo faces very diversified ecological situations and that its success must at least partly be dependent upon an extraordinary ecological potential, while the other members of the order, the sloths and anteaters, are still confined to their tropical habitat. The entire range of the armadillo is characterized by having neither extreme cold nor extended periods of cold weather. The northern parts of the area, however, occasionally show quite low temperatures for short periods and have a typical seasonal and diurnal periodicity. This unique dispersion rate, bringing the animal out of the tropical stability and into the periodicity of seasons and larger diurnal variations, plus its phylogenetic position, suggested to me that some valuable information in regard to the phylogenetic development of homeothermy could be expected.

The diurnal cycle of deep rectal temperature under controlled conditions is presented in Figure 9. At a constant air temperature of 25°C , the diurnal cycle ranges between 34.0°C and 36.4°C . The animals were free to build nests from dry hay and were confined in a room of considerable size allowing for exercise. The diurnal cycle is obviously related to their nocturnal activity pattern. Following forced exercise, the deep body temperature may increase to 37°C or 38°C . At 30°C ambient temperature the animals were usually very sedate, no signs of discomfort, and rectal and skin temperatures were nearly constant, the difference between the two being surprisingly small. A rectal temperature of 34.5°C could correspond to a skin temperature on the soft belly as high as 34.2°C and on the armor 33.9°C . Under these conditions the gradient is less than 1°C between the core and the shell. The oxygen uptake showed only small variations and ranged from 200 cc to 275 cc of oxygen per kilo animal per hour. Figures 10 and 11 demonstrate these points; a slight lowering of the air temperature brought about a dramatic response. The most conspicuous feature was a sudden increase in rectal temperature. Thus, if the air temperature was decreased from 30°C to 25°C , the deep rectal temperature might

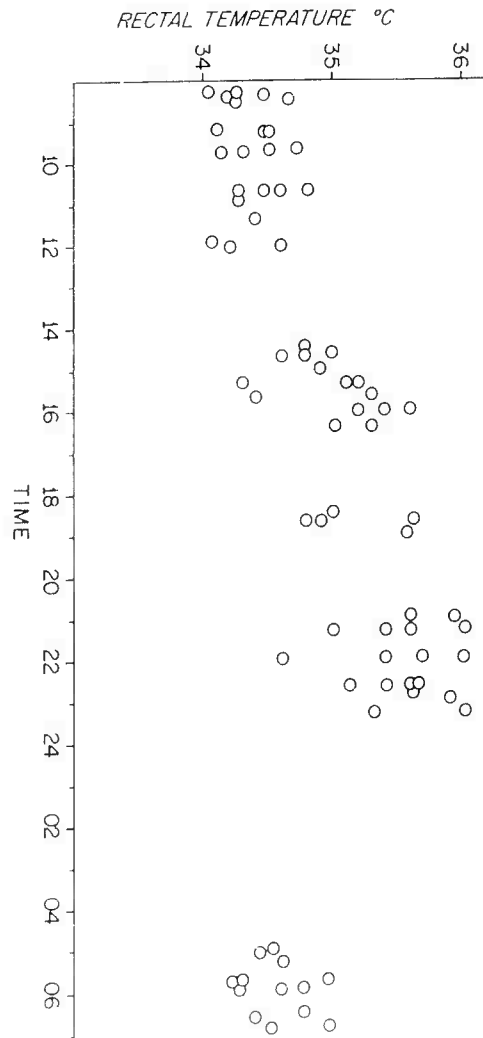

Figure 9. Diurnal cycle of deep rectal temperature in the armadillo. (Johansen, 1961).

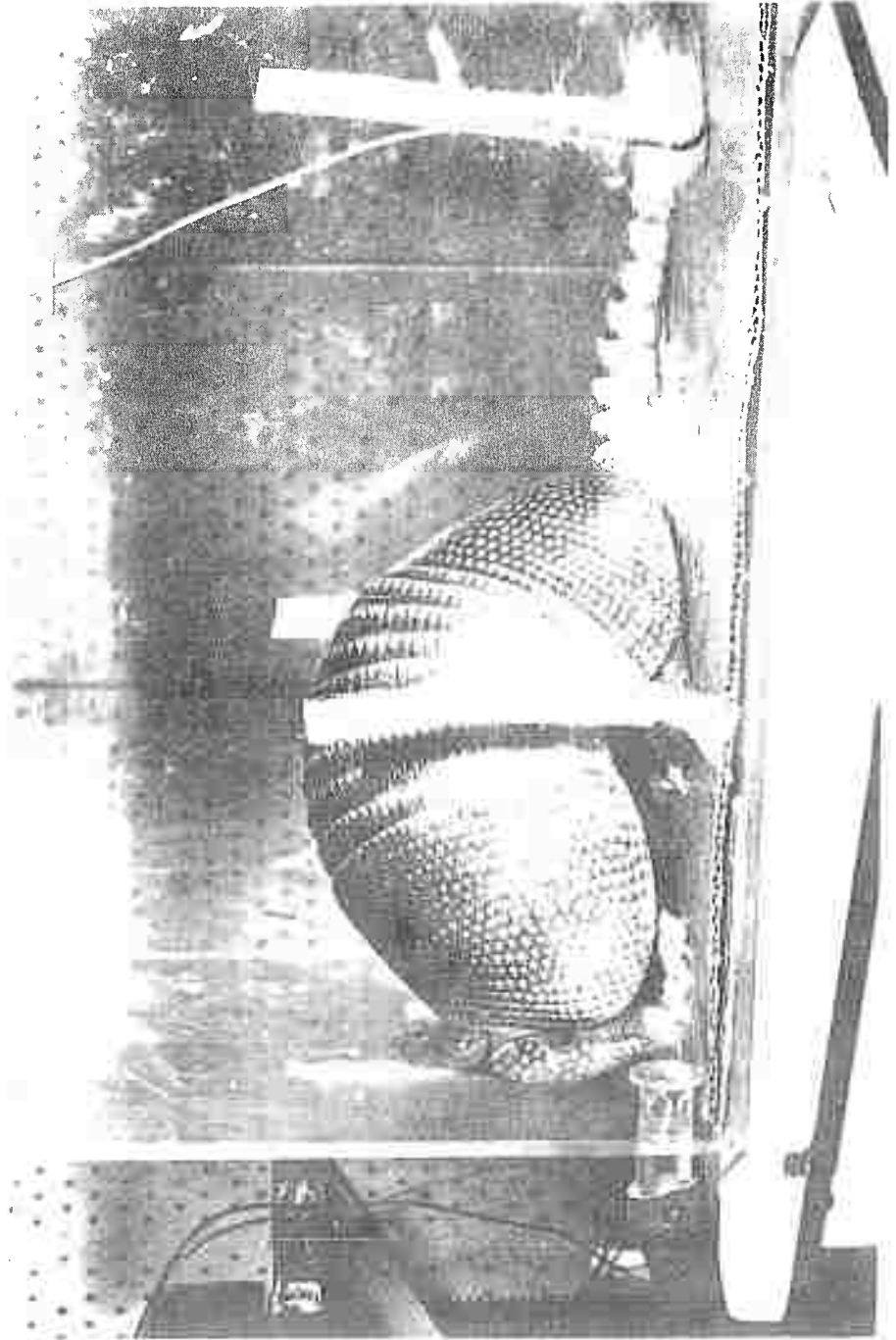

Figure 9b. Photograph showing an armadillo in the metabolism chamber. The air temperature is slightly lowered (20°C), and the animal shows typical crouched posture. (Johansen, 1961).

JOHANSEN

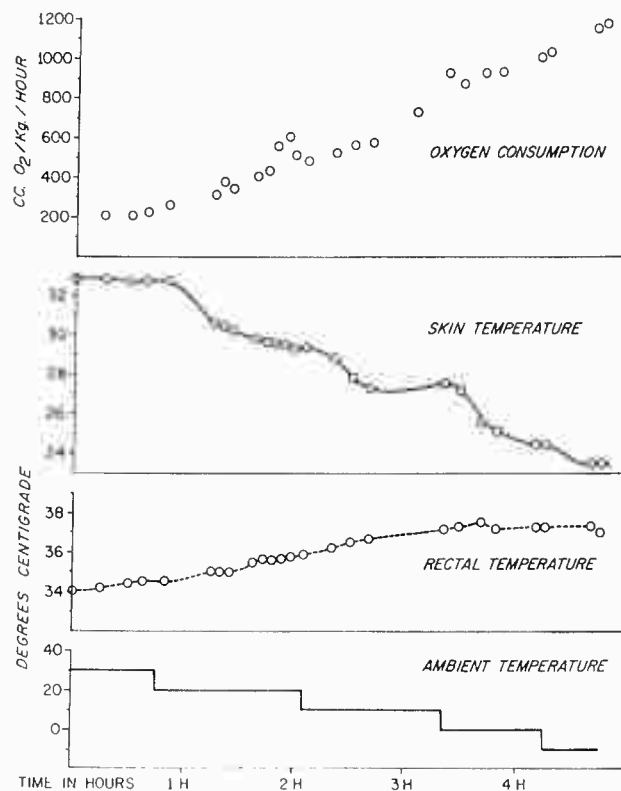

Figure 10. Oxygen consumption and deep rectal and skin temperature at various ambient temperature levels in the armadillo. (Johansen, 1961).

EVOLUTIONARY ASPECTS IN MAMMALS

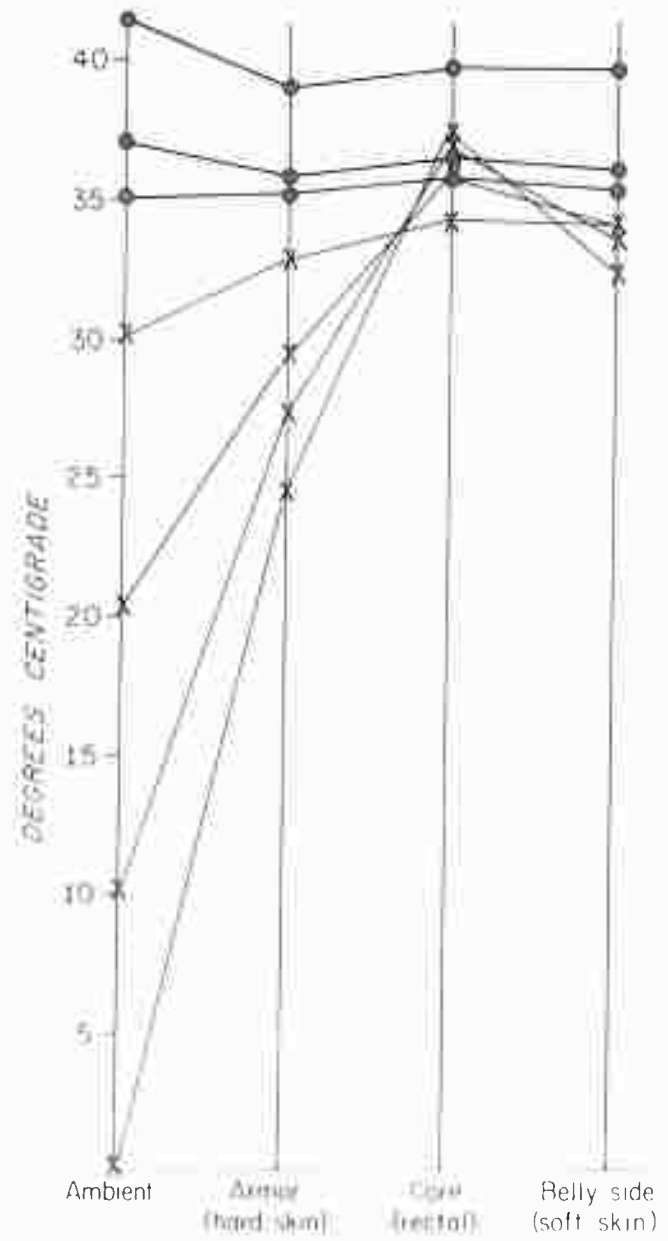

Figure 11. Schematic representation of temperature gradients between core and dorsal and ventral sides of armadillos at different air temperatures. (Johansen, 1961).

increase from 34.3°C to 35.4°C in less than 30 minutes. This increased core temperature seemed to result initially from a decrease in heat loss brought about by a vasoconstriction in the body surface. Then 15 to 20 minutes after the onset of vasoconstriction the oxygen uptake increased. The increase in oxygen consumption was correlated with the start of shivering, which apparently can be evoked in armadillos by the slightest stimulus. In fact, shivering and an attendant increase in body temperature were occasionally observed when the room temperature was as high as 30°C . When exposed to cold, the animal immediately arose and tucked his head under his belly. His posture was ball-like and only a very small portion of the soft skin on the ventral side was directly exposed to the cold air (Fig. 9B). The increase in body temperature upon a decrease in air temperature did not occur only with the first cold stimulus. On the contrary, each time the temperature decreased the animal's body temperature rose immediately (Figs. 10 and 11). Even when the air temperature was decreased from 0°C to -10°C , and the animal already had a very high heat production, the body temperature rose. On one occasion when the change was from 0°C to -6°C , the rectal temperature increased from 35.7°C to 36.1°C in less than 10 minutes. During the stepwise decrease of ambient temperature from 30°C to -10°C in a period of 5 hours, the total increase in rectal temperature was 3.5°C (Fig. 10) and the body temperature on the armor decreased about 10°C to 23°C . These temperature changes occurred in a step-like pattern following the changes in air temperature. Upon a sudden decrease in air temperature from 30°C to 0°C , the rectal temperature rose 2°C in 40 minutes. But this increase was not as great as was the total response to step-reductions from 30°C to 20°C to 10°C to 0°C . This very conspicuous increase in rectal temperature upon cold exposure has to my knowledge not been reported before. It may have escaped notice because rectal temperatures were not continuously recorded. Bartholomew, in his paper on *Setonix* (1956) makes the statement that at -10°C , the animal kept an elevated body temperature for quite some time during the exposure period. Meanwhile, he did not persuade this point further in his discussion. In my interpretation, this fact, so very explicitly demonstrated in the armadillo, shows that the effector mechanisms that modify heat loss, like vasoconstriction, etc., operate very promptly but entirely out of pace with

EVOLUTIONARY ASPECTS IN MAMMALS

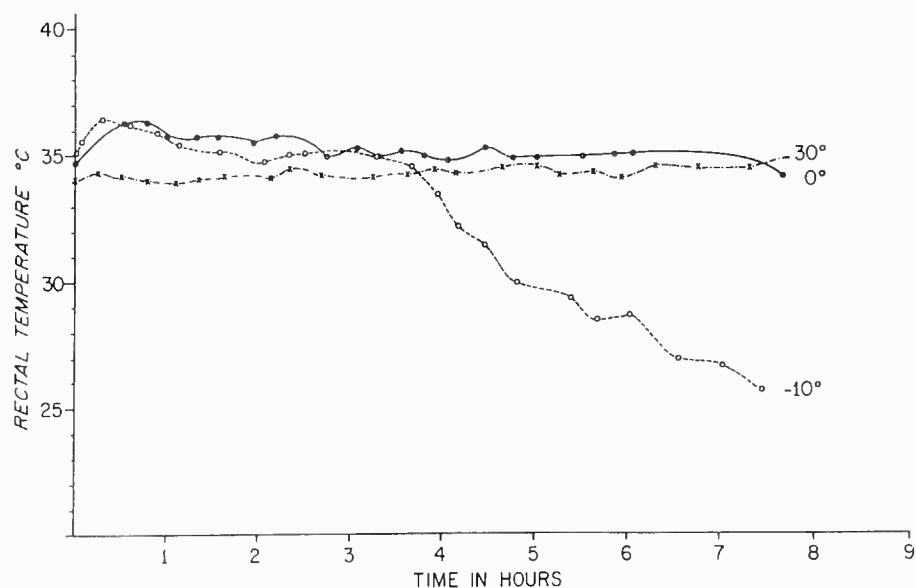

Figure 12. Continuous records of deep rectal temperatures of the armadillo at various air-temperature levels. (Johansen, 1961).

the governing thermostatic control which fails in the armadillo with several degrees. You may rightly ask how long this unsteady condition goes on. Figure 12 demonstrates the events during long-time exposure to various ambient temperatures. When an experiment began at 30° C, the deep rectal temperature fluctuated between 33.9° C and 34.5° C, as can be seen in Figure 12. The animals were quiet and relaxed. Occasionally they walked around, but the activity was always transient and on a low level. The animals responded to an air temperature of 0° C with a rapid increase in body temperature like that recorded in the metabolic studies. This response was accompanied by curling into a ball as described earlier, and shivering began immediately. These bodily responses continued throughout the test. At the end the animal showed no signs of exhaustion. The curve for 0° C in Figure 12 illustrates the typical variation in deep rectal temperature. It rose rapidly to 36.3° C in this animal within the first half hour. After an hour the temperature dropped slightly to 35.5° C and remained between 35° C and 35.5° C for more than 6 hours. Toward the end of the

exposure, the temperature dropped slightly; the last temperature recorded in this animal was 34° C. In similar experiments at -10° C, the initial increase in rectal temperature was even more rapid and pronounced (Fig. 12). After slightly more than an hour, the rectal temperature had declined to the level recorded at the beginning of the experiment. For the next $2\frac{1}{2}$ hours the temperature fluctuated around 35° C. Then suddenly the animal began to run about the room scratching at the walls, the rectal temperature started to drop, and within five hours it had fallen to 25.5° C. At this low body temperature, the animal showed no signs of severe fatigue and was amazingly coordinated. Its movements were harmonized and it eagerly drank some milk which it was offered. The highly organized behavior at such a low body temperature seems to be unique among non-hibernating mammals and is probably of great functional value to the armadillo. Although the pattern of -10° C shown in Figure 12 is typical, the length of time the body temperature was maintained near 35° C varied from animal to animal, being less than $2\frac{1}{2}$ hours in some and as long as $5\frac{1}{2}$ hours in others. The period of relatively constant temperature terminated when the animal abandoned the protective posture, which no doubt provided good insulation. It should be emphasized that this kind of exposure does not at all give a true picture of the armadillo's tolerance to severe cold in natural environments. It will be pointed out later that the armadillo is very much concerned with and dependent upon nest building and social habits for survival at low ambient temperatures.

I should like to spend a few minutes commenting upon the intactness of coordinated behavior at drastically low body temperatures. Other workers have mentioned the fact that normal behavior persists at very low body temperatures in many primitive animals. This fact has, however, never been appropriately evaluated. It strikes me since it is a common characteristic among most of the lower mammals studied in this respect. Comparing this with the lethargic condition and the concurrent impairment of coordination that appear in higher mammals, for example carnivores and ungulates at temperatures which are for them only slightly hypothermic (30° C to 33° C), it seems of the highest significance. I think the persistence of coordinated behavior at low body temperatures in primitive forms has great survival value and greatly

EVOLUTIONARY ASPECTS IN MAMMALS

increases their independence from the environment. I think, furthermore, that this is an important point in the phylogeny of homeothermy and more than anything that it should be subjected to further study.

My data on the tolerance to cold in a long-time experiment differs markedly from apparent results of earlier investigations on armadillos. The conspicuous increase in rectal temperatures has not been reported previously and it may have escaped notice because the rectal temperatures during cold exposure were not continuously recorded. Wislocki (1933) observed the following rectal temperature patterns in armadillos transferred from 28° C to 0° C air temperature: at 0 time, 35° C; at 1-hour exposure, 34° C; at 2-hour exposure, 31.5° C; at 3-hour exposure, 30° C. Recently, Enger (1957) reported that the armadillo, opossum, and three-toed sloth are poor thermal regulators and lose body heat to a considerable extent during a cold stress, that is, 4 to 6 hours at 10° C air temperature. These results differ basically from those of the present study. It would be highly desirable to determine whether this difference stems from the fact that Wislocki's and Enger's measurements were made on animals from a strictly tropical habitat, Barro Colorado, in Panama, whereas the subjects of this study came from Texas. This would be a most notable demonstration of adaptation to cold.

The increase in oxygen consumption upon lowering of the air temperature for a representative experiment is shown in Figure 10, and for all experiments in Figure 13. There was more than a five-fold increase in oxygen uptake when the air temperature was reduced from 30° C to -10° C. The relatively great spread in the data at the lower temperatures is probably related to the differences in the rectal temperatures of different animals. No attempt was made to test responses to temperatures below -10° C because some animals try to escape exposure to this temperature. These activities of course involved the abandonment of the protective posture and large losses of heat occurred. Ordinarily the animals showed an amazing ability to remain crouched in their ball-like posture for hours when the temperature was as low as 0° C.

EVOLUTIONARY ASPECTS IN MAMMALS

increases their independence from the environment. I think, furthermore, that this is an important point in the phylogeny of homeothermy and more than anything that it should be subjected to further study.

My data on the tolerance to cold in a long-time experiment differs markedly from apparent results of earlier investigations on armadillos. The conspicuous increase in rectal temperatures has not been reported previously and it may have escaped notice because the rectal temperatures during cold exposure were not continuously recorded. Wislocki (1933) observed the following rectal temperature patterns in armadillos transferred from 28° C to 0° C air temperature: at 0 time, 35° C; at 1-hour exposure, 34° C; at 2-hour exposure, 31.5° C; at 3-hour exposure, 30° C. Recently, Enger (1957) reported that the armadillo, opossum, and three-toed sloth are poor thermal regulators and lose body heat to a considerable extent during a cold stress, that is, 4 to 6 hours at 10° C air temperature. These results differ basically from those of the present study. It would be highly desirable to determine whether this difference stems from the fact that Wislocki's and Enger's measurements were made on animals from a strictly tropical habitat, Barro Colorado, in Panama, whereas the subjects of this study came from Texas. This would be a most notable demonstration of adaptation to cold.

The increase in oxygen consumption upon lowering of the air temperature for a representative experiment is shown in Figure 10, and for all experiments in Figure 13. There was more than a five-fold increase in oxygen uptake when the air temperature was reduced from 30° C to -10° C. The relatively great spread in the data at the lower temperatures is probably related to the differences in the rectal temperatures of different animals. No attempt was made to test responses to temperatures below -10° C because some animals try to escape exposure to this temperature. These activities of course involved the abandonment of the protective posture and large losses of heat occurred. Ordinarily the animals showed an amazing ability to remain crouched in their ball-like posture for hours when the temperature was as low as 0° C.

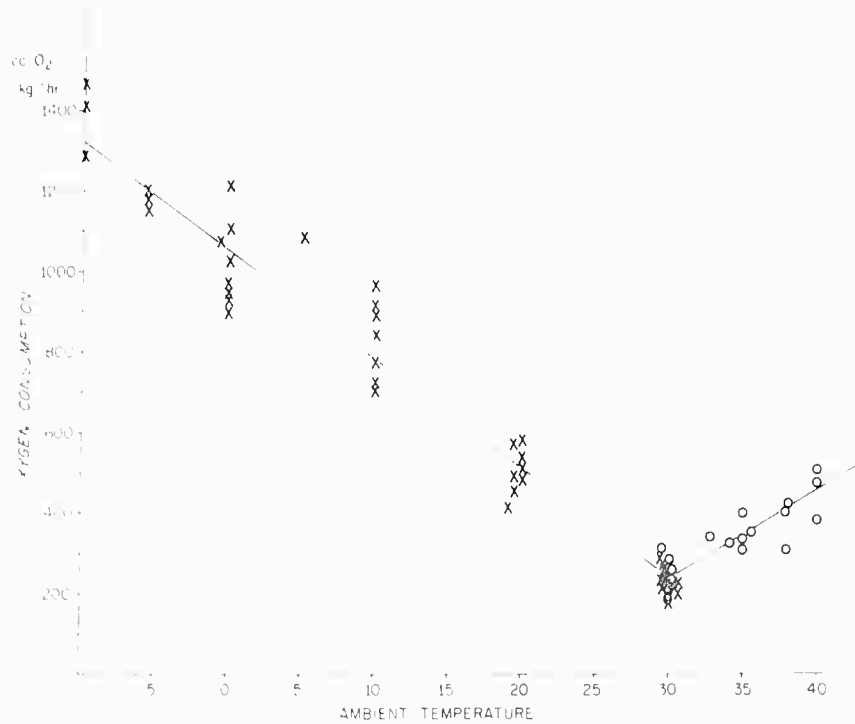

Figure 13. Oxygen consumption versus ambient temperature for the armadillo. (Johansen, 1961).

In the light of the observations on the metabolic response to cold, I find it proper to discuss briefly the concept we all have been repeatedly informed about, namely that the effector mechanisms affecting heat dissipation and conservation, what we call physical temperature regulation, come first into play and reach their effective limits before metabolic compensation sets in. In other words, at the point of the critical temperature, the ability for physical regulation is exhausted. This fact has been repeatedly stated from studies on temperate and arctic mammals and has received value as a concept in our understanding of temperature regulation. I can see no reason why this strict sequence has to have general value. Martin's data on the platypus and the marsupials indicate a gradual, simultaneous time of action for both processes. My own data on the armadillo likewise support the idea that maximal insulation, including vasomotor adjustment, does not necessarily need to reach the end point before metabolic compensation sets in. The sequential arrangement has, of course, an obvious biological rationale, by saving fuel. However, in line with my earlier

EVOLUTIONARY ASPECTS IN MAMMALS

reasoning I feel that such a strict sequential play-off of the compensatory mechanisms will require a rather precise central nervous thermostatic control which in many forms may not have reached the perfection needed.

For the metabolic rate of the armadillo, my studies showed a low resting value of about 250 cc/(kilo x hr) at an air temperature of 30° C. These measurements are in accord with those reported by Scholander et al. (1943). They found values averaging 180 cc/(kilo x hr) and varying between 150 and 280. These values are roughly half the size of those reported by de Almeida and de A. Fialho (1924). However, Scholander et al. felt that the experimental approach may have been a factor in the recording of the high values by these authors. The resting metabolism of the armadillo, then, is obviously less than that common in mammals of the same size. It is slightly more than half that simultaneously measured in rabbits of comparable size. The measured metabolic rate in rabbits corresponded with values given by Benedict in 1938. The resting metabolism of the armadillo, although somewhat higher, approaches that found in sloths by Irving et al. (1942). Martin (1903) reported an air temperature of 30° C coinciding with the lowest metabolic value for the monotremes, Echidna and Ornithorhynchus, and for several marsupials. Throughout the whole temperature range studied, Martin found the metabolism to be lower in monotremes and marsupials than in higher mammals like cats and rats. The question arises: Is this low level of resting metabolism related to the low resting body temperatures found in these species? The results of my study on the armadillo suggest that this may be partly true, but that differences in the thermostatic mechanisms are also important factors in the dissimilarity between the armadillo and more advanced homeotherms. For the same reason critical temperatures and critical gradients are more or less meaningless when applied to these species. As mentioned, the armadillo will occasionally start shivering and increase its body temperature at an air temperature of 30° C. The word "critical," as in critical temperature and critical gradient, is obviously not pertinent to this situation. Martin argued similarly that the low metabolism in monotremes and marsupials can result from the following factors: a greatly diminished heat loss, a lower body temperature level, and failure to maintain a constant body temperature.

The increase in heat production when air temperature declines has several noteworthy features. The steepness of the slope of metabolism versus air temperature is fairly great and of about the same magnitude as for the two-toed sloth. The fact that the naked armadillo and the hairy sloth with about the same resting metabolism showed similar regressions in this respect supports the idea that the armadillo has a potent vasoconstrictor ability. The fact that the armadillo showed a step-wise increase in insulation may, however, somewhat invalidate comparison of it to the sloth. The peak metabolic values in the armadillo vary from five to six times larger than the resting values. Such high metabolic rates were recorded for as long as 6 hours, which was the longest time oxygen consumption was measured at one fixed low temperature. According to Scholander et al. (1950) the maximum increase in heat production is time-dependent and seldom more than four times the resting value. They state that this relation is valid for long-time experiments, but they do not define "long time." In the armadillo the increased heat production results from a progressive augmentation of shivering. The shivering pattern is closely related to the crouched posture and the armadillo rarely utilizes moving about as a means for increasing heat production in the cold. Occasionally when they abandoned the immobile posture, the animals experienced great heat losses. To demonstrate more explicitly the difference in metabolism and response of body temperature to cold exposure, I did some experiments with rabbits. In Figure 14, we can see that deep rectal temperatures and oxygen consumption were followed at various ambient temperature levels ranging from $+30^{\circ}\text{C}$ to -6°C . At 30°C air temperature, the rectal temperatures of the armadillos are more than 4°C lower than for the rabbits. Upon a gradual step-wise decrease in air temperature, the armadillos show an increasing body temperature, accompanied by a steep increase in oxygen consumption, whereas the rabbits' condition is unchanged. The procedure lasted 4 to 5 hours. These studies demonstrate a conspicuous over-compensation to the cold stress in the armadillo. In other words, the body temperature is drastically raised at the expense of an increased metabolism. The fact that this over-compensation takes place so rapidly and to such a large extent

EVOLUTIONARY ASPECTS IN MAMMALS

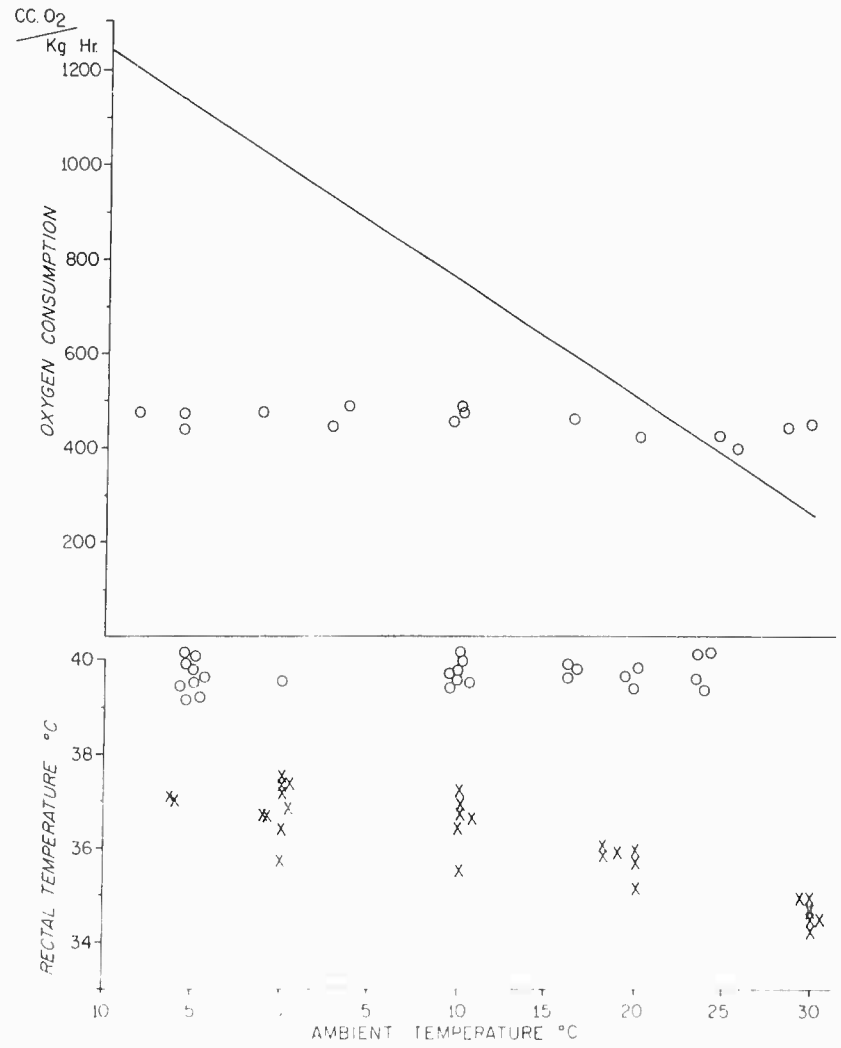

Figure 14. Comparison between oxygen consumption and deep rectal temperatures for armadillos and rabbits at different ambient temperature levels. Open circles indicate rabbit data; crosses and regression line indicate the results from the armadillo experiments. (Johansen, 1961).

demonstrated the presence of well-developed mechanisms for compensatory heat production. However, this heat production and conservation are not governed by the same thermostatic arrangements that are present in rabbits.

Grant me also a few words about insulation in the naked armadillo. The very large temperature gradients in the extremities and snout shortly after the beginning of cold exposure are likely of great significance (Figs. 15, 16, and 17). It is interesting to compare this observation with those of Scholander and Krog on the sloths from 1957. These investigators suggest that the vascular bundles rete mirabile in the limbs of the sloths strongly facilitate the conservation of central body heat at the expense of a profound cooling of the limbs. The principle involved is thought to be a counter-current heat exchange in the vascular bundles which provide a greatly enlarged contact surface between the counter-streaming arteries and veins (Scholander and Schevill, 1955; Scholander, 1958). In the sloth, subcutaneous temperature gradients in the legs were as

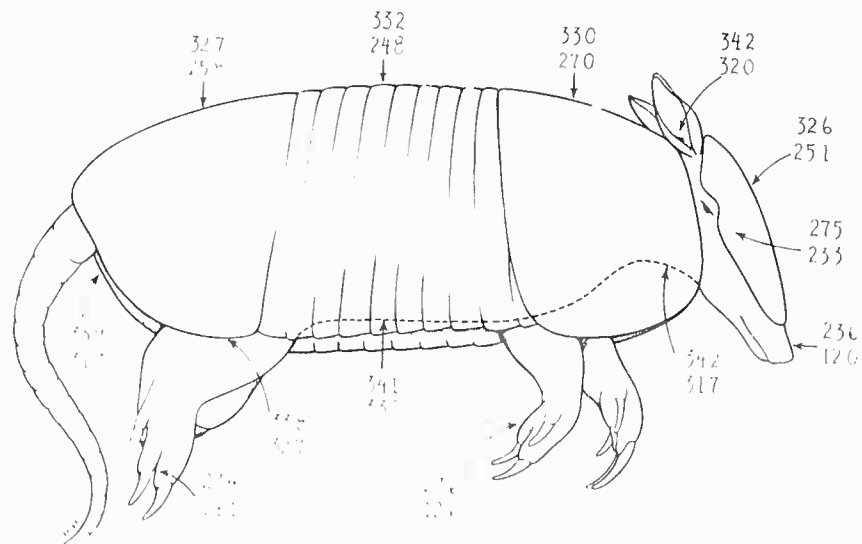

Figure 15. Cutaneous temperatures at various sites on the armadillo's body at air temperatures of 25^o C - 30^o C (upper numbers) and 5^o C (lower numbers). (Johansen, 1961).

EVOLUTIONARY ASPECTS IN MAMMALS

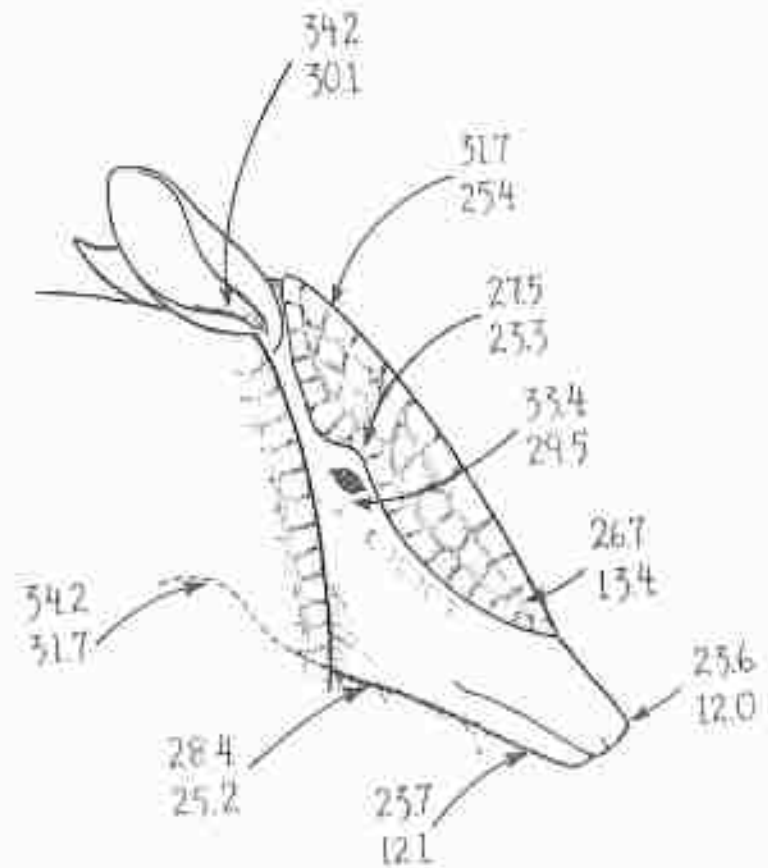

Figure 16. Cutaneous temperatures at various sites on the armadillo's body at air temperatures of 25° C - 30° C (upper numbers) and 5° C (lower numbers). (Johansen, 1961).

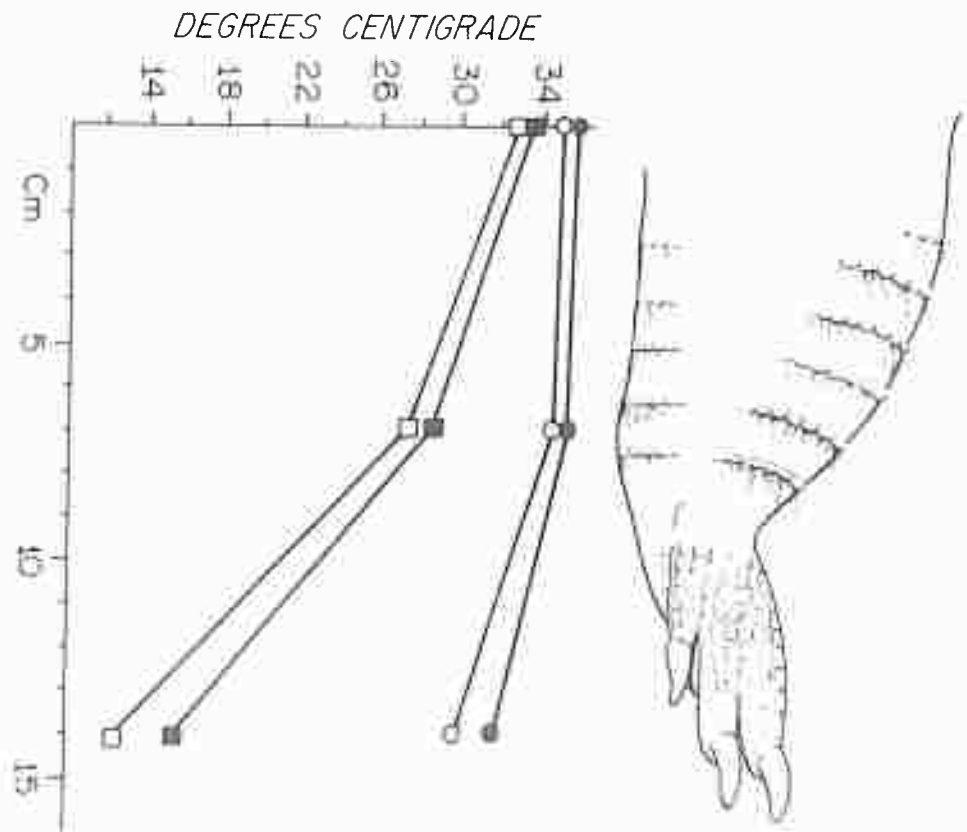

Figure 17. Intramuscular and subcutaneous temperature gradients along the hind extremity of an armadillo. Open circles and squares show subcutaneous gradients; filled circles and squares, intramuscular gradients. Circles are recordings taken at air temperature of 25° C; squares at 0° C. (Johansen, 1961).

EVOLUTIONARY ASPECTS IN MAMMALS

great as 0.2° C per cm at ambient temperatures of 25° C to 27° C. Such gradients are 10 times steeper than those in the human arm under similar conditions. The same vascular structures are present in the limbs of other living Xenarthra, the anteaters and the armadillos. The present study, showing very large temperature gradients at low air temperatures, was not designed to verify the counter-current hypothesis and can give no conclusive evidence in this respect.

We note from the important works of Irving and Scholander and associates that the insulative value of animals generally increases as we proceed north and south to the arctic and antarctic regions. The almost unbelievable insulation attained by some of the larger arctic mammals, like the husky, the wolf, and the fox, makes possible a maintained resting metabolism down to 60° C to 70° C below zero. This fact, I think, poses an interesting question: How do these animals get rid of the excess heat produced during the extensive exercise they necessarily have to practice? You may think that panting is enough to keep the body temperature at so-called normal levels of 37° C to 38° C. I have done this winter some measurements on the exercising husky sled dogs. The results show that shortly after the start of exercise, both intramuscular and deep rectal temperatures reach levels of about 41° C to 42° C in an air temperature down to -50° C. These surprisingly high temperatures did not in any way impair the performance of the dogs, which could keep on working for 6 to 8 hours at the same speed, allowing only brief periods of rest. Studies done on dogs from warmer temperate regions indicate an impairment of function and heat collapse at lower body temperatures, down around 41° C. Although few data are available so far, it seems probable that the unbelievably great insulation of some of the arctic mammals has resulted in an adaptive tolerance to an elevated body temperature. At least the husky provides information in this direction. My studies on the heavily insulated muskrat indicate an entirely different solution to the problem. Time seems, however, to prevent us from going into this.

JOHANSEN

Let us next look at the physiological responses to high air temperatures in the armadillo. Figure 18 shows the changes in rectal and skin temperatures and oxygen consumption when the ambient temperature was increased above 30° C. The relative humidity was kept below 30%. As the air temperature was increased in steps to 42° C over 4 to 5 hours, the rectal temperature rose to 40° C. If the air temperature was increased from 30° C to 42° C in one step, the rectal temperature reached 40° C in less than 3 hours. From the behavior of the animals, 40° C seems near the upper lethal limit for the rectal temperature, although 41.5° C was repeatedly tolerated for periods of less than 1 hour. The skin temperature on the back armor rose markedly in a step-wise fashion following the changes in room temperature. The skin remained completely dry, however, and no active sweat glands were detected with either of the two methods used. The circulation to the skin was greatly augmented; even the dorsal armor blushed pinkish red. The ears were markedly vasodilated, constantly vibrating. At high air temperature panting is an important avenue of heat loss for the armadillo. The respiratory rate rose from 30 to 40 breaths a minute to almost 200 a minute. The greatest increase in rate seemed to occur when the rectal temperature was between 37° C and 38° C (Fig. 19). During panting the nostrils were red and vibrating intensely. There seemed also to be a rather profuse salivation from the buccal mucosa. However, no licking ever occurred. The oxygen consumption rose from about 240 cc/(kilo x hr) to 400 cc/(kilo x hr). Part of this increase was related to the muscular activity of hyperventilation, part to the elevated rectal temperature. The significance of panting in the armadillo's response to heat was demonstrated by anesthetizing an animal when its body temperature was about 38° C and the air temperature was 40° C (Fig. 19). As soon as the respiratory rate was depressed to normal or subnormal levels, the rectal temperature rose sharply. During exposure to the hot environment, the animals usually turned on their sides immediately, stretching their front legs forward and their hind legs backward so that their ventral surface was maximally exposed. When the rectal temperature was 40° C, the animals were obviously uncomfortable and some attempted to escape.

EVOLUTIONARY ASPECTS IN MAMMALS

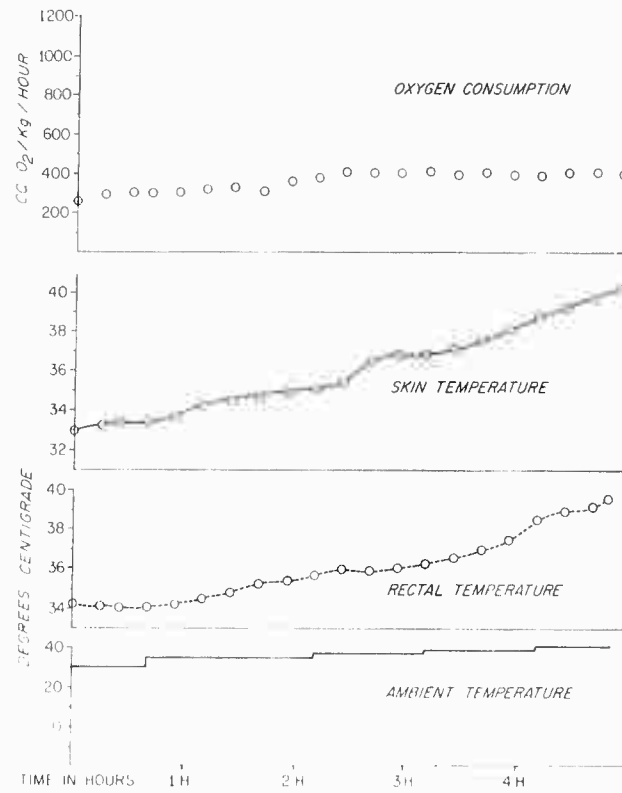

Figure 18. Oxygen consumption and deep rectal and skin temperatures at various ambient-temperature levels in the armadillo. (Johansen, 1961).

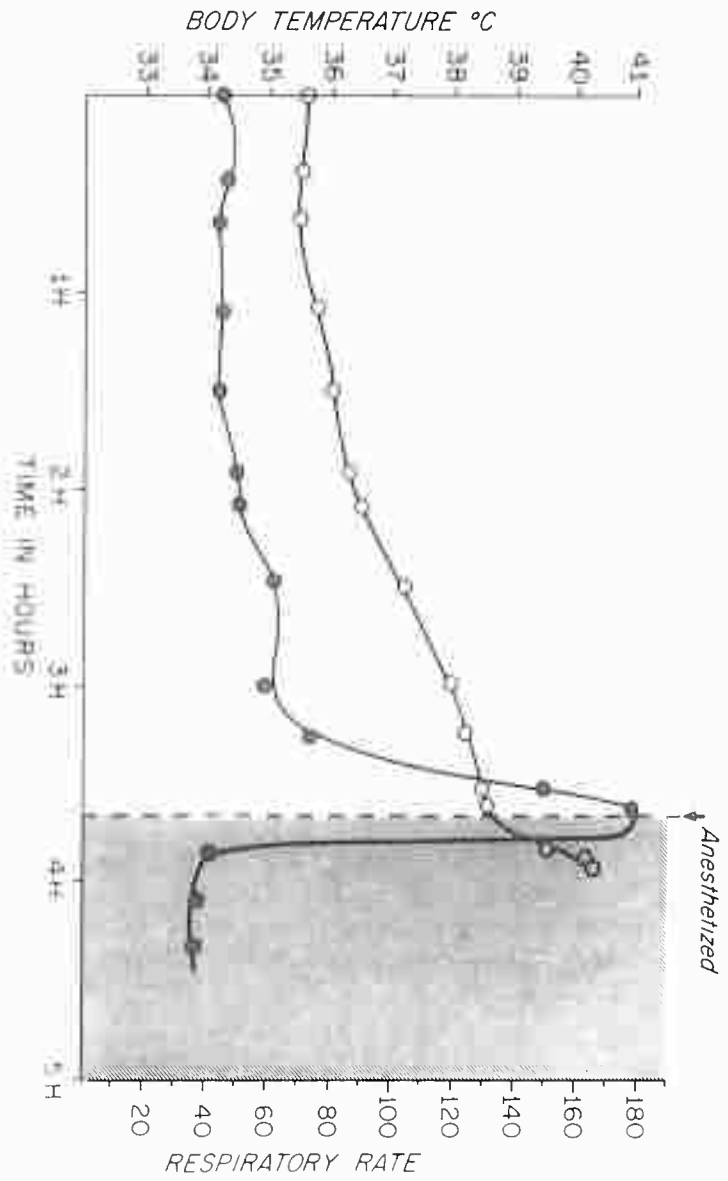

Figure 19. Deep rectal temperature and respiratory rate at an air temperature of 40° C. Open circles show deep rectal temperatures; filled circles, respiratory rate. (Johansen, 1961).

EVOLUTIONARY ASPECTS IN MAMMALS

Next, I have a few closing words about the role of behavior. The almost unbelievable achievement in the temperature regulation of reptiles, reached solely by behavioral means, ought to be a strong reminder to all of us that we can also reasonably expect behavior to play a crucial role in temperature regulation in mammals. This I am sure we all agree upon, but in our laboratory experiments we necessarily have to dispense with most of the subjects' opportunities for behavioral regulation. Our knowledge regarding the role of behavior in the physiological phylogeny of temperature regulation is therefore very limited. In the monotremes it is of paramount importance. In the primitive *Echidna* behavior seems to be the only way heat dissipation can be effected and is thus of vital consequence, particularly on the hot side. To evaluate the importance of behavior along the phylum is virtually impossible, and I will make no attempt to do so. With the increasing development of the cerebral capacity, behavior may reach ultimate sophistication in man with his air-conditioned houses. Physiologists and anthropologists have thus taught us that man's invasion of the climatic extremes, such as the Eskimos, Lapps, and others, is almost entirely achieved by behavior, with rather subtle changes in physiological adaptation. Since we are discussing evolution, it may be of interest that behavior may also show regression as a factor in human temperature regulation. I am referring to man's or more correctly, woman's vanity, explicit in sheer nylon stockings in 40° C below weather, readily observable in the streets of Fairbanks every winter.

An important part of the armadillo's temperature regulating ability is represented by its behavioral pattern. Thus, there is no doubt that the ball-like posture is an extremely important means of increasing the insulation. Measurements made by Buttner (1938) demonstrate a reduction of 50% in the surface area when a man curls into ball-like posture. The importance of posture was shown clearly for the armadillo as well by the skin temperature measurements and the experiments with the heat-flow discs. The building of nests is also a most important factor in survival during exposure. Without overstating it, nest-building seems to be a highly developed social habit which is of the greatest functional significance in the survival and expansion of the species. It is of particular interest in

this connection, as reported by Scholander et al. (1950) that some of the smaller arctic mammals with furry insulation like that of tropical mammals are dependent upon burrows and nest-building for their survival. Notably, measurements made by Scholander et al. showed that the insulative value of a lemming nest is roughly 1.5 times that of the lemming fur. If the nest is covered with snow, its insulative value would presumably be even greater. In considering the evolution of homeothermism, then, one must include behavioral patterns as essential and indispensable parts of the whole system.

The rather loosely connected information I have given you may qualify for a tentative outline of one probable way the evolutionary sequence of homeothermy has taken place. Figure 20 is an attempt to put the factors together, but only in a qualitative way, since measurements are lacking in most parts. The first successful efforts to maintain a fairly uniform level of body temperature began on the psycho-physiological or behavioral level. Such an achievement would necessitate a well-developed sensory system for temperature, as well as a nervous coordination of the effector mechanism,

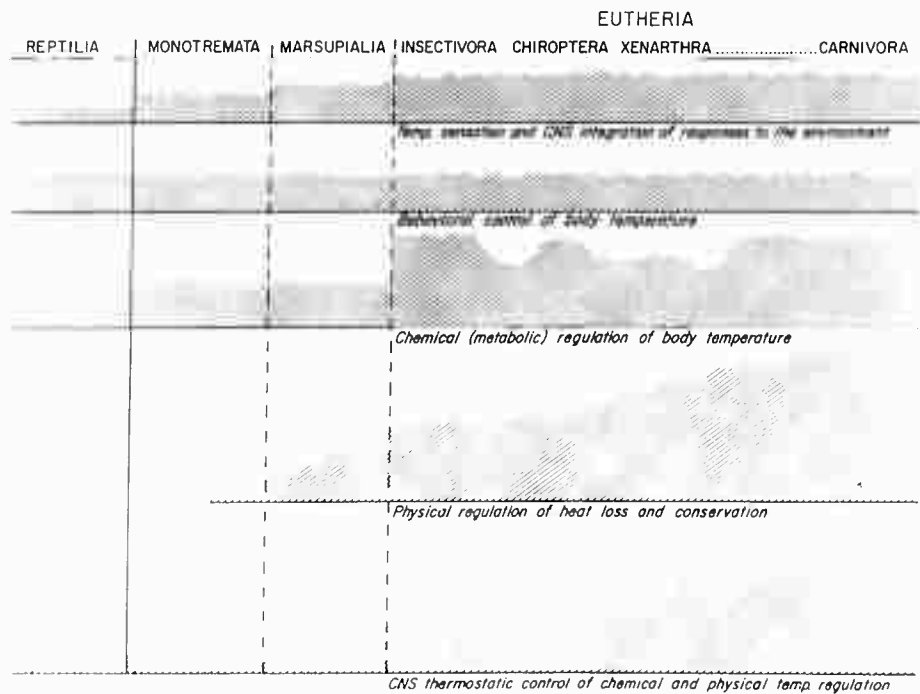

Figure 20. Simplified schematical drawing of a possible route for the evolutionary sequence of homeothermy in mammals. (Johansen, 1961).

EVOLUTIONARY ASPECTS IN MAMMALS

like locomotion, etc. The first directly physiological factor brought into the picture of homeothermy seems to have been a variation in metabolic heat production, thus for the first time releasing animal life somewhat from the environment. As discussed above such regulation has serious limitations, and collapse occurs at severely high air temperatures and outside the tropical stability. The next step toward advanced homeothermy seems to have been the appearance and development of the regulation of physical heat exchange. We can trace a gradual improvement of such function along the phylum but also closely correlated to the thermal stress imposed by the environment. We know from the important works of Irving and Scholander and associates that under the extreme conditions confronting the arctic mammals, homeothermy is first of all accomplished and maintained by adjustment of the shell-core temperature gradient--or in other words, by adjustments of the insulation. The efficient regulation of temperature under changing conditions in the environment must ultimately be entirely dependent upon an integrated control of heat loss and heat exchange by thermostatic arrangements. These thermostatic arrangements have reasonably developed gradually becoming increasingly complex and accurate. The data provided by Bartholomew on Setonix, as well as my own data on the armadillo, I think, provides an example of animals whose temperature regulating ability has reached a stage where the degree of thermostatic control is a factor limiting the efficiency with which the animals maintain homeothermy. Efficient central nervous thermostatic control seems thus to have been the last factor developed to perfection in homeothermy.

If you will grant me another minute, I will admit that there is an obvious trend in the lower forms of mammals for body temperature to be characterized by a large range and a lower set average. In all treatments on the subject, however, this fact is regarded as typifying primitive forms and thus the evolution of homeothermy. It has been stated that the least variable factor in the whole picture of homeothermy is the body temperature. From my own data, as well as other information accumulated recently, I am strongly opposed to this view. In my mind it is entirely conceivable that a

JOHANSEN

large activity range of body temperature may express a specialization rather than a primitive condition. A truly fixed body temperature, fluctuating within very narrow limits, would for many species be highly uneconomical, or not at all obtainable in the special environments they face. This viewpoint gets support from my work on the birch mouse, a rodent which shows diurnal fluctuations in body temperature up to 20° C in the summer time (Johansen and Krog, 1959). The large activity range of the husky gives additional support. The work done on the camel by Schmidt-Nielsen et al. (1957) and on the rhinoceros by Albrook et al. (1958), and practically all the smaller animals subjected to thorough study recently show the same thing (Morrison and Ryser, 1959). Let us not forget Joseph Barcroft's words (1934) that every adaptation is an integration. Let us remember there is more to it than just keeping a constant core temperature. The effector systems involved in temperature regulation have other tasks to perform, which is so strikingly apparent from Schmidt-Nielsen's study on the camel. I am confident that when our knowledge of body temperature ranges during activity and other bodily performances, as well as sleep, is extended, this will disclose a larger range of body temperatures than we are familiar with. Let us not a priori let such a large temperature range be classified as a primitive sign. Moreover, I feel from my work on the armadillo that the specializations I have mentioned above can also develop in forms of lower phylogenetic ranking and thus complicate, and maybe somewhat invalidate, the body temperature range as a clear measure of the phylogenetic standing. I would like to submit this idea as a challenge to present concepts of temperature regulation.

Ed. note: The discussion of Dr. Johansen's paper was postponed into the following session due to lack of time. It is incorporated with the discussion of Dr. Irving's paper.

EVOLUTIONARY ASPECTS IN MAMMALS

LITERATURE CITED

1. Allbrook, D. B., A. M. Harthoorn, C. P. Luck and P. G. Wright. 1958. Temperature regulation in the white rhinoceros. *J. Physiol.* 143:51.
2. Almeida, O. de, and B. de A. Fialho. 1924. Temperature et metabolisme du tatou. *Compt. rend. Soc. biol.* 90:734.
3. Barcroft, J. 1934. Features in the Architecture of Physiological Function. Cambridge Univ. Press. 368 pp.
4. Bartholomew, G. A. 1956. Temperature regulation in the macropod marsupial, Setonix brachyurus. *Physiol. Zool.* 29:26-40.
5. Bartholomew, G. A. and T. J. Cade. 1957. Temperature regulation, hibernation and aestivation in the little pocket mouse, Perognathus longimembris. *J. Mammal.* 38:60-72.
6. Benedict, F. G. 1938. Vital Energetics. Carnegie Inst. of Wash. Publ. No. 503. 215 pp.
7. Bogert, C. M. 1949. Thermoregulation in reptiles, a factor in evolution. *Evolution.* 3:195-211.
8. Bolliger, A. and M. H. Hardy. 1944. The sternal integument of Trichosurus vulpecula. *J. Proc. Roy. Soc. N. S. W.* 78:122-133.
9. Britton, S. W. 1941. Form and function in the sloth. *Quart. Rev. Biol.* 16:13-34 and 190-207.
10. Britton, S. W. and W. E. Atkinson. 1938. Poikilothermism in the sloth. *J. Mammal.* 19:94-99.
11. Burrell, H. 1927. The Platypus. Sydney, Angus and Robertson, Ltd. 277 pp.

JOHANSEN

12. Buttner, K. 1938. *Physikalische Bioklimatologi*. Leipzig.
13. Cowles, R. B. and C. M. Bogert. 1944. A preliminary study of the thermal requirements of desert reptiles. *Bull. Am. Mus. Nat. Hist.* 85:265-296.
14. Darlington, P. J. 1948. Geographical distribution of cold blooded vertebrates. *Quart. Rev. Biol.* 23:105-23.
15. Eisentraut, M. 1932-33. *Biologische Studien im Bolivianischen Chaco*. IV. Die Wärme Regulation beim Kugelgürteltier (*Tolypeutes conurus* J. S. Geoff.). *Zeitschr. Vergleich. Physiol.* 18:174-85.
16. Eisentraut, M. 1955. Apropos de la Temperature de quelques mammiferes de type primitif. *Mammalia*. 19:437-443.
17. Eisentraut, M. 1956a. Der Winterschlaf mit seinen ökologischen und physiologischen Begleiterscheinungen. *Gustav Fischer Jena*. 160 pp.
18. Eisentraut, M. 1956b. Temperaturschwankungen bei niederen Säugetieren. *Zeitschrift für Säugetierkunde*. 21:49-52.
19. Enders, R. K. and D. E. Davis. 1936. Body temperature of some Central American mammals. *J. Mammal.* 17:165.
20. Enger, P. S. 1957. Heat regulation and metabolism in some tropical mammals and birds. *Acta Physiol. Scandinavia*. 40:161-66.
21. Herter, K. 1934. Körpertemperatur und aktivitet beim Igel. *Zeitschr. f. vergl. physiol.* 30:511-544.
22. Hesse, R. 1937. *Ecological Animal Geography*. John Wiley and Sons. 597 pp.
23. Higginbotham, A. C. and W. E. Koon. 1955. Temperature regulation in the Virginia opossum. *Am. J. Physiol.* 181:69-71.

EVOLUTIONARY ASPECTS IN MAMMALS

24. Irving, L., P. F. Scholander, and S. W. Grinnell. 1942. Experimental studies of the respiration of sloths. *J. Cell. and Comp. Physiol.* 20:189-210.
25. Irving, L. and J. Krog. 1955. Temperature of skin in the Arctic as a regulator of heat. *J. Appl. Physiol.* 7:355-66.
26. Johansen, K. and J. Krog. 1959. Diurnal body temperature variations and hibernation in the birch mouse Sicista betulina. *Am. J. Physiol.* 196:1200.
27. Johansen, K. 1961. Temperature regulation in the ninebanded armadillo (Dasypus novemcinctus mexicanus). *Physiol. Zool.* 34:126-144.
28. Kredel, F. E. 1928. Notes on the temperature of the sloth. *J. Mammal.* 1:48-51.
29. Krieg, M. 1952. Der Kaltestarre Kolibri. *Naturw. Rdsch.* 5, S. 25-26.
30. Lendenfeld, R. von. 1886. Zur Brutpflege von Echidna. *Zoologischer Anzeiger* 9: Jahrgang. 9 pp.
31. Miklouho-Maclay, N. de. 1883. Temperature of the body of Echidna hystrix. *Proc. Linn. Soc. New South Wales.* 8:425.
32. Martin, C. J. 1903. Thermal adjustment and respiratory exchange in monotremes and marsupials. A study in the development of homeothermism. *Phil. Trans. Roy. Soc. London B.* 195:1-37.
33. Martin, C. J. 1930. Thermal adjustment of man and animals to external conditions. *Lancet.* 2:561-567, 617-620, 673-678.
34. Morrison, P. R. 1945. Acquired homeothermism in the pregnant sloth. *J. Mammal.* 27:272-75.

JOHANSEN

35. Morrison, P. R. 1956. Temperature regulation in three Central American mammals. *J. Cell. and Comp. Physiol.* 27:125-137.
36. Morrison, P. R. 1957. Observations on body temperature in a hedgehog. *J. Mammal.* 38:254-255.
37. Morrison, P. R. 1959. Body temperature in some Australian mammals. I. Chiroptera. *Biol. Bull.* 116:484-497.
38. Morrison, P. R. and F. A. Ryser. 1959. Body temperature in the white-footed mouse, Peromyscus leucopus noveboracensis. *Physiol. Zool.* 32:90-103.
39. Morrison, P. R., F. A. Ryser and A. R. Dawe. 1959. Studies on the physiology of the masked shrew Sorex cinereus. *Physiol. Zool.* 32:256-271.
40. Rand, A. L. 1925. On the habits of some Madagascar mammals. *J. Mammal.* 16:89-104.
41. Robinson, Kathleen W. 1954. Heat tolerances of Australian monotremes and marsupials. *Austr. J. Biol. Sci.* 7:346-360.
42. Robinson, K. and P. R. Morrison. 1957. The reaction to hot atmospheres of various species of Australian marsupial and placental animals. *J. Cell. and Comp. Physiol.* 49:455-478.
43. Schmidt-Nielsen, K., B. Schmidt-Nielsen, S. A. Jarnum, and T. R. Houpt. 1957. Body temperature of the camel and its relation to water economy. *Am. J. Physiol.* 188:103-12.
44. Scholander, P. F., L. Irving and S. W. Grinnell. 1943. Respiration in the armadillo with possible implications as to its burrowing. *J. Cell. and Comp. Physiol.* 21:53-63.
45. Scholander, P. F., R. J. Hock, V. Walters, F. Johnson and L. Irving. 1950. Heat regulation in some arctic and tropical mammals and birds. *Biol. Bull.* 98-99:237-58.

EVOLUTIONARY ASPECTS IN MAMMALS

46. Scholander, P. F. and W. E. Schevill. 1955. Countercurrent vascular heat exchange in the fins of whales. *J. Appl. Physiol.* 8:279-282.
47. Scholander, P. F. and J. Krog. 1957. Countercurrent heat exchange and vascular bundles in sloths. *J. Appl. Physiol.* 10:405-11.
48. Scholander, P. F. 1958. Countercurrent exchange; a principle in biology. *Hvalradets skrifter.* 44:5-24.
49. Semon, R. 1894. Notizen uber die Korpertemperatur der niedersten Säugetiere (Monotremen). *Arch. ges. Physiol.* 58:229-232.
50. Sutherland, A. 1897. The temperatures of reptiles, monotremes and marsupials. *Proc. Roy. Soc. of Victoria. N. S.* 8:57-67.
51. Talmage, R. T. and G. D. Buchanan. 1954. The armadillo (*Dasyus novemcinctus*). A review of its natural history, ecology, anatomy and reproductive physiology. Rice Institute Pamphlets. 41 (No. 2):1-35.
52. Wardlaw, H. S. H. 1915. The temperature of *Echidna aculeata*. *Proc. Linn. Soc. N. S. Wales.* 40:231-258.
53. Winge, H. 1941. The Interrelationship of the Mammalian Genera. Vol. I. Monotremata, Marsupialia, Insectivora, Chiroptera. Edentata. Reitzels Forlag. Kobenhavn. 412 pp.
54. Wislocki, G. B. 1933. Location of testes and body temperature in mammals. *Quart. Rev. Biol.* 8:385-96.
55. Wislocki, G. B. and R. K. Enders. 1935. Body temperature of sloths, anteaters and armadillos. *J. Mammal.* 16:328-329.
56. Wood-Jones, F. 1923. The mammals of South Australia. (Govt. printer Adelaide).

COMPARATIVE PHYSIOLOGY
OF TEMPERATURE REGULATION

PART 2

Editors

JOHN P. HANNON
ELEANOR VIERECK

ARCTIC AEROMEDICAL LABORATORY
FORT WAINWRIGHT
ALASKA
1962

THE HETEROTHERMOUS CONDITION OF THE TISSUES OF WARM-BLOODED ANIMALS

Laurence Irving

Appreciation for the universality of physical laws began to develop toward the close of the eighteenth century as the metabolic production of animal heat was ascribed to combustion. Lavoisier (1777) estimated that the heat caused by formation of the carbon dioxide expired by a rabbit was nearly equivalent to the heat which the animal gave off to a calorimeter, and he confidently attributed the production of heat by animals to processes of oxidation.

In 1840 Julius Robert Mayer, a young physician in Java, followed the then prevailing custom of bleeding sailors as they arrived in a tropical port. When he observed that the venous blood appeared arterial red he consulted with a colleague and was informed that in Java venous blood appeared arterial in color. His imagination led him to think that the diminished need for metabolic heat in a tropical climate brought about less reduction of oxygen in the venous blood than was usual in a colder climate. Reflecting upon this dubious explanation, he was led to produce comprehensive physiological and astronomical illustrations of the transformation of energy, from which he developed the general view of the conservation of energy (Tyndall, 1898). Mayer's explanation of the color of venous blood does not sound valid, however, for people in warm and cold climates have about the same basal production of heat, adjusting the elimination of heat to the climate by varying the circulation and temperature in their skin.

ARCTIC CLIMATE

Cold northern climates are advantageous for studying thermal reactions of animals because the winter weather is so much colder than the bodies of warm-blooded animals. Over the northern interior of Asia and America extreme seasonal changes occur. At Allakaket

IRVING

in the Koyukuk Valley of interior Alaska just north of the arctic circle the lowest temperature during the mild winter of 1959 was -59° C, and the warmest day in June was $+29^{\circ}$ C. On April 3, -36° C was recorded, and on April 11, the temperature rose to $+13^{\circ}$ C (U. S. Weather Bureau, 1960). Residents of the Arctic encounter large annual variations and precipitous rise of temperature in spring.

Stable Physiology of Arctic Populations

History indicates the presence of Eskimo people in the American arctic for 1,000 years before the first Norse settlers described them in southwest Greenland. Archaeological study of flint implements indicates that an Eskimo type of culture has been in the American Arctic for 2,000 years, and the ancestry of the Eskimo race in Alaska is probably as old as the traces of its culture. The stability of these people shows that their arctic existence was not uncertain and that it was secured by good adaptation to arctic life.

Relics of mammals indicate that species now living have been stable in form for several hundred thousand years. In the last part of this period drastic climatic changes have occurred; 6,000 years ago the north was warmer than now, and some 20,000 years ago most of Canada and much of Alaska was thickly covered by great ice fields. The ancestors of arctic animals have been exposed to pronounced variations in climate during a few thousand years. Although many generations succeeded each other in that time, the evolution of new species is not apparent. The arctic species must have long possessed physiological characteristics which were adaptable without evolutionary change in form to the recent climatic variations through which they have successfully passed.

Although relics of animals of the past provide little direct evidence about their physiology, systematic comparisons of physiological characteristics indicate that the principal mammalian and avian thermal processes have been stable since nearly the origin of the warm-blooded habit. In arctic Alaska John Krog and I (1954) found a fair sample of the few species of arctic mammals and resident birds and observed that their body temperatures did not differ significantly from those of animals of warmer climates. In fact among all of the

HETEROTHERMY IN HOMEOTHERMS

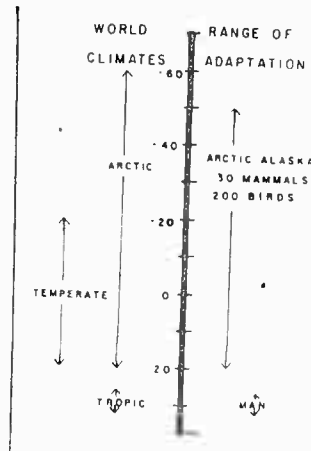

Figure 1. Temperature ranges for which warm-blooded animals are physiologically adapted compared with those of the world's climates. Redrawn from Figure 16, page 33, "Birds of Anaktuvuk Pass, Kobuk, and Old Crow." Bulletin 217, U. S. National Museum. 1960.

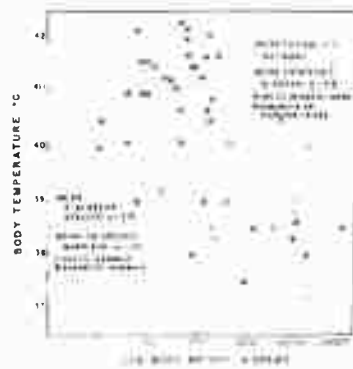

Figure 2. Mean body temperature of arctic and subarctic birds and mammals. Figure 6, page 677, "Body Temperatures of Arctic and Subarctic Birds and Mammals." JAP. 6(11):667-680. 1954.

species of mammals that regulate their temperature well when at rest, there is a difference of only a few degrees. Body temperatures do not now differ geographically, and the comparative view indicates that little scope for variation in warm body temperature has occurred in the course of evolution. There may be evidence for ancient separate development of warm body temperature in birds and mammals, but the heat producing machines of the two warm-blooded classes operate at nearly the same temperature. The reptilian metabolic system was already so elaborately developed that its evolutionary modification for warmer operation was limited within a narrow range of temperature (Fig. 2).

Economy of Heat Among Arctic Animals

Watching the caribou in winter in Alaska, I have been impressed by the large amount of time that they expend resting and carrying on individual and social activities that bring them no food, for while living in warmer climates I had thought that arctic mammals must feed diligently in order to combat the arctic cold with metabolic heat. But Scholander and I (1950a) found at the Arctic Research Laboratory that even in the coldest temperatures the warmth of well-insulated arctic birds and mammals could be sustained with metabolism at the resting rate. Because of this economy the cost of maintaining bodily heat for existence in arctic cold does not exceed the metabolic cost of living in warm climates. Insulation adaptive to the vicissitudes of the arctic climate opens the north for occupation by warm-blooded animals without economic handicap.

Natural populations of birds and mammals including man engage in a great variety of time-consuming individual and social activities which organize their societies in order to pursue their annual programs. Although these programs differ to suit seasons in various environments, the organization of avian and mammalian populations demands so large a share of each individual's time that only limited periods can be utilized for feeding without endangering the structure of the population, which is as complex in the arctic as in milder climates.

HETEROOTHERMY IN HOMEOTHERMS

The Variable Insulation of Arctic Animals

The thick fur of arctic animals is obviously an insulator that protects them from excessive loss of heat (Scholander et al., 1950b). In fact fur is so effective an insulator that a man clothed in winter caribou (Rangifer tarandus) fur becomes overheated when he walks, and we do not yet know how animals with thick fur get rid of the heat generated by their long, swift running. A portal for the exit of surplus metabolic heat is provided by the thin covering of the limbs and noses. When active, these extremities become nearly as warm as the body, but at rest their skin cools. We found that the bare skin of the toe pads of arctic sled dogs and the hooves of caribou at rest might be near the freezing temperature. The large webbed feet of Alaskan Glaucous-winged Gulls (Larus hyperboreus) are nearly as cold as the icy water in which they swim (Irving and Krog, 1955). When we tried to measure the heat emitted to cold water from the extensive webbed foot of an Arctic Gull, the amount was so small that at first we regarded the results with suspicion (Scholander et al., 1950b) (Fig. 3).

Effective conservation of heat by cold skin is shown by the coldness of the entire surfaces of swine (Sus scrofa) in Alaskan winter weather (Irving, 1956). The value of their cool skin as an insulator is apparent in the practicability of raising hogs outdoors in Alaska, where our estimate indicated that they consumed about the same amount of food as in temperate climates (Irving, Peyton, and Monson, 1956).

An even more impressive indication of the insulating effectiveness of changing the temperature of bare skin was shown by the hair seals (Phoca vitulina and P. groenlandica) that J. S. Hart and I examined in winter at St. Andrews, N. B. (Irving and Hart, 1957). In ice water their skin was only a degree warmer than the surrounding water, and their metabolic production of heat was little greater than in warm air. Thus cooling of bare skin provides insulation against excessive loss of heat in arctic waters, which have the greatest capacity of any inhabited environment for removing heat. This thermal economy allows great numbers of seals, walrus, and narwhals to live throughout the year in the icy arctic seas.

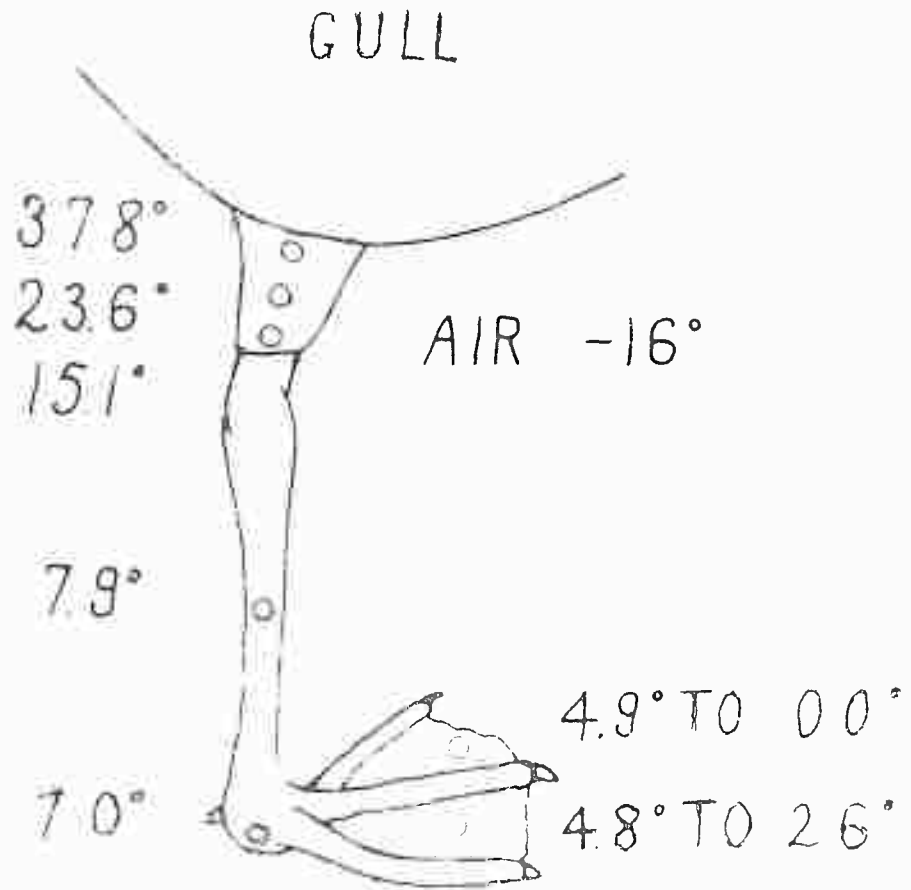

Figure 3. Topographic distribution of superficial temperatures in the leg of a gull (*Larus glaucescens*). Figure 9, page 361, "Temperature of Skin in the Arctic as a Regulator of Heat," JAP. 7(4):355-364. 1955.

HETEROTHERMY IN HOMEOTHERMS

It is an interesting indication of the general pattern of climatic adaptability of animals that while land animals shed fur in summer, northern harbor seals (*Phoca vitulina*) lose part of their physiological insulation in warm summer water at Woods Hole (Hart and Irving, 1959). As fur covered mammals vary the thickness of their coats to suit the season, seals reduce the effectiveness of their physiological insulation in warm weather. A number of examples illustrate that thermal adaptations of individuals are reduced as well as enhanced to suit seasonal climates.

Varying temperature of superficial tissues can thus efficiently adapt warm-blooded heat producing machines to operate economically in a variety of environments. In fact heat producing machines cannot work without thermal gradients. Until we examined arctic animals, however, I did not appreciate the extent of the swift changes in the thermal gradients of the tissues of warm-blooded animals. Now I find this variability in tissue temperature to be one of the most interesting characteristics of warm-blooded life, and I suspect that it is the primary insulator of the warm-blooded mechanism and that fur and feathers are secondary developments.

At the start of intense activity in cold weather bare skin may suddenly warm to nearly 40°C and then cool when rest is resumed. From measurements of thermal gradients extending for 6 to 8 cm beneath the skin surface in swine and seals, we have found that large masses of tissues are frequently involved in extensive thermal changes. In the temporal and topographic variations of superficial temperature, the warm-blooded animals differ fundamentally from the cold-blooded kinds. In warm-blooded forms only the center is relatively homeothermous, while the organism is heterothermous.

Variations With Temperature in Activities of Cold- and Warm-Blooded Animals

In summer on the tundra near the arctic coast of Alaska at Barrow, I noticed that when the sun shone intermittently through the clouds, the flies (*Grensia*) which I was pursuing escaped by flying. When the sun was covered by a cloud the flies became grounded, slow, crawling insects that I could easily catch. I inserted fine thermocouples in several of the flies and found that in shade they were

about 8°C and in sunshine they warmed to 12°C . The change of a few degrees converted the flies from slow, crawling to alert, flying organisms.

Not only do habits of living change critically in cold-blooded animals at certain temperatures, but many measurable physiological frequencies and velocities of their activities commonly double in warming 10°C . Aquatic cold-blooded animals do not usually survive the quick changes through which heterothermous tissues of northern warm-blooded animals rapidly and frequently pass, but some northern terrestrial insects can survive large and swift changes in temperature. If their activity changed continuously from 0°C to 40°C with the common Q_{10} of two, it would increase 16-fold, but the discontinuity in activity seen in the tundra flies shows that critical transitions in their cold-blooded activity occur at certain temperatures and drastically alter their manner of living.

The physiological systems of cold-blooded animals do not operate consistently over wide ranges of temperature, but the heterothermous superficial tissues of birds and mammals act in continuous coordination with the homeothermous centers so that each animal steadfastly remains one individual operating in its characteristic manner. This integrated action of heterothermous tissues may be the most informative distinction between warm- and cold-blooded life.

Our knowledge about processes in the heterothermous tissues of warm-blooded animals is too sparse to provide profitable speculation on how they are integrated in the continuous life of individual organisms, but I can add some examples of heterothermous operation in the adaptative reactions to cold of people living in northern climates.

Cooling of Hands and Feet of People Adapted to Cold

A few years ago I was fortunate in making the acquaintance of members of a sect accustomed to going with light clothing and bare feet in Alaska. Two of their members who were university students have helped us to understand some thermal reactions by their ability to manifest and describe their adaptation to cold (Irving, 1959). While

HETEROTHERMY IN HOMEOTHERMS

one student was sitting for 100 minutes in sparse clothing in a room at 0°C , a toe cooled, in 40 minutes, below 10°C and then warmed in two typical slow warming cycles. The toes of the other student cooled to 5°C at 65 minutes and were colder for the remainder of the 100 minute test period. During the tests the students studied for examinations and neither expressed or showed much disturbance by the cold. At 6°C the toes of one became insensitive to light touch, but both individuals remained sensitive and alert to small thermal changes when their toes were 8°C . One of them notified me that a certain toe was rewarming while its change was recorded from 10.0°C to 10.2°C and remarked upon similarly small cooling before the change was recorded. I suspect that their peripheral circulation is carefully monitored through alert sensations of temperature. Exposure to cold must train the conscious and unconscious observation of temperature for precise and vigorous reaction to meet temporal and topographic requirements (Fig. 4).

In the same condition and similar scant clothing, the toes of a young airman, who had been for two years an assistant in the Aero-medical Laboratory at Ladd Air Force Base, Alaska, cooled to 10°C in eight minutes and were very uncomfortable. At 14 minutes they were very painful, and his general discomfort became so great in 41 minutes that I asked him to give up for fear that his violent shivering would be injurious (Fig. 5).

I was at first unimpressed when one of the students told me that he had noticed sweating in his armpits while he was exposed to cold. When the adhesive tape holding thermocouples to a finger and toe were removed after his cold test, he pointed to droplets of sweat on rewarming fingers that had not yet reached 20°C . Airman Henson also looked for and showed me droplets of sweat on his fingers and toes as he was rewarming but still shivering. The paradoxical appearance of sweat on cold skin may give a clue to a common process of regulation in the simultaneous sweating and warming of cold tissues.

In their two years in Alaska the two students had developed the ability to work undisturbed while exposed to cold that we could not stand. Although they felt no pain in fingers and toes so cold as to be extremely painful for a person unpracticed in exposure, their

IRVING

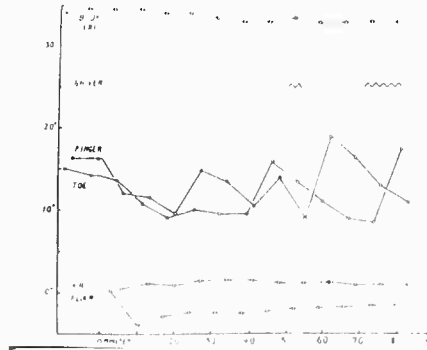

Figure 4. Temperature on skin of a young man accustomed to light clothing, bare feet and hands. Figure 1, "Human Adaptation to Cold." *Nature*. 185(4713): 572-574. 1960. Macmillan and Co., St. Martins Street, London, W. C. 2.



Figure 5. Temperature on skin of a young airman accustomed to regular military clothing. Figure 2, "Human Adaptation to Cold." *Nature*. 185(4713):572-574. 1960.

HETEROOTHERMY IN HOMEOTHERMS

thermal sensations were not numbed but remained alert. Their tolerance of cold appears to be an active accomplishment and not the result of insensitivity. I think it is right to say that they are adapted to cold, because their accurately developed reactions enable them to achieve the simplicity and comfort that they seek by wearing light clothing.

Reactions of Eskimos' Hands to Cooling

Since we are biologists we should look for adaptation as a function of populations and not look merely in the samples of young men whom we usually test. But it is hard enough to make observations on vigorous young men when they are exposed to cold, and experimental exposure to cold might appear to be cruel treatment of delicate women and frail children. Since 1947 I have often enjoyed the good company and been aided by the intelligent appreciation of arctic life of the vigorous Nunamiut Eskimos who live by hunting caribou in the mountains of arctic Alaska. While we were visiting with Simon Pan-eak and his pleasant family at Anaktuvuk Pass last March, Keith and Jo Ann Miller and I were able to examine the reactions of a sample of the population to cold. The men wear warm fur clothing while traveling, hunting, and working. Their small children set out to play in warm clothing, but in excited enjoyment of their strenuous sport they may play for hours after they have lost their mitts and after their disordered clothing becomes infiltrated with snow. It was no problem to get them to sit outside in air temperatures just below freezing with bare hands while we observed them from the comfort of the sod house (Figs. 6-11).

The hands of five Eskimo men and two young ladies remained a little warmer than those of three white men and two ladies. I think it is significant that the hands of the adult Eskimos showed marked rewarming reactions earlier than the white people, for we had noticed that when immersed in cold water the hands of Indian men at Old Crow began to rewarm earlier than the hands of the white men whom we tested there (Elsner, Nelms, and Irving, 1960). The tiny fingers of the tough little Eskimo boys cooled rapidly and very quickly began rewarming cycles which continued at short intervals as lively as their play. The boys' hands were often colder than 10° C.



Figure 6. Nunamiut Eskimo camp at Chandler Lake, Brooks Range, Alaska, November, 1947. Photo by Laurence Irving.



Figure 7. Nunamiut Frank Rulland, Simon Paneak, and Jesse Ahgook with P. F. Scholander, Chandler Lake, November, 1947. *Science*. 107(2777): Cover. Photo by Laurence Irving, 1515 Massachusetts Ave., NW Washington 5, D. C.



Figure 8. Nunamiut boys with Jo Ann Miller at Anaktuyuk Pass, March, 1960. Photo by Keith Miller.

HETEROTHEPMY IN HOMEOTHERMS

Figure 9. Nunamiut boy at play, Anaktuvuk Pass, March, 1960. Photo by Keith Miller.



Figure 10. Nunamiut boy after losing gloves at play, Anaktuvuk Pass, March, 1960. Photo by Keith Miller.

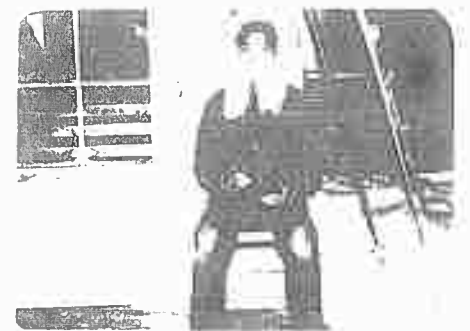

Figure 11. William Tobuk with hands exposed for cold test, Bettles, March, 1960. Photo by Keith Miller.

IRVING

Another important difference was in the expression of pain. Most white people find fingers around 10°C painful, and our white subjects spoke very plainly about the cold as disturbingly painful. The two Eskimo young ladies said their fingers pained a little. The Eskimo men and boys did not openly express or demonstrate pain or appear anxious to terminate the test as did the white people; but on questioning two of the nine said their fingers became a little painful. Most of the Eskimos said, however, that their hands became very cold. Keith Miller is now analysing records obtained at the Arctic Research Laboratory, Barrow, during exposure of hands to just below freezing air in 12 Eskimo men, 4 women, 15 children, and 14 white men, 7 of whom were accustomed to work outdoors. His records substantiate with details the general impressions gained from Eskimos at Anaktuvuk Pass.

With fingers so cold that the pain would have disturbed us the Eskimos seemed undisturbed. But the lively thermal reactions of the Eskimo boys showed that their vasomotor regulation was sensitive. After they had been happily and noisily at play for several hours their hands were so cold as to appear beyond our safe tolerance. Although they do not appear to depend upon warning by pain they cannot be insensitive to cold, for when the children's fingers verge upon dangerous cold conscious and unconscious attention for re-warming must be especially accurately controlled in order to protect the little fingers with their relatively feeble supply of heat.

Eskimos cannot safely expose their hands to severe arctic cold longer than a few minutes; therefore this adaptation of part of the surface of Eskimos is small in comparison with the degree and extent of the adaptation of the extremities of arctic animals. But even this small adaptation extends their ability to work sufficiently to allow for many essential acts which can only be performed with hands unencumbered by mitts. That frostbite is so rare among Eskimos is the result of their keen conscious and unconscious appreciation for the limits of time and intensity of cooling that they can endure.

Observations on the Integration of Heterothermous Tissues

For individual existence to be coherent it must be continuously related to information about its internal condition and external circumstances. Apparently an individual must always appreciate certain

HETEROOTHERMY IN HOMEOTHERMS

physical dimensions in absolute terms. For example, the force required to move the mass of a leg does not change with temperature, but physiological processes involved in sensory detection of physical forces do change with temperature. Mammals and birds appear to differ from the cold-blooded animal, however, in the large inconstancy of temperature in superficial tissues and in the integration of individuality in this heterothermous condition.

After seeing that the fingers of people adapted to cold were usefully coordinated when very cold, I have been trying to find a pertinent measure for their sensitivity. It seemed to me that terrestrial animals would need constant appreciation for force and mass in order to move. Stimulation by impact is a convenient test because mass and the distance through which it falls can easily be varied and measured.

Cabbage seeds selected for uniform weight, about a miligram, were found detectable after falling about 20 mm onto the ball of the warm mid-finger. The impact of a seed of double the size was noticeable after falling 10 mm, or the threshold for stimulation varied about as the kinetic energy of the impact. Other parts of the skin differed in sensitivity, and as the skin was cooled, a heavier weight or longer fall was required for the impact to be detectable.

It was easier to discharge mercury droplets weighing from 1 to 3 mg by Scholander's micrometer burette which, with a plunger 1.59 mm in diameter, measured volumetrically the drop discharged through a hypodermic needle to within a few hundredths of a milligram. The kinetic energy of the impact on the ball of my middle finger that I could just detect increased rather regularly about eight times as my finger was cooled from 35° C to 20° C (Fig. 12).

Keith Miller is now using small steel ball bearings for weights and finding that when measured as kinetic energy of detectable impact the threshold stimulus increases regularly in a trained subject as the skin cools. Individuals differ in sensitivity and in the rate of diminishing sensitivity with cold. We have not discovered whether this measure of sensitivity of cold fingers will distinguish differences in the people accustomed to cold whom we regard as adapted.

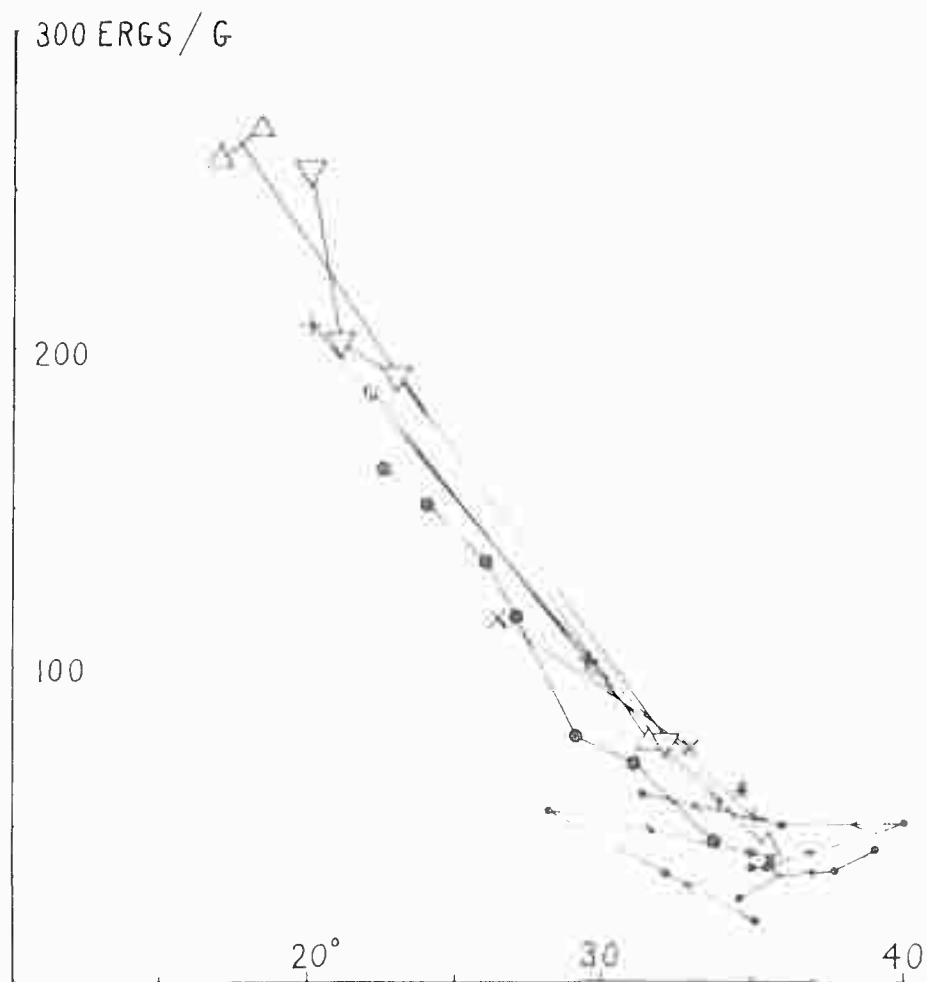

Figure 12. Change in threshold with temperature for detection of impact on the ball of one individual's finger. Abscissa: temperature of skin of fingertip. Ordinate: impact of falling droplet of mercury. Unpublished.

HETEROTHERMY IN HOMEOTHERMS

The report of sensation involves complex neural mechanisms which we cannot analyze physiologically. Since only part of the hand or of a finger is cooled and we cannot control effectively the amount of tissue cooled, we suspect that the regular thresholds observed in day after day tests indicate that cooling of the hand affects the local peripheral agents of sensation. But we are still only measuring a threshold and not the sensation that is involved in our estimation of the physical dimensions of stimulation. It is nevertheless interesting to consider this test an illustration of the integration of heterothermous tissues in an individual organism. Certain characteristics of the external world must be appreciated in constant dimensions, and yet the signals for those dimensions are submitted through peripheral transducers that change characteristics as the tissues which contain them warm and cool.

In comparison with the natural adaptation of animals to cold, the best physiological adaptation developed in people is only of small magnitude, and cultivated human habits and economy provide the main protection from cold. Some people resident in cold climates are motivated to utilize to the utmost their small physiological adaptability to cold. They find it worthwhile to practice exposure that seems very unpleasant for us who are accustomed to sheltered urban life. We face the test of cold with anxiety and respond in the irregular manner that characterizes untrained physiological reactions.

Power and equipment from foreign sources are used to relieve soldiers and transient workers in the north from adaptation to its cold climates. In each successive war in history power and technology have improved the protection of armies from cold and enabled them to live and move effectively in any climate and on any terrain. In spite of improving protection from the weather it is surprising that in every war winter cold blocks operations in the field and continues to be a major cause of injury. The reason lies in dependence upon power susceptible to accidental disruption. Military tactics aim to damage the enemy's vulnerable heating system or to lead him into a position where its effectiveness diminishes. Then troops accustomed to sheltering warmth are immobilized by the protection that has left them inexperienced in cold, while those less dependent upon artificial warmth may retain a small but decisive ability to maneuver.

IRVING

The necessity for independence requires Eskimo populations to utilize their adaptability in winter. Even the limited human physiological adaptation is important in the natural economy of arctic life, and it is interesting to see how this adaptation is used by the Eskimo children for enjoyment of their environment. If it were considered worthwhile we could doubtless dispense with some of the expensive protection from cold that complicates living and restricts our experience. Whether or not physiological adaptation to cold is economical, I hope that some people will continue to practice ways leading to adaptation so that by their reactions we can gain insight into the interesting physiological components that appear in human adaptation to cold.

HETEROTHERMY IN HOMEOTHERMS

Subject	Age	Air (°C)	Rewarming (Minute)	Pain (Minute)	Body
<u>White:</u>					
LJ	65	- 6	9	10 moderate	Warm
JLA	39	-11	12	8 severe	Warm
NG	22	-15	10	17 moderate	Warm
AB	40	- 7	17	14 moderate	Warm
JAM	26	- 6	6	3 moderate	Warm
			<u>10</u>		
<u>Eskimo:</u>					
JR	31	- 9	5	---	Warm
CH	45	-14	11	---	Warm
			<u>8</u>		
RN	36	-12	10	---	Shivering
Robt. P	23	- 5	4	---	Shivering
Ray P	20	- 4	8	---	Shivering
MP	19	- 9	5	17 moderate	Warm
RM	20	- 8	7	3, 21 moderate	Shivering
			<u>7</u>		
HH	11	-18	1	---	Warm
GP	11	-16	0	---	Warm
WI	12	-12	1	---	Shivering
Roos. P	14	-16	3	---	Warm
			<u>1</u>		

Table 1.

IRVING

LITERATURE CITED

1. Elsner, R., J. D. Nelms, and L. Irving. 1960. Circulation of heat to the hands of arctic Indians. *J. Appl. Physiol.* 15(4):662-666.
2. Hart, J. S. and L. Irving. 1959. The energetics of harbor seals in air and in water with special consideration of seasonal changes. *Can. J. Zool.* 37:447-457.
3. Irving, L. 1956. Physiological insulation of swine as bare-skinned mammals. *J. Appl. Physiol.* 9(3):414-420.
4. Irving, L. 1959. Human adaptation to cold. *Nature* 185(4713):572-574.
5. Irving, L. and J. S. Hart. 1957. The metabolism and insulation of seals as bare-skinned mammals in cold water. *Can. J. Zool.* 35:497-511.
6. Irving, L. and John Krog. 1954. Body temperatures of arctic and subarctic birds and mammals. *J. Appl. Physiol.* 6(11):667-680.
7. Irving, L. 1955. Temperature of skin in the Arctic as a regulator of heat. *J. Appl. Physiol.* 7:355-364.
8. Irving, L., L. Peyton, and M. Monson. 1956. Metabolism and insulation of swine as bare-skinned mammals. *J. Appl. Physiol.* 9(3):421-426.
9. Lavoisier, A. L. 1777. Experiences sur la respiration des animaux et sur les changements qui arrivent a l'air en passant par leur poumon. *Mem. Acad. Sci. Paris*, 1777, p. 185. (*Oeuvres de Lavoisier*, vol. 2, p. 174).

HETEROOTHERMY IN HOMEOTHERMS

10. Scholander, P. F., R. Hock, V. Walters, and L. Irving. 1950a. Adaptations to cold in arctic and tropical mammals and birds in relation to body temperature, insulation, and basal metabolic rate. *Biol. Bull.* 99(2):259-271.
11. Scholander, P. F., R. Hock, V. Walters, and L. Irving. 1950b. Body insulation of some arctic and tropical mammals and birds. *Biol. Bull.* 99(2):225-236.
12. Tyndall, J. 1898. *Fragments of Science*, Vol. 1, p. 428, New York.
13. U. S. Dept. of Commerce. 1959. *Climatological data, Alaska*. Asheville.

IRVING

DISCUSSION

MILLER: As Dr. Irving stated, Figure 13 summarizes one aspect of a study made at Barrow late last winter involving Eskimo and white subjects. Several of the whites were normally cold-exposed to a considerable extent, while others received little if any cold exposure. In Figure 13 you see finger cooling rates of Eskimo girls, aged about 11 to 12, Eskimo boys of the same age, outdoor or cold-exposed whites, and indoor, non-cold-exposed whites and Eskimo adults with varying degrees of cold exposure. The lines connect points representing cooling rates of five different fingers averaged for the individuals in each group. Cooling rates were calculated from temperature determinations made at 30-second intervals during an initial five-minute cooling period. There appears to be a definite relationship between hand volume and the initial five-minute cooling rate. The smaller fingers of the children show a more rapid initial cooling rate than the adult fingers. Ignoring the group of indoor or non-cold-accustomed whites for the moment, it may be seen that the relationship between initial cooling rate and hand volume among the various groups is approximately linear, the cooling rate being decreased with increasing hand volume. The most striking feature exhibited by the slide is the fact that the indoor non-cold-exposed white group exhibits an anomalously high cooling rate in comparison with adult Eskimos and cold-exposed whites. This more rapid cooling rate is most prominent in the little finger, although it is exhibited to a noticeable degree even by the thumb. Another point of interest is the degree of variation among different fingers within each subject group. Variation among cooling rates of different fingers is greatest in the group with the smallest hand size, the Eskimo girls, and decreases steadily with increasing hand volume, again with the exception of the indoor whites. The degree of variation within the whites not accustomed to cold was almost identical to that of the Eskimo boys. The fact that white men not accustomed to cold exhibited a finger cooling response significantly different from that of Eskimo men, despite the similarity of average hand volumes, would seem to indicate that a difference in preparatory response to hand cooling is present between the two groups. Whether this difference, if real, is due entirely

HETEROOTHERMY IN HOMEOTHERMS

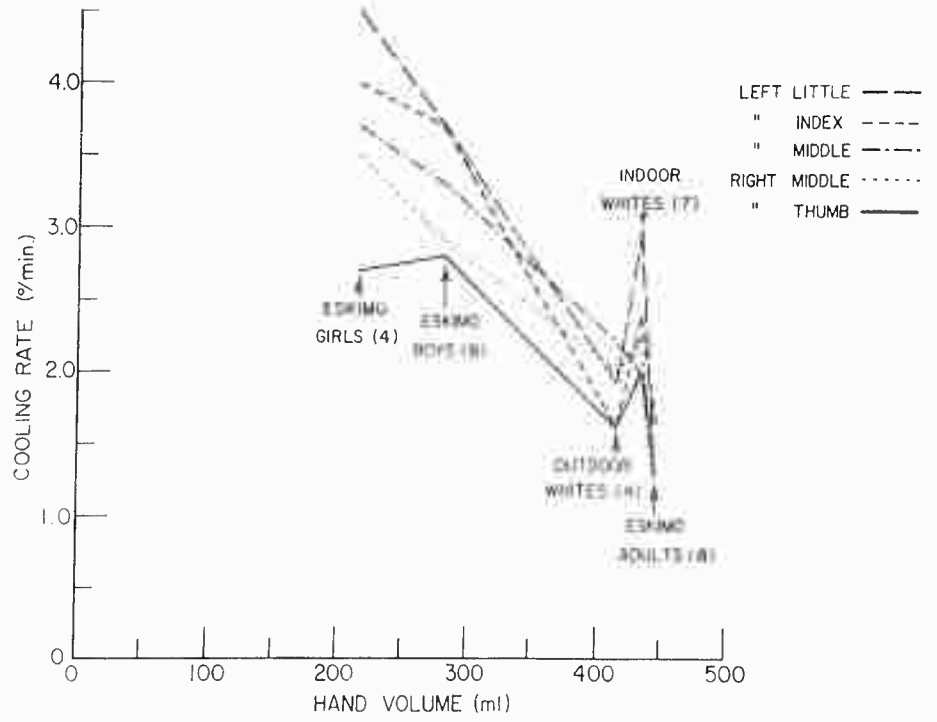

Figure 13. Initial (5 minute) cooling rates of various fingers of Eskimos and Whites plotted as a function of average hand volume.

IRVING

to group differences in regard to previous cold experience, I would not wish to say at this time. The exposure temperatures were from -5°C and -10°C .

EAGAN: Is it possible that whites who worked indoors could afford more expensive clothing?

MILLER: No, not unless you want to insult all the members of the Arctic Research Lab.

HART: Were the hands exposed in open air?

MILLER: Yes.

MORRISON: Is the larger hand volume characteristic of the Eskimos?

MILLER: No, it is not significantly larger. There is just a very slight difference.

MORRISON: It is 10% which would seem to be an appreciable amount.

MILLER: But it does not appear to be statistically important. It is a relatively small group.

HUDSON: Are there any changes in blood flow?

MILLER: I did not make any determinations of blood flow, but other people have correlated blood flow changes with adaptation in Eskimos by cooling them in water. This is, more or less, a complimentary study, using air cooling.

EAGAN: I would like to ask Dr. Irving one thing; your concept of peripheral heterothermy, I believe, presupposes an improvement in sensitivity to all the general factors in the environment at the same or at a lower temperature. Does this also include the ability to cool more and yet maintain sensitivity to environment?

HETEROTHERMY IN HOMEOTHERMS

IRVING: Well, there certainly must be improved sensitivity; that would be the conclusion from the fact that they appear better able to monitor what is going on outside. That is, they are more observant of minor temperature changes in exposed skin areas such as the face and fingers. This is not a reduction in sensitivity or simply hardness. Rather, along with the suppression of pain or the suppression of the impression of pain, there is apparently a more refined observation of the local temperature condition of the skin. As yet, we have not successfully demonstrated that sensitivity is retained at a better level in the cold adapted skin than in the warm adapted skin. So far we have only used these sensory tests with people that were unadapted to cold. There are other tests that indicate that the temperature sensitivity is retained better in the cold skin after the people have been accustomed to exposure.

EAGAN: From the figures you have given on Eskimos, there is a suggestion that their adaptation is an ability to maintain higher peripheral temperatures, so that we cannot say that this is in any way related to peripheral heterothermy as being an economical type of adaptation.

IRVING: Well, you have to qualify the statement and say which Eskimos you are talking about. As Mr. Miller has shown, there is a real difference between men and children, and yet they are all normal components of the population. In addition, he also observed that the skin of the Eskimo children did cool more rapidly and to a lower temperature during the period of exposure than was true of any of the adults.

EAGAN: Children do seem to withstand very low hand temperatures even here in Fort Wainwright.

IRVING: I do not know whether it is true of all children or not. We do not dare to ask parents to lend us their children for experiment, but we have no compunction about asking the Eskimo children to cooperate. They enjoy it.

EAGAN: Glasser's work with habituation or repeated presentation of an extreme cold stimulus shows that there is a change in

IRVING

the way that the central nervous system handles its appreciation of this stimulus. Thus, after a series of exposures the organism appears to gain confidence in itself. There is every evidence that the discharge of cold receptors proceeds at the same rate, but the change in the sensation of cold is localized in the sensory cortex; that is, there is an habituation to cold. This can be suppressed by anxiety. I would think that possibly the central habituation may often be of much greater importance than peripheral heterothermy as a mechanism of cold adaptation.

IRVING: I would like to know if anyone has ever demonstrated that the discharge of the peripheral sensory endings is maintained during cold exposure.

EAGAN: We only have indirect evidence of this. Dr. Hensel has not done it, but I believe Glasser put on a demonstration before the Physiological Society. He had a subject who was accustomed to immersing one finger in ice water six times per day and who no longer gave any evidence of a pressor response or of a cardiac acceleration response to this measurement. However, when the subject was brought up before the group at the physiological meeting, he did show the pressor response and the tachycardia. He has made other indirect observations on experiments in which they have induced anxiety in the subject, causing him to show this physiological correlate of pain sensation. Also, he had an argument which involved the use of tranquilizer drugs, and from all of this he thought that the simplest explanation was that the discharge of the peripheral receptors is unchanged.

IRVING: Well, I cannot discount the operation of the central part of the system in habituation, as distinct from peripheral adaptation. I would say that adaptation likely involves change in the physiological behavior of peripheral organs or tissue. I think there is sure to be some alteration there; for example, the changes in some of the nerves of the poikilotherms result in the blocking of their conduction and excitability at a lower temperature after they have become used to that temperature. That is the sort of thing I am confidently looking for since we observed that the peripheral nerves of cold adapted sea gulls conducted at lower temperatures than when warm adapted.

HETEROOTHERMY IN HOMEOTHERMS

PROSSER: It might be that these other more complex integrated functions are superimposed upon peripheral change. I do not think one would expect a single line of defense here, but a double line of defense.

IRVING: I do not see how the nervous system can possibly work, anyway. What I mean is, how can it maintain the constancy of appreciation for external conditions through a thermo-labile system which changes so grossly in many of its velocity and frequency functions? A gram remains a gram, and that is that. A millimeter remains a millimeter and that is that. If the universe changed dimensions as it changed temperature, we would gonuts; we would not be here.

EAGAN: There was an experiment we did in which four subjects exposed one hand in a cold box for 12 hours per day for ten consecutive days, the finger temperatures being maintained between 10°C and 15°C during the period of exposure. The latter was accomplished by having the subject withdraw his finger slightly as the finger temperature increased or decreased towards 10°C or insert it farther into the cold box as it increased towards 15°C . The subjects complained quite a bit at first, especially as it was getting toward the 10°C side of things. As the days passed, their cold tolerance was greatly increased and they would even go to sleep with finger temperature at 10°C , a temperature which was too painful in the beginning to even consider any sleep. Interestingly enough, when they did go to sleep, the finger temperatures invariably rose; we had to awaken them so that they could shove their hands into the cold box a little further. In general, I feel that this experiment nicely demonstrates a decrease in the discomfort due to cold as a result of continuous exposure.

IRVING: I think that is very important. Even though we say "pain" is not physiologically definable as yet, it is nevertheless a very important fact. Pain is pretty real, especially pain from cold. A person unaccustomed to cold just cannot conceal it. I think the mechanisms responsible for this habituation present a most interesting question. As a result of habituation there is repression of the sense of pain, but we do not know whether there is any change in

IRVING

the rate, the velocity, the thresholds, or the temperature of cold block for the actual nerve tissues in the periphery. There must be some way to get at this question.

PROSSER: What would be the best animal to use? Hensel's work has been done almost exclusively with cats.

IRVING: People are pretty good.

PROSSER: But you cannot go in and record the nerve impulses. I want an animal in which you can go in and record the nerve impulses.

IRVING: I would take a bird like a gull, because for one thing they are not pleasing animals; you have no sympathy for them at all. By just putting blindfolds over their heads you can pretty well immobilize them, and when so quieted you can readily expose their long bare legs to cold.

EAGAN: I think a lot could be done by using Irving's and Miller's ball-bearing test on fingers. When you use bilateral comparisons you can so simply compare the adapted side with the controlled side.

PROSSER: Is this sensory adaptation which may be occurring due to the temperature per se, or might it be due to changes in oxygen supply?

IRVING: Temperature, per se, must be a factor in this habituation. However, since cold does reduce the circulation, then oxygen supply is also a probable factor.

ADAMS: You can superimpose the effects of anxiety, induced either by emotional stress or by pain on the cold induced vasodilation response. In some subjects where we have measured cold induced vasodilation responses, we find that we can prolong the period of the peripheral vasoconstriction (with the finger surface temperature at 0° C) up to 25 minutes in the ice bath by superimposing the effects of anxiety on the basic pattern of the response.

HETEROTHERMY IN HOMEOTHERMS

In these studies we found finger temperatures were about 33°C when the subject was supine at a room temperature of about 20°C . After stable measurements were attained at room temperature, the finger was immersed into a stirred ice bath. At this point, of course, a typical "Lewis response" occurs; that is, a rapid cooling to approximately the temperature of the bath, followed by a period of spontaneous rewarming to about 10°C to 12°C . I think that this is an almost classical response and anyone can reproduce the experiment using similar test conditions. This is the type of response that we find in all of the subjects in non-anxiety states. In superimposing the effects of anxiety, however, we can change this pattern to one where the cooling phase is prolonged to 25 minutes after the initial immersion of the finger into the ice bath. This is to be contrasted to the "unstressed" subject, where the spontaneous vasodilation normally occurs in about 7 minutes. This, I think, would probably indicate that there is a functional integrity of at least the efferent nervous components in the peripheral portion of the finger at these temperatures. Incidentally, the temperature that I am discussing is, of course, the temperature at the thermocouple taped to the surface of the finger. It indicates very little, if anything, about temperatures deeper in the finger where one may expect to find the sensory endings and where you may also expect some peripheral vascular changes to come about with mild degrees of adaptation or cold acclimatization.

We became interested in this phenomenon as a possible test site for induced variations in peripheral vascular responses with local chronic cold exposure in the same individual. The conditioning phase in our series of experiments consisted of immersing the same portion of the right index finger in a stirred ice bath for 20 minutes each time for one month; different groups of subjects underwent two, three, or four such exposures each day. In the group of subjects that showed the greatest difference in response to the finger immersion in stirred ice water, we found the finger temperatures cooled to only 10°C in the bath, compared to 0°C in the control experiments. The first thing that we saw was an earlier initiation of the rewarming phase after about one week of cold conditioning. We also carried out digital calorimetric measurements when the finger was maximally vasodilated in the bath and found a statistically

significant difference between the heat dissipation to our digital calorimeter of the control and locally cold conditioned digits.

There is a possibility that this vasodilation, or relatively reduced vasoconstriction, could be due to the destruction of the components or functions in the finger that would allow for maximal vasoconstriction during immersion in the ice bath. That is, the vasodilation we see developing in the locally cold conditioned finger may be due to a destruction of vasoconstriction potential. However, using anxiety again as a variable, we found that with our subjects, all of whom were either medical or graduate students and in whom it is very easy to induce anxiety, the induction of anxiety by verbal suggestion at any point in the phase of vasodilation brought the finger immediately to 0° C, with a cooling pattern similar to the initial vasoconstriction seen in the control experiments. I do not feel, therefore, that the cold conditioned fingers have lost the ability to vasoconstrict maximally. The altered CIVD patterns appear to result from an adjustment in peripheral circulatory control rather than a simple destruction of function.

EAGAN: I would like to point out that you have to be very careful in using thermometry to deduce what is happening in the blood vessels, but you cannot fool a calorimeter if you use exactly balanced systems in testing the two fingers. In similar experiments of recurrent finger cold exposure we have used plethysmography, thermometry, and calorimetry concurrently, and we do not see any of these CIVD differences you report.

ADAMS: I think such calorimeter data are quite acceptable for showing an increase in digital blood flow. It is possible, however, that one could have a change in circulation or circulatory mechanisms, perhaps in an increased blood flow deep in the finger, that would not be reflected in surface temperatures.

EAGAN: How can you fool a plethysmograph? Calorimetry will measure the average response over 30 minutes, if that is the length of immersion. With thermometry you get something intermediate in capability for detecting vascular change. It is slightly more sensitive than calorimetry, but nevertheless, in vasoconstricted tissue, because of the thermal capacity of the tissue and

HETEROTHERMY IN HOMEOTHERMS

because of its low thermal conductivity, you will have a considerable delay in detection of vasodilation. We have used the mercury strain gauge, which you can place on the finger and which makes plethysmographic measurements by using either the volume pulse or the measurement of blood flow but does not interfere with the exposure of the finger to the environment. And here we have a very sensitive measure of the most subtle changes in vascular responses. Yet, despite this we have failed to detect any evidence in favor of a local adaptation to cold insofar as the CIVD response is concerned.

FOLK: I would like to ask Dr. Johansen to comment again on his work with huskies. As I understand it they showed high body temperatures after being on the trail. If you are talking about some other animal we might find evidence of cross-acclimatization, but if I understand it correctly, the husky does not show cold acclimatization. Is it possible that there might be heat acclimatization?

JOHANSEN: My studies on the exercising of huskies were essentially not complete in the sense that I studied all the factors involved in thermobalance. I did not measure superficial temperatures, for example. I did find, however, that training lowers to some extent the great increase in temperature that is seen after intense exercise. I do not know if this will hold up statistically, but I do think that the effector systems for heat loss in the husky, the wolf, the fox, and a number of other semi-large arctic mammals are not effective enough to give a steady state thermal balance at high levels of exercise. There seems to be an inevitable accumulation of heat.*

MORRISON: What was the ambient temperature when you were running those huskies?

JOHANSEN: From 50°C to 40°C below zero.

MORRISON: We ran some similar studies with huskies, and in two sets of experiments of about an hour each we did not get any

*Rapid or slow, this heat accumulation is probably related to the whole problem of fatigue.

IRVING

such increase in body temperature. These measurements were made during a normal regime with the team pulling a loaded sled and with three to five minute rest breaks every 15 minutes.

IRVING: These were trained?

JOHANSEN: Yes, eventually. They were not trained at the start of the season, of course, but they were gradually trained during the course of the winter.

EVONUK: What was your environmental temperature, Dr. Morrison?

MORRISON: It was in February or March; the temperature was near 0° C.

JOHANSEN: I have done similar studies on smaller, well-furred arctic mammals, like the muskrat, and if I dispense with their avenues for heat loss, for instance by occluding the tail as a heat exchanger, then they show a very high body temperature. In other words, heat loss through the feet and the nose and panting is not enough to keep them at a normal body temperature.

ADAMS: There were also some data on beagles* showing that voluntary exercise terminates at a particular level which seems to be determined by the body temperature. The rate of body heating is decreased with training. Untrained dogs will have a more rapid rate of increase in body temperature when exercised on a treadmill, whereas trained dogs will show a slower rate and will reach a particular rectal temperature in a much longer time.

JOHANSEN: I can tell you that just harnessing up a dog team makes them quite excited; it is enough to increase their body temperature more than one degree.

HANNON: Dr. Durrer and I have done a lot of work related to this problem of insulation and metabolism of well-furred, well-insulated dogs versus those that are not so well insulated. Thus,

*Young, D. R., et al. 1959. J. Appl. Physiol. 14:839.

HETEROTHERMY IN HOMEOTHERMS

the daily caloric intake of huskies was measured throughout the entire year. In addition, the daily caloric intake of beagles was measured over a period extending from late winter to summer to early winter again. Contrary to what you might suspect from reports in the literature, there is a marked seasonal difference in caloric intake in both groups of dogs--very high rate in winter and low rate in summer. In the husky this occurred despite a large increase in winter insulation. The difference between the amount of calories they took in in summer and winter was in the neighborhood of 60% in the husky and 70% in the beagle.

The data of Scholander and Irving's group at Barrow* indicate that a few arctic animals show no effect on metabolism through a temperature range. We saw a similar thing in the caloric intake of huskies during midwinter, when the environmental temperature made a sudden drop from -7°C to -44°C . This temperature change had no effect on caloric intake. We did not take a look at this type of thing in the beagles, but the beagles between winter and summer showed changes very similar to those seen in the huskies from the standpoint of caloric intake--a little greater, but not appreciably so. As a result of these observations on caloric intake, we are coming to the conclusion that in these animals the basic response appears to be metabolic and the insulative change probably serves to increase their capacity to tolerate even lower environmental temperatures.

In the husky it is interesting that early in the winter, in November in particular, his caloric intake is somewhat above that seen later in the winter. For example, it may go up to 70% above the summer level and then drop back down to a plateau that is maintained for the remainder of the midwinter. This would suggest that as he picks up his winter insulation he is able to compensate somewhat for the increased caloric demand of the environment. We did not carry the beagles far enough into the winter to see if there was a similar sort of reduction in caloric intake. However, no gross changes in fur insulation were apparent.

*Scholander, P. F., et al. 1950. Biol. Bull. 99:259.

IRVING

HART: You have an increase in food intake of 50% to 60%?

HANNON: This is average daily intake on five huskies.

HART: I do not think that you can conclude that this necessarily represents metabolic temperature regulation. How well did you control activity, sledding and various things?

HANNON: These dogs were tied with six-foot chains. They were only released from these chains a few times, in both summer and winter, to be brought into the laboratory for blood sugar determinations. Furthermore, in the winter the body weight declined, and in the summer it increased, thus suggesting an inability to precisely match the caloric intake to the energy demands of the environment. In other words, in the summer they were eating too much and in the winter too little to maintain a constant body weight from season to season.

HART: Is not 60% a large increase in food intake for a well-insulated animal?

HANNON: It would seem so, yes.

MORRISON: Are they rather limited in their activity in the summer?

HANNON: Grossly, the animals appeared to be most active in the summer and the least active during periods of extreme winter cold. Whether this produced a significant seasonal difference is unknown. It is my guess, however, that they may be more active in summer, because there are more people around them.

DURRER: It is interesting to note that in temperatures of -35°C or -40°C the activity is quite reduced. For example, they are even reluctant to get up and eat and are not as apt to rise in the presence of people at these extreme winter temperatures as they are in summer or in the warmer winter temperatures.

JOHANSEN: One factor that has not been mentioned is the

HETEROTHERMY IN HOMEOTHERMS

availability of food to the animal. It is extraordinary when an animal has more food than he can eat everyday. This is certainly not what you would expect arctic mammals to be confronted with in his natural environment.

HANNON: That is true, but if we had attempted to control caloric intake we would have biased our results by the mere fact that you are controlling the amount of food available.

IRVING: He is thinking that the dog chooses to eat more when excess food is available. Why he chooses to eat is a different thing.

MORRISON: I might add that our appetite in cold weather exceeds the thermoregulatory needs of the body.

HANNON: After the first two or three weeks of over-eating they reduced their intake and it remained fairly constant from day to day. However, when you consider these daily intakes over a period of months the differences between the seasons are significant, and there is a significant correlation between temperature and food consumption.

HART: Have you done this over the whole winter and summer?

HANNON: On the huskies, we have it starting with November of one year and continuing through November of the following year.

MORRISON: How about the beagles?

HANNON: The reason we used beagles is interesting in itself. We started these feeding experiments on huskies on the first of October and commenced our measurements of food intake on the first of November. As I mentioned earlier, there was a decline in food intake between November and the later portions of the winter. This did not seem quite right; so in midwinter we decided we had better look at dogs that were not so well-insulated as the huskies. Beagles seemed to offer a good choice. They were purchased in California and brought to Alaska, where they were housed indoors for four weeks. During this period they were allowed two weeks to adapt to the same diet as the huskies and two weeks

IRVING

during which control measurements were made in the laboratory. They were then subjected to outdoor exposure. When we first put them out in the cold the temperature was about 0° F. At first they could not tolerate this cold on their feet and would howl, roll on their backs and put their feet in the air. During subsequent exposures of gradually increasing duration they evidenced cold injury, particularly on the feet, ears and mouth. However, within a period of two or three weeks these injuries began to disappear and they were eventually able to tolerate temperatures as low as -30° C for a full 24 hours with no apparent ill-effects. Such continuous exposure was continued through the remainder of the winter, the summer and into the early months of the following winter, when the experiment was terminated.

MORRISON: Were they eating meat or dog chow?

HANNON: The diet was fairly high in protein; it was a mixture of dry dog food, powdered milk, and fish meal.

WEST: Did you find any difference in efficiency?

HANNON: Do you mean work efficiency?

WEST: No, efficiency of food assimilation; that is, the utilization of the energy that you gave them. Did you get the caloric value of feces, for example, to see if they were using all this food that you were feeding them?

HANNON: No, we did not.

KLEIBER: I may have an answer to that, not for dogs but for baby chicks. There we found a very consistent correlation between food intake and temperature; namely, as we decreased the temperature from 100° F to 95° F to 80° F to 70° F, there was a consistent increase in food intake. There was also a decrease in digestibility.

WEST: We found the same decline in efficiency with wild birds. I wonder if this is a part of the explanation for this increase in food intake.

HETEROTHERMY IN HOMEOTHERMS

KLEIBER: We measured that and found that there is a definite increase in caloric output.

HANNON: Well, the magnitude of the change in the beagles, at least, between this summer and winter is very similar to what you see in rats going into a 5° C cold room, thus suggesting a similar caloric demand by the environment. In the cold, rats certainly exhibit a high rate of heat production, but as far as I know the efficiency of food utilization has never been measured.

IRVING: To get back to the remarkably high body temperature that Dr. Johansen spoke about, I would like to inquire whether there are reports of domesticated animals having reached similar high temperatures?

KLEIBER: Yes, Kibler and Brody* recorded rectal temperatures in Holstein cows as high as 108° F (42° C). Generally cows are in bad shape in a hot environment.

FOLK: I might make another comment on continuous feeding of dogs, since apparently not too many people have heard about it, but some of the big kennels have been doing that for several generations. Sometimes, in experiments like those you do with white rats, you want to have continuous food there. You do not want a perturbation. If they have had food in front of them when they are quite young they do not overeat. Occasionally there is one dog you will need to eliminate because it does overeat, but they are rather quick to learn to take just enough out of a feeder.

HANNON: Our dogs in the study were two to four years old. Thus, they were adults. Food was placed in front of them and left for a period of one-half hour. But, as I mentioned earlier, they would eat a little bit too much in the summer time and too little in the winter time insofar as the maintenance of a constant body weight was concerned.

MORRISON: I wonder if the specific dynamic action of the food

*Kibler, H. H. and S. Brody, 1955. Influence of humidity on heat exchange and body temperature regulation in Jersey, Holstein, Brahman and Brown Swiss cattle. Univ. of Missouri Res. Bull. 522:111.

IRVING

would produce enough heat to make them uncomfortable in the summer and if this could modify their intake. Such an effect should not bother them in winter.

HANNON: We do not know, except that in the winter they have heavy insulation. In the summer they do not.

MORRISON: They can lie in the snow and dissipate more heat.

HANNON: I believe Dr. Irving has made some measurements on the amount of heat that huskies dissipate to the snow when they are lying down?

MORRISON: Well, how much they can dissipate and how much they do dissipate depends on whether they are in a heat dissipation "posture" or not.

HANNON: If dogs are lying in the snow dissipating very much heat, a melting of the snow should be evident. This does not seem to occur.

IRVING: There is no melting. John Krog and I measured the temperature under dogs by putting a grid of thermocouples under the place where they slept. We found that the temperature at the surface was not above freezing, and the snow did not melt although it did become compressed. If the snow had melted, the fur would have froze to the snow, and you never see any fur frozen in a place where a normal animal has been bedded down in the snow.

JOHANSEN: If I may switch back to the high temperatures now, I think that we really need a lot more measurements. The only really detailed study available is Asmussen and Nielsen's study of athletes, which showed a rectal temperature of 41°C after long track running. It may be surprising to you, but it is not to me, that the husky, with its tremendous insulation, gets such a great increase in temperature.

IRVING: Have you obtained any evidence that he really develops a better faculty for supporting a high body temperature?

HETEROOTHERMY IN HOMEOTHERMS

JOHANSEN: No.

IRVING: I think this would be a very valuable thing to determine, especially when sled-dog running is so well cultivated here; you might even use such information to get good teams of dogs.

JOHANSEN: Of course I would like to measure running caribou and, when I get back to Norway, the reindeer, which is domesticated and used for transportation.

HART: I would like to mention this in connection that even in the small mammals such as mice and rats body temperatures up to 40°C or 41°C may be obtained during exercise of 20 or 30 minutes duration. It is commonly possible to do this in a relatively warm environmental temperature. However, in a cool environment, the body temperature may not rise at all.

JOHANSEN: Their insulation of course is poor.

HART: The insulation is markedly inferior. With the husky dog, you apparently never reach the condition where the temperature is low enough to cause this effect.

HANNON: Along similar lines it might be worth mentioning that the rectal temperatures of cold acclimatized rats are quite readily elevated to very high levels when they are injected or infused intravenously with norepinephrine. A number of times, for example, we have observed body temperatures as high as 43°C or 44°C in experiments with this hormone.

JOHANSEN: Of course this concept of heterothermy and the potential of insulation somewhat invalidates the things we have been taught in school about the climatic rules. I was wondering whether Dr. Irving would care to comment about how this might invalidate Allen's Rule about the length of extremities.

IRVING: I think those rules are useless.

PROSSER: There is still a correlation, just the same.

IRVING

IRVING: I am not sure there is among the different caribou; the smallest of all is also the most northern. You find many exceptions to that; and as Scholander says, if this were a matter of a law of heat you should not find any exceptions. Thus, one exception would invalidate the significance of such a law. It may be true that many birds as they go north get longer tails, larger bodies, or bigger claws. On the other hand, some do just the opposite. I do not think it has ever been shown that any of these differences in body dimensions are significant to the heat economy of the animal. I will go farther and say that the surface of an animal has no relation to its heat exposure; there is no relation that you or I can define, because in the first place there is no geometrician who can define the surface of such an irregular object as an animal. It is indescribable, mathematically. If it were describable, it would not be worth the time or the effort, and further, attributing the heat loss simply to the surface disregards practically all that we know that is interesting and important with regard to the conservation and dissipation of heat. In other words, it is not a matter strictly of surfaces. For example, the circulation through the skin of the fingers is one hundred times what it is through the skin on the forearm or on the rest of the body. The variability in the amount of circulation, the amount of heat exchange, and the temperature of blood passing through the extremities are far more important factors than is the extent of the skin surface. And those are the variable factors in heat economy, while surface, if there be such a thing, is an invariable function unless the animal chooses to alter his posture, as he does in sleep.

PROSSER: But still there is a general correlation between size and distribution; it may have no relation to temperature regulation at all, but it remains as a correlation.

IRVING: That may be, but it is not of any great interest or importance to physiology.

PROSSER: I am not willing to say that. It may have some meaning which we do not know.

MORRISON: Do you think it is fair to say that a factor has no significance simply because there are other factors which are more significant?

HETEROTHERMY IN HOMEOTHERMS

IRVING: Yes, it has less significance, because it conceals or disregards the physiologically important and interesting things, which are the variability in temperature and circulation of the different areas.

MORRISON: Well, would you then say that the high levels of hemoglobin in a diving animal are of no significance in the prolongation of diving, because they would not allow anything like the observed increases in diving time and because the circulatory changes are so much more important? Is there not an analogy here?

IRVING: No, I would not say that the oxygen capacity of the blood is unimportant for the seals. It is very important. It is not the large factor in the prolongation of their dives, but presumably if the blood has twice the oxygen capacity it has at least doubled the transport capacity and the rate of recovery. If you get double the oxygen capacity and improve the elasticity of the whole vascular system, then recovery is apparently attributed to those factors. One of the remarkable things about such diving animals, incidentally, is not only the prolonged diving but also the rapidity with which they can recover and take another dive.

MORRISON: But when we have a factor that is advantageous, when are we to say that it no longer has any significance as long as it is in the right direction? Can we not say that it may have selective significance, even if it is only at the 10% or 5% level?

IRVING: Then you get one of these instances of statistical significance. You are talking about imperceptible adaptations which gradually accumulate by some statistical process to become of visible importance.

JOHANSEN: If you go back to heterothermy, the point here is that these extremities provide insulation, and if they are larger they provide more insulation.

MORRISON: If you do not have extremities, insulation (= conductance) is better.

IRVING

JOHANSEN: No, such a situation is unrealistic and has no relevance to the situation.

MORRISON: If you amputate the leg, you are going to lose less heat from it.

PROSSER: Also, there might be differences which would show up in a population analysis that would not be of any measurable advantage to an individual as such. However, they might be of importance to the whole population.

MAXIMAL STEADY STATE METABOLISM AND ORGAN THERMOGENESIS IN MAMMALS

L. Jansky

The studies of basal metabolic rates in mammals and the relation of metabolic rates to body weight have been the subject of many papers and reviews since the middle of the nineteenth century. These studies have not confirmed the validity of the "surface area theory" and have proved that the basal metabolic rates were proportional to $W^{0.75}$ where W is the body weight (Kleiber, 1947).

On the other hand, very few data are available on the upper limits of metabolic rate that can be sustained for long periods in different species. It is known that very high rates of heat production, up to 100 times the basal level, can be measured in man and horse under extreme exercise (Brody, 1945). However, these rates cannot be sustained for long periods and do not result from steady state effort. Methods of estimating steady state effort and a comparison of results in different species varying in body weight will be considered in this paper. In addition, the total cytochrome oxidase activity, which can yield values for metabolism which are theoretically maximal in different species (Jansky, 1961), will also be considered. This method also provides a means for estimating the theoretical maximal values for different organs of the same species and their relative contributions to the metabolic capacity of the whole animal.

Maximal Steady State Metabolism

For the purposes of this paper, the upper limit of metabolism will be called the "maximum steady state metabolism" and will be defined as the highest oxygen consumption compatible with sustained aerobic effort when there is no progressive accumulation of lactic acid in muscles. It is known for man (Wells et al., 1957) rats (Sreter and Friedman, 1958), and deer mice (Hart and Heroux, 1954) that a certain level of exercise can be attained without accumulation of

lactic acid and that this level of exertion can be sustained for long periods. In practice, lactic acid is not usually measured, and maximal steady state metabolism during exercise is determined at the highest running speed, which can be sustained for about 20-40 minutes.

During exposure to cold there is also a marked increase in metabolism which can be maintained for long periods. The question therefore arises as to whether there is a relationship between the maximal working metabolism and the highest level of metabolism that can be obtained in the cold.

Experiments on man have shown that it is possible to attain the maximal steady state metabolic level only under intensive work conditions and that the effect of cold does not add to the metabolic rate during work (substitution theory - Lefevre, 1933, 1934). On the other hand, tests on some small mammals have shown that maximal oxygen consumption is possible with simultaneous application of work and lowered temperatures, so that the working and cold thermogenesis occur at the same time, (addition theory - Chevillard, 1935; Hart, 1950; Hart and Heroux, 1955; Jansky, 1959, a, b, c).

In the tests on small mammals, the measurement of maximal steady state metabolism during work and exposure to cold is very difficult, owing to the rapid development of hypothermia which eventually causes a decline in heat production. Figure 1 shows a distinct drop in the oxygen consumption of white mice which started immediately at the beginning of the work in extreme cold (Jansky, 1959a). Decline of metabolism presumably due to hypothermia was found at the lowest temperatures in most of the species investigated.

Since the values obtained on hypothermic animals could not be considered maximal, it was necessary, therefore, to perform the tests at various temperatures to find the lowest temperature at which working oxygen consumption was maximal and did not decrease during the test period (40 minutes).

Results obtained on various small mammals showed that there were species differences in the effect of work and cold on metabolism. In rabbits and lemmings (Hart and Heroux, 1955) in white mice

ORGAN THERMOGENESIS

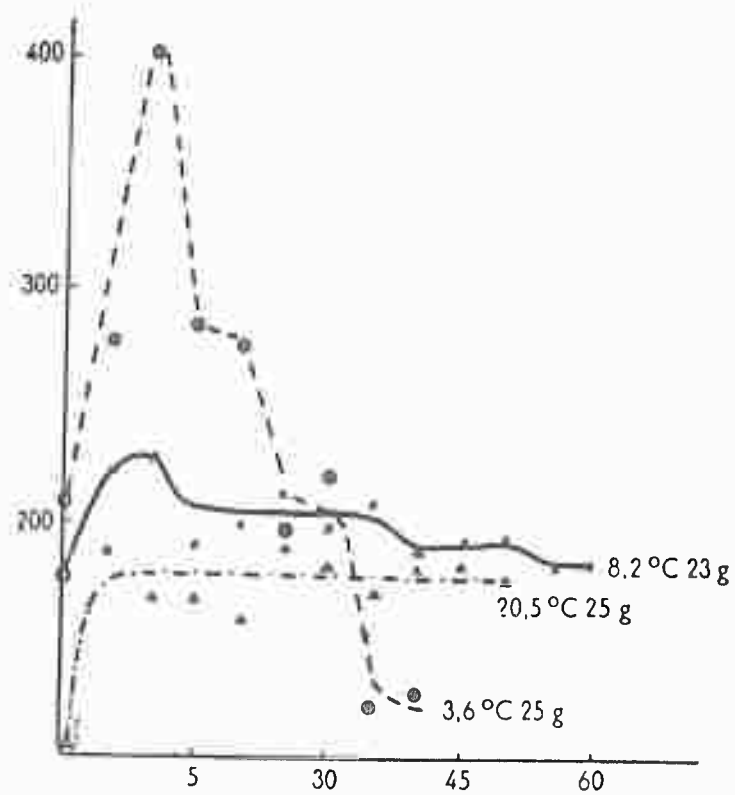

Figure 1. The time course of working oxygen consumption of the mouse at various temperatures. Ordinate: oxygen consumption in ml O₂/hour/animal; Abscissa: time in minutes. (Jansky, 1959a).

(Hart, 1950; Jansky, 1959a), and in golden hamsters (Jansky, 1959c), kept at laboratory constant temperatures, the working oxygen consumption increased with decreasing temperature. Oxygen consumption during work was added directly to the cold thermogenesis, giving two parallel curves (Figure 2). These results confirmed the validity of the addition theory and showed clearly that the highest values of metabolism could be measured only after simultaneous application of cold and work.

Contrasting results have been obtained on two wild rodents, the common vole (Microtus arvalis) and the bank vole (Clethrionomys glareolus) (Jansky, 1959b), kept for a short period at naturally fluctuating temperatures. Both species are closely related and have the same average weight (18 gm). In the common vole, the typical addition relationship between working and resting heat production in the cold was observed. In the bank vole, on the other hand, the metabolism during maximal work below the thermoneutral zone did not increase to the same extent as that during rest with decrease in temperature. Therefore the heat production during work partially substituted for the cold thermogenesis. This was particularly clear when the maximal running speeds of the two species of voles are considered (Figure 3). Although there was a slight increase in running speed with lowering of temperature from 25° C to 5° C, in both species, there was a decrease in the difference between working and resting metabolism in the bank vole but not in the common vole (Figure 2). When the lowest temperature was reached, both the running speed and the difference between working and resting metabolism were greatly reduced. The common vole had a greater range for maximal work than did the bank vole in both heat and cold.

These experiments have shown that the metabolic differences among various species of mammals do not depend on the weight of the animals or on their phylogeny. The only obvious difference between the common vole and the bank vole lies in the ecology of both species and in their acclimatization to various temperatures. Bank voles live in forests in deep burrows and build well-insulated nests and are not, therefore, exposed directly to the effect of low temperatures. Common voles, on the other hand, live in meadows in superficial burrows almost without nesting material and are forced more often to endure extreme temperatures. This is reflected in

ORGAN THERMOGENESIS

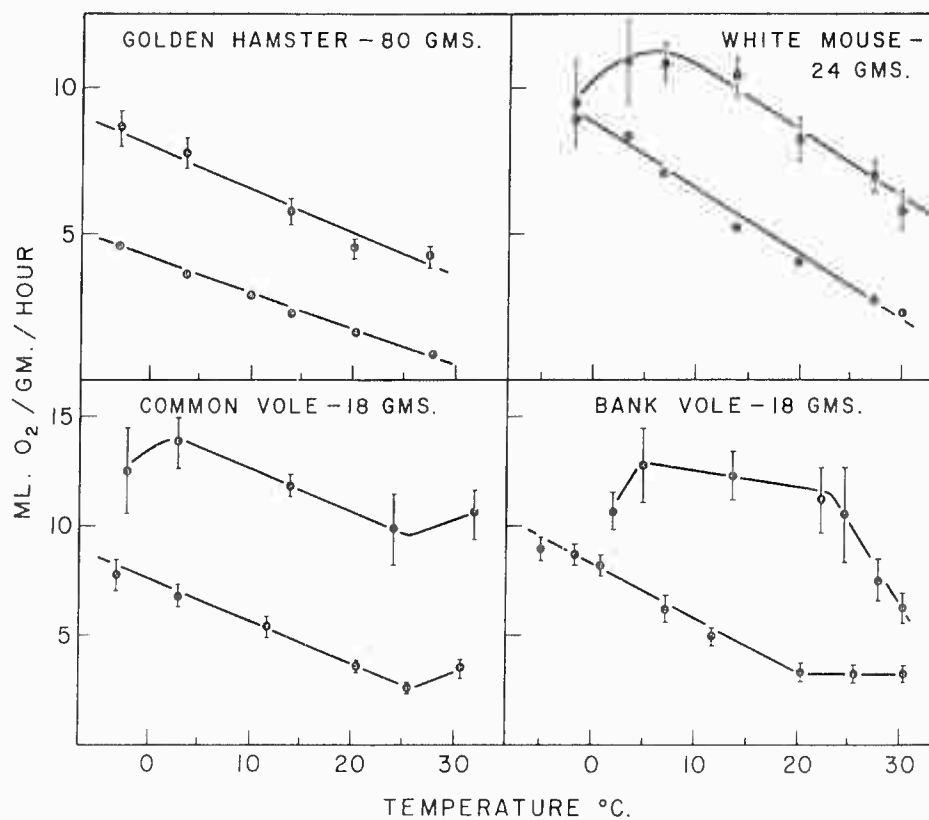

Figure 2. Working and resting oxygen consumption at different temperatures in various mammals.

JANSKY

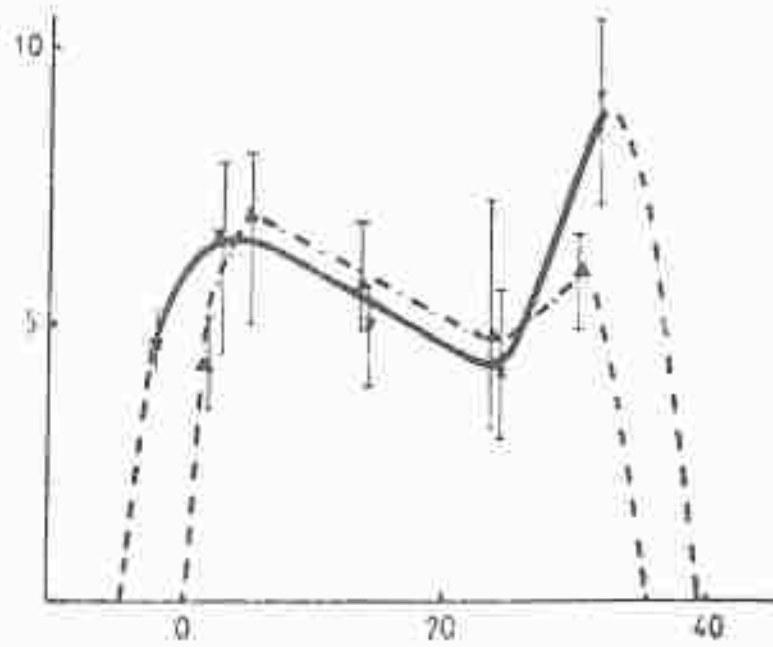

Figure 3. Maximal running speed of the common vole (x—x) and the bank vole (Δ—Δ) at various temperatures. Ordinate: running speed in m/min.; Abscissa: temperature in °C. (Jansky, 1959b).

ORGAN THERMOGENESIS

their greater abilities to run at high and especially at low temperatures.

Recently it has been shown (Hart, 1962, in press) that warm- and cold-acclimated rats behave differently with respect to substitution of exercise for cold thermogenesis. Warm-acclimated rats, having shivering thermogenesis only, substituted heat production from shivering by heat production from exercise. Oxygen consumption during work did not change with decreasing temperature and was identical to the maximal oxygen consumption in rest at the lowest temperatures. This is apparently due to the fact that exercise in cold may reduce or eliminate shivering. This was surmised long ago and recently demonstrated in pigeons during flight (Hart, 1960). On the other hand, in cold-acclimated animals, which can produce heat without shivering (Sellers et al., 1954; Heroux et al., 1956; Cottle and Carlson, 1956), the addition of exercise heat production to cold thermogenesis is made possible (Figure 4). The result is that working oxygen consumption increase with decreasing temperature parallel to resting values and the maximum heat production is greatly increased.

However, at temperatures approaching the peak metabolic rate for cold-acclimated rats, heat production during work did not increase with lowering of temperature. At these low temperatures, shivering was clearly visible in the resting rats, and mechanical work was substituted for shivering as in warm-acclimated rats (Hart, Jansky, unpublished). The values followed closely the broken line shown in Figure 4. As shown for warm-acclimated animals, the resting metabolism was, at very low temperatures, almost as great as the values of working metabolism.

It seems clear, therefore, that the substitution relationship between working and resting heat production exists in these animals only when shivering is replaced by gross physical activity. The additional relationship occurs over a certain range of temperatures in these animals, when non-shivering thermogenesis plays the dominant role in maintaining body temperature.

All these data show that the values of maximal metabolism are obtainable not only after simultaneous application of work and cold,

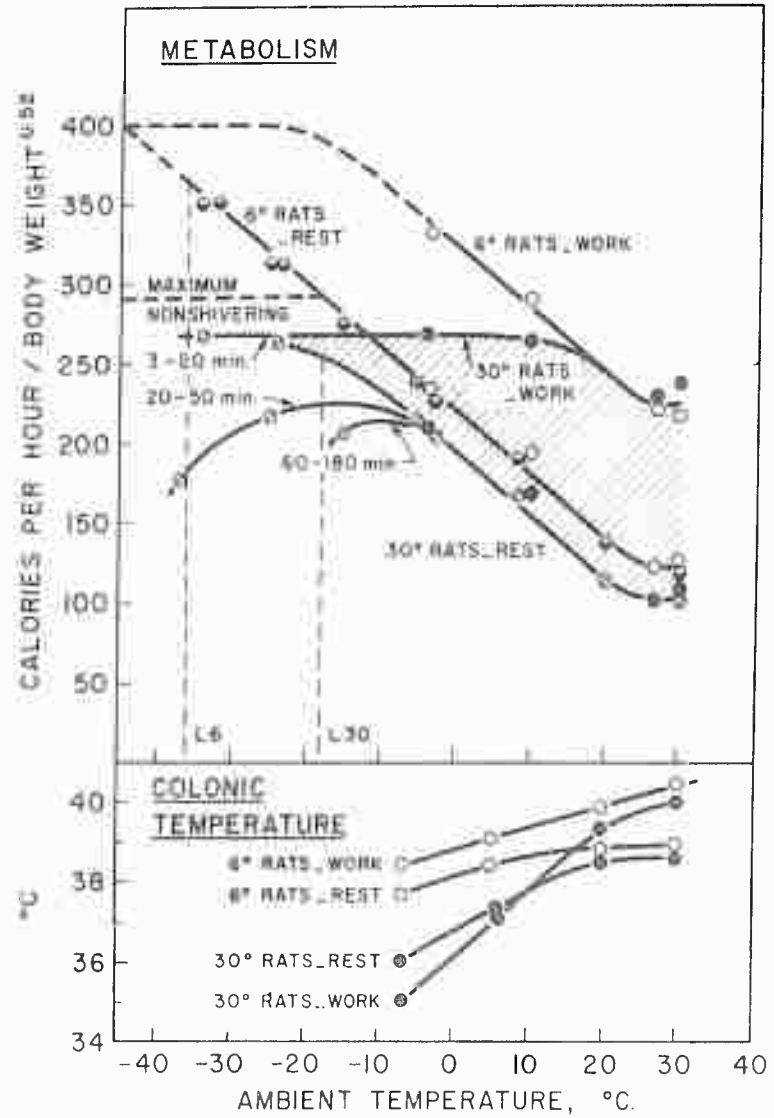

Figure 4. Working and resting oxygen consumption at various temperatures in cold and warm adapted rats. (Hart 1962, in press).

ORGAN THERMOGENESIS

but also in the resting state after exposure to low temperatures approaching the lethal level. Under the latter condition it is necessary to measure the oxygen consumption for a very short period after exposure to cold, because of the substantial drop in body temperature (Figure 4). This period is about 20 minutes long for the rat (Depocas et al., 1957).

Owing to the difficulties described above in measuring maximal steady state metabolism, relatively few values have been published for mammals (Chevallard, 1935; Hart, 1950; Jansky, 1959a for the white mouse; Hart and Heroux, 1955 for the lemming and rabbit; Jansky, 1959b for the bank and common voles; Jansky 1959c for the golden hamster; and most recently by Buskirk and Taylor, 1957, for man). One can expect that rather larger species differences might occur, owing to differences in body size, posture, hair insulation, blood circulation, and air movement, which might be quite different during maximal metabolism than during the resting state and could have a different effect on the amount of heat dissipation.

When all published values of maximal steady state metabolism are plotted against the log body weight of the animals (Figure 5), it was found that maximal steady state metabolism is equal to about six times and basal rate, with a body weight exponent very close to that found for basal metabolism. All the species examined have, therefore, nearly the same capacity to increase energy metabolism from the basal to the maximal steady state level. Species differences in posture, insulation, and other factors that affect heat dissipation have no apparent effect on this capacity to increase heat production.

Total Cytochrome-oxidase Activity

Since the rapid cooling of small animals at low temperatures makes the measurement of maximal steady state metabolism quite difficult, an additional method was sought for measuring the highest metabolic capability of animals and tissues.

It can be assumed that the total oxidative activity of tissues cannot be greater than that of the activity of the only terminal oxidative enzyme, cytochrome oxidase. In other words, it is supposed that the

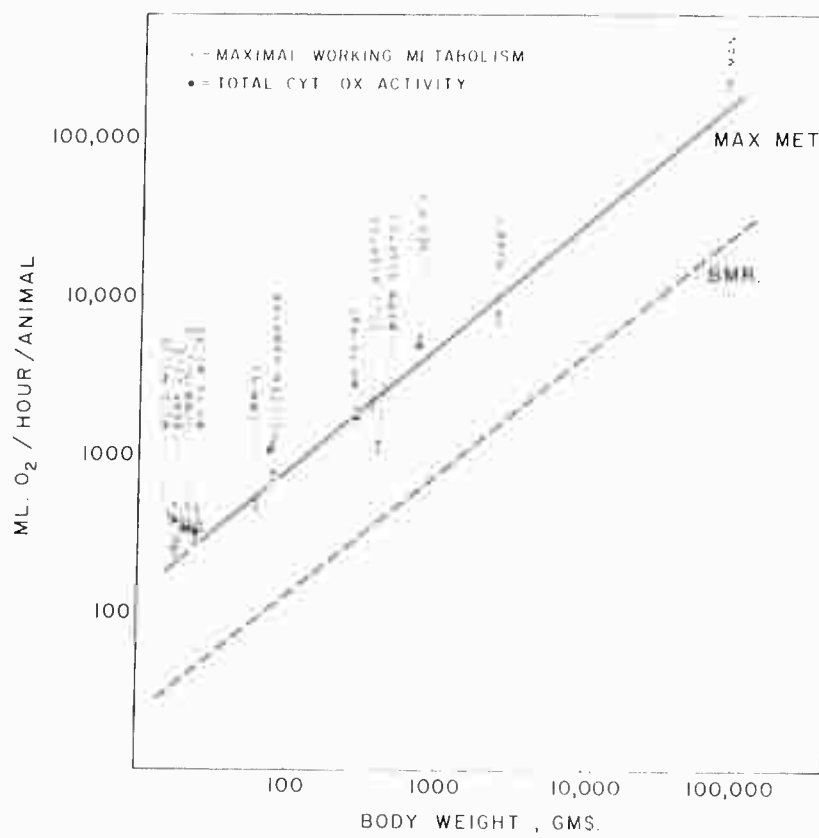

Figure 5. Relationship of maximal steady state metabolism and total cytochrome oxidase activity to body weight in various mammals.

ORGAN THERMOGENESIS

maximal oxidative activity of this enzyme corresponds to the highest tissue oxygen consumption. It can also be assumed that cytochrome oxidase does not occur in excess quantity in tissues, because cytochrome oxidase activity readily becomes adapted to various conditions (Tipton and Nixon, 1946; Hannon, 1960). For these reasons the cytochrome oxidase activities of whole animals and their tissues were examined to find whether the values were related to the maximal steady state oxygen consumption.

The method selected for use in these studies was the classic manometric method of Schneider and Potter (1943), in which cytochrome oxidase activity can be measured in terms of oxygen consumption. The cytochrome oxidase activity was measured in a homogenate of the whole animal for direct comparison with the values of maximal steady state metabolism. Before homogenation indistilled water, the animals were depilated and after removal of their digestive tract, they were ground in a meat grinder. Oxygen consumption of the homogenate was measured at 37 °C.

The total cytochrome oxidase activity was determined in seven species of rodents (wood mouse - Apodemus sylvaticus, bank vole - Clethrionomys glareolus, common vole - Microtus arvalis, white mouse, golden hamster, rat, guinea pig) in the range of body weight from 17 to 700 gms. It was found (Figure 5) that the exponent of the relationship between total cytochrome oxidase activity and body weight was very similar to that found for basal and maximal metabolism (Jansky, 1961).

By comparison of the absolute values of oxygen consumption, obtained in vitro, using cytochrome oxidase activity and those in vivo at the level of maximal steady state metabolism, only small differences were found.

In spite of close agreement between in vivo and in vitro values, they are not considered to be identical. Both methods are completely different, and we cannot expect to be able to imitate the same conditions in vitro as in living cells, where the concentration and composition of substrates, pH and various other factors can change during the maximal performance of the organism. In addition there is a possibility that certain organs such as kidney, brain, or gonads are

not performing at maximal capacity when the animal is engaged in maximal steady state effort. This may explain the tendency for cytochrome oxidase values to be higher than maximal working metabolism in the various species.

It is, therefore, suggested that the terms "maximal steady state metabolism," be used for values obtained in vivo and "total cytochrome oxidase activity" be used for values obtained in vitro, which represents the highest theoretical value of oxidative metabolism (metabolic capacity).

Cytochrome Oxidase Activity in Body Organs

The values of total cytochrome oxidase activity are useful for comparative purposes and seem to be especially suitable for estimating the metabolic capacity of different body organs. At present, we do not know of any other method for assessing maximal performance of body organs. The cytochrome oxidase method can provide some information on the relative roles of different organs in the total metabolic capacity of the whole animal.

The cytochrome oxidase activity was measured in 10 of the most important organs (carcass, liver, skin, kidney, brain, lung, heart, diaphragm, spleen, and gonads) in the golden hamster (Svoboda and Jansky, 1959). Some other preliminary experiments were made on the white mouse and on the rat.

In general, the highest cytochrome oxidase activity per mg of dry substance was found in the heart, kidney and brain, the lowest in the carcass and in the skin. The cytochrome oxidase activity per mg dry substance in the same organs of various species seems to decrease in heavier animals.

The most important consideration for our purposes is the ratio of cytochrome oxidase activity in whole organs to the total cytochrome oxidase activity of the whole animal. The results on the golden hamster show very clearly that the muscles play the most important role. At body temperature (37°C), they represent about 76% of

ORGAN THERMOGENESIS

the theoretical total metabolic capacity (Figure 6). The role of other organs is relatively small. The most important are skin (9%), liver (5%), brain (3%), and gonads (3%). Similar observations were also made on the rat.

Organ Thermogenesis in vivo

Owing to the large contribution of the muscles and the minor contribution of visceral organs in the total cytochrome oxidase activity of hamsters and rats, it is important to consider the relative contribution of these organs in vivo to the maximal steady state metabolism. At present only indirect estimation can be made on the role of muscle in intact animals. In warm acclimated rats (Figure 4) the maximal steady state metabolism is approximately $270 \text{ Cal}/(\text{hour} \times \text{body weight}^{0.52})$. The increase of metabolism from the basal level ($100 \text{ Cal}/(\text{hour} \times \text{body weight}^{0.52})$) is about $170 \text{ Cal}/(\text{hour} \times \text{body weight}^{0.52})$, which is 63% of maximal metabolism ($270 \text{ Cal}/\text{hour}$). Since shivering is the principal source of heat in these rats exposed to cold, it can be assumed that the cold thermogenesis is due to muscles. In addition to the cold thermogenesis, it has to be estimated that the participation of muscles in the basal state amounts to about 30% of the total metabolic rate (Field et al., 1939). This would be approximately 10% of the maximal rate in these tests. The total contribution of the muscles to the maximal metabolism would therefore be 73% (63% + 10%).

In cold acclimated rats the quantitative estimation of the role of the muscles is more complicated. In addition to shivering, the non-shivering thermogenesis is developed (Sellers et al., 1954; Heroux et al., 1956; Cottle and Carlson, 1956), which increases the maximal metabolic rate to about $420 \text{ Cal}/(\text{hour} \times \text{body weight})$ (Figure 4). In order to estimate the contribution of muscles under these conditions, the site of non-shivering thermogenesis must first be ascertained.

The visceral organs have been considered as important sites of non-shivering heat production for many years. Much of the evidence has come from measurements of temperatures near the liver (Grayson and Mendel 1956; Donhoffer et al., 1957). In cold acclimated rats, the elevation of BMR and the elevation QO_2 in vitro give support to

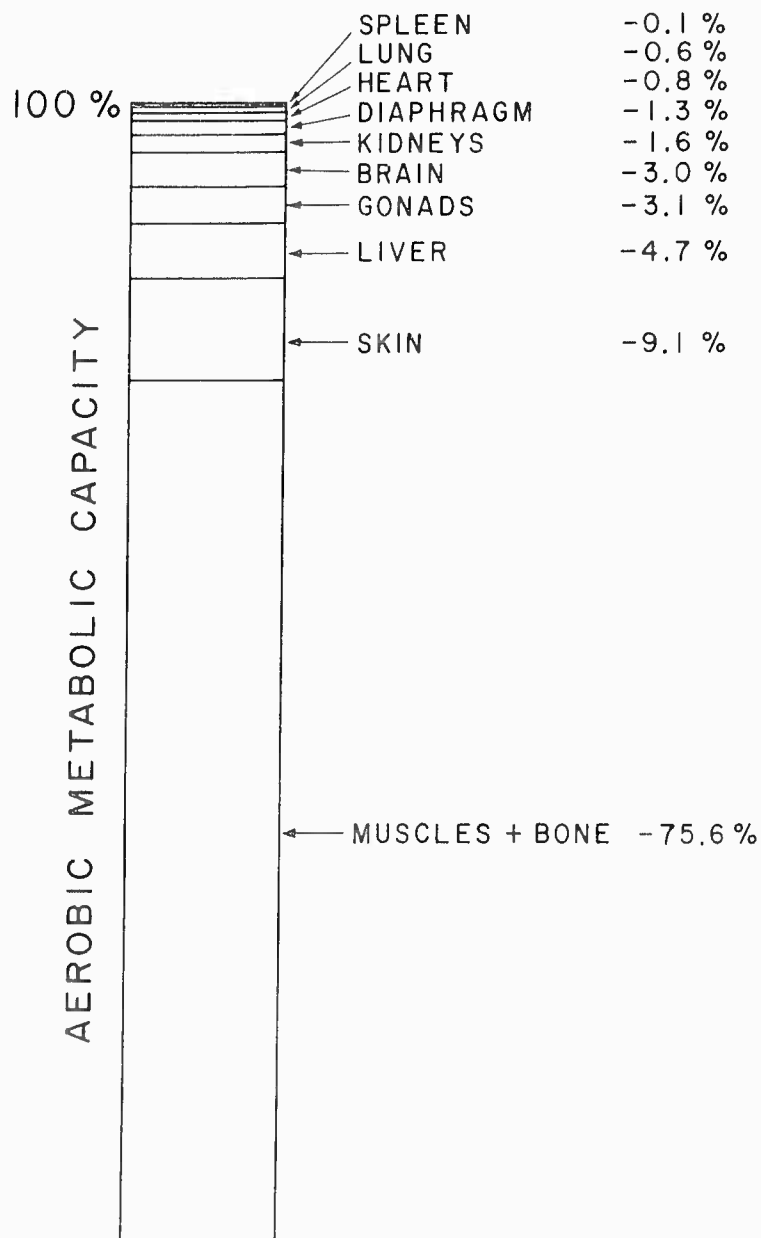

Figure 6. Contribution of various organs to the total metabolic capacity in the golden hamster as measured by cytochrome oxidase activity.

ORGAN THERMOGENESIS

the increased thermogenesis of visceral organs (Weiss, 1954). However, direct evidence on the magnitude of the contribution is lacking.

On the other hand, evidence against the visceral organs as the important site of heat production in non-shivering was provided by Depocas (1958) who found, that the metabolic response to cold in curarized cold acclimated rats was not reduced by functional evisceration. Supporting evidence that the liver did not greatly contribute to increased heat production in cold was provided by Kawahata and Carlson (1959) in cold acclimated rats. Similar observations have recently been obtained for the kidney (Jansky and Hart, unpublished). On the other hand, direct evidence for the participation of muscle in cold thermogenesis was obtained by Jansky and Hart (unpublished) in the leg muscles of cold acclimated curarized rats where elevation in oxygen consumption equal to that in the whole animal were found during exposure to cold.

While thermogenesis from visceral organs still cannot be excluded, it can be concluded that both shivering and non-shivering thermogenesis are dependent to an important extent on the muscles. The total increase in heat production of cold-acclimated rats from the basal level ($125 \text{ Cal}/(\text{hour} \times \text{body weight}^{0.52})$) is about $295 \text{ Cal}/(\text{hour} \times \text{body weight}^{0.52})$, which is 75% of the maximal rate ($420 \text{ Cal}/\text{hour}$). If muscle accounts for the entire cold thermogenesis, this would be equivalent to 77% of maximal metabolism, when the contribution of muscle to the basal metabolism is also considered.

The calculations again agree closely with the large proportion of muscle to the total cytochrome oxidase activity in hamsters and rats and show that as an upper limit, muscle could contribute about the same proportion to metabolism in both warm and cold acclimated rats. However, it is clear that the absolute increase in maximal metabolism of cold acclimated rats would require an increase in absolute values of cytochrome oxidase activity in the organs concerned. These observations, which are incomplete and permit only tentative conclusions, will be extended by work now in progress on the cytochrome oxidase activity of the muscles and other organs in warm and cold acclimated rats.

SUMMARY

The measurement of maximal steady state metabolism is complicated by the fact that both cold exposure and exercise may be required to elicit the maximal response and by the fact that the effect of exercise and cold varies with environmental temperature, state of acclimation, and other factors. In most small mammals studied, the metabolic effect of exercise is added directly to the cold thermogenesis, but in the bank vole and in warm acclimated rats, exercise substitutes for shivering and replaces cold thermogenesis. In cold acclimated rats, the metabolic effect of exercise is added to cold thermogenesis, except at the lowest test temperatures where substitution is again observed. The varied responses of different species and of cold- and warm-acclimated rats apparently depend on the extent of participation of non-shivering thermogenesis, which extends the range for activity and increases the maximal steady state metabolism. Maximal steady state metabolism can be determined either by imposing exercise simultaneously with cold or by exposing the subject to cold alone at very low temperatures.

The maximal steady state metabolism of different species was equal to about six times the basal metabolism, and the exponent relating log metabolism to log body weight was not obviously different from that for basal metabolism ($W^{0.75}$) for the species tested. Basal and maximal metabolism, therefore, give two parallel curves.

The total cytochrome oxidase activity was also measured in homogenates of whole animals. It was found that the exponent of the relationship between cytochrome oxidase activity and log of the weight was very similar to that found for basal and maximal metabolism. There was a close similarity between absolute values of maximal metabolism, and the total cytochrome oxidase activity provides a theoretical upper limit to the metabolic capability and is useful for comparative purposes in various species and organs of the same species.

The study of body organ cytochrome oxidase activity in the golden hamster illustrates the importance of the muscles, which comprise about three fourths of the total cytochrome oxidase activity.

ORGAN THERMOGENESIS

This fact agrees with observations on the site of thermogenesis in living animals, where either shivering alone or shivering and non-shivering thermogenesis together are responsible for maintaining body temperature in cold environments.

*Contribution from the Division of Applied Biology, National Research Council, Ottawa, Canada, and Department of Comparative Physiology, Natural Science faculty, Charles University, Prague, Czechoslovakia. Issued as N.R.C. No. 6579. Postdoctoral Fellow, National Research Council, 1960-61.

JANSKY

LITERATURE CITED

1. Brody, S. 1945. Bioenergetics and growth. Reinhold Publishing Corp. New York. p.915.
2. Buskirk, E. and H. L. Taylor. 1957. Maximal oxygen intake and its relation to body composition with special reference to chronic physical activity and obesity. *J. Appl. Physiol.* 11: 72-78.
3. Chevillard, L. 1935. Contributions a l'etude des echanges respiratoires de la souris blanche adulte. II. Thermogenese et Thermogenese et thermolyse de la souris. *Ann. physiol. physicochim. biol.* 11:485-532.
4. Cottle, W. H. and L. D. Carlson. 1956. Regulation of heat production in cold adapted rats. *Proc. Soc. Exp. Biol. Med.*, 92:845-849.
5. Depocas, F., J. S. Hart, and O. Heroux. 1957. Energy metabolism of the white rat after acclimation to warm and cold environments. *J. Appl. Physiol.* 10:393-397.
6. Depocas, F. 1958. Chemical thermogenesis in the functionally eviscerated cold-acclimated rats. *Can. J. Biochem. Physiol.* 36:691-699.
7. Donhoffer, Sz., Gy. Szevgari, I. Varga-Nagy, and I. Jarai. 1957. Über die Lokalisation der erhöhten Wärmeproduktion bei der chemischen Wärmeregulation. *Pflügers Arch.* 265:104-111.
8. Field, J., H. S. Belding, and A. W. Martin. 1939. An analysis of the relation between basal metabolism and summated tissue respiration in the rat. I. The post-pubertal albino rat. *J. Cell. and Comp. Physiol.*, 14:143-157.
9. Grayson, J. and D. Mendel. 1956. The distribution and regulation of temperature in the rat. *J. Physiol.* 133:334-346.

ORGAN THERMOGENESIS

10. Hannon, J. P. 1960. Effect of prolonged cold exposure on components of the electron transport system. *Am. J. Physiol.* 198: 740-744.
11. Hart, J. S. 1950. Interrelations of daily metabolic cycle, activity, and environmental temperature of mice. *Can. J. Research, D*, 28:297-307.
12. Hart, J. S. and O. Heroux. 1954. Effect of low temperature and work on blood lactic acid in deer mice. *Am. J. Physiol.* 176: 452-454.
13. Hart, J. S. and O. Heroux. 1955. Exercise and temperature regulation in lemmings and rabbits. *Can. J. Biochem. Physiol.* 33:428-435.
14. Hart, J. S. 1960. The problem of equivalence of specific dynamic action: Exercise thermogenesis and cold thermogenesis in Cold Injury, Transactions of the 6th Conference, July, 1958. Josiah Macy, Jr. Foundation, New York.
15. Hart, J.S. 1962. Physiological adjustments to cold in non-hibernating homeotherms. Proc. of the 4th Symposium on Temperature. Am. Inst. of Physics, in press.
16. Heroux, O., J. S. Hart, and F. Depocas. 1956. Metabolism and muscle activity of anesthetized warm and cold acclimated rats on exposure to cold. *J. Appl. Physiol.* 9:399-403.
17. Jansky, L. 1959a. Oxygen consumption in white mouse during physical exercise. *Physiol. Bohemoslov.* 8:464-471.
18. Jansky, L. 1959b. Working oxygen consumption in two species of wild rodents (*Microtus arvalis*, *Clethrionomys glareolus*). *Physiol. Bohemoslov.* 8:472-478.
19. Jansky, L. 1959c. Einfluss der Arbeit und der niedrigen Temperaturen auf den Sauerstoffverbrauch des Goldhamsters. *Acta Soc. Zool. Bohemoslov.* 23:266-274.

20. Jansky, L. 1961. Total cytochrome oxidase activity and its relation to basal and maximal metabolism. *Nature* 189(4768):921-922.
21. Kawahata, A. and L. D. Carlson. 1959. Role of rat liver in non-shivering thermogenesis. *Proc. Soc. Expt. Biol. Med.* 101:303-306.
22. Kleiber, M. 1947. Body size and metabolic rate. *Physiol. Rev.* 27:511-541.
23. Lefevre, J. and A. Auguet. 1933. La thermoregulation du travail. Rapports de ses courbes avec celles du repos. *Ann. physiol. physicochim. biol.* 9:1103-1121.
24. Lefevre, J. and A. Auguet. 1934. Les courbes thermoregulatrices et les rendements de la machine vivante dans les grandes puissances de travail. *Ann. physiol. physicochim. biol.* 10:1116-1134.
25. Schneider, W. C. and V. R. Potter. 1943. The assay of animal tissues for respiratory enzymes. II. Succinic dehydrogenase and cytochromoxidase. *J. Biol. Chem.* 149:217.
26. Sellers, E. A., J. W. Scott, and N. Thomas. 1954. Electrical activity of skeletal muscle of normal and acclimated rats on exposure to cold. *Am. J. Physiol.* 177:372-376.
27. Sreter, F. A. and S. M. Friedman. 1958. Sodium, potassium and lactic acid after muscular exercise in the rat. *Can. J. Biochem. Physiol.* 36:1193.
28. Svoboda, L. and L. Jansky. 1959. Sexual differences in the cytochrome oxidase activity of different organs of the gold hamster. *Physiol. Bohemoslov.* 8:552-557.

ORGAN THERMOGENESIS

29. Tipton, S. R. and W. L. Nixon. 1946. The effect of thiouracil on the succinoxidase and cytochrome oxidase of rat liver. *Endocrinology* 39:300-306.
30. Weiss, A. K. 1954. Adaptation of rats to cold air and effects on tissue oxygen consumptions. *Am. J. Physiol.* 177:201-206.
31. Wells, J. G., B. Balke, and D. D. van Fossan. 1957. Lactic acid accumulation during work. A suggested standardization of work classification. *J. Appl. Physiol.* 10:51.

JANSKY

DISCUSSION

HANNON: I was particularly interested in your cytochrome oxidase measurements since we have assayed the activity of this enzyme in the liver and muscle of warm and cold acclimatized rats. As you are no doubt aware the manometric technique for measuring cytochrome oxidase leaves a lot to be desired. Despite this, however, we have used the same procedure as you have and have found that cold acclimatization leads to a marked increase in the activity of this enzyme in both liver and muscle tissue. Besides this acclimatization effect, we were also most interested in the fact that our studies showed the liver has about six times more cytochrome oxidase than muscle. Thus, if this enzyme is an index of maximum metabolic capability, as you suggest, the liver would have six times greater metabolic capacity per gram of tissue than muscle. And, to speculate a bit further, if we assume that the level of cytochrome oxidase reflects the capacity of a tissue to produce heat and if we take into account the fractions of the total body mass represented by liver and muscle, then the theoretical ratio of total muscle heat production to total liver heat production would be about 2:1. It will be most interesting to see whether or not this theoretical ratio will be verified by future experiments where organ heat production is directly measured.

JANSKY: In our own recent experiments concerning the cytochrome oxidase activity in various organs of cold acclimated rats we have found a liver:muscle ratio of 2.5:1 for cytochrome oxidase activity. These values of organ cytochrome oxidase correspond to the values of maximal metabolism, which can be measured in working animals or animals exposed to extreme cold. At present it is practically impossible to measure organ heat production in moving animals or on animals in extreme cold. The body temperature of small laboratory animals falls very rapidly under these same conditions.

HANNON: In your data on mice and rats I noticed a convergence of the curves for work metabolism with the curves for metabolism in the cold. In the golden hamster, on the other hand, such a convergence was not apparent. If you had carried the temperature lower, do you feel the same convergence might have occurred in the hamster?

ORGAN THERMOGENESIS

JANSKY: Yes, I think this does look like incomplete results but I have good evidence that the metabolism in the golden hamster will fall at lower temperatures. When I measured the highest running speed the values fell very rapidly at low temperatures; therefore I expect it will also happen in the white mouse, the common vole, and the bank vole.

HANNON: Did you ever compare the absolute amounts of running, say over a period of a day, for animals living in a cold environment and animals living in a warm environment?

JANSKY: No, we measured activity only during the short-time experiment. It was the forced activity or, better to say, running at the highest level which could be obtained at a certain temperature. The animals were not adapted to definite conditions.

HANNON: We have conducted a few experiments on voluntary running of rats living in both warm and cold environments and have observed a tendency for cold to reduce such activity. This would seem to agree with a prediction made some time ago by Dr. Hart that running is an inefficient method for augmenting heat production in the cold. I would like to ask Dr. Hart if he has ever confirmed this prediction experimentally.

HART: Yes, but I have not published it. I did some measurements on rats a few years ago, and there seems to be a range of decreasing temperatures over which running speed actually increases in the cold, reaches a peak, and then falls off again. I think Melvin Fregley has also done this type of work.

HANNON: At certain low temperatures they do increase their running speed?

HART: The activity depends upon the temperature and on the acclimation conditions. In cold acclimated rats it increases with fall in temperature to about 5^o C below which it declines as shown in Figure 7.

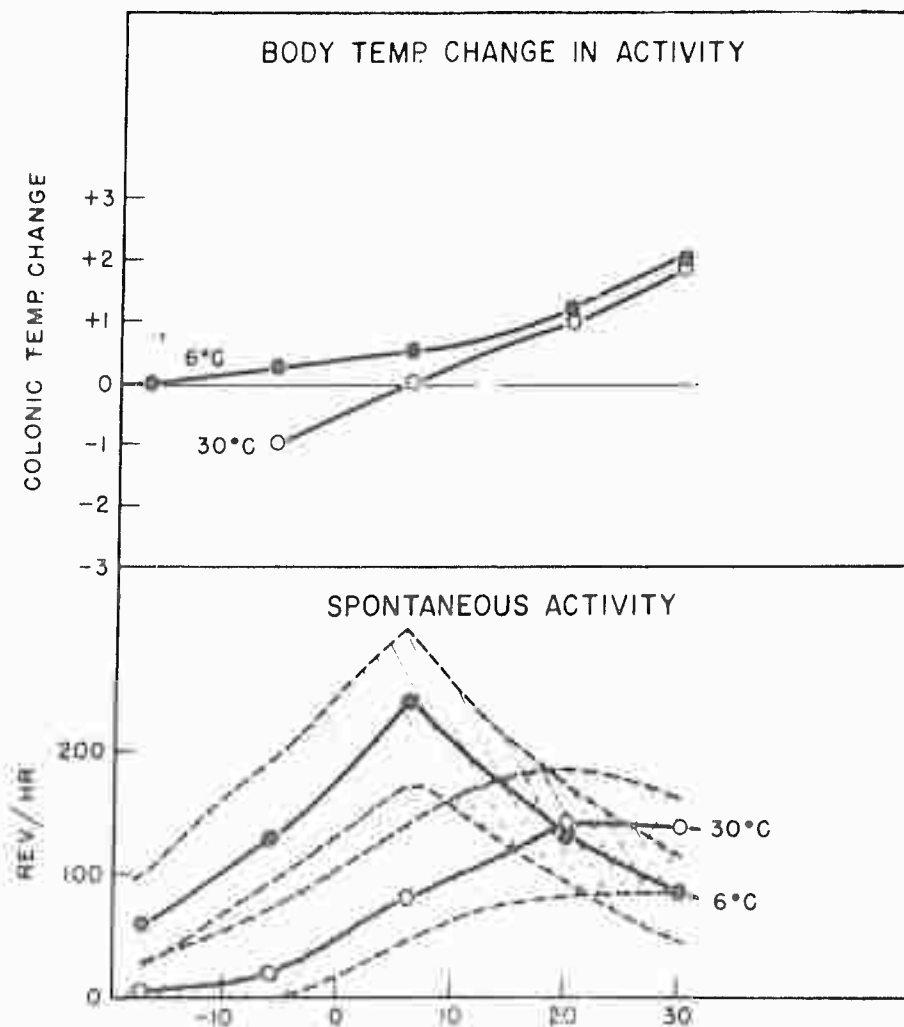

Figure 7. Upper panel: change in colonic temperature from initial resting state in rats running at 1400^a cm/min in a treadmill for 30 minutes at various temperatures. Symbols are for groups of 8 rats acclimated for 4 to 8 weeks to 6^o C, (●) and to 30^o C (○). The rats were exposed to each temperature for 10 min before start of run. Lower panel: mean spontaneous wheel activity of 4 rats acclimated to 6^o C (●) and 8 rats acclimated to 30^o (○) tested twice at each temperature for one hour periods. Total range of variation shown by shaded areas. Same rats used in both tests show lowering of spontaneous activity at both high and low temperatures, especially those which cause hypothermia during forced exercise. Presented by J. S. Hart.

ORGAN THERMOGENESIS

FOLK: The temperature of the running wheel may be a factor here. If the feet are well protected, some species of animals might make out all right, especially the white rat running on the cold metal. The colder it gets, the more this factor might influence the animal.

HANNON: How did you force your animals to work? We tried this and had all sorts of problems.

JANSKY: All animals were running in a wheel made from plastic. I attempted to get really maximal values of running and to avoid having them change their position; they could not turn back, for instance. In the axis of the wheel was a load, which could touch and excite the animals forcing them to run.

HANNON: Did you have any trouble? Dr. Drury in our laboratory has done similar forced-exercise experiments with the rat in a motor driven screen drum. Other people have tried to make their animals run on a treadmill. We, as well as the individuals to whom I have talked, have encountered a lot of foot and tail injury.

JANSKY: It depends upon which animal we use for the experiments. Some animals are better runners than others. The white rat for example is not a good runner. Many small animals run very nicely, since it is something like a natural movement for them. The species we used really did not need too much force.

FOLK: We have had a great deal of difficulty forcing exercise, and I did not quite understand how you got maximum running. You stimulated them, and I would like to hear more about that.

JANSKY: We used the wheel, and as I said, the wheel was narrow enough to prevent the animals from turning around. The animals, of course, were not restrained. On the axis of the wheel we suspended a load which was freely movable. This load was located behind the animal and would touch him if he ran slower. It was heavy enough to excite the animals. Another improvement

JANSKY

is a net to avoid gliding or riding the axle. Running speed was controlled with a Variac to prevent the animals from being carried by the wheel and we were thus able to obtain really maximal values.

HART: Did you keep increasing the speed until they could just maintain that position without being forced?

JANSKY: Yes, of course they sometimes stopped, but in this case the load touched them and they started again.

JOHANSEN: When you are comparing metabolic rates in these groups, that is, working and resting animals, it seems to me there will have to be a different insulation in the two. How would this reflect in your curves?

JANSKY: Comparing the values of maximal working metabolism and those of resting metabolism, we can see, that at the same environmental temperature the animals produce more heat at the level of maximal metabolism than in the resting state without a significant change in body temperature. This would suggest a certain decrease in total body insulation. On the other hand the values of maximal working metabolism in all species of animals that we studied form a definite exponent to the body weight. This would mean that there are no changes in total body insulation in working animals of different species.

KLEIBER: This change in insulation makes shivering inefficient because it increases the dissipation of heat.

HART: I am interested to know whether anyone has an opinion on the method of total cyt-ox activity as a measure of the theoretical maximum metabolic capacity.

HANNON: Theoretically, at least, this enzyme should be a good index of maximum metabolic capacity since most of the oxidative processes are eventually channeled through it. The manometric method of assaying it, however, is often open to criticism since you are using ascorbic acid to reduce the cytochrome c substrate. There is always a possibility that the ascorbic

ORGAN THERMOGENESIS

acid itself is being oxidized and at differential rates. A more modern and perhaps more accurate method of assaying cytochrome oxidase involves a spectrophotometric procedure where the cytochrome c substrate is reduced with hydrogen gas and palladium prior to its addition to the reaction system.

JANSKY: Of course there is a certain amount of autoxidation of ascorbic acid in the manometric procedure, but we can avoid it very easily by extrapolating to zero after measuring the oxygen consumption in Warburg flasks containing various concentrations of homogenate. I would say the spectrophotometric method is probably more convenient except that we cannot easily measure the oxygen consumption.

TEMPERATURE REGULATION AND ADAPTATION * TO COLD CLIMATES

J. Sanford Hart

Studies conducted largely during the last 10 years have provided us with a reasonably complete picture of the temperature regulation of mammals in cold climates. It is clear that several types of adjustments to cold are theoretically possible, having been described in previous reports by Scholander et al. (1950a) and Hart (1957). The most economical is structural modification in which insulation of the fur and tissues is increased to such an extent that very low ambient temperatures can be tolerated without increased energy expenditure. The most wasteful are metabolic modifications in which extremes of low temperature that limit survival are extended only by increase in metabolic rate. Behavioural adjustments (huddling, burrowing, etc.) can modify costly metabolic requirements through avoidance of cold.

The metabolic studies conducted on mammals have in general been limited to short term tests which do not provide an integrated picture of 24-hour energetics such as that provided for small birds. Nevertheless, within the limitation of the methodology it has been shown that quite distinct adaptive processes are in part dependent on differences in body size and also in part on broad differences between aquatic and non-aquatic animals. It will be the purpose of this review to describe the temperature regulation and adaptation to climate found in free living mammals. The term "acclimatization" will be used to describe individual physiological modification by climate in nature while the term adaptation will refer to differences between groups brought about through evolution. Other aspects of temperature regulation and acclimation to cold under laboratory conditions will not be considered in this review since they have been treated elsewhere (Carlson, 1954; Burton, 1955; Hart, 1957, 1958, and 1962; and recent symposia, 1955, 1957, and 1960).

*Contribution from the Division of Applied Biology, National Research Council, Ottawa, Canada. Issued as N.R.C. No. 6580.

Non-aquatic Fur Bearers

The large fur-bearing mammals have been investigated by American and Russian investigators. The best known work on this subject was published by Scholander et al. (1950a, b, and c), who were the only workers to demonstrate the existence of true evolutionary climatic adaptation. This demonstration was made by comparing arctic and tropical mammals with respect to metabolic rates at different temperatures and with respect to pelage insulation. It was found that the tropical mammals that were investigated were very sensitive metabolically to lowering of ambient temperatures, as shown by an abrupt increase in oxygen consumption with lowering of temperature. In contrast, the arctic mammals did not begin to increase their metabolism until they experienced much lower temperatures and some could virtually remain in a basal state at temperatures down to -40°C and below. The results for the tropical raccoon (Procyon cancrivorus or lotor), the small arctic lemming, and the Eskimo dogpup (Canis familiaris) (Figure 1) illustrate these distinctions. Using Scholander's terminology, it was observed that the critical temperature and the critical gradient for increase in oxygen consumption was lower in arctic mammals. Since the slopes of the curves were extrapolated to body temperature, the lower critical temperatures were associated with a smaller increase in metabolism for a given drop in temperature.

The distinction between arctic and tropical mammals was not associated with differences in the resting metabolism or in body temperature (Scholander, et al., 1950b), but with differences in body insulation. Arctic mammals were found to have greater pelage insulation (Scholander, et al., 1950c) than tropical mammals (Figure 2).

Some of the northern mammals investigated by Russian workers, for example Ol'nyanskaya and Slonim (1947) whose work is shown in Figure 3, were also relatively insensitive to cold but there was a very large individual variability within each species. The interpretation given to the data by the authors did not distinguish between zones of physical and chemical regulation; hence no apparent critical temperatures were noted. The rabbit (Lepus timidus), which showed an increase in oxygen consumption at temperatures below 20°C , differed from the Alaskan hare (Lepus americanus) studied

MAMMALIAN COLD ACCLIMATION

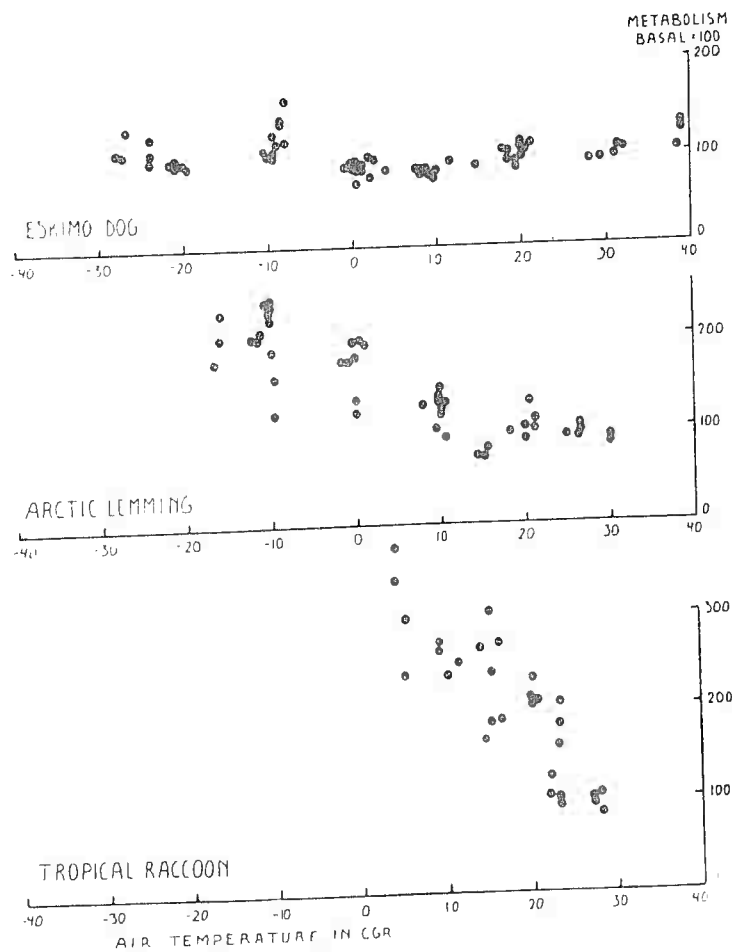

Figure 1. Effect of environmental temperature on the metabolic rates in eskimo dog, arctic lemming, and tropical raccoon, expressed in terms of basal metabolic rate = 100. From Scholander et al 1950.

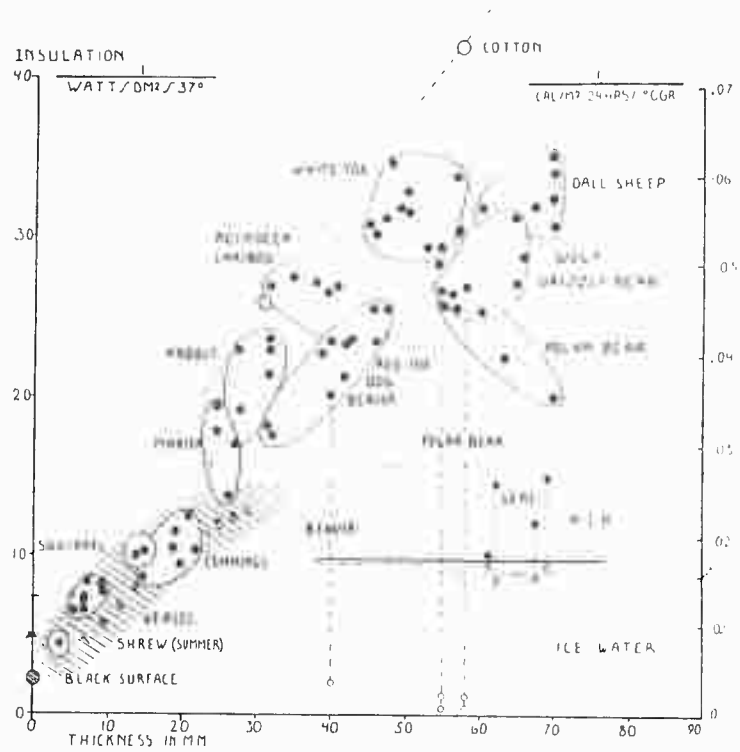

Figure 2. Insulation in relation to winter fur thickness in a series of arctic mammals. The insulation in tropical mammals is indicated by the shaded area. From Scholander et al., 1950.

MAMMALIAN COLD ACCLIMATION

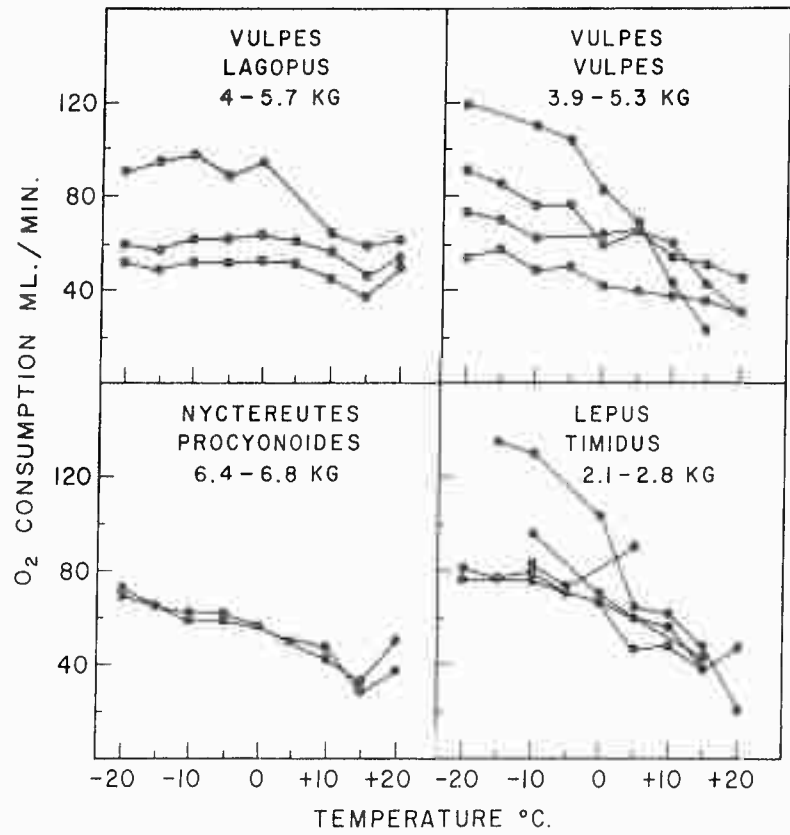

Figure 3. Effect of temperature on metabolism of some Siberian mammals. Redrawn from Ol'nyanskaya and Slonim, 1947.

HART

by Irving et al. (1955), in which metabolism did not increase until the temperature fell below -10°C .

The regulation of body temperature by arctic mammals and birds has been thoroughly investigated by Irving and Krog (1955), who showed that it depended both on thick fur or feathers over the body and on peripheral cooling of the thinly covered legs and other exposed parts. The temperature distribution on the body skin and extremities of various arctic mammals at different temperatures is shown in Figure 4. Warm skin is dependent on a temperature drop through the fur; this phenomena has been described for certain arctic mammals by Griffin et al. (1953). An example of such a temperature gradient measured by thermocouples placed in parallel at various depths is shown in Figure 5.

In thinly fur-covered legs, tissues replace fur as insulators. Heat exchangers are possibly located in the area of the base of the limbs, which show a sharp temperature drop. Such heat exchangers have been demonstrated in tropical sloths (Choloepus hoffmanni and Bradypus griseus) by Scholander (1957) and may occur widely in furred mammals (Scholander, 1955). However, the presence of a marked temperature drop in a limb or appendage does not necessarily signify the presence of a heat exchanger.

The cooling of peripheral tissues, which suggests tolerance to cold not shared by warm tissues, is one of the remarkable properties of homeotherms. The demonstration of functional differences between cool and warm tissues is difficult, although suggestive evidence has been found in the distribution of fats of lower melting point associated with low temperature function. Irving, Schmidt-Nielsen, and Abramsen (1957) have shown that the distribution of low melting point fats in various animals is not related to the climate in which the animals live. Other adaptations to cooling in peripheral tissues have been demonstrated by Chatfield et al. (1953) in the ability of the leg nerve of the herring gull (Larus argentatus) to conduct at lower temperatures in distal than in proximal parts of the nerve, and by Heroux (1959) in a capability of the ears of rats to recover from non-freezing cold injury (Rattus norvegicus) during prolonged cold exposure. Nevertheless, the pronounced retardation

MAMMALIAN COLD ACCLIMATION

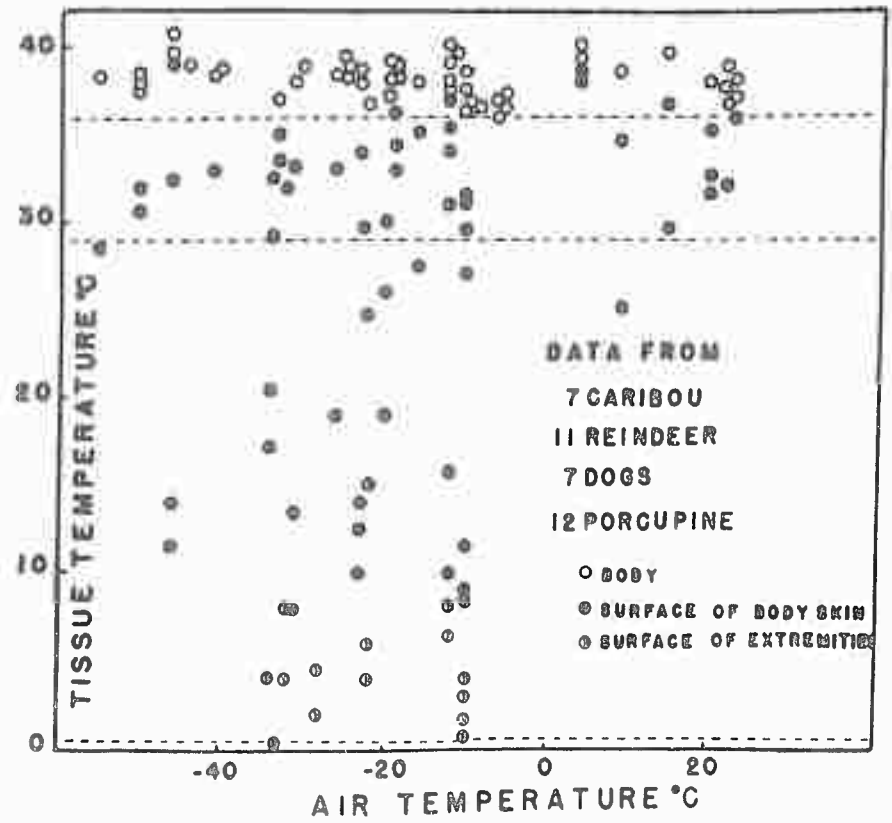

Figure 4. Combined presentation of temperature measurements in 37 individuals of 4 species of mammals adapted to arctic life. From Irving and Krog, 1955.

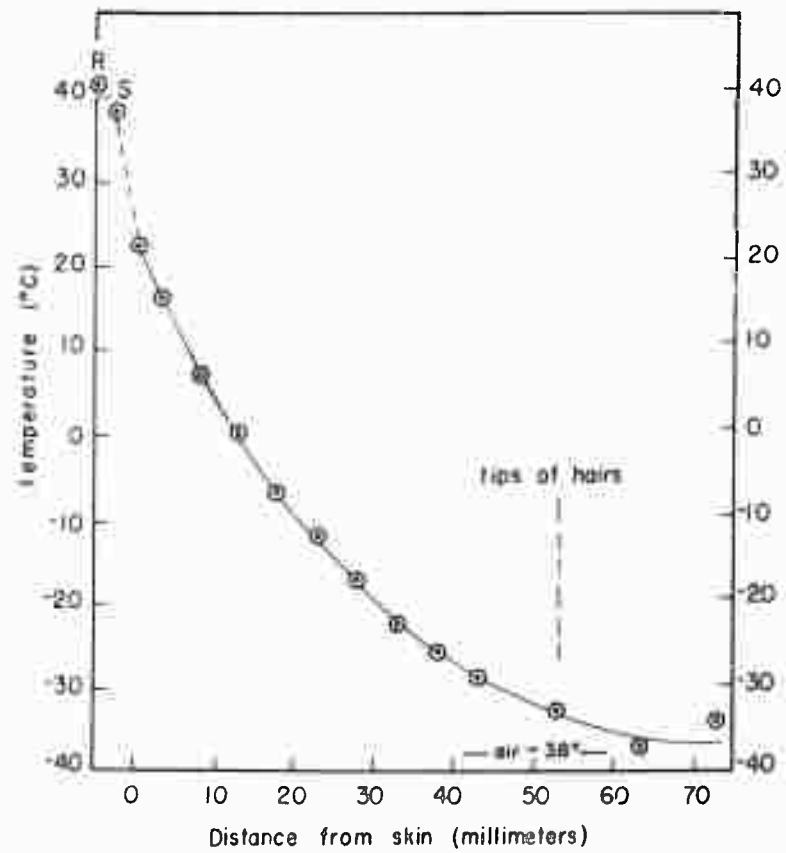

Figure 5. Temperature gradient through fur of a sled dog thoroughly acclimatized to the cold. R and S are rectal and subcutaneous temperatures. Each point is the average of readings 10 to 20 minutes after insertion of gradiometer from Griffin et al., 1953.

MAMMALIAN COLD ACCLIMATION

of functional activity of cool tissues is one of the puzzling phenomena of homeotherms which must be active at all temperatures. Functional retardation by cold, at least for growth processes, has recently been demonstrated by Heroux (1960), who showed that the mitotic activity decreased about 10-fold for a 10 degree lowering of temperature in the skin of the rat.

While large adult arctic mammals are apparently able to withstand the most severe cold with little or no elevation of metabolic rate, such may not be true for infant animals of the same species. Baby caribou (Rangifer arcticus) born during June in the far north are exposed to cold, wind, and precipitation that may lead to mortality (Hart et al., 1962c). These calves are extremely sensitive to cold, as shown by the marked elevation in metabolism resulting from exposure to the harsh environmental conditions (Figure 6). In contrast, a 9-month calf of the same litter did not show elevation of metabolism at temperatures down to -50° C.

Seasonal changes in some northern mammals have been shown by Irving, Krog, and Monson (1955) for the porcupine (Erethizon dorsatum myops) and red fox (Vulpes vulpes alascensis), but not for the smaller red squirrel (Tamiasciurus hudsonicus preblei). The winter fox and porcupine had lower critical temperatures and would require a much lower temperature than summer animals for the same metabolic response. These comparisons made in a review by Hart (1957) also showed a similar trend for the lemming (Dicrostonyx groenlandicus) when Alaskan (winter) and Ottawa (summer) test animals were considered. It was also pointed out that no changes in the slopes of temperature-metabolism curves were found for the deer mouse (Peromyscus maniculatus gracilis). In this species, winter animals were able to resist lower temperatures (Hart and Heroux, 1953) mainly by metabolic compensation, although some indication of a small increase in insulation of winter animals was observed.

The seasonal changes in these mammals are in line with the seasonal changes in pelage insulation observed by Hart (1956), who demonstrated the obvious fact that smaller mammals with body weights below about 100 gm, unlike the larger ones, fail to achieve significant protection through increased fur thickness during the

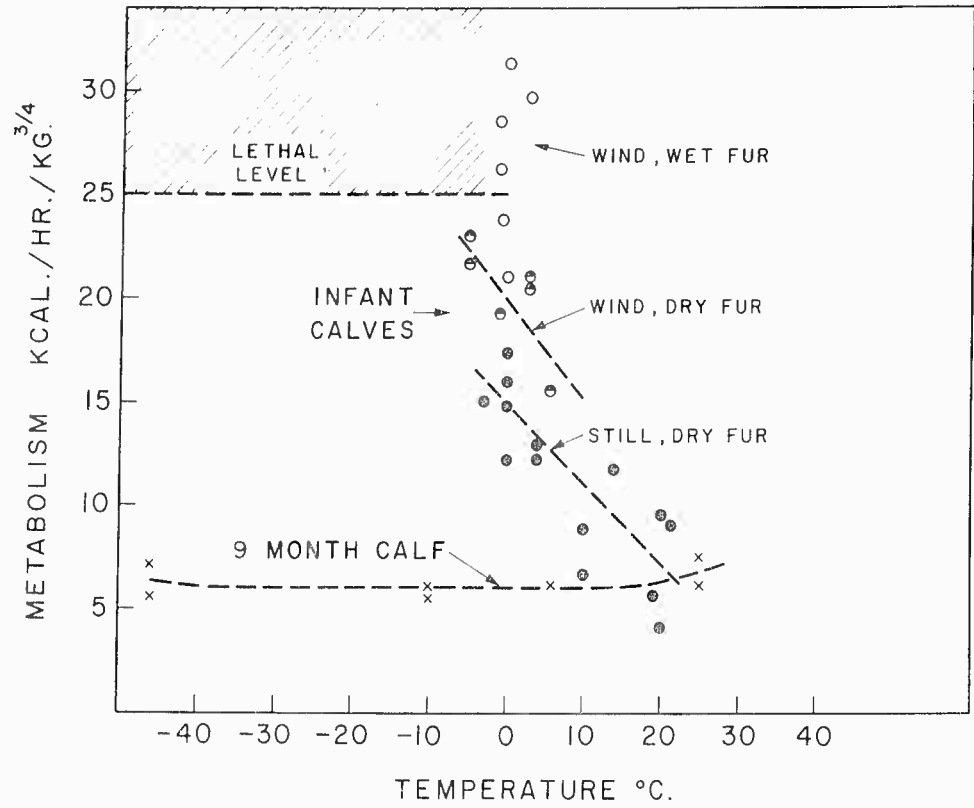

Figure 6. Heat production as a function of environmental temperature in nine-month calf (X) and infant calves in still air with dry fur (●), wind with dry fur (⊙) and wind with wet fur (○). The shaded area and broken line indicate lethal level for prolonged exposure. From Hart 1962c, in press.

MAMMALIAN COLD ACCLIMATION

winter. Consequently they must rely for protection on nest building, huddling, and other devices as shown by Sealander (1952), Pearson (1960), and Barnett (1956). Microclimatic observations by Pruitt (1957) in Alaska have shown that the environment of the boreal red back voles (Clethrionomys rutilus) 3-9 inches below the moss surface ranges for the most part between -5° and $+2^{\circ}$ C when the air temperature falls to -40° C and below. Nevertheless, temperatures in this range are well below the thermoneutral range of most small mammals as shown by Hart (1953), Kalabukhov (1940), Morrison and Ryser (1951), Morrison, Ryser, and Dawe (1959), Pearson (1960), Smirnov (1958), and various other workers, suggesting that metabolic compensation is necessary to maintain homeothermy under these conditions. Evidently the protection afforded to Peromyscus maniculatus during the winter in the Ottawa area is likewise insufficient to prevent cold exposure since metabolic acclimatization to winter conditions was pronounced (Hart and Heroux, 1953). Unpublished observations of Hart and Heroux have likewise shown seasonal metabolic acclimatization in wild dump rats, and similar observations have been made on short tailed shrews. Details of the seasonal metabolic changes in rats reviewed by Hart (1962b) are beyond the scope of this review.

Semi-aquatic Fur Bearers

Certain fur bearing mammals such as beaver, otter, and muskrats are dependent on an aquatic environment for their food and shelter, but spend only a small portion of their total life in the water. These mammals are protected from the cooling effect of the water by a layer of air trapped in the fur. In general, very little is known concerning temperature regulation in this group of mammals. However, observations of the author (Hart, 1962a) on muskrats (Ondatra zibethicus) in air and in water illustrate some of the problems in the temperature regulation of a semi-aquatic mammal.

Muskrats tested in air at various temperatures for about 1 hour showed an increased heat production at temperatures below a critical level of approximately 10° C and a gradual lowering of body temperature which became pronounced below -40° C (Figure 7). No appreciable seasonal changes were observed.

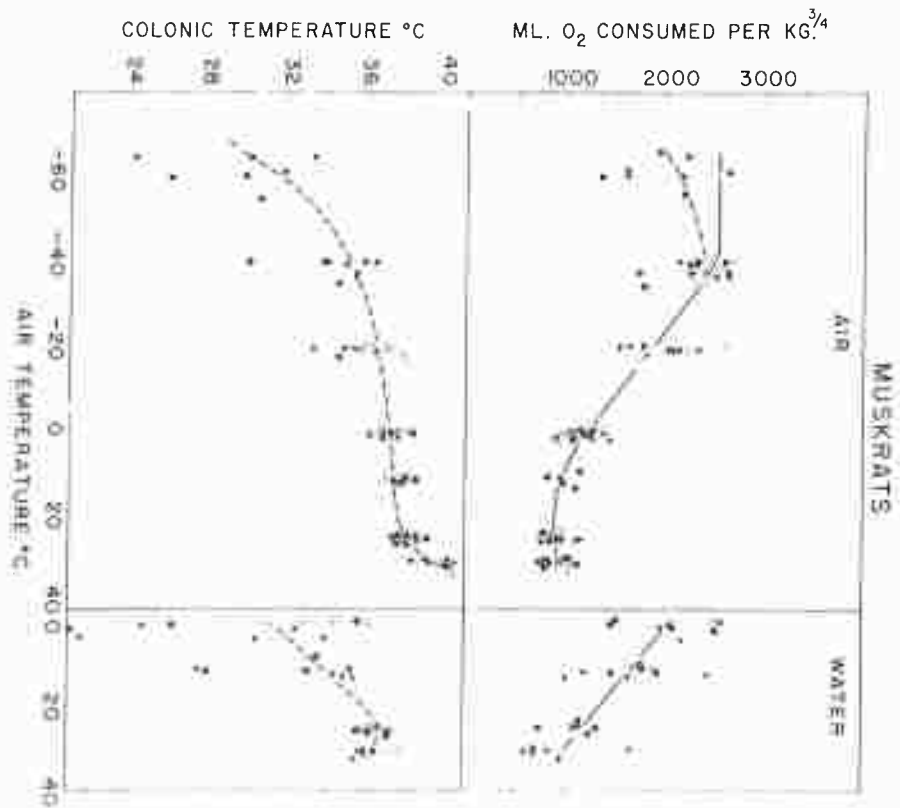

Figure 7. Oxygen consumption and body temperature in muskrats in response to air and water temperatures. Summer animals are indicated by (●) and winter by (○). From Hart, 1962, in press).

MAMMALIAN COLD ACCLIMATION

Oxygen consumption and body temperatures of animals placed in a small tank of water for about three fourths of an hour increased progressively with lowering of water temperature below a critical level of about 30°C . Colonic temperatures fell after the animals were in water at all temperatures below about 20°C . During both summer and winter, it was apparent that the heat production was inadequate to offset hypothermia for prolonged periods at winter temperatures around 0°C . Skin temperatures measured under the fur confirmed the presence of an air layer, because a gradient of approximately 7°C was maintained in the fur at a water temperature of 0°C . Nevertheless, this air was insufficient to prevent generalized cooling. Since the animals were all healthy, muskrats in nature may tolerate limited hypothermia during winter while under the ice and may limit exposure to cold water to shorter excursions than the test exposures in these experiments.

Bare Skinned and Aquatic Mammals

Metabolic studies have been carried out by Irving and coworkers on swine in Alaska (1956) and on seals of the Atlantic coast (1957, 1959). Swine and aquatic mammals will be considered together in this section because of similarities in problems of temperature regulation associated with the presence of a minimal fur cover and an insulating subcutaneous layer of fat or blubber.

Both the swine at various air temperatures (Figure 8) and the harbor seals (*Phoca vitulina*) in air and in water (Figure 9) showed marked temperature gradients through the tissues which were characteristic of the insulating layers of fat and the different outside cooling effects. The distributions of surface temperatures on the body surfaces of swine and seals were also rather similar at comparable air temperatures, indicating similarity in physiological insulation by cooling in these two animals. The critical temperatures for increase in metabolic rate (about 0°C) were also comparable in Alaska swine and harbor seals during the summer.

In water, the surface temperatures of harbor seals were, as anticipated, only slightly greater than ambient, and the critical temperature was elevated from approximately 0°C to 20°C (Figure 10).

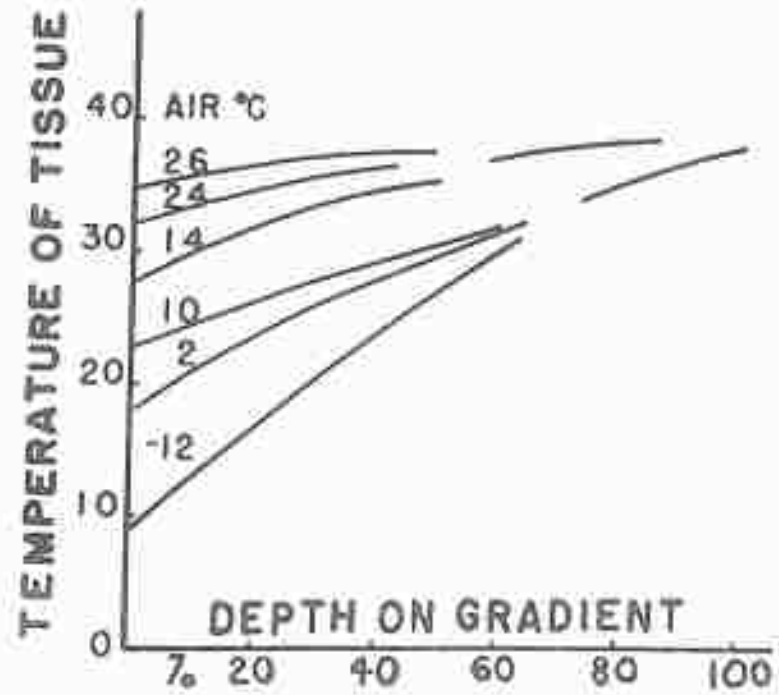

Figure 8. Typical temperature gradients through superficial layers of the swine in air at several temperatures from February to August. Because of seasonal changes in depth of gradient, the scale of the abscissa is observed temperature in tissues body temperature in $^{\circ}\text{C} \times 100$. Data from Irving, 1956.

MAMMALIAN COLD ACCLIMATION

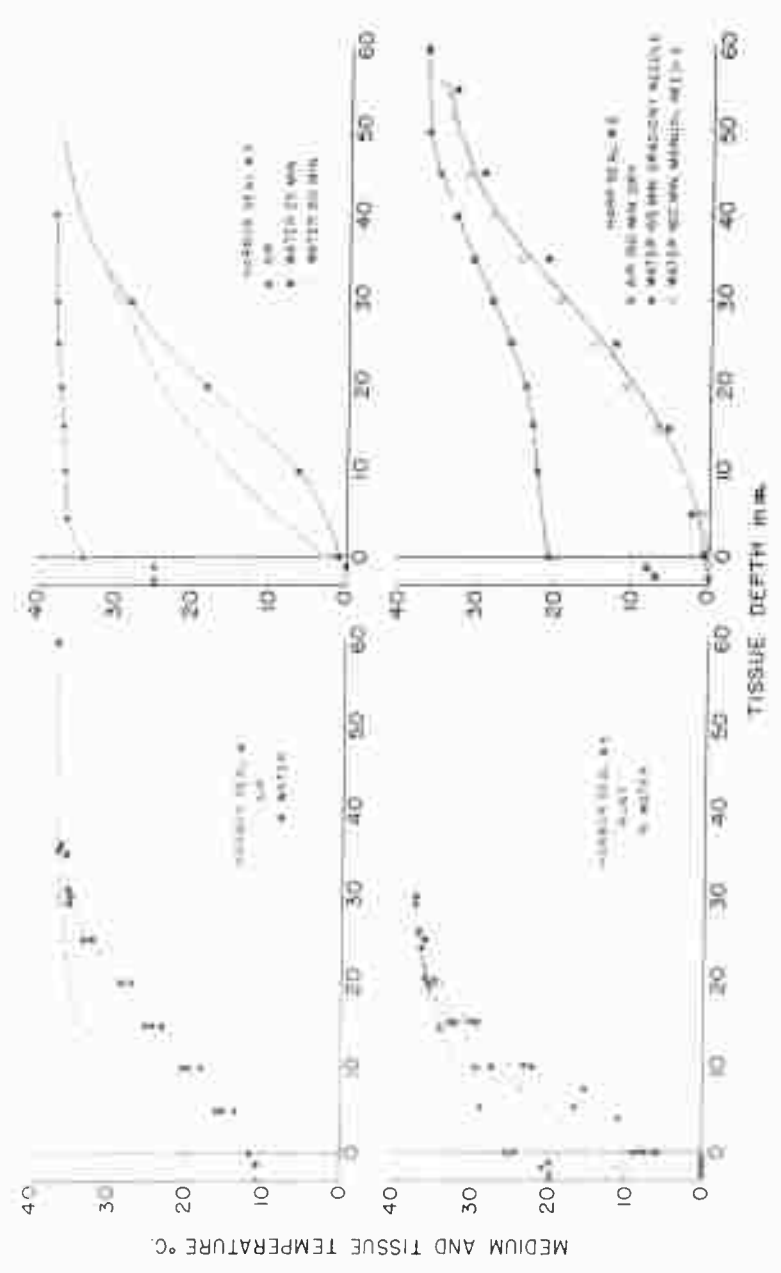

Figure 9. Temperature gradients in the bodies of seals at various air and water temperatures. Ordinates give both medium temperature (outer line) and tissue temperature (inner line). Results from Irving and Hart, 1957.

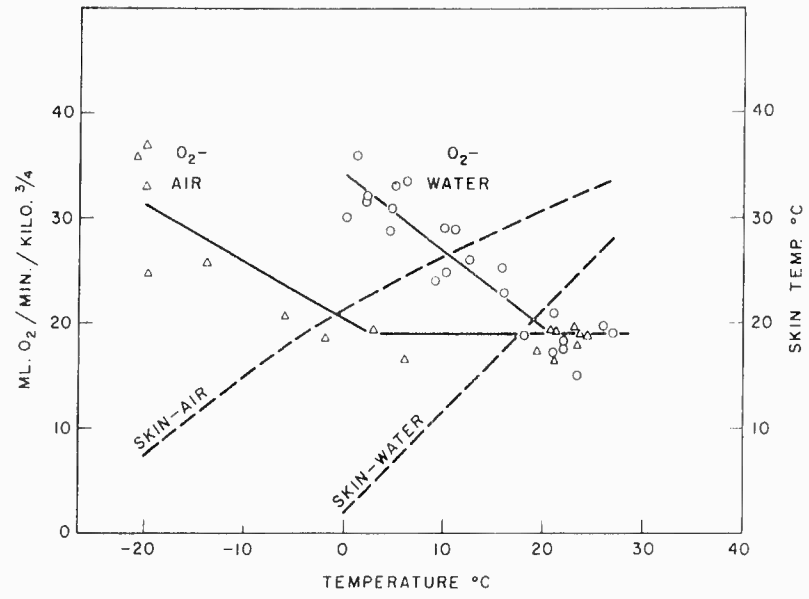

Figure 10. Oxygen consumption of seals in the air (Δ) and in water (O) at different temperatures during the summer. Body skin temperatures as a function of temperature of the medium are also shown. Results from Hart and Irving, 1959.

MAMMALIAN COLD ACCLIMATION

This represents a difference of about twenty-fold in the cooling effect of air and water, but the total insulation (body + medium) in water was about 50% of its value in air. It can be noted that the metabolic response closely parallels the skin cooling in air and water.

The parallel between peripheral cooling and metabolic response was also seen between different seals and was reflected in the individual variability (Irving and Hart, 1957) (Figure 7). The smallest seal, characterized as the "runt," had a very thin layer of blubber and consequently was unable to maintain a surface temperature lower than 6° C to 8° C when in water at 0° C. The high heat flow resulted in a high oxygen consumption at all temperatures. In other harbor seals with a considerably deeper and less steep gradient through the thicker blubber, there was a much lower surface temperature and a maintenance of resting metabolism down to a critical level of about 10° C. However, a harp seal (*Phoca groenlandica*), with a still deeper gradient and a lower surface temperature, was able to compensate completely without elevation of metabolism even in ice water. This represents the greatest cooling load experienced by mammals in nature and the harp seal has the greatest physiological insulation known for mammals.

Harbor seals tested in December at St. Andrews, N. B., and at Woods Hole, Massachusetts, during the summer revealed seasonal changes that were comparable to those found by Irving, Krog, and Monson (1955) for the red fox and the porcupine. During the summer there was a greater elevation of oxygen consumption in cold water than during the winter and the critical temperature was raised from about 11° C to 20° C in water. There was, therefore, a greater physiological insulation in winter than in summer; this was associated with changes in peripheral tissues. No anatomical basis for this change was noted. The nature of the seasonal alteration was such that the differences were observed even at the same body skin temperature (Figure 11). This puzzling phenomenon suggests that more heat is lost in summer than in winter at the same body skin temperature. This could be accounted for by a greater evaporative heat loss from the lungs or by a greater heat loss from the appendages, neither of which were measured in this investigation.

HART

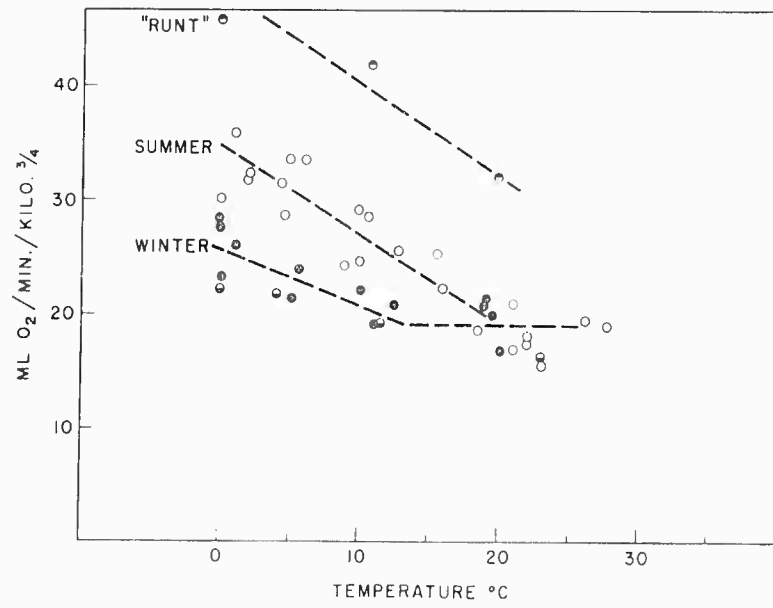

Figure 11. Oxygen consumption as a function of body-skin temperature for seals during winter (▲●) and summer (▲○) in air (▲▲) and in water (●○). Results from Hart and Irving, 1966.

MAMMALIAN COLD ACCLIMATION

While the temperature of the body skin was uniformly related to the water temperature, temperatures of the appendages showed striking fluctuations, suggesting independent control of heat loss, which might be a basis for seasonal differences. The nature of the fluctuations in temperature of the flippers was consistent with the view that control of peripheral heat loss was affected by the presence of vascular heat exchangers, such as those described by Scholander and Schevill (1955) for porpoises (Lagenorhynchus acutus and Tursiops truncatus).

Comparison of Different Species

Metabolic response to cold versus skin temperature. It is difficult to compare the metabolic responses of species which live in such different media as air and water. One basis is to make the comparisons relative to the actual body skin temperature of the species in question. This has the merit of relating the response to some aspect of the animals' own perception system to which it must be responding rather than to some physical aspect of the environment. The use of skin temperature is disadvantageous because it is highly variable and is known only for a few species. Skin temperatures measured over the mid part of the body on the flank or back of a series of animals are correlated with oxygen consumption in Figure 12, as originally shown by Hart (1962b). The sources of the data are indicated in the legend. Comparisons of the same species relative to air temperature are also shown.

Clearly, the various species are distributed in a series with respect to the sensitivity of the skin as a factor in the metabolic response to cold. All the land mammals tested show increased heat production at relatively high skin temperatures. Next in order is the semi-aquatic muskrat, followed by the swine. The cooling of the muskrat skin for the same metabolic response is not as great as that for the harbor seal, especially during the winter. The least sensitive species was the harp seal, which showed no increase in metabolism even in ice water. The range of responses indicates the very great species differences that exist in toleration of peripheral cooling and in temperature range of peripheral stimuli required to illicit that response. It has also been shown for the harbor seal and for the leg

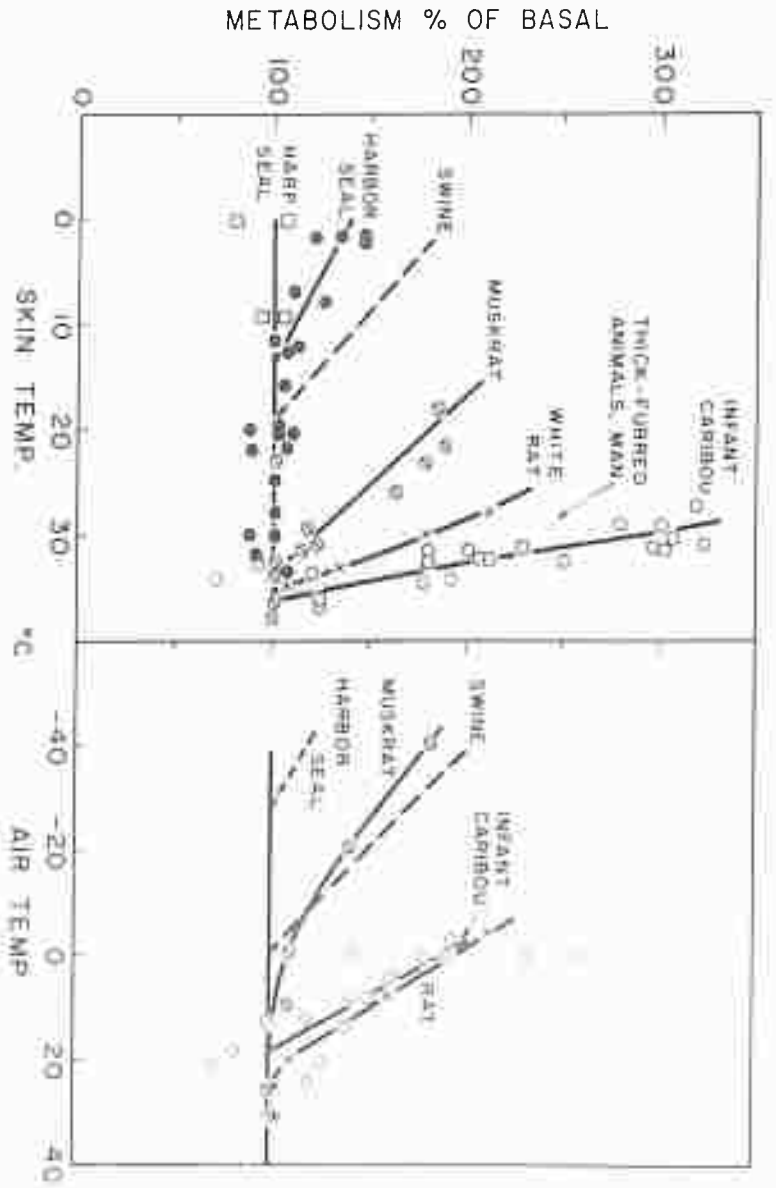

Figure 12. Metabolism, expressed as percentage of increase over the resting or basal value, versus skin temperature (left) and air temperature (right) for harp and harbor seals (Irving and Hart, 1957), swine (Irving, 1956), muskrat (Hart, 1962a), white rat (Heroux, unpublished), and infant caribou (Hart et al., 1962). Individual values given for seals and caribou, group means for muskrat, trend lines (broken curve) given for data on swine. Broken curve for harbor seal in air is an estimate from skin temperatures in water. From Hart, 1962c.

MAMMALIAN COLD ACCLIMATION

nerve of the herring gull that these responses may be altered by acclimatization in the same species.

The comparisons in Figure 12 also illustrate the fact that the metabolic sensitivity to cold may differ, depending on whether the oxygen consumption is correlated with skin or with air temperature, e. g., swine and muskrat. This is because the fur provides the insulation for the muskrat but not for the swine. Similarly, the thick furred arctic mammals with warm skin may be as sensitive to lowered skin temperatures as the rat, caribou, and man, even though the most severe arctic conditions can be withstood without elevation of resting heat production (Scholander et al., 1950a). Therefore, arctic and tropical mammals may be quite similar with regard to the skin cooling required for a given metabolic response.

Metabolic response to cold in relation to body size and insulation of the fur. A summary of data published in the fourth Temperature Symposium of the American Institute of Physics (Hart 1962b) is illustrated in graphic form in Figure 13. The slope of the temperature-metabolism curve below the critical level is given as the ratio of the temperature drop to the increase in metabolism, which is dimensionally comparable to an insulation rather than a conductivity function. This is done to facilitate comparison of slopes with fur insulation (open circles) for the few species for which data are available.

It may be seen that the slope tends to increase with increase in body weight, but that there is an enormous increase in species variability with increase in weight. This is because the small mammals are all metabolically sensitive to cold while the large mammals may be sensitive or insensitive. The least sensitive are the arctic mammals with thick fur which give the three highest values for slope, e. g., snow-shoe hare in winter, red fox, and white fox. The larger mammals may also have little fur and lower values for slope, e. g., dog, harbor seal in summer, and Brahman bull.

When slope is related to insulation of the fur (broken line), there appears to be a much closer correlation. However, it is obvious that the same correlation would not be applicable for either bare-skinned or aquatic mammals with subcutaneous fat and a thin fur cover. The

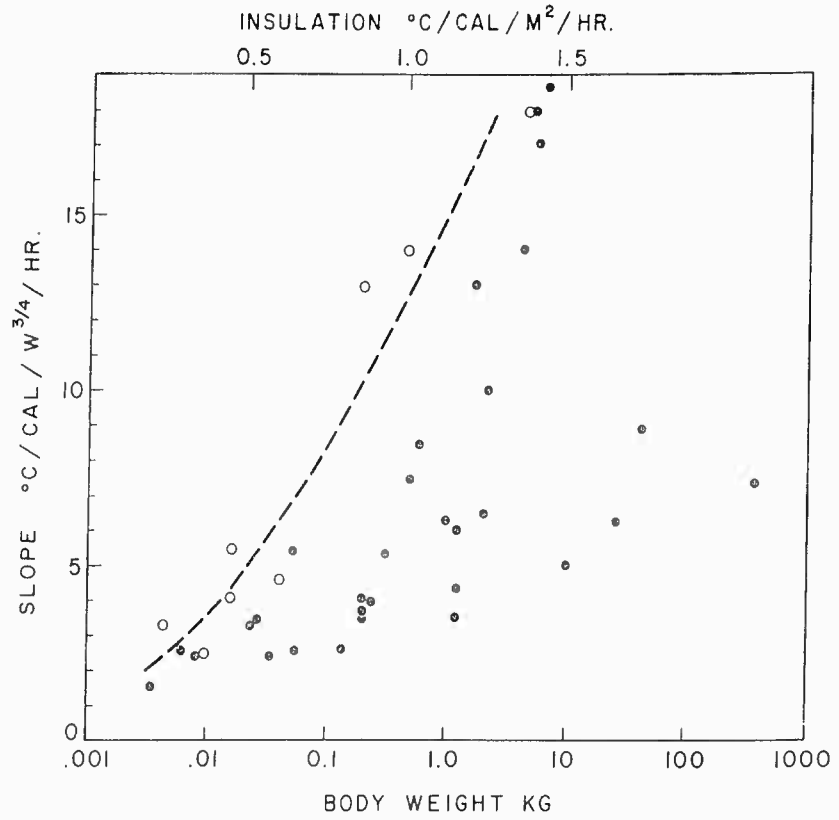

Figure 13. Overall body insulation (●) expressed as the slope of the temperature-metabolism curve below the thermoneutral range ($^{\circ}\text{C}/\text{cal}/\text{body weight}^{3/4}/\text{hr}$) in relation to body weight, and slope (○) as a function of pelage insulation (broken line). Data are replotted from table given by Hart 1962b.

MAMMALIAN COLD ACCLIMATION

correlation may be applicable to most fur bearers, but information at present is inadequate.

SUMMARY AND CONCLUSIONS

The temperature regulation and adaptation of mammals to cold climates follows different patterns in large and small mammals, and in fur-bearing compared to bare-skinned or aquatic mammals. The large arctic mammals with thick fur have a capability for withstanding the severest climatic conditions without elevation of heat production. This is accomplished by considerable cooling of the peripheral areas and appendages as well as by great insulation of the fur. The combined effect of these insulators provides a variable response graded precisely to the temperature of the environment in a way not yet fully understood. Climatic adaptation to arctic and tropical environments as well as acclimatization to summer and winter environments appears to be related to alteration in insulation of the fur rather than to changes in body temperature or in metabolic rate. However, infant animals of arctic species may be very sensitive to temperature.

In the mammals of small body weight, compensation for cold through changes in insulation is not possible, and when protection is inadequate, an elevation of heat production is necessary. Evidence has been presented that small mammals such as mice and wild rats show an increased cold resistance during the winter that is the result of the development of an increased metabolic capacity. It is therefore apparent for the few species studied that cold exposure and elevation of metabolism must have occurred during the winter to account for the development of the observed seasonal acclimatization.

The only fur-bearing semi-aquatic mammal studied (muskrat) showed no evidence of seasonal change even though exposure to water at 0° C during the winter seems inescapable. The surprising feature of the study was the degree of body cooling observed during short term exposure to cold water and the failure of fur insulation and

metabolism to compensate adequately for the observed cooling. It was suggested that mild hypothermia might be tolerated by muskrats in nature.

In swine and in the true aquatic mammals with an insulating layer of blubber, living tissues replace the fur as the effective insulators, and there is pronounced cooling of peripheral tissues. In harbor seals exposed to ice water, there is a reduction of heat production during the winter, signifying a seasonal change in insulation of the living tissues. Arctic harp seals are superior to harbor seals during the winter since they can tolerate ice water without lowering body temperature or elevating heat production.

When the body skin temperature of various species are compared, very large differences are found in the temperatures corresponding to elevation of heat production. In the fur-bearing land mammals studied, heat production increased with only slight skin cooling whereas in aquatic mammals a pronounced skin cooling was necessary. The swine and muskrat were intermediate. The distinction in the metabolic response to cold between land mammals and aquatic mammals is much more apparent with respect to skin temperature than to air temperature.

The metabolic response to cold in different non-aquatic species is related both to insulation of the fur and to body size. However, while small mammals with thin fur are metabolically sensitive to cold, large mammals may be sensitive or insensitive, depending on the fur insulation. In aquatic mammals so far studied the fur insulation was negligible and hence did not affect the metabolic response to cold. Temperature regulation in aquatic mammals is effected through physical regulation of heat loss in the general body surface and particularly in the appendages.

MAMMALIAN COLD ACCLIMATION

LITERATURE CITED

1. Barnett, S. A. 1956. Endothermy and ectothermy in mice at -3°
C. J. Exp. Biol. 33:124.
2. Burton, A. C. and O. G. Edholm. 1955. Man in a cold environ-
ment. Edward Arnold, London.
3. Carlson, L. D. 1954. Man in cold environment, a study in physi-
ology, Alaskan Air Command, Arctic Aeromedical Labora-
tory. U. S. Dept. Commerce, Office of Technical Services P.
B. report 111716, Washington.
4. Chatfield, P. O., C. P. Lyman, and L. Irving. 1953. Physiological
adaptation to cold of peripheral nerve in the leg of the herring
gull (Larus argentatus). Am. J. Physiol. 172:639.
5. Griffin, D. R., H. T. Hammel, H. M. Johnson, and K. S. Lawson.
1953. The comparative physiology of thermal insulation. Final
Rept. Contract 33 (038)-12764 between US Air Force and Cor-
nell University.
6. Hart, J. S. 1953. Energy metabolism of the white footed mouse,
Peromyscus leucopus novaboracensis after acclimation at
various environmental temperatures. Can. J. Zool. 31:99.
7. Hart, J. S. 1956. Seasonal changes in insulation of the fur. Can.
J. Zool. 34:53.
8. Hart, J. S. 1958. Metabolic alterations during chronic exposure
to cold. Fed. Proc. 17:1045.
9. Hart, J. S. 1957. Climatic and temperature induced changes in the
energetics of homeotherms. Revue Can. de Biol. 18:133.

HART

10. Hart, J. S. 1962a. Seasonal changes in wild rats and muskrats. *Can. J. Zool.*, in press.
11. Hart, J. S. 1962b. Physiological adjustments to cold in non-hibernating homeotherms. Proc. 4th Temp. Symposium. Am. Inst. Physics, Columbus, Ohio, in press.
12. Hart, J. S. 1962c. The influence of climate on metabolic and thermal responses of infant caribou. *Can. J. Zool.*, in press.
13. Hart, J. S. and O. Heroux. 1953. A comparison of some seasonal and temperature-induced changes in Peromyscus: Cold resistance, metabolism and pelage insulation. *Can. J. Zool.* 31:528.
14. Hart, J. S. and L. Irving. 1959. The energetics of harbor seals in air and in water with special consideration of seasonal changes. *Can. J. Zool.* 37:447.
15. Heroux, O. 1959. Histological evidence for cellular adaptation to non-freezing cold injury. *Can. J. Biochem. Physiol.* 37:811.
16. Heroux, O. 1960. Mitotic rate in the epidermis of warm- and cold-acclimated rats. *Can. J. Biochem. Physiol.* 38:135.
17. Irving, L. 1956. Physiological insulation of swine as bare-skinned mammals. *J. Appl. Physiol.* 9:414.
18. Irving, L. and J. S. Hart. 1957. The metabolism and insulation of seals as bare-skinned mammals in cold water. *Can. J. Zool.* 35:497.
19. Irving, L. and J. Krog. 1955. Temperature of skin in the arctic as a regulator of heat. *J. Appl. Physiol.* 7:355-364.
20. Irving, L., H. Krog, and M. M. Nielsen. 1955. The metabolism of some Alaskan animals in winter and summer. *Physiol. Zool.* 28:173.

MAMMALIAN COLD ACCLIMATION

21. Irving, L., L. J. Peyton, and M. Monson. 1956. Metabolism and insulation of swine as bare-skinned mammals. *J. Appl. Physiol.* 9:421.
22. Irving, L., K. Schmidt-Nielsen, and N. S. B. Abramsen. 1957. On the melting point of animal fats in cold climates. *Physiol. Zool.* 30:93.
23. Kalabukhov, N. I. 1940. Influence of temperature upon oxygen consumption by wood-mouse (*Apodemus silvaticus*) and yellow-necked mice (*Apodemus flavicollis*). *Compt. rend. (Doklady) de l'acad. Sci. de l'URSS.* N. S. 26:89.
24. Morrison, P. R. and F. A. Ryser. 1951. Temperature and metabolism in some Wisconsin mammals. *Fed. Proc.* 10, No. 1.
25. Morrison, P. R., F. A. Ryser, and A. R. Dawe. 1959. Studies on the physiology of the masked shrew. *Physiol. Zool.* 32:256.
26. Ol'nyanskaya, R. D. and A. D. Slonim. 1947. On the adaptability of organisms to very low temperatures of the environment. *Invest. Acad. Nauk. SSSR. Ser. Biol.* 245.
27. Pearson, O. P. 1960. The oxygen consumption and bioenergetics of harvest mice. *Physiol. Zool.* 33:152.
28. Pruitt, W. O. 1957. Observations on the bioclimate of some tundra mammals. *Arctic* 10:131.
29. Scholander, P. F. 1955. Evolution of climatic adaptation in homeotherms. *Evolution* 9:15.
30. Scholander, P. F. 1957. Countercurrent heat exchange and vascular bundles of sloths. *J. Appl. Physiol.* 10:405.
31. Scholander, P. F., R. Hock, V. Walters, F. Johnson, and L. Irving. 1950a. Heat regulation in some arctic and tropical mammals and birds. *Biol. Bull.* 99:237.

HART

32. Scholander, P. F., R. Hock, V. Walters, and L. Irving. 1950b. Adaptation to cold in arctic and tropical mammals and birds in relation to body temperature, insulation and basal metabolic rate. *Biol. Bull.* 99:259.
33. Scholander, P. F., V. Walters, R. Hock, and L. Irving. 1950c. Body insulation of some arctic and tropical mammals and birds. *Biol. Bull.* 99:225.
34. Scholander, P. F. and W. E. Schevill. 1955. Countercurrent vascular heat exchange in the fins of whales. *J. Appl. Physiol.* 8:279.
35. Sealander, J. A. 1952. The relationship of nest protection and huddling to survival of Peromyscus at low temperature. *Ecology* 33:63.
36. Smirnov, P. K. 1958. Characteristics of heat exchange in the harvest mouse, Micromys minutus. Translation of Doklady Acad. Nauk. SSSR in Doklady Biol. Sci. Section 117(4); 717.
37. Symposium sur l'acclimation au froid. 1957. *Rev. Can. de Biol.* 16:133.
38. Symposium in Centre Nationale de la Recherche Scientifique. 1955. *Arch. Sci. Physiol.* 9:C₁-C₂₂₉.
39. Symposium on cold acclimation. 1960. *Fed. Proc.* 19:1.

MAMMALIAN COLD ACCLIMATION

DISCUSSION

MORRISON: I have some data on related species living in the same environment. These show differing thermal sensitivities that can be rather nicely correlated with their habits. I hope this will be of interest because it represents work done with Dr. F. A. Ryser in this laboratory some years ago.

These are simply measurements of the body temperature against the ambient temperature. Figure 14 compares the two common voles taken from the nearby Chena River in February and March. Clethrionomys has excellent regulation. Microtus, on the other hand, falls off badly at low ambient temperatures both in regard to the summer temperature and the higher winter temperature. This correlates with their habits since Microtus stays strictly inside its burrow system when it is cold, whereas Clethrionomys does come out and move around.

Figure 16 compares the two lemmings from the far north. Dicrostonyx regulates well but Lemmus is not so effective. Dicrostonyx is seen above the snow when it is very cold whereas Lemmus carefully restricts himself to his subnivean microclimate. Incidentally, Dr. Hart showed a slide from Dr. Scholander (Hart, Fig. 2) on insulation values in various northern mammals. There the lemmings were grouped, but the two highest values represented Dicrostonyx while the four lower points were for Lemmus, which difference correlates with the physiology and behavior.

HART: How long were the exposures of the Microtus?

MORRISON: These were caged animals living at these low temperatures, so there were a number of hours of exposure, days in some cases.

HART: Continuous exposure?

MORRISON: Yes.

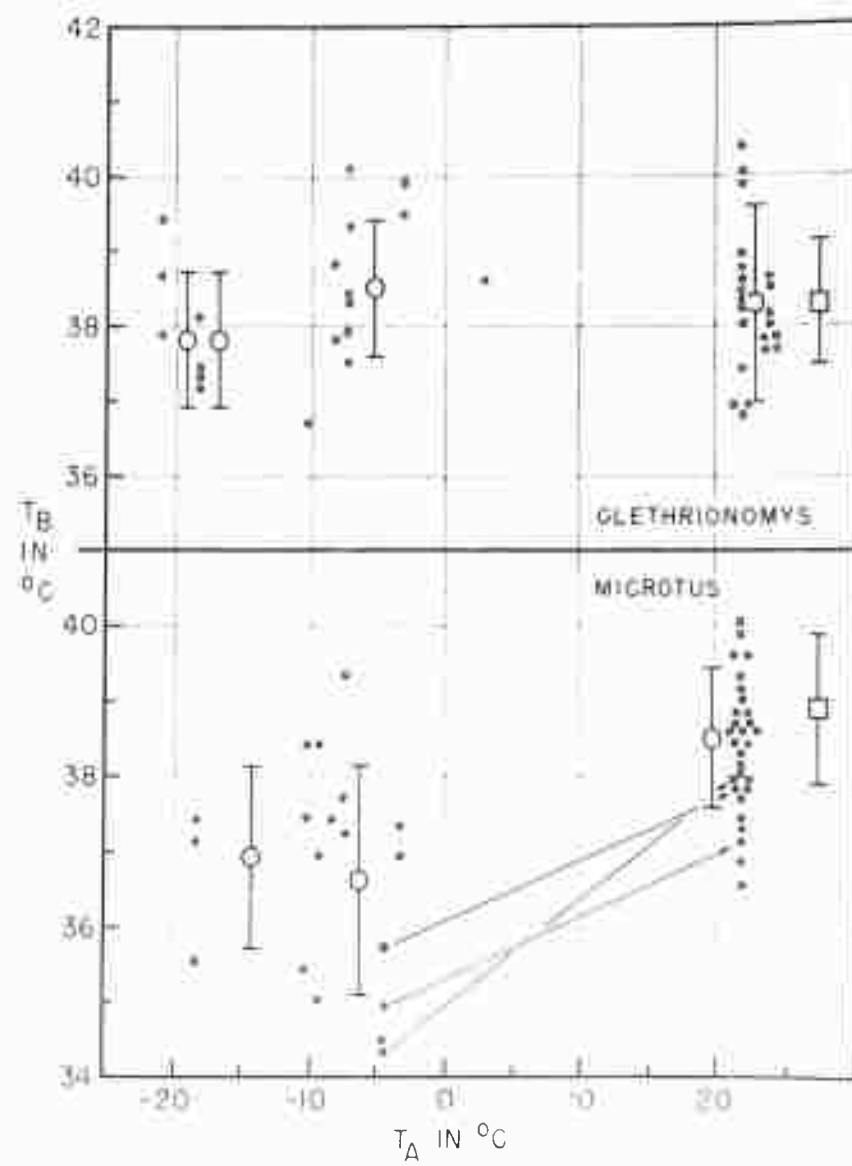

Figure 14. Body temperature in *Clethrionomys* and in *Microtus* as a function of ambient temperature. Circles, winter trapped animals from Fairbanks; squares, summer trapped animals.

MAMMALIAN COLD ACCLIMATION

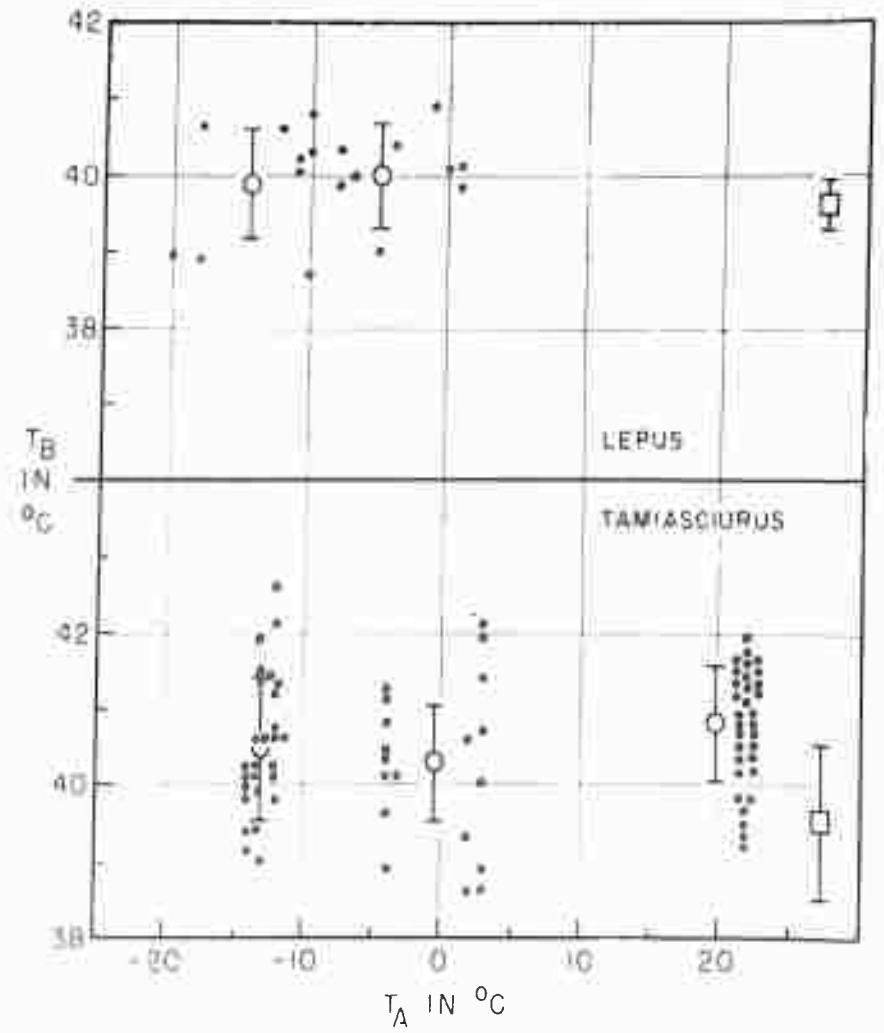

Figure 15. Body temperatures of the snowshoe hare and the red squirrel at various environmental temperatures. Symbols as in Figure 14.

HART

IRVING: They must be able to take quite a lot, because I caught a live Dicrostonyx in March on one of the sand islands off the coast east of Barrow. It was over a mile from shore; we heard him scratching around during the night and he was still alive in the morning. We then traveled about ten miles offshore on the ice and found one Dicrostonyx which had died out there, but it was obviously not killed by, or transported by a predator. I saw the tracks of several others around seven or eight miles from the shore, which must take them quite a long time at their rate of travel.

MORRISON: One of our group tracked a lemming a couple of miles out on the ice off Barter Island. There was no indication of where it was going, but the tracks were in a straight line, not as though it was searching or meandering.

HANNON: With respect to running ability we have observed that the hamster, which is about the same size as the lemming, can run six to eight miles a day--all of this distance being covered entirely during the hours of darkness.

FOLK: The white rat can run 21 miles, so they are capable of running distances, for example one ran 28 miles in 24 hours and another ran 32 miles in 24 hours.

IRVING: But the lemmings were found under conditions where even with their hardiness they were expending metabolic energy at a very rapid rate for maintenance of body temperature.

JOHANSEN: I may perhaps comment on my work on the muskrats. One project was concerned with the fact that the muskrat has a very dense fur and a naked tail, which suggested to me that this tail might have a crucial importance as a heat exchanger; and this turned out to be the case. The tail of the muskrat as it was studied by temperature measurements and plethysmography (where Charles Eagan gave expert help) showed that the tail blood flow can change by a factor more than 400 within a very short

MAMMALIAN COLD ACCLIMATION

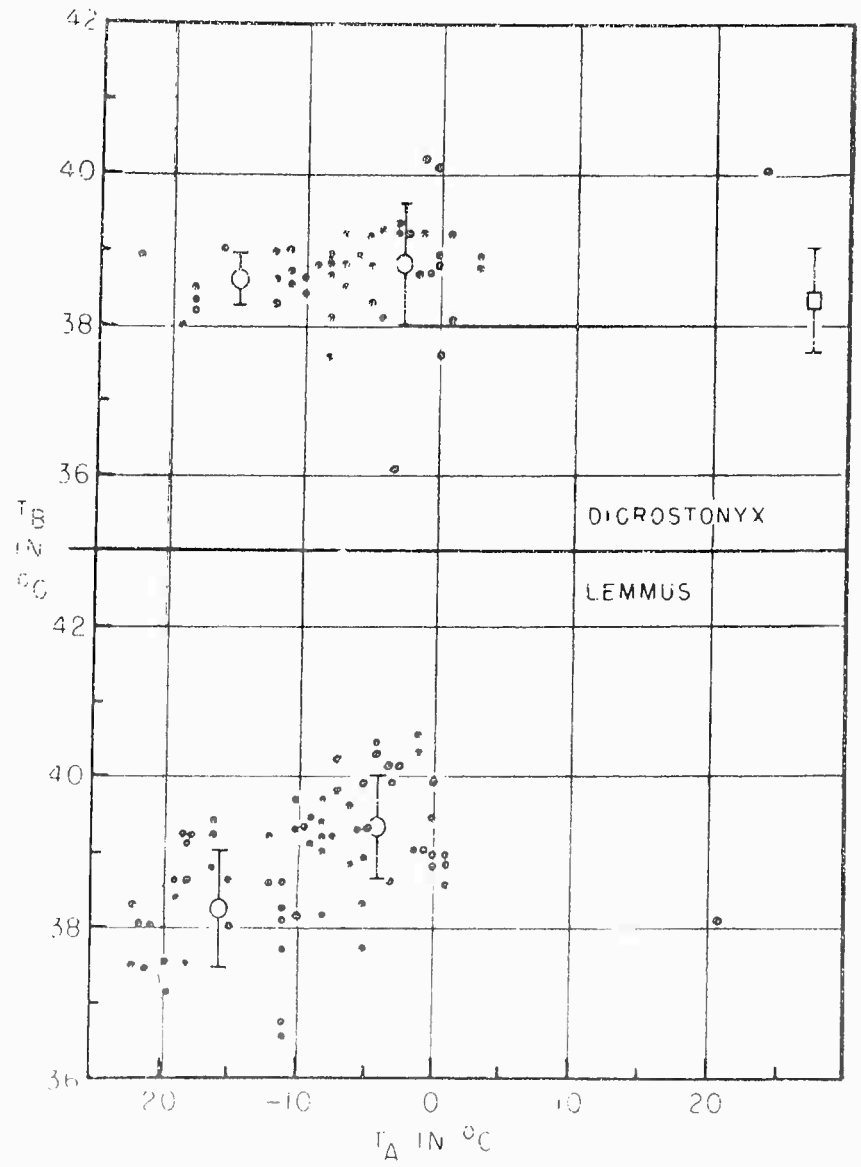

Figure 16. Body temperature in *Dicrostonyx* and in *Lemmus* as a function of air temperature. Symbols as in Figure 14.

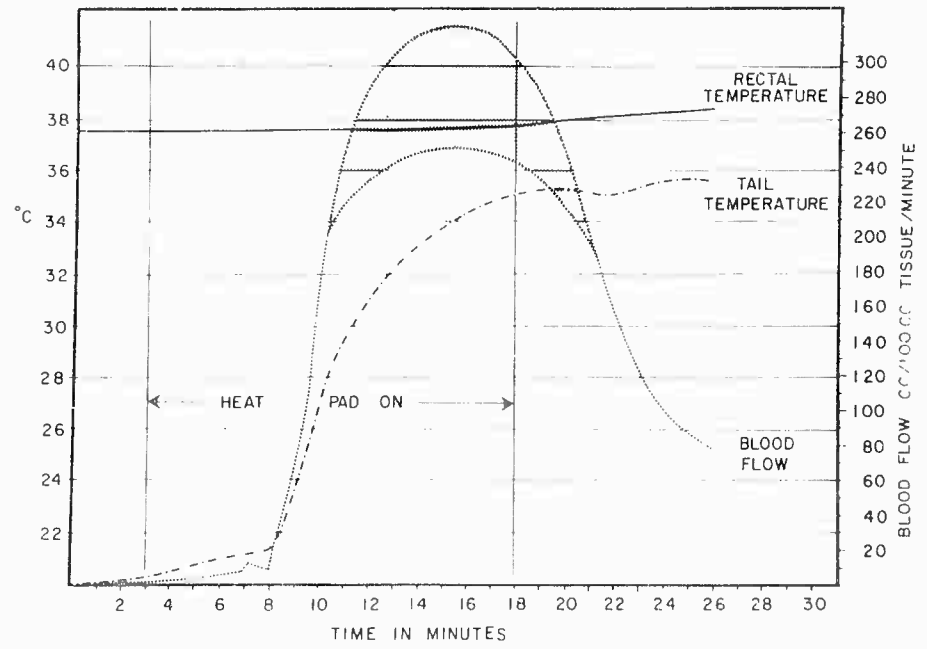

Figure 1. Change in rectal, tail and tail temperatures during immobilization of the animal. Note the dramatic increase in tail blood flow.

MAMMALIAN COLD ACCLIMATION

time (Fig. 18A). If the muskrat is overheated slightly either by exercise or by being exposed to a high environmental temperature, his tail is "flushed" immediately. The skin temperatures are practically as high as the body temperature.

I proceeded by trying to elucidate the mechanisms behind these profound effects and the data acquired from doing nerve blocks of the tail indicate that there exists such a thing as a vasodilator innervation to the skin in the tail of the muskrat. If I nerve-blocked the tail, the animal became hyperthermic in a very short time and in one instance an animal succumbed and died of heat apoplexia when his tail was not intact (Fig 19A).*

In the other project, I tried to assess the importance of the air layer in the fur as an insulator. I compared two groups of animals, one with the air layer intact and one with the air depleted by way of surface active materials, such as detergents. I anesthetized the animals to standardize the condition and to avoid differences in movement. I found that the intact muskrat had a volume of about 800 cc, of which about 200 cc was air. In other words, almost 25% of the volume of the muskrat is air. If these two groups are subjected to water cooling or to air cooling, the temperature drops five times as fast in the one depleted of the air.**

HANNON: There is one question I would like to ask Sandy. In animals such as the muskrat and possibly wild rats living outdoors continuously, do you feel it might be possible for these animals to be continually cold-acclimatized, summer and winter? In the muskrat, for example, in these northern areas, the water is still quite cold in the summer. It may be that they get a level

*Johansen, K. 1962. Heat exchange through the muskrat tail. Evidence for vasodilator nerves to the skin. *Acta Physiologica Scandinavica*. (in press).

**Johansen, K. 1962. Buoyancy and insulation in the muskrat. *J. Mammal.* (in press)

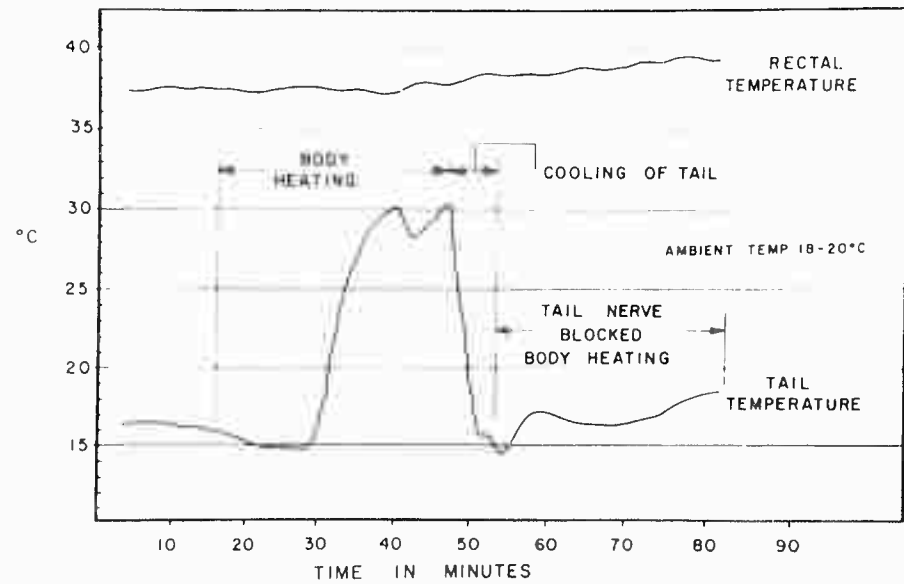

Figure 18. First portion of the figure demonstrates the course of rectal and intracutaneous tail temperature during body heating and consequent vasodilation in a normal undisturbed subject. Subsequently the tail is cooled down, and nerve blocked. Body heating is reapplied but the tail vasodilation and the consequent heat loss is prevented and a rapid increase in rectal temperature is seen.

MAMMALIAN COLD ACCLIMATION

of acclimatization and just maintain it. And that is why you cannot see the difference between summer and winter.

HART: I always think of it as a matter of degree. The muskrat is probably to a certain extent acclimatized in the summer, too, but you would think that they would be more so in the winter.

JOHANSEN: We did some measurements in the field here and the temperatures in the pushups of the muskrats are rather strikingly high during winter. They are from 5°C to 10°C above freezing in the -40°C weather. We do not really know how much time they spend in the cold water; this is what we should find out.

HANNON: You have essentially 0°C water in the winter time, and maybe it will go as high as 15°C in the summer and maybe a little higher. You still have a pretty big differential, but on the other hand they may be a little more active in the summer time in the water, so they get a longer exposure.

HART: It is possible.

IRVING: Dr. Fay has been making some measurements from time to time in the New York Zoo on the temperature on the body skin and flippers of walrus, both young and old. He has been able to get some measurements of wild walrus around St. Lawrence Island, too, and he finds a fair regularity in the relation between the temperature of the skin of the body in air or water. As Hart and I found in harbor seals, the flippers may be quite different from the body and apparently fluctuate as if for fine adjustment of temperatures. Fluctuations in the extremities are also subject to non-thermal excitation, and in absence of obvious relation to heat, are ascribed to plain nervousness.

PROSSER: In your summary slide, comparing the different mammals, you suggested that there might be differences in the sensory sensitivity.

HART: Do you mean sensitivity to skin temperature?

HART

PROSSER: Yes. Is it possible that there might be differences in the endocrine response mechanism?

HART: You might have the same input and a different response to the input.

PROSSER: Have you any evidence about the response of either the thyroid or adrenal in these different series?

HART: Absolutely none.

PROSSER: It seems to me that endocrine response would be an alternate explanation. Of course this could be explored.

EAGAN: However, this endocrine response could be mediated only through the nervous system.

PROSSER: Yes, but the sensory input might be the same.

HART: Is there any way of assessing sensory input in animals? I do not know of any.

PROSSER: It certainly would be worthwhile to try to record the nerve impulses in response to a given cold stimulus.

KLEIBER: I do not think I would be accused of particularly being in love with body surface or against the three-fourths power of body weight. But when you express the specific insulation, I wonder if it would not be wise, for internal consistency, to express the metabolic rate per unit surface, whatever it might be. I mean that you should use weight to the two-thirds power instead of the three-fourths, because otherwise you might introduce a side effect in this insulation which is actually not present.

HART: This is really a measure of metabolism, though.

KLEIBER: Yes, but the metabolism in this case is related to heat exchange and the metabolism related to heat exchange is a

MAMMALIAN COLD ACCLIMATION

function of the surface or is related to surface area rather than to metabolic size.

HART: It might not make too much difference because they are rather close anyway.

KLEIBER: That is right, except when you go from one kilogram to a thousand kilograms.

MORRISON: They are close, but there is a difference between the two functions. In our measurements, taking the thermal conductance from the slopes of the metabolism-ambient temperature curves, a rather elegant relation describes some of the smaller mammals (<500 g). Thus, conductance is equal to the square root of the body weight if the weight is expressed in grams and the conductance in $\text{ccO}_2 (\text{gms} \times \text{hr} \times ^\circ\text{C})^{-1}$.

HART: If you express metabolism as a square root function of body weight, it should then be independent of weight differences.

MORRISON: The exponent will change depending on whether the expression is per gram or per animal. That would change the exponent.

VIERECK: In your figure comparing skin temperatures of different species at different environmental temperatures, where on the animal's body do you take the skin temperature? Do you have any idea of how to get an average skin temperature for the surface?

HART: It was not an average at all. They were simply representative temperatures taken over the trunk of the body.

VIERECK: But the fur is very thick in the back and thin in the front. Where do you take the temperature?

HART: This is underneath the fur, and in the caribou they were averages of several measurements taken on one side of the fur. In the rat measurements were approximately at the same place.

HART

VIERECK: Do you look for a place where the fur is thickest?

HART: Not necessarily.

FOLK: Possibly some experiments will be able to provide the activity of the animal during oxygen consumption. Benedict has stressed this so much. You find two groups of animals in your series, at very cold temperatures where the metabolism is up high. Some of the animals are quite restless and move around, while others curl up and are quiet with high metabolic rates at these cold temperatures.

HART: In those which I have observed, I find almost invariably that they are huddled up and not moving at all. When the cold is such that the metabolic rate is increased close to its maximum, then these animals are seldom if ever moving in my experiments.

FOLK: Can you give examples of animals that were moving under these circumstances? I think of the tropical raccoon. They might be restless, which would account for part of the high metabolism.

HART: Were there not some measurements by Erikson* on ground squirrels which showed a definite correlation of metabolic rate with activity in the cold? In these animals the activity was greatest at the lowest temperatures which increased the oxygen consumption further.

*Erikson, H. 1956. Observations on the metabolism of arctic ground squirrels (*Citellus parryi*) at different environmental temperatures. Acta. Physiol. Scandnav. 27:26-34.

TEMPERATURE RESPONSES AND ADAPTATIONS IN DOMESTIC ANIMALS

Max Kleiber

The body temperature of homeotherms is nearly the same as that of man, about 37°C . Consistent changes from the average do occur, but they are not related to body size or to geographic distribution of the animal. Rat and elephant temperatures are about 1°C cooler than those of man; cow, sheep, and swine, about 1°C hotter, rabbit and dog about 2°C * hotter; and the camel lets its body temperature vary from 34°C to 36°C and seems not to mind a temperature of 40°C if this is necessary for saving water.

Figure 1, somewhat schematized from data of Johnson, et al. (1958) shows that below an environmental temperature of 80°F (27°C), cow and man regulate their body temperatures somewhat more accurately than does the rabbit. Man is much more strict in keeping cool in a hot environment than cow or rabbit. The cow's body temperature rises when the environmental temperature is higher than 80°F (27°C). This is also the case for cold adapted rabbits, whereas rabbits adapted to a warm climate do not raise their body temperatures before the air temperature exceeds 90°F (32°C).

I am not aware of any biological theory which would explain why in the evolution of homeotherms that 36°C to 40°C body temperature has been so much more advantageous than other body temperatures. For all conditions under which homeotherms live and for all their sizes, this thermal level has been fixed by natural selection with a very small variation. It is fixed, however, and so is the basal metabolic rate of homeotherms large and small, tropical and arctic. It can be predicted with about 10% accuracy by the equation:

*Rabbit's normal temperature is 39.6°C ; its variation is generally not more than 1.8°C . Robert C. Lee (1939).

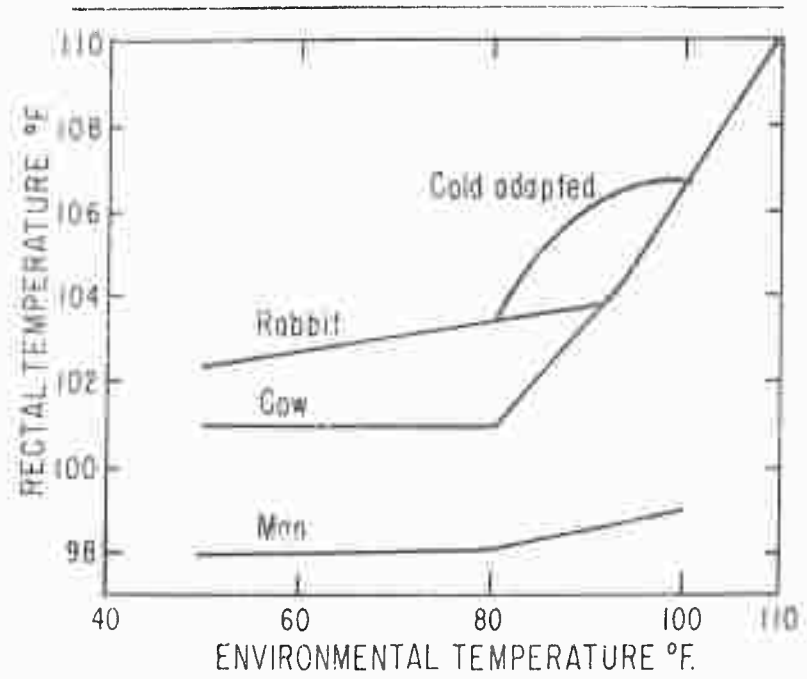

Schematized from H.D. Johnson et al, Mo. Res. Bul. 648 p.18, 1958

Figure 1. Rectal and environmental temperatures of man, cow, and rabbit (cold-adapted and non-cold-adapted).

DOMESTIC MAMMAL ADAPTATIONS

$$B = 70 \times W^{3/4}$$

where B = basal metabolic rate per day in kcal
W = body size in kg (Kleiber, 1947)

Scholander (1955) writes as follows:

The non-adaptability of the resting rate shows that the heat production is not determined by the heat loss as one might infer from the surface law of Rubner (1883) but vice versa. Whatever the surface area happens to be, the heat loss from it must be so regulated by various means that it balances the heat production. In a homeotherm one might say that body temperature plays the first violin, metabolic rate the second, and heat loss the third.

The major, or practically only, adaptation which occurred was the adjustment of the thermal insulation to bring the third violin into harmony with the first and second. This adaptation was accomplished in various ways, and it led to differences in the temperature distribution of various animals.

Figure 2, also schematized from the data of Johnson et al. (1958), shows the skin temperature as a function of the environmental temperature. From 50° F to 90° F (10° C to 32° C) air temperature the rabbit skin maintains an almost constant temperature, whereas the temperature of the skin of cow and man follows the environmental temperature.

This temperature distribution is the result of the high insulating power of the rabbit fur and the fact that man lacks this insulation. The main resistance against heat loss and therefore the greatest temperature gradient in naked man is located in the subcutaneous layer. The cow has a less efficient fur than the rabbit. The difference between rectal temperature and skin temperature, which is an index for the resistance of the subcutaneous layers to heat flow, is shown in Figure 3.

As the environmental temperature rises, the skin temperature of man and cow approaches the rectal temperature but does not reach

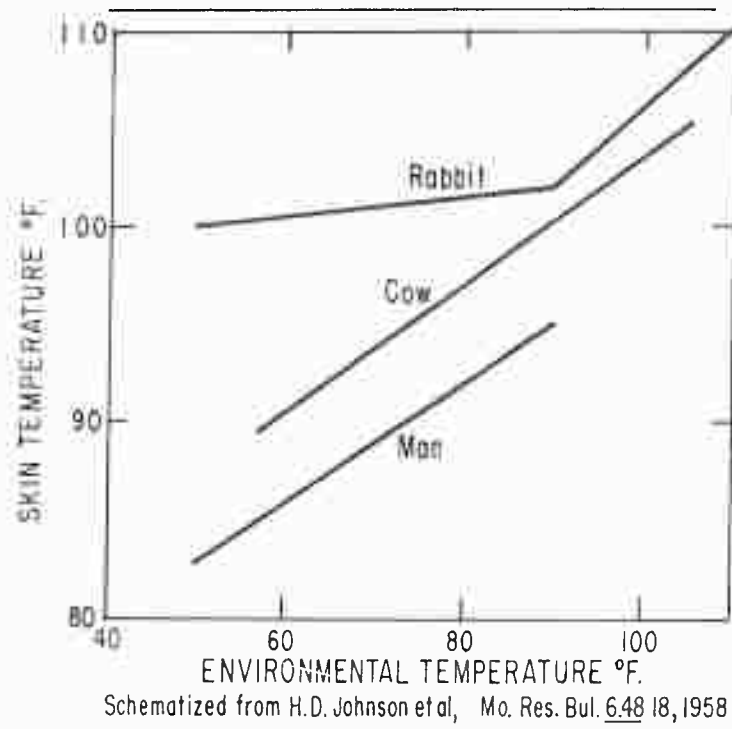

Figure 2. Skin and environmental temperatures of man, cow, and rabbit.

DOMESTIC MAMMAL ADAPTATIONS

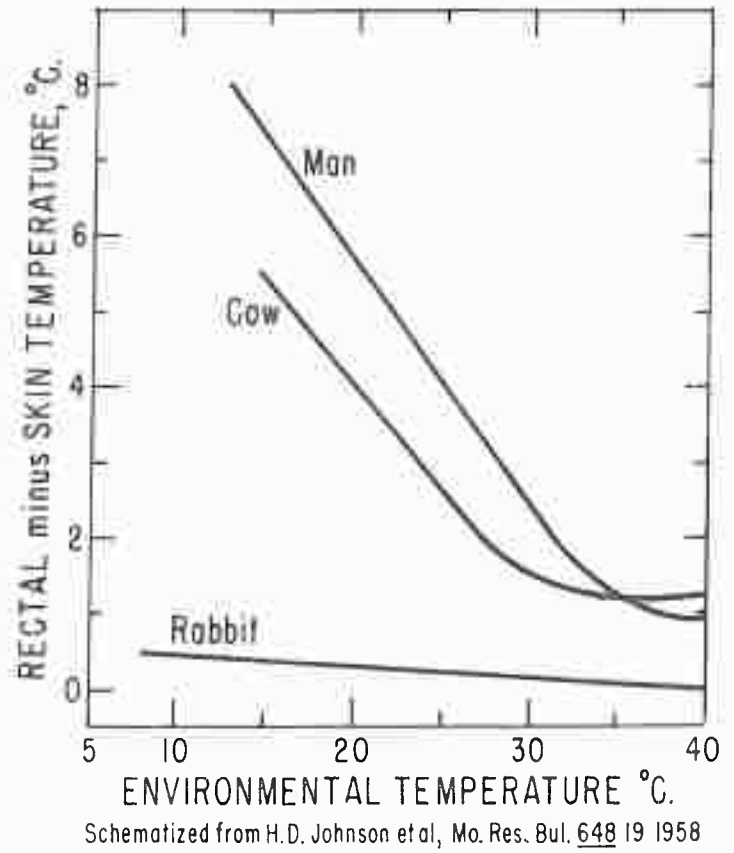

Figure 3. Differences between rectal and skin temperatures in man, cow, and rabbit at various environmental temperatures.

it. When the air temperature rises from 30°C to 40°C , the man and cow maintain an almost constant difference between skin and body temperature. This is mainly the result of evaporative cooling. The rabbit, however, lets his skin temperature almost reach the level of the rectal temperature. Rabbits presumably rely mainly on the evaporative cooling in the respiratory system (or possibly the ear surfaces).

Richet (1889) shaved a rabbit and observed that in this condition the rabbit regulated its body temperature at a lower level. This effect is shown in Figure 4, drawn from data in Richet's book on animal heat.

Diurnal Changes of Body Temperature

Man changes his body temperature during a day in a cyclic fashion, and Kleitman (1951) suggests that differences in this cycle account for differences in the behavior of two types of people, the early risers and the late risers. The late risers are grouchy because their body temperatures are low. They need to be warmed up by a cup of hot coffee to reach a friendly disposition and a positive outlook on life. (See also Kleitman, et al, 1935).

Some domestic animals, such as the donkey and the camel, start their days with a considerably lower body temperature than that of man, and they do not have the benefit of a cup of coffee. They may possibly be endowed with a higher basic level of social grace than man and do not express their grouchy feelings as strongly as some human beings do.

Figure 5 shows the diurnal temperature change of a Holstein cow subjected to an environment simulating the Imperial Valley (Kibler and Brody, 1956). In man, a temperature of 108°F (42°C) would be regarded as a very high fever and the cow's thermostatic capability seems therefore not very impressive: yet comparison of the cow's daily temperature fluctuations with those of the air temperature under actual conditions in the Imperial Valley shows that temperature changes in the body are a small part of those in the

DOMESTIC MAMMAL ADAPTATIONS

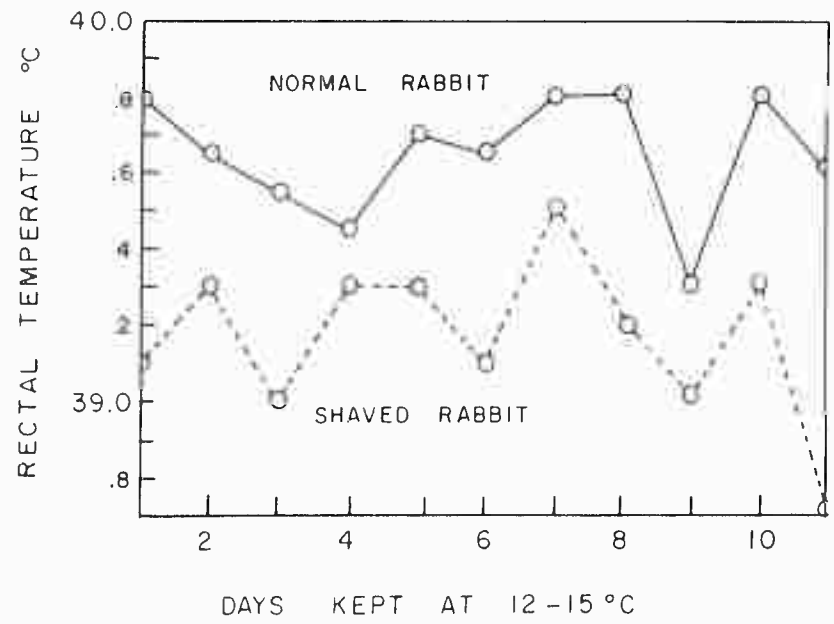
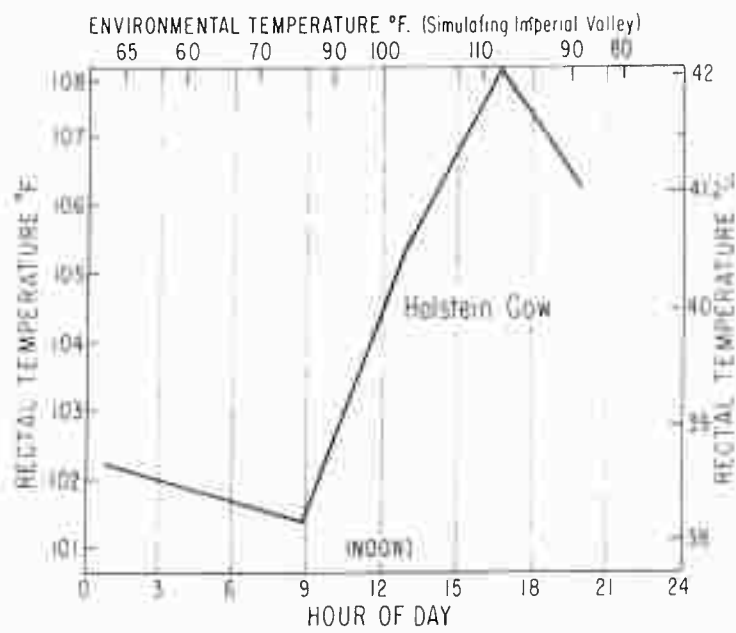

Figure 4. The effect of shaving on the body temperature of rabbits.

KLEIBER



(From H. H. Kibler and S. Brody, Mo. Res. Bul. 601, 10, 1956)

Figure 5. The diurnal change in a cow's body temperature with changes in environmental temperature.

DOMESTIC MAMMAL ADAPTATIONS

environment (Fig. 6). This is especially true in the relatively cool months of May and June. When it gets extremely hot in July and August, the fluctuations of body temperature become greater.

One may define the effectiveness of temperature regulation as the quotient of the change in the environmental temperature and the changes in the body temperature.

Figure 7 shows this calculation for the cow observed by Ittner (1946) in the Imperial Valley.

As long as the maximum temperature of the environment stays below 40°C , the change in the cow's body temperature is only about one fortieth of the change in the environmental temperature, but when the maximum temperature of the air reaches 44°C , as in July, the cow's regulating efficiency drops to one half. Her temperature fluctuation now becomes one twentieth of that of the environment. The cow is better equipped to maintain her body temperature against a cold than against a hot environment.

Some breeds of Asiatic cattle are better adapted to hot climates than Western breeds. The Zebu cattle may thrive under conditions under which Western cattle suffer. Brody and his coworkers have investigated this difference and McDowell and his coworkers (1953) have studied the inheritance of this adaptation. They crossed Jersey cattle with Sindhi, a breed of Zebus, and exposed Jerseys and crossbreeds to an environmental temperature of 105°F (40°C) for 6 hours. Figure 8 shows some of their results. The crossbreeds maintain a body temperature close to 102°F (39°C), whereas the body temperature of the Jersey cows rises to over 103°F (39°C). The reaction of the Jerseys depends on the season. During the winter months they are least able to cope with a 6 hour exposure to 105°F (40°C), whereas during the summer months this exposure raises their body temperatures to a level not much higher than that of the crossbreeds.

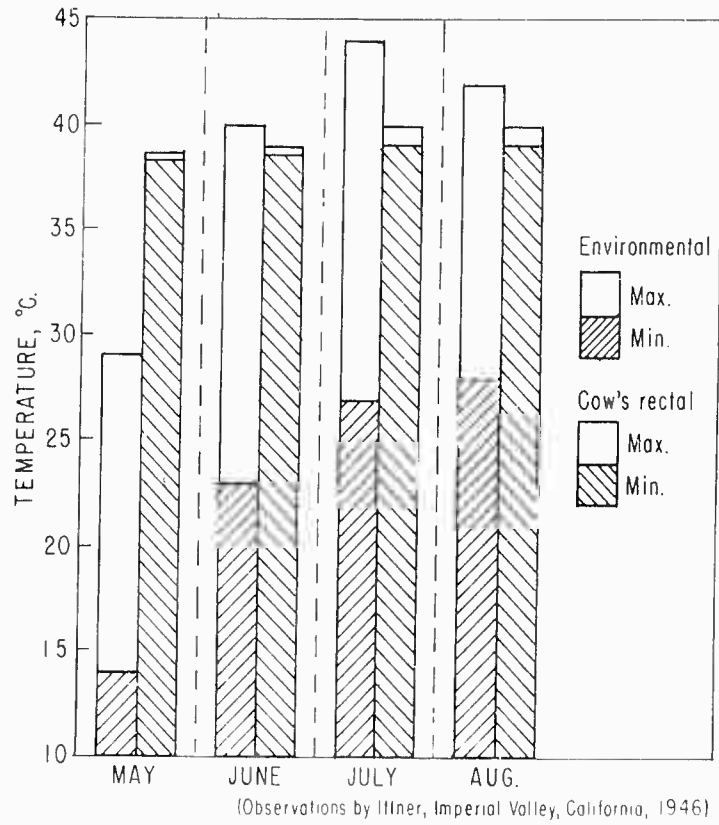

Figure 6. Daily fluctuations of a cow's body temperature compared with those of the environmental temperature.

DOMESTIC MAMMAL ADAPTATIONS

Month	Environment			Cow (rect.)	Effectiveness $\frac{\Delta \text{Envir.}}{\Delta \text{Rect.}}$
	Min. °C.	Max. °C.	Δ Envir. °C.	Δ Rect. °C.	
MAY	14	29	15	0.4	38
JUNE	23	40	17	0.4	42
JULY	27	44	17	0.9	19
AUGUST	28	42	14	0.9	16

Note: Total variation of rectal temperature 38.2 to 40 °C.
Based on observations by Ittner, Imperial Valley, Calif., 1946.

Figure 7. Daily temperature fluctuations and the effectiveness of a cow's thermostat.

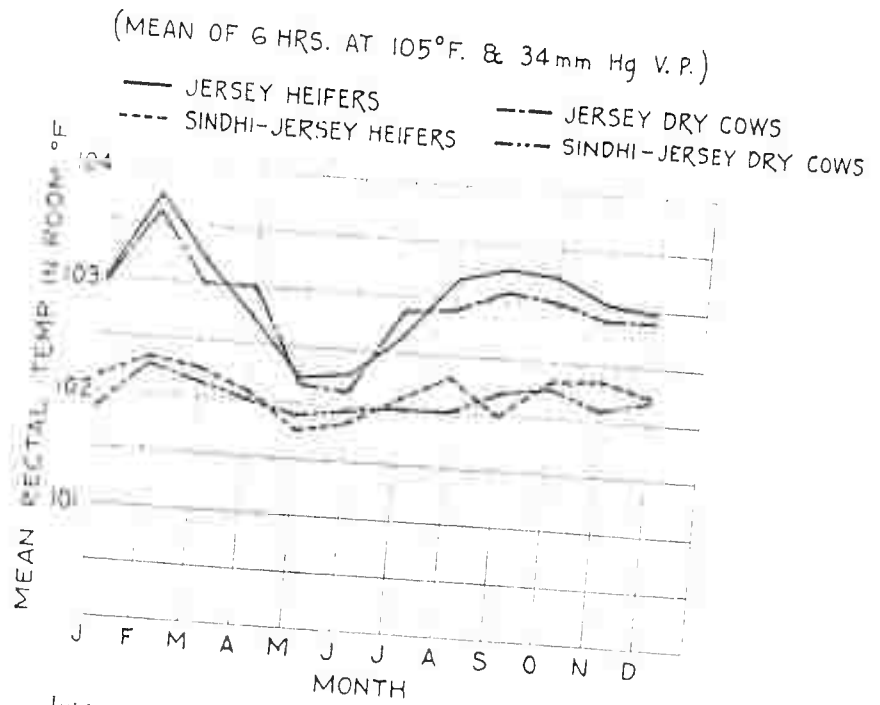

JOURNAL OF ANIMAL SCIENCE, Vol. 12, No. 4, November, 1953

Figure 8. Seasonal effects on body temperature response to heat.

DOMESTIC MAMMAL ADAPTATIONS

REGULATION AGAINST COOLING

By cooling I mean a decrease in temperature and, to the best of my knowledge, that is what Newton meant by cooling when he formulated his law of cooling which is erroneously applied when one means loss of heat rather than of temperature. Temperature regulation means prevention of cooling but not prevention of heat loss.

The classic example for adaptation to cold has been given by Hoesslin (1888). He set out to test experimentally Rubner's theory that the metabolic rate of homeotherms is proportional to their surface area because their heat loss is proportional to their surface area. Hoesslin argued if the metabolic rate is governed by the heat requirement, then it should be directly proportional to the difference between environmental temperature and body temperature. To test this deduction, Hoesslin raised one dog at 32° C and a twin brother of that dog in the refrigerator at 5° C. From his records of food consumption and his estimate of body substance produced, Hoesslin concluded that the dog raised at 5° C had a metabolic rate only 12% above that of his brother raised at 32° C. The difference between body temperature and environmental temperature of the cold dog was about six times as great as the corresponding difference for the hot dog.

Hoesslin concluded that heat requirement could not be the determining factor in the control of metabolic rate or the explanation for the surface law. He observed that the cold dog's pelt weighed 3.6 times as much as that of the hot dog, indicating an adaptation of insulation to environment. It may be that the adaptation was mainly on the side of the hot dog, that his fur was abnormally light. We now would accept Hoesslin's argument that the metabolic rate of his hot dog was not determined by heat requirement, but we would maintain that the metabolic rate of the cold dog presumably reflected a thermostatic heat requirement. This assumption is justified by the relation of metabolic rates to body temperatures of various animals

obviously reflecting the insulating power of their body covering as shown in Figure 9.

We simplify the situation by the scheme in Figure 10. If the dogs behaved strictly like ordinary thermostats, then the metabolic rate of the hot dog would be on the line between the rate of the hot dog and the rate zero reached when the environmental temperature becomes equal to the body temperature. On the scale of our figure the hot dog would produce about 16% of the "normal" rate marked 100. The hot dog, however, produces almost as much heat as his cold brother and operates special devices to get rid of the excess heat. Obviously, the metabolic rate of the hot dog cannot be explained as a heat requirement. Rubner realized that, and he explained the surface law of animal metabolism as heat requirement proportional to surface area in a cold environment and as necessary cooling power also proportional to surface area in a hot environment.

There is, however, a difference between the two dogs in their immediate reaction to cold. If the hot dog were suddenly brought to the cold living quarters of his brother, he would presumably shiver and produce more heat than the cold-adapted litter mate. If he stayed long enough in the wintery climate and if he had enough youthful adaptability he would gradually grow a fur as thick as that of his brother and quit shivering; then presumably the two dogs would have the same metabolic rates. The rise in metabolic rate is known as "chemical," or metabolic temperature regulation. By that term, Rubner simply meant an increase in the rate of chemical processes, whether or not connected with muscular movement such as shivering. The idea of chemical temperature regulation as contrasted to regulation involving shivering is a later and not too useful complication. The change in the insulation, in contrast to the change in metabolic rate, is known as "physical" temperature regulation, and, if it involves slow processes such as changing one's fur, it is classified as "acclimatization."

Scholander reports that dogs truly acclimatized to the arctic regions have a critical temperature as low as -40° C. This shows that domestication has not led to a degeneration of the dog or at least has left the dog the possibility of overcoming the softening

DOMESTIC MAMMAL ADAPTATIONS

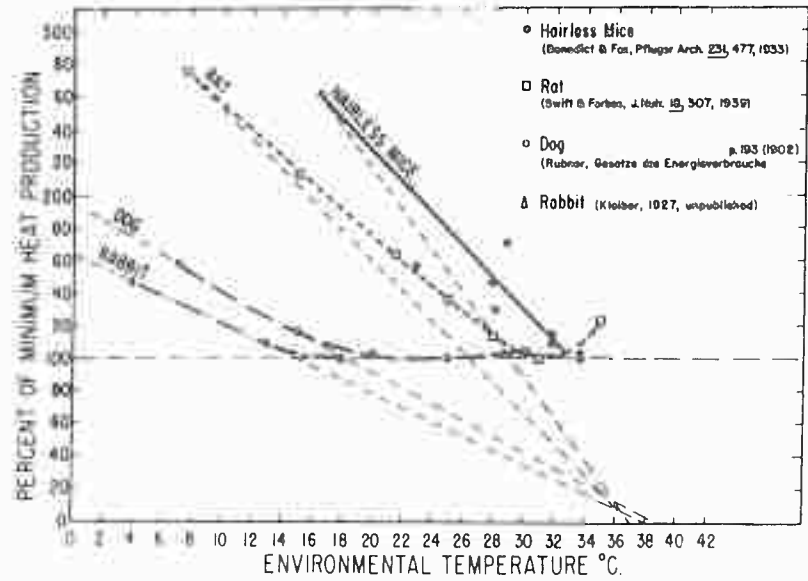

Figure 9. Fasting katabolism in the hairless mouse, the rat, the dog, and the rabbit at various environmental temperatures.

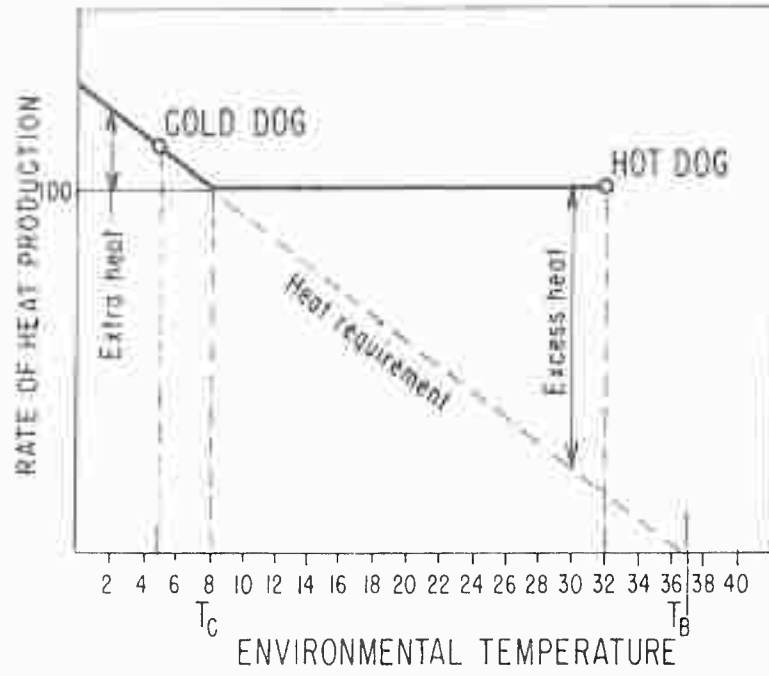

Figure 10. The rates of heat production in Hoesslin's "hot" and "cold" dogs at various environmental temperatures.

DOMESTIC MAMMAL ADAPTATIONS

effect of civilization and becoming fit to follow "the call of the wild," as Jack London would say.

Between the immediate response of shivering and the long term acclimatization of growing a thicker fur, there is an intermediary adaptation. For some time the dog brought from the hot to the cold environment would presumably respond with "insulative cooling." He would let the temperature, especially of the outer layers of his body, drop. Scholander (1958) discovered this temporary answer to cold exposure in the Australian aborigines. This adaptation is especially advantageous in climates with great diurnal temperature changes.

I remember Nansen's account of his polar expedition, especially his description of Johansen's sleeping peacefully with his bare foot stuck out from the tent into the subzero polar air. This observation indicates that the Norwegian polar explorers may also have acquired some ability to utilize insulative cooling.

Social Temperature Regulation

My account of adaptations to prevent a fall of body temperature in a cold environment would not be complete without mentioning social temperature regulation. Animals have learned to conserve heat by "togetherness," also called "huddling." That this method is effective has been shown in baby chicks, some of which were denied fulfillment of their social instinct and were forced to burn up more fuel to keep warm, while involuntarily practicing rugged individualism (Fig. 11).

REGULATION AGAINST OVERHEATING

An old method to get relief from too much heat is the use of a fan. I am told that Eskimos used this instrument not only to increase

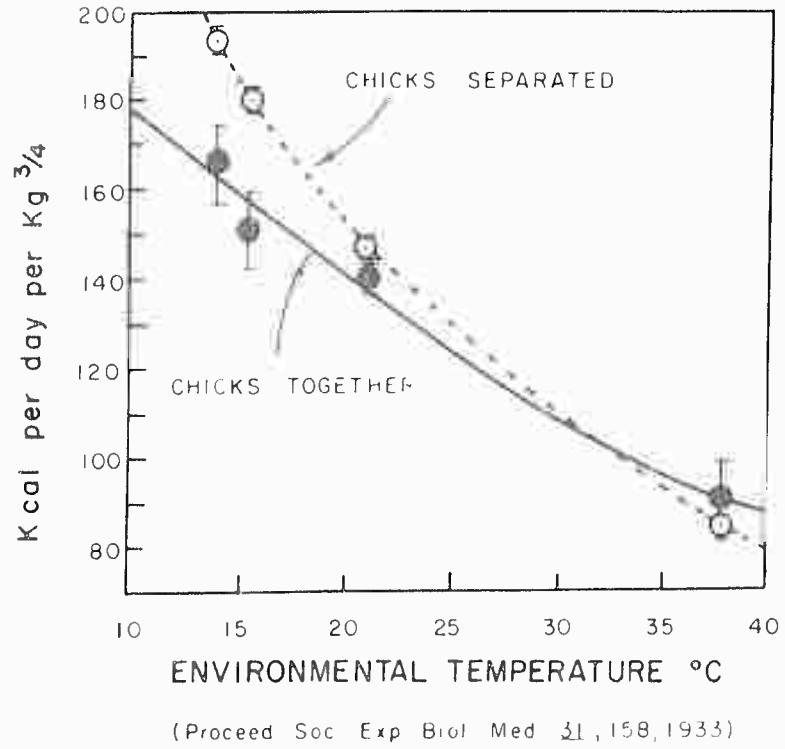

Figure 11. Social temperature regulation in chicks 20 days old.

DOMESTIC MAMMAL ADAPTATIONS

cooling but also to hide blushing and even to hide non-blushing. Steers do not worry about blushing but they get relief against overheating from fans, as shown on Figure 12, which was constructed from a table giving observations by Ittner, Bond, and Kelly (1955), in the Imperial Valley of California. The fan could keep the body temperature one degree lower than it would have been without the fan. This type of relief, of course, is given the animal by his keeper. The animal itself, however, also has methods for preventing overheating. The first reaction of an animal exposed to a high environmental temperature is to increase the blood flow to the skin, which increases the heat flux from skin to environment. This type of physical temperature regulation is effective only when the skin temperature is higher than the environmental temperature. When the air temperature and the temperature of the objects toward which an animal radiates are equal to, or higher than body temperature, more drastic means of cooling have to be taken. The last resort is water evaporation. Men and horses perspire. Dogs and cattle have discovered a flaw in this method. When the surface is wet and evaporative cooling takes place, there is not only the welcome temperature difference for the flux of heat from the interior to the surface, but also an increase in the flux from the hot environment to the animal surface. The animal therefore spends water to cool its environment. To overcome that disadvantage, cattle and dogs operate an internal evaporative cooler which leaves the surface temperature higher and keeps the heat influx lower. Dogs and cattle increase the evaporative cooling by panting. Increased respiratory ventilation, however, involves the danger of depleting the blood of CO_2 , a condition known as acapnia which causes unpleasant disturbances in the operation of the breathing reflexes. The answer to this danger is shallow breathing, increasing the ventilation rate in the upper parts of the respiratory system only, this provides the desirable increase in evaporation, with little change of the CO_2 washout from the alveoli.

Figure 13 shows the type of breathing in heat exposed cows compared with that at a low (for the cow's taste comfortable) temperature. A threefold increase in respiratory frequency produces a twofold increase in ventilation rate because the volume for each breath is reduced. Cows do not start panting at a certain

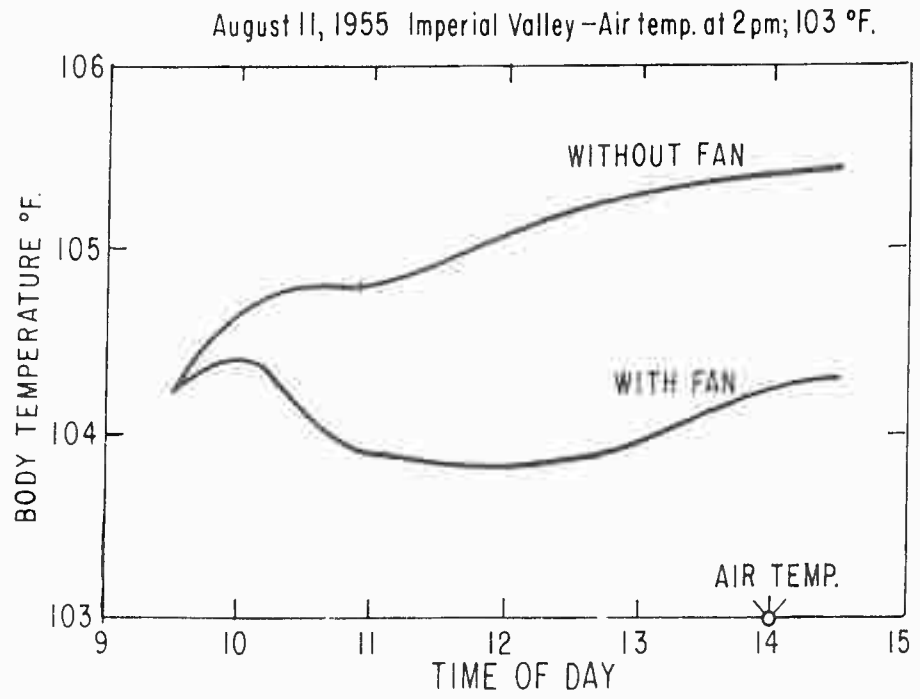

Figure 12. The effect of a fan on a steer's body temperature.

DOMESTIC MAMMAL ADAPTATIONS

	Environmental 7°C.	Temperature 32°C.
Breaths per minute	15.5 ± 0.3	46.0 ± 3.8
Respired air per minute, liters	52 ± 3	105 ± 5
Respired air per breath, liters	3.4 ± 0.2	2.2 ± 0.04

(Proceed. Soc. Exp. Biol. Med. 33, 10-14, 1935).

Figure 13. Physical temperature regulation in cows. The adaptation of breathing at various environmental temperatures.

environmental temperature. As they get warmer, their breath rate increases rather gradually, so that the relation between respiratory frequency and the environmental temperature can well be expressed by the Arrhenius equation.

Figure 14 shows the logarithm of respiratory frequency plotted against the reciprocal of the environmental temperature in degrees Kelvin.

The idea that cows do not perspire at all through their body surface has been proven erroneous. Figure 15 summarizes the results of Kibler and Brody (1952), which indicate that indeed a great part of the heat given off by cows, especially in a hot environment, is accounted for by surface evaporation, and the evaporation in the respiratory system amounts to only one-third of the total evaporation.

Kibler and Yeck (1959) later observed that the greater heat tolerance of Brahman cattle compared with shorthorns is related to a greater evaporative capacity and that in particular the ratio of skin evaporation to respiratory evaporation is greater in the heat tolerant Brahmans. The major advantage of the Brahmans, however, in combating overheating, according to Kibler and Brody (1954), is their relatively low metabolic rate, about 80 kcal/(m² x hr) as compared with 150 kcal/(m² x hr) in Jerseys and Holsteins.

The Method of the Camel

The most ingenious system of keeping cool has been developed by the camel, also known as the ship of the desert. The U. S. Navy has a perfectly good reason, therefore, for supporting research on this animal by Knut and Bodil Schmidt-Nielsen, a team of extraordinarily keen observers.

The camel apparently realizes the advantage of inside cooling as opposed to surface cooling. It also is very much interested in the most economic use of water and can hardly afford to have sweat drop to the ground unevaporated, as it does in human athletes and in

DOMESTIC MAMMAL ADAPTATIONS

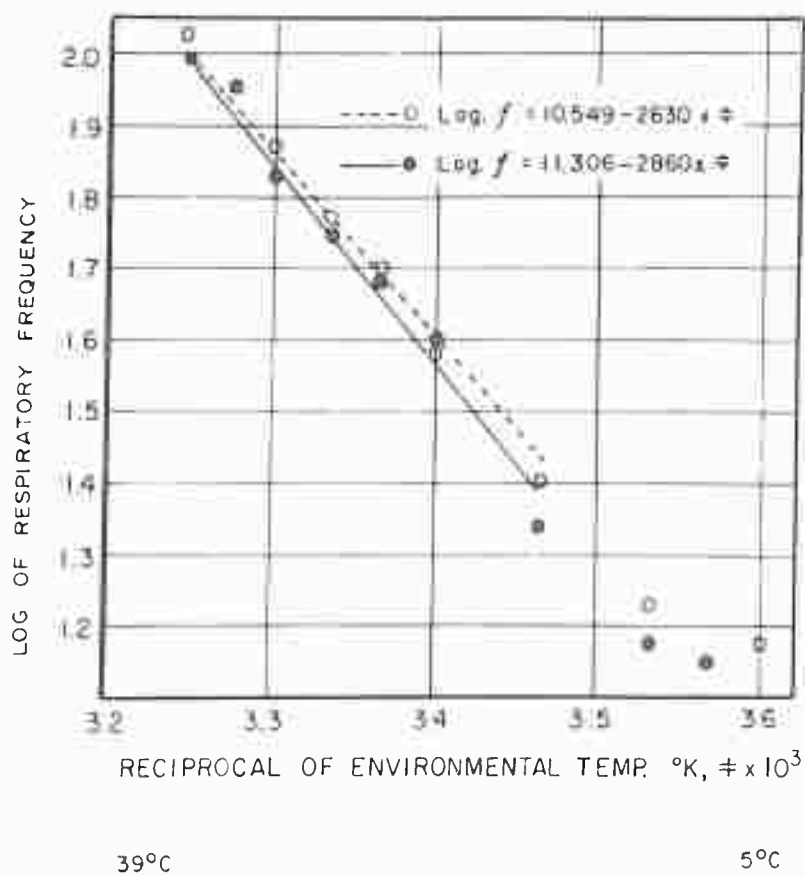

Proc. Soc. Exp. Biol. Med. 33: 11 (1935)

Figure 14. The Arrhenius equation for cow's respiratory frequency.

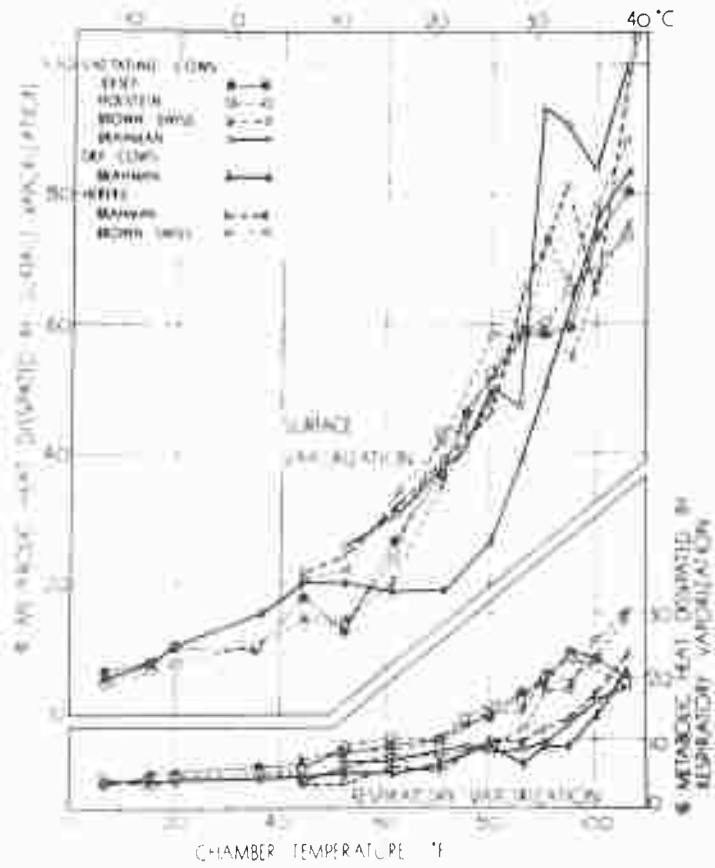

Kibler & Brody

Mo. Research Bulletin 497 (1952)

Figure 15. Percentage of metabolic heat dissipated by surface vaporization.

DOMESTIC MAMMAL ADAPTATIONS

horses. Yet the camel apparently does not think much of panting and, having observed panting cows and dogs, I cannot blame the camel for disliking that method. The ship of the desert solves the problem by making the skin surface an inside surface insulated by an effective fur. This leaves the outer surface of the hair hot and dry, minimizing the heat influx from the environment and reserves the entire cooling effect of the evaporation for the benefit of the animal.

The Schmidt-Nielsens and their coworkers (1957) demonstrated the importance of the fur in water economy by clipping a camel's hair. The result is shown in Figure 16 which is redrawn from Figure 1 in Schmidt-Nielsen's paper. Under given conditions, the furry camel uses 2 liters of water per day per 100 kg body weight. Clipping of the hair increases the water loss to 3.7 liters daily per 100 kg body weight.*

Schmidt-Nielsen et al. also measured the water expenditure of a donkey (presumably under the same conditions as the camel), and they state that the donkey wastes more water even than the clipped camel. As a good Democrat I am bothered by this wastefulness of the donkey and I think the accusation is unjustified. For a fair comparison of wastefulness, the rates of evaporation should be expressed per unit surface area instead of body weight, and when rates are expressed that way, the donkey is just as economical in the use of water as the clipped camel. To demonstrate the fallacy of the comparison per unit body weight for this discussion, I have added the probable rate of water loss of a 4000 kg elephant, and the result shows that by Schmidt-Nielsen's comparison the elephant is much more economical with water than even the furry camel. I must warn my Republican colleagues not to get too excited about this result. It is just a matter of body size, and the fact that elephants are bulkier than donkeys has no political significance. I hasten to mention that in fact my calculation is based on the strictly bipartisan assumption that the evaporation rate per unit surface area is the same for donkey and elephant.

Figure 17 shows the calculations which show the same water loss for the camel and the donkey per unit surface area.

*Some water may be used for the excretion of metabolic products in urine, but under the circumstances, evaporation presumably accounts for most of the water used.

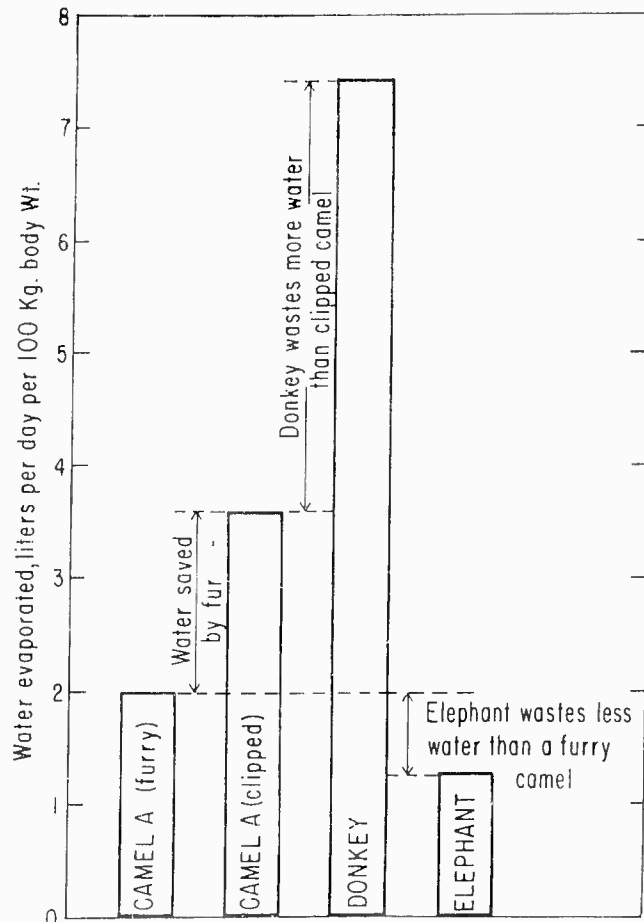

Data on camel and donkey from Schmidt-Nielsen et al Amer J. Physiol. 188 p. 110, 1957. Elephant calculated with equal evaporation rate per m² surface area as donkey

Figure 16. The effect of clipping and of body size on rate of water evaporation per unit body weight in camel, donkey, and elephant.

DOMESTIC MAMMAL ADAPTATIONS

	Camel	Donkey
Body weight	206 Kg	81 Kg
Surface area $W^{2/3}$	34.9 Kg ^{2/3}	18.7 Kg ^{2/3}
Daily water used per 100 Kg (Schmidt-Nielsen 1957*)	3.5 lit.	7.3 lit.
° " " " animal	7.2 "	5.9 "
" " " " Kg ^{2/3}	0.206 "	0.206 "
" " " " Kg ^{3/4}	0.133 "	0.218 "

*Amer. J. Physiol. 188, pg 110 Fig.7, 1957

Figure 17. Rate of water evaporation in the camel and the donkey.

The water loss per interspecific unit of body size is $\text{kg}^{3/4}$ (Kleiber, 1947). This interspecific unit is a unit of probable metabolic rate and it shows that the donkey had a higher rate of water loss than the clipped camel.

The comparison of rate of water loss between donkey and camel leads not to one but to several different conclusions, and no one is absolutely superior to the others. Assuming isometric composition of the two animals, the conclusion based on loss per unit body weight indicates that the donkey loses a given percentage of its body water twice as fast as the camel. For an estimate of the daily water requirement of a caravan, it may be of interest to know the water loss per animal--7.2 liters per camel, 5.9 liters per donkey. For a comparison of mechanisms of heat transfer it is noteworthy to know that both camel and donkey lose daily 2.1 liters H_2O per m^2 of surface area. For comparisons of the rates of water loss with metabolic rates, the loss per interspecific unit of metabolic body size is the most useful.

Daily Heat Load and Body Size

In many regions, especially deserts, it is very hot during a period of the day and cold during the night. Under those circumstances the larger animal has an advantage over the smaller one because heat load is proportional to body surface and heat capacity proportional to body weight. The rise in body temperature for a given period of excessive temperature during the day is therefore inversely proportional to the cube root of body weight. Figure 18 illustrates this relation.

It is assumed that during a 6 hour period every day the influx of heat exceeds the animal rate of heat loss so that during this 6 hour hot period 2.5 kcal of heat are stored in the animal per dm^2 of its body surface. This would be a rate of influx of 250 kcal per m^2 in 6 hours and would equal the basal metabolic rate which, according to Rubner, is 1000 kcal per day per m^2 .* What is the rise in body temperature at the end of the 6 hour period resulting from this storage?

*This is approximately correct for an animal of 100 kg body weight, whereas smaller animals produce less, larger ones more heat per m^2 per day.

DOMESTIC MAMMAL ADAPTATIONS

Body Weight	Surface Heat cap.	Change in Body Temp.
W	$= 12.5 \times W^{-\frac{1}{3}}$	$= 2.5 \frac{\text{Surface}}{\text{Heat cap.}}$
Kg.	$\frac{\text{dm}^2}{\text{kcal} / ^\circ\text{C.}}$	$^\circ\text{C.}$
1	12.5	31.4
10	5.81	14.5
100	2.70	6.7
1000	1.25	3.1
10000	0.58	1.4

Figure 18. Periodic heat load, body size, and body temperature for a periodic heat storage of 2.5 kcal per dm^2 . For a 6-hour period the rate of this storage would be equal to the daily metabolic rate of one megacal per m^2 (Rubner).

KLEIBER

The surface area in square decimeters may be estimated to be $10 \times W^{2/3}$, where W is the body weight in kg. The heat capacity of the animal may be estimated as kg water $\times 0.4 \times$ kg dry matter in the animal (Kleiber, 1961). Assuming a water content of 68%, the heat capacity of the animal would therefore amount to $0.81 \text{ kcal/}^\circ\text{C}$ per kg body weight. The ratio of surface area to heat capacity then would amount to

$$\frac{10 \times W^{2/3}}{0.81W} \text{ or } 12.5 W^{-1/3} \quad (\text{second column in Figure 18})$$

The increase in body temperature from the storage of 2.5 kcal/dm^2 then amounts to $2.5 \times 12.5 W^{-1/3}$. This rise would be 31.4°C for an animal weighting 1 kg and 1.4°C for a 10 ton super elephant. A large animal, therefore, may comfortably survive discontinuous daily heat loads which are fatal for smaller animals. When, however, the heat load is continued, the advantage of size is lost.

Professor Regan at Davis noted that a cow can stand a good deal of heat during the day when she cools off during the night, whereas a constant rather moderately high temperature in an air conditioned room may be fatal.

The camel can take advantage of cool nights by letting its body temperature decrease to 34°C (see Schmidt-Nielsen). A human being could hardly stand this, nor could he let his body temperature rise to 41°C when water is short and the day hot.

Schmidt-Nielsen feels that this relatively large change in body temperature should not be regarded as a failure regulation, but rather as an adaptation which conserves water. It may be more cautious to say that in this case the water economy at the cost of an accurate temperature regulation proves advantageous for survival.

The difference between controlled and run away increase in body temperature, the latter resulting from positive feedback, is clearly shown in a plot of pigs' body temperature against time of exposure to various environmental temperatures, observed by Robinson and Lee (1942).

DOMESTIC MAMMAL ADAPTATIONS

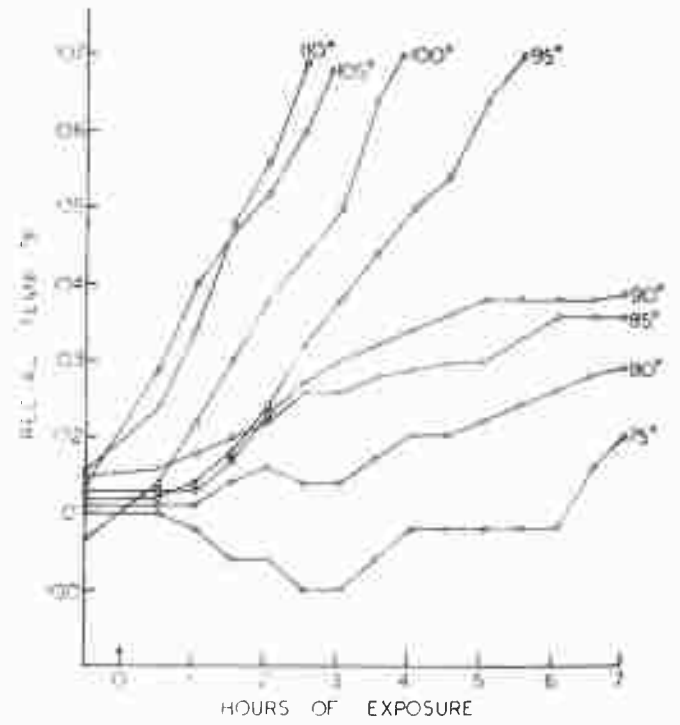

ROOM TEMP IS SHOWN WITHIN THE GRAPH

FROM: K. ROBINSON AND D. H. K. LEE
PROC. ROY. SOC. QUEENSLAND 53 (9) 145 (1942)

Figure 19. A pig's body temperature in 75° F to 110° F air.

TEMPERATURE AND FOOD UTILIZATION

An animal that is producing flesh or other forms of animal product invariably has a higher metabolic rate than a non-producing and especially a fasting animal would have. The difference in heat production between the fed and the fasting animal is called the "heat increment", or the calorogenic effect of food, or the specific dynamic effect of food, an intriguing name considering the fact that the effect is neither specific nor dynamic.

This calorogenic effect of food intake means a relief to the animal in its fight against a cold environment and an extra burden in the regulation against overheating.

The situation is illustrated in Figure 20. At a low environmental temperature the metabolic rate, being determined by the heat requirement, will be the same for fed and fasting animals. There is thus no calorogenic effect of the food. At this low environmental temperature the extra heat for thermostatic control is now less because the minimum heat production of the fed animal is higher than that of the fasting animal, and the calorogenic effect of the food helps to heat the animal. The critical temperature of the fed animal (T_{cf}) for that reason is lower than that of the fasting animal (T_{co}). Between these two temperatures the calorogenic effect of the food increases from zero to C_m in proportion to the increase in environmental temperature. Rubner called the description of this effect his compensation theory. The calorogenic effect compensates for the thermostatic rise in heat production of the fasting animal.

Above the critical temperature of the fasting animal, the calorogenic effect of the food is independent of changes in environmental temperature. The excess heat of the fed animal is greater than that of the fasting animal. This means an extra burden in the fight against overheating. If this burden becomes significant, it affects the food intake. At a sufficiently high environmental

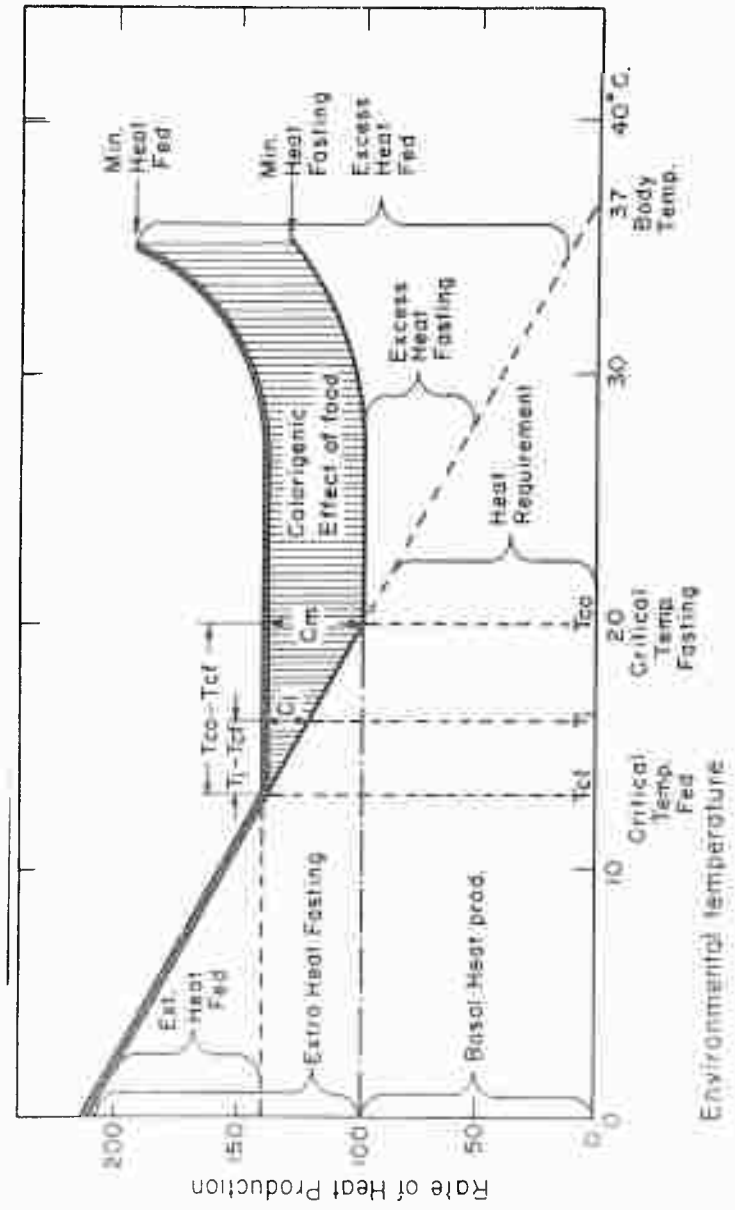

Figure 20. Metabolic rates of a fed animal at various environmental temperatures.

KLEIBER

temperature, the animal may eat only enough for maintenance, as illustrated in Figure 21 (Kleiber and Dougherty, 1934).

This temperature (T_{max}) is the highest environmental temperature for animal production. As the environmental temperature is decreased, the animal will eat more, and the net energy, appearing in the animal product, N , will rise. Below the critical temperature of the full fed animal, T_{c_3} , the heat production will be determined by the thermostatic heat requirement. Since the capacity for food intake is limited, whereas the heat requirement continues to increase with decreasing environmental temperature, less and less energy is available for production, and at the temperature, T_{min} , the maximum food intake of the animal provides just enough heat for maintaining the animal's body temperature. Below this temperature the animal will eat all it can and yet starve to death because it will have to burn up its own body substance in addition to all the food it can eat in order to maintain its body temperature. This situation may be less significant for practical purposes than the lack of food in a cold environment which calls for human action such as operation "Hay Lift". Between the low temperature, at which the animal eats a lot but needs most of the food for fuel for keeping warm, and a high temperature at which it loses appetite to such an extent that it burns up all it takes in for maintenance, there should be an optimal environmental temperature at which the efficiency of animal production is at a maximum. This is illustrated on the lower part of Figure 21.

An indication, though not too obvious, of such a temperature optimum has been obtained in respiration trials with lactating cows fed to capacity with alfalfa hay, beet pulp, and grain, and kept alternately for weekly periods at $7^{\circ}C$, $18^{\circ}C$, and $30^{\circ}C$ (Kleiber, 1961). Total carbon and nitrogen balance was determined over a three day period during each week.

The results are shown in Figure 22. The decline in food intake at a high environmental temperature is most conspicuous. The milk production was little affected, but the loss of body substance was greater at the low and at the high temperature, than at $18^{\circ}C$ where the net energy was at a maximum.

DOMESTIC MAMMAL ADAPTATIONS

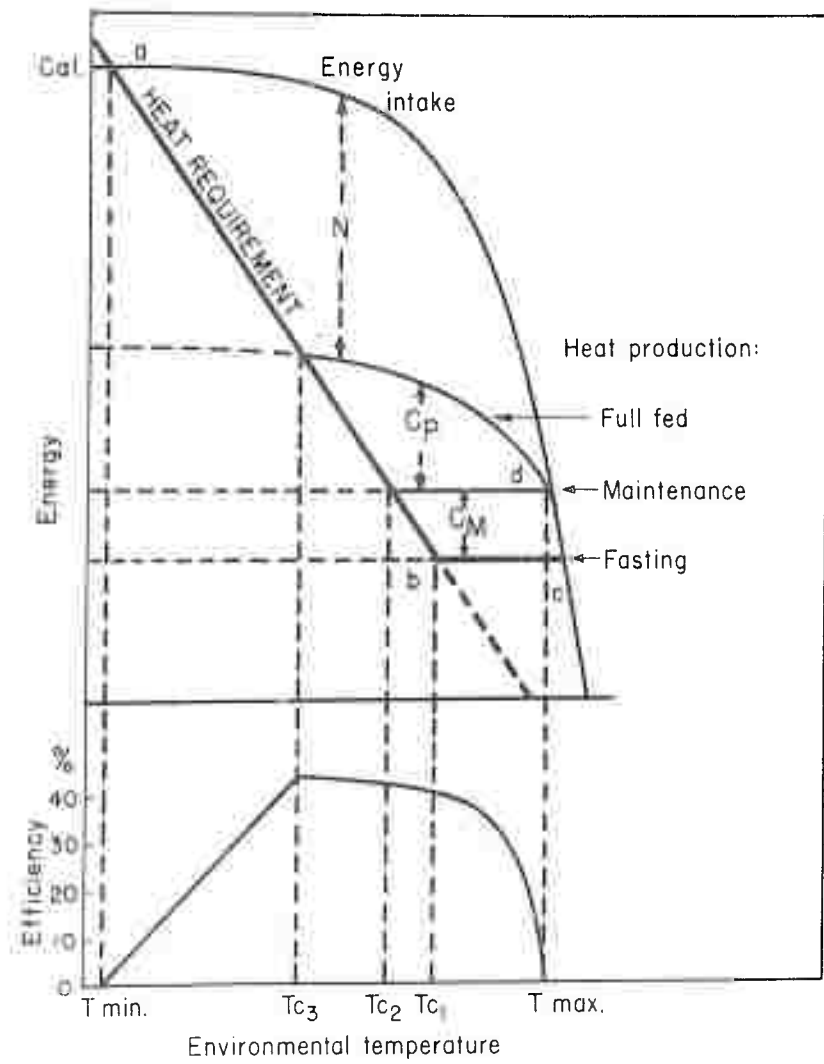

J. Gen. Physiol. 12: 703 (1934)

Figure 21. Scheme of influence of environmental temperature on food utilization.

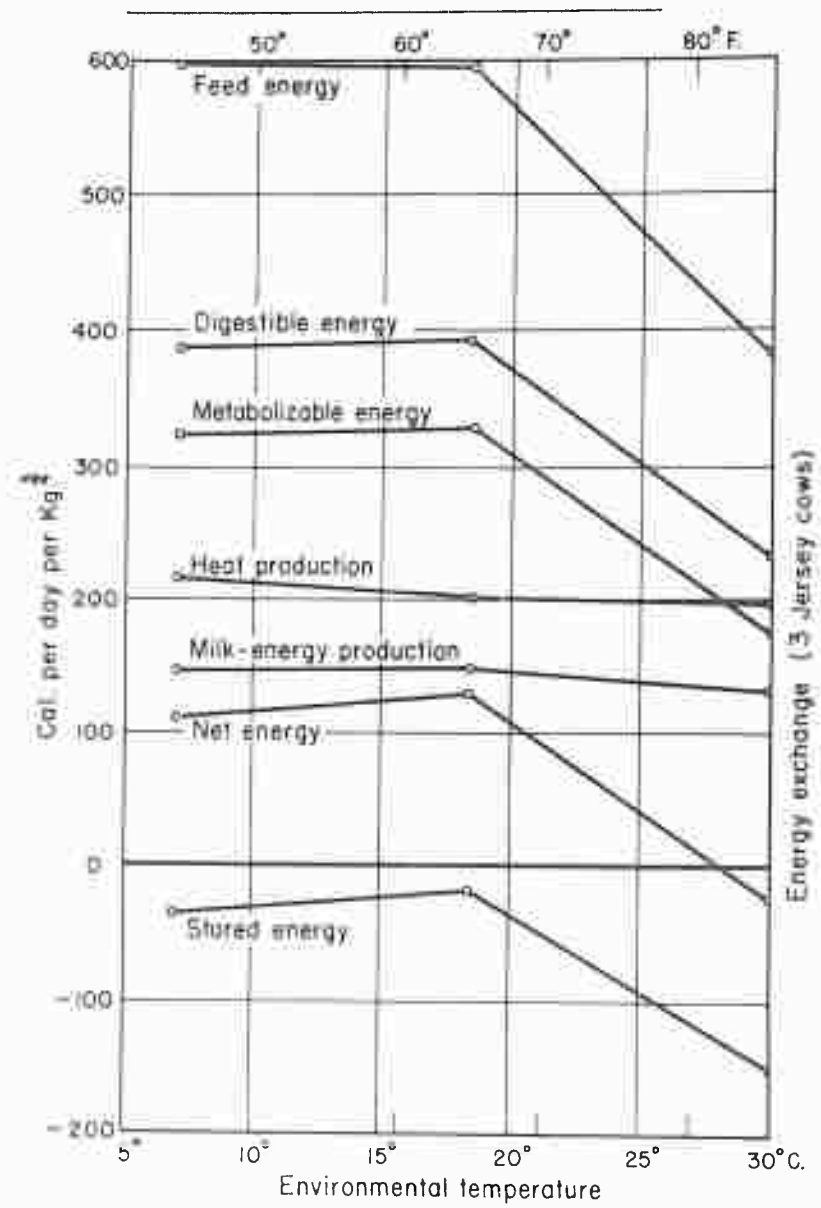

Figure 22. Food utilization of dairy cows at various environmental temperatures.

DOMESTIC MAMMAL ADAPTATIONS

Figure 23 shows a hydraulic model as an analog of animal energy utilization in which the effect of cooling power is coordinated with other effects such as stimulus for milk production and for growth on the regulation of food intake. This was an early suggestion (Kleiber, 1936) of the two great regulators of food intake, a chemostatic principle now worked out especially convincingly by J. Mayer (1953) and the thermostatic principle represented especially by Strominger and Brobeck (1953).

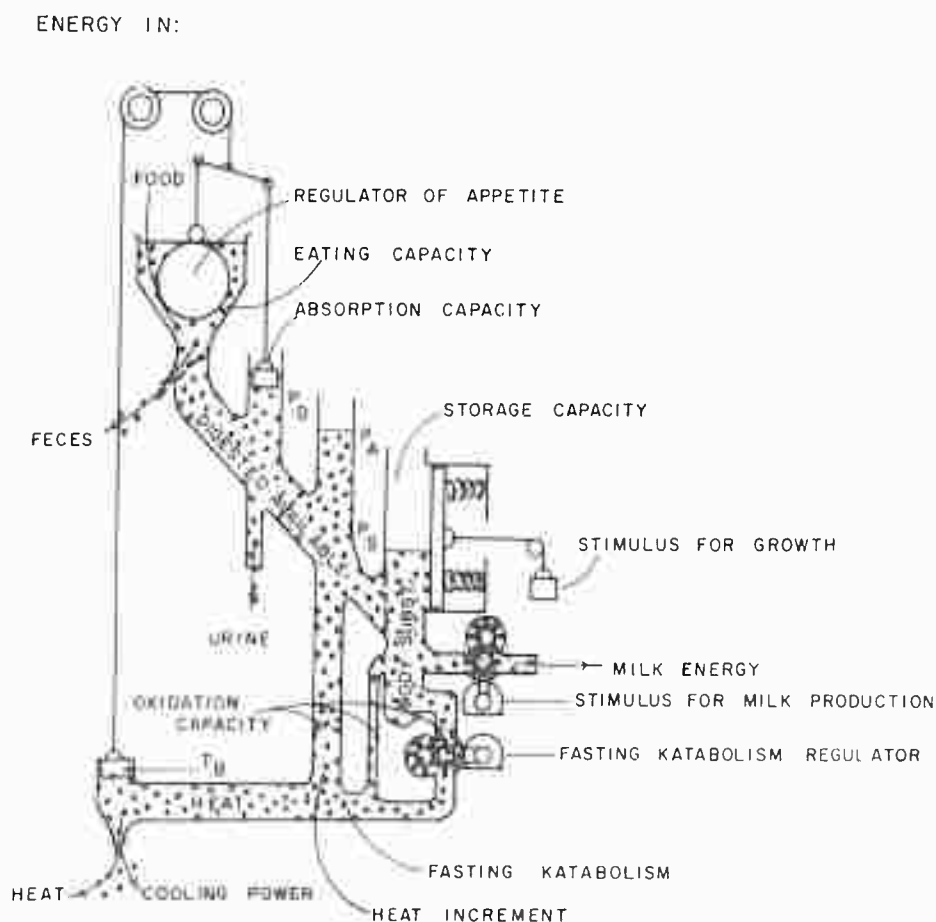

Figure 23. Scheme of energy-utilization.

KLEIBER

SUMMARY

Domestication has not essentially changed the basic responses of animals to challenges from cold or hot environments.

A reaction to cold exposure, common to man and other homeotherms, is an increase in metabolic rate called chemical temperature regulation. A more economical response, known as insulative cooling, has been lost by civilized man, but operates in domestic animals and Australian aborigines.

In order to adapt to continued cold exposure, animals increase their insulation mainly by growing a thicker fur. Man has replaced this adaptation by technical control of the microclimate.

Overheating is prevented mainly by evaporative cooling at the body surface or in the respiratory system. Contrary to older belief, cattle evaporate more water from the skin than by respiration, even though respiratory frequency increases consistently with increase in environmental temperature.

Evaporation from a wet body surface in a hot environment is uneconomical because it allows an influx of heat from the environment to the surface.

The camel's fur maintains its outer surface dry and hot, minimizing the influx of heat to the skin which is kept cool by evaporation. Clipping of the fur increases the camel's water loss in a hot environment to a rate per unit area similar to that of a donkey.

Excessive but time-limited daily heat loads producing heat storage in the body can be endured better the larger the animal because heat load is proportional to body surface area and heat capacity is proportional to body weight. Increase in body temperature for given loads, therefore, is proportional to the reciprocal of the cube root of body weight.

DOMESTIC MAMMAL ADAPTATIONS

Animal production increases metabolic rate and consequently the problem of overheating. The breeds of cattle which are best adapted to endure hot climates are usually low producers with relatively low rates of heat production.

LITERATURE CITED

1. Hoesslin, H. V. 1888. Ueber die ursache der scheinbscheinbaren Abhängigkeit des Umsatzes von der Grösse der Körperoberfläche. Arch. Physiol. 11:323-379.
2. Ittner, N. R. 1946. A progress report on livestock investigations in the Imperial Valley. College of Agr., Univ. of Calif., Davis. Table 1, p. 3.
3. Ittner, N. R., T. E. Bond, and C. F. Kelly. 1955. Methods of increasing beef production in hot climates. Cal. Exp. Sta. Bul. 761, Table 13.
4. Johnson, H. D., C. S. Cheng, and A. C. Ragsdale. 1958. Comparison of the effect of environmental temperature on rabbits and cattle. Missouri Res. Bul. 648:1-27.
5. Kibler, H. H. and S. Brody. 1952. Relative efficiency of surface evaporative, respiratory evaporative, and non-evaporative cooling in relation to heat production in Jersey, Holstein, Brown Swiss and Brahman cattle, 5° to 105° F. Missouri Res. Bul. 497:19.
6. Kibler, H. H. 1954. Influence of radiation intensity on evaporative cooling, heat production and cardiorespiratory activities in Jersey, Holstein and Brahman cows. Missouri Res. Bul. 574:20.
7. Kibler, H. H. and S. Brody. 1956. Influence of diurnal temperature cycles on heat production and cardio-respiratory activities in Holstein and Jersey cows. Missouri Res. Bul. 601:10.
8. Kibler, H. H. and R. G. Yeck. 1959. Vaporization rates and heat tolerance in growing Shorthorn, Brahman, and Santa Gertrudis calves raised at constant 50° and 80° F temperatures. Missouri Res. Bul. 701.

DOMESTIC MAMMAL ADAPTATIONS

9. Kleiber, M. 1947. Body size and metabolic rate. *Physiol. Rev.* 27:538.
10. Kleiber, M. 1936. Problems involved in breeding for efficiency of food utilization. *Am. Soc. Animal Prod. Proc.* p. 247-258.
11. Kleiber, M. 1961. *The Fire of Life, and introduction to animal energetics.* Wiley and Sons, New York, p. 102.
12. Kleiber, M. and J. E. Dougherty. 1934. The influence of environmental temperature on the utilization of food energy in baby chicks. *J. Gen. Physiol.* 17:701-726.
13. Kleitman, N. 1951. When your temperature goes up. *San Francisco Chronicle "This Week"*, March, p. 18-19.
14. Kleitman, N., S. Titelbaum and P. Feievson. 1935. Diurnal variation in reaction time and its relation to body temperature. *Am. J. Physiol.* 113:82.
15. Lee, R. C. 1939. The rectal temperature of the normal rabbit. *Am. J. Physiol.* 125:521-529.
16. McDowell, R. E., C. A. Matthews, D. H. K. Lee and M. H. Fohrman. 1953. Repeatability of an experimental heat tolerance test and the influence of season. *J. Animal Sci.* 12:757-776.
17. Mayer, J. 1953. Genetic, traumatic and environmental factors in the etiology of obesity. *Physiol. Rev.* 33:472-508.
18. Richet, Ch. 1889. *La Chaleur Animale.* Felix Alcan, Paris, p.23.
19. Robinson, K. W. and D. H. K. Lee. 1942. Reaction of the Pig to Hot Atmospheres. *Proc. Roy. Soc. Queensland* 53:145-158.

KLEIBER

20. Schmidt-Nielsen, K., B. Schmidt-Nielsen, S. A. Jarnum and T. R. Houpt. 1957. Body temperature of the camel and its relation to water economy. *Am. J. Physiol.* 188:103-122.
21. Scholander, P. F. 1955. Evolution of climatic adaptation in homeotherms. *Evolution* 9:15-20.
22. Scholander, P. F. 1958. Studies on man exposed to cold. *Fed. Proc.* 17:1054-1057.
23. Strominger, J. L. and J. R. Brobeck. 1953. A mechanism of regulation of food intake. *Yale J. Biol. Med.* 25:383.

DOMESTIC MAMMAL ADAPTATIONS

DISCUSSION

EAGAN: There are three minor points I should like to make. First, Figure 1 showed that the rectal temperature of the rabbit decreased in response to a moderate decrease in environmental temperature. I know that this has been shown by some people, for instance by Carlson (1955),* but we have not seen this--not even in rabbits that were exposed to -25°C . There is no change in rectal temperature in mature animals exposed at -25°C for several hours (Eagan, 1961).**

Secondly, Burton presented a theory on why the body temperature is regulated at about 37°C . This theory is presented in the first chapter of *Man in a Cold Environment* (Burton and Edholm, 1955)*** to support the suggestion that the level of body temperature adopted by the homeotherms has something to do with the stability of temperature regulation. It is a matter of choosing a temperature which favors economy in physiological function over the widest range of environments.

KLEIBER: What is that theory?

EAGAN: I would refer the listeners to the original work cited above. Briefly, the regulated body temperature is that one from which a deviation will cause the change in heat production (Arrhenius' law) to be balanced by the change in heat loss (Newton's law of cooling), at the 25°C annual isotherm where homeothermic animals are believed to have originated.

*Carlson, L. D. 1955. Interrelationship of circulatory and metabolic factors. pp 13-51 in Ferrer, M. Irene, Ed., *Cold injury* (Trans. Third Conf.). Josiah Macy, Jr. Foundation, New York.

**Eagan, C. J. 1961. Reactive error in the measurement of rectal temperature in the cold. AAL TN 59-20, USAF Arctic Aeromed. Lab., APO 731, Seattle, Wash.

***Burton, A. C. and O. G. Edholm. 1955. *Man in a cold environment*. Edward Arnold (Publishers) Ltd., London.

KLEIBER

The third point is that heat loss in the rabbit exposed to high temperatures is certainly accomplished through panting. I did some experiments wherein rabbits were exposed at 50° C (Eagan, 1961).* In spite of vigorous panting by each animal, rectal temperature rose steadily (after a transient slight decrease) and ear temperature ran between 1° C and 2° C higher than rectal temperature.

FOLK: Is there a histological difference in the skin of the Brahman cattle and the American domestic breeds? Are there sweat glands in any of the cattle?

KLEIBER: Apparently the histologists agree that there are sweat glands in both breeds.

WEST: I was interested in the caloric intake of the cows; you have quite a nice curve of caloric intake as temperature falls. Is this something that they just do without any forcing or do they just eat this much so they can produce milk or something?

KLEIBER: This was a theoretical, not an empirical curve. I was attempting to figure out what we have to look for.

WEST: I see, because I was wondering how you were able to get cows to do this. We are trying to do this with birds.

KLEIBER: It was just an arbitrary expression, that there must be some limit where the temperature is too high for food intake, and there must be some low temperature limit where the food intake must be increased. I drew a curve against these two limits.

WEST: In other words, you think of it as a curve, not as a straight line more or less paralleling the resting metabolism or heat requirement?

KLEIBER: Well, it could be a straight line, perhaps, but I do not see how.

*Eagan, C. J. 1961. Tropical adaptation to cold in the rabbit ear. *Fed. Proc.* 20, No. 1. Part 1:210.

DOMESTIC MAMMAL ADAPTATIONS

WEST: It seems as though it were the same as maximal activity.

KLEIBER: The only reason I am not particularly happy with the straight line is that usually these things do not stop all at once.

WEST: I was thinking of the work that Dr. Jansky showed, where all the maximal rates were nearly parallel; this would be a similar situation.

KLEIBER: It may be that within a certain range it might be parallel with the other curve for resting metabolism, and then smooth out.

JOHANSEN: I found it very peculiar that you could apply "Arrhenius" so beautifully on the breathing rate of your cows. This is very much different from what I found in the armadillo. They increase their breathing rate suddenly; some marsupials do, too.

PROSSER: I would also question that Arrhenius plot, because you are plotting the breathing rate against external temperature. What does this mean? One would think if you are going to extrapolate to a chemically determined rhythm, you should do this against body temperature instead of environmental temperature.

KLEIBER: Well, the body temperature remains essentially constant; that is, within a small range.

PROSSER: In that case I am wondering what is the meaning of the Arrhenius coefficient.

KLEIBER: Here you embarrass me, because the meaning is completely unknown to me. It just happens to be so and the only thing which I can deduce is that the breathing rate of the cow is not the same function of environmental temperature as that of the armadillo.

HANNON: This brings up a question that we have wondered about for a long time. That is, why do small animals lose weight when you first put them in the cold? Is it due to a lack of appetite,

KLEIBER

to a lack of capacity in their G. I. tract for the extra food that is needed, or is it due to some other factor? I would like to hear Dr. Hart's opinion on this eventually, but from the data that Dr. Vaughan and I have accumulated with diets of a high caloric density, it would seem that the capacity of the G. I. tract is not the limiting factor. You can give them plenty of calories but they will still not eat enough to gain weight at the same rate as their controls. Eventually, however, they will be able to increase their food consumption, so that they can gain weight. It has been my feeling that the reason it takes a while for the cold-exposed animal to acquire the capacity to utilize more food and thus to gain weight is that he is not initially able to metabolize food material at a fast enough rate to supply all of his energy needs. Until he builds up an enzyme capacity to do this, his growth is going to lag behind the control animal.

HART: I would be very surprised if you could, by overfeeding an animal, increase its capacity to oxidize the material. In other words, the appetite would be regulated by internal mechanisms adjusted to the oxidative capacity of the animal, and by pushing food in you are not going to change this.

HANNON: In our studies we compared the food consumption and growth of rats that were maintained on a high carbohydrate diet with rats that were maintained on a high fat diet. It was found that the group subsisting on carbohydrate consumed much greater bulk of food but the same number of calories as the group subsisting on fat.

Apparently their ability to utilize the calories was the limiting factor, not the ability to get calories into the digestive system.

HART: Did the carbohydrate or the fat diet have any particular advantage?

HANNON: Not as far as we could see.

KLEIBER: Yes, I think the limiting capacity is not the capacity of the volume. Adolph showed this when he diluted diets with clay and other kinds of inert matter. His rats took in and digested as

DOMESTIC MAMMAL ADAPTATIONS

much energy with the bulky diet as with the other. This is in line with Jean Mayer's* idea of the regulation of the food intake, which is a hemostatic principle. It may have been slightly premature to suggest in my scheme of 1926** that these two regulators of food intake, namely the hemostatic principle (which is affected by concentrations of material in the blood stream) and the thermostatic principle, proposed by Brobeck according to which food intake is affected by the possibility of getting rid of heat.***

EAGAN: Limitation in oxidative capacity is not the only factor, for in rabbits which are moved to a cold (5° C) environment, food intake will often be less than normal for the first week or so, whereas a 50% to 100% increase would be required if body weight were to be maintained. It can hardly be thought that oxidative capacity is reduced when the animal is moved into the cold. An explanation must be sought for its change in behavior--a failure to eat sufficiently even though food is continuously available. This must represent an effect of cold stress upon the organism as a whole.

HANNON: I think this is possible in some animals, anyway. I do not think it appears in rats.

VAUGHAN: Rats will increase their food intake within a couple of days after you put them in the cold--the delay is probably partially due to the shock of putting them into the cold environment, but it is also probably due to just moving them into different surroundings. If they are accustomed to a certain diet, we have found, especially with synthetic diets, that they will increase their food intake very rapidly in the cold within a few days, e. g., up to 50% over their normal rate of intake.

*Mayer, J. 1953. Genetic traumatic and environmental factors in the etiology of obesity. *Physiol. Rev.* 33:472-508.

**Kleiber, M. 1926. Problems involved in breeding for efficiency of food utilization. *Amer. Soc. Animal Prod. Proceed.* pp 249.

***Kleiber, M. 1961. *The Fire of Life. An Introduction to Animal Energetics.* New York, Wiley and Sons, Inc. pp 282 ff.

***Brobeck, J. R. 1946. Regulation of Energy Exchange. *Howell's Textbook of Physiology.* (J. F. Fulton, ed.) Philadelphia, Saunders.

COMPARATIVE PHYSIOLOGY
OF TEMPERATURE REGULATION

PART 3

Editors

JOHN P. HANNON
ELEANOR VIERECK

ARCTIC AEROMEDICAL LABORATORY
FORT WAINWRIGHT
ALASKA
1962

RESPONSES AND ADAPTATIONS OF WILD BIRDS TO ENVIRONMENTAL TEMPERATURE

George C. West

Birds maintain relatively constant body temperatures, in general several degrees higher than those of mammals, in spite of external temperatures that range for some species to above 40°C and for others as low as -60°C . The ability to maintain a constant temperature in the face of such thermal extremes is dependent upon the proper coordination and regulation of the mechanisms for heat production and heat loss. A complete understanding of these mechanisms would enable one to obtain a more thorough picture of how birds adapt to their ever changing environments in nature.

The basic principles of thermal exchange in homeotherms have been well reviewed by Hart (1957) and more recently by King and Farner (1961), who have shown that birds behave essentially as heat machines, varying heat gain and heat loss to maintain a constant temperature under all thermal conditions in which they are capable of surviving.

This review will attempt to summarize some of the recent work on the responses of wild birds to temperature, with particular emphasis on the effect of environmental temperature below body temperature and the bioenergetic adaptations of birds to temperature under natural conditions.

Body Temperature

A large number of deep body temperatures have been recorded for adult birds in almost every order (Baldwin and Kendeigh, 1932; Bartholomew and Dawson, 1954; Bartholomew and Cade, 1957; Dawson, 1954; Farner, 1956; Farner et al., 1956; Irving and Krog, 1954,

*Contribution, in part, from the Division of Applied Biology, National Research Council, Ottawa, Canada. Issued as N.R.C. No. 6629.

1955, 1956; Steen and Enger, 1957; Udvardy, 1953, 1955; Wetmore, 1921; and others). The variety of methods used, however, prohibits legitimate comparison in most cases, e.g.: (1) use of a thermocouple or mercury thermometer inserted into the cloaca or proventriculus of a bird held in the hand, (2) use of a thermometer in the cloaca or proventriculus immediately after shooting, (3) use of thermocouples inserted temporarily in the cloaca, (4) use of indwelling thermocouples implanted with the junction under the skin or in the pectoral muscles. The last method will give the most satisfactory results for comparative purposes, especially when temperatures are recorded continuously in the dark at night (for diurnal species) while the bird is at a thermoneutral temperature (near 30°C) and in a post-absorptive condition (King and Farner, 1961). Deep body temperatures obtained under these conditions average about 40.3°C for passerines and 39.5°C for non-passerines.

The core temperatures of birds are relatively constant, and fluctuations in temperature are minimized. The shell, consisting of the skin, feathers, scales, subcutaneous fat, and tissue, including some skeletal muscle, acts as an insulating layer whose rate of thermal conductance can be increased when deep body temperatures rise and decreased when deep body temperatures fall. The distal unfeathered portions of the leg and foot are most important for rapid dissipation of heat (Bartholomew and Dawson, 1958), while the subcutaneous fat and feathers are important for the prevention of heat loss.

Core temperatures of adult diurnal birds increase with gross activity during the day and drop when the bird is at rest during the night. At high and constant ambient temperatures, diurnal fluctuations in body temperature are less pronounced, being about 1°C to 3°C (Bartholomew and Dawson, 1954; Dawson, 1954), while at low ambient temperatures, body temperatures may drop 3°C to 4°C at night below the normal daytime value (Fig. 1).

Temporary hypothermia has been recorded for adult birds in the Caprimulgiformes, Apodiformes and Coliiformes (Bartholomew, Howell, and Cade, 1957) and possibly in two families of the Passeriformes, the Hirundinidae (McAtee, 1947) and the Paridae (Steen,

BIRD ADAPTATIONS

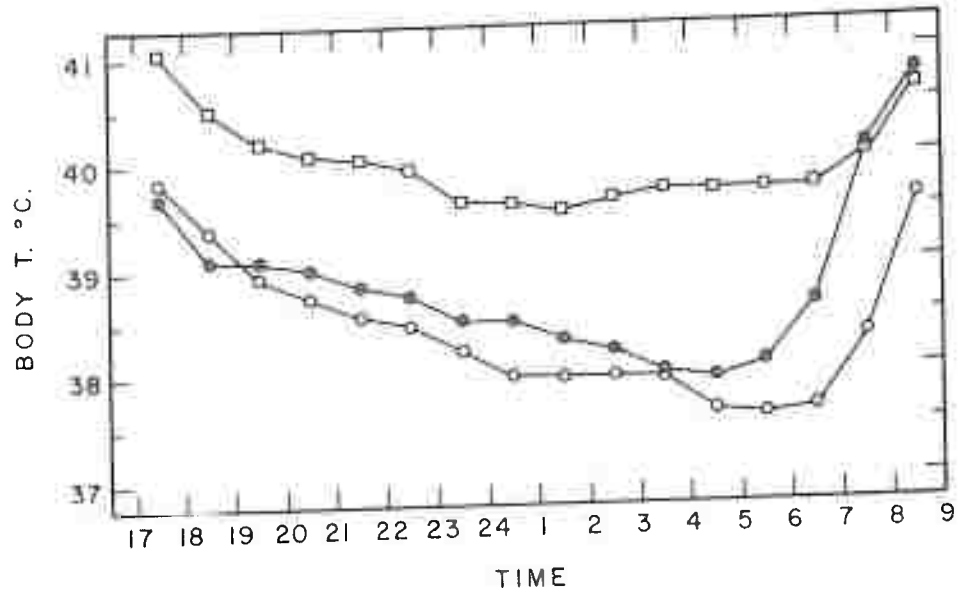

Figure 1. Body temperatures of eight Evening Grosbeaks recorded by indwelling thermocouples at a constant temperature of 30°C (□), a constant temperature of -15°C (○), and outdoors during January at -6.8°C (◇).

1958). It has been observed that nocturnal hypothermia in the cold, such as that recorded by Steen, in small passerines is often due to the birds' inability to adapt to caging and experimental conditions on the first night of capture. Most birds whose body temperatures dropped more than 4°C the first night of capture lost weight or ultimately did not survive (Fig. 2).

Temporary hypothermia is common among the young of most altricial species since they are essentially poikilothermic when hatched and develop homeothermy during the nestling period (Baldwin and Kendeigh, 1932). Body temperatures of these young, therefore, are subject to considerable variation independent of activity or time of day since they are dependent for warmth on the brooding of their parents.

Heat Regulation

Physical Mechanisms. Physical thermoregulation involves alteration in the physical aspects of the shell, increased use of the respiratory surfaces as an avenue of heat loss, and changes in behavior pattern. As the temperature falls below thermoneutrality, birds gradually increase their total insulation until it reaches a maximum level, which is then maintained. According to classical theory, this increase in insulation occurs before an increase in heat production is required (Fig. 3) (Scholander et al., 1950a; Hart, 1957; King and Farner, 1961). Insulation in the cold involves vasoconstriction of peripheral vessels, increase in the insulating ability of the plumage, and behavioral adaptations such as huddling, sitting on legs and feet, "balling up" by putting the head under the wing, burrowing, or roosting in cavities (Kendeigh, 1961a). It is evident that the plumage is the major insulator, since temperatures recorded under the skin are within 0.5°C to 1.0°C of the core temperature (Steen and Enger, 1957; West and Hart, unpublished), and thermocouples placed on the skin under the feathers are also within 1°C to 2°C of the core temperature (Dawson and Tordoff, 1959).

Direct measurements of the insulating ability of the plumage are difficult to make (Scholander et al., 1950b), but calculations of

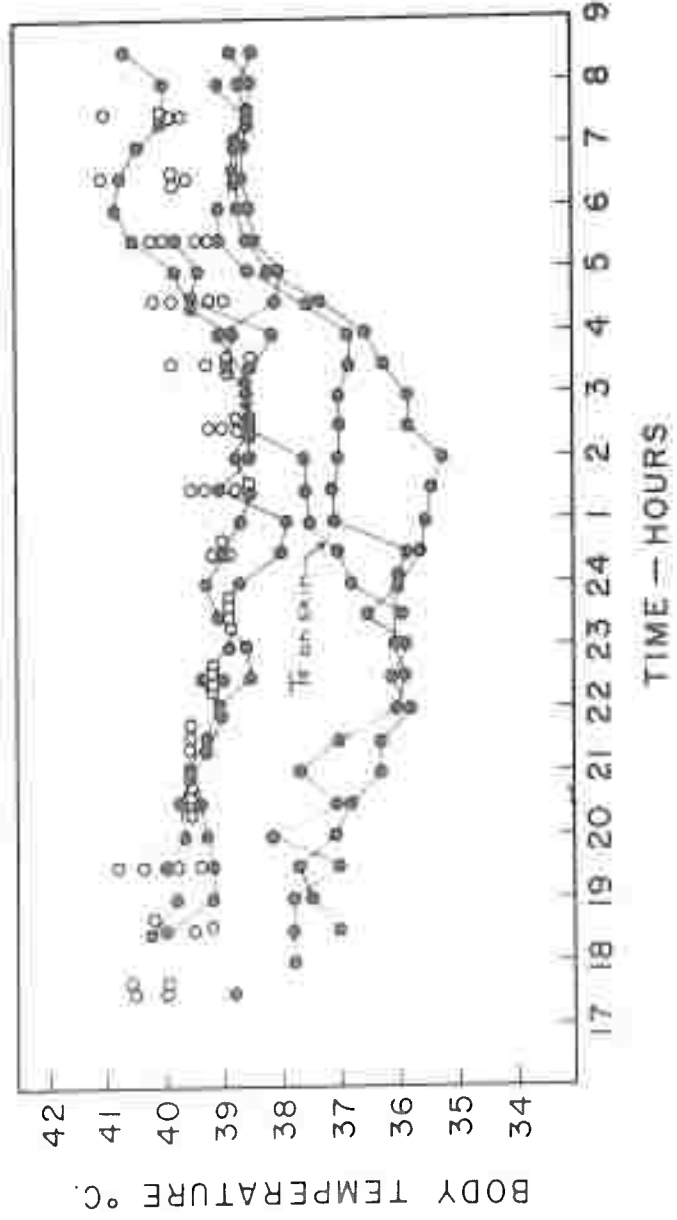

Figure 2. Body temperatures of winter acclimatized Common Redpolls recorded by indwelling thermocouples at an ambient temperature of -10°C . Records of individual birds on the night of capture in March (●) compared with four birds held in captivity out-of-doors until June and recorded at -20°C (○). The lower two records are of birds that died about 9 AM.

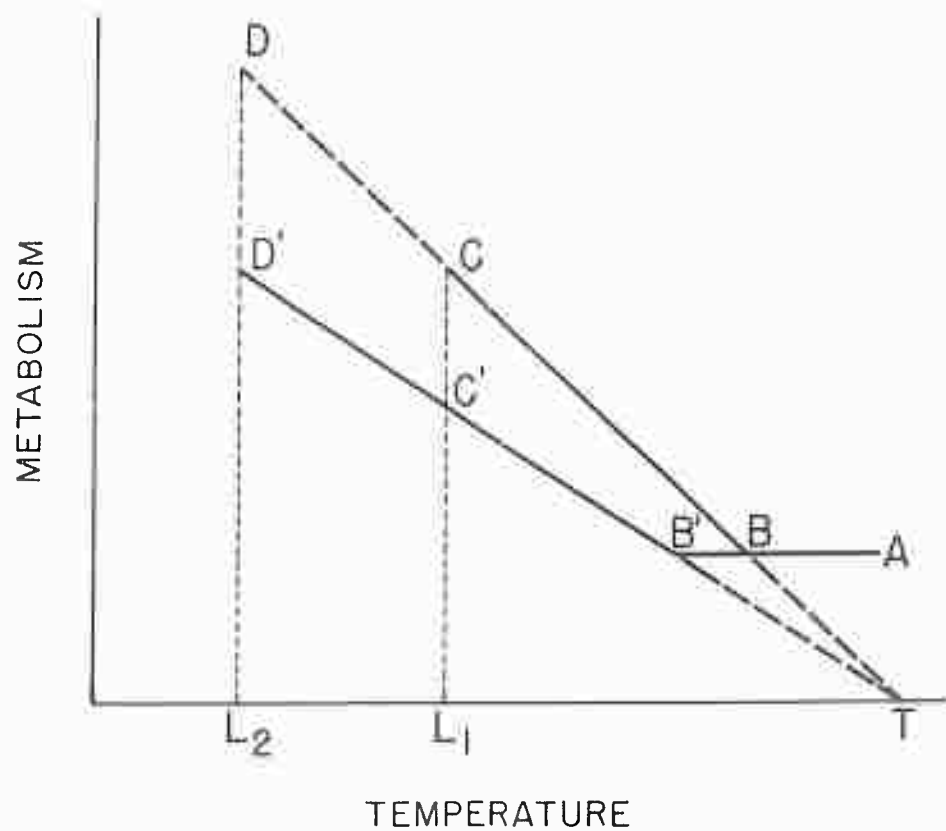

Figure 3. Classical picture of partition of chemical and physical thermoregulation, showing the thermoneutral zone (ABB'), the critical temperature (B, B'), and metabolism slopes (BCD, B'C'D') that extrapolate to body temperature (T). (Hart, 1957).

BIRD ADAPTATIONS

insulating ability have been made for several species of birds at thermoneutrality and at a few lower temperatures (Hart, 1957; Misch, 1960; Wallgren, 1954; West, unpublished). Investigations on the Evening Grosbeak (Hesperiphona vespertina) and calculations based on data in the literature indicate that the total insulation (Body T - Air T/(kcal x bird x hour)) increases gradually as temperature falls (Fig. 4). It can be readily observed that the insulation increase is almost linear for some species (Tree Sparrow, Spizella arborea), but a curve for most. The highest temperature at which insulation reaches its maximum is 0° C in both the Cardinal (Richmondia cardinalis) and the Evening Grosbeaks studied by Dawson and Tordoff (1959), while many species continue increasing their insulation to the lowest test temperature (House Sparrow, Passer domesticus, and Variable Seedeater, Sporophila aurita).

Conservation of heat at cold temperatures by peripheral blood flow control and vascular heat exchange in non-insulated portions of the body has been demonstrated in the Glaucous-winged Gull (Larus glaucescens) (Irving and Krog, 1955) and in many other species (Bartholomew and Dawson, 1954; Bartholomew and Cade, 1957; Scholander, 1955).

At air temperatures approaching body temperature, insulation is decreased to its minimum, and mechanisms for dissipation of heat are invoked. These include increase in peripheral blood flow to the legs and feet, increased ventilation, evaporation from the respiratory surfaces, and panting. Some birds are able to increase the temperatures of their legs and feet and still maintain a favorable gradient for heat loss even at temperatures above body temperature (Bartholomew and Dawson, 1958). Birds living in hot regions have evolved behavior patterns enabling them to avoid the heat of day.

Metabolic mechanisms. Thermogenesis in response to cold occurs chiefly by increased physical activity such as exercise, increased muscle tone, and shivering. The heat produced by the specific dynamic action of digestion and assimilation may help to maintain body temperature, but evidence for this is lacking in wild birds (King and Farner, 1961). Non-shivering thermogenesis has been

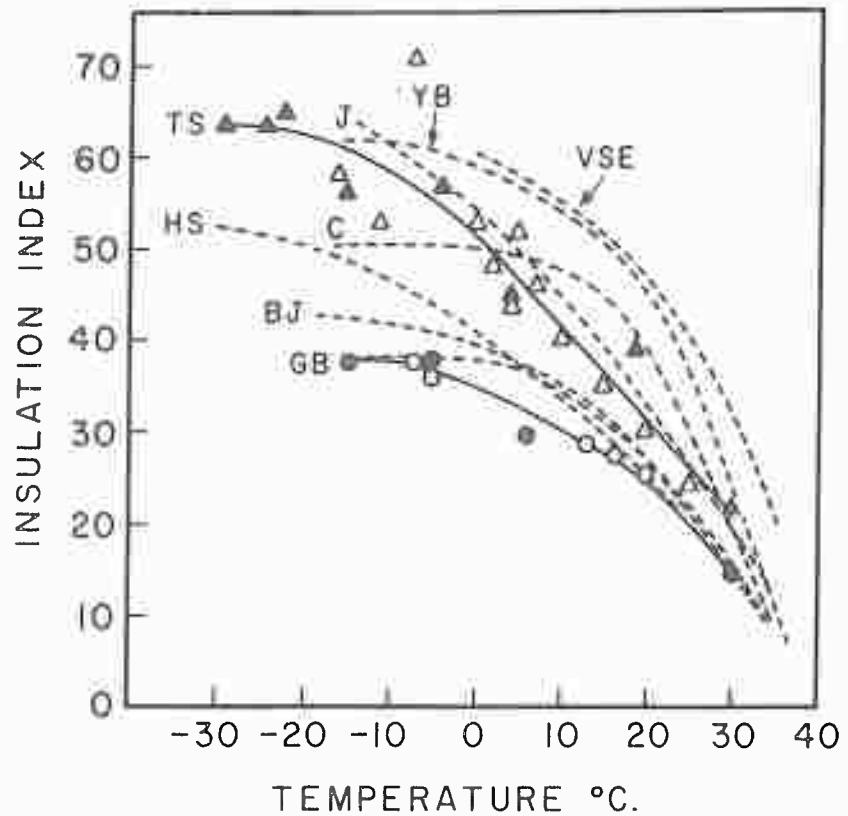

Figure 4. Insulation indices calculated by the formula:

$$\frac{\text{Body } T^{\circ} \text{C} - \text{Air } T^{\circ} \text{C}}{\text{kcal/bird/hour}}$$

Average indices of birds held at constant temperature (●,▲); and of birds under natural fluctuating conditions (○,△). TS=Tree Sparrow (West, 1960), GB=Evening Grosbeak (West and Hart, unpublished). The dashed lines are values calculated from the literature: J=Slate-colored Junco (Seibert, 1949); YB=Yellow Bunting (Wallgren, 1954); VSE=Variable Seedeater (Cox, 1961; C=Cardinal (Dawson, 1958); HS=House Sparrow (Kendeigh, 1949); BJ=Blue Jay (Misch, 1960); GB=Evening Grosbeak (Dawson and Tordoff, 1959).

BIRD ADAPTATIONS

described for the white rat (Cottle and Carlson, 1956), but the few experiments done by Hart (in press) indicate that curarized pigeons (*Columba livia*) are not able to increase their metabolism in the cold.

Recent work by Steen and Enger (1957) on pigeons and by West (unpublished) on Evening Grosbeaks and Common Redpolls indicate that shivering is the major source of heat production by birds in the cold. Experiments on the Evening Grosbeak show that these birds shiver all night out-of-doors at all temperatures below thermoneutrality in both summer and winter. The intensity of shivering increases as the ambient temperature falls (Fig. 5).

Since shivering in particular and metabolic thermoregulation in general are achieved by an increase in energy expenditure, it is pertinent to review some of the recent work on energy exchange in wild birds.

Indirect calorimetric measurements of heat production can be made either by recording the respiratory exchange of oxygen and carbon dioxide or by recording food consumption and excrement production. Although the first method has been widely used by most workers, it is limited in that metabolic rates are sampled over relatively short periods of time. Both "open circuit" and "closed circuit" apparatus have been employed, the latter being further restricted because the ambient temperature must remain constant. Energy balance studies such as those used by Kendeigh (1949), Seibert (1949), Davis (1955), King and Farner (1956), West (1960), and Cox (1961) for wild birds yield an average metabolic level over a period of several days. However, this method is not able to distinguish between metabolic levels at different times of the day.

Automatic recording oxygen and carbon dioxide analyzers have been successfully used to record oxygen consumption and carbon dioxide production simultaneously for 2 to 3 days at a time on wild birds. The birds live in small cages and are supplied with food and drink *ad libitum*. Daytime and nighttime values can easily be obtained by examining selected portions of the record (Fig. 6). Another advantage of this system is that the birds are not disturbed once the

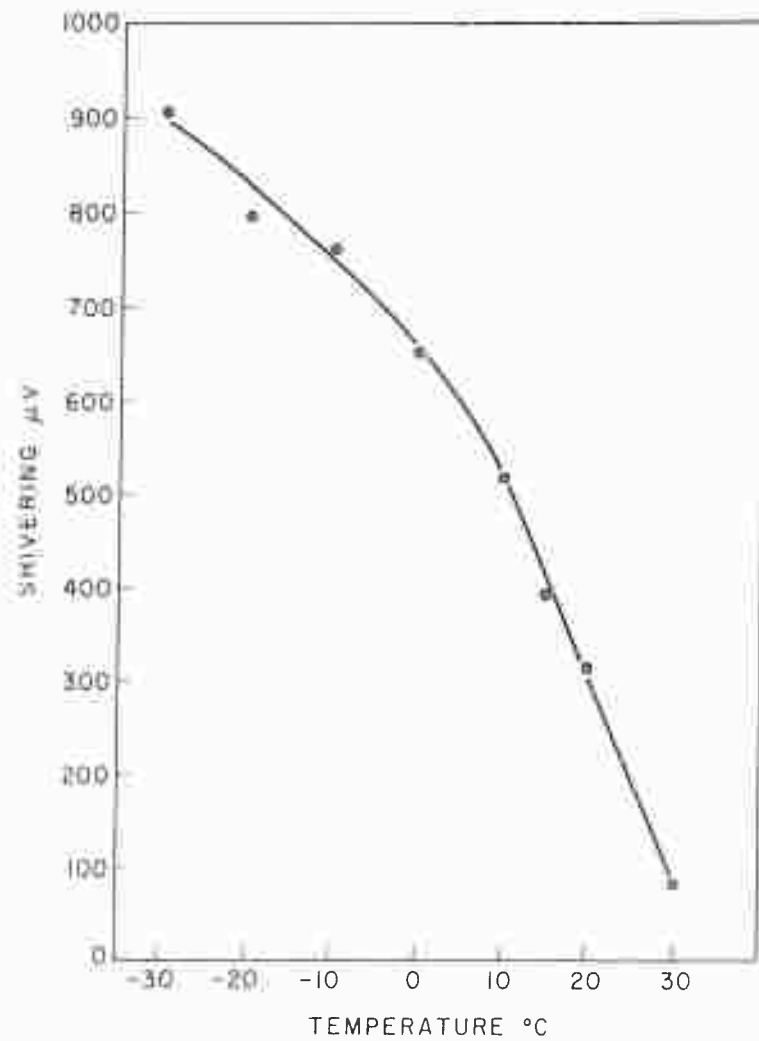

Figure 5. Shivering of summer acclimatized Common Redpolls recorded in microvolts during short term exposure at each temperature. Each point represents averages of four birds.

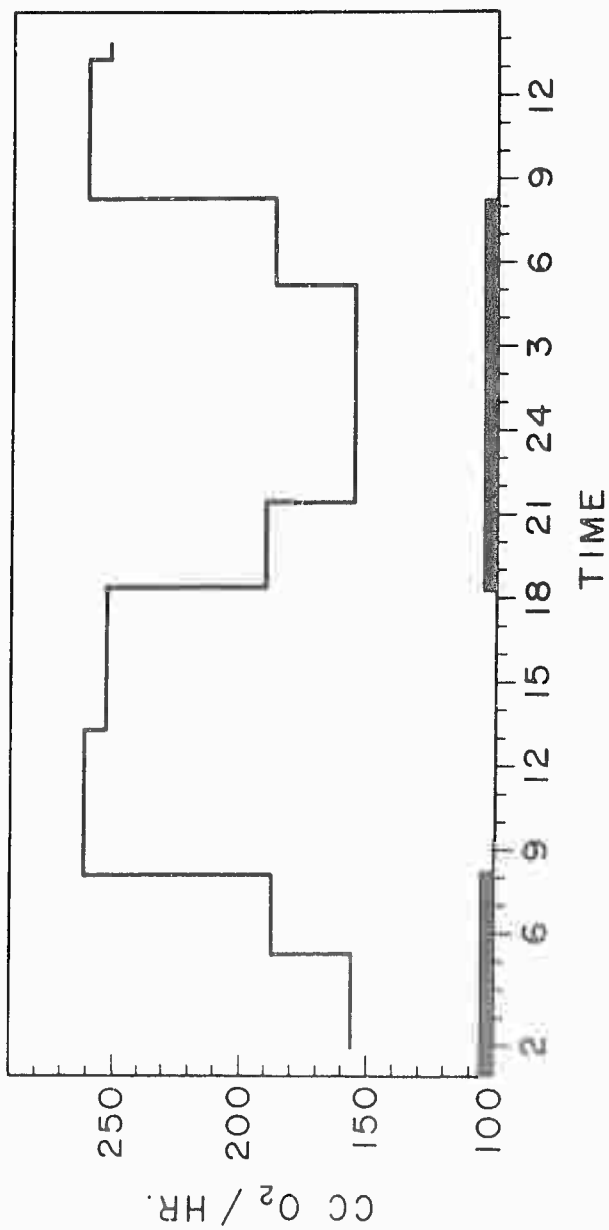

Figure 6. Average diurnal changes in oxygen consumption of eight Evening Grosbeaks recorded for four consecutive days at a constant temperature of 18° C.

experiment is under way. We have observed that metabolic rates remain elevated for about 1 hour after the birds have been placed in a darkened metabolism chamber (West and Hart, unpublished).

Previous thermal history affects the metabolism of an animal at any given test temperature. In order to test the effect of ambient temperature on metabolism, it has been customary to follow one of two methods: (1) Birds are acclimated to a single constant temperature of season and then metabolism values are obtained at a series of test temperatures (Scholander et al., 1950a; Wallgren, 1954; Irving et al., 1955; Steen, 1957; Dawson, 1958; Dawson and Tordoff, 1959; Misch, 1960; Hart, in press; West and Hart, unpublished; and others). (2) Birds are acclimated and their metabolism measured at a single temperature; the temperature is changed and the birds are acclimated and run again, etc. (Kendeigh, 1949, Seibert, 1949; Davis, 1955; Rautenberg, 1957; West, 1960; Cox, 1961; and others).

Many workers have assumed that a linear regression line fitted to the metabolism values at a series of temperatures must extrapolate to body temperature according to Newton's law of cooling (Scholander et al., 1950a; Steen, 1957; and others). This interpretation results in a distinct thermoneutral zone and a critical temperature which divides physical from chemical thermoregulation. Most of the results on small birds obtained by these workers can be equally well interpreted as either a straight line drawn through all points, thus eliminating the critical temperature and thermoneutral zone completely (Fig. 7) or as a curve, which also eliminates the definition of a single critical temperature. The latter interpretation has been suggested by Dawson (1958) for his data on the Cardinal (Fig. 8), and by Dawson and Tordoff (1959) for the Evening Grosbeak.

The slopes obtained by workers measuring metabolism over 24 hour periods are in general much flatter than those obtained in short-term tests on non-acclimated birds. They show no thermoneutral zone, no critical temperature; and the temperature vs. metabolism slope does not extrapolate to body temperature (Fig. 9). Studies in progress on the Evening Grosbeak indicate that the flat slopes may be explained by marked differences in diurnal and nocturnal metabolism and levels of motor activity that change with

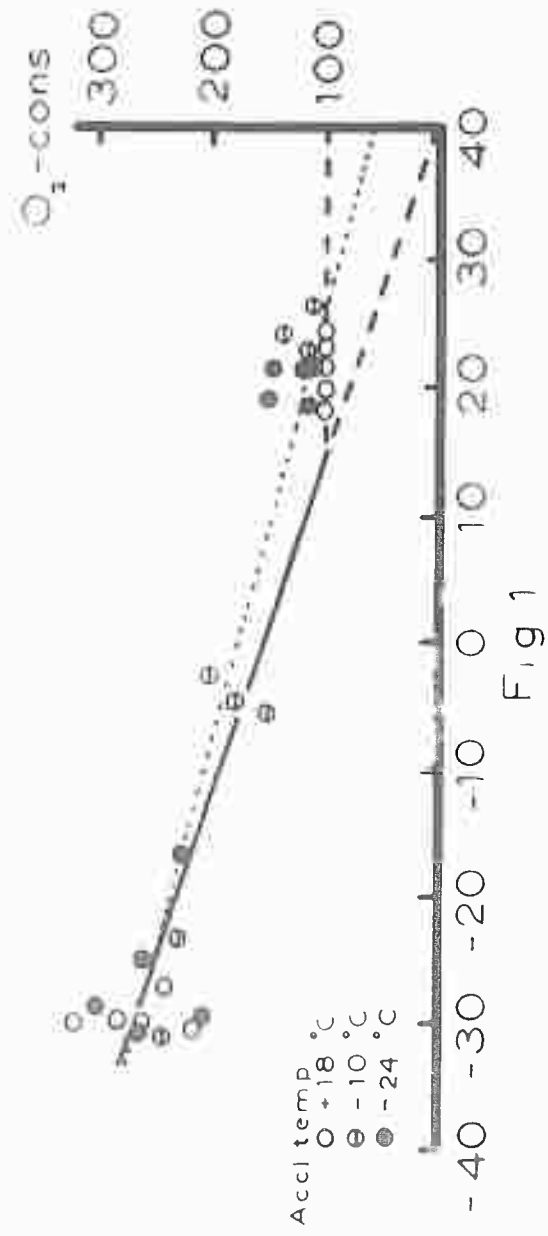

Figure 7. Oxygen consumption of Pigeons at various temperatures. Modified from Steen (1957).

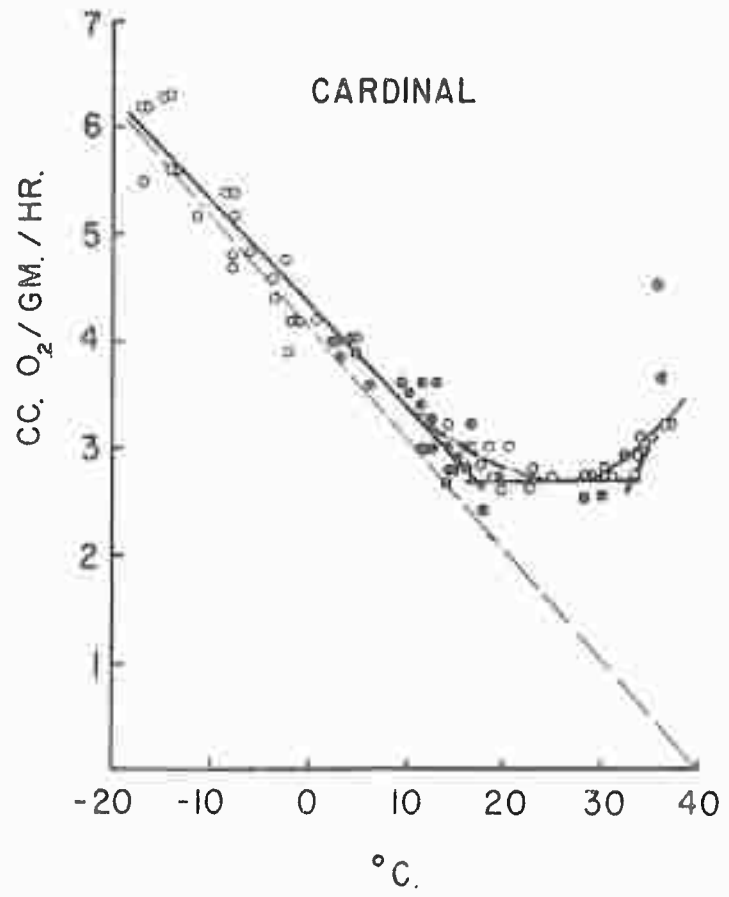

Figure 8. Oxygen consumption of Cardinals at various temperatures. Modified from Dawson (1958). (Courtesy of University of Chicago Press, copyright holder).

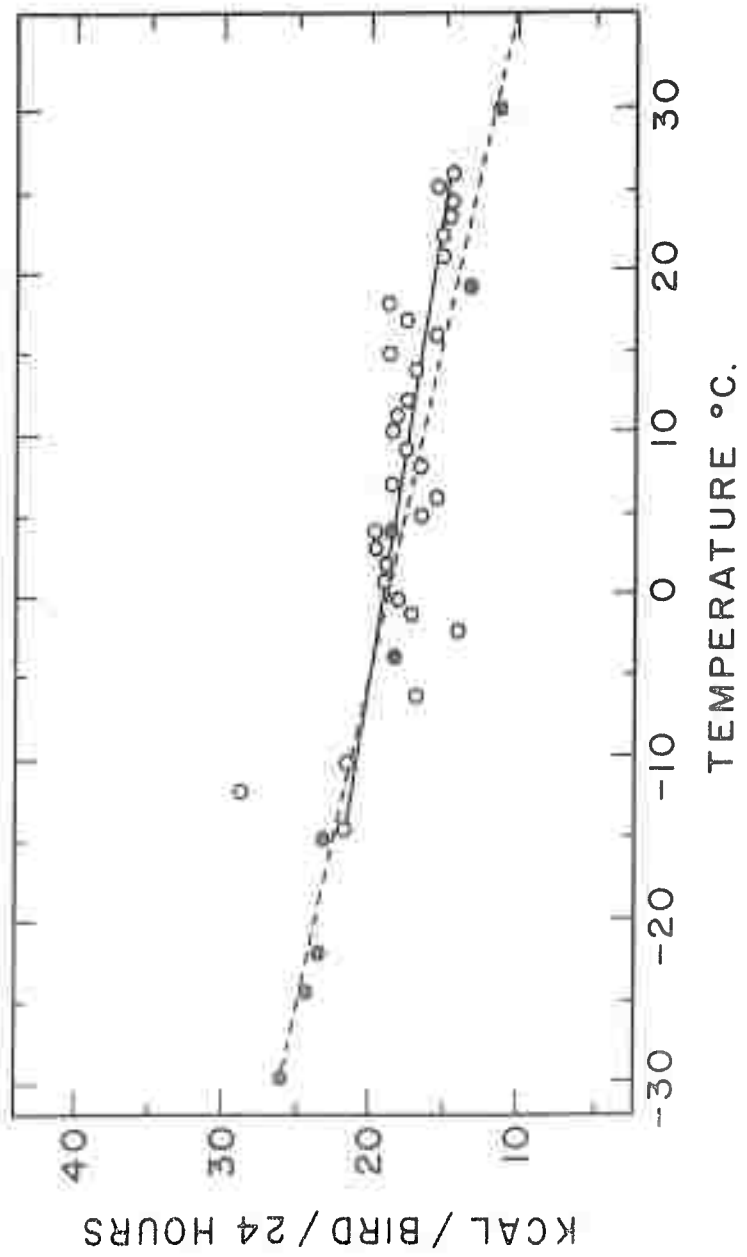

Figure 9. Metabolized energy of Tree Sparrows kept under constant conditions (●), and under naturally fluctuating outdoor conditions (○). Data from West (1958).

ambient temperature (West and Hart, unpublished).

It seems reasonable from the available data that most small wild birds have a curvilinear relationship of metabolism to temperature (Fig. 10). The data in Figure 4 indicate that most birds increase their insulation gradually from high to low temperatures, rapidly at first, then leveling off as maximum insulation is achieved. Heat production, however, increases slowly at first, but then proceeds faster as metabolic mechanisms become the only method of maintaining homeothermy at the lower temperatures. The slope of the curve at the lower temperatures extrapolates to body temperature according to Newton's law of cooling. However, the upper portion of the temperature-metabolism curve extrapolates beyond body temperature since both insulative and metabolic mechanisms are operating simultaneously. Therefore, a prolonged thermoneutral zone and a definite critical temperature probably do not exist for wild birds.

Acclimation and Acclimatization

Gelineo (1955) acclimated birds to three constant temperatures and then obtained metabolism values at a series of test temperatures for each acclimation group. In most cases the cold acclimated birds had a higher metabolism slope and thermoneutral metabolism than the warm acclimated birds (Fig. 11). Similar results have been obtained by Miller (1939) for House Sparrows, Dontcheff and Kayser (1934) and Steen (1957) for the Pigeon, and Wallgren (1954) for the Ortolan (Emberiza hortulana) and Yellow Bunting (Emberiza citrinella).

Contrary to the results obtained with temperature conditioned birds, most species acclimatized to summer and winter seasons do not show differences in their standard metabolisms or in their temperature metabolism slopes (Kendeigh, 1949, and Davis, 1955, for the House Sparrow (Fig. 12); Wallgren, 1954, for the Yellow Bunting; Irving et al., 1955, for the Black Brant (Branta nigricans); Rautenberg, 1957, for the House Sparrow and Brambling (Fringilla montifringilla); Dawson, 1958, for the Cardinal; Hart, in press, for the Pigeon, House Sparrow, Evening Grosbeak, and Starling

BIRD ADAPTATIONS

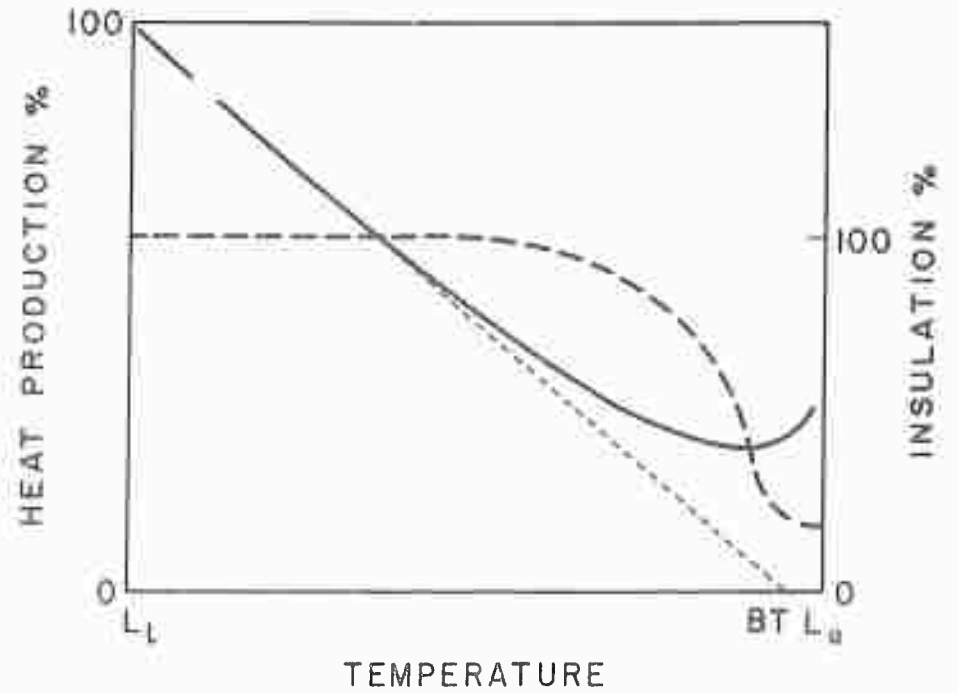

Figure 10. Overlap of insulative (dashed line) and metabolic (solid line) adjustments for thermoregulation in small wild birds. After insulation reaches its maximum, increases in metabolism carry the bird to its lower limit of tolerance (L_l). This slope extrapolates to body temperature (BT) according to Newton's law of cooling. Above body temperature, metabolism increases, and insulation reaches its minimum as the upper limit of tolerance is reached (L_u).

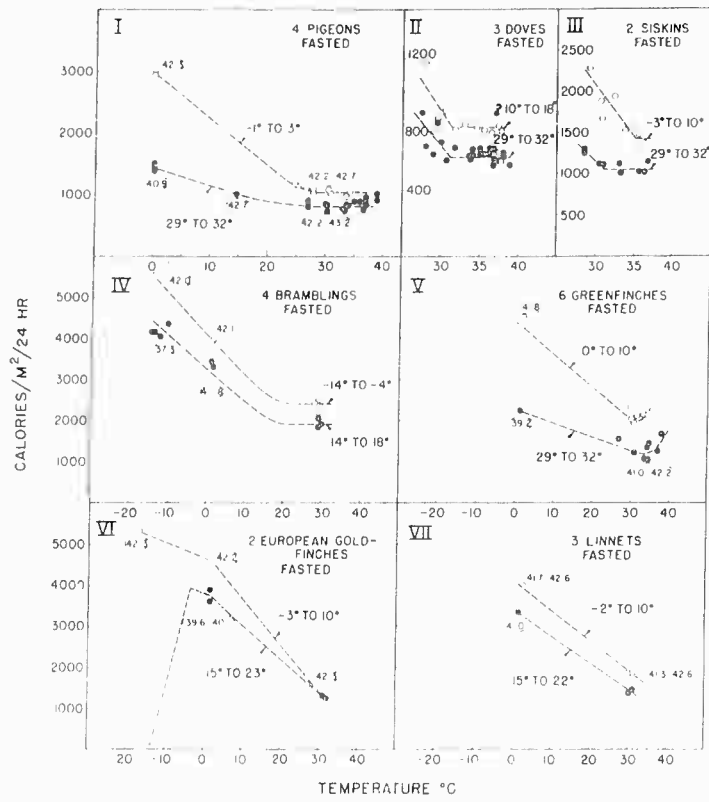

Figure 11. Temperature-metabolism curves of birds acclimated to warm (●) and cold (○). Gelmeo's data replotted by Hart (1957).

BIRD ADAPTATIONS

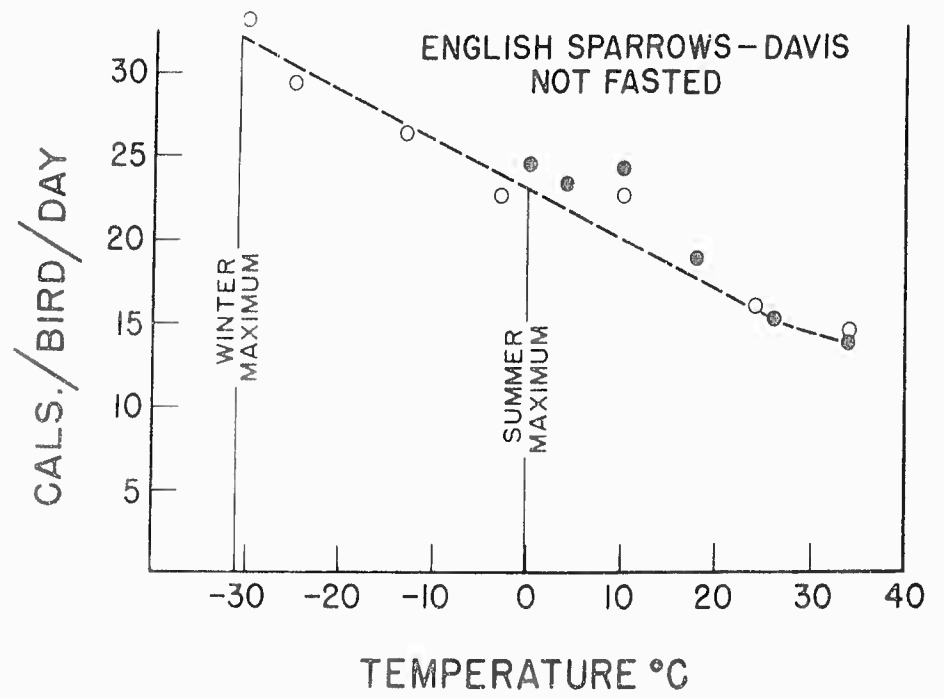

Figure 12. Metabolized energy of winter (○) and summer (●) acclimatized House (English) Sparrows. Davis' data replotted by Hart (1957).

(*Sturnus vulgaris*). The reason for the difference in metabolic response between laboratory acclimated and seasonal acclimatized birds may be that the temperature conditioning process is suppressed by variable ambient temperatures (King and Farner, 1961).

The ability of birds to tolerate low temperature extremes is one of the best indications of seasonal metabolic acclimatization. The work of Kendeigh (1949), Seibert (1949), and Davis (1955) clearly shows that the House Sparrow can extend its low temperature tolerance limit from 0°C in the summer to -31°C in the winter (Fig. 12). In contrast, the Tree Sparrow does not change its lower limit of tolerance and survives to -28°C in both summer and winter (West, 1960). The ability to tolerate low temperatures depends primarily on the length of time that the birds can maintain their maximum metabolic rates. By subjecting seasonally acclimatized birds to a single low temperature, Hart (in press) shows that winter acclimatized Evening Grosbeaks, Starlings, and Pigeons can maintain their maximum metabolic rates for longer periods of time than summer acclimatized birds.

In addition to increased metabolic capacity during the winter, there may be a seasonal shift in insulation since Kendeigh (1934) showed a 29% increase in plumage weights of winter over summer House Sparrows, and West (1960) an increase of 25% of winter over summer plumage weights of Tree Sparrows.

Many species of birds exhibit annual cyclic thyroid activity while others do not (Wilson and Farner, 1960). Wilson and Farner show a direct correlation between thyroid activity and ambient temperature in the Gambel's White-crowned Sparrow (*Zonotrichia leucophrys gambelii*). These birds experienced an annual temperature cycle of at least 20°C (0°C to 20°C) in eastern Washington. Simultaneously, Oakeson and Lilley (1960) studied the same race of White-crowned Sparrow both on its wintering ground in California and on its breeding ground in Alaska and in contrast, found no annual change in thyroid activity. Wilson and Farner explain this difference by showing that the amplitude of the cycle of temperature that Oakeson and Lilley's birds experienced was probably about 5°C , 15°C less annual variation than their own birds received.

This brings out an interesting correlation between thyroid activity and metabolic acclimatization in migrant and non-migrant species. From the data cited above and from those of Miller (1939), it may be observed that permanent resident species have pronounced thyroid cycles and therefore greater degrees of metabolic acclimatization because they experience pronounced annual fluctuations in temperature, while migrants, such as the Tree Sparrow or the White-crowned Sparrow studied by Oakeson and Lilley do not have cyclic changes in thyroid activity and therefore little change in metabolic acclimatization because they experience similar temperature conditions in both winter and summer.

Ecological Implications

The physical and metabolic thermoregulatory mechanisms possessed by a species enables it to adapt to a specific set of environmental conditions, i.e., its distribution is limited by these mechanisms. The habitation of any area is determined in part by the ability of a species to acquire not only enough existence energy, but also sufficient productive energy (Kendeigh, 1949) for carrying on energy demanding activities such as molting, reproduction, and migration. In addition to these physiological limits, morphological and behavioral adaptations impose further restrictions on the actual distribution of a species. Although thermoregulatory adaptations to specific environments are covered elsewhere in this symposium, it is important to discuss some of the energy requirements for existence and other activities under natural conditions.

The energy intake of all small wild birds yet studied increases in the winter. The added energy intake is used for existence, which includes maintenance of homeothermy and body weight, acquiring food and drink, the SDA of digestion and assimilation (Kendeigh, 1949), and the deposition of body fat. The added fat may be an emergency measure against severe winter weather or an aid in total insulation. Permanent resident species of temperate regions, such as the House Sparrow, maintain favorable energy conditions throughout the year by increasing their ability to metabolize energy in the cold (see above). Permanent residents of tropical regions, such as the

Variable Seedeater, Yellow-bellied Seedeater (Sporophila nigricollis), Blue-black Grassquit, (Volatinia jacarina), and Green-backed Sparrow (Arremonops conirostris), need vary their energy intake for existence only slightly, with minor changes in temperature and photoperiod throughout the year (Cox, 1960).

Migrant species, however, must adjust to the climatic conditions of two localities. Arctic and temperate breeding birds attain more nearly uniform environmental temperatures by migrating to southern latitudes in the winter. Therefore, the lack of metabolic acclimatization in the Tree Sparrow (see above) may be a result of spending the whole year in a relatively constant climate.

In contrast to permanent resident species, migrant birds must increase their energy intake for migratory flights in the spring and fall (Farner, 1955; Rautenberg, 1957; Kendeigh et al., 1960). The added energy intake is used for the deposition of migratory fat, and in caged birds, for motor activity at night (Zugunruhe). When fat stores are completed and weather conditions are satisfactory, actual flight, utilizing the stored fat, occurs. The pattern of added energy intake for fat deposition alternated with migratory flights is repeated until the final destination is reached (Wolfson, 1954). The added cost of fat deposition and spring nocturnal unrest increases the daily energy intake of White-crowned Sparrows by 30% to 50% (King and Farner, 1956) and the intake of Tree Sparrows by 21% to 22% (West, 1960; Kendeigh et al., 1960).

Following migration, reproductive activities are initiated. The amount of energy required to produce a clutch of eggs is undoubtedly considerable although it has not been experimentally determined for wild birds (Kendeigh, 1941). The added cost of incubation of eggs by the female Tree Sparrow has been calculated to add about 22% to its existence energy requirement per day (West, 1960). Kendeigh (1961b) shows that incubating House Wrens (Troglodytes aedon) also require 23% more energy while incubating.

Most small passerines have a complete post nuptial molt in the fall. The growth of new feathers requires energy. Metabolic rates of the Chaffinch (Fringilla coelebs) (Koch and deBont, 1944)

BIRD ADAPTATIONS

Yellow Buntings and Ortolans (Wallgren, 1954) increased 10% to 26% during molting. The increases, however, are variable, and it appears that the greatest energy cost occurs during growth of the large flight feathers of the wing and tail (Koch and deBont, 1944). It is doubtful that the gradual loss and replacement of feathers causes a measureable lowering of body insulation in most passerines, and any metabolic increase, therefore, is due to the production of new feathers (King and Farner, 1961).

Davis (1955) did not find an increase in metabolized energy of House Sparrows during molting, although his data exhibited greater variability at this time. King and Farner (1961) have pointed out that the added daily cost of producing new feathers is so small that it might not be detected in food consumption experiments. West (1960), however, found a 27% increase in metabolized energy of molting Tree Sparrows for over one week. This may have been during the time of flight feather regeneration and an average value over several weeks might be lower.

When the values for fat deposition, migration, reproduction, and molting are added to the daily existence level, the total energy expenditure of a single species can be traced throughout the year (Fig. 13). The added cost of living a free existence as opposed to a caged existence may be greater in the winter than in the summer due to the difficulty of finding food. The uniform spacing of energy demanding activities is such that the average daily intake of energy is about the same throughout the year.

A species must be confined to localities where it can secure enough energy not only for existence, but also for all its essential activities. Therefore, climate, and particularly temperature, plays a major role in controlling distribution by excluding species from regions which impose energy requirements exceeding metabolic capabilities.

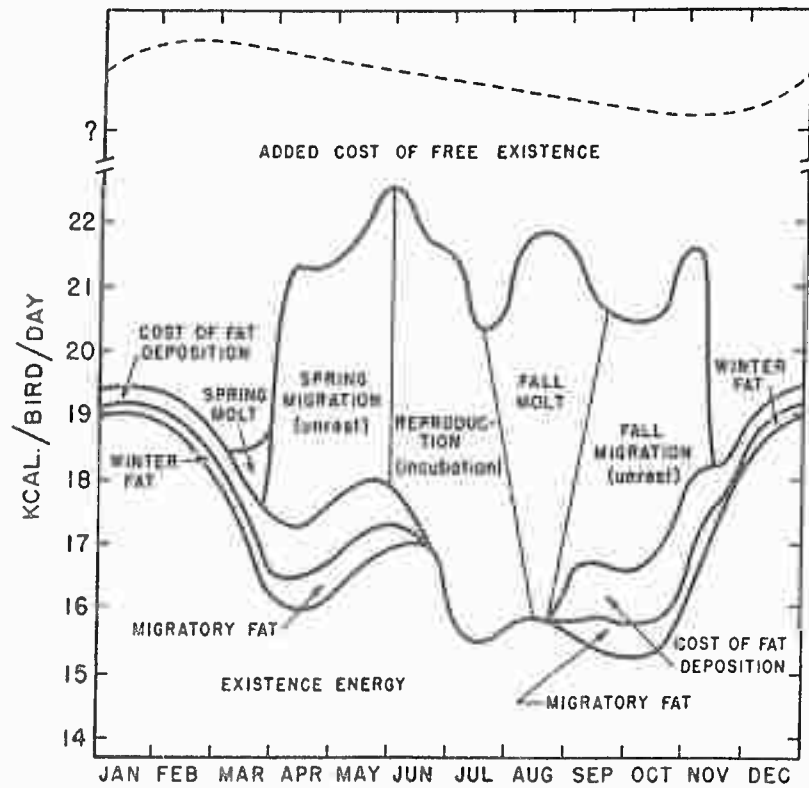

Figure 13. Total energy requirements of Tree Sparrows throughout the year. The lowest curve is that of existence energy to which the energy required by various activities has been added (West, 1960).

BIRD ADAPTATIONS

SUMMARY

Birds maintain relatively constant body temperatures by regulating mechanisms for heat production and heat loss over a wide range of environmental temperatures.

The variable insulative ability of the plumage is the chief mechanism for prevention of heat loss. As temperature falls, insulation gradually increases until it reaches a maximum. At the same time, peripheral circulation decreases and heat is retained in the core of the body. Simultaneous with the increase in insulation, shivering increases as the ambient temperature drops. After the insulation reaches its maximum, metabolic mechanisms alone maintain homeothermy until the lower limit of temperature tolerance is reached. In most small passerines, the total effect of combined insulation and shivering responses to temperature results in a curvilinear relationship of metabolism to temperature, with no prolonged thermoneutral zone indicated.

Birds acclimated to low constant temperatures in the laboratory generally have higher metabolic rates at any temperature than those acclimated to warm temperatures. Birds acclimatized to different seasons, however, show little change in metabolic response at thermoneutral temperatures. Seasonal changes in thermoregulatory mechanisms involve an increased ability to produce heat by increasing the metabolic rate in the cold of winter for extended periods of time and possibly an increase in the amount of plumage insulation.

Existence energy requirements of small wild birds living in temperate regions are increased in the winter. Permanent residents may have a more pronounced seasonal difference in their ability to tolerate low temperatures than migrant species since they encounter greater extremes of temperature.

The added daily cost of nocturnal unrest and of depositing migratory fat differs slightly among migrant birds according to the length of time spent in premigratory preparation and in the average

WEST

length of each migratory flight. The average daily intake of small birds probably remains relatively constant throughout the year, since energy demanding activities such as existence in winter cold, deposition of fat, migration, reproduction, and molting are uniformly spaced. The distribution of a species is therefore limited to locations where the climate permits fulfillment of all essential energy demanding activities.

BIRD ADAPTATIONS

LITERATURE CITED

1. Baldwin, S. P. and S. C. Kendeigh. 1932. Physiology of the temperature of birds. Sci. Publ. Cleveland Museum Nat. Hist. 3:1-196.
2. Bartholomew, G. A. and T. J. Cade. 1957. The body temperature of the American Kestrel. Falco sparverius. Wilson Bull. 69: 149-154.
3. Bartholomew, G. A. and W. R. Dawson. 1954. Body temperature and water requirements of the Mourning Dove, Zenaidura macroura marginella. Ecology 35:181-187.
4. Bartholomew, G. A. and W. R. Dawson. 1958. Body temperatures in California and Gambel's Quail. Auk 75:150-156.
5. Bartholomew, G. A., T. R. Howell, and T. J. Cade. 1957. Torpidity in the White-throated Swift, Anna Hummingbird, and the Poorwill. Condor 59:145-155.
6. Cottle, W. H. and L. D. Carlson. 1956. Regulation of heat production in cold-adapted rats. Proc. Soc. Exp. Biol. and Med. 92:845-849.
7. Cox, G. W. 1961. The relation of energy requirements of tropical finches to distribution and migration. Ecology 42:253-266.
8. Davis, E. A., Jr. 1955. Seasonal changes in the energy balance of the English Sparrow. Auk 72:385-411.
9. Dawson, W. R. 1954. Temperature regulation and water requirements of the Brown and Abert Towhees, Pipilo fuscus and Pipilo aberti. Univ. Calif. (Berkeley) Publs. Zool. 59:81-124.

10. Dawson, W. R. 1958. Relation of oxygen consumption and evaporative water loss to temperature in the Cardinal. *Physiol. Zool.* 31:37-48.
11. Dawson, W. R. and H. B. Tordoff. 1959. Relation of oxygen consumption to temperature in the Evening Grosbeak. *Condor* 61:388-396.
12. Dontcheff, L. and C. Kayser. 1934. Le rythme saisonnier de metabolisme de base chez le pigeon en fonction de la temperature moyenne de milieu. *Ann. physiol. physicochim. biol.* 10:285-300.
13. Farner, D. S. 1955. The annual stimulus for migration: experimental and physiological aspects, p. 198-237. In Welfson's Recent studies in avian biology.
14. Farner, D. S. 1956. Body temperature of the Fairy Prion (Pachyptila turtur) in flight and at rest. *J. Appl. Physiol.* 8:546-548.
15. Farner, D. S., N. Chivers, and T. Riney. 1956. The body temperature of North Island Kiwis. *Emu* 56:199-206.
16. Gelineo, S. 1955. Temperature d'adaptation et production de chaleur chez les oiseaux de petite taille. *Arch. sci. physiol.* 9:225-243.
17. Hart, J. S. 1957. Climatic and temperature induced changes in the energetics of homeotherms. *Rev. can. biol.* 16:133-174.
18. Irving, L. and J. Krog. 1954. Body temperatures of arctic and subarctic birds and mammals. *J. Appl. Physiol.* 6:667-680.
19. Irving, L. and J. Krog. 1955. Skin temperature in the arctic as a regulator of heat. *J. Appl. Physiol.* 7:354-363.
20. Irving, L. and J. Krog. 1956. Temperature during the development of birds in arctic nests. *Physiol. Zool.* 29:195-205.

BIRD ADAPTATIONS

21. Irving L., H. Krog, and M. Monson. 1955. The metabolism of some Alaskan animals in winter and summer. *Physiol. Zool.* 28:173-185.
22. Kendeigh, S. C. 1934. The role of environment in the life of birds. *Ecol. Monographs* 4:299-417.
23. Kendeigh, S. C. 1941. Length of day and energy requirements for gonad development and egg-laying in birds. *Ecology* 22: 237-248.
24. Kendeigh, S. C. 1949. Effect of temperature and season on the energy resources of the English Sparrow. *Auk* 66:113-127.
25. Kendeigh, S. C. 1961a. Energy conserved by birds roosting in cavities. *Wilson Bull.* 78:140-147.
26. Kendeigh, S. C. 1961b. The energy cost of incubation. MS.
27. Kendeigh, S. C., G. C. West, and G. W. Cox. 1960. Annual stimulus for spring migration in birds. *Animal Behaviour* 8:180-185.
28. King, J. R. and D. S. Farner. 1956. Bioenergetic basis of light-induced fat deposition in the White-crowned Sparrow. *Proc. Soc. Exp. Biol. and Med.* 93:354-359.
29. King, J. R. and J. S. Farner. 1961. Energy metabolism, thermoregulation and body temperature, p. 215-288. In Marshall's *Biology and Comparative Physiology of Birds*.
30. Koch, H. J. and A. F. deBont. 1944. Influence de la mue sur l'intensite de metabolisme chez le pinson, Frinsilla coelebs coelebs. *L. Ann. Soc. zool. Belg.* 75:81-86.
31. McAtee, W. L. 1947. Torpidity in birds. *Am. Midland Naturalist* 38:191-206.

WEST

32. Miller, D. S. 1939. A study of the physiology of the sparrow thyroid. *J. Exp. Zool.* 80:259-281.
33. Misch, M. S. 1960. Heat regulation in the Northern Blue Jay, Cyanocitta cristata bromia Oberholser. *Physiol. Zool.* 33: 252-259.
34. Oakeson, B. B. and B. R. Lilley. 1960. Annual cycle of thyroid histology in the races of White-crowned Sparrow. *Anat. Rec.* 136:41-57.
35. Rautenberg, W. 1957. Vergleichende Untersuchungen über den Energie haushalt des Bergfinken (Fringilla montifringilla L.) und des Haussperlings (Passer domesticus L.), *J. Ornithol.* 98:36-64.
36. Scholander, P. F. 1955. Evolution of climatic adaptations in homeotherms. *Evolution* 9:15-26.
37. Scholander, P. F., R. Hoch, V. Walters, F. Johnson, and L. Irving. 1950a. Heat regulation in some arctic and tropical mammals and birds. *Biol. Bull.* 99:237-258.
38. Scholander, P. F., V. Walters, R. Hoch, and L. Irving. 1950b. Body insulation of some arctic and tropical mammals and birds. *Biol. Bull.* 99:225-236.
39. Seibert, H. C. 1949. Difference between migrant and non-migrant birds in food and water intake at various temperatures and photoperiods. *Auk* 66:128-153.
40. Steen, J. 1957. Food intake and oxygen consumption in pigeons at low temperatures. *Acta Physiol. Scand.* 39:22-26.
41. Steen, J. 1958. Climatic adaptation in some small northern birds. *Ecology* 39:625-629.
42. Steen, J. and P. S. Enger. 1957. Muscular heat production in pigeons during exposure to cold. *Am J. Physiol.* 191:157-158.

BIRD ADAPTATIONS

43. Udvardy, M. D. F. 1953. Contribution to the knowledge of body temperature in birds. *Zool. Bidvag. Uppsala* 30:25-42.
44. Udvardy, M. D. F. 1955. Body temperature of parids in the arctic winter. *Ornis Fennica*. 32:101-107.
45. Wallgren, H. 1954. Energy metabolism of two species of the genus Emberiza as correlated with distribution and migration. *Acta Zool. Fennica* 84:1-110.
46. West, G. C. 1958. Seasonal variation in the energy balance of the tree sparrow in relation to migration. Ph. D. Thesis, Univ. of Illinois, Urbana.
47. West, G. C. 1960. Seasonal variation in the energy balance of the tree sparrow in relation to migration. *Auk* 77:306-329.
48. Wetmore, A. 1921. A study of the body temperature of birds. *Smithsonian Misc. Coll.* 72(12):51pp.
49. Wilson, A. C. and D. S. Farner. 1960. The annual cycle of thyroid activity in White-crowned sparrows of eastern Washington. *Condor*. 62:414-425
50. Wolfson, A. 1954. Weight and fat deposition in relation to spring migration in transient white-throated sparrows. *Auk*. 72:413-434.

WEST

DISCUSSION

JOHANSEN: I am very impressed with all the facts that are available on birds now. I think this surpasses what we know about mammals, particularly with regard to ecological factors involved in temperature regulation. I was particularly pleased to hear your doubts as to whether we really can consider the critical temperature as a fixed point, and also whether insulation is gradually mobilized during the period of active increase in metabolism. As I pointed out in my paper, I think this applies also to the more primitive mammals.

WEST: And I think also to the small mammals.

JOHANSEN: Definitely. I had another question, and that is, how does this ten-fold difference in electrical activity correspond with the actual metabolic difference between the two? Could you comment on that?

WEST: We do not have the metabolism of the rats worked out in calories. Also no simultaneous measurements of metabolism and shivering have been done at a series of temperatures for mammals.

JOHANSEN: I was wondering whether you could correspond metabolism with electrical activity.

WEST: I have done it for birds but not for mammals. In birds there is a linear relationship between electrical activity and metabolism. The slope varies with the size of the bird. So far we have plotted data for three species and the smallest, the common redpoll, increases its electrical activity much faster than it does its metabolism. The larger birds do not increase their shivering as fast and there is about a 45° slope for birds of about 100 grams.

HART: It is much higher for birds than it is for mammals.

BIRD ADAPTATIONS

HART: No, not ten times. For example, the pigeon has about the same weight as the rat, and it has about five times the electrical activity. We do not know enough about different species of birds, but this is the trend. It seems there is a much greater electrical activity in birds.

WEST: I think this will work out better when we put it on a power spectrum basis rather than a simple muscle potential.

HANNON: It would seem, if you had a good measure of shivering activity, you should be able to have a 45° relationship between metabolic change and shivering change or muscle activity change.

WEST: Yes, muscle is the source of total heat production and I believe that if the results are standardized on a body surface basis the lines would be close together.

HANNON: Because your peak microvolts went up considerably faster than your metabolism did.

HART: Yes, that went up about ten times.

HANNON: For 100% increase in metabolism, there is a considerably greater increase in peak microvolts as a measure of your shivering.

WEST: I agree, for the smaller species.

PROSSER: After all, what you are concerned with is the energy produced by the chemical reactions in the muscle. Might not a delicate vibration detector or something for measuring movement be as effective? Have you tried any of these spring gadgets?

IRVING: Ballistic cardiograph?

PROSSER: Yes, like a ballistic cardiograph.

WEST: We have not tried any, no.

ADAMS: I would suggest that there must be a constant difference in the relationship between the shivering index as you have it and the oxygen consumption, since you do have a straight line relationship. And if this is true, then perhaps we have a frequency recording artifact all the way along the scale, not just at one peak.

WEST: The frequency of shivering is very low at the higher temperatures and we do record that faithfully, because it only goes up to around 200 cycles per second or so, but our recent analysis shows that intense shivering goes as high as 700 c.p.s.

PROSSER: Of course you have to sacrifice the bird, but just as a check it might be useful to do phosphocreatine breakdown. I would like to ask one question about the fact that you find no difference in the slope or in the shivering response with the seasons, but do find that the winter birds can maintain their metabolism longer under cold stress. Now, this suggests that acclimatization may be an endocrine phenomenon. Have you any information about the state of the adrenal cortex?

WEST: Not about the adrenal cortex, but a little on the thyroid. But Wilson and Farner, and Oakesen and Lillie have found that the thyroids of permanent resident birds that were held in one spot increased in the winter time because the temperature fluctuated greatly, which corresponds to the permanent resident metabolic acclimatization. But birds studied on their wintering ground in California and on their summer ground in Alaska, showed no difference in thyroid, "because" they experienced a temperature fluctuation both summer and winter of 5°C , whereas those maintained in Washington had a temperature fluctuation of 20°C . This may be a tie-up there, although this is very tenuous, and there are results in thyroid activity going in the other direction for some species. I do not know anything about the adrenal.

IRVING: I look at migratory birds from the wrong end. I mean from the unconventional end of being on the arctic ground where the birds arrive after migration, instead of in the temperate places from which they are preparing to start. It has always been

BIRD ADAPTATIONS

interesting for me to see this migratory fat still preserved by birds at the time of their arrival on the nesting ground, and then diminishing markedly during the period of courtship of the male and somewhere along during the incubating period of the female. So I am not sure that it is strictly and seasonally a migratory fat, although it may be useful for the bird to pack his California fat up to Alaska. But certainly the moment when migratory fat is utilized is, like the fat of the bull fur seal, during the actual breeding period.

WEST: Are you speaking of shore birds primarily?

IRVING: It is pretty general among the birds arriving in arctic Alaska breeding grounds. There are some 40 species for which I have sufficient records to be indicative including all families and sizes.

WEST: Do you think possibly a sandpiper or plover who may fly non-stop over a great distance could retain a large proportion of his fat when he reaches the breeding ground?

IRVING: They do have considerable fat when they arrive so far as I can compare weights with those of similar birds when they were ready to depart from the wintering grounds. They may be a little less fat, but they are still very fat birds.

WEST: The question then arises how they get enough energy to fly that distance unless they stop enroute to keep augmenting their fat stores, which we know to be the case in passerines.

IRVING: I realize these are net results, but the situation of the observer can change one's point of view. You mentioned the energy requisite for reproduction. The other day I was looking at the eggs of Least Sandpipers, which, like all sandpipers, are quite large. We weighed these and the four eggs weighed 25 grams. They were laid on four successive days and the female bird which produced them weighed 21 grams; I suggest that you might start introduction of Least Sandpiper blood into white leghorns because the sandpiper equals her weight in egg production in four days, instead of the two months necessary for the good white leghorn to equal her weight of egg production.

WEST

FOLK: I have two points to make: one is, we are equally surprised to find a large quantity of fat in hibernating ground squirrels after 4 months of hibernation. Not all animals, but some are very conspicuously fat in spite of the fact that they awaken periodically. This matches Dr. Irving's observations on birds. The second question is a technical one. In measuring the oxygen consumption of the evening grosbeaks you described a 3-day run with a hood on the cage. Do you continue a photo-period during this period?

WEST: Yes.

FOLK: And what is the photo-period?

WEST: Ten hours of light. We use a lucite cover with a loose polyvinyl plastic cylinder taped to it that slides down over the cylindrical cage and is sealed to the sides of the cage with electrical tape. An outlet is provided at the top where air is pumped out into the oxygen analyzer. An inlet is provided at the base of the cage. These cages are identical with the cages we use for acclimation or for housing the birds, and so we just have to drop the hood over them. I think there is a lot to this psychological business. They do not have to adjust to a new cage.

IRVING: I have seen calculations on fat and tried to make some myself to indicate that a gram of fat will transport a 20 gram bird quite a long distance; the several grams that they have is adequate for quite a considerable extra expenditure of metabolic energy, but how about the requirement for water? I have not seen reference to any visible reserve for water.

WEST: You mean birds migrating over the ocean?

IRVING: Yes. I wonder how they hold out.

WEST: You do not think they get enough metabolic water?

IRVING: I do not know. Can you calculate the water requirements and relate them to stores?

WEST: I have not done so.

BIRD ADAPTATIONS

IRVING: Rough calculations which I have tried to make and which I do not trust suggest that water may be much more critical than the fat.

WEST: You are thinking, of course, of birds that are flying over the ocean.

IRVING: Yes.

WEST: And I am always thinking of sparrows that hop, skip, and jump 100 miles a flight and then come down.

IRVING: This flight is nothing to them; it takes an hour or two.

WEST: Yes, they do about 30 miles an hour, roughly. How long does it take for an Arctic Tern or Golden Plover to go its distance non-stop? Do they not go very fast?

IRVING: The travel of the plover from Alaska to Hawaii and from New Foundland or Nova Scotia to South America is a couple thousand miles non-stop.

WEST: How many hours, forty-eight hours?

IRVING: It is in the order of a couple of days rather than so many hours.

WEST: I think they could probably make it all right with respect to water requirements.

PROSSER: Are you sure they never put down?

IRVING: It has not been observed and it is inconceivable that they could derive any benefit from it except to sit out the time. They are not swimming birds. They could not feed there.

HART: Could they drink the sea water and excrete the salt?

MORRISON: I would like to return to the matter of the applicability of these simple relations between metabolism and ambient temperature, which was first raised by Dr. Johansen's talk. I do not think that we should speak as though this relation is discredited and not applicable in these animals. We must remember that these represent limits which any animal will follow more or less closely. They are limits of minimum metabolism and of minimum thermal conductance and as such are excellent descriptive terms. Now, the great deviation of your birds from the limiting curve is very interesting as representing a physiological inefficiency since this extra metabolism need not be expended if the bird were using the maximum potential of its insulation. It would be useful to describe the bird both in terms of its limiting conductance, and also in terms of its deviation from that limit. Perhaps this might be in terms of the temperature range over which it deviates and the ratio of the measured and the basal metabolism at the critical temperature.

WEST: I agree to that, but with these birds there is such great deviation we should not force our data to fit the classical theory, just because it is a classical theory.

JOHANSEN: Critical temperature as a term is only meaningful when we know that the core temperature stays constant up to this point.

MORRISON: I am not sure that the critical temperature has been strictly defined in terms of these refinements.

PROSSER: Why does a bird molt? It seems to me a most wasteful thing. What is the advantage of getting rid of an old set of feathers to grow a new set?

WEST: They wear out.

PROSSER: Are new feathers really better insulators?

WEST: They probably are. I do not know, but they wear out. From the behavioral standpoint, they have to grow their new colors again for the fall and spring. We know that the total weight changes,

BIRD ADAPTATIONS

but we do not see any evidence in any of our curves that there is any effective increased insulation.

HANNON: This goes on in most animals, does it not? We grow more skin continuously.

IRVING: If you look at the plumage of birds from tropic or arctic locations, you have a hard time convincing yourself by that examination that one is arctic and one is tropic. Among the jays you might think that there is a little thinner body plumage on the tropical than on the arctic form, but the quantity of feathers does not seem to vary very much with the climate where the specimen originated. Of course feathers are not for insulation alone; they serve an aerodynamic function in which the dimensions of a bird that would be affected by increasing its feathers would quite destroy its aerodynamic qualities, although a mammal can carry fur ten times as long if he does not trip over it.

PITELKA: Your question, Dr. Prosser, is aggravated by a circumstance which is not yet well documented in the literature, which is that some tropical species, if they are not breeding, are molting. Dr. Irving a moment ago mentioned tropical jays; I have some data shortly to be published for a 50-gram species of tropical jay. The breeding season is March through June or July and otherwise the population as a whole is molting, starting its molt in late May and continuing into February, so that in effect the birds are either breeding or molting. And when we get situations like this, contrasting with tree sparrows or longspurs which molt in a very short time, then the whole business of budgeting of energy and the advantage of the molt is so delicately adjusted as it is, becomes more interesting and intriguing.

I would like to comment on a couple of other things about plumage which are relevant to Dr. West's remarks about insulative problems and also relevant to something Dr. Irving said a moment ago. There is one kind of difference between high latitude and tropical birds which, to the best of my knowledge, has gone unnoticed in the literature, and which as you will see, must obviously bear a great deal on the capacities of birds that deal with low temperatures

WEST

and also bear a great deal on the rates at which they can or do adjust to lowering temperatures. We talk about feather tracts, and apteria, but I invite you to trap a Snow Bunting in late May and rip all its contour feathers off. In other words, rip the feathers off the pterylae, that is, the feather tracts. What will you have left? You will have a body which is covered with a dense down which covers the apteria.

I have prepared finches from high latitudes and low latitudes, and there is a striking trend. The lower latitude finches are genuinely naked on their apteria, but the high latitude ones which I have examined, the Golden Crowned Sparrow, the Lapland Longspur, and the Snow Bunting, are not. This must be a relevant consideration to those interspecific differences on Dr. West's graphs which seem puzzling.

Another little detail which is perhaps a little more esoteric is this: in larger passerines like the Steller's Jay, there is a highly modified, stiff, hair-like feather, which is distributed over the body. What is this for? I am not sure that I have an answer to what it is for, and I have not said anything about this in print because there is such a depressingly large European literature on plumage that I have not gone through it yet to see if somebody has said something on the matter. But these stiff, hair-like feathers, distributed over the body on a large passerine which has a very lax and dense plumage, could increase the efficiency of spacing of the plumage when the bird expands it and contracts it; and the presence or absence of these hair-like feathers must be another little detail that has to be plugged into these considerations of why Dr. West's curves deviate as they do.

WEST: What is the distribution of those? Are these filoplumes?

PIPELKA: Yes, filoplumes. They are regularly distributed among the contour feathers.

WEST: How about on the smaller birds, sparrows?

BIRD ADAPTATIONS

PITELKA: I do not think they are present. I am not sure about that. I have not looked for them, actually. If they are there at all, they are certainly not easily noticed.

HUDSON: I would like to add to Dr. Johansen's, Dr. Morrison's, and Dr. West's remarks with respect to the lower critical temperature. In our laboratory we have had a number of cases in which we have been unable to get nice extrapolations of the metabolic rate to the appropriate body temperature, and in some cases we get extrapolated body temperatures as high as 44°C and 45°C . At the same time, using the same techniques and animals from similar areas, we are also able to successfully extrapolate, so that we are reasonably certain that it is not our technique, but have the feeling that possibly there was some change in conductance going on even below the lower critical temperature.

PROSSER: May I ask just one more question about the computed insulation curve? If similar curves are constructed for mammals, what would be the shape and the value of the index that Dr. West presented?

HART: In lemmings, during activity there is a large variation, but during rest in mice at least, the variation of insulation with temperature was similar to the hypothetical insulation curve for birds except that it conforms more closely to the critical temperature. In other words, the curve becomes flat at higher temperatures. If body temperature is constant and the correlation between metabolism and temperature extrapolates to zero at a value higher than body temperature, then insulation would increase with fall in temperature in a manner comparable to that seen in birds.

HUDSON: And these are also animals which have, from general appearance, reasonably good coats, have metabolic rates that are approximately what you would expect from their body size, but also have lower critical temperatures that are extremely high, that is above 30°C . So that on the basis of general judgment you would expect the animal to have the capacity to continue his regulation by physical means through much lower temperatures than he does.

IRVING: It is so hard to figure on some of these things in examining the metabolism of the Brant in summer and winter. The Brant is a big bird weighing a kilogram and a half, and with feathers so thick that when you grasp hold of him you cannot feel through the underlying bird or meat, and yet its metabolic rate begins to increase at just about freezing temperature. It is a bird with the thickest insulating feather cover that you can find, and yet he does not use it for insulation. Of course the Brant, like the other water fowl, follow the open water throughout the year and perhaps they do not need any more insulation, but that does not give any physical explanation. In fact, the explanation is probably physiological rather than a matter of simple feather thickness.

MORRISON: As far as changing body temperature goes, of course this relation is related to difference between body temperature and ambient temperature.

IRVING: Are you not working in a limited range of animal size where the measurements are difficult? Perhaps life itself is difficult for animals of these very small dimensions and they have to resort to metabolic subterfuges which are legitimate for them but illegitimate from our point of view. They are difficult to examine because you are looking at the 10 to 100 gram or so size range. Perhaps some clarification would come if you went to larger birds; I think your only representative above 100 grams was the pigeon, was it not?

WEST: Yes, I was concerned with the small wild birds, most of the passerine group.

PROSSER: Are you saying that this temperature-metabolism curve rises continuously as you go to lower temperatures, and that you have no thermo-neutral zone or critical temperature for smaller birds, while in a larger bird there is a critical temperature?

WEST: Yes.

BIRD ADAPTATIONS

IRVING: I do not say that these deviations from what we expect to be the rule, or what we would like to hope would be a rule, are incorrect. I am sure they are correct, but they may represent the deviations of birds on account of size, as small mammals deviate.

RACIAL VARIATIONS IN HUMAN RESPONSE TO LOW TEMPERATURE

Frederick A. Milan

The investigations of racial variations in thermoregulation have been based on the premise that races of mankind inhabiting regions characterized by seasonal or diurnal periods of low temperature are biologically adapted* to life in these environments. It has been assumed that thermoregulation in a race living in regions of low temperature may function differently from that of a race in a warmer climate. These studies of racial variation in physiologic function are attempting to accomplish the task recommended for biologists by Prosser (1959). This task is to assess critically the functional adaptive features (including behavior) that can describe the unique fitness of a species to its environment.

According to the inferential evidence of archaeology and paleontology, Homo sapiens evolved in tropical Africa and Eurasia, and his original geographical distribution resembled that of the present day Old World non-human primates. Early hominids presumably lived in a thermally neutral environment. It has also been clearly shown by finds in Tanganyika that prehominids had already acquired tools and fire before Homo sapiens evolved as a species (Washburn, 1959).

It is obvious that man erects a cultural screen of dwellings, clothing, living techniques, and behavioral adjustments between himself and his environment. Except at high altitudes (as on the Bolivian altiplano, for example) where little can be done about low oxygen tension by preliterate peoples, man's cultural screen effectively ameliorates environmental stress and is an essential part of his external temperature regulation. This cultural carapace must be considered in enumerating human groups chronically exposed to low temperatures.

*A biological adaptation is "...an aspect of the organism that promotes its general welfare, or the welfare of the species to which it belongs in the environment it usually inhabits" (Simpson et al., 1957).

MILAN

Experimental data are available which describe some aspect of thermoregulation in peoples as various as Eskimos, Arctic Athapascans, South American Indians (the Alacaluf), Norwegian Lapps, Australian aborigines, African Bushmen, American Negroes, European Norwegians, and a host of North American White controls. In this paper these data will be reviewed and the results of my own experiment which was designed to further investigate thermoregulation and to compare tissue insulation in Anaktuvuk Eskimos, Athapascans, and Caucasian soldiers will be presented.

A HISTORICAL REVIEW AND LITERATURE SURVEY

The Eskimo

Possibly because of their geographical location, the earliest studies were undertaken on the Eskimos. The Eskimos are a genetically, linguistically, and culturally homogeneous population living along the coasts of Greenland, Northern North America, and a small area of Siberia. It is apparent that they have been in the Arctic for a considerable length of time. The Denbigh Flint Complex of Norton Sound, presently the oldest cultural assemblage on the Alaskan side of the Bering Strait, has been dated at between 2500 and 3000 B. C. Eskimo type cultures have succeeded one another in this area from about 500 B. C. to the present (Giddings, 1960). Material from the bottom layers of a midden at Nikolski, Umnak Island, in the Aleutians has been dated at about 3000 B. C. (Laughlin and Marsh, 1951).

A folk migration of expert arctic travelers, carriers of the Thule culture, wandered from the Bering Strait 6,000 miles to Greenland about 1,000 years ago and caused the present linguistic, racial, and cultural homogeneity over this vast area (Collins, 1954). The Thule people replaced the earlier arrivals, the Dorset people, who had been in the eastern Canadian Arctic and Greenland since about 675 B. C. (Larsen and Meldgaard, 1958). The first European-

HUMAN RACIAL RESPONSES

Eskimo contact occurred in 988 A. D. when Eric the Red encountered the Greenlanders.

The main characteristics of the climate of the high Arctic are year-round aridity, low temperatures and high winds with drifting snow in winter and cool temperatures and a high incidence of fog in summer. It has been clearly recognized by physiologists that the success of the Eskimo in exploiting his environment is due to the fact that he carries his private microclimate about with him. Nevertheless, it is difficult to understand how one could live in the Arctic and not suffer occasional cold exposure, and therefore many physiological investigations have been designed to elucidate the more subtle differences in thermoregulation.

Basal metabolism. August and Marie Krogh (1913) reported that the Greenland Eskimos were utilizing more than 300 gm of protein in their diets per day and later suggested to Hygaard (1941) that the elevated heat production (+13% of the DuBois Standard) of 22 Angmagssalik Eskimos of East Greenland may have been due to dietary factors. An elevated basal metabolic rate has been reported by almost all investigators of the Eskimo. Rodahl (1952), who has reviewed the early literature, measured surface areas, and measured the BMR's of 73 healthy Eskimos, concludes that apprehension and the high protein diet are the reasons for the high BMR. MacHattie et al. (1960), however, on the basis of the 24 hour metabolic studies of the night fuel energy fractions in Anaktuvuk Pass Eskimos, consider factors (unknown at present) other than the SDA of protein to be involved.

It is puzzling to many that the SDA of protein has such long lasting post prandial effects on Eskimo metabolism. Keeton et al. (1946), however, fed experimental diets high in either protein or carbohydrate to 12 male conscientious objectors for 5.5 months and reported an 18% to 19% increase in metabolism (6 hours after the last meal) due to the SDA of protein. And Hicks et al. (1934) reported the SDA of raw meat ingested by Australian aboriginals to be 80% after five hours.

Brown et al. (1953) measured BMR's in nine males and seven females at Southampton Island and reported them to be between 124% and 130% of normal. They described their subjects as clinically hypermetabolic but not hyperthyroid in the sense of thyrotoxic. The suggestions of others that the elevated BMR might be due to anemia, polycythemia, racial characteristics, unidentified disease, or the high protein diet were discussed. They have concluded that the high metabolic rate was not entirely the result of a high protein diet, but that the diet is merely another manifestation of the effects of the environment and the food available.

Thyroid metabolism. Gottschalk et al. (1952) measured the protein bound iodine in seven U. S. soldiers attending an arctic indoctrination course at Fort Churchill, seven male Eskimos from Southampton Island, and seven Eskimos from Chesterfield Inlet in winter. There was no change in the soldiers' basal metabolic rate or PBI due to their arctic sojourn. The Eskimos had significantly higher values in PBI (4.2 to 9.0 microgram percent) than euthyroid patients in U. S. hospitals.

Rodahl et al. (1956, 1957) administered tracer doses of I^{131} to 84 Alaskan coastal and inland Eskimos, 17 Athapascan Indians of Ft. Yukon and Arctic Village, and 19 white controls to assess the role of thyroid in man during cold exposure. Except for the inland natives, there was no significant difference in thyroid uptake or urinary elimination of I^{131} or in PBI 131 and no seasonal difference in PBI. There was no significant difference between natives and whites in PBI. The Anaktuvuk Eskimos and the Arctic Village Indians had high and rapid uptakes of I^{131} which were related to the low iodine in their diets and to the high incidence of endemic goiter. A reduction in the rate of uptake of I^{131} occurred following supplementation daily for 3 months of 0.6 mg potassium iodide.

Blood volumes. Brown et al. (1953) measured blood volumes by dilution of Evans Blue dye and hematocrits in 22 male Eskimos at Southampton Island. They reported blood volumes to be 124% to 142%

HUMAN RACIAL RESPONSES

above normal (normal is 100%). The increase was noted in both the plasma and in the total red blood cell volume.

Response to extremity cooling. Pecora (1948) studied the "pressor response" in 23 male Eskimos of Nome and Fairbanks using a sphygmomanometer and compared the results with those of similar experiments conducted on 44 Caucasian soldier controls. An arm was immersed in unstirred water with a temperature of 4° C to 5° C. The Eskimo group had a higher basal blood pressure, but the increase due to the cold immersion was less than in the control group. In addition, the Eskimos reported less subjective pain.

Brown et al. (1952), by venous occlusion plethysmography, measured hand blood flow in 22 male Southampton Island Eskimos and 37 Queens University medical students in room air and in water baths ranging between 5° C and 45° C. The hand blood flow of the Eskimos was nearly twice as great as that of the Caucasians in room air of 20° C. Values were: Eskimos, 8.6 cc/100 cc tissue/min; controls, 4.7 cc/100 cc tissue/min. The Eskimo hand flow was greater at any given water bath temperature.

Brown et al. (1953), by venous occlusion plethysmography, determined forearm blood flow and measured the temperatures of forearm skin, subcutaneous tissue, muscle, and rectums of 29 male Southampton Island Eskimos who were not all racially pure and 37 male Kingston Ontario medical students. In a 45° C water bath, the blood flow was similar in both groups. Below 45° C the Eskimo group had a greater blood flow. In water baths below 38° C the Eskimo forearm muscle temperature was lower as a result of a greater venous return and consequent cooling of arterial blood. In the 5° C bath, the Eskimo forearm flow was 3.8 cc/100 cc tissue/min in contrast to 1.5 cc/100 cc tissue/min in the medical students.

Page et al. (1953) investigated hand blood flow, subcutaneous temperatures, muscle temperatures, and rectal temperatures in Southampton Island Eskimos and a control group of medical students during heating and cooling of the legs in water baths. During heating at 42.5° C forearm muscle temperature and blood flow was

greater in the control group. During cooling of the legs at 10°C the Eskimos showed little change in blood flow in contrast to the controls who showed a pronounced fall.

Elsner (1960) measured limb blood flow in six Anaktuvuk Eskimo males and athletic and non-athletic Caucasians. Limb blood flow was somewhat elevated at rest in the Eskimos.

Meehan (1955) measured the temperature at the base of the nail of the right index fingers of hands immersed for 30 minutes in stirred ice water in 52 Alaskan natives (14 from Barter Island, 24 from Fort Yukon, and 14 from Gambell), 38 American Negroes, and 168 Caucasians. During the last 25 minutes, the Alaskan natives maintained the highest mean finger temperatures. Only 5% of the Alaskan natives, in contrast to 21% of the Caucasians and 62% of the Negroes, had mean finger temperatures of 0°C during the last 25 minutes.

Pain sensation. Meehan et al. (1954) investigated the "warm" pain threshold in 26 Athapascan Indians, 37 Anaktuvuk Pass Eskimos, and 28 white controls. A 3-second thermal stimulation on the back of the hand was used. The threshold was about 43.1°C to 43.7°C , and there was no significant difference between the groups.

Differential sweat rates. Rodahl et al. (1957) investigated the comparative sweat rates of six male Anaktuvuk Pass Eskimos and five male Caucasian controls exposed nude for 3 hours to several ambient temperatures during exercise (15 minutes at 3.5 mph on an 8.6% grade) and during a 3 hour walk wearing standard clothing at -23°C . They found that at all ambient temperatures the resting metabolic rate for the Eskimos exceeded that of the Caucasian group by over 30%. The average skin temperature of the Eskimo tended to be higher at all environmental temperatures below 35°C . The Eskimo skin, particularly of the forehead and back, had a greater concentration of active sweat glands at 33°C environmental temperature. During the treadmill exercise the group differences were not significant, although the Eskimo group had to dissipate 21% more heat to maintain the same body temperature. According to nude

HUMAN RACIAL RESPONSES

weight loss, the Eskimos' sweat rate was twice as great during the 3 hour walk at -23°C . The elevated metabolism of the Eskimo required that they increase total body heat loss to maintain thermal equilibrium, and the sweating mechanism accounted for the dissipation of 91% of the excess heat. Respiratory heat loss (Eskimo $5.1\text{ Cal/m}^2/\text{hr}$; White $3.4\text{ Cal/m}^2/\text{hr}$) was constantly greater in the Eskimos because of a higher minute volume.

Kawahata et al. (1961) counted active sweat glands during maximal sweating at an ambient temperature of about 41°C in Caucasians, Negroes, and eight female and two male Eskimos of Anaktuvuk Pass, Alaska. The rank order in total number of sweat glands beginning with the lowest number was Caucasian females, Caucasian males, Eskimo females, Negro males, Eskimo males. The rank order in number of sweat glands per cm^2 of body surface area was Caucasian females, Eskimo females, Caucasian males, Eskimo males, Negro males.

Response to whole body cooling. Adams et al. (1958) exposed 6 Anaktuvuk Eskimo males, seven American Negroes and seven Caucasian soldier controls nude for 120 minutes to an air temperature of 17°C . The Eskimos had a higher metabolic rate in the control period (Eskimo 50, White 40, Negro $38\text{ Cal/m}^2/\text{hr}$). The average rise in metabolism due to shivering was similar in the Eskimos and soldier controls ($22\text{ Cal/m}^2/\text{hr}$). The Eskimo group had higher core and shell temperatures during cooling and shivered, as did white controls, when the average skin temperature reached 29.5°C .

Tissue conductance. Covino (1960, 1961) studied thermal regulation in five Pt. Barrow Eskimos and five controls (including one American Negro) immersed in a bath calorimeter at 35°C and 33°C . The Eskimos produced more heat and lost more body heat during the immersion periods and their rectal temperatures fell to lower levels. There was no difference in digital blood flow. The greater tissue conductance was related to the significantly smaller percentage of body fat in these Eskimos.

MILAN

Adipose tissue. Covino (1960, 1961) and Elsner (1960) report that the body fat content of all Eskimos is characteristically low.

Eskimo summary. Possibly owing to dietary factors (Rodahl, 1952), Eskimos have a 20% to 30% higher basal metabolism than Caucasians when S. A. (Brown et al., 1953; MacHattie et al., 1960) or lean body mass (Covino, 1960) is used as a reference standard; and this difference is maintained during shivering (Adams et al., 1958) and exercise (Rodahl et al., 1957). At high ambient temperatures or during a hard walk in the cold, sweating accounts for most of the dissipation of the excess heat (Rodahl et al., 1957). In addition, a higher minute volume results in a greater respiratory heat loss (Rodahl et al., 1957). During a whole body cold stress, the "critical temperature," which causes a rise in metabolism by shivering, is the same in Eskimos and Caucasians (Adams et al., 1958). When either legs or hands are cooled in water, blood flow is greater in the hands and forearms of Eskimos (Brown et al., 1952; Brown et al., 1953; Page et al., 1953; Meehan, 1955). The threshold for "heat" pain is the same (Meehan, 1954) but there are suggestions of a difference for "cold" pain. Tissue conductance in cold water immersions is greater because of a significantly smaller percentage of body fat and a higher heat production (Covino, 1960, 1961; Elsner, 1960). The Eskimo has a higher metabolic heat production which requires a greater potency of heat dissipation mechanisms. According to Hardy (1961) it is body temperature which is regulated by the hypothalamus, not the energy flux through the organism.

Athapascan Indians

The antiquity of the northern Athapascan tribes is presently unknown. The exigencies of a nomadic existence in a subarctic environment imposed certain arbitrary population controls; few permanent camps were established, and artifactual remains are sparse. They presently inhabit interior Alaska and Canada, where a continental type climate results in seasonal extremes in temperature. According to Sapir (1936), Newman (1954), and Kraus et al.

HUMAN RACIAL RESPONSES

(1956) language affinities between the Apaches and the Northern Athapascans indicate that the former migrated southward 400 to 600 years ago.

Response to whole body cooling. Meehan (1955) measured metabolic rates, and surface and rectal temperatures of nine male Fort Yukon natives and Caucasian controls clad in a light underwear suit and exposed for 90 minutes to an air temperature of 6°C to 7°C . Initial resting metabolic rates and respiratory quotients were close to basal values and were the same in both groups. In the cold room, the natives shivered more and had a significantly higher metabolic rate increase ($142\pm 22\%$) after 90 minutes than did the Caucasian controls ($77\pm 11\%$). The hands and feet of the natives were significantly warmer and the Caucasians incurred a greater total heat debt.

Irving et al. (1960) measured the sleeping metabolism, rectal temperatures, and skin temperatures of eleven male Old Crow Indians and seven Caucasian controls. These parameters were measured during 7 hours of warm sleep and 7 hours at 0°C with about 1 clo insulation. Initially, the Indian basal metabolism was approximately 14% higher than Benedicts' standards. By using "lean weight" as a reference, the two groups did not differ in metabolism. During the cold exposure the average elevation of metabolism in the Indian subjects was 29% and in the Caucasians 32%. During the warm nights the Indians and controls were awake 12% and 13% of the time respectively. During the cold nights the Indians were awake 49% and the Caucasians 69% of the time. During both warm and cold nights the Indians lost more heat from body storage. However, the skin temperatures of the Indians and Caucasians did not differ significantly, and no evidence was found of adaptation in metabolic rate of thermal reactions.

Elsner et al. (1960), in order to investigate seasonal differences in the Old Crow population, restudied eight male Indians in the spring. Metabolism, skin temperatures, and rectal temperatures were measured during sleep at 0°C to 3°C with 1 clo insulation. Basal oxygen consumption of four natives was approximately 10%

above DuBois standards. Metabolism increased 30% during the night; and skin and rectal temperatures declined as in the previous study. It was concluded that meager evidence for general metabolic and thermal adaptation was found by methods which revealed important differences in naked Australians and warmly dressed Lapps.

Response of extremities to cooling. Elsner et al. (1960) studied the transfer of heat via the circulation of blood to the hands of Old Crow Indian males. In the first experiment nine Indians and eight Caucasian controls immersed their right hands in 5^o C water for 30 minutes after a control period of 30 minutes in 30^o C water. These experiments were done with the subjects clothed in a warm room and unclothed in a warm room. The Indian hands transferred a significantly greater amount of heat to the water in both the warm and cold environments. In a second experiment, six Indians and five controls immersed the right hands in ice water. The Indian group had a more rapid rewarming and suffered less pain.

Meehan (1955), quoted earlier, reported warmer finger temperatures in ice water in Fort Yukon natives as compared to those of Caucasian controls.

Physical fitness. Anderson et al. (1960) investigated the physical fitness of eleven male Indians from Old Crow. Respiratory gas exchange and heart rate during steady state exercise were measured. The response of extra ventilation to a standard exercise load was also determined. The results showed that the Indians occupied an intermediate position between young sedentary Norwegians and Norwegian athletes in their fitness for work.

Athapascan Indian summary. Basal metabolic rates are the same in Athapascans as in Caucasians when compared to "lean weight" (Irving et al., 1960), but 14% higher than Benedict's standard, and 10% above DuBois standard values (Elsner et al., 1960).

Indians showed no difference in metabolic and thermal reactions when compared to Caucasian controls that were exposed to low

HUMAN RACIAL RESPONSES

temperatures during sleep in the fall (Irving et al., 1960) and the spring (Elsner et al., 1960).

Indians, even when in negative heat balance, have warmer hands in cold water than Caucasian controls (Elsner et al., 1960) and warmer fingers in ice water (Meehan, 1955).

Physically the Indians are lean (Irving et al., 1960) and occupy an intermediate position between young sedentary Norwegians and Norwegian Olympic athletes in their fitness for work (Anderson et al., 1960).

The Lapps

Lapland, which has no political existence, consists of the forested highlands of northern Sweden, tundra-covered areas of northern Finland, Norway's coastal province of Troms and Finnmark, and much of the Russian Kola Peninsula. The Lapps presently number about 35,000. They have national allegiance to the country where they are domiciled and share this country, with a larger population of Finns, Norwegians, Swedes, and Russians with whom they have been interbreeding for centuries. Historical accounts seem to indicate that the Lapps were originally hunters who in about 1500 A. D. became reindeer domesticators, having learned this art from the Samoyedic peoples to the east. According to a number of blood surveys, the Lapps have apparently reached their present genetical constitution through long isolation as a relatively small population. Norwegian Lapps have in recent centuries received a larger genetical contribution from the outside than have the Swedish Lapps.

Russian Lapland, Finnish Lapland, and the part of Swedish Lapland situated above the Arctic Circle enjoy about the same temperatures as the southern half of the Labrador peninsula because of the ameliorating effect of the warm water of the Gulf Stream upon the climate (Milan, 1960, from published sources).

The information on the physiology of the Lapps is restricted to that obtained from studies of reindeer nomads and villagers from Kautokeino in northern Norway.

MILAN

Critical temperature. Scholander et al. (1957) determined the "critical temperature," i. e. the lowest temperature at which a resting metabolic rate maintained a constant body temperature, in nine male migratory Lapps from Kautokeino and three male Norwegian controls. The nude subjects bicycle on an ergometer wheel in a temperature regulated room. Rectal temperatures and oxygen consumption were monitored. The intersect of resting values of oxygen consumption and values in the cold occurred at approximately 27°C , and this was taken as the critical temperature. The subjects perceived a fall in rectal temperature as small as 0.2°C . Critical temperatures were the same in both groups.

By measuring skin temperature under the clothing of Lapps out-of-doors, it was determined that they live within a warm microclimate.

Response to whole body cooling. Lange Andersen et al. (1960) measured skin and rectal temperatures and metabolism in 14 male Lapps from Kautokeino and five male Norwegian controls during 8 hour exposure to 0°C while sleeping nude with about 1 clo insulation. The Lappish subjects consisted of five settled villagers and nine reindeer nomads. During the cold exposure, most of the reindeer nomads slept well with no obvious shivering. The controls slept poorly and suffered from surface cooling, especially in the legs and feet. The nomads and controls had similar skin temperatures, but the nomads lost more heat from the body core because of a lower metabolic heat production. The Lapp villagers were intermediate between the controls and nomads in their responses.

Response to extremity cooling. Krog et al. (1960) measured hand blood flow in a venous occlusion plethysmograph at various temperatures and hand heat loss and finger temperatures in 0°C stirred ice water. The subjects were 13 male Kautokeino Lapps, 10-12 Lofoten Island fishermen, 6-11 Gothenburg medical students, and 4 authors. Maximum hand blood flow at 10°C was similar in all subjects. Hand blood flow at 10°C and 20°C was the same in

HUMAN RACIAL RESPONSES

all subjects. The blood flow values reported in this study are considerably higher than those reported by Brown et al. (1952); these authors suggest that Brown kept his subjects cooler, and their hand flows were influenced by vasoconstrictor fiber activity. During immersion in 0° C water the temperatures of the cold habituated subjects (Lapps and fishermen) were similar to those of the controls. There was, however, an earlier onset of vasodilation in the Lapps and fishermen. Although the cold habituated subjects experienced less pain and discomfort, two Lapps and three fishermen fainted during the experiment. The results of the study did not support the hypothesis that cold habituated individuals possess a purely local vascular adaptation resulting in a greater blood flow through the hands.

Lapp summary. Kautokeino Lapps, when compared with Norwegian controls, slept well with no obvious shivering during a night exposed to an air temperature of 0° C and lost more heat from the core because of a lower metabolic heat production (Lange Andersen et al., 1960). Paradoxically, the critical temperature is the same for Lapps and Norwegian controls (Scholander et al., 1957). Hand blood flows at various temperatures and finger temperatures in 0° C water are the same for cold habituated nomadic Lapps, Lofoten Island fishermen, and controls, but the former two groups vasodilated earlier and reported less pain when vasoconstricted.

The Indians of Southern Chile

The aboriginal inhabitants of the islands in and around the Straits of Magellan in southern Chile and Argentina became famous for their cold hardiness through the writings of Charles Darwin, who visited this region in the H. M. S. Beagle. The Fuegian tribes consisted of the Chono, Haush, Ona, Vaghan, and Alacaluf. Only the physiology of the Alacalufs has been investigated.

The Alacalufs formerly inhabited the islands from the Gulf of Penas as far south as the northwest part of Isla Grande on Tierra del Fuego. This habitat is an isolated and densely vegetated region

MILAN

with 120 inches of precipitation, which falls as snow in winter. It has been estimated that the Alacalufs numbered between 3500 and 4000 in 1850. Presently there are about 50 Alacalufs who are settled on Wellington Island (Bird, 1946; Cooper, 1946).

Response to whole body exposure. Hammel et al. (1960) studied nine male Alacalufs exposed for 8 hours during the night to an air temperature of 2°C to 4°C and six male Alacalufs during sleep while comfortably warm. Oxygen consumption and skin and rectal temperatures were measured. No controls were used. At the beginning of the night the metabolic rate was about 60% above the basal values for a standard white European of the same weight, height, and age. In similar circumstances a white would be no more than 20% above basal values (Hammel et al., 1959). The average metabolism during the cold nights was indistinguishable from that during the warm nights, except for occasional bursts of shivering, and metabolism gradually decreased over the 8 hour period. The Alacalufs resembled the Indians of Old Crow in their metabolic responses, which were nearly twice as great as those measured in the Australian aborigines during a similar exposure. Rectal temperatures were about the same as those measured in European controls, while skin temperatures were about 1°C lower. The feet were about 2°C to 3°C warmer. Measurements of tissue conductance in the Alacalufs showed complete vasodilation in these subjects when sleeping warm. During the cold nights, tissue conductance was halved, but it was still 30% higher than in the Australian aborigines.

Responses to extremity cooling. Elsner in Hammelet al. (1960) measured the heat output of the feet and hands of Alacaluf Indians and three white controls in cold water. The hands and feet, after an initial immersion in 30°C water, were placed in 5°C and 10°C water, respectively. The range of heat output in these subjects overlapped that of white controls. Whereas the Alacaluf men and women reported no pain, the controls experienced intense pain in the feet during the immersion.

HUMAN RACIAL RESPONSES

Alacaluf summary. The Alacalufs studied in the field have an elevated basal metabolism, and during an 8 hour moderate cold exposure their metabolism is virtually indistinguishable from that measured while warm (Hammel et al., 1960). During cooling of the feet and hands, heat loss was similar to that of white controls but pain sensation, reported as intense in the controls, was absent.

The Australian Aborigines

The land connection between Australia and the mainland of Asia was submerged during the late Pleistocene. Australia then became a refuge area for archaic forms of plants, animals, and men. It has been estimated that the continent has been inhabited for about 15,000 to 20,000 years, and its human population has been described as tri-hybrid in origin, representing an amalgamation of archaic Caucasoids, Veddooids, and Australoids (Birdsell, 1950). This human population lived in virtual isolation until the first European settlement was established in Botany Bay in 1787. At the time of first European contact, the aborigines numbered about 250,000 in some 500 tribes, and they were naked (Elkin, 1954). In 1956 there were an estimated 60,000 aborigines in the population at large (Smythe et al., 1956).

Winter night temperatures in Central Australia fall to freezing or below, and the night sky radiation temperature is about 20°C lower. The aborigines who formerly slept naked on the ground between small fires were chronically exposed to cold.

Sir Stanton Hicks et al., (1931, 1933, 1934, 1938a, 1938b) and Goldby et al. (1938) initiated the pioneer studies of temperature regulation in the aborigines. Morrison (1957), while studying marsupials in Central Australia, measured aboriginal body temperatures. Scholander et al. (1958) and Hammel et al. (1959) have used more precise methods in extending and confirming the early data.

Observations during sleep in the natural state. Hicks et al. (1934) measured oxygen consumption and skin temperatures in sleeping male natives in Central Australia. They found that the metabolism of the natives was not elevated by the cold of early morning

MILAN

and that skin temperatures were low. They postulated a more effective vasomotor control than that of civilized individuals. After the ingestion of raw meat, the SDA of protein resulted in an 80% rise in metabolism after 5 hours. The RQ was measured as 0.7 in fasting subjects and moved toward unity after a meal.

Morrison (1957) used a Stoll-Hardy radiometer to measure skin temperatures in sleeping aborigines at Haast's Bluff in Central Australia. He concluded that the aborigines had a lower sensitivity to cold, which allowed them to sleep despite low body temperatures.

Scholander et al. (1958) studied the Pitjandjara tribe which inhabits the deserts of Central Australia. Two natives and two European controls slept naked "proper bush style," lying on the ground between two fires in winter. Neither Australians nor Europeans elevated their oxygen consumption, although the Europeans were uncomfortable and did not sleep well. The natives stoked their fires three to ten times while the Europeans stoked eleven to fourteen times. The natives tolerated a lower average skin temperature.

In a second experiment four Europeans and six natives slept naked in a bag of 1.9 clo insulation on a canvas cot under a thin radiation shield. Night temperatures were between 5° C and 0° C. The metabolism of the natives fell below basal values during the night, whereas the Europeans elevated their metabolism by bursts of shivering. The natives slept, while the European controls were kept awake by cold feet, although the natives had lower skin temperatures. It was concluded that the natives had adapted both their technology and physiology to withstand chronic cold exposure.

Hammel et al. (1959) returned to study the Central Australian natives in summer to see if the differences reported by Scholander et al. (1958) were seasonal. In addition, natives from the tropical north coast with a history of little cold exposure were studied. Eight male Pitjandjara, nine male tropical natives, and seven male European controls were exposed during sleep in a 1.7 clo bag in a refrigerated meat van for 8 hours at 5° C. The metabolism of the Pitjandjaras was lower than that of the European controls. The tropical natives were intermediate in metabolic response. The Pitjandjaras

HUMAN RACIAL RESPONSES

allowed greater cooling of the core and shell, their thermal conductance was significantly less, and their average skin temperatures were considerably lower. The low tissue conductance in the tropical natives resulted in skin temperatures which were intermediate between those of the Europeans and Pitjandjaras. The rectal temperatures were the same in the tropical natives and European controls. It was concluded that the Australian aboriginals had an inborn ability to tolerate greater body cooling without recourse to metabolic compensation and that this tolerance could be increased by prolonged exposure to cold.

Australian summary. Australian aborigines lying naked on the ground find low skin and rectal temperatures compatible with sleep (Hicks et al., 1934 and Morrison, 1957). Central Australian aborigines, when contrasted with European controls in a moderately cold sleeping environment, do not elevate their heat production despite low skin and rectal temperatures either in winter (Scholander et al., 1958) or summer (Hammel et al., 1959).

The American Negroes

American Negroes were transported as slaves from the old empires of Ghana, Melle, and Songhay in West Africa. The Negro-American population is by no means pure, and it is considered a race in the process of formation by several recent authors (Coon et al., 1950).

Responses to whole body cooling. Rennie et al. (1957) exposed eight male Caucasian soldiers and eight male American Negro soldiers for 90 minutes to -12°C in summer and winter. Subjects were clothed except for hands and fingers. The Caucasians had a higher heat production, and the increase in metabolism was delayed in the Negroes. After 70 minutes the Negro rectal temperature was significantly lower. Although the average skin temperature was the same, the Negro hands and feet were colder.

Adams et al. (1958) contrasted the metabolic and thermal responses of six male Eskimos, seven male Negro soldiers, and seven male Caucasian soldier controls exposed nude for 120 minutes to 17°C . While the Eskimos and Caucasians shivered at a mean skin temperature of 29.5°C , the Negroes did not shiver until their skin temperatures reached 28°C . Skin temperatures were the same in the Negro and control groups, but the metabolic response was greater in the latter.

Iampietro et al. (1959) matched 16 male American Negro soldiers with 17 male Caucasian soldiers for percentage fat, height, weight, etc. and exposed them nude for 2 hours to 10°C . Metabolic responses were the same. Although the difference between groups in average skin temperatures approached significance after 100 minutes (Negroes were 0.8°C lower), other temperatures were the same.

Response to extremity cooling. Meehan (1955) measured temperatures of index fingers immersed for 30 minutes in stirred ice water in 52 Alaska natives, 38 American Negroes, and 168 Caucasians and reported that Negroes maintained the lowest temperatures. Iampietro et al. (1959) measured temperatures of fingers in ice water in 16 male Negro soldiers and 17 male Caucasian soldiers. The white subjects had higher finger temperatures, and the "hurting" reaction was more pronounced.

Negro summary. The metabolic and thermal responses of American Negroes were reported to be different from those of white controls during a standardized cold stress of -12°C while clothed (Rennie et al., 1957) and 17°C while nude (Adams et al., 1958) but the same when nude at 10°C (Iampietro et al., 1959). The fingers of Negroes immersed in ice water are cooler than those of white controls (Meehan, 1955; Iampietro et al., 1959).

The Bushmen

Presently the Bushmen number approximately 55,000. They

HUMAN RACIAL RESPONSES

occupy a small fraction of their former territory and are found in South West Africa, Bechuanaland Protectorate, Angola, Rhodesia, and the Republic of South Africa. They are hunters and gatherers, lighter in color than their Bantu neighbors, and speak a Click language. In physical appearance they are short of stature (4 feet 9 inches to 5 feet 4 inches) and have a number of anatomical infantile features (Tobias, 1961).

The Bushmen were formerly distributed over much of southwest Africa but are presently confined to the high plateau of the Kalahari Desert at altitudes between 3000 and 5000 feet. Here the winter night climate is sufficiently cold to be stressful for a habitually naked people.

Response to whole body cooling. Wyndham et al. (1958) measured the skin and oral temperatures of two male Bushmen and two white South Africans sitting nude for two and one half hours. Ambient temperatures ranged between 10°C and 15°C . The oral temperatures of the Bushmen were lower. The skin temperature of one bushmen sleeping naked under his cloak next to a fire was measured for 8 hours. Ambient temperatures ranged between 12°C and 13°C . Air temperatures under the cloak were about 26°C , and temperatures on the trunk were about 35°C . It was concluded that the Bushmen have made an intellectual rather than a physiological adaptation to diurnal temperature changes.

Ward et al. (1960) measured the metabolism and skin and rectal temperatures in eight male Bushmen and five male European controls exposed naked to the Kalahari Desert night environment. Night temperatures ranged between 22°C and 2.7°C . A radiation shield was interposed between the subjects and the night sky. A thermocouple on a plastic holder manipulated by an observer was utilized to obtain skin temperatures. Face masks and a Douglas Bag were used to sample metabolism intermittently. The metabolic response in the Bushmen was higher than in the controls, but the percentage increase related to skin temperature was the same for the controls, Bushmen, and Norwegians (Ward et al., 1960). Rectal temperatures were similar. The Bushmen's skin temperatures were lower because

of less body fat. It was concluded that the Bushmen had not adjusted physiologically to the climate, but that they created a local climate around them, using the meager available materials.

Bushmen summary. While sleeping on the desert in his native environment, the Bushman utilizes an artificial microclimate to avoid cold exposure. Limited tests of skin and oral temperature decline in response to cold stress revealed no difference between Bushmen and controls (Wyndham et al., 1960). Bushmen subjected to moderate cold stress while sleeping nude for short periods have similar metabolic and thermal responses to those of controls (Ward et al., 1960).

ARTIFICIAL ACCLIMATIZATION OF MAN TO COLD

The results of experiments undertaken to artificially acclimatize man to cold or to study the effects of chronic cold exposure upon soldiers or arctic and antarctic sojourners, which complement the findings of cold adaptation in chronically cold exposed natives, will be briefly reviewed. Extensive and recent reviews of the literature on the effects of cold on man are those of Burton et al. (1955), Carlson (1954), Carlson et al. (1959) and Hardy (1960).

Scholander et al. (1958) exposed eight inadequately clad male Norwegian students to low ambient temperatures in the mountains of Norway for six weeks in September and October. Metabolism and skin and rectal temperatures were measured at night while the subjects slept with 2 clo of insulation at an air temperature of 3⁰ C. Their responses to the cold stress while sleeping were contrasted with those of 12 male controls. The acclimatized men had higher skin temperatures, especially in the feet, and they were able to sleep. They shivered in their sleep, whereas the controls did not sleep at all. A slight but transient elevation of basal metabolic rates and a

HUMAN RACIAL RESPONSES

2° C to 3° C lowering of the critical temperature occurred in the acclimatized.

Le Blanc (1956) found a significantly decreased oxygen consumption in cold acclimatized soldiers as compared with that of nonacclimatized controls when both were exposed to a series of standard acute cold stresses. He suggested that acclimatization is associated with a lowering of the body thermostat to more economical levels.

Milan et al. (1961) studied antarctic sojourners who spent a year at Little America V. The metabolic rates and the thermal responses of eight subjects (who served as their own controls), exposed nude to 17° C air temperature were measured over the year. Mean body and average skin and foot temperatures increased significantly over the year, while there was a decrease in heat production to meet the same thermal demands since shivering diminished.

Davis et al. (1961) exposed six male white subjects nude to 13.5° C air temperature in a cold room 8 hours each day for 31 days (except Sunday) in September and October. At the end of this period, metabolism remained between 35% and 75% above basal values, but shivering decreased. Skin temperatures were unchanged.

In a similar experiment, Davis et al. (1961) exposed ten male white subjects to 11.8° C for 31 days in March. At the end of this period, rectal temperatures had decreased (37.2° C to 36.7° C), skin temperatures were unchanged, and although metabolism was unchanged, shivering decreased. These authors suggest that these are indications of non-shivering thermogenesis.

Adams et al. (1958) and Heberling et al. (1961) have demonstrated that elevated skin temperature during cold stress may be a result of an increase in physical fitness.

Trends

Although it is difficult at first glance to generalize about these experiments investigating acclimatization and adaptation, there are certain trends which are apparent:

MILAN

- (1) An increased ability to draw upon body heat stores.
- (2) Vascular changes in the hands and feet in order to maintain warmer extremities.
- (3) A diminution of shivering, a moderate cold stress possibly related to what Elsner (1960) has termed "habituation."
- (4) A transient elevation of the BMR, resulting from an ability to shiver while sleeping.

Native peoples investigated are either naked or thinly clad exposed to moderate cold--the Australians, Bushmen, and Alacalufs, or heavily clothed exposed to extreme cold--Lapps, Eskimos, and Arctic Athapascans.

These cold adapted peoples show:

- (1) A form of insulative cooling with a decreased tissue conductance.
- (2) A metabolic sparing with the ability to draw upon body heat stores.
- (3) An elevated basal metabolic rate.
- (4) A decreased perception of cold sensation.
- (5) An increased peripheral blood flow.

This then brings us to a recent study done in collaboration with Drs. Hannon and Evonuk.

HUMAN RACIAL RESPONSES
A COMPARATIVE STUDY OF THERMOREGULATION
IN ESKIMOS, INDIANS, AND U. S. SOLDIERS

Subjects

The subjects for these experiments were six American white soldiers, six Alaskan Eskimos, and six Athapascan Indians. Their physical characteristics are presented in Table I.

Cold Exposure

The soldiers had been in Alaska less than ten days, had arrived from training camps in the southern states and, except subject 1, were all born in the Southern U. S. Their previous cold exposure was very negligible.

The Eskimos came from the isolated village of Anaktuvuk Pass in the Brooks Range and earned their livelihood by hunting and trapping land animals. They pursue a relatively vigorous existence in a cold climate.

The Indians came from the village of Tetlin, Alaska, on the Upper Tanana River. This is a region of climatic extremes and the lowest winter temperature in North America has been reported from this general area. Aboriginally these people were nomadic hunters; presently they are engaged in trapping and wood cutting, receive governmental subsidies, and are not as active in the cold as formerly.

Methods

These experiments were conducted in November, December, and January. Four and five days after they had arrived at the laboratory and had been subsisting on a hospitalic diet, duplicate measurements of basal metabolic rates were made on the Eskimos and

MILAN

Subj	Age	Wt. kg	Ht. cm	S.A. m ²	Total Skinfold mm	% Adiposity	% Fat	Lean Body Wt. kg
<u>Soldiers</u>								
G.	24	65.8	177.8	1.82	58	23	14	50.7
K.	24	75.4	179.0	1.93	51	22	14	58.9
F.	21	77.3	183.0	2.00	49	22	14	60.3
R.	24	64.3	176.0	1.79	43	21	13	50.8
L.	24	78.4	178.8	1.96	50	22	14	61.2
B.	26	93.2	180.4	2.15	172	41	25	55.0
<u>Indians</u>								
A.	18	52.7	169.4	1.59	17	13	8	45.9
M.	19	55.1	168.3	1.62	37	19	12	44.7
J.	19	65.0	174.0	1.79	24	15	9	55.3
T.	19	70.0	171.4	1.82	35	19	12	56.8
D.	36	70.9	175.2	1.86	53	23	14	54.6
J.	28	79.3	171.5	1.92	90	30	19	55.5
<u>Eskimos</u>								
R.	25	55.9	159.0	1.56	19	13	7.5	48.7
A.	29	62.1	166.5	1.68	27	16	9.9	52.2
P.	23	61.9	161.0	1.65	13	11	6.8	53.9
M.	19	64.1	164.9	1.70	6	5	3.1	60.9
K.	29	68.7	172.6	1.82	9	9	5.5	62.5
A.	23	64.3	175.2	1.78	12	11	6.8	57.2

Table 1. Physical Characteristics of Subjects.

HUMAN RACIAL RESPONSES

Indians. The subjects were in a basal state, and the measurements were made on the subjects in their own beds immediately after they had been awakened.

The subjects exhaled through a rubber mouth piece, a one way plastic valve, and a short length of rubber hose into the portable Muller-Franz respirometer described by Lehman (1953), and Montoge et al. (1958). Aliquot samples of expired air, which were about 0.3% of the total volume, were passed through Alcoa Alumina desiccant in a 50 cc glass syringe into a Model C Beckman Oxygen Analyzer. Expired air volumes at BTPS were reduced to STPD. Heat production was calculated from the following expression by the method proposed by Weir (1949):

$$\text{kcal/hr/m}^2 = \frac{V_E \times (1.046 - 0.05\% \text{O}_2 \text{E}) \times 60}{\text{S. A.}}$$

where:

V_E = minute volume of expired air

$\% \text{O}_2 \text{E}$ = % oxygen in expired air

S. A. = surface area in m^2

Bath calorimeter. The thermoregulated recirculating water bath calorimeter constructed and previously described by Carlson (1961) was utilized. It was similar to that used by Burton (1936). The bath contained 396 liters of water, and its temperature could be regulated within $\pm 0.1^\circ \text{C}$. The bath was installed in a room where the room air temperature could be controlled within $\pm 1.0^\circ \text{C}$. Water temperatures selected were 35°C , 33°C and 30.5°C , and room temperatures were maintained about 14°C lower to insure a constant rate of heat loss. Water and room temperatures were allowed to stabilize for 12 hours. The average amount of electrical energy required to maintain the water temperature in the calorimeter was measured at 6

MILAN

minute intervals. The factor 0.86 was used to convert watts to kcal/hr (Handbook of Chemistry and Physics).

The subject reclined in the bath with all except his face immersed in water. The subject's total heat loss was determined with a correction applied equal to the caloric equivalent of the water displaced by the subject. Total immersion time was one hour. Although heat production did not equal heat loss during this hour and true steady state conditions were not achieved, rates of change were constant during the last 30 minutes, and these data were used. This period is what Burton (1939) has termed a "dynamic steady state."

Heat production. Heat production was continuously monitored by the respirometer-oxygen analyzer combination utilized to measure basal metabolic rates.

Rectal temperature. An indwelling catheter type thermistor was inserted 10 cm into the rectum and secured to the buttock by waterproof tape. Temperatures were measured on a Yellow Springs Instrument Co. Telethermometer and recorded on the strip chart of an Esterline Angus Recorder.

Calculation. The Laws of Heat Transfer by Thermal Conduction have been summarized by Hardy (1949) and are analogous to Ohm's Law for electrical circuits. The fundamental equation for heat conduction in the steady state is:

$$H_D = \frac{KA(T_2 - T_1)}{d} \times t, \text{ gm cal}$$

where:

H_D = quantity of heat conducted

K = thermal conductivity, a constant

A = area of conducting surfaces

HUMAN RACIAL RESPONSES

T_2 and T_1 = temperatures of the warm and cool surfaces

t = time

d = thickness of the conductor

It follows that tissue insulation may be determined from the equation:

$$K_i = \frac{(T_r - T_w)}{H}$$

where:

K_i = tissue insulation $^{\circ}\text{C}/\text{kcal}/\text{m}^2/\text{hr}$

T_r = average rectal temperature

T_w = water temperature

H = heat loss ($\text{kcal}/\text{m}^2/\text{hr}$) measured over 30 minutes

For these calculations it is assumed that skin temperature is equal to water temperature and that regional gradients over the body have been obliterated. Although this assumption disregards the temperature of the boundary layer between the skin-water interface, the assumption has precedents (Carlson et al., 1958; Covino, 1960).

Determination of Body Fat

The skin fold calipers described by Best (1953) were used to measure the thickness of ten double folds of skin and subcutaneous fat at the sites recommended by Allen et al. (1956). Percentage of adiposity was determined from the total skinfold thickness minus 40 mm (the thickness of ten double folds of skin) according to Allen's formula. Percentage of adiposity was multiplied by 0.62 which corrected for water in adipose tissue (Brozek et al., 1954).

Statistical Treatment

These data were analyzed in a single classification analysis of variance.

RESULTS

Basal metabolic rates. Average basal metabolic rates and standard deviations were 47.6 ± 4.41 and 45.4 ± 4.91 kcal/m²/hr for the Eskimos and 42.7 ± 1.70 and 42.2 ± 3.92 kcal/m²/hr for the Indians. The basal metabolic rates of the soldiers were not measured. Lewis et al. (1961) have reported a mean value of 37.4 ± 3.66 kcal/m²/hr for 349 measurements on 29 British men with an average age of 29 years. This figure is close to the average metabolism of the soldiers in the 35°C bath. Each hour the Eskimos produced about 8 to 10 kcal and the Indians about 5 kcal more than the soldiers when surface area was used as the metabolic reference standard.

Calorimetric studies. A summary of the data showing the manner in which the three groups are similar or differ, and the level of significance attached to these differences is shown in Table 2. It is of more than passing interest that although there were no differences in the fall of rectal temperatures, the Eskimo group, in general, produced and lost the greatest amount of heat in the water baths at all temperatures.

The relation between an index of "effective thermal conductivity" and the physiological temperature gradient across which the energy is transferred is shown graphically for all subjects in Figure 1. The relation between tissue insulation, actually the reciprocal of conductivity, and the temperature gradient is shown in Figure 2.

HUMAN RACIAL RESPONSES

35° C BATH						
	SOLDIERS	INDIANS	ESKIMOS	E vs I	I vs S	E vs S
M	36.9	42.8	50.3	<.02	<.05	<.001
L	51	47	73	<.001	>.10	<.001
ΔT_r	-0.21	-0.38	-0.32	>.05	>.05	>.05
K_i	.029	.032	.021	<.001	<.05	<.001
33° C BATH						
M	39.4	50.9	54.7	>.10	<.01	<.01
L	66	62	86	<.001	>.50	<.01
ΔT_r	-0.46	-0.67	-0.56	>.05	>.05	>.05
K_i	.052	.053	.038	<.001	>.50	<.001
30.5° C BATH						
M	48.1	52.8	62.8	>.10	>.50	<.05
L	86	75	94	<.001	<.05	>.05
ΔT_r	-0.7	-0.9	-1.1	>.05	>.05	>.05
K_i	.071	.068	.057	<.001	>.05	<.001

Table II. Average values of metabolism (M) and heat loss (L) in kcal, m²/hr, fall in rectal temperature (ΔT_r) in °C and tissue insulation (K_i) in °C kcal, m²/hr for the three groups at the three bath temperatures. P values show the levels of significance which can be attached to the between group differences.

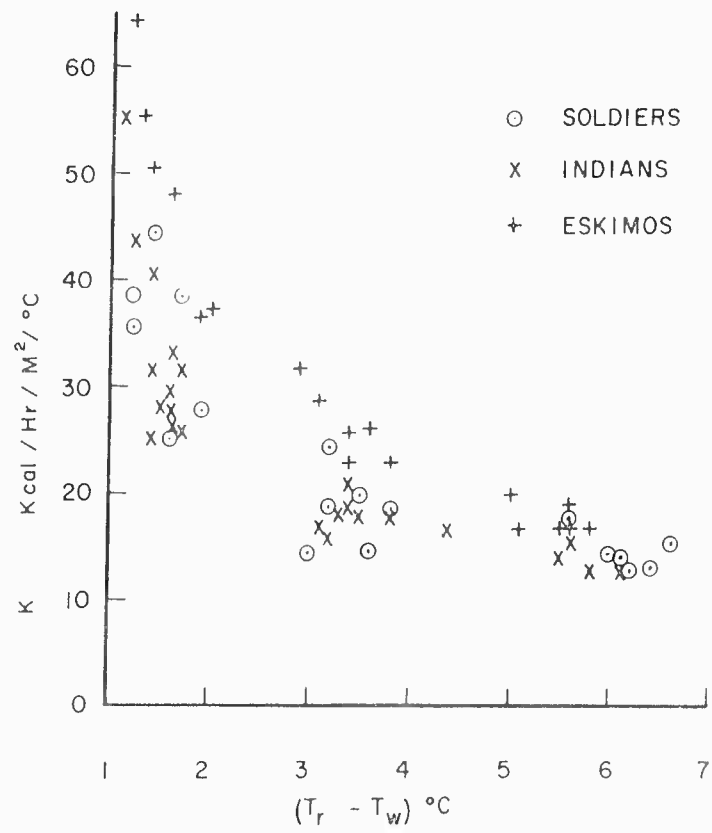

Figure 1. A graphical illustration of the relation between an index of thermal conductivity and the physiological temperature gradient.

HUMAN RACIAL RESPONSES

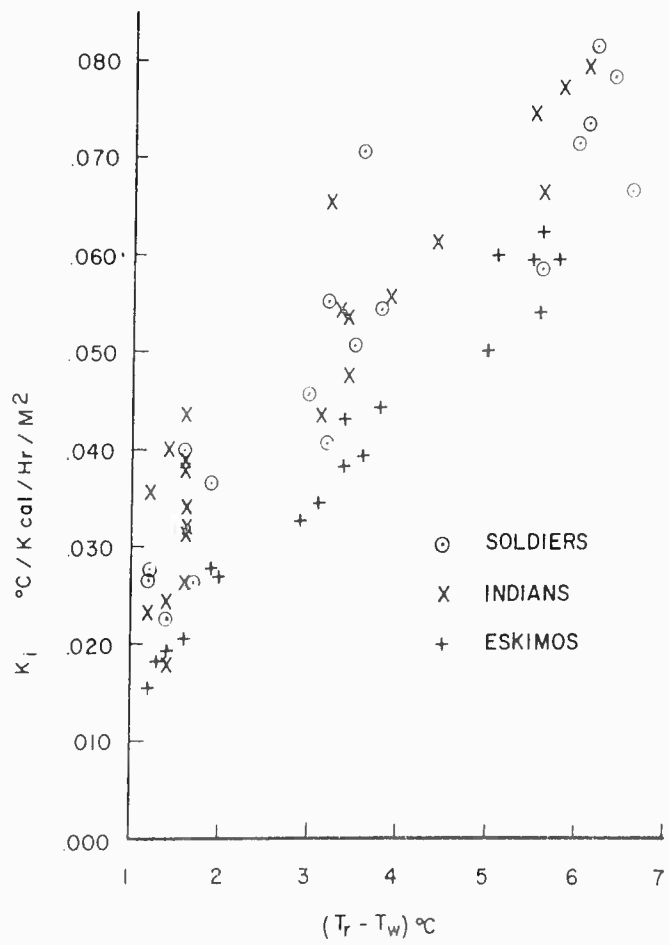

Figure 2. The relation between tissue insulation and the physiological temperature gradient.

MILAN

In Figure 3 is shown the relation between tissue insulation and the three bath temperatures. At all temperatures the Eskimos have significantly lower tissue insulations than the other groups. The Indians and soldiers are similar to each other and indistinguishable at 33° C. The three extrapolated curves intercept at about 36.5° C and at this bath temperature, under the conditions of this study, tissue insulation would presumably equal zero.

Percent body fat. The mean values for percent fat in the Eskimos, soldiers, and Indians were 6.6, 15.6 and 12.3. Although the Indians and soldiers were not significantly different from each other, the Eskimos were considerably leaner in body build. Coefficients of the regression line of tissue insulation versus percent body fat were 0.847, 0.309 and 0.657 at 35° C, 33° C and 30.5° C respectively. An analysis of covariance was then undertaken in which tissue insulations were adjusted for their regressions on percent body fat. At 35° C there were no differences between groups. At 33° C the differences were significant at the .05 level. At 30.5° C the differences were significant at the .01 level.

DISCUSSION

These experiments show that there are differences in total body heat loss and heat production between a sample of Eskimos, Indians, and soldiers immersed in temperature regulated baths. Although rates of heat loss and production were unchanging during the 30 minute period of measurement, the most serious criticism of the results of this experiment concerns non-steady state conditions, for rectal temperatures were falling.

It should be noted that there were no inter-group differences in the fall of rectal temperatures despite considerable differences in heat loss and production. In the 33° C bath the differences in

HUMAN RACIAL RESPONSES

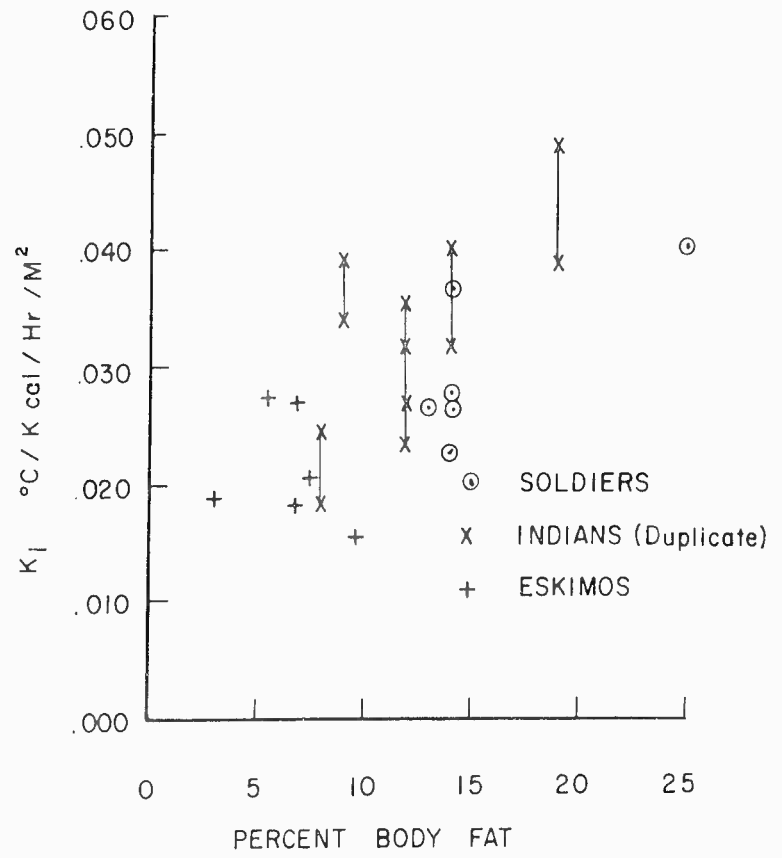

Figure 5. The relation between tissue insulation and bath temperatures.

MILAN

total heat loss and production between the soldiers and the Eskimos were highly significant. The first law of thermodynamics allows us to say that $M \pm D = H$ where M = metabolism, D = heat debt, and H = the combined losses of heat through conduction, convection, radiation, and evaporation (Carlson, 1954). We can assume that about 8% of M is evaporative heat loss. In the 33°C bath, then, Eskimo and soldier average metabolisms are 54.7 and 39.4 kcal/m²/hr. By subtracting 8% of these values we see that the Eskimos have 50 kcal/m²/hr and the soldiers 36 kcal/m²/hr available to lose to the colder bath water without incurring a heat debt. They lost 86 and 66 kcal/m²/hr, a difference of 20 kcal, and incurred body heat debts at the same rates. The differences between heat produced and total heat loss is then 36 kcal for the Eskimos and 30 kcal for the soldiers. The Eskimos are characterized by a greater energy flux through the system (a system which can be described as an isothermal energy converter). In addition a greater mass of the Eskimo peripheral tissue participates in this cooling. It is tempting to conclude that the Eskimos have smaller "cores" and larger "shells."

Others (Carlson et al., 1958; Pugh et al., 1960; Cannon et al., 1960) have shown that subcutaneous fat is of considerable importance in reducing heat loss in cold water. Hatfield et al. (1951) have reported that the thermal insulation of 1 cm of fat is $\frac{1}{0.0005}$ kcal/cm²/sec. The experiments of Cannon et al. (1960) showed that fat men achieved a higher maximum tissue insulation in cold water than thin men. Carlson et al. (1958) have reported tissue insulations that range between $0.10^{\circ}\text{C}/\text{kcal}/\text{m}^2/\text{hr}$ and $0.40^{\circ}\text{C}/\text{kcal}/\text{m}^2/\text{hr}$. Carlson's values are considerably higher than the tissue insulations reported here and are probably more nearly correct for steady state conditions above the critical temperature.

HUMAN RACIAL RESPONSES

LITERATURE CITED

1. Adams, T. and B. Covino. 1958. Racial variations to a standard cold stress. *J. Appl. Physiol.* 12:9.
2. Allen, T. H., M. T. Peng, K. P. Chen, T. F. Haung, C. Chang and H. S. Fang. 1956. Prediction of total adiposity from skin-folds and the curvilinear relationship between external and internal adiposity. *Metabolism.* 5:346.
3. Andersen, K. L., Y. Loyning, J. D. Nelms, O. Wilson, R. H. Fox and A. Bolstad. 1960. Metabolic and thermal responses to moderate cold exposure in nomadic Lapps. *J. Appl. Physiol.* 15:649.
4. Andersen, K. L., A. Bolstad, Y. Loyning and L. Irving. 1960. Physical fitness of arctic Indians. *J. Appl. Physiol.* 15:654.
5. Best, W. R. 1954. An improved caliper for measurement of skinfold thickness. *J. Lab. and Clin. Med.* 43:967.
6. Brown, G. M. and J. Page. 1952. The effect of chronic exposure to cold on temperature and blood flow of the hand. *J. Appl. Physiol.* 5:221.
7. Brown, G. M., J. D. Hatcher and J. Page. 1953. Temperature and blood flow in the forearm of the Eskimo. *J. Appl. Physiol.* 5:410.
8. Brown, G. M., G. S. Bird, L. M. Boag, D. J. Delahaye, J. E. Green, J. D. Hatcher, and J. Page. 1954. Blood volume and basal metabolic rate of Eskimos. *Metabolism.* 3:247.
9. Brozek, J., J. F. Brock, F. Fidaya and A. Keys. 1954. A skin-fold caliper estimation of body fat and nutritional status. *Fed. Proc.* 13:19.

10. Burton, A. C. and H. C. Bazett. 1936. A study of the average temperature of the tissues of the exchanges of heat and vasomotor responses in man by means of a bath calorimeter. *Am. J. Physiol.* 117:36.
11. Burton, A. C. 1939. The properties of the steady state compared to those of equilibrium as shown in characteristic biological behavior. *Cell. and Comp. Physiol.* 117:36.
12. Burton, A. C. and O. G. Edholm. 1955. *Man in a cold environment.* Arnold, London.
13. Carlson, L. D. 1954. *Man in a cold environment.* AAL, APO 731, Seattle.
14. Carlson, L. D., A. C. L. Hsieh, F. Fullington and R. W. Elsner. 1958. Immersion in cold water and body tissue insulation. *J. Aviation Med.* 29:145.
15. Carlson, L. D., A. Kawahata, K. Miller and R. W. Elsner. 1959. Internal heat of the body. *Fed. Proc.* 18:23.
16. Carlson, L. D. and H. L. Thursh. 1960. Human acclimatization to cold. AAL TR 59-18, APO 731, Seattle.
17. Cannon, P. and W. R. Keatinge. 1960. The metabolic rate and heat loss of fat and thin men in heat balance in cold and warm water. *J. Physiol.* 154:329.
18. Coffey, M. F. 1954. A comparative study of young Eskimo and Indian males with acclimatized white males. *Transactions Third Conference on Cold Injury*, Jos. Macy Foundation, N. Y.
19. Collins, H. B. 1954. Time depth of American linguistic groupings. *American Anthropologist.*
20. Covino, B. G. 1961. Temperature regulation in the Alaskan Eskimo. *Fed. Proc.* 20:209.

HUMAN RACIAL RESPONSES

21. Davis, T. R. A., D. R. Johnston and F. C. Bell. 1960. Seasonal acclimatization to cold in man. U.S.A. Med. Res. Lab. Rep. No. 386, Ft. Knox.
22. Davis, T. R. A. 1961. Experimental cold acclimatization in man. U.S.A. Med. Res. Lab. Rep. No. 457, Ft. Knox.
23. Downie, N. M. and R. W. Heath. 1959. Basic Statistical Methods. Harper, N. Y.
24. Elsner, R. W. 1960. Changes in peripheral circulation with exercise training. AAL TR-59-16, APO 731, Seattle.
25. Elsner, R. W., K. L. Andersen and L. Hermansen. 1960. Thermal and metabolic responses of arctic Indians to moderate cold. *J. Appl. Physiol.* 15:659.
26. Elsner, R. W., J. D. Nelms and L. Irving. 1960. Circulation of heat to the hands of arctic Indians. *J. Appl. Physiol.* 15:662.
27. Giddings, J. L. 1960. The archaeology of Bering Strait. *Current Anthropology.* 1:2.
28. Glaser, E. M., M. S. Hall and G. C. Whittow. 1959. Habituation to heating and cooling of the same hand. *J. Physiol.* 146:152.
29. Goldby, F., C. S. Hicks, W. J. O'Connor and D. A. Sinclair. 1938. A comparison of skin temperatures and skin circulation of naked whites and Australian aboriginals exposed to similar environmental temperatures. *Australian J. Exp. Biol. and Med. Sci.* 16:29.
30. Gottschalk, C. W. and D. S. Riggs. 1952. Protein-bound iodine in the serum of soldiers and of Eskimos in the Arctic. *J. Clin. Endocrin. and Metab.* 2:235.
31. Hammel, H. T., R. W. Elsner, D. H. LeMessurier, H. T. Andersen and F. A. Milan. 1959. Thermal and metabolic responses of the Australian aborigine exposed to moderate cold in summer. *J. Appl. Physiol.* 14:605.

32. Hammel, A. T. 1960. Thermal and metabolic responses of the Alacaluf Indians to moderate cold exposure. W. A. D. D. Rep. 60-633, Wright Patterson AFB.
33. Hardy, J. D. 1949. Heat transfer. In Newburgh, L. H. Physiology of Heat Regulation and the Science of Clothing. Saunders, Philadelphia.
34. Hardy, J. D. 1961. The physiology of temperature regulation. *Physiol. Rev.* 41:521.
35. Hatfield, H. S. and L. G. C. Pugh. 1951. Thermal conductivity of human fat and muscle. *Nature.* 168:133.
36. Hicks, C. S. 1931, 33, 34, 38a. In Carlson, L. D. and H. L. Thursh. 1960. Human acclimatization to cold. A selected, annotated bibliography of the concepts of adaptation and acclimatization as studied in man. AAL TR 59-18, APO 731, Seattle.
37. Hygaard, A. 1941. Studies on the nutrition and physio-pathology of Eskimos. Det Norske Videnskaps Akademi, Sk. No. 9, Oslo.
38. Iampietro, P. F., R. F. Goldman, E. R. Buskirk and D. E. Bass. 1959. Responses of negro and white males to cold. *J. Appl. Physiol.* 14:798.
39. Irving, L., K. L. Andersen, A. Bolstad, R. W. Elsner, J. A. Hildes, Y. Loyning, J. D. Nelms, L. J. Peyton, and R. O. Whaley. 1960. Metabolism and temperature of arctic Indian men during a cold night. *J. Appl. Physiol.* 15:635.
40. Kawahata, A. and T. Adams. 1961. Racial variations in sweat gland distribution. *Proc. Soc. Exper. Biol. and Med.* 106:862.
41. Keeton, R. W., E. H. Lambert, N. Glickman, H. H. Mitchell, J. H. Last and M. K. Fahnestock. 1946. The tolerance of man to cold as affected by dietary modifications; protein

HUMAN RACIAL RESPONSES

versus carbohydrates, as the effects of variable protective clothing. *Am. J. Physiol.* 146:66.

42. Krogh, A. and M. Krogh. 1913. A Study of the Diet and Metabolism of Eskimos. Bianco Luno, Copenhagen.
43. Larsen, H. and J. Meldgaard. 1958. Paleo-Eskimo cultures in Disko Bugt, West Greenland. *Medd. om Gron.* 161:2, Copenhagen.
44. Laughlin, W. S. and G. H. Marsh. 1951. A new view of the history of the Aleutians. *Arctic.* 3:175.
45. LeBlanc, J. 1956. Evidence and meaning of acclimatization to cold in man. *J. Appl. Physiol.* 9:395.
46. Lehman, G. *Praktische Arbeitsphysiologie.* Georg Thieme Verlag.
47. Lewis, H. E., J. P. Masterton and S. Rosenbaum. 1961. Stability of basal metabolic rate on a polar expedition. *J. Appl. Physiol.* 16:397.
48. MacHattie, L., P. Haab and D. W. Rennie. 1960. Eskimo metabolism as measured by the technique of 24-hour indirect calorimetry and graphic analysis. AAL TR 60-43, APO 731, Seattle.
49. Meehan, J. P., A. Stoll and J. Hardy. 1954. Cutaneous pain threshold in the Alaskan Indian and Eskimo. *J. Appl. Physiol.* 6:397.
50. Meehan, J. P. 1955. Body heat production and surface temperatures in response to a cold stimulus. AAL Proj. 7-7951. Rep. No. 2, APO 731, Seattle.
31. Meehan, J. P. 1955. Individual and racial variations in a vascular response to a cold stimulus. *Military Med.* 116:330.

MILAN

52. Milan, F. A. 1960. Swedish Lappland: A brief description of the dwellings and winter living techniques of the Swedish Mountain Lapps. AAL TR 60-7, APO 731, Seattle.
53. Milan, F. A., R. W. Elsner and K. Rodahl. 1961. Thermal and metabolic responses of men in the Antarctic to a standard cold stress. *J. Appl. Physiol.* 16:401.
54. Montoye, H. J., W. D. vanHuss, E. P. Reineke and J. Cockrell. 1958. An investigation of the Miller-Franz calorimeter. *Arbeitsphysiol.* 17:28.
55. Morrison, P. R. 1957. Body temperatures in aboriginals. *Fed. Proc.* 16:90.
56. Page, J. and G. M. Brown. 1953. Effect of heating and cooling the legs on hand and forearm blood flow in the Eskimo. *J. Appl. Physiol.* 5:753.
57. Pecora, J. S. 1948. Cold pressor test in the study of acclimatization to cold. AAL Rep. 21-01-005, APO 731, Seattle.
58. Prosser, C. L. 1959. The "origin" after a century: prospects for the future. *American Scientist.* 47:536.
59. Pugh, L. G. C., O. G. Edholm, R. H. Fox, H. S. Wolff, G. R. Hervey, W. H. Hammond, J. M. Tanner and R. H. Whitehouse. 1960. A physiological study of channel swimming. *Clin. Sci.* 19:257.
60. Rennie, D. and T. Adams. 1957. Comparative thermoregulatory responses of negroes and white persons to acute cold stress. *J. Appl. Physiol.* 11:201.
61. Rodahl, K. J. 1952. Basal metabolism of the Eskimo. *Nutrition.* 48:359.
62. Rodahl, K. and G. Bang. 1956. Endemic goiter in Alaska. AAL TN 56-9, APO 731, Seattle.

HUMAN RACIAL RESPONSES

63. Rodahl, K. and G. Bang. 1957. Thyroid activity in men exposed to cold. AAL TR 57-36, APO 731, Seattle.
64. Rodahl, K. and D. Rennie. 1957. Comparative sweat rates of Eskimos and Caucasians under controlled conditions. AAL TR Proj. 8-7951, No. 7, APO 731, Seattle.
65. Scholander, P. F., K. L. Andersen, J. Krog, F. V. Lorentzen and J. Steen. 1957. Critical temperature in Lapps. *J. Appl. Physiol.* 10:231.
66. Scholander, P. F., H. T. Hammel, K. L. Andersen and Y. Loyning. 1958. Metabolic acclimation to cold in man. *J. Appl. Physiol.* 12:1.
67. Scholander, P. F., H. T. Hammel, J. S. Hart, D. H. LeMessurier and J. Steen. 1958. Cold adaptation in Australian aborigines. *J. Appl. Physiol.* 13:219.
68. Simpson, G. G., C. Pittendrigh and L. Tiffany. 1957. *Life*. N. Y., Harcourt Brace.
69. Tobias, P. V. 1961. Physique of a desert folk. *Natural Hist.* LXX:17.
70. Ward, J. S., G. A. Bredell and H. G. Wenzel. 1960. Responses of Bushmen and Europeans on exposure to winter night temperatures in the Kalahari. *J. Appl. Physiol.* 15:667.
71. Washburn, S. L. 1960. Tools and human evolution. *Scientific American.* 3:63.
72. Weir, J. B. V. 1949. New methods for calculating metabolic rate with special reference to protein metabolism. *J. Physiol.* 109:1.

MILAN

DISCUSSION

ADAMS: Would your metabolic rates measured in the bath calorimeter compare with those measured under basal conditions?

MILAN: I would say they would be about the same.

HANNON: Were your basal metabolic rates measured under bed rest conditions?

MILAN: Yes, and I think, as pointed out by Henderson in 1926, that there is a relationship between basal metabolic activity and the circulation. Thus, if you have a slightly higher basal metabolism, the energy flux is somewhat different, since if you subscribe to the view of Hardy (1961) the hypothalamus regulates for temperature, not energy flux.

KLEIBER: I notice that there is a discrepancy from data published by Swift,* who reported that his college students began shivering when their skin temperatures went down to 90° F. But now the newer data seem to indicate that practically all human beings have much higher skin temperatures at a critical level than the level at which the metabolic temperature regulation starts. Is there an answer to this discrepancy?

MILAN: I do not know.

ADAMS: I might offer one suggestion: the method of taking the average skin temperature makes quite a difference, if this measurement was calculated in such a way as to give proportionalities to each site different from conventional standards.

*Swift, R. W. 1932. The effect of low environmental temperature upon metabolism. II. The influence of shivering, subcutaneous fat, and skin temperature on heat production. *J. Nutr.* 5:227-229.

HUMAN RACIAL RESPONSES

KLEIBER: I was tempted to conclude that these college students had a non-shivering metabolic increase, but this is a dangerous conclusion.

JOHANSEN: I was thinking of the rather profound seasonal changes in BMR that Yoshimura has reported for his Japanese subjects. Is this not out of proportion with what has been found in other populations?

MILAN: Yes. Professor Yoshimura said, when he was here, that he tried to do his studies under strict basal conditions, and I think the Japanese spend more time and efforts on their measurements of basal metabolism than we do.

PROSSER: Would you conclude that these higher BMRs in the Eskimos are not related to specific dynamic action?

MILAN: I should hesitate to conclude anything. I know only that the experiments of Rodahl (1952) indicated that the high Eskimo BMR was related to the high protein diet and possibly the specific dynamic action of this diet. However, the recent experiments of MacHattie et al. (1960) which investigated the 24 hour metabolism of the Anaktuvuk Eskimos seem to indicate otherwise. Heat production and the energy fraction contributed by catabolism of carbohydrate, fat and protein were determined by indirect calorimetry and measurements of urinary nitrogen. They reported no correlation between the rate of night metabolism and the amount of protein or fat fuel energy fraction and suggested that other factors than specific dynamic action were involved as the cause of the elevated resting metabolism of these people.

HANNON: In your particular experiments the BMRs are measured after 5 days on a hospital diet. Therefore if the elevated metabolic rate is due to a specific dynamic action it would seem to have lasted over a period of 5 days.

HART: I wanted to ask about this, too, because we had some occasion from our Eskimo studies at Pangnirtung to see long lasting effects even on some people who are living on a white man's diet

MILAN

for 4 or 5 days. They still had a 25% elevation in heat production. Is there any explanation for this? I do not understand how dynamic action can last so long.

EAGAN: Yoshimura, Iida and Koishi (1952)* have shown that when the protein fraction in the diet is increased there is an increase in BMR which persists for several days after the protein intake is reduced to normal. This result was obtained by merely doubling the protein intake from a normal 75 grams to 150 grams per day.

MORRISON: What is the implication of this? Are the amino acids stored away and then used gradually? Would the high protein diet encourage their storage?

HANNON: There is a very confusing picture with respect to the mechanism of specific dynamic action. We attempted to get at this one time by infusing an animal intravenously with amino acids to see how they affected his metabolism. Nothing happened, so we discontinued the experiments.

MORRISON: Nothing happened? Are there not reports in literature showing that infused amino acids give a normal specific dynamic action?

HANNON: This was intravenous infusion where two different amino acids--glycine and glutamate--were tested. Neither caused any increase in the metabolic rate. It is interesting that you do get the specific dynamic action when the animal eats protein. This might suggest that the mechanism of SDA may have something to do with gut absorption; I do not really know.

ADAMS: This picture on the SDA effect of glycine is really confused. Dr. Carlson tried feeding glycine and noted a subsequent

*Yoshimura, H., T. Iida and H. Koishi, 1952. Studies on the reactivity of skin vessels in extreme cold. Part III. Effects of diets on the reactivity of skin vessels. *J. Exp. Biol.* 25: 107-119.

HUMAN RACIAL RESPONSES

increase in metabolic rate, if I remember correctly. In similar experiments we did not see anything in Caucasian soldiers. In a racial study of Eskimos from Anaktuvuk Pass a few years ago we observed a maintenance of the raised metabolic rate even after living for 2 weeks on Ladd Air Force Base and eating in the hospital. The problem of course is they were on an ad libitum diet and we had no idea of the proportions of the various foods that they selected for their meals or the supplemental foods they may have eaten in town. However there was no apparent change in metabolic rate from when they first brought them down to when they left.

HANNON: It has been my observation, from watching them in the hospital cafeteria line, that they avoid salads and green vegetables. They like potatoes and meat, so they may not be changing the nature of their diet as much as you might anticipate.

HART: Dr. J. A. Hildes (University of Manitoba) and I measured the metabolic rate of coppermine Eskimos who had been hospitalized at Edmonton, Alta., for several months. We measured the metabolic rate of coppermine Eskimos who had been hospitalized at Edmonton, Alta., for several months. We measured metabolism all night in the sleeping situation and found that it was identical to that specified by the DuBois standards corresponding to the weight and height of these men. There did not seem to be any long term elevation of BMR after they had been living under white man's conditions.

HANNON: Are these ambulatory patients or bed patients?

HART: They were hospitalized, but there were no active tuberculosis among the test subjects. They had been suffering various ailments, but nothing of a severe metabolic nature.

ADAMS: How long had they been down?

HART: This varied a great deal.

IRVING: Some of them were chronic, almost permanent?

HART: Yes. Others were there for several months.

MILAN

ADAMS: It might be important to notice the proportional adjustment of their diet.

HART: These men were eating a normal white man's diet.

HANNON: Your controls were in the same place?

HART: There were no controls in this case. It was just the Eskimo compared to DuBois standards.

ADAMS: I do not feel, as Dr. Rodahl pointed out in the recent reviews, that anxiety plays too much of a role in these basal metabolic rates. In repeated examinations you would expect the effects of anxiety to be reflected by a successive reduction in the metabolic rate. Thus it may have an effect in one or two measurements, but not after a series.

HART: That is my impression.

MILAN: Dr. Hannon, there has been considerable interest in the vascular responses of people who have been acclimatized or habituated to a cold bath, and Dr. Eagan has some information that was obtained on the subjects we had here last winter. I wonder, since we have some time left, if he might present some of the data he obtained.

HANNON: All right.

HUMAN RACIAL RESPONSES
LOCAL COLD ADAPTATION AND HABITUATION

C. J. Eagan

When experiments are done on any animal that is conscious of its environment, the role of the higher nervous centers in modifying physiological responses cannot be ignored. Bernard (1865)* in "An introduction to the study of experimental medicine" (1927) has stated:

no animal is ever absolutely comparable with another--
neither is the same animal comparable with himself at
different times when we examine him, whether because
he is in different conditions, or because his organism
has grown less sensitive, by getting used to the substance
given him or to the operation to which he is subjected.

Davis (1934)** described modifications in the galvanic reflex as a result of daily repetition of a stimulus. Other examples could be cited. A progressive reduction in response to a repeated stimulus has been termed "habituation" by Glaser and Whittow (1953)***. "Habituation" is defined as "the process of forming into a habit or accustoming" and it is implied that "it depends on the mind, that it is reversible, and that it may involve the diminution of normal responses or sensations" (Glaser, Hall, and Whittow, 1959****).

This is a type of adaptation. Where the habituation is characterized by a reduction in response to a cold stimulus, then it is a "cold adaptation." In man it may be the most common type of cold adaptation which occurs.

I propose that there are two types of habituation, specific and general. "Specific habituation" is specific to the repeated stimulus

*Bernard, C. 1865. An introduction to the study of experimental medicine. Henry Schuman, Inc. 1927. 226 pp.

**Davis, R. C. 1934. Modifications of the galvanic reflex by daily repetition of a stimulus. *J. Exp. Psychol.* 17:504-535.

***Glaser, E. M. and G. C. Whittow. 1953. Evidence for a non-specific mechanism of habituation. *J. Physiol.* 122:43P.

****Glaser, E. M., M. S. Hall, and G. C. Whittow. 1959. Habituation to heating and cooling of the same hand. *J. Physiol.* 146:152-164.

MILAN

and specific to the part of the body which is repeatedly stimulated. "General habituation" might be explained as a change in the psychological "set" of the subject relevant to the conditions of experimentation so that he is no longer apprehensive, either consciously or unconsciously, at the time of the test.

These two types of habituation can develop simultaneously. Both depend upon a change in the manner in which the central nervous system interprets its afferent impulses. Both involve a progressive diminution in response to a repeated stimulus. Where the stimulus is the application of severe cold, specific and general habituation are manifested by reduced pain sensation and by reduced vasoconstrictor activity, respectively.

Both types of habituation as well as a local vascular adaptation were demonstrated in experiments done at the Arctic Aero-medical Laboratory (Eagan, 1960a*, 1960b**, 1961***). In all experiments, regimens of unilateral cold exposure ("test" side only) followed by simultaneous bilateral comparison ("test" vs. "control") were used in investigations of local tissue cold adaptation in the fingers of man. A summary of these experiments follows.

Chronic hand cooling of moderate intensity (12 hours per day with finger temperature between 10°C and 15°C for ten

*Eagan, C. J. 1960a. Topical adaptations to cold in the extremities. Proc. XI Alaskan Sci. Conf. pp. 184-185.

**Eagan, C. J. 1960b. Unilateral cold adaptation to recurrent ice water immersion. *Physiologist*, 3(3):51.

***Eagan, C. J. 1961. Habituation to recurrent ice water immersion of the finger. *Physiologist*, 4(3):31.

HUMAN RACIAL RESPONSES

days) resulted in a less intense initial vasoconstriction, less variability in digital blood flow and a 17% greater average heat loss, during a 30-minute period of ice-water immersion. Fingers of the test hand cooled more slowly than the control fingers during exposure to cold air. Pain sensation tended to be less for the test hand, especially for the fingers; this type of cold adaptation was termed "specific habituation"--specific to the cold stimulus and to the part of the body stimulated.

Recurrent finger cooling of severe intensity (six 5-minute ice-water immersions per day for 17 days) caused a marked, specific habituation to cold pain. There was no essential difference between the vascular reactions of test and control fingers when they were tested in ice water. Prolonged recurrent finger cooling (six 10-minute ice-water immersions per day for 125 days) confirmed the finding that specific habituation to pain could develop in the absence of local vascular cold adaptation. However, the subjects did show higher finger temperatures (test and control fingers alike) in ice water, compared with other subjects being tested for the first time. This was concluded to be a "general habituation" to the conditions of the experiment which resulted in less vasoconstrictor outflow to fingers in ice water.

It is considered that the results on general habituation are highly relevant to what has been discussed above by Milan. Many racial differences in the responses of the extremities to cooling have been attributed either explicitly or implicitly to localized vascular adaptations. These differences may on the contrary be related to the degree of habituation to cold exposure and the experimental conditions. Further, the energy state of the subject at the time of the test is not always taken into account.

A comparison of the responses to finger cooling in four groups of subjects is demonstrated in Table III and Figure 4.

The habituated group consisted of the six USAF airmen who had each immersed one middle finger in ice water 750 times over the

AVERAGED RESPONSES FOR 4 GROUPS (6 subjects in each) DURING STANDARD IMMERSION OF FINGERS IN 0.0°C WATER

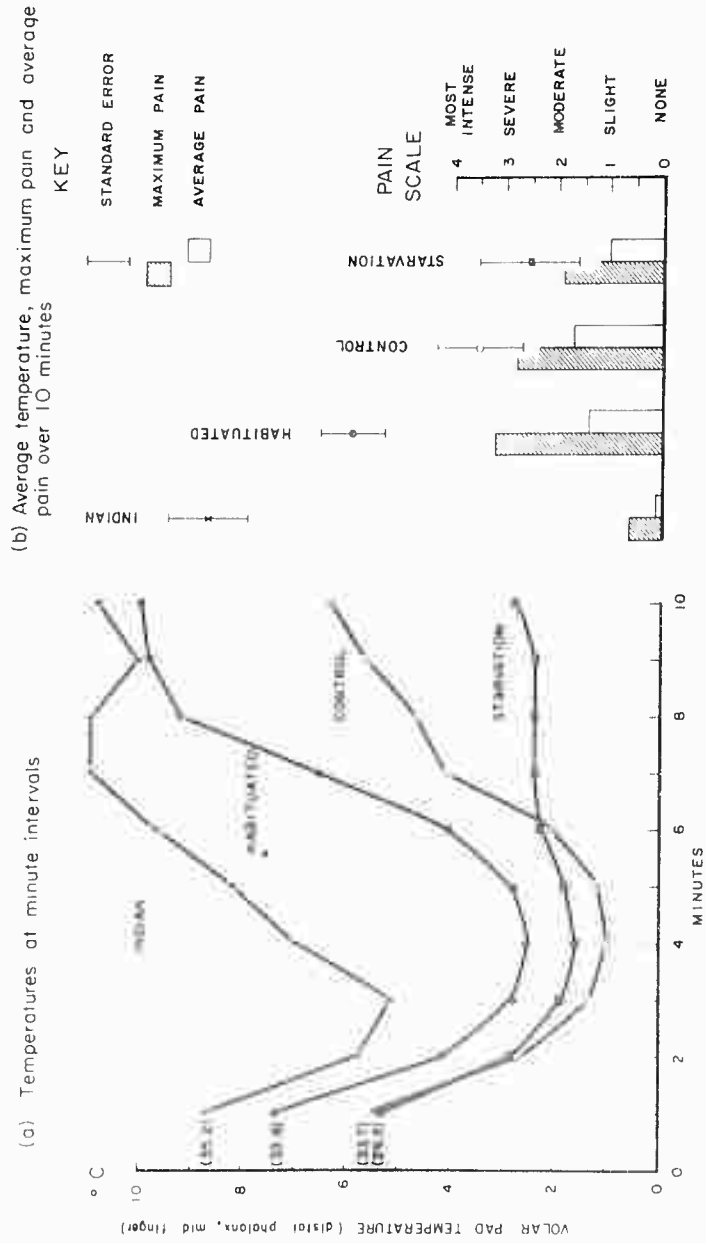

Figure 4. Comparisons of temperature and pain responses on four groups of subjects. The average responses of the control fingers of the habituated group on days are compared with the responses of the right middle fingers of the other groups. Average pre-immersion finger temperatures are shown in brackets. All tests were done under standard conditions.

HUMAN FACIAL RESPONSES

Subject group	No. of subjects	Energy state of subjects BMR (kcal/m ² /hr)	Rectal temp. (° C)	Average finger temp. (° C)
Indian	6	42.20 ± 1.60 *	36.80 ± 0.10	8.74 ± 0.77
Habituated	6	34.72 ± 0.75	36.84 ± 0.04	5.93 ± 0.61
Control	6	35.35 ± 1.04 **	36.77 ± 0.10	3.45 ± 0.77
Starvation	6	30.56 ± 1.59	37.09 ± 0.05	2.57 ± 0.94

Significance of differences (P)

Indian vs. habituated	< 0.01	ns ***	< 0.05
Indian vs. control	< 0.01	ns	< 0.001
Indian vs. starvation	< 0.001	< 0.05	< 0.001
Habituated vs. control	ns	ns	< 0.05
Habituated vs. starvation	< 0.05	< 0.01	< 0.05
Control vs. starvation	< 0.05	< 0.05	ns

*Standard error

* *BMR was measured on only four of the control subjects

* * *Not significant (P > 0.05)

Table III. Relation between energy states of subjects and average temperatures of fingers immersed in 0 ° C water for 10 minutes (under standard test conditions for all groups).

MILAN

previous 125 days. The averaged responses of the control fingers of this group were compared with the averages for the right middle fingers of each of the other groups. The average age for the habituated group was 27 years.

The Indian group consisted of six Alaskan natives from the Tetlin Reservation. They normally spent the greater part of the daylight hours out-of-doors, attending traplines, etc. These subjects were tested during the latter part of December, when it would be expected that they would have endured considerable recent cold exposure. At the time of this test, they had lived at the laboratory for one week under a regimen of restricted indoor activities. Their meals were taken entirely at the USAF Hospital cafeteria. During the week, they had been subjected to several oxygen consumption measurements and finger immersions in ice water, in connection with another study. Hence, they were accustomed both to the test and to the experimenter. Their average age was 23 years.

The control group consisted of six subjects who were engaged in indoor occupations and five of whom were employed at the laboratory. They were at ease with the experimenter but were not accustomed to the test. It was considered that they were comparable with the habituated group except for their unfamiliarity with the test. Their average age was 30 years.

The starvation group consisted of six subjects who were tested 1 or 2 days after returning from a regimen of starvation in the cold. They had lived for 5 days camped at individual sites on river ice, without food or sufficient thermal protection, in interior Alaska during the month of February. They were all accustomed to recent cold exposure and to the experimenter, and four of the six were accustomed to the test. Their average age was 27 years.

Every effort was made to have test conditions the same for the four groups. In all tests the compared fingers were immersed equal depths (2.8 ± 0.1 cm) in 0.0° C water for 10 minutes. The water bath was stirred equivalently in all tests. Temperature of

HUMAN RACIAL RESPONSES

the distal digital volar pads was measured using the one set of thermocouples which were always placed on comparable positions on the fingers.

Prior to tests the subjects slept overnight in a comfortable environment at the laboratory. Standard procedures were followed such that subjects were post-absorptive and normothermal at the time of tests. All tests were done between 0700 and 1000 hours in the morning. Oral and rectal temperatures were taken and basal oxygen consumption was measured while the subject remained in bed. Immediately after the subject arose from bed he was instrumented and with arms in the dependent position the middle fingers were immersed.

In all tests the estimated intensity of pain sensations from each immersed finger was recorded at each minute. (See pain intensity scale on Figure 4.) "Maximum pain" is the highest single estimate during the test, while "average pain" is the cumulative minute total divided by the time (10 minutes).

It must be emphasized that it is the responses of the control fingers of the test subjects (habituated group) that are compared with the responses of the right middle fingers of the other three groups. Figure 4 shows that in the capability for maintaining high finger temperature during ice water immersion the progression among the groups was Indian > habituated > control > starvation (although the difference between the control and starvation groups was not significant). The pain suffered by the habituated and control groups was roughly the same, while that of the starvation group was somewhat less, and in the Indians it was almost negligible. Thus there was no simple relationship between pain and finger temperature.

Table III shows the relation between the energy states of the subjects as they rested in bed just before the finger immersion test and the average finger temperatures maintained in the ice water. A direct relationship between metabolic rate and finger

temperature during immersion is strikingly demonstrated by the Indian and starvation groups. It is notable that rectal temperature is higher in the starvation group than in the others, therefore, finger temperature need not be related to the central thermal state. The most important results relevant to the assessment of local cold adaptation in vascular responses are shown in the comparisons of habituated and control groups. BMR and rectal temperature were the same for both. Yet the habituated group maintained a significantly higher average finger temperature ($P < 0.05$). Finger temperatures of the groups just before immersion were in the progression: Indian $>$ habituated = control $>$ starvation. The values in $^{\circ}\text{C}$ were, respectively, 35.2 ± 0.16 , 33.8 ± 0.28 , 33.7 ± 0.40 and 29.5 ± 1.53 . The mean finger temperature of the Indians was significantly higher than that of the others ($P < 0.05$) but the differences between the other means were not statistically significant.

General conclusions. It was shown that cold exposure of the human hand can cause a local vascular cold adaptation, or a marked, specific habituation to cold pain, according to the duration and intensity of the local cooling. Further, it was shown that a general habituation to the test procedure gives results which could be mistaken for a local vascular cold adaptation.

In conditions where man works outdoors in cold climates, it is likely that he will endure prolonged periods of moderate hand cooling and occasional periods of severe cooling. Hence, he might maintain higher finger temperatures through a vascular adaptation, and suffer less pain, even when finger temperatures were very low, through specific habituation. These adaptations, combined with a general habituation to the environment, could result in marked improvements in manual efficiency as the cold season progressed.

Yet another factor, which is incidental to these adaptations, may favor the maintenance of higher peripheral temperatures in outdoor workers. This is the higher basal metabolic rate which has been measured in Eskimos and northern Indians. Whether the higher BMR of these northern natives is mainly related to diet (Yoshimura et al., 1952*) or to genetic differences has not yet been resolved conclusively.

*Yoshimura, H., K. Iida, and H. Koishi. 1952. Studies on the reactivity of skin vessels to extreme cold. Part III. Effects of diets on the reactivity of skin vessels to cold. *Jap. J. Physiol.* 2:310-315.

THERMOREGULATION IN MAMMALS
FROM THE TROPICS AND FROM HIGH ALTITUDES*

Peter Morrison

The title presents something of a problem since there may well be no real entity "thermoregulation in tropical mammals" such as we see in other environments as the desert or the arctic which make special demands and have elicited special physiological capabilities. The tropics are distinguished in a negative rather than in a positive sense, by the lack of demands, at least of thermoregulatory demands, which are placed on the inhabitants. As has been pointed out, this region has a much better claim to the title of "temperate" than do our own middle latitude regions where extremes of temperature and rainfall are characteristic. But there are certain groups of animals which may be considered characteristic of these regions so that we can at least discuss thermoregulation in "some tropical mammals." However, these may well be characterized by a deficiency in regulatory ability rather than any special attributes for life there. The monotremes, and the edentates, might be considered in this category, but these groups have already been reviewed as primitive forms by Dr. Johansen. So I propose to survey first, the marsupials, then a primitive eutherian group, the Chiroptera, and finally the more advanced group of the Primates; all of which we can think of as characteristically tropical, although some representatives extend beyond this zone.

*Much of the data discussed in this paper is as yet unpublished. Studies on Brazilian monkeys were carried out with J. Simoes, Jr., on the pigmy marmosette with E. Middleton; on new world tropical bats with B. K. McNab, who also participated together with K. Kerst and W. H. Holthaus in the studies on high-altitude mammals. Support for these studies has been variously received from the Guggenheim Foundation, the U. S. Educational Foundation in Australia, NSF, NIH, PHS, WARF, ONR, and the Rockefeller Foundation.

Marsupialia

The marsupials have often been stigmatized as indifferent homeotherms usually because of the low reported level of the body temperature (T_B). But this conclusion suffers on three counts; first, a somewhat lower T_B is a poor criterion of homeothermism, we do not consider birds to be more homeothermic than mammals simply because they maintain a higher T_B ; second, a fairly limited assortment of marsupials has been studied; and third, since most marsupials are nocturnal, their study by diurnal physiologists has resulted in a falsely low estimate of their T_B level.

The first figure shows the relation between body temperature and ambient temperature (T_A) in a small American (brown) opossum (Didelphidae) in day and night. The diurnal values are quite distinct from the nocturnal ones, but both are accurately regulated (over a range) in response to cold. This relation (T_B vs T_A) describes the sum of regulatory activities with a horizontal curve representing complete regulation and one with a 45° slope (reference line), representing the absence of regulation seen in a poikilotherm. In addition to the slope, we must also consider the relation of the curve to the reference line since an animal may have a fairly labile T_B and yet maintain it well above the T_A . A third criterion of regulation is the variability of the T_B around the mean curve, but this may sometime provide a spurious index, since the scatter may only reflect a variation in the circumstances under which the measurements were made.

Figure 2 compares a rat-sized Australian representative (Dasyuridae) with an even more striking diurnal depression, near noon its T_B is about 34° C, but at night it is 38° C. Since the latter level is equivalent to that in the dog, Chaetocercus can hardly be considered defective or primitive in its level of regulation. But this is a form which can show a daily torpor. Another smaller relative (Antechinus) shows an even higher level during periods of activity (to 40°) although these periods do not follow a 24-hour cycle. Accordingly, it is necessary to identify any daily (or other) cycle and choose either or both, the maximum and minimum periods--the active and resting phases--to characterize the species.

ADAPTATIONS TO TROPICS AND ALTITUDES

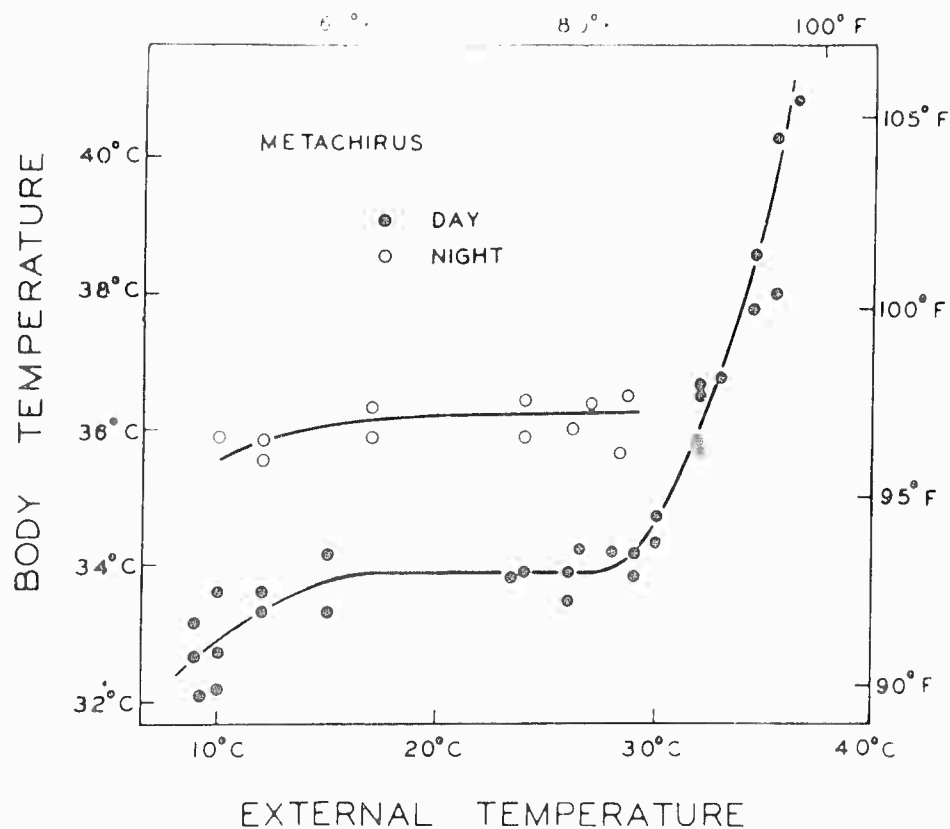

Figure 1. T_B as a function of T_A in the brown opossum (*Metachirus nudicaudatus*) showing the day-night difference.

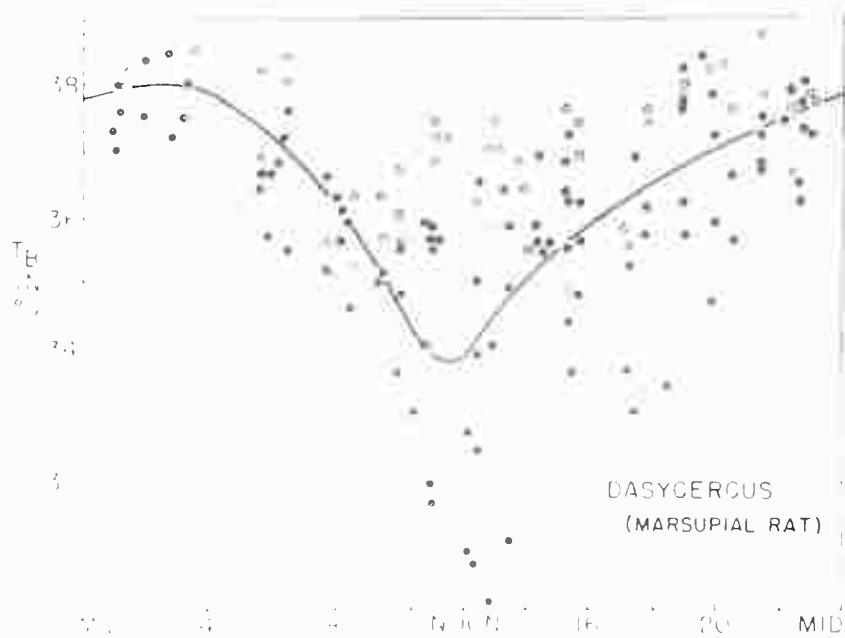

Figure 2. T_B in the Crest tailed marsupial rat (*Dasyercus cristicauda*) as a function of hour of day.

Figure 3 represents an interesting form, the bilby. This is a desert representative of the small group of bandicoots (Peramelidae) which further emphasizes the independence in the day and night "settings" of the "thermostat." The daytime (inactive) T_B declined steadily through the course of the experiments, but time played no part in the level of the active temperature which stayed steady at 37° . These two states need not differ very much in activity but merely "wakefulness." The T_B after forced activity in the daytime never reached the natural nighttime level. Similarly, forced activity at night did not raise the T_B at all. So these are not passive noncommitants of extra heat production, but rather are maintained levels that are set by the animal.

Figure 4 recasts these data into a 24-hour cycle to bring out this very sharp nocturnal pattern. Like the brown opossum, the bilby regulates to a different level during day and night (Fig. 5). The bilby has excellent regulation to cold and this may seem contradictory since it is a desert species which comes from the Australian "center" where a high T_A is the rule. But the bilby shows no evaporative cooling and if put in a hot room at 40° C, elevates its T_B by $4-6^{\circ}$ C within an hour and must be removed to avoid heat death (Robinson and Morrison, 1957).

By contrast, Figure 6 shows another bandicoot with fair regulation to heat, with the T_B curve crossing the isothermal line to give T_B lower than the T_A . Of course, in terms of the slopes, what would be rather poor regulation to cold represents rather good regulation to heat, and yet this animal comes from the coastal regions, which are considerably wetter and cooler than the "center." So it is of interest that a desert animal need not be characterized by the ability to maintain itself under desert conditions, while an animal from a less rigorous environment can do better. The answer, of course, is in the stringent requirements of desert life, such that the bilby must always use microclimatic evasion to avoid the expenditure of water.

The short-nosed bandicoot showed an interesting feature in relation to the topic of seasonal molification discussed by Dr. Hart. These animals always showed good "cold" regulation at night (Fig. 6), and in the winter they regulated well during the day or night.

ADAPTATIONS TO TROPICS AND ALTITUDES

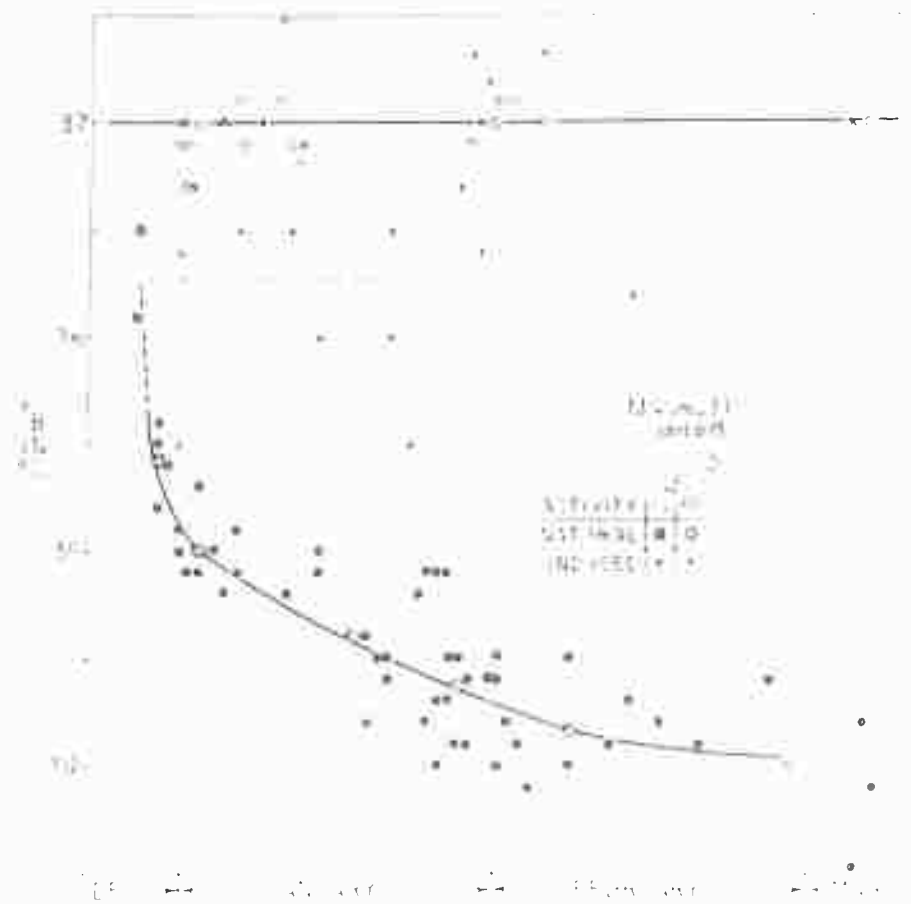

Figure 5. T_B in the rabbit bandicoot or bilby (*Macrotus lagotis*) during continued captivity.

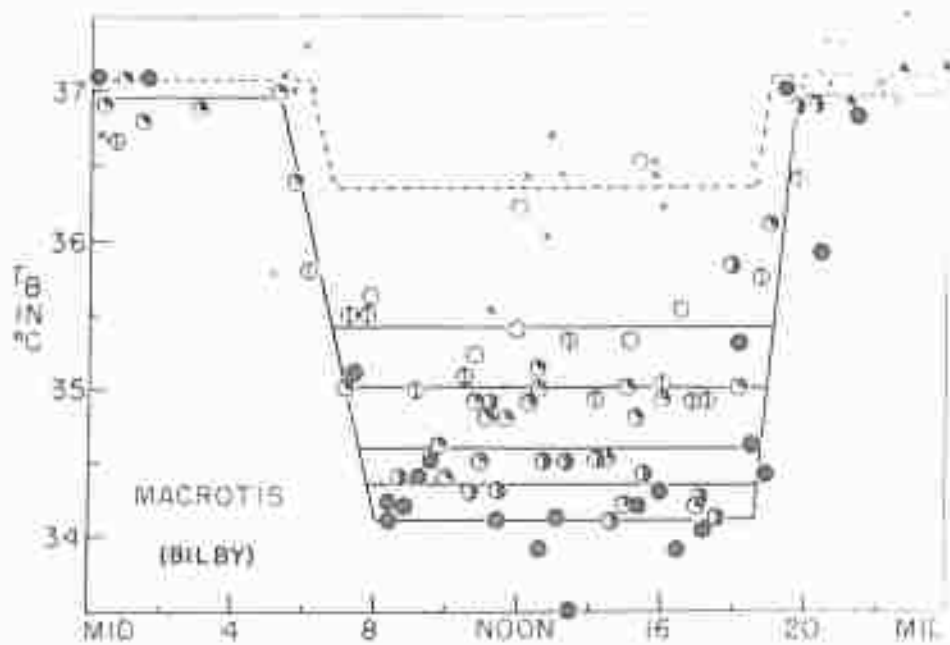
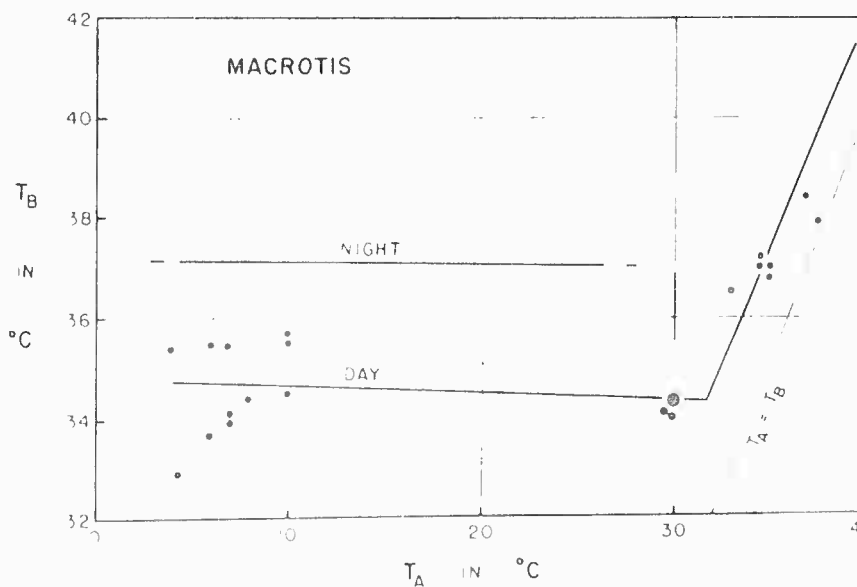

Figure 4. Daily T_B cycle in the bilby (*Macrotus lagotis*). Different symbols show successive periods of time.



ADAPTATIONS TO TROPICS AND ALTITUDES

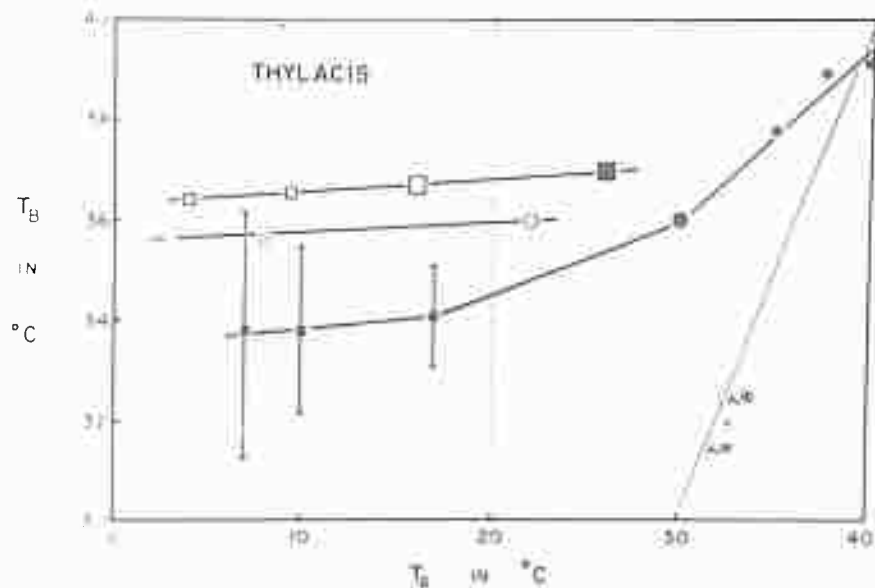

Figure 6. T_B as a function of T_A in the short-nosed bandicoot (*Thylacis obesulus*). Open symbols, winter; closed symbols, summer; circles, day; squares, night.

But the summer animals did not maintain their temperature in the daytime. So this suggests that there is some kind of adaptation of thermoregulatory control not in the metabolic capacity nor in the insulation, but in the ability to respond to a stimulus which it may not encounter.

Figure 7 describes the koala. This is a familiar sluggish marsupial (Phalangeridae) which has poor temperature regulation to cold as can be seen from the very substantial slope to the T_B curve. In this regard the koala seems quite inadequate, but since the T_B curve continues almost in a straight line across the isothermal line, it actually has quite effective regulation to heat; much better, indeed, than many of our higher mammals, such as the rodents, which cannot maintain the T_B below the T_A . There is again a considerable scatter in these points, but much of this could be eliminated by proper definitions of the conditions. This is a particular problem with a sluggish animal which adjusts only slowly to new circumstances. As one might expect, the afternoon T_A is warmer than the morning T_A . But this is a diurnal animal and so part of this slope of the T_B curve reflects the daytime activity.

The examples given thus far might tempt us to characterize the marsupials as animals with very large diurnal cycles, and even to represent a measure of thermal instability, although this is a matter of some argument. But Figure 8 shows, for contrast, a small wallaby (Macropodidae) with no daily cycle at all. Similarly, Figure 9 presents one of the larger macropods in which the diurnal cycle is again absent. But in part this effect is spurious as a representation of the animal in nature because an animal as large as the kangaroo is not able to engage in his normal activity when maintained in close captivity. If it is normally occupied with moving and feeding, higher nocturnal values are obtained. However, Figure 9 is principally of interest in illustrating or suggesting another phenomenon. The checkered circles averaged by the upper dotted curve represent T_B values that were taken during the week following a critical heat test in which the animal was exposed for 6 hours at 40° . During this exposure the T_B was not markedly elevated (only to 35.4° C), since kangaroos are excellent regulators to heat. Nevertheless, following this heat exposure, an elevated

ADAPTATIONS TO TROPICS AND ALTITUDES

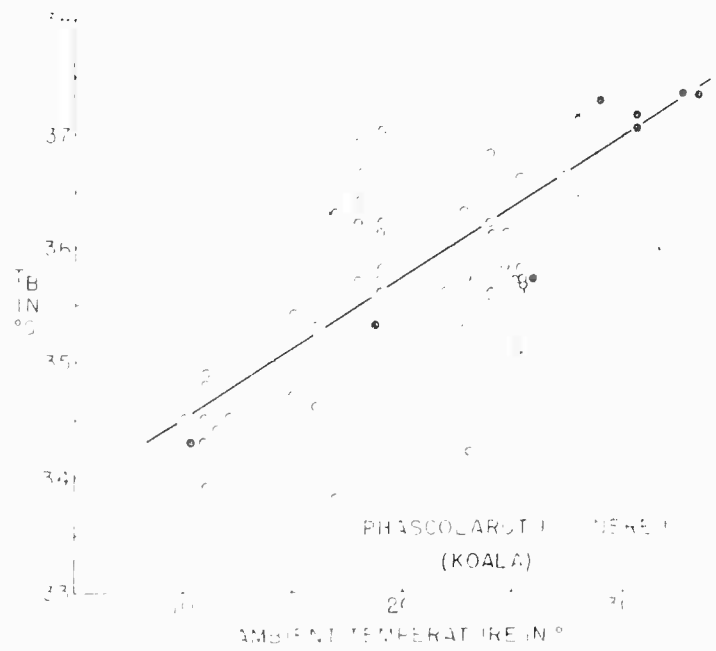

Figure 7. T_B as a function of T_A in the koala (*Phascolarctus cinereus*).

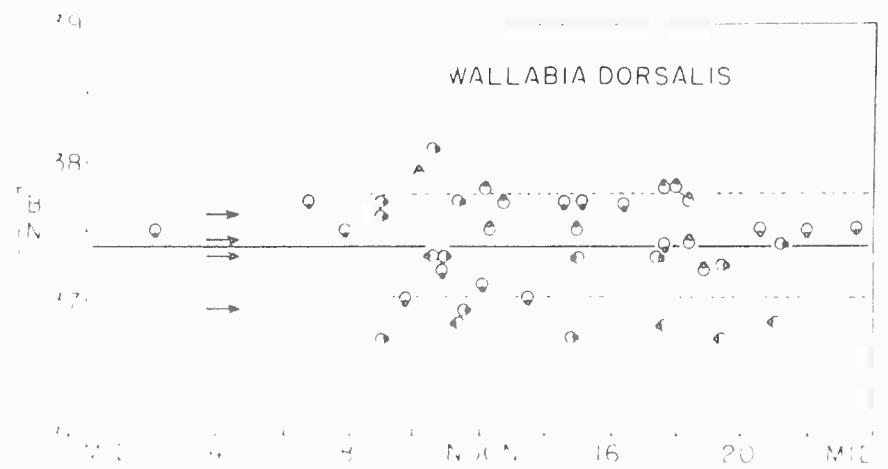

Figure 8. Daily T_B response in the black-striped wallaby (*Protemnodon dorsalis*). Individuals differentiated by symbols.

T_B was recorded, not only on the following day, but for more than a whole week thereafter. The crossed circles in Figure 9 represent the second week after that exposure with some return towards the normal level, and then finally the lined circles show the return to normal in the third week. Here, then, is a suggestion of an adaptation of T_B in response to a thermal stimulus, a response which as Scholander et al. (1950) point out is not appropriate to cold. But because a difference of only a degree or two in T_B in a hot climate may allow the elimination of evaporative cooling, it could be a very useful response to heat.

In summary, the marsupials are a primitive group which cannot be characterized by a single thermoregulatory pattern. Some show excellent regulation to cold while others are cold-sensitive. Some have very effective regulation to heat while others have none. There does seem to be some disposition towards thermal lability, although not necessarily thermal inadequacy in the group.

Chiroptera

The Chiroptera have always been of special interest because of the seasonal and daily hypothermia exhibited by those temperate forms which have been studied. However, they are essentially a tropical and subtropical group, so we should, perhaps, characterize the order in terms of the tropical representatives. It is in the tropics that they show their greatest profusion, both in numbers and in their specializations for different environmental or behavioral situations. The flying foxes, or Megachiroptera, weigh as much as a kilo and are very substantial animals. In Australia we found that one megachiropteran (*Pteropus*) regulated its temperature very well against cold, and that it had insulative properties and metabolic responses which were quite comparable to small temperate-zone mammals of the same size (Morrison, 1959). We were, therefore, interested in Brazil last year to examine a series of the microchiropteran fruit bats, largely from the Phyllostomidae.

Figure 10 shows the daily cycle for one of these genera, *Artibeus*. The cycle is substantial, but not extreme, with a range of about 3°C between the mean minimum and maximum levels.

ADAPTATIONS TO TROPICS AND ALTITUDES

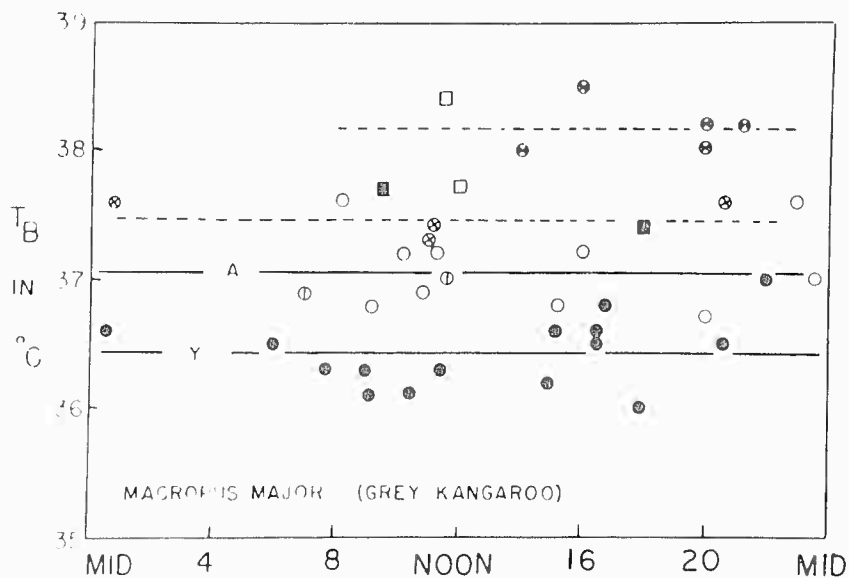

Figure 9. Daily T_B response in the grey kangaroo (*Macropus major*). Closed circles show ordinary temperature in a young animal; open circles in an adult; squares represent active animals; other symbols follow heat exposure (See text).

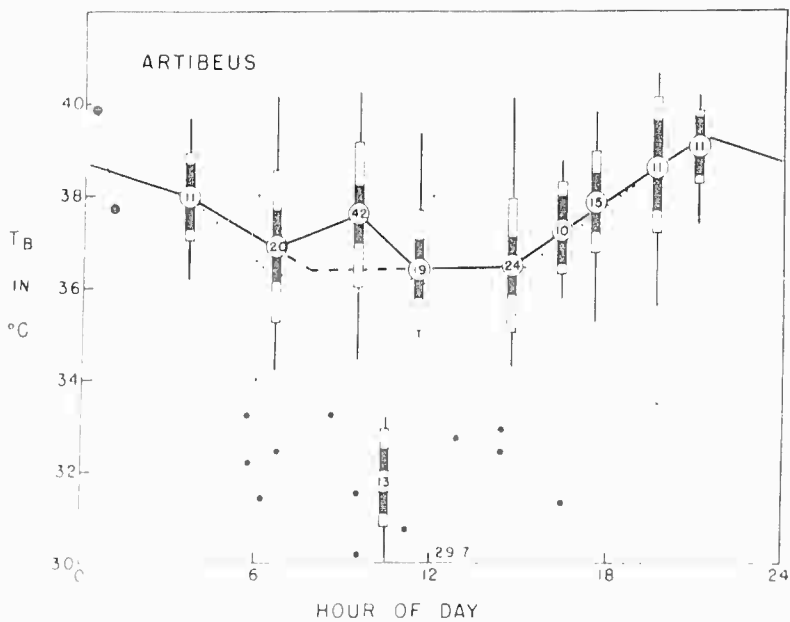

Figure 10. The daily T_B cycle in *Artibeus*. Symbols show sample size, mean value, $2 \times$ standard error, standard deviation and range.

A small scattering of points below the main body have not been included in the heavy average because they represent a distinct population, but their inclusion as shown by the dotted curve does not change the picture appreciably. Figure 11 presents the thermoregulatory response to cold in this species and shows it to be an adequate regulator since the slope is a modest one, comparable to that in many other mammals. Under heat stress, however, there is almost no regulation, the slope being little less than the value of 1.0 characteristic of a poikilotherm.

Figure 12 shows a somewhat different T_B response in a smaller species. At modest T_A values of 15-20° C, the T_B falls substantially. But when the T_A is cooled further, the animal seizes hold and regulates its temperature quite effectively. Thus, the reduced T_B did not represent a deficit in capacity or ability to regulate, since the animal regulated well at an even lower T_A . It can be considered as representing a kind of deficiency--careless thermoregulation--but there may be functional implications. This type of response may be seen in other mammals. The jumping mouse (Zapus), for example, may cool appreciably at intermediate T_A values, but regulates well at or below 0°. Again, there is no deficit in the capacity or ability to regulate, but the animal retains an option as to its use.

Figure 13 shows the daily cycle in a larger bat (Phyllostomus) which differs somewhat. The two peaks are characteristic of a crepuscular animal which feeds at dawn and dusk. Again, there are a number of points which exceed the dispersion of the bulk of the values (d 3 S. D.), and we have in addition some very low points which approach the T_A . This polydispersity (seen also in Artibeus, Fig. 10) suggests that we may be dealing with several conditions or activity levels, a situation already indicated in the insectivorous bat Miniopterus (Morrison, 1959). This suggestion appears to be confirmed in Figure 14 which shows the more complicated response of Phyllostomus to cold. Now in Figure 13 this bat could be thought of as operating under different conditions--perhaps "active," "quiet," "sleeping" and "torpid." It was ordinarily resting during the daytime but even then could become active with a higher T_B . Occasionally it showed a torpid, poikilothermic

ADAPTATIONS TO TROPICS AND ALTITUDES

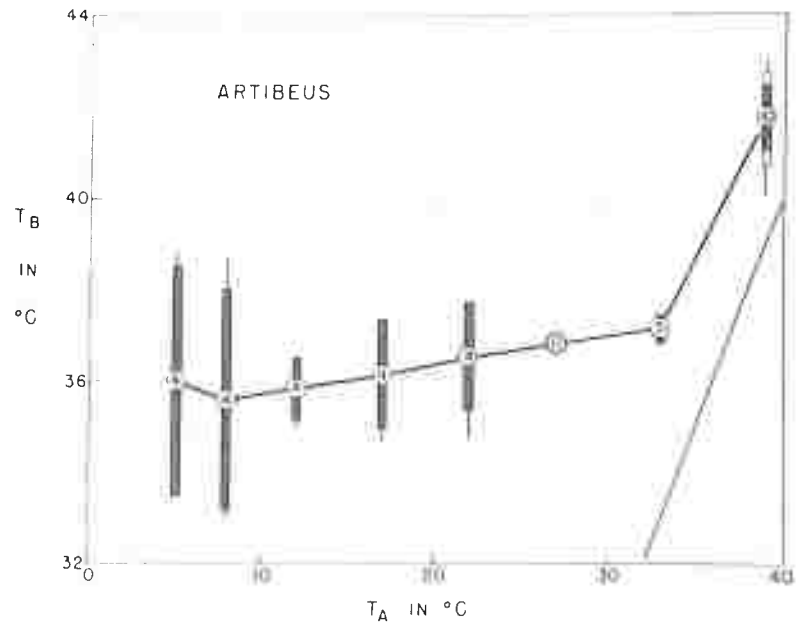

Figure 11. T_B as a function of T_A in Artibeus.

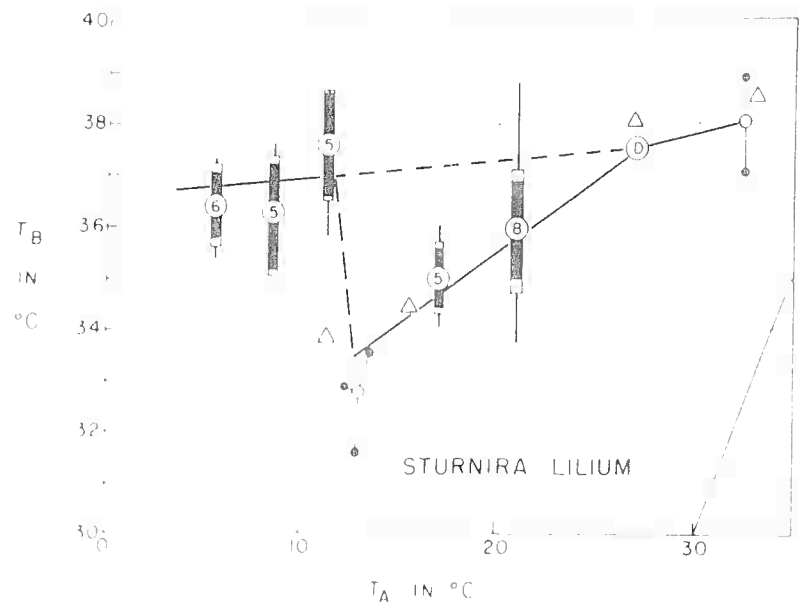

Figure 12. T_B as a function of T_A in Sturnira. Fringe's vampire bat (another species (Vampyrops) which conforms to the same pattern).

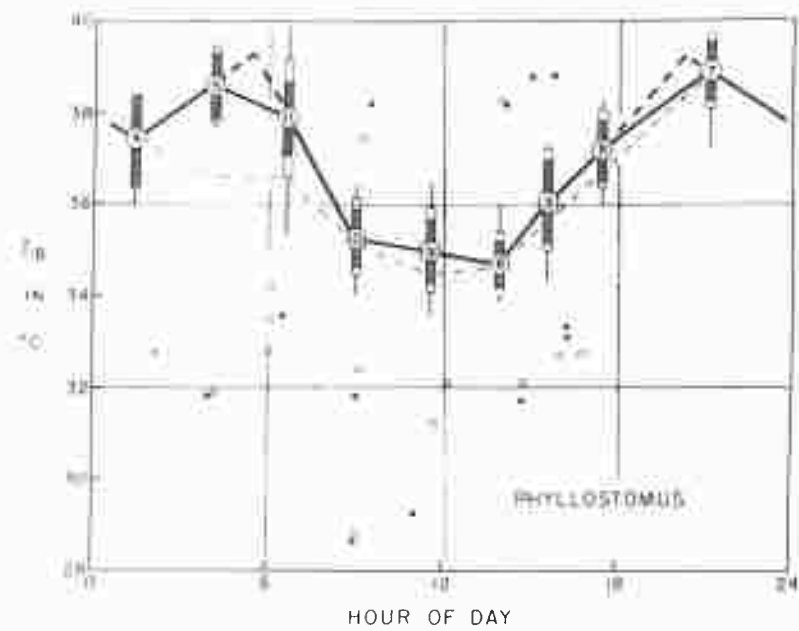

Figure 13. Daily T_B cycle in Phyllostomus.

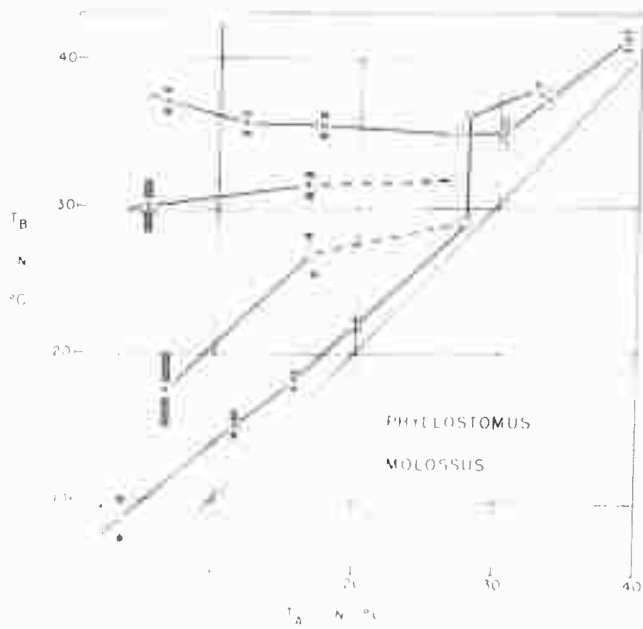

Figure 14. T_B as a function of T_A in Phyllostomus (circles) and in Molossus (squares).

ADAPTATIONS TO TROPICS AND ALTITUDES

state where the T_B approached the T_A . Also in bats here, as in *Miniopterus*, there can be an intermediate zone (sleeping?)--not poikilothermic in the ordinary sense, but just a little above 30°C where the animal can become active rather quickly, but still effect an appreciable metabolic savings. Now, the T_B groups in the cold exposed animals can be associated with these groups, although they may not be exact projections. The upper curve (Fig. 14) maintains the "resting" level and at 6°C ambient, as a more vigorous metabolic response is required, even approaches the "active" level. The intermediate curve with T_B values near 30° maintained even at 6°C ambient, gives further credence to the concept of a maintained "sleeping" level. Finally a few much lower values (lower curve) would represent torpor although not as low as the ambient level.

Figure 14 also compares *Molossus*, a tropical insectivorous bat, which uniformly became torpid when exposed to cold, although not quite to the degree expected of a similar temperate bat. Figure 15 shows the daily T_B cycle in this species (lower curve) which also closely resembles the behavior of our northern bats with elevated activity at dusk and dawn and torpor during the day. Eisentraut (1950) has discussed tropical insectivorous bats which he found to have a broader "range of activity temperature" than their temperate relatives and thus not ordinarily to enter into a state of torpor during the day. This was certainly the case in the situations where *Molossus* was collected ($T_A = 30^\circ + \text{C}$) but in the laboratory at a T_A of 26°C to 28°C it certainly entered torpor.

In Figure 15, also, the curves for the 4 frugivorous bats are compared. This set of curves presents an interesting sequence of parameters in order of decreasing animal weight. Thus, in this series, both the resting diurnal and the active nocturnal levels are increasing, the rate of change between the two activity states is decreasing, and the diurnal fall is postponed, although the nocturnal rise is fairly synchronous for the several species. The insectivorous *Molossus* fits into these sequences in all regards except weight, since it is the smallest of the lot. It is not now possible to interpret these systematic regularities, but they no doubt fit into some general pattern of thermoregulatory properties.

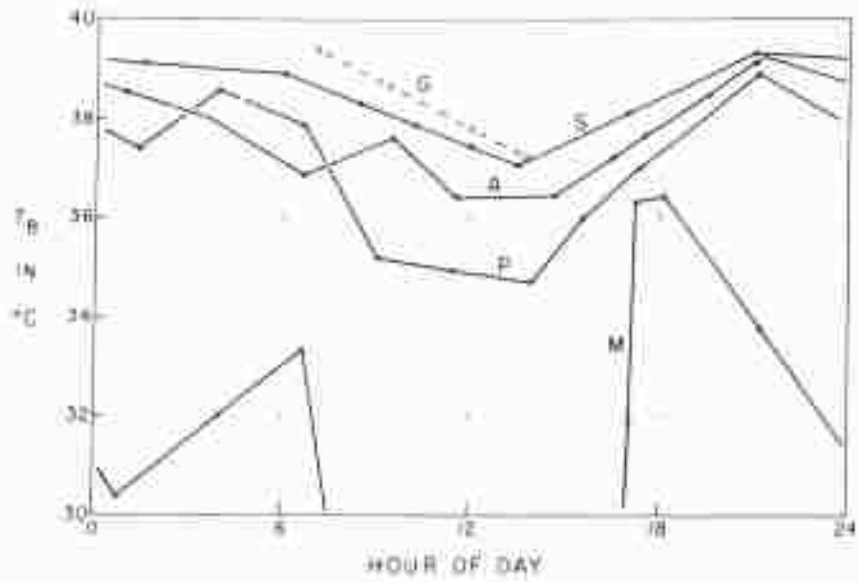

Figure 15. Summary of daily cycles in different species of bats: M, Molossus; P, Phyllostomus; A, Artibeus; S, Sturnira; G, Glossophoga.

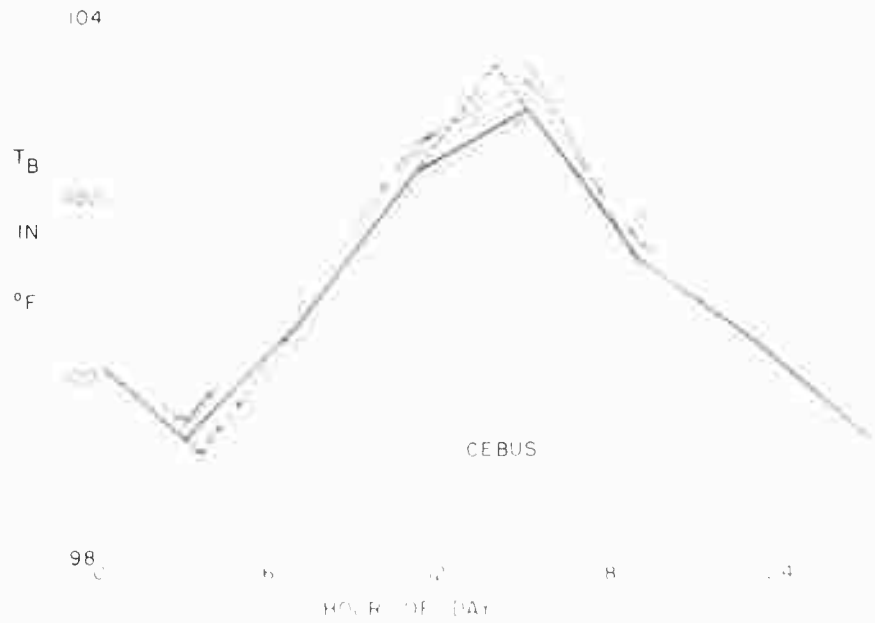

Figure 16. Daily T_B response in four species of Cebus to illustrate conformity of pattern. Points on mean curve (heavy) represent some 250 values. Data from Dr. H. L. Ratchiffe, Penrose Research Laboratory.

ADAPTATIONS TO TROPICS AND ALTITUDES

In summary, the chiroptera also show a variety of responses. Traditionally the insectivorous species are characterized by their thermolability, but the behavior of some of the frugivorous species can be indistinguishable from other mammals. However, even in the larger bats scattered values suggest a latent thermolability which may be manifested under appropriate conditions. But since this thermolability, either expressed or latent, appears to be suited to the environmental and metabolic needs, we should hesitate to describe it as a primitive feature or an inadequacy.

Primates

The last group to be considered is an advanced one, but with one exception, is even more strictly limited to the tropics. There is considerable T_B data on the Primates partly because of their use as laboratory animals, but also because of tuberculin testing, particularly at the Philadelphia Zoological Garden, (Brown, 1909; Fox, 1923). Some recent data are shown in Figure 16 which compare four species of Cebus and shows the extreme regularity of their response. The temperature cycle with an amplitude of 2.5°C is substantial, but not extreme.

Figure 17 represents a smaller primate, the marmoset (Callithrix), which shows a striking diurnal cycle with an amplitude of almost 4.0°C . Although these animals adapt well to handling and have been popular as pets for more than a century, there is almost no physiological information on them. Figure 18 considers another marmoset which is of interest as the smallest of the primates and weighs about 100 g. It, too, has a very striking cycle, although not so large as Callithrix. A unique feature is the minimum, which is very low for a primate. One may wonder if the cryptorchid condition sometimes reported in this genus (Hill, 1959) depends on this low body temperature, in accordance with the general relation between body temperature and descent of the testes as discussed by Wislocki (1933). Figure 19 shows the effect of limiting temperature measurements to six fixed times during the day as has been done in many measurements on Primates. A substantial distortion results with a plurring of the almost "square" wave form seen in Cebuella and a loss of resolution of secondary waves.

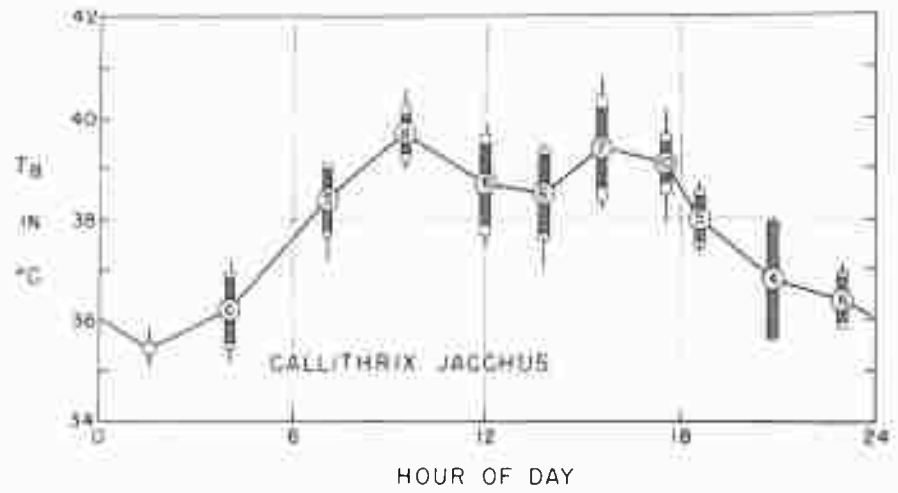

Figure 17. Daily body temperature response in the common marmoset (*Callithrix jacchus*).

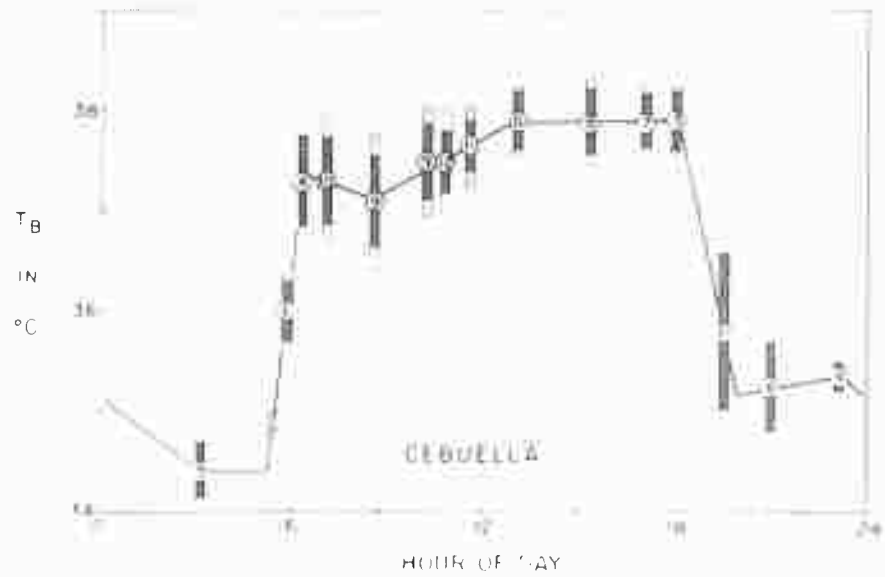

Figure 18. Daily temperature response in the pygmy marmoset (*Cebuella pygmaea*). Dashed curve shows same curve inverted and displaced by 12 hours to illustrate cycle symmetry.

ADAPTATIONS TO TROPICS AND ALTITUDES

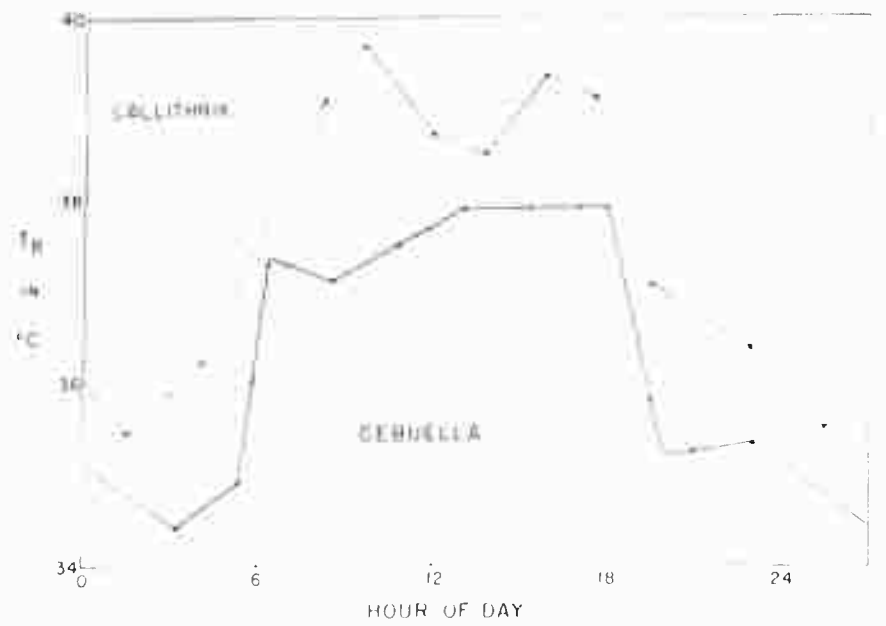

Figure 19. Distortion of the daily cycle of the use of fixed time points (03, 07, 11, 15, 19 and 23 hr.).

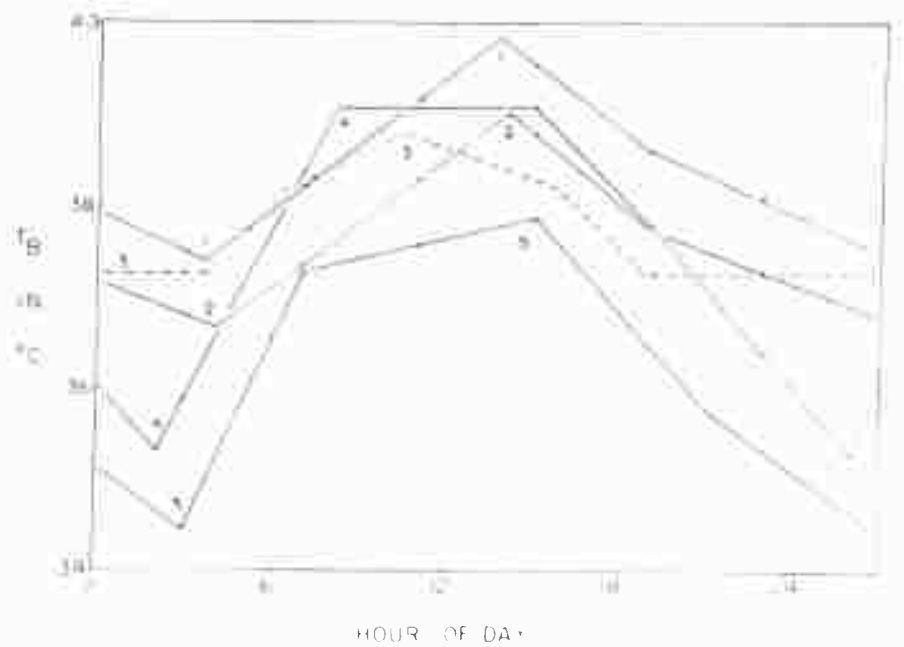

Figure 20. Comparison of daily temperature cycles in new world monkeys: 1, Lebus; 2, Ateles; 3, Aotus; 4, Callithrix; 5, Cebus. Broken curve for the nocturnal Aotus has been shifted twelve hours to allow comparison to diurnal forms.

Figure 20 compares the form of the daily cycle in several of these new world monkeys. Although at a lower level, the form of the curve in Ateles is strikingly similar to that of Cebus. By contrast, curves of the two marmosets, representing the more primitive Callithricidae, are quite distinct. Also shown in Figure 20 is the night monkey (Aotus) whose cycle, however, has been shifted by 12 hours so that it could be compared to the others. Nocturnal forms are rare among the primates and the limited amplitude of this nocturnal cycle suggests that the daily cycle may not be merely a casual concomitant of the time of activity, but be more formally impressed into the "matrix" of the animal. Thus, in this instance, the nocturnal Aotus has reversed the characteristic primate diurnal cycle, but has achieved only a limited amplitude.

Figure 21 compares another aspect of regulation in two of these species to show that while Aotus has excellent "cold" regulation, Callithrix is quite sensitive to cold. A correlation might be made with the nocturnal habit, but it is only fair to note that Aotus ranges up the Andean slopes to fairly cool situations. The response of the smallest primate (Cebuella) to cold is shown in Figure 22 and shows even less resistance to cold than the larger Callithrix. But its resistance to heat stress is distinctly superior, and at a T_A of 40°C it maintains a T_B of 40°C .

Figure 23 shows the metabolic response of Cebuella at varying T_A and presents a good example of the problem of fitting a conductance value to a thermolabile animal. If we describe our homeotherm in terms of the simplest model then the heat flow or metabolism will be proportional to the temperature differential (Scholander et al., 1950a). But, as was seen in Figure 22, the maintenance range for T_B in Cebuella was only between 15°C and 30°C , and below this we will find reduced F_B and metabolism. Accordingly, if the metabolism is plotted directly against T_A the mean curve will have too low a slope (low conductance) and will extrapolate above the T_B . To adjust for this error, the metabolism may be plotted against the temperature differential, $F_B - T_A$ (top scale in Fig. 23); or to maintain a more familiar scale, the T_A may be corrected by the amount of the F_B depression (bottom scale in Fig. 22). With this procedure, a good linear representation is obtained with extrapolation to the F_B (25°C) at the abscissa. The conductance curves

ADAPTATIONS TO TROPICS AND ALTITUDES

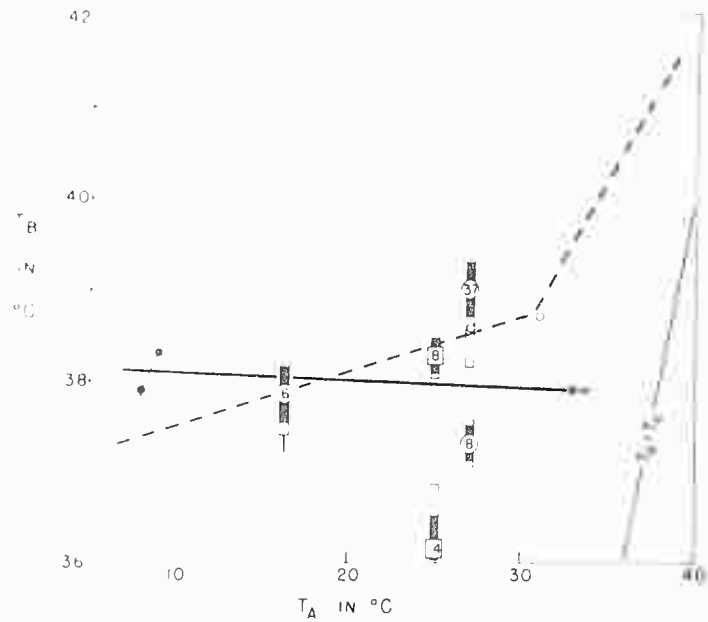

Figure 21. Body temperature as a function of ambient temperature in *Callithrix* (open symbols) and *Aotus* (closed symbols). Squares represent night values; circles are day values.

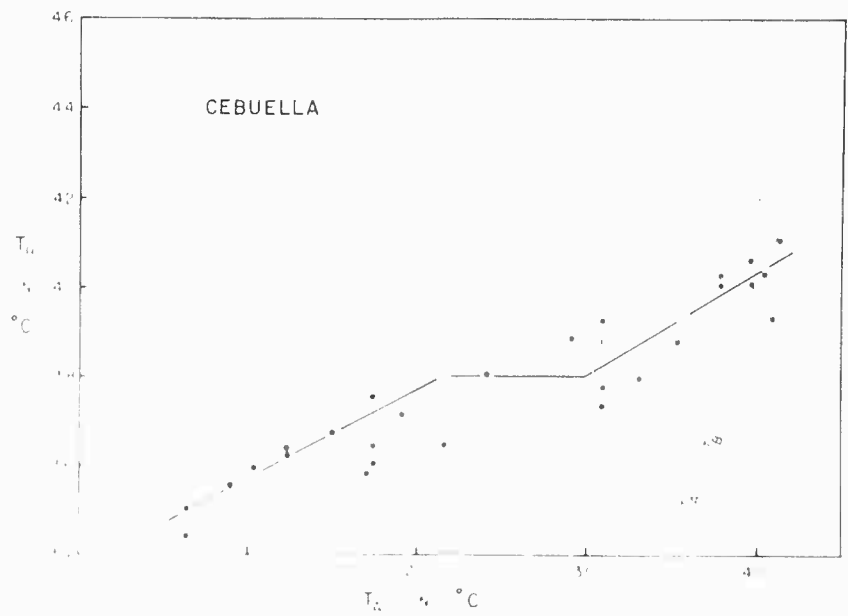

Figure 22. T_B in *Cebuella* night (open symbols) as a function of T_A (open symbols, mean of day and night).

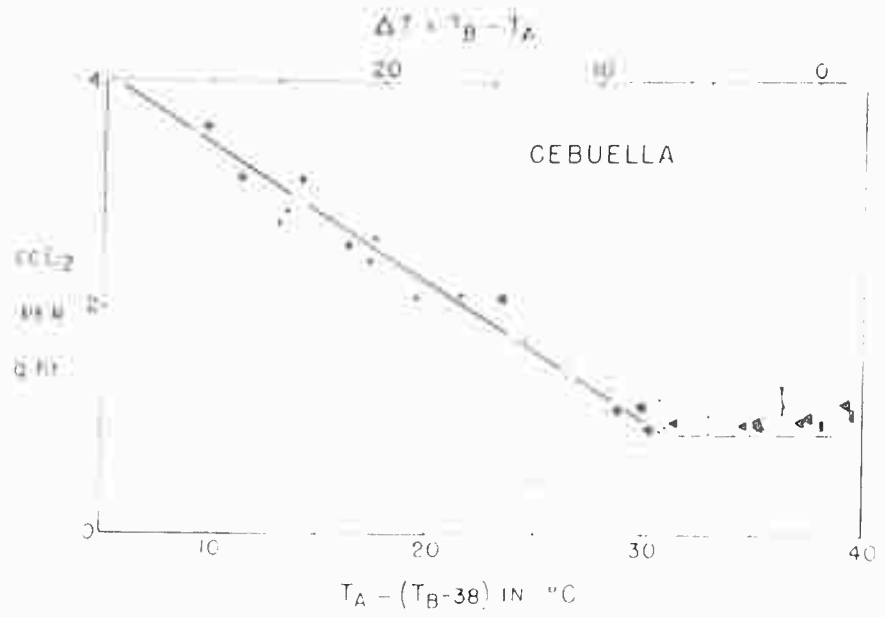

Figure 23. Metabolism as a function of ambient temperature in the pygmy marmoset. Triangles represent points adjusted for fall or rise in body temperature. Large points represent standard body temperature (38.0°). Small symbols, no temperature measurements. Light curves compare metabolic response in *Aotus* (lower) and *Callithrix* (upper).

ADAPTATIONS TO TROPICS AND ALTITUDES

for the other two primates are also compared in Figure 21. Most of the observed differences relate to the differences in size. The values for the two marmosetts lie just above the mean curve relating conductance to body weight in some temperate small mammals, $C = W^{1/2}$ (Morrison and Ryser, 1951). Aotus, by virtue of its more effective insulation, has a conductance appreciably below the mean curve.

In summary, this limited survey of thermoregulation in the primates has again shown some regularities in the daily cycles, but also some variety in this and in the response to cold. Also, to consider again the general question as to common thermoregulatory features shared by tropical mammals, there appears to be none. Certainly there is great variation in the maintained levels both diurnal and nocturnal. The response to cold and as well, to heat, appear equally variable since either or both may be present or absent. Even the criterion of inferior insulation cited by Scholander et al., (1950) does not hold for many of the smaller tropical species. Indeed, perhaps we can only characterize the tropical mammals by the complete heterogeneity of the thermoregulatory responses.

Altitude and Thermoregulation

The relation between thermoregulation and altitude appears even more tenuous than that of the tropics. It is true that if oxygen is sufficiently withheld from a mammal in the cold, its T_B will fall (Nielsen et al., 1941). But other functions and activities will be similarly impaired. Of course, to the extent that thermoregulation may require a considerably greater energy output than other functions, it will be preferentially affected--and also, as a regulation that is, perhaps, less critical than some others, it might be preferentially dispensed with as in the camel (Schmidt-Nielsen et al., 1957).

We have recently investigated the altitudinal responses of a number of Andean rodents, and the matter of their transport capacity for O_2 at varying altitudes bears on the present point since it represents a limit for energy output. Indeed, our experimental

procedure involved a cold stress (at 5° C to 10° C) to raise the metabolic level. The oxygen tension was then lowered in successive steps until a reduction in oxygen consumption was observed. This was always followed by more or less severe hypothermia depending on the duration of the experiment.

As an index of performance, we choose the pO_2 at which the metabolism was reduced to twice the basal level. Of our "low" species, the least effective was the Chilean degu (Octodon degu), a rat-sized, histricomorph rodent. The "critical" pressure for the degu was sometimes reached at an pO_2 of 110-120 mm, a reduction of only 1/4 from that at sea level. The other extreme was seen in one of the species of the high-altitude genus of Akodon, a small cricetid rodent, which could still be effective at a pO_2 of 50-60 mm, or about a third that at sea level. These were the extremes, and although animals from high altitude were on the whole much more effective than animals from sea level, a spectrum of "critical" pressures was seen. Thus, the best "low" species (Oryzomys l. longicaudatus) was more effective than several of the "high" species. The differential performance of different species from the same environment appeared to relate to general "fitness" or "athletic development." Thus, the Oryzomys was markedly the most vigorous of the low species, and it is quite reasonable that their greater metabolic potential will also be effective under the handicap of hypoxia. In a similar manner, wild guinea pigs showed significantly greater performance than their more sedentary domestic relatives taken from the same altitude.

In summary, Andean rodents from high altitude do show superior thermoregulation to cold stress when measured at low oxygen pressures. This facility appears to be unrelated to the moderate increase in cold stress on the altiplano, and relates rather to the general improvement in transport capacity by which the species adapt to the requirements of their hypoxic environment.

ADAPTATIONS TO TROPICS AND ALTITUDES

LITERATURE CITED

1. Brown, A. E. 1909. The tuberculin test in monkeys: with notes on the temperatures of mammals. *Proc. Zool. Soc., London.* :81-90.
2. Eisentraut, M. 1960. Heat regulation in primitive mammals and in tropical species. *Bull. Mus. Comp. Zool.* 124:31-43.
3. Fox, H. 1923. Disease in captive wild mammals and birds. Lippincott, Philadelphia. 665 pp.
4. Hill, W. C. O. 1957. Primates. III. Pithecoidea, Platyrrhini, Hapalidae. Edinburgh University Press.
5. Morrison, P. R. 1959. Body temperatures in some Australian mammals, I: Chiroptera, *Biol. Bull.* 116:484-497.
6. Morrison, P. R. and F. P. Ryser. 1951. Temperature and metabolism in some Wisconsin mammals. *Fed. Proc.* 10:93-94.
7. Nielsen, M., W. H. Forbes, J. W. Wilson, and D. B. Dill. 1941. The effects upon dogs of low oxygen tensions combined with low temperatures. In *Temperature, its measurement and control.* Reinhold Publ. Corp., New York. 453-461.
8. Robinson, K. W. and P. R. Morrison. 1957. The reaction to hot atmospheres of various species of Australian marsupial and placental animals. *J. Cell. and Comp. Physiol.* 49:455-478.
9. Schmidt-Nielsen, K., B. Schmidt-Nielsen, S. A. Jarnun, and T. R. Haupt. 1957. Body temperature of the camel and its relation to water economy. *Am. J. Physiol.* 188:103-112.
10. Scholander, P. F., R. Hock, R. Walters, and L. Irving. 1950. Adaptation to cold in arctic and tropical mammals and birds in relation to body temperature, insulation and metabolic rate. *Biol. Bull.* 99:259-271.

MORRISON

11. Scholander, P. F., R. J. Hock, V. Walters, F. Johnson, and L. Irving. 1950a. Heat regulation in some arctic and tropical mammals and birds. *Biol. Bull.* 99:237-258.
12. Wislocki, G. B. 1933. The location of the testes and body temperature in mammals. *Quart. Rev. Biol.* 8:385-396.

ADAPTATIONS TO TROPICS AND ALTITUDES

DISCUSSION

HUDSON: Dr. Morrison, do any of your studies correlate these tolerances of the oxygen tension within the aspect of the cardiovascular system? In the case of the house mouse you mentioned the lung and the diaphragms, so I suppose that answers part of my question.

MORRISON: Our primary objective was an evaluation of overall performance, but we examined a number of details. For example, the hemoglobin level in native mice at high altitude appears no greater than at sea level; but at both levels, hematocrits are higher in the "vigorous" species as compared to "less vigorous" species. We were not prepared to examine the factor which I suspect is the most significant, namely the capillary discharge of oxygen. Because there were only modest changes in the other factors in the chain--lung and heart size, heart and respiration rates, hemoglobin level, etc.--we are forced to conclude that there is some specialization, perhaps an increase in number, or a lengthening and contorting, of the capillaries. This would really be an optimal adaptation with minimal distortion of the normal pattern of the animal; and it would seem that this normal pattern is rather important. The house mouse does adapt, but I am sure that he is at a concomitant disadvantage in some way because it has distorted the normal mammalian form (i.e., lung fraction, heart fraction, hematocrit, etc.) which is a very constant feature. I cannot say just why the normal proportions are optimal, but I think it must be so.

Of course, you human physiologists know the problems of getting comparable material. I was impressed by this in Peru where some studies compared miners from Ororococha to other subjects from Lima. Some miners had more work capacity at 15,000 feet than the urbanites had at sea level, but clearly the development and conditioning of these subjects differed by much more than altitude.

HART: May I ask Dr. Morrison a question about the study of mice at high altitude? Were they all small mammals in your high altitude and low temperature comparison?

MORRISON

MORRISON: Yes, up to the size of a rabbit.

HART: Are these all good regulators?

MORRISON: We did not do exhaustive studies of regulation, but they seemed to regulate well.

HART: With five degrees of cooling do they always double the heat product?

MORRISON: Yes, for all the mice and rats. And incidentally, in a regime like this it is desirable to have knowledge of "where you are going," so that the cold exposure is not too prolonged. Knowing the animal and the previous experience one can approach the critical oxygen pressure quickly.

HART: Your critical temperature was quite high in all of them, I gather from this.

MORRISON: Yes, it was in relation to their size and insulation.

PROSSER: Did you find any differences between the sea level and the altitude population of the *Phylotus*?

MORRISON: By this index, yes, very definitely.

PROSSER: Is there any evidence that this is genetic?

MORRISON: Yes. We took high-altitude mice to sea level. They bred there and bore the litters which were raised to adults. The performance of these "low-raised" mice approached that of the parents. They had spent their entire lives at sea level and yet they were physiologically high-altitude mice.

JOHANSEN: In your many curves of the body temperature plotted against ambient temperature, it seems inevitable to me that the curve must bear some relation to the time of exposure to these temperatures, particularly below the critical temperature for the species.

ADAPTATIONS TO TROPICS AND ALTITUDES

MORRISON: No, these were not, in general, situations in which the body temperature was falling progressively. And, in fact, in many instances in comparing a 1- to a 2-hour or a 2- to a 4-hour exposure, the second body temperature would be higher than the first. These are essentially maintenance temperatures.

EAGAN: Did most of your measurements consist of several measurements on one animal in order to arrive at the statistics, or a single measure of the single animal?

MORRISON: Measurements of several animals; but not in all cases. This is one aspect of comparative physiology in which one cannot be too fancy in experimental design because the most important point of departure is to catch an animal. The work on the very interesting bilby represented a single individual. I do not like to work on a single individual any more than the rest of you, since it imposes limitations, but it is amazing what can be found out from a single specimen if it is husbanded.

EAGAN: Do you lump the data all together then, or do you average them for animals under the same conditions?

MORRISON: Well, we do both essentially. Usually the data are plotted with individuals identified to see whether there are different patterns of response. If none is seen, the data is then grouped and averaged without respect to the individual. In the "triple response" of the bat Phyllostomus to cold there were some definite correlations such that one individual always gave high values while two others always gave low values.

IRVING: Would it be anything more than a scheme for trying to organize some of the information in my memory to think that their very interesting elevation of the metabolic rate after its decline in moderate conditions, when the animal was further cooled resembles the response that one sees in bats and arctic ground squirrels? Do you recall that bats and arctic ground squirrels do awaken from hibernation if the body temperature is cooled below a certain level; some of the hibernators will reawaken and begin to generate heat actively. Do you think this phenomenon of yours is perhaps another phase of the same sort of thing?

MORRISON

MORRISON: Exactly. Operationally, it is just the same kind of situation. In the ground squirrel, the thermogenesis seems to act as an alarm system rather than a thermostat. If its body temperature drifts down below a fixed point, near freezing, it awakens and normal body temperature is maintained thereafter. These bats act in the same manner except that the alarm is set for 30° C to 33° C.

JOHANSEN: We saw exactly the same thing in the birchmouse, Sicista betulina, in regard to these diurnal variations. If you force on them a large negative heat load their body temperatures rise quickly.

IRVING: Or you can say the same thing then, perhaps with reference to the excellent discussion of the torpidity in birds. At the small power output it is possible that the cold metabolic animal could not tolerate very low temperatures.

MORRISON: Torpidity is incompatible with temperatures below freezing.

IRVING: Yes, they either have to reawaken or die.

MORRISON: I do not know whether they would be able to or not.

IRVING: Do you think birds can be reawakened from torpidity by excessive lowering of temperature?

MORRISON: Yes, very definitely.

IRVING: I was just wondering how you would compare them with the faculty which you have shown to be so rather widespread in mammals. I have not seen it mentioned. That is why I inquired.

MORRISON: It would be well worth looking into, particularly in some of the Californian species.

IRVING: It is always stuck in my crop that there is something that distinguishes torpidity in birds but it may be only in the way that people have looked at it.

ADAPTATIONS TO TROPICS AND ALTITUDES

HANNON: As yet, we have not had any comment on temperature regulation in the shrew. Dr. Morrison's name has long been associated with shrew metabolism. Would you care to comment on the temperature regulation of these animals?

MORRISON: I think all one can say is that temperature regulation represents an adjustment so that heat output equals heat production, and that these animals are obviously so adjusted. They do not really have a problem because of their high metabolic rate; obviously the heat flux from these animals per gram of tissue is very great.

HANNON: Have you ever studied the metabolic response of shrews when they are exposed to different temperatures? Have you ever determined the lower temperature limit for the maintenance of homeothermy?

MORRISON: You mean to exceed their limit of regulation.

HANNON: Yes.

MORRISON: Yes, we have done that, and our Sorex from Wisconsin could not take more cold than -10° to -15° depending on the wind. We used this limit to estimate the maximum metabolic rate; the value was close to that which we observed for short periods of sporadic activity. But we did not run them on a treadmill.

TEMPERATURE REGULATION IN DESERT BIRDS AND MAMMALS

Jack W. Hudson

Birds and mammals living in deserts utilize a variety of physiological, morphological, and behavioral patterns for coping with their environments. Although any pattern is adaptive when it allows a species to live and reproduce successfully in its habitat, there are examples of desert species which illustrate unique physiological mechanisms for coping with high temperatures and limited availability of water. For example, the camel (Camelus dromedarius) shows striking thermoregulatory adaptations to high temperatures and limited water supplies (Schmidt-Nielsen et al., 1957) and the kangaroo rat (Dipodomys merriami) demonstrates an excellent capacity to conserve water (Schmidt-Nielsen et al., 1948a, 1948b). However, some species of birds and mammals are able to occupy the desert habitat even though they have no unique thermoregulatory capabilities or special abilities to conserve water. For example, the wood rat (Neotoma lepida) has no unique thermoregulatory ability, and it has only a modest capacity to conserve water, a capacity approximately equivalent to that of the Norway rat (Lee, 1960). Likewise, the House Finch (Carpodacus mexicanus) and the Mourning Dove (Zenaidura macrura), which may live in the desert, have no special ability to minimize water requirements (Bartholomew and Cade, 1956; Bartholomew and MacMillen, 1960), while the Abert Towhee (Pipilo aberti) does not possess any capacity for temperature regulation absent in other passerines (Dawson, 1955). Furthermore, neither the House Finch nor the Mourning Dove is able to process salt solutions as concentrated as might be expected if its kidney were well adapted for the conservation of water (Bartholomew and Cade, 1956, 1958, 1959; Bartholomew and MacMillen, 1960).

There are many ways birds and mammals can avoid the environ-

mental extremes of high temperature and limited availability of moisture characteristic of the desert. Among these are nocturnality, fossorial habits, aestivation and hibernation, and dependence on succulent foods. The many "niches" available are correlated with a variety of successful adaptive patterns found in desert birds and mammals. It is not surprising then, that a broad spectrum of physiological abilities for coping with high temperatures and limited availability of water is found among desert inhabitants. A species possessing physiological mechanisms meriting a subjective judgment of "well adapted to the desert environment" is one which occupies a "niche" where high temperatures and a limited availability of moisture must be contended with. The converse would be true of "poorly adapted" species.

The difficulty of precisely describing the niche of a small bird or mammal has been the subject of much discussion among biologists. However, some insight into the delineation of the "niche" may be acquired by examining the physiological performance of a species in the laboratory as an index of the environmental parameters to which it is adapted. From observation of the variety of adaptive mechanisms so far found in mammals of the deserts, it is becoming apparent that no two species which have overlapping distributions have the same physiological responses and therefore probably do not occupy the same "niche." Thus competition between these desert species is minimized, a distinct advantage in an area where resources of food and water may fluctuate either seasonally or yearly.

The role of natural selection in fitting a particular species for the desert environment is difficult to assess because of the complex relationship between the phylogenetic background of the species, the "niche" occupied by a species, and the rate at which evolution can occur in response to a changing environment. However, it can be pointed out that natural selections need only act in the direction of effectiveness of solution for a particular "niche" and need not be concerned with elegance of mechanism.

While diverse behavioral and physiological adaptations for coping with the desert environment have already been found among birds and mammals living and reproducing in this region, many

ADAPTATIONS TO DESERTS

species occupying special niches remain to be studied. Recently we have examined the physiological performances of the Poor-will (Phalaenoptilus nuttallii) and three species of ground squirrels (Citellus mohavensis, Citellus tereticaudus, and Citellus leucurus). Our results illustrate some additional types of adaptations to the desert environment. The ground squirrels are fossorial and diurnal; hence, they occupy an ecologically intermediate position between the small nocturnal and large diurnal mammals. The Poor-will is crepuscular, although it may nest and roost in areas of extremely high temperatures.

The Poor-will has a basal metabolic rate one-third of that predicted from the equation: $\text{ccO}_2/\text{gm/hr} = 9.3 W^{-0.36}$. Because of its low standard metabolic rate, the lower critical temperature of the Poor-will is also very high (Fig. 1). This low metabolism minimizes the amount of metabolic heat to be dissipated, a useful adaptation when a small difference between body and ambient temperatures precludes much radiation, convection, and conduction of metabolic heat.

In order to prevent the elevation of body temperatures to lethal levels when high ambient temperatures are encountered, many birds and some mammals pant. The metabolic heat production associated with panting increases the evaporative water loss and is expensive to the water economy, a major consideration for animals of arid regions. However, unlike many birds, the Poor-will does not pant and therefore has no marked upper critical temperature. Although the thermal neutral zone begins at a rather high lower critical temperature, it is also very broad (Fig. 1) and extends at least to 44°C . At ambient temperatures above 40°C , the extensively vascularized gular area is fluttered rapidly with the mouth held open. In this way, the bird is able to dissipate its metabolic heat (in addition to dissipating heat gained from the environment when the ambient temperature exceeds the body temperature) while simultaneously keeping its level of heat production virtually unchanged. At high ambient temperatures, the amount of water expended by the Poor-will for evaporative cooling is less than that expended by other birds of comparable size (Fig. 2). The combination of a low basal metabolism and a gular flutter which does not increase the metabolic rate necessitates only a modest level of evaporative water loss in

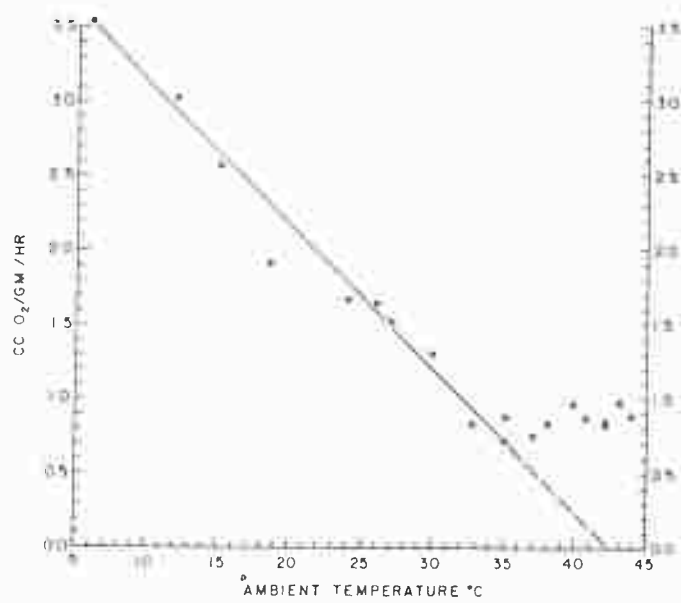

Figure 1. Oxygen consumption (corrected to STP) of a Poor-will (*Phalaenoptilus nuttalli*) plotted against ambient temperature. Each point is the minimum consumption maintained for at least 20 minutes in a post-absorptive bird. The solid line is fitted by eye and is extrapolated as the dashed line to intercept with the abscissa. This intercept indicates only an approximate conformity with Newton's Law of Cooling.

ADAPTATIONS TO DESERTS

SPECIES	WT(GMS)	T _A (°C) =	MGMS H ₂ O/GM/HR	REFERENCE
<u>Richmondia cardinalis</u>	38-48	32-33°	3.7	Dawson, 1958
<u>Pipilo aberti dumeticolus</u>	47	37-38°	7.0	Dawson, 1954
<u>Phalaenoptilus nuttallii</u>	40	42°	4.8	This study

Figure 2. Evaporative water loss in three species of birds at selected ambient temperatures. The data were estimated from the graphs of Dawson (1954, 1958).

order for this species to dissipate all of its metabolic heat and heat gained from the environment when the T_A exceeds the T_B (Fig. 3). Since at high ambient temperatures, other species of birds comparable in size with the Poor-will become hyperthermic and elevate their metabolism when panting (Dawson, 1954; Dawson and Tordoff, 1959), it is difficult to use comparisons for evaluating the reduction in evaporative water loss accruing from the Poor-will's reduced metabolism. However, it may be noted that if there is no radiation-convection-conduction of metabolic heat, as would occur in the Poor-will when the body and ambient temperatures are equal (40°C), a 40 gram bird with a metabolism one-third of normal saves 12 cc of water/day (assuming that one cc of oxygen releases 4.8 calories and 1 mgm of evaporated water dissipates 0.58 calories).

Scholander (1955) has suggested that evolutionary adaptation for temperature regulation in homeotherms has principally involved heat dissipation and that heat production has not been modified since all species, regardless of habitat, typically follow the mouse to elephant curve. Thus, arctic mammals at low ambient temperatures keep their heat dissipation minimal by virtue of good insulation and possess special means for dissipating heat during activity or at relatively high ambient temperatures. In contrast to arctic mammals and birds, animals from desert areas more frequently encounter problems of maximizing heat dissipation when there is a small difference between body and ambient temperatures. For this reason, it might be expected that at least some species, particularly those which are diurnal, would demonstrate a reduction in the level of basal metabolic heat production. The Poor-will is an example of such a species, and thus it is an exception to Scholander's generalization that metabolism is not adapted to climate. Although Scholander et al. (1950) relate the low metabolism of tropical caprimulgids to their capacity to hibernate, such a correlation does not differentiate between cause and effect. Thus, hibernation may either allow or follow a low basal metabolism. Also, considerable evidence has accumulated to suggest that the low metabolic rate of many hibernators may be attributable to the fat deposits which in themselves probably exert little effect on the overall metabolism (Bartholomew and Hudson, 1960; unpublished observations on Citellus tereticaudus and Cereacertus nana). Therefore, it is probably neces-

ADAPTATIONS TO DESERTS

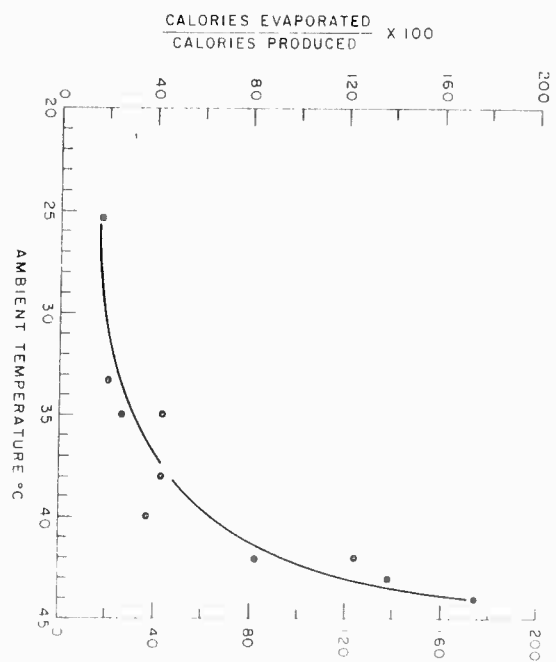

Figure 6. The relation of evaporative cooling to metabolic heat production in the Poor-will exposed to various ambient temperatures. The calculations assume that the consumption of one cc of O_2 yields 4.8 calories and that the evaporation of one mg of water requires 0.58 calories.

sary to use fat-free weights for comparing the basal metabolic rates of hibernators and non-hibernators, in order to be certain that a low metabolic rate is a phenomenon typical of hibernators.

The high lower critical temperature (35°C) in the Poor-will means that much of the time this species lives outside its thermal neutral zone. It is interesting to note that the Poor-will undergoes seasonal torpidity when food is less available and when the maintenance of a normal body temperature would be metabolically expensive (Bartholomew, Howell, and Cade, 1957). While there are other species of birds which spend much of their time outside the thermal neutral zone (Dawson and Tordoff, 1959; Scholander et al., 1950), torpor is particularly advantageous in the Poor-will, because this species represents an unusual combination of specialized morphological and behavioral adaptations for foodgetting, with its food sources subject to marked fluctuation in availability.

The low basal metabolic rate of the Poor-will is reflected in a low heart rate (Fig. 4) at thermal neutrality. Birds which are comparable in size to the Poor-will but which possess a normal metabolism (Odum, 1945) have heart rates about twice that of the Poor-will. While both heart rate and metabolism increase when the ambient temperature decreases below the lower critical temperature, the heart rate reaches its maximum level at a T_A of about 15°C , whereas the metabolism continues to increase as the T_A decreases below 15°C .

Seasonal torpidity as a thermoregulatory adaptation for low temperature is a well documented phenomenon among mammals. Although numerous natural history accounts have suggested that seasonal torpidity may also be a response to conditions of high temperatures and limited availability of food and moisture, there are only a few studies of the physiological performance of animals which utilize summer torpor or aestivation (Bartholomew and Cade, 1957; Bartholomew and Hudson, 1960; Bartholomew and MacMillen, 1961).

The ecological stimulus for aestivation is difficult to identify precisely in all of the species known to aestivate because of the

ADAPTATIONS TO DESERTS

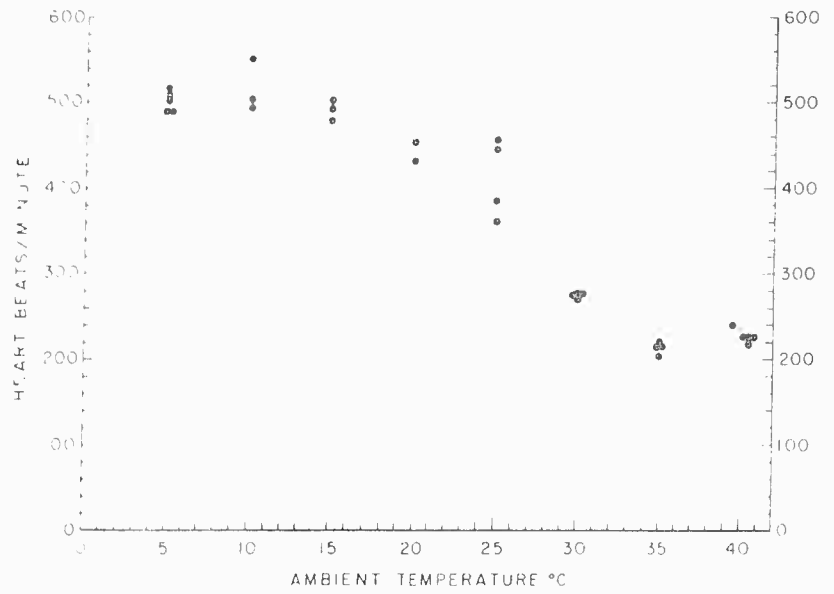

Figure 4. Heart rate of a Poor-will at different ambient temperatures. The closed circles represent the heart rate of an inactive bird following at least 10 minutes of exposure to each ambient temperature.

HUDSON

complex interrelationship between availability of food and water and the prevailing temperature. However, some of the pocket mice, which can maintain themselves on a dry diet (Perognathus longimembris, P. xanthonotus, P. formosus, P. penicillatus and P. fallax) become torpid when food is withheld (Bartholomew and Cade, 1957); furthermore, P. californicus has a daily cycle of torpidity which is related to the degree of deprivation of food (Tucker, 1961).

Adaptation of two species of ground squirrels, C. mohavensis and C. tereticaudus, to the desert environment depends in part on their capacity to become torpid. The mohave ground squirrel (Citellus mohavensis) readily becomes torpid at laboratory temperatures throughout the year, despite the continuous availability of food. Episodes of torpor are less frequent from March to August, which is their period of activity under natural conditions. When entering torpor at ambient temperatures between 22° C and 26° C, they assume the usual sleeping posture, their oxygen consumption declines rapidly, and body temperature approximates environmental temperature within 3 or 4 hours. During torpor, oxygen consumption is less than 0.2 cc/gm/hr, and the animal breathes irregularly, with marked periods of apnea. Following the onset of arousal, oxygen consumption increases 10- to 20-fold, and it usually peaks within 20 minutes. Body temperature increases more slowly, and the levels of body temperature characteristic of normal activity are usually attained in 45 to 60 minutes. Typically, rectal and oral temperatures are within 0.5° C of each other during arousal. This pattern for the onset of torpor, torpor itself, and arousal from torpor in the mohave ground squirrel is typical of the classical picture of hibernation and occurs at ambient temperatures between 10° C and 27° C (the highest measured). Under natural conditions, this species is torpid during part of the hot, dry periods and continues this pattern throughout the winter at a time when food and water are relatively scarce. Thus, the physiological mechanisms for torpidity appear to be the same during both summer and winter, although the level of body temperature may differ.

In contrast to Citellus mohavensis, C. tereticaudus kept in the laboratory throughout the year with food and water available demonstrated intermittent periods of torpidity from June to October only. Animals with body temperatures within a degree of room tempera-

ADAPTATIONS TO DESERTS

ture demonstrated the typical arousal pattern when disturbed (Fig. 5). The difference between oral and rectal temperatures during arousal was never more than 3° C, and arousal was accompanied by strong visible shivering. Animals attained a normal body temperature within 45 to 60 minutes after the onset of arousal at room temperatures. No instance of torpor was observed between November and May in a captive round-tailed ground squirrel. Furthermore, between November and May, the body temperatures of animals were much less variable and averaged higher than those found between June and October (Fig. 6). It appears from the laboratory performance of C. tereticaudus that this species may aestivate, but not hibernate. This suggestion is supported by collection records (Donald R. Dickey collection), which indicate that this species has been trapped in December, January, and February in the Coachella Valley, California. Since C. tereticaudus has been readily trapped during the summer and early fall, aestivation under natural conditions must occur on either a daily or an intermittent basis.

It is striking that aestivation is characteristic of one member of a sympatric pair of desert ground squirrels. The ranges of C. tereticaudus and C. mohavensis are overlapped by C. leucurus, but C. tereticaudus and C. mohavensis do not occur in the same area. C. leucurus neither aestivates nor hibernates, but remains active above ground at all times of the year. Thus, in the area of sympatry for these desert ground squirrels, only C. leucurus is active during the more demanding and difficult parts of the year. It seems reasonable, therefore, to postulate that between these sympatric ground squirrels competition, in the sense of utilization of a common resource which is in short supply (Birch, 1957, p. 6), perhaps is reduced, except in very poor years, because of the differences in the seasonal patterns of their metabolism.

In contrast to the diurnal ground squirrels which aestivate or to the nocturnal rodents which are fossorial, C. leucurus must cope with much of the rigor of the desert environment throughout the year. The antelope ground squirrel depends on some of the types of physiological mechanisms similar to those utilized by the Poor-will, the kangaroo rat, and the camel in adapting to desert conditions (Hudson, 1962). Like the Poor-will, the antelope ground squirrel has a broad thermal neutral zone with a relatively high lower critical

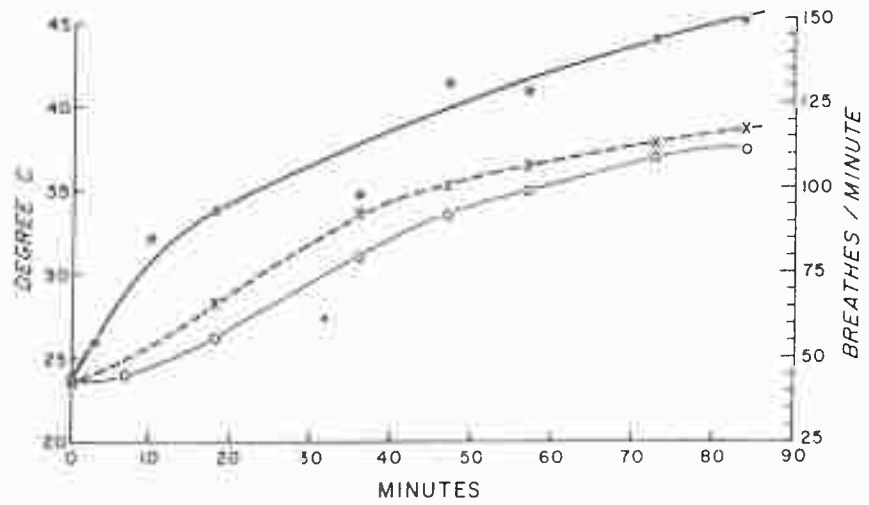

Figure 5. Body temperature and respiratory rate of a round-tailed ground squirrel (*Citellus tereticaudus*) during an arousal at room temperature (22°C to 25°C). The bottom line is the rectal body temperature; the middle line is the oral body temperature; and the top line is the respiratory rate.

ADAPTATIONS TO DESERTS

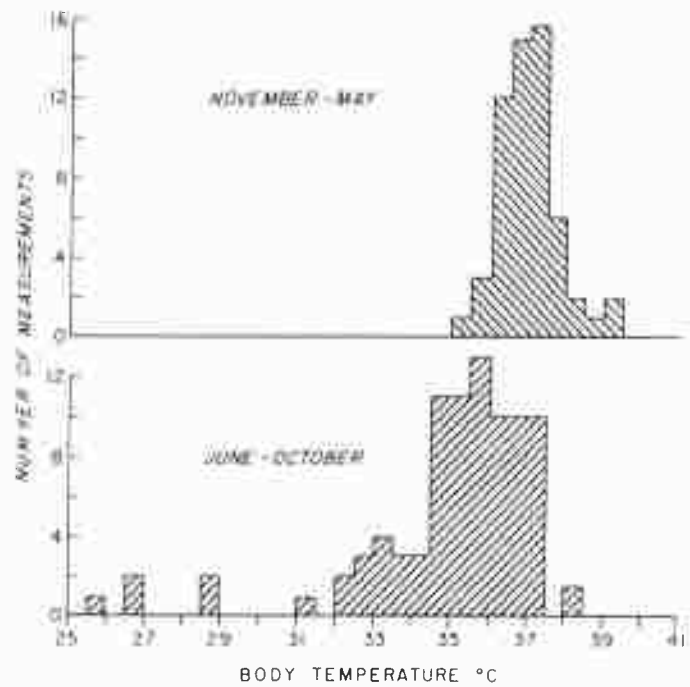

Figure 6. Body temperatures of 12 *Citellus tereticaudus* measured periodically during the year. Individual measurements were grouped into 0.5 degree intervals. The heights of the histogram represent the frequency at each interval. The separation of June to October and November to May measurements were based on the occurrence of spontaneous torpor at room temperature in the first category and its absence in the second category.

temperature and no marked upper critical temperature (Fig. 7). Unlike the Poor-will, the antelope ground squirrel has a basal metabolic rate conforming to the predicted value $\text{cc O}_2/\text{gm/hr} = 3.8 W^{-0.27}$. *C. leucurus* can tolerate ambient temperatures of 42.6°C for periods of at least 2 hours, whereas many of the nocturnal rodents of similar size cannot withstand ambient temperatures above 40°C for equivalent periods of time (Dawson, 1955; Lee, 1960; unpublished observations, Carpenter, 1961; and Tucker, 1961). The body temperature of *C. leucurus* increases linearly with ambient temperature when the ambient temperature increases from room temperature to 40°C (Fig. 8). Thus, the antelope ground squirrel depends on hyperthermia both to minimize heat gain from the environment at high ambient temperatures and to maximize loss of metabolic heat by radiation, convection, and conduction. When the difference between T_A and T_B is inadequate for dissipation of metabolic heat by radiation-convection-conduction and pulmonary evaporation of water (Fig. 9), *C. leucurus* drools copious amounts of saliva, which it actively spreads over parts of the body.

Under natural conditions, *C. leucurus* probably avoids prolonged exposures to very high ambient temperatures, which would be expensive to the water economy, by periodically returning to the cooler burrow. An animal requires only 3 minutes to reduce its body temperature from 42°C to 38°C when taken from a T_A of 42°C to 25°C . In this way, a hyperthermic animal can unload accumulated heat within the burrow and then return above ground. From this, it is apparent that behavior can be an important factor in relating the thermoregulatory capacity of this species to the prevailing environmental temperatures.

Any consideration of the problem of thermoregulation at the high ambient temperatures of the desert must take into account the availability of water and the capacity of a species to conserve water. The ability of the antelope ground squirrel to maintain a positive water balance under desert conditions is a complex interrelationship between several factors: its type of food, its level of pulmocutaneous water loss, and its capacity to conserve water incidental to excretion and defecation. While each of the above factors may be studied separately under laboratory conditions, their synthesis in relation to natural conditions is extremely dif-

ADAPTATIONS TO DESERTS

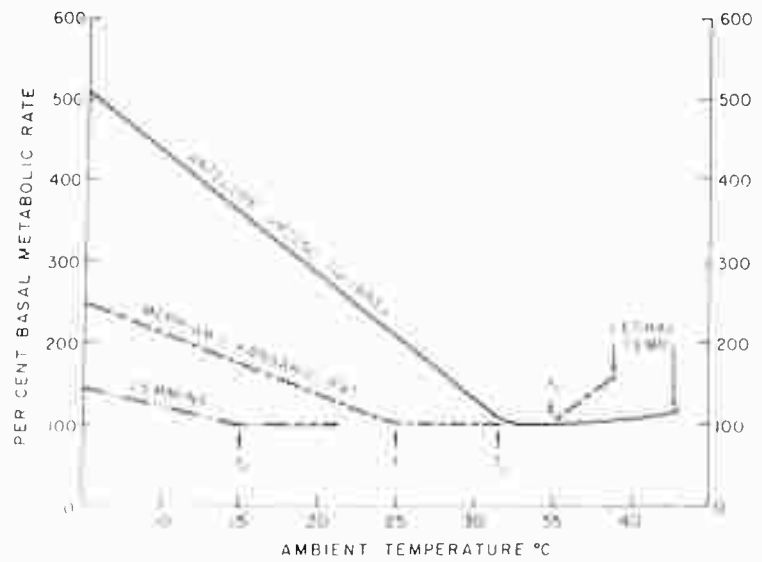

Figure 7. Metabolic rate at different ambient temperatures expressed as percentage of basal values for three species of rodents: the arctic lemming (Scholander et al., 1950), the nocturnal kangaroo rat (*Dipodomys merriami*) (unpublished observations, Carpenter, 1961), and the diurnal ground squirrel (*Citellus leucurus*) (Hudson, 1960).

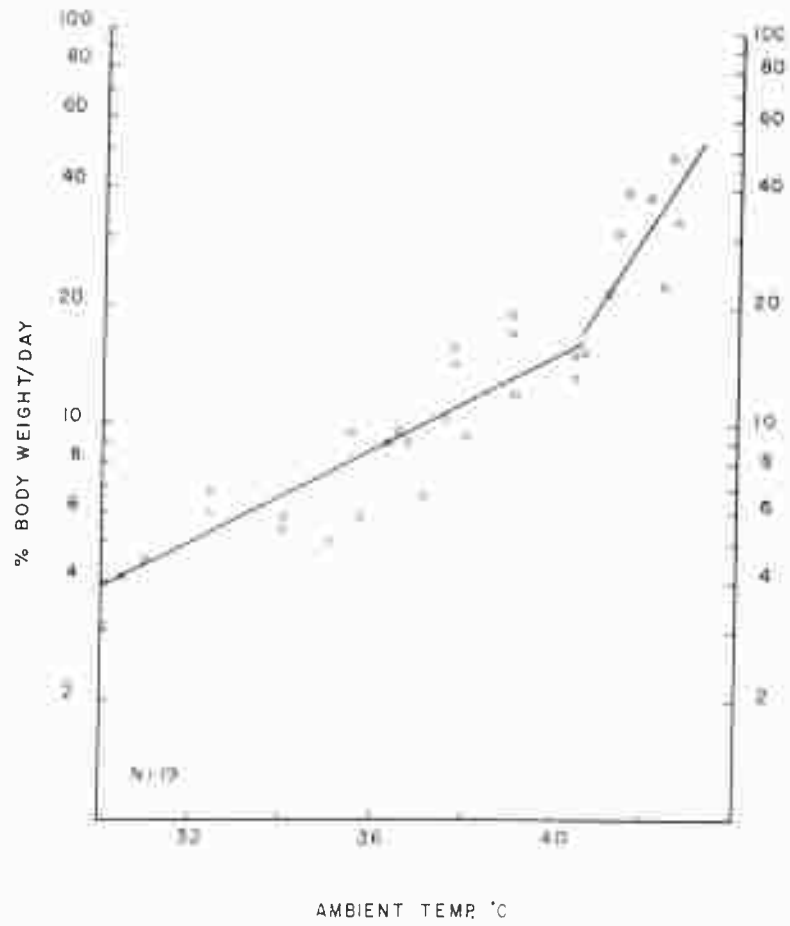

Figure 8. Evaporative water loss in 19 *Citellus leucurus* at different ambient temperatures. The line between 30°C and 40°C is described by the equation $Y = (0.04 \pm 1) (1.159)^X$. The break in the two lines denotes the onset of copious salivation.

ADAPTATIONS TO DESERTS

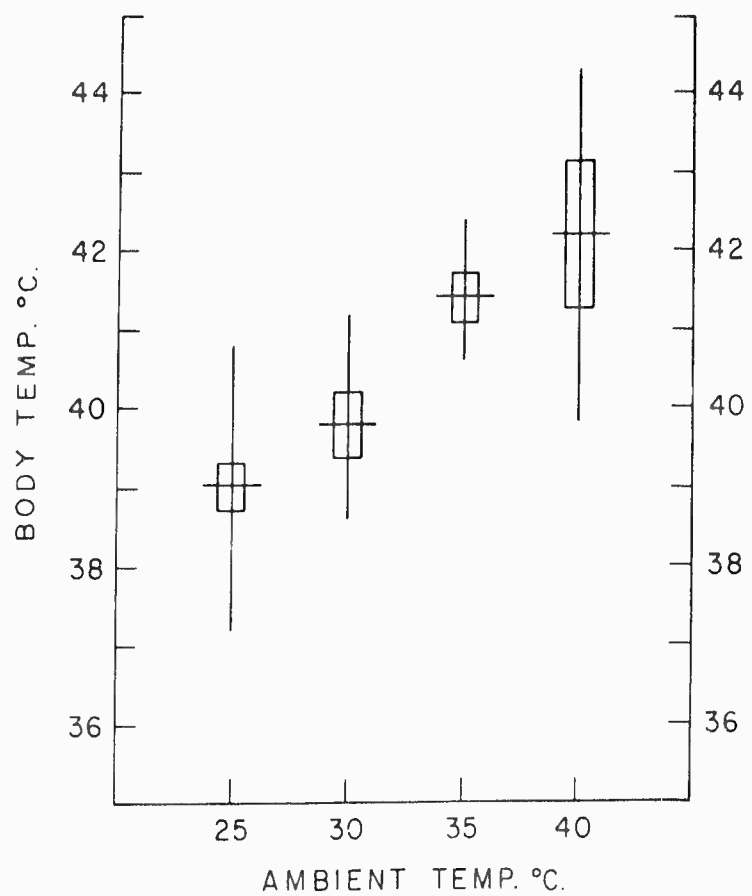

Figure 9. Body temperatures of normally active *Citellus leucurus*. The vertical lines indicate the range; the horizontal lines indicate the mean (M); the rectangles indicate the interval $M + 2s_m$ to $M - 2s_m$. The temperature below each vertical line is the ambient temperature.

ficult. However, it is possible to compare the abilities of C. leucurus and other desert rodents to minimize excretory water loss. Such a comparison serves as a basis for acquiring insight into their relative dependence on water ingestion.

The capacity of some of the heteromyids to keep urinary water loss at a minimum by the production of a very concentrated urine is well known. However, there is little information on other desert species. Direct comparison of renal concentrating capacity among species which may differ slightly in kidney performance is complicated by the variability of kidney function; this is in part related to variations in ambient temperature, diet, and fluid intake. For example, animals given water ad libitum show a correlation between the urine concentration and ambient temperatures (Fig. 10). Furthermore, because of the possibility of active transport of urea in the renal tubules (B. Schmidt-Nielsen, 1960), a high protein diet may increase solute excretion without causing an appreciable increase in excretory water loss. Single measurements of urine concentration in animals deprived of water tells little of the minimum daily water loss required for the discharge of excretory wastes.

One useful technique for comparing different species is to measure the concentration of urine produced over a 24 hour period (with comparable diets) when a species is drinking only enough water to maintain body weight. Data on average urine concentration per 24 hours while drinking a quantity of water minimal for weight maintenance are presented for C. tereticaudus (Fig. 11).

In order to compare the renal concentrating capacity of C. tereticaudus with other species, it is necessary to assume that the serum has a solute concentration of approximately 350 milliosmols and then to divide the urine concentration by this figure. On the basis of this assumption, the daily urine concentration of C. tereticaudus averages eight times the serum concentration. The average ratio of urine and serum concentrations in the kangaroo rat (D. merriami) as estimated from the data of Schmidt-Nielsen et al. (1948a, 1948b) is 10.3 when the animals are on a normal diet and 12.1 when animals are eating soybeans. The antelope ground squirrel has a urine-serum ratio of 9.7 when deprived of water (Fig. 12). Although values from all of the species are difficult to compare, it

ADAPTATIONS TO DESERTS

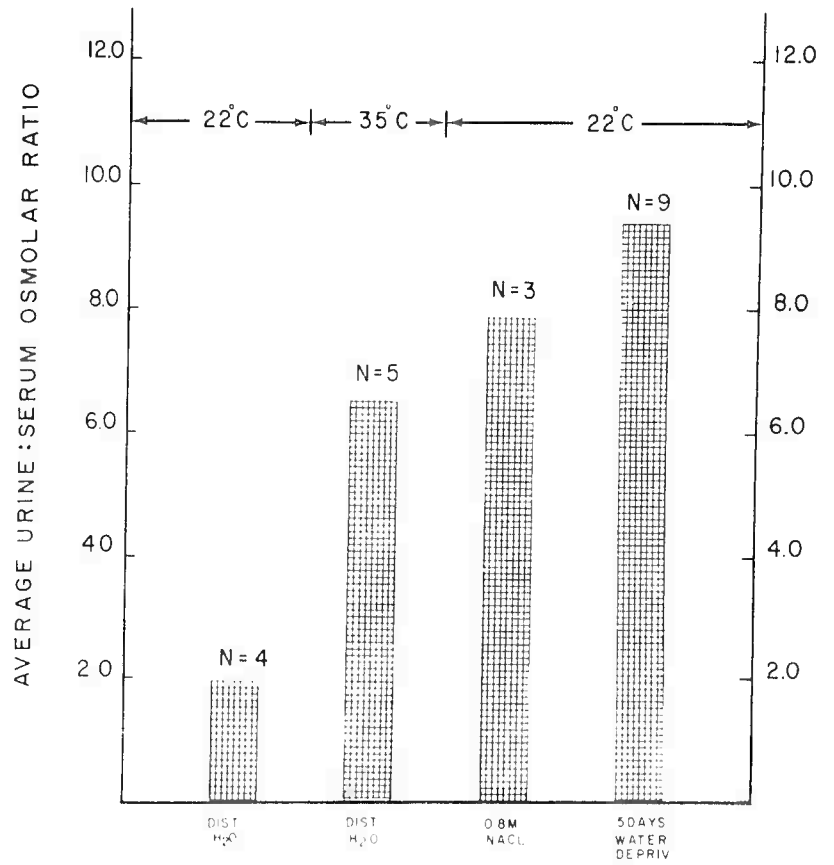

Figure 10. Ratio of urine and serum osmolar concentrations for *Citellus leucurus* subjected to the various conditions of water availability described below each rectangle. Arrows denote the ambient temperature to which animals were exposed. N indicates the number of animals.

HUDSON

Regimen	Milliosmols		N	Urine Volume (cc)		Body Weight	
	Mean	Range		Mean	Range	Mean	Range
Drinking distilled water <u>ad libitum</u> ; single samples	975	260-2800	25	---	---	194.1	132.8-251.0
Drinking minimum water; urine collected overnight	2350	1949-2802	9	1.2	0.6-1.8	170.1	142.2-225.0
Drinking minimum water; urine collected during the day; single samples	3453	2377-4012	11	---	---	170.3	111.0-233.0
Deprived of water; urine collected overnight	3093	2690-3550	6	.4	0.1-0.7	160.9	127.0-202.8
Deprived of water; urine collected during the day	2792	2324-3254	5	.2	0.1-0.3	160.9	127.0-202.8

Figure 11. Volume and concentration of urine collected from 11 *Citellus tereticaudus* maintained at room temperature. Urine was either allowed to accumulate under oil for a period of time prior to measuring its concentration, or it was measured immediately after voiding (single samples).

ADAPTATIONS TO DESERTS

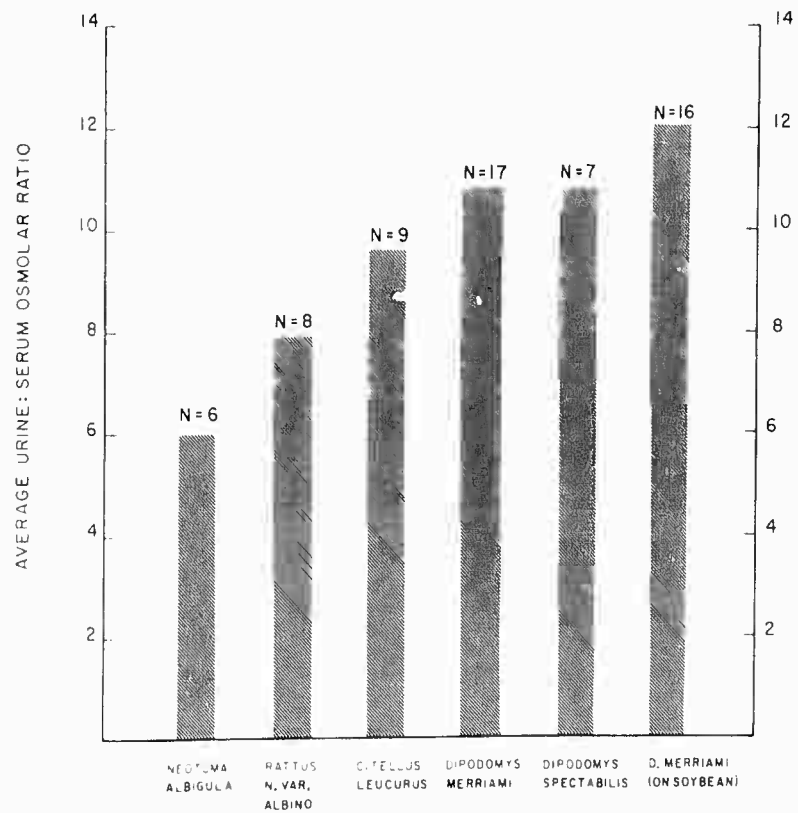

Figure 12. Renal concentrating capacity of various rodents maintained in a dry diet. The urine-serum osmolar ratios of species other than *C. leucurus* are estimated from the data of Schmidt-Nielsen et al. (1948a, 1948b).

HUDSON

appears that the ground squirrels produce a urine less concentrated than that of the kangaroo rat (D. merriami), but more concentrated than the urine of the wood rat (N. albigula). Also, the antelope ground squirrel (C. leucurus) produces a urine more concentrated than that of the round-tailed ground squirrel.

Significantly, the kangaroo rat, which is the species producing the most concentrated urine, is primarily a seed eater, and can maintain body weight on a dry diet. It is suggested that under natural conditions the daily water requirements of the diurnal ground squirrels are too large to allow dependence on the water content of a typical seed diet even if the kidney were better able to concentrate urine. Thus, while ground squirrels cannot maintain themselves on a dry diet, they have a renal concentrating capacity sufficient to balance the routine water losses with the water available in their diet of succulent foods.

SUMMARY

Birds and mammals living in the deserts utilize a variety of physiological, morphological, and behavioral patterns which may be subjectively judged as varying from "well adapted" to "poorly adapted." In all cases, the ability of a desert species to live and reproduce in its environment indicates adaptation regardless of the elegance of the mechanisms utilized. The role of natural selection is such that effectiveness of solution rather than any special mechanism is the primary criterion.

The multiplicity of adaptive mechanisms attests to the diversity of niches available, and it may turn out that no two desert species of similar distribution have identical morphological, physiological, and behavioral adaptations. While there are many species which remain to be studied, data for the Poor-will (Phalaenoptilus nuttallii) and three species of ground squirrels (Citellus leucurus, Citellus tereticaudus, and Citellus mohavensis) further demonstrate the diversity of adaptive mechanisms.

ADAPTATIONS TO DESEPTS

The Poor-will has a basal metabolism which is one-third the predicted value and is thus an exception to Scholander's generalization that metabolism is not adapted to climate. The combination of a low basal metabolism and a gular flutter which does not significantly increase metabolic heat production enables the Poor-will to dissipate all its metabolic heat at high ambient temperatures, with a minimum expenditure of water. At thermal neutrality, the low basal metabolism of the Poor-will is accompanied by a heart rate which is one-half the value found in birds of comparable size. Because of a low basal metabolism, the Poor-will also has a high lower critical temperature and may therefore spend much of its time outside the thermal neutral zone. It is significant that this species hibernates during the winter when it would require a great deal of food for maintenance of a normal body temperature.

While the stimulus for the onset of torpidity in those species of desert mammals known to aestivate is not clearly defined, limitation of food in at least two species, Perognathus longimembris and Perognathus californicus, causes periodic torpor.

Hibernation and aestivation in the mohave ground squirrel illustrate the same physiological characteristics and are differentiated only by the level of body temperature during torpor and the season in which torpidity occurs.

Under laboratory conditions, the round-tailed ground squirrel (C. tereticaudus) is intermittently torpid during the summer and fall, but does not become torpid during the winter or spring. Therefore, in terms of natural history, this species could be considered to be an aestivator and not a hibernator.

It is postulated that competition, in the sense of utilization of a common resource which is in short supply, between the sympatric desert ground squirrels is minimal because of differences in their patterns of metabolism.

The antelope ground squirrel, which is not capable of torpidity has a broad array of thermoregulatory mechanisms adaptive for its

niche. Among its adaptive patterns are: (1) tolerance of ambient temperatures up to 42.6°C for periods of 2 hours, (2) a thermal neutral zone extending from 30°C to 42.6°C without a marked upper critical temperature, (3) supplementary evaporative cooling by active spreading of a copious secretion of saliva over the body when the ambient temperature exceeds 39°C , (4) dependence on hyperthermia even at low ambient temperatures (30°C) for radiative-convective-conductive dissipation of heat, and (5) effective capacity for unloading accumulated body heat, by periodically returning to the cooler subterranean environment.

In an ecological context, problems of thermoregulation for desert birds and mammals become intimately linked to the complex interrelationship between availability of moisture, level of pulmonary water loss, and capacity for water conservation. A comparison of renal concentrating capacity among several desert rodents offers some insight into the extent of adaptation for water conservation. Ranking those species for which data are available in order of ability to concentrate urine one obtains the list: D. merriami > Citellus leucurus > C. tereticaudus > Neotoma albigula. Only D. merriami, which is primarily granivorous, is able to maintain body weight on a dry diet while the ground squirrels and wood rats depend on availability of succulent foods to satisfy their water requirements.

ADAPTATIONS TO DESERTS

LITERATURE CITED

1. Bartholomew, G. A. and T. J. Cade. 1956. Water consumption of house finches. *Condor* 58:406-412.
2. Bartholomew, G. A. and T. J. Cade. 1957. Temperature regulation, hibernation, and aestivation in the little pocket mouse, Perognathus longimembris. *J. Mamm.* 38:60-72.
3. Bartholomew, G. A. and T. J. Cade. 1958. Effects of sodium chloride on the water consumption of house finches. *Physiol. Zool.* 31:304-310.
4. Bartholomew, G. A. and T. J. Cade. 1959. Sea-water and salt utilization by savannah sparrows. *Physiol. Zool.* 32:230-238.
5. Bartholomew, G. A., T. R. Howell, and T. J. Cade. 1957. Torpidity in the White-throated swift, Anna hummingbird, and Poor-will. *Condor* 59:145-155.
6. Bartholomew, G. A. and J. W. Hudson. 1960. Aestivation in the mohave ground squirrel, Citellus mohavensis. *Bull. Mus. Comp. Zool.* 124:193-208.
7. Bartholomew, G. A. and R. E. MacMillen. 1960. The water requirements of mourning doves and their use of sea water and NaCl solutions. *Physiol. Zool.* 33:171-178.
8. Bartholomew, G. A. and R. E. MacMillen. 1961. Oxygen consumption, estivation and hibernation in the kangaroo mouse, Microdipodops pallidus. *Physiol. Zool.* 34 (in press).
9. Birch, L. C. 1957. The meanings of competition. *Am. Nat.* 91: 5-18.

HUDSON

10. Dawson, William R. 1954. Temperature regulation and water requirements of the brown and Abert towhees, Pipilo fuscus and Pipilo aberti. Univ. Calif. Pub. Zool. 59:81-124.
11. Dawson, William R. 1955. The relation of oxygen consumption to temperature in desert rodents. J. Mammal. 36:543-553.
12. Dawson, W. R. and H. B. Tordoff. 1959. Relation of oxygen consumption to temperature in the evening grosbeak. Condor 61:388-396.
13. Hudson, J. W. 1962. Role of water in the biology of the antelope ground squirrel, Citellus leucurus. Univ. Calif. Pub. Zool. (in press).
14. Lee, A. K. 1960. The adaptations to arid environments in wood rats of the genus Neotoma. Ph.D. thesis, Univ. Calif. Los Angeles Libr. 111 pp.
15. Odum, E. P. 1945. The heart rate of small birds. Science 101: 153-154.
16. Schmidt-Nielsen, B. 1960. Urea excretion, p. 82-100. In Kurt Kramer and Karl J. Ullrich, (ed.), Nierensymposium.
17. Schmidt-Nielsen, K., B. Schmidt-Nielsen, A. Brokaw, and H. Schneiderman. 1948a. Water conservation in desert rodents J. Cell. and Comp. Physiol. 32:331-360.
18. Schmidt-Nielsen, K., B. Schmidt-Nielsen, A. Brokaw, and H. Schneiderman. 1948b. Urea excretion in desert rodents exposed to high protein diets. J. Cell. and Comp. Physiol. 32: 361-379.
19. Schmidt-Nielsen, K., B. Schmidt-Nielsen, S.A. Jarnum, and T. R. Houpt. 1957. Body temperature of the camel and its relation to water economy. Am. J. Physiol. 188:103-112.

ADAPTATIONS TO DESERTS

20. Scholander, P. F. 1955. Evolution of climatic adaptation in homeotherms. *Evolution* 9:15-26.
21. Scholander, P. F., R. Hock, V. Walters, and L. Irving. 1950. Adaptation to cold in arctic and tropical mammals and birds in relation to body temperature, insulation, and basal metabolic rate. *Biol. Bull.* 99:259-271.
22. Tucker, Vance. 1961. MS.

HUDSON

DISCUSSION

VEGHTE: What is your definition of torpor; and is it reproducible?

HUDSON: Do you mean is torpor reproducible in the particular species? Can I get an animal repeatedly in torpor? Yes, it is very reproducible. We define torpor in two ways. First of all, the animal has a body temperature which is within a degree or so of the environmental temperature, and then secondly, he must be capable of spontaneously arousing so that we could not include any application of heat in order to get arousal for the animals. Incidentally this spontaneous arousal is accompanied by shivering and other classical manifestations of hibernation.

HANNON: While you are defining things, would you define "estivation"? Is there any difference between the two?

HUDSON: Well, it looks like there is not, at this point. I think a lot more work has to be done. I am not absolutely convinced that there are not some subtle differences in the physiological mechanisms of estivation and hibernation so that, as of now, estivation is the hibernation response which occurs in the summer, and, therefore, occurs at fairly high ambient temperatures.

HANNON: I am asking about torpor versus estivation. Is it the same or different?

HUDSON: Well, it seems to me this kind of thing right now is only a matter of opinion about usage of the word "torpor" rather than being based on very much factual information. I am of the opinion that estivation is a much more intermittent and brief kind of a response than hibernation. Certainly both cases illustrate torpor.

WEST: I would like to comment on the difference between results on heart rate responses of desert birds compared with the sub-arctic birds that we have been working on. We find that there is a continual linear relationship of heart rate to decreasing

ADAPTATIONS TO DESERTS

temperature as far down as we record it, and this goes to a little below 0° C. We found we cannot get any leveling off as high as we have measured it, which is about 32° C. You do not find a leveling off or thermo-neutral zone type of thing, as Dr. Hudson found in the Poor-will. We found also that at the very low temperature, the shivering was so intense that it obscured the heart rate except at very short intervals, when the heart rate would come through. I wondered how you recorded your heart rate.

HUDSON: Of course, we started off by measuring it in the thermal neutral zone and the Poor-will is probably a particularly good bird for this sort of thing, since it is quite tractable. As we get below the lower critical temperature of course the shivering begins to appear on the EKG record, but does not make it impossible to pick out the QRS complex until we begin to get down to ambient temperatures around 20° C. Now, at those temperatures, we have found that by giving the bird, and it appears to have an extremely rapid and sensitive response to this, a quick burst of heat, not enough to seriously interfere with its metabolism or its body temperature in any way, that it will immediately cut out shivering and then we can pick up a clearer EKG record. Then in a matter of minutes, of course, it starts to shiver again. I would like to counter by asking you a question, and that is: do you find any sort of a correspondence between the lower critical temperature of the heart rate and metabolism, or are all your measurements of heart rate made in the thermo-neutral zone?

WEST: I never find a thermo-neutral zone for the small birds I have studied. I never go to high enough temperatures. Unfortunately, we are so concerned with cold, we do not go much over 30° C.

HUDSON: Most of the small birds have a thermo-neutral zone or point that would be around or above 30° C.

WEST: But we get perfect linear correlation of temperature on metabolism and on heart rate, as far as we can go up and down.

HUDSON

HUDSON: This is the kind of thing that will just take more measurements of different kinds of birds.

WEST: I am interested in seeing the way your heart rate falls off at the lower temperature, then goes flat; yet the metabolism continues to fall.

HUDSON: This may be a factor that is associated with hibernation, because these are all species of birds and mammals which have the capacity to hibernate or estivate.

WEST: There must be a change in the stroke volume.

HUDSON: Yes, if I can assume you mean that it is suggestive that the stroke volume changes at the place where the heart rate levels off?

WEST: Yes.

HART: Or the utilization.

HUDSON: Yes, utilization or both.

VEGHTE: What is the duration of the burst of heat?

HUDSON: No more than a couple of minutes.

WEST: I think this is probably a safe technique; we are trying to measure heart rates in flight. We let the birds fly for a few wing beats and as soon as they hit the ground, we get the heart rate, which is extremely fast. We get it the instant that they stop flying. I know there is a small lag there but I think that this same heart rate does carry through.

HUDSON: We have also been able to pick out rates that correspond with the ones that we get where we have given them bursts of heat from records that have very intense shivering on them.

ADAPTATIONS TO DESERTS

WEST: I think that with the technique I mentioned yesterday, the power frequency distribution, we can single out the heart rate. It is so constant. It comes out as a peak in the power spectrum, no matter how much shivering is masking it on the oscillograph record.

IRVING: Do you give a Poor-will any test to find what its mental state is in a thermo-neutral zone? Is it entirely alert? Can it still do multiplication?

HUDSON: Well, he recognizes me in the thermo-neutral zone. I do not know whether that is a very good test or not.

IRVING: You do not see any noticeable signs of a mental state characterizing torpidity? That would be my main question; is that a normal resting basal rate?

HANNON: I noticed in your oxygen consumption of the Mohave ground squirrel, going in and out of torpor, that he lowered his oxygen consumption as he went into torpor. It looked like he may have lowered it more than he should. When he came out it appeared that there was an oxygen deficit. The oxygen consumption went way up.

HUDSON: This is overshoot. Yes, this is characteristic in arousing from hibernation, and I am not entirely clear on what this may all mean in terms of the internal physiology of the animal, at that time, whether there is some sort of a heat storing going on, assuming that the overshoot does not coincide with attainment of a normal body temperature. It is easier to explain in animals that restrict the development of body temperature to the fore quarters which is different from our desert ground squirrels. That is, for instance, the 13 lined ground squirrel on arousing from hibernation, typically has the anterior end of the animal developing normal body temperature first before the posterior end does, and we get no such responses. That is, we have never observed anything like this and we assume that it is related to the fact that these animals have rather high body temperatures to begin with.

HUDSON

EAGAN: Do these animals shiver as they are coming out of torpor?

HUDSON: Yes. The magnitude of the shivering tends to vary from one individual to the next, but there seems to be no difference in rate of arousal correlated with this. One gets almost the impression that there is some inefficient use of shivering going on in some individuals.

EAGAN: I think this could explain the higher metabolism. Because after all, when the animal is completely back to body temperature, then it does cease its shivering.

HUDSON: This would be the explanation for the actual heat production itself.

EAGAN: And the overshoot?

HUDSON: Yes. Shivering of course will continue on beyond the overshoot.

JOHANSEN: Have you tried to look for any vascular changes in the legs by measuring superficial temperatures?

HUDSON: No, we have not.

HANNON: Has there been any measurement of changes in blood chemistry during the course of torpor? I am getting back to this increase in oxygen consumption, and particularly, I would think of lactic acid. Is there an accumulation of lactic acid?

HUDSON: I do not know. The intubation technique that Lyman has extended promises to be a good means for finding this kind of information.*

*Lyman, Charles E. and Hudson, C. W. (1950). Cardiovascular changes in the hibernating ground sloth (*M. flaviventris*). *Bull. Mus. Comp. Zool.* 44: 1-14.

ADAPTATIONS TO DESERTS

EAGAN: I was surprised at the rapid and dramatic drop in body temperature in the species you mentioned. Was that the antelope ground squirrel?

HUDSON: When he was overheated?

EAGAN: Yes.

HUDSON: This is the antelope ground squirrel.

EAGAN: And how many minutes was that, did you say?

HUDSON: Three minutes. Of course this is a small animal.

EAGAN: Is this accomplished just through transfer through cooler air, or is it through conduction in the burrow walls?

HUDSON: Well, he was transferred into an environment where the temperature was all the same, so this is artificial, but the substrate temperature was the same as the air temperature, so conduction would be an important factor here. They show an interesting behavioral response to this; when they become overheated or become relatively warm and have the opportunity to spread out on a cooler surface, they do this by extending their legs out, lying very flat, and very close to the surface; this has also been reported by people living in the desert where they can observe these animals coming into the shaded areas or on to moist concrete.

MORRISON: If you put the animal back at 42^o C, how long does it take him to rewarm? In other words, if it took three minutes to cool, how long will the reverse process take?

HUDSON: We have not done that.

HART: Have you calculated the basal metabolic rate of the Poor-will in absolute units at the thermo-neutral zone?

HUDSON: In terms of calories?

HUDSON

HART: Yes.

HUDSON: No, I just did it on the basis of oxygen consumption.

HART: You made the point that it was very low. I was wondering if this was in relation to body size.

HUDSON: This is in relationship to body size. It is using the equation from Brody in assuming that one cc of oxygen consumed releases 4.8 Calories.

PROSSER: Does this metabolism fall below the standard curve?

HUDSON: Yes. It falls about 66% below the standard curve.

IRVING: What does torpor mean in the dictionary? Does it not mean a decline in brightness? I am still interested in the napping state. I was thinking there might be some other observation that you could make other than whether the Poor-will recognized you or not at the thermo-neutral zone.

WEST: Any way to test his reaction?

IRVING: To show whether he was alert or not, or whether he was taking a nap.

HUDSON: Well, they will feed. I know that the animal is not in a torpid state at what we call thermo-neutrality because he will feed quite regularly. Now, if you force feed him when he is torpid, he will die, apparently because of the decomposition of food in the gut under those situations, and yet when they are not torpid they can be fed successfully. Of course a torpid animal will have his eyes closed.

IRVING: But in the thermo-neutral state, they feed and eye reflexes are apparent, seem to be perfectly normal?

HUDSON: Yes, perfectly normal.

ADAPTATIONS TO DESERTS

IRVING: I think that is very rare with the metabolism diminished to one-third of the normal. But every means possible should be taken to be sure we are dealing with a more or less regular animal.

HUDSON: Well, they can fly.

IRVING: Can they take off instantly?

HUDSON: Oh, yes, if you open the cage a little too laxly, why they are gone.

KLEIBER: What saves these torpid animals from predators? Is there something which protects them?

HUDSON: As you may or may not know, a lot of the success of this laboratory in working with Poor-wills is because of human predators who have found torpid Poor-wills on their front lawn and back yard and in the library. This is the way in which we have acquired most of our Poor-wills, and I assume that predation must be rather severe.

IRVING: Maybe they do not taste good.

HUDSON: You do not know that until after you have eaten them.