

UNCLASSIFIED

AD NUMBER

AD428206

LIMITATION CHANGES

TO:

Approved for public release; distribution is unlimited.

FROM:

Distribution authorized to U.S. Gov't. agencies and their contractors;
Administrative/Operational Use; 27 JAN 1964.
Other requests shall be referred to Office of Naval Research, Arlington, VA 22203.

AUTHORITY

ONR memo dtd 7 Jul 1965

THIS PAGE IS UNCLASSIFIED

UNCLASSIFIED

AD 428206

DEFENSE DOCUMENTATION CENTER

FOR

SCIENTIFIC AND TECHNICAL INFORMATION

CAMERON STATION, ALEXANDRIA, VIRGINIA



UNCLASSIFIED

UNCLASSIFIED

NOTICE: When government or other drawings, specifications or other data are used for any purpose other than in connection with a definitely related government procurement operation, the U. S. Government thereby incurs no responsibility, nor any obligation whatsoever; and the fact that the Government may have formulated, furnished, or in any way supplied the said drawings, specifications, or other data is not to be regarded by implication or otherwise as in any manner licensing the holder or any other person or corporation, or conveying any rights or permission to manufacture, use or sell any patented invention that may in any way be related thereto.

**BEST
AVAILABLE COPY**

428206

CATALOGED BY DDC

AS AIR IND.

428206

Research
Laboratories

U

UNITED AIRCRAFT CORPORATION

A

EAST HARTFORD,
CONNECTICUT

NO OTS

DDC
RECEIVED
FEB 3, 1964
TISIA C

UNITED AIRCRAFT CORPORATION
RESEARCH LABORATORIES
EAST HARTFORD, CONN.

C-920088-2
Final Report Under
Contract Nonr-4299(00)
August 1, 1963
through
January 30, 1964

Project Title: Research on the Electrical Breakdown of Gases Under Intense Optical
Illumination

Name of Contractor: United Aircraft Corporation (Research Laboratories)

Project Code No. 3730

ARPA Order No. 306

This research is part of project DEFENDER under the joint sponsorship of the Advanced
Research Projects Agency, the Office of Naval Research, and the Department of Defense.

REPORTED BY

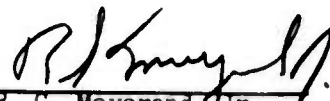
R. G. Meyerand, Jr.
Principal Scientist, Plasma Physics

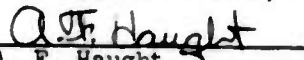
A. F. Haught
Senior Research Scientist

APPROVED BY

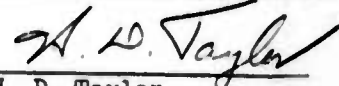
H. D. Taylor
Manager, Physics Department

NO. OF PAGES: 23

DATE: January 27, 1964

Report C-920088-2

Final Report Under Contract Nonr-4299(00)

Research on the Electrical Breakdown of Gases Under Intense Optical Illumination

TABLE OF CONTENTS

	<u>Page</u>
SUMMARY	1
RECOMMENDATIONS	1
INTRODUCTION	2
DISCUSSION OF RESEARCH PROGRAM AND RESULTS.	2
Investigation of Gas Breakdown	2
Experimental Studies	2
Physical Mechanism of Optical Frequency Breakdown.	4
Investigation of Optical Absorption	5
REFERENCES	8
LIST OF FIGURES	9

Report C-920088-2

Final Report Under Contract Nonr-4299(00)

Research on the Electrical Breakdown of Gases Under Intense Optical Illumination

ARPA Order No. 306, Project Code No. 3730

SUMMARY

A theoretical and experimental research program has been conducted on the physical mechanisms associated with the electrical breakdown of gases under the intense optical illumination from a laser. The light beam from a ruby laser was focused to a small region in the center of a test cell to ionize helium, argon, and air. Breakdown in air required the highest field strengths, the next highest were required to ionize helium, and the lowest field strengths were required for argon.

Theoretical studies have indicated that the inverse Bremsstrahlung process, involving the absorption of optical photons by free electrons during collisions with gas atoms, satisfactorily accounts for the high degree of ionization produced during the short laser pulse and, in addition, predicts the observed pressure dependence of the breakdown.

It was observed that as much as 50% of the total energy in the laser beam was absorbed in the plasma produced by breakdown and attenuations by as much as a factor of 10 were observed in the intensity of the laser beam at later times in the optical pulse. An extension of inverse Bremsstrahlung to the fully ionized case shows considerable promise as the process to account for this absorption.

RECOMMENDATIONS

The experimental results reported herein have indicated that breakdown at optical frequencies can occur in gases of interest in many systems under current development, the breakdown occurring at field strengths which can be easily achieved by optical masers. It has further been observed that a significant attenuation of the optical beam can be produced by the breakdown plasma. This latter observation has significant implications in many systems applications.

It is recommended, therefore, that additional work be undertaken to study further the physical mechanisms responsible for the observed phenomena. These studies should include, for example, a determination of the critical field strength for breakdown as a function of collision frequency at pressures as high as 10,000 psi, the effect of spot size on breakdown, and the influence of laser frequency on the critical field strengths required for breakdown.

INTRODUCTION

The interaction of extremely high intensity optical frequency electromagnetic radiation with gases is an area of physics that has been accessible to experimental investigation only with the recent development of high-powered lasers. Such studies are important to determine both the physics of the interaction of the extremely high-intensity optical radiation with matter and for the application of lasers to a number of systems. Studies of this phenomena were initiated under United Aircraft Corporation sponsorship early in 1962. Two papers reporting these corporate sponsored activities have been published; the first at the Sixth International Symposium on Ionization Phenomena in Gases, Paris, France, July 1963 (Ref. 1), and the second in Physical Review Letters, Vol. 11, No. 9, November 1963 (Ref. 2).

Under the present contract, the experimental studies of gas breakdown have been extended to include other gases, and a theory describing the breakdown mechanism has been developed. In addition, studies were conducted of the mechanisms responsible for the significant attenuation which was observed in the laser beam as it passed through the breakdown plasma.

DISCUSSION OF RESEARCH PROGRAM AND RESULTS

The theoretical and experimental investigations of the physical mechanisms associated with the electrical breakdown of gases under the intense optical illumination from a laser are described in the order the phenomena developed; that is, breakdown followed by optical absorption.

Investigations of Gas Breakdown

Experimental Studies

The Q-spoiled laser system used in the gas breakdown experiments is shown in Fig. 1. The laser element is a 1/2-inch diameter, 6-inch long ruby rod pumped by four E. G. & G. FX-47 lamps, each lamp individually powered by a 1200 μ fd. capacitor bank. Lasing action is suppressed by a polarizer and Kerr cell placed between the ruby and

the single mirror which comprise the laser cavity. With a potential applied to the Kerr cell, light from the ruby is reflected from the mirror but is not passed by the polarizer on the return path and is prevented from re-entering the ruby to stimulate further emission. The feedback mechanism for lasing is, then, only the relatively low gain path involving reflection from the flat ends of the ruby rod, and, as a result, a very large inverted population of atoms in the upper laser state must be established before any stimulated emission can occur. When the Kerr cell is suddenly discharged, a much higher gain feedback path, involving the high reflectance mirror, is available, and the large inverted population previously developed in the ruby produces a giant pulse of laser radiation. The amplified fluorescence and giant pulse produced by the Q-spoiled laser system are shown in Fig. 2. It is the giant pulse, which has a power level many orders of magnitude higher than the amplified fluorescence which is used in these experiments.

The light emitted by the laser is incident on a lens which forms one window of a cell containing the test gas; a photograph of the cell used in these experiments is shown in Fig. 3. At the focus of the lens, breakdown of the test gas by the focused laser beam is observed for suitable conditions of beam energy and gas pressure. Windows were provided in the cell to permit photomultiplier and high-speed framing camera observation of the breakdown.

A pair of electrodes placed on either side of the focus point were used to verify that electrical breakdown, that is, the production of ion pairs, was achieved. The electrical circuit associated with these electrodes is shown in Fig. 4. Both the instantaneous current and the total charge collected were measured. It was determined that approximately one-half of the total charge observed was collected over a time period of about 0.5μ sec. with the remainder being collected over a much longer time. Neither the shape of the traces nor the total charge collected, about 10^{13} electron charges, were affected by electrode potential differences from 100 volts to 200 volts, the range of the power supply used. The photomultiplier records presented in Fig. 5 show that the giant laser spike and the breakdown occur simultaneously within less than 50 nsec, the time resolution of the dual beam oscilloscope used. It is estimated that the initial breakdown occurred in a volume of 10^{-4} cm^3 . The charge collection experiments were carried out with argon at atmospheric pressure and, over the 10^{-4} cm^3 volume of the breakdown region, the 10^{13} electron charges correspond to a degree of ionization of approximately 3×10^{-3} .

Studies of gas breakdown involved first evacuating the high pressure test cell to pressures to the order of 10^{-6} mm Hg. Then the gas under test was introduced and the intensity of the laser beam was increased until breakdown occurred in the test gas. The test pressure was then changed and the experiment repeated. In the experiments dealing with breakdown in air particular care was exercised to use air free from water vapor and oil, and to frequently purge the system so that any products of the breakdown would not be present in succeeding runs. The experimentally determined field strengths required for breakdown with helium, argon, and air as the

test gas are shown in Fig. 6.

The higher optical field strengths required for breakdown of air suggest different effects may be present than in the case of the rare gases. Since the collision frequency of electrons in air is roughly comparable to argon and the ionization potentials are of the same magnitude it might be expected that breakdown of air would occur at roughly the same field strength as that for argon. However, it was determined that field strengths higher than those required for helium, even with its much lower collision frequency and higher ionization potential, are necessary to ionize air. It is believed that these higher field strengths are a result of the molecular form of the oxygen and nitrogen in air. The electrons can participate in inelastic collisions with the molecules of the gas resulting in the excitation of molecular levels. This process, which is not present in the rare gases, could be the principal energy loss mechanism of the electrons in air and it is suggested that it could well be the dominant process influencing the field strength required to ionize air.

Electron attachment to oxygen atoms is an additional process which could provide a significant loss during the breakdown and prohibit build-up of the breakdown cascade. However, the high photon flux from the laser can lead to photodetachment of the electrons attached to O^- since the binding energy of O^- is 1.46 volts, less than the 1.7 volt photon energy. Indeed, rough calculations show that photodetachment can remove all of the electrons bound to oxygen atoms, and electron attachment is apparently not an important loss mechanism in the optical frequency breakdown of air.

Physical Mechanism of Optical Frequency Breakdown

On the basis of the arguments presented in Refs. 1 and 2, none of the processes - direct electric field stripping of electrons from atoms, multiple photon absorption, Compton scattering, or conventional microwave breakdown theory - can satisfactorily account for the high degree of ionization produced during the short laser pulse. Present calculations show, however, that inverse Bremsstrahlung, first considered as a breakdown mechanism in Ref. 1 can account for the ionization observed in the optical frequency breakdown experiments. Theoretical studies of the inverse Bremsstrahlung absorption cross-section of an electron have been made for the case of electron-ion collisions and at low energies the cross-section has the form:³

$$\sigma(\nu) = \left(\frac{2e^6}{3\sqrt{3} m^2 \hbar c} \right) \frac{NZ^2}{v\nu^3}$$

The cross-section for absorption of photons of frequency, ν , varies directly as the ion density, N , and as the square of the ion charge, Z , and inversely with the electron velocity, v , and the cube of the optical radiation frequency. Free-free absorption during electron-neutral collisions, important in the present experiments,

has received little attention. However, the calculations which have been made of this process (Refs. 4 and 5) indicate that for absorption of radiation by electron-neutral collisions in air the neutral atom may be considered to have an effective charge of 0.3 resulting in a cross-section about a factor of ten smaller than that for a similar electron-ion collision.

Thus for electrons in an atmospheric pressure gas, the inverse Bremsstrahlung absorption cross-section is 10^{-19} cm² under the conditions of the present experiments. Using this value, enough energy is absorbed by the gas to produce 10^{16} ion pairs during the 1 joule, 30 nsec laser pulse, an ionization more than sufficient to account for the 10^{13} ion pairs observed experimentally. (Recombination losses are undoubtedly present and the figure, 10^{13} ion pairs, should be regarded as only a lower bound on the ionization produced.) The inverse Bremsstrahlung process also predicts the observed pressure dependence of the breakdown. The absorption cross-section, as noted above, increases linearly with the atom density. Thus the threshold for breakdown should decrease inversely with pressure which is consistent with the results obtained experimentally.

Investigation of Optical Absorption

In the course of the gas breakdown experiments, a large anomalous attenuation of the laser beam was observed, and investigations were undertaken of the attenuation of the laser beam as it passed through the breakdown plasma. A schematic diagram of the apparatus used in these absorption studies is shown in Fig. 7. A photomultiplier was used to monitor the laser radiation after it passed through the plasma produced by the laser beam at the focus position of the lens. With the photomultiplier filtered so that it is sensitive only to the 6943 Å ruby laser light, it was observed that when breakdown occurs the laser light was severely attenuated. A double exposure of the laser radiation recorded by the photomultiplier is shown in Fig. 8. The larger amplitude trace represents the ruby radiation received by the photomultiplier when breakdown did not occur, and the smaller trace is the attenuated signal received when breakdown occurred.

The attenuation of the transmitted laser beam when breakdown occurs could result from several causes: maloperation of the laser itself when breakdown occurs; scattering of the radiation out of the solid angle received by the photomultiplier; or the inverse Bremsstrahlung absorption which has been hypothesized to explain the appearance of the breakdown itself. Each of these possible causes are discussed in the following paragraphs.

To establish that the appearance of breakdown was not the result of a different manner of operation of the laser or that the breakdown luminosity did not affect the operation of the laser, the ruby output was observed with a second photomultiplier positioned at the opposite end of the laser. The output of this photomultiplier is characteristic of the operation of the laser and remained unchanged whether or not

no breakdown, or breakdown with its resulting attenuated signal, was observed by the first photomultiplier. Thus the attenuation is not the result of a maloperation of the laser. This point was further confirmed by placing a neutral density filter between the laser and the focusing lens thereby reducing the laser intensity to the point that breakdown was not observed. When this filter was moved to a position just in front of the photomultiplier, the filtering of the laser beam is, of course, unchanged, and the same signal should be observed by the photomultiplier. However, with the filter now located after the breakdown position (and just in front of the photomultiplier) the laser intensity at the focus of the lens is sufficient for breakdown, and experimentally the signal observed by the photomultiplier is attenuated as shown in Fig. 8. This simple experiment shows that the attenuation of the laser beam can be uniquely identified with the occurrence of the breakdown and is not the result of an altered operation of the laser itself.

The energy of the laser beam is approximately one joule, and as shown in Fig. 8 the breakdown results in an attenuation of this beam by a factor of about two; that is, about one-half joule of energy has been removed from the beam as a result of the breakdown. Even if the gas in the breakdown volume (air at atmospheric pressure in this series of absorption experiments) were fully ionized by the laser beam, the ionization would require only 3×10^{-3} joules. Thus the ionization energy does not account for the energy loss which, as shown in Fig. 8, results in an attenuation of the beam intensity by as much as a factor of 10 in the later portions of the optical pulse.

To determine if the attenuation of the transmitted laser energy is due to a scattering of the beam by the plasma, for example through the stimulated or coherent effects considered in Ref. 6, a series of photomultiplier measurements were made covering the entire solid angle around the breakdown region. It was observed that a slight enhancement of the scattering of the light beam did occur when breakdown took place. However, integrating over the entire 4π solid angle, the increased scattering is negligible compared with the one-half joule removed from the transmitted beam.

If the energy lost from the laser beam were absorbed in the gas, this absorption should be observed as a temperature or pressure rise in the gas. To test this hypothesis, the breakdown was produced within a small closed cell containing a sensitive pressure transducer as shown in Fig. 9. When breakdown did not occur, no pressure change within the cell was observed. However, when breakdown did occur, a 2 psi pressure increase was measured. This pressure increase in a cell volume of 23 cm^3 is equal to approximately one-third joule and is roughly the amount of energy (one-half joule) that was previously observed to be removed from the laser beam. This experiment established unambiguously that the energy in the optical beam was absorbed as it passed through the breakdown plasma.

To remove any connection between the formation of the breakdown plasma by the focused laser beam and the attenuation of the laser beam itself, a series of experiments were performed using as the absorbing plasma a xenon flashlamp driven by an energy storage capacitor. The experimental configuration for these experiments is shown in Fig. 10. It is important to note that in these experiments a focusing lens is not present. The unfocused laser beam (unfocused so that it will not cause breakdown) is directed through the xenon flashlamp, and the attenuation of the beam is observed for different values of the flashlamp voltage. The attenuation obtained is graphed in Fig. 11 as a function of the flashlamp voltage. On the basis of the experimental results previously described, laser maloperation or scattering has been eliminated as being responsible for the attenuation of the laser beam. Inverse Bremsstrahlung which has been hypothesized to explain the breakdown discussed earlier may, as an absorption mechanism, produce the attenuation observed in both the xenon flashlamp and the gas breakdown experiments. The relationship for the inverse Bremsstrahlung cross-section in the fully ionized case is given in Ref. 3. Since the percentage of ionization in the flashlamp is quite high, it is felt that the application of the fully ionized cross-section should be valid. For an electron density of 5×10^{18} per cm^3 , i.e., an assumed ionization of 75 per cent, the calculation gives a mean free path for the 6943 \AA ruby radiation of 1.8 cm or a total attenuation over the 6 cm path in the xenon plasma of 3×10^{-2} . This result is the same order of magnitude as the observed attenuation for a flashlamp voltage of 4500 V where 75 per cent or greater ionization would be expected. Therefore, the energy absorbed in the highly ionized case can be attributed to inverse Bremsstrahlung and lends additional support to the original hypothesis that inverse Bremsstrahlung is the mechanism operating in the formation of the breakdown.

An additional series of experiments was conducted to determine the effect of the gas pressure on optical energy absorption during breakdown. Helium was introduced into the test cell at pressures up to 1300 psi and the radiation transmitted through the breakdown plasma was observed by a photomultiplier placed at the exit viewing port. The data for these experiments are shown in Fig. 12. It is noted that the amount of energy removed from the pulse increases with increasing gas pressure. The increase in energy absorption with gas pressure indicates an increased rate of production of ionization resulting in the production of a high density plasma earlier in the breakdown pulse, and consequent energy absorption for a greater period of time. It is believed that the increased production can be explained by the higher gas pressure and correspondingly greater electron-atom collision frequency.

REFERENCES

1. "Gas Breakdown at Optical Frequencies," by R. G. Meyerand, Jr. and A. F. Haught, presented at the Sixth International Symposium on Ionization Phenomena in Gases, Paris, France, July 1963.
2. R. G. Meyerand, Jr. and A. F. Haught, *Physical Review Letters*, 11, 401, (1963).
3. H. A. Bethe and E. E. Salpeter, Quantum Mechanics of One- and Two-Electron Atoms (Academic Press Inc., New York, N.Y., 1957).
4. R. G. Breene, Jr. and M. C. Nardone, *Journal of the Optical Society of America* 50, 11, 1111-14 (1960).
5. T. Wentink, Jr., et. al., *Journal of Applied Physics* 29, 742 (1958).
6. "Enhanced Radiation from Ionized Gases," by H. Dreicer, presented at the Sixth International Symposium on Ionization Phenomena in Gases, Paris, France, July 1963.

LIST OF FIGURES

- Fig. 1 Q-Spoiled Laser System
- Fig. 2 Laser Waveform
- Fig. 3 High Pressure Test Cell
- Fig. 4 Charge Production in Breakdown
- Fig. 5 Time Sequence of Giant Pulse, Charge and Luminosity
- Fig. 6 Breakdown Field Strength as a Function of Pressure
- Fig. 7 Attenuation by Breakdown Plasma
- Fig. 8 Attenuation of Laser Beam
- Fig. 9 Breakdown in Closed Volume
- Fig. 10 Attenuation by Flashlamp Plasma
- Fig. 11 Attenuation of Ruby Laser Beam by Flashlamp Plasma
- Fig. 12 Optical Energy Absorption

Q - SPOILED LASER SYSTEM

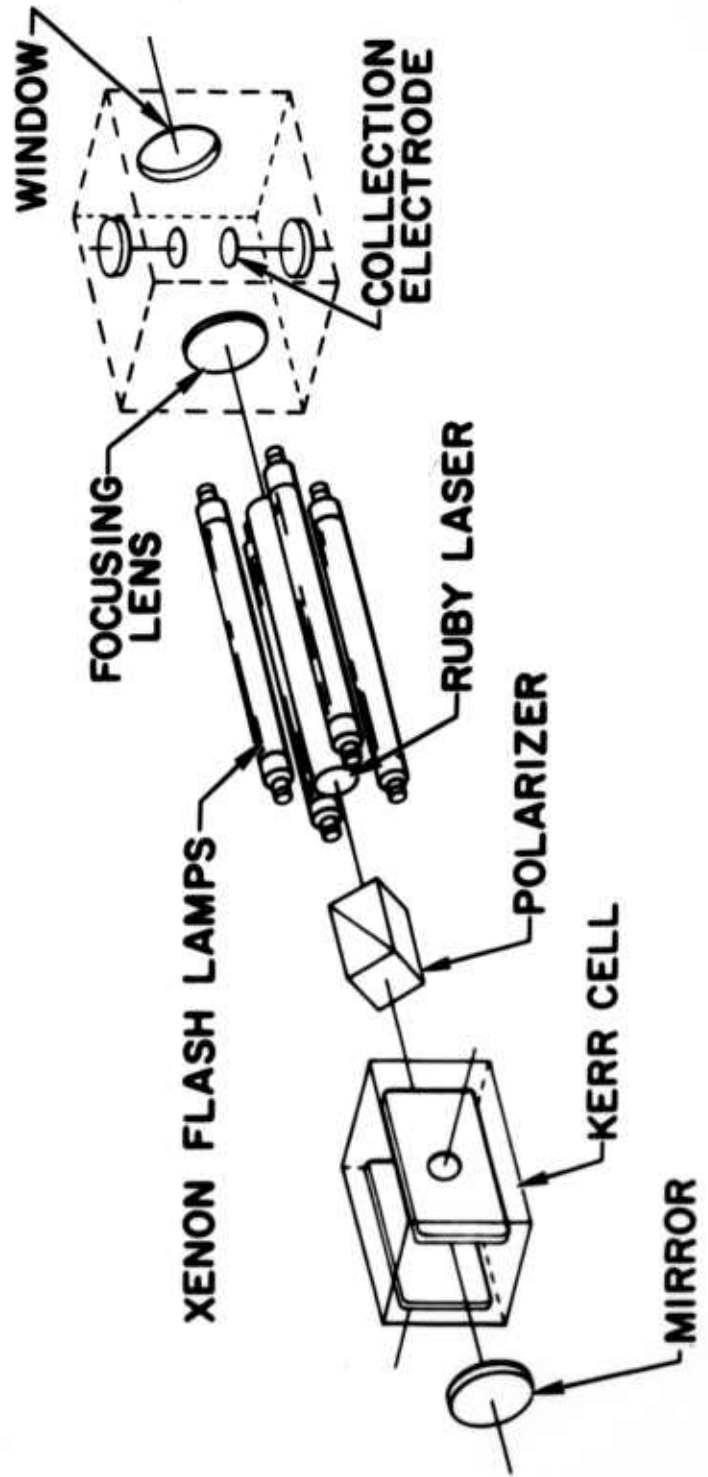

LASER WAVEFORM

KERR CELL TRIGGER

RUBY OUTPUT

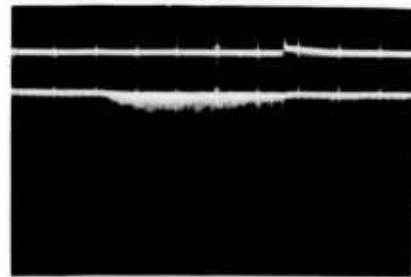

100 μ SEC/CM

GIANT PULSE

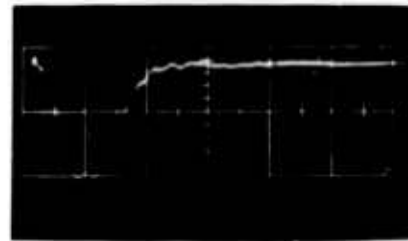

20 nSEC/CM

HIGH PRESSURE TEST CELL

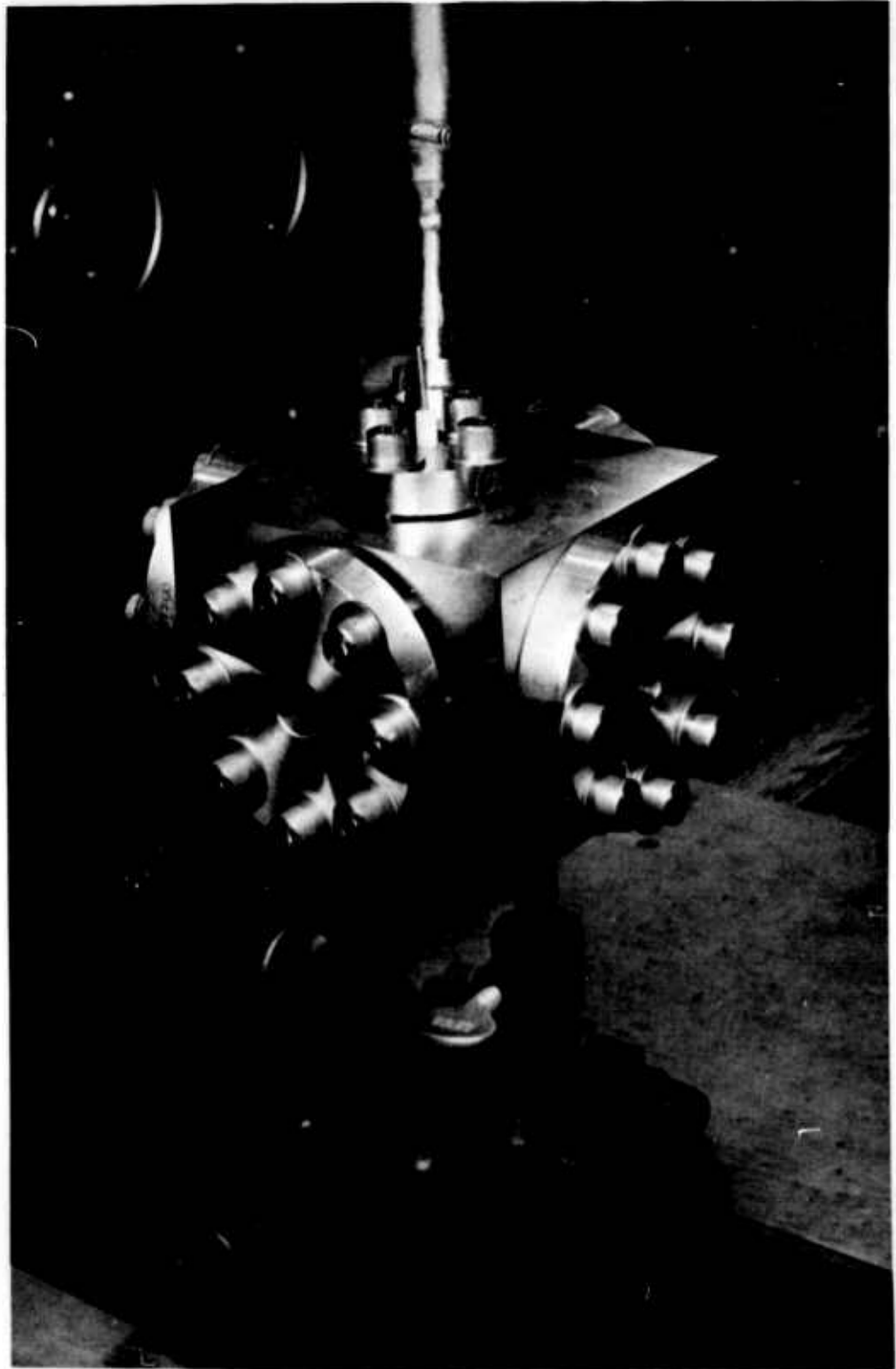

CHARGE PRODUCTION IN BREAKDOWN

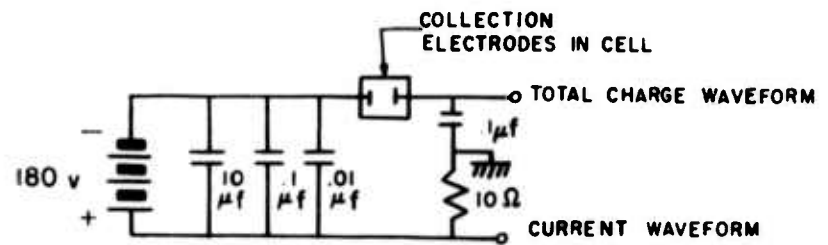

CURRENT WAVEFORM
(5 AMP/CM)

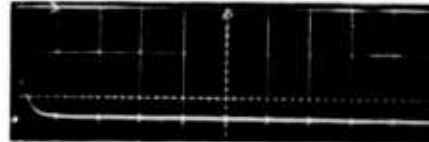

TOTAL CHARGE WAVEFORM
(16×10^{13} e/cm)

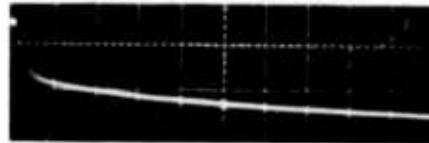

1 μSEC/CM

TIME SEQUENCE OF GIANT PULSE, CHARGE AND LUMINOSITY

GIANT PULSE
LUMINOSITY

TOTAL
CHARGE

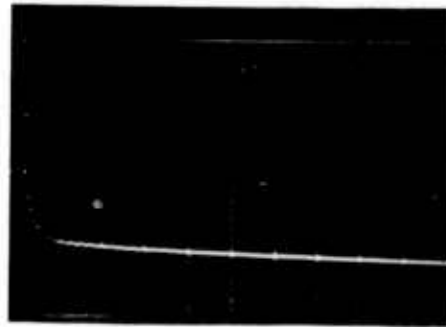

1 μ SEC/CM

BREAKDOWN
LUMINOSITY

TOTAL
CHARGE

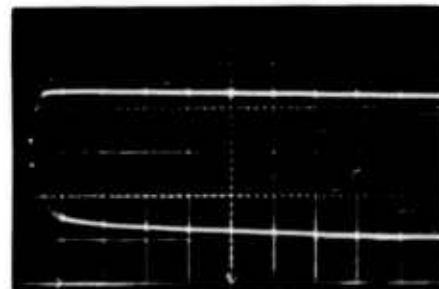

1 μ SEC/CM

BREAKDOWN FIELD STRENGTH AS A
FUNCTION OF PRESSURE

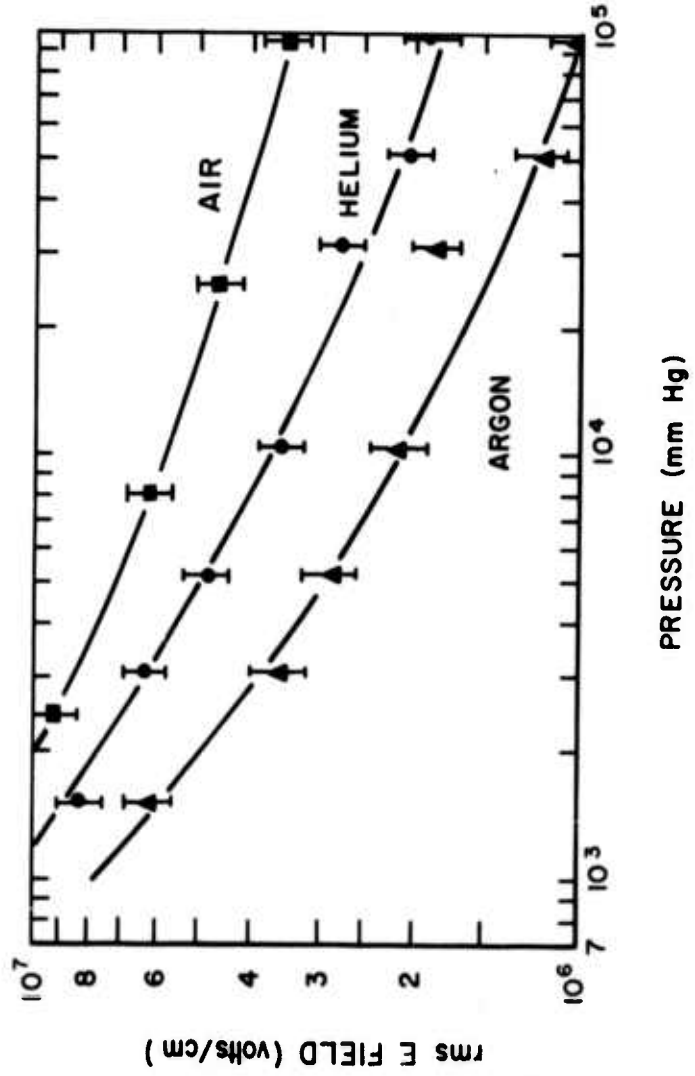

ATTENUATION BY BREAKDOWN PLASMA

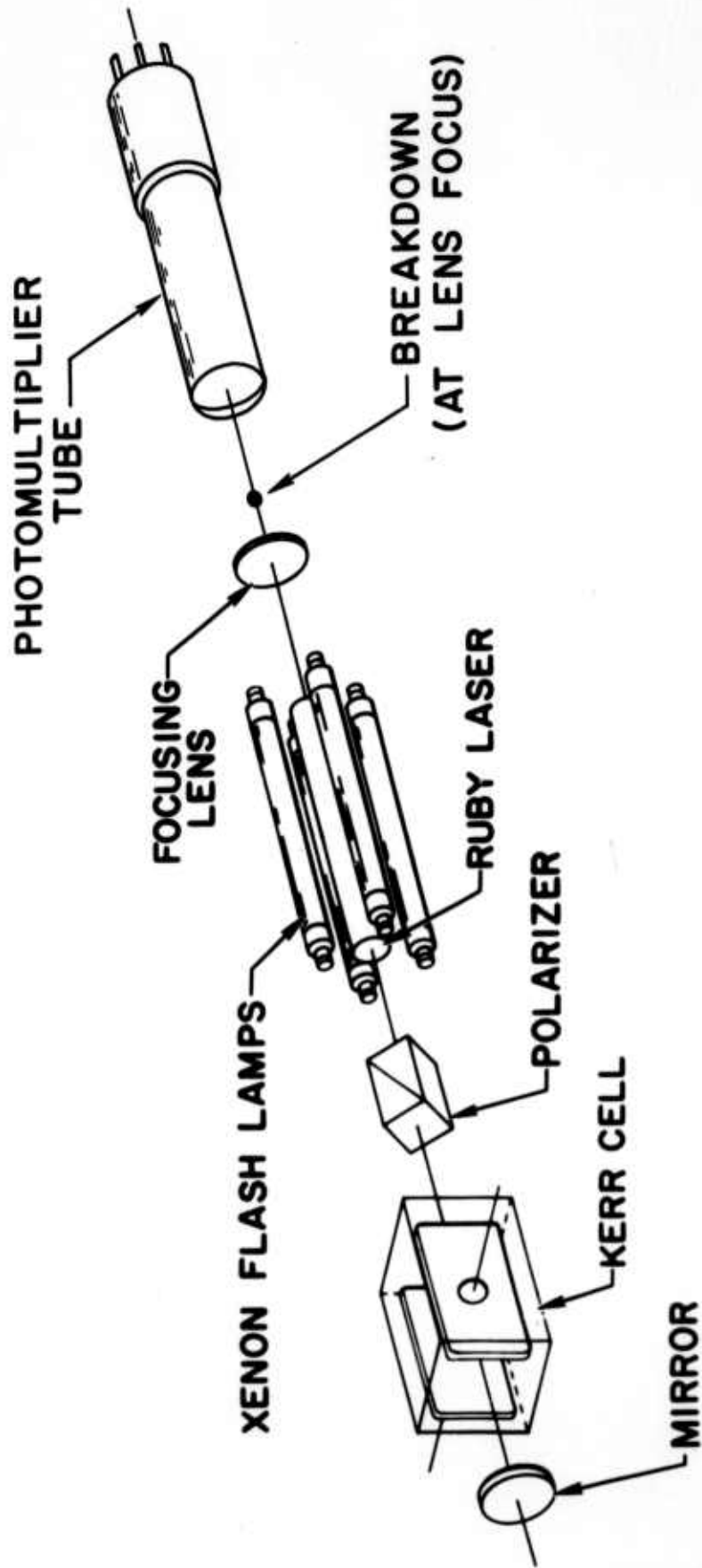

ATTENUATION OF LASER BEAM

NO BREAKDOWN
GAS BREAKDOWN



OPTICAL INTENSITY

10 nsec/cm

BREAKDOWN IN CLOSED VOLUME

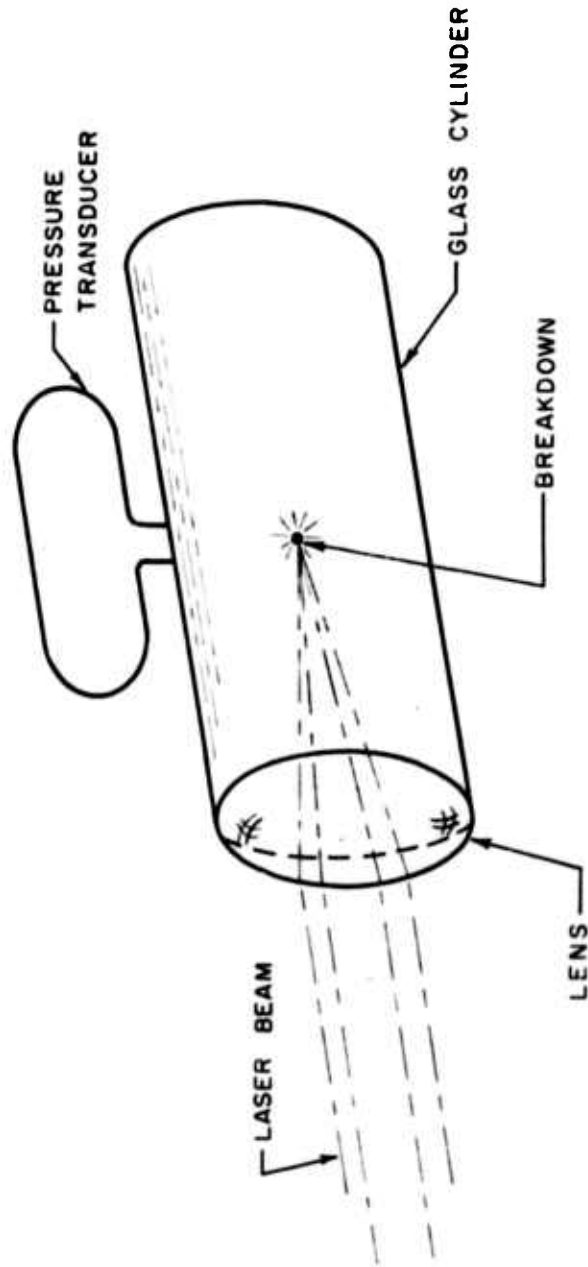

ATTENUATION BY FLASHLAMP PLASMA

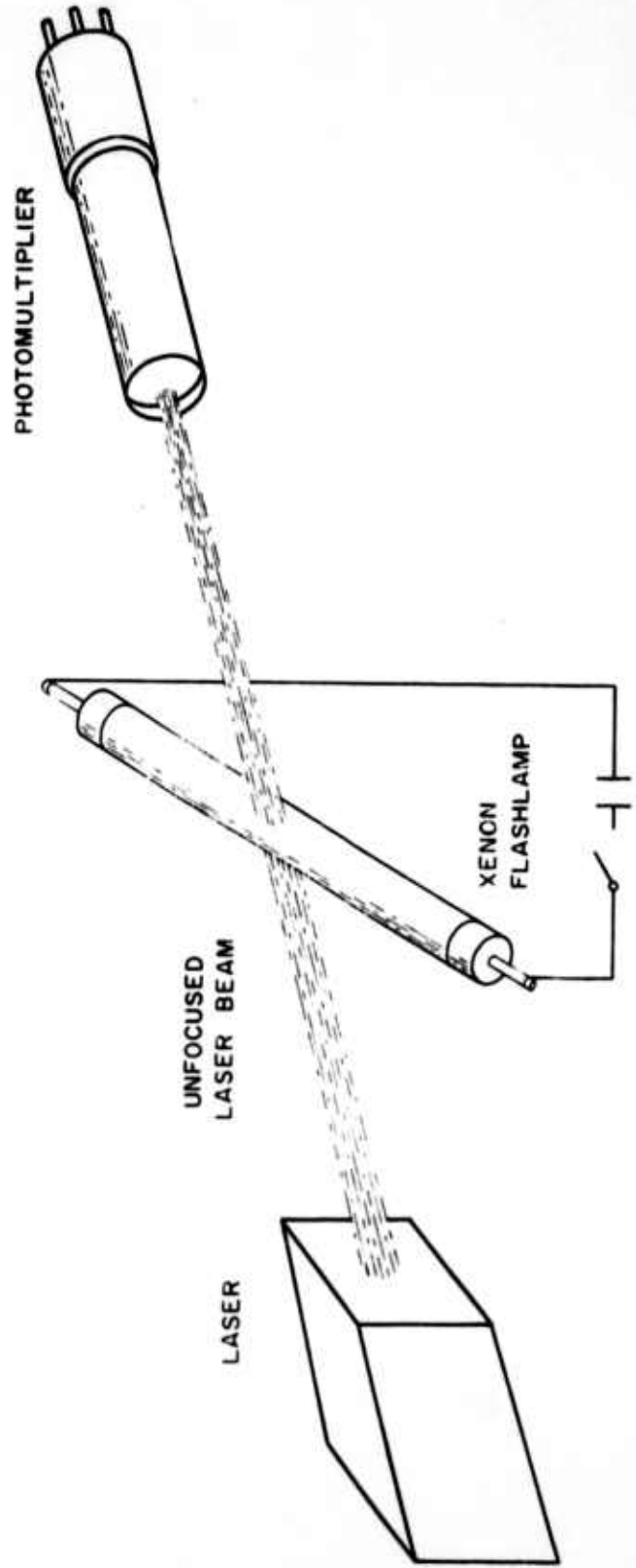

ATTENUATION OF RUBY LASER BEAM BY FLASHLAMP PLASMA

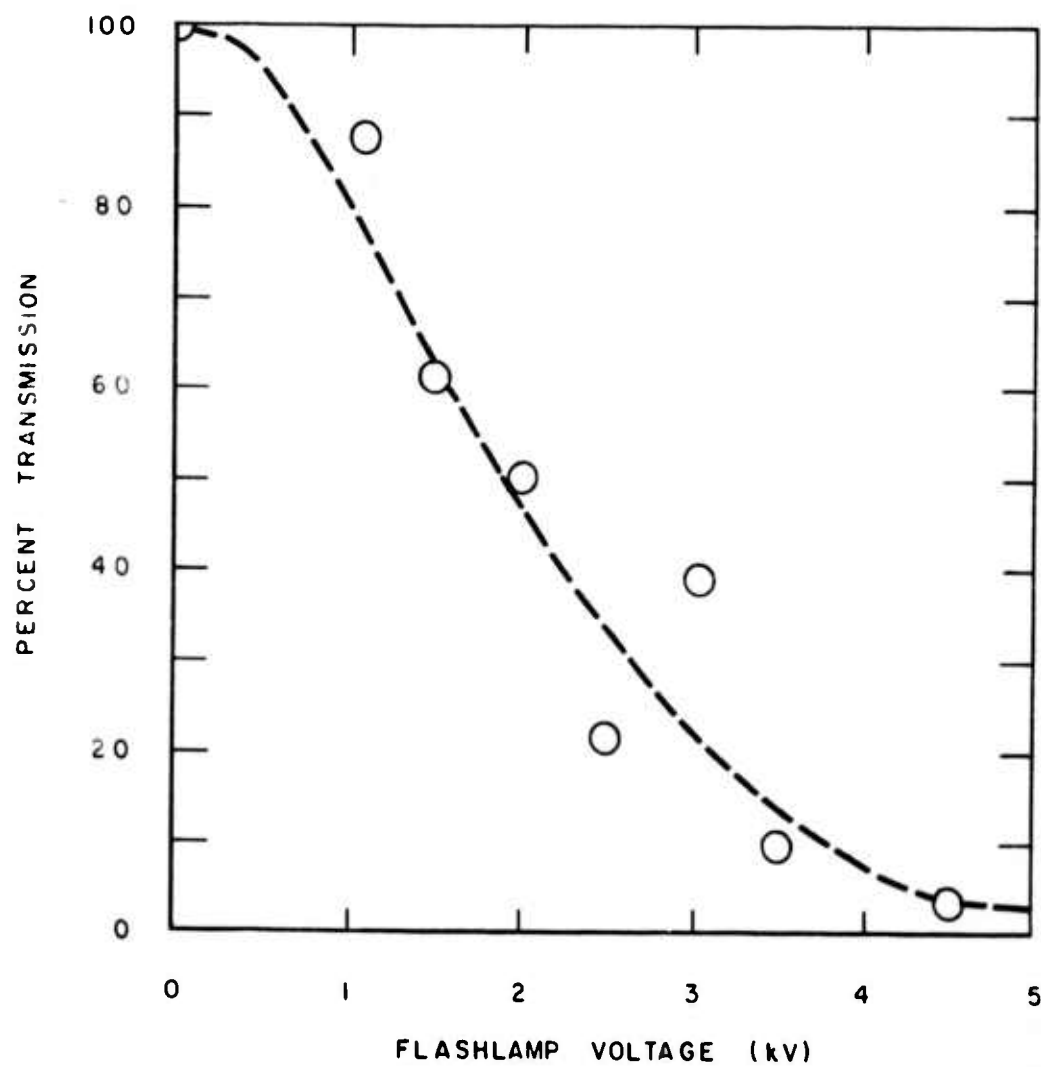

OPTICAL ENERGY ABSORPTION

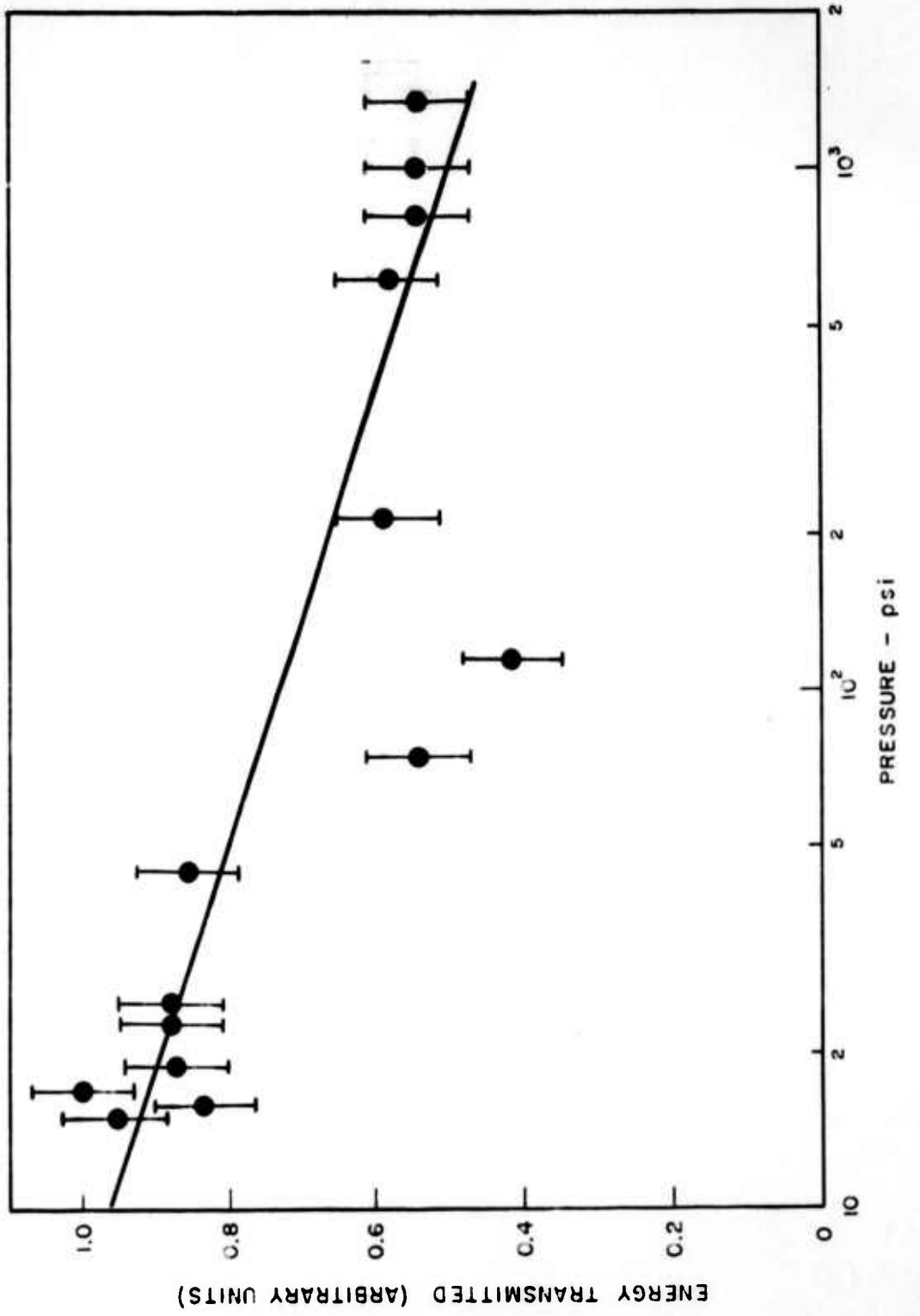

UNCLASSIFIED

UNCLASSIFIED