

UNCLASSIFIED

AD 430654

DEFENSE DOCUMENTATION CENTER

FOR

SCIENTIFIC AND TECHNICAL INFORMATION

CAMERON STATION, ALEXANDRIA, VIRGINIA



UNCLASSIFIED

NOTICE: When government or other drawings, specifications or other data are used for any purpose other than in connection with a definitely related government procurement operation, the U. S. Government thereby incurs no responsibility, nor any obligation whatsoever; and the fact that the Government may have formulated, furnished, or in any way supplied the said drawings, specifications, or other data is not to be regarded by implication or otherwise as in any manner licensing the holder or any other person or corporation, or conveying any rights or permission to manufacture, use or sell any patented invention that may in any way be related thereto.

**BLANK PAGES
IN THIS
DOCUMENT
WERE NOT
FILMED**

64-7

430654

(unclassified title)

PHOENIX

MISSILE SYSTEM

CATALOGED BY DDC

AS AD No. _____

430654



DDC
 MAR 3 1964
 TISIA 2

HUGHES

AEROSPACE GROUP
 AERONAUTICAL SYSTEMS DIVISION
 HUGHES AIRCRAFT COMPANY
 CULVER CITY, CALIFORNIA

PHOENIX Missile System

29 August 1963

•
Transient Gamma
Radiation Effects
on Electronic
Systems

•
Supplement to
PMS-53-1/1720

•
FR 63-17-179

Qualified requesters may obtain
copies of this report direct from
DDC.

GROUND SYSTEMS GROUP
NUCLEONICS RESEARCH DEPARTMENT
HUGHES AIRCRAFT COMPANY
FULLERTON, CALIFORNIA

HUGHES

32051

TABLE OF CONTENTS

	<u>Page</u>
INTRODUCTION: Transient Gamma Radiation Effects on Electronic Systems	1
PART II: Transient Gamma Radiation Effects on Electronics	5
PART III: General Component Effects Under Transient Gamma Radiation	9
PART IV: Transient Radiation Effects on Electronic Passive Parts	13
PART V: Transistors	23
PART VI: Diodes	39
PART VII: Transient Gamma Radiation Effects on Micro-electronic Circuitry	51
PART VIII: Transient Gamma Radiation Effects on I-R Detectors	63
PART IX: Transient Radiation Effects on Silicon Controlled Rectifiers (SCR)	71
PART X: A Survey of Transient Gamma Radiation Effects on Amplifiers	77
PART XI: A Survey of Gamma Radiation Effects on Oscillators and Multivibrators	87
PART XII: Mathematical Techniques for Analyzing Irradiated Circuits	99
PART XIII: Electronic Systems in Nuclear Radiation Environments	107
PART XIV: Transient Radiation Effects on Magnetic Devices	113
PART XV: Methods to Harden a System	117
PART XVI: Technical Appendix No. 1 - Fundamental Principles and Units	121
PART XVII: Appendix No. II - Technical Notes on Materials	126

ABSTRACT

This document contains a series of summaries of the current state-of-the-Art on transient gamma radiation effects on electronics. The state-of-the-art was compiled by the Nucleonics Research Department of the Hughes Aircraft Company for the PHOENIX Project Officer. It contains the present thinking of this department on transient radiation effects.

PART I
INTRODUCTION

TRANSIENT GAMMA RADIATION EFFECTS
ON ELECTRONIC SYSTEMS

I. INTRODUCTION

The problem of nuclear radiation effects on military systems has become one of great concern and importance, since the development and tactical employment of nuclear weapons. Guided missiles systems are of special interest because they rely on pre-programming or self-guidance which cannot be corrected easily if the program or guidance is perturbed by the radiation from a nuclear weapon. The nuclear weapon environment could be produced by enemy penetration or by our missiles used in tactical defense.

The energy release in a nuclear weapon detonation in the atmosphere appears in several forms. The largest portion of the energy appears as thermal shock and blast energy. Only a fraction (of the order of one percent) of the yield appears in the initial radiation. The initial radiation is in the form of a pulse of gamma rays followed, after a delay depending on the distance from the detonation, by neutron pulses-- one for 14 Mev fusion neutrons and one for lower energy fission neutrons. Since the gamma ray pulse does not suffer velocity dispersion, it remains sharp. At a range for which the integrated initial dose is 100r, the peak gamma ray rate in the pulse can be as high as 10^8 r/sec. Thus, even at non-lethal total dose levels, the peak gamma ray rate can be very high. For altitudes above sea level, this dose rate can be determined outside of the 5 Psi overpressure range.

It is important to recognize two radiation effects - permanent damage, and transient disturbance. Transient disturbances are approximately the same time duration as circuit time constants; permanent damage time constants are long compared to the circuit time constants. The nuclear radiation environment has been a matter of serious concern for engineering design of reactors. The mechanical and electrical properties of materials suffer degradation as a result of the large radiation dose to which such

materials are subjected. Dose effects are observed for long reactor exposures, mostly permanent damage effects which are usually irreversible. Rate effects are observed when the effects are dependent upon the rate at which the radiation is delivered. Transient effects, however, are usually the result of electronic processes in the irradiated materials. The magnitude of the effect is proportional to the radiation dose rate. The effect dies away after cessation of radiation, with a decay rate which depends on the rate with which electrons return to their original states.

The transient effects on electronic materials can be divided into two categories, charge injection and charge leakage:

1. Gases - Ionization and increases in conductivity.
2. Semiconductors - changes in conductivity, increase in minority carrier concentration, production of electron-hole pairs.
3. Insulators - decreases in insulation resistance and breakdown strength.
4. Emission of electrons from materials by photo and Compton effects.
5. Fluorescence.

All of these classes of effects (except possibly the last one) are reflected in perturbation in the performance of electronic circuits due to charge redistribution. Ionization of the gas surrounding a component provides a leakage path. The effects on semiconductors produce transients in transistors. The emission of charge from components produces voltage pulses. The change in insulation affects the performance of capacitors, and other components dependent on dielectric materials.

The threat of transient radiation effects to the reliable performance of a missile system arises from the fact that radiation pulses which contain a negligible total dose can produce spurious signals in electronic systems. The magnitude of the signals is proportional to the amplitude of the radia-

tion pulse. The radiation produced signals may lead to degradation of performance or to a catastrophic irreversible occurrence, such as arming and exploding the warhead, which aborts the mission (by premature detonations). The evaluation of the threat must be based on consideration of the operational use and reliability of exposure of the system components to nuclear radiation. The volume of space in which a threat exists can be large.

Pressure of the Blast Wave

The explosion of the nuclear weapon results in a blast wave. The increase in pressure due to the blast wave is termed overpressure. The peak overpressure is the maximum pressure attained. This blast wave has associated a dynamic pressure due to the motion of the air. The peak overpressure and the dynamic pressure must be considered as an environment because these act on the structural parts. The peak overpressure is capable of collapsing a structure and the dynamic pressure is capable of moving the structure along with it.

Nature of Gamma Pulse

Although the gamma rays are emitted from the weapon in a spectrum of energies, the gamma rays which are not absorbed in the surroundings or have suffered collisions with the atmospheric molecules, travel at the same velocity. They, therefore, arrive at a given point at the same time. The majority of the gamma rays arrive in a pulse with a time interval of less than 10^{-6} sec. However, the neutrons have a velocity distribution and thus arrive at a given point in a much larger interval of time than the increase in the gamma ray rate.

PART II
TRANSIENT GAMMA RADIATION EFFECTS
ON ELECTRONICS

CHARGE REDISTRIBUTION

All basic mechanisms involved in material and component reactions to nuclear radiation have only one effect on the electronic responses of circuits and systems. That effect is the redistribution of charge. The alteration of charge may be due to ionization leakage, pair production, photoelectric effect, Compton scattering, or lattice displacements. The manifestation of the physical changes may occur in various forms. Leakage between circuit nodes of different potential may cause an internal or external movement of charge. An effective generation of currents may occur because of charge scattered into or out of components or materials. Fields may be created and leakages may result from scattering and lattice displacements in insulators. In specific instances, circuit charge may be altered because of a variation in a forcing function which is dependent upon mechanical or optical devices, e.g., an optical transistor system might change its output because of lens coloring due to lattice displacements.

Charge redistribution can affect the amplitude, phase, frequency and mode of circuit operation. These circuit characteristics can be described in terms of radiation responses by defining the magnitude, time, and character of the charge redistribution and recovery. Two types of charge alteration are significant--transient and permanent. Transient effects are those which occur during or within circuit time constants after the initial radiation disturbance. Those effects which occur and recover during the radiation pulse and which exhibit a characteristic shape similar to that of the radiation pulse are transient rate effects. Those effects which occur and recover within circuit time constants or system operating times are transient relaxation effects and generally are a function of integrated dose delivered in a very short time. Those effects which are very long with respect to time of interest are permanent or semi-permanent dose effects. Secondary permanent effects, such as mechanical failure due to thermal expansion as a result of transient radiation, may occur at high dose rates; however, these effects need not be considered except as a limiting case.

Circuit responses are due to the interaction of the radiation environment with the materials and components which determine the circuit transfer function. Transient effects involve changes of circuit transfer functions only for a short period of time during charge redistribution. After the magnitude of charge redistribution reaches a maximum, circuits recover in a manner determined practically by their pre-radiation transfer functions. Permanent effects involve long term changes of transfer functions, which can be considered as new definitions of circuit and system responses. If the magnitude, time, and character of charge redistribution are defined and the permanent changes in circuit transfer functions are known, then complete radiation responses can be predicted.

PART III
GENERAL COMPONENT EFFECTS UNDER TRANSIENT
GAMMA RADIATION

RESISTORS

The effective resistance of 10 K ohm resistors decrease by 2% or less under radiation. Resistors less than 10 K ohms show little or no effect. 1 megohm resistors decrease in value to 50%. Very high resistant values may decrease as much as 100%. Low impedance circuits are less affected than high impedance circuits. The percent change in resistance is a function of gamma dose rate. Potted or encapsulated resistors are more radiation resistant.

CAPACITORS

The capacitor types most resistant to radiation are mica, glass, and ceramic.

The insulation resistance of most capacitors can be expected to decrease by several orders of magnitudes in the presence of radiation due to gamma-induced ionization. The internal leakage resistance is also a function of gamma dose rate.

TRANSISTORS

Radiation induced transient responses in transistors are known to be dependent on the base geometry and type of surface of the device. In general, transistors with narrow base widths, (i.e. high cutoff frequencies) are less sensitive to transient radiation effects than similar devices with wider base widths, (i.e., lower cutoff frequencies). It has also been found that planar and mesa construction techniques are more resistant to radiation effects than their alloy counterparts. Thus, an example of the most satisfactory type of transistor from the radiation resistance standpoint is considered to be a high frequency silicon planar, such as a 2N709 or 2N917.

Germanium transistors, under a radiation burst, their reverse leakage current I_{CBO} , increased to values ranging up to 3300 μ amps.

For silicon pnp transistors under a burst, the I_{CBO} values increased up to 180 μ amps. For silicon npn transistors, the I_{CBO} value increased up to values as high as 800 μ amps. The silicon pnp transistors were less affected than the silicon npn type.

DIODES

In general it can be said that the diodes are less affected than the transistors. The transient leakage currents in diodes are roughly proportional to the depletion layer volume. Reverse bias diodes are extremely sensitive to transient radiation effects. Forward bias diodes show little or no effect to the same environment. The magnitude of the induced transient are proportional to the product of the junction area and the diffusion length of the device. Hence, power diodes are more likely to induce circuit malfunctions than the higher speed switching diodes. There is no indication that the tunnel diodes show a transient change.

ELECTRON TUBES

Magnetrons and light sensitive tubes exhibit the least resistance to radiation. Regulator tubes in a non-conducting state were triggered into conduction by a radiation burst. If the tube did not conduct, the leakage current increased by 150%. Thyratrons can be triggered by a transient radiation pulse. Receiving tubes are less sensitive to radiation than semiconductor devices.

CABLE

Gamma radiation produces a current proportional to radiation dose rate; the central wire going negative with respect to the shield. In RG-58 cable, the gamma response was found to be about 4×10^{-14} coulombs/rad-cm. The gamma sensitivity was found to remain essentially independent of previous exposure to gamma rays or neutrons.

The signal due to gamma fluxes is negative and nearly proportional to the intensity. There is no large saturation effect and no change in sensitivity due to previous exposure.

OSCILLATOR

Oscillators operating in the frequency range of 40 - 70 KC exhibited frequency shifts between 4 to 20%. A blocking oscillator increased output amplitude 70% to 90%.

IR DETECTORS

Infrared detectors exposed to nuclear radiation show an effective shunt conductance and injected current effect due to the radiation. The electrical response of infrared detectors with time constants short, compared to the time constant of the radiation pulse, can be largely cancelled with the addition of an equivalent "voltage plane" near the detector. Detectors having a characteristic time constant sufficiently longer than the time duration of the radiation pulse will show a recovery time determined by the inherent time constant of the detector. Analysis of this recovery curve indicated that the infrared sensing mechanism of the detector is severely affected by a radiation dose of approximately 10^6 r/sec. The effect of nuclear radiation induced signals from IR detectors on IR systems depends upon the application of the system and the system circuits.

MICROELECTRONIC CIRCUITRY

Thin film circuit elements respond to irradiation with a linear relationship to the voltage across the element, while bulk semiconductor circuits exhibit non-linear relationships when subjected to nuclear radiation.

For a given application a thin film circuit will be less sensitive to radiation than the bulk semiconductor circuit by at least one order of magnitude.

SILICON CONTROLLED RECTIFIERS (SCR's)

A negative gate bias makes an SCR less sensitive to switching due to a radiation environment. Placing the load in the anode circuit, rather than the cathode circuit, slightly decreases the radiation induced switching sensitivity.

The value of the load resistor has little, if any, effect on the switching sensitivity. The switching sensitivity is dependent upon the dose rate and also the radiation pulse width.

PART IV
TRANSIENT RADIATION EFFECTS ON ELECTRONIC
PASSIVE PARTS

I. INTRODUCTION

This is a discussion of transient radiation effects on electronic passive parts. The purpose is to inform circuit and system designers of problems resulting from transient nuclear radiation and methods of incorporating this information into their design procedures.

The areas under discussion are resistors, capacitors, and coaxial cables.

II. GENERAL DISCUSSION

Transient effects are almost entirely due to gamma component of nuclear radiation. Basic considerations lead to conclusions that external air leakage is the major effect in most passive parts. Internal effects (leakage, polarization) can probably be related to internal capacitance, and since internal capacitance is small on most passive parts, internal effects are small and difficult to measure.

The importance of internal and external leakages and polarization effects will be given in each area. Equivalent circuits and empirical relationships are presented from results presently available.

III. RESISTORS

Transient radiation effects in resistors will be treated in two ways: (1) response of resistors in general, and (2) the effects upon resistor materials.

a. Radiation Effect on Resistors

External air leakage is the major effect for all resistors. Empirical relationships have been developed to predict leakage values and how circuits can be effected.

The equivalent circuit⁽¹⁾ of a resistor before and during irradiation is shown in Figure 1, where R is the nominal resistance of the resistor, and R_s is the radiation induced shunt leakage due to ionization of the surrounding material and air. The current generator I_j represents the injected current induced by the radiation pulse through secondary emission.

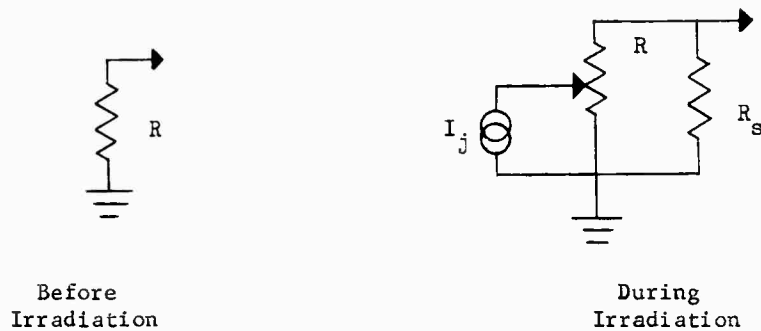

FIGURE 1. EQUIVALENT CIRCUIT FOR A RESISTOR BEFORE AND DURING IRRADIATION

For unpotted resistors,

$$R_s = \frac{(2 - 1)10^{+2}}{\dot{\gamma}} \text{ ohms.} \quad (\text{Equation 1})^{(1)}$$

For paraffin dipped resistors,

$$R_s = \frac{(8 - 5)10^{+2}}{\dot{\gamma}} \text{ ohms} \quad (\text{Equation 2})^{(1)}$$

where $\dot{\gamma}$ = gamma dose rate in R/sec.

The effective resistant, R_{eff} , is reduced during the pulse of radiation, and given as,

$$R_{\text{eff}} = \frac{RR_s}{R + R_s} \text{ ohms.} \quad (\text{Equation 3})^{(1)}$$

The radiation induced shunt leakage resistance (in air) at 10^7 r/sec is approximately 300 K ohms. The effective resistance, R_{eff} , is 1 K ohms when using a nominal resistance of 1 K ohms. For a one megohm resistor, the effective resistance is 91 K ohms.

Thus, low impedance circuits are less effected than high impedance circuits.

b. Radiation Effects on Resistor Material

In the F111B system the pilot is most sensitive to total dose radiation effects. Since the total dose must be small for his safety, resistor materials will not suffer any permanent changes.

Dose effects are mentioned because transient radiation may lead to permanent damage under very high dose rate conditions. The following discussion applies only to unmanned aircraft and vehicles.

1. Compounds embodying organic materials in their structure should be avoided. ⁽²⁾
2. When selecting metal and carbon-film resistors for use in radiation environment, only molded and hermetic seal types should be used. ⁽³⁾
3. Inorganic materials are more stable and resistant to radiation damage than are organic materials. ⁽³⁾
4. Ceramics exhibit better insulation qualities during irradiation than organic polymers. ⁽³⁾
5. Glasses containing boron are most sensitive to structural damage under irradiation. ⁽³⁾

These effects and suggestions are for some of the more common resistor materials, and is by no means a complete list. Manufacturing processes of these materials will also effect radiation responses. Some resistors are of the solid core type and others are partially filled with air or gas. Those resistors employing air or gas generally have larger responses than those with a solid core.

When humans are involved, the above suggestions need not be followed.

In conclusion, the present change in resistance during transient radiation can be calculated from Equation 3. Such things as resistor material, manufacturing processes, and temperature are also known to effect responses to some degree.

IV. CAPACITORS

Capacitors belong to a class of components which is recognized as being among those most effected by nuclear radiation.

Internal and external leakages, as well as capacitance changes, are areas of concern.

a. External Leakage

External air leakages occur between the capacitor leads, as occurs for resistors.

b. Internal Leakage

Empirical relationships have been developed for calculating leakage conductivities during a radiation pulse.

The equivalent circuit⁽¹⁾ of a capacitor before and during irradiation is given in Figure 2, where C is nominal value of the capacitor and R is a pure leakage resistance. R_s is the radiation induced shunt resistance and C_s is the shunt capacitance (or change of capacitances, ΔC). I_j represents the injected current induced by the radiation pulse through secondary emission.

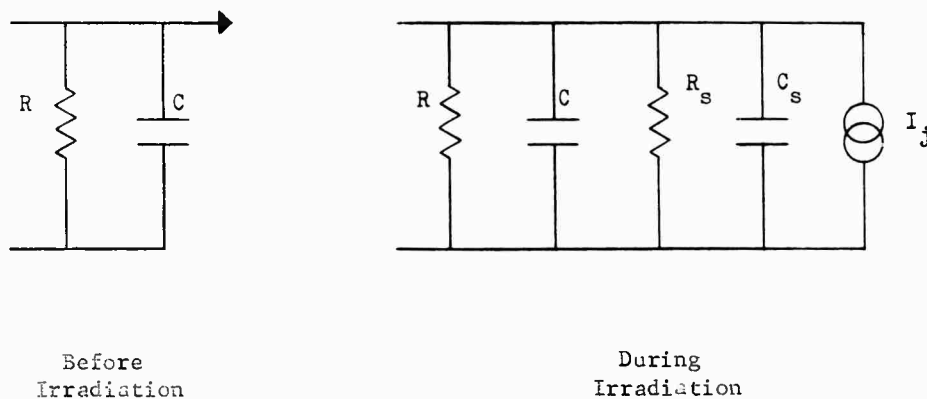

FIGURE 2. EQUIVALENT CIRCUIT FOR A CAPACITOR BEFORE AND DURING IRRADIATION

For a parallel plate geometry of plate area A, and separation, l , we have

$$G = \sigma \frac{A}{l} \text{ and } C = \epsilon \frac{A}{l} \quad (4,7)$$

where σ = leakage conductivity

ϵ = dielectric permittivity

G = internal leakage conductance

C = capacitance

Thus, G and C are related by (1,4)

$$G = \sigma \frac{C}{\epsilon \epsilon_0} \text{ mhos or } R_s = \frac{\epsilon \epsilon_0}{\sigma C} \quad (\text{Equation 4})$$

$$\epsilon_0 = 8.85 \times 10^{-14} \text{ farad/cm}$$

Leakage conductivity can be calculated from the following formula:

$$\sigma = K_c \dot{\gamma}^\Delta \text{ mhos/cm} \quad (1,5,8) \quad (\text{Equation 5})$$

where K_c = proportionality factory

$\dot{\gamma}$ = gamma dose rate (r/sec)

Δ = constant for material (range between 0.5 and 1.0)

When the internal leakage conductance has been determined experimentally, leakage conductivity can be calculated from Equation 4. On the other hand, internal leakage conductance can be calculated by just using Equation 5.

Transient conductivity factors for various dielectrics are listed in Table 1. (1)

TABLE 1. TRANSIENT CONDUCTIVITY FACTORS FOR DIELECTRICS

<u>Dielectric Material</u>	<u>ϵ</u>	<u>KC</u>	<u>Δ</u>
Mylar	3	4.2×10^{-7}	0.9
Vitamin Q - impregnated paper	11	5.2×10^{-15}	0.7
Tantalum Oxide	25	1.2×10^{-17}	1.0
Aluminum Oxide	7	2.95×10^{-18}	1.0
Glass	6.5	1.0×10^{-17} (est)	1.0 (est)
Oil-impregnated paper	~7.0	$\sim 7.4 \times 10^{-17}$	~1.0

It is seen that internal leakage conductance becomes insignificant for small value capacitors when gamma dose rate, $\dot{\gamma}$, is less than 10^6 R/sec.

The effective resistance, R_{eff} , during a pulse of radiation, is given as

$$R_{\text{eff}} = \frac{RR_s}{R + R_s} \text{ ohms} \quad (\text{Equation 6})$$

Typical calculations for leakage conductivity and internal leakage conductance are given. From Table 1, $\epsilon = 3$, $K_C = 4.2 \times 10^{-17}$, and $\Delta = 0.9$ for Mylar dielectric material. For a gamma dose rate of 10^7 r/sec, $\frac{\sigma}{\epsilon\epsilon_0} = 317$ mhos/farad.

Similar calculations for tantalum oxide capacitor reveals $\frac{\sigma}{\epsilon\epsilon_0} = 54.4$ mhos/farad. The value of internal leakage resistance for mylar capacitors is approximately six times that of tantalum oxide capacitors.

Tantalum and aluminum oxide capacitors are least sensitive to internal leakages from transient radiation. Oil-impregnated paper capacitors appear to be most sensitive to internal leakages.

Thus, transient radiation effects on capacitors will depend on (1) capacitance value; (2) dielectric material; (3) gamma dose rate in R/sec.

c. Capacitance Changes

The value of C_s or Δ_C , is assumed to be insignificant since changes of 1% or greater have not been observed. If capacitance changes do occur, it is believed to be less than 1%.

V. COAXIAL CABLES

The major radiation effects in coaxial cables are due to air ionization around the exposed lead of the cable. Internal leakage within the cable dielectric becomes insignificant when compared to the external leakage.

Due to scattering of electrons out of the coaxial cable, positive pulse currents are observed at zero voltage. Cable leakage causes negative pulse currents at large positive voltages. These effects, however, are cancelled out at a certain voltage, referred to "crossover"^(r,6) voltage, which lies in the vicinity of +10 volts for solid dielectric cables.

These leakage currents can be minimized to one microampere or less by raising the potential of the outer conductor (shield) to that of the inner conductor so that the potential difference is equal to the cross-over voltage.

The applicator of this "crossover" voltage technique is mentioned because it has been used to minimize the interfering effects from coaxial cables.

VI. ELIMINATION OF EXTERNAL LEAKAGE

Although little can be done to reduce internal leakages, external leakage can be reduced or eliminated quite successfully.

External leakages are due to ionization of the surrounding material and air. Electrostatic shielding and potting are two methods now used to minimize these leakages.

Electrostatic shielding eliminates the electrostatic field lines, while potting compounds eliminate the air from around the component. Care must be taken when using potting compounds because secondary emission from bulk potting materials may become another significant problem.

REFERENCES

1. Transient Radiation Effects to Electronic Parts and Materials, Number D2-6594, Boeing Airplane Company, Feb., 1961.
2. Doshay, I., Dynamic Radiation Evaluations of Passive Components in Combined Environments, Space-General Corp., Conference Paper, June 1963.
3. The Effects of Nuclear Radiation on Resistors and Resistor Materials, Battelle Memorial Institute, REIC Memorandum 20, January 15, 1960.
4. Perkins, C. W., Transient Radiation Effects on Passive Parts, First Quarterly Progress Report under contract DA 36-039-SC89112, Hughes Aircraft Company, June 1 to August 31, 1962.
5. Fowler, J. F., X-Ray Induced Conductivity in Insulating Materials, Proc. of Royal Soc., A236, 464 (1956).
6. Perkins, C. W., Transient Radiation Effects on Passive Parts, Presentation at the TREE Symposium, Hughes Aircraft Company, April 29, 1963.
7. Perkins, C. W., Transient Radiation Effects on Passive Parts, Second and Third Quarterly Progress Reports, under contract DA 36-039-SC89112, Hughes Aircraft Company, 1 September 1962 to 28 February 1963.
8. Conrad, E. E., Marcus, S.M., Gamma Induced Photoconductivity in a Polyethylene Terephthalate Capacitor, Harry Diamond Laboratories (DOFL), TR-1037, May 1962.

PART V
TRANSISTORS

TRANSISTORS

I. INTRODUCTION

Electronic components constructed from semiconducting materials are known to be exceptionally sensitive to ionization effects caused by high energy electromagnetic radiation. For example, the resulting transient changes in the electrical parameters of the transistor in such an environment may cause temporary circuit failures. For this reason, extensive study programs have been pursued to determine the nature of these effects and which types of devices are least susceptible to these transient radiation effects.

The present state-of-the-art is far from the capability of providing components which are impervious to transient radiation effects, however, certain generalizations can be made as to a selection of device types and geometries which are relatively radiation resistant. These results are presented together with a summary of the existing information concerning the magnitude of radiation induced responses measured on commercially available transistors.

The significance of transistor geometry, fabrication technique, initial gain, and surface treatment as they effect the transient radiation response are discussed in preceeding sections. In addition, examples of typical variations of the electrical parameters during a burst of gamma radiation and a brief description of transient phenomena of longer duration than the radiation burst are given.

Certain assumptions have been made in the acquisition of this data, which should be pointed out. The response magnitudes given in this report were measured at a gamma dose rate of $\sim 10^7$ r/sec. The data was taken at the Hughes Research Linac, The General Atomic's Linac and The Sandia Pulsed Reactor Facility (SPRF). Although the gamma dose rates at each of these facilities is $1-2 \times 10^7$ r/sec, the first two provide .1 - 10 μ s pulses of essentially pure Bremsstrahlung (gamma) radiation,

while the latter gives a combined gamma and neutron environment of $\sim 50 \mu\text{sec}$ pulse duration.

II. GEOMETRY

Geometrical considerations of the base width, junction area^(4,5) and depletion layer volume^(4,5) are most significant when attempting to minimize the transient radiation effects. The junction area and depletion layer volume parameters are seldom specified by manufacturers, consequently, they are of little practical use when selecting components which are more impervious to transient radiation effects.

However, the base width of the transistor is inversely proportional to the cutoff frequency. Since approximate cutoff frequencies are normally given in transistor specifications, they provide a useful guide to minimizing the expected transient responses. As shown in Figure 1, the normalized transient gain, during a 2×10^7 r/sec burst of gamma radiation ($\Delta I_c / \Delta I_B / h_{FE0}$), in the common emitter configuration is a strong function of the beta cutoff frequency. Similar plots for a variety of device types has lead to the conclusion that smaller base widths, (i.e., higher cutoff frequency devices), are less susceptible to transient radiation effects than their wider base widths, (i.e., lower cutoff frequency) counterparts.

III. CONSTRUCTION TECHNIQUES

A limited amount of data is available concerning which fabrication techniques and surface treatments are most vulnerable to transient radiation effects. From recent studies^(1,2), it is apparent that devices constructed by diffusion techniques such as the Germanium Mesa 2N1142 or the Silicon Planar 2N709 are less susceptible than devices constructed by alloying techniques such as the Germanium Alloy 2N331 or the 2N651. This is understandable because the alloying processes produce larger junction areas and correspondingly larger depletion layer volumes. Additional support for this reasoning can be obtained from similar results on permanent damage studies.⁽³⁾ This is understandable from a materials point of view, since Silicon has a larger forbidden energy gap.

Normalized Transient Gain versus Cutoff Frequency

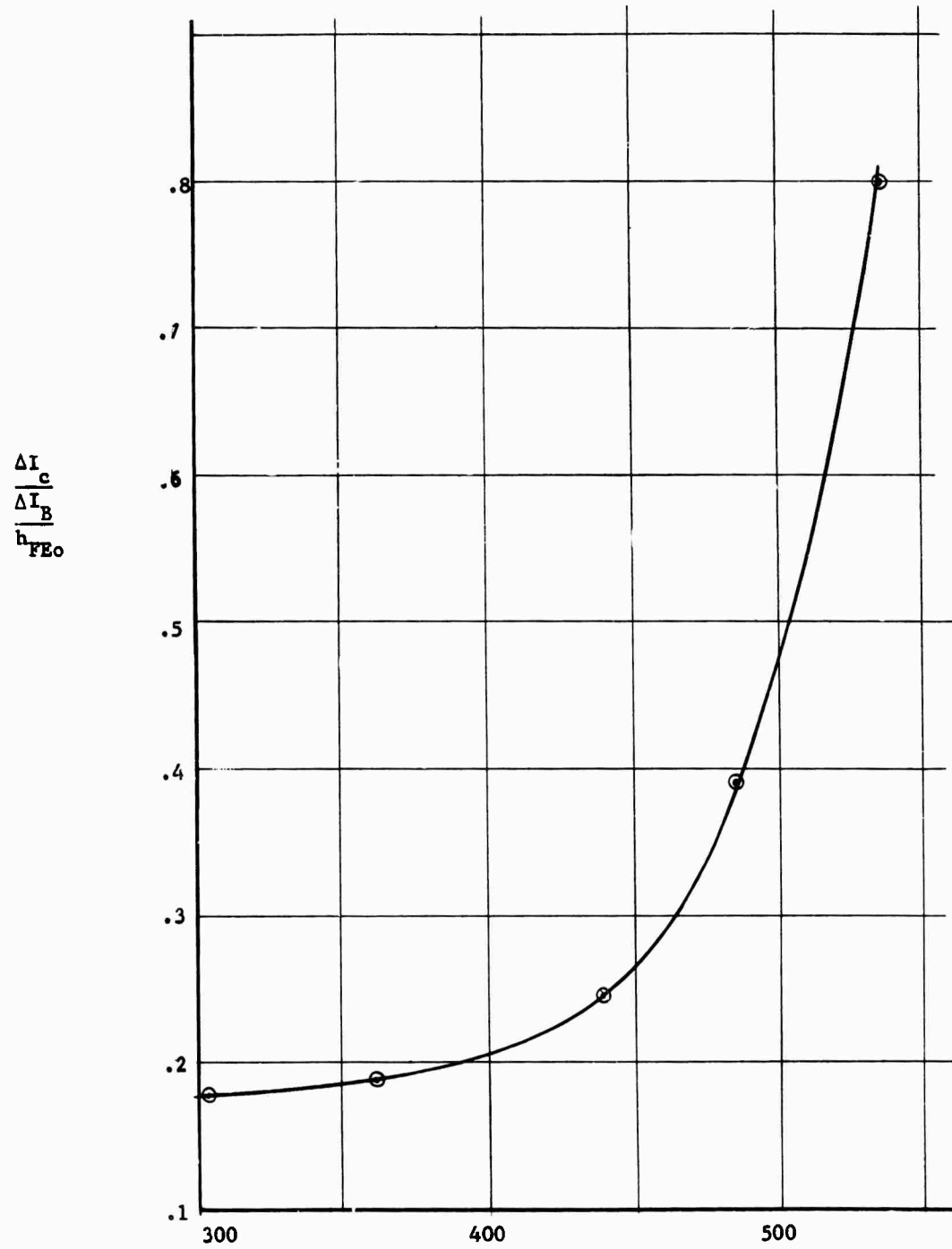

FIGURE 1: CUTOFF FREQUENCY f_{β} (mc)

Surface treatments also play a significant role in the relative radiation resistance of a transistor. Passivated transistor surfaces, such as are found in the Silicon Planar 2N709 or 2N917, are far superior to those found in many other device types. Leakage currents, which are considered to be predominately surface effects, have been found to be one to two orders of magnitude lower in Silicon Planar transistors in a radiation environment than their Germanium Alloy or Mesa counterparts. The amount of information on this subject is limited and accurate comparisons are difficult to make due to the difficulty in controlling other transistor parameters, while comparing surfaces; however, quantitative data will be presented in the next section to substantiate these conclusions.

IV. EXPERIMENTAL OBSERVATIONS

Transient radiation effects studies on transistors were performed at a weapon simulator (Sandia Pulsed Reactor Facility) in Albuquerque, New Mexico. This facility provides a 50 μ s fission spectrum of gamma radiation with a peak gamma dose rate of 2×10^7 r/sec. In addition, research Linacs were utilized to supply similar gamma dose rates with durations of .1 to 10 μ s. The Linac machines do not yield the combined gamma and neutron environment of SPRF, however, due to the short length of their radiation pulse, they enable the experimentors to observe minority carrier recombinations and space charge decay time history obscured by the slower reactor radiation sources. Experiments at both types of radiation facilities will be discussed in this section.

Transient changes in the properties of the transistor are observed by monitoring the typically useful circuit parameters of the transistor, such as h_{FE} , I_{CEO} , I_{CBO} , and V_{SAT} . These test circuits are carefully constructed with fast time constants and proper electromagnetic shielding to insure that the observed voltage signals are representative of the physical phenomena taking place within the irradiated device. Figures 2-4 are examples of these effects occurring in a 2N331 at the Sandia Pulsed Reactor Facility.

The gamma dose rate is shown in Figure 2 for a typical SPRF burst of approximately 2×10^7 r/sec. In most cases the transient changes in the electrical parameters of irradiated transistors closely follow this dose rate curve.

Figure 3 illustrates the radiation induced effects in the 2N331 operating in a common emitter configuration under d.c. bias conditions with a 100Ω collector load. It should be noted that the 3 ma base pulse is inverted and amplified to 75 ma in the collector. The current overshoot from the steady state operating currents is associated with the permanent damage effects of the prompt neutrons, resulting from the fission process.

The collector voltage was monitored for the 2N331 transistor when saturated (1K collector load resistance). Variations in the collector voltage, (the saturation voltage V_{SAT}), were observed as shown in Figure 4.

Leakage currents increase rapidly during the burst of gamma radiation. As shown in Figure 5, the magnitude of I_{CEO} (the open base collector to emitter leakage current), is approximately equal to the change in the collector current in Figure 3. Changes in I_{CBO} (collector to base leakage currents), are roughly a factor of h_{FE} smaller than I_{CEO} .

The initial d.c. current gain is also a determining factor in the magnitude of the transient response. The ratio of the change in collector current to base current has been demonstrated to be a function of the initial gain⁽¹⁾. In addition the dependence of ΔI_{CEO} on h_{FE} during Linac irradiations (see Figure 8) has been observed.⁽²⁾

It should be pointed out that transistors operating at relatively low collector voltages V_c , where $\Delta I_c R_L > V_c$, will saturate during the radiation burst. For this reason, operating voltages selected for radiation testing are normally 4-6 volts.



FIGURE 2: SPRF Gamma Dose Rate versus time (Peak value $\dot{\gamma}=2 \times 10^7$ r/sec)
Horizontal Sweep Speed 50 μ s/cm.

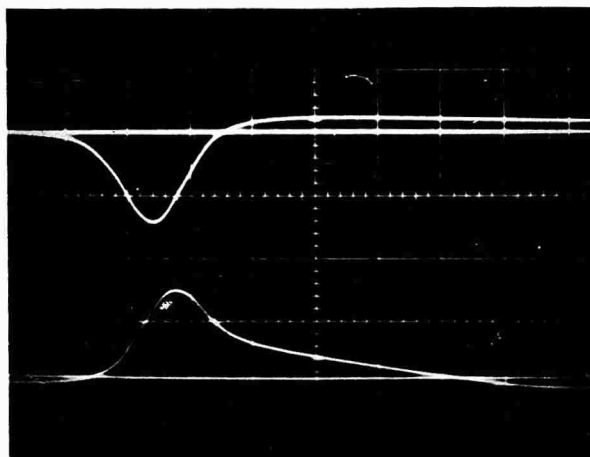

FIGURE 3: Typical h_{FE} of 2N331 response during SPRF Radiation Burst
UPPER TRACE: Collector Current 2 ma/cm
LOWFR TRACE: Base Current 50 ma/cm.
Horizontal Sweep Speed - 50 μ s/cm.

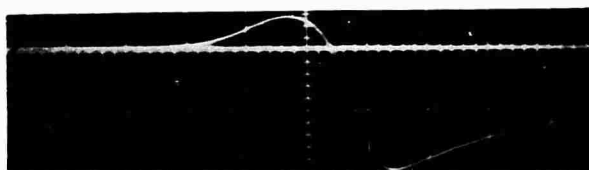

FIGURE 4: Typical V_{SAT} of 2N331 Response during SPRF Burst
Collector Voltage .02 V/cm with 1K load Resistance.
Horizontal Sweep Speed 50 μ s/cm.

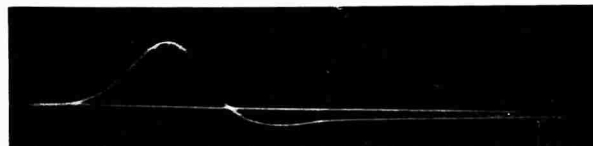

FIGURE 5: Typical I_{CEO} of 2N331 Response during SPRF Burst
Collector Current 50 ma/cm with 100 Ω Load Resistance.
Horizontal Sweep Speed 50 μ s/cm.

The existing data on radiation induced transient responses collected by the Nucleonics Research Department is presented in Table I. Data presented on the 2N331, 2N651, 2N695, 2N1142, 2N706 and 2N709, were acquired during the U. S. Army Signal Corps Figure of Merit Contract, DA 36-039-SC90703. This information represents a statistical average of numerous irradiations under the same test conditions. The balance of information appearing in Table I was acquired in conjunction with the Naval Bureau of Weapons Contract NOrd 19161. Due to the large number of device types tested, only ΔI_{CEO} was monitored during the irradiations. Estimates of the variations in ΔI_c , ΔI_B , ΔI_{CBO} were calculated on the basis that the changes in ΔI_{CEO} and the rough relationships established in the Figure of Merit Studies. These calculations were performed utilizing the initial values of h_{FE} and f_β of the transistors under test. It should be emphasized that the validity of the calculations are limited and are intended to indicate only the relative radiation resistance of the devices under test.

V. OTHER TRANSIENT EFFECTS

Transient radiation effects of longer duration than the ionizing radiation pulse have been observed. If a transistor in the open base configuration is exposed to a pulse of gamma radiation, whose duration is short compared to the minority carrier lifetime of the base material, the decay of the primary photo current due to recombination of minority carriers may be observed (See Figure 6).

Under certain conditions, the ΔI_{CEO} transient pulse may increase after the radiation pulse. This is the "secondary photo current effect" attributed to the delayed discharge of excess majority carriers in the base producing a bias across the emitter-base junction.⁽⁶⁾ This effect is shown in Figure 7. Although an explanation of this effect has been made on the basis of bulk material phenomena, it is known that the magnitude of these effects are dependant on the surface conditions of the transistor.

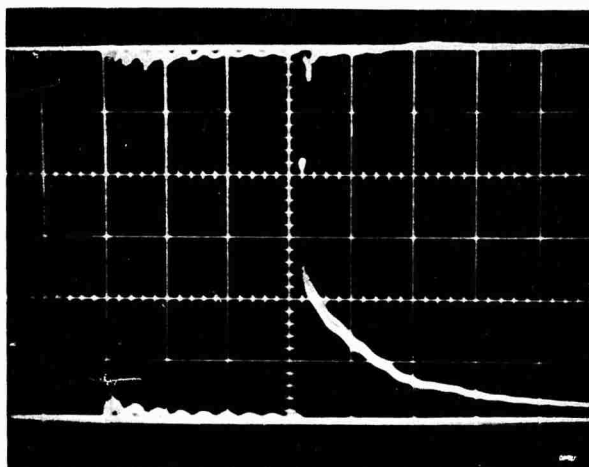

FIGURE 6: Example of Minority Carrier Lifetime Decay During Linac Irradiation of SXF-4
UPPER TRACE: Radiation Dose Rate at Hughes Research Linac
LOWER TRACE: Collector Current 10 ma/cm, Horizontal Sweep Speed 20.8/cm.

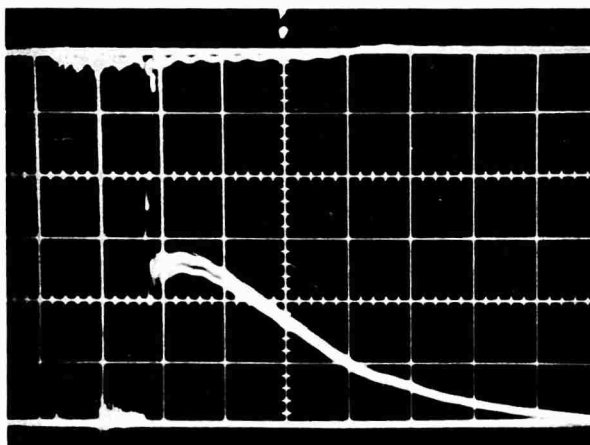

FIGURE 7: Secondary Photocurrent Effect in the I_{GEO} Configuration
UPPER TRACE: Radiation Dose Rate at Hughes Research Linac
LOWER TRACE: Collector Current 2 ma/cm, Horizontal Sweep Speed 2 μ s/cm.

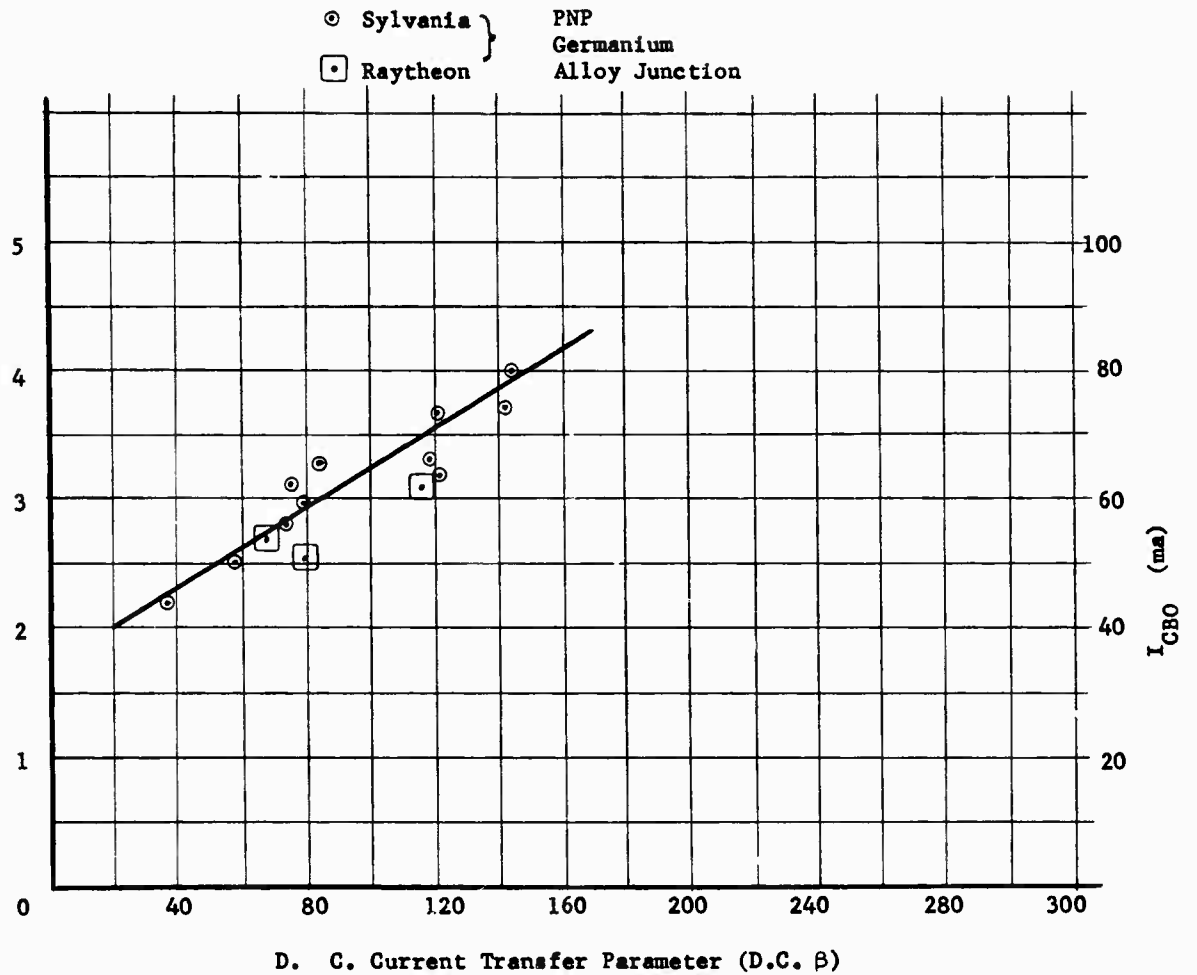

FIGURE 8: PEAK AMPLITUDE VERSUS β , SOLID DIELECTRIC FILLED TRANSISTOR CASES

TABLE I: TYPICAL TRANSIENT RESPONSES TO $\dot{\gamma} \approx 2 \times 10^7$ r/sec

TRANSISTOR NUMBER	f_{β} (mc)	ΔI_B	ΔI_C	ΔV_{SAT}	ΔI_{CBO}	ΔI_{CEO}	Device Type	Manufacturer	Polarity
2N306*	550 KC	5 ma	72 ma	5 ma	80 ma	Ge Alloy	Sylvania	NPN
2N331	120	3.5 ma	77 ma	.013v	3 ma	94 ma	Ge Alloy	Motorola	PNP
2N336*	13	580 μ a	52 ma	580 μ a	58 ma	Si Rate Grown	G. E.	NPN
2N357*	3	5 ma	41 ma	5 ma	46 ma	Ge Alloy	Sylvania	NPN
2N383*	10	890 μ a	58 ma	890 μ a	69 ma	Ge Alloy	Sylvania	PNP
2N395	4.5	58 ma	Ge Alloy	Sylvania	PNP
2N440A*	10	680 μ a	43 ma	680 μ a	48 ma	Ge Alloy	G. E.	PNP
2N450*	7	1.3 ma	36 ma	1.3 ma	40 ma	Si Mesa	G. E.	PNP
2N497*	120	2.5 ma	54 ma	2.5 ma	60 ma	Si Mesa	Transit	NPN
2N498*	120	1.7 ma	36 ma	1.7 ma	40 ma	Si Mesa	TI	NPN
2N525*	2	1.5 ma	58 ma	1.5 ma	64 ma	Ge Alloy	Sylvania	PNP
2N651	1.7	3.1 ma	90 ma	.012v	3 ma	100 ma	Ge Alloy	Motorola	PNP
2N695	450	92 μ a	1.1 ma	.006v	~1/ma	13 ma	Ge Mesa	Motorola	PNP
2N699*	80	375 μ a	27 ma	375 μ a	30 ma	Diffused Planar	Fairchild	NPN
2N706	320	25 μ a	190 μ a	.004v	37 μ a	Si Planar	Fairchild	NPN
2N709	500	~15 μ a	72 μ a	.004v	30 μ a	Si Planar	Fairchild	NPN
2N1101*	10 KC	1.5 ma	47 ma	1.5 ma	52 ma	Ge Alloy	Sylvania	NPN
2N1102*	10 KC	1.4 ma	43 ma	1.4 ma	48 ma	Ge Alloy	Sylvania	NPN
2N1132*	90	660 μ a	36 ma	660 μ a	40 ma	Double Diffused	Hughes	PNP
2N1142	600	52 μ a	490 μ a	.004v	~100 μ a	2.7 ma	Ge Mesa	Motorola	PNP
2N1613*	100	250 μ a	18 ma	250 μ a	20 ma	Diffused Planar	Fairchild	NPN

* Indicates device types on which transient variations are estimated on the basis of experimentally measured values of ΔI_{CEO} .

In Figure 9, the magnitude of those peak transient currents is plotted against radiation pulse width for two devices of similar electrical characteristics. The first device was taken from an assembly line after its surface had been treated to minimize surface effects. The other device was removed before its surface had been treated. Figure 9 illustrated the need for a well passivated surface to minimize transient radiation effects.

VI. SUMMARY

The present state-of-the-art of transient radiation effects testing on transistors indicates that a proper selection of device types by the design engineer may significantly contribute to minimizing the magnitude of these effects. Although the effects will be evident in all known types of transistors, the following criterion may be useful in device selection:

1. Higher frequency units, (i.e., narrower base width transistors) are less sensitive to pulsed radiation.
2. Smaller junction areas and depletion layer volumes are more desirable as they will minimize effects.
3. Transistors utilizing diffusion techniques are more impervious to ionization effects than their alloy counterparts.
4. Silicon transistors are generally less susceptible than Germanium transistors.
5. Device types with highly passivated surfaces such as a planar transistor are more radiation resistant.

Experimental testing of a limited variety of device categories is summarized in Table I to indicate the relative order of magnitude of the transient responses. In general, these ionization effects are proportional to the gamma dose rate during the exposure.

Of course, the ultimate criterion of radiation resistance is whether or not a given gamma dose rate will cause mal-performance of a circuit. Virtually all circuit components will contribute to the transient response

of the total circuit, however, previous experience indicates that semiconductor devices are the major contributors of circuit mal-functions. Analytical techniques have been developed for prediction circuit responses, providing the effects on individual circuit components are known. However, the most reliable method of certifying radiation resistance at a given gamma dose rate is an experimental program which tests both components and circuits.

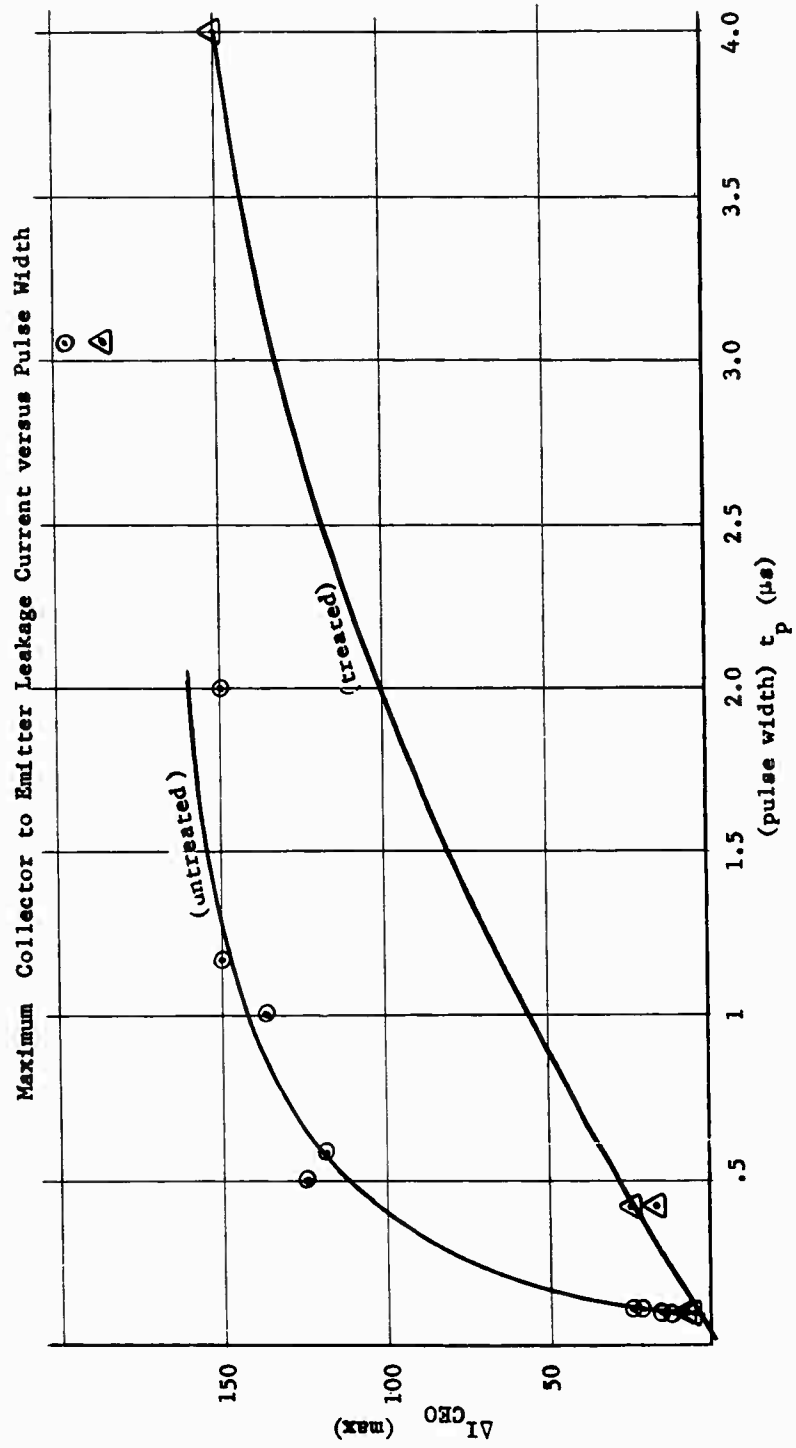

FIGURE 9: THE EFFECT OF SURFACE TREATMENT ON TRANSIENT LEAKAGE CURRENTS

REFERENCES

1. C. W. Perkins, "Determination of Transistor Figure of Merit for Radiation Effects", Hughes Aircraft Co., 1st, 2nd and 3rd Quarterly Reports to U. S. Army Electronics Research and Development.
2. J. E. Bell, R. D. Loveland, "Research and Development on the Effects of Radiation on Electronics Equipment Used in Surface-Launched Guided Missiles", Hughes Aircraft Co., Semi-Annual Technical Progress Report to Department of the Navy, Bureau of Weapons.
3. F. J. Reid, "The Effect of Nuclear Radiation on Semiconductor Devices", Battelle Memorial Institute, REIC Report No. 10, 15 July 1961.
4. D. C. Jones, et al, "Transient Radiation Effect on Electronics Components and Semiconductor Devices", Battelle Memorial Institute REIC Report No. 26, 9 April 1963.
5. J. W. Easley and R. R. Blair, "Transient Phenomena in Semiconductor Devices", Bell Telephone Laboratories, Inc., NEEP Triannual Report.
6. K. G. McKay, "The n-p-n Junction as a Model for Secondary Photoconductivity", Physical Review, Vol. 84, No. 4, November 15, 1951.

PART VI - DIODES

DIODES

I. INTRODUCTION

The photosensitive nature of reversed biased semiconductor diodes has been investigated for a considerable length of time. Their susceptibility to ionizing radiation has made them suitable in many cases for applications as nuclear radiation detectors. It is for this reason, if no other, that semiconductor diodes are suspected to be a major contributor to circuit malfunctions in a pulsed radiation environment.

In this section, the general behavior of semiconductor diodes in a transient radiation field will be discussed together with an outline of the transient effect mechanism taking place within the device. Examples of typical transient radiation responses are given and a guideline is presented to aid in the selection of semiconductor diodes which are most radiation resistant.

II. SPATIAL DISTRIBUTION OF SENSITIVITY

Numerous observations have indicated the pulsed nuclear irradiations of forward biased diode junctions have little or no effect on the electrical characteristics of the device.^(1,2,3) Similar experiments conducted on reverse biased diodes show a sizeable decrease in junction resistance. Transient changes in the reverse biased leakage in the range of 10 μ a - 10 ma have been recorded for commercially available components. The magnitude of the changes depend largely upon the geometry of the diode junction.

The photoconductive and photovoltaic properties of p-n semiconductor junctions are understood in terms of the redistribution of electron-hole pairs produced by the ionizing radiation. It has been demonstrated that the observed transient photocurrents are the product of ionized carriers which lie within diffusion length of the rectifying junction. In a photocell experiment, Shive⁽⁴⁾ focused a narrow slit of light in the proximity of the semiconductor diode junction and found that the diode leakage current was a function of the distance of the light spot to the junction barrier. (See Figure 1)

In further experiments at the Sandia Pulsed Reactor Facility, Easley and Blair⁽⁵⁾ irradiated the entire diode to a gamma dose rate of 2×10^7 r/sec for approximately 50 μ s. They demonstrated that the observed transient currents were proportional to the product of the junction area and the diffusion length. In Figure 2, the peak leakage current normalized to the gamma dose rate is plotted against the effective generation volume of the test diode for a variety of geometries. The parameter f is a factor to compensate for the modulation of the diffusion length due to the associated neutron dose of the SPRF reactor. Deviations of the experimental points from the predicted values, (as indicated by the dotted line), are attributed to leakage effects on the surface of the device.

Calculations by Brown⁽⁶⁾, suggest that the bulk leakage current has two components. The first current arises from the production and diffusion of electron-hole pairs within a diffusion length of the diode junction. The time constant of this current is proportional to the minority carrier lifetime which is normally of the order of 10^{-5} to 10^{-7} seconds. An additional current is produced by electron-hole pairs generated within the space charge depletion region. Although the magnitude of the current is expected to be less than that of the diffusion current since w_{sc} , (the width of the space charge region), is less than L , (the diffusion length of the minority carriers), this current is characterized by considerably shorter rise times of the order of 10^{-9} to 10^{-10} seconds. This implies that for a burst of ionizing radiation of extremely short durations, i.e., 10^{-8} to 10^{-9} seconds, the two components should be separable. This hypothesis has achieved wide acceptance although experimental verification has not been reported.

Hence, the present physical model to account for the observed reversed biased leakage currents in a semiconductor diode suggest three current components. They are diffusion currents, space charge depletion layer currents and surface leakage currents.

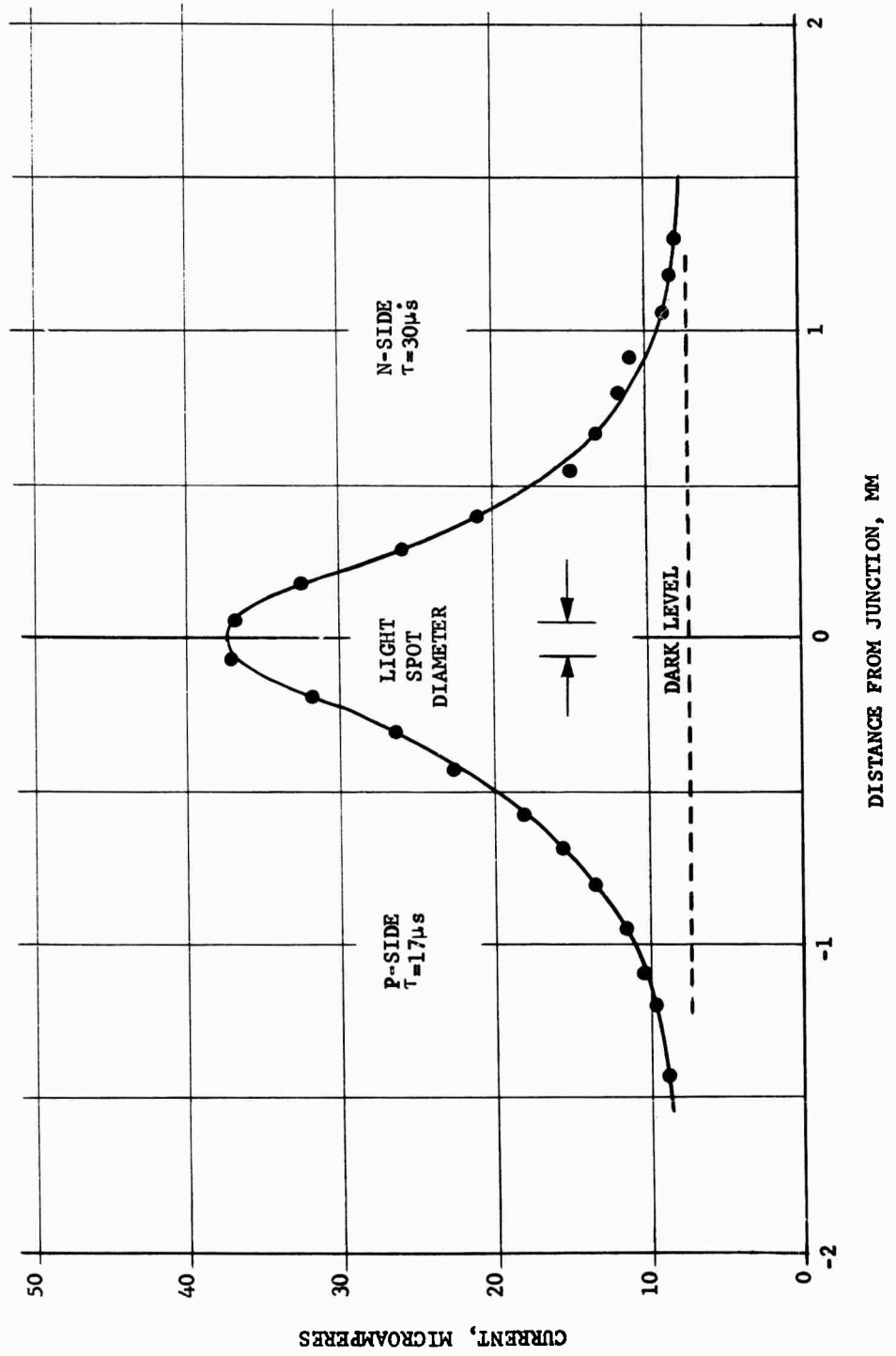

FIGURE 1: DEPENDENCE OF DIODE PHOTOCURRENT ON JUNCTION GEOMETRY

III. EQUIVALENT CIRCUIT REPRESENTATIONS

For the purpose of electrical circuit design the irradiated diode may be represented as shown in Figure 3. The diode is reversed biased with a voltage V_0 and is represented by a parallel junction resistance and capacitance, R_j and C_j ⁽⁷⁾. During irradiation, a current generator V_G and R_G is utilized to represent bulk photocurrents and a leakage resistance R_L represents surface leakages phenomena.

Values of R_j and C_j are functions of the individual diode characteristics available in device specification sheets and values of V_G , R_G and R_L are dependent on radiation dose rates, surface treatments and geometry of the diode under consideration.

IV. MATERIALS AND DEVICE TYPES

Due to the larger forbidden energy gap in Silicon, ($E_c - E_v = 1\text{ev}$), than in Germanium, ($E_c - E_v = .65\text{ ev}$), it is expected that Silicon diodes are more impervious to transient radiation effects, for similar device geometries.

In addition, high speed switching diodes perform considerably better in an ionizing environment than the larger junction power diodes⁽²⁾. Zener diodes exhibit very small responses to transient gamma irradiations.

Tunnel diodes appear to be relatively insensitive to transient radiation effects. Their performance is so high that they are utilized in test circuitry which operates in pulsed nuclear radiation environments.

The radiation resistance of tunnel diodes is attributed to three distinctive features of this type of device. These features are; (a) the tunneling of majority carriers as a means of current flow, (transient currents in other types of diodes are attributed to minority carrier flow), (b) narrow junction depletion region, (which minimizes any existing minority carrier flow), and (c) low device impedances which minimize the effect of any existing surface leakage effects.⁽¹⁾

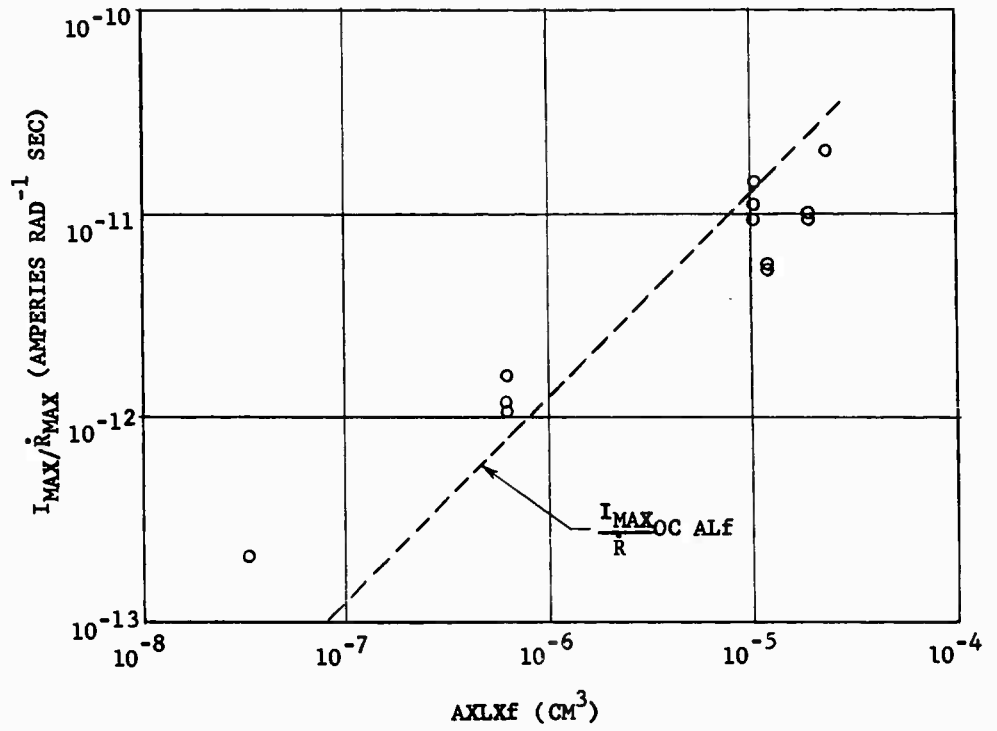

FIGURE 2: NORMALIZED LEAKAGE CURRENT AS A JUNCTION OF EFFECTIVE JUNCTION VOLUME

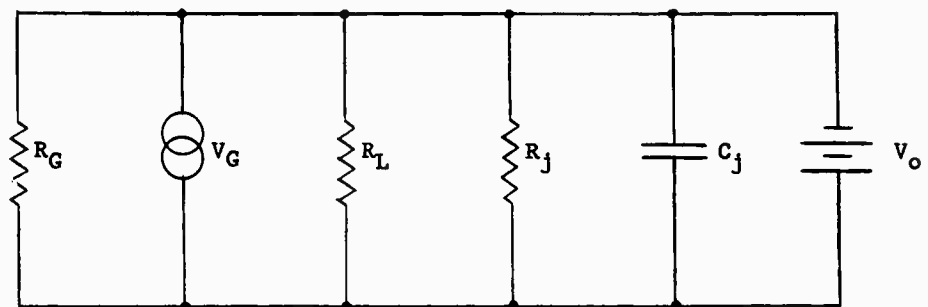
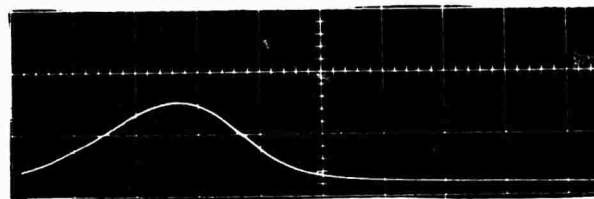
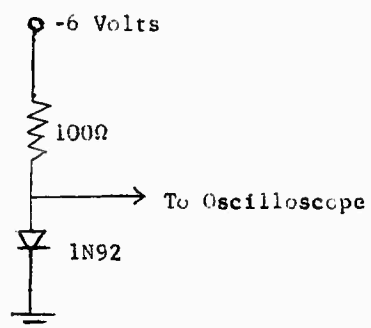

Figure 3. Equivalent Circuit for Reversed Biased Diode During Transient Irradiation.



Horizontal Sweep - 20 μ s/cm
Vertical Sensitivity - 20 ma/cm

FIGURE 4: TYPICAL RESPONSE OF 1N92 TO SPRF RADIATION BURST
PEAK RADIATION DOSE RATE $\dot{\gamma} = \sim 2 \cdot 10^7$ r/sec

V. EXPERIMENTAL OBSERVATIONS

Transient responses in reversed biased diodes are proportional to the gamma dose rate incident upon the device. Figure 4 shows the response of a 1N92 diode to the 50 μ s pulse of gamma radiation from the Sandia Pulsed Reactor Facility (SPRF). The reliability with which the variations in leakage current represent the gamma dose rate has led to their adoption as nuclear radiation detectors.

VI. SUMMARY

The lack of statistical data on a large variety of specific diode type prohibits the enumeration of their expected sensitivities to a pulsed ionizing radiation. However, as the result of investigations that have been made hithertofore, the following generalizations may be made about the relative susceptibility of commercially available semiconductor diodes:

1. Reverse bias diodes are extremely sensitive to transient radiation effects. Forward bias diodes show little or no effect to the same environment.
2. The magnitude of the induced transients are proportional to the product of the junction area and the diffusion length of the device. Hence, power diodes are more likely to induce circuit malfunctions than the higher speed switching diodes.
3. Surface leakage effects are also present during the radiation burst. These effects are minimized in lower impedance devices.
4. The radiation induced transient changes in a diode may be represented as a current generator and leakage resistance across the terminals of the diode.
5. Zener diodes indicate small changes in the back biased resistance and tunnel diodes are virtually impervious to transient radiation environments of practical interest.
6. For devices of similar electrical characteristics and geometry, Silicon diodes are to be preferred over Germanium diodes.

Semiconducting diodes are perhaps the most radiation sensitive of all commonly used circuit components. Numerous circuit malfunctions in transient radiation environments have been traced to large leakage currents produced by these devices. A realistic appraisal of the radiation resistant qualities of a system or subsystem can best be estimated by considering the circuit context in which these devices are placed. A satisfactory quantitative estimate of the magnitude of these effects, of course, can be made only through test irradiations of the individual components and circuits in which they are placed.

REFERENCES

1. Bray, C. W., "Nuclear Pulse Radiation Test on Zener Diodes and Minute-man Components and Circuits using the Triga Mark F Reactor of General Atomic", General Atomic, 8 August 1962.
2. Jones, D. C. et al, "Transient Radiation Effects on Electronic Components and Semiconductor Devices", REIC Report No. 26, Battelle Memorial Institute, 19 April 1963.
3. Perkins, C. W., et al, "Third Experiment on Pulsed Neutron Radiation Effects", Hughes Aircraft Company, T. M. No. 623, October 1959.
4. Shive, "Properties of the M-1740 P-N Junction Photocell", Proc. of IRE, Vol. 40, No. 11, November 1952.
5. Easley and Blair, "Transient Phenomena in Semiconductor Devices", Bell Telephone Laboratories Tri-Annual Report, Appendix E.
6. Brown, "Transient Effects of High Intensity Radiation in P-N Junctions", Bell Telephone Laboratories Tri-Annual Report, Appendix D.
7. McKay, "Electron-Hole Production in Germanium by Alpha-Particles, Phys. Rev. Vol. 84, No. 4., 15 November 1951.
8. Russell, R. L., "The Tunnel Diode as an Active Element in Radiation Hardened Circuits", Hughes Aircraft Company. (unpublished)

PART VII
TRANSIENT GAMMA RADIATION EFFECTS
ON MICROELECTRONIC CIRCUITRY

TRANSIENT GAMMA RADIATION EFFECTS
ON MICROELECTRONIC CIRCUITRY

INTRODUCTION

The future potential of microelectronic circuitry appears limitless with the present rate of increase in reliability and improved fabrication techniques. The incorporation of microelectronics not only greatly eases the problems of packaging, but also simplifies the processes of troubleshooting and maintenance. The effects of transient radiation on microelectronics is, at present, not well known mainly because of the short period of time on the commercial market. Tests performed by the Nucleonics Research Department, however, have fortunately enabled the formulation of sufficient preliminary data to be of use to designers planning to incorporate the use of microelectronic circuits.

GENERAL DISCUSSION

The field of microelectronics is divided into two groups distinguished by the method of fabrication. A brief and general discussion is felt necessary to assure the general understanding of nomenclature used.

A. Bulk Semiconductor Circuitry

The general sequence of fabricating bulk semiconductor circuits starts with a semiconductor substrate usually of P-type material. Through alternating processes of passivation, diffusion, and photo-etching, a complete circuit can be fabricated which contains transistors, resistors, capacitors and diodes all formed of semiconductor materials. Figure 1(a) describes the cross-section of a bulk semiconductor circuit with the equivalent circuit shown in 1(b).

As can be seen in Figure 1(b), the semiconductor substrate acts as an isolation diode between each component and ground, therefore, this effective diode must be reverse biased for proper operation of the circuit. Past experience from radiation effects tests predicts that the reverse biased isolation diode will cause these circuits to be more radiation sensitive than if the substrate were made of low conductivity insulating material.

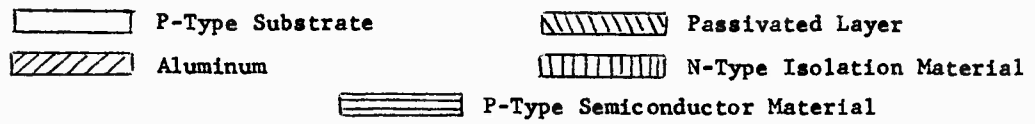
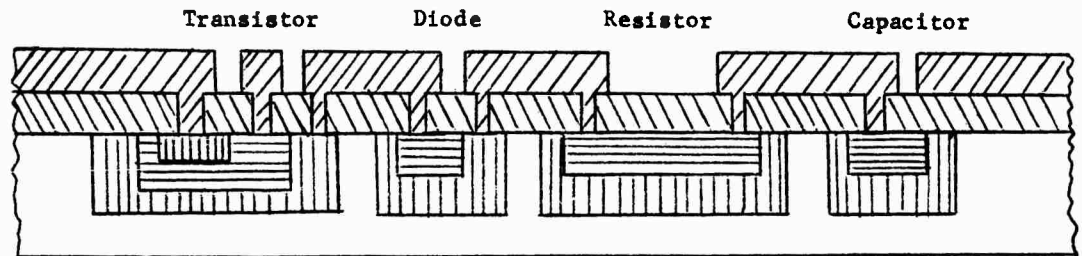

(a)

Crosssection of Typical Bulk Semiconductor Circuit

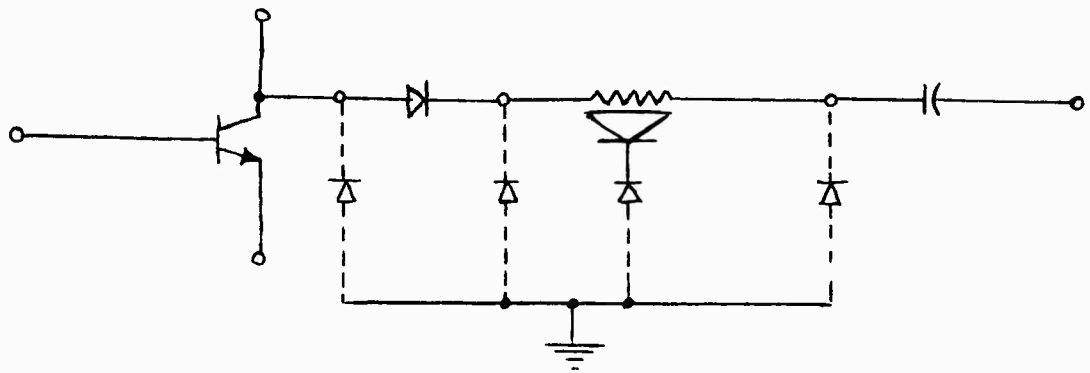

(b)

Equivalent Circuit Including Substrate Isolation Diode

FIGURE 1: BULK SEMICONDUCTOR CIRCUIT

B. Thin Film Hybrid Circuits

The thin film circuits start with a substrate made of glass and through alternating processes of diffusion, etching, and oxidation, passive components are formed. As yet, active components are not being formed by the thin film process, so transistor and diode clips are attached to the thin film circuit by standard methods. Figure 2(a) shows a thin film circuit with the equivalent circuit in Figure 2(b).

This method of fabrication does not result in an isolation diode between components and ground, so it is expected this circuit will be less sensitive to radiation than the bulk semiconductor circuit.

COMPARISON OF RADIATION EFFECTS

Passive and active components resultant of the two methods of fabrication will respond differently during a radiation pulse and the relative responses will be discussed.

A. Resistors

1. Bulk Semiconductor resistor is shown in Figure 3(a) where R is the nominal resistance of the resistor and R_1 is the radiation induced shunt leakage due to ionization of the surrounding material and air. The current generator I represents the injected current induced by the radiation pulse. Diode D1 is formed between the P-type resistor material and the N-type isolation material and Diode D2 is formed by the N-type isolation material and P-type substrate material. Figure 3(b) indicates the resistor response during irradiation when monitored in the circuit of Figure 3(a). The response is a negative current pulse with a magnitude which is a non-linear function of the voltage across the resistor. This response has been characteristic of all tests to date on bulk semiconductor resistors.

2. Thin Film Resistors

The equivalent circuit for thin film resistors is shown in Figure 4(a) where R, R_1 and I represent the same as in Figure 3(a). The main difference in this resistor is the absence of the diodes as compared to the bulk semiconductor resistor. Figure 4(b) shows the response of this resistor during irradiation, when monitored in the test circuit of

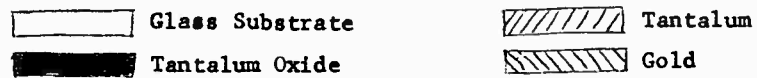
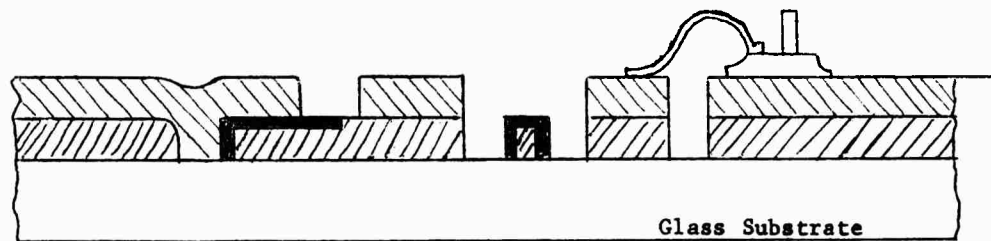
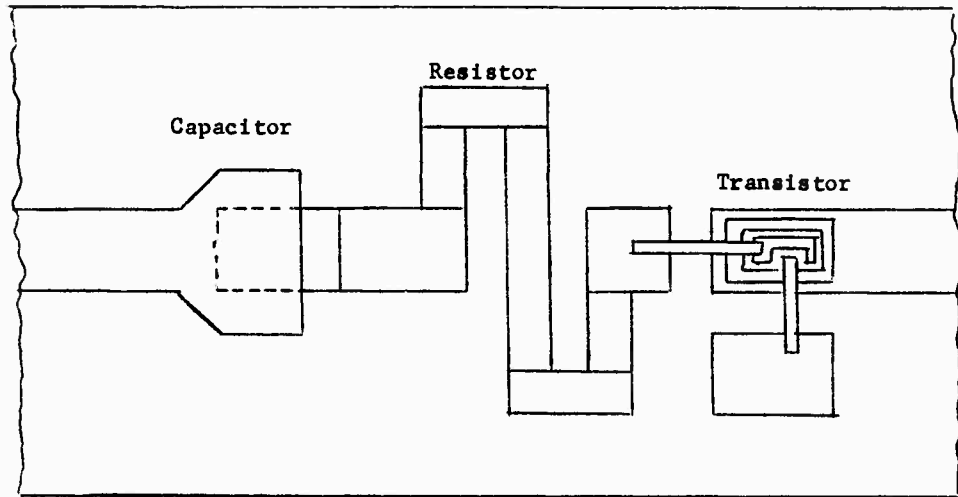

(a)

Typical Thin Film Hybrid Circuit Construction

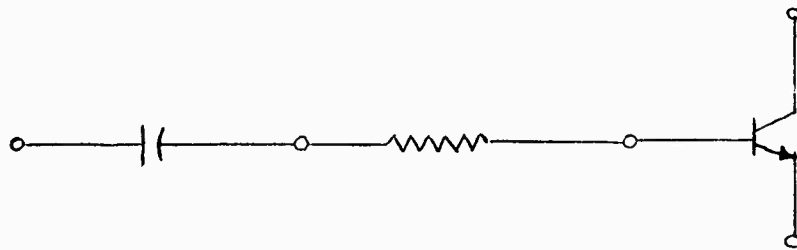

(b)

Equivalent Circuit

FIGURE 2: THIN FILM HYBRID CIRCUIT

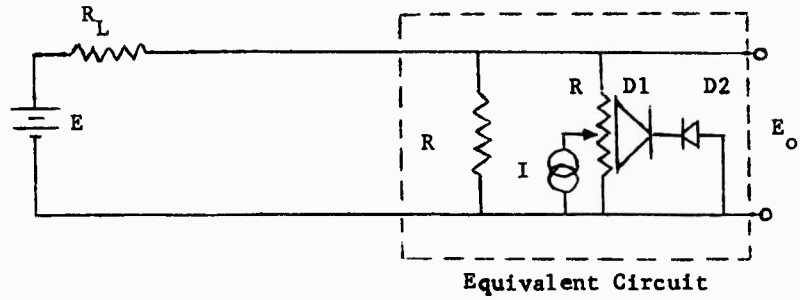

(a)

Test Circuit and Equivalent of Bulk Semiconductor Resistor

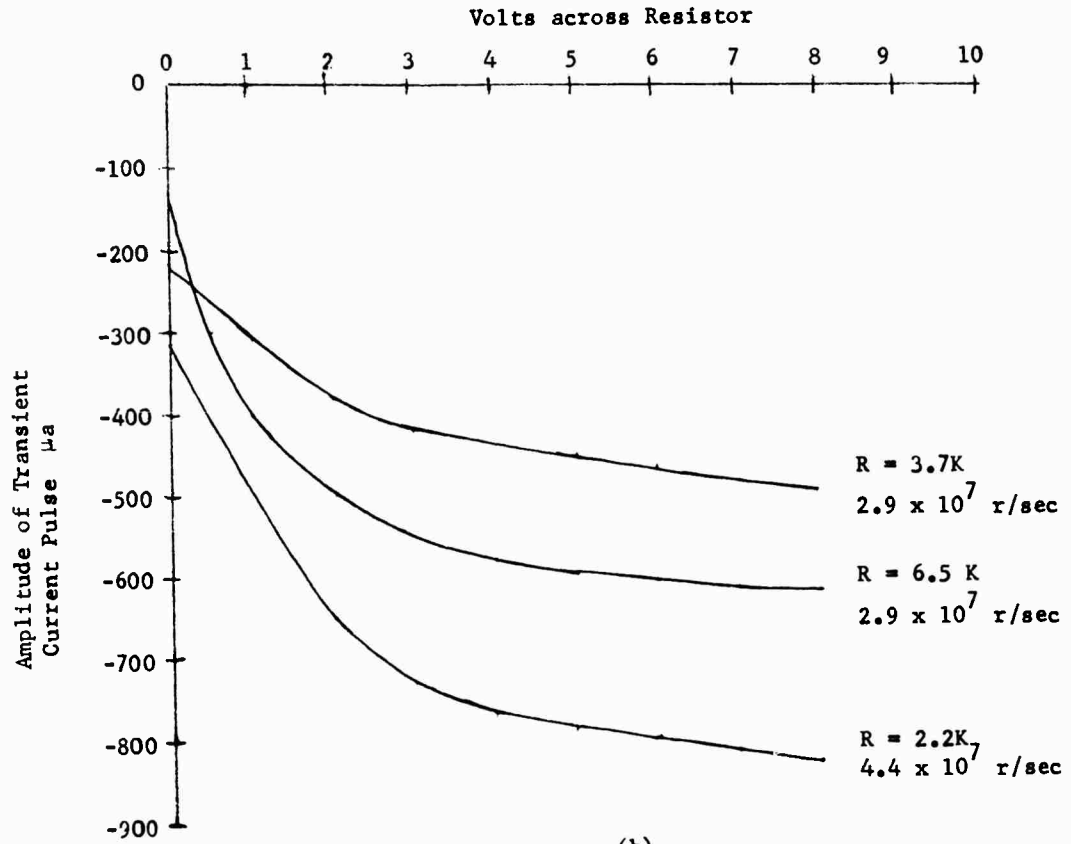

(b)

Radiation Response of Bulk Semiconductor Resistor

FIGURE 3: BULK SEMICONDUCTOR RESISTOR

Figure 4(a). The response is a negative current pulse whose amplitude is a linear function of the voltage across the resistor. The intersection of the response curve with the ordinate indicates the value of the injected current I . All tests to date on thin film resistors indicate the same response with the ordinate crossing apparently a function of the resistor potting material.

B. CAPACITORS

1. Bulk Semiconductor Capacitors

Until recently, bulk semiconductor capacitors have been unavailable for testing, therefore, no data is available. However, from experience with the bulk resistor, it is expected the capacitor will respond to irradiation with a non-linear relationship to the voltage across the capacitor. Data should be available soon.

2. Thin Film Capacitors

The equivalent circuit for thin film capacitors is shown in Figure 5(a), where R_1 and I represent the same as in Figure 3(a). The capacitance C is the nominal value of the capacitor. The response of this component during irradiation is shown in Figure 5(b), and is characterized by a negative current pulse, whose amplitude is a function of the voltage across the capacitor. The ordinate intersection once again is a function of the potting material. The circuit used for the test is indicated in Figure 5(a).

C. DIODES

1. Bulk Semiconductor Diodes

The equivalent circuit for bulk semiconductor diodes is shown in Figure 6(a) and response to irradiation is shown in Figure 6(b). The responses have been separated to that due to the isolation diode and that due to the diode itself. The total response combining the two diode effects is expected to be nearly the sum of the two separate responses.

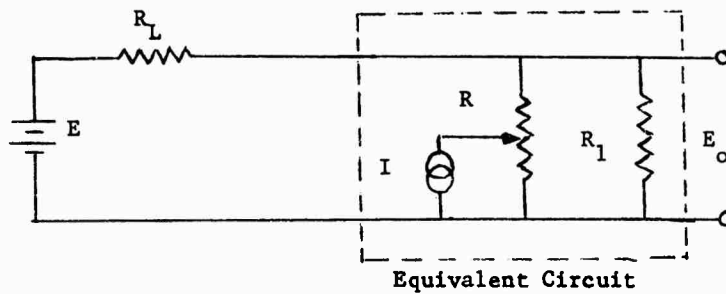

(a)

Test Circuit and Equivalent Circuit of Thin Film Resistor

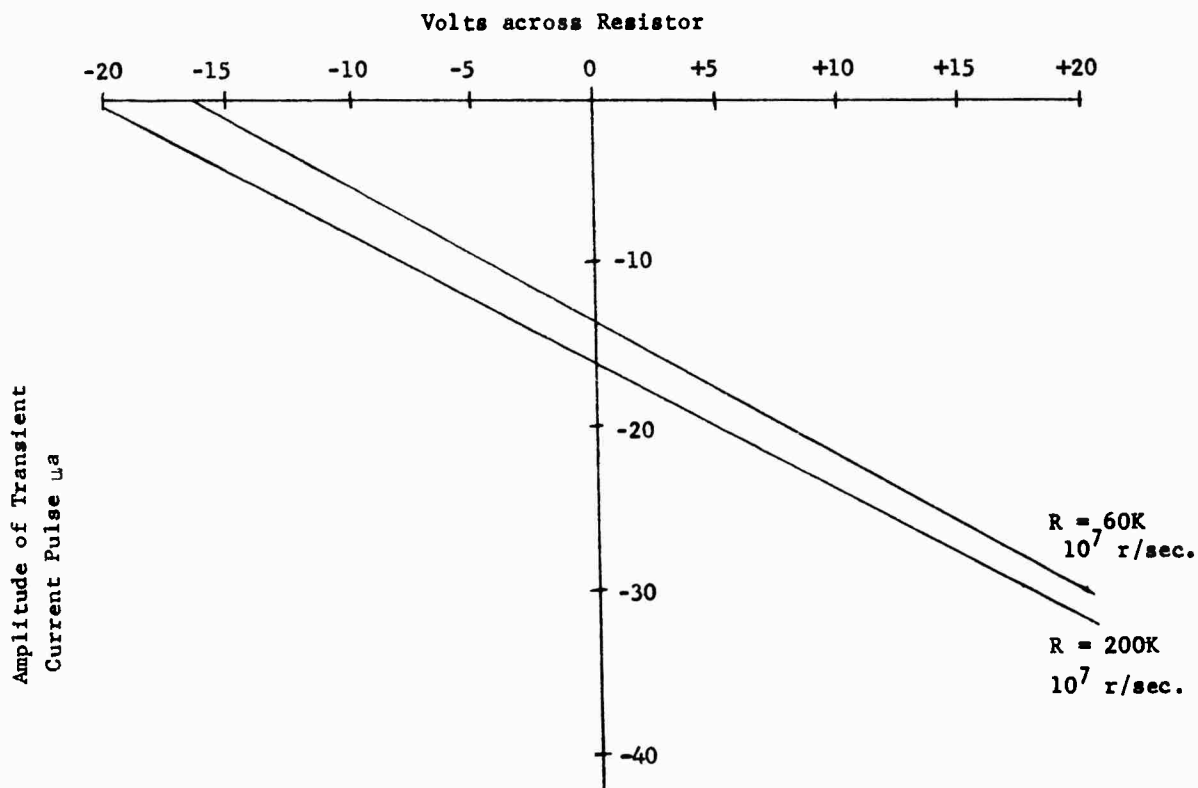

(b)

Radiation Response of Thin Film Resistor

FIGURE 4: THIN FILM RESISTOR

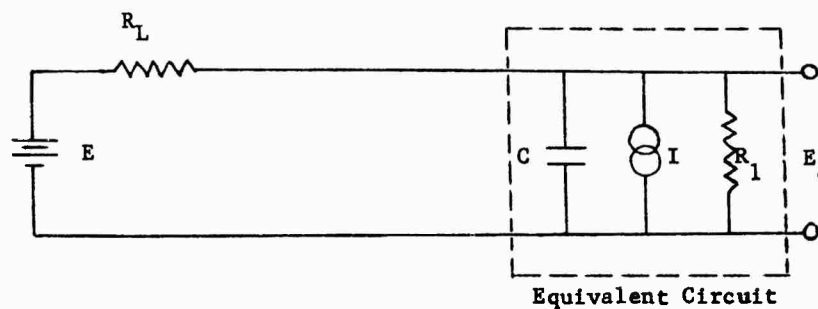

(a)
 Test Circuit and Equivalent Circuit of Thin Film Capacitor

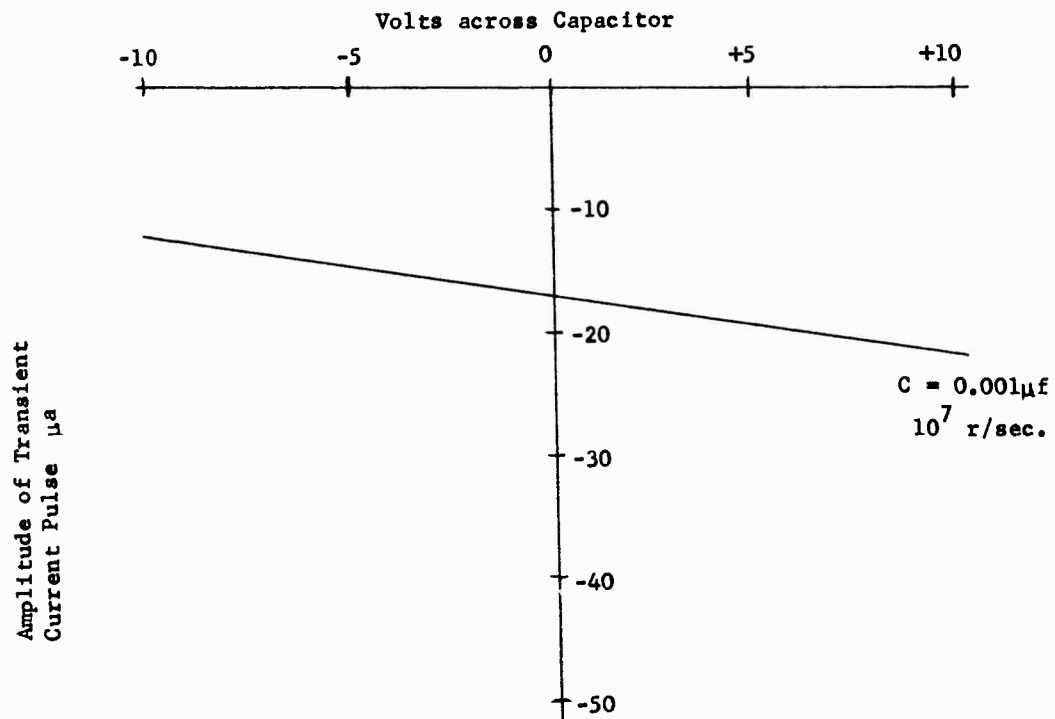

(b)
 Radiation Response of Thin Film Capacitor

FIGURE 5: THIN FILM CAPACITOR

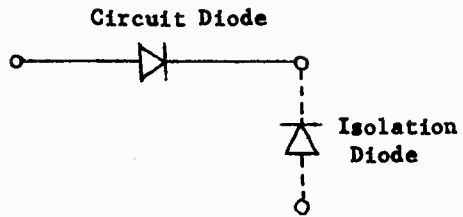

(a)

Equivalent Circuit for Bulk Semiconductor Diode

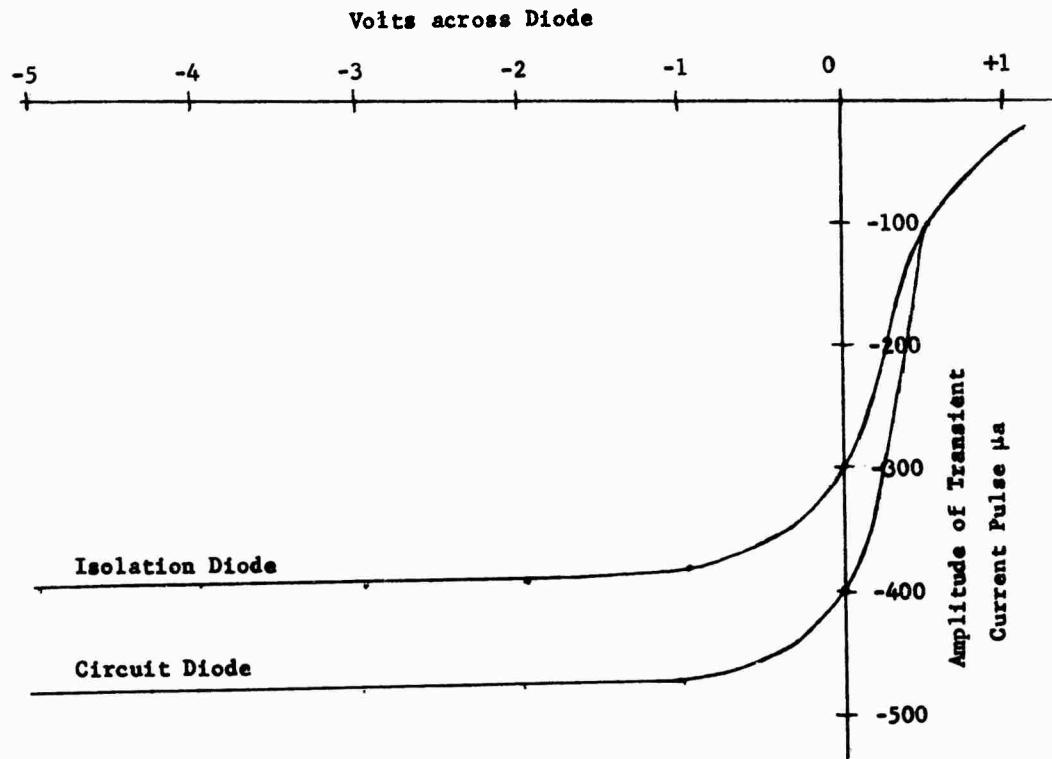

(b)

Radiation Effects of Bulk Semiconductor Diode

FIGURE 6: BULK SEMICONDUCTOR DIODE

2. Thin Film Diodes

Since the active components for thin film circuits are actually the standard components, the response for these diodes will be omitted here to be found in the report covering diodes.

D. TRANSISTORS

Bulk semiconductor transistors have not been tested as components to date, because of unavailability; however, when tested in circuits the general response has been the same as for transistors used in thin film circuits, except the magnitude of the responses have been approximately one order of magnitude greater. Because of the effective isolation diode in the bulk semiconductor circuits, it is expected the component response of the transistor will be greatly different than the transistor used in thin film devices.

CONCLUSIONS

From the tests performed and the data available, it is concluded that for a given application, a thin film circuit will be less sensitive to radiation than the bulk semiconductor circuit by at least one order of magnitude.

REFERENCES

The information presented in this document was extracted from the following Hughes Aircraft Company Reports:

1. FR 63-17-42
"Transient Radiation Effects on Bulk Semiconductor Devices and Thin Film Devices", by E. P. Mitchell and J. E. Bell.
2. FR 63-17-52
"Special Report - Radiation Effects on Microelectronic Devices", by E. P. Mitchell, R. W. Marshall and J. E. Bell.
3. FR 62-17-36
"Transient Radiation Effects on Thin Film Devices", by, C. W. Perkins.

PART VIII
TRANSIENT GAMMA RADIATION EFFECTS
ON I-R DETECTORS

TRANSIENT GAMMA RADIATION EFFECTS
ON I-R DETECTORS

Infrared detectors of the photoconductive type show two effects when subjected to pulsed nuclear radiation: a sharp decrease in resistance and an effective induced current. These two effects change the current through the detector and, hence, the voltage across its load resistor which might be erroneously interpreted by the system as an infrared signal. Figure 1 shows an infrared detector and its load resistor, two biasing power supplies, and an equivalent "voltage plane". The dotted lines show the induced current generator and equivalent parallel resistance due to nuclear radiation. The induced current generator is a result of charge scattering. A net negative charge is absorbed by the detector during radiation. This absorption takes place in the detector leads and throughout the volume of the device and is assumed to be injected into the center of the device by current generator I , as shown in Figure 1.

The parallel resistance is due to hole-electron pair production in the detector element and in the substrate material on which it is mounted. It is also due to radiation induced ionization of air surrounding the detector element which can carry current around the device. These current paths are shown by R_p , R_2 , and R_1 in Figure 1. R_p is the parallel resistance across the device, R_2 is the leakage resistance from the signal lead to any ground planes that might be present, such as the chassis or ground leads. R_1 is the leakage resistance to any nearby wires other than ground, such as power supply lines that might act as equivalent "voltage planes".

Tests were run to determine the relative effect of I , R_p , R_1 and R_2 on the response of the detector to radiation. Leakage current through R_2 can be reduced by adjusting the power supplies E_1 and E_2 so that the d.c. signal lead voltage at node V_1 on Figure 1 is zero volts, while keeping the required bias across the detector for maximum detector sensitivity. R_p is determined by the slope of the plot of detector current pulse versus detector voltage, while keeping V_1 and E_3 constant ($V_1 = 0$ in this case), as shown in Figure 2.

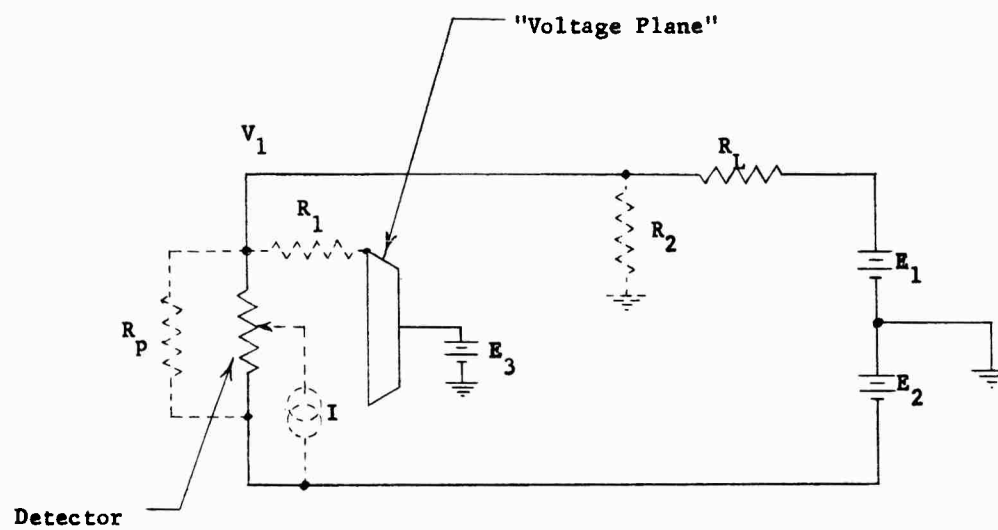

FIGURE 1 INDUCED CURRENT AND LEAKAGE RESISTANCES OF AN INFRARED DETECTOR DUE TO TRANSIENT NUCLEAR RADIATION.

The R_p in this case is 0.8 megohms. The injected current is twice the value indicated by the intercept of this plot with the current pulse axis or 190 μ amps.

R_1 is determined by the slope of the plot of current pulse versus a simulated "voltage plane" (voltage E_3) keeping V_1 , E_1 and E_2 constant. Figure 3 shows R_1 to be 0.8 megohms. Note that for positive values of E_3 the leakage resistor R_1 carries current toward the detector's signal lead and tends to offset the current pulse associated with R_2 , R_p and I . For 40 volts applied potential on the "voltage plane", the current pulses due to radiation (see Figure 1) exactly cancel each other in this particular case, and the circuit sees no effect of radiation.

Infrared detectors that have a characteristic time constant much longer than the rise and/or fall time of the radiation pulse cannot be handled in this manner to limit their response to radiation. The "voltage plane", as described above, can be used near the detector to limit the transient response of the detectors to nuclear radiation. This technique is useful only when the infrared detector has a characteristic time constant equal to or less than the rise and/or fall time of the nuclear radiation pulse.

A lead selenide detector cooled to -196°C with a field of view of 53 degrees and optical passband from 3.3 to 4.8 microns was tested. This detector normally has a characteristic time constant of 100 to 200 microseconds. The time constant exhibited by this detector following an applied pulse of nuclear radiation was 26 microseconds. Infrared detectors generally exhibit a shorter time constant when subjected to an intense flash of infrared radiation that saturates the detector. This probably explains why the time constant is shortened and also indicates that the nuclear radiation saturates the detector. Extrapolating the tail of the detector response back to the time when radiation is present indicates that the detector changes its resistance by 88%, when subjected to nuclear radiation. This also indicates the detector is in a saturated state. This change in resistance is orders of magnitude larger than any change in resistance one would expect from any infrared source under normal operating conditions.

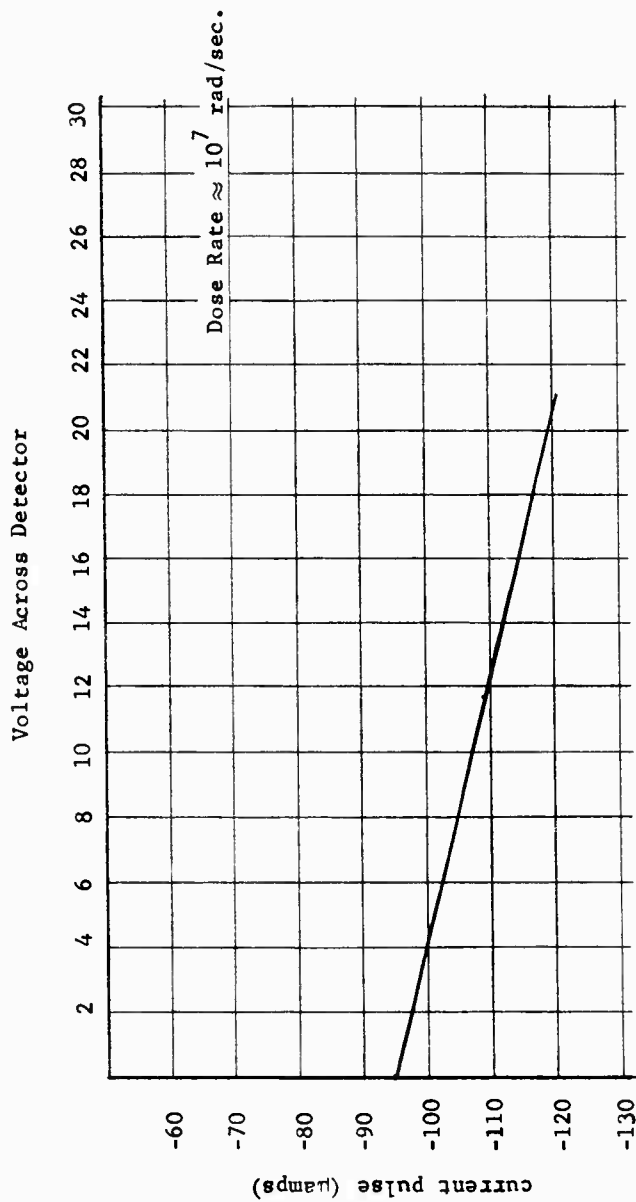

FIGURE 2 GRAPH OF APPLIED VOLTAGE VERSUS RADIATION INDUCED CURRENT PULSE FOR A LEAD SELENIDE INFRARED DETECTOR

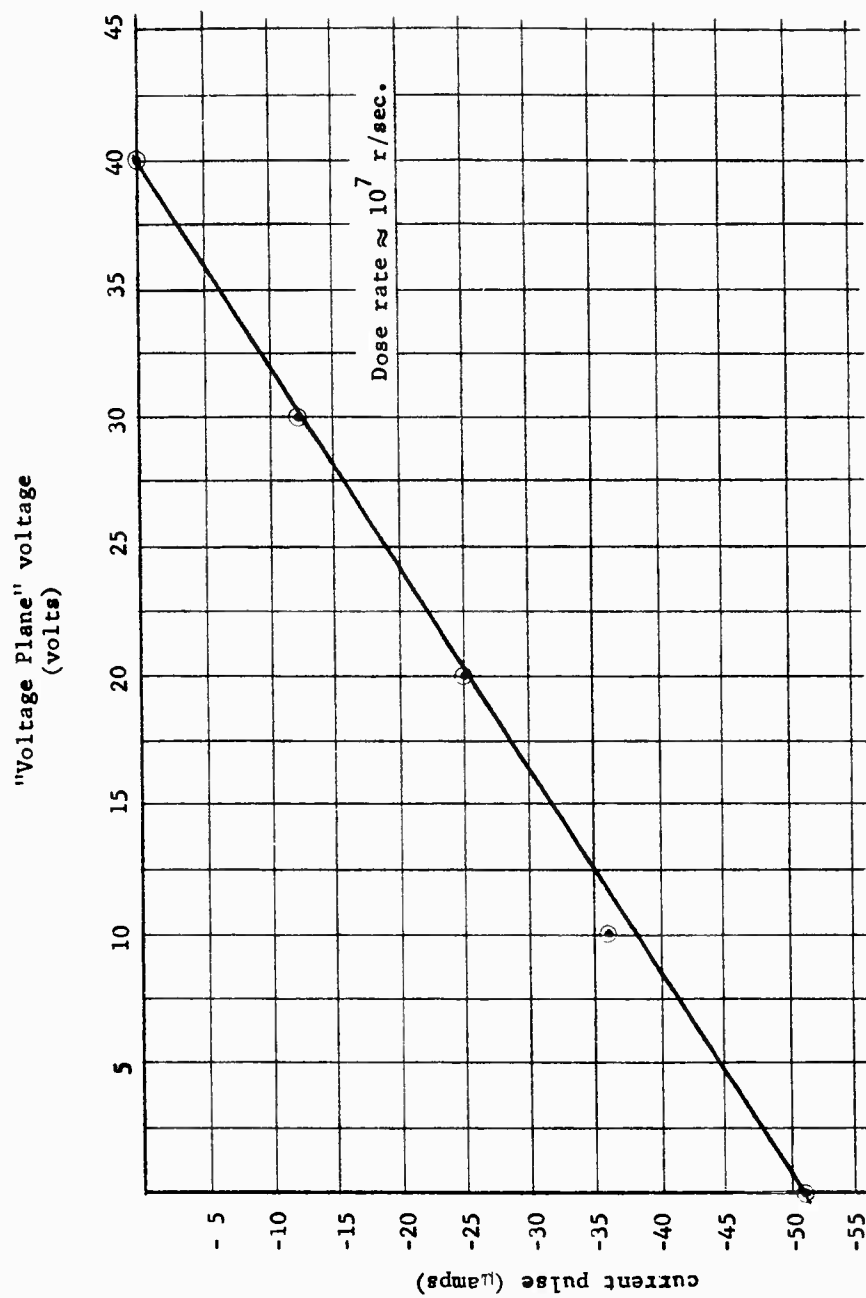

FIGURE 3 GRAPH OF DETECTOR CURRENT PULSE VERSUS "VOLTAGE PLANE" VOLTAGE FOR A LEAD TELLURIDE INFRARED DETECTOR.

The actual effect of transient radiation on an infrared system will depend on the configuration in which the detector is used. Detectors are usually high resistance types and load resistors of high values are used to insure maximum power transfer; hence, detector current changes of small values will cause significant voltage changes across the large load resistors. Detectors used with light choppers are generally used with narrow bandpass amplifiers which will limit the transient response due to radiation. The effect of radiation on detectors used with wideband amplifiers will depend on the final use of the detector signal.

PART IX
TRANSIENT RADIATION EFFECTS
ON SILICON CONTROLLED RECTIFIERS (SCR)

TRANSIENT RADIATION EFFECTS
ON SILICON CONTROLLED RECTIFIERS (SCR)

An SCR is a solid state semiconductor device composed of four layers of alternate impurity semiconductor material (PNPN) having a gate, anode and cathode.

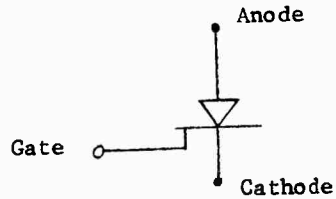

The SCR is an active switching element with characteristics similar to those of a gas thyatron, that is, it will remain in a non-conducting or "off" state until turned on or "fired" by a low level control signal on the gate. It will then remain "on" without the need for a sustaining control signal. The SCR is turned "off" by reducing its anode current to below the "dropout" level. The operation of an SCR or PNPN structure can best be understood by considering the SCR to consist of a PNP and an NPN transistor with a common collector junction.

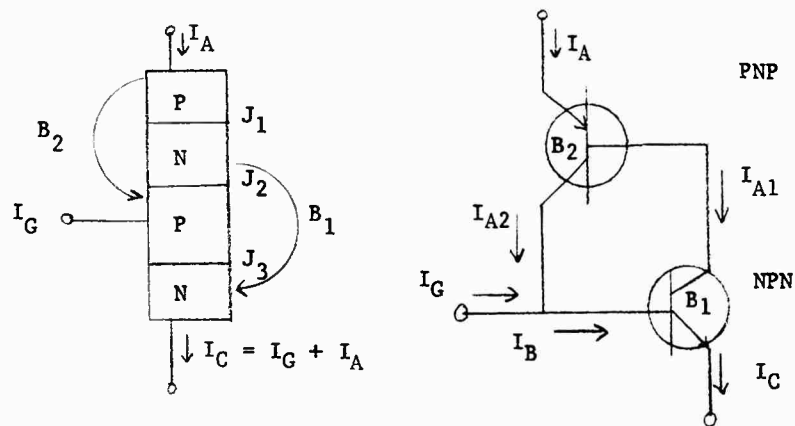

An SCR operates as follows: The collector of the NPN drives the base of the PNP and the collector of the PNP drives the base of the NPN. This positive feedback loop has a gain equal to $B_1 \times B_2$, the product of the current gains of the two transistors. The circuit is stable as long as $B_1 \times B_2$ is less than unity, but becomes self-regenerative when the loop gain approaches unity. Thus, can be shown clearly by solving for I_A in terms of B_1 , B_2 , I_G , I_{CO1} , and I_{CO2} .

$$\text{if } I_{A1} = B_1 (I_{CO1} + I_B) + I_{CO1}$$

$$\text{and } I_B = (I_G + I_{A2})$$

$$(1) I_{A1} = B_1 (I_{CO1} + I_G + I_{A2}) + I_{CO1}$$

$$\text{if } I_{A2} = B_2 (I_{A1} + I_{CO2}) + I_{CO2}$$

$$\text{and } I_{A1} = (I_A - I_{A2})$$

$$\text{then } I_{A2} = B_2 (I_A - I_{A2} + I_{CO2}) + I_{CO2}$$

Solving for I_{A2}

$$(2) I_{A2} = \frac{B_2 I_A}{1 + B_2} + I_{CO2}$$

$$\text{if } I_A = (I_{A1} + I_{A2})$$

$$\text{or } I_{A2} = I_A - I_{A1}$$

$$\text{than } (I_A - I_{A1}) = B_2 (I_{A1} + I_{CO2}) + I_{CO2}$$

Solving for I_{A1}

$$(3) I_{A1} = \frac{I_A}{1 + B_2} - I_{CO2}$$

Inserting the values for I_{A2} and I_{A1} from equations (2) and (3) into equation

(1) and solving I_A gives:

$$I_A = \frac{(1 + B_2) [B_1 (I_G + I_{CO1} + I_{CO2}) + I_{CO1} + I_{CO2}]}{1 - B_1 B_2}$$

It can clearly be seen that when $B_1 \times B_2 \rightarrow 1$, $I_A \rightarrow \infty$, and the SCR will turn "on" with the current through the device limited by the external load.

When a high-energy short duration gamma ray radiation pulse impinges upon an SCR circuit, the following effects occur:

1. Ionization produced in normal insulating regions in the SCR produces internal leakage, as ionization creates electron-hole pairs in large excess.
2. Ionization of the surrounding air causes external leakage from one electrode to another.
3. Scatterling of charge from the component such as photoelectric or Compton scattering causes extraneous currents to flow in the external circuitry in a manner equivalent to that with a current generator connected from some point in the component to ground.

Any increase in current due to a radiation dose rate will cause an increase in I_A which in turn will increase B_1 and B_2 . If the radiation dose rate is large enough $B_1 \times B_2$ will approach unity and eventually turn the device "on".

Experiments were performed on the Hughes Research Linac to determine the gamma ray dose rate and integrated dose required to switch the following SCR circuit into conduction.

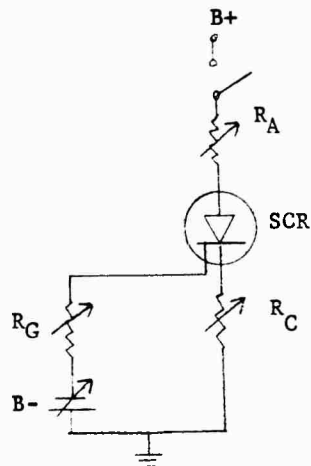

The experiment was designed to determine the effect of each of the above circuit parameter changes on the radiation dose rate required to switch the circuit into conduction. The Linac pulse width was held constant while the Linac beam current was increased until the SCR circuit switched into conduction. This point was designated as the threshold of the circuit configuration for a specific pulse width and beam current. The following curve shows the switching thresholds for the 2N892 SCR with the following circuit parameters:

$B+$ = 10V
 R_A = 100 ohm
 R_C = 0
 R_G = 1K
 $B-$ = 0

2N892 SCR Switching Thresholds

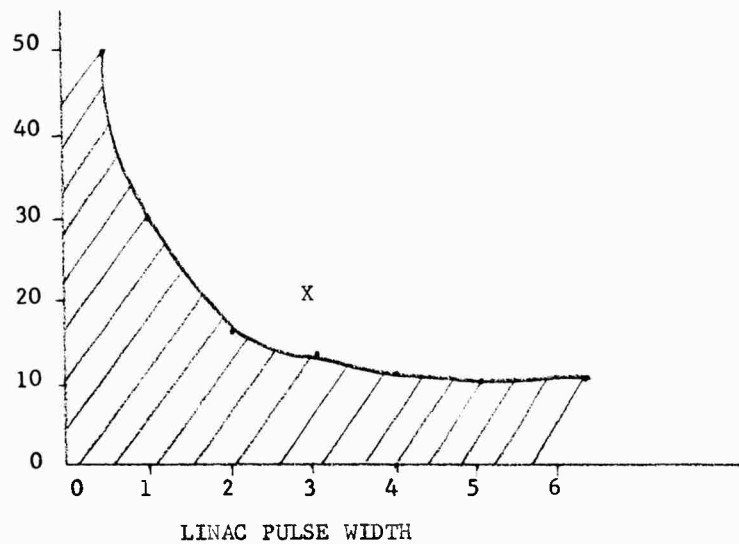

The above curve shows that the SCR circuit will switch "on" and remain "on" whenever the circuit encounters a radiation dose rate and radiation pulse widths in the unshaded area of the curve. For example, a radiation pulse of 2×10^7 R/sec and 3 μ s wide (indicated on the curve as X) will definitely switch the given SCR circuit "on". You will notice that as the radiation pulse increases in width that the dose rate required to switch the SCR becomes constant. As the pulse width approaches zero, the dose rate required to switch the SCR increases rapidly. This means that an SCR is not as susceptible to radiation at very narrow pulse widths than at pulse widths greater than 3 MS.

Similar curves were drawn for many different circuit configurations and the following conclusions were obtained:

1. A negative gate bias makes an SCR less sensitive to switching due to a radiation environment if R_G is less than 1K, as the gate resistance increases ($R_G > 1K$) the negative gate bias has no effect.
2. Placing the load in the anode circuit rather than the cathode circuit slightly decreases the radiation induced switching sensitivity.
3. The value of the load resistor has little, if any, effect on the switching sensitivity. As long as the circuit can conduct enough holding current, it will switch due to a specific radiation dose and dose rate.

PART X
A SURVEY OF TRANSIENT GAMMA
RADIATION EFFECTS ON AMPLIFIERS

A SURVEY OF TRANSIENT GAMMA
RADIATION EFFECTS ON AMPLIFIERS

Transient gamma radiation affects electronic circuitry by generating ionized regions in and about circuit components and circuit conductors. These ionized regions, over which small currents can pass, act to momentarily redistribute circuit charge. This redistribution of circuit charge may cause the circuitry to temporarily malfunction.

The transient radiation effects on amplifiers were investigated by subjecting whole amplifier circuits and portions of amplifier circuits to gamma radiation pulses, while monitoring the amplifier outputs. Both vacuum-tube type and transistor type amplifiers were studied.

Figures 1 through 4 depict the schematic diagrams of the amplifiers tested. In some of the experiments an acrylic spray was used in an attempt to limit the radiation induced effects. (Ref. 1)

In Figure 1 a two stage transistor amplifier is shown. Various portions of this circuit were irradiated to determine the radiation sensitive areas. (Ref. 2) Experimentation revealed that the areas of the input transistor and diode and the output transistor were most sensitive. The input transistor Q1, diode CR1, and output transistor Q2 were irradiated individually and together. Figure 5 shows transient responses observed. The difference between curves C and D in Figure 5 is attributed to a transient 30% degradation in gain of the circuit. This degradation in gain attained its largest value during the radiation interval and recovered relatively slowly. The time of recovery was not measured. The wave shapes and amplitudes of these transient responses vary with the components used for a given circuit. These differences are the result of variations in the parameters of specified components. In general the transient responses of the amplifier attained a final peak value and recovered with the RC time constants of the circuit.

Figures 2 through 4 give the circuit diagrams of the three single-stage amplifiers tested. (Ref. 1) Two circuits are of the vacuum-tube type, and

one is a transistor circuit. One of each amplifier was sprayed with an acrylic insulating coating. Radiation tests were performed on both the sprayed and unsprayed amplifiers. During the tests a 1 mcs. r.f. signal was supplied to the amplifier inputs. Measurements were made with the amplifiers in and out of the radiation field, with and without the B+ applied. The contributions to the output transient, when the circuit was not in operation, were small in comparison with those observed when the circuit was in operation. In general, the amplifiers displayed a prompt output pulse, followed by a relatively long RC decay term. The only exception to this was the sprayed transistor circuit. In this case the output pulse continued to increase markedly during the radiation interval to a peak value and then recovered with a large RC time constant. (See Figure 6)

An improvement in the reduction of the net output pulse amplitude was noted for the sprayed vacuum-tube circuits. Comparison of the net output pulse amplitude, when the circuits were in operation, revealed that spraying of the circuits resulted in amplitude reductions of 25 percent to 50 percent. In contrast to this the transistor circuit exhibited a 200 percent increase in its peak values. The cause of this increase is attributed to the sensitivity of the transistor to secondary emission.

In conclusion experimentation has shown that the most sensitive areas in transistor amplifier circuits are in the regions of the active devices. Vacuum-tube circuits sprayed with an acrylic insulating material exhibited a substantial reduction in the net pulse amplitudes. This is attributed to a reduction in available air leakage paths. However, this coating technique failed to produce favorable results for transistor circuits, the considerable increase in the peak amplitude values being attributed to secondary emission in the coating.

REFERENCES

1. Perkins, C. W., Rogenfeld, J., Smith, D. B., Wieneke, J. R., "First Experiment on the Effects of Radiation Pulses on Electronic Circuits and Components", Hughes Aircraft Company, Technical Memorandum No. 506, 3 February 1958.
2. Eaton, M. S., Helms, R.L., Pizarek, R. H., Bell, J. E., "Transient Radiation Effects on Missile Electronic Circuits", Hughes Aircraft Company, FR 63-17-32

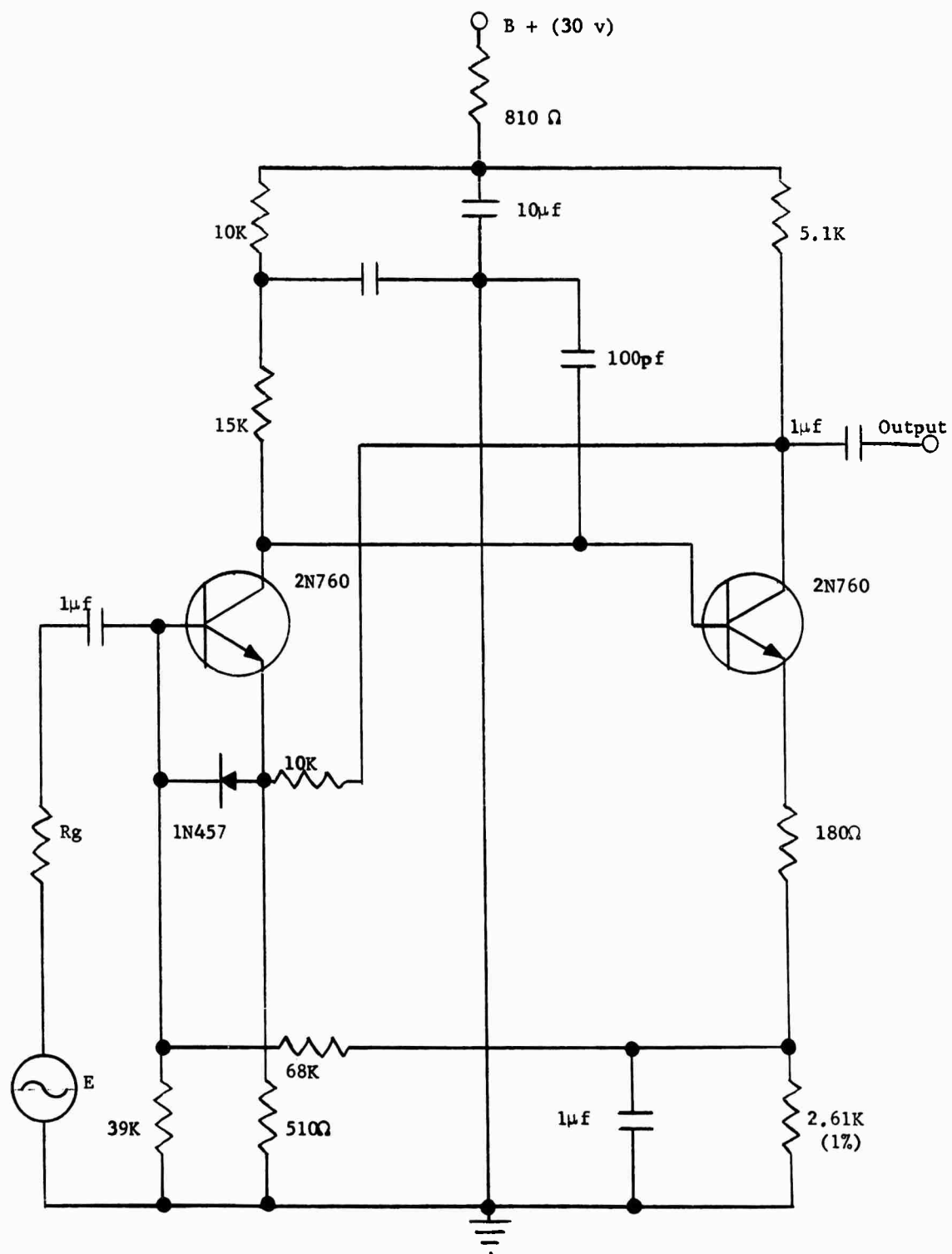

FIG. 1 KEARFOTT CLOSED LOOP TRANSISTOR AMPLIFIER

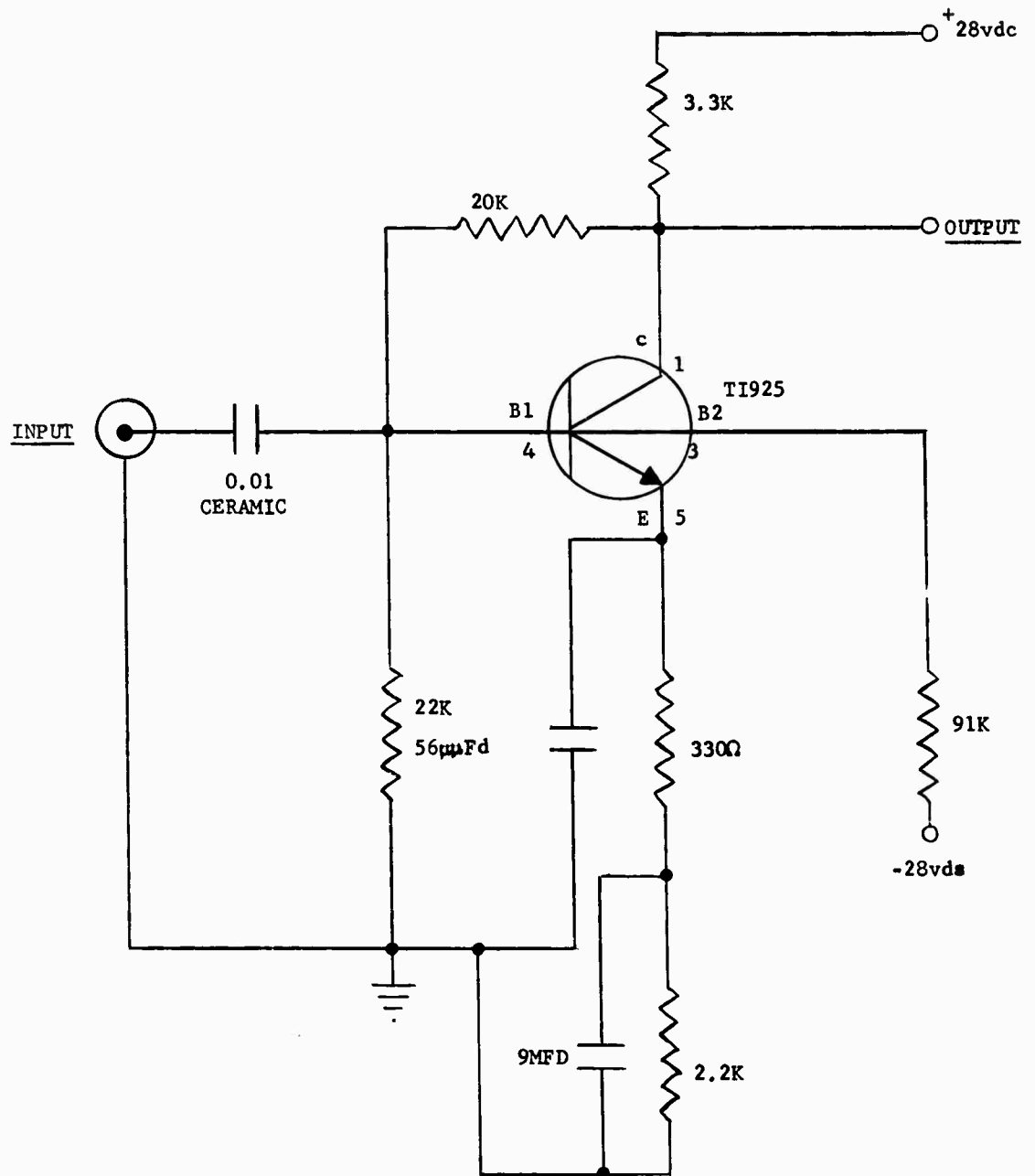

FIG. 2. TRANSISTOR AMPLIFIER

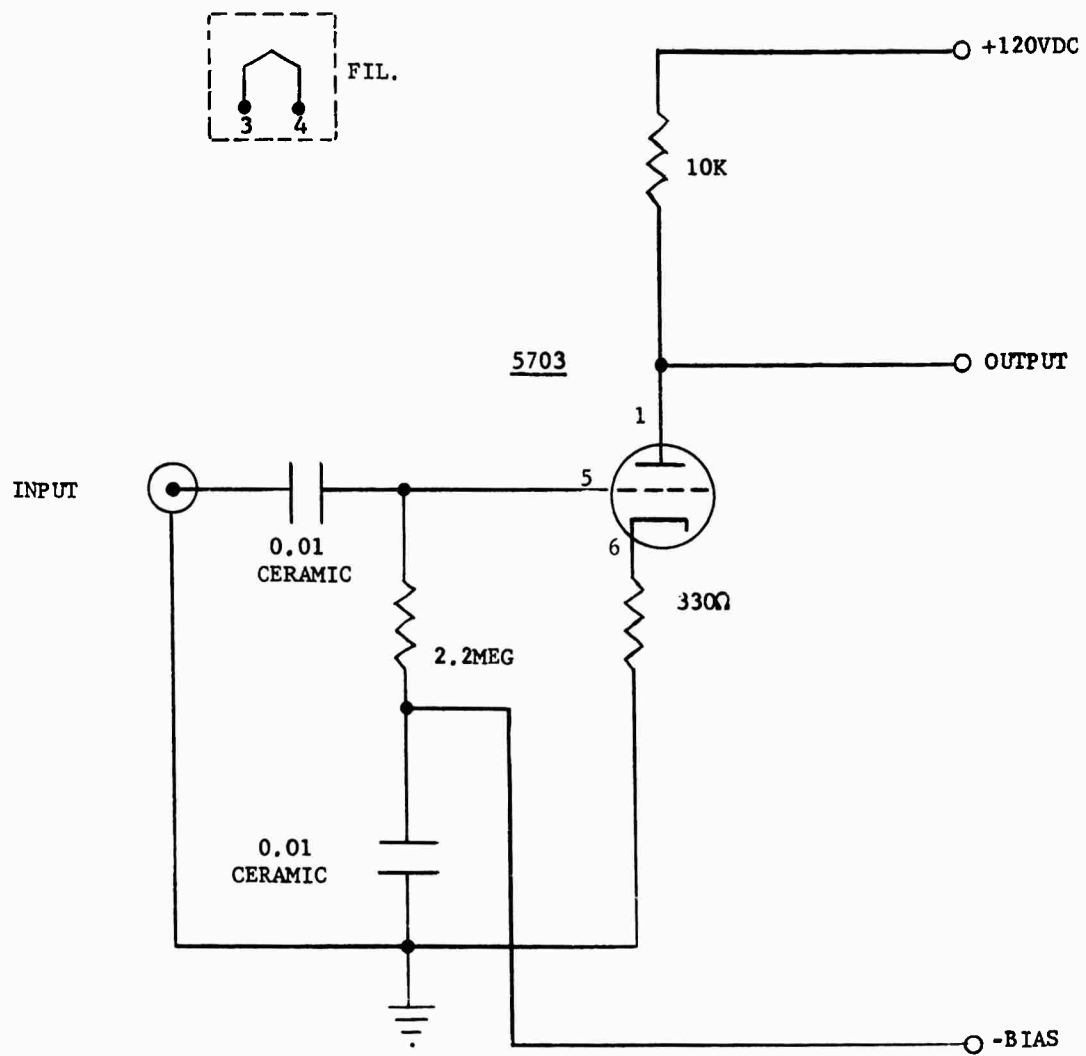

FIG. 3 TRIODE AMPLIFIER

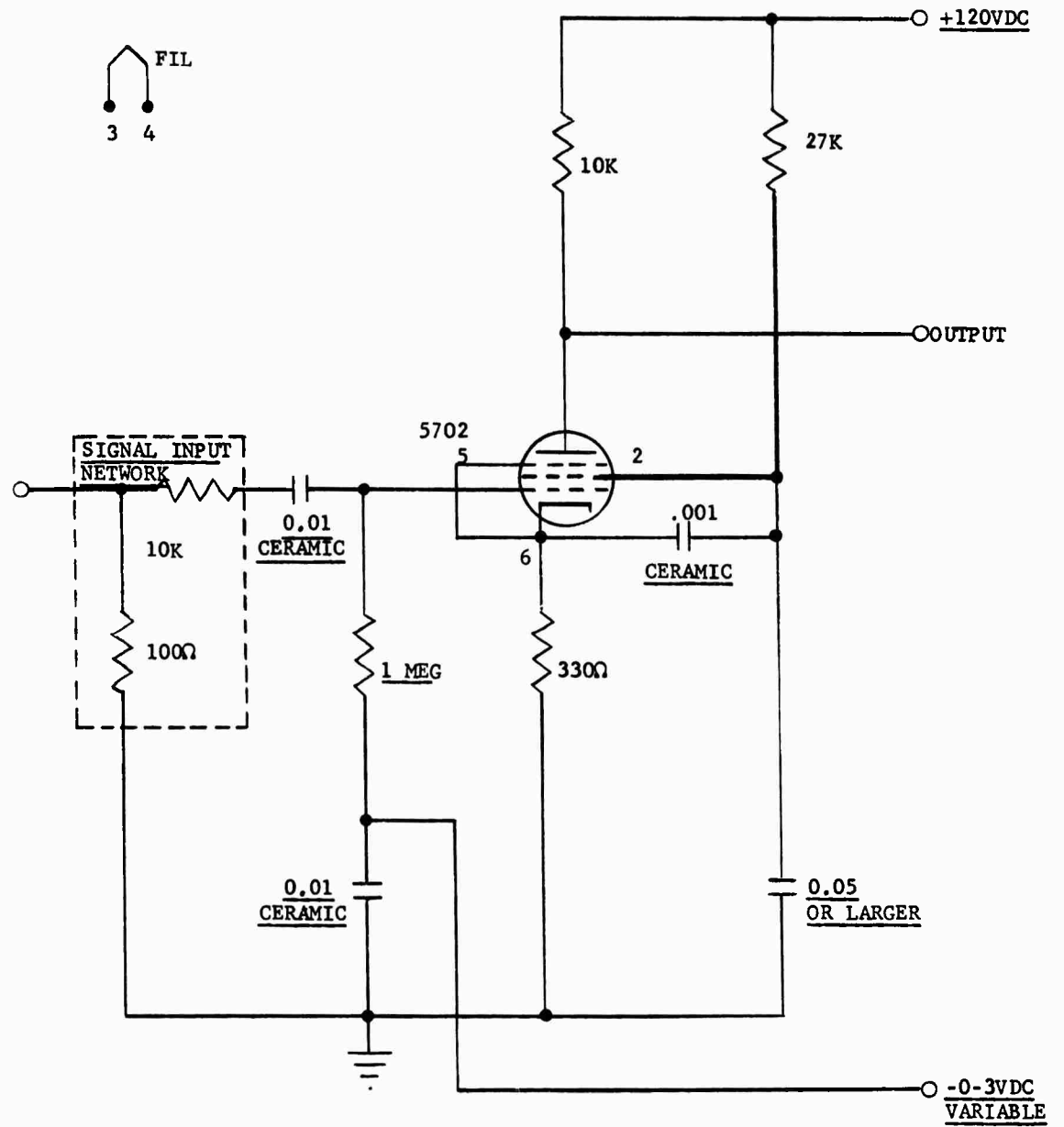
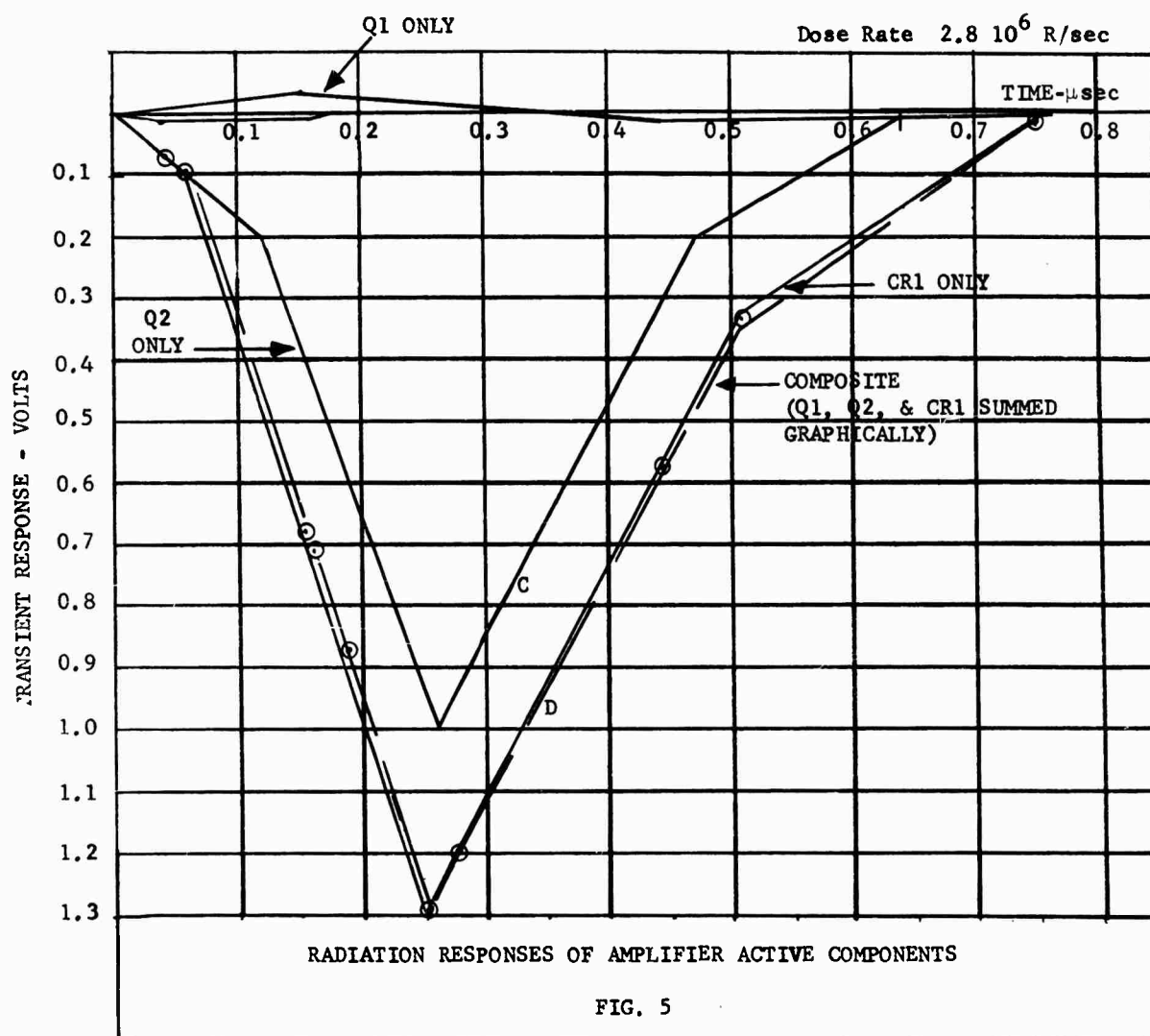

FIG. 4 PENTODE AMPLIFIER



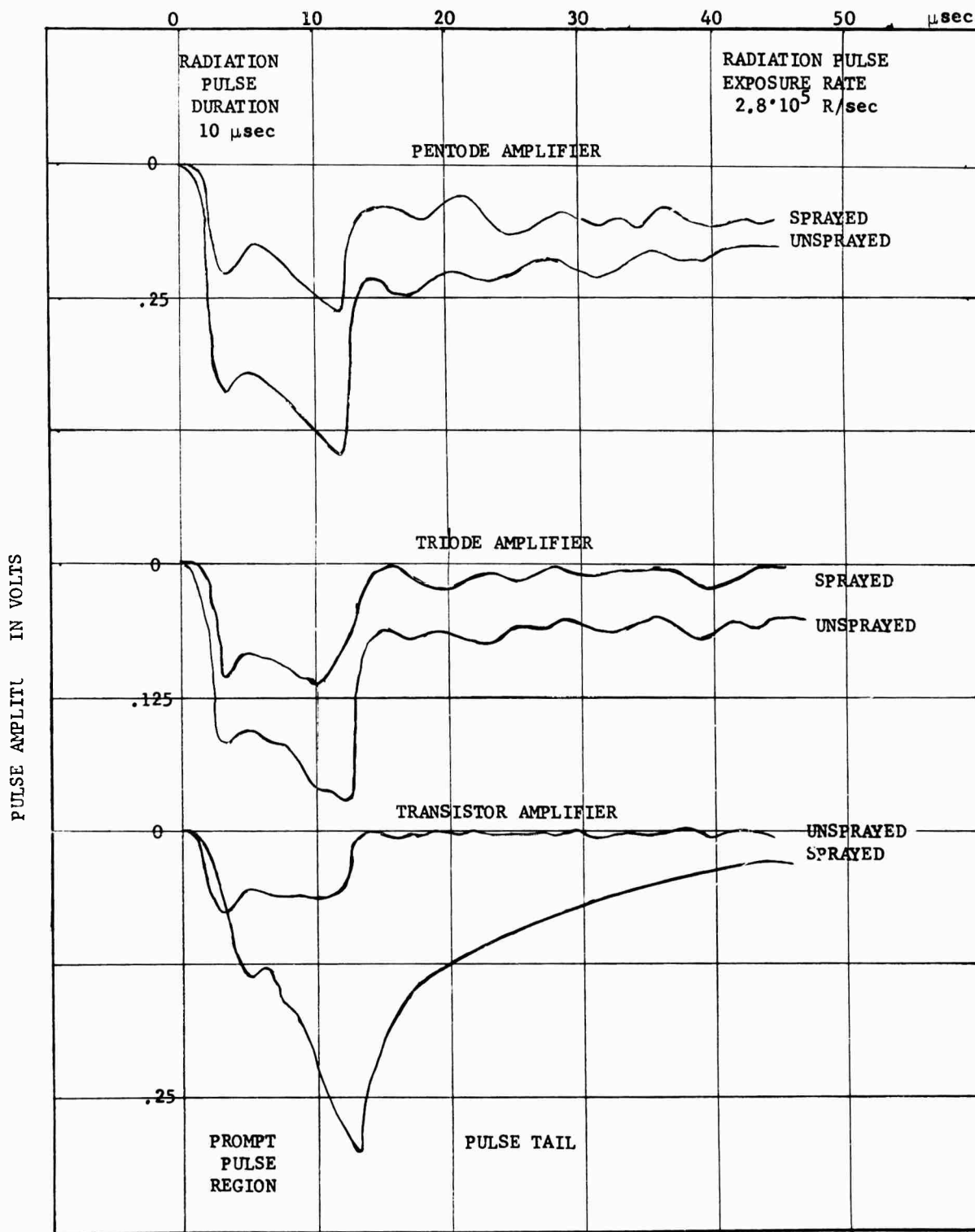

FIG. 6 RADIATION INDUCED AMPLIFIER PULSES

PART XI
A SURVEY OF GAMMA RADIATION
EFFECTS ON OSCILLATORS AND MULTIVIBRATORS

A SURVEY OF GAMMA RADIATION
EFFECTS ON OSCILLATORS AND MULTIVIBRATORS

Transient gamma radiation affects electronic circuitry by generating ionized regions in and about circuit components and circuit conductors. These ionized regions, over which small currents can pass, act to momentarily redistribute circuit charge. This redistribution of circuit charge may cause the circuitry to temporarily malfunction.

Transient radiation effects on oscillators have been investigated by subjecting whole oscillator circuits to radiation pulses, while monitoring the oscillator outputs for frequency and amplitude variations. (Ref. 1) Both vacuum-tube type and transistor type circuits were studied. The pulsed radiation environments were provided by an electron linear accelerator (Linac) at General Atomics and by the Godiva II critical assembly. The average gamma ray exposure rates and radiation pulse widths were 1.5×10^6 R/sec⁻¹ at 5 μ secs and 3.8×10^6 R/sec⁻¹ at 100 μ secs, respectively.

Figures 1 through 3 depict the schematic diagrams of the three voltage controlled oscillators (VCO) tested. The circuits consist of a multivibrator section followed by a filter to provide a sine wave output. Frequency control is achieved by the application of a d.c. voltage or a low frequency a.c. amplifier, which controls the bias level on the grids of the multivibrator tubes.

Possible sources of malfunction, due to a radiation burst on the VCO circuits, are the multivibrator sections; the d.c. amplifiers and the filtering units. Radiation can change the multivibrator frequency of operation by affecting the discharging rates of the frequency determining capacitors. Radiation effects on the d.c. amplifier can also affect the frequency of operation. Experimentation on diode amplifiers indicate that the d.c. amplifiers may exhibit a drop in plate voltage causing the multivibrator section to cycle at a slower rate. The filtering unit cannot cause the frequency to change, but could have some affect on the output amplitude and phase.

Figures 4 and 5 depict amplitude and frequency responses exhibited by the 70 kcs oscillator. At the Linac (See Figure 4) a maximum frequency

change of +3% with a recovery time of 100 μ sec was observed. This was accomplished by a decrease in amplitude of 10%, which recovered in 50 μ sec. At the Godiva tests the 70 kcs oscillator exhibited an initial small decrease in frequency, followed by a large increase of 20% at 50 μ sec, after the radiation interval. The frequency recovered its pre-radiation value in 1.5 sec. Accompanying this frequency change, the output amplitude decreased by 60%. The multivibrator sections was considered to be the dominant source of the effects observed.

The responses observed for the 40 kcs oscillator differed appreciably from those observed for the 70 kcs oscillator. In the Linac tests there was no discernible change in frequency of the 40 kcs VCO. The only effect observed was a reduction in amplitude of 5 to 10 percent for one or two cycles following the burst. At Godiva the 40 kcs VCO exhibited a 5% decrease in frequency (See Figure 6) and a 60% reduction in the output amplitude. This reduction in frequency has been attributed to the dominating response of the d.c. amplifier to the radiation pulse.

The greatest responses to the radiation was exhibited by the 22 kcs VCO. This is expected since transistors are known to be more sensitive to radiation than vacuum-tubes.

Figure 7 shows the response of the 22 kcs VCO in the Linac tests. The frequency decreased rapidly during the first few cycles and then reversed to an increase of about 5% before recovering at 300 μ sec. The variations in amplitude exhibited a fluctuating behavior changing by as much as 50% (See Figure 7). At Godiva the frequency increased 25% and recovered to 2% above its original value (See Figure 8). This was attributed to permanent damage caused by the neutron component; of the radiation pulse. The amplitude decreased by 90%.

In conclusion, transient responses of oscillators to a radiation pulse appear as fluctuations in frequency and amplitude. As expected, the vacuum-tube circuits displayed less sensitivity to the radiation than did the transistor circuit. In the transistor circuit the fluctuations apparently consisted of two effects: a fast, frequency-decreasing effect, and a slow, frequency-increasing effect. The irradiation of the transistor circuit with

a 100 μ sec pulse at Godiva revealed that the latter effects was dominant for long pulse widths. In general, the fluctuations attained some final peak value and recovered in a time long compared with the radiation pulse duration.

REFERENCES

1. Perkins, C. W., "Effect of Radiation on Ordnance Missile Components, Task 1, Infrared Materials, Voltage Controlled Oscillators", Diamond Ordnance Fuze Laboratories, Contract No. DA-04-495-502-ORD-1819, December 1960.

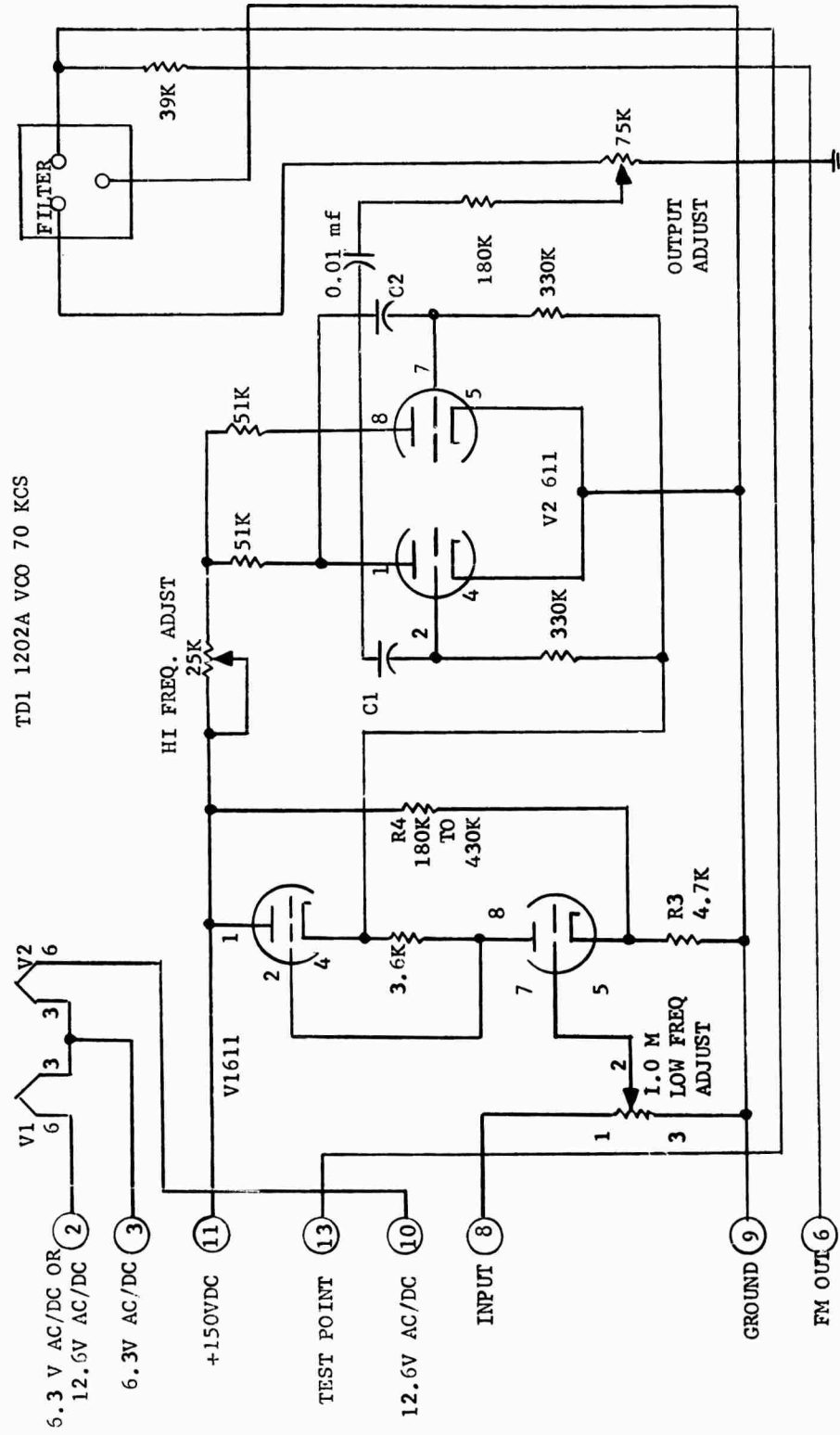
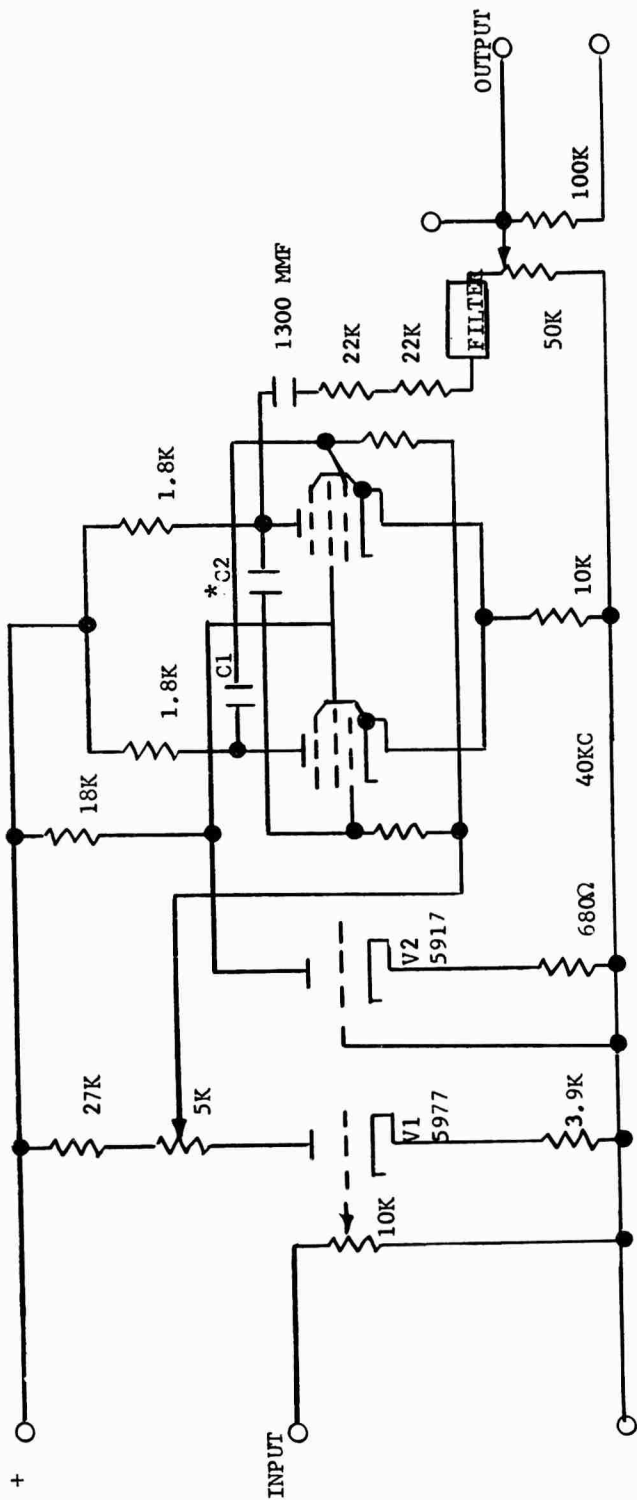

FIG. 1 CIRCUIT FOR 70 Kcs VCO

VCO, EMR 75B 40 KC



* C1, C2

1000 MMF 40KC

FIG. 2 CIRCUIT FOR 40 Kcs VCO

TD11250 A VCO 22 KCS

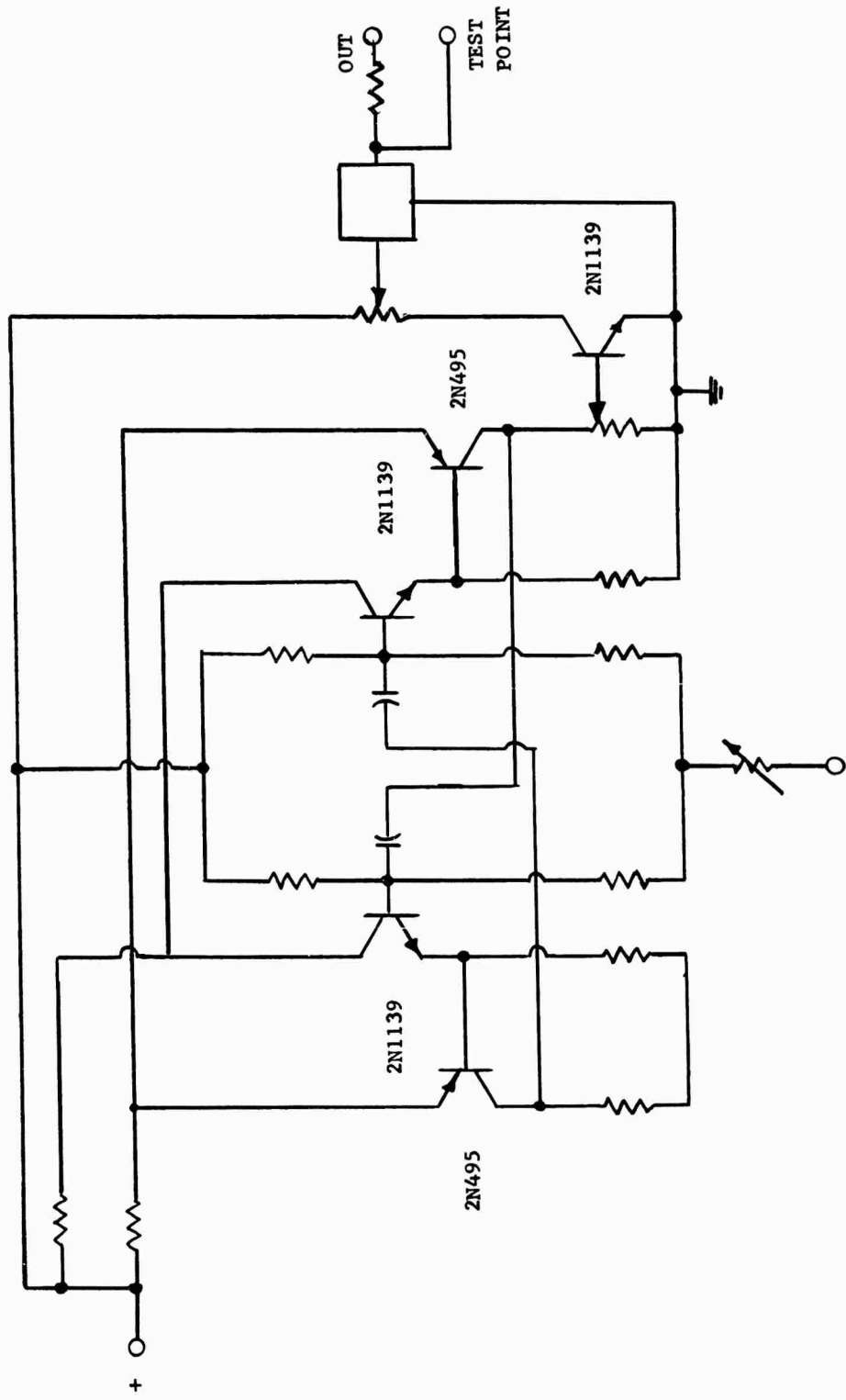

FIG. 3 CIRCUIT FOR 22 Kcs VCO

GENERAL ATOMIC LINAC, SEPT 1960

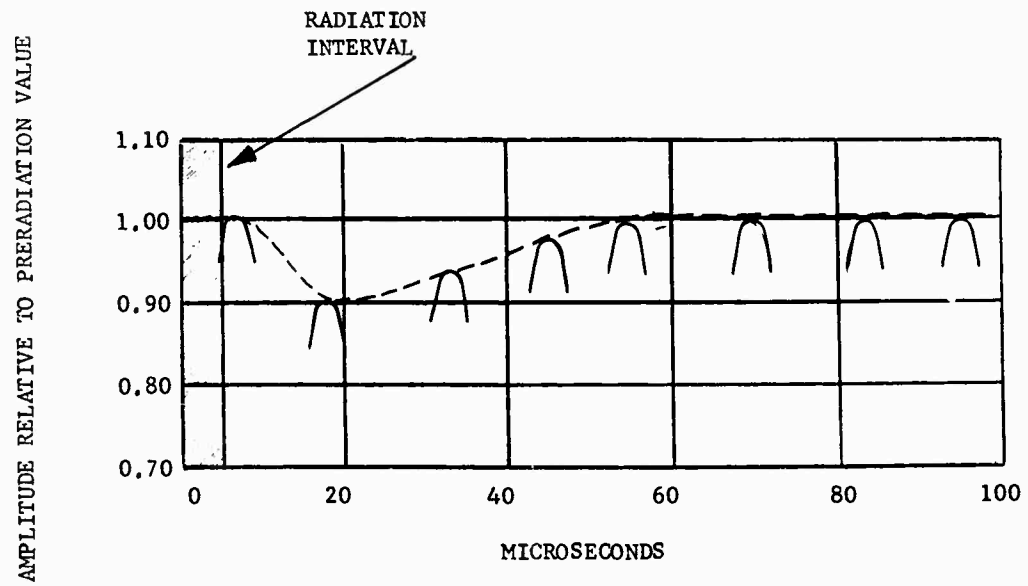
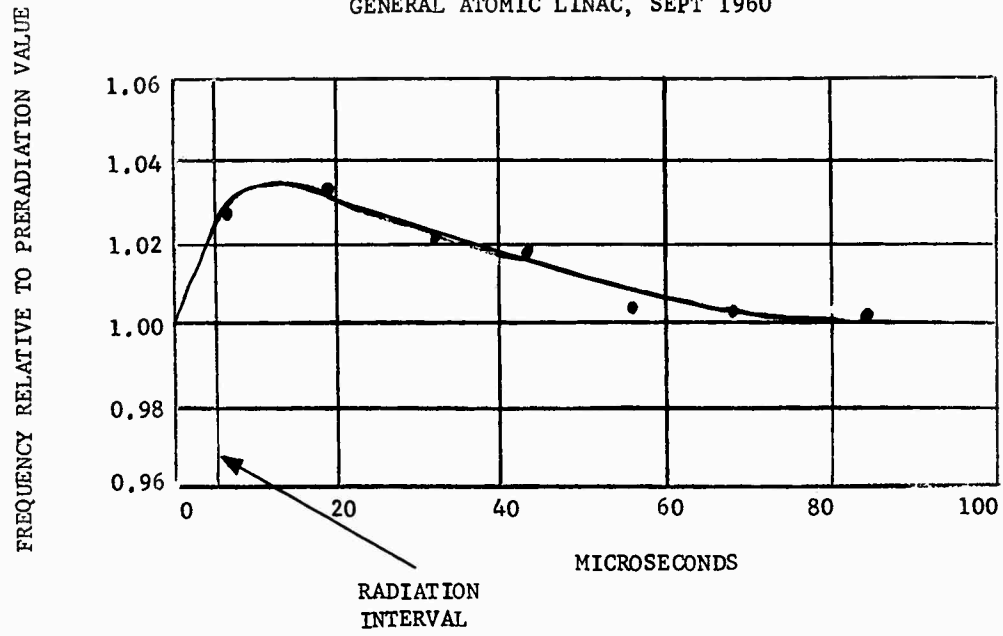

FIG.4 RESPONSE OF 70 Kcs VCO IN LINAC TESTS

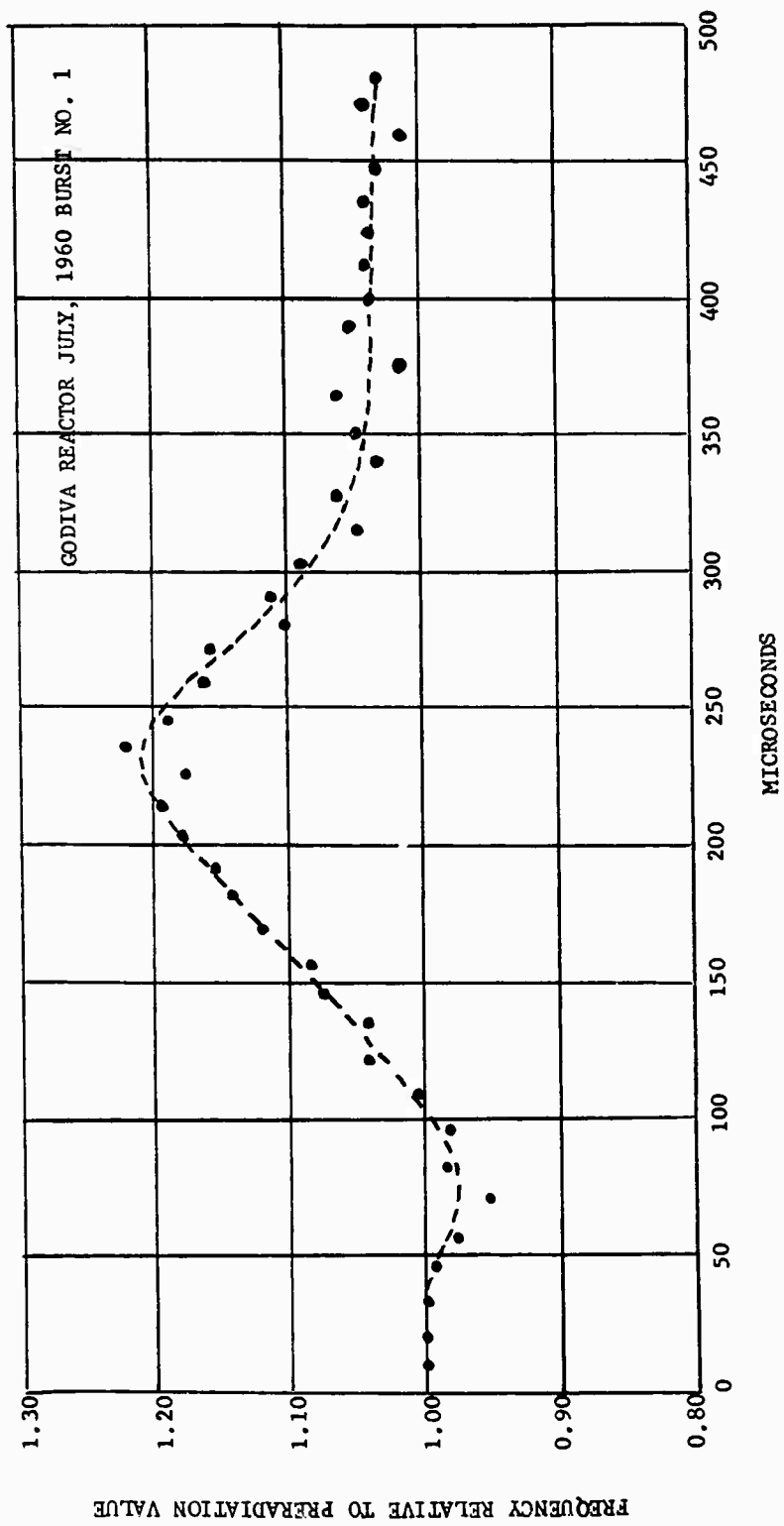
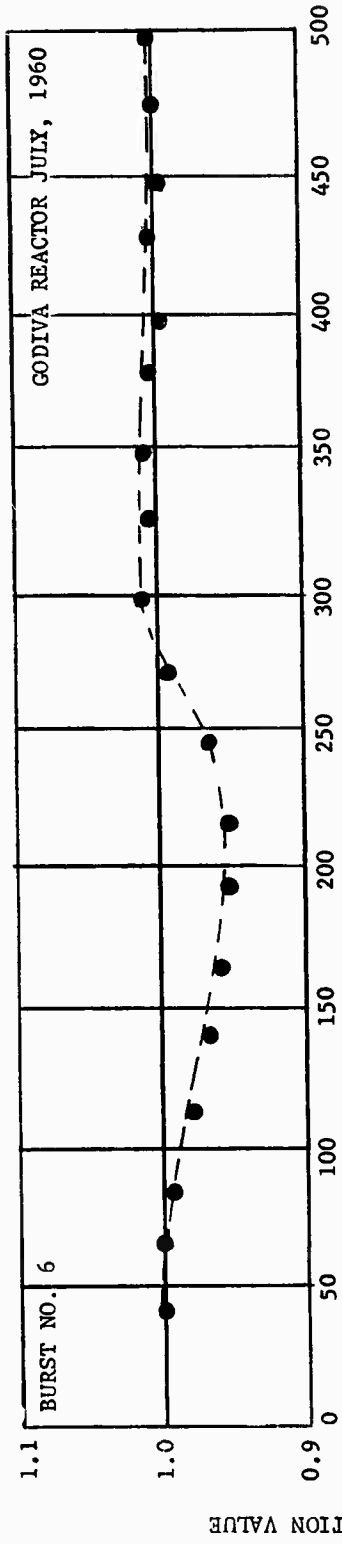
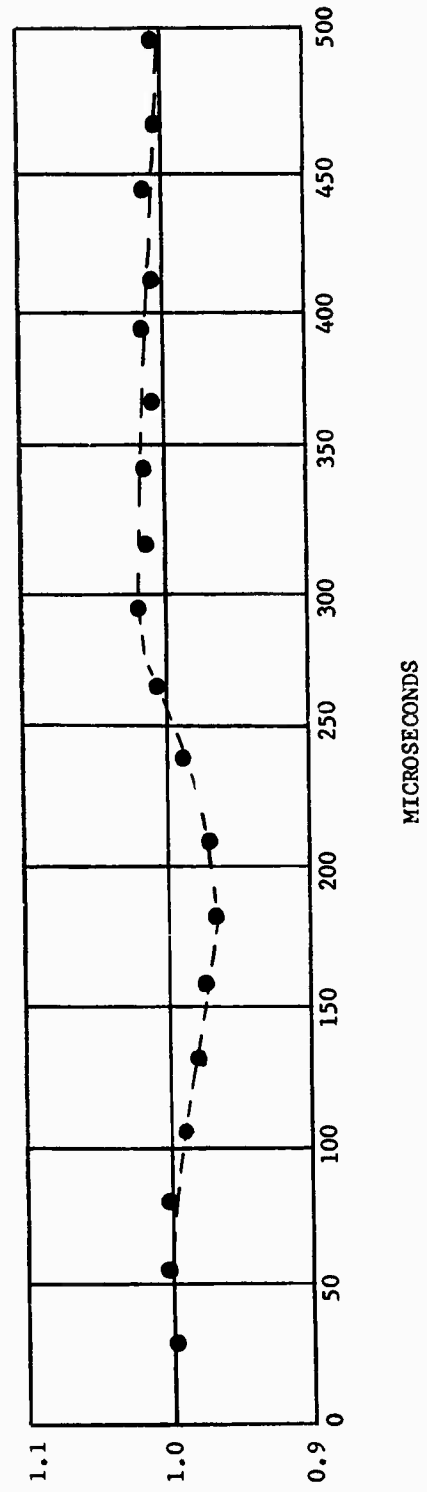

FIG. 5 RESPONSE OF 70 Kcs VCO AT GODIVA



MICROSECONDS

FREQUENCY RELATIVE TO PRERADIATION VALUE



MICROSECONDS

FIG. 6 RESPONSE OF 40 Kcs VCO AT GODIVA

FIG. 7 RESPONSES OF 22 Kcs VCO IN LINAC TESTS

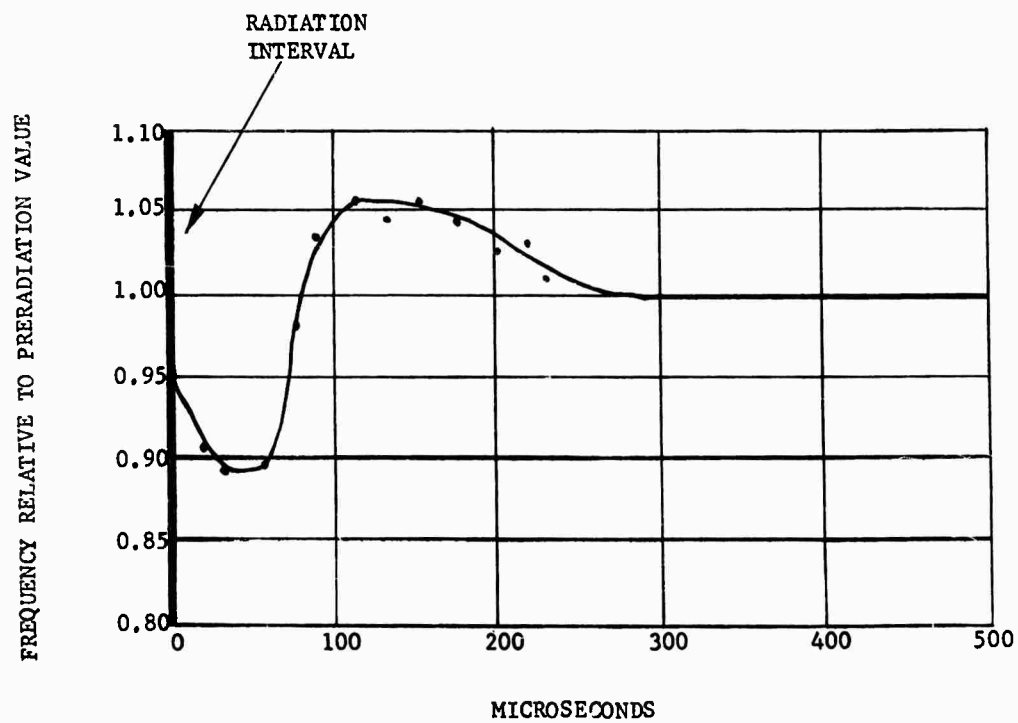
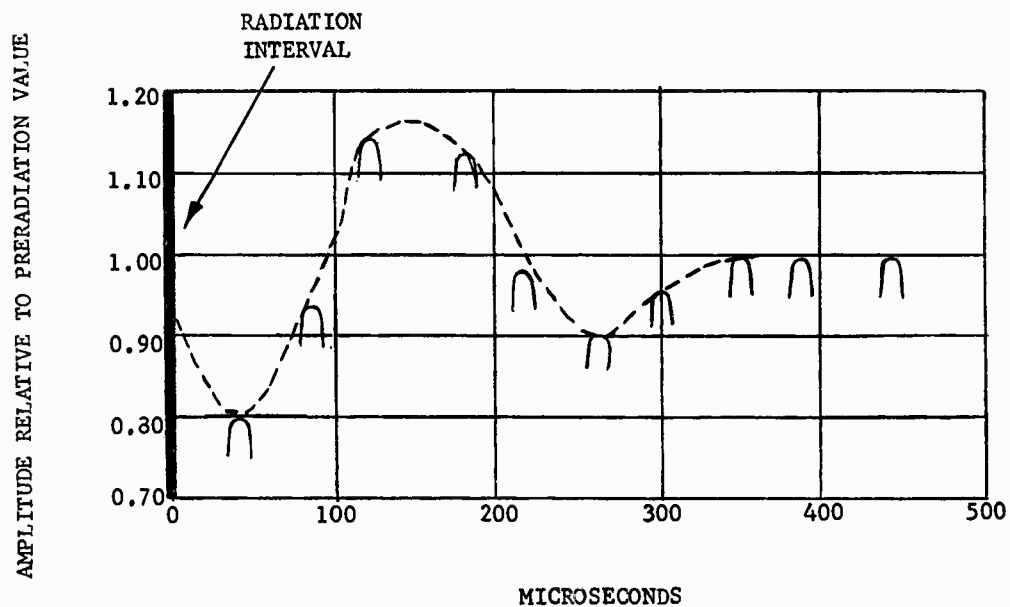

PART XII
MATHEMATICAL TECHNIQUES FOR ANALYZING IRRADIATED CIRCUITS

MATHEMATICAL TECHNIQUES FOR ANALYZING IRRADIATED CIRCUITS

INTRODUCTION

Nuclear radiation affects electronic circuits by changing the circuit's charge distribution. The radiation effects may be due to ionization leakage, pair production, Compton scattering, photoelectric effects, or lattice displacements. These mechanisms can be lumped into the following groups - ionization leakage, charge scattering, and charge integration (storage) - for use in analyzing irradiated circuits. It is also possible that component parameter values (resistance, capacitance, transistor current gain, etc.) may change as a result of radiation. Mathematical or graphical descriptions of all radiation effects (ionization leakage, charge scattering and storage, and component parameter value changes) are employed in determining radiation induced circuit responses.

DESCRIPTION OF TECHNIQUE

Circuit analysis techniques are based on component models that represent normal circuit operation. Individual component models are modified where required to include radiation effects. These modifications are usually of the following form:

1. Ionization leakage is represented by the addition of "leakage resistances", where significant, between the leads of physical components and between adjacent circuit conductors (wires and printed circuitry). Leakage resistances are also added to simulate the ionization effects in insulating package materials and in the component surroundings (printed circuit boards, potting compounds, air, etc.).
2. Charge scattering is represented by "injected current" generators which extract electrons from all physical components. Charge storage is represented by "charge integrators" (capacitors) to account for the semi-permanent charge storage exhibited by various irradiated semiconductors following termination of the radiation pulse.

3. Component parameter value changes are represented according to the nature of the effect, i.e., injected current into the base terminal of the transistors to account for the change in carrier density due to radiation.

The radiation effects component models (leakage resistances, injected currents, and charge integrators) are referred to as radiation parameters. These parameters are defined by experimental irradiation of physical components at various radiation dose rates or total dose levels.

The circuit analysis procedure follows these steps:

1. Define the radiation environment. The time history of the radiation fluxes in peak amplitude and duration will define the environment and will in turn establish the time-history shape of the radiation parameters.
2. Develop an equivalent circuit (mathematical model) which describes the normal operation of the circuit. This equivalent circuit is entitled, "equivalent circuit in the absence of radiation".
3. The equivalent circuit in the absence of radiation is modified to include radiation effects on individual components. (inclusion of radiation parameters). This modification yields the "equivalent circuit in the presence of radiation".
4. Develop mathematical equations which describe the circuit's operation before, during, and following the radiation interval. An analog computer is usually employed to solve these equations.

APPLICATION OF TECHNIQUE

An example which demonstrates steps 2 and 3 will now be given. The circuit to be studied is shown in Figure 1.

The transistor operates as a linear device and can be represented by a linear model. Figure 2, the equivalent circuit in the absence of radiation, represents normal circuit operation.

The active device is represented as an "h" parameter model. Any other model which describes its linear operation could be utilized. Radiation parameters are now included to depict the effects due to the radiation environment. Figure 3, the equivalent circuit in the presence of radiation, is thus formed. This equivalent circuit was developed by including leakage resistances and injected currents throughout the model (charge integrators are not included in the model). Some of the radiation parameters will not appreciably effect circuit performance; they are included, however, to show general applicability.

Mathematical equations for the circuit in Figure 3 are developed from this equivalent circuit to describe the circuit operation before, during, and following the radiation interval.

The resulting equations in Laplace notation are:

1. Input node

$$\left[e_1 - e_s \right] \frac{1}{R_g} + (e_i - e_1) \left(C_1 s + \frac{1}{R_{L2}} \right) + \frac{e_i}{R_{L1}} - i_{rc1} = 0$$

2. Node No. 1

$$\begin{aligned} & (e_1 - e_2) \left(C_1 s + \frac{1}{R_{L2}} \right) + (e_1 - \frac{v}{s}) \left(\frac{1}{R_1} + \frac{1}{R_{L3}} \right) + \left[e_1 - h_r (e_2 - e_3) - e_3 \right] \frac{1}{h_i} \\ & + (e_1 - e_2) \frac{1}{R_{L4}} + \frac{e_1}{R_{L11}} - i_{rc1} - i_{rb} - \frac{i_{r1}}{2} = 0 \end{aligned}$$

3. Node No. 2

$$\begin{aligned} & (e_2 - e_1) \frac{1}{R_{L4}} + (e_2 - \frac{v}{s}) \left(\frac{1}{R_2} + \frac{1}{R_{L6}} \right) + (e_2 - e_o) \left(C_2 s + \frac{1}{R_{L9}} \right) + (e_2 - e_3) \\ & \left(\frac{1}{R_{L7}} + h_o \right) + \frac{e_2}{R_{L8}} + \frac{h_f}{h_i} \left[e_1 - h_r (e_2 - e_3) - e_3 \right] - i_{rc2} - \frac{i_{r2}}{2} = 0 \end{aligned}$$

4. Node No. 3

$$\left[e_3 + h_r (e_2 - e_3) - e_1 \right] \frac{1}{h_i} + e_3 \left(\frac{1}{R_3} + \frac{1}{R_{L5}} \right) + (e_3 - e_2) \left(\frac{1}{R_{L7}} + h_o \right) - \frac{h_f}{h_i} \left[e_1 - h_r (e_2 - e_3) - e_3 \right] - \frac{i_{r3}}{2} = 0$$

5. Output Node

$$(e_o - e_2) \left(\frac{1}{R_{L9}} + C_2 s \right) + e_o \left(\frac{1}{R_{L10}} + \frac{1}{R} \right) - i_{rc2} = 0$$

6. Initial conditions (i.e., voltages across capacitors) are known constants.

The analog computer program which solves the circuit equations is designed so that the radiation parameters can be included or withdrawn from the program to depict the radiation interval. The time-history of the radiation parameters is generally rectangular in shape. Rectangular parameters can be used when circuit RC time constants are considerably longer than the radiation interval. When this condition exists, the period following the radiation pulse is of major importance as it shows the circuit's long recovery time. If the circuit RC time constants are approximately equal to the radiation duration, the time-history of the radiation parameters may necessarily be established by the radiation time-history. However, it is possible in many cases to use results obtained from the various rectangular parameters and synthesize an overall response to an irregularly shaped radiation environment.

The above analysis techniques were developed for transient radiation effects studies. Studies are now in progress toward applying these techniques to steady-state radiation problems. In steady-state radiation environments (or in transient environments where permanent or semi-permanent effects exist), the parameter values of individual circuit components may be degraded. If this degradation can be described mathematically or graphically, it can be included in the previously developed analytical techniques to determine the circuit's operation when permanent effects occur.

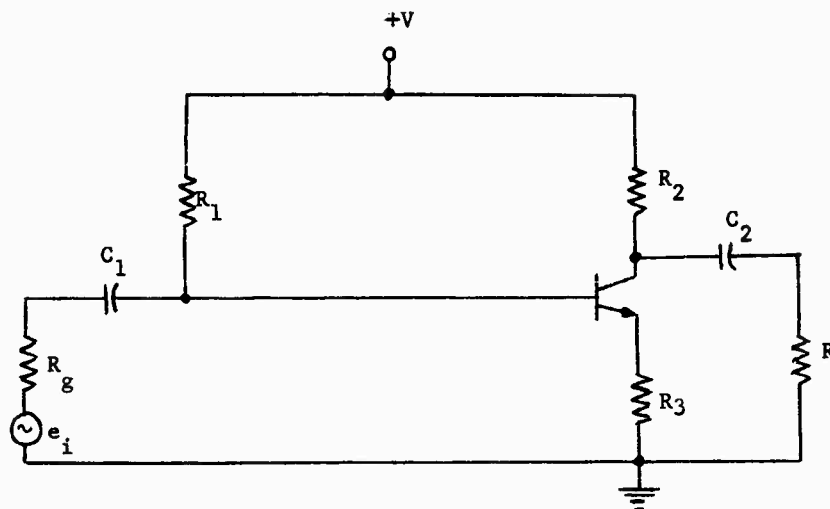

FIGURE 1

Schematic of transistor amplifier to be analyzed during irradiation. Signal source and load R are not to be irradiated.

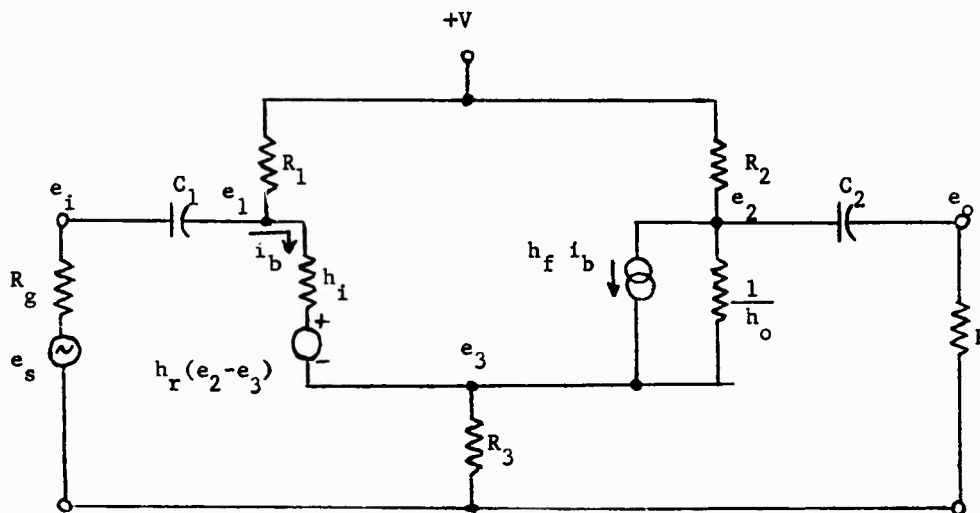

FIGURE 2

Equivalent Circuit in Absence of Radiation

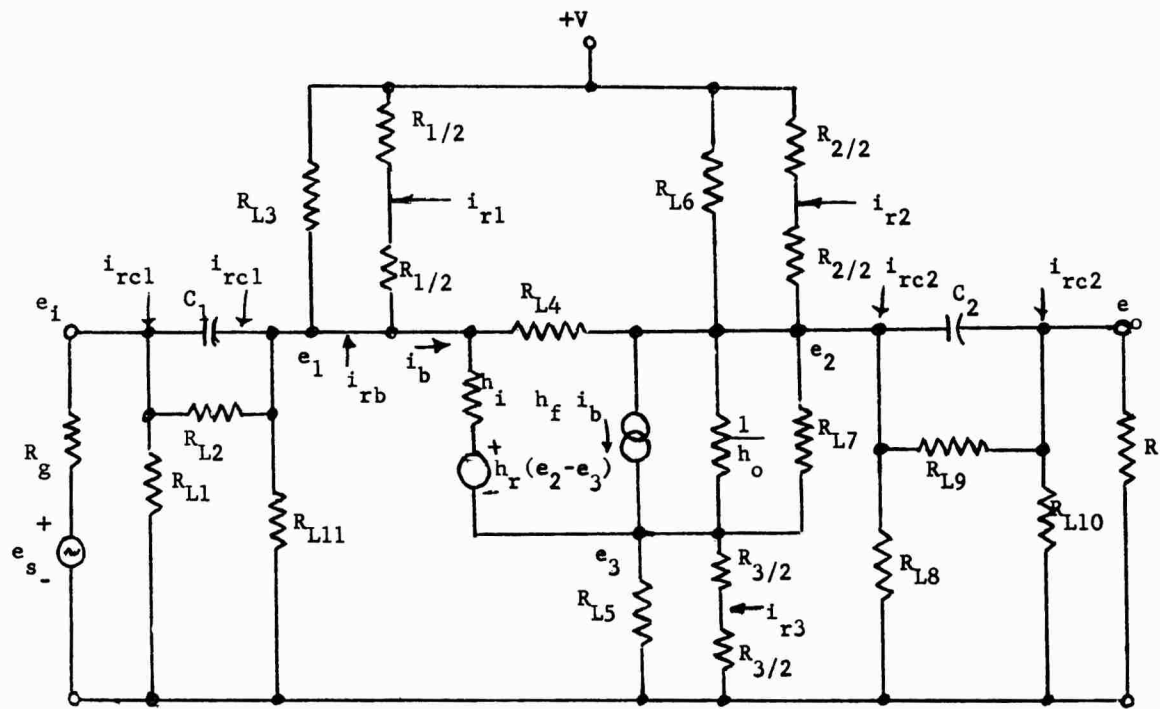

FIGURE 3: EQUIVALENT CIRCUIT IN PRESENCE OF RADIATION

PART XIII
ELECTRONIC SYSTEMS IN NUCLEAR
RADIATION ENVIRONMENTS

ELECTRONIC SYSTEMS IN NUCLEAR RADIATION ENVIRONMENTS

INTRODUCTION

Electronic system designers must insure that their systems will function properly in all environments which may be encountered. In the past, environmental considerations of temperature, humidity, pressure, shock, and vibration were usually sufficient to insure system operation and reliability. In recent years an additional environment, which can seriously affect the performance of electronic systems, has increased in importance. This new environment is the nuclear radiation associated with nuclear weapons, nuclear reactors, and outer space.

System designers and analysts treat all environments as "threats" that may cause permanent or temporary malfunctions in electronic systems. The radiation environment is one of these "threats". In comparison to all other "threats", the radiation environment presents problems that most circuit and system designers have not experienced.

Unlike other "threats", the radiation environment may be extremely difficult to simulate. Mechanical apparatus such as shock and vibration machines, high and low temperature ovens, humidity rooms, pressure chambers, wind tunnels, etc., have helped designers insure system operation and reliability. A simulation problem arises, if one is concerned with the radiation fluxes associated with a nuclear weapon environment. Laboratory machines which can exactly duplicate these fluxes do not exist; hence, all implications, resulting from contact with an environment of this type, are difficult to define. However, with careful experimentation and analysis, data can be generated from weapon simulators and correlated with the weapon environment. The transient behavior of the weapon radiation fluxes proposes additional simulation difficulties. Notwithstanding the instrumentation required to monitor effects due to this, transient phenomena can impose problems to even the more experienced experimenters.

Perhaps the gravest problem arises from the "newness" of the radiation "threat". Most designers have not encountered radiation specifications in their programs as yet. The inclusion of nuclear weapons as tactical military devices is beginning to demand that the designers include radiation considerations in their designs. Likewise, the continuing space programs recognize the severity of space radiations, and future programs will undoubtedly require expanded nuclear radiation considerations so that reliable system operation can be maintained.

GENERAL CONSIDERATIONS

Nuclear radiation effects on electronic systems can be grouped into permanent effects and transient effects, or a combination of the two. Permanent effects arise from changes in the electrical characteristics of individual circuit components. The effects, which result from molecular changes within the component materials, persist after the component has been removed from the radiation environment and are usually irreversible. In some instances, after long annealing times, the component characteristics may recover to their pre-radiation levels and the system operation will be normal. Transient effects on electronic systems are due to the high radiation fluxes causing a redistribution of charge within the circuits that make up the system. The charge redistribution may be due to ionization leakage, charge scattering resulting from photoelectric and Compton scattering phenomena (photoconductivity), and transient changes in component parameter values. In general, the redistribution of charge recovers to normal in a period that is much longer than the radiation duration. This recovery time is dictated by system RC time constants; hence, any perturbations induced by radiation are within the systems bandwidth.

Transient radiation effects on electronic systems can be caused by the radiations associated with weapon environments. Permanent effects may also be experienced in irradiations in a weapon environment; or they may be observed from irradiations in the near vicinity of a nuclear reactor. Likewise, the radiation environments in outer space can cause permanent effects.

DETERMINING IRRADIATED SYSTEM RESPONSES

The radiation responses of electronic circuits or systems can be determined through experimental or theoretical study programs. The most informative experimental method for determining radiation effects entails actual tests in the environment of interest, (generally the weapon environment). Engineering and economic problems combine to make tests in the weapon environment impractical. Therefore, experimental programs have been established using laboratory radiation simulation sources, (e.g., pulsed reactors, LINAC's, flash X-ray machines, etc.), to measure the responses of irradiated circuits and systems (ref. 1). The results obtained from various laboratory tests can then be combined and correlated in attempts to determine the types of responses that might be observed in a weapon environment.

The theoretical programs established to date have been necessarily limited to studying the responses of small circuits. The known responses of irradiated components have been employed in analyzing circuit responses to pulsed gamma radiation. The theoretical techniques (Ref. 2 and 3) developed by Hughes have been shown to be fairly accurate by subsequent experimental observations of circuit responses. Studies are now in progress to extend these techniques and to develop additional techniques for theoretically predicting the responses of electronic systems to nuclear radiation.

Experimental field tests in which complete missile systems were irradiated at a pulse reactor (Ref. 1 and 4), have been conducted by Hughes. During irradiation, the missile systems were in operational modes which were established by system checkout simulators; all operational modes except the aerodynamic loop were employed. The types of radiation responses that were observed are as follows: (1) loss of target with subsequent reacquisition, (2) wing and stabilizer deflections, (3) complete subsystem failures (e.g. power supply failures due to neutron dose effects), (4) irreversible processes in digital circuits (used in computers, fuzes, and target detecting devices) which can cause effective permanent effects.

After missile irradiations at a pulsed reactor facility, the radiation sensitive subsystems can be tested at a linear accelerator (LINAC) and the sensitive area identified. Tests of this type have been performed at the Hughes Research LINAC. (Ref. 1).

CONCLUSIONS

Experimental irradiations of electronic circuits and systems have demonstrated that nuclear radiation can cause either permanent and/or transient malfunctions in electronic equipment. The seriousness of the transient malfunctions cannot be adequately judged without considering system or circuit performance in specific tactical and operational situations. However, they do indicate that circuit and system designers must consider the nuclear radiation environment as another "threat" that can abort their system.

The responses of an irradiated circuit or system can be determined experimentally or theoretically. Experimental programs in which complete missiles were irradiated have been conducted by Hughes at various reactor facilities. These programs were very successful in determining the sensitivity of individual systems (or subsystems within the overall system) to nuclear radiation. Additional experiments performed at the Hughes Research LINAC aided in determining sensitive circuit areas or components. In this case the LINAC is used as a "probing" device. By combining and correlating the results obtained from reactor and LINAC experiments, it is possible to reasonably duplicate the responses which would be caused by a nuclear weapon environment.

The theoretical approach developed at Hughes has proven to be effective in predicting the radiation responses of small electronic circuits. As new analytical techniques are developed and actual system responses are predicted, circuit and system designers will have powerful tools to employ in the radiation hardening of their equipment.

REFERENCES

1. J. E. Bell, R. D. Loveland, and F. W. Karpowich, Final Report, "Transient Radiation Effects Experiments on the Talos 6c1 missile (U)", Hughes Aircraft Company, FR 62-17-74, September 1962, Contract NOrd 19161 (S-RD).
2. J. E. Bell and K. R. Walker, "Theoretical Study of Burst Induced Transient Radiation Effects in Basic Electronic Circuits", Final Report on Contract AF 29(601)-2538 AFSWC TDR-61-40, May 1961 (U).
3. J. E. Bell, et al, "Theoretical Study of Burst-Induced Transient Radiation Effects in Basic Electron Circuits", Final Report on Contract AF 29(601)-4743, AFSWC TDR-62-118 (U), and TDR-62-118 Supplement, (S-RD) September 1962.
4. J. E. Bell, R. D. Loveland and D. A. Steele; Final Report, "Transient Radiation Effects Experiments on the Guided Missile Complete Round (Terrier BT-3) Mark I Mod. 0", Hughes Aircraft Company FR 62-17-43, July 1962, Contract Nord 19161 (C).

PART XIV
TRANSIENT RADIATION EFFECTS ON
MAGNETIC DEVICES

TRANSIENT RADIATION EFFECTS ON MAGNETIC DEVICES

Since the performance of magnetic devices depends primarily on the properties of the magnetic case, the effect of a nuclear environment on the case and on case materials is of interest. For optimum performance, the core should have the following properties:

1. minimum hysteresis and eddy-current losses
2. high value of saturation flux density
3. rectangular magnetization curve
4. stability to environments of temperature, mechanical strain, and shock.

Historically, permanent radiation effects were studied first in many experiments. The conclusions drawn from these tests were that silicon and aluminum-iron alloy cores were very resistant to radiation. The studies also indicated that high nickel-iron alloys exhibited excessive changes in permeability, remanence, and loop rectangularity under a nuclear environment.

None of the early tests included dose rate data, so that the effects of transient radiation were not known. In order to predict response to a radiation pulse, the designer is interested in instantaneous changes in the critical points of the hysteresis loop. The main interest is in the threshold point, the remanent flux density (B_R), saturation flux density (B_S), and the B_R/B_S ratio. In addition to these physical characteristics, further data is required on the changes in the core, while being driven in various applications. For example, it would be good to know if certain dose rates are able to drive the core from one state to another under varying conditions of drive. Recent experiments at Sandia Pulsed Reactor (SPR) (1,2,3,4,5) and Godiva II Pulsed Reactor, were performed by I.B.M., using the following tests:

1. Pulse Tests
2. Write Disturb Zero Tests
3. Disturb Tests
4. "One" - "Zero" Tests
5. Static Tests

In each of these test, voltages across "read" and "write" windings were monitored under varying drive current situations corresponding to actual working conditions. The nuclear environments were of the order of 5×10^9 , 5×10^7 rads/sec, gamma exposure rate (total gamma dose of 5×10^3 rads) and 2×10^{12} n/cm² integrated neutron dose at SPR, and at Godiya II were of the order of 2×10^7 rads/sec (total gamma dose of 2.5×10^3 rads and 1.8×10^{12} n/cm² integrated neutron dose.

The measurable permanent damage to any of the memory cores exposed to the pulsed radiation was observed. In general, the magnetic devices did not exhibit any major degradation due to the pulsed radiation. No transient radiation effects were observed in the memory cores during any of the tests conducted except in the "pulse" and "disturb" investigations. A number of unexplainable inconsistencies were noted in the test data so that additional testing is necessary to ascertain if real transient effects were observed in the "pulse" and "disturb" tests. However, magnetic devices are much more radiation resistant than other electronic components, such as transistors, semiconductor diodes, silicon controlled rectifiers and capacitors, thus, most circuits that contain magnetic devices will be disturbed by other component's malfunctions, first.

REFERENCES

1. "Transient Radiation Effects on Electronic Components and Semiconductor Devices", REIC Report No. 26, April 19, 1963, Battelle Memorial Institute.
2. "Some Effects of Pulsed Radiation on Electronic Components - II", Report No. 58-816-549, IBM.
3. "Study of Effects of High-Intensity Pulsed Nuclear Radiation On Electronic Parts and Materials" (SCORRE), Report No. 1, Progress Report 1 July 1960 - 30 September 1960.
4. "Study of Effects of High-Intensity Pulsed Nuclear Radiation on Electronic Parts and Materials", (SCORRE) Report No. 4, Progress Report 1 April 1961 - 31 June 1961.
5. "Study of Effect of High-Intensity Pulsed Nuclear Radiation on Electronic Parts and Materials (SCORRE) Report No. 8, Progress Report 1 April 1962 - 30 June 1962.

PART XV
METHODS TO HARDEN A SYSTEM

I. DESIGN PHILOSOPHY

Generally, one cannot expect the circuit to operate through the gamma ray spike, but with proper design it should be possible to have it recover in a sufficiently short time that the mission will not be adversely affected. The most vulnerable units are those which operate at high impedances, high gain levels, or which store charge. In most cases the circuits will recover with their inherent electrical time constants. The most catastrophic effects are those which are irreversible, uncontrollable over the times of interest; such as a change of state of a memory element or the irreplaceable charge removal from a storage element.

The more complex a system's functions, the more difficult to harden the system from radiation. The time scale of the system is important; for example if the system can be completely dead for 1 millisecond without affecting performance; then the system could be easily hardened. It should be remembered that the following design philosophy should be used in designing radiation hardened systems:

1. An interruption should not produce a destructive transient in the system response.
2. A minimum of information should be stored from before the pulse to after, and this information should be stored in a hardened system which will survive the radiation pulse, such as a magnetic core.
3. The system must recover in the required time. The capacitors must charge up quickly.

II. COMPONENT AND CIRCUIT SELECTION PHILOSOPHY

- (1) Select the best possible components for radiation resistance.
- (2) Choose the circuits which can make use of those better component (for example, use megamps instead of flip-flops at critical locations).
- (3) Design circuit so that leakage tends to turn voltage off instead of on.

- (4) If possible, put in a special system which senses the radiation pulse and deliberately disables the system temporarily.
- (5) a. Use semiconductor devices with small junction areas, base widths and diffusion lengths. Use very high frequency components such as ones using epitaxial planar construction.
b. Use low impedance, majority carrier devices to minimize the effect of the radiation induced excess carriers.
- (6) Select capacitors which have low leakage and high dielectric constant. The ceramics, for example pzt, have very high dielectric constants.
- (7) The use of insulation or potting should be balanced between the increase in secondary emission produced and the lowering of the ionization leakage paths.
- (8) Hermetically sealed units with air, oxygen, or other electron attaching gas inside will help to harden the system to radiation.

III. GENERAL SUGGESTIONS FOR CIRCUIT DESIGNERS

- (1) Design and use of circuits with low impedances.
- (2) Use double-diffused thin-based diodes and transistors.
- (3) Include circuits with high gains in anticipation of attenuated outputs, transform single stage high gain circuits to multistage low gain circuits to minimize saturation.
- (4) Use shielding and potting if justified.
- (5) Eliminate air ionization sore spots by sealing circuits, conductors, junctions, and component terminations.

AREAS OF CONCERN

- (1) Leakage of reverse biased junction in semiconductor devices.
- (2) Discharge of capacitors.
- (3) Secondary electron emission from the entire system.
- (4) Leakage in ionized gases.

PART XVI
TECHNICAL APPENDIX NO. 1
FUNDAMENTAL PRINCIPLES AND UNITS

TECHNICAL APPENDIX NO. 1
FUNDAMENTAL PRINCIPLES AND UNITS

This section contains information on the nature of the radiation and pressure environments due to a nuclear weapon. The various types of nuclear radiation and a description of the pressures produced by the blast are given. Definitions of quantities and units which are useful in radiation effects are given.

The purpose of this section is to acquaint the reader with the fundamental concepts which serve as an introduction to the treatment of nuclear radiation effects on electronic systems, components, and materials.

DEFINITION OF RADIATION

Radiation is the emission and propagation of energy through space or through matter in the form of waves, such as electromagnetic, sound, or elastic waves. The utilization of nuclear energy has introduced an extension of this definition to include fluxes of energetic nuclear and atomic particles in addition to waves. This extension becomes natural when we consider that electromagnetic waves can be treated as a flux of massless neutral particles, photons, whose energy is related to the wave frequency by the wellknown relation,

$$E = hv$$

where E is the energy, h is Planck's constant (6.62×10^{-27} erg-sec), and v is the frequency. Similarly, quantum mechanics requires that a particle be treated as a wave whose wavelength is given by,

$$\lambda = \frac{h}{mv}$$

where λ is the wavelength, v is the particle velocity, and m is its mass. Thus, we can use either the wave or the particle concept in making a general definition of radiation.

The problem of the effects of radiation on matter calls for the particle definition. We can, therefore, define radiation as a flux of particles characterized by a certain energy or distribution of energies and a certain mass (and other intrinsic properties, such as charge, spin, and magnetic moment which, together with mass, uniquely identify the particle if the particle does have a mass.

UNITS AND DEFINITIONS

Description	Rest Mass (gram)	Electrical Charge (coulomb)	Rest Energy (Mev)	Alternate Description
electron	9.108×10^{-28}	-1.6×10^{-19}	0.511	beta particle (β^-)
positron	9.108×10^{-28}	$+1.6 \times 10^{-19}$	0.511	β^+
proton	1.672×10^{-24}	$+1.6 \times 10^{-19}$	938.2	hydrogen nucleus
neutron	1.675×10^{-24}	0	939.5	
alpha particle	6.646×10^{-24}	$+3.2 \times 10^{-19}$	3.757×10^3	helium nucleus

Energy

The most commonly used unit of energy for individual particles is the electron volt. This is the energy that a particle with the charge of one electron (1.6×10^{-19} coulomb) acquires after passing through a potential difference of 1 volt.

$$\begin{aligned} \text{One electron volt} &= 1.6 \times 10^{-12} \text{ ergs} = 1.6 \times 10^{-19} \text{ joules} \\ &= 3.82 \times 10^{-20} \text{ gram-calories} \end{aligned}$$

$$1 \text{ Mev} = 1 \text{ million electron volts} = 1.6 \times 10^{-6} \text{ ergs}$$

$$1 \text{ Kev} = 1 \text{ thousand electron volts} = 1.6 \times 10^{-9} \text{ ergs}$$

Gamma (γ) Ray

A Gamma Ray is a quantum of electromagnetic radiation emitted by a nucleus. The ranges of energies are roughly 10 Kev to 10 Mev. γ -rays differ from x-rays or radio waves only in frequency or energy ranges.

X- Radiation

An x-ray is a quantum of electromagnetic radiation emitted by the atom.

Threshold Energy

The minimum amount of excitation energy required to produce a given reaction.

Neutrons

Neutrons are neutral particles having a mass slightly greater than a proton. They are unstable, decaying to protons and electrons with a half-life of about 12 minutes. The decay of neutrons involves a spectrum of beta rays whose maximum energy is 0.75 Mev.

Neutrons are commonly divided according to their energies into sub-classifications as follows:

Fast neutrons	greater than 0.1 Mev
Slow neutrons	less than 0.1 Mev
Epithermal	0.1 ev to 100 ev
Thermal	in a range about 0.025 ev

Curie

This is a unit used for giving the strength of a radioactive source in terms of the number of disintegrations in the source per second. One curie is equal to 3.7×10^{10} disintegrations per second. It is to be noted that each disintegration may produce one or many photons and particles.

Roentgen

Represents the quantity of x-rays or γ -ray radiation which produces 1 electrostatic unit (esu) of charge (1 coulomb = 3×10^9 esu of charge) of either sign, including all secondary ionization, in lcc of dry air at 0° C and 760 mm Hg. pressure. The mass of lcc of dry air at 0° C and 760 mm Hg. is 0.001293 gram. One esu of charge corresponds to 2.08×10^9 ion pairs, (one positive charge and one negative charge, e.g., an electron and the residual atom). Each ion pair requires 32.5 ev of energy to form it; therefore,

$$1 \text{ roentgen} = \frac{1 \text{ esu of charge}}{0.0013 \text{ g of air}} \times \frac{2.08 \times 10^9 \text{ ion pairs}}{\text{esu of charge}} \times \frac{32.5 \text{ ev}}{\text{ion pair}}$$

$$\times \frac{1.6 \times 10^{-12} \text{ erg}}{\text{ev}}$$

or 1 roentgen = 83.8 ergs absorbed/gram of air.

For gamma rays with an energy of 1 Mev, we can approximately express the flux in terms of roentgens per unit time.

$$1 \text{ roentgen/hr} = 5 \times 10^5 \text{ gammas/cm}^2\text{-sec.} = \frac{\text{Mev/sec}}{1.9 \times 10^{10} \text{ r}^2}$$

The roentgen is a measure of air exposure dose.

Although the roentgen was originally defined as a measure of the absorption of X- and gamma rays in air, the concept involved in the definition has been extended to define other units of radiation which are called relative biological effectiveness (RBE), the Roentgen Equivalent Man, REM.

RBE

Biological damage depends not only on the rate or total dose, but also upon the specific ionization along the path of the incident particle. Particles with higher density of ionization generally have greater biological effectiveness.

Relative Biological Effectiveness

<u>Particle</u>	<u>RBE</u>
x-rays, gamma rays	1
Protons and beta particles	5
Alpha particles	10
Fast neutrons	10
Thermal neutrons	5

In terms of the Relative Biological Effectiveness, the REP and REM are related by,

$$\text{REM} = \frac{\text{REP}}{\text{RBE}}$$

Rad

Unit of absorbed radiation dose equivalent to an energy deposition of 100 ergs/gm. The Rad is a measure of the energy imparted to matter by ionizing radiation per unit mass of irradiated material at the place of interest.

Erg/cm²-gm

Unit of radiation equivalent to 1/100 of a Rad.

Flux

Number of particles crossing a unit area per unit time. The commonly used unit of flux is particles/cm²-sec. Integrated flux after an exposure of time T is equal to the total number of particles which have traversed a unit area in the time T.

NV

For neutrons, flux is generally given as NV, where N is the number of neutrons per cm³, and V is the average velocity of the neutrons.

NVT

Integrated neutron flux. Total number of neutrons through 1 cm² of area in time T.

Gamma Flux

Usually given in photons per square centimeter second. The relation between this and dose rate expressed in roentgens per hour depends upon the energy of the radiation and the absorbing material. For monochromatic gamma radiation or neutrons, the relationship is shown in Figure 1 and 2. If the radiation is not monochromatic, one should integrate the product of conversion factor and spectral intensity per unit energy to obtain a suitable weighted factor. As noted above, for a fission gamma spectrum the factor is approximately,

$$1 \text{ r/hr} = 5 \times 10^5 \text{ gammas/cm}^2\text{-sec.}$$

All gamma exposures are generally reported in terms of the field, with units being ergs per gram referenced to carbon ergs g^{-1} (C). Factors used in converting reported gamma exposures to ergs g^{-1} (C) are as follows:

<u>To Convert</u>	<u>To</u>	<u>Multiply By</u>
Ev g^{-1}	ergs g^{-1} (C)	1.6×10^{-12}
Roentgen	ergs g^{-1} (C)	87.7
Rep	ergs g^{-1} (C)	84.6
Rad (tissue)	ergs g^{-1} (C)	90.9
Rad (water)	ergs g^{-1} (C)	90.0
Mev cm^{-2}	ergs g^{-1} (C)	4.5×10^{-8}
Mev cm^{-2}	ergs g^{-1} (C)	4.5×10^{-8}

Roentgen Equivalent, Physical (rep)

The quantity of any type of ionizing radiation which results in the absorption in a substance of 83.8 ergs/g.

Roentgen Equivalent, Man (rem)

The amount of any type of ionizing radiation which will produce the same biological effect as that produced by one roentgen of x-rays or γ -rays at 400 Kev.

THE FISSION REACTION

Fission reactions can occur when neutrons or γ -rays are incident on a nucleus. The type of reaction considered here will be neutron-induced fission because of its practical applications in weapons. Some of the nuclei used in neutron-induced fission together with the fission thresholds are given in Table I⁽¹⁾.

TABLE I

Nucleus	Th ²³²	U ²³³	U ²³⁴	U ²³⁵	U ²³⁶	U ²³⁸	Np ²³⁷	Pu ²³⁹
Neutron-Fission Threshold (Mev.)	1.3	0	0.4	0	0.8	1.2	0.4	0

Table I shows that U^{233} , U^{235} and Pu^{239} have negative thresholds and, therefore, can undergo fission with thermal neutrons since little excitation energy is required. U^{235} is the most commonly used nucleus in fission.

When a thermal neutron strikes a U^{235} nucleus, the resultant nucleus, U^{236} , is highly excited and breaks up into normally two highly excited fission fragments.

Table II gives some properties of these fission fragments. A is the atomic weight of the nucleus undergoing fission.

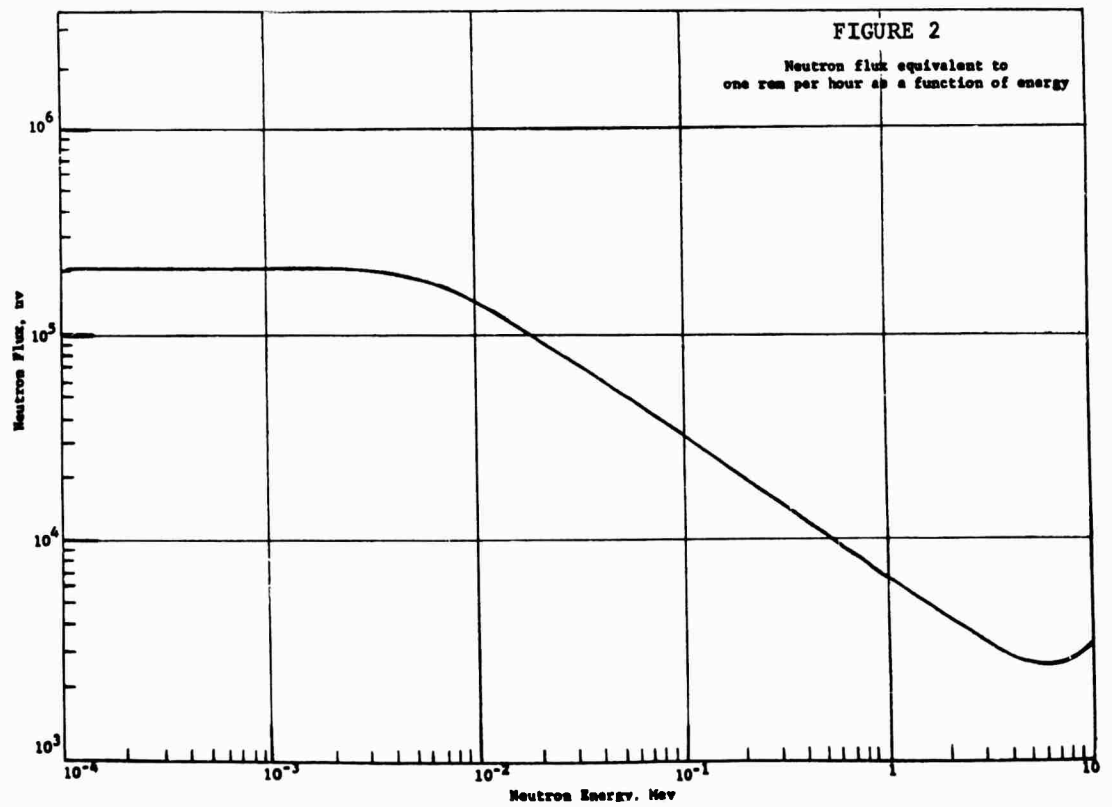
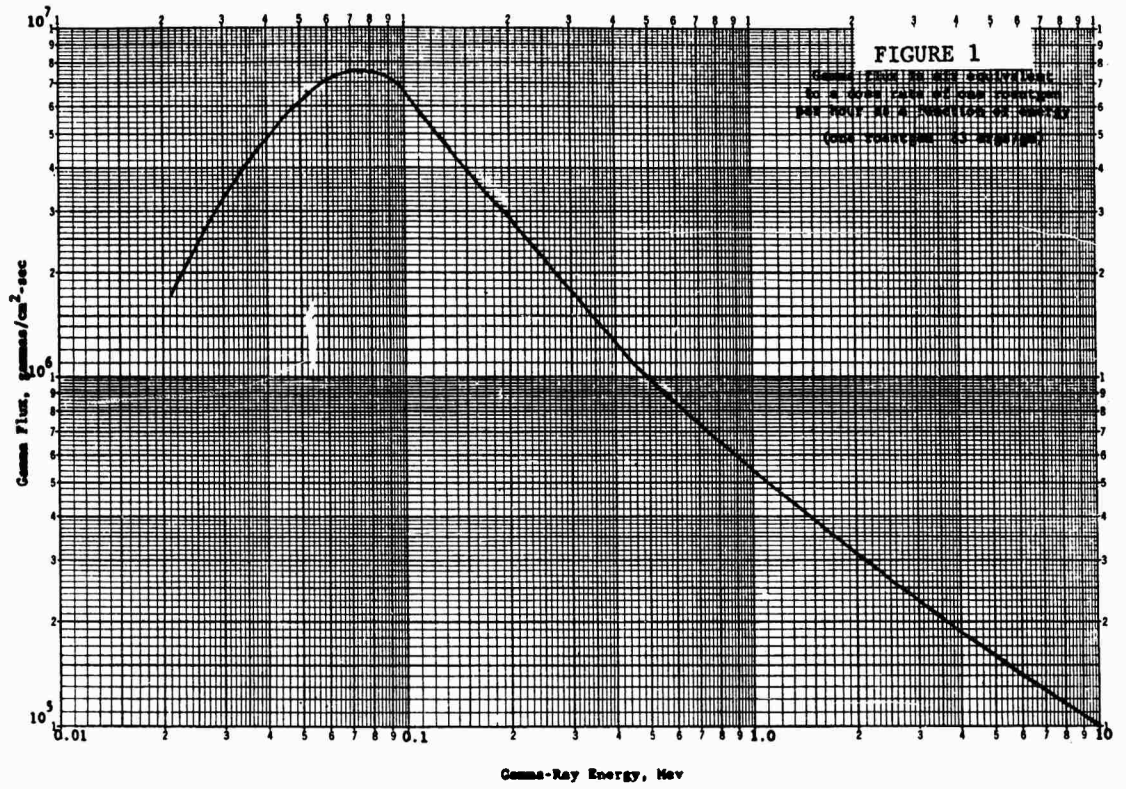

TABLE II

Property	Lighter Fragment	Heavier Fragment
Range of atomic weight	about 72 to A/2	A/2 to about 158
Average excitation energy (Mev)	11	9
Kinetic Energy (Mev)	100	65

The excited fission fragments will most probably emit 2 or three neutrons, followed by the emission of about 5 gamma rays. The neutrons and gamma rays are emitted within about 10^{-14} sec after the formation of the fission fragments and are termed prompt radiations. Subsequent decay of the fission products produce about 7 gamma rays and 7 beta rays, and these are termed delayed radiations. Table III shows the radiations emitted as a result of fission.

TABLE III

Form of Energy	Total Energy (Mev)
Kinetic energy of fission fragments	167 ± 5
Energy of prompt gamma rays	6 ± 1
Kinetic energy of prompt fission neutrons	5
Fission Product Decay	Total Energy (Mev)
γ - ray	6 ± 1
β - ray	8 ± 1.5
Neutrinos	12 ± 2.5
Total Energy per Fission	204 ± 7

About 80% of the total energy per fission is in kinetic energy of the fission fragments and the remainder is in kinetic energy of the neutrons and radiation. The energy spectrum of the prompt neutrons is shown in Figure 3, and the gamma rays emitted within 1 μ sec from the decay of the fission products is shown in Figure 4. The average energy of these delayed gamma rays is about 0.9 Mev.

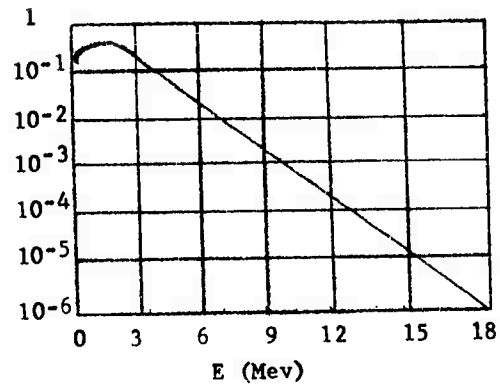

FIGURE 3

Fraction of neutrons per Mev interval from thermal neutron fission of U²³⁵.

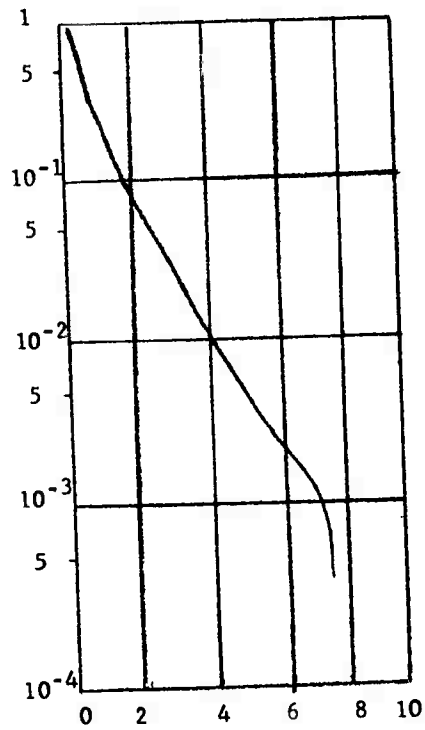

FIGURE 4

Gamma-Ray Energy (Mev)

The energy spectrum of the prompt gamma rays is not known, but their average energy is about 1 Mev.

As the prompt neutrons and gamma rays, and the delayed gamma rays, (all emitted within 1 μ sec after fission) are emitted in the atmosphere, they will interact with the atmospheric gas. Since the neutrons have a spectrum of energies, Figure 1, they have a corresponding spectrum of velocities and, therefore, will arrive at a target in a large interval of time; while the gamma rays (which have the same velocities, but have a spectrum of energies), will arrive in a short pulse.

The fission fragments and the β rays are absorbed quickly in the bomb debris and in the atmosphere. They do not contribute to the radiation within 1 μ sec after blast. Therefore, as far as radiation rates are concerned, the prompt and delayed gamma radiation, which are unscattered in the atmosphere are important because they arrive at a target in the form of a pulse. The width of this pulse is approximately less than 10^{-6} sec. At a range where the integrated dose from the gamma rays is 100 roentgen, the peak gamma dose rate in the pulse can be as high as 10^8 roentgen/sec.

Gamma rays can be absorbed in the atmosphere. The nature of the interaction of x- and gamma rays with matter is very strongly a function of its energy. There are three distinct types of interactions with matter.

Photoelectric Effect

A process where a gamma ray interacts with the most tightly bound electrons in an atom, knocking out the electron and absorbing the photon in the process. This process is predominant for low-energy gamma rays. Figure 5 gives a pictorial explanation of this effect. The range of energy where the photoelectric process is dominant is less than 0.5 Mev. The complete absorption comes about because a gamma ray cannot give up its entire energy to a free electron if momentum is to be conserved. It is identical to the process that is utilized in photoelectric cells. The gamma ray and its energy disappear, and an electron is ejected from one of the electron orbits of the atom. The kinetic energy of the electron is equal to the difference between the gamma ray energy and the binding energy, B , of an electron in this orbit. A very small amount of energy,

(less than $\frac{M_e}{M_{\text{atom}}} E_\gamma$) is imparted to the atom as a whole.

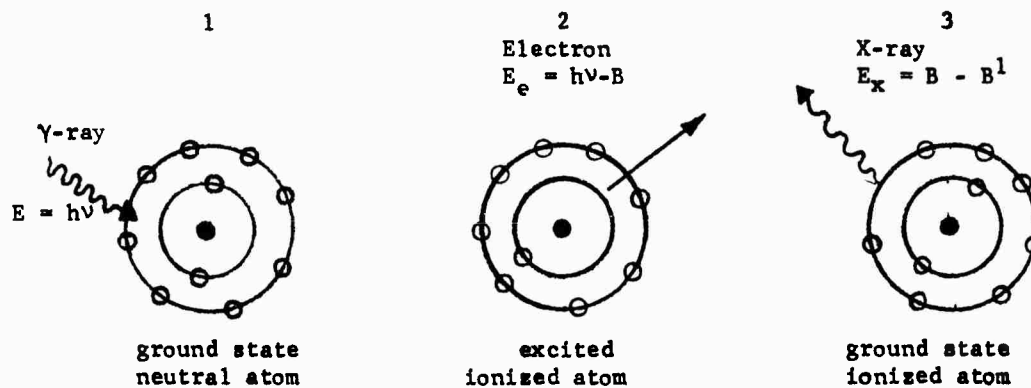

FIGURE 5: THE PHOTOELECTRIC PROCESS

If the electron is emitted from an inner orbit of the atom, an electron from an outer orbit will promptly jump into the recently vacated inner orbit with the simultaneous emission of an x-ray. The energy imparted to the atom as a whole is not sufficient to displace it from its equilibrium position unless the energy of the photon is of the order of 25 A Kev or greater, where A is the mass number of the atom. At this energy, the photoelectric process is not effective in producing atomic displacements.

Compton Effect

This effect is, in general, smaller than the photoelectric effect in the low-energy region, but it extends to higher energies and is dominant to the region 200 Kev to 2 Mev. The Compton effect is a simple collision between the gamma ray (with energy E and momentum $\frac{E}{c}$) and an electron, as shown in Figure 6, in which the electron is ejected from the atom.

Electron
 $E_e = h\nu - h\nu^1$

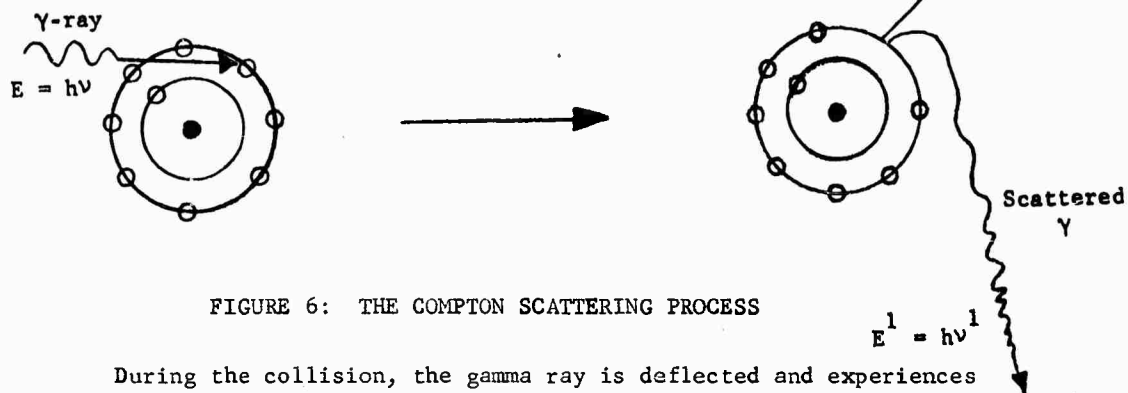

FIGURE 6: THE COMPTON SCATTERING PROCESS

During the collision, the gamma ray is deflected and experiences a change in frequency that is dependent on the angle of deflection. The energy lost by the gamma ray is transferred to the scattered electron. In this case, practically no energy is transferred to the atom from which the electron is ejected. The Compton process is completely ineffective in producing direct displacements of atoms in crystals. X-rays will, however, be subsequently emitted if the ejected electron came from an inner orbit.

Pair Production

If the gamma ray has an energy greater than 1.02 Mev, it may be completely annihilated in passing near a nucleus, as shown in Figure 7. Almost all of its energy is converted into the masses and kinetic energies of an electron-positron pair that is created. A small fraction of the gamma energy is imparted to the nucleus. This energy is often sufficient to cause a lattice displacement of the atom to which the nucleus belongs. In this case, no x-rays are directly associated with the effect.

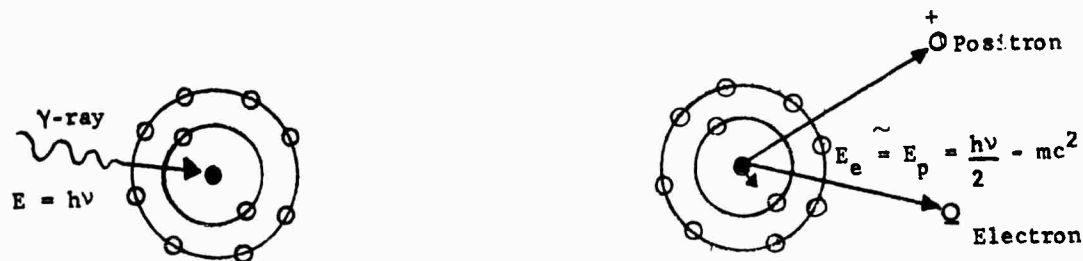
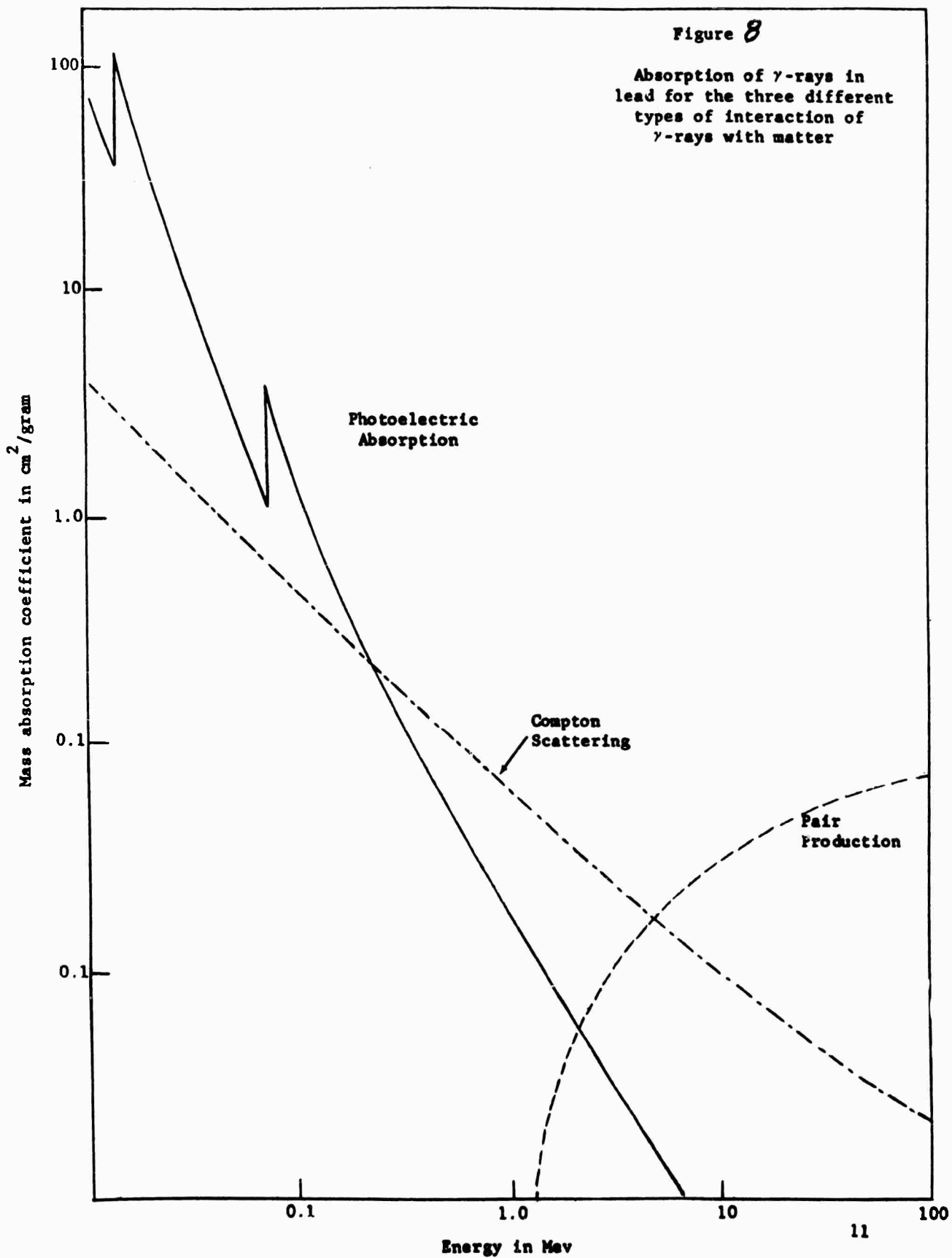

FIGURE 7: PAIR FORMATION



The absorption in matter of a beam of gamma rays results from a combination of these three effects (Figure 8). A gamma ray either gives up all its energy in one interaction or it is strongly deflected from its path, as in the Compton effect, and is thereby lost from the beam. This situation results in the well-known absorption law,

$$N = N_0 \exp \left(-\frac{X}{L(E,Z)} \right)$$

where X is the amount of material (in gm/cm^2) traversed by the beam, and L (in gm/cm^2) is a function of the average atomic number of the material and the energy of the gamma ray.

In all three processes, the gamma ray is either completely absorbed (photoelectric and pair production) or is scattered from its initial direction (Compton effect). Therefore, the Compton-scattered gamma rays, in addition to the unscattered gamma rays from the blast, must be investigated in computing the dose rate. It will be shown that, since the unscattered gamma rays arrive at a target in a pulse of approximate width, 10^{-6} sec, only a small portion of the Compton-scattered gamma rays will contribute to the pulse within this 10^{-6} sec. This can be seen in the following way: Since the pulse of unscattered gamma rays arrive at the target in a pulse of width 10^{-6} sec, those scattered gamma rays which eventually reach the target will arrive after the pulse if they travel a distance greater than the unscattered gamma rays. The distance is about 3×10^{10} cm/sec $\times 10^{-6}$ sec = 30,000 cm. These scattered gamma rays will not significantly contribute to the gamma dose rate in the pulse.

CHARGED PARTICLES

Since charged particles can, in general, be eliminated by a reasonable amount of shielding, we are not concerned with primary radiation fields of charged particles in the problem of radiation damage. However, the damaging effects of gamma rays and fast neutrons, which are difficult to shield out, are entirely due to the generation of energetic secondary charged particles. Secondary electrons and positrons are the damaging agents of gamma radiation.

Fast neutrons are very effective in producing energetic protons in organic materials.

Common to all charged particles passing through matter is the excitation and ionization of atoms which they produce along their path. The number of excited atoms and ion pairs per unit distance varies with the particle velocity and its charge and the type of material through which it is traveling. As a consequence of the continuous small energy losses in ionizing atoms along its path, a charged particle is stopped after a definite amount of material has been traversed. This amount, expressed in g/cm^2 , is called its range.

Apart from ionization, the magnitudes of other interactions, resulting in specific types of damage to material, are quite different for electrons and heavy charged particles, such as protons and alpha particles.

a. Beta Rays or Electrons and Positrons

Energy loss due to ionization for electrons in the 1 Mev energy region is about 2 Kev per mg/cm^2 of path, and the number of ion pairs is of the order of 100 per mg/cm^2 . Electrons or beta rays passing through matter are often strongly deflected from their original path on passing close to a nucleus and in electron-electron collisions. The acceleration of charge accompanying such deflections results in the emission of a spectrum of gamma rays whose maximum energy is equal to the energy of the electrons. Such gamma radiation is present wherever there are high-energy electrons, and is commonly called Bremsstrahlung. The relative importance of the Bremsstrahlung process for energy loss by high-energy electrons passing through matter is of the same order as the ionization loss for electron energies greater than 10 Mev in high Z matter. For low energy electrons, it can be neglected.

In their interaction with matter the energy of gamma rays is totally or partially converted to the energy of electrons, which are then effective in causing damage to materials. The converse is true for electrons; the Bremsstrahlung process enables the energy of electrons to be converted to gamma rays which may escape or cause damage in regions outside the range of the primary electrons.

b. Heavy Charged Particles

Energy loss due to ionization for 1 Mev protons is about 0.3 Mev per mg/cm^2 of path, and the number of ion pairs is about 10,000 per mg/cm^2 . The energy loss by heavy charged particles traversing matter is caused primarily by ionization.

Occasionally, the heavy charged particle will pass close to a nucleus and impart sufficient energy to displace it from its equilibrium position. This is an important method of displacing atoms from normal positions. Still less often, it will experience a head-on collision with a nucleus. In this case the struck nucleus will be ejected with a velocity such that it can lose some of its orbital electrons and, hence, produce a track of ionization until it is slowed down to a velocity at which it can become neutral again. The last part of its passage through matter when it is neutral is effective only in producing thermal agitation, which is often referred to as a thermal spike.

NEUTRONS

A. Fast Neutrons

Since neutrons are neutral particles, they are not effective in producing ionization directly. If their energy is of the order of $10 A^2$ Kev or greater, where A is the mass number of the medium, they may impart a sufficient amount of energy to an atom, by colliding

TABLE IV
 TYPES OF RADIATION AND EFFECTIVENESS
 IN CAUSING DAMAGE TO MATERIALS

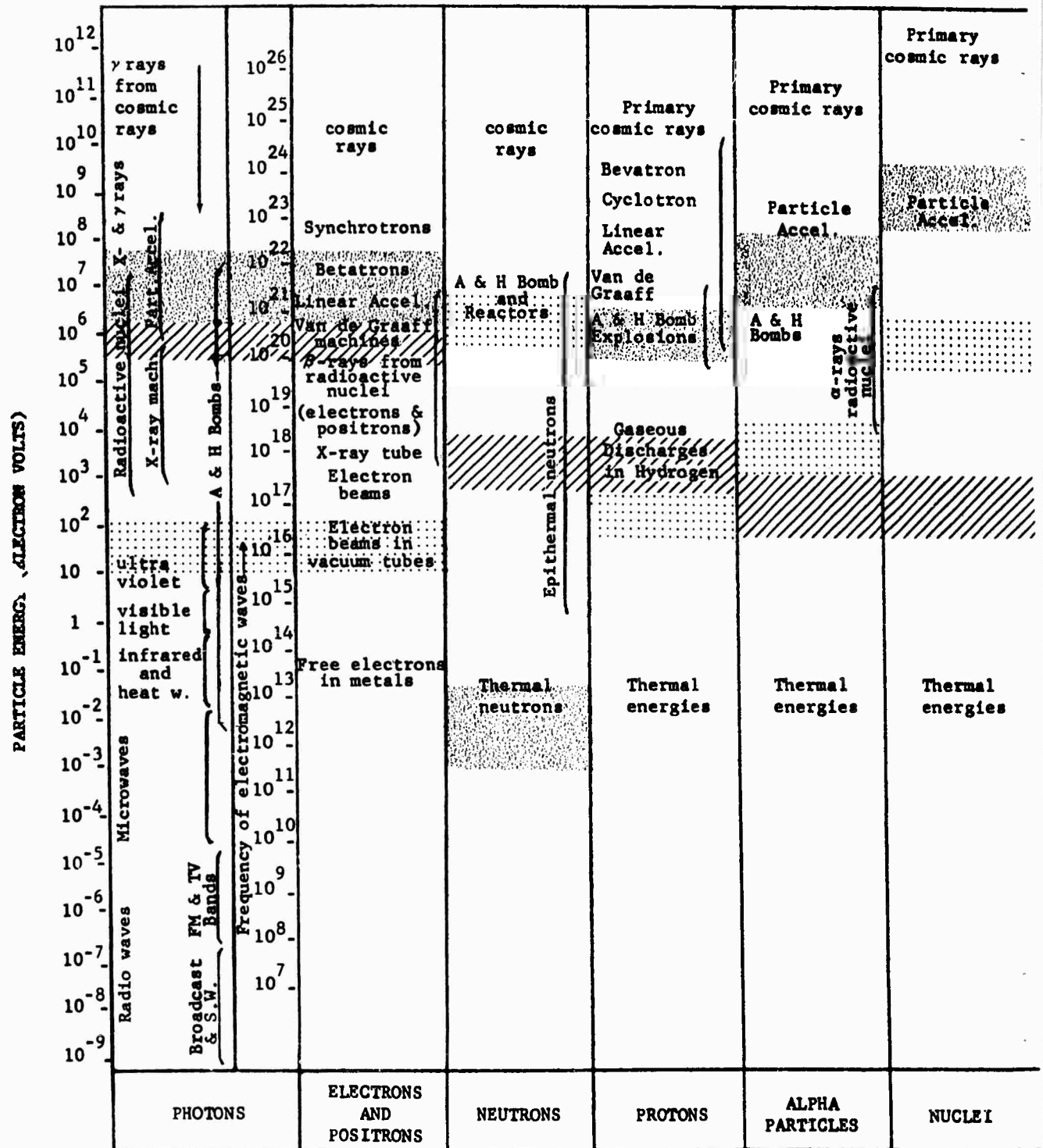

Approx. Threshold for Producing Ionization

Approx. Threshold for Atomic Displacements

Approx. Threshold for Nuclear Transmutations

with a nucleus along their path, to eject it from its equilibrium position, stripped of some of its orbital electrons. The resulting energetic heavy ion will produce ionization until it is slowed down to a velocity at which it recaptures the missing electrons and becomes neutral again. The extent of this indirect ionization by neutrons is small, relative to the extent of non-ionizing displacements and nuclear reactions. Hence, even fast neutrons of the order of 2 Mev are not efficient as ionizing particles in media other than organic materials. The absence of the ionization process makes a fast neutron flux a very penetrating radiation.

B. Thermal Neutrons

Thermal neutrons produce no ionization and displacements directly. A thermal neutron will either be captured by a nucleus in the material, a process which is accompanied by the emission of one or more high energy gamma rays (total energy of the order of 8 Mev), or eventually decay (half-life about 12 min.) to a proton with the emission of an energetic electron (0.75 Mev maximum). In many cases, capture of a thermal neutron by a nucleus will result in an unstable nucleus which decays by beta emission. The final nucleus in this case has no longer the same atomic number. This is called transmutation by neutron capture, and it gives rise to impurity atoms. Since both capture and decay of neutrons are usually followed by the emission of ionization radiations, thermal neutrons are particles which give rise to ionization indirectly.

Thermal neutrons are very readily absorbed by cadmium. Each absorption of a thermal neutron gives rise to several gamma rays; therefore, shielding against thermal neutrons must also include gamma shielding.

DAMAGING RADIATION

The types of radiation of interest are those which interact strongly with matter, causing damaging effects such as the following:

- (1) Ionization of atoms in the material
- (2) Displacement of atoms in a lattice
- (3) Transmutations of atomic nuclei

The energy thresholds for the production of these effects will depend on the type of radiation. Damaging radiation is that which has particle energies greater than the thresholds for any one of the effects mentioned. Table IV gives a general picture of damaging radiations and also shows the relation between such radiation and other familiar types of radiation.

INTERACTIONS OF RADIATION WITH MATTER

General

A high-energy particle (photon, electron, proton, etc.) will interact with an atom as a whole, or with the individual electrons or atomic nuclei along its path. The interaction will, in general, result in the transfer of energy and momentum to the region of matter that the particle traverses. The energy transferred will be consumed in the form of work done on the following primary effects.

a. Atomic Excitation and Ionization

One or more electrons of an atom will be excited to higher energy orbits or, if the energy imparted is sufficient, an electron will be ejected from the atom into the surrounding region, leaving an ionized atom. In a solid material, this constitutes the creation of an electron and hole pair.

b. Thermal Agitation and Displacement of Atoms

An atom can either be set in vibration about its equilibrium position in a crystal or, if the energy transferred is great enough, be broken loose from its equilibrium position and moved into another region of the lattice. The former will result in the temporary heating of a localized region. The

latter will cause the appearance of two imperfections in the form of a vacancy and an interstitial atom, in addition to localized heating.

c. Nuclear Excitations and Transmutations

The nucleons (protons and neutrons) of a nucleus can be excited to higher energy states (or orbits). The de-excitation will be accomplished by the emission of gamma rays or energetic electrons or nucleons. The final nucleus may no longer belong to the same element, thus constituting an impurity atom. This category also includes the case where the incident particle is captured in the target nucleus, imparting all its kinetic energy to excite the nucleus.

Immediately following these primary effects, the affected region becomes a source of secondary radiation (electrons, photons, and energetic ionized atoms), causing similar processes to take place. This will continue until all the energy transferred by the original high-energy particle is distributed among a large number of discrete, small energy changes of state of the material. For solids, these changes of state may be classified in the following manner:

PRESSURE ENVIRONMENT

The explosion of a nuclear weapon produces a blast wave consisting of a varying overpressure and a varying dynamic pressure. The overpressure is the pressure in excess of the ambient atmospheric pressure and is associated with the blast wave.

Figure 9 shows how the overpressure varies within a few seconds after the blast wave has reached a certain point (arrival time).

The dynamic pressure follows directly behind the blast wave and is associated with wind velocity and the density. The dynamic pressure falls to zero later than the overpressure because of the momentum of the air behind the wave front. The overpressure then becomes negative (in this region called underpressure) and the blast wave then reverses direction and proceeds toward the blast. Table IV gives some values of corres-

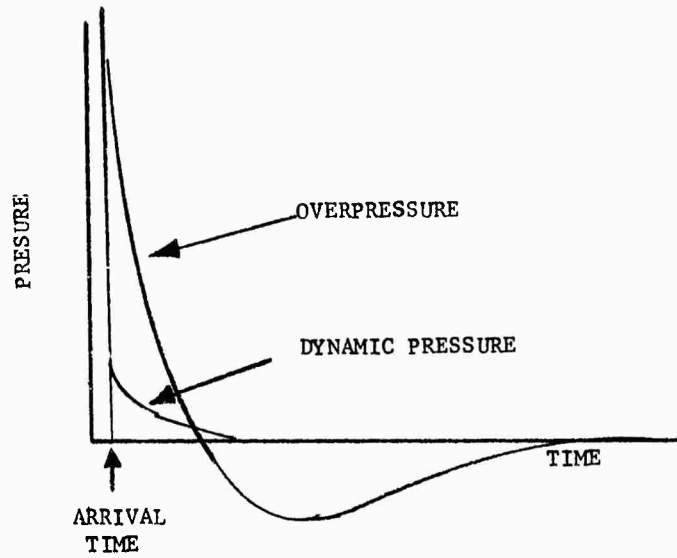

FIGURE 9⁽³⁾ VARIATION OF OVERPRESSURE AND DYNAMIC PRESSURE WITH TIME

ponding pressures and wind velocities for an ideal blast wave front at sea level.⁽³⁾

TABLE IV

Peak Overpressure Pounds/in ²	Peak Dynamic Pressure pounds/in ²	Maximum Wind Velocity miles/hour
250	330	2080
150	223	1778
100	123	1414
72	80	1170
50	40	940
30	16	670
20	8	470
10	2	290
5	0.7	160
2	0.1	70

The peak overpressure and peak dynamic pressure are the maxima of these values reached at a given location. The overpressure tends to collapse a structure and the dynamic pressure tends to carry a structure with it.

CONCLUSION

Before an evaluation of radiation environment from the blast can be made, information concerning the maximum peak overpressure and peak dynamic pressure the target can tolerate must be obtained. Then, at these overpressures and dynamic pressures, the gamma radiation rates can be calculated and the electronic systems and materials be designed to operate in this radiation environment.

REFERENCES

1. A. M. Weinberg and E. P. Wigner, "The Physical Theory of Neutron Chain Reactors", Chicago, The University of Chicago Press, 1959, p. 106.
2. H. Soodak, ed., Reactor Handbook, Second Edition, Vol. III, Part A, New York, Interscience Publishers, 1962, p. 16.
3. S. Glasstone, ed., "The Effects of Nuclear Weapons", Revised Edition, U. S. A. E. C., (April 1962), Chapter III.

Page 146

PART XVII
APPENDIX II
TECHNICAL NOTES ON MATERIALS

APPENDIX II
TECHNICAL NOTES ON MATERIALS

RADIATION EFFECTS ON MATERIALS

The PHOENIX System is interested in radiation effects on materials only as these effects are related to operation of the electronics. In general, radiation at levels at which electronic systems, such as the PHOENIX System would operate, does not affect the physical properties of the materials; but dose at levels, which do not affect the physical properties of a material, will effect the electronics.

Radiation effects on materials are usually classified as to permanent and transient. This classification is made with respect to whether the effect produced by the radiation remains after the radiation field is removed. In the case of electronic circuits, however, a transient effect is usually defined as one which is on the same order as circuit time constants, while a permanent effect is one which is long compared to the circuit time constants. In most cases, the transient radiation effect is the more important in electronic circuits, since these circuits are very radiation sensitive to a high short pulse of radiation; while materials, on the other hand, usually require a larger dose to affect their physical properties. However, transient effects are important in materials when they are employed in circuit applications in components because of the ionization effects produced.

TRANSIENT RADIATION EFFECTS

Transient radiation effects on dielectric materials are almost entirely due to the gamma component of nuclear radiation. The primary mechanism by which transient radiation effects are produced is electronic excitation and ionization.

Very little work has been done in the area of transient radiation effects on insulating materials - potting compounds, coatings, insulators, and circuit boards. The work done in this area has been directed toward transient radiation effects on passive parts. The different materials used in these devices have been studied.

In general, pulsed radiation will not cause permanent damage to materials. The effects of pulsed radiation predominates in electronic devices and circuits.

Inorganic materials will not exhibit a significant change of dielectric properties after exposure to pulsed radiation. The transient effects occurring are an increase in conductivity and a decrease in breakdown potential. The magnitude of the change will depend on the intensity of the pulse, the ionization potential of the material, and the relaxation time of the excess carriers generated by the radiation.

Organic materials also exhibit a transient increase in conductivity and a decrease in breakdown potential; however, ionization results in chemical reactions which can produce additional permanent effects. These consist of changed dielectric values and increased sensitivity to environmental interactions. In those materials which evolve an appreciable volume of gas upon irradiation, the expansion of the material will change the capacitance value when it is used as the dielectric in a capacitor.

PERMANENT RADIATION EFFECTS

Since the amount of radiation required to seriously change the physical properties of a material is quite high in the field of radiation effects on materials, all of the effects of interest are permanent. It must be pointed out, however, that transient ionization effects on materials caused by high dose rates, while they do not appreciably affect the physical properties of materials, per se, they do cause important effects on electronic circuits. These effects are not considered to be effects on materials, but component or circuit effects. Therefore, these considerations are beyond the scope of this report. For most materials the threshold for radiation effects is in the order of 10^6 rads or higher (except for a relative few). This type of damage is classified as permanent since it does not anneal out at room temperature (except in a few isolated cases) in a relatively short time.

In the following sections of this report a brief summary of the radiation affects on materials of interest to electronic design engineers is

included. These summaries contain only a brief discussion of the major radiation effects and limits of serviceability of the materials. For detailed information one should first review the series of reports published by the "Radiation Effects Information Center", Battelle Memorial Institute, Columbus, Ohio.

ELASTOMERS

Elastomers react in the following manner to radiation:

- (1) Post-irradiation physical and dynamic mechanical tests indicate that no problems are encountered for a radiation dose below 10^5 rads for butyl rubbers and below 10^6 rads for all other elastomers.
- (2) Butyl rubber loses practically all utility in the 10^5 to 5×10^6 rads range.
- (3) All elastomers except butyl rubber in the 10^6 to 10^7 rad range progressively lose from 5% to 25% of their original tensile strength and ultimate elongation.
- (4) These rubbers in the 10^7 to 10^8 rad range lose progressively from 25% to 75% of their original tensile and elongation values.
- (5) At about a dose of 5×10^8 rads, these rubbers retain only about 10% or less of their original stress-strain values.
- (6) New elastomers under development may extend the 25% damage threshold for tensile strength and ultimate elongation to 10^9 rads, and they show a promise of having an improved thermal stability. These compounds are generally the highly aromatic poly (vinylester) and poly-condensate rubbers.
- (7) Above a dose of 10^9 rads none of the conventional elastomers retain any of their rubberlike characteristics.
- (8) It has been shown that the radiation damage of elastomers in a stressed state is accelerated. The rate of change of the properties of stress-strain is approximately 10 times as fast for rubbers that are radiated under stress as for rubbers that were unstressed during irradiation. Heating will accelerate the radiation damage rate while irradiation in the absence of oxygen will

decrease the radiation damage.

The addition of selected anti rads in the rubber compounds can improve the radiation resistance by a factor of from 2 to 5. A factor of 10 is even possible in some cases.

PLASTICS

Plastic materials react in the following manner to radiation.

Using 20 percent loss of tensile strength as a comparison (flexural strength for epoxies):

- (1) Teflon is affected below 10^6 rads.
- (2) Poly (chlorotrifluoroethylene) is affected at 10^6 rads.
- (3) At a dose of 5×10^6 rads, plasticized poly (vinyl chloride), poly (methyl methacrylate) and linen fabric phenolic are marginal.
- (4) At a dose of 10^7 rads, poly (α -methylstyrene), last polyester, casein poly (vinyl butyral), vinyl chloride-vinylidene chloride copolymer, the cellulose, poly (vinyl-chloride-acetate), and aliphatic cured epoxies are affected.
- (5) Irradiation to a dose of 10^8 rads affects poly carbonate, mylar A, cast phenolics, aromatic and acid anhydride cured epoxies, poly (vinyl formal), rigid poly (vinyl chloride, allyl diglycol carbonate, melamine-formaldehyde and silicone-glass laminate.
- (6) Polyethylene and styrene-acrylonitrile copolymer are useful to a dose of 10^9 rads.
- (7) At a dose of 10^{10} rads, polystyrene, butadiene-styrene copolymer, nylon, aniline-formaldehyde, poly (vinyl carbazole), asbestos filled phenolic, mineral filled polyester, tricallyl cyanurate, and furane are useful.

COATINGS

The following coatings react in the following manner to radiation:

- (1) For doses up to 10^9 rads, the best type of coatings are the phenolics, silicones, alkyenamels and alkyd and epoxy formulations. Halide containing materials are not recommended for use. The halogen degradation products will directly attack the coating, surface and

the electronic components.

- (2) Coatings containing aromatic compounds - polymer bases, plasticizers and dyes - are generally more radiation resistant than the aliphatic compounds.
- (3) Radiation stability of coatings can be improved by including certain organic dyes or a combination of inorganic pigments and carbon in the formulations. Below 10^6 rads there is no difference in the effect of radiation upon pigmented and unpigmented coatings.
- (4) Below 10^5 rads and with temperatures not exceeding 100°F , weather has more effect on coatings than does radiation.
- (5) The effect of radiation upon a coating depends not only upon the surface underneath.

LUBRICANTS

Lubricants react to radiation in the following manner:

- (1) The compound classification of the organic base fluid is the most important single factor in the degree of radiation damage that a lubricant will exhibit. Different base materials can vary as much as a thousand fold in their susceptibility to radiation damage. The different base oils can be ranked in order of decreasing radiation resistance - poly phenyl, poly (phenyl ethers), alky-laromatics, aliphatic ethers, mineral oils, aromatic esters, aliphatic esters, silicones, and aromatic phosphates.
- (2) The radiation resistance of the different base oils can be classified as to dose range:
 - a. From 10^6 and below - no effect due to radiation.
 - b. From 10^6 to 10^7 , methyl silicones, aliphatic diesters and phosphate esters become affected. Certain polymers in solution will start to degrade. Generally, for the other oils, other environmental factors are in control.
 - c. From 10^7 to 10^8 rads, changes in physical properties start to limit the performance of diesters and certain mineral oils. In this dose range, resistance to oxidation and thermal

stability are degraded for all fluids, however, some lubricants are useful while others are of limited value. It should be stated that the resistance to oxidation and thermal stability seems to be the most sensitive properties of the lubricants.

- d. From 10^8 to 10^9 rads, most lubricants have their resistance to oxidation and thermal stability seriously degraded. Within this dose range major changes occur in most physical properties. Aliphatic ethers, aromatic esters, and certain carefully selected mineral oils are usable.
 - e. From 10^9 to 10^{10} rads, the poly phenyl, the poly (phenyl ethers) and the alkylaromatic are usable.
 - f. From 10^{10} rads and above, radiation damage extremely limits lubricants with even the best organic oils. Lamellar solids are the suggested lubricants. (i.e., graphite and molybdenum disulfide)
- (3) The additives which are usually used in lubricants, such as antioxidants, anti-wear, extreme pressure, and anti-foam agents, suffer from radiation damage. This radiation depletion of the agent or the production of radiolysis products, can cause problems in lubricants below radiation dose levels at which the base oils would be degraded.
 - (4) Selective additives can reduce radiation damage in base oils. They are most effective in the more radiation sensitive oils. A better lubricant can be obtained by choosing and using the most stable base stock than by trying to improve a poorer base oil.
 - (5) Radiation will accelerate oxidation, which seriously reduces the effectiveness of a lubricant.
 - (6) Radiation damage is the function of temperature below about 300° F.

GREASE

Greases react under irradiation in the following manner:

- (1) Greases with irradiation first start to soften due to the damage to the structure of the gelling agent, and upon further irradiation will harden due to the cross-linking of the base oil. Generally, conventional greases are usable to about 10^7 rads. Some special products are available which extend this range from 10^7 to 5×10^7 rads. Sodium N-octodecylterephthalamate, silca, and indanthrene blue have been used as a gelling agent to obtain a radiation resistant grease.
- (2) It should be noted that many machine elements have some tolerance for degraded lubricants. In many cases, a system will operate to a higher radiation dose than would be expected from static tests.

GYRO LUBRICANTS AND DAMPING FLUIDS

It can be said that the two major classes of damping and flotation fluids used in gyros, with irradiation, react in different ways. The fluoro carbons tend to decompose and outgas while the silicone fluids cross-link and gel. The limit of serviceability of the fluoro carbons is about 10^8 rads, while the silicone fluids serviceability limit is about 10^9 rads.

The following observations can be made on the radiation effects upon flotation fluids under a dose of 6×10^{14} n/cm² and 7×10^6 rads.:

- (1) An increase in foreign particles will be noted within the system.
- (2) The silicone fluids will tend to gel and usually coagulating to a rubbery solid.
- (3) An increase in corrosiveness will develop from the decomposition of the fluorocarbons.
- (4) Decomposition and loss of elasticity of the organic seals and O-rings will develop.
- (5) An increase in the evolution of gases from the fluorocarbons will develop.