

**UNCLASSIFIED**

**AD** **434538**

**DEFENSE DOCUMENTATION CENTER**

**FOR**

**SCIENTIFIC AND TECHNICAL INFORMATION**

**CAMERON STATION, ALEXANDRIA, VIRGINIA**



**UNCLASSIFIED**

## **DISCLAIMER NOTICE**

**THIS DOCUMENT IS BEST QUALITY PRACTICABLE. THE COPY FURNISHED TO DTIC CONTAINED A SIGNIFICANT NUMBER OF PAGES WHICH DO NOT REPRODUCE LEGIBLY.**

NOTICE: When government or other drawings, specifications or other data are used for any purpose other than in connection with a definitely related government procurement operation, the U. S. Government thereby incurs no responsibility, nor any obligation whatsoever; and the fact that the Government may have formulated, furnished, or in any way supplied the said drawings, specifications, or other data is not to be regarded by implication or otherwise as in any manner licensing the holder or any other person or corporation, or conveying any rights or permission to manufacture, use or sell any patented invention that may in any way be related thereto.

0  
1  
2  
3  
4  
5  
6  
7  
8  
9

4345000

421 4.460

⑬ AFOSR 4-0295

⑨ FINAL TECHNICAL REPORT

AIR FORCE OFFICE OF SCIENTIFIC RESEARCH

from ⑮ 188400

THE UNIVERSITY OF CHICAGO UNIV., Ill.

on

④ PROPERTIES OF SOLUTIONS OF METALS IN MOLTEN SALTS

⑮ Contract No. AF 49(638)-1076

⑩ by

Report prepared by:  
Norman H. Machtrieb  
Principal Investigator

January 26, 1964

DDC  
RECEIVED  
APR 13 1964  
TISIA E

ABSTRACT

Research into the properties of molten salts under ~~2~~

~~Contract No. AF-49(638)-1076~~ followed five lines of investigation

- (1) Nuclear Magnetic Resonance,
- (2) Electrical Conductance,
- (3) Surface Tension,
- (4) Magnetic Susceptibility, and
- (5) Absorption Spectra

Progress has been made in each, and is summarized in the ~~attached report~~

*a*

(1) NUCLEAR MAGNETIC RESONANCE IN MOLTEN SALTS.

We have observed that nuclear magnetic resonance can be studied in molten salts to temperatures of at least 1000°C., and find that it leads to valuable information on the nature of the interaction between cations and anions. Preprint I, entitled "High Temperature Nuclear Magnetic Resonance" has been submitted to Review of Scientific Instruments. It describes two NMR probe and furnace designs which we have constructed and found to function well.

Reprint II, entitled "Nuclear Magnetic Resonance in Molten Salts. I. Chemical Shift of Crystalline and Molten Thallium Salts" has been submitted for publication in the Journal of Chemical Physics. It reports the large chemical shifts in the resonance frequency of the  $Tl^{205}$  nucleus which occur when the anion environment is altered. A downfield shift occurs for  $Tl^{205}$  in both crystalline and molten thallium salts following the progression:  $NO_3^-$ ,  $SO_4^{--}$ ,  $Cl^-$ ,  $Br^-$ ,  $I^-$ . The shift arises from a second-order paramagnetic contribution to the field at the Tl nucleus due to an admixture of its excited states with the ionic ground state. The chemical shift provides a measure of the square of the cation-anion overlap integral, and hence is a measure of the degree of covalency. We believe it may be possible to base a scale of relative covalency in ionic salts upon shifts in the magnetogyric ratio, but much more work must be done to substantiate this.

A downfield shift for  $Tl^{205}$  in thallic salts is also found to be a linear function of the temperature. This is an

important observation, which we interpret as temperature-induced covalency...the enhanced overlap of excited paramagnetic electronic states of cation and anion which is caused by thermal vibration.

We are currently extending nuclear magnetic resonance studies to other systems, including the alkali metal halides, solutions of thallium salts in alkali halide melts, and cadmium halides.

## (2) ELECTRICAL CONDUCTANCE IN MOLTEN IODINE.

We have concluded a study of the electrical conductance of pure molten iodine and of a series of salts dissolved in liquid iodine. It is the basis of Miss Bearcroft's Ph.D. dissertation in chemistry, and will shortly be prepared for publication.

The measurements were made with a high precision Jones Bridge at 2,000 cps in a modified H-type Pyrex conductance cell. The electrodes consisted of tungsten wire spirals which were led into the cell arms through ground glass joints. A third arm of the cell, equipped with a porous glass disc, served the purpose of filtering and mixing the molten iodine solutions when pure dry nitrogen gas pressure or a vacuum was applied. The cell had a capacity of about 400 g of iodine and was heated externally with a salt bath.

The specific conductance of pure liquid iodine at 140°C we found to be  $1.21 \times 10^{-5} \text{ ohm}^{-1} \text{ cm}^{-1}$ , with a temperature coefficient  $dK/dT = -0.00425 \times 10^{-5} \text{ ohm}^{-1} \text{ cm}^{-1} \text{ deg}^{-1}$ . All of the conductance data were referred to 140°C.

## HIGH TEMPERATURE NUCLEAR MAGNETIC RESONANCE

Stefan Hafner and Norman H. Nachtrieb

Institute for the Study of Metals

The University of Chicago

### ABSTRACT

Two designs are described for single coil NMR probes and furnaces with the Varian wide line spectrometer (V-4210) to temperatures up to 1000°C. Their application to molten salt systems is outlined.

Although most of the applications of nuclear magnetic resonance have been made at ordinary temperatures, there are occasions upon which measurements at high temperatures are necessary. Molten salts are a case in point<sup>(1, 2)</sup>. Commercially available spectrometer systems, such as those manufactured by Varian Associates, are limited to temperatures up to 300°C., however. In this article two simple probes are described for use in connection with a Varian wide line spectrometer (e. g. V-4210A) for temperatures up to 750° and 1000°C., respectively. The construction of either probe is simple and inexpensive, and neither makes use of the Varian heating assembly.

Preliminary experiments showed that it is hard to adapt the Bloch crossed coil probe to temperatures above 500°C. because of the difficulty of maintaining precise geometry. This is readily circumvented through the choice of a single coil circuit, though the sensitivity is slightly reduced thereby. An advantage is that more space is available for the heating and cooling systems and for rf shielding. The Varian probe system is replaced by a single coil, furnace, and radiofrequency bridge, all of which are easily constructed.

There are two obvious ways to heat a sample for an NMR measurement: (1) the sample and coil are heated by a furnace that surrounds both, or (2) the sample is heated and the surrounding coil is maintained at room temperature. The maximum temperature of (1) is limited by the melting point of the silver wire used for the coil ( $960^{\circ}\text{C}$ ). Higher temperatures can be reached with (2), but the temperature distribution is less uniform unless the filling factor is drastically reduced. Interruption of the heating current during the NMR measurement is necessary with arrangement (2).

Figure 1 shows a longitudinal section for design (1). The rf coil for measurements at 11.5 to 14 Mc consisted of 14 turns of 0.030" dia. silver wire, set into threads which were internally cut in a thin wall (1.0 mm.) Lava cylinder 25 mm long and 13 mm I.D.. The Q of the coil in its Lava supporting cylinder was 150-200. The heating element consisted of 30 vertical loops of 0.010" dia. platinum wire set into grooves which were milled into a surrounding thin wall Lava cylinder. A brass water-cooled jacket of 40 mm. O.D. contained the furnace and rf coil; its location relative to the modulation coils and bridge is shown in Figure 2. The furnace was heated with storage batteries (24 - 96 volts). At room temperature the resistance of the platinum wire was about 10 ohms. For a sample temperature of  $700^{\circ}\text{C}$ . the furnace required 3.3 amperes at 96 volts, and the mean wire temperature was  $720^{\circ}\text{C}$ . No deformation of the NMR signal could be detected, provided the current supply was well shielded, and no displacement of the signal was observed when heating was interrupted. Sample tubes were made of either Pyrex or Vycor tubing, with a deep re-entrant well to accept a chromel-alumel thermocouple. They were sealed off at a constriction after filling with the appropriate salt and evacuating on a high vacuum line. The weight of salt was calculated to furnish a volume of about  $0.8\text{ cm}^3$  in the molten state, leaving about 1/4 of the space for thermal expansion. The

variation in temperature within  $\pm 1$  cm of the center of the coil was about  $\pm 3^\circ\text{C}$ . This could be reduced to  $1 - 2^\circ\text{C}$ . by reducing the coil diameter to 10 mm., but has the consequence of diminished sensitivity because of the lowered Q of the coil. During measurements it was necessary to remove the thermocouple from its well, since it noticeably affected the magnetic field.

The second design (2) made use of a quartz vessel shown in Figure 3a. The coil, made of 0.040" dia. silver wire, consisted of 14 turns having a length of 25 mm, a diameter of 22 mm, and a Q value of 260. It fitted the quartz vessel closely, but was not cemented to it. The furnace element consisted of a platinum ribbon 24 cm long x 0.002" thick, which formed a vertical loop around the sample tube (Figure 3b). Its width (2 - 4 mm) was varied along the sample tube in order to provide the most uniform temperature distribution. It was important that the cooling water circulate through the vessel jacket without obvious vortices in order to minimize excessive noise. When well adjusted, the cooling water at the highest operating temperature ( $1000^\circ\text{C}$ .) increased the noise level by less than a factor of two, as compared with the noise when the current and water circulation were interrupted. At about  $1000^\circ\text{C}$ . the heating current was 10 amperes at 48 volts. Such a current deformed the signal considerably, but in most cases did not completely obscure the resonance. For resonances which were strong enough to be displayed on an oscilloscope (e. g. for  $\text{Na}^{23}$  in molten NaCl), it was possible to cut off the heating current during the final adjustment to the resonance. When the signal was weak a fast trace with an amplifier-recorder was necessary. For nuclei having strong resonances the filling factor is not of great importance, and the temperature stability could be improved by replacement of the heater ribbon and the two inner quartz tubes by a platinum wound Lava cylinder.

The radiofrequency bridge was of the twin T type, similar to that described by Anderson<sup>(3)</sup>. It has the advantage of providing independent

control of either the absorption or dispersion mode of the resonance signal. The proper choice of bridge constants for optimum signal-to-noise ratio was based upon the work of D. Gheorgiu and A. Valeriu<sup>(4)</sup>.

For probe design (1) the coil resistance increases with temperature, and it is not generally possible to balance the bridge capacitatively over the entire temperature range, 0 - 750°C. For reasons of stability the bridge should have as few variable capacitors as possible, and rebalance during heating is most easily achieved by replacing resistor R' (Anderson's notation) with one of lower value. The following constants were selected for resonance at 14 Mc.:  $C = 7\text{-}45\mu\text{F} + 33\mu\text{F}$ ,  $C_1 = 1\mu\text{F}$ ,  $C_2 = 15\mu\text{F}$ ,  $C' = 7\text{-}45\mu\text{F}$ ,  $C'_1 = 15\mu\text{F}$ ,  $R' = 200\Omega(0^\circ - 500^\circ\text{C})$ . The bridge was connected to the coil and furnace by a 22 cm. length of heavy wall copper pipe. It is necessary to match the bridge output to the Varian (V-4210A) transmitter and receiver inputs (plugs P103 and P201) with coils (e. g. Cambion No. 1536-2-1) having 8 turns of No. 30 enameled wire. These coils were separately shielded from the bridge, as shown in Figure 2. The sensitivity of the circuit is improved if the Varian receiver is replaced by a low noise cascade preamplifier (6DS4 triode) and a sensitive superheterodyne receiver (e. g. Collins 75S).

Modulation of the external magnetic field was provided by two 250 turn coils of No. 30 enameled wire, wound on a pair of 22 cm. diameter aluminum spools. The modulation coils spanned the furnace-probe unit, but to avoid transmission of vibrations to the rf coil, were not directly attached to it. They were connected directly to the Varian 4250 sweep unit.

The NMR furnace and probe assemblies have been used for the study of cation resonances in crystalline and molten salts. Design (1) has been particularly useful for the measurement of chemical shifts in solid and molten thallium salts as a function of temperature<sup>(2)</sup>. Design (2) is proving to be valuable for similar studies on molten alkali halides. Figure 4 shows

recorder traces of the resonance of  $Tl^{205}$  on  $Tl_2SO_4$  at  $700^\circ C$ . (14.0 Mc at 5.7 k. gauss) in the first probe, and of the  $Na^{23}$  resonance in sodium chloride at about  $1000^\circ C$ . (11.5 Mc. at 10.2 k. gauss) in the second probe.

The chief advantage of these probe and furnace designs is their thermal, mechanical, and electronic stability which make possible the use of a radiofrequency bridge circuit and conventional oscillator, instead of a marginal (regenerative) oscillator with its attendant overloading tendencies. Thus, no problem has been encountered in observing the nuclear resonance in ionic melts of high conductance, while Rowland and Bromberg reported that saturation difficulties with the marginal oscillator method caused the resonance of  $Tl^{205}$  to largely disappear in the molten state of thallium salts<sup>(1)</sup>.

#### REFERENCES

1. T. J. Rowland and J. P. Bromberg, J. Chem. Phys., 29, 626 (1958).
2. S. Hafner and N. H. Nachtrieb. To be published.
3. H. L. Anderson, Phys. Rev. 76, 1460 (1949).
4. D. Georghiu and A. Valeriu, Nuclear Instruments and Methods, 16, 313 (1962).

#### ACKNOWLEDGEMENTS

The support of this work by the Air Force Office of Scientific Research through its Contract No. AF-AFOSR-49(638)-1076 with The University of Chicago is gratefully acknowledged. We wish also to thank the Advanced Research Projects Agency for the use of the Varian Associates Spectrometer and the Atomic Energy Commission for its general support to The Institute for the Study of Metals.

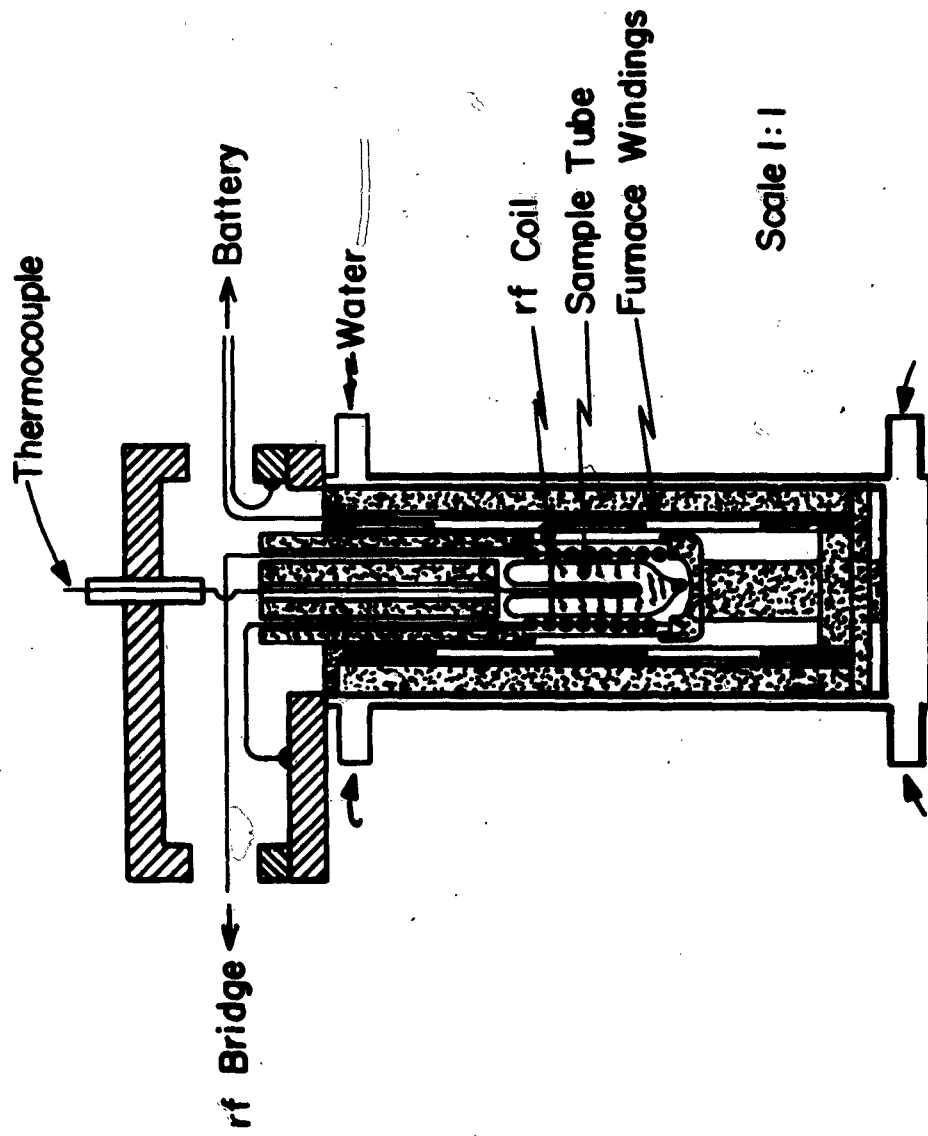

Fig.1 Probe and Furnace Design (1)

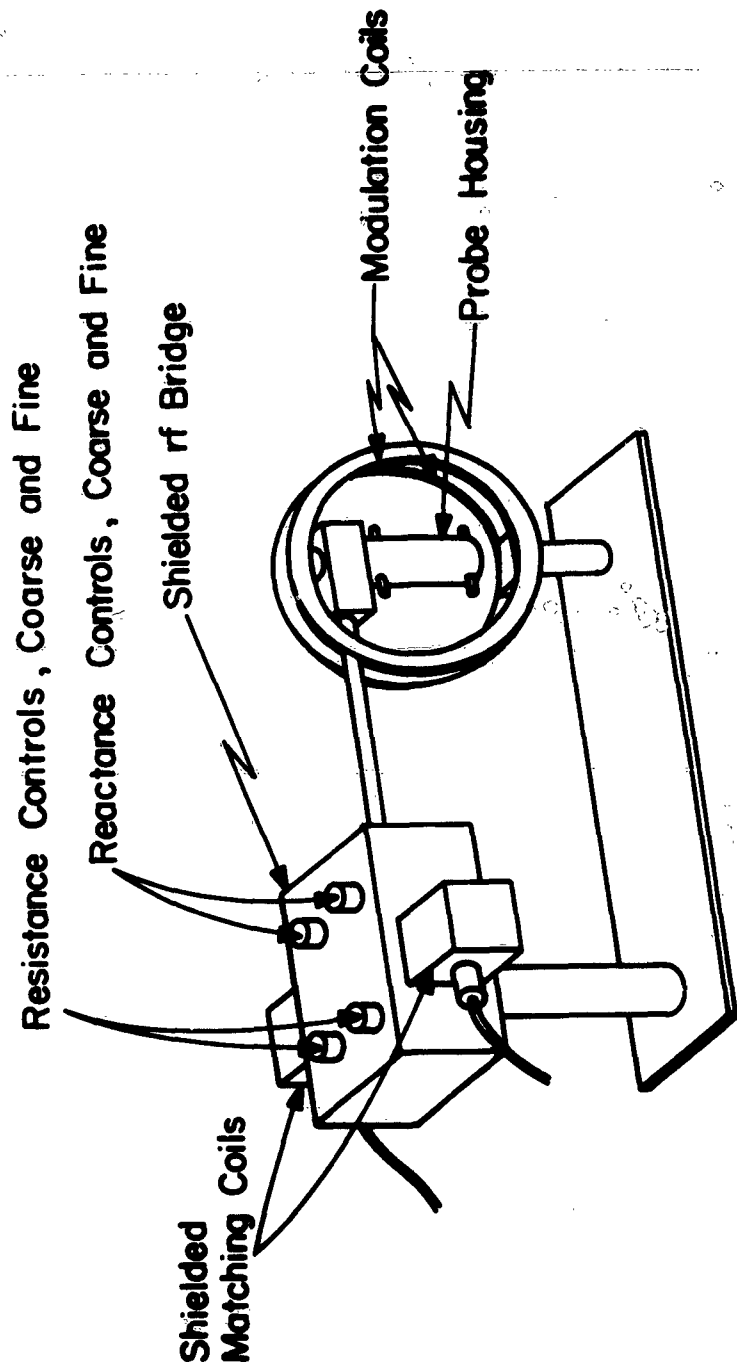

Fig. 2 Mounting for RF Bridge, Probe, and Modulation Coils

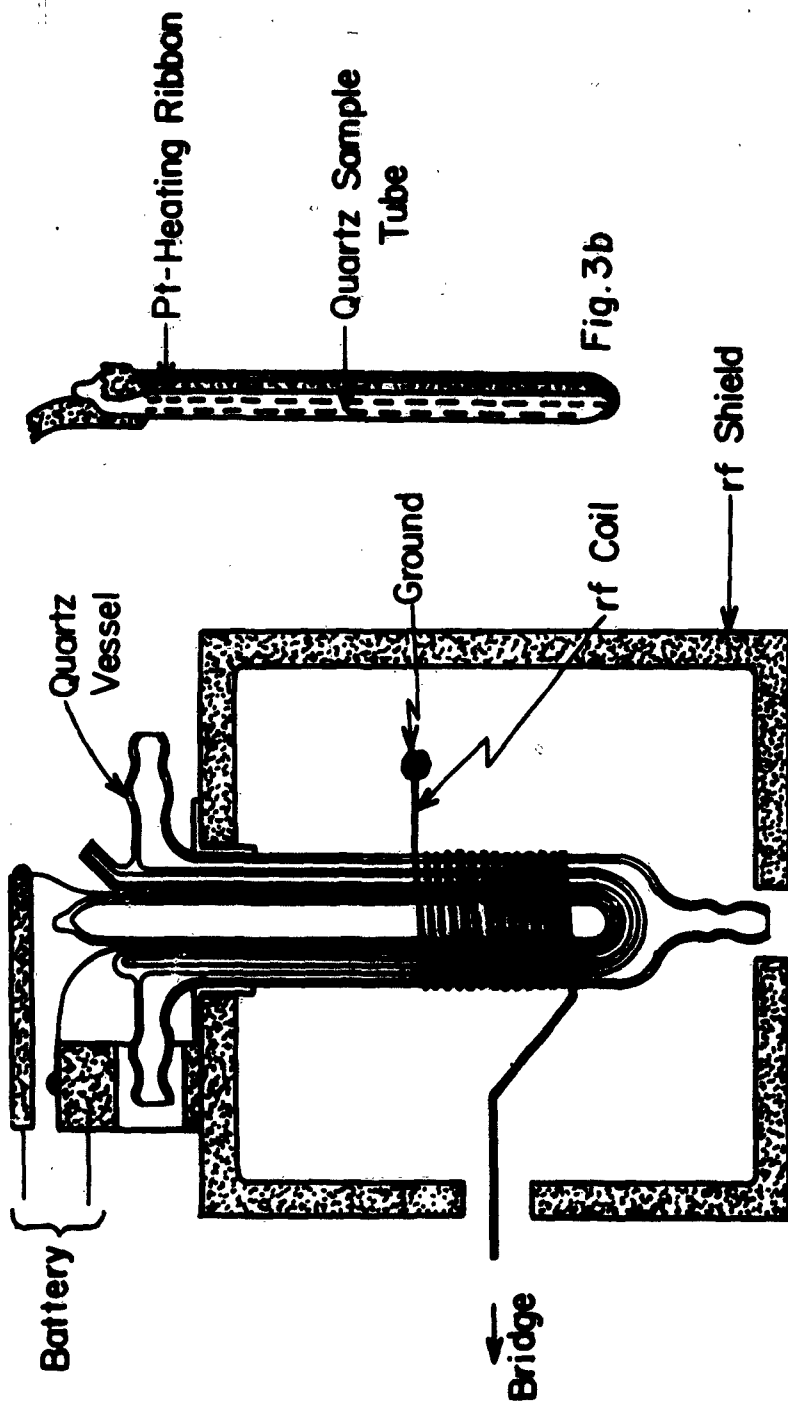
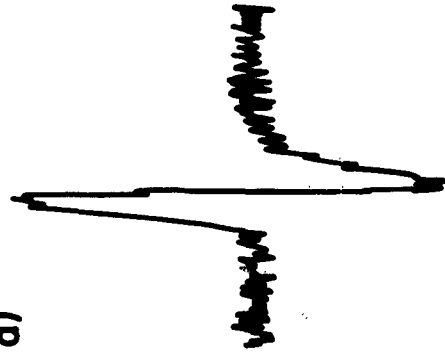

Fig. 3a. Probe and Furnace Design (2)

a)



b)



Tl<sup>205</sup> in Tl<sub>2</sub>SO<sub>4</sub>

Slow Scan @ 700°C

Na<sup>23</sup> in NaCl

Rapid Scan at 950-1000°C

Fig. 4 Derivative Absorption Signals of Tl<sup>205</sup> and Na<sup>23</sup> Resonances

**NUCLEAR MAGNETIC RESONANCE IN MOLTEN SALTS**

**I. CHEMICAL SHIFT OF CRYSTALLINE AND  
MOLTEN THALLIUM SALTS**

Stefan Hafner and Norman H. Nachtrieb

Institute for the Study of Metals

The University of Chicago

**ABSTRACT**

Relatively large chemical shifts in the resonance frequency of the thallium nucleus are observed in both the crystalline and molten states of different thallium salts. Relative to  $TlNO_3$ , which appears to be the most ionic of all thallium salts studied, the chemical shift increases in the order:  $Cl < Br < I$ . The results are interpreted in terms of a second-order paramagnetic contribution to the field at the Tl nucleus, arising from an admixture of its excited states with the ground state, and the chemical shift is approximately proportional to the square of the overlap integral. Although cations and anions in the melts are partly associated, the NMR shifts of the Tl nucleus show that the cause arises from incipient covalency rather than polarization of the cation by the halide ions.

In both the crystalline and molten states, a linear increase in the chemical shift with temperature is observed, which is attributed to the enhanced overlap of excited states which are induced by thermal vibrations.

## INTRODUCTION

It is to be expected that chemical shifts in nuclear magnetic resonance should provide information on the structure of molten salts and on the nature of the interactions between the constituent species. Although numerous studies have been reported on the NMR of crystalline salts, very little information has been published on molten salts.<sup>1)</sup> Since environmental effects on nuclear magnetic resonance arise mainly from short range interactions, it might be expected that no qualitatively different phenomena should accompany the transition from the crystalline to the liquid state unless drastic structural changes take place. For this reason, the present study of nuclear magnetic resonance in molten salts begins with the corresponding crystalline salts and takes advantage of the simplification which the symmetry properties of the latter provide. The highly symmetrical structure of most of the thallos halides, nitrate, and perchlorate, combined with the favorable nuclear properties of  $Tl^{205}$  (large magnetic dipole moment and absence of higher multipoles<sup>2)</sup>), are

---

<sup>2)</sup> Studies in progress on the resonance of  $Na^{23}$  ( $I = 3/2$ ) in molten salts show the feasibility of studies on nuclei having quadrupole moments.

---

the principal reasons for the choice of these salts for study.

When an atom is closely surrounded by other atoms, the magnetic resonance line of its nucleus shows a small but significant "chemical shift" ( $\sigma$ ) relative to the (hypothetical) resonance line of the atom in free space. The chemical shift is usually defined as  $-(\nu_S - \nu_R)/\nu_R$  at fixed magnetic field,  $H$ , or  $(H_S - H_R)/H_R$  at fixed frequency,  $\nu$ . The subscripts, S and R, refer to the nucleus in the system under study and in a fixed reference system, respectively. Ideally, the reference system for the

present study should consist of free ions, but since the magnetogyric ratio ( $\gamma = \frac{2\pi\nu}{H}$ ) is experimentally unknown for  $Tl^+$ , an arbitrary choice of the reference state must be made. The best approximation to the ideal reference would be a thallos salt which is as "ionic" as possible. The chemical shift of the thallos nucleus in other, less ionic, compounds of thallium should then be toward higher frequencies at fixed external field. Relative to the reference, the chemical shift is then primarily a measure of the magnetic interaction of the applied field with excited paramagnetic states that are mixed into the ground state of the free ion by its electrostatic interaction with neighboring ions.

Ramsey's fundamental theory<sup>(3)</sup> of the chemical shift underlies three simplified treatments for ionic compounds, all of which lead to an expression of the form:

$$(1) \quad \sigma = -\frac{16}{3} \mu_B^2 \cdot \left\langle \frac{1}{r^3} \right\rangle \frac{B}{\Delta E}$$

Yosida and Moriya<sup>(4)</sup> used a simplified Heitler-London model to account for the chemical shift in ionic crystals in terms of a covalent contribution to the metal-halogen bond. In their notation B equals  $\frac{1}{2} Z \frac{1 - \alpha^2}{\sqrt{1 - \alpha^2}} \lambda$ , where Z is the coordination number of the ion in question, and  $\sqrt{1 - \alpha^2}$  is the fraction of p character in metal ions (equal to unity for halogen ions).  $\lambda$  represents the degree of covalency, and  $\Delta E$  is the difference in energy between the ionic ground state and the non-bonding covalent state, one electron being transferred from an anion to one of the nearest cations.

Kondo and Yamashita<sup>(5)</sup> attribute the chemical shift of an ion in alkali halide crystals to overlap effects, neglecting covalency and charge transfer. B then equals  $Z\Lambda$ , where  $\Lambda$  is the sum of all overlap integrals between the outermost p orbitals of the cation which point toward a nearest anion and all the orbitals of that anion.  $\Delta E$  is an average over the energies of the excited states of the ion in the crystal, and is approximated by Kondo and Yamashita

as the energy separation of the first excited singlet state of the free cation.

Griffith and Orgel<sup>(6)</sup>, dealing with the chemical shifts of transition metal ions in complexes, pointed out that  $B/\Delta E$  should increase with the decreasing field strength produced by the ligands, and experimental data on  $\text{Co}^{+3}$  complexes are consistent with their analysis. For cations with two unshared s electrons B is identified with the p fraction,  $\sqrt{1 - \alpha^2}$ , of the hybrid (decreasing with increasing ligand field strength). As in the Kondo-Yamashita model,  $\Delta E$  is the energy separation of the first excited singlet state of the free ion above the ground state.

Although each of these approaches the problem of approximating the terms in the Ramsey equation from a different standpoint, they have in common the interpretation that the chemical shift arises from low-lying excited paramagnetic states. This is also the conclusion drawn from the present work.

#### EXPERIMENTAL

Some of the thallium salts used in this study were obtained commercially and others were prepared by standard methods from thallium metal. All were found to be free of paramagnetic impurities to the limit of spectrographic detection. Lead and zinc were the chief impurities, present to the extent of 0.001 - 0.1%, and are believed to be without influence on the measurements.  $\text{Tl}^{205}$  resonance frequencies were observed at about 14 mc/sec. (approximately 5800 Gauss) with a Varian 4200B wide line spectrometer. Instead of the conventional Varian probe with two crossed coils, a single coil was used in conjunction with an Anderson-type<sup>(7)</sup> parallel twin bridge. The choice of the single coil method gave greater flexibility in the design of the sample furnace for high temperature studies. Two possibilities for furnace construction were tested: (i) heating and cooling elements inside of the resonance coil, which is maintained at room temperature, and (ii) a heating element outside of the sample tube and resonance coil, with an outer cooling jacket. Both were successful, although (ii) is

limited to temperatures below the melting point of the silver wire used for the resonance coil. Since thallium salts have relatively low melting points, most of the experiments were carried out with the simpler construction (ii).

A second circuit was built with a small reference coil, which was kept at room temperature. Since a proton sample was chosen as the working reference a conventional marginal oscillator was adequate. The reference coil was 4 cm. distant from the center of the sample coil, and the frequency and magnetic field impressed on the heated sample at a fixed temperature could be determined within some seconds by simply moving the coils over that distance. Separate intercalibrated frequency counters were used in the sample and reference circuits. The absorption mode of the  $Tl^{205}$  resonance was observed throughout, and it was possible to work with lines of intrinsic width by use of low modulation fields and low rf power. Signals were displayed on an oscilloscope. The use of a recorder-amplifier was not generally necessary.

#### RESULTS AND DISCUSSION

Figure 1 summarizes the measurements made of the resonance frequency of  $Tl^{205}$  in a variety of crystalline and molten salts as a function of temperature. The ordinate scale at the left gives the ratio  $\omega_{Tl} / \omega_H$ , with pure water as the proton reference. The scale at the right provides the chemical shift at fixed external magnetic field. Its zero is somewhat arbitrary, since the true magnetogyric ratio of the free thallos ion is not known. Under the circumstances, the best approximation to the free ion value would seem to be the provisional selection of the lowest resonance frequency observed in any thallium compound. It is not surprising that crystalline  $TlNO_3$  and  $Tl_2SO_4$  are among the salts which have the smallest values of  $\omega/H$ . The lowest value yet observed is for the molten composition  $TlClO_4 \cdot AgNO_3$ .  $TlClO_4$  itself is unstable in the

liquid state, and the  $Tl^{205}$  resonance could not be detected in the crystalline state. It seems unlikely that thallium salts exist which have significantly lower magnetogyric ratios in either the molten or solid states, and the dotted line of Figure 1 is our best "guess" for the intrinsic zero. The comparison of the  $Tl^{205}$  shifts among various salts is unaffected by the choice of base line, of course, but a reasonable assignment is needed if the Ramsey model is to be used for calculations. Other approximations to the free ion value, based upon extrapolations to infinite dilution of measurements of aqueous solutions of thallos salts, have far less validity, as Gutowsky and McGarvey point out.<sup>(8)</sup> Figure 2 shows the remarkably higher magnetogyric ratio we have observed for aqueous  $Tl^+$ , as compared with that of crystalline  $TlNO_3$  or an equimolar molten solution of  $TlClO_4$  with  $AgNO_3$ .

To the objection that  $Tl^+$  is not very "ionic" even in crystals such as  $TlNO_3$  or  $TlClO_4$ , several arguments may be offered: These salts have cubic symmetry in the crystalline state, and the comparatively large number (8) of equivalent nearest neighbor anions having large radii should cause a minimum of cation polarization. On chemical grounds, thallos salts have properties (e. g., aqueous solubilities) which place them between the alkali halides and the silver halides in ionic character.

#### CHEMICAL SHIFTS IN CUBIC THALLOUS SALTS

The thallium chemical shifts in both crystalline and molten thallium salts show a remarkable progression in the order:  $I^- > Br^- > Cl^- > NO_3^-$ . This sequence is consistent with the observations of Griffith and Orgel<sup>(6)</sup>, who find in  $Co^{+3}$  complexes that the paramagnetic shielding effects are large for ligands which produce small electric fields. Thallos fluoride occupies a position between  $TlBr$  and  $TlCl$ , indicating that the electron affinity<sup>(9)</sup> of the halogen atom rather than its electronegativity is the important factor. For solid  $TlF$   $\sigma$  is about  $-16 \times 10^{-4}$ ; its peculiar crystal

structure is probably responsible for the broad resonance observed. It is a low symmetry form, which may be regarded as a distortion of the NaCl structure.  $\sigma$  is therefore anisotropic, and the observed value in the polycrystalline powder is an average over its tensor components.

For a discussion of the B term in the Ramsey equation it is convenient to begin with the crystalline halides which have cubic symmetry and to evaluate it from measured values of  $\sigma$  and approximations to the quantities,  $\Delta E$  and  $\langle \frac{1}{r^3} \rangle$ . Several approximations to  $\Delta E$  can be made. Yosida and Moriya assumed electron transfer from anion to cation, and used the von Hippel equation<sup>(10)</sup> to estimate the lowest excited anion state thereby:

$$(2) \quad \Delta E_a = \frac{(2\beta - 1)e^2}{d} + E - I + Q$$

In this equation  $\beta$  is the Madelung constant,  $E$  is the halogen electron affinity,  $I$  is the ionization potential of the metal atom, and  $Q$  is the polarization interaction between the free atoms which results from charge transfer;  $e$  and  $d$  are the electronic charge and nearest cation-anion distance, respectively. Yosida and Moriya were interested primarily in the chemical shifts of anion nuclei, but stated that  $\Delta E_c$  should not be very different from  $\Delta E_a$ .

A second approach to  $\Delta E$  can be made by identifying it with the ultraviolet absorption bands of  $Tl^+$  in ionic crystals. Seitz<sup>(11)</sup> analyzed the spectroscopic data of Hilsch and Pohl<sup>(12)</sup> and others for alkali halide crystals containing small concentrations of  $Tl^+$ . He concluded that charge transfer from the host anions to  $Tl^+$  would not account for the bands, whose absorption shifts only slightly when one anion host lattice is substituted for another. He attributed the Tl bands to transitions from the ground state to the excited 6s6p states of the cation, and argued that the fundamental charge transfer band must lie at rather higher energy. We make the assumption that  $\Delta E_c$  of the pure thallos halide is about the same as for  $Tl^+$  ion in the alkali halides analyzed by Seitz. The values of  $\Delta E_c$  in Table 1 (col. 3)

correspond to the mean of the three bands associated with transitions from the ground state to the excited  $6s6p$  states of the  $Tl^+$  ion. They agree with the early experimental data of Fesefeldt<sup>(12, 13)</sup>, but are remarkably lower than the  $\Delta E$  values calculated from Equation 2 (neglecting  $Q$ ), which can only be regarded as providing an upper limit. Kondo and Yamashita<sup>(5)</sup> take the value of  $\Delta E_c$  to be the 1st excited state of the free cation. This will be lowered in the crystalline state, however, and we assume that the spectroscopic results cited by Seitz provide a more nearly correct estimate.

For  $\langle \frac{1}{r^3} \rangle$  both Yosida and Moriya and Kondo and Yamashita choose the value for the free ion. Baron<sup>(14)</sup> selected  $\langle \frac{1}{r^3} \rangle$  of the free atom for his application of the Yosida-Moriya<sup>(4)</sup> model as a consequence of charge transfer. However, it is to be expected that the Tl atom wave function should be more localized in the crystal by virtue of the negative charge on the nearest neighbor anions. For this reason a value intermediate between  $\langle \frac{1}{r^3} \rangle_{Tl^+}$  and  $\langle \frac{1}{r^3} \rangle_{Tl}$  would probably be more nearly correct; fortunately the difference is less marked for heavy atoms than it is for light atoms.  $\langle \frac{1}{r^3} \rangle_{Tl}$  ( $= 11.8 \text{ a.u.}^{-3}$ ) was taken from Barnes and Smith<sup>(15)</sup> (without relativistic correction), and  $\langle \frac{1}{r^3} \rangle_{Tl^+}$  ( $= 18.8 \text{ a.u.}^{-3}$ ) was calculated from the  $6p^3 P_0$  splitting in the same way. Table 2 uses the  $18.8 \text{ a.u.}^{-3}$  value.

For the evaluation of the factor  $\sqrt{1 - \alpha^2}$  Yosida and Moriya assumed a tetrahedral  $sp^3$  metal hybrid for the bonding ground state. However, because this violates the point symmetry of the cation lattice sites, we prefer to assume a pure  $6p$  state for  $Tl^+$ , with its orbital axis in the direction of one of the nearest anions. The factor  $\sqrt{1 - \alpha^2}$  then becomes unity, as Kondo and Yamashita assume, and the difference from Yosida and Moriya's value is numerically small.

Under these circumstances,  $B$  becomes numerically almost identical for both the charge transfer and excited cation approximations, suggesting that covalency and overlap effects are different aspects of the same bonding situation. The degree of covalency  $\lambda$ , and overlap  $A$ , respectively, of

the thallium halides calculated from the NMR data of Figure 1 and Table 1 (col. 4) are listed in Table 2. Their validity as a covalent bonding parameter is difficult to assess, however, despite the excellent agreement between our values derived from cation-NMR results and those calculated by Yosida and Meriya from Kanda's anion-NMR data<sup>(16)</sup> for the same salts. Here the choice of the zero shift reference enters even though the two studies are quite independent.

#### CHEMICAL SHIFTS IN NON-CUBIC THALLOUS AND THALLIC SALTS

The interpretation of the chemical shift in  $Tl_2SO_4$  is difficult. Its  $Tl^+$  ions occupy two non-equivalent lattice sites with low point symmetry, and hence two  $\sigma$  tensors exist. Moreover, the lack of a center of symmetry about the  $Tl^+$  sites leads to cation polarization and therefore to induced excited states. This contribution to  $\sigma$  may be quite significant because of the high polarizability ( $\sim 5 \text{ \AA}^3$ )<sup>(17)</sup> of the  $Tl^+$  ion. These rather complex circumstances preclude a more detailed discussion. Nevertheless,  $Tl_2SO_4$  is isomorphous with  $K_2SO_4$ , and the location of its  $Tl^{205}$  resonance on Figure 1 shows it to be a predominately ionic salt.

TlI is orthorhombic below  $175^\circ\text{C}$  with fewer than the eight nearest neighbors of the CsCl structure, while  $TlCl$  and  $TlBr$  are cubic at all temperatures below their melting points. The relatively large degree of covalency in TlI is evidenced by its large  $\sigma$ .

The non-cubic symmetry of  $TlNO_3$  below  $144^\circ\text{C}$  results from the peculiarities of the nitrate ion (planar trigonal structure) rather than from covalent bonding. The transition which is visible in the chemical shift at this temperature is believed to be due to disorder in the  $NO_3^-$  sub-lattice.

Two thallic salts are depicted in Figure 1:  $TlCl_3$  and  $Tl(ClO_4)_3$ . Both show large chemical shifts, which arise from two causes: (i) diminished diamagnetism of the ion core, resulting from the loss of both  $6s$  electrons and (ii) the covalent character of the bonds to neighboring anions. It is

for the latter reason that the metal atom sites of all thallic compounds possess low symmetry and low coordination number. Such compounds deviate so markedly from idealized ionic salts that an approximation of B by either the Yosida-Moriya or Kondo-Yamashita models is not justified. The detailed crystal structures of both  $TlCl_3$  and  $Tl(ClO_4)_3$  are still unknown, so that an estimate of the bond strength ( $\sqrt{1 - \alpha^2}$ ) of the Tl 6sp hybrid, as suggested by Orgel<sup>(18)</sup>, is not yet possible.

#### NMR IN THE MOLTEN STATE

Although those properties of molten salts which depend upon long range interactions of particles cannot be related in any simple manner to the crystalline state, there are no difficulties in principle in the application of Equation 1 to ionic melts. This comes about because NMR chemical shifts, as well as relaxation effects, are largely determined by the local symmetry of the nuclear sites; i. e. the symmetry within a sphere drawn about the nucleus with a radius comparable to the lattice constant. In an ideal ionic crystal the local symmetry of each ion is identical with the point symmetry of the ion site, and the main difference between crystal and melt arises from the loss of translational order. It is often assumed that the local symmetry in ionic salts is largely preserved on fusion, and although there may be changes in the local configuration a relatively high degree of local order is believed to remain in molten salts. The quite stringent requirement of "strong electroneutrality" greatly aids in maintaining a form of local order, since it requires that the immediate neighbors of a given ion generally consist of ions of opposite sign. Strong local electroneutrality may be relaxed if the departure from a predominately ionic melt is appreciable.

In fact, the chemical shifts and line widths of solid and molten thallium salts are not greatly different (Table 3). The line widths of the three thallic halides range from 0.1 to 0.7 KC. Except for  $Tl(ClO_4)_3$ ,

the shift is invariably in the paramagnetic direction on fusion, and the magnitude of the shift is less than the difference between that of the melt and that of an aqueous thallos solution. Roughly speaking, the chemical shift on fusion for a given thallos halide is comparable to the difference from one halide to another in the series: Cl, Br, I, in either the solid or molten state. For the foregoing reasons it appears that all the terms of Equation 1 remain more or less meaningful for molten salts, although they must undergo some numerical changes.

In Table 1 (Col. 5) values of  $\sigma$  for several molten salts have been extrapolated to a common temperature (500°C), based on the data of Figure 1. For the molten thallos salts  $\sigma_{500}$  is markedly higher than for the corresponding solids at 20°C. Unfortunately, almost no absorption spectroscopic measurements for molten salts exist which would permit an estimation of  $\Delta E_c$  and a corresponding calculation of  $\Lambda$ . That  $\Delta E_c$  undergoes a decrease in the molten state is qualitatively certain, however. Retschinsky<sup>(19)</sup> observed a red shift with increasing temperature for the edges of the fundamental absorption bands of KCl, KBr, and KNO<sub>3</sub> and an abrupt decrease at their melting points. Rhodes and Ubbelohde<sup>(20)</sup> found a red shift of 0.7 eV (~12%) in the charge transfer band maximum of LiI between 20°C. and the melt at 451°C. The corresponding bands of LiNO<sub>3</sub>, NaNO<sub>3</sub>, KNO<sub>3</sub>, and AgNO<sub>3</sub> also shifted from 0.1 to 0.5 eV (2 - 10%) between 20° and the melts (214 - 340°C). Moreover, the 1st excited states of the gaseous thallos halides are 4.4 eV (TlF), 3.8 eV (TlCl), 3.6 eV (TlBr), and 3.3 eV (TlI). These provide lower limits for the corresponding 1st excited states in the molten salts, and therefore maximum possible values for the shift in  $\sigma$  on fusion. Although it is clear that  $\Delta E_c$  decreases on fusion and a part of the chemical shift must be attributed to this decrease, it is equally clear that this does not account for all of the increase in  $\sigma$ . B must clearly increase.

The number of nearest neighbors, Z, can be estimated either from the radial distribution functions of the molten alkali chlorides as determined

by X-ray diffraction<sup>(21)</sup> or by use of the packing density arguments<sup>(22)</sup>. For the alkali halide melts  $Z$  has been estimated to decrease from 8 to about 4.5. Thus, the degree of covalency  $\lambda$ , or the mean anion-cation overlap  $\Lambda$ , should increase in the molten state by about a factor of two, as compared with the corresponding solid in order to satisfy the observed  $\sigma$ 's.

Other evidence related to the increase in  $\Lambda$  (overlap) in molten salts is provided by Table 4, which lists cation-anion distances in the crystalline, molten, and gaseous states. Stillinger<sup>(23)</sup> calculated distance of closest approach for oppositely charged ions, based on the Reiss-Frisch-Lebowitz<sup>(24)</sup> rigid sphere model. His values at 700°C. are about 10% lower than the corresponding interionic distances in the crystal at 20°C. Levy's experimental values for the mean interionic distance<sup>(21)</sup> show a similar, though less pronounced, trend. In the gaseous thallium halides the "cation-anion" distance is about 20% lower than in the crystal. Quite evidently, the interionic distances in molten salts lie intermediate between those in the crystalline and gaseous states.

Further support for the conclusion that overlap effects are largely responsible for the chemical shift on fusion may be found in Löwdin's cohesive energy calculations<sup>(25)</sup> for alkali halide crystals. His calculations show that a 10% decrease in the cation-anion distance leads to a 2 - 2.5 fold increase in the square of the overlap integrals.

The question of whether the shortened cation-anion distance should be regarded as "ion-pairing" or "partial covalency" is not a mere semantic one. For while the X-ray evidence shows that cation-anion distances are diminished in molten salts, and mobility measurements show that diffusion<sup>(26)</sup> is larger than electrolytic mobility<sup>(27)</sup>, neither observation accounts for the cause of the apparent association.

Bockris and coworkers<sup>(28)</sup>, following the coupled vacancy model proposed by Seitz<sup>(29)</sup> and Dienes<sup>(30)</sup> for diffusion in ionic solids, account for the discrepancy between the measured and calculated (Nernst-Einstein)

diffusion coefficients of molten salts on the assumption that diffusion of ions without charge transport may occur by consecutive jumps of associated cation and anion vacancies.

Klemm<sup>(31)</sup>, on the other hand, has suggested that cation-anion complexes in molten  $TlCl$  become more abundant with increasing temperature and thereby accounts not merely for the apparent failure of the Nernst-Einstein relation but also for the linear decrease with temperature of the  $Tl^{203}$  isotope mass separation factor. This is completely in accord with our interpretation that covalency increases with temperature. The NMR shifts show that excited paramagnetic states are mixed into the bonding of anions and cations, and are relatively more important in molten salts than in the crystalline state. An even more cogent argument shows that "ion-pairing" resulting from polarization is not consistent with the NMR data. For if this were the case, polarization of the cation and deshielding of its nucleus by an anion should vary in the order  $Cl > Br > I$ ; just the reverse is observed in the  $Tl^{205}$  NMR shifts.

The trivalent thallium salts deserve special comment. Unlike the thallos halides, nitrate, and sulfate, they show a very small chemical shift on fusion, and  $Tl(ClO_4)_3$  moves in the diamagnetic direction. These are not predominately ionic melts, however, as is evidenced by the fact that their specific conductance in the molten state is smaller by a factor of  $10^5$  than that of the thallos salts. In the solid state they form molecular crystals, whose low symmetry for the  $Tl^{III}$  sites is governed by molecular forces and steric considerations, rather than by the isotropic coulombic interactions of ions. On fusion the local symmetry of the  $Tl^{III}$  atoms is little changed. Here the dictum of strong electroneutrality is satisfied within each molecule, rather than statistically in the 1st coordination sphere of a given ion. Presumably, the very large chemical shift of  $TlCl_3$  relative to  $TlNO_3$  and its very small change on melting mean that nuclei of the  $Tl^{III}$  atoms are deshielded within the molecule, but are quite effectively shielded from neighboring molecules by their own three chlorine atoms.

Even in the gaseous state it seems likely that the magnetogyric ratio of  $Tl^{III}$  in  $TlCl_3$  will differ little from its value in the molten state.

#### TEMPERATURE-DEPENDENCE OF THE CHEMICAL SHIFT

The question of why covalent bonding, rather than ion-pairing due either to coulomb or polarization forces, is indicated by the NMR chemical shifts is bound up with the observation of the temperature-dependence. The association of ions which are attracted by coulomb forces alone can only decrease with increasing thermal energy. However, the shifts observed are in the paramagnetic direction and seem to increase linearly with temperature in both the solid and liquid states. We must conclude that cations and anions do associate, with a positive temperature coefficient, but that the forces responsible for the attraction are neither coulombic nor polarization in origin. That increasing covalency with increasing temperature is a quite general phenomenon may readily be seen.

First, however, it must be shown that the observed temperature coefficient ( $d\sigma/dT \approx 10^{-6} \text{ deg}^{-1}$ ) is not to be explained in a trivial way as the increase in magnetic induction with increasing thermal expansion of the salt. We may write:

(3)  $\frac{dB}{dT} = 4\pi \chi \cdot H \cdot \frac{d\rho}{dT}$ , where B is the magnetic induction,  $\chi$  is the specific magnetic susceptibility, and  $\rho$  is the salt density. Taking for  $TlCl$  the values,  $\chi = -0.19 \times 10^{-6}$ ,  $d\rho/dT = -1.8 \times 10^{-3} \text{ gm cm}^{-3} \text{ deg}^{-1}$ , we obtain  $dB/dT = 0.26 \times 10^{-4} \text{ gauss deg}^{-1}$  at 6,000 gauss. The contribution to  $d\sigma/dT$  is then  $\frac{1}{H} \cdot \frac{dB}{dT} = 4.3 \times 10^{-9} \text{ deg}^{-1}$ , which is wholly negligible (Cf. Table 1).

A more significant contribution to the shift comes from the dependence of  $\Delta E$  on temperature. Fesefeldt<sup>(32)</sup>, in a very careful early study of thin films of potassium iodide and rubidium bromide, found the red shift of the fundamental absorption band to be  $0.93 \times 10^{-3} \text{ eV deg}^{-1}$  and  $0.74 \times 10^{-3} \text{ eV deg}^{-1}$ , respectively (linear from  $-253^\circ\text{C.}$  to  $220^\circ\text{C.}$ ). Martienssen<sup>(33)</sup>

has observed a similar red shift ( $0.7 \times 10^{-3} \text{ eV deg}^{-1}$ ) for solid potassium bromide. No perceptible shift was observed by Fesefeldt<sup>(13)</sup> between  $-186^\circ\text{C}$  and  $20^\circ\text{C}$ . for  $\text{TlCl}$ ,  $\text{TlBr}$ , or  $\text{TlI}$ , however. We are led to the conclusion that although  $\Delta E$  may decrease linearly with temperature, its contribution to the NMR shift is still minor.

The major part of the linear temperature dependence of the NMR shift must therefore arise from the vibrational overlap of the cation-anion wave functions. The effective vibrations are those infrared modes that remove the center of symmetry from the Tl site; those modes (acoustic) which preserve the point symmetry do not influence the mean overlap of nearest neighbors. The infrared absorption maximum in  $\text{TlCl}$  which appears at  $50 \mu$  can be regarded as a standing wave, in which the Tl sublattice vibrates as a whole in the  $\langle 111 \rangle$  direction against the halide sublattice. At the temperatures of the NMR experiments such vibrational states are well-populated.

From Equation (1) we may write:

$$(4) \quad \frac{1}{\sigma_0} \cdot \frac{d\sigma}{dT} = \frac{1}{\Lambda_0} \cdot \frac{d\Lambda}{dT}$$

Moreover, to first order the temperature-dependence of  $\Lambda$  may be taken as

$$(5) \quad \Lambda = \Lambda_0 + \frac{\partial^2 \Lambda}{\partial x^2} \cdot \overline{u_x^2} ; \quad \frac{\partial \Lambda}{\partial T} = \frac{1}{3} \frac{\partial^2 \Lambda}{\partial x^2} \cdot \frac{\partial (\overline{u_x^2})}{\partial T}$$

where  $\Lambda$  is the sum over the squares of all overlap integrals, and  $\overline{u_x^2}$  is the mean square amplitude of vibration along the line of centers of an anion and a cation, and  $\overline{u_x^2} = 1/3 \overline{u^2}$ . Several ways of approximating  $\frac{d\overline{u_x^2}}{dT}$  might be chosen. For temperatures above  $\theta_D$ , Leibfried has shown<sup>(34)</sup> that

$$(6) \quad \overline{u^2} = \frac{18}{M\omega_D^2} \cdot kT, \text{ and hence}$$

$$(7) \quad \frac{\partial \overline{u^2}}{\partial T} = \frac{18k}{M\omega_D^2} = 18 \frac{h^2}{Mk\theta_D^2}$$

Table 5 (Column 3) lists the values of the mean-squared thermal amplitude coefficient, calculated from Equation 7 with  $\theta_D = 126^\circ\text{K}$  and  $113^\circ\text{K}$

for TlCl and TlBr, respectively, using the elastic constants<sup>(35)</sup> of these salts. James' and Brindley's measurements of the thermal broadening of the X-ray reflections of KCl<sup>(36)</sup> lead to a value of about  $2 \times 10^{-20}$  for the thermal coefficient of the mean-squared amplitude, and indicate that our approximation for the thallos salts is of the correct order of magnitude.

The dependence of the square of the overlap integral upon the mean-squared vibrational amplitude is much more difficult to estimate. A reasonable estimate can be made, however, for salts which are predominately ionic, since the radial part of the ion wave functions falls off exponentially with distance. Löwdin's calculations<sup>(25)</sup> of the overlap integrals as a function of interionic separation for a variety of s and p orbitals of the anion and cation in NaCl and LiCl are tabulated. They show that the fractional change in the square of the overlap with respect to the interionic separation in the vicinity of the equilibrium distance is about the same, independent of the particular cation and anion orbitals. This arises, of course, because NaCl and LiCl are predominately ionic, and only the outermost exponential portions of any of the orbitals are involved in the overlap. We make the assumption that this is also approximately true for TlCl and TlBr, and take the fractional change in the square of the overlap with amplitude squared to be the same as for those alkali halides. This leads to a value for  $\frac{1}{\Lambda_0} \cdot \frac{d^2 \Lambda}{dx^2} = 1.3 \times 10^{17} \text{ cm}^{-2}$ , averaged over the overlaps of both the s and p orbitals of the thallos and halide ions. This value is certainly correct to order of magnitude, and is probably valid to within a factor of two.

Table 5 shows the comparison of the observed fractional chemical shift with temperature with the estimates obtained through the use of Equations 4 and 5 and the approximations indicated above. The agreement in the case of TlCl is certainly fortuitous, and even the order of magnitude agreement in the case of TlBr suggests that the cause of the linear temperature dependence of the chemical shift is the increase in the mixing of excited states as a result of vibrational overlap.

Although the discrepancy between the observed temperature-dependence for TlBr and the estimated value differs by an amount which is within the probable reliability of the approximations, it may be significant that the discrepancy is even larger for TlI. The chemical shift for TlI places this compound rather close to the thallic salts, which exhibit virtually no temperature-dependence and which are considerably more covalent than the thallic salts. The trend through TlCl, TlBr, and TlI may mean that the overlap becomes so large that the approximations which start from an ionic model are no longer valid. At the other extreme, the very large temperature dependence of the chemical shift of solid thallic acetate would appear to mean that the degree of configuration mixing increases with anomalous rapidity. Both of these questions require further study, and will be the subject of a future communication.

#### ACKNOWLEDGEMENTS

The partial support of this research by the Air Force Office of Scientific Research under Contract No. AF-49(638)-1076 is gratefully acknowledged. We wish also to thank the Atomic Energy Commission for general support of the Institute for the Study of Metals and the Advanced Research Projects Agency, through whose Contract SD-89 with the University of Chicago the Varian NMR Spectrometer was obtained.

REFERENCES

- 1) T. J. Rowland and J. P. Bromberg, J. Chem. Phys. 29, 626 (1958).
- 3) N. F. Ramsey, Phys. Rev. 78, 699 (1950).
- 4) K. Yosida and T. Moriya, J. Phys. Soc. Japan, 11, 33 (1956).
- 5) J. Kondo and J. Yamashita, J. Phys. Chem. Solids, 10, 245 (1959).
- 6) J. S. Griffith and L. E. Orgel, Trans. Faraday Soc. 53, 601 (1957).
- 7) H. L. Anderson, Phys. Rev. 76, 1460 (1949).
- 8) H. S. Gutowsky and B. R. McGarvey, J. Chem. Phys. 91, 81 (1953).
- 9) R. S. Berry and C. W. Reimann, J. Chem. Phys. 38, 1540 (1963).
- 10) See e. g. H. R. Ruffa, Phys. Rev. 130, 1412 (1963).
- 11) F. Seitz, J. Chem. Phys. 6, 150 (1938).
- 12) The references are listed completely in 11).
- 13) H. Fesefeldt, Z. Physik 64, 741 (1930).
- 14) R. Baron, J. Chem. Phys. 38, 173 (1963).
- 15) R. G. Barnes and W. V. Smith, Phys. Rev. 93, 95 (1954).
- 16) T. Kanda, J. Phys. Soc. Japan, 10, 85 (1955).
- 17) J. R. Tessman, A. H. Kahn, and W. Shockley, Phys. Rev. 92, 890 (1953).
- 18) L. E. Orgel, Mol. Phys. 1, 322 (1958).
- 19) T. Retschinsky, Ann. Physik. 27, 100 (1908).
- 20) E. Rhodes and A. R. Ubbelohde, Proc. Roy. Soc. 251A, 156 (1959).
- 21) H. A. Levy et al., Ann. N. Y. Acad. Sci. 79, 762 (1960).
- 22) K. Furukawa, Discussions of the Faraday Soc. 32, 53 (1961).
- 23) F. H. Stillinger, J. Chem. Phys. 35, 1581 (1961).
- 24) H. Reiss, H. L. Frisch, and J. L. Lebowitz, J. Chem. Phys. 31, 369 (1959).
- 25) P. O. Löwdin, Advances in Physics 5, 1 (1956).
- 26) E. R. Van Artsdalen, D. Brown, A. S. Dworkin, and F. J. Miller,  
J. A. C. S. 78, 1772 (1956).
- 27) K. Laybourn and W. Madgin, J. Chem. Soc. (London) 1, (1934).
- 28) A. Z. Borucka, J. O'M. Bockris, and J. A. Kitchener, Proc. Roy. Soc.  
Lond. A241, 554 (1957).

- 29) F. Seitz, Rev. Mod. Phys. 18, 384 (1946).
- 30) G. J. Dienes, J. Chem. Phys. 16, 620 (1948).
- 31) W. Fischer, K. Heinzinger, W. Herzog, and A. Klemm, Z. f. Naturforschung 17a, 799 (1962).
- 32) H. Fesefeldt, Z. f. Physik, 64, 623 (1930).
- 33) W. Martienssen, J. Phys. Chem. Solids 2, 257 (1957).
- 34) G. Leibfried, Handbuch der Physik VII/1.
- 35) S. Hausstühl, Acta Cryst. 13, 685 (1960).
- 36) R. W. James and G. W. Brindley, Proc. Roy. Soc. Lond. 121A, 155 (1929).

TABLE 1  
CHEMICAL SHIFTS OF SOLID AND MOLTEN THALLIUM SALTS

	Crystal Structure	Fundamental Absorption Band e. V	Crystalline State		Molten State - $\sigma \cdot 10^4$ 500°C	Slope	
			State - $\sigma \cdot 10^4$ 20°C	State		(Crystalline State) - $d\sigma/dT \cdot 10^6$ deg. $^{-1}$	(Molten State) - $d\sigma/dT \cdot 10^6$ deg. $^{-1}$
TlNO <sub>3</sub>	Cubic (NaCl) <sup>1)</sup>	(3.7) <sup>3)</sup>	1.7	~0	6.7 <sup>4)</sup>	~0	0.70±0.05
Tl <sub>2</sub> SO <sub>4</sub>	Orthorhombic		2.6	0.48±0.05	7.8 <sup>4)</sup>	0.48±0.05	0.43±0.05
TlF	Orthorhombic (deformed NaCl)				18.2 <sup>4)</sup>		0.77±0.05
TlCl	Cubic (CsCl)	5.70	6.3	0.86±0.05	16.1	0.86±0.05	0.78±0.05
TlBr	Cubic (CsCl)	5.02	11.0	0.60±0.05	19.4	0.60±0.05	0.73±0.05
TlI	Cubic (CsCl) <sup>2)</sup>	4.75	21.5	<0.2	25.6	<0.2	1.4±0.1
Tl(ClO <sub>4</sub> ) <sub>3</sub>	Unknown		22.7	~0	21.8 <sup>4)</sup>	~0	~0
TlCl <sub>3</sub>	Monoclinic		27.9	~0	28.2 <sup>4)</sup>	~0	~0
Tl acetate	Unknown		7.8	4.2±0.1	13.3 <sup>4)</sup>	4.2±0.1	0.56±0.05

1) Above 143°C.

2) Above 175°C.

3) Estimate, based on the difference (2.0 eV) between the absorption-maxima for the alkali chlorides and the corresponding nitrates. (cf. observed value of 4.4eV for AgNO<sub>3</sub>).

4) Extrapolated from Fig. 1.

TABLE 2

DEGREE OF COVALENCY (OVERLAP)  
OF CUBIC THALLOUS SALTS

Crystal	$\lambda, \Lambda$	
	From Table 1	From the anion shift (ref. 4)
TlNO <sub>3</sub>	(0.006	
TlCl	0.033	0.039
TlBr	0.051	0.047
TlI	0.095	

TABLE 3

CHEMICAL SHIFT ON FUSION

	$-\Delta\sigma \cdot 10^4$	$-\Delta\sigma \times 10^4$ Rowland & Bromberg <sup>(1)</sup>
TlNO <sub>3</sub>	1.7	1.3
Tl <sub>2</sub> SO <sub>4</sub>	2.6	
TlCl	5.6	6.0
TlBr	5.6	5.6
TlI	3.1	
Tl(ClO <sub>4</sub> ) <sub>3</sub>	-0.8	
TlCl <sub>3</sub>	0.02	
Tl acetate	<±0.02	

TABLE 4

INTERIONIC DISTANCES IN SOLID, MOLTEN,  
AND GASEOUS SALTS (cm x 10<sup>8</sup>)

Salt	Crystal Room Temp.	Closest Approach		Mean Melt 3)	Gas
		Melt, 700°C 2)	Melt 3)		
CsCl	3.56	3.01	3.03	3.53	2.91
CsBr	3.72	3.06	3.14	3.55	3.07
CsI	3.95		3.35	3.85	3.32
TlCl	3.32				2.55
TlBr	3.44				2.68
TlI <sup>1)</sup>	3.64				2.87

1) Above 175°C.

2) From ref. 23.

3) From ref. 21. Temperature not stated.

TABLE 5

FRACTIONAL INCREASE IN CHEMICAL SHIFT WITH  
TEMPERATURE (SOLID TlCl AND TlBr)

	$\frac{1}{3} \cdot \frac{1}{\Lambda_0} \cdot \frac{d^2 \Lambda}{dx^2} [\text{cm}^{-2}]$ (NaCl; LiCl)	$\frac{d\bar{u}^2}{dT} [\text{cm}^2/\text{deg.}^{-1}]$ (Tl)	$\frac{1}{\sigma_0} \cdot \frac{d\sigma}{dT} [\text{deg.}^{-1}]$	
			calc.	obs. (cf. tb. 1)
TlCl	4.3 x 10 <sup>16</sup>	2.7 x 10 <sup>-20</sup>	1.2 x 10 <sup>-3</sup>	1.4 x 10 <sup>-3</sup>
TlBr		3.4 x 10 <sup>-20</sup>	1.5 x 10 <sup>-3</sup>	0.55 x 10 <sup>-3</sup>

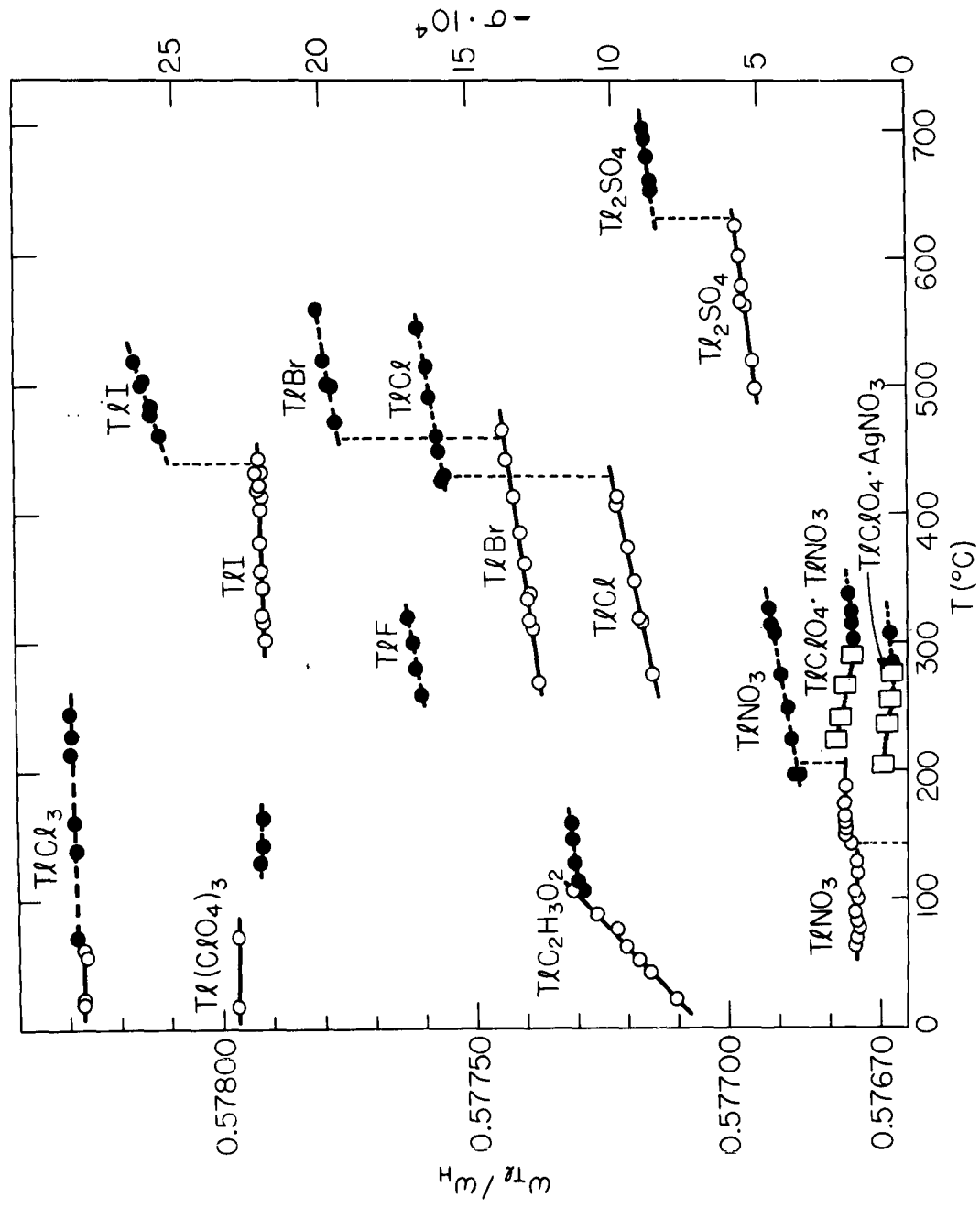

Fig. 1

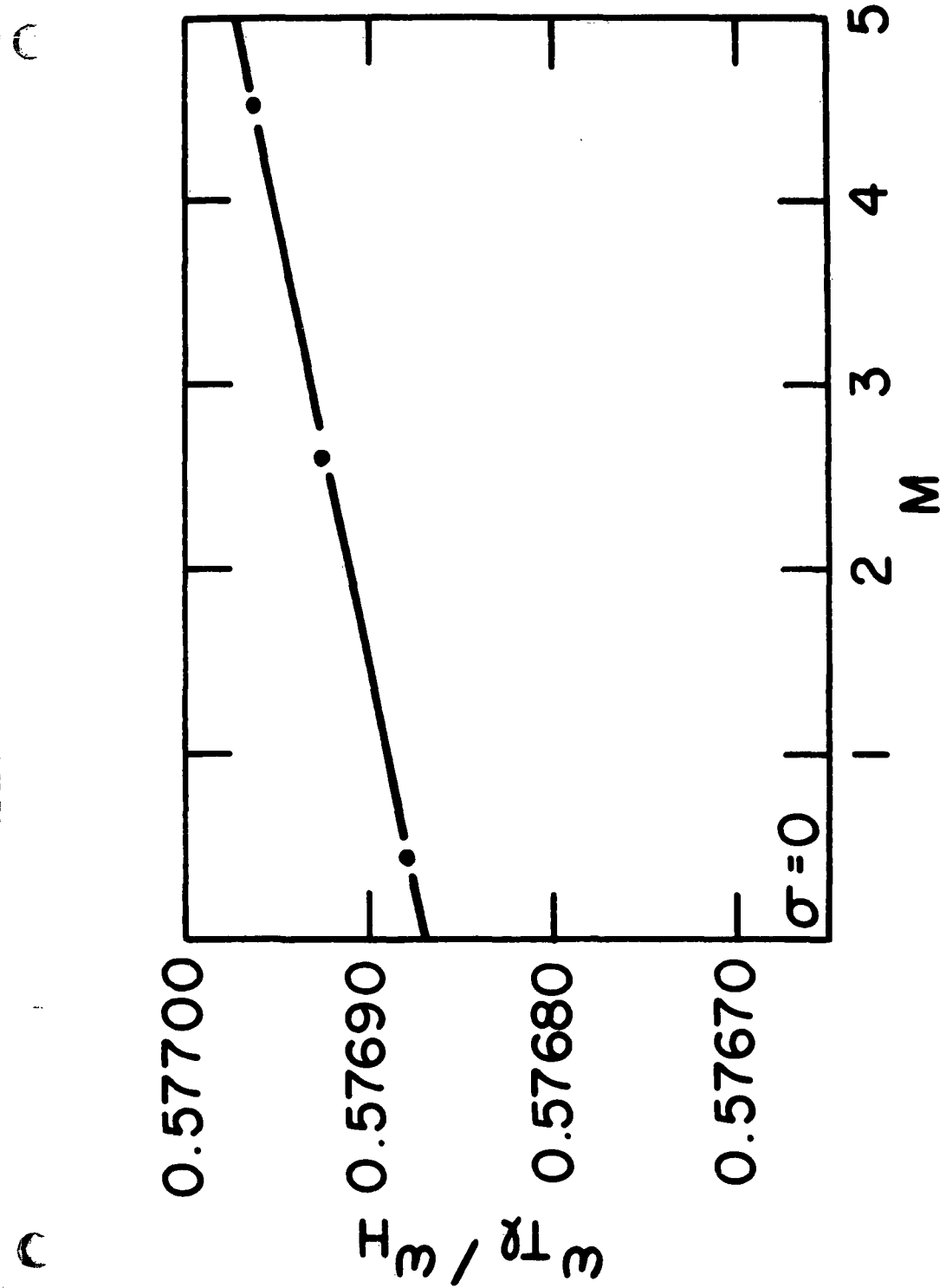
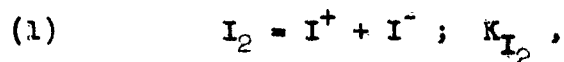

Fig.2

We investigated the conductance of the following solutes in molten iodine: potassium iodide, thallos iodide, silver iodide, stannic iodide, indium triiodide, gallium triiodide, iodine monochloride, and iodine monobromide, with results that are interpreted in terms of an ionic dissociation model. The following substances appeared to be insoluble in molten iodine, and had no significant effect upon its conductance: cuprous iodide, antimony (III) iodide, bismuth triiodide, zinc iodide, and cadmium iodide.

The conductance data are best explained in terms of an ionic model, in which the solvent ionizes according to the reaction:



where  $I^-$  represents not merely the iodide ion, but polyiodide species as well. Potassium iodide behaves as a ion-pair in molten iodine, dissociating according to the reaction:



The application of Kohlrausch's Laws to the conductance data, with the above two equilibria leads to the following values:

$$\begin{aligned} K_{I_2} &= 1.05 \times 10^{-7} \\ K_{KI} &= 8.5 \times 10^{-3} \\ \Delta\sigma_{I_2} &= 37.4 \text{ ohm}^{-1} \text{ cm}^2 \text{ eq}^{-1} . \end{aligned}$$

With these constants the experimental data may be fitted out to a concentration of  $1.0 \times 10^{-2} M$  KI in  $I_2$ .

At higher concentrations of potassium iodide the solution conductance rises much more rapidly than can be accounted for on the assumption of the above two equilibria, and it is clear that another significant process is entering:



Ion triples and presumably even higher multipolar species are favored by the low dielectric constant of iodine ( $\epsilon = 12$ ), and become increasingly important as the solute concentration is increased. For thallic iodide the ion pair and ion triple formation constants are  $K_{TlI} = 1.24 \times 10^{-3}$  and  $K_{Tl_2I} = 1.26 \times 10^3$ , respectively.

Solutes such as iodine monochloride and iodine monobromide differ from KI and TlI in their effect on the electrical conductance. Both cause a monotonic decrease in the conductance, by ionizing according to:

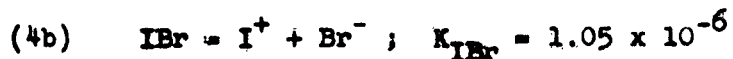
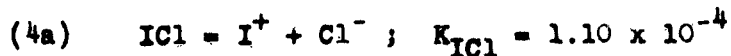

and repressing the solvent dissociation (Equation 1). The conductance data are well-fitted by the above constants and the following values for the equivalent conductances:

$$\begin{aligned} \Lambda_{oICl} &= 1.37 \text{ ohm}^{-1} \text{cm}^2 \text{eq}^{-1} \\ \Lambda_{oIBr} &= 7.40 \text{ ohm}^{-1} \text{cm}^2 \text{eq}^{-1} . \end{aligned}$$

FIGURE 1

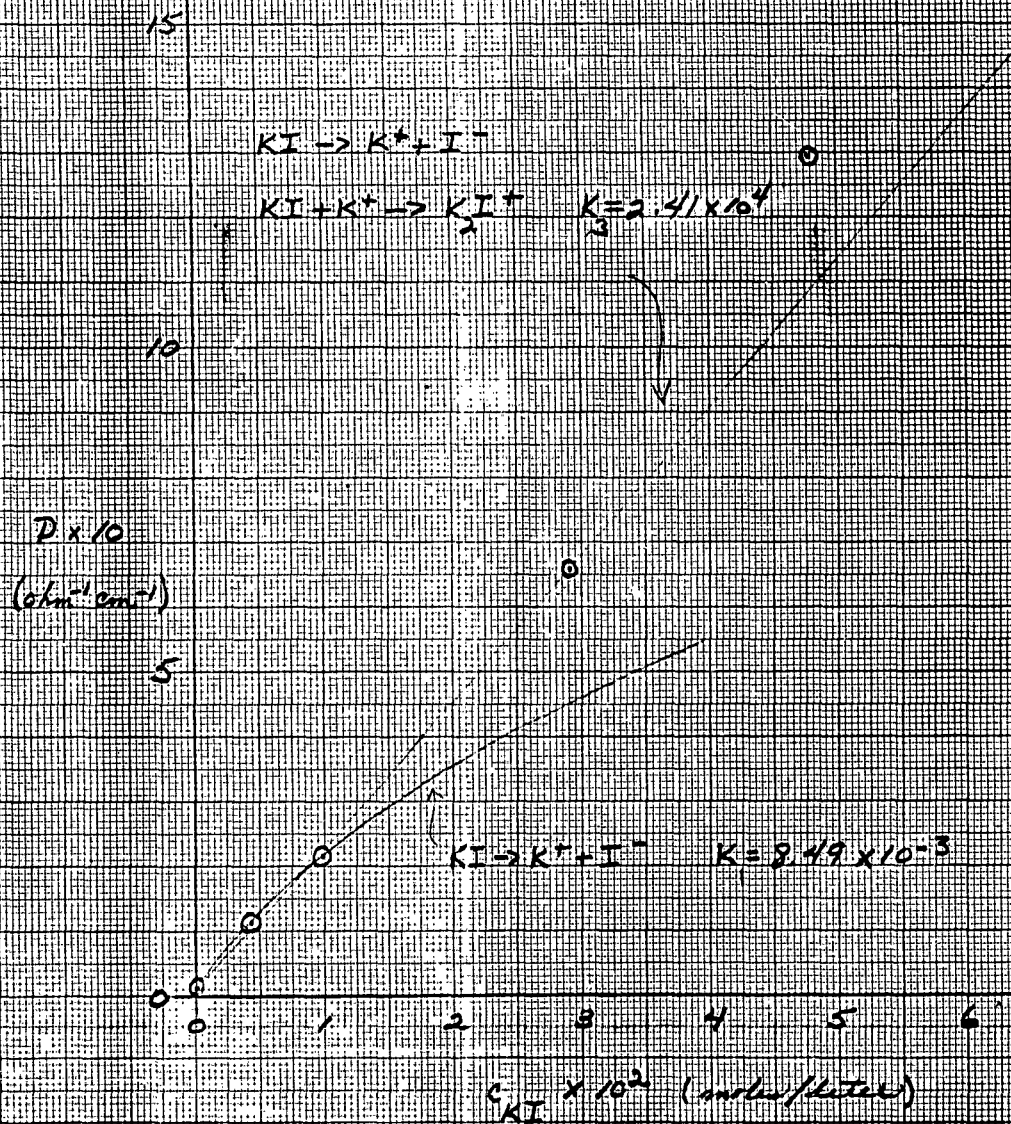

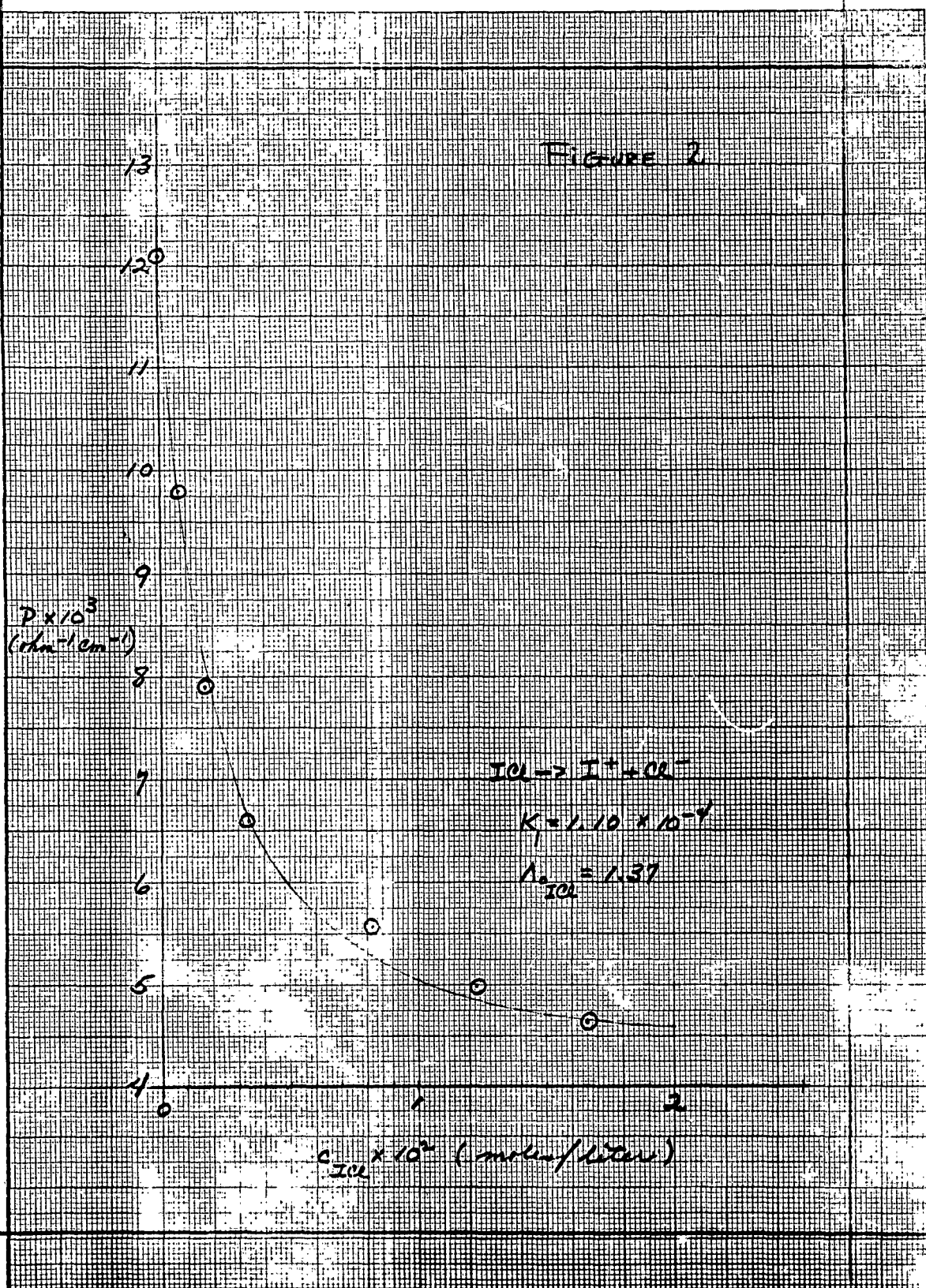

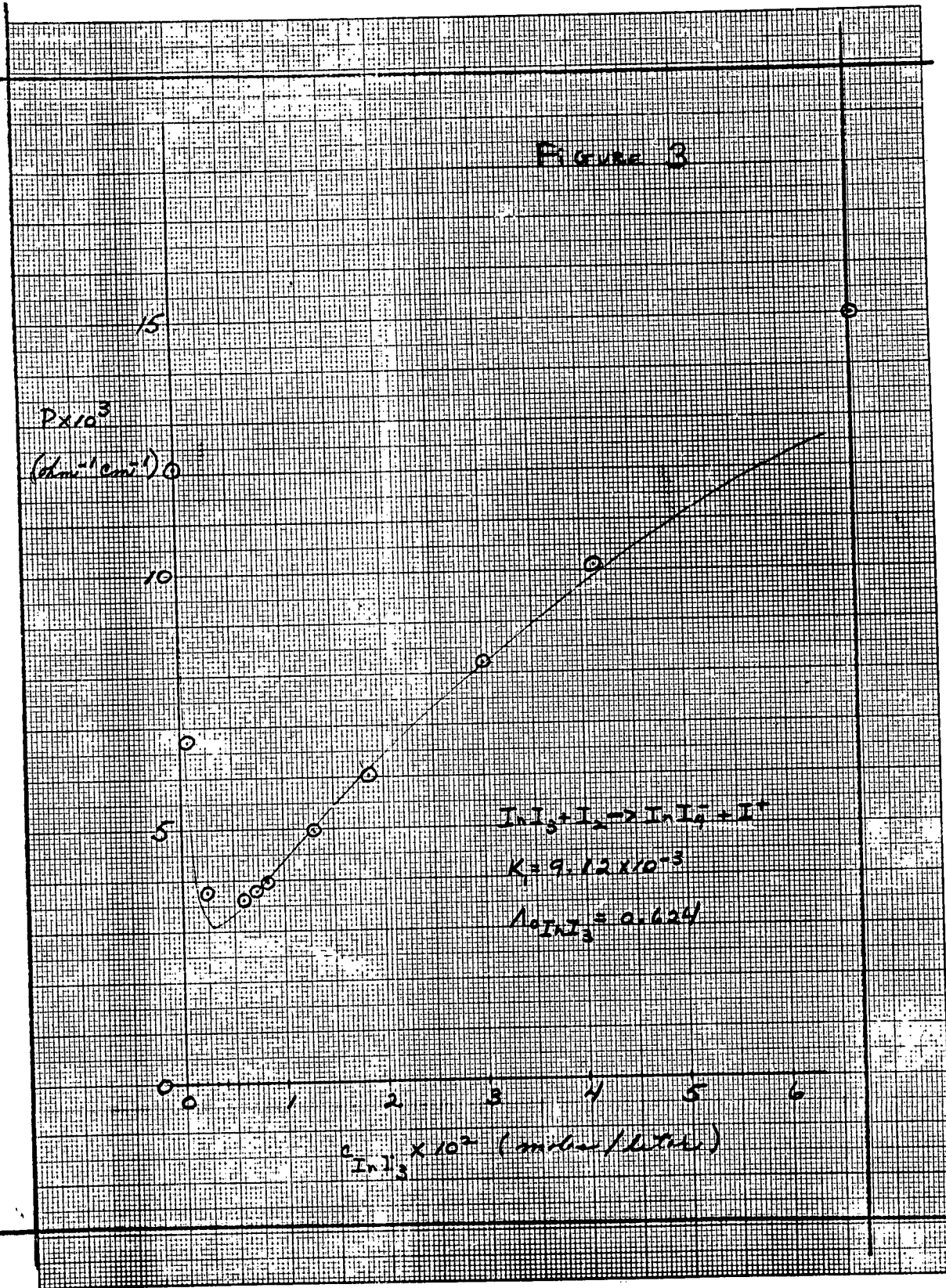

A third class of conductance behavior is shown by the solutes, indium triiodide and gallium triiodide, for both of which the solution conductance passes through a deep minimum at about  $3 \times 10^{-3}M$  and then gradually rises to values well in excess of that for pure iodine. The equilibria which appear to be involved are:

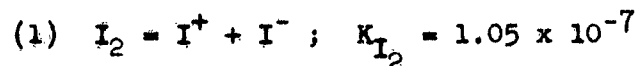
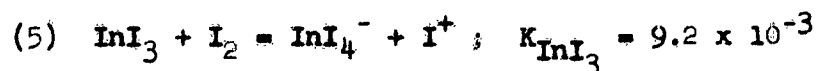

These values for the equilibrium constants, together with an assumed limiting equivalent conductance,  $\Lambda_{\infty} \text{InI}_3 = 0.624 \text{ ohm}^{-1} \text{ cm}^2 \text{ eq}^{-1}$ , describe the course of the conductance with solute concentration very well. Figures 1, 2 and 3 show the experimental data and the calculated conductance curves for KI, ICl, and InI<sub>3</sub>, fitted with the equilibrium constants and equivalent conductances given above.

### (3) SURFACE TENSION MEASUREMENTS.

We have been attempting to adapt the maximum bubble pressure method to the measurement of the surface tension of molten salts, and the results have been highly encouraging for bismuth tri-chloride. The following table lists our best values obtained to date:

<u>T(°C)</u>	<u><math>\sigma</math> (dyne cm<sup>-1</sup>)</u>
246.5	62.80
250.3	61.94
277.7	59.61
300.3	57.51
317.5	56.02
349.3	51.95
362.4	50.93
383.0	49.15
394.9	48.13

Efforts to extend these measurements to solutions containing added bismuth metal have been less successful. The lower oxidation state which is formed is highly susceptible to oxidation, and it has been difficult to have exact knowledge of the composition. They nevertheless show very clear deviations from additivity in the surface tension with pure salt and pure metal as the references. This confirms other evidence that the Bi/BiCl<sub>3</sub> solutions have no metallic properties, whatsoever. We wish to refine the measurements, however, and to extend them to the alkali/alkali metal halide solutions, in which there is better evidence for electronic and metallic behavior.

(4) MAGNETIC SUSCEPTIBILITY OF METAL/MOLTEN SALT SOLUTIONS

We are carrying out a study of the magnetic susceptibility of molten salts containing dissolved metal, for the purpose of learning more about the state of the valence electrons. As a starting point we take the simple view that each metal atom is ionized and the electrons are essentially free. At high electron concentrations they will occupy degenerate spin states, and only those electrons whose energy is at the top of the Fermi distribution should have unpaired spins. If such a free electron gas model is valid we should find the magnetic susceptibility to vary with concentration according to:

$$\chi = (8m/h^2)z^{1/3}N^{1/3}\mu_B^2(\pi V/3)^{2/3}$$

Doubtless this is an oversimplified model, which will need modification in the light of experiment. To provide data for the K/KCl and Na/NaCl systems, we have assembled a Gouy magnetic balance which is usable up to fields of 25 kilogauss and is sensitive to weight differences of 10 micrograms. The entire balance and furnace assembly can be evacuated in order to eliminate instabilities which arise from convection currents. We have plans to make the susceptibility tubes from thin-wall seamless nickel tubing, which is impervious to attack by the molten alkali metal/salt solutions. Temperatures will be well above the Curie temperature of nickel (300°C) for the measurements, and there will be only second-order paramagnetic corrections to make for the containing vessel.

The construction of an intricate internally wound water-jacketed tube furnace has been completed, and we shall begin measurements as soon as the seamless nickel tubing is received.

(5) ABSORPTION SPECTRA OF MOLTEN SALTS

Our studies of thallium salts suggest that the shift with temperature of the fundamental ultraviolet absorption band is closely related to the NMR shifts we have observed. Very little is known of the spectra of these simple salts beyond the qualitative fact that the long wave length band edge undergoes a red shift with temperature. We are modifying a spectrophotometer for high temperature absorbance studies of the band maxima to study the temperature dependence of the band maximum in detail. The problem of constructing quartz cells with very short path lengths we have solved.