

UNCLASSIFIED

AD **434698**

DEFENSE DOCUMENTATION CENTER

FOR

SCIENTIFIC AND TECHNICAL INFORMATION

CAMERON STATION, ALEXANDRIA, VIRGINIA



UNCLASSIFIED

NOTICE: ~~When~~ government or other drawings, specifications or other data are used for any purpose other than in connection with a definitely related government procurement operation, the U. S. Government thereby incurs no responsibility, nor any obligation whatsoever; and the fact that the Government may have formulated, furnished, or in any way supplied the said drawings, specifications, or other data is not to be regarded by implication or otherwise as in any manner licensing the holder or any other person or corporation, or conveying any rights or permission to manufacture, use or sell any patented invention that may in any way be related thereto.

64-11
COPY 18

CATALOGED BY DDC
AS AD NO

**CAMBRIDGE
ACOUSTICAL
ASSOCIATES, INC.**

**CONSULTANTS IN ENGINEERING
AND PHYSICS**

434698

MUTUAL AND SELF-RADIATION IMPEDANCES IN AN ARRAY
OF FREE-FLOODING, COAXIAL, SPACED RING TRANSDUCERS

Miguel C. Junger

16 March 1964

Technical Report U-178-46
Prepared for Office of Naval Research
Acoustics Programs - Code 465
Contract Nonr-2739(00)
Task NR 38-301

DDC
APR 13 1964
71518 8

129 MOUNT AUBURN STREET, CAMBRIDGE, MASSACHUSETTS

INTERNAL AND SELF-RADIATION IMPEDANCES IN AN ARRAY
OF FREE-FLOODING, COAXIAL, SPACED RING TRANSDUCERS

Miguel C. Jungor

16 March 1964

Technical Report U-178-48
Prepared for Office of Naval Research
Acoustics Program - Code 465
Contract Nonr-2739(00)
Task NR 187-301

Reproduction in Whole or in Part is Permitted
for any Purpose of the United States Government

CAMBRIDGE ACOUSTICAL ASSOCIATES, INC.
125 Mount Auburn Street
Cambridge, Massachusetts 02138

ACKNOWLEDGMENT

The help of various members of this firm, in particular of Mr. William Thompson, Jr., who checked the algebra, and of Dr. Alexander Silbiger, is gratefully acknowledged. Dr. J. E. Greenspon, of J G Engineering Research Associates, Baltimore, Maryland, has put the solution into practice by evaluating the Green's functions and obtaining quantitative results.

ABSTRACT

Expressions are derived for the mutual and self-radiation impedances between the elements in an array of coaxial, free-flooding, axially spaced ring transducers undergoing axisymmetric, radial vibrations. Fluid circulation through the gaps between elements and around the array extremities is accounted for in a formulation of this problem which was presented in a recent study of single "squirters". (CAA Report U-177-48). An integral equation is constructed which defines the unknown radial velocity distribution $\alpha(z)$ between elements and on the two semi-infinite cylindrical surfaces which bracket the array. It is shown that the radiation impedance is the sum of two components: (1) the impedance evaluated by means of the mathematical model originated by Robey, which assumes that the active array element is located on an infinite rigid cylindrical baffle, and (2) the impedance associated with the unknown velocity distribution $\alpha(z)$, which is therefore in the nature of a correction factor to Robey's impedance. Four methods are presented for obtaining the function $\alpha(z)$: a perturbation solution which can be used as the starting point in a more refined iteration-type solution, a finite-difference solution of the integral equation and finally a variational solution. Unfortunately a variational solution is less attractive in the case of the array problem than in the case of the single "squirter" because only the self-radiation impedance can be obtained directly from the stationary functional in terms of which this approach is formulated. The mutual impedances must be evaluated from the undetermined coefficients in terms of which the trial functions $\alpha(z)$ are expressed.

Dr. J. E. Greenspan, of J. C. Engineering Research Associates, evaluated the inverse Fourier transforms in terms of which the solution is presented, and obtained quantitative results both for the single cylinder and for the array. He will present this material in a separate report entitled "Axially Symmetric Green's Functions for Cylinders."

TABLE OF CONTENTS

	207 _a
Acknowledgment.	i
Abstract.	ii
List of Symbols	iv
List of Figures	vii
I Scope and Background of This Study	1
II Formulation of the Problem	3
III Radiation Impedance.	7
IV Formulation of the Problem in Terms of Symmetric (Even) and Antisymmetric (Odd) Velocity Distributions	8
V Perturbation and Iteration Solution of the Integral Equation	12
VI Finite-Difference Solution of the Integral Equation. . .	13
VII Variational Solution of the Integral Equation.	15
References.	27

SYMBOLS*

(Alternative subscripts, viz. a_0 , are used to condense two equations into one, the upper subscript on the left side of the equation being associated with the upper signs and subscripts on the right side of the equation, and vice versa.)

- mean radius of "squirter" (Fig. 2)
- a_1, a_0 inner and outer radius of "squirter," respectively (Fig. 2)
- b half-width of gap between elements (Fig. 1)
- c sound velocity in fluid medium
- $G_1, G_0, G_{1s}, G_{0s}, G_{1a}, G_{0a}, \Gamma_s, \Gamma_a, \Delta_s, \Delta_a$ Green's functions and related functions defined in Table 1
- H_m Hankel function of the first kind, of order m . [This function represents outgoing waves for the assumed time dependence $\exp(-i\omega t)$]
- h half wall thickness of "squirter" (Fig. 2)
- J_m Bessel function of order m
- k wave number, equal to ω/c
- k_r radial wave number, equal to $(k^2 - k_z^2)^{1/2}$
- k_z axial wave number
- L half-length of array element (Figs. 1 and 2)
- l half-length of array (Fig. 1)
- p sound pressure
- r, θ, z cylindrical coordinates
- U radial velocity amplitude of active array element (Figs. 3 and 4)
- $u_1(z), u_0(z), u(z)$ radial velocity distribution over cylindrical surfaces ($r=a_1$), ($r=a_0$) and ($r=a$) respectively, positive outward (Figs. 2 and 3)
- $u_s(z), u_a(z)$ symmetric (even) and antisymmetric (odd) component of velocity distribution over cylindrical surface ($r=a$) (Fig. 4)
- Z_{jj} self-radiation impedance of array element j , in units of force/velocity, equal to $[(Z_{jj})_r + (Z_{jj})_a]$
- Z_{jk} mutual radiation impedance experienced by array element k as a result of vibration of array element j , in units of force/velocity, equal to $[(Z_{jk})_r + (Z_{jk})_a]$
- $(Z_{jk})_r$ radiation impedance obtained from Robey's mathematical model for which $\alpha(z)=0$ (transducer elements located on infinite, rigid, cylindrical baffle)
- $(Z_{jk})_a$ correction factor associated with velocity distribution $\alpha(z)$, to be added to $(Z_{jk})_r$

*Other symbols are defined in the text.

- z_p region of z-axis consisting of the gaps between array elements, and of the two semi-infinite cylindrical surfaces ($z > l$, $z < -l$) which bracket the array (Fig. 3)
- z_{p+} positive half of z_p
- z_g location of midplane of gaps between neighboring array elements (Fig. 1)
- z_j location of midplane of active array element (Fig. 4)
- z_k location of midplane of array element (Fig. 1); in impedance calculations, location of inactive element (Fig. 4)
- $\alpha(z)$ radial velocity in the region z_p (Fig. 3) normalized to velocity amplitude U of active element in array
- $\alpha_s(z), \alpha_a(z)$ symmetric (even) and antisymmetric (odd) component of velocity distribution in region z_p , normalized to $U/2$
- B_1, B_0 coefficients in the relation of the velocity U of the mean transducer surface with, respectively, u_1 and u_0 , defined in Eq. II.3, ≈ 1 for small h/a
- $\delta(z-z')$ Dirac delta function, $\int_{-\infty}^{\infty} \alpha(z') \delta(z-z') dz' = \alpha(z)$
- ν Poisson's ratio of transducer material
- ρ density of fluid medium
- $\phi(r, z)$ velocity potential (outward velocity is $-\partial\phi/\partial r$); subscripts "i" and "o" refer, respectively, to regions $r \leq a_1$ and $r \geq a_0$; subscripts "s" and "a" refer, respectively, to symmetric (even) and antisymmetric (odd) components with regard to z
- ω circular frequency [with this notation, a massive reactance is negative; harmonic time dependence factor $\exp(-i\omega t)$ which multiplies the velocities and the potentials, has been suppressed throughout this report]

Table 1

GREEN'S FUNCTIONS AND RELATED FUNCTIONS

Symbol	Defined in Equation	Region where Applicable	Description
$Q_0(r, \theta, z-z')$	II.5 and 6a	$r > a$	General form of axisymmetric Green's function for which $\frac{\partial Q}{\partial z'} = 0$ at $z' = a$
$Q_1(r, \theta, z-z')$	II.5 and 6b	$r < a$	
$G_0(r, \theta, z-z')$	IV.7a	$r > a$	Even component of the Green's function, symmetric about $(z=0)$ and $(z'=0)$
$G_1(r, \theta, z-z')$	IV.7a	$r < a$	
$G_0(r, \theta, z-z')$	IV.7b	$r > a$	Odd component of the Green's function, antisymmetric about $(z=0)$ and $(z'=0)$
$G_1(r, \theta, z-z')$	IV.7b	$r < a$	
$\Gamma(z-z')$	II.16a		Linear combination of Q_0 and Q_1
$\Gamma_s(z-z')$	IV.11a	$r=a, z$ in region z_f	Linear combination of G_{0s} and G_{1s}
$\Gamma_a(z-z')$	IV.11a		Linear combination of G_{0a} and G_{1a}
$\Delta(z-z')$	II.16b		Linear combination of Q_0 and Q_1 tends to Γ for small h/a
$\Delta_s(z-z')$	IV.11b	$r=a, z$ outside region z_f	Linear combination of G_{0s} and G_{1s} tends to Γ_s for small h/a
$\Delta_a(z-z')$	IV.11b		Linear combination of G_{0a} and G_{1a} tends to Γ_a for small h/a

LIST OF FIGURES

	Page
1. FREE-FLOODING ARRAY OF SPACED RING TRANSDUCERS.	22
2. GEOMETRY OF TRANSDUCER ELEMENT.	23
3. RADIAL VELOCITY DISTRIBUTION SCHEMATICALLY ILLUSTRATED FOR FOUR-ELEMENT ARRAY.	24
4. SPLITTING OF VELOCITY DISTRIBUTION INTO SYMMETRIC (EVEN) AND ANTISYMMETRIC (ODD) COMPONENTS ILLUSTRATED FOR TWO ELEMENT-ARRAY. . .	25

I. Scope and Background of This Study

The purpose of this study is to evaluate the radiation impedances for the elements of an array consisting of identical free-flooding coaxial ring transducers vibrating in their radial, axisymmetric mode (Figures 1 and 2). The transducer elements are separated by equal axial distances, thus permitting the acoustic medium to flow both axially at the ends of the array and radially between elements. The impedances take into account the combined radiation loading acting on the inner and outer faces of individual transducer elements, when only one element in the array is active. The result of this study will thus be in the form of self- and mutual impedances of the array elements. Computations will be performed in the resonant frequency range of the transducer elements, the variable parameter being element spacing. Even though this study was stimulated by the promising experimental results recently obtained by the U.S. Naval Research Laboratory on an array of magnetostrictive ring transducers, the present analysis is not limited to magnetostrictive transducers nor, in fact, to free-flooding, axially spaced elements. When combined with the analysis of individual free-flooding or solid cylindrical radiators presented in an earlier report,¹ the present analysis can be applied to the evaluation of mutual impedances of ring and piston elements on a cylindrical baffle of finite length.

The array analysis can be followed independently of reference 1 if the reader is willing to accept without proof certain results derived therein. It was shown in this earlier study that the radiation impedances of an isolated transducer element can be expressed as the sum of two components:

$$Z = Z_r + Z_o \quad (I.1)$$

Z_r is the impedance computed by Robey,² Greenspon,^{3,4} and Sherman⁴ from Robey's mathematical model which is frequently used for cylindrical transducers. This model assumes that the radiating surface is extended to infinity by rigid cylindrical baffles which prevent circulation of the fluid around the transducer edges.⁵ This assumption, in combination with a Green's function constructed so as to have its radial derivative $\partial G/\partial r'$ vanish on the outer transducer surface ($r'=a$),

*The radiation loading on the inside of a free-flooding cylindrical transducer was also studied by Robey by means of two different models, which unfortunately also place restrictions on the fluid flow around the transducer edges.^{6,7}

eliminates the need of solving an integral equation to obtain the potentials. With this model an expression for the far field potential can be obtained analytically in closed form.⁵ The impedance Z_{α} in Eq. I.1 is in the nature of a correction factor associated with the radial flow velocity distribution $\alpha(z)$ across the cylindrical surface extending the transducers. Z_{α} is in the form of an integral whose integrand is proportional to $\alpha(z)$. The function $\alpha(z)$ satisfies a non-homogeneous Fredholm integral equation. Unfortunately a direct solution of this equation is not practicable. The analytical effort is therefore mostly directed at approximating the unknown function $\alpha(z)$.

In ref. 1 a variational technique was developed which parallels the Levine-Schwinger variational procedure for computing scattering cross sections in diffraction problems.* In this procedure, a functional $J[\alpha]$ is constructed from the integral equation. This functional can be shown to be stationary with respect to first order variations about the solution $\alpha(z)$ of the integral equation. If the ratio of transducer wall thickness to radius is small, the stationary value of $J[\alpha]$ is proportional to Z_{α} . A Rayleigh-Ritz-type calculation is used to compute Z_{α} , starting with a trial function for $\alpha(z)$. The most common use of the Rayleigh-Ritz method is the evaluation of the natural frequencies of a vibrating system. These frequencies are the roots of the determinant of the coefficients in a set of simultaneous homogeneous equations derived from a variational principle. The natural frequencies can therefore be evaluated without having to compute the undetermined coefficients in the assumed modal configuration of the vibrating body. In the analysis of the single, thin-walled "squitter," Z_{α} can be similarly obtained without previously solving for the unknown coefficients in terms of which $\alpha(z)$ has been expressed. Unfortunately, only its self-radiation impedance can be determined in this fashion when the transducer is an element in an array. In order to evaluate the mutual impedances, the set of simultaneous algebraic equations derived from the variational principle must be solved for the unknown coefficients in the trial function $\alpha(z)$. Thus, while in the single transducer problem the variational method is considerably more efficient than alternative methods for solving the integral equation, this is not the case in the array problem.

We will therefore present several other techniques for dealing with the integral equation. Experience with numerical calculations will show which

*A comprehensive bibliography of variational analyses of diffraction problems is given in the bibliography of ref. 1.

procedure is most efficient for a given combination of array parameters. One of the four techniques here presented involves finite-difference calculations. Even though such calculations have recently been used by various authors^{8,9} to solve the Helmholtz integral equation formulated in terms of the free-space Green's function, their formulation of the problem is basically different from the present one. In references 8 and 9, the unknown function in the integral equation is the potential on the solid surfaces which constitute the boundaries of the acoustic medium. In the case of an array, these surfaces would include all inactive as well as active array elements. In the analysis presented here, the unknown function is $u(z)$, the radial velocity distribution in the annular space between the ring elements and in the two semi-infinite annular spaces extending the array. This unknown function $u(z)$ makes a less important contribution to the radiation impedance than does the unknown potential over the transducer surfaces in the above-mentioned analyses. A comparable accuracy in the impedance calculations can therefore be expected from the present approach using a coarser finite-difference spacing.

Quantitative results will be presented in a separate report by Dr. J. E. Greenspon, of J G Engineering Research Associates, entitled "Axially Symmetric Green's Functions for Cylinders." Dr. Greenspon is obtaining numerical results for the transducer parameters corresponding to the EB array.

II. Formulation of the Problem

Following Robey's example the potentials are expressed in terms of two Green's functions whose radial derivatives vanish on one or the other of the two infinite concentric cylindrical surfaces on which the inner and outer transducer faces lie. Two potentials are thus constructed ϕ_0 , in the outer region $r > a_0$, and ϕ_1 in the inner, cylindrical region $r < a_1$ (Fig. 2). These potentials are expressed in terms of the radial velocity distributions $u_1(z)$ and $u_0(z)$ over these two coaxial cylindrical boundaries:^a

$$\phi_0(r,z) = \pm 2\pi a_0 \int_{-\infty}^{\infty} u_0(z') G_0(r, a_0, z-z') dz' \quad (\text{II.1})$$

^aHere and elsewhere in this report alternative subscripts and signs have been used to condense two equations into one, the upper subscript on the left side of the equation being associated with the upper signs and subscripts on the right side of the equation, and vice versa.

The velocity vanishes over the inactive transducer surface and equals a known constant, say U in the region where the active transducer is located. The analytical difficulty lies in the fact that the radial velocities are known only on the transducer surfaces (Fig. 3). Before defining the Green's functions it is convenient to express the velocities $u_1(z)$ and $u_0(z)$ in terms of the velocity $u(z)$ of the mean surface ($r=a$). For this purpose we assume an incompressible potential in the annular space $a_1 < r < a_0$. This implies that the ratio of wall thickness to acoustic wavelength is negligible. With this assumption, the balance of mass inflow and outflow yields the following relations between velocities:

$$u_1(z) = u(z) \left(1 \pm \frac{h}{a}\right)^{-1}, \quad \text{for } z \text{ in region } z_f. \quad (\text{II.2a})$$

The region z_f encompasses those portions of the annular space ($a_1 < r < a_0$) which contain acoustic fluid, rather than transducer elements. The region z_f thus includes the gaps between the array elements and the two semi-infinite annuli $z < l$ and $z > l$, which extend the array:

$$\int_{z_f} dz = \int_{-\infty}^{-l} dz + \sum_g \int_{z_g-b}^{z_g+b} dz + \int_l^{\infty} dz$$

where z_g is the coordinate of the plane of symmetry of a gap between two neighboring array elements. The values of z_g are given in the Table in Fig. 1. The coordinates z_k of the plane of symmetry of the elements are also given in this Table. The velocity of the inner and outer transducer faces are related to the velocity of the mean transducer surface as follows:

$$u_1(z) = u(z) \beta_1 \left(1 \pm \frac{h}{a}\right)^{-1} \quad \text{for } z_j-L < z < z_j+L \quad (\text{II.2b})$$

where the coefficients β embody the Poisson's ratio of the transducer material:

$$\begin{aligned} \beta_1 &= \left(1 \pm \frac{h}{a}\right) \left(1 \mp \frac{h}{va}\right) && \text{for piezoelectric transducers} \\ \beta_1 &= \left(1 \pm \frac{h}{a}\right) \left(1 \mp \frac{v^2 h}{a}\right) && \text{for magnetostrictive transducers} \end{aligned} \quad (\text{II.3})$$

¹The time dependence $\exp(-i\omega t)$ has been suppressed throughout this report for the sake of brevity.

²It was pointed out in ref. 1 that compressibility of the fluid in the annular region could be included in the analysis but that this would result in two coupled integral equations instead of a single integral equation. In the case of the NPL magnetostrictive array, the ratio of wall thickness to acoustic wavelength is 0.07. The assumption of an incompressible potential is therefore justified within the limits of accuracy required for design purposes.

The subscript j will be used for the active transducer, and the subscript k for the inactive transducers. The origin of the z -coordinate is located in the plane of symmetry of the array.

The radial velocity distribution over the mean cylindrical surface, ($r=a$), is expressed as follows (see Fig. 3):

$$\begin{aligned} u(z) &= U \quad \text{on active array element; } z_j - L < z < z_j + L \\ &= \bar{U}(z) \quad \text{for } z \text{ in region } z_j \\ &= 0 \quad \text{on inactive array elements, } z_k - L < z < z_k + L \quad (\text{see Table} \\ &\quad \text{in Fig. 1}) \end{aligned} \quad (\text{II.4})$$

The unknown function $G(z)$ is, in general, complex.

The Green's functions for the two integrals in Eq. II.1 are in the form of inverse Fourier transforms:

$$G_0(r, a_0, z-z') = \frac{1}{2\pi} \int_{-\infty}^{\infty} G_0(r, a_0, k_z) \exp[ik_z(z-z')] dk_z \quad (\text{II.5})$$

where the transforms of the Green's function are

$$G_0(r, a_0, k_z) = \frac{1}{2\pi a_0} \frac{H_0(k_z r)}{k_z H_1(k_z a_0)} \quad (\text{II.6a})$$

$$G_1(r, a_1, k_z) = -\frac{1}{2\pi a_1} \frac{J_0(k_z r)}{k_z J_1(k_z a_1)} \quad (\text{II.6b})$$

It can be verified that

$$\left. \frac{\partial G_0}{\partial r'} \right|_{r'=a_0} = 0$$

The potentials can be obtained by evaluating the inverse Fourier transforms, Eqs. II.5, and then performing the z' -integration indicated in Eq. II.1. Alternatively, the order of integration can be reversed. When Eqs. II.5 are substituted in Eq. II.1, the z' -integration can be performed first, by making use of the definition of the Fourier transform of the velocity distribution:

$$u(k_z) = \int_{-\infty}^{\infty} u(z') \exp(-ik_z z') dz' \quad (\text{II.8})$$

The potentials in Eq. II.1 can then be written in the form of an inverse Fourier transform:

$$\phi_1(r, z) = \frac{1}{2\pi} \int_{-\infty}^{\infty} G_1(r, a_1, k_z) u(k_z) \exp(ik_z z) dz \quad (\text{II.9})$$

As the development of this analysis need not be specialized to one or the other of these procedures, their relative convenience can be compared after more experience has been obtained in the evaluation of numerical results.

When we substitute Eqs. II.2 and 4 in Eq. II.1, we can express the potentials generated by the vibrations of the j th element of the array as follows:

$$\phi_1(r, z) = \frac{1}{2\pi} \int_{-\infty}^{\infty} 2\pi a U \left[\int_{z_j-L}^{z_j+L} G_1(r, a_1, z-z') dz' + \int_{z_f}^{\infty} \alpha(z') G_1(r, a_1, z-z') dz' \right] \exp(ik_z z) dz \quad (\text{II.10})$$

The unknown velocity distribution $\alpha(z')$ in these integrals is defined by the requirement that at every location the pressure differential between the concentric cylindrical surfaces ($r=a_1$) and ($r=a_0$) balance the radial component of the inertia force exerted by the fluid in the annular region between these two surfaces. The radial acceleration averaged over the radial thickness of the annulus is, taken positive outward

$$\ddot{u}(z) = -i\omega \alpha(z) \quad \text{for } z \text{ in region } z_f \quad (\text{II.11})$$

The radial component of the inertia force associated with a differential volume element $2\pi a_0 a_1 dz$ of the fluid annulus is therefore

$$dF(z) = 2\pi i \omega \alpha(z) \rho a_0 a_1 dz \quad (\text{II.12})$$

The outward force associated with the pressure differential is

$$dF(z) = [a_1 p_1(z) - a_0 p_0(z)] 2\pi dz \quad (\text{II.13a})$$

In terms of the potentials and of the mean radius and shell thickness this becomes

$$dF(z) = -2\pi \rho a \left[\left(1 - \frac{h}{a}\right) \phi_1(a_1, z) - \left(1 + \frac{h}{a}\right) \phi_0(a_0, z) \right] dz \quad (\text{II.13b})$$

When we set the sum of Eqs. II.12 and 13b, equal to zero, as required by d'Alembert's principle, we obtain the following relation between the potentials

and the unknown velocity distribution $\alpha(z)$:

$$\left(1 + \frac{h}{a}\right) \phi_0(a_0, z) - \left(1 - \frac{h}{a}\right) \phi_1(a_1, z) = -2hU\alpha(z) \quad \text{for } z \text{ in region } z_f \quad (\text{II.14})$$

For two of the configurations analyzed in reference 1, viz. the infinitely thin-walled, cylindrical radiator, and the solid cylinder, the right hand side of this equation vanishes and Eq. II.14 reduces to a continuity requirement of ϕ_1 and ϕ_0 on the surface ($r=a$). When we substitute the expression for the potentials, Eqs. II.10, in Eq. II.14 we obtain the non-homogeneous Fredholm equation which defines the unknown function $\alpha(z)$:

$$\int_{z_f} \left[\Gamma(z-z') + \frac{h}{a\kappa} \Delta(z-z') \right] \alpha(z') dz' = - \int_{z_j-L}^{z_j+L} \Delta(z-z') dz', \quad \text{for } z \text{ in region } z_f \quad (\text{II.15})$$

In this equation the symbols Γ and Δ have been used to represent two linear combinations of the Green's functions G_1 and G_0 :

$$\Gamma(z-z') = \left(1 + \frac{h}{a}\right) G_0(a_0, a_0, z-z') + \left(1 - \frac{h}{a}\right) G_1(a_1, a_1, z-z') \quad (\text{II.16a})$$

$$\Delta(z-z') = \beta_0 \left(1 + \frac{h}{a}\right) G_0(a_0, a_0, z-z') + \beta_1 \left(1 - \frac{h}{a}\right) G_1(a_1, a_1, z-z') \quad (\text{II.16b})$$

Having thus derived the integral equations which $\alpha(z)$ must satisfy, we proceed to express the impedances in terms of this same velocity distribution $\alpha(z)$.

III. Radiation Impedance

The radiation loading exerted by the j th element of the array on the k th element is obtained by integrating over the surface of the latter the pressure differential, Eq. II.13b, where the potentials are associated exclusively with the motion of the j th transducer element:

$$z_{jk} = - \frac{2\pi a i \rho_0 c}{U} \int_{z_k-L}^{z_k+L} \left[\left(1 + \frac{h}{a}\right) \phi_0(a_0, z) - \left(1 - \frac{h}{a}\right) \phi_1(a_1, z) \right] dz \quad (\text{III.1})$$

A radially inward directed radiation load is positive in this notation. When we substitute the expression for the potentials, Eq. II.10, and making use of the abbreviations for combinations of Green's functions, Eqs. II.16, we finally obtain

the following expression for the radiation impedance

$$Z_{jk} = - (2\pi a)^2 \rho_0 \int_{z_k-L}^{z_k+L} \left[\int_{z_j-L}^{z_j+L} \Delta(z-z') dz' + \int_{z_f} \alpha(z') \Gamma(z-z') dz' \right] dz \quad (\text{III.2})$$

As in the case of the self-impedance of the single transducer, the mutual impedances are seen to be the sum of two components: (1) the impedance obtained from Robey's mathematical model:

$$(Z_{jk})_r = - (2\pi a)^2 \rho_0 \int_{z_k-L}^{z_k+L} \int_{z_j-L}^{z_j+L} \Delta(z-z') dz' dz \quad (\text{III.3})$$

and (2) an impedance component associated with the unknown velocity distribution $\alpha(z)$:

$$(Z_{jk})_\alpha = - (2\pi a)^2 \rho_0 \int_{z_k-L}^{z_k+L} \int_{z_f} \alpha(z') \Gamma(z-z') dz' dz \quad (\text{III.4})$$

The problem is thus to find the solution $\alpha(z)$ of the integral equation, Eq. II.15 and to substitute this solution in the above expressions for the radiation impedances. The velocities of the individual transducer elements can then be obtained from the usual array analysis. Finally, the velocity distribution $\alpha(z)$ can be used to obtain the far field potentials from the expressions given for the single "squitter" in Sections VII and VIII of ref. 1.

IV. Formulation of the Problem in Terms of Symmetric (Even) and Antisymmetric (Odd) Velocity Distributions

In Robey's mathematical model the velocity distribution, and hence the potential, are always symmetric about the plane of symmetry of the active transducer ring. In the present model, which allows for fluid flow between elements, this is not the case except when an active element is located at the center of the array. In two of the four solutions presented in Sections V to VII, it is advantageous to consider the velocity U of the active array element as the resultant of two component velocity distributions, one of which is symmetric about the plane of symmetry of the array, ($z=0$), and the other antisymmetric. As seen from Fig. 4, this amounts

to considering the velocity U of the active element,

$$u(z) = U \quad \text{for } z_j - L < z < z_j + L \quad (\text{IV.1a})$$

as the superposition of (1) the velocity distribution associated with two elements located, respectively, at z_j and $-z_j$, excited in phase, with half the original amplitude

$$u_s(z) = \frac{U}{2} \quad \text{for } z_j - L < z < z_j + L \quad (\text{IV.1b})$$

and (2) the velocity distribution of the same two elements excited out of phase

$$u_a(z) = \frac{U}{2} \quad \text{for } z_j - L < z < z_j + L$$

$$u_a(z) = -\frac{U}{2} \quad \text{for } -z_j - L < z < -z_j + L \quad (\text{IV.1c})$$

For a centrally located element, the antisymmetric velocity distribution does not arise, and

$$u(z) = u_s(z) = U \quad \text{for } -L < z < L \quad (z_j=0) \quad (\text{IV.1d})$$

Because of the linearity of the problem, we can solve independently the symmetric case, Eq. IV.1b, which gives rise to a symmetric potential,

$$\phi_s(r, z) = \phi_s(r, -z) \quad (\text{IV.2a})$$

and the antisymmetric case, Eq. IV.1c, which gives rise to an antisymmetric potential,

$$\phi_a(r, z) = -\phi_a(r, -z) \quad (\text{IV.2b})$$

The unknown velocity distributions corresponding to these two potentials satisfy similar symmetry relations:

$$\alpha_s(z) = \alpha_s(-z)$$

$$\alpha_a(z) = -\alpha_a(-z) \quad (\text{IV.3})$$

It is advantageous to normalize the two components of the unknown velocity distribution to $U/2$. With this convention, and using Eqs. IV.3, the velocity distribution in region z_r can be expressed as

$$\left. \begin{aligned} u(z) &= \frac{U}{2} [\alpha_s(z) + \alpha_a(z)] \quad \text{for } z > 0 \\ u(z) &= \frac{U}{2} [\alpha_s(z) - \alpha_a(z)] \quad \text{for } z < 0 \end{aligned} \right\} \text{in region } z_r \quad (\text{IV.4})$$

It is seen from Eqs. IV.2 and 3 that if ϕ_s and α_s satisfy the integral equations, Eqs. II.14 and 15, in the positive half of the region z_p , they automatically satisfy these equations in the negative half of z_p . The same applies to ϕ_a and α_a . We can therefore confine the integral equation to the positive half of the region z_p , which will be designated henceforth by the symbol z_{p+} . The advantage in splitting the potential into symmetric and antisymmetric components results from the fact that, with the finite-difference and variational techniques described below, it is less laborious to satisfy two separate integral equations in the subregion z_{p+} , than to satisfy one integral equation over all of the region z_p .

The resultant potential generated by the active transducer located at z_j is

$$\phi(r, z) = \phi_s(r, z) + \phi_a(r, z) \quad (IV.5a)$$

which, in view of Eqs. IV.2a, can be written as

$$\phi(r, \pm z) = \phi_s(r, +|z|) \pm \phi_a(r, +|z|) \quad (IV.5b)$$

We need therefore only evaluate the two component potentials for positive values of z to obtain information on the resultant potential over the whole range of z .

Restriction of the analysis to positive values of z does not interfere with obtaining all of the desired radiation impedances. The mutual impedance is determined only by the separation $|z_j - z_k|$ between the active and inactive array element. The self-impedance is the same for elements symmetrically located at z_j and $-z_j$. We can therefore restrict the analysis to active elements for which $z_j \geq 0$, but z_k can of course be negative as well as positive.

We shall now derive the component Green's functions which are applicable to the symmetric and antisymmetric potentials. The Green's functions in Eq. II.5 can be expressed in terms of an inverse Fourier cosine transform by noting that the imaginary component of the exponential does not contribute to the value of the integral, because the Green's function is even in k_z :

$$G_0(r, a_0, z-z') = \frac{1}{\pi} \int_0^{\infty} G_0(r, a_0, k_z) \cos[k_z(z-z')] dk_z \quad (IV.6)$$

Expanding the cosine in the integrand, the Green's function can be written as the sum of a component which is even, or symmetric about both $z=0$ and $z'=0$, and of a component which is odd, or antisymmetric:

$$G_0(r, a_0, z-z')_s = \frac{1}{\pi} \int_0^{\infty} G_0(r, a_0, k_z) \cos(k_z z) \cos(k_z z') dk_z \quad (IV.7a)$$

$$\varepsilon_0(r, a_0, z-z')_z = \frac{1}{\pi} \int_0^{\infty} G_0(r, a_0, k_z) \sin(k_z z) \sin(k_z z') dk_z \quad (\text{IV.7b})$$

If both the Green's function and the velocity distribution, in the integrand of Eq. II.1, are expressed as a sum of symmetric and antisymmetric terms, the cross terms are found not to contribute to the value of the integral:

$$\phi_0(r, z) = \pm 2\pi a_0 \int_{-\infty}^{\infty} [u_0(z')_s \varepsilon_0(r, a_0, z-z')_s + u_0(z')_a \varepsilon_0(r, a_0, z-z')_a] dz' \quad (\text{IV.8})$$

The two products in the integrand thus correspond respectively to ϕ_s and ϕ_a . Since the contribution of the integral to these two potentials is the same for the positive and negative halves of the z' -axis, these two components can finally be written as

$$\phi_0(r, z)_s = \pm 4\pi a_0 \int_0^{\infty} u_0(z')_s \varepsilon_0(r, a_0, z-z')_s dz' \quad (\text{IV.9a})$$

and

$$\phi_0(r, z)_a = \pm 4\pi a_0 \int_0^{\infty} u_0(z')_a \varepsilon_0(r, a_0, z-z')_a dz' \quad (\text{IV.9b})$$

The integration over z' can be performed before the k_z -integration indicated in Eqs. IV.7 by making use of the Fourier transforms of u_s and u_a , respectively:

$$\phi_0(r, z)_s = \pm 2a_0 \int_0^{\infty} G_0(r, a_0, k_z) u(k_z)_s \cos k_z z dk_z \quad (\text{IV.10a})$$

$$\phi_0(r, z)_a = \pm 2a_0 \int_0^{\infty} G_0(r, a_0, k_z) u(k_z)_a \sin k_z z dk_z \quad (\text{IV.10b})$$

The linear combinations of Green's functions, Eqs. II.16 used in the integral equation, Eq. II.15 can now also be split into symmetric and antisymmetric components:

$$\Gamma_{\frac{h}{a}}(z-z') = (1 + \frac{h}{a}) \varepsilon_0(a_0, a_0, z-z')_{\frac{h}{a}} + (1 - \frac{h}{a}) \varepsilon_1(a_1, a_1, z-z')_{\frac{h}{a}} \quad (\text{IV.11a})$$

$$\Delta_{\frac{1}{2}}(z-z') = \beta_0 \left(1 + \frac{h}{a}\right) \xi_{\frac{1}{2}}(a_0, a_0, z-z')_{\frac{1}{2}} + \beta_1 \left(1 - \frac{h}{a}\right) \xi_{\frac{1}{2}}(a_1, a_1, z-z')_{\frac{1}{2}} \quad (\text{IV.11b})$$

The two component velocity distributions, α_s and α_a satisfy the two uncoupled integral equations which take the place of Eq. II.15:

$$\int_{z_{f+}}^{z_{f+}} [\Gamma_{\frac{1}{2}}(z-z') + \frac{h}{2\pi a} \delta(z-z')] \alpha_{\frac{1}{2}}(z') dz' = - \int_{z_{j-L}}^{z_{j+L}} \Delta_{\frac{1}{2}}(z-z') dz' \quad \text{for } z \text{ in region } z_{f+} \quad (\text{IV.12})$$

Robey's radiation impedance, Eqs. III.3, now becomes

$$(Z_{jk})_r = -(2\pi a)^2 \text{imp} \int_{z_{k-L}}^{z_{k+L}} \int_{z_{j-L}}^{z_{j+L}} [\Delta_s(z-z') + \Delta_a(z-z')] dz' dz \quad (\text{IV.13})$$

The correction factor associated with the radial velocity distribution $\alpha(z)$ is

$$(Z_{jk})_{\alpha} = -(2\pi a)^2 \text{imp} \int_{z_{k-L}}^{z_{k+L}} \int_{z_{f+}}^{z_{f+}} [\alpha_s(z') \Gamma_s(z-z') + \alpha_a(z') \Gamma_a(z-z')] dz' dz \quad (\text{IV.14})$$

If either z_k or z_j are zero then the antisymmetric terms Γ_a and Δ_a drop out of the integrands in Eqs. IV.13 and 14. If all the elements in the array are identical and driven with the same signal, the velocity distribution and hence the far field potential do not contain any antisymmetric components. We will now discuss four approaches to the solution of the integral equation.

V. Perturbation and Iteration Solution of the Integral Equation

In these two approaches nothing is gained by dealing separately with symmetric and antisymmetric velocity components. The crudest of the four approaches to be described is the perturbation solution in which we actually circumvent the need of solving the integral equation. This approach starts with the near field potentials associated with Robey's model. They are computed from Eq. II.10 where $\alpha(z')$ is set equal to zero. Designating these unperturbed potentials by $\psi^{(0)}$ and substituting them in Eq. II.14, we can solve directly for the perturbation solution for $\alpha(z)$

$$\alpha^{(0)}(z) = \frac{\left(1 + \frac{h}{a}\right) \psi^{(0)}(a_0, z) - \left(1 - \frac{h}{a}\right) \psi^{(0)}(a_1, z)}{-2hJ} \quad (\text{V.1})$$

When we substitute the unperturbed potentials as computed from Eqs. II.10, where $\alpha(z)$ has been set equal to zero, and using the Green's function combination in Eq. II.16b, Eq. V.1 can then be written more explicitly as:

$$\alpha^{(0)}(z) = -\frac{\pi a}{h} \int_{z_j-L}^{z_j+L} \Delta(z-z') dz' \quad (V.2)$$

In the component subregions of z_r which correspond to the gaps between the array elements, a somewhat more refined solution for $\alpha(z)$ can be obtained if one defines an effective radial annular width equal to the transducer wall thickness ($2h$) increased by a length Δh embodying the accession to inertia of a slit in a baffle. The introduction of an accession to inertia is not useful in any of the other approaches, where the potentials ϕ_0 and ϕ_1 themselves embody this reactive impedance component.

Since, for design purposes, we probably need a more accurate expression than the perturbation solution, we use the value $\alpha^{(0)}$, Eq. V.2, as a start for an iteration procedure. The first step consists in computing values for $\phi_0^{(1)}$ by substituting the perturbation solution $\alpha^{(0)}$ in Eq. II.10. When we substitute the potentials thus computed in the integral equation, Eq. II.15, we obtain the following more refined expression for $\alpha(z)$:

$$\alpha^{(1)}(z) = -\frac{\pi a}{h} \left[\int_{z_j-L}^{z_j+L} \Delta(z-z') dz' + \int_{z_r} \Gamma(z-z') \alpha^{(0)}(z') dz' \right] \quad (V.3)$$

This iteration can be repeated until the fluctuations of successive solutions $\alpha(z)$ are deemed sufficiently small. Convergence of this process can best be tested empirically by performing the actual numerical calculations and comparing the results of successive iterations with results obtained from the other approaches to the solution of the integral equation.

VI. Finite-Difference Solution of the Integral Equation

In this approach, the region z_r is divided into a number Q of subregions. Each subregion is identified by the coordinate z_q of its plane of symmetry. It is assumed that $\alpha(z)$ has a constant, generally complex, value of α_q in each one of these subregions. The axial dimension $2a_q$ of these subregions can be taken smaller

in the vicinity of the active transducer to account for the more rapid decay of $\alpha(z)$ near the radiating surface. The z_p -integral in the integral equation, Eq. II.15, is now replaced by a summation over the Q subregions. The integral equation must be satisfied at discrete points z_p in the region z_p :

$$2 \sum_{q=1}^Q d_q [\Gamma(z_p - z_q) + \delta_{pq} \frac{h}{2\pi a}] \alpha_q = - \int_{z_j-L}^{z_j+L} \Delta(z_p - z') dz' \quad (VI.1)$$

where δ_{pq} is the Kronecker delta function which equals 1 when $p=q$ and zero when $p \neq q$. If p is successively set equal to all values of q , from 1 to Q , a set of Q simultaneous linear equations in α_q is obtained. In this particular approach there is an obvious advantage at evaluating separately the symmetric and anti-symmetric velocity components. The two uncoupled integral equations, Eqs. IV.12 now give rise to two uncoupled sets of simultaneous linear equations. However, since the two integral equations, Eqs. IV.12, only extend over the positive half of the region z_p , the same finite-difference spacing results in $Q/2$ (instead of Q) simultaneous equations for $(\alpha_q)_s$, and in the same number of equations for $(\alpha_q)_a$. Thus comparable accuracy is achieved by solving two matrix equations of order $M=Q/2$, instead of the single matrix equation of order Q which must be solved if the velocity distribution is not split in this fashion. These matrix equations are of the form:

$$\begin{bmatrix} \frac{h}{2\pi a} + 2d_1 \Gamma_{\frac{h}{2}}(0) & 2d_2 \Gamma_{\frac{h}{2}}(z_1 - z_2) & \dots & 2d_M \Gamma_{\frac{h}{2}}(z_1 - z_M) \\ 2d_1 \Gamma_{\frac{h}{2}}(z_2 - z_1) & \frac{h}{2\pi a} + 2d_2 \Gamma_{\frac{h}{2}}(0) & \dots & \dots \\ \dots & \dots & \dots & \dots \\ 2d_1 \Gamma_{\frac{h}{2}}(z_M - z_1) & \dots & \dots & \frac{h}{2\pi a} + 2d_M \Gamma_{\frac{h}{2}}(0) \end{bmatrix} \begin{Bmatrix} (\alpha_{\frac{h}{2}})_1 \\ (\alpha_{\frac{h}{2}})_2 \\ \dots \\ (\alpha_{\frac{h}{2}})_M \end{Bmatrix} = \begin{Bmatrix} F_{\frac{h}{2}}(z_1) \\ F_{\frac{h}{2}}(z_2) \\ \dots \\ F_{\frac{h}{2}}(z_M) \end{Bmatrix} \quad (VI.2)$$

where

$$F_{\frac{h}{2}}(z_p) = \int_{z_j-L}^{z_j+L} \Delta_{\frac{h}{2}}(z_p - z') dz' \quad (VI.3)$$

Like the Green's functions of which they are composed, the functions $\Gamma(z-z')$ have a singularity at $z=z'$. The diagonal terms in the matrix do not, however, display a singularity since they are equivalent to an integral of $\Gamma(z-z')$ over z' which, like the potentials, is a well-behaved function.

When this matrix is solved for the values of α_m the radiation impedances Z_{jk} are obtained in the form of a summation

$$(Z_{jk})_{\alpha} = -2(2\pi a)^2 \text{imp} \sum_{m=1}^M d_m \int_{z_k-L}^{z_k+L} [\alpha_{sm} \Gamma_s(z-z_m) + \alpha_{am} \Gamma_a(z-z_m)] dz \quad (\text{VI.4})$$

VII. Variational Solution of the Integral Equation

As in the finite-difference solution, it will be found advantageous in the present approach to handle separately the symmetric and antisymmetric components of the unknown velocity distribution. Our purpose in this section is thus to find a variational solution to the uncoupled integral equations, Eqs. IV.12, which define the unknown velocity distributions α_s and α_a . The procedure is to construct functionals $J[\alpha]$ which are stationary with respect to first order variations of the solutions $\alpha_s(z)$ and $\alpha_a(z)$. The steps in deriving this functional parallel those presented in Ref. 1, Section V. Both sides of the integral equation are multiplied by $\alpha(z)$ and integrated with respect to z over the region z_{f+} . One thus obtains a relation between two functionals

$$B[\alpha_s] = -A[\alpha_s] \quad (\text{VII.1})$$

where

$$A[\alpha_s] = \int_{z_{f+}} \alpha_s(z) \left[\int_{z_j-L}^{z_j+L} \Delta_s(z-z') dz' \right] dz \quad (\text{VII.2a})$$

$$B[\alpha_s] = \int_{z_{f+}} \int_{z_{f+}} \alpha_s(z) [\Gamma_s(z-z') + \frac{h}{2\pi a} \delta(z-z')] \alpha_s(z') dz' dz \quad (\text{VII.2b})$$

When we divide both sides of Eq. VII.1 by $A^2[\alpha]$ and take their reciprocal, we obtain the following relation*

$$\frac{A^2[\alpha]}{B[\alpha]} = -A[\alpha] \quad (\text{VII.3})$$

*Subscripts s and a will be omitted in subsequent equations.

The functional which displays the desired stationary characteristics is defined by the left side of the above equation

$$J[\alpha] \approx \frac{A^2[\alpha]}{B[\alpha]} \quad (\text{VII.4})$$

The increment $\delta J[\alpha]$ associated with an increment $\delta\alpha$ can be written as:

$$\delta J[\alpha] = \{B[\alpha] + A[\alpha]\} \frac{2A[\alpha]}{B^2[\alpha]} \int_{z_1}^{z_2} \int_{z_1-L}^{z_2-L} K(z-z') \delta\alpha(z) dz' dz \quad (\text{VII.5})$$

For the details of this transformation, the reader is referred to ref. 1, Section V. The functional $J[\alpha]$ is stationary if $\delta J=0$. Since neither the ratio $2A/B^2$ nor the double integral is identically zero, the conditions required to make the increment $\delta J[\alpha]$ vanish is that the term in braces be zero. It can be verified that this amounts to requiring that the functionals $A[\alpha]$ and $B[\alpha]$ satisfy Eq. VII.1. This equation is derived from the integral equations, Eqs. IV.12. It is therefore satisfied by functions which are solutions of the integral equation. The functions which satisfy the integral equation therefore also make δJ vanish. We have thus shown that the functional defined in Eq. VII.4 is stationary with respect to variations $\delta\alpha$ about the solution $\alpha(z)$ of the original integral equation.

This variational principle can be used to obtain approximate values of the radiation impedance in much the same way that the Rayleigh-Ritz method yields expressions for natural frequencies of vibrating systems. The procedure was presented in detail in ref. 1, Section VI and will therefore only be briefly reviewed. In the Rayleigh-Ritz procedure a trial function for $\alpha(z)$ is constructed in terms of undetermined coefficients associated with various powers of z . It was shown that in the far field, $\alpha(z)$ must be of the form

$$\alpha(z) = \frac{\exp(ikz)}{|z|^2} \quad \text{for } |z| \text{ large} \quad (\text{VII.6})$$

In the near-field of the array, for values of z only slightly larger than l , a more rapid decay with increasing z can be assumed to simulate near field conditions. It is thus expedient to include a term proportional to z^{-3} . When the gaps between array elements are narrow, the radial velocity through these gaps can be taken equal to a constant, v_g , which of course differs from gap to gap. Phase shifts between the radial velocities in different gaps are taken into

account by the fact that the coefficients x_g are, in general, complex. Since splitting the velocity distribution into symmetric and antisymmetric components confines the integral equation to the subregion z_g , the trial function need be defined only for positive values of z . A trial function in the following form is thus obtained

$$\alpha(z) = \left(\frac{x_1}{z^3} + \frac{x_2}{z^2}\right) \exp(ikz) \quad \text{for } z > l \quad (\text{VII.7a})$$

$$\alpha(z) = x_g \quad \text{for } z_g - b < z < z_g, \text{ with } z_g \geq 0 \quad (\text{VII.7b})$$

(see Table in Fig. 1 for values of z_g). A refinement which will be required when the gaps between the array elements are large, involves taking into account the change of radial velocity within the width of each gap. Instead of Eq. VII.7b, we can now assume

$$\alpha(z) = x_{g0} + x_{g1}z \quad \text{for } z_g - b < z < z_g + b, \text{ with } z_g \geq 0 \quad (\text{VII.7c})$$

Experience with numerical calculations, and in particular comparison with the approaches described in sections V and VI, will indicate whether the radiation impedance is sensitive to the selection of the trial function $\alpha(z)$. Since the resultant velocity distribution is the sum of two trial functions α_+ and α_- , a fairly modest number of unknown coefficients allows considerable flexibility.

As an example, let us consider a three-element array embodying relatively narrow gaps. The trial function in Eqs. VII.7 now becomes

$$\alpha(z) = \left(\frac{x_1}{z^3} + \frac{x_2}{z^2}\right) \exp(ikz) \quad \text{for } z > 3L + 2b$$

$$\alpha(z) = x_3 \quad \text{for } L < z < L + 2b \quad (\text{VII.8})$$

By virtue of the variational principle derived above, the best values of the unknown coefficients are those which give a stationary value to the functional $J[\alpha]$:

$$\delta J[\alpha] / \delta x_n = 0 \quad \text{with } n = 1, 2, \text{ and } 3 \quad (\text{VII.9})$$

When we substitute the definition of $J[\alpha]$, Eq. VII.4, and multiply all terms by $B[\alpha]$, these equations become

$$2 \frac{\delta A[\alpha]}{\delta x_n} A[\alpha] - \frac{\delta B[\alpha]}{\delta x_n} J[\alpha] = 0, \quad \text{with } n = 1, 2, \text{ and } 3 \quad (\text{VII.10})$$

When the functionals $A[\alpha]$ and $B[\alpha]$, Eqs. VII.2 are evaluated in terms of Eq. VII.8, the former functional is found to be a linear function of the unknown coefficients in $\alpha(x)$, and the latter a quadratic function:

$$A[\alpha] = \sum_{n=1}^3 a_n x_n, \quad \frac{\partial A}{\partial x_n} = a_n \quad (\text{VII.11a})$$

$$B[\alpha] = \sum_{n=1}^3 (b_n x_n^2 + 2 \sum_{m=n}^3 b_{nm} x_n x_m)$$

$$\frac{\partial B}{\partial x_n} = 2b_n x_n + 2 \sum_{m=n}^3 b_{nm} x_m \quad (\text{VII.11b})$$

The coefficients a_n, b_n and b_{nm} are known, complex constants. When Eqs. VII.11 are substituted in the simultaneous variational equations, Eq. VII.10, a set of linear equations in the undetermined coefficients x_n is obtained:

$$(a_n^2 - b_n J[\alpha])x_n + \sum_{m=n}^3 (a_n a_m - b_{nm} J[\alpha])x_m = 0 \text{ for } n=1, 2, \text{ and } 3 \quad (\text{VII.12})$$

These equations being homogeneous, they admit non-trivial solutions only if the determinant of their coefficients vanishes. One thus obtains a characteristic equation which can be solved for $J[\alpha]$:

$$\begin{vmatrix} a_1^2 - b_1 J[\alpha] & a_1 a_2 - b_{12} J[\alpha] & a_1 a_3 - b_{13} J[\alpha] \\ a_1 a_2 - b_{12} J[\alpha] & a_2^2 - b_2 J[\alpha] & a_2 a_3 - b_{23} J[\alpha] \\ a_1 a_3 - b_{13} J[\alpha] & a_2 a_3 - b_{23} J[\alpha] & a_3^2 - b_3 J[\alpha] \end{vmatrix} = 0 \quad (\text{VII.13})$$

In contrast to the Rayleigh-Ritz natural frequency calculation, which yields a number of roots equal to the order of the matrix of the characteristic equations, Eq. VII.13 admits only one non-vanishing root, i. e., one value for the functional $J[\alpha]$. The reason is that all terms except those containing the two highest powers of $J[\alpha]$ cancel. This result is consistent with the fact that the non-homogeneous integral equation admits only one non-trivial solution. The value of $J[\alpha]$ obtained from Eq. VII.13 is given in ref. 1, p. 115, Eq. VI.12a.

The advantage of analyzing the antisymmetric and the symmetric components of the velocity distribution separately is that if M unknown coefficients are used in each of the two trial functions which describe the resultant velocity distribution $(\alpha_s + \alpha_a)$, two determinants of order M must be solved. If the velocity distribution is not split in this fashion, a determinant of order $2M$ must be solved to achieve a solution of comparable accuracy. This, of course, is more laborious.

It is shown in reference 1 that when h/a , the transducer wall thickness to radius ratio, is sufficiently small to make the quantity

$$\frac{h}{a}(1-\nu) - \left(\frac{h}{a}\right)^2 \nu \ll 1 \quad \text{in the case of magnetostrictive transducers}$$

$$\frac{h}{a}\left(1 - \frac{1}{\nu}\right) - \left(\frac{h}{a}\right)^2 \frac{1}{\nu} \ll 1 \quad \text{in the case of piezoelectric transducers} \quad (\text{VII.14})$$

the coefficients β_1 and β_0 can be set equal to unity. This in turn makes the Green's function combinations $\Gamma_{\frac{1}{2}}(z-z')$ and $\hat{\Gamma}_{\frac{1}{2}}(z-z')$ in Eqs. IV.11 equal. With this assumption, and making use of the fact that the functions $\Gamma_{\frac{1}{2}}(z-z')$ are symmetric in $(z-z')$ to invert the order of integration,* the functional in Eq. VII.2a can be written as

$$A[\alpha_{\frac{1}{2}}] = \int_{z_{j-L}}^{z_{j+L}} \left[\int_{z_{j+}}^{z_{j+L}} \alpha_{\frac{1}{2}}(z') \Gamma_{\frac{1}{2}}(z-z') dz' \right] dz \quad (\text{VII.15})$$

When $\alpha(z)$ satisfies the integral equation, Eq. VII.3 applies, and the functional $J[\alpha]$, Eq. VII.4, equals $-A[\alpha]$. If we now compare Eqs. VII.15 and IV.14, we see that $(Z_{jj})_{\alpha}$, i.e., the component of the self-impedance associated with the radial velocity distribution $(\alpha = \alpha_s + \alpha_a)$, is proportional to the sum of the roots, $J[\alpha_s]$ and $J[\alpha_a]$, of the characteristic equations, Eq. VII.13:

$$(Z_{jj})_{\alpha} = \text{imp}(2\pi a)^2 (J[\alpha_s] + J[\alpha_a]) \quad (\text{VII.16})$$

Thus for array elements whose ratio h/a is sufficiently small, the self-impedance of any element can be obtained directly from the characteristic equation without previously having to compute the undetermined coefficients in the trial functions. If the ratio h/a is too large for this approximation, the values of the functionals

*The expression "symmetric" means that z and z' can be interchanged, i.e., that $\Gamma(z-z') = \Gamma(z'-z)$. In Section IV, the term "symmetric" refers to the fact that changing z into $-z$ does not change the value of Γ_s . Γ_a is "antisymmetric" in z , because changing the sign of z alters the sign of Γ_a , but it is symmetric in $(z-z')$ because interchanging these two variables does not alter Γ_a .

$J[\alpha]$ must be substituted back into the corresponding set of M homogeneous equations, Eqs. VII.12, each of which will yield $(M-1)$ ratios of undetermined coefficients.

Finally, the value of one of these unknown coefficients, say x_1 , is obtained by substituting these ratios in the functional $A[\alpha]$ as given by Eq. VII.11a. As noted earlier, this functional equals $-J[\alpha]$, for the value of $\alpha(z)$ which satisfies the integral equation. Therefore, setting Eq. VII.11a equal to the value of $J[\alpha]$ obtained from Eq. VII.13, we can solve for the remaining undetermined coefficient. Thus, for trial functions involving these undetermined coefficients,

$$x_1 = \frac{-J[\alpha]}{a_1 + a_2(x_2/x_1) + a_3(x_3/x_1)} \quad (\text{VII.17})$$

An alternative procedure is to select the remaining undetermined coefficients so as to satisfy the original integral equation itself. Unless the functional dependence of the trial function, Eq. VII.8, on z is the correct one, this coefficient can not be selected so as to satisfy the integral equation over the whole region z_{r+} . It is advantageous to select the coefficient so as to satisfy the equation for a value of z associated with a relatively large value of $\alpha(z)$, i.e., a value of z which lies close to the active transducer element. In the case of a three-element array, and for the trial function assumed in Eq. VII.8, one might select x_3 so as to satisfy the integral equation at $z=L+b$. Previously, one would substitute in the set of homogeneous equations, Eqs. VII.12, the value of $J[\alpha]$ as obtained from Eq. VII.13. One can then solve for the ratios x_1/x_3 . The integral equation, Eq. IV.12, then yields

$$x_3 = \frac{-\int_{z_1-L}^{z_3+L} \Delta(L+b-z') dz'}{\frac{h}{2\pi a} + \int_L^{L+2b} \Gamma(L+b-z') dz' + \int_{L+2b}^{\infty} \Gamma(L+b-z') \left[\frac{x_1}{x_3} \frac{1}{(z')^3} + \frac{x_2}{x_3} \frac{1}{(z')^2} \right] \exp(ikz') dz'} \quad (\text{VII.18})$$

Once again, the subscripts "s" and "a" have been omitted in this equation.

Having thus determined the coefficients in terms of which the trial functions are expressed, the self- and mutual impedance correction factors, $(Z_{jj})_\alpha$ and $(Z_{jk})_\alpha$, are computed by substituting the trial functions in Eq. IV.14. The far field potentials can also be obtained, by using the expressions given in ref. 1, Sections VII and VIII.

It was mentioned in the introduction that the application of the variational principle to the array is less advantageous than its application to the single "squitter." The reason is precisely that, in contrast to the self-impedance, the mutual impedances cannot be obtained directly from the value of $J[\zeta]$ computed from Eq. VII.16, but require that Eqs. VII.12 be solved for the undetermined coefficients x_n . It is possible that a more sophisticated variational approach, whereby the mutual as well as the self-radiation impedances can be found directly from stationary functionals, can be evolved by formulating the array analysis as a multiple scattering problem. In this formulation the scattering cross sections of the array elements would be expressed in terms of stationary functionals constructed in accordance with the Levine-Schwinger variational formulation of diffraction problems. The radiation impedances would then be related to the scattering cross sections.

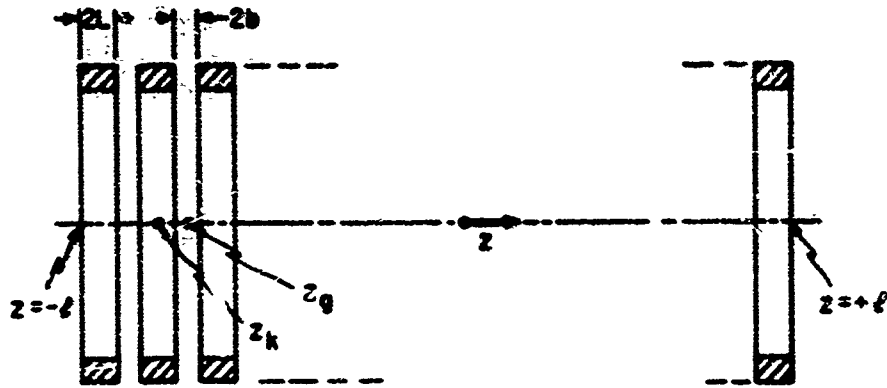
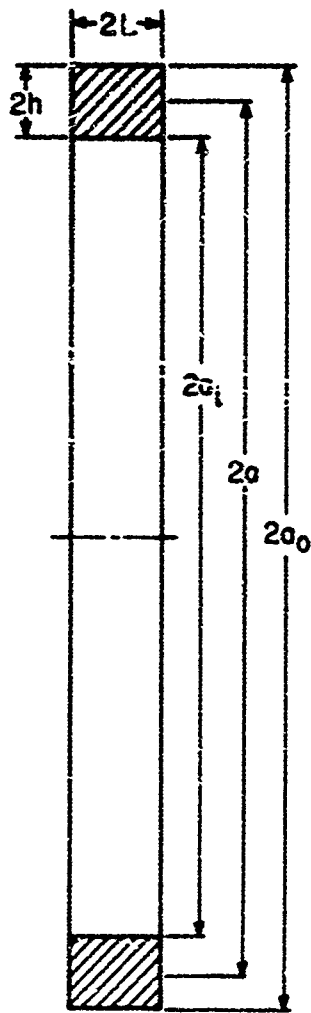

Fig. 1. FREE-FLOODING ARRAY OF SPACED RING TRANSDUCERS

Number N of Transducer Elements	Index Number		Location of Plane of Symmetry	
	of transducer elements, k	of gaps between elements, g	of transducer elements, z_k	of gaps between elements, z_g
Even	$-\frac{N}{2}, \dots, -1,$ $+1, \dots, \frac{N}{2}$	$-(\frac{N}{2}-1), \dots, -1,$ $0, +1, \dots, \frac{N}{2}-1$	$z_k = (2k-1)(L+b)$	$z_g = 2g(L+b)$
Odd	$-(N-1)/2, \dots,$ $-1, 0, +1, \dots,$ $+(N-1)/2$	$-(N-1)/2, \dots,$ $-1, +1, \dots,$ $(N-1)/2$	$z_k = 2k(L+b)$	$z_g = (2g-1)(L+b)$



Radial Velocity at Outer Radius a_0 : u_0
 Radial Velocity at Mean Radius a : U
 Radial Velocity at Inner Radius a_i : u_i

Fig. 2. GEOMETRY OF TRANSDUCER ELEMENT

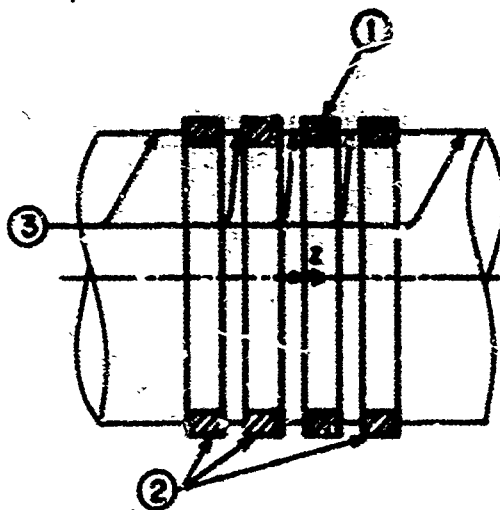

(a) Four-Element Array

- ① Active element: $u(z)=U$
- ② Inactive elements: $u(z)=0$
- ③ Unknown velocity: $u(z)=Ux(z)$

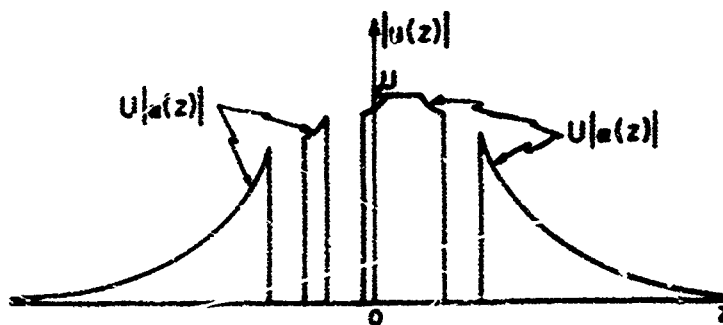

(b) Velocity Distribution on Cylindrical Surface $r=a$

Fig. 3. RADIAL VELOCITY DISTRIBUTION SCHEMATICALLY ILLUSTRATED FOR FOUR-ELEMENT ARRAY

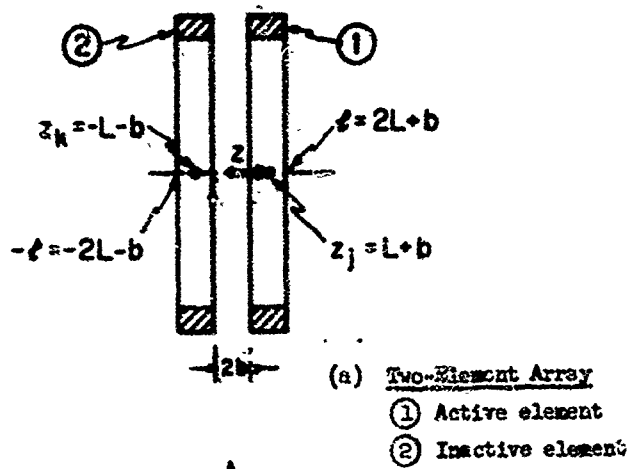

Resultant velocity distribution

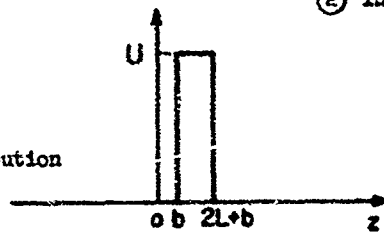

Symmetric components

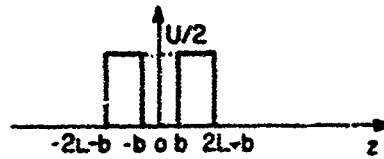

Antisymmetric components

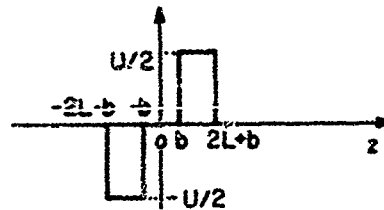

(b) Transducer Velocity Distribution

Fig. 4. SPLITTING OF VELOCITY DISTRIBUTION INTO SYMMETRIC (EVEN) AND ANTISYMMETRIC (ODD) COMPONENTS ILLUSTRATED FOR TWO ELEMENT-ARRAY

38

References

1. N. C. Junger, A Variational Solution of Solid and Free-Flooding Cylindrical Sound Radiators of Finite Length, CAA Rept. No. U-177-48, 1 March 1964.
2. D. H. Robey, "On the Radiation Impedance of an Array of Finite Cylinders," *J. Acoust. Soc. Am.* 27, 706 (1955).
3. J. E. Greenspan, "An Approximation to the Remainder of Robey's Reactive Impedance Integral," *J. Acoust. Soc. Am.* 33, 1428 (1961).
4. J. E. Greenspan and C. H. Sherman, "Mutual Impedance and Near Field Pressure for Pistons on a Cylinder," *J. Acoust. Soc. Am.* 36, 148 (1964).
5. D. T. Laird and H. Cohen, "Directionality Patterns for Acoustic Radiation from a Source on a Rigid Cylinder," *J. Acoust. Soc. Am.* 24, 46 (1952).
6. D. H. Robey, "On the Contribution of a Contained Viscous Liquid to the Acoustic Impedance of a Radially Vibrating Tube," *J. Acoust. Soc. Am.* 27, 22 (1955).
7. D. H. Robey, "On the Radiation Impedance of a Liquid-Filled Squirting Cylinder," *J. Acoust. Soc. Am.* 27, 711 (1955).
8. M. L. Baron, A. T. Matthews, and H. R. Bleich, Forced Vibrations of an Elastic Circular Cylindrical Body of Finite Length Submerged in an Acoustic Fluid, ONR Contract Nonr-3454(GO)PAM, Tech. Rept. No. 1, June 1962.
9. L. H. Chai and D. G. Schweikert, "Sound Radiation from an Arbitrary Body," *J. Acoust. Soc. Am.* 35, 1626 (1963).

DISTRIBUTION LIST

Chief of Naval Research
Department of the Navy
Washington 25, D. C.
Attn: Code 439 (2 copies)
Code 468 (2 copies)

Commanding Officer
Office of Naval Research
Branch Office
495 Summer Street
Boston, Mass. 02110

Commanding Officer
Office of Naval Research
Branch Office
John Greer Library Building
86 E. Randolph Street
Chicago 11, Illinois

Commanding Officer
Office of Naval Research
Branch Office
207 West 24th Street
New York 11, New York

Commanding Officer
Office of Naval Research
Branch Office
Navy #100, Fleet Post Office
New York, New York (5 copies)

Director
Naval Research Laboratory
Washington, D. C. 20390
Attn: Code 2000, Tech Info Of (6 copies)
Code 6200, Mechs Div.
Code 6250, Shock and Vibration
Code 6260, Structures
Code 5500, Sound Division

Defense Documentation Center (20 copies)
Cameron Station, Building #5
5010 Duke St., Alexandria, Va. 22314

Office of Technical Services
Department of Commerce
Washington 25, D. C.

Office of Naval Research
Department of the Navy
Washington 25, D. C.
Attn: Dr. F. J. Veyl

Applied Physics Laboratory
Johns Hopkins University
3621 Georgia Avenue
Silver Spring, Maryland
Attn: Dr. W. H. Avery

U.S. Naval Electronics Laboratory
San Diego 52, California
Attn: Dr. R. J. Christensen

Chief, Bureau of Ships
Department of the Navy
Washington 25, D. C.
Attn: Capt. W. H. Cross, Code 403

Woods Hole Oceanographic Institute
Woods Hole, Massachusetts
Attn: Dr. P. N. Fye

Chief, Bureau of Naval Weapons
Department of the Navy
Washington 25, D. C.
Attn: Dr. E. S. Lamar, CR-12

U.S. Naval Ordnance Test Station
China Lake, California
Attn: Dr. T. Phipps

Office of Naval Research
Department of the Navy
Washington 25, D. C.
Attn: Capt. W. T. Sawyer, Code 406

Chief, Bureau of Ships
Department of the Navy
Washington 25, D. C.
Attn: Dr. G. Sponsler, Code 315

Director, Naval Research Laboratory
Department of the Navy
Washington 25, D. C.
Attn: Mr. P. Waterman, Code 5360

Missile and Space Division
Lockheed Aircraft Corporation
Palo Alto, California
Attn: Dr. W. F. Whitmore

Special Projects Office
(SP-114)
Bureau of Naval Weapons
Department of the Navy
Washington 25, D. C.
Attn: LCDR H. H. Yerbury
(Executive Secretary)

Special Projects Office
(SP-1142)
Bureau of Naval Weapons
Department of the Navy
Washington 25, D. C. (3 copies)

Director of Defense Research and Eng.
The Pentagon
Washington 25, D. C.
Attn: Technical Library

Chief, Defense Atomic Support Agency
The Pentagon
Washington 25, D. C.
Attn: Tech. Info. Division
Blast and Shock Branch

Office of the Secretary of the Army
The Pentagon
Washington 25, D. C.
Attn: Army Library

Chief of Staff
Department of the Army
Washington 25, D. C.
Attn: R and D Division

Office of the Chief of Engineers
Department of the Army
Washington 25, D. C.
Attn: ENG-ML Lib. Br., Adm. Ser
ENG-MB Special Engr. Br., and DIV.

Commanding Officer
Engineer Research Development Laboratory
Fort Belvoir, Virginia

Commanding Officer
Watertown Arsenal
Watertown, Mass. 02172
Attn: Laboratory Division

Commanding Officer
Frankford Arsenal
E. Jansburg Station
Philadelphia 37, Pennsylvania
Attn: Laboratory Division

U.S. Army Research Office
2127 Myrtle Drive
Duke Station
Durham, North Carolina
Attn: Div. of Engrg. Sciences

Chief of Naval Operations
Department of the Navy
Washington 25, D. C.
Attn: Op OF

Commandant, Marine Corps
Headquarters, U. S. Marine Corps
Washington 25, D. C.

Commanding Officer
USNWCN
Kirtland Air Force Base
Albuquerque, New Mexico
Attn: Code 20 (Dr. J. E. Brennan)

DIME Underwater Explosion Res. Div.
Norfolk Naval Shipyard
Portsmouth, Virginia
Attn: Mr. D. S. Cohen

Chief, Bureau of Ships
Department of the Navy
Washington 25, D. C.
Attn: Code 335, Tech. Info. Div.
Code 345, Mr. F. Vane

~~Code 420~~
Code 421
~~Code 423~~
Code 425
Code 440
Code 442
Code 443
Code 689, Mr. I. Cook
Code 1500

Chief, Bureau of Naval Weapons
Department of the Navy
Washington 25, D. C.
Attn: RAAD, Airframe Design
DLI-3, Tech. Library
R-12, Chief Scientist
RNSA, MI and Airframe Br.
NI, ASW Division
RRNS, Research Br.

Special Projects Office
Bureau of Naval Weapons
Department of the Navy
Washington 25, D. C.
Attn: Code SP-001, Chief Scientist
Code SP-20, Tech. Director

Chief, Bureau of Yards and Docks
Department of the Navy
Washington 25, D. C.
Attn: Code 70, Research
Code 820 Tech. Library

Commanding Officer and Director
David Taylor Model Basin
Washington, D. C. 20007
Attn: Code 108, Mr. R. T. McGoldrick
Code 108B, Dr. M. Strasberg
Code 140, Tech. Info. Div.
Code 238, Dr. P. Chalkheimer
Code 563, Mr. A. O. Sykes
Code 700, Dr. A. E. Keil
Code 720, Mr. E. E. Johnson
Code 731, Mr. J. G. Pulos
Code 740, Dr. W. J. Sette
Code 760, Mr. E. Kocson
Code 761, Dr. E. Buchman
Code 771, Dr. R. Liebowitz

Commanding Officer and Director
U.S. Navy Underwater Sound Laboratory
Fort Trumbull
New London, Connecticut

Director
National Bureau of Standards
Washington 25, D. C.
Attn: Division of Mechanics

National Aeronautics and Space Adm.
1512 K. Street, N. W.
Washington 25, D. C.
Attn: Chief, Div. of Research
Information

Director
National Aeronautics and Space Adm
Langley Research Center
Langley Field, Virginia
Attn: Structures Division

Dr. M. L. Baron
Paul Weidinger, Consulting Engineer
770 Lexington Avenue
New York 21, New York

Professor H. H. Bleich
Department of Civil Engineering
Columbia University
618 Mudd Building
New York 27, New York

Professor B. A. Boley
Department of Civil Engineering
Columbia University
618 Mudd Building
New York 27, New York

Professor Nicholas J. Hoff
Dept. of Aeronautical Engineering
Stanford University
Stanford, California

Dr. C. W. Horton
Defense Research Laboratory
University of Texas
Austin 12, Texas

Dr. M. A. Brull
Engineering Mechanics Division
University of Pennsylvania
Philadelphia 4, Pennsylvania

Dr. F. DiMaggio
Dept. of Civil Engineering
Columbia University
618 Mudd Building
New York 27, New York

Professor D. C. Drucker
Division of Engineering
Brown University
Providence 12, Rhode Island

Dr. Ira Dyer
Boit Heranek and Newman, Inc.
50 Moulton Street
Cambridge, Massachusetts 02138

Professor A. C. Eringen
Dept. of Aeronautical Engineering
Purdue University
Lafayette, Indiana

Dr. Martin Goldberg
Special Projects, Applied Mechanics
Grumman Aircraft Engineering Corp.
Bethpage, Long Island, New York

Professor J. M. Goodier
Department of Mechanical Engineering
Stanford University
Stanford, California

Dr. Josh E. Greenspan
J G Engineering Research Assoc.
3709 Callaway Avenue
Baltimore 15, Maryland

Professor Philip G. Hodge
Armour Research Foundation
10 West 35th Street
Chicago, Illinois

Professor W. Prager, Chairman
Physical Sciences Council
Brown University
Providence 12, Rhode Island

Professor Joseph Kumpner
Dept. of Aeronautical Engineering
and Applied Mechanics
Polytechnic Institute of Brooklyn
333 Jay Street
Brooklyn 1, New York

Professor J. M. Klosner
Dept. of Aeronautical Engineering
and Applied Mechanics
Polytechnic Institute of Brooklyn
333 Jay Street
Brooklyn 1, New York

Professor E. H. Lee
Brown University
Division of Applied Mathematics
Providence 12, Rhode Island

Professor R. D. Mindlin
Dept. of Civil Engineering
Columbia University
618 Mudd Building
New York 27, New York

Commander
U.S. Naval Ordnance Laboratory
White Oak, Maryland
Attn: SA, Technical Library
D, Technical Director
CF, Underwater Weapons
ES, Acoustics Division

Commanding Officer
U.S. Naval Mine Defense Laboratory
Panama City, Florida

Commander
U.S. Naval Air Development Center
Johnstown, Pennsylvania

Director
U.S. Navy Underwater Sound Ref. Lab.
Office of Naval Research
P. O. Box 6337
Orlando, Florida

Commanding Officer and Director
U.S. Navy Electronics Laboratory
San Diego 52, California
Attn: Mr. George S. Coleman, Code 2323

Commander
Portsmouth Naval Shipyard
Portsmouth, New Hampshire

Commander
Naval Station
Vallejo, California

Director, Materials Laboratory
New York Naval Shipyard
Brooklyn, New York 11251

Officer-in-Charge
Naval Civil Engineering Research
and Evaluation Laboratory
U.S. Naval Construction Battalion Center
Fort Huachuca, California

Director
Naval Air Experiment Station
Naval Air Material Center
Naval Base, Philadelphia 12, Penna.
Attn: Structures Laboratory

Officer-in-Charge
David Taylor Model Basin
Underwater Explosion Research Division
Norfolk Naval Shipyard
Portsmouth, Virginia
Attn: Dr. H. M. Schauer

Commander
U. S. Naval Proving Ground
Dahlgren, Virginia

Supervisor of Shipbuilding, USN and
Naval Inspector of Ordnance
General Dynamics Corporation
Electric Boat Division
Groton, Connecticut 06340

Commander
Naval Ordnance Test Station, China Lake,
Attn: Physics Division California
Mechanics Division

Commanding Officer
Naval Ordnance Test Station
Underwater Ordnance Division
3202 E. Foothill Boulevard
Pasadena 8, California

Commanding Officer and Director
U.S. Naval Engineering Experiment Sta.
Annapolis, Maryland

Superintendent
U.S. Naval Postgraduate School
Monterey, California

Commander
Air Material Command
Wright-Patterson Air Force Base
Dayton, Ohio
Attn: MCRK-B
Structures Division

Commander, WADD
Wright-Patterson Air Force Base
Ohio
Attn: WAFD
WAFMS
WAFMD

Director of Intelligence
Headquarters, U.S. Air Force
Washington 25, D. C.
Attn: P. V. Branch (Air Targets Div)

Commander
Air Force Office of Scientific Res.
Washington 25, D. C.
Attn: Mechanics Division

U.S. Atomic Energy Commission
Washington 25, D. C.
Attn: Director of Research

Professor P. M. Naghdi
University of California
College of Engineering
Berkeley, California 04-0371

Professor N. M. Newmark, Head
Department of Civil Engineering
University of Illinois
Urbana, Illinois

Professor F. Pohle
Department of Mathematics
Adelphi College
Garden City, New York

Woods Hole Oceanographic Institution
Woods Hole, Massachusetts

Professor F. V. Romano
Dept. of Aeronautical Engineering
and Applied Mechanics
Polytechnic Institute of Brooklyn
333 Jay Street
Brooklyn 1, New York

Professor E. Reiss
Institute of Mathematical Sciences
New York University
25 Waverly Place
New York 3, New York

Dean V. L. Salerno
College of Science and Engineering
Fairleigh Dickinson University
Raritan, New Jersey

Professor A. S. Veletsos
Department of Civil Engineering
University of Illinois
Urbana, Illinois

Brown University
Research Analysis Group
Providence, Rhode Island

Hydrospace Research Corporation
1749 Rockville Pike
Rockville, Maryland

Hudson Laboratories
Columbia University
145 Palisades Street
Dobbs Ferry, New York

Lamont Geological Observatory
Columbia University
Torre Cliffs
Palisades, New York

Ordnance Research Laboratory
University of Pennsylvania
P. O. Box 30, State College, Pa. 16801

Dr. Richard Waterhouse
American University
Physics Department
Washington 16, D. C.

Mr. Stan Lemon
Chesapeake Instrument Corporation
Shadyside, Maryland

Dr. M. M. Backus
Texas Instruments Incorporated
100 Exchange Park North
Dallas, Texas

Dr. H. Basin
Hughes Aircraft Company
P. O. Box 2097
Fullerton, California

Mr. John Mahoney
ONR Resident Representative
Harvard University
473 Broadway
Cambridge, Mass. 02138

Naval Ordnance Laboratory
White Oak
Silver Spring, Maryland
Attn: Dr. D. F. Bleil

<p>1. Sound transducer arrays - radiation loading</p> <p>2. Physics - acoustics</p> <p>3. M. C. Junger</p>	<p>Cambridge Acoustical Associates, Inc., Cambridge, Massachusetts. Report U-176-40 NATURAL AND SELF-RADIATING IMPEDANCES IN AN ARRAY OF PRESS-FLUIDS, CANTAL, SPACED RING TRANSDUCERS, by M. C. Junger. (Tech. Rpt. No. 157-21, Contract Nonr-3779(GO) UNCLASSIFIED)</p> <p>Expressions are derived for the natural and self-radiation impedances between the elements in an array of cantal, press-fluids, radially spaced ring transducers or "equivalent". The radiation impedances are expressed as the sum of two components: (1) the impedance associated with the wave associated with fluid flow through the gaps between elements and around the array as a whole. This fluid flow is defined by an integral equation. This equation is solved by four alternative techniques: (1) perturbation iteration, finite-difference, and variational. This study is a sequel to a report (DA 0-177-40) dealing with single cylindrical sources in the form of "equivalent" and solid cylinders.</p>	<p>1. Sound transducer arrays - radiation loading</p> <p>2. Physics - acoustics</p> <p>3. M. C. Junger</p>	<p>Cambridge Acoustical Associates, Inc., Cambridge, Massachusetts. Report U-176-40 NATURAL AND SELF-RADIATING IMPEDANCES IN AN ARRAY OF PRESS-FLUIDS, CANTAL, SPACED RING TRANSDUCERS, by M. C. Junger. (Tech. Rpt. No. 157-21, Contract Nonr-3779(GO) UNCLASSIFIED)</p> <p>Expressions are derived for the natural and self-radiation impedances between the elements in an array of cantal, press-fluids, radially spaced ring transducers or "equivalent". The radiation impedances are expressed as the sum of two components: (1) the impedance associated with the wave associated with fluid flow through the gaps between elements and around the array as a whole. This fluid flow is defined by an integral equation. This equation is solved by four alternative techniques: (1) perturbation iteration, finite-difference, and variational. This study is a sequel to a report (DA 0-177-40) dealing with single cylindrical sources in the form of "equivalent" and solid cylinders.</p>
<p>1. Sound transducer arrays - radiation loading</p> <p>2. Physics - acoustics</p> <p>3. M. C. Junger</p>	<p>Cambridge Acoustical Associates, Inc., Cambridge, Massachusetts. Report U-176-40 NATURAL AND SELF-RADIATING IMPEDANCES IN AN ARRAY OF PRESS-FLUIDS, CANTAL, SPACED RING TRANSDUCERS, by M. C. Junger. (Tech. Rpt. No. 157-21, Contract Nonr-3779(GO) UNCLASSIFIED)</p> <p>Expressions are derived for the natural and self-radiation impedances between the elements in an array of cantal, press-fluids, radially spaced ring transducers or "equivalent". The radiation impedances are expressed as the sum of two components: (1) the impedance associated with the wave associated with fluid flow through the gaps between elements and around the array as a whole. This fluid flow is defined by an integral equation. This equation is solved by four alternative techniques: (1) perturbation iteration, finite-difference, and variational. This study is a sequel to a report (DA 0-177-40) dealing with single cylindrical sources in the form of "equivalent" and solid cylinders.</p>	<p>1. Sound transducer arrays - radiation loading</p> <p>2. Physics - acoustics</p> <p>3. M. C. Junger</p>	<p>Cambridge Acoustical Associates, Inc., Cambridge, Massachusetts. Report U-176-40 NATURAL AND SELF-RADIATING IMPEDANCES IN AN ARRAY OF PRESS-FLUIDS, CANTAL, SPACED RING TRANSDUCERS, by M. C. Junger. (Tech. Rpt. No. 157-21, Contract Nonr-3779(GO) UNCLASSIFIED)</p> <p>Expressions are derived for the natural and self-radiation impedances between the elements in an array of cantal, press-fluids, radially spaced ring transducers or "equivalent". The radiation impedances are expressed as the sum of two components: (1) the impedance associated with the wave associated with fluid flow through the gaps between elements and around the array as a whole. This fluid flow is defined by an integral equation. This equation is solved by four alternative techniques: (1) perturbation iteration, finite-difference, and variational. This study is a sequel to a report (DA 0-177-40) dealing with single cylindrical sources in the form of "equivalent" and solid cylinders.</p>