

**UNCLASSIFIED**

**AD**

**435033**

**DEFENSE DOCUMENTATION CENTER**

**FOR**

**SCIENTIFIC AND TECHNICAL INFORMATION**

**CAMERON STATION, ALEXANDRIA, VIRGINIA**



**UNCLASSIFIED**

NOTICE: When government or other drawings, specifications or other data are used for any purpose other than in connection with a definitely related government procurement operation, the U. S. Government thereby incurs no responsibility, nor any obligation whatsoever; and the fact that the Government may have formulated, furnished, or in any way supplied the said drawings, specifications, or other data is not to be regarded by implication or otherwise as in any manner licensing the holder or any other person or corporation, or conveying any rights or permission to manufacture, use or sell any patented invention that may in any way be related thereto.

# 435033

435033

February 1964

SPECTRAL FLASH LAMP,  
SEMI-ANNUAL TECHNICAL REPORT,

by H. R. Koenig and W. E. Hill,

Work Performed By

Advanced Technology Laboratories  
GENERAL ELECTRIC COMPANY  
Schenectady, New York

Project Code No. 3730

Contract No. Nonr 4121(00)

Order No. 306-62

Contract Period: 1 April 63 - 31 March 64  
Amount of Contract: \$108,340

APR 15 1964

This research is a part of Project DEFENDER under the joint sponsorship of the Advanced Research Projects Agency, the Office of Naval Research and the Department of Defense.

AI

NO. OTS

AD NO.   
 DDC FILE COPY

(5) 354000

(9)   
 (10)   
 (6)

(11)

(16)   
 (15)

sal

NON A

## TABLE OF CONTENTS

INTRODUCTION	1
METAL IODIDE LAMPS	2
POWER SUPPLY	2
MEASUREMENT OF IRRADIANCE	3
LAMP TEST PROCEDURE	4
IRRADIANCE OF XENON AND DOPED XENON LAMPS	5
DISCHARGE CHAMBER TESTS WITH NEON	8
IRRADIANCE OF NEON DISCHARGES	9
FIGURE 1. Metal Iodide Test Lamp and High Pressure Sodium Lamp	
FIGURE 2. Schematic of Power Supply	
FIGURE 3. Capacitor Bank	
FIGURE 4. Capacitor Bank, Showing Terminals of the Six Sections	
FIGURE 5. Ignitron and Other Circuit Components	
FIGURE 6. Control Chassis for Charging Supply and Switching	
FIGURE 7. Schematic of Irradiance Measurement	
FIGURE 8. Schematic for one Grating of Spectrophotometer	
FIGURE 9. Photomultipliers on Spectrophotometer	
FIGURE 10. Peak Irradiance of E.G.G. FX-47 Xenon Lamp	
FIGURE 11. Peak Irradiance of Lamp Containing 100 Torr Xenon and Excess Gallium and Thallium Iodides	
FIGURE 12. Sample Scope Traces	
FIGURE 13. Peak Irradiance of Lamp Containing 50 Torr Xenon and Excess Gallium and Thallium Iodides	
FIGURE 14. Sample Scope Traces	

FIGURE 15. Peak Irradiance of Lamp Containing 25 Torr Xe, Excess Gallium and Thallium Iodides

FIGURE 16. Discharge Chamber Mounted in Test Stand

FIGURE 17. Peak Irradiance of Lamps Filled with Neon at 50 Torr, 200 Torr, and 800 Torr

FIGURE 18. Peak Irradiance of a Lamp Filled with 400 Torr Neon

SPECTRAL FLASH LAMP  
SEMI-ANNUAL TECHNICAL REPORT

H. R. Koenig and W. E. Hill

INTRODUCTION

Investigations have been centered primarily around the enhancement of spectral irradiance at high power through doping with metal iodides. Initial work by General Electric with doped xenon in small diameter lamps gave encouraging results. Present investigations at high power are being carried out in lamps of 0.5 inch inside diameter.

Results of spectral irradiance measurements in doped xenon lamps of 0.5 inch inside diameter have shown significant spectral enhancement at loadings nominally used for one to two millisecond flashes, where discharge temperatures reach 10,000°K. At loadings appreciably greater than this, no significant enhancement has been obtained.

Irradiance measurements on metal iodide lamps containing xenon at low pressure and flashed at low loadings do not show improvement over xenon lamps. Further tests at higher loading are being carried out.

We are now conducting tests with neon in a quartz discharge chamber of 0.5 inch inside diameter. We have been able to obtain high temperatures with neon. Transparency is relatively high in most of the visible and near ultraviolet. The discharge chamber was flashed many times at 150 microseconds with spectral irradiance at 6100 Å equal to that of a 20,000°K black body. Spectral irradiances as high as that of a 30,000°K black body were obtained with 50 microsecond flashes.

## METAL IODIDE LAMPS

The metal iodide lamps being used and their processing were described in previous quarterly reports. The lower lamp shown in Figure 1 was used to obtain data. The seal to quartz is made at the edge of a molybdenum foil cup. The lead is 150 mil tungsten.

After baking out at  $1000^{\circ}\text{C}$ , the lamps were filled with approximately equal quantities by atomic number of gallium and thallium, and one iodine for each metal atom. The amount of metal iodide put in the lamp was more than the amount needed for saturation of vapor pressure in testing.

## POWER SUPPLY

A circuit schematic for the power supply is shown in Figure 2. The lamps were ignited by applying a high voltage to the anode of the lamp, switching the 33 kilovolt capacitor with the thyatron. The high current circuit was switched with a delay from the initiating pulse. The pre-ionizing current could be left to flow for periods ranging from 50 to 1000 microseconds before the high current pulse was applied.

Figure 3 is a photograph of the capacitor bank, having a capacity of 135 kilojoules. Figure 4 shows the terminals of the six sections, 22.5 kilojoules each at 5 kV. These sections may be seriesed and paralleled in any desired way, or used independently.

Figure 5 shows the ignitron in the high current circuit. Twelve parallel coaxial cables are used to connect the bank, switch, and lamp. The total circuit resistance is approximately 10 milliohms. Chokes used in the circuit are also of low resistance. Figure 6 shows the control chasses for one of the charging supplies and for the switching.

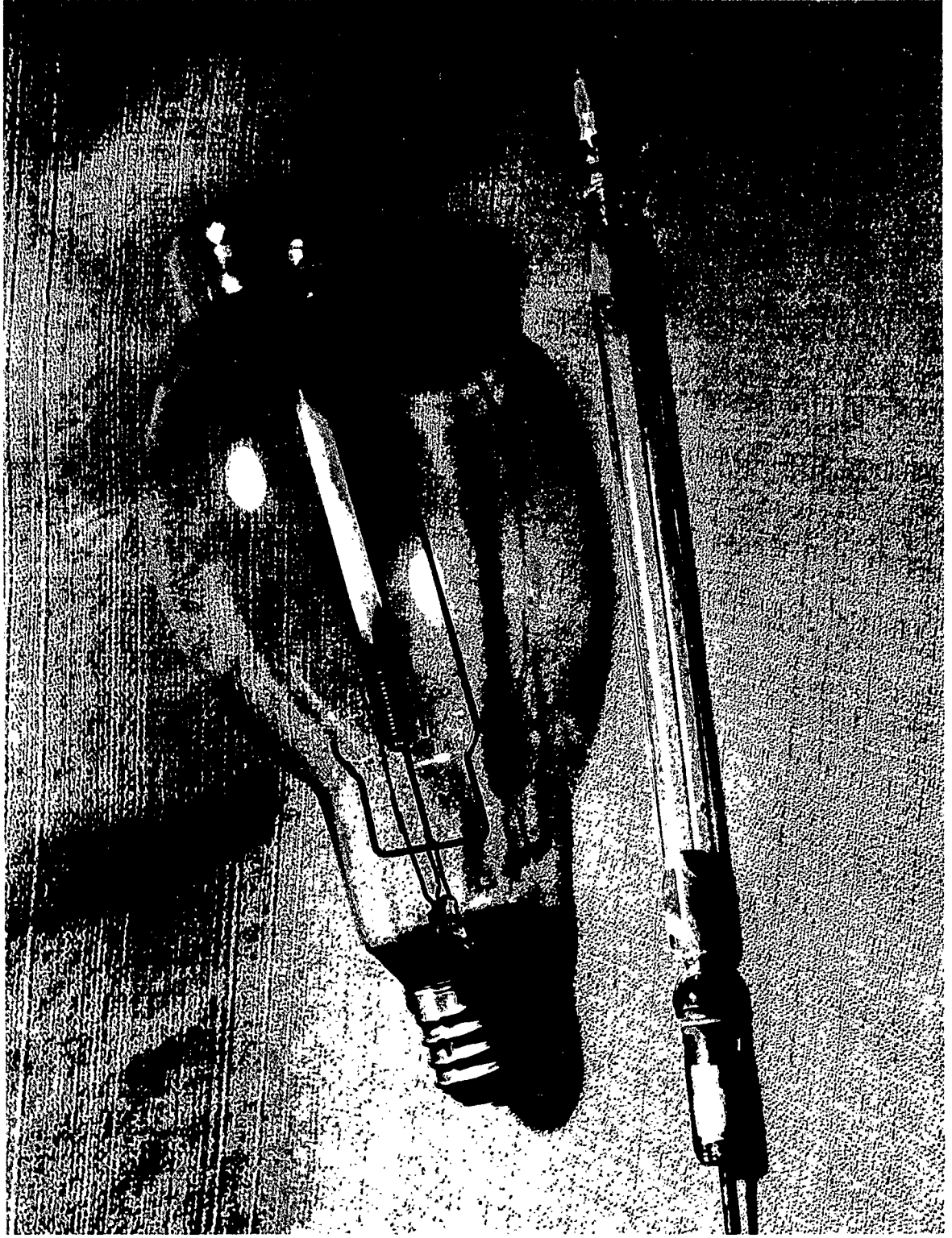
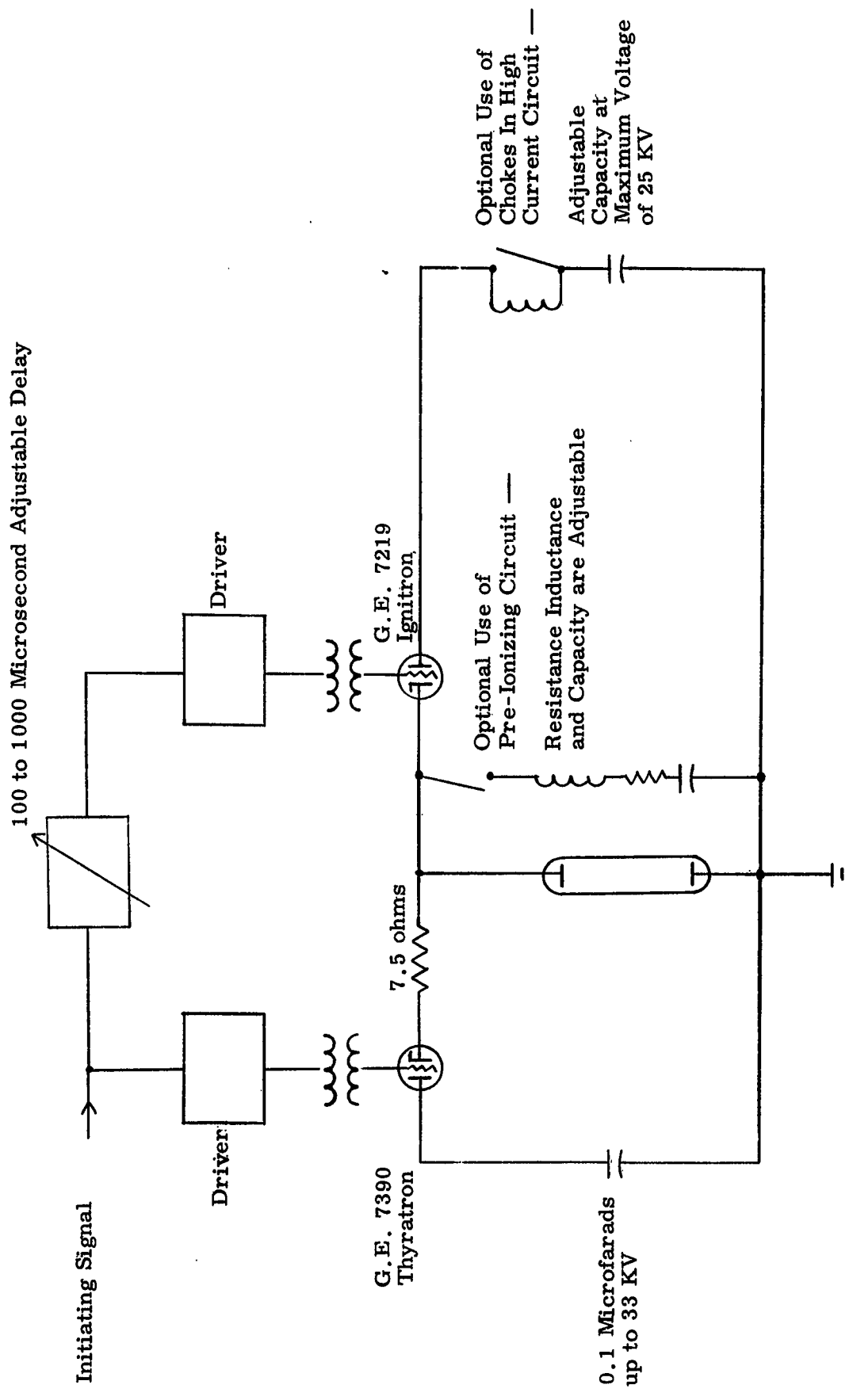

Figure 1. Metal Iodide Test Lamp (Lower) and High Pressure Sodium Lamp (Upper).



SCHMATIC OF POWER SUPPLY  
 TOTAL AVAILABLE ENERGY IS 135 KILOJOULES

FIGURE 2

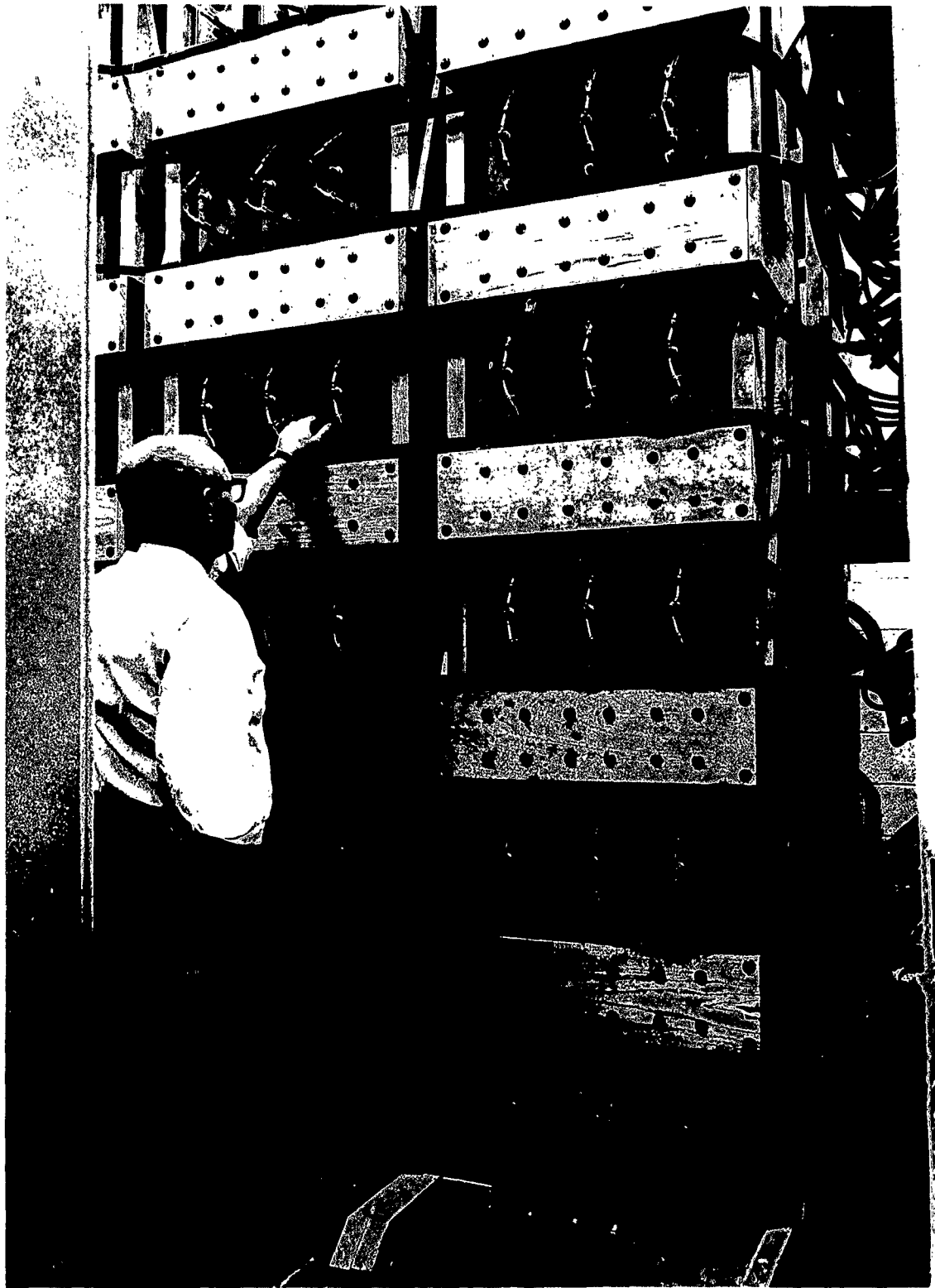

Figure 3. Capacitor Bank.

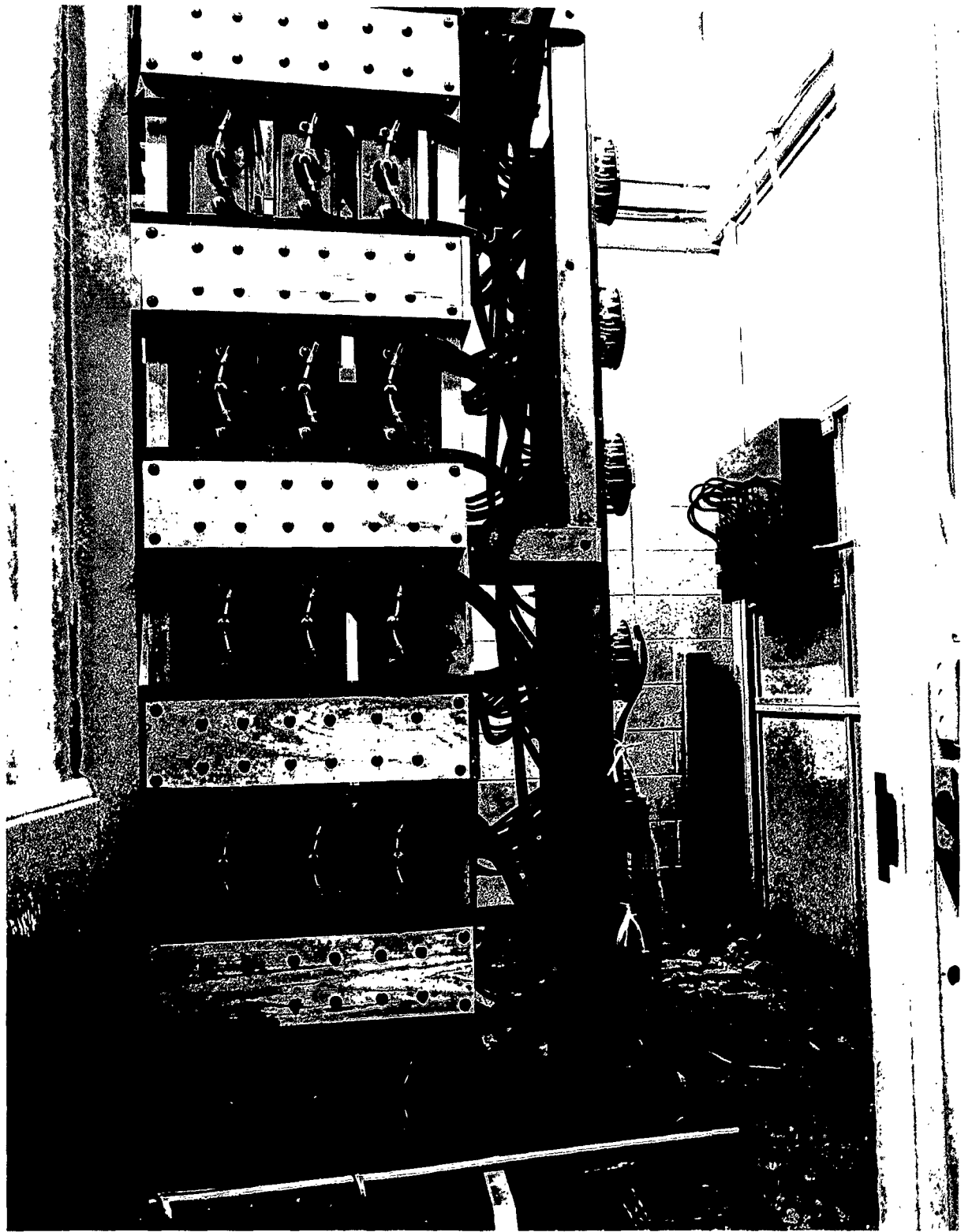

Figure 4. Capacitor Bank, Showing Terminals of the Six Sections.

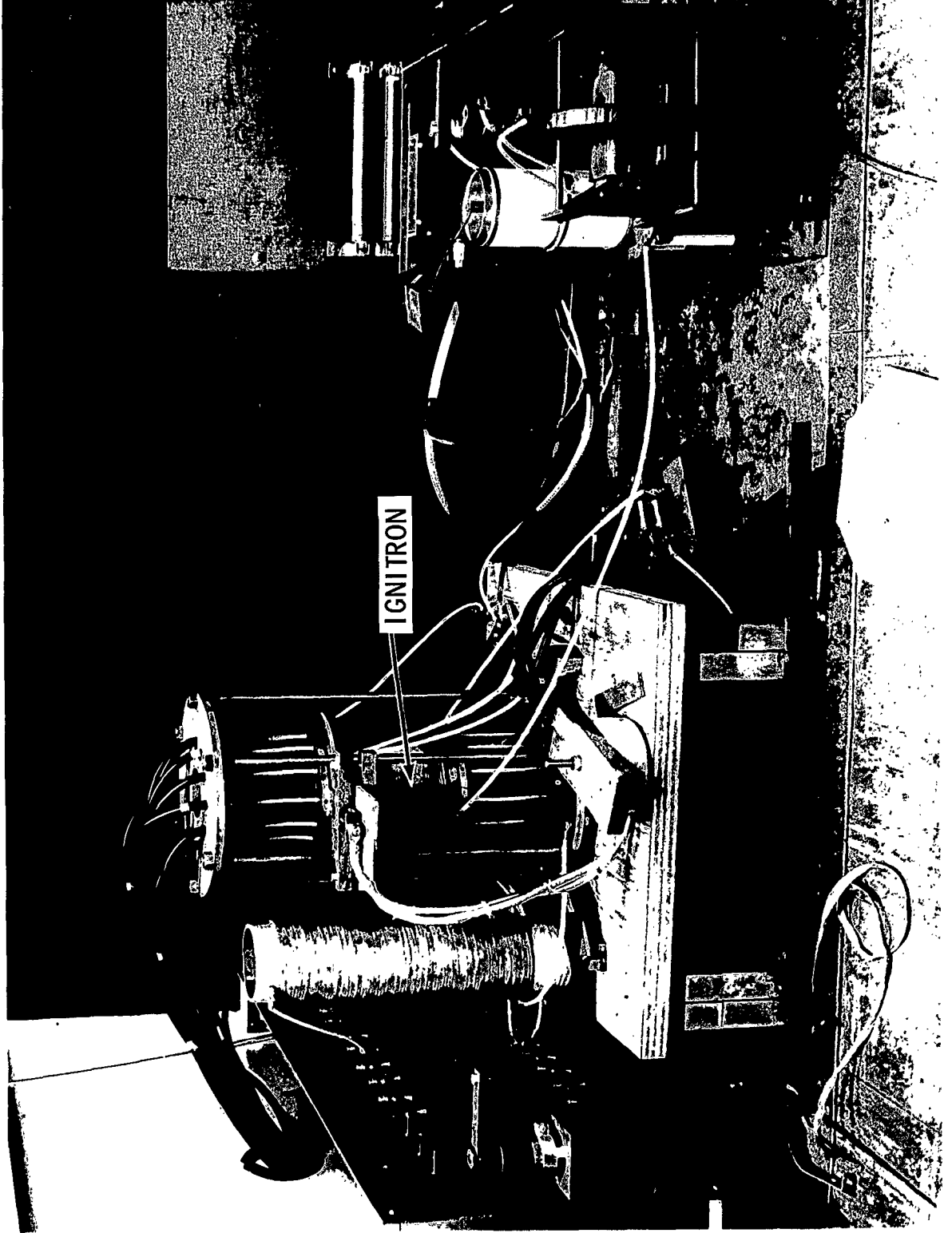

Figure 5. Ignitron and Other Circuit Components.



Figure 6. Control Chassis for Charging Supply and Switching.

## MEASUREMENT OF IRRADIANCE

Figure 7 is a schematic depicting the irradiance measurement. The lamp in the experiment room illuminates a reflecting surface of magnesium carbonate. The reflecting surface fills the field of view of the spectrophotometer. A General Electric 1000-1 tungsten iodine lamp calibrated by General Electric Large Lamp Department is being used for calibrating the spectrophotometer. Long pass filters are used for filtering second order light. Screens are sometimes used to obtain additional attenuation of light in flash operation.

Photomultipliers are used with multiple exit slits to read out from eight points in the spectrum simultaneously. The high sensitivity of photomultipliers is required because of the low optical efficiency of the irradiance measuring system.

Figure 8 shows a schematic of the recording using the short wavelength grating of the spectrophotometer. Photomultipliers are mounted directly behind the exit slits of the short wavelength grating. Light pipes are used between the exit slits on the long wavelength grating and the photomultipliers. Capacitors were put across the dynode resistors so that high photomultiplier currents, of the order of a milliamperere, can be drawn in a pulse. Figure 9 is a photograph of the exit slit end of the photometer with the photomultipliers.

The photomultiplier load resistors are in cable "T's" so that they are easily changed by changing "T's". Five megohms is being used with the calibrating source and a voltmeter is used to measure the voltage. Five kilohms is being used in flash lamp testing, giving approximately one microsecond time constant for recording irradiance with the oscilloscopes.

The exit slit width for the short wavelength grating is 7 millimeters ( $28 \text{ \AA}$ ) and the slits are spaced 35 millimeters ( $140 \text{ \AA}$ ) apart, or five exit slit widths

FIGURE 7  
SCHEMATIC OF IRRADIANCE MEASUREMENT

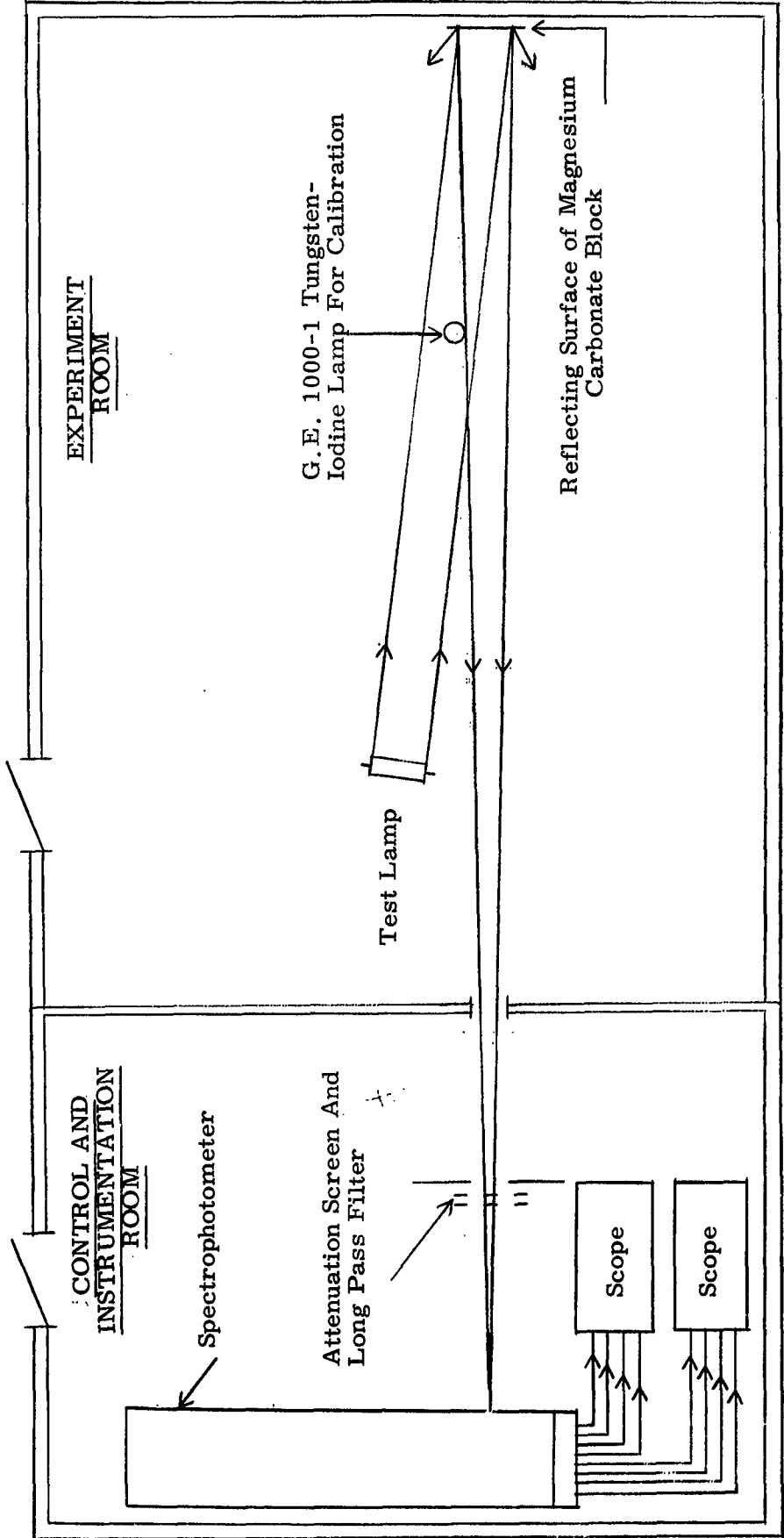

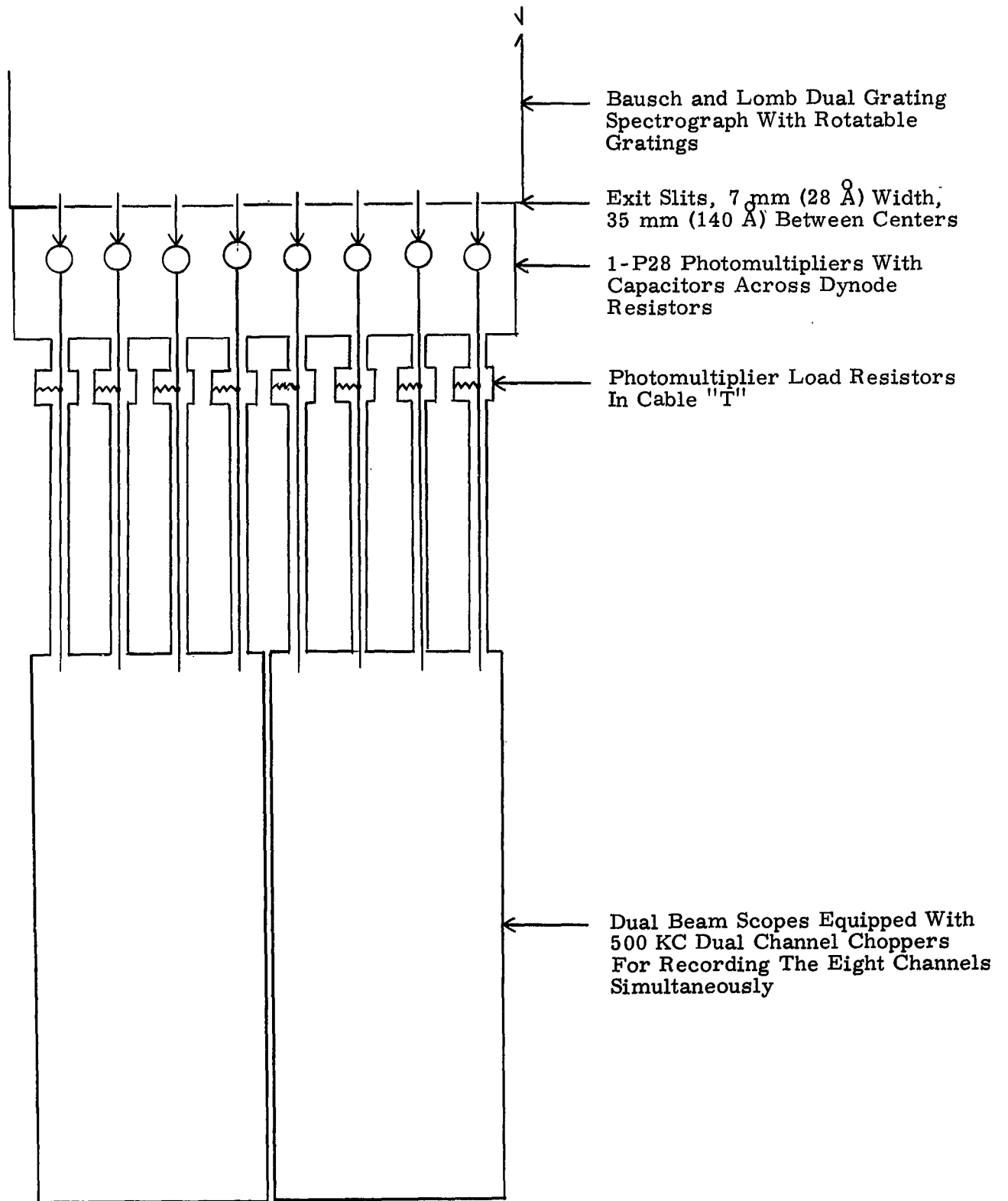

SCHMATIC FOR ONE GRATING OF SPECTROPHOTOMETER

FIGURE 8



Figure 9. Photomultipliers on Spectrophotometer.

apart. The exit slit width for the long wavelength grating is 3.5 millimeters ( $28 \text{ \AA}$ ) and the slits are spaced 17.5 millimeters ( $140 \text{ \AA}$ ) apart. The entrance slit width being used is one millimeter.

The large difference in irradiance between the calibrating lamp and the test lamps is accommodated by a ratio of 1000:1 in load resistors, a ratio of 1:3 in distance between lamp and reflecting surface, and as much as  $1:10^3$  on the load resistor voltage.

All irradiance measurements were made perpendicular to the lamp axis through the center of the lamp, and at a distance of three meters. All lamps were of 0.5 inch inside diameter and six inches electrode spacing. Average emittance of the test lamps in milliwatts per ( $28 \text{ \AA cm}^2 \text{ sterad}$ ) can be obtained by multiplying irradiance at three meters, milliwatts per ( $28 \text{ \AA cm}^2$ ), by  $4.64 \times 10^3$ .

#### LAMP TEST PROCEDURE

For the data obtained here, the lamps were placed in a quartz jacket in which a dry nitrogen atmosphere was maintained, and the jacket with lamp was put in an oven for heating to the desired temperature. Large openings were cut on opposite sides of the oven for irradiance measurements. These openings were cut so that light from the lamp and reflected light from the quartz jacket was included in the irradiance measurement, but light reflected from oven surfaces was not.

We have tried in all tests to keep the condensed vapors in back of the electrodes and out of the section of discharge chamber between the electrodes. When condensate appeared between the electrodes in appreciable quantity, the irradiance measurements were generally not repeatable. The best control of condensed vapors

was obtained by flowing cool nitrogen at a low rate onto the lamps behind one electrode, where the condensate then collected.

A hairpin shunt was used for current measurements and a Tecktronix 1000:1 compensated voltage probe was used for lamp voltage measurement.

Plots were made of peak irradiance against wavelength, and curves of black body irradiance drawn for comparison purposes. Irradiance was calculated for a black body cylinder having the dimensions of the flash lamp discharge, 0.5 inch diameter and 6 inches long. Peak current and voltage-at-peak-current are given for each curve. The product, peak current multiplied by voltage-at-peak-current, is probably a fair approximation of the peak power dissipation of the lamp.

## IRRADIANCE OF XENON AND DOPED XENON LAMPS

### Xenon Lamp

An E.G.G. FX-47 was chosen for comparison of irradiances because it is a popular flash lamp having dimensions approximately equal to the dimensions of the flash lamps used in the tests to be described. The high current circuit was used without a choke, and the pre-ionizing circuit gave approximately 1000 amperes for 0.7 milliseconds before the high current circuit was switched. The high current pulse was shorter than 80 microseconds. Figure 10 shows the results of the irradiance measurements. Peak current for the lower curve is 4500 amperes, an appropriate loading for flashes of the order of a millisecond duration. In the 3200 Å to 6200 Å band, peak irradiance is approximately at the level of a black body of 10,000°K to 11,000°K.

Peak current for the upper curve is 11,200 amperes, an appropriate loading for pulses of the order of 100 microseconds. At this loading, measured lamp irradiance in the 3200 Å to 6200 Å band is approximately at the level of a black body of 14,000°K to 16,000°K.

Figure 10

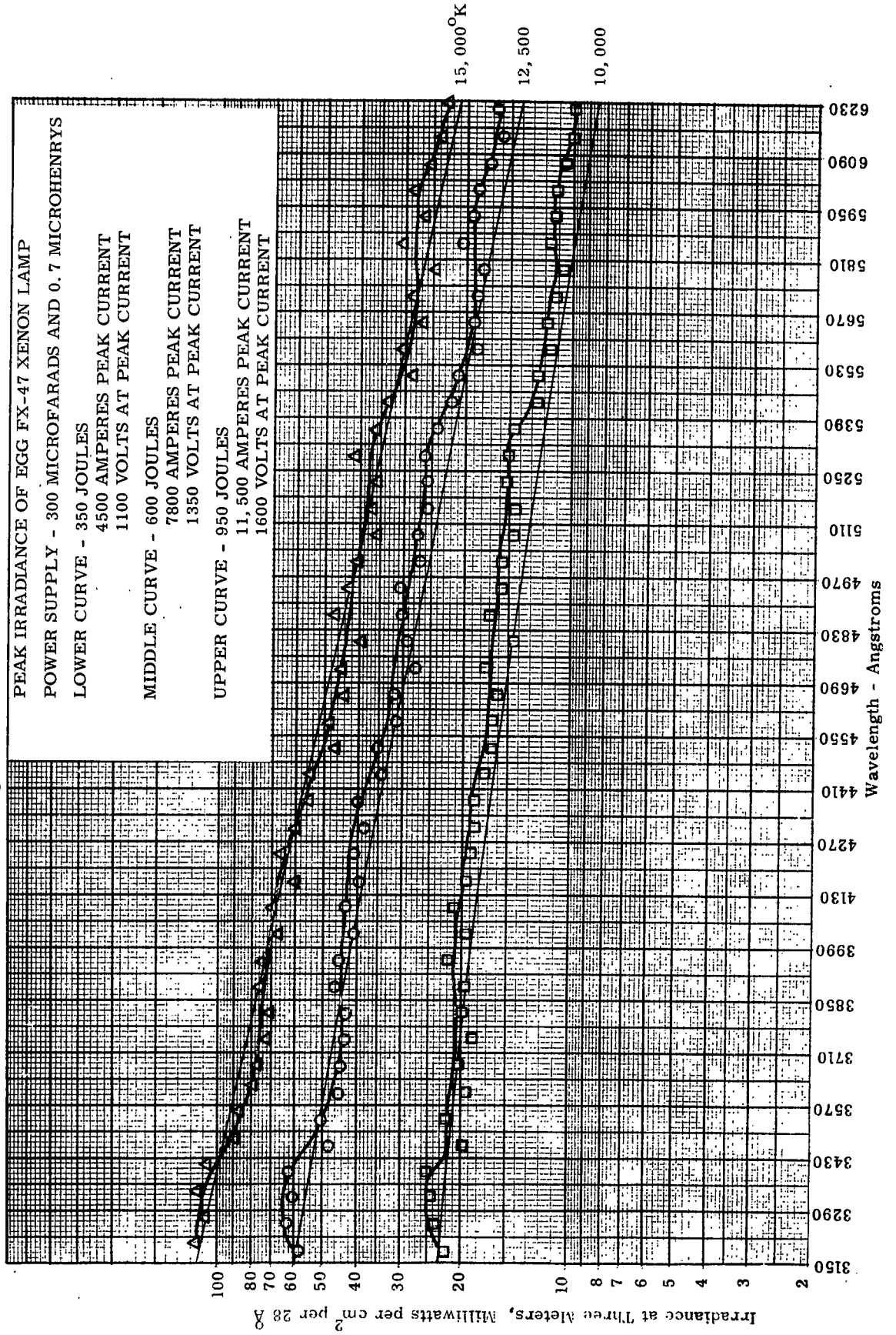

### Metal Iodide Lamps

Figure 11 shows the results of tests with metal iodide doping in 100 torr xenon. The high current circuit was without a choke as in the case of the FX-47, but the pre-ionizing current was run at 1500 amperes instead of 1000 amperes. The higher pre-ionizing current was required to establish a well-behaved discharge. Lower pre-ionizing current resulted in fluctuations of current and voltage, and double peaking in many of the traces of irradiance.

Lamp temperature was approximately 700°C for these tests. However, throughout the tests, there was a small amount of condensate deposited in the lamp between the electrodes. The results were repeatable from flash to flash, but the vapor pressure during the high current discharge was higher than would have been obtained had there been no condensate between electrodes. The absorption lines are the principal metal lines. The principal lines of gallium are 4033 Å and 4172 Å, and the principal lines of thallium are 5350 Å, 3776 Å, 3529 Å, and 3230 Å. Generally speaking, the metal iodide resulted in absorption rather than higher emission.

There is no place in the spectrum from 3200 Å to 6200 Å where the metal iodide can be said to have resulted in higher spectral irradiance than can be obtained from an FX-47. Figure 12 shows some sample traces from the tests.

Figure 13 gives irradiance for a metal iodide lamp with 50 torr xenon. We were unable to obtain a well-behaved discharge in this lamp without a choke in the high current circuit. A choke was used so as to lengthen the flash to approximately 0.2 milliseconds. The main current pulse was switched 50 to 100 microseconds after the lamp was ignited with the 33 kilovolt capacitor. No pre-ionizing discharge was used.

Figure 11

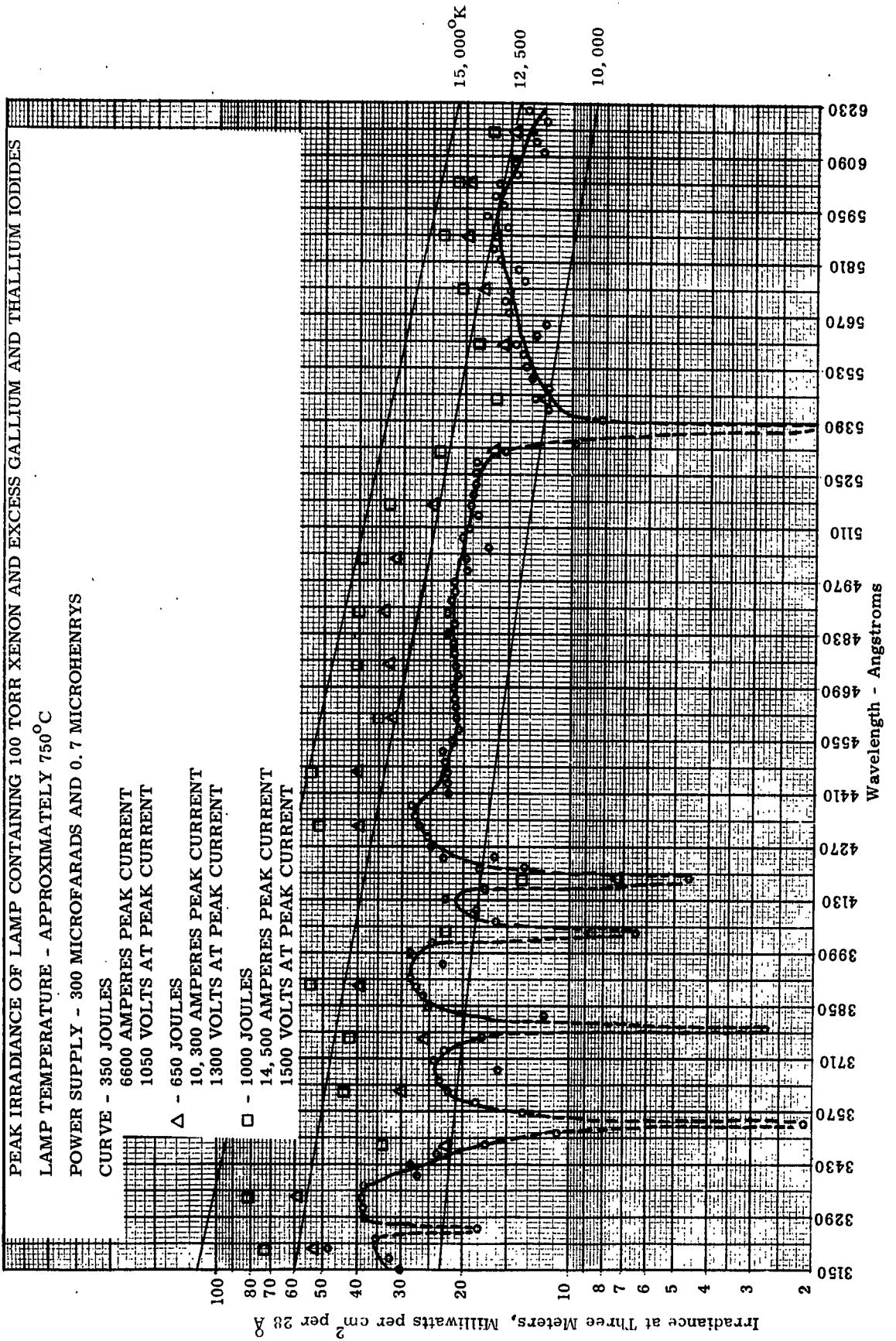

FIGURE 12 SAMPLE SCOPE TRACES

LAMP CONTAINING 100 TORR XENON AND EXCESS GALLIUM AND THALLIUM IODIDES

14,500 AMPERES PEAK CURRENT

1,500 VOLTS AT PEAK CURRENT

TIME SCALE - 20 MICROSECONDS PER DIVISION

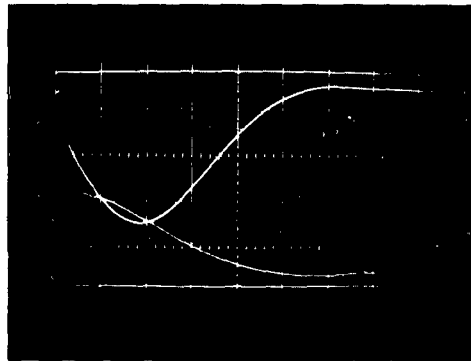

CURRENT

LAMP VOLTS



IRRADIANCE

3206 Å

3366

3506

3646

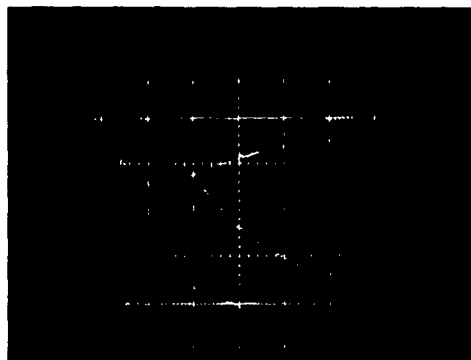

3786

3926

4066

4206

Figure 13

PEAK IRRADIANCE OF LAMP CONTAINING 50 TORR XENON AND EXCESS GALLIUM AND THALLIUM IODIDES  
LAMP TEMPERATURE - APPROXIMATELY 700°C

LOWER CURVE - 300 MICROFARADS, 26 MICROHENRYS, 650 JOULES  
4500 AMPERES PEAK CURRENT  
950 VOLTS AT PEAK CURRENT

UPPER CURVE - 600 MICROFARADS, 13 MICROHENRYS, 1300 JOULES  
8000 AMPERES PEAK  
1200 VOLTS AT PEAK CURRENT

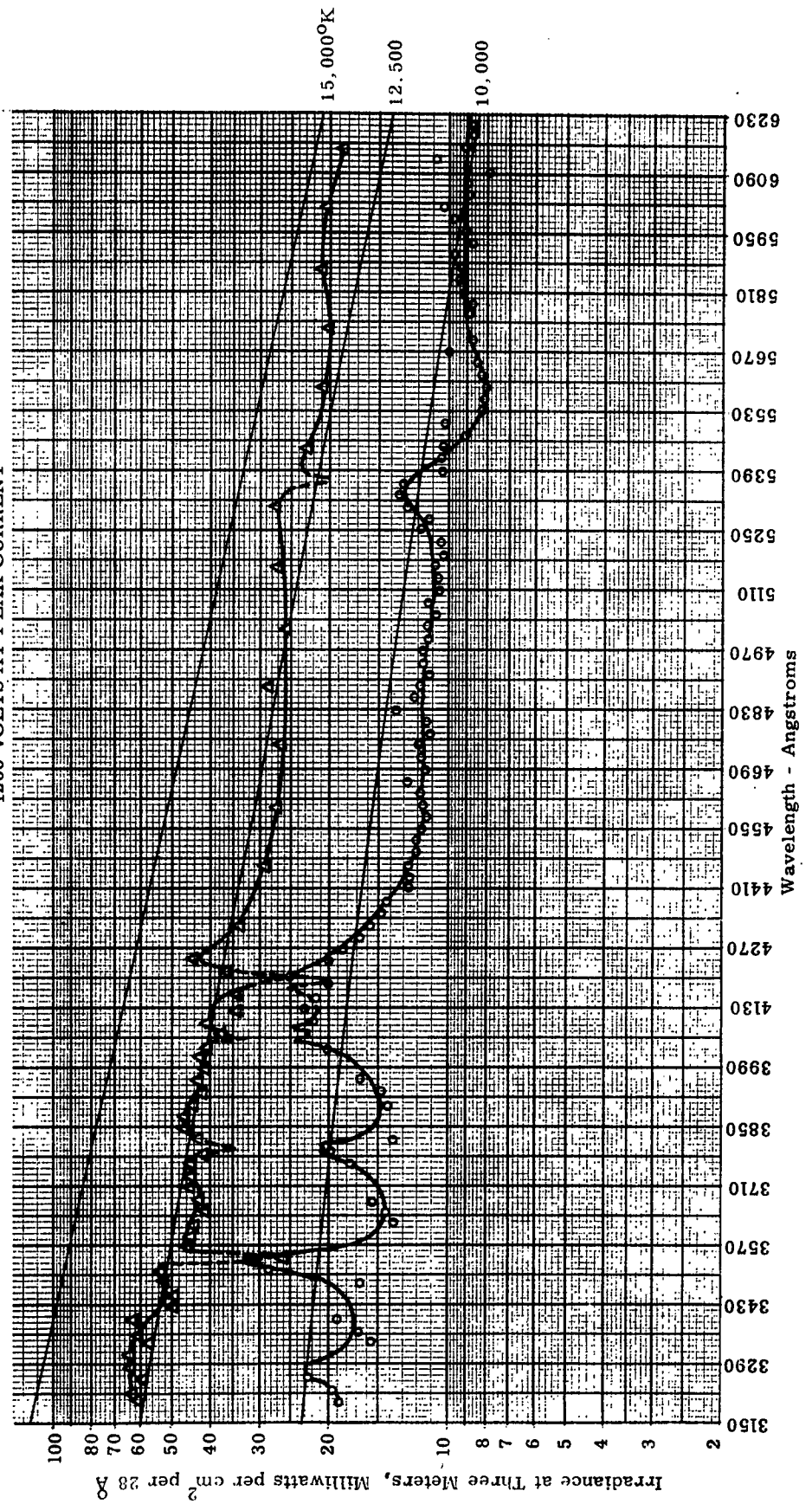

Clearly, the concentration of metal iodide vapor was less for this test than for the test with 100 torr xenon. At the low current there was pronounced enhancement of spectral irradiance at the principal lines of the metals. Enhancement at the 5350<sup>0</sup>Å line of thallium was much less than at the blue and near ultraviolet lines of the metals. At the higher loading, the spectrum was very much like that of the FX-47, the metal iodides giving very little enhancement. Figure 14 shows sample traces from tests on this lamp. At points in the spectrum where there was appreciable line absorption, the traces of spectral irradiance are relatively flat.

From the test on this lamp, it appears that the metal iodides can be used at relatively low loadings in 0.5 inch ID lamps to obtain spectral enhancement. However, the objective here is higher irradiance than is available with the state of the art, and the results of tests on this lamp show that metal iodides were of no help.

Figure 15 gives irradiance at low current for a metal iodide lamp containing 25 torr xenon. The lamp was flashed in the same way as the one containing 50 torr, approximately 0.2 millisecond flashes. Keeping the voltage on the bank constant from flash to flash, the relative change in irradiance of the lamp was observed as the lamp temperature was raised. Irradiance continued to increase with temperature, but rather slowly at high temperature. Complete data was then taken at approximately 900°C.

It is seen from Figure 15 that the spectrum of this lamp is considerably different from that of the FX-47. Peak irradiance is somewhat lower over the measured band than for an FX-47 at equal power. Similar tests will be carried out at higher peak power.

FIGURE 14 SAMPLE SCOPE TRACES

LAMP CONTAINING 50 TORR XENON AND EXCESS GALLIUM AND THALLIUM IODIDES

8000 AMPERES PEAK CURRENT

1200 VOLTS AT PEAK CURRENT

TIME SCALE - 50 MICROSECONDS PER DIVISION

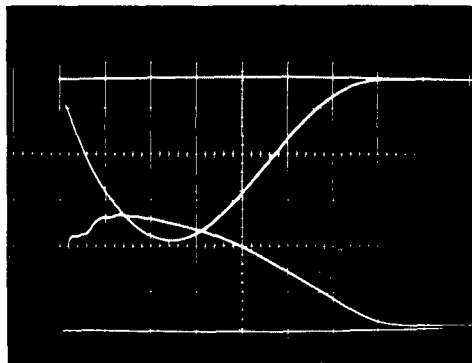

CURRENT

LAMP VOLTS

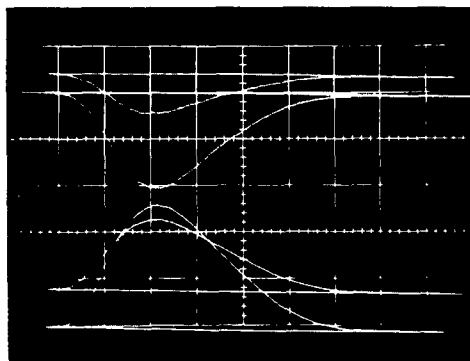

RADIANCE

3220 Å

3360

3500

3640

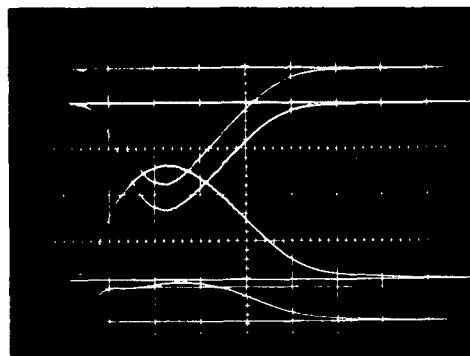

3780

3920

4060

4200

**Figure 15**  
**PEAK IRRADIANCE OF LAMP CONTAINING 25 TORR Xe, EXCESS GALLIUM AND THALLIUM IODIDES**  
**LAMP TEMPERATURE - APPROXIMATELY 850°C**  
**POWER SUPPLY - 300 MICROFARADS, 25 MICROHENRYS, 950 JOULES**  
**4000 AMPERES PEAK CURRENT**  
**1100 VOLTS AT PEAK CURRENT**

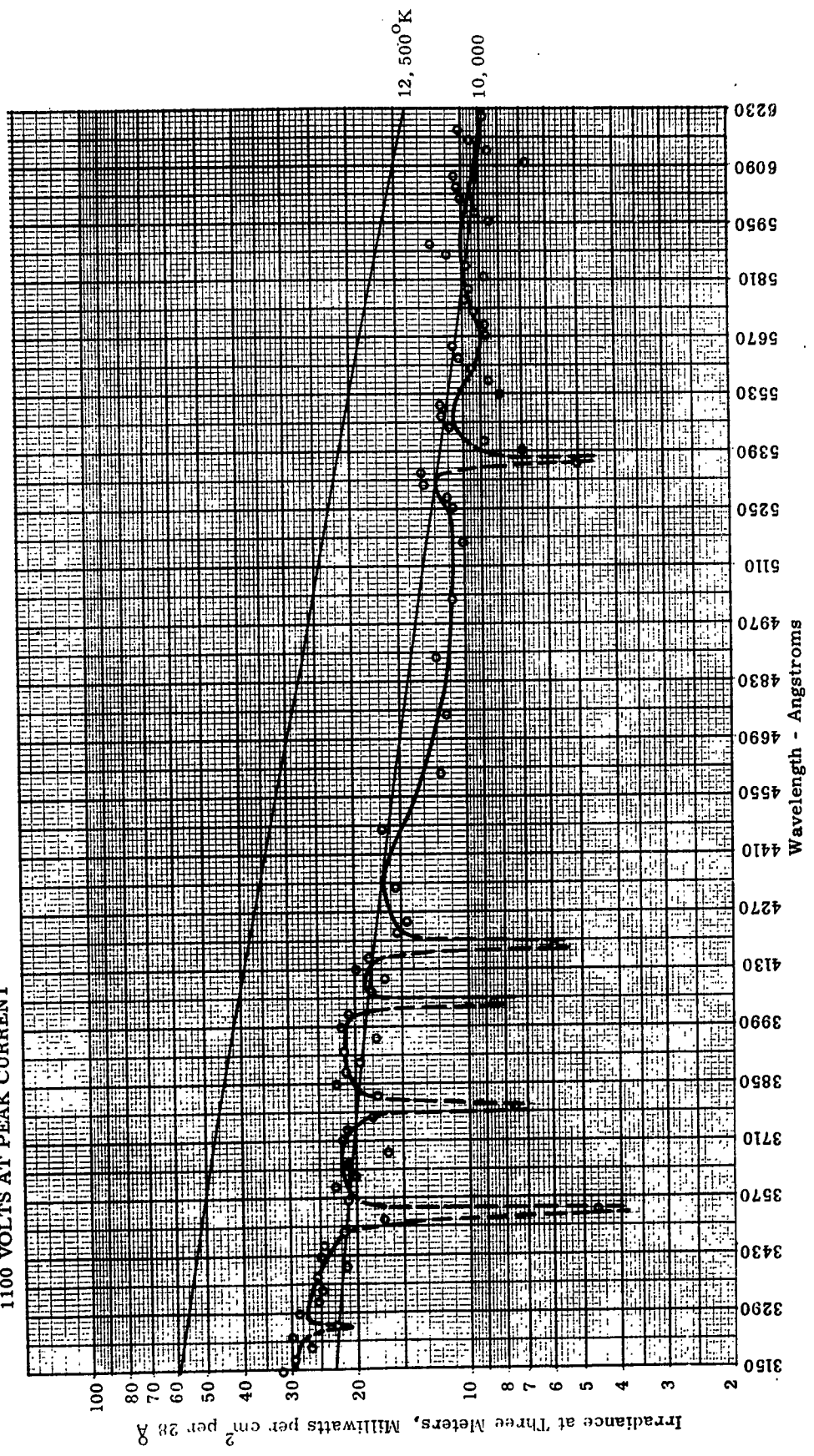

## DISCHARGE CHAMBER TESTS WITH NEON

Tests with neon have been conducted in a de-mountable discharge chamber made from a straight piece of quartz glass tubing and metal end sections with tungsten electrodes mounted on them. The quartz tubing is vacuum sealed to the metal ends with a standard vacuum coupler, and the discharge chamber is connected to a vacuum pump and gas filling system through one of the end assemblies. Figure 16 is a photograph of the discharge chamber mounted in the test stand.

The chamber was outgassed after evacuation by filling with neon, flashing it several times, and then evacuating it again. When breakdown voltage rose to a high level due to further outgassing from high loading, the chamber was evacuated and refilled.

Quartz tubing available from stock at General Electric was used. It is 0.5 inch ID and 0.75 inch OD. Tubing was annealed after it was cut and fire polished, and then put in full strength hydrofluoric acid for 15 minutes to clean it and etch out sharp edges and grooves. We have had only one tube burst, and this occurred when a 70,000 ampere discharge was run with an initial pressure of a half atmosphere. The peak power in this discharge was approximately 200 megawatts.

Tungsten electrodes of 3/8 inch diameter were used. They performed well for currents of 35,000 amperes or less, amounting to approximately 50,000 amperes per cm<sup>2</sup> of useful electrode area. This is the maximum loading an electrode can normally be expected to handle without excessive electrode drop and accompanying evaporation. The electrode area can be increased to handle higher current. The ends of the discharge tube could be enlarged to accept larger electrodes if necessary.

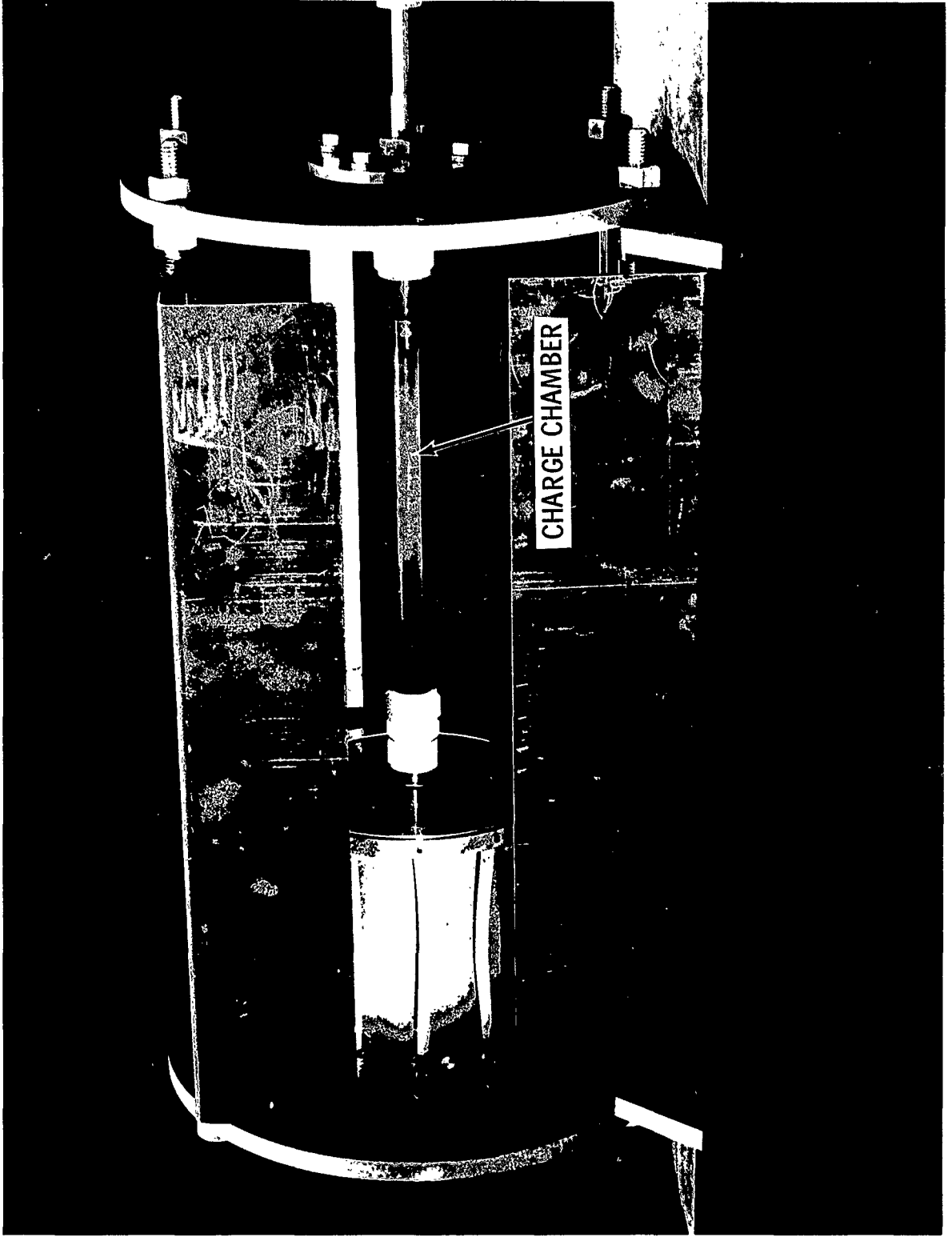

Figure 16. Discharge Chamber Mounted in Test Stand.

Tests were carried out at two pulse lengths, approximately 150 microseconds and 50 microseconds. A pre-ionizing discharge was used with 50 microsecond flashes. A considerable amount of difficulty was experienced in obtaining a well-behaved discharge. The best operation with 150 microsecond flashes was obtained using 50 to 100 microseconds delay of the start of the high current discharge from the initiating discharge.

A peculiarity of the short pulse in neon is the long delay in the peak of irradiance from the peak of the current. Twenty microseconds delay for a 50 microsecond flash was quite common.

The resistance of the neon discharge at high loading was approximately 0.6 that of a xenon discharge for comparable pressure and loadings. This is indicative of a considerably higher temperature in neon than in xenon.

#### IRRADIANCE OF NEON DISCHARGES

Figure 17 gives the results of irradiance measurements at different pressures, 50 torr, 200 torr and 800 torr. The pulse length was approximately 150 microseconds. The spectrum contains a large amount of line radiation, and transparency of the discharge increases with decreasing wavelength. For 200 torr, irradiance at  $6100 \text{ \AA}$  was nearly equal to that of a  $20,000^\circ\text{K}$  black body. It is probable that the discharge had appreciable transparency also at  $6100 \text{ \AA}$ .

The lowest pressure gave the highest peak irradiance over most of the spectrum. However, peak power was greatest for the lowest pressure. The chamber could be flashed many times at the lower pressures without appreciable deterioration of the chamber. However, flashing with 800 torr resulted in excessive clouding of the quartz wall.

Figure 17

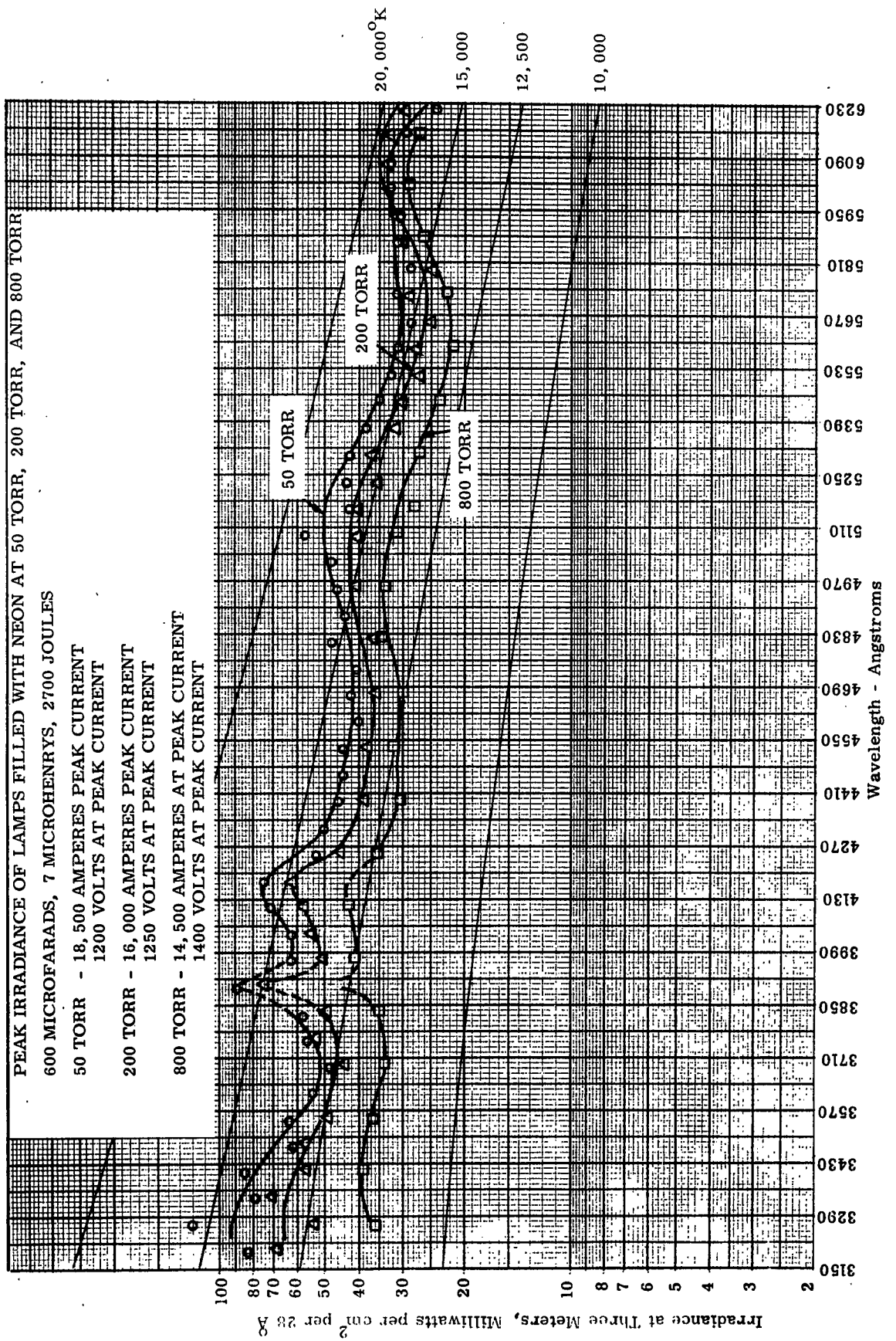

Figure 18 gives the results of irradiance measurements for different loadings. The pressure was 400 torr, the flash was approximately 50 microseconds long, and a 2000 ampere pre-ionization discharge was used. The highest loading resulted in some clouding of the quartz. Higher loadings than those shown for Figure 18 resulted in severe darkening of the tube from electrode erosion.

It is seen that the discharge is still quite transparent at wavelengths shorter than those of the broad peak centered at approximately 6100 Å. Transparency at 6100 Å has not been determined. Irradiance at 6100 Å for the high loading was approximately equal to that of a 30,000°K black body.

Figure 18  
 PEAK IRRADIANCE OF A LAMP FILLED WITH 400 TORR NEON

