

**Best
Available
Copy**

UNCLASSIFIED

AD

4 3 8 5 1 7

DEFENSE DOCUMENTATION CENTER

FOR

SCIENTIFIC AND TECHNICAL INFORMATION

CAMERON STATION ALEXANDRIA VIRGINIA



UNCLASSIFIED

NOTICE: When government or other drawings, specifications or other data are used for any purpose other than in connection with a definitely related government procurement operation, the U. S. Government thereby incurs no responsibility, nor any obligation whatsoever; and the fact that the Government may have formulated, furnished, or in any way supplied the said drawings, specifications, or other data is not to be regarded by implication or otherwise as in any manner licensing the holder or any other person or corporation, or conveying any rights or permission to manufacture, use or sell any patented invention that may in any way be related thereto.

64-13

RTD-TDR-63-4057

438517

**A STUDY OF
AN ORBITAL MAINTENANCE AND MATERIAL TRANSFER
SHUTTLE**

CATALOGED BY DDC
AS AD No. _____

TECHNICAL DOCUMENTARY REPORT No. RTD-TDR-63-4057

MARCH 1964

AERO PROPULSION LABORATORY
RESEARCH AND TECHNOLOGY DIVISION
AIR FORCE SYSTEMS COMMAND
WRIGHT-PATTERSON AIR FORCE BASE, OHIO

Project No. 8170, Task No. 817010

MAY 12 1964

LIBRARY
TISA R

Prepared under Contract No. AF 33(657)-10290 by the
Spacecraft Organization, Lockheed-California Company,
Burbank, California; Ray Goodall, et al, authors.

438517

NOTICES

When Government drawings, specifications, or other data are used for any purpose other than in connection with a specifically identified Government procurement operation, the United States Government thereby incurs no responsibility nor any obligation whatsoever, and it is noted that the Government drawings, specifications, furnished, or in any way supplied the said drawings, specifications, or other data, is not to be regarded by anyone as in any manner licensing the holder or any other person or corporation, or conveying any rights or permission to manufacture, use, or sell any patented invention that may in any way be related thereto.

Qualified requesters may obtain copies of this report from the Defense Documentation Center (DDOC) (for information) at Cameron Station, Bldg. 3, 5010 Duke Street, Alexandria 4, Virginia.

This report has been released by the Office of Technical Services, U.S. Department of Commerce, Washington 25, D.C. to the general public.

Copies of this report should be returned to the Aeronautical Systems Division unless return is required by security considerations, contractual obligations, or holder on a specific document.

FOREWORD

This report was prepared by the Spacecraft Organization of the Lockheed-California Company, Burbank, California, under Air Force Contract AF 33(657)-10290, Design Study for an Orbital Maintenance and Material Transfer Shuttle. The work was administered under the direction of the Site Support Branch of the Aero Propulsion Laboratory, Research and Technology Division, Wright-Patterson Air Force Base, Ohio. Mr. John Tackis served as project engineer for the Air Force.

The study commenced in February 1963 and concluded in October 1963; it was performed by the Spacecraft Organization, Lockheed-California Company. Mr. W. Goodall, project engineer, was responsible for this study activity.

This report (Lockheed's LR 17031) is the final technical report of the study. A development plan and cost estimate for the production of two shuttle vehicles is presented in a separately bound addendum (LR 17032).

The assistance of Rocketdyne, Messerschmitt Corporation, AiResearch Manufacturing Company, and Hamilton Standard in the design of the propulsion and environmental control systems is acknowledged. Specific contributions are identified in the text.

ABSTRACT

A conceptual study of an orbital maintenance and material transfer shuttle is presented. The shuttle is a one-man vehicle used for transporting personnel and materials between other orbiting vehicles and for performing maintenance and repair on space stations or unmanned satellites.

The application of the shuttle to existing and proposed space systems is examined and found to be feasible and economically advantageous. The trade-offs between range, duration, propulsion and on-board power systems are presented and design values selected. A simple guidance technique using a short-range radar is formulated.

Results of simulated maintenance experiments conducted with a worker in a pressure suit are reported and integrated into the shuttle design.

A preliminary design of the vehicle with definitive weights and subsystem characteristics is presented.

This technical documentary report has been reviewed and is approved.

Marc P. Dunnam
MARC P. DUNNAM, Chief
Technical Support Division
AF Aero Propulsion Laboratory

TABLE OF CONTENTS

Section		Page
1	INTRODUCTION AND SUMMARY	1
	1.1 Problem Statement	1
	1.2 Study Approach	2
	1.3 Results	2
	1.3.1 Mission Definition	2
	1.3.2 Shuttle Effectiveness	2
	1.3.3 Design Range	8
	1.3.4 Propellant Requirements	8
	1.3.5 Electrical Requirements	11
	1.3.6 Mission Duration	11
	1.3.7 Rendezvous Technique	11
	1.3.8 Maintenance Technique Evaluation	11
	1.3.9 Preliminary Design	16
	1.3.10 Problem Areas	17
2	MISSION DEFINITION	23
	2.1 Space Systems Definition	23
	2.2 Space System - Shuttle Integration	30
	2.2.1 Gemini and Shuttle	30
	2.2.2 Apollo and Shuttle	31
	2.2.3 Small Space Station and Shuttle	31
	2.2.4 Large Space Station	35
	2.2.5 Multiple-Manned Systems	36
	2.2.6 Space Stations and Unmanned Satellites	39
	2.2.7 Interplanetary and Lunar Missions	40
	2.3 Summary - Mission Definition	41
3	SHUTTLE CONCEPTS ANALYSES	43
	3.1 System Trade-Offs	43
	3.1.1 Cost Effectiveness of Shuttle	43

TABLE OF CONTENTS (cont'd.)

Section		Page
3	3.1.2 Propulsion System-Mission Considerations	66
	3.1.3 Maintenance Mission Performance vs Equipment Weight	77
	3.1.4 System Trade-Off Summary	84
	3.2 Operational Considerations	87
	3.2.1 System Design and Operation	87
	3.2.2 Emergency Situations and Procedures	88
	3.3 Mission Performance	101
	3.3.1 Vehicle and Mission Parameters	101
	3.3.2 Preflight and Flight Segments	105
	3.3.3 Functional Segments of the Mission	111
	3.3.4 Design Requirement Summary	117
	3.4 Shuttle Configuration	124
	3.4.1 Configuration Constraints	124
	3.4.2 Configuration Concepts	124
	3.5 Shuttle System Evaluation	136
4	ASTRODYNAMICS AND RENDEZVOUS TECHNIQUE	139
	4.1 Launch Injection Errors	139
	4.1.1 Objective	139
	4.1.2 Analytical Model	140
	4.1.3 Sources of Error	142
	4.1.4 Source Errors - Summary	149
	4.1.5 Rendezvous Error	150
	4.2 The Effect of Hohmann Transfer Errors on Closest Approach to a Target	156
	4.3 Rendezvous Characteristic Velocity and Transfer Times	161
	4.3.1 Introduction	161
	4.3.2 In-Plane Transfers	161
	4.3.3 Characteristic Velocity Requirements for Short-Time Out-of-Plane Rendezvous	166

TABLE OF CONTENTS (cont'd.)		
Section		Page
4	4.4 Range Variation With Time	174
	4.4.1 Introduction	174
	4.4.2 Altitude Error	174
	4.4.3 Velocity Error	176
	4.4.4 Orbit Plane Error	176
	4.5 The Forces Required to Maintain Two Space Vehicles in Constant Relative Position	179
	4.5.1 Introduction	179
	4.5.2 Equal Altitude Station Keeping	180
	4.5.3 Station Keeping Directly Above or Below Target	181
	4.5.4 Conclusion	182
	4.6 Rendezvous Techniques	184
	4.6.1 Navigation and Guidance Operational Criteria	184
	4.6.2 Target Acquisition and Tracking	185
	4.6.3 Sensor Precision Required	191
	4.6.4 Review of the SMU Guidance Technique	199
	4.6.5 Variations of the SMU Guidance Technique	210
	4.6.6 A Communication Scheme for a Back-Up Guidance Mode	220
	4.6.7 Conclusions and Recommendations	224
5	HUMAN FACTORS	229
	5.1 Life Support	229
	5.2 Shuttle - Crew Integration	230
	5.3 Maintenance and Repair Task Analysis	231
	5.3.1 Maintenance Task Simulation Test Program	249
	5.3.2 Maintenance Technique Evaluation	253
	5.3.3 Conclusions	259
	5.4 One-Man Vs Multiple Crew	261
6	PRELIMINARY DESIGN	263
	6.1 General Description	263

TABLE OF CONTENTS (cont'd.)

Section		Page
6	6. 1. 1 Introduction	263
	6. 1. 2 Arrangement	263
	6. 1. 3 Propulsion Installation	264
	6. 1. 4 Docking Hatch	272
	6. 1. 5 Grapplers	272
	6. 1. 6 Capsule Shapes	276
	6. 1. 7 Canopy Capsule	276
	6. 1. 8 Thermal Control Provisions	281
6. 2	Environment Control System	283
	6. 2. 1 Introduction	283
	6. 2. 2 System Requirements	283
	6. 2. 3 System Synthesis	285
	6. 2. 4 System Description	288
6. 3	Propulsion	293
	6. 3. 1 System Functions and Requirements	293
	6. 3. 2 System Design	293
	6. 3. 3 Propellant Tanks	299
	6. 3. 4 Pressurant Tank	302
	6. 3. 5 Operational Considerations	305
	6. 3. 6 Reliability Considerations	306
6. 4	Stability and Control System	307
	6. 4. 1 Design Requirement	307
	6. 4. 2 Operation	307
	6. 4. 3 Control Methods	309
	6. 4. 4 System Components	313
6. 5	Navigation and Guidance	315
6. 6	Electrical Power System	320
	6. 6. 1 Design Considerations	320
	6. 6. 2 System Description	322

TABLE OF CONTENTS (cont'd.)

Section		Page
6	6.7 Communications	324
	6.7.1 Design Considerations	324
	6.7.2 Component Description	326
	6.8 Structural Systems	327
	6.8.1 Introduction	327
	6.8.2 Requirements	327
	6.8.3 Structure - General	328
	6.8.4 Windows	329
	6.8.5 Grapplers	330
	6.8.6 Meteoroid Protection	330
	6.9 Weight Statement	330
	6.10 Cockpit Arrangement	336
	6.10.1 Hatches	336
	6.10.2 Shelter	336
	6.10.3 Working Aids	336
	6.10.4 Crew Support	341
	6.10.5 Controls and Displays	341
	6.10.6 Curtains	342
	6.10.7 Life Support	342
	6.10.8 Maintenance Equipment Arrangement	342
	6.11 GRAPPLER SYSTEM	345
	6.11.1 System Description	345
	6.11.2 Grappler Control	346
	6.11.3 Structure	346
	6.11.4 Adhesive Pads	346
	6.12 RELIABILITY	351
	6.12.1 Mission Implications on Reliability	351
	6.12.2 Critical Systems and Operations	351
	6.12.3 Shuttle System Design for Reliability	352
	6.12.4 Component Reliability	354
7	PROBLEM AREAS	355
	7.1 Repair and Maintenance Techniques	355
	7.2 Shuttle Vehicle Design	356
	References	357

LIST OF ILLUSTRATIONS

Figure		Page
1-1	Equal Cost Material Transfer Missions	7
1-2	Shuttle vs Replaceable Systems	7
1-3	Subsystem Weight vs Mission Time	9
1-4	Propellant and Electrical Requirements	10
1-5	Shuttle Trainer Arrangement	19
1-6	Shuttle Inboard Profile	21
2-1	Six-Man Station - Resupply	33
2-2	Requirements for Resupply Launches, Saturn C-1B	37
2-3	Requirements for Resupply Launches, Saturn C-1	37
3-1	Primitive vs Shuttle Operation, Equal-Costs Based on Weight in Orbit	48
3-2	Launch Cost	50
3-3	Remote Control Module Equal-Cost Chart	55
3-4	Escape Module - Shuttle Equal-Cost	57
3-5	Repair by Shuttle vs Replacement	61
3-6	Braking Distance (0.2 sec Delay Time)	68
3-7	Required Range vs Available Range	70
3-8	Contours of Constant Characteristic Velocity	71
3-9	Non-Impulsive Thrusting ΔV Correction	73
3-10	Propulsion - Mission Interaction	74
3-11	Optimum Thrust for Orbital Shuttle	78
3-12	Optimum Thrust for Orbital Shuttle with Payload	78
3-13	Reconnaissance Mission Satellite Systems	80
3-14	Shuttle Weight Increase with Increase in Probability of Mission Success	81
3-15	Booster Transport	94
3-16	Transfer Time vs Propellant	104
3-17	Astrotug Detail	127
3-18	Minimum Shuttle Concept	129
3-19	Long-Range Shuttle	130

LIST OF ILLUSTRATIONS (Cont'd)

Figure		Page
3-20	Maintenance, Center Operation	131
3-21	Multi-Engine Shuttle	133
3-22	Boom Shuttle	134
3-23	Boom Shuttle with Sleeves	135
4-1	Trajectory Relations Between the Unmanned Supply Vehicle and the Primary Vehicle	141
4-2	Rendezvous Miss Distance Probability	152
4-3	Change in Miss Distance with Time	155
4-4	Definition of Target-Centered Rotating Coordinate System	157
4-5	Orbits in Inertial Geocentric Coordinates	158
4-6	Closest Approach to Target as a Function of Error in Initial Y	159
4-7	Closest Approach to Target as a Function of Error in Initial X	159
4-8	Position of Closest Approach	160
4-9	Position of Interceptor with Respect to Target Vehicle at Estimated Time of Rendezvous	160
4-10	Orbits in an Inertial Geocentric Coordinate System	162
4-11	Trajectories to Rendezvous from 20 miles in 300 Seconds	164
4-12	Trajectories to Rendezvous from 20 miles in 2500 seconds	164
4-13	Characteristic Velocity versus Total Time for Rendezvous Transfer from a Range of 20 nautical miles	167
4-14	Maximum Characteristic Velocity vs Range	168
4-15	Characteristic Velocity vs Range	169
4-16	Characteristic Velocity vs Range Time = 600 sec	170
4-17	Contours of Constant Characteristic Velocity	171
4-18	Analytical Model	172
4-19	Characteristic Velocity vs Time for Short-Time, Out-of-Plane Rendezvous	173
4-20	Analytical Model	175

LIST OF ILLUSTRATIONS (Cont'd)

Figure		Page
4-21	Propagation of an Error of 20 n.mi. in Initial Position	177
4-22	Propagation of a Tangential Error of 16.2 fps in the Injection Velocity	178
4-23	Lighting Geometry	186
4-24	Duration of Eclipse as a Function of Orbit Inclination	188
4-25	Visual Angle Obstructed by Earth	189
4-26	Target Range vs Diameter Visual Magnitude - 3	189
4-27	Shuttle Guidance System Sensed Information and Transformation for Proportional Navigation	195
4-28	Stability of SMU Technique (variable closing rate)	204
4-29	Stability of SMU Technique (variable Y_o)	204
4-30	Critical Velocity for SMU Technique	205
4-31	Schematic of Terminal Rendezvous Situation and Behavior of Errors with Respect to Independent Variables	208
4-32	Influence of Correction Acceleration on X_c	212
4-33	Influence of Corrective Acceleration of Miss Distance Y_o	212
4-34	Influence of Vertical Velocity on X_c	213
4-35	Influence of Vertical Velocity on Miss Distance	213
4-36	Typical SMU Trajectories	215
4-37	Flight Path Behavior of SMU Guidance Technique for Different Acceleration Levels	218
4-38	Geometry of Rendezvous Situation	221
4-39	Shuttle Range Uncertainty Due to Errors in Primary Vehicle Radar Measurements	223
5-1	Simulated Sleeve Vehicle Configuration	233
5-2	Open Hatch Vehicle 45 degree Configuration	233
5-3	Fuel Cell Replacement and Switch Replacement Problem	234
5-4	Open Hatch Vehicle Configuration Vertical	234
5-5	Engine Igniter Gasket Replacement Problem	235
5-6	Pressurized Mark 4 Suit	235

LIST OF ILLUSTRATIONS (Cont'd)

Figure		Page
5-7	Tools for Engine Igniter Gasket Replacement	236
5-8	Tools for Switch Replacement	236
5-9	Tools for Fuel Cell Replacement	237
5-10	Tools for Puncture Repair	237
5-11	Access to Igniter with Sleeves	238
5-12	Sleeves - Gasket Replacement	238
5-13	Use of Drill with Sleeves	239
5-14	Access to Fuel Cell Mounting Bolts with Sleeves	239
5-15	Use of Long Screw Driver for Switch Replacement	240
5-16	Modified Screw Driver for Switch Replacement	240
6-1	Shuttle General Arrangement	266
6-2	Shuttle Inboard Profile	267
6-3	Shuttle Pilot and Passenger Arrangement	269
6-4	Shuttle Remote Manipulator Arrangement	270
6-5	Shuttle Sleeve Arrangement	271
6-6	Shuttle Basic Capsule	273
6-7	Shuttle Engine Cluster	275
6-8	Shuttle Docking Hatch	277
6-9	Shuttle Canopy Capsule	279
6-10	Shuttle Shelter Application	282
6-11	Schematic Diagram Environmental Control System	286
6-12	Total Metabolic Heat Rejection for Pressure Suit Operation	289
6-13	Shuttle Engine Cluster	297
6-14	Shuttle - Propellant Tank	300
6-15	Shuttle - Pressurant Tank	303
6-16	Propulsion Jet Allocation and Orientation	308
6-17	Schematic - Main Thrust Pitch and Yaw Control	310
6-18	Schematic - Lateral Translation and Roll	311
6-19	Schematic - Vertical Translation and Roll Control	311

LIST OF ILLUSTRATIONS (Cont'd)

Figure		Page
6-20	Guidance and Control Block Diagram	312
6-21	Schematic - Navigation and Guidance System	316
6-22	Shuttle Radar and Visual Display	318
6-23	Power Supply Weight versus Mission Time	321
6-24	Diagram - Electrical Power System	323
6-25	Meteoroid Protection - Skin Weight vs Penetrations/Day	331
6-26	Shuttle Cockpit Arrangement	337
6-27	Shuttle Maintenance Equipment Arrangement	339
6-28	Shuttle Vision Envelope	343
6-29	Shuttle Remote Grappler System	349

LIST OF TABLES

Table		Page
1-1	Design Missions	3
1-2	Mission Duration Summary	12
1-3	Summary of Cumulative Task Times	13
1-4	Manipulator Requirements	15
1-5	Weight Summary	17
2-1	Launch Vehicles	25
2-2	Manned Spacecraft	26
2-3	Unmanned Spacecraft	27
2-4	Shuttle Missions with Two Manned Vehicles	38
3-1	Material Transfer Mission	51
3-2	Maintenance Equipment and Associated Weights	82
3-3	Maintenance Equipment Required for a Given Mission Success Probability	83
3-4	Mission Analyses and Results	86
3-5	Hazard and Escape Modes	89
3-6	Vacuum Tests of Adhesive Tapes	97
3-7	Vehicle and Mission Parameters	102
3-8	Design Mission Operations	103
3-9	Pre-Flight Activities	106
3-10	Take-Off and Cruise-Out	108
3-11	Propellant Requirements Return to Primary Mission Segment	109
3-12	Electrical Requirements - Return Segment	110
3-13	Assembly-Mission Fuel Expenditures	110
3-14	Propellant Requirements Mission Segment - Return to Primary	111
3-15	Station Repair	114
3-16	Typical Maintenance Tasks P-3A Electronic Systems	116
3-17	Missions Segment - Unmanned Satellite Repair	118
3-18	Propellant Requirement Summary	120

LIST OF TABLES (Cont'd)

Table		Page
3-19	Electrical Requirement Summary	121
3-20	Mission Duration Summary (In Minutes)	122
4-1	Acceleration Required to Stay at Various Distance Y_0	181
4-2	Acceleration Required to Stay at Various Distance Z_0	183
4-3	Target Illumination by Earth - 300 N. Mi.	191
4-4	Trajectory Variable Measurement Requirements	198
4-5	Influence of A_d , X , and Y_0 on Intercept	211
4-6	Energy Comparisons of Guidance Techniques Using A Visual Tracking Reference	220
4-7	Values of Range and Range Error for Variations in α	222
5-1	Maintenance Task Simulation - Replace Gasket on Starter Generator	241
5-2	Maintenance Task Simulation - Repair Meteoroid Puncture	244
5-3	Maintenance Task Simulation - Fuel Cell Replacement	245
5-4	Maintenance Task Simulation - Replace Switch	247
5-5	Manipulator Requirements	256
5-6	Manipulator Characteristics	257
5-7	Repair and Maintenance Technique Evaluation	260
6-1	Propellant Comparison	295
6-2	Weight Statement Preliminary Design, Maximum Mission	332
6-3	Weight Statement Preliminary Design, Training Mission	334

Section 1

INTRODUCTION AND SUMMARY

1.1 PROBLEM STATEMENT

Anticipated space activities for the near future include manned vehicles for a variety of purposes, in addition to numerous unmanned satellites. This space complex will require a logistics support system to perform the functions of transfer of personnel, materials, and equipment from one satellite to another; to perform maintenance and repair operations on both manned and unmanned vehicles; and to assemble near-earth space stations and vehicles for deep-space exploration. A small vehicle with a quick reaction time is envisioned for this logistics system to minimize the problems associated with the precise docking of large vehicles, and to efficiently perform rescue operations.

The specific purpose of this shuttle vehicle is to develop and exploit the capability of man to perform the basic missions described above. Therefore, a one-man capsule with the following characteristics is considered:

- Greater protection than is afforded by a space suit.
- Adequate tools and equipment for effective maintenance and repair
- Means to supplement man's strength and to provide mobility necessary for in-space assembly work
- Provision of material and supply handling devices to transport payloads exterior to the shuttle

The assumptions which provide the guidelines for this investigation are as follows:

1. A protective anthropomorphic suit will be available to the astronaut in case of emergencies.
2. Shuttle shall be complete within itself and be able to operate independently of the primary or target vehicle within its design range.

Manuscript released by the authors August 1963 for publication as an RTD Technical Documentary Report.

3. The shuttle shall not be required to enter a hazardous radiation envelope emitted by a nuclear power source.
4. Protection from extreme radiation levels caused by solar activity will not be provided. Protection will be afforded by the primary or target vehicles during extreme solar activity.
5. Initial orbital conditions of target relative to the primary vehicle will be given prior to departure.
6. The shuttle will be protected from air loads and heating during launch.
7. The shuttle will never reenter the atmosphere.

1.2 STUDY APPROACH

The study was conducted in two phases: an operations analysis and conceptual study, and a preliminary design of the vehicle. The final results are presented in this report, arranged to read from the general system considerations to the configuration development, and to the detail component design sections. The detail results presented in the later sections are used where necessary in the general sections of the report.

1.3 RESULTS

1.3.1 Mission Definition

The space systems projected are reviewed and techniques for applying the shuttle to each are described in Section 2. The results are used to define the eight design missions summarized in Table 1-1.

1.3.2 Shuttle Effectiveness

Many operations in space may benefit by the facilities supplied by the shuttle. Some assembly operations, for instance, may be impossible without

TABLE 1-1

DESIGN MISSIONS

MISSION	PRIMARY		TARGET		SHUTTLE PAYLOAD		Shuttle weight less crew <700
	Vehicle	Weight (lb)	Vehicle	Weight (lb)	Item	Weight (lb)	
Training	Gemini	7000	- -	- -	Experimental equip.		
Material Transfer	Space Station	30000	Unmanned module	2000	Cargo	2000	
	Space Station	150000	Recoverable booster	100000	Cargo	20000	
Personnel Transfer	Space Station	150000	Recoverable booster	100000	10 men	2000	
	Space Station	150000	Station	150000	Tools and spares	75	Extravehicular maintenance and repair on station. Main-tenance and re-pair of unmanned satellite
Maintenance	Space Station	150000	Unmanned satellite	500	Tools and spares	160	
	Space Station	150000	S-IV	117,000	S-IV	117,000	Retrieve, position, mate booster stages
Rescue	Space Station	150000	X-20	15,000	1 man	200	

heavy-duty manipulators. When the shuttle is advantageous, but not essential, the price attached to these benefits is of particular interest. Section 3.1.1, therefore, presents a comparison of the cost of operating space systems with and without the shuttle.

1.3.2.1 Basis of Effectiveness Study

The evaluation of the shuttle concept from an economic point of view is based on the cost of placing satellites in orbit. The launching costs are the dominant factor in the total cost of most space systems, and the dollars per pound in orbit is a convenient measuring stick for comparing the effects of changes in system operation. As the analysis is intended to apply to future systems, and as launch costs are expected to decrease, it is found desirable to include the effect of hardware costs in the analysis. "Hardware" includes the research and development charges allocated to the mission in question. The cost enters this analysis as the ratio

$$\frac{\text{Launch cost} + \text{hardware cost}}{\text{Launch cost} + \text{propellant cost}}$$

This ratio is termed the "cost factor" and may be taken as $1 + \frac{\text{hardware cost}}{\text{launch cost}}$ as propellant costs are low.

The shuttle may be used for many purposes thereby distributing shuttle hardware costs over all of the missions performed. The analysis recognizes this by introducing a utilization factor by which a proper allocation of shuttle hardware costs to any specific task may be made. This factor is taken as unity for each of the examples quoted in this summary. That is, each mission is treated as though the shuttle were used exclusively for that purpose.

The shuttle is light compared to the primaries of Table 1-1 which would be used if the shuttle were not available. The cost study based on weight in orbit is then, essentially, a comparison of propellant savings with the cost of the shuttle. These propellant savings are a function of the number of missions flown and the propellant required for each, which is related to the range over which the shuttle travels. The combination of number of sorties and

propellant required, may be expressed as a "mission constant" which is defined as $M = N \times (MR - 1)$.

A measure of the efficacy of the shuttle is the "equal cost" value of this mission constant, that value at which the cost of operating the system without the shuttle is equal to the cost of the system with the shuttle. The shuttle does the job that would be done by a heavier vehicle for most missions, and therefore is more advantageous as the length of the mission increases. The maintenance mission in which the shuttle cost is compared to the replacement cost of an unmanned satellite, differs in this respect. Increased range increases shuttle system cost compared to replacement cost; therefore, the mission constant defined above is not applicable to this mission. It is assumed that the unmanned satellites are placed in orbits close to the orbit of the primary.

The comparison of the shuttle to a remotely-controlled module involves recurring costs for the remotely-controlled hardware which is discarded after each flight. These costs are not related to the mass ratio, so the mission constant is not sufficient to describe this type of mission.

The missions examined in this study indicate that shuttle costs are rapidly recovered in reduced operational costs; typical examples are shown below.

1.3.2.2 Training Mission Effectiveness

The system considered for the training mission consists of a Gemini and the shuttle. It is assumed that space is available in the adapter to house the shuttle during launch and that a total weight of 700 pounds is available for the shuttle and its propellant. The basic shuttle developed from the preliminary design, stripped of special equipment for maintenance purposes, is equipped with a simple canopy instead of the shelter type used for maintenance operations. Radar and docking equipment are included to enable rendezvous experiments to be performed. A weight summary is given in Table 1-5. The equal cost mission constant shown represents the amount of maneuvering for which the propellant used by the heavier vehicle balances the cost of the shuttle and the propellant it uses. The entire cost of the shuttle is charged to one mission as it must be left in orbit. A cost factor of 1.5 is used in this example. The shuttle used in

this example yields a ΔV of 750 fps which is less than that of the 885 fps available if the 700 pounds is used for propellant for the 7,000-pound Gemini vehicle. However, the shuttle ΔV is sensitive to empty weight, for instance, if 17 pounds is removed the ΔV becomes 885 fps.

1.3.2.3 Material Transfer Missions Effectiveness

The range is a function of mass ratio for a given vehicle and transfer time; each mission constant then defines a set of ranges and numbers of sorties. These values are plotted in Fig. 1-1 for several material transfer operations. The curve for $M = .175$ compares the shuttle with a 7000-lb earth-to-orbit ferry used in the same manner. The payload is not a factor in this trade-off because it is handled in the same way in both systems. In the other examples plotted, a shuttle which travels to the payload and returns with it is compared with a primary which simply travels to the target. The ratio of target weight to primary weight is important in these cases because one system uses propellant to move the target and the other does not.

Both the use of a remotely controlled module for resupply operations and the total replacement mode of satellite maintenance involve discarding hardware. The comparison of these systems with the shuttle therefore involves the cost factor rather than the mission constant. The equal cost number of missions for these two missions is plotted in Fig. 1-2. The resupply module is assumed to have components equal in weight to the corresponding shuttle component, and the satellite being maintained is assumed equal in weight to the shuttle. A range requiring a mass ratio of 1.10 is also assumed.

Each curve in Fig. 1-1 and 1-2 defines for a particular type of mission the conditions under which a system with a shuttle is equal in cost to a system without a shuttle. Combinations of range and number of sorties, or of cost factor and sorties, which plot above and to the right of a curve indicate that the shuttle is advantageous for that case.

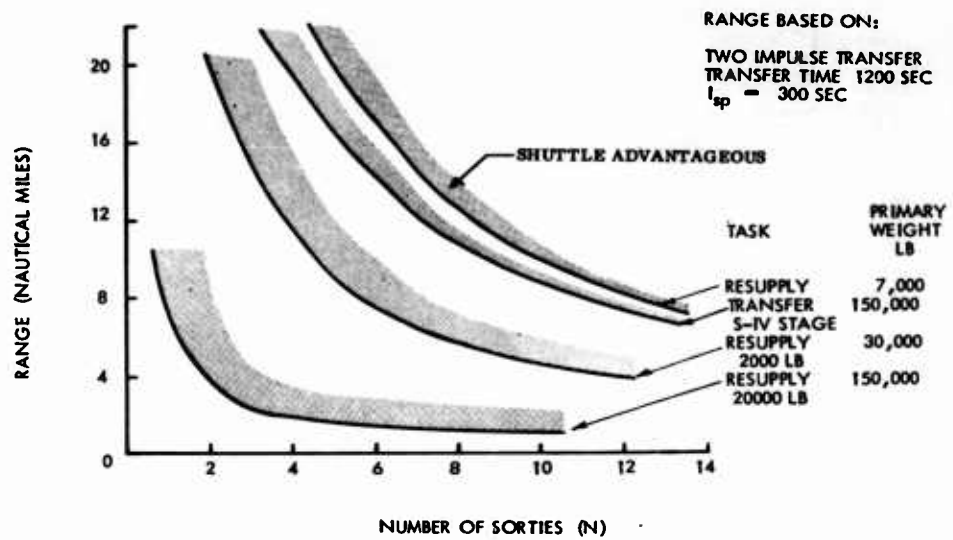

FIG. 1-1 EQUAL COST MATERIAL TRANSFER MISSIONS

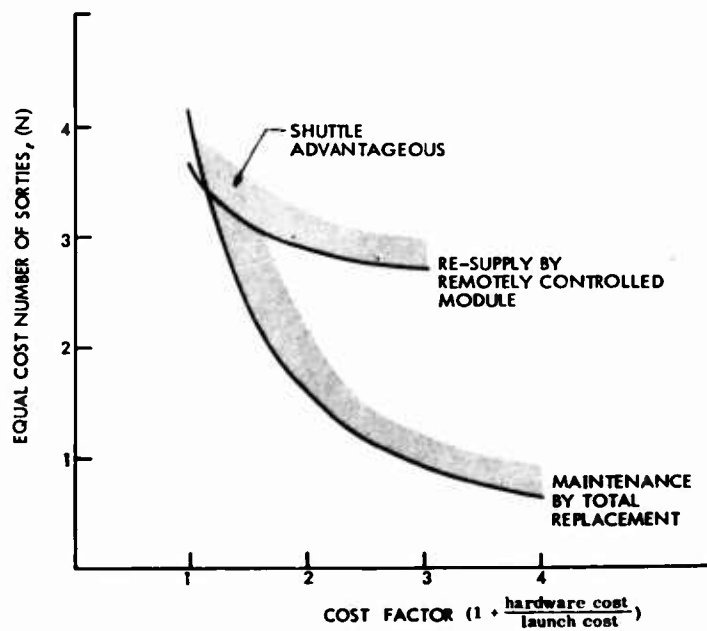

FIG. 1-2 SHUTTLE VS REPLACEABLE SYSTEMS

1.3.3 Design Range

The distance between a primary and a target vehicle resulting from the ascent errors expected when the target is launched from Earth by a typical booster is expected to have a $3\text{-}\sigma$ value of 12.1 n.mi. at injection. This range may increase to 20 n.mi. within an hour after orbit injection. The closest approach of a primary to a target resulting from a Hohmann transfer between two well known orbits is expected to have a $3\text{-}\sigma$ value within 8 n.mi. The maximum range considered for the shuttle is therefore 20 n.mi.

The propellant used in a 20 n.mi. transfer is a function of the time used for the transfer and the thrust level provided; the transfer time affects the weight of the on-board power and the environmental control systems. This trade-off is shown in Fig. 1-3.

1.3.4 Propellant Requirements

The propellant and electrical requirements calculated for the various missions and ranges considered are shown on the bar chart Fig. 1-4. Providing sufficient propellant for the entire mission when multiple trips are required, results in a vehicle grossly over-sized for other missions. It is more attractive to supply additional small vehicles, and to operate them as teams when necessary. Adopting this approach, it is seen that 200 pounds of propellant is adequate for all but the heavy payload missions. The reserve quantity is selected by giving the pilot enough propellant over the mission requirement to return without payload from 20 n.mi. in 20 min; this amounts to 65 pounds for the vehicle considered. Usable propellant of 265 pounds is therefore selected as the design value. In this chart, "A" represents material transfer missions, "B" personnel transfer missions, "C" maintenance, and "D" assembly missions as defined in paragraph 3.3.1.

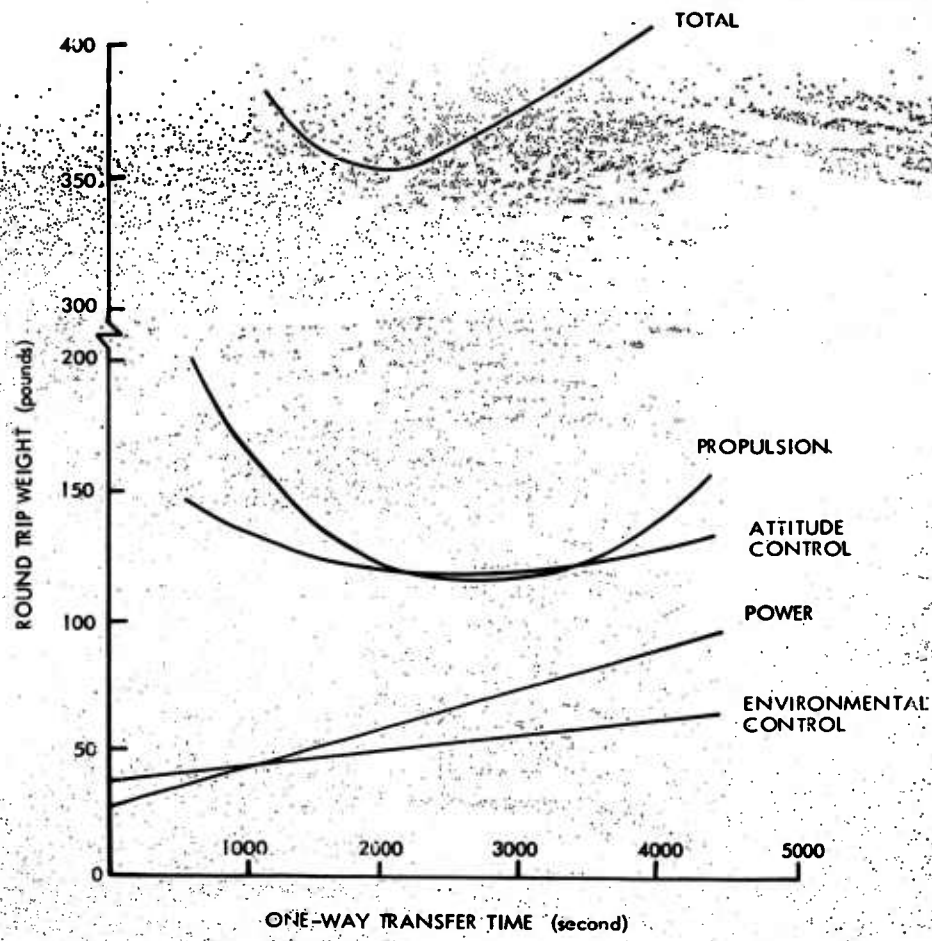

FIG. 1-3 SUBSYSTEM WEIGHT VS MISSION TIME

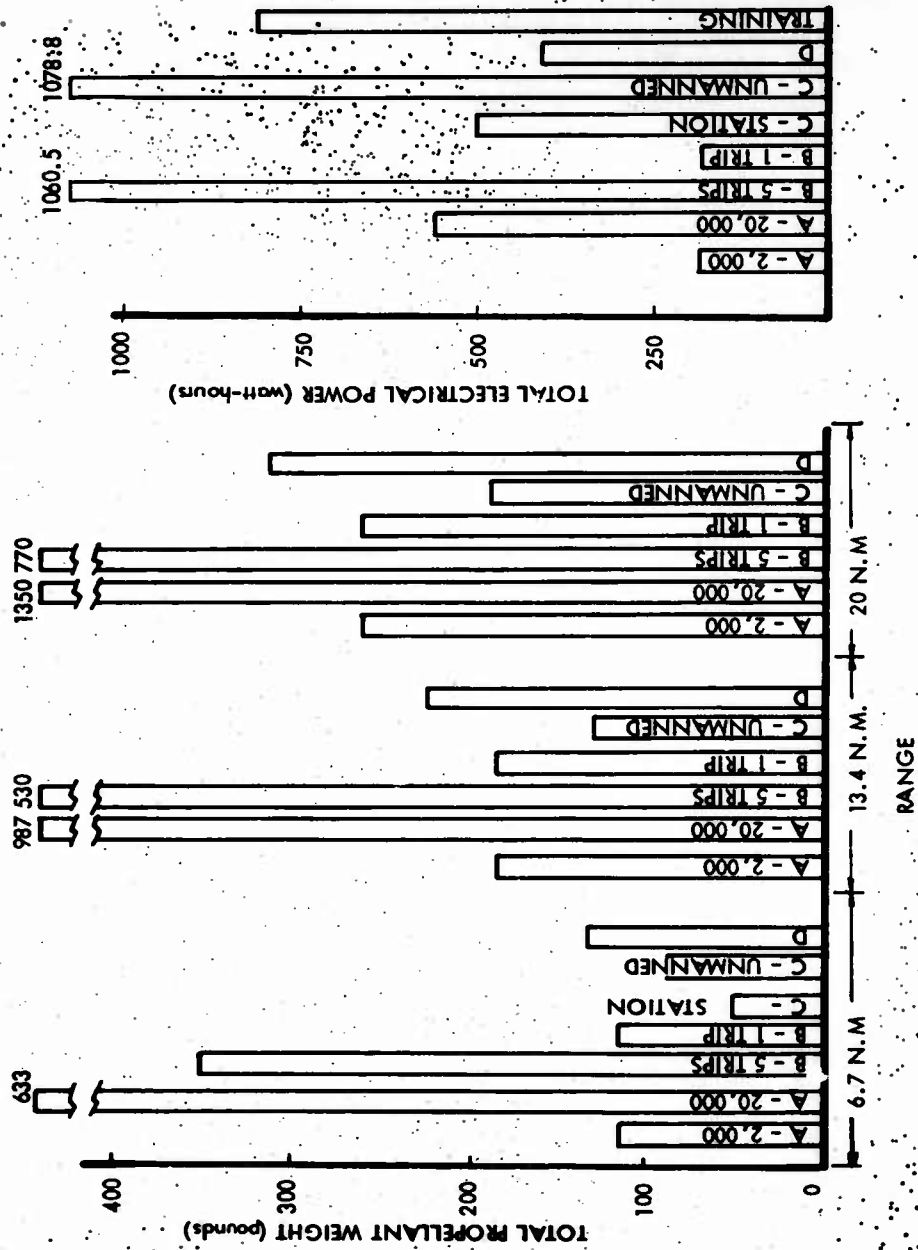

FIG. 1-4 . PROPELLANT AND ELECTRICAL REQUIREMENTS (See Table 1-2 for mission definition.)

1.3.5 Electrical Requirements

The electrical load chart, Fig. 1-4 shows a strong dependence on the type of mission. Twelve hundred watt hours are provided for adequate power. As most of the power is not required for safety of to operate the vehicle, small reserves might appear tolerable; however, to avoid deep discharges and resulting voltage drops, 100 percent reserves on the 1200 watt hours are chosen; making a total of 2400 watt hours available.

1.3.6 Mission Duration

The mission duration for the cases considered is summarized in Table 1-2. Having eliminated the multiple trip missions on the basis of excessive propellant requirements, the maintenance mission dominates. A nominal 5 hours is selected, and reserves for 5 hours are provided. Total life support provisions are then adequate for ten hours, which is considered desirable for tracking and rescue of a lost or out-of-propellant shuttle.

1.3.7 Rendezvous Technique

The guidance technique for shuttle application in Ref. 1-1, Self-Maneuvering Units for Maintenance Workers (SMU) is modified by use of the radar or a visual reference reticle. From a 20-mi. starting range, terminal position errors are reduced from 100 to 20 ft and terminal velocity errors from 20 to 5 fps. The resulting saving in propellant is about 20 pounds taking into account a 5-pound instrument investment for the visual reference. Since the radar weighs only 20 pounds, the weight investment is paid for in a one-way trip. The guidance system for the shuttle consists of a 6-mi. radar with range and range rate displays and a cross-hair type angular reference indicator. For visual reference, a reticle is used which is representative of the radar angular reference indicator. The guidance technique recommended is open loop navigation for ranges extending beyond 6 mi.; and the modified SMU method for terminal maneuvers.

1.3.8 Maintenance Technique Evaluation

An experimental evaluation of several techniques for performing maintenance work from the shuttle was performed as part of the study. A worker in a Mark 4 pressure suit performed several tasks selected from Ref. 1-2 Space

Table 1-2

MISSION DURATION SUMMARY

(In Minutes)

Mission Designation	Mission	Pre-flight	Terminal Maneuver	Outbound Traverse	Inbound Traverse	Terminal Maneuver	Maintenance	Assembly	Total
A	Material Transport 2000 lb	15.6	7.2	10	20	7.2			60
	6700 lb/trip	15.6	7.2	10	40	7.2			80
	20,000 lb/mission (3 trip/mission)								240
B	Personnel Transport	15.6	7.2	20	20	7.2			70
	(5 trip/mission)								350
C	Maintenance-station	15.6					114.7		130.1
	Unmanned satellite	15.6	7.2	20	20	7.2	267.2		337.2
D	Assembly	15.6	7.2	10	40	7.2		60	140

Maintenance Techniques with several arrangements of the shuttle. No attempt was made to simulate weightlessness, as one function of the shuttle is to provide a stable work platform. Necessary restraints were present. Results are summarized in Table 1-3.

Table 1-3
SUMMARY OF CUMULATIVE TASK TIMES
(minutes)

		<u>Replace Gasket</u>	<u>Replace Meteoroid Puncture</u>	<u>Replace Fuel Cell</u>	<u>Replace Damaged Switch</u>
Control Condition	Shirt-Sleeve	19.9	6.1	14.8	8.6
	Unpressurized Suit	38.5	5.5	19.4	10.3
Shuttle With Pressurized Suit	Hatch at 45 Deg	90.0	6.55	37.4	22.7
	Hatch at 90 Deg	86.8	7.2	49.4	26.5
	Fabric Armpieces	Abort	7.55	48.0	34.4

The technique of working inside the pressurized capsule when the size of the part to be maintained permits, or working through a mating hatch in a pressurized target, are similar so far as the worker is concerned. The test results shown for a worker in an unpressurized suit, are therefore applicable to both of these cases.

The shelter technique, designed to allow the worker to perform effectively while retaining the major protective advantages of the shuttle, is represented by the test results with the hatch in the 90-deg and the 45-deg positions. The shelter provides a retaining compartment for loose pieces as well as providing meteoroid protection and control of the thermal environment.

The objections to exposing the worker to a vacuum are overcome by use of the sleeve technique in that the worker need not wear a pressurized suit and, is therefore more comfortable and less fatigued. However, the work is still done by the operator's hands which are enclosed in pressurized gloves. The limited mobility of the worker requires that the entire shuttle be easily shifted with respect to the work and rapidly locked in place. Either an external storage area for tools and spare parts that the worker can reach with the sleeves, or a small airlock through which he can pass objects is necessary. Specific difficulties encountered with the sleeves include: the using of both hands simultaneously, seeing objects worked upon, and handling bulky objects whose dimensions approach the length of the worker's arms.

A natural approach to overcoming the reach and mobility restrictions of the sleeves, while retaining the protective features of completely enclosed pressurized worker, is to provide mechanical devices to do the exterior job while the worker remains in the shuttle. In reviewing the specific operations required of the shuttle operator, it is found convenient to classify the manipulator requirements encountered into four groups. These are defined in Table 1-4, which gives the characteristics, the expected application and the number required per shuttle. The types it is seen, proceed from those intended to handle the complete vehicle, to those that handle large components, to the two types for performing small precise operations. With these broad applications in mind, the manipulators available were surveyed. In general, the weight and power requirements are disappointingly high, and the load and dexterity capabilities disappointingly low.

The most natural approach to the design of a multi-purpose manipulator is to imitate the human hand thereby making use of existing tools and techniques possible. However, the classification of manipulator characteristics suggests that manipulators designed especially to work in conjunction with satellites and tools designed for this specific purpose may be more successful than the anthropomorphic approach.

Table 1-4

MANIPULATOR REQUIREMENTS

Type	Characteristics	Application	Number per Shuttle
Grapple	Quick attach - release to cooperative and uncooperative targets. Position control.	Docking, alighting and towing cargo	3
Holst	Payload grips, precise positioning of objects about shuttle, stiff, high load capacity.	Handle payload, e.g. fuel cells, perform mating in assembly mission	2
Forceps	Grip and precise positioning of small components, e.g. nuts, bolts, electronic components, covers. Long reach, small envelope.	Position and retain components	2 plus numerous heads
Torquer	Flexible shaft driven socket, Allen, etc., wrench. Oblique and 90 deg heads, plumbing electrical disconnect attachments interchangeable. Long reach, small envelope.	Use on mounting bolts of fuel cell, on gasket change parts, etc.	1

1.3.9 Preliminary Design

The general arrangement of the trainer version is shown in Fig. 1-5, an inboard profile of the operational version in Fig. 1-6, and a weight statement in Table 1-5. Salient features are:

- Adaptability to alternate missions by installing appropriate forward shells; all basic systems are installed in the aft shell
- One-man crew with space for one passenger
- Docking hatch to fit Apollo-Gemini-type receptors
- Space, weight, and power, adequate for tools, spares, and checkout equipment
- Shelter for exterior maintenance work
- Grapplers capable of alighting on cooperative and uncooperative targets, the handling of cargo and in-space assembly modules
- Overall dimensions
 - Height: 92.9 in.
 - Width: 89.0 in.
 - Length: 73.0 in.
- Internal volume: 95 cu ft

Principal features of the subsystem are:

Propulsion

Fuel: 50-50 UDMH - Hydrazine

Oxidizer: N_2O_4

Feed system: Pressure fed, dual bladders, N_2 pressurant

Main propulsion: 16 thrusters, of 25 lb thrust each

Pitch and yaw control: main thrusters

Roll, side and vertical translation: 8 thrusters of 5 lb thrust each

Nozzle: radiation cooled, expansion ratio 40

Engine control: pulse width modulation

Environmental control

Atmosphere: pure oxygen

Pressure: 3.5 to 5.0 psi

Table 1-5

WEIGHT SUMMARY
(pounds)

Item	Maintenance Mission	Training Mission
Structure	238	166
Mechanical	58	41
Environmental control	88	64
Electrical power supply	87	53
Attitude control	87	77
Main propulsion	128	128
Communication and navigation	44	44
Miscellaneous	44	19
Contingency	23	18
Dry Weight	<u>797</u>	<u>610</u>
Propellant	270	65
Oxygen and water	37	25
Tools, spares, test sets	160	---
Gross Weight (Less Crew)	<u>1264</u>	<u>700</u>

CO₂ removal: LiOH

Heat rejection: water boiler.

Electrical Power

Silver-zinc batteries

1.3.10 Problem Areas

Although the design of the shuttle vehicle presents no critical technical problems, problem areas do exist with regard to the techniques, equipment, and satellite design to enable effective maintenance, checkout and repair operations. Specific items which require improvement in design are space suits, tools, and manipulators which will permit effective work without exposing the operator to

the space environment. An integrated approach to the design of satellites for maintenance, the design of tools, and the design of manipulators is desirable.

Techniques and devices for the handling, packaging, stowage and protection of cargo also present a problem area. A primary requirement is for standards applicable to earth-to-orbit ferry vehicles, space-based vehicles, and the shuttle.

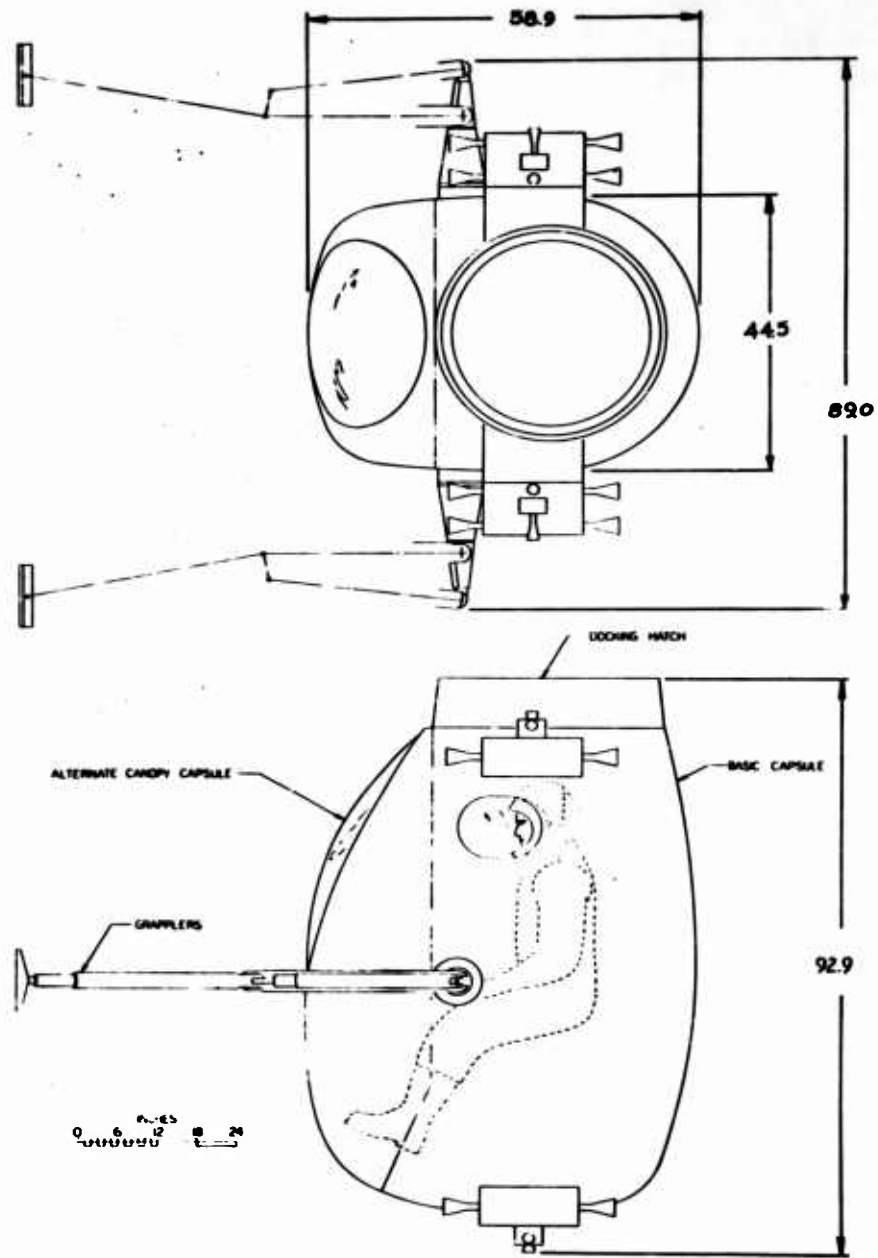
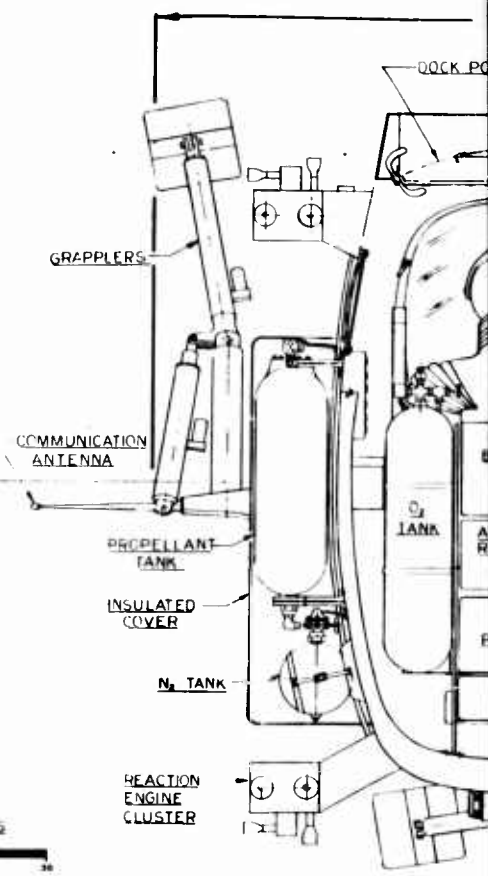
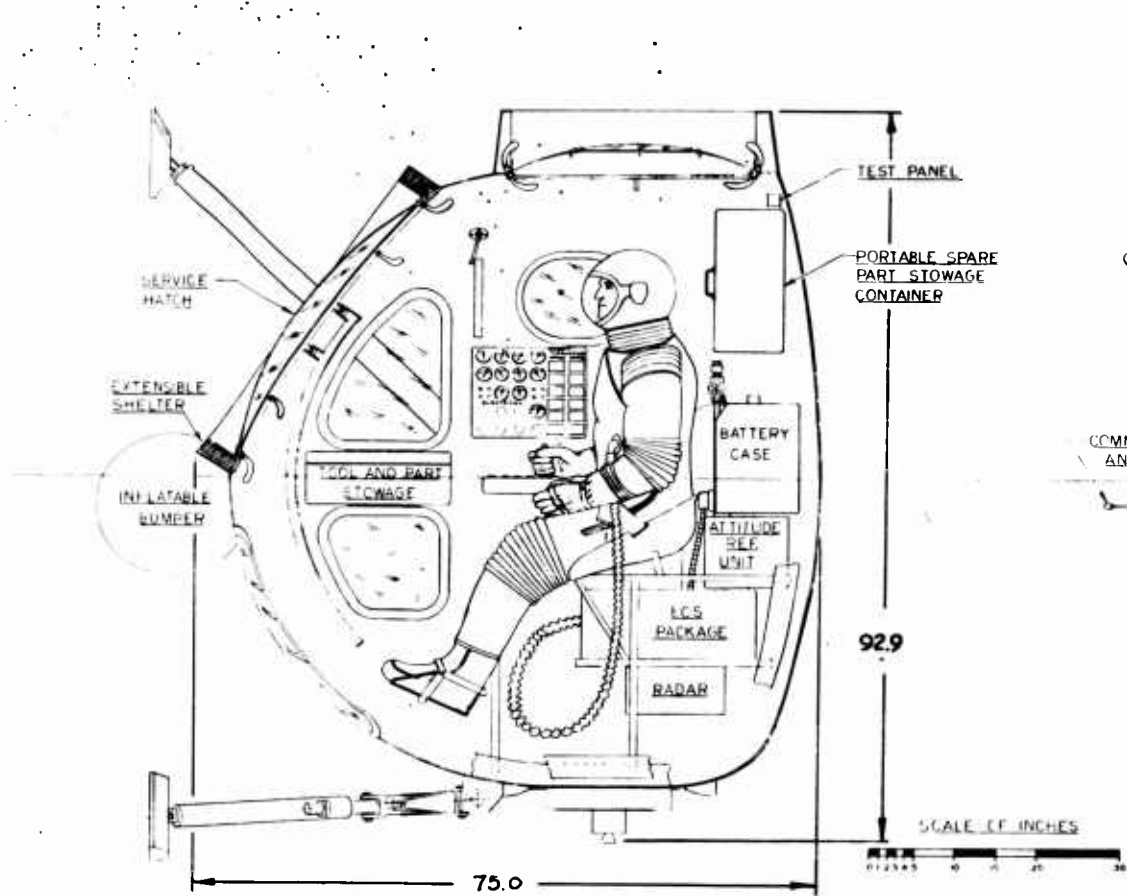

FIG. 1-5 SHUTTLE TRAINER ARRANGEMENT



1

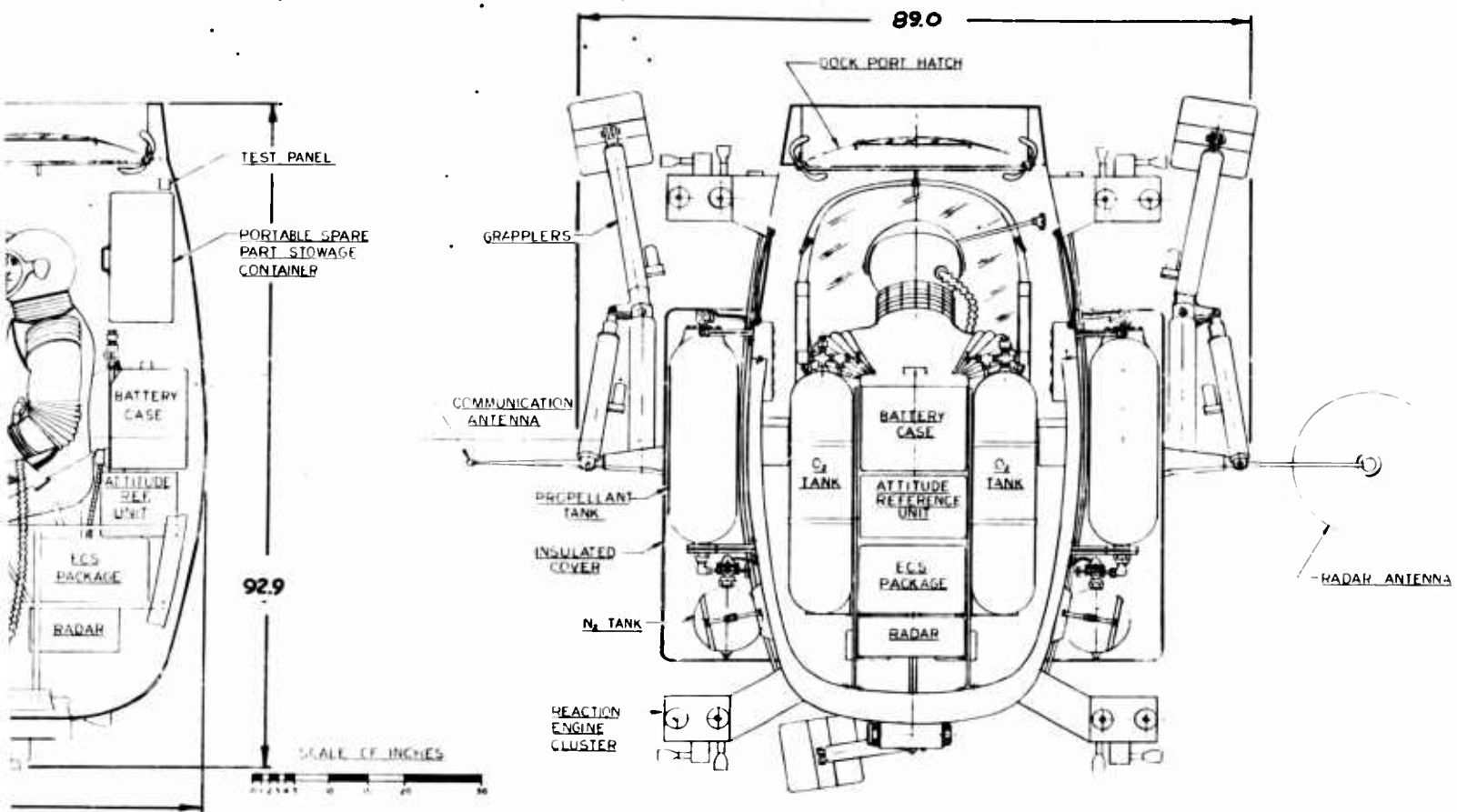

FIG 1-6 SHUTTLE INBOARD PROFILE

1

2

Section 2
MISSION DEFINITION

2.1 SPACE SYSTEMS DEFINITION

The space systems expected to be in operation during the period considered for the shuttle are identified in this section. The pertinent programs that have been undertaken in the past, existing programs, and those proposed, are listed in Tables 2-1, 2-2, and 2-3. The inferences drawn from these data are discussed below.

Table 2-1 lists the launch vehicles and their growth capabilities, as they supply the key to the other aspects of the space endeavors. Three general eras are apparent. The first includes all those boosters up through the Atlas and culminates in the ability to orbit the one-man Mercury at low altitudes. The second group of boosters includes versions of the Saturn and the Titan. These will be available in the near future and offer the capability of placing loads as high as 200,000 lb in near-earth orbits. The third group, including the Nova recoverable boosters, airbreathing, and nuclear types, are not expected to be in operation for about ten years, but will introduce the capability of ambitious missions at a reasonable cost.

Table 2-2 lists the manned spacecraft expected to be in operation in the next ten years. These fall into three groups analogous to the three booster groups. The first group includes the one-, two-, and three-man vehicles intended primarily for space experimentation and exploratory work. The second group, which exploits the larger booster capabilities, includes permanent space stations manned with crews of two- to three-dozen men. Supporting these stations are the supplementary missions of resupply, maintenance, and assembly. The third set of manned spacecraft comprises those large stations designed for specific military or commercial purposes,

other than experimentation, in near-earth orbits. The experimental work at this time will have progressed to the Moon and planets. Unmanned

Unmanned spacecraft are listed in Table 2-3. A multitude of satellites, purposes and orbits are shown. While some of these missions will probably disappear in time, it is expected that others will appear to replace them. Certain trends are apparent. First, there has been a steady increase in the size of the payloads as booster capability has increased; second, the diversity of orbits has increased. However, there are several groups of favored orbits; polar, synchronous, and those with an inclination of 45 to 50 degrees.

In summary, it appears that the space systems existing concurrently with the shuttle will be based on booster capabilities of 20,000 - 40,000 lb in orbits, with the Saturn V capability of 200,000 lb available for special occasions. There will be experimental manned flights in small spacecraft for approximately five years, then permanent stations growing to complex multi-purpose satellites in about ten years. At the same time, numerous small, unmanned vehicles will exist in many special orbits. Although these vehicles will have a variety of sensing equipment, all will have data handling, transmission and control capabilities.

**TABLE 2-1
LAUNCH VEHICLES**

<u>Vehicle</u>	<u>Availability</u>	<u>Payload Capability In Near-Earth Orbit</u>
Thor-Able Star	Current	Under 1000 lb
Thor Agena	Current	Under 1000 lb
Atlas	Current	{ 1000 to 10,000 lb
Atlas Agena	Current	
Atlas Centaur	Current	
Titan II		
Titan III A (II + Transtage)		
Saturn I (S-I, S-IV, S-V)	1965	{ 20,000 to 40,000
Saturn I (S-I, S-IV)		
Saturn IB (S-I, S-IVB)		
Titan III B (II + 2 Solids)		
Ten Passenger Carrier	1972	
Saturn V (S-IC, S-II, S-IVB)	1965	Over 200,000

Table 2-2
MANNED SPACECRAFT

Vehicle	Crew	Weight		IOC
Mercury	1	3,000	1962	Program complete
Gemini	2	7,200	1964	
Apollo	3	10,000	64-65	
	3		66-67	Lunar orbit
			67-68	Lunar landing
Lunar Excursion Module (LEM)	1	24,000	1966	First manned flight
X-20 Dyna-Soar	1	12,000	1964	
<u>Space Stations</u>				
MODS Manned Orbital Development System	4-6	20,000	1968	In-space assembly may be considered for polar orbits
NASA-Manned Orbital Research Laboratory	4-6	20,000	1966	
NASA-Large Station	18-30	175,000	1970	
Manned Surveillance Command and Control Station			1970	
ESWS Earth Satellite Weapon System				
Lunar Base Interplanetary				

Table 2-3

UNMANNED SPACECRAFT

PROGRAM	Number of Satellites	IOC	Size (lb)	Orbit Incl. (deg)	Apogee (n. mi)	Mission
Earth Orbit Data - Gathering and Communications						
Topside-Sounder	1	63	90	80	540	Scientific circular orbit
Polar Ionosphere Beacon	1	62	90			Scientific
SERT	2	63	70	90	600	Ion engine test
Explorer 16	2	63	320			Micro meteoroid test
ARIEL	1	62	159	52	640	Scientific
BIOS II	2	62	150			Biological test
Transit 5A	7	64				Navigation
Anna IB	5	62	135	90		2 per yr after '63
Tiros 4	6	62	355	50	640	Goedetic
5	1	62	285	48.3	460	Weather
6	1	62	281	58.1	525	"
7 - 16	1	62	285	58.3	384	"
Relay	10	63				
	3	62	172	48.3	3,000	Communication

Table 2-3 (Continued)

PROGRAM	Number of Satellites	IOC	Size (lb)	Orbit Incl. (deg)	Apogee (n. mi)	Mission
Explorer 17	4	63	405		325	Scientific
1-27 Syncom MK I	3	63	125		19,400	Communication
TELSTAR I	1	62	170	45	2,400	"
2	1	63		45	5,200	"
IMP 1 - 7	7	63	60		150,000	Scientific
OSO	8	62	350	33	325	Solar research
Pioneer	7	64	120			"
Explorer 14	4	62	89	36	46,000	Scientific
Explorer 15	1	62	311	18	41,000	Scientific
ECHO I	12	62			830	Communications
2	1	63	500	90	600	"
Alouette	1	62	320	80.5	555	Scientific
Nimbus	9	63	650	90	500	Meteoroid
Ogo-Pogo	4	64	1000	90	500	Geophysical observation
Ego	9	63	1000		58,000	Astronomical observatory
OAO	5	64	3300			Communications
Syncom 2	3	64	500	0		Solar observatory
Helios	1/yr	66	1017			

Table 2-3 (Continued)

PROGRAM	Number of Satellites	IOC	Size (lb)	Orbit Incl. (deg)	Apogee (n. mi.)	
Advanced OAO		67	4000		23,400	Astronomical observatory
CSAR		65	4000		19,400	Communications
Aeros		66	1000	0	19,400	Meteorological
Arents	3				19,400	Environmental test
Rebound	6	64			1,500	Communication
Comsat	24-36		150	90	10,000	"
	3-10	64	500	0	19,400	"
Earth Orbit - Military Lunar and Interplanetary Orbit						
Ranger			750			Lunar impact
Surveyor	9	64-66	2000			Lunar exploration
Prospector						"
Mariner		62-64				Venus and Mars fly-by

2.2 SPACE SYSTEM - SHUTTLE INTEGRATION

Specific space systems resulting from the integration of the shuttle into the early systems identified in para. 2.1 are described in the following. Characteristic data, modes of operation, and the functions performed by the shuttle are presented. These data form the basis for the definition of design missions in para. 2.3, and the trade-off study of para. 3.1. The systems are described in the order in which they are expected to become operational.

2.2.1 Gemini and Shuttle

The objectives of the Gemini program are space experimentation and personnel training. Ten experiments of particular interest to the Air Force have been identified:

- Visual definition of objects in space
- Angle-track-only rendezvous guidance
- Cooperative target inspection
- Hybrid IR/laser guidance equipment
- Passive infrared star and satellite tracking
- Extravehicular operations
- Autonomous navigation
- Observation of missile launches
- Visual definition of terrestrial features
- Radiation levels within the space capsule

The first seven experiments involve relations between vehicles, maneuvering or extravehicular operations. The shuttle is considered in conjunction with Gemini to enable performance of these experiments under controlled conditions, as well as experiments involving crew performance. Such experiments include docking techniques, material handling, maintenance equipment, and techniques.

The shuttle would be stowed in the Gemini booster adapter for launching, requiring the shuttle crewman to leave the Gemini to enter the shuttle. Although the shuttle could be moved mechanically to a position adjacent to the Gemini hatch for the transfer, exposure to vacuum would still occur unless a mating hatch is fitted to both vehicles. As experiments in space suits are also planned as part of the Gemini program, the weight increment for mating hatches and repositioning gear is not included in this study.

Weight data used for this study are:	<u>pounds</u>
Gemini Weight in orbit	7000
Maneuvering propellant available	700
Experimental equipment weight available	700

2.2.2 Apollo and Shuttle

Apollo vehicles in near-earth orbits could perform experiments similar to those discussed for Gemini, but it is anticipated that the Apollo flight program will be used specifically for the development and checkout of equipment for the lunar mission. Use of the shuttle in combination with the Apollo system would be effective as a lunar surface exploration vehicle and as a back-up vehicle for the lunar orbit rendezvous operation. Early mapping of the moon may also be facilitated by use of the high mass ratio available in the shuttle vehicle, as a plane change of approximately 15 degrees would be available in lunar orbit for departing from and returning to the command module. A precise analysis of the integration of the shuttle into the Apollo system is beyond the scope of this study, but the shuttle might prove to be a valuable adjunct to the Apollo.

2.2.3 Small Space Station and Shuttle

Two small space stations are defined using data from Lockheed-California Company in-house studies. These are typical of the early stations being considered.

These stations are cylindrical, modular configurations, and both use a ferry spacecraft for crew rotation and emergency escape. Configuration A uses fuel cells for on-board power while configuration B uses solar cells; the marked difference in resupply requirements, as shown in Fig. 2-1, results mainly from the fuel cell fuel requirement.

Gravity simulation is provided by a mass-and-cable technique as the stations are too small to effectively use rotation about their own center of gravities. Hatches similar to those being considered for Apollo vehicles are provided for use with the earth-to-orbit ferry vehicle. These hatches are also suitable for parking, loading, and unloading the shuttle.

<u>Station Weight (pounds)</u>	A	B
Station Weight	15, 171	17, 248
Supplies (30 days)	4, 359	2, 244
Earth-to-Orbit Ferry (s)	9, 400 *	21, 618 **
Radiation Protection	2, 560	2, 560
Adapter	<u>1, 060</u>	<u>1, 280</u>
In-Orbit Weight	32, 550	44, 950

*One six-man ferry; **3, 2-man ferries

<u>Resupply Requirements for Six-Man Crew lb/day</u>	A	B
Fluid and Tankage	87.8	15.8
Propellant	10.4	10.9
Life Support	27.1	28.1
Spares, Experimental Equipment	<u>20.0</u>	<u>20.0</u>
	145.3	74.8

2.2.3.1 Test Operations

The use of the shuttle with the small space station extends the programs described for Gemini. Experimental work performed by the shuttle

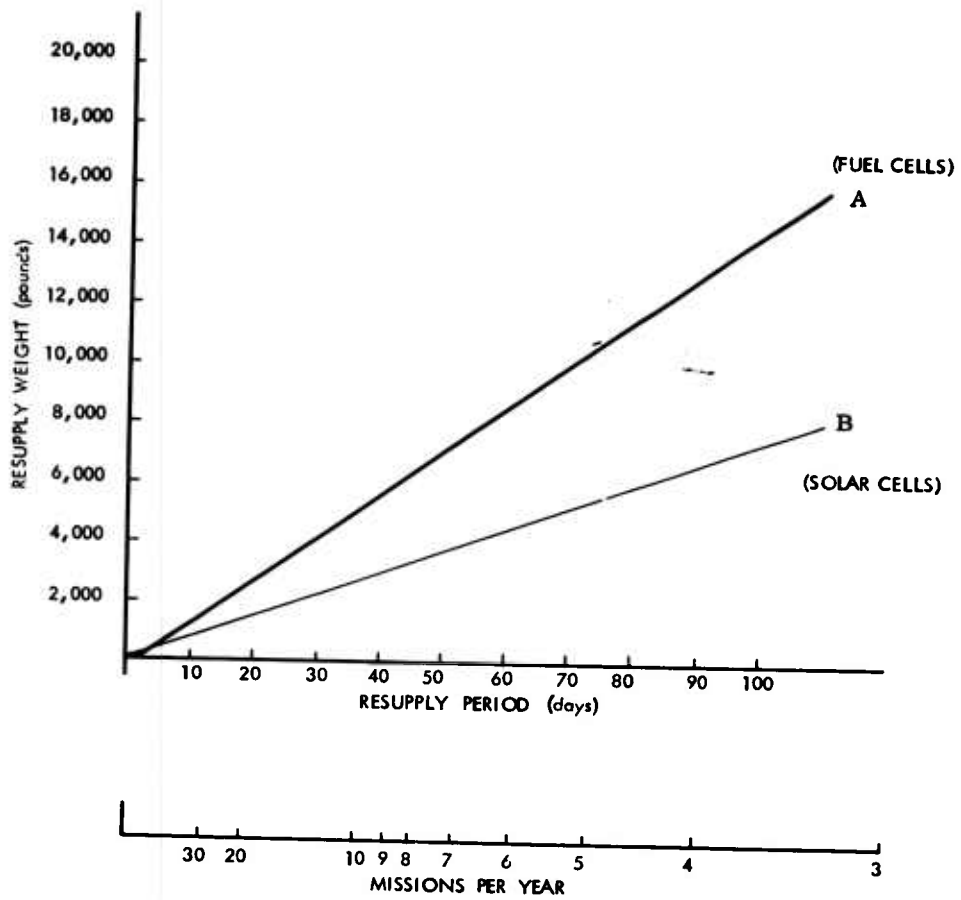

FIG. 2-1 SIX-MAN STATION - RESUPPLY

includes personnel training and tests, research and development on equipment, and data gathering for various scientific experiments.

2. 2. 3. 2 Station Assembly

It is planned to boost small space stations into orbit pre-assembled. The design, however, incorporates modular features which permit expansion of the station as additional modules are available. The shuttle may be used for retrieving and positioning the added modules, for bringing the man to the assembly point, and for supplying the tools and power required for the assembly operations.

2. 2. 3. 3 Resupply Operations

The resupply may be accomplished in one of the following five ways:

- The resupply module is launched with a manned module carrying the replacement crew. This crew flies the combined modules to the station after injection into orbit.
- Supplies are launched in an unmanned module containing the necessary propulsion, attitude control, and command systems necessary for the station crew to guide the module to the station by remote control.
- The station flies to the supply module after it is injected into orbit.
- The emergency escape module present on the station is used to retrieve the unmanned supply module.
- The shuttle retrieves the supply module.

2.2.4 Large Space Station

The characteristics of a large space station are taken from Ref. 2-1, Operational Feasibility of a Conceptual Large Space Station. This station is a hexagonal structure, 120 ft in diameter. Each side of the hexagon is a cylinder 10 ft in diameter which may act as a self-contained unit. A central hub used for docking and parking the earth-to-orbit ferries is connected to the ring by three spokes, each a cylinder 5 ft in diameter. An angular velocity of 4 rpm, providing a simulated gravity of approximately 1/3 g is anticipated.

<u>Station Weight</u>	<u>pounds</u>
Station weight at launch	151,990
Launch escape system	5,800
Command vehicle	15,900
Adapter	11,000
	<hr/>
	184,630

Resupply Requirements for 21-Man Crew, 45-Day Supply

	<u>Weight (lb)</u>	<u>Specific Gravity</u>	<u>Vol (cu. ft.)</u>
Food	1420	0.5	44.5
Water	380	1.0	6.1
Oxygen (non-regenerative)	3600*	1.15	50.0
Nitrogen	1300	0.82	25.4
Propellants	1900	1.25	24.4
Miscellaneous (100 lb day)	4500	0.3	240.0
	<hr/>		<hr/>
	13,100*		390.0

* 3000 lb can be saved with oxygen regeneration

Simultaneous crew rotation and resupply of this large station using the Saturn I and Saturn I-B have been studied; the results are shown in Figs. 2-2 and 2-3. As in the case of the small station, subsystem design has a powerful influence on the resupply requirements. In this case, the effects of four methods of oxygen resupply are shown.

The shuttle functions in conjunction with the large station are similar to those described for the small stations. The size and mechanical complexity of this station with its joints, solar arrays, hub and propulsion systems not accessible from the inside, result in greater emphasis on shuttle use for maintenance. Although this particular station is designed to be launched as a unit and to be mechanically deployed, a space assembly mission is considered for the shuttle for extending the capability of the station and for erecting stations of other configurations.

2.2.5 Multiple-Manned Systems

As space operations develop, a number of systems will be in operation simultaneously. Shuttle missions involving two manned systems are described in Table 2-4. In this table, the vehicle permanently stationed in orbit, or the larger of two permanent vehicles, is designated "Primary", the other vehicle is designated "Secondary". Weights shown are typical values for the class.

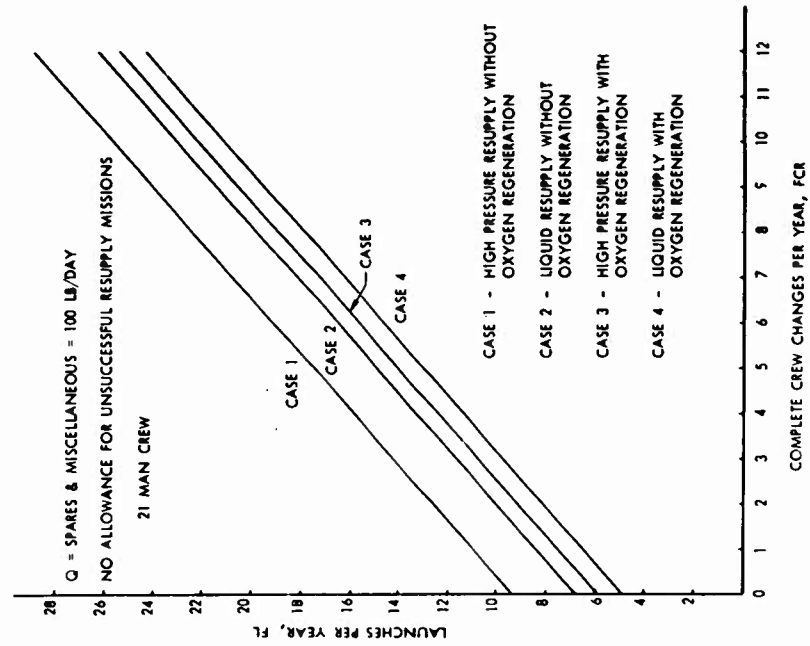

FIG. 2-3 REQUIREMENTS FOR RESUPPLY LAUNCHES, SATURN C-1

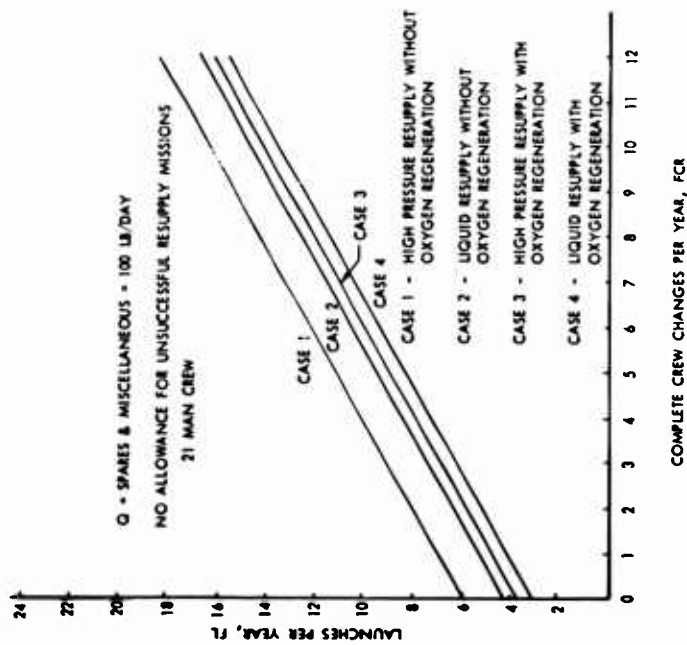

FIG. 2-2 REQUIREMENTS FOR RESUPPLY LAUNCHES, SATURN C-1B

Table 2-4

SHUTTLE MISSIONS WITH TWO MANNED VEHICLES

Primary	Secondary	Shuttle Function	Shuttle Payload
Space Station 150,000 lb	Space Station 30,000 lb	Transfer men and material	6 men or 6000 lb
Space Station 150,000 lb	Recoverable booster or 10-passenger carrier 100,000 lb	Transfer men and material	10 men or 20,000 lb
Space Station 30,000 lb	Manned maneuverable vehicle, e.g. X-20 15,000 lb	Rescue	One man

Payload for the first case is selected by assuming: (1) that the small station is being abandoned and that the entire crew is transferred to the large station, or (2) that the small station is being resupplied from the large station stores.

The second case is the normal resupply of a large space station by a manned, recoverable ferry.

The third case represents a small manned vehicle which normally returns to the earth unaided after completing its mission, but which has encountered some difficulty, requiring the crewman to be transferred to the space station.

2.2.6 Space Stations and Unmanned Satellites

A space station in conjunction with the shuttle is considered as a maintenance base for servicing the unmanned satellites listed in Table 2-3. Although over forty programs are listed which involve approximately 200 satellites, most of the maintenance tasks encountered by the shuttle can be classified as:

Sensors

Radar

IR

Photographic

Ferret

Optical

Radiation

Communication

Electrical Power

Stabilization and Control

Guidance

Propulsion

Of the forty-plus types, only four of 1000, one of 3300, and two of 4000 lb weight are listed. While a greater number of heavy satellites are expected in the future, it is evident that the bulk of the work that may be accomplished by unmanned vehicles, may be done by vehicles of 500 lb or less. The weight distribution of future unmanned satellites used in this report for evaluating shuttle missions is:

	<u>Percent</u>
Over 5000 lb	3
1000-5000	7
500-1000	10
Under 500	80

As space stations become more numerous, many of the missions now performed by unmanned satellites may be done by the stations or by shuttles, but an appreciable transitional period is anticipated.

A successful repair mission requires that the malfunction be identified, that the worker have access to the damaged part, and that the working conditions allow the worker to: exercise the necessary dexterity, see the work objects, position the tools, and check out equipment and spare parts as required. The operation of the shuttle for repair of unmanned satellites allows the worker a choice of performing the repair on the part located in the satellite, of bringing the part (or the entire satellite) inside the shuttle, and of transporting the faulty component to the primary for repair. Another alternative could be provided by designing the target satellite and the shuttle with mating hatches and with pressurized areas large enough to enable the worker to operate at the site, but with the benefits of a pressurized environment and controlled lighting.

2.2.7 Interplanetary and Lunar Missions

The function of the shuttle in manned missions beyond near-earth orbits is similar to that with near-earth space stations. Specific shuttle activities are:

- Assemble vehicle and boosters
- Assist in refueling operations
- Transfer men and material between vehicles of a fleet
- Conduct surface and orbital exploration of members of the solar system.

Assembling an S-IV stage weighing 117,000 lb is taken as a typical task for the shuttle in this mission.

2.3 SUMMARY - MISSION DEFINITION

Although the space systems described in para. 2.2 differ widely in their purposes and in the vehicles employed, the functions of the shuttle are similar in many cases. These common factors are used to define six design missions as shown in Table 1-1. Use of these design missions, rather than the set of space systems, simplifies the following discussion and directly relates the shuttle characteristics to the governing function.

Section 3

SHUTTLE CONCEPTS ANALYSES

3.1 SYSTEM TRADE-OFFS

The relationship between the shuttle and the complete space system within which it operates is discussed herein. The regions of applicability of the shuttle and those factors which govern the choice of mission parameters and major design features of the shuttle are presented. The trade-offs in overall system cost for various modes of operation with and without the shuttle are considered in para. 3.1.1. The effect on mission parameters of variations in the propulsion system is evaluated in para. 3.1.2, and in para. 3.1.3 the effect of maintenance equipment provided in the shuttle on the probability of mission success is evaluated. Results are summarized in para. 3.1.4.

3.1.1 Cost Effectiveness of Shuttle

Isolating the difference in total system costs produced by introducing the shuttle is difficult because the shuttle is small and minor variations in system operation mask the shuttle effects. The small size of the shuttle, which in turn requires small amounts of propellant for a given velocity change, suggests the basis on which to evaluate the use of the shuttle. Each sortie of the shuttle represents a savings in propellant over using the primary vehicle for the same purpose. After a certain number of missions, the cost of the shuttle is balanced by the savings in the propellant. The number of missions at which the cost of the system without the shuttle equals the cost of using the shuttle, is a convenient measure of its value. The fewer missions required for equal-cost the more advantageous is the use of the shuttle.

Both economical and technological factors change rapidly. To present data of some general applicability, relationships in terms of launch costs

(dollars/pound in orbit), hardware cost, and propellant cost are presented. These general data are then applied to the specific cases identified in section 2.2 to illustrate the utility of the shuttle in typical applications.

The cost effectiveness study of this section postulates a space system consisting of a primary vehicle, a target vehicle in a slightly different orbit, and a requirement to transfer a payload from the target to the primary. This model may represent the resupply of a space station with unmanned cargo carriers by regarding the station as the primary and the cargo as the target.

Applied to repair and maintenance missions, the base from which the shuttle operates is the primary, the object requiring repair is the target, and the payload consists of the crew, tools and spare parts. Two modes of operation are considered: a primitive mode in which the primary makes a one way trip to the target, and a shuttle mode in which the shuttle proceeds from the primary to the target and returns to the primary with the desired payload. A comparison of the two modes is first made on the basis of total mass placed in orbit. A cost comparison is then made recognizing the different values of shuttle hardware and of propellant. The results are presented in general form and may be used to compare the effectiveness of two vehicles performing a specified maneuver. The general results are applied to the specific systems defined in Section 2.2.

3.1.1.1 Weight-In-Orbit Comparison

The primitive mission is defined as one which requires the primary to execute one maneuver with a characteristic velocity, ΔV . The shuttle mission requires two maneuvers of the same ΔV , the second carrying the payload. The primary and the shuttle are assumed to use the same propellants and to require the same mass ratio for the given ΔV . The effect of thrust-to-mass ratio is discussed in paragraph 3.1.1 and is assumed to be the same for primary and shuttle vehicles. The effect of attitude control propellant is included as a constant percentage of the maneuvering propellant required. The same constant is used for both primary and shuttle. Treating these two effects as constants is

conservative (i. e. , reduces the advantage shown for the shuttle), for primaries with small maneuvering engines and high moments of inertia.

As shuttle components such as thrust chambers, expulsion bladders, and batteries have limited lives, and as spares are required to maintain operations while repairs are being made to malfunctioning and accidentally damaged parts, the shuttle operation is charged with a refurbishing hardware weight in orbit. The shuttle refurbishing factor is defined as:

$$k_r = \frac{\text{Empty weight} + \text{spare parts weight}}{\text{Empty weight}}$$

This is applied as a multiplying factor to the shuttle weight placed in orbit.

The shuttle may be used for many purposes once on station. To avoid placing the entire burden of shuttle cost on each mission investigated regardless of its importance, a shuttle utilization factor, k_u , is introduced:

$$k_u = \frac{\text{Shuttle costs borne by mission in question}}{\text{Total shuttle cost}}$$

Defining:

MR	Mass ratio = $\frac{\text{Vehicle} + \text{payload} + \text{propellant weight}}{\text{Vehicle} + \text{payload weight}}$
N	Number of missions to be performed
W_{st}	Total weight charged to shuttle
W_s	Weight of shuttle vehicle
W_{ps}	Weight of shuttle propellant
W_p	Weight of payload including 2 (crew weight) as crew goes both ways
W_{sta}	Weight of primary
W_{psta}	Weight of propellant used by primary
k_r	Shuttle refurbishing factor

k_u	Shuttle utilization factor
k_a	Attitude control propellant factor
M	$N(MR-1)$ = Mission characteristic
R_s	$\frac{W_s}{W_{sta}}$
R_p	$\frac{W_p}{W_{sta}}$

The weight in orbit charged to the shuttle consists of:

- | | |
|--|------------------------------|
| 1. Shuttle weight | $k_r k_u W_s$ |
| 2. Propellant for shuttle round trip | $2 W_s N k_a (MR-1)$ |
| 3. Propellant for payload one way | $W_p N k_a (MR-1)$ |
| 4. Propellant to carry items (2) and (3)
on the outbound trip | $(W_s + W_p) N k_a (MR-1)^2$ |

The propellant terms are approximate, but, for the small ΔV s considered, even the last term is negligible, and a sufficiently precise relationship is

$$W_{st} = k_r k_u W_s + N k_a (MR-1) (2 W_s + W_p) \quad (1)$$

The only weight in orbit charged to the primary is for propellant one way

$$W_{psta} = N (MR-1) W_{sta} k_a \quad (2)$$

The usefulness of the shuttle in specific instances may be evaluated by calculating $(W_{st} - W_{psta})$. However, a more useful relationship is found by determining the equal cost point, i.e., setting

$$k_r k_u W_s + N(MR-1) k_a (2 W_s + W_p) = N(MR-1) W_{sta} k_a$$

The term $N(MR-1)$ is a measure of the frequency and difficulty of the mission and is conveniently expressed in terms of the relative vehicle weights by dividing by W_{sta} :

$$k_a M = k_r k_u R_s + k_a M [2R_s + R_p] \quad (3)$$

$$M = \frac{k_r k_u}{k_a} \frac{R_s}{1 - (2R_s + R_p)}$$

Values of the mission characteristic, M , at the equal cost point are shown in Fig. 3-1 for

$$\frac{k_r k_u}{k_a} = 1.$$

To facilitate use of the equal cost chart, the values for M for various values of mass ratio and number of missions are shown in Fig. 3-1. A scale of characteristic velocity corresponding to the mass ratio and an I_{sp} of 310 sec is also shown for convenience.

The effect of increasing the factor $\frac{k_r k_u}{k_a}$ is to move the curves to the right, thereby reducing the region of profitable shuttle operation. Both k_r and k_a are always greater than 1, and typical values for both are expected to be in the neighborhood of 1.25. The utilization factor is unity for single purpose shuttles, and it decreases as additional functions are added to share the cost. The chart based on $\frac{k_r k_u}{k_a} = 1$ may, therefore, be used directly for first estimates.

3.1.1.2 Cost Comparison

The Equation (3) is based on weight in orbit and ignores the disparity in first cost of propellant and hardware. Introducing the cost/lb:

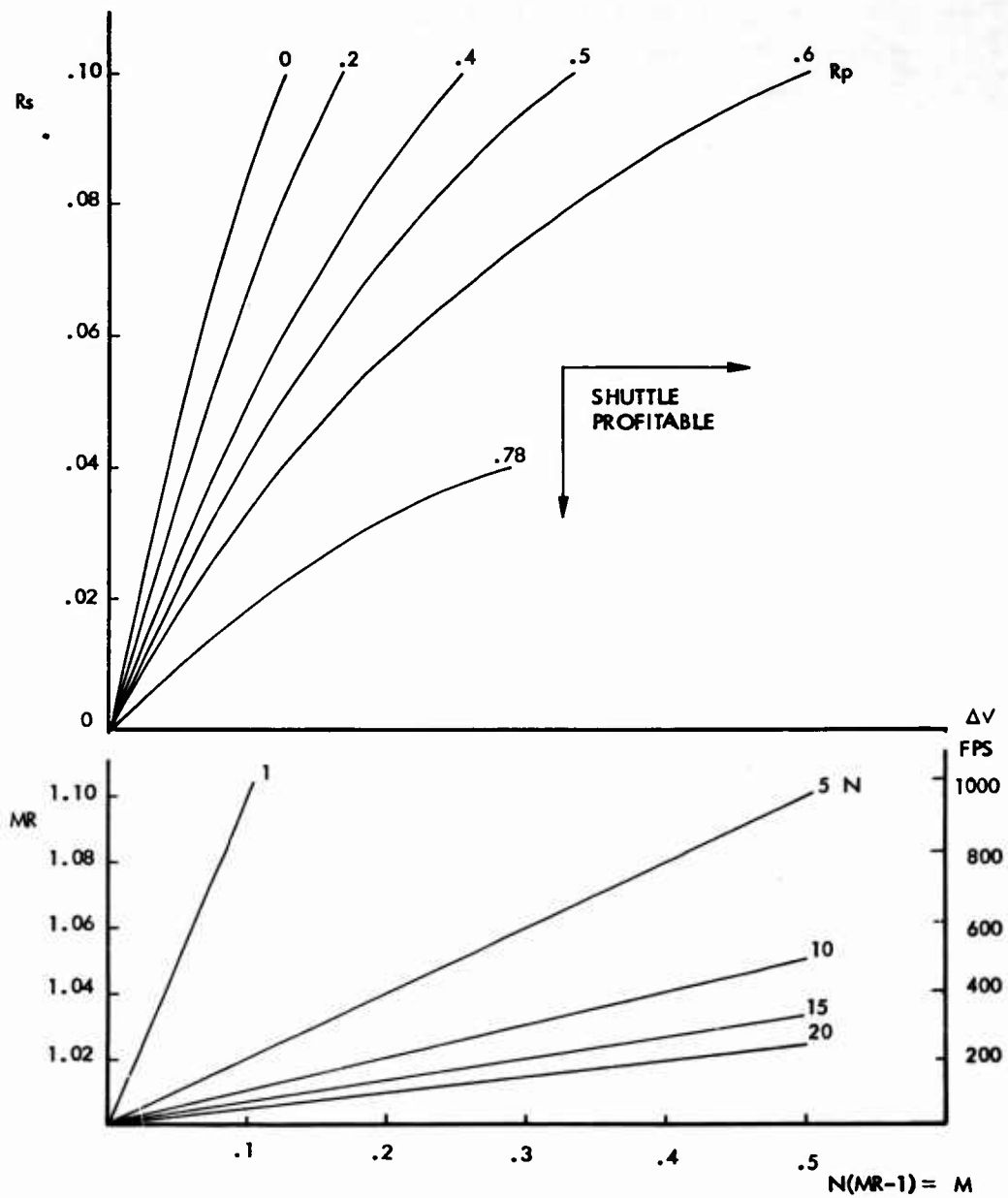

FIG. 3-1 PRIMITIVE VS SHUTTLE OPERATION, EQUAL - COSTS BASED ON WEIGHT IN ORBIT

C_l = launch cost \$/lb in orbit

C_p = propellant cost \$/lb = negligible

C_h = hardware cost \$/lb

Cost of primary propellant = $(C_l + C_p) N (MR - 1) W_{sta} k_a$

Cost of shuttle hardware = $(C_l + C_h) k_r k_u W_s$

Cost of shuttle propellant = $(C_l + C_p) k_a N(MR - 1) (2W_s + W_p)$

Equal costs of the two systems occur at:

$$(C_l + C_p) N(MR-1) W_{sta} = (C_l + C_h) \frac{k_r k_u}{k_a} W_s + (C_l + C_p) N(MR-1) (2W_s + W_p) \quad (4)$$

$$(C_l + C_p) M = (C_l + C_h) \frac{k_r k_u}{k_a} R_s + (C_l + C_p) M(2R_s + R_p)$$

$$M = \frac{(C_l + C_h)}{(C_l + C_p)} \frac{k_r k_u}{k_a} \frac{R_s}{1 - (2R_s + R_p)} \quad (5)$$

So the effect of cost on mission factor is obtained from the weight in orbit relationship simply by multiplying by

$$\frac{C_l + C_h}{C_l + C_p}$$

The launch costs may vary from current values approaching \$1000/lb to as low as \$50/lb for recoverable boosters. Hardware costs may vary from \$100 to \$500/lb. Propellant costs are negligible.

Values of the cost factor, $\frac{C_l + C_h}{C_l + 0}$ are shown in Figure 3-2 for use with Figure 3-1.

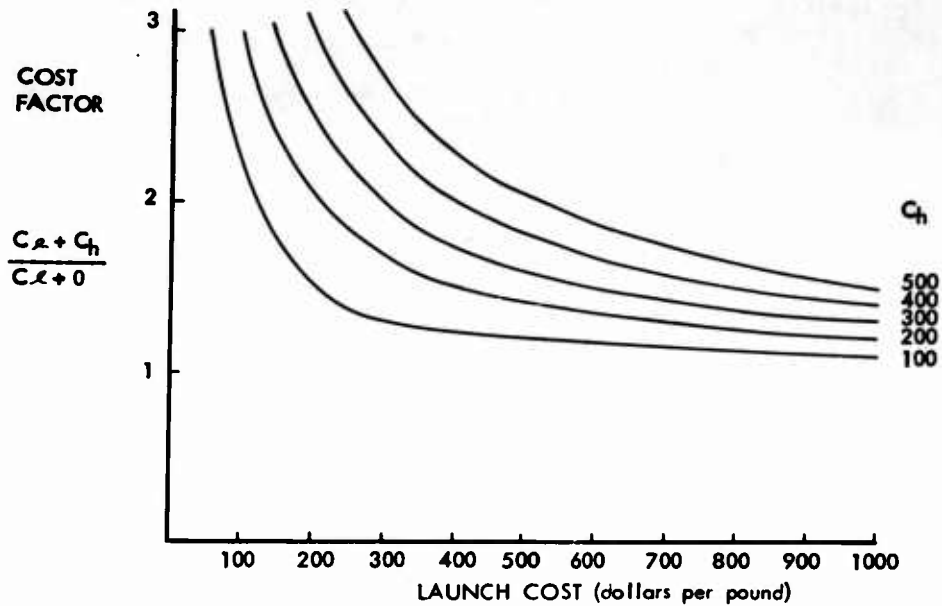

FIG. 3-2 LAUNCH COST

The effect of the cost factor on the break-even chart of Fig. 3-1 is to move the curves to the right, thereby reducing the region of profitable shuttle operation. As space technology expands, launch costs will decrease, and higher payloads will be of more interest. Consider, for instance, a situation with $R_s = 0.05$, $R_p = .2$ and a cost factor of 1 which has an equal cost M of 0.072. For this case, five missions of $MR = 1.015$ will pay for the shuttle. If the cost factor doubles and the payload ratio goes to 0.4, the equal cost M is $2 \times 0.1 = 0.2$. Ten missions of $MR 1.015$ are now required to justify the shuttle on a cost basis.

3.1.1.3 Space Station Resupply Economics

The cost relationships of Figs. 3-1 and 3-2 are now applied to the unmanned booster resupply operations described in para. 2.2. As indicated in para. 2.2, combining crew rotation and resupply operations involves scheduling problems such that consideration of unmanned methods is warranted; however, further comparison of manned and unmanned booster techniques is beyond the scope of this study. The following analysis compares the shuttle technique with each of the other unmanned techniques and establishes the conditions under which use of the shuttle is desirable on a cost basis.

3.1.1.4 Space Station Retrieval of Supplies

The data of Figs. 3-1 and 3-2 are directly applicable to the technique of maneuvering the space station to resupply module. The pertinent data derived for the material transfer mission defined in para. 2.3 is shown in Table 3-1. A shuttle of 1000 lb is used throughout.

Table 3-1
MATERIAL TRANSFER MISSION

Primary Weight W_{sta}	<u>Resupply</u>		R_s $\left(\frac{1000}{W_{sta}}\right)$	R_p $\left(\frac{W_p}{W_{sta}}\right)$	M	N at $\Delta V = 250$ fps	N at $\Delta V = 100$ fps
	Payload Weight W_p	Frequency per year					
30,000	2,000	13-30*	0.0333	0.0667	0.04	1.6	4
150,000	20,000	4**	0.00667	0.133	0.0078	1	1

*Fig. 2-1

**Based on 10,000-lb requirement per 45-day period. See para. 2.2.4.

The number of missions corresponding to the equal cost M and ΔV 's of 250 and 100 fps are shown for comparison with the number of missions per year required to maintain the two stations with the payloads considered. These two ΔV 's are selected from Figs. 3-7 and 3-8 to provide for 3σ launch errors using transfer times of 200 sec and 1600 sec. The number of missions at which costs are equal is well below the number required to supply the stations.

Packaging a resupply payload of 20,000 lb in a single module makes handling inconvenient on the ground and on arrival at the space station. A single shuttle would find a module of such magnitude awkward to maneuver. The effect on equal cost M is now calculated for the case of a 20,000 lb payload which is transported in ten trips. The cost equation now includes the number of shuttle trips, n , in the term which accounts for shuttle propellant

$$M = C_F \frac{k_r k_u}{k_a} \frac{R_s}{1 - (2n R_s + R_p)}$$

Using as above,

$$C_F = 1 \quad \frac{k_r k_u}{k_a} = 1$$

$$R_s = 0.00667 \quad R_p = 0.133$$

$$M = 1 \times 1 \times \frac{0.00667}{1 - (2 \times 10 \times 0.00667 + 0.133)} = 0.0091$$

As the large payload is associated with a large primary, the additional propellant used for ten shuttle trips does not significantly affect the trade-off.

3.1.1.5 Remotely Controlled Resupply Module

The module used with each unmanned launching is assumed to consist of communication, control, and propulsion systems equivalent in cost and weight to the corresponding systems of the shuttle.

The cost of the resupply operation using the unmanned, remotely controlled module, C_M , is the hardware cost plus the propellant cost to transfer the module and payload:

$$C_M = N k_r k_u (C_l + C_h) W_M + k_a N(MR-1) (W_M + W_p) (C_l + C_p) \quad (6)$$

This equation can be applied to reusable modules, but this mode of operation is not considered likely on the early systems, so we set

$$k_r = k_u = 1$$

$$C_M = N(C_1 + C_h) W_M + k_a N(MR-1) (W_M + W_p) (C_1 + C_p)$$

The number of missions at which use of the shuttle becomes profitable is now found by equating C_M to the shuttle cost of equation (4).

$$\begin{aligned} N(C_1 + C_h) W_M + k_a N(MR-1) (W_M + W_p) (C_1 + C_p) = \\ k_r k_u (C_1 + C_h) W_s + k_a N(MR-1) (2W_s + W_p) (C_1 + C_p) \end{aligned} \quad (7)$$

$$N = \frac{k_r k_u (C_1 + C_h) W_s}{(C_1 + C_h) W_M + k_a (MR-1) (C_1 + C_p) (W_M + W_p - 2W_s - W_p)}$$

with

$$R_M = \frac{W_s}{W_M}$$

$$\begin{aligned} N &= \frac{k_r k_u (C_1 + C_h) R_M}{(C_1 + C_h) + k_a (MR-1) (C_1 + C_p) (1 - 2R_M)} \\ &= \frac{k_r k_u R_M}{1 + k_a (MR-1) [(C_1 + C_p)/(C_1 + C_h)] (1 - 2R_M)} \end{aligned} \quad (8)$$

The payload term drops out as both techniques require the same propellant to transport the payload. This formulation neglects the effect of crew weight on shuttle propellant, however a check calculation shows the effect to be trivial for the small mass ratios considered.

The supply module weight, W_M , exclusive of resupply payload, compared with the shuttle weight is:

	$\frac{W_M}{}$	$\frac{W_S}{}$
Attitude control	72	72
Propulsion	128	128
Communication and control	44	44
Electrical power	44	87
Structure and mechanism	80	296
ECS	0	63
Miscellaneous and contingency	<u>30</u>	<u>67</u>
	398	757

Inserting numerical values for the terms that are determined by shuttle characteristics to display the system costs when this shuttle is used,

$$k_r = 1.25$$

$$k_u = 1.00$$

$$k_a = 1.25$$

$$R_m = \frac{W_S}{W_M} = 757/398 = 1.9$$

$$N = \frac{1.25 \times 1 \times 1.9}{1 + 1.25 (MR-1) (C_1 + C_p) / (C_1 + C_h) (1 - 2 \times 1.9)}$$

$$N = \frac{2.38}{1 - 3.51 (MR-1) (C_1 + C_p) / (C_1 + C_h)}$$

The cost factor is

$$CF = \frac{C_1 + C_h}{C_1 + C_p};$$

$$N = \frac{2.38}{1 - 3.51(MR-1)/CF}$$

This equation is plotted in Fig. 3-3.

Early resupply operations are expected to involve higher launch costs and larger errors than later systems. For the early case, the shuttle costs are lower when more than four launches occur. Fewer are required as launch costs decrease relative to hardware and maneuvering requirements decrease. Note that the mission constant, *M*, of the preceding discussion is not applicable to this case. Here increasing mass ratios work against the shuttle and the discarded module costs are not related to mass ratio.

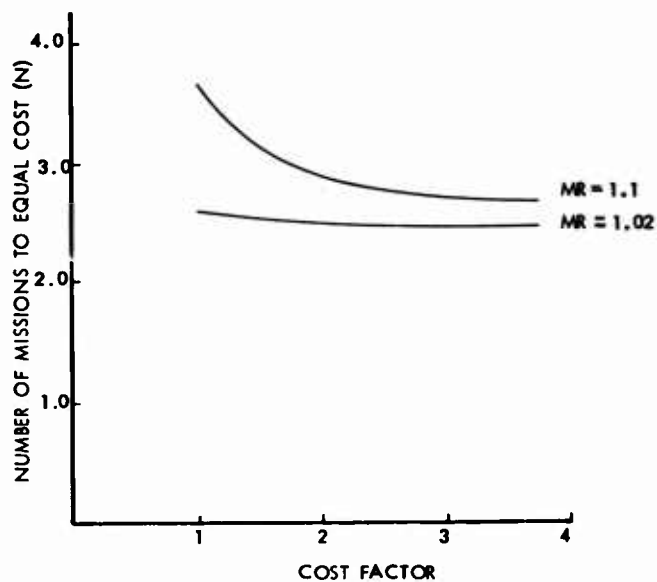

FIG. 3-3. REMOTE CONTROL MODULE EQUAL COST CHART

3.1.1.6 Emergency Escape Module to Retrieve Supplies

In this case, the reentry vehicle, generally proposed as an emergency escape means for space station crews, is used as a shuttle. Although this implies that a standby module is present to maintain the escape capability, the analysis neglects the hardware costs of the escape vehicle, i. e., $k_u = 0$. With W_E as the weight of the escape module, equation (4) for this case is

$$(C_1 + C_p) N (MR-1)(2W_E + W_p) k_a =$$

$$(C_1 + C_h) k_r k_u W_s + (C_1 + C_p) k_a N(MR-1)(2W_s + W_p) \quad (9)$$

$$C_F = \frac{C + C_h}{C_1 + C_p}$$

$$R_s = \frac{W_s}{W_E}$$

$$R_p = \frac{W_p}{W_E}$$

$$M(2 + R_p) = \frac{k_r k_u}{k_a} C_F R_s + M (2 R_s + R_p)$$

$$M = \frac{k_r k_u}{k_a} C_F \frac{R_s}{2(1 - R_s)}$$

This equation is plotted in Fig. 3-4.

The crew weight is regarded as payload, and must be included in calculations of propellant requirements. Total propellant in each vehicle is for twice the ΔV corresponding to the mass ratio as each makes a round trip.

Taking the shuttle weight as 1000 lb, and a typical escape vehicle weight as 7000 lb, $R_s = 0.143$; the equal cost M for a cost factor 2 is 0.170. Using

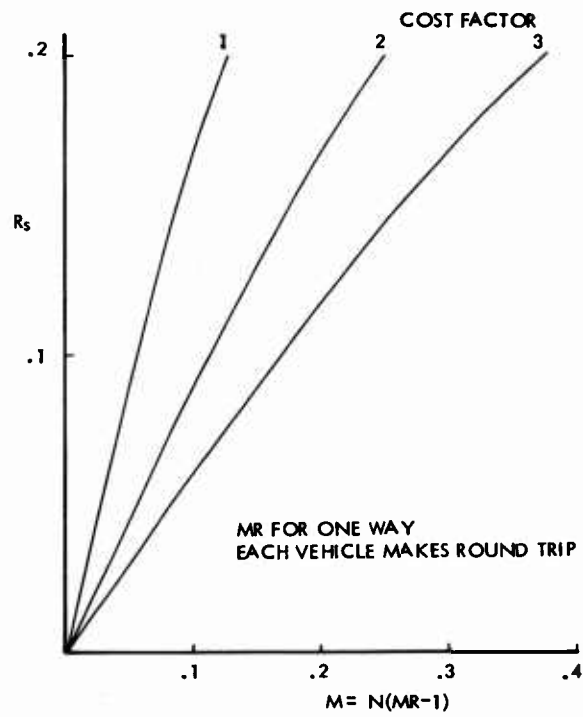

FIG. 3-4. ESCAPE MODULE - SHUTTLE EQUAL COST

the ΔV 's from Figs. 3-7 and 3-8 of 250/fps and 100 fps to accommodate 30 launch errors with transfer times of 600 and 1600 sec respectively, the equal cost number of missions are 7 and 17.

The chart, Fig. 3-4, can be used to determine the utility of supplying a new light vehicle instead of using existing (i. e. , no hardware charge) heavy vehicles for orbital operations.

3.1.1.7 Repair Mission Economics

The repair and maintenance of unmanned satellites may be performed by replacing the entire system whenever any part malfunctions, by designing "self-maintaining" features into the system, or by manned repair operations. The various aspects of these three techniques have been explored in References 3-1 and 3-2. As only the latter technique involves the shuttle, attention is called to the referenced reports for data regarding the other techniques.

The cost elements considered are: the initial cost of the satellite to be repaired, the cost of launching the target satellite and its replacements as required, and the opposing cost of the shuttle hardware, the shuttle propellant, and the spare parts and tools that are required for the repair of the target. The economic value of minimizing down-time is not evaluated, and the cost of operating the primary space station which serves as a base for the shuttle is not included in the analysis. Likewise it is assumed that the shuttle crewman is permanently on station and the cost of maintaining him between repair operations is not included. The trade-off considered is simply that of adding a shuttle to an existing space station for the specific purpose of maintaining an unmanned satellite compared to the cost of replacing the satellite whenever repair is required. It is further assumed that the payload carried by the shuttle to and from the target is part of the shuttle weight. Symbols have the same meaning as in previous analysis with the addition of:

C_T = Cost of the target satellite system

C_{hT} = Cost of hardware of the target satellite

$$R_T = \frac{W_S}{W_T} = \frac{\text{Weight of shuttle}}{\text{Weight of target}}$$

k_{rT} = Target refurbishing factor

$$C_{FT} = \frac{C_l + C_{hT}}{C_l + C_p}$$

$$C_{FS} = \frac{C_l + C_h}{C_l + C_p}$$

W_c = Crew weight

Cost of the target satellite being maintained

$$C_T = (C_l + C_{hT}) W_T N$$

The cost of the maintenance operation equals

$$\begin{aligned} & (C_l + C_h) W_s k_r k_u + k_a N (MR-1) 2(W_s + W_c)(C_l + C_p) \\ & + (k_{rT} - 1)(C_l + C_{hT}) W_T N \end{aligned}$$

The number of missions, N , (which corresponds to the number of failures experienced by the target), at which the cost of operating the system with the shuttle is equal to the cost of operating by total replacement, is found by equating these and solving for N :

$$N = \frac{(C_l + C_h) W_s k_r k_u}{(C_l + C_{hT}) W_T (2 - k_{rT}) - 2(MR-1)(W_s + W_c)(C_l + C_p) k_a} \quad (10)$$

Introducing the cost factor of the shuttle, C_{FS} , and that of the target, C_{FT} , and R_T , the break-even number of missions is

$$N = \frac{k_r k_u C_{FS}}{\frac{C_{FT}(2-k_r T)}{R_T} - 2k_a(MR-1) \left(1 + \frac{W_c}{W_s}\right)} \quad (11)$$

All the factors in this equation may be important in specific instances; however, for a given time period and state-of-the-art, typical values may be chosen for many of the parameters and the effect of varying the remaining factors demonstrated. The factors of most interest in this study are the relative weights of target and shuttle vehicles and the relative cost factors. The influence of these two parameters on the equal cost failure rate is illustrated by assuming the following values for the remaining factors:

$$k_r = k_{rT} = 1.25$$

$$k_u = 1 \text{ (i.e., shuttle is used only for this mission)}$$

$$k_a = 1.25$$

$$\frac{W_c}{W_s} = \frac{200}{1000} = 0.2$$

$$MR = 1.1 \text{ (i.e., the most difficult mission for the shuttle)}$$

$$C_{FS} = 1.5$$

$$C_{FT} = 1.5 \text{ and } C_{FT} = 2 \text{ to show the effect of relatively expensive targets}$$

$$N = \frac{1.25 \times 1 \times 1.5}{\frac{0.75 C_{FT}}{R_T} - 2 \times 1.25 \times 0.1(1+0.2)} = \frac{2.5}{\frac{C_{FT}}{R_T} - 0.40}$$

This relationship is plotted in Fig. 3-5.

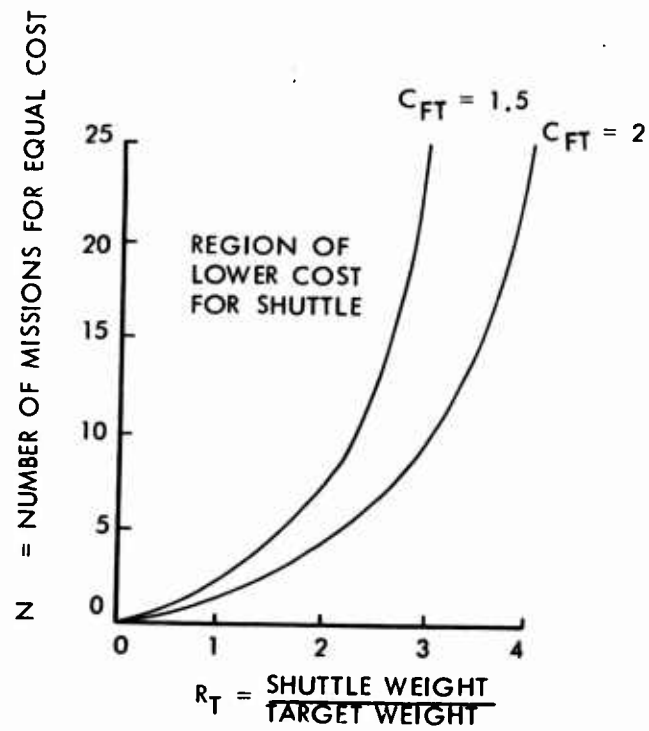

FIG. 3-5. REPAIR BY SHUTTLE VS REPLACEMENT

As an example, consider a target satellite weighing one-half of the shuttle weight (e.g., a 500-lb target with a shuttle-weight of 1000 lbs), $R_T = 2$, and equal costs occur at 7 missions. On an annual rate, this corresponds to a mean time to failure of 52 days for the target. The more expensive target with a cost factor of two, has equal costs at four missions. If the expense is due to incorporating redundancy or self-maintaining features in the target, these improvements should increase the MTF to 91 days to match the cost of the shuttle type of operation.

3.1.1.8 Assembly Mission Economics

The decision to launch space vehicles as units, or to assemble them in orbit, depends on many factors peculiar to each situation. Most of these factors, such as booster availability for particular missions, cannot be evaluated in this study. Therefore, only the role of the shuttle in assembly operations is evaluated below.

The assembly mission consists of locating the modules to be assembled, transporting them to the assembly area (area is interpreted as "in orbits with nearly equal elements"), making the structural and functional connections, and checking out the complete vehicle. The step of transporting the components to the assembly site may be done in several ways analogous to the resupply operation methods, specifically:

- Each component is manned and proceeds under its own power and guidance to the site
- Each component is unmanned but contains a control system and propulsion system and proceeds to the assembly site by remote control
- The earth-to-orbit ferry vehicle is used as a shuttle to transport the components
- The entire assembly is flown from component to component in the assembly sequence, each component being added at its position in orbit
- The shuttle is used to transport the separate components

The cost analysis for these various techniques follows the same reasoning followed in the resupply operation section.

The technique of maneuvering each component to the assembly site by crew members boosted with and normally housed in that component, obviates the need for a shuttle for transport.

By reference to Fig. 3-3 it is observed that the unmanned remote control operation, regarding N as the number of modules to be assembled, has equal costs at approximately three modules for the transport phase alone.

The use of the earth-orbit ferry as a shuttle may be evaluated using Fig. 3-4 as this trade-off is independent of payload, i.e., assembly component weight.

The technique of maneuvering the entire assembly to each component in turn is applicable if the launching of each component is scheduled to prevent large separations from occurring during the assembly operation. The trade-off for each step of this operation may be assessed using Figs. 3-1 and 3-2 with $N = 1$, the assembled weight is W_{sta} , and the weight of the new component W_p . Using the example of para. 2.3, $W_{sta} = 150,000$, $W_p = 117,000$, shuttle weight = $4 \times 1000 = 4000$ as four shuttles are required to handle the large payload.

$$R_s = \frac{4000}{150,000} = 0.0267$$

$$R_p = \frac{117,000}{150,000} = 0.78$$

$M = 0.156$ for unity cost factor, consequently, only large maneuvers justify one-time use of the shuttle to handle payloads whose weight approaches the primary weight if only the cost of weight in orbit is considered.

The operation of joining and checking out the modules once they are within proximity of each other may be performed automatically; by crewmen in space suits, by crewmen within each module, or by assembly crews in shuttles. The primary considerations in this case are functional rather than economic, depend heavily on the detail design of the components to be joined, and may be decisive.

3.1.1.9 Training Mission Economics

The training mission described in Section 2.3 includes a number of experiments and training operations that depend on the ability to maneuver the spacecraft. The question to be examined is whether or not it is worthwhile to orbit a shuttle with Gemini?

As the complete program includes many factors besides those involving the shuttle, the question may be answered from two points of view: (1) Certain experiments are to be performed and the data obtained in the most economical manner, and (2) A certain number of launchings are programmed and the problem is to extract the maximum information from the experiments carried. The charts based on cost-per-lb in orbit are applied to the first approach and a comparison of maneuvering ΔV available is used to evaluate the shuttle by the second approach. As the detail data necessary to evaluate second order effects (e.g., modifications to the adapter to accept the shuttle) is not available, the analysis is based on the approximate data of para. 2.2.1 and a shuttle hardware weight of 635 lb. The crewman's weight is taken as 200 lb.

The characteristic velocity desired for maneuvering at which the higher mass ratio available with the shuttle is advantageous is found from Fig. 3-4 using the constants:

Launch cost	$C_1 = \$1000/\text{lb}$
Shuttle cost	$C_h = \$ 500/\text{lb}$
Propellant cost	$C_p = \$ 1/\text{lb}$

$$\frac{C_1 + C_h}{C_a + C_p} = \frac{1000 + 500}{1000 + 1} = 1.5$$

$$R_s = \frac{635}{7000} = 0.0908$$

Reading from the chart for $C_F = 1.5$, $N = 1$, we find $M = 0.076$. The corresponding mass ratio for the two-way mission is 1.152. This mass ratio is obtained with 1090 lb of propellant in a 7000-lb vehicle + 200-lb crew. The weight of a shuttle plus propellant to do the same maneuver is $635 + 127 = 762$ lb. The interpretation is that the weight difference of $1090 - 762 = 328$ lb, when valued at \$ 1000/lb for use in other experiments, pays for a shuttle vehicle valued at \$ 500/lb.

When the experimental ΔV is specified, the desirability of introducing the shuttle is evaluated comparing the ΔV 's available with each vehicle.

The maximum characteristic velocity available for experimentation without the shuttle if 700 lb is available for this task is:

$$V_G = 300 g \ln \left(\frac{7000 + 200 + 700}{7000 + 200} \right) = 885 \text{ fps}$$

The maneuvering ΔV available with the shuttle of 635 lb empty and 700 lb with propellant is:

$$\Delta V_S = 300 \text{ g} \ln \left(\frac{635 + 200 + 65}{635 + 200} \right) = 750 \text{ fps}$$

The upper limit on shuttle weight makes this ΔV very sensitive to shuttle empty weight. For instance, if 35 lb of inert weight is removed from the shuttle, the ΔV available is:

$$\Delta V_S = 300 \text{ g} \ln \left(\frac{600 + 200 + 100}{600 + 200} \right) = 1125 \text{ fps}$$

3.1.2 Propulsion System - Mission Considerations

The interactions of the propulsion system characteristics with the mission requirements are discussed in this section. Those factors which are concerned with attaining the desired ends most efficiently, e.g., choice of propellant, operating pressures, safety considerations, are discussed in Section 6.4. The choice of and limits upon the objectives are discussed in the following.

The propulsion system has two major characteristics, thrust and total impulse which, once chosen by the designer, control the capabilities available to the operator. The operator, in turn, has three major variables, range, payload, and transfer time, which he may adjust to suit the situation at hand. These primary variables are coupled through a number of secondary items:

- Guidance technique employed
- Sensory devices employed
- Guidance and maneuvering errors
- Engine life
- Maneuvering capability
- Orbit situation
- Reserves for various failure modes, system and technique errors, operational flexibility, accidents
- Probability of mission success desired

Each of these items is treated briefly before proceeding to the more important trade-offs.

The guidance and navigation system suggested for the shuttle is described in Section 4.6. As shown in para. 4.6.7, this modified visual homing technique is expected to yield such accuracy that error magnitude may be ignored in the trade-off studies which follow. The design range of the radar does, however, influence the vehicle size, weight, and power requirements. Comparing the trajectory of the error analysis (Fig. 4-37 of Section 4.6), with those of Section 4.3, the path resulting from this technique is found to be similar to the shorter transfer time ideal trajectories, i.e., nearly straight in target-centered coordinates. The more efficient transfers which save propellant at the expense of time, deviate considerably from the line-of-sight track. Therefore, in high-payload, or long-range situations, the operator has the option of using the communication guidance scheme when the primary can supply the requisite data.

Attaining a reasonable engine life and the attendant reliability and replacement logistics advantages is largely a function of proper design. This consideration does impose a lower limit on thrust, however, in that the thrust must be large enough to perform the most difficult missions within the usable life of the engine.

To accomplish their missions, it is necessary that the shuttle be able to operate in close proximity to other vehicles. Such operation is feasible only by exploiting the crew's capabilities to the fullest, therefore, handling qualities comparable to other vehicles in all degrees of freedom are desired. The distances required to stop from various initial speeds are plotted in Fig. 3-6. An allowance of a 0.2-second delay in pilot-plus-system response with the stated accelerations is included in Fig. 3-6. Accepting the criterion that a pilot must be within 50 feet of the target to make reliable estimates of range and range rate, there are three alternatives:

- (1) Installing large (10,000 lb thrust) engines
- (2) Limiting closing speeds to less than 50 fps
- (3) Supplementing the pilots vision with other sensors

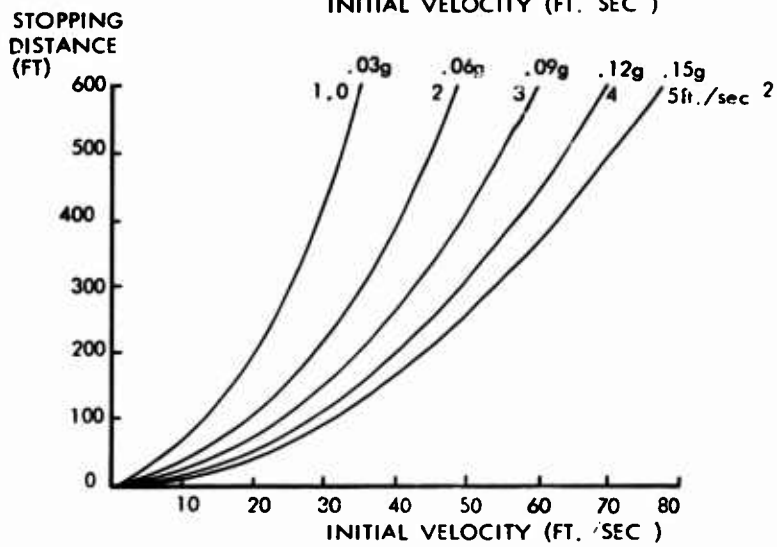
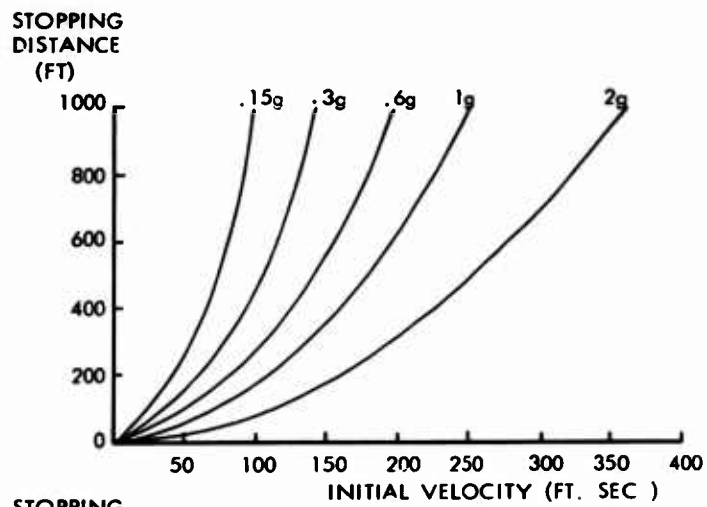

**FIG. 3-6 BRAKING DISTANCE
(0.2 SEC DELAY TIME)**

The first imposes a severe weight penalty, the second restricts the range to less than 3 n.mi. (Fig. 4-16). The third is adopted as visual aids are desired as discussed in Section 4-6.

3.1.2.1 Orbital Situation

The relative position of the primary and the target vehicles is important to the shuttle operation. The distance separating the two vehicles, and the relative direction of the target from the primary affect the ΔV and transfer time. The distance between the vehicles is governed by the accuracy with which the orbits can be determined and by the precision with which the primary can maneuver. Three general cases are recognized for this analysis.

Missions which require launching unmanned carriers from Earth to orbit, are subject to the booster and launching errors. An estimate of these is made in Section 4.1 and the three sigma values are plotted in Figs. 3-7 and 3-8. The figures show that if a transfer time of 600 seconds is desired, a ΔV of 250 fps is adequate for these launch errors. By extending the time to 1600 seconds, an ideal ΔV of less than 100 ft/sec is adequate.

As the launch vehicle may have velocity as well as position errors, the initial errors discussed above increase with time. An estimate of this error and the situation during the hour following orbit injection is also presented in Section 4.1 and shown in Fig. 4-3. The three sigma value of launch error at the end of an hour has grown to 20 n.mi. Many shuttle missions are concerned with primary and target vehicles that have been in space for some time and for which the orbital elements are accurately known. In this case, the primary is assumed to transfer to the neighborhood of the target by a Hohmann transfer. The propagation of initial position errors through a Hohmann transfer is studied in Section 4.2, and the results indicate that the final position error is eight times the initial position error. For these well known orbits, initial position errors of the order of hundreds of feet are possible when the vehicle has passed over a tracking station within the previous two or three revolutions. A 3σ value of initial position error of one n.mi. appears conservative which leads to three sigma values of shuttle design range of eight n.mi., which is not critical. The 20 n.mi. value is chosen for design.

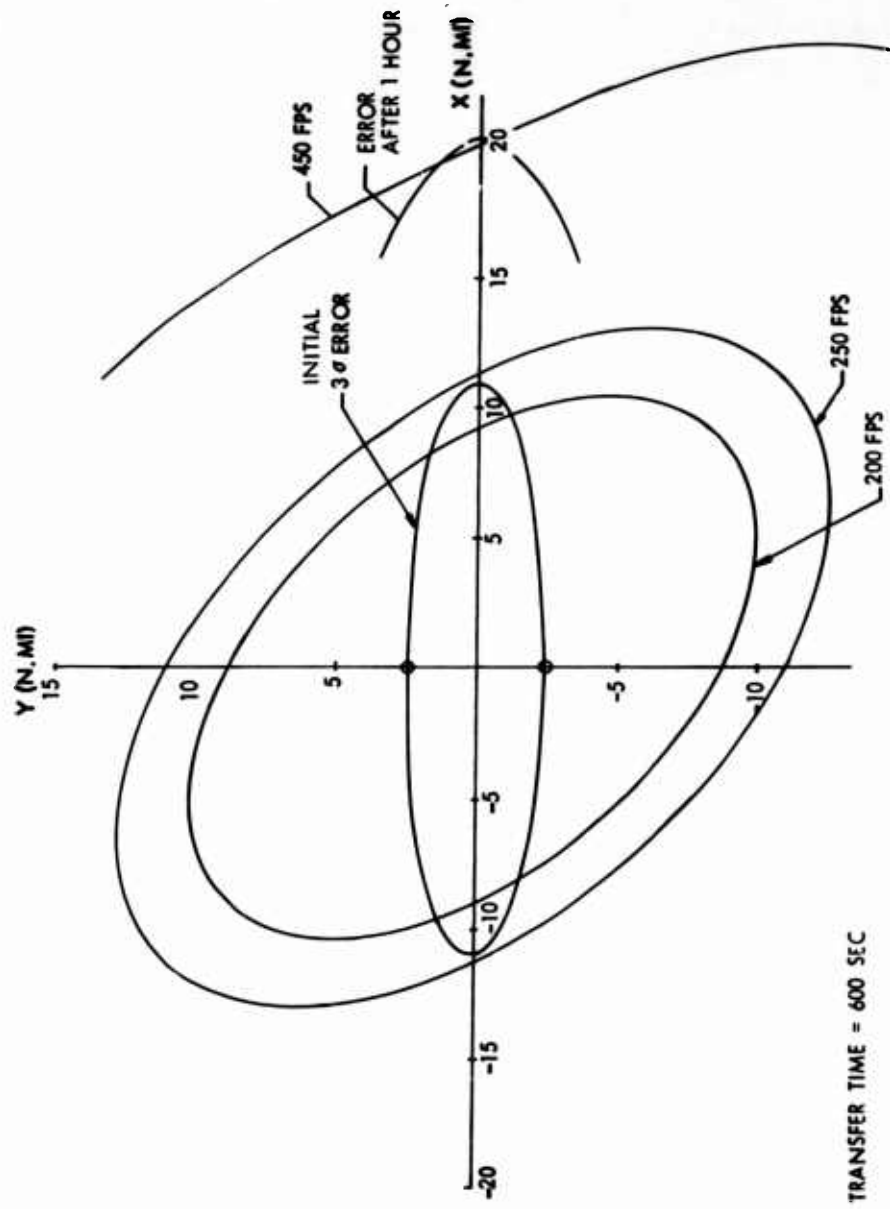

FIG. 3-7 REQUIRED RANGE VS AVAILABLE RANGE

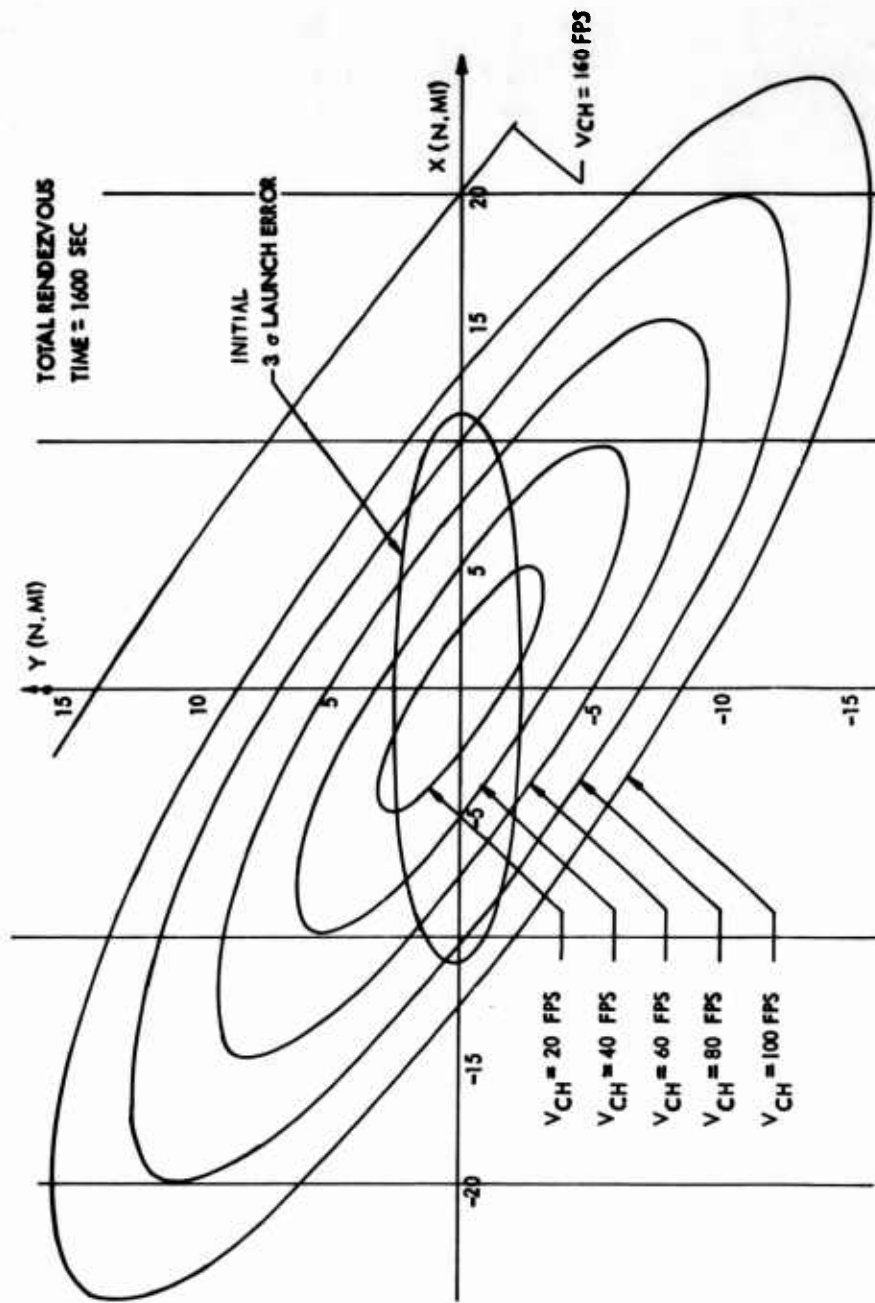

FIG. 3-8 REQUIRED RANGE VS AVAILABLE RANGE

The trajectory analysis of Section 4.3; e.g., Fig. 4-13, shows large variations in ΔV required for different orientations of primary and target vehicle. The most difficult transfer is when the target is below and ahead of the primary. Unfortunately, as shown in Figs. 4-14 and 4-15, position errors after a Hohmann transfer are frequently in this orientation. The mission analysis conservatively combines the ΔV requirement for the worst orientation with the design range of 20 n. mi.

3.1.2.2 Influence of Thrust on Propellant Requirements

The characteristic velocities of Section 4.3 are based on two impulse transfers. However, the maximum payloads considered for the shuttle reduce the available acceleration to a point where a correction to the ideal velocities is necessary. The correction is calculated on the basis of an equivalent maneuver which requires the same transfer time, T , and which has an average velocity, \bar{V} defined by $\bar{V} = \frac{\Delta V_i}{2} = \frac{\text{Ideal characteristic velocity}}{2}$.

The constant acceleration, a , is assumed to act for a time, t , at the beginning and again at the end of the maneuver. The assumption of equal starting and stopping impulses is a reasonable approximation to most of the transfers considered and is applied to all cases; a more precise estimate of this error for each possible situation is not warranted at this time. The corrected characteristic velocity ΔV_a is:

$$\Delta V_a = 2 at$$

$$\text{Equivalent Distance} = \bar{V}T = 1/2at^2 + at(T - 2t) + 1/2at^2$$

$$\bar{V} = 1/T[at^2 - 2at^2 + atT]$$

$$\Delta V_a / \Delta V_i = \frac{1}{(1 - \frac{t}{T})}$$

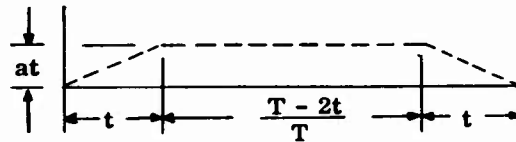

This correction ratio reaches a maximum of 2, when t/T is 0.5, its maximum value to include the braking maneuver, as shown in Fig. 3-9.

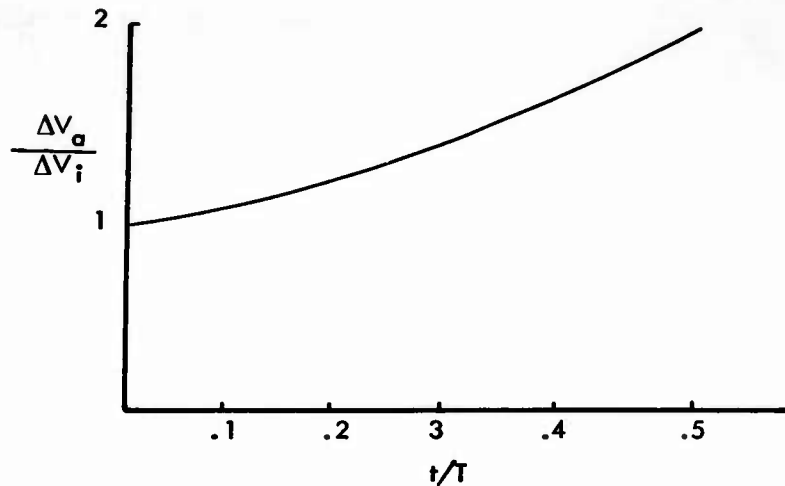

FIG. 3-9 NON-IMPULSIVE THRUSTING ΔV CORRECTION

The correction factor for non-impulse operation is applied to ideal characteristic velocities to produce the propulsion mission interaction chart of Fig. 3-10. This example is based on the least advantageous orientation of the primary to target, 135 deg, on a shuttle weight of 1,000 lb, and a thrust of 200 lb. The payloads and accelerations associated with each are:

Payload, lb	0	2000	6000	20,000	117,000*
Total Weight, lb	1000	3000	7000	21,000	121,000
Acceleration g	0.2	0.0667	0.0286	0.00953	0.00663
Acceleration, ft/sec ²	6.44	2.14	0.920	0.306	0.213

* Four shuttles are used with this payload

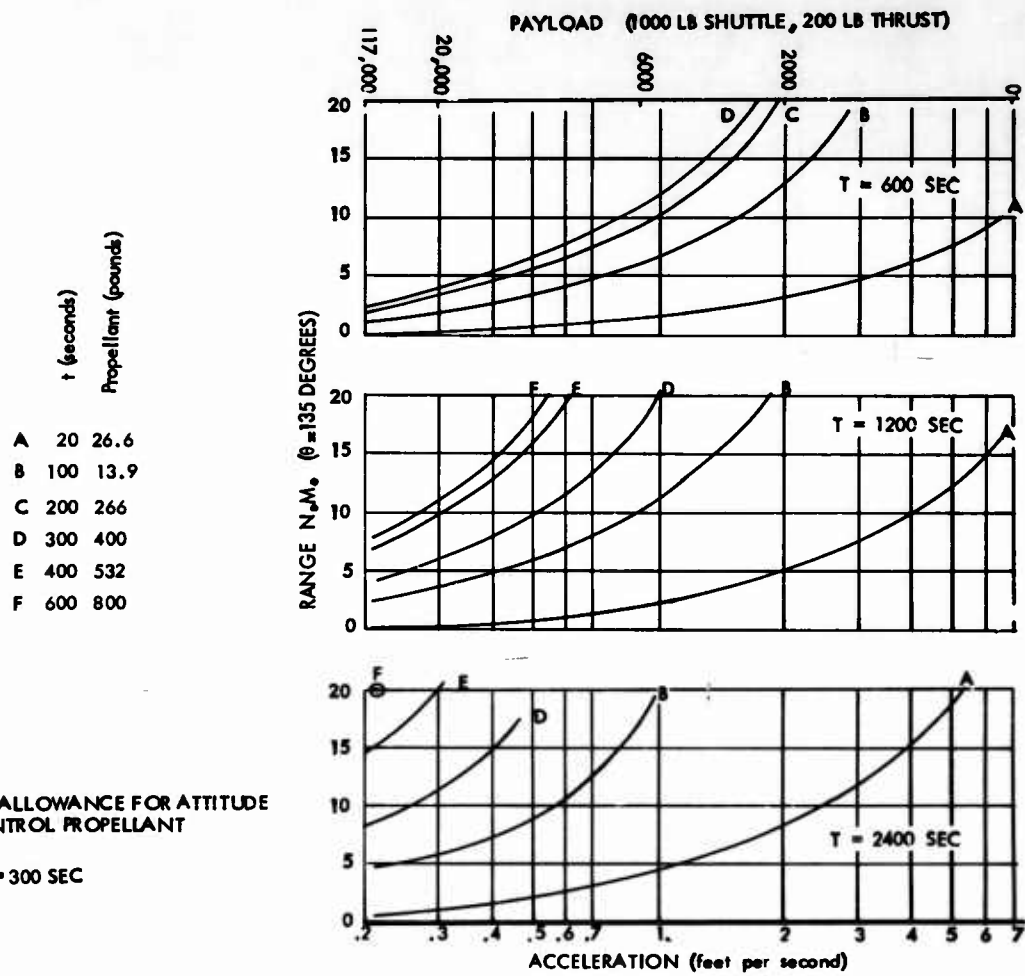

FIG. 3-10 PROPULSION - MISSION INTERACTION

The chart is used for flight planning by selecting the transfer time required to carry the payload over the range desired with the propellant available. For instance, a shuttle with 200 lb of propellant is represented by curve C and can carry a 2000 lb payload over 20 n.mi. in 600 seconds. If the desired payload is 6000 lb, a transfer time of slightly over 1200 seconds is necessary. Payloads of 20,000 lb and over require transfer time of about half a period, (i.e., approach Hohmann transfers); burn times (2t for each traverse), approach the maximum attainable with radiation-cooled nozzles.

The chart, as drawn with payload as abscissa, presents the performance of a constant thrust vehicle. Weight and thrust, however, enter the equations only through the acceleration. An acceleration scale is therefore provided along the abscissa, and the same chart may be used for studying the design trade-offs of any shuttle for which

$$a = \frac{Fg}{W} = \frac{\text{THRUST}}{\text{TOTAL MASS}}$$

$$\text{and propellant required} = \frac{2 F \cdot t}{I_{sp}}$$

If a typical shuttle vehicle is chosen, and we fix the travel time and range, we may then optimize the main propulsion thrust level.

- W_{MP} = Main propulsion system weight
- W_C = Thrust chamber assembly weight
- W_P = Plumbing and valve weight
- W_{PR} = Pressurant system weight
- W_{PROP} = Propellant weight
- W_S = Supports and mounting hardware weight
- W_T = Propellant tank weight
- F = Total one direction thrust
- W_{AVER} = Average vehicle weight

$$\begin{aligned}
 W_{MP} &= [W_C] + [W_P] + [W_{PR} + W_{PROP}] + [W_S] + [W_T] \quad (12) \\
 &= [0.8 + 0.092F] + [9 + 0.05F] + \left[12 + 0.13 W_{PROP} \right. \\
 &\quad \left. 0.20 (W_C + W_P + W_{PR}) \right] + 0.10 W_{PROP}
 \end{aligned}$$

$$W_{MP} = 26 + 1.26 W_{PROP} + 0.17 F \quad (13)$$

$$\Delta V_a = \frac{\Delta V_i}{1-t/T} \quad (14)$$

$$\Delta V_a = 2 \left(\frac{F}{m} \right) t = \frac{2F g t}{W_{AVER}} \quad (15)$$

Equating (14) and (15) and solving for t:

$$t = \frac{T + \sqrt{T^2 - \frac{2\Delta V_i W_{AVER} T}{F g}}}{2} \quad (16)$$

$$W_{PROP} = \frac{2 F \cdot t}{I_{sp}} \quad (17)$$

Substituting (16) into (17) :

$$W_{PROP} = \frac{F}{I_{sp}} \left[T + \sqrt{T^2 - \frac{2\Delta V_i W_{AVER} T}{F g}} \right] \quad (18)$$

Substituting (18) into (13) :

$$W_{MP} = 26 + 1.26 \frac{F}{I_{sp}} \left[T + \sqrt{T^2 - \frac{2\Delta V_i W_{AVER} T}{F g}} \right] + 0.17 F \quad (19)$$

Figure 3-11 shows the main propulsion system weight vs thrust level for a shuttle vehicle having an average weight of 1000 lb. A one-way trip of 20 n. mi. is assumed, and travel times of 600, 1200 and 2400 seconds are plotted. Figure 3-12 is similar, except it used an average weight of 30,000 lb, corresponding to four shuttles moving a 116,000 lb payload. The range in this case is assumed to be 5 n. mi.

Figure 1-3 presents systems weight vs mission time. The propulsion and attitude control systems used a mission time of 3.75 hours plus round trip travel time. The 3.75 hours at target allows for repairs. The minimum weight propulsion and attitude control systems occur during a Hohmann transfer, or a mission time of about five hours.

3.1.3 Maintenance Mission Performance Vs Equipment Weight

In designing the shuttle for its various missions, questions arise concerning the equipment that must be added to the basic vehicle to perform a given mission.

For the maintenance mission, it can be said that the more equipment available to the worker, the higher the probability of mission success. If, for example, the worker was given only a tool kit to perform the mission, the probability of his isolating and repairing a malfunction is low. By adding a set of spares the probability becomes higher and then by giving him a test set, the probability becomes still higher.

Since the shuttle must accommodate space and weight provisions for the maintenance equipment, its size and configuration can be based on the level of maintenance desired. In other words, a minimum shuttle that could accommodate only a tool kit would be of little value as a maintenance vehicle. However, the initial cost of the vehicle and its subsequent operational costs would be small. In comparison, a vehicle that is optimized for maintenance might become as big as an astrotug with a consequent increase in cost.

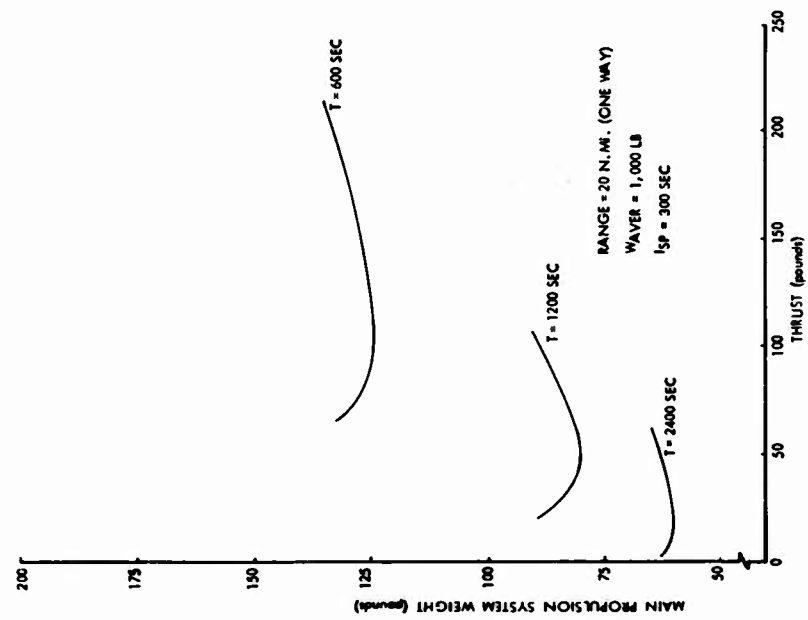

FIG. 3-11 OPTIMUM THRUST FOR ORBITAL SHUTTLE

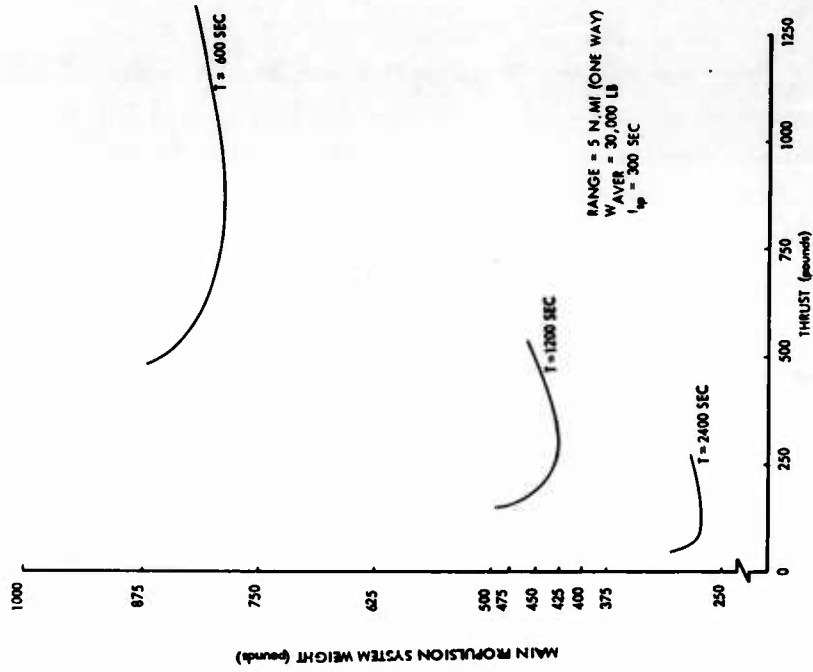

FIG. 3-12 OPTIMUM THRUST FOR ORBITAL SHUTTLE WITH PAYLOAD

To gain insight on the trade-offs between vehicle size owing to maintenance equipment weight and the probability of mission success, studies are made which result in the information given in Fig. 3-14.

3.1.3.1 Satellites to be Maintained

For purposes of this study, satellite systems are assumed that fall within the category of reconnaissance missions. Such satellites appear to be representative of those that might be operational in the 1965-67 time period. The complex consists of four satellites, each carrying its primary system and subordinate systems which are common to all satellites. As shown in Fig. 3-13, the primary systems are: (1) a radar mapping system, (2) an infrared mapping system, (3) a photo mapping system, and (4) a ferret system. The systems common to all satellites are: (1) stabilization and control, (2) electrical power, and (3) a communication system for reporting the data to ground stations. All satellites are assumed to be unmanned.

3.1.3.2 Maintenance Equipment

The maintenance equipment required to perform the mission and their associated weights are tabulated in Table 3-2. The equipment associated with each kit represents only a given technique for maintenance and may change with each designer's thinking. However, the weights do not vary significantly, and they are the important facets of this study.

3.1.3.3 Probability of Mission Success

To equate the weight of maintenance equipment with the probability of mission success, values are assigned according to Table 3-3. It is assumed that the maximum probability of mission success is of the order of 90 percent. In other words, there is a 10 percent chance of mission failure owing to inability to isolate trouble with the given test equipment or lack of appropriate spares. Given only a tool kit, the worker can probably realize a 15 percent successful accomplishment of the mission. As he is given additional equipment, in the order shown, the probability of mission success progressively increases until the 90 percent value is realized.

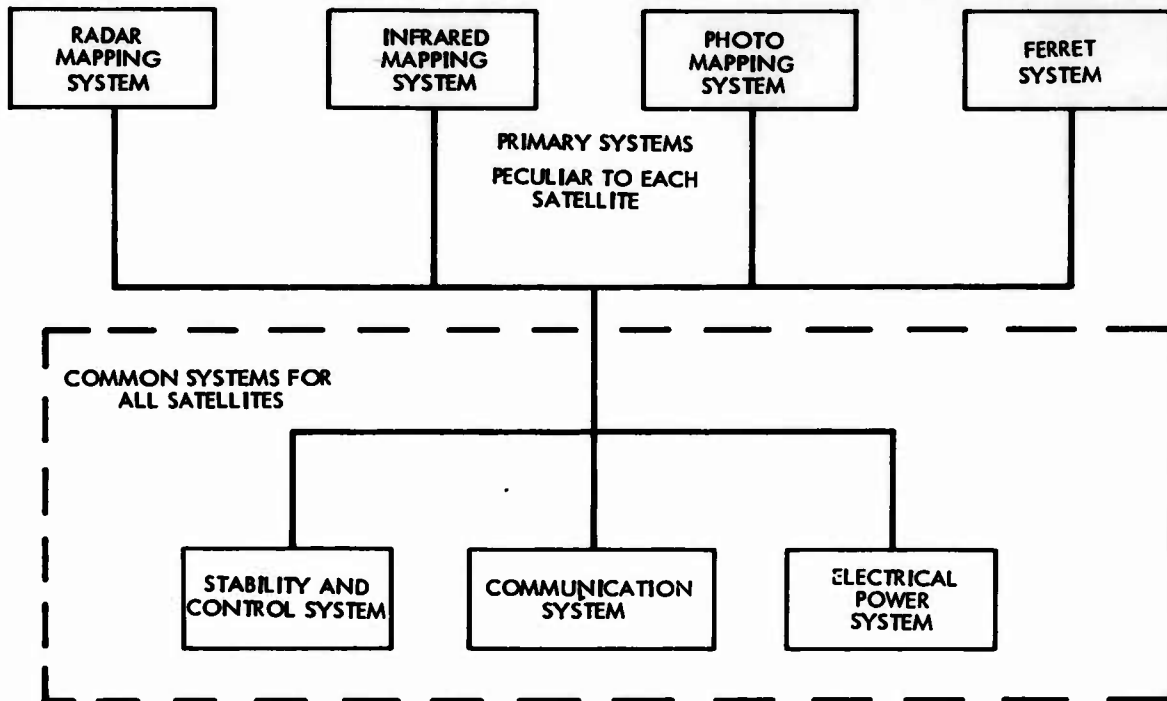
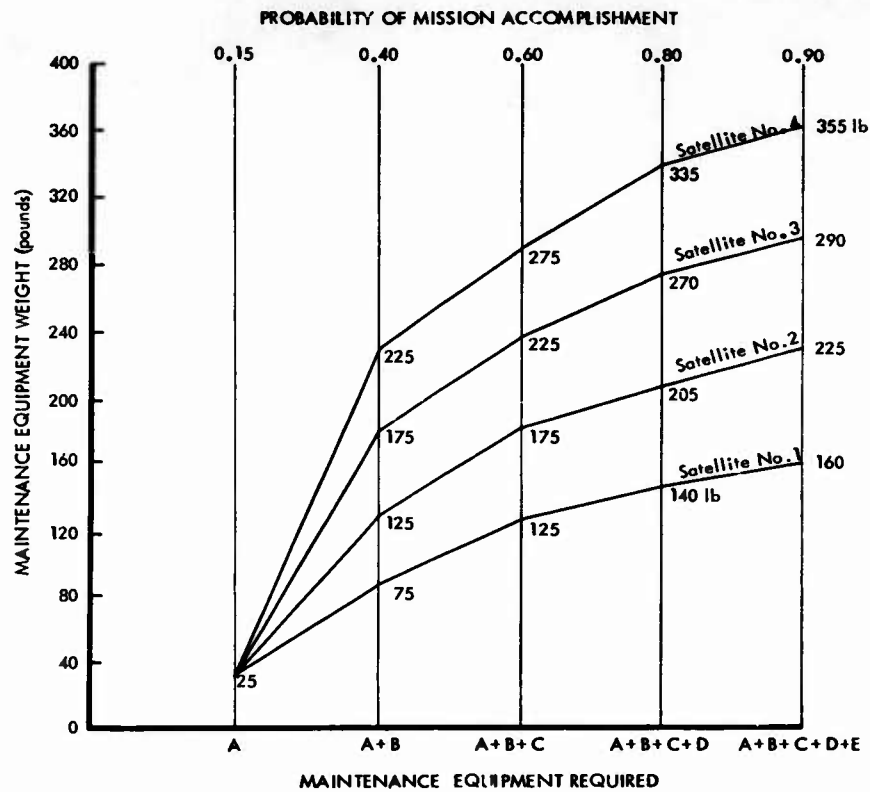

FIG. 3-13 RECONNAISSANCE MISSION SATELLITE SYSTEMS



Code	Maintenance Equipment
A	Hand tools
B	Primary system spares
C	Common system spares
D	Primary system test set
E	Common systems test set

FIG. 3-14 SHUTTLE WEIGHT INCREASE WITH INCREASE IN PROBABILITY OF MISSION SUCCESS

Table 3-2

MAINTENANCE EQUIPMENT AND ASSOCIATED WEIGHTS

HAND TOOLS KIT - 25 lb, 350 cu in.

Assorted wrenches
Cutting tools
Camlock tool
Multimeter
Neon bulb with leads
Special purpose tools

Primary System Spares - 50 lb,
800 cu in

Common System Spares - 50 lb,
800 cu in

Spare parts kits are assumed to be components for organizational and field level maintenance. One kit required for each primary system and one kit for all common systems.

PRIMARY SYSTEM TEST SETS

Radar Test Set - 15 lb,
355 cu in, 15 watts

Infrared Test Set - 15 lb,
490 cu in, 18 watts

RF signal generator
Pulse encoder
Directional coupler
Isolator
Power meter
Dummy load

Calibrated heat source
Test pattern
Oscilloscope
Audio generator
Command signal generator

Photo Test Set - 15 lb,
350 cu in, 10 watts

Ferret Test Set - 15 lb,
540 cu in, 30 watts

Calibrated light source
Test pattern
Film processing kit
Command signal generator
Optimal viewer

Multi-band signal generator
Digital encoder
Data recorder
Correlation detector

Table 3-2

MAINTENANCE EQUIPMENT AND ASSOCIATED WEIGHTS (Continued)

COMMON SYSTEMS TEST SET - 20 lb, 580 cu in, 17 watts

RF signal generator	Pulse encoder
Power meter	Audio signal generator
Isolator	Function switching and metering
Dummy load	Command signal generator

Table 3-3

MAINTENANCE EQUIPMENT REQUIRED FOR A GIVEN
MISSION SUCCESS PROBABILITY

<u>Code</u>	<u>Equipment</u>	<u>Weight (lb)</u>	<u>Mission Success Probability*</u>
A	Hand tools	25	0.15
B	Primary system spares	50	0.40
C	Common systems spares	50	0.60
D	Primary system test set	15	0.80
E	Common systems test set	20	0.90

* Added successively, e.g., A + B + C = 0.60

3.1.3.4 Shuttle Weight vs Mission Success Probability

Figure 3-14 shows the increase in shuttle weight for a given probability of mission success. From the bottom curve it can be seen that as equipment is added to the shuttle for a given mission, the probability of success progressively increases with weight. To service one satellite with a 0.90 probability of success, 160 lb of equipment is required. If more than one satellite is to be serviced on the same mission, the other curves apply. For example, if all four primary systems are to be serviced on one mission with a 90 percent probability that all systems will be restored to operation, the shuttle weight will increase 355 lb.

3.1.4 System Trade-off Summary

Section 3.1 discusses the cost factors involved in space systems that operate with and without the shuttle; the interaction of mission range, transfer time, and shuttle design characteristics; and the effects on the probability of mission success of varying the equipment provided in the shuttle. The analysis is based on the missions defined in para. 2.3, and the specific results obtained are summarized in Table 3-4. Much of the data presented, however, is applicable to more general situations which are briefly described below.

3.1.4.1 Cost

It is convenient to evaluate the applicability of the shuttle to various space systems in terms of the equal cost values of three parameters, W_s , M , and C_F . W_s is the ratio of shuttle weight to alternate vehicle weight; M is the mission factor, the product of number of missions to be performed and the (mass ratio - 1); and C_F is the cost factor, the ratio of (launch + hardware cost) to (launch + propellant cost).

The relationship of these parameters for the situation in which a shuttle is used to traverse from a primary to a target and return with a payload, and the competing system wherein the primary traverses to the target is shown in Fig. 3-1. The relationships at equal cost for a shuttle competing with a system in

which each payload is provided with a propulsion and control system and is remotely operated is shown in Fig. 3-3. The comparison of two shuttles of unequal weight performing the payload retrieval mission is shown in Fig. 3-4. The trade-off of shuttle operation for repair of unmanned satellites with replacement of the satellite is shown in Fig. 3-5.

3.1.4.2 Propulsion System - Mission Consideration

The interaction of the thrust and total impulse values chosen by the designer with the range, payload, and transfer times available to the operator is discussed in para. 3.1.2.

The comparison of launch errors with ideal characteristic velocities shows that a ΔV of 450 fps is adequate for the ranges expected if transfers are made in 600 seconds, while 180 fps is adequate if transfer times of 1600 seconds are admissible. Fig. 3-10 is then developed which accounts for the increased propellant required as burning times are increased. This chart may be used for mission planning for the particular shuttle used, and as a design chart by reducing the specific values of mass and thrust used to accelerations. The general data is then applied to optimizing the propulsion system weight for a specific shuttle in terms of thrust, transfer time and payload. As shown in Figs. 3-11 and 3-12, propulsion system weight varies strongly with transfer time, but relatively slightly with thrust level. That is, propellant is the major variable, the effect of thrust on empty weight is small. Consideration of the electrical power system and environmental control system off-set somewhat the advantages of long transfer times; as shown on Fig. 1-3, the total weight curve is fairly flat for one-way transfer times over 600 seconds, dropping from 385 to 340 lb at the optimum of 2250 seconds.

3.1.4.3 Maintenance Mission Performance

The study of the effect of the amount of tools, spares, and checkout equipment provided on the probability of mission success indicates (Fig. 3-16) that the usefulness of a repair mission is jeopardized if the worker is not provided

with reasonable equipment. A weight of equipment of 160 lb is expected to be necessary to yield 90 percent success in servicing one type of reconnaissance satellite; if four types of sensors are involved, the weight grows to 355 lb.

Table 3-4

MISSION ANALYSES AND RESULTS

Mission	Primary Weight (pounds)	Payload or Target Weight (pounds)	Shuttle Weight (pounds)	Cost Factor C_F	Equal Cost Mission		
					M	N	MR***
<u>Training</u>	7,000	-	635	1.5	0.070	1	1.076
<u>Material Transfer, Resupply</u>							
Shuttle vs	30,000	2,000	1000	1	0.08	3.2	1.025
Primary Retrieval	150,000	20,000	1000	1	0.012	8	1.01
						1.2	1.01
Shuttle vs Remote	398	-	757	2		2.89	1.1
Control Module	-	-		2		2.48	1.02
Shuttle vs	7,000	-	1000	2	0.175	7	1.025
Gemini type	7,000	-	1000	2	0.175	17	1.01
<u>Maintenance</u>	-	500	1000	*1.5/1.5 1.5/2.0		5 3.4	1.1 1.1
<u>Assembly</u>	150,000	117,000	**4000	1	0.156	1	1.156

Blanks are values not pertinent to particular situations.

* Cost factor shuttle/cost factor target

** Four shuttles of 1000 lb each

*** Mass ratio for one-way trip; shuttle always makes round trip.

3.2 OPERATIONAL CONSIDERATIONS

3.2.1 System Design and Operation

The operation of the shuttle requires special provisions in the station's physical design. Although station design and operation is beyond the scope of this study, the major implications are discussed in this section.

3.2.1.1 System Operating Techniques

Operating the shuttle requires activities by the spacecraft crew in addition to the shuttle crewman's duties. Whether a mission is accomplished with the shuttle, by maneuvering the spacecraft, or by crewmen in space suits, the spacecraft commander must plan the activity to give the necessary lead time for crew and vehicles to be prepared. In this planning, due consideration to eclipse periods and to the radiation environment is required. While the shuttle is away from the primary vehicle, a station crewman will be assigned to track the shuttle, to maintain communications with the shuttle crew, and to monitor the operation for emergencies. The spacecraft commander will also operate the station to facilitate the shuttle operation for docking and tracking.

3.2.1.2 Effect on Primary Vehicle Design

The primary station serving as a base for shuttle vehicles must provide docking and stowage facilities for the shuttle. A non-rotating station could accept a shuttle by the addition of another hatch similar to those usually proposed for the docking of the earth-to-orbit ferry vehicle. A small station on which hatch space is at a premium could utilize the same hatch for ferry and shuttle but with the shuttle stowed on a boom to position it over the hatch, keeping the shuttle from drifting about while not in use. Rotating stations present an additional problem in that space on a non-rotating hub is usually scarce, and attaching shuttles to rotating parts introduces balance and control problems as the shuttles come and go. Very large stations are expected to have hangar facilities, thus simplifying the maintenance work on the shuttle itself, but the shuttle again competes for space with other devices.

The primary station must also provide stowage space for shuttle propellant, spare parts and special tools. It is expected that the life support consumables will be provided for the crewman whether the shuttle is present or not. These demands are anticipated to be trivial compared to the total requirements of the space station.

3.2.1.3 Number of Shuttles Required

The number of shuttle vehicles based at a primary station is a function of the missions expected to be performed. A minimum, of course, is one shuttle plus the necessary spares to keep it operational. However, it is recommended that two shuttles plus spares be regarded as a minimum for operational missions to provide both a back-up and a rescue capability. For missions requiring the assembly of large components, additional shuttles are required; for instance, transporting a booster stage equivalent to an S-IV requires four shuttles of the type proposed in Section 6. An additional shuttle would be desirable for the assembly foreman who would direct the entire operation.

3.2.2 Emergency Situations and Procedures

The various hazards confronting the operator of a shuttle and the proposed counteracting procedures and design features are discussed in this section.

The fundamental problem of equipment reliability is discussed at greater length in Section 6.13. The problem discussed here is the technique for dealing with the occasional failures. The most likely hazards and the six types of ensuing events are summarized in Table 3-5. The hazards considered are: damage to the shuttle itself, failure of the shuttle systems, depletion of consumables, and accidents to the primary or to the astronaut. Losing contact with the primary is classified as an accident. Having encountered an untoward event, the probability of each of the six following events occurring is estimated in the table. The first consequence considered is that of complete destruction. Events considered to be catastrophic are fires, explosions, and loss of oxygen. In each of these cases it is considered very unlikely that the astronaut would survive. The next alternate considered is that the astronaut returns to the primary in the shuttle in spite of the damage which has occurred. It is expected that this would occur following such accidents as small meteoroid punctures

TABLE 3-5
HAZARD AND ESCAPE MODES

SHUTTLE HAZARDS	CATASTROPHY (P)*	RETURN TO PRIMARY (P)	REPAIR BY ASTRONAUT (P)	RESCUE BY EARTH PRIMARY		REENTRY
				(P)	(P)	
<u>Shuttle</u>						
Puncture	a**	A	A	a	A	a
Fire	A***	a	a	a	a	a
Explosion	A	o	o	o	o	a
<u>Systems Failure</u>						
Electrical	a	a	A	a	A	a
Mechanical	a	A	A	A	A	a
Communications	a	A	A	A	A	a
Propulsion	a	a	A	A	A	a
Control	a	a	A	A	A	a
<u>Others</u>						
Out of O ₂	A	o	o	o	o	a
Out of propellant	a	o	o	A	A	a
Primary destroyed	A	o	o	a	o	A
Astronaut injury	a	A	A	a	A	a

*P = probability

**a = very small number

***A = 1 - a

when the astronaut is suitably protected by a pressure suit, electrical, mechanical, and electronic failures in non-essential systems. Another alternative considered is that the damage or malfunction is repaired by the astronaut to the extent necessary to permit his return to the primary. Many of the shuttle subsystem malfunctions are expected to be in this category. The next category considers events which prohibit the passage of the shuttle to the primary, but which do not affect the life support systems. In this case, the astronaut may be rescued by another shuttle, by the primary, or by an earth-launched rescue vehicle. However, the latter is considered unlikely unless reserves of over 12 hours are provided in the shuttle and a rescue vehicle is kept on permanent alert on earth. The last consideration listed is that of reentry of the shuttle. Given a vehicle capable of reentry, but which has sustained some damage, it is difficult to imagine a situation in which reentry and recovery in a timely manner are less hazardous than returning to the primary or awaiting rescue by the primary. The sole situation in which reentry seems indicated is that of destruction of the primary, but all primaries proposed to date have provisions for a stand-by emergency reentry vehicle, and it is anticipated that this vehicle would also be able to pick up the shuttle crewman who happened to be absent when the accident to the primary occurred.

3.2.3 Maintenance, Repair and Upkeep - Design Philosophy

The shuttle is designed to be maintained in orbit. It is anticipated that it will never be returned to Earth for overhaul or refurbishment.

Major on-board systems requiring periodic maintenance are:

- Environmental Control System**
- Communication System**
- Rendezvous Radar System**
- Autopilot**
- Battery Power Supply**
- Propulsion System**
- Lighting System**
- Instrumentation**

Landing Gear
Primary Structure
Removable Hatches
Windows
Expandable Shelter

The maintenance design philosophy is to modularize all systems to permit maintenance on the replacement basis. The technique is to attach the shuttle to the home space station by means of the hatch frame. Maintenance on internal systems may be conducted through the hatch in a shirtsleeve environment. There are certain functions which may not be performed inside for safety reasons. Replenishment of propellants and high pressure gases must be done externally. It is proposed that such replenishment be accomplished by an umbilical system which may be remotely connected and disconnected. Replacement of any component of the propellant system must also be performed externally to avoid possibility of leakage of propellant fumes into the space station atmosphere. Propellant and high-pressure gas components will be replaceable by a plug-in technique. Nitrogen purge through overboard drain will be provided. All seals will be attached to the removable module. Certain problems exist in regard to leak detection and system functional checking in space. These must be the subject of further study.

Maintenance operations are generally in four categories:

1. Each flight
2. Short term periodic
3. Long term periodic
4. As needed

Major functions required for each flight are:

- a. Replenishment of propellants
- b. Recharge batteries
- c. Replenishment of ECS supplies
- d. Replacement of adhesive pads on landing gears

- e. Replenish ECS water
- f. Replenish ECS O₂
- g. Replace lithium hydroxide canister

Major items requiring short term periodic maintenance are:

- a. Replacement of electronic modules because of deterioration of semi-conductors, insulation, etc.
- b. Replacement of thrusters
- c. Replacement of valves, regulators, etc., in propellant systems and other fluid systems
- d. Clean ECS traps

Major items requiring long term periodic maintenance are:

- a. Replace ECS module
- b. Replace screw jacks, motors in grapplers
- c. Replace wire bundles
- d. Check fixed-plumbing systems for leaks, cracks, corrosion, etc.
- e. Inspect structure for leaks, punctures, corrosion, cracks, etc.

Major "as-needed" maintenance tasks include:

- Repair meteoroid punctures
- Repair collision damage to structure, windows, antennas, thrusters, grapplers, etc.
- Repair plumbing leaks
- Replace ECS modular components which malfunction

It is estimated that three test plugs totaling approximately 100 pins are required for internal system checkout. These plugs are accessible internally in a checkout panel.

3.2.4 Shuttle Operating Techniques

The operational techniques required to perform the missions are discussed

in this section. In the course of this investigation, specific design problems for each stage of the mission are defined, and the special equipment needed for each operation is specified.

An assembly mission consists of two distinct phases, that of transporting each component to the assembly site and that of joining and checking out the assembled components. Transporting large components by a single shuttle introduces problems of vision, of c. g. alignment, and of exhaust clearance. Solving these problems by building shuttles comparable in size to the components being considered results in shuttle vehicles that are both uneconomical and impractical for the other shuttle missions. A technique is, therefore, presented for using smaller shuttles that are designed for the less demanding missions to accomplish the transport of large components. The technique is illustrated in Fig. 3-15 which shows how four shuttles are arranged around a stage comparable to the S-IV to provide vision for the shuttle crews, adequate thrust for the mass being moved, and to use the primary propulsion systems of the shuttles for attitude control. Coordinating the efforts of the several shuttles is done by a lead crewman who transmits control commands to the other shuttles by radio. These commands are then executed by the crewmen of the individual shuttles. No equipment other than that normally provided in each shuttle is required.

The procedures for making the structural joint between modules follow those recommended in Ref. 3-3, Study of Space Maintenance Techniques (SMT). The shuttles assigned to this task carry the appropriate welding, riveting, or special tools for the particular type of joint employed. Heavy duty manipulators capable of positioning the massive modules accurately against large friction or latching forces are provided to eliminate the need for dynamic docking. Likewise, particular attention should be given to manipulators for connecting fluid lines to avoid exposing the crew to the hazards of spilling toxic fluids. The shuttle crewman makes visual inspections of the joints, load tests using the manipulators where indicated, continuity checks, and such functional checks not provided for by the vehicle systems.

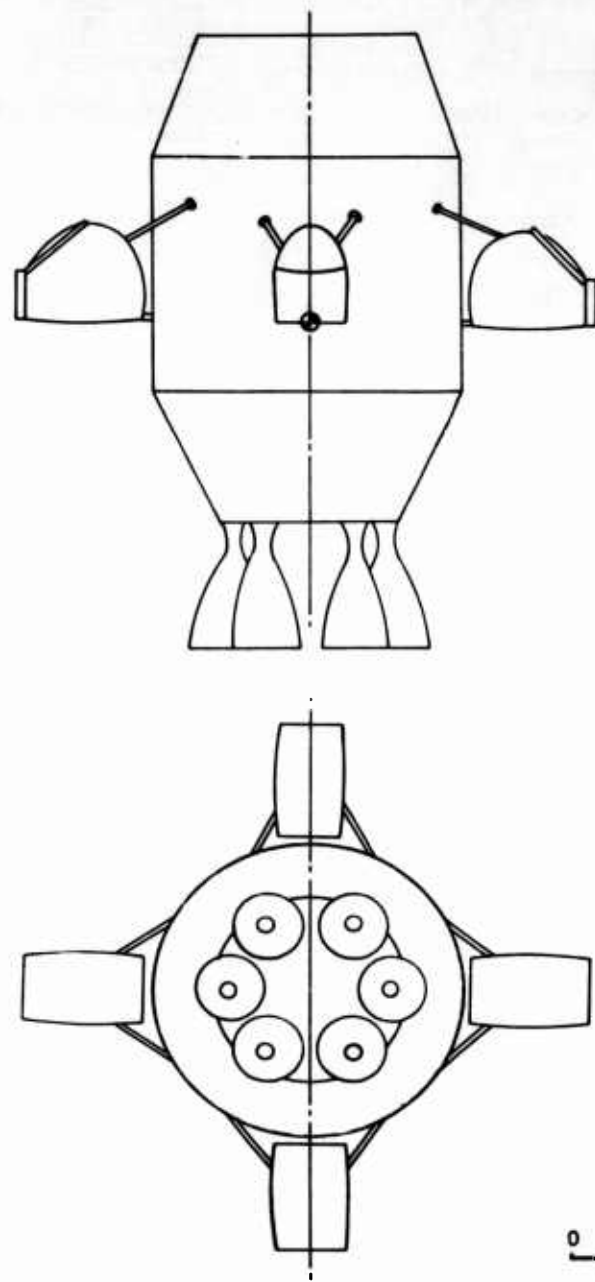

FIG. 3-15 BOOSTER TRANSPORT

In practice, maintenance is performed on a scheduled basis for the purpose of preventing failures, and repair is performed as required to return a failed system to operational status. The choice of the technique to be used in any particular situation depends on the nature of the system, the consequences of down-time, and the availability of maintenance facilities. In general, the equipment provided in the shuttle is similar for each technique, and the operations performed by the crewman on any particular mission might include both the checkout procedures identified with the maintenance technique and the repair procedures necessary to correct faults. Therefore, the following analysis applies equally to both techniques.

Various levels of maintenance may be expected in space operations analogous to the field repair, the base repair, and the depot levels of maintenance found on Earth-bound systems. Some repairs might be made on an unmanned satellite on station in orbit. Repairs requiring techniques or equipment too complex to be performed by a single crewman in the shuttle may be done by bringing the satellite or the faulty component to the primary which serves as a maintenance base. The checkout of the repairs may be performed either by the shuttle, by transmitting data to the primary, or transmitting data to the Earth station with which the satellite normally communicates. Only on-site maintenance operation is discussed here as the technique of returning to the primary becomes transport missions for the shuttle rather than repair missions.

Five methods of performing work on the target satellites are considered. In the first the entire satellite, if it is small enough, or the faulty component, is taken aboard the shuttle and the repair work is done in the pressurized capsule where the crewman has access to the required spare parts and tools. The second, the hatch arrangement, achieves the same desirable working conditions, but eliminates the need for opening the shuttle to space to take aboard the work piece by latching the shuttle to a mating hatch in the satellite and pressurizing both the satellite and the shuttle. This requires, of course, that the shuttle and satellite be designed to cooperate in this manner, a condition

which severely restricts the application of the technique. The third, the shelter technique, protects the crew from the meteoroid hazard, from the thermal and visual difficulties of operating in alternate sunlight and shadow, and against loss of articles dropped in space. To avoid designing a hatch into the target vehicle, the crewman must work in a pressurized suit. The fourth method simply provides the crewman with sleeves by means of which he reaches through the wall of the shuttle to perform his repair and maintenance operations. Experiments performed to evaluate this technique are described in para. 5.4. The fifth method provides complete protection, but replaces the crewman's arms with mechanical manipulators and associated power and control devices necessary to operate them.

The repair and maintenance mission may require the shuttle to work upon satellites at points where no latching or docking mechanism is provided. Four techniques for accomplishing this task are considered. The first side-steps the problem by providing the ability to hover beside the work station while the crew performs the maintenance job. The second technique uses the short landing gear legs illustrated on the configuration drawing to stabilize the shuttle by attaching to the surface of the target by adhesive pads. Exploratory tests on two types of readily available adhesive tapes were made in the Lockheed Rye Canyon facility. The results are summarized in Table 3-6 and indicate that vacuum effects may be tolerated for this application. Radiation and temperature effects have not been studied to date.

The third technique utilizes nylon straps and inflated bumpers on the shuttle to maintain the relative positions of target and shuttle. Almost all targets will be provided with hand holds and lift lugs for the normal fabrication and handling requirements, and wherever possible, the straps will utilize these hard points. Simple hooks or eyes on the ends of the straps are used for attachment. For those vehicles for which no suitable attachments are installed, it is expected that a structural member of adequate strength will be available in which a small hole can be drilled and a pip pin or Cleco fastener inserted to anchor the straps.

TABLE 3-6
VACUUM TESTS OF ADHESIVE TAPES
Tension Stress at Failure psi

Specimens: Minnesota Mining and Manufacturing

Specimen and Size	1	2	3	4	5	Average
Ambient						
<u>Y9002 3/4 x 3/4</u>	46.2	51.5	53.2	55.0	58.5	53.0
400 1 x 1	46	44	50	47		45.8
Eight hr 3.6×10^{-6} to 6.8×10^{-6} Torr						
<u>Y9002 - 3/4 x 3/4</u>						
Backing removed	24.8	32.0	40.8	33.7	23.1	30.5
Backing intact	All failures on side exposed					21.8
400 1 x 1						
Backing removed	27	36	37	39	44	36.6
Backing intact	32	31	35	31	37	33.2
Four of five failures on exposed side						
41 hrs. @ 4.2×10^{-6} to 3.2×10^{-7} Torr						
<u>Y9002 3/4 x 3/4</u>						
Backing removed	56.7	64.0	64.0	48.0	53.3	57.0
Backing intact	56.7	56.7	58.6	49.7	51.5	54.7
400 1 x 1						
Backing removed	46	38	25	42	43	38.8
Backing intact	48	35	41	43	39	41.3
Four of five failures on exposed side						

The fourth method utilizes a band and a bumper on the shuttle. The band is normally coiled on a reel with the free end anchored to the shuttle. By unreeling this band, a loop is formed which may be maneuvered over the target and then cinched by the reel. The band might be either a steel tape or a fabric tube inflated with gas.

The cargo transport mission is similar to the transport phase of the assembly mission, but the modules to be handled are generally smaller to facilitate their handling on the ground, in the launch vehicle, and the space station. Lockheed studies of space stations indicate that modules approximately 3 x 5 x 5 ft, weighing 1250 lb are the maximum size that can be conveniently handled inside of a space station. The shuttle, however, could transport two such packages, latched or strapped together temporarily, into a 5 x 5 x 6 module. This is the technique considered for the 2000 lb resupply mission of Table 2-3. The choice of package size is governed by storage and handling facilities in the ferry vehicle and in the space station rather than by shuttle capabilities. The need for standardized packages, lift lugs and handling techniques is evident.

An example of a personnel transport mission is carrying specialists, such as doctors or scientific specialists, from one space station to another. In this case the specialist would be expected to fly the shuttle himself, so there is no need for a pilot-plus-passenger arrangement. A second application of the personnel transport capability is the rotation of crew members from a permanent station to the earth-to-orbit ferry. The shuttle is normally based at the station. One of the members leaving the station would fly the shuttle to the ferry, his replacement would return in the shuttle to the space station. This process continues until all members have been transferred, and again there is no need for a pilot-plus-passenger capability in the shuttle.

As space activities are expanded it is anticipated that personnel other than replacement crew members will visit the station, and the 1- to 1-relationship of rotating personnel will no longer exist. It is also likely that many of these transients will not be trained shuttle pilots. Several alternates for the transport

of multiple passengers are available. A shuttle large enough to carry one or more passengers in addition to the pilot results in a shuttle unnecessarily large for most other missions. A third alternative is to provide a pressurized cabin, large enough to house the number of passengers expected, which is towed by the shuttle. This cabin may take the form of an inflated bag, a section of the ferry or station which is detachable, or a module that is to be attached to the station to expand its capabilities. The cabin may have its own environmental control and life support system if the number of missions justifies such complication.

The rescue mission is a special case of the personnel transport mission. To be effective, the shuttle used for rescue purposes would be maintained on an alert status and be capable of rapid transfers. The ability to house the person rescued inside the shuttle is desirable, as a need for rescue implies a need for first aid and minimum exposure to space.

An inspection mission requires only the ability to reach the target and the ability to carry whatever special equipment is used for the inspection. Those inspection missions that involve closing with an uncooperative target that is capable of evasive action are not included in this study.

The Lockheed-California Company is studying methods of docking with spinning satellites as part of the Orbital Attachment and Docking Validation Parameters study being performed for ASD. The first quarterly progress report (Ref. 3-4), LR 16931 presents the findings of this study to date. The conceptual design studies that have been performed are briefly summarized here in view of the importance to the shuttle concept of being able to cope with run-away attitude control systems in the target vehicle.

1. Shuttle assumes coaxial spin rate equal to target's, grapples with target, and stops rotation with shuttle attitude control system. This technique is limited by the effects on the crewman.
2. A lanyard is carried by pressure jets in its head to encircle the vehicle and brake the rotation by friction. Structural problems and the danger of wrap-around are the major difficulties expected with this method.

3. De-spinning is accomplished by physically bumping the target with suitable shock absorbers or bumpers on the shuttle.
4. Enveloping the target with an umbrella-like device remotely controlled from this shuttle. The device de-spins the target with a reaction control system once attached.
5. Similar to (4), but using an unmanned bug which attaches itself to the target.
6. Magnetic and eddy-current devices.
7. A boom on the shuttle is rotated to match the spin of the target and attaches to the target at a point on the spin axis. A mechanical brake and the shuttle's reaction control system are then used to de-spin the target.

3.3 MISSION PERFORMANCE

This section presents the performance of the shuttle when applied to each of the missions defined in Section 2.3. Specific tasks at each stage of the missions are identified. The design implications and their effect on the propellant and on-board power requirements are established. The integrated results are used to define design duration, tankage, and power requirements.

3.3.1 Vehicle and Mission Parameters

The parameters defining the vehicle and mission upon which this analysis is based are summarized in Table 3-7.

Shuttle design data used is typical of the configuration presented in the Preliminary Design Study, Section 6. The single value of shuttle weight is used for all missions as the variations in empty weight caused by changes in equipment do not affect the results significantly. Similarly, the moment of inertia about the pitch axis is used as this is expected to be used most frequently. The shuttle has nearly the same moment of inertia about the other axes.

The attitude control propellant is based on a limit cycle operation while coasting or hovering, and on a series of attitude changes. Each change is called a maneuver and consists of accelerating the vehicle to an angular velocity of 10 deg/sec, coasting to the desired position, and stopping the motion. This rate, corresponding to one revolution in 36 sec, is considered fast enough to be useful, and is only half the rate expected to be upsetting to the pilot.

The analysis considers ranges of 6.7, 13.4, and 20 n. mi. , covering the maximum values considered in section 3.1.2. The most difficult primary-target orientation is also assumed.

The out-bound flight of the shuttle from the primary to the target is always made without cargo, while the return flight is generally at a much higher gross weight. At the high weights, fast transfers require awkward amounts of propellant. The technique used, therefore, is to always make the

Table 3-7

VEHICLE AND MISSION PARAMETERS

		Code Number
Shuttle empty weight	800 lb	
Shuttle pilot	200	
Shuttle inert weight	1000	
Shuttle moment of inertia	100 slug ft ²	
Shuttle + 2000 lb cargo moment of inertia	1000	
Shuttle + 6700 lb cargo moment of inertia	5000	
Thrust	200 lb	
Thruster moment arm	6 ft	
Specific impulse, propulsion	300 sec	
Specific impulse, attitude	240 sec	
Propellant per attitude change @ 10 deg/sec		
Shuttle alone	0.0243 lb	
Shuttle + 2000 lb	0.243	
Shuttle + 6700 lb	1.215	
Propellant usage in ±10 deg limit cycle	0.0417 lb/min	
Propellant usage in ±1 deg limit cycle	0.417 lb/min	
Electrical Power		
Attitude control	85 watts	1
Environmental control		
Cabin	35	2
Suit Compression	50	3
Voice communication	5	4
Radar		
20 n.mi. range	100	5
6 n.mi. range	25	6
Illumination		
Interior	20	7
Exterior	100	8
Instruments	5	9
Grapplers	100	10
Ferret test set (para. 3.1.3)	30	11
Common systems test set (para. 3.1.3)	17	12

outward flight near the minimum reasonable time, and to adjust the inbound time to suit the payload and propellant supply. The data of Fig. 3-10 is cross plotted in Fig. 3-16 to facilitate the selection of these transfer times for the conditions considered here. The cutoff at $T/t = 1/2$ represents the minimum time possible with the 200-lb thrust provided, as half the time is used in accelerating, and half in braking. This, of course, is an ideal situation, not exact for all transfers. The techniques used for each mission are summarized in Table 3-8.

Table 3-8

DESIGN MISSION OPERATIONS

MISSION	DESIGNATION	MANEUVER
Training		Maneuver in neighborhood of primary
Material Transfer 2000 lb cargo 20000 lb cargo	A	Traverse out in 600 sec, return with 2000 lb in 1200 sec a) Traverse out in 600 sec, return with 6700 lb package. Make 3 trips (or 3 shuttles) b) Use three shuttles return with 20,000 lb package in 2400 sec.
Personnel Transfer Rotate 10 men	B	a) Five round trips carrying two men (pilot plus passenger) each way. Each traverse 1200 sec. b) One trip with ten men in capsule each way.
Maintenance Station maintenance Unmanned satellite	C	Hover around station, make external repairs Both out and return trip in 600 sec.
Assembly	D	Four shuttles go out to target in 600 sec, return with S-IV in 2400 sec.

SHUTTLE + PILOT WEIGHT = 1000 POUNDS
 $I_{sp} = 300$ SEC

PAYLOAD RANGE	N.M	CURVE
NONE	6.7	1
	13.4	2
	20.	3
2000 LB	6.7	3
	13.4	4
	20.	6
6700 LB	6.7	5
	13.4	7
	20.	8
30,000 LB	6.7	9
	13.4	10
	20.0	11

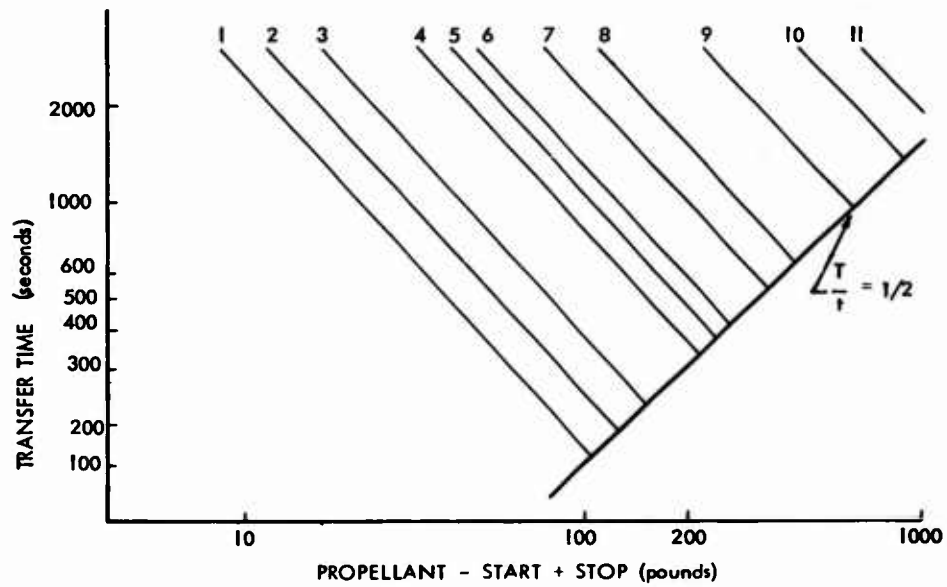

FIG. 3-16 TRANSFER TIME VS PROPELLANT

3.3.2 Preflight and Flight Segments

A detailed analysis of the mission segments involving the flight of the shuttle is presented in this section. For each operation, the systems in operation, the time, the propellant, and the electrical power required are listed. The analysis is performed for the preflight segment, the take-off and cruise-out from the primary, and the return flight segments and these are then combined to form the various missions. As the operations performed during the return flight are similar to those of the out-bound flight, a step-by-step analysis is not repeated, but the effects of the differing ranges and traverse times on the propellant and electrical power are evaluated for each combination considered. The techniques of handling large payloads with multiple shuttles are investigated for several shuttle configurations and for several operational techniques. The sequence of events for the preflight activities is given in Table 3-9. Take-off and cruise-out sequence is shown in Table 3-10, and the return segment propellants and electrical powers are in Tables 3-11 and 3-12.

3.3.2.1 Electrical Requirements - Return Segment

The return segment involves maneuvers similar to the out-bound segment, but with longer intervals between maneuvers. The power requirements are, therefore, found from the take-off and cruise-out analysis by adjusting the power used in the coast period.

3.3.2.2 Assembly Mission - Transport Phase

Generally, the mission consists of manned shuttles operating from a primary vehicle, capturing a passive S-IV booster, and transporting it to the immediate vicinity of the primary. To determine the ability of various shuttle configurations to perform the mission, translation and attitude control engines were located and sized for thrust commensurate with human factors and practical design criteria. Groups of two or four shuttles were selected to perform the assembly mission, thereby providing data to compare the relative merits of the representative configurations. The attitude control system is assumed to be hypergolic, pulse modulated, and capable of a minimum pulse width consistent with the present state-of-the-art.

Table 3-9
PRE-FLIGHT ACTIVITIES

	Δt (min.)	Elapsed Time (min.)	Systems Operating *	Power	
				watts	watt·min
<u>Replenish</u>					
1 Fill N ₂	5	5	7	20	1100
2 Replace LiOH	3	8	↑	↑	
3 Fill H ₂ O	3	11	↑	↑	
4 Replace Adhesive on Pads	3 x 3 = 9	20	↑	↑	
5 Replace Batteries	10	30	↑	↑	
6 Fill O ₂	5	35	↑	↑	
7 Fill Oxidizer	10	45	↓	↓	
8 Fill Fuel	10	55	7	20	
<u>Checklist</u>					
9 Hatch Lock	0.2	0.2	7,9	25	55
10 N ₂ Pressure	0.2	0.4	↑	↑	
11 Fuel Quantity	0.2	0.6	↑	↑	
12 Fuel Temperature	0.2	0.8	↑	↑	
13 Oxidizer Quantity	0.2	1.0	↑	↑	
14 Oxidizer Pressure	0.2	1.2	↑	↑	
15 O ₂ Temperature	0.2	1.4	↑	↑	
16 O ₂ Pressure	0.2	1.6	↑	↑	
17 Cabin Pressure	0.2	1.8	↑	↑	
18 CO ₂ Concentration	0.2	2.0	↓	↓	
19 Voltage	0.2	2.2	7,9	25	
20 Auto Control System	1.0	3.2	1,7,9	110	110

* See code number in Table 3-7

Table 3-9 (cont'd)

PRE-FLIGHT ACTIVITIES

	Δt (min.)	Elapsed Time (min.)	Systems Operating	Power	
				watts	watt·min.
Checklist					
21 Clock	1.0	4.2	1, 7, 9	110	110
22 Radar	3.0	7.2	1, 6, 7, 9	135	405
23 Radio	0.2	7.4	1, 4, 6, 7, 9	140	1180
24 Hook-up Suit	1.0	8.4	↑	↑	
25 Hook-up Belt	0.2	8.6			
26 Suit Ventilation	1.0	9.6	↓	↓	
27 Suit Pressurization	1.0	10.6			
28 Flight Plan	3.0	13.6			
29 Fire Each Engine	2.0	15.6	1, 4, 6, 7, 9	140	
					2960
					49 watt·hr

Table 3-10
TAKE-OFF AND CRUISE-OUT
1000 lb Shuttle - No Payload

	Δt (min)	Elapsed Time (min)	Propellant		Power		* Systems Operating
			Main (lb)	Attitude (lb)	(watts)	(watt·min)	
Release legs	0.2	0.2			350	70	1, 2, 4, 7, 8, 9, 10
Backout-100 lb thrust	0.02	0.2	0.43	0.43	250	5	1, 2, 4, 7, 8, 9
Approximate orientation, 3 maneuvers	1	1.2		0.08	250	250	
Radar search, Limit cycle 1 deg	1	2.2		0.42	175	175	1, 2, 4, 6, 7, 9
Take-off orientation, 3 maneuvers	1	3.2		0.08	250	250	
Main propulsion	0.417	3.62	16.5		175	73	
Limit cycle 10 deg	1.50	5.12		0.06	170	255	1, 2, 6, 7, 9
Mid-Course Correction							
Correct. #1 30 fps		5.12	3.1	0.02			
Limit cycle 10 deg	1.50			0.06	170	255	
Correct. #2 10 fps	1.50	6.62	1.03	0.02	170	255	
Correct. #3 7 fps		8.12	0.72	0.02			
Limit cycle 10 deg	1.50			0.06	170	255	
Correct. #4 5 fps		9.62	0.52	0.02			
Limit cycle 10 deg	1.50			0.06	170	255	
Correct. #5 3 fps		11.12	0.31	0.02			
Limit cycle 10 deg	1.70			0.07	170	289	
Correct. #6 25 fps		12.82	2.6	0.02			
Braking	0.417	13.24	16.5		175	73	1, 2, 4, 6, 7, 9
Park-six maneuvers	3	16.24		0.15	250	750	1, 2, 4, 7, 8, 9
			41.71	1.59			3206
			43.3 lb				53.4 watt·hr

* See code number in Table 3-7

Table 3-11
PROPELLANT REQUIREMENTS
RETURN TO PRIMARY MISSION SEGMENT
Single Shuttle

Payload Traverse Time	None 600	2000 1200	6700 2400	200 1200
Range 6.7 n. mi.				
Total Thrusting Time (sec)	50	56	74	33
Main Propellant	33	37	49	22
*Guidance Propellant	8	16	54	10
**Maneuvers	1.3	13	65	1.5
***Limit cycle 1 deg	0.5	2.5		0.5
10 deg	0.5	2.5		0.5
	<hr style="width: 50px; margin: 0 auto;"/>	<hr style="width: 50px; margin: 0 auto;"/>	<hr style="width: 50px; margin: 0 auto;"/>	<hr style="width: 50px; margin: 0 auto;"/>
	43.3	71.0	168	34.5
Range 13.4 n. mi.				
Total Thrusting Time	69	105	138	45
Main Propellant	46	70	92	30
Guidance Propellant	16	32	108	20
Maneuvers	1.3	13	65	1.5
Limit Cycle 1 deg	0.5	2.5		0.5
10 deg	0.5	2.5		0.5
	<hr style="width: 50px; margin: 0 auto;"/>	<hr style="width: 50px; margin: 0 auto;"/>	<hr style="width: 50px; margin: 0 auto;"/>	<hr style="width: 50px; margin: 0 auto;"/>
	64.3	120.0	265	52.5
Range 20 m. mi.				
Total Thrusting Time	100	158	195	66
Main Propellant	67	105	130	44
Guidance Propellant	24	43	162	30
Maneuvers	1.3	13	65	1.5
Limit Cycle 1 deg	0.5	2.5		0.5
10 deg	0.5	2.5		0.5
	<hr style="width: 50px; margin: 0 auto;"/>	<hr style="width: 50px; margin: 0 auto;"/>	<hr style="width: 50px; margin: 0 auto;"/>	<hr style="width: 50px; margin: 0 auto;"/>
	93.3	166.0	357	76.5

*Proportional to range, weight
**Proportional to moment of inertia
***Proportional to coast time/moment of inertia

ELECTRICAL REQUIREMENTS - RETURN SEGMENT

Transfer Time	600 Base	1200	2400
Time increment sec	--	600	1800
Time increment min	--	10	15
Base watt-min	3206	3206	3206
Coast wattage	115	115	115
Coast watt-min increment	--	1150	1725
Total	3206	4356	4931
Watt hrs	53.4	72.6	82.2

Maneuvers are performed at 20 deg/sec or the maximum angular velocity available with the configuration considered, whichever is greater. The attitude control propellant is practically the same for each configuration if the same angular velocities are used.

Limit cycle operation uses negligible propellant with the high moment of inertia payload.

Table 3-13

ASSEMBLY MISSION FUEL EXPENDITURES

Shuttle Maneuver	Attitude Jets Only	Attitude + Main Engines			
	4 Shuttles	4 Shuttles			2 Shuttles
	Platform	Minimum	Boom	Platform	Platform
Attitude control fuel (lbs)	84.6	71.0	97.4	300.8	145.8
Translation fuel (lbs)	774.8	774.0	773.4	774.8	735.4
Total fuel required (lbs)	859.0	815.0	871.0	1075.0	881.0

The data above, which compares the performance of several configurations, is modified to apply the platform shuttle to the design mission. Results are given in Table 3-14

Table 3-14

**PROPELLANT REQUIREMENTS
MISSION SEGMENT - RETURN TO PRIMARY**

Four Shuttles, 117,000-lb payload

Range	Traverse Time (sec)	2400 sec	
		Total	Per Shuttle
<u>Range 6.7 n. mi.</u>			
Burn time, sec	590	405	
Main propellant	395	270	
Maneuvers	100	100	
Limit cycle	Negligible		
Total	495	370	92.5
<u>Range 13.4 n. mi.</u>			
Burn time, sec	1125	795	
Main propellant	750	530	
Maneuvers	100	100	
Limit cycle	Negligible		
Total	850	630	157.5
<u>Range 20 n. mi.</u>			
Burn time, sec		1170	
Main propellant	Not possible	780	
Maneuvers	With 200 lb	100	
Limit cycle	Thrust/shuttle	Negligible	
Total		880	220

3.3.3 Functional Segments of the Mission

The sequence of events and resulting propellant and electrical power requirements are presented for the mission phases concerned with performing the design assignment. The missions which consist entirely of transport are covered in the preceding section as the tasks of docking, attaching to the payload, and depositing it at its destination are covered by the terminal maneuvers included therein. In this section, the training mission, the station repair mission and the repair of unmanned satellites are discussed in detail. An estimate of the

assembly and check-out task is made, but lack of details concerning the design of the components to be mated prohibits a more refined analysis.

3.3.3.1 Functional Mission Segments-Training

The type and sequence of maneuvers performed in the training and experimental missions are a function of the particular experiment, e. g. , tests of vehicle handling, rendezvous technique, or guidance equipment. A shuttle with tanks sized for operational missions has adequate capability for training; however, the propellant carried is expected to be limited by the launch vehicle, and this governs the extent of experiments possible.

The electrical power requirements in watts are:

	<u>Continuous</u>	<u>Flight Experiments</u>	<u>Docking Experiments</u>
Attitude control		85	
Cabin environmental control	35		
Voice communication	5		
Radar (or other system for test)		25	
Interior illumination	20		
Instruments	5		
Grapplers	—	—	<u>100</u>
	65 . atts	110 watts	100 watts

An arbitrary training mission to estimate battery requirements is

	<u>Time (hours)</u>	<u>(watt · hours)</u>
Total mission continuous	5	325
Radar operation	3	330
Docking-grapppler operation	1/2	<u>50</u>
		705

3.3.3.2 Station Repair Mission

The task considered is that of performing extra-vehicular repairs on a large space station. Typical tasks include the repair of meteoroid damage, the replacement of solar cell elements, the servicing of mechanisms for positioning solar arrays and antennas, and repair of electrical elements of these devices. Routine servicing of mechanisms is expected, and provision of suitable hand points for securing maintenance workers is anticipated. The hovering capability of the shuttle is utilized when damaged areas are too delicate to support a maintenance worker. Although only exterior damage is considered for this task, the local geometry, especially in congested areas such as engine installations, may involve serious access problems. The mission segment analysis of Table 3-15 is therefore based on use of the shelter technique. The analysis assumes that a switch repair is required and that an inspection for meteoroid damage is made before returning.

3.3.3.3 Unmanned Satellite Repair

Reconnaissance satellites incorporate both complex sensing systems and data processing and transmission systems, thereby creating difficult maintenance tasks. The analysis of the unmanned satellite maintenance task is, therefore, based on the reconnaissance type.

Detailed procedures for the maintenance, fault isolation, and fault correction of future reconnaissance satellites are not available. An estimate of the probable complexity of the task is possible, however, by considering the procedures prescribed for the equipment installed in the P-3A aircraft. A few of the systems and the number of operations listed in the maintenance manuals are shown in Table 3-16. It is expected that satellites intended for in-space maintenance will be designed to permit remote diagnosis from the ground or a space station, to restrict repair and replacement to subsystem modules rather than detail components, and to be physically arranged for easy access to checkpoints. Even so, providing for 500 operations at an average of half-a-minute each appears necessary for a complete system check. The shuttle residence at the satellite of over four hours also allows, in some cases, two passes over

Table 3-15

STATION REPAIR

	t (min)	Elapsed Time (min)	Propellant		Power		* Systems Operating
			Main (lb)	Attitude (lb)	watts	watt- min	
Release legs	0.2				350	70	1, 2, 4, 7, 8, 9, 10
Back-off	0.02			0.048	250	5	1, 2, 4, 7, 8, 9
Two maneuvers		0.2					
Fly to fault area	2			0.146	250	500	1, 2, 4, 7, 8, 9
Six maneuvers		2.2					
Park at fault area	0.5			0.073	250	125	1, 2, 4, 7, 8, 9
Three maneuvers		2.7					
Switch to suit pres and 1 deg limit cycle	0.5	3.2		0.208	265	132	1, 3, 4, 7, 8, 9
Open hatch	1			0.417	265	265	1, 3, 4, 7, 8, 9
Replace switch	25			10.42	265	6625	
Per Sect 5.4		29.2					
Functional check	1	30.2		0.417	265	265	
Close hatch	1	31.2		0.417	265	265	
Pressurize cab	2			0.834	265	530	
Inspect station	60			2.43	250	15000	1, 2, 4, 7, 8, 9
100 maneuvers + 1 deg limit cycle		93.2		25			
Park at damage	0.5	93.7		0.208	250	125	
Switch to suit pressure and 1 deg limit cycle	0.5	94.2		0.208	265	132	1, 3, 4, 7, 8, 9
Open hatch	1	95.2		0.417	265	265	1, 3, 4, 7, 8, 9
Install patch per Sect. 5.4	8			3.33	265	2120	1, 3, 4, 7, 8, 9
		103.2					

* See code number in Table 3-7

Table 3-15 (cont'd)

STATION REPAIR

	t (min)	Elapsed Time (min)	Propellant Main Attitude (lb) (lb)	watt	watt- min	Systems Operating
Close hatch	1	104.2	0.417	265	265	1, 3, 4, 7, 8, 9
Pressurize cab	2	106.2	0.834	265	530	1, 3, 4, 7, 8, 9
Fly to station Hatch-six man	2	108.2	0.146	250	500	1, 2, 4, 7, 8, 9
Attach legs	3	111.2	1.25	350	1050	1, 2, 4, 7, 8, 9, 10
Attach hatch	1	112.2		350	350	1, 2, 4, 7, 8, 9, 10
Balance pressure	0.5	112.7		250	125	1, 2, 4, 7, 8, 9
Open hatches Shutdown	2	114.7		250	500	1, 2, 4, 7, 8, 9
			47.22		29,744	495. watt-hr

Table 3-16
TYPICAL MAINTENANCE TASKS
P-3A ELECTRONIC SYSTEMS

Reference NAVWEPS 01-75 PAA 2-9.1 & -6.1

System	Number of Settings or Readings - Functional or Performance Check	Number of Probable Faults	Operations to Isolate and Correct Fault
Radar Recognition Set	51	27	25
Radar Identification Set and AN/APA-89 Coder	46	36	72
Navigation Unit NVA-22A	42	43	104
Transceiver System	40	27	54
Power Amplifier Module (Transceiver)	23	14	14
Translator Module (Transceiver)	17	26	39

the earth station reading the satellite, so two checks on the complete system operation may be made while the shuttle is available for adjustment.

While the satellites are expected to be arranged to accept check-out plugs and replacement modules with the simplest sort of tools and minimum need for access to the interior, the analysis assumes that effecting the repair requires direct visual and manual contact by the crewman. The shelter technique is therefore used. Cleats for attachment of the grappers are assumed, so there is no need for working in the hovering mode. The de-spin operation assumes that the target is comparable in size to the shuttle and that spin rates do not exceed pilot capabilities. The ten standard maneuvers (see para. 3.3.1)

include locating the shuttle to perform the de-spin operation. This mission segment is analyzed in Table 3-17.

3.3.3.4 Assembly Mission

The assembly and checkout segment of the mission is estimated to require one hour at a power level of 220 watts. Each shuttle is assumed to be grappled to the assembly at an assigned attachment point. No propellant is used in this phase.

3.3.4 Design Requirement Summary

The propellant and electrical requirements calculated for the various missions and ranges considered are in Tables 3-18 and 3-19. Providing propellant for a multiple-trip mission requires a vehicle grossly over-sized for other missions. Also, maneuvering objects of 2000 lb and over is awkward for a single operator as such payloads are larger than the shuttle considered. Rather than designing over-sized shuttles for these purposes, it is more attractive to increase the number of small vehicles to operate as teams when necessary. Adopting this approach, 200 lb of propellant is adequate for all but the heavy payload missions. The chart does not include reserve propellant. The reserve quantity is selected by giving the pilot enough propellant over the mission requirement to return without payload from 20 n. mi. in 20 minutes; this amounts to 65 lb for the vehicle considered. Usable propellant of 265 lb is therefore selected as the design value.

The electrical load chart, Figure 3-19, also shows a strong dependence on the type of mission. Requirements are modest except for the maintenance and training mission. Twelve hundred watt hours is recommended to assure adequate power. As most of the power is not required for safety or to operate the vehicle, small reserves might appear tolerable; however, to avoid deep discharges and resulting voltage drops, 100 percent reserve on the 1200 watt hours is recommended.

The mission duration for the cases considered is summarized in Table 3-20. Having eliminated the multiple-trip missions, the maintenance mission dominates.

Table 3-17

MISSIONS SEGMENT - UNMANNED SATELLITE REPAIR

	t (min)	Elapsed Time (min)	Propellant Attitude Control	Power		Systems Operating	
				watts	watt- min		
De-spin - 10 maneuvers	5.0		0.243	345	1725	1, 2, 7, 8, 9, 10	
Fly to attach point	0.5	5	0.073	245	122	1, 2, 7, 8, 9	
3 maneuvers		5.5					
Attach grapples	3.0		1.25	345	1035	1, 2, 7, 8, 9, 10	
1 deg limit cycle		8.5					
Orient for light or thermal control - 6 maneuvers	2.0		0.146	245	490	1, 2, 7, 8, 9	
Switch to suit pressure	0.5	10.5		175	88	3, 7, 8, 9	
Open hatch	1.0	11		175	175		
Open target		12					
Diagnose fault	} 200 50			205	41000	3, 4, 7, 8, 11	
Access to fault							
Repair-replace					192	9600	3, 4, 7, 8, 12
Check-repair							
Check system							
Close target		262					
Close hatch	1.0	263		175	175	3, 7, 8, 9	
Pressurize cab	2.0	265		230	460	1, 3, 7, 8, 9	

Table 3-17 (cont'd)

MISSIONS SEGMENT - UNMANNED SATELLITE REPAIR

	t (Min)	Elapsed Time (Min)	Propellant Attitude Control	Power		Systems Operating
				Watts	watt· min	
Re-establish target orbit	2.0	267	0.146	250	500	1, 2, 4, 7, 8, 9
Retract grapplers	0.2	267.2		350	70	1, 2, 4, 7, 8, 9, 10
			<u>1.858</u>		<u>55440</u>	
					923 watt·hr	

Table 3-18
PROPELLANT REQUIREMENT SUMMARY
 (Propellant in Pounds)

Range	A. Material Transport 2000 lb		B. Personnel Transport 5 Trips		C. Maintenance Station/Unmanned	D. Assembly	E. Training Arbitrary or booster limited
	Outbound and Preflight Maintenance/Assembly	Inbound	Outbound and Preflight Maintenance/Assembly	Inbound			
6.7	Outbound and Preflight	43	43	35	-	43	43
	Maintenance/Assembly	-	-	-	47	2	-
	Inbound	71	168	35	-	43	93
	Total per trip	114	211	70	47	88	136
	Trips	1	3	5	1	1	1
Total per mission	114	633	350	47	88	136	
13.4	Outbound and Preflight	64	64	53	-	64	64
	Maintenance/Assembly	-	-	-	-	2	-
	Inbound	120	265	53	-	64	158
120	Total per trip	184	329	106	-	130	222
	Trips	1	3	5	1	1	1
	Total per mission	184	987	530	184	130	222
	Outbound and Preflight	93	93	77	93	93	93
	Maintenance/Assembly	-	-	-	-	2	-
20.0	Inbound	166	357	77	-	93	220
	Total per trip	259	450	154	-	188	313
	Trips	1	3	5	1	1	1
	Total per mission	259	1850	770	259	188	313
	Transfer Time in bd	1200	2400	1200	1200	600	2400

Table 3-19

ELECTRICAL REQUIREMENT SUMMARY
(watt · hours)

	A. Material Transport		B. Personnel Transport		C. Maintenance		D. Assembly Training	
	2000 lb	20000 lb	5 Trips	1 Trip	Station	Unmanned		
Outbound and Preflight	102.4	102.4	139.5	102.4	-	102.4	102.4	102.4
Maintenance/Assembly	-	-	-	-	495	923	220	705
Inbound	72.6	82.2	72.6	72.6	-	53.4	82.2	
Total per trip	175	184.6	212.1	175	495	1078.8	404.6	807.4
Trips	1	3	5	1	1	1	1	1
Total per mission	175	553.8	1060.5	175	495	1078.8	404.6	807.4

Table 3-20

MISSION DURATION SUMMARY

(In Minutes)

Mission Designation	Mission	Pre-flight	Terminal Maneuver	Outbound Traverse	Inbound Traverse	Terminal Maneuver	Maintenance	Assembly	Total
A	Material Transport 2000 lb	15.6	7.2	10	20	7.2			60
	6700 lb/trip	15.6	7.2	10	40	7.2			80
	20,000 lb/mission (3 trip/mission)								240
B	Personnel Transport Trip/Mission (5 trip/mission)	15.6	7.2	20	20	7.2			70 350
C	Maintenance-station	15.6					114.7		130.1
	Unmanned satellite	15.6	7.2	20	20	7.2	267.2		337.2
D	Assembly	15.6	7.2	10	40	7.2		60	140

A nominal five hours is selected, and reserves for five hours are recommended. Total life support provisions are then adequate for ten hours which is considered desirable for tracking and rescue of a lost or out-of-propellant shuttle.

3.3.4.1 Arrangement Requirements

In considering each step of the design missions, certain requirements for the geometrical arrangement of the shuttle become apparent. The salient features are:

1. Hatch to fit Apollo-Gemini receptors
2. Attitude control about 3 axes
3. Translation along 3 axes
4. Lighting of work and docking area
5. Mount 2-ft diameter (approximately) radar dish with look in all directions (may switch or change attitude)
6. Maneuvering and braking thrust equal to 200 lb each
7. Provide attachment to target, both cooperative and noncooperative.
8. Provision to work on target, gain access to interior and congested areas
9. Vision for rendezvous, docking, working on target, maneuvering with external payload
10. Rocket exhaust impingement on target and shuttle to give harmless temperature and pressure
11. Crew exposure to space hazards to be minimized
12. Man in pressure suit shall have room to stretch. No backpack is required.

3.4 SHUTTLE CONFIGURATION

This section deals with the geometrical arrangement of shuttle components to efficiently accomplish those tasks identified in Section 3.3. Details of subsystem design are discussed in Section 6. Only aspects of subsystem selection which affect the vehicle arrangement are considered here.

3.4.1 Configuration Constraints

All missions considered for the shuttle involve maneuvering close to other vehicles. To be of maximum usefulness, the shuttle must perform regardless of the relative positions of primary, target, payload, Earth, or Sun. It is desirable, therefore, to avoid external appendages and devices which require pointing at the Sun or at dark space. Fortunately, for the power levels and mission durations considered, batteries are simpler and lighter than solar cells or thermal collectors. Likewise, water boilers are a simple and light method for rejecting heat. The complications of solar arrays and radiators are, therefore, eliminated at the outset; the radar antenna remains, however.

The requirement of operating close to other vehicles also imposes the requirement that the rocket engines be so located that neither excessive pressures or temperatures be produced on the neighboring vehicle. Of course, the same consideration applies to the shuttle itself as well as the considerations of thrust, c. g., alignment, engine-out effects.

3.4.2 Configuration Concepts

The requirements to perform the maintenance and transport functions being considered for the shuttle have been recognized by a number of investigators, and various vehicles to satisfy particular aspects of these missions have been proposed. Reference 3-5, Survey of Remote Handling in Space, describes a number of such devices. The maintenance requirements of large space stations have been considered by the designers of the Norair capsule and adapter, the Bell "Remora" and the General Electric capsule. These are all restrained to the immediate vicinity of the parent vehicle by tethers, rails or umbilical cords. A more mobile concept is suggested by Lockheed-Georgia. The two smaller of these designs provide more protection than a space suit, but can carry

little more in the way of tools or equipment. The third is more spacious and equipped for complex missions of longer duration. An adaptation of the Mercury capsule to space maintenance tasks has been suggested. Highly developed manipulators are indicated as the reentry shape of the vehicle is not well adapted to allowing the worker close contact with the satellites to be maintained. The Douglas Humpty Dumpty and Tug represent complex vehicles equipped for almost any eventuality. One of the early proposals, with a most versatile shuttle type vehicle is the LMSC Astro Tug which was described in Reference 3-6 and shown in Fig. 3-17. This vehicle carries a crew of two or more, is capable of long duration missions and is equipped with nearly every type of maintenance device likely to be required. These last two vehicles approach small space stations in their capability and complexity.

Some of the new concepts generated at Lockheed in the course of this study are shown in Fig. 3-18 to 20. The first represents the smallest vehicle that might be useful for the missions specified. This is little more than a hard space suit and is very limited in its application.

The concept of Fig. 3-19 anticipated more extensive missions than were finally considered, the slip-on tanks carry 3,920 pounds of propellant, enough for a ΔV of 7,500 ft/sec. The hanger concept is illustrated in Fig. 3-20; it provides a large pressurized volume in which entire satellites may be repaired. A detachable tractor provides the propulsion system and may operate independently for missions not requiring the hanger. The hanger, of course, might be expandable structure, expanded and rigidized, or a permanent rigid shell. This hanger could also serve as a personnel transport cab for carrying large numbers of people simultaneously with adequate environmental control and protection from the space environment.

Those configurations found to be worthy of more detail investigations are illustrated in Figs. 3-21 and 3-23. The desirable features common to these concepts are freedom from excessive mechanical complexity, provision to give the worker direct access to the parts to be maintained, the capability of carrying

adequate stocks of spare parts and equipment without excessive weight. The configurations differ in the arrangements of the propulsion units and in the techniques of providing access to the target.

The requirement for six degrees-of-freedom motion with precautions against damage to the target or the shuttle from jet impingement exerts a strong influence on the arrangement. The several solutions to this problem represent the major differences between the configurations shown. One solution (shown in Figs. 3-21) is based on the use of multiple, small thrusters, so that only small units need be operated near the target, and the normal shuttle dimensions provide adequate spacing between thrusters and adjacent vehicles. The multiple thruster arrangement has advantages in operational flexibility and reliability. Coupling the thrusters to the attitude control system accommodates a wide range of center of gravity locations, but at a reduction in effective thrust.

Figures 3-22 and 3-23 show arrangements in which the main propulsion engines are placed on a boom behind the cabin. This method incurs trivial propulsive losses when braking and a structural penalty, although total weights are competitive with other types. The configuration shown in Fig. 3-22 is especially intended to locate tools and equipment conveniently in the belt space, while the cabins shown in Fig. 3-23 give the worker using sleeves maximum access to his work.

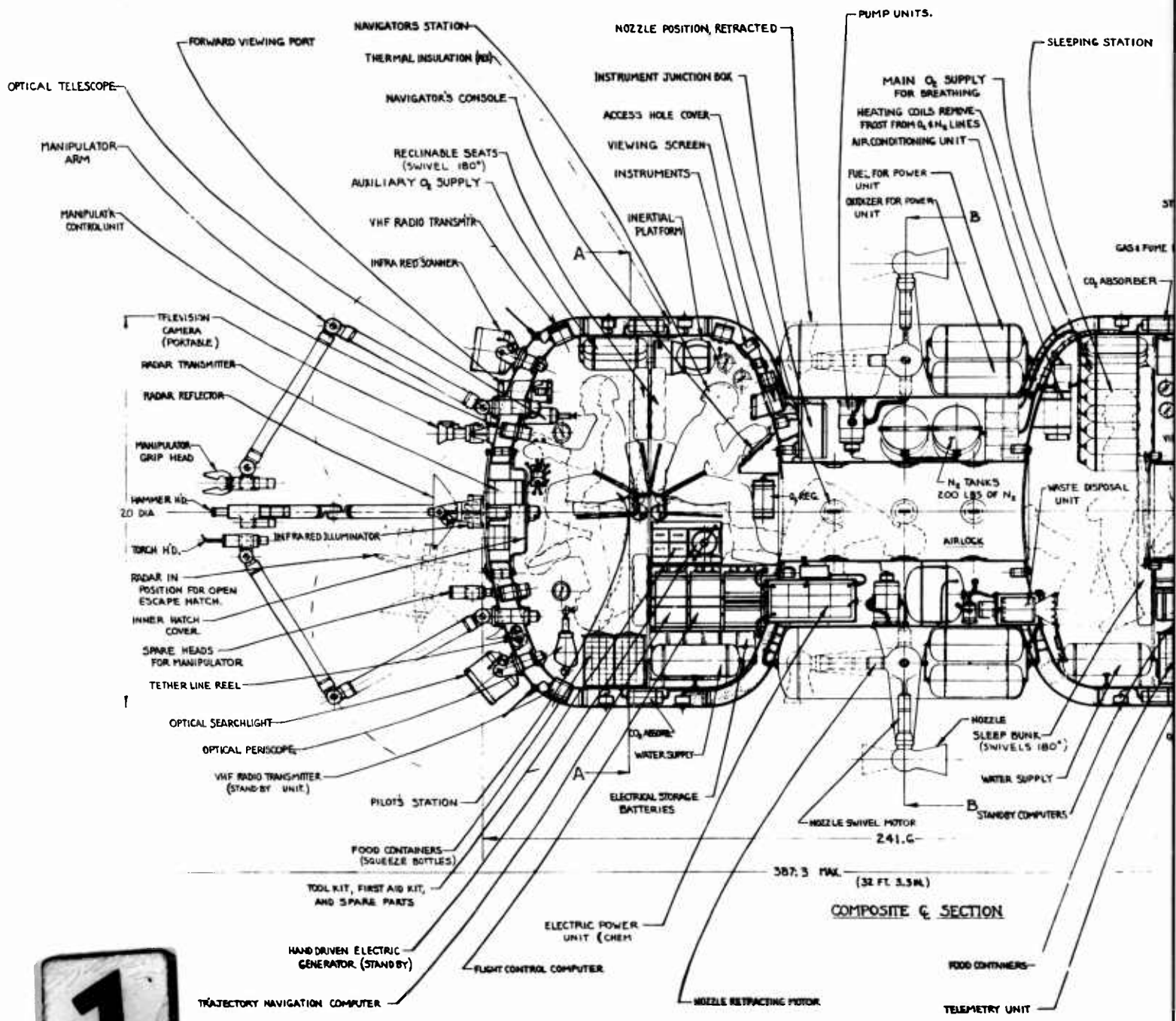

1

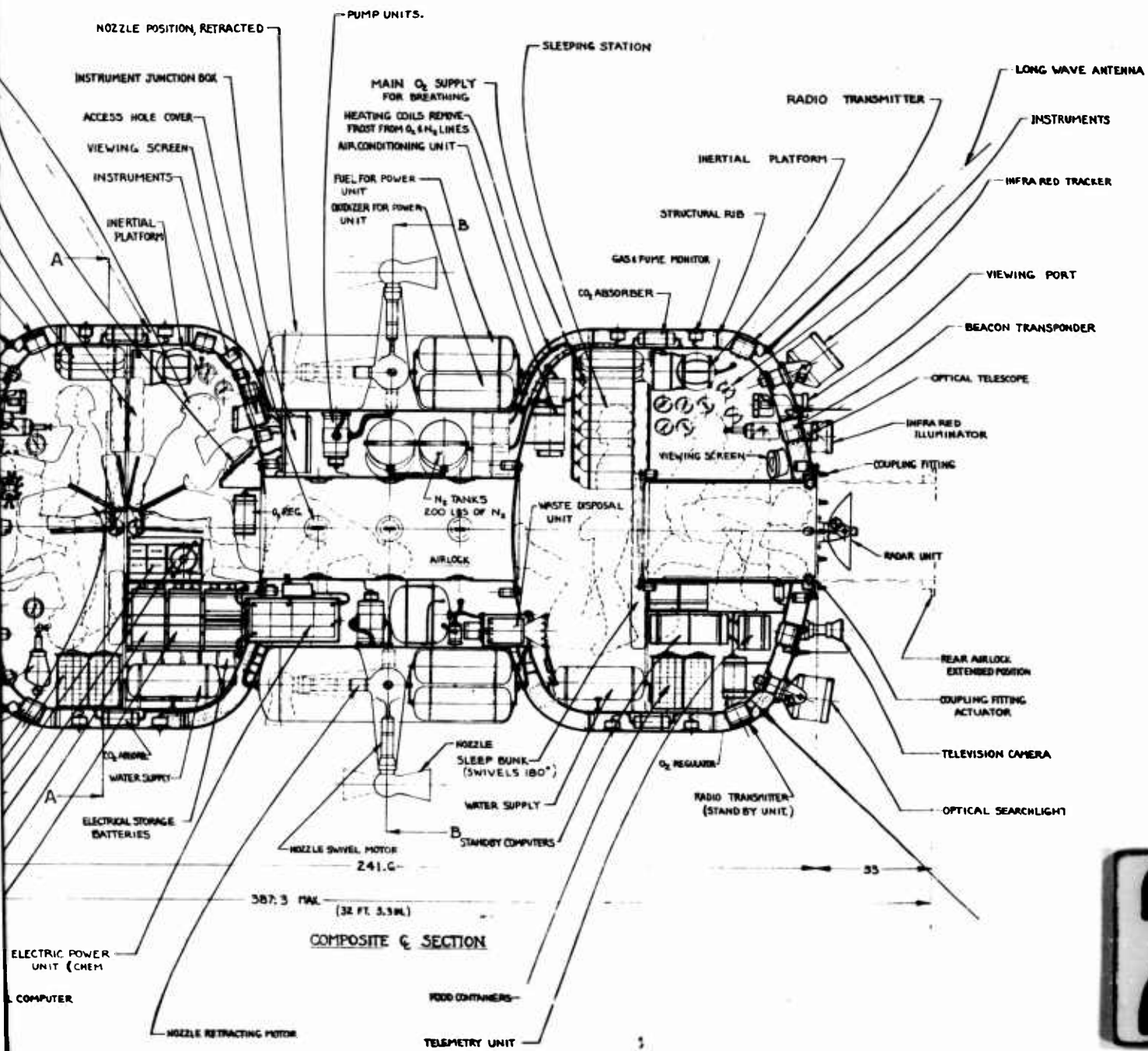

FIG. 3-17 ASTROTUG DETAIL 127

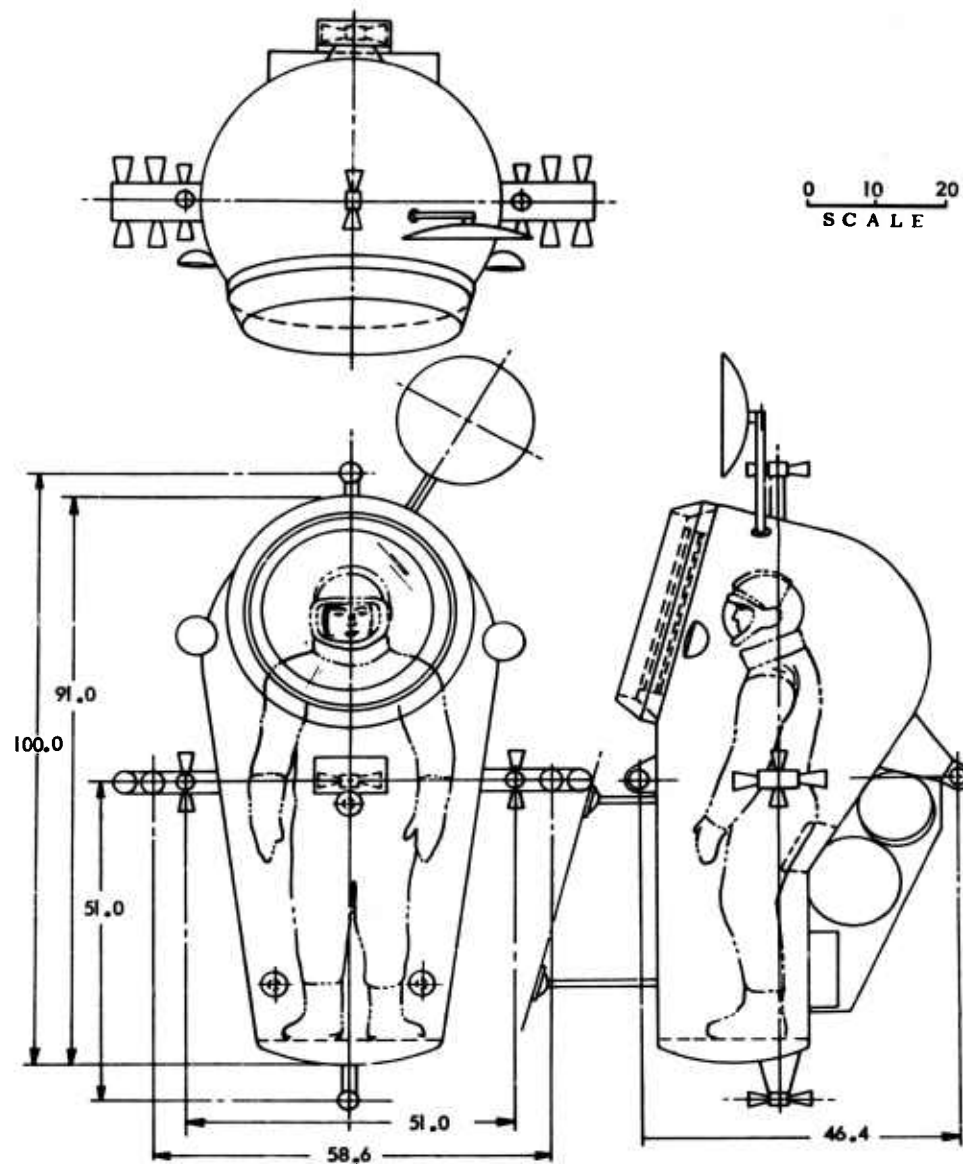
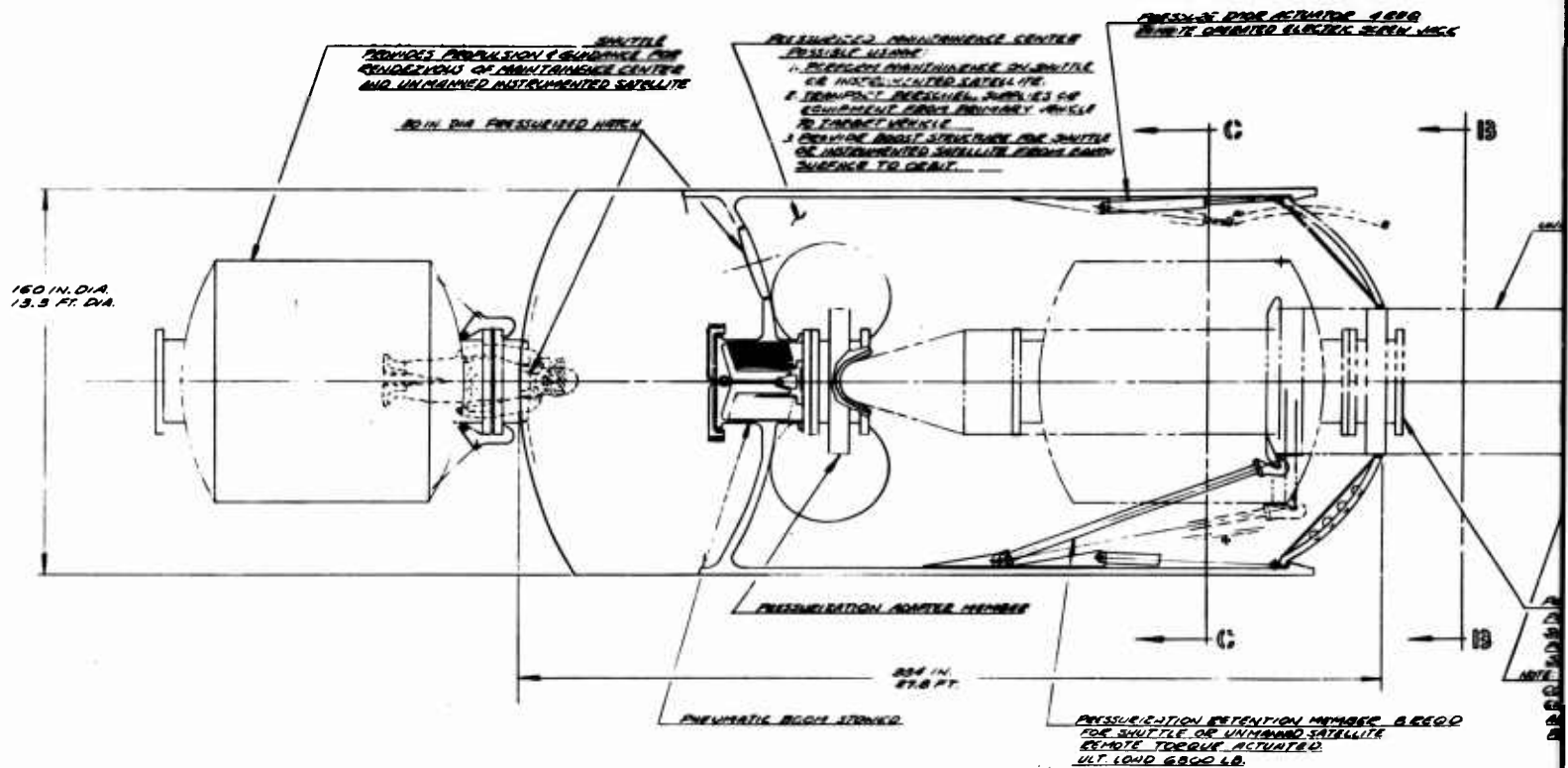

FIG. 3-18 MINIMUM SHUTTLE CONCEPT



1

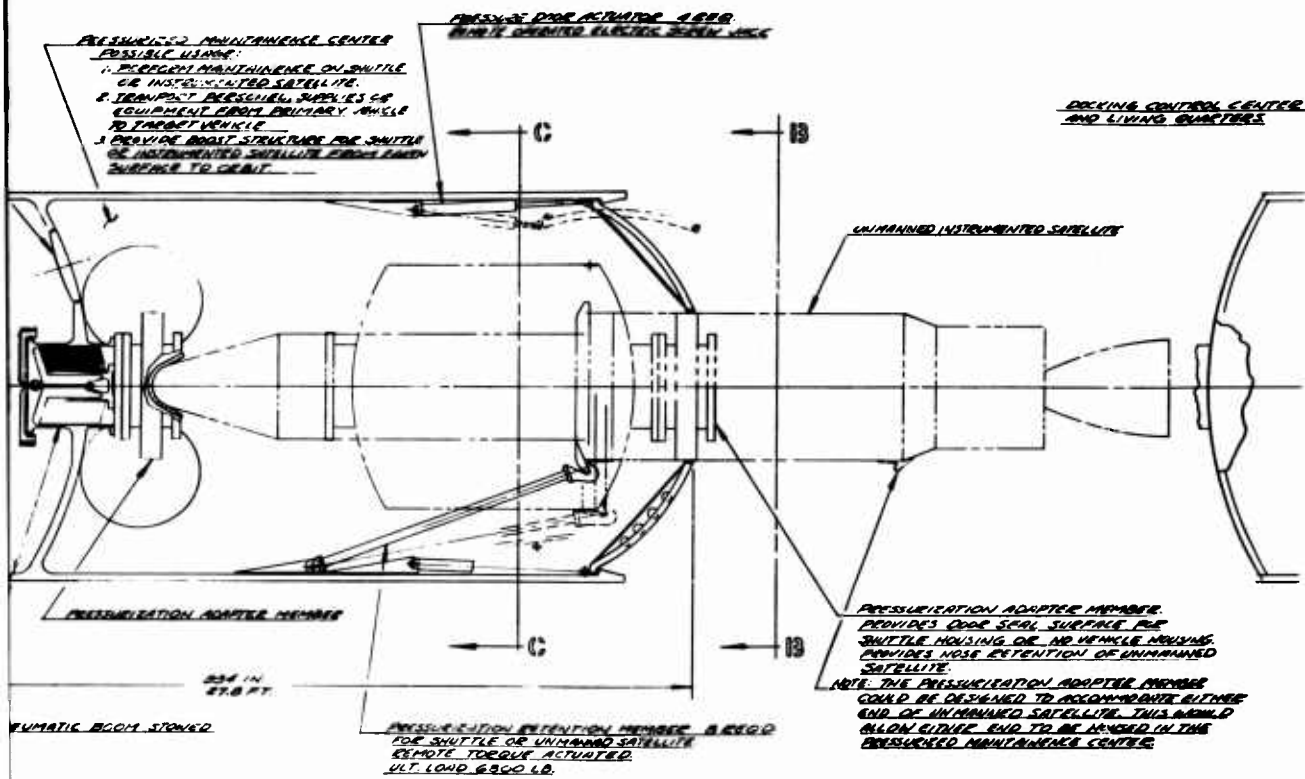

FIG. 3-20 MAINTENANCE CENTER OPERATION

2

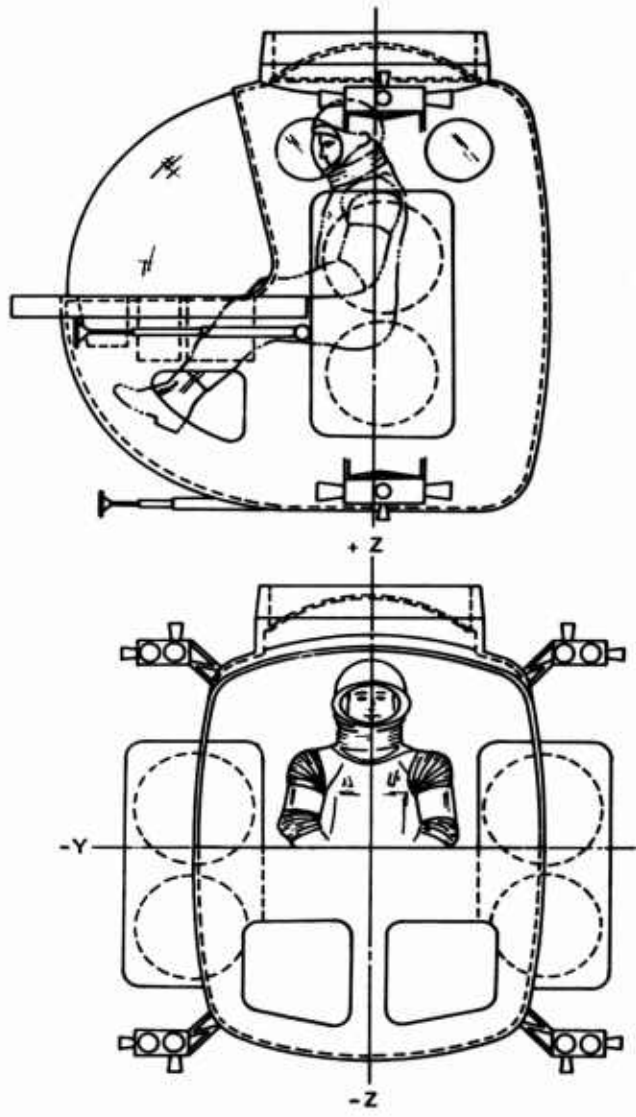

FIG. 3-21 MULTI-ENGINE SHUTTLE

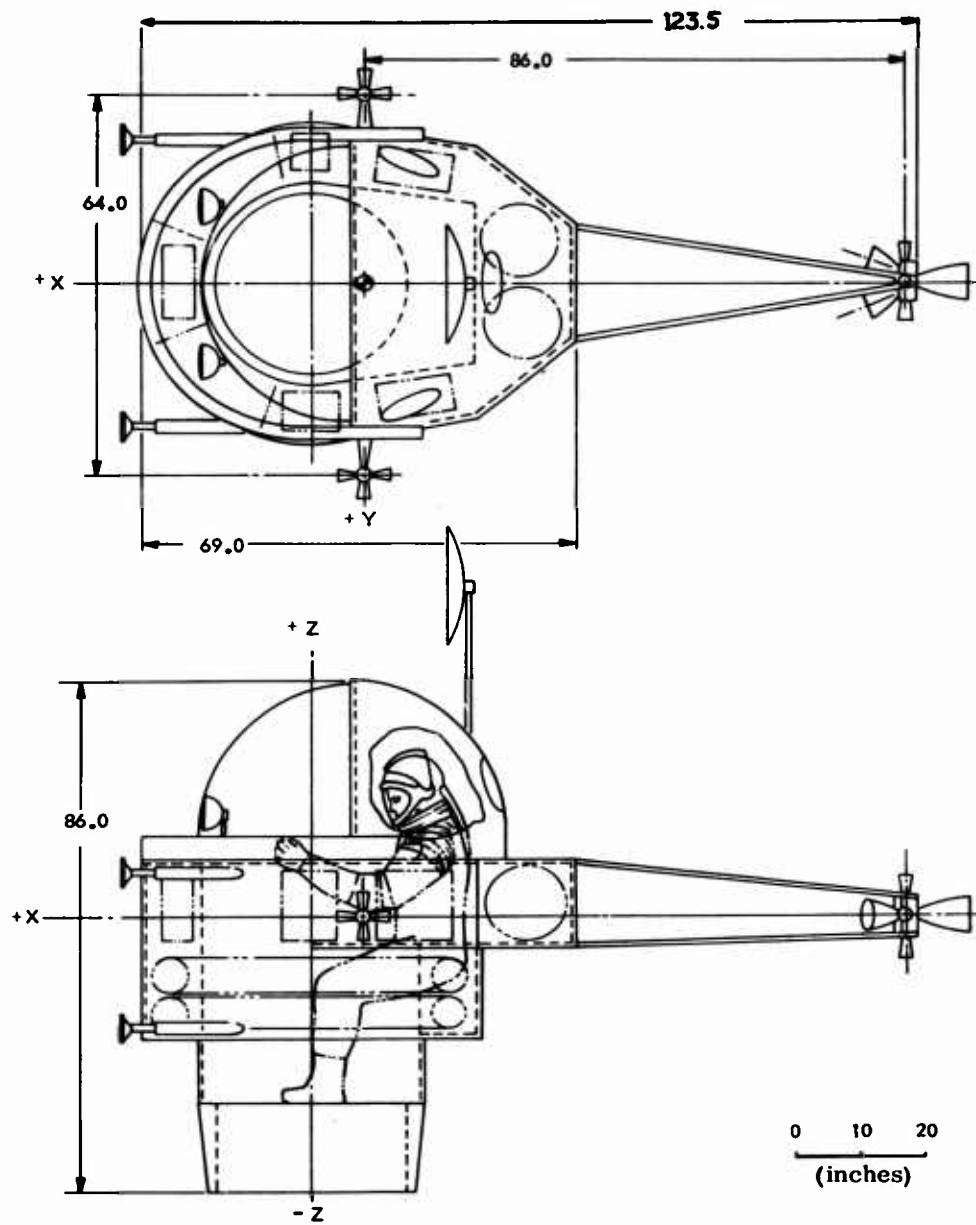

FIG. 3-22 BOOM SHUTTLE

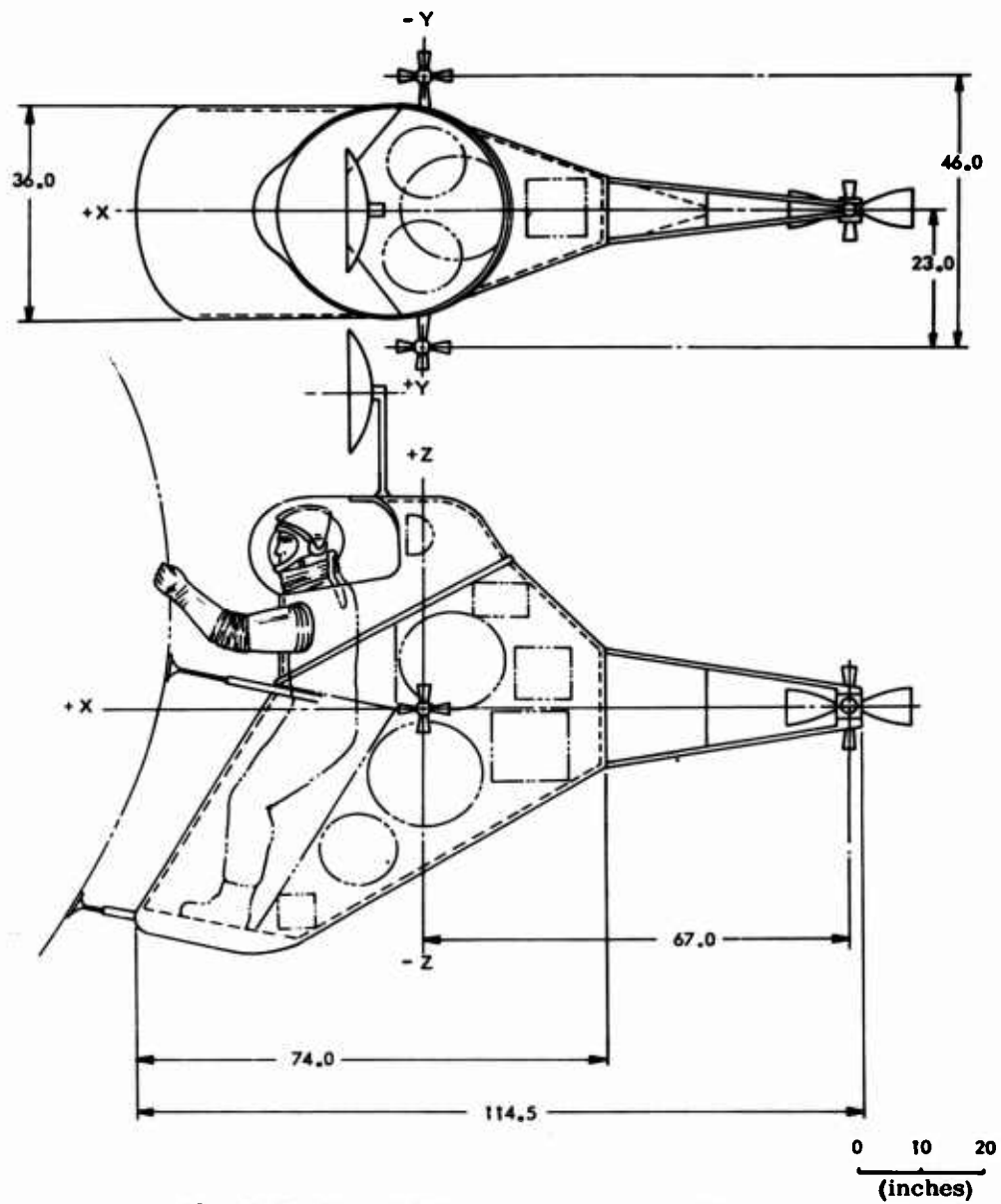

FIG. 3-23 BOOM SHUTTLE WITH SLEEVES

3.5 SHUTTLE SYSTEM EVALUATION

The selection of a configuration for preliminary design in the light of the mission analysis and conceptual studies of the preceding section is discussed in this section.

The conceptual studies of vehicles to satisfy the mission requirements demonstrated that the ideal shuttle for some missions is considerably different in equipment and capabilities than that for other missions. In particular, the space assembly and the 20,000-lb cargo missions require greater range and propellant capacity than the others. The question then arises as to whether these capabilities need be provided simultaneously or whether the phasing of the missions will suggest different shuttles for different time periods. In Table 2-2 the large space stations and deep space exploration programs which require such missions are the latest expected to be operational. It is apparent that those missions requiring the greatest capability in the shuttle are those of least urgency.

The selection of a technique for performing repair and maintenance operations is based on the experimental work summarized in Section 5.4. In this study typical tasks selected from Ref.3-2 were simulated by the use of wooden mock-ups. A subject in a Mark 4 pressure suit was timed as he performed each task unpressurized, pressurized in each of open-hatch arrangements, and finally with a simulated sleeve technique. As indicated by the test results, techniques which require the operator to be separated from his work by the wall of the vehicle and which impose access problems by restricting both reach and mobility introduce severe difficulties. As attempts are made to remove these difficulties by modifying the design of the sleeves or of the manipulators, the design approaches that of a worker in a space suit surrounded by a protective shell with no barriers between him and his work. Thus, although further improvement in the design of repair and maintenance equipment, in the satellites to be serviced, and in the subsystems will eventually lead to satisfactory techniques, this study concludes that the most practical immediate design for use with existing and currently planned satellites is the shelter concept.

The ultimate shuttle configuration recommended for the preliminary design study is illustrated in Fig. 1-5. The salient features are the shelter installation, the use of grapples for attaching the shuttle to the target which incorporate provisions for adjusting the relative positions as required by the worker, the docking hatch intended to permit ingress and egress without exposure to space, and the propulsion system which provides redundant nozzles for primary propulsion and which permits large variations in cg location for the convenient transport of cargo or personnel without obstructing the pilot's vision.

Having defined the configuration and recognizing: (1) that an experimental and training program represents the most urgent mission, and (2) that an extensive development program will inevitably take place before the more difficult missions are attempted, several system concepts were considered. The first was to simply modify Mercury or Gemini to suit the shuttle requirements. This proved unattractive due to the need for extensive re-design, and the basic structure is very heavy having been designed for reentry. It would be difficult to adapt the reentry shape to an efficient shuttle design. The second approach considered was to start immediately on the development of the ultimate configurations. However, this involves a high risk as it would be difficult to incorporate the results of experimental work expected to be done in the design period. The selected approach can be described as a planned growth program. The basic concept is to design a "chassis" which may accept a variety of "custom bodies" to suit the various experimental training programs and missions as they are developed.

This concept is developed in Section 6, Preliminary Design.

Section 4

ASTRODYNAMICS AND RENDEZVOUS TECHNIQUE

The astrodynamic and guidance data required for both the operational analysis and the preliminary design of the shuttle are developed in this section. The data is given in charts directly applicable to the shuttle mission. A major consideration in the design of the shuttle is the range for which the propulsion, life support, and guidance sensors are designed. The shuttle range is expected to be determined by the errors in matching the orbits of the primary and target vehicles. A study is therefore presented of the launch errors of an unmanned booster, followed by a study of the errors in Hohmann transfers resulting from errors in the initial conditions. The characteristic velocity required of the shuttle is next determined as a function of transfer time and range. Various relative starting positions of primary target are considered, including both in-plane and out-of-plane cases. As the relative position of two orbiting bodies is not constant, except for bodies in the same orbit, a study of the change in range with time is made considering various differences in orbital elements. Following this is a brief calculation of the ΔV 's necessary to maintain two bodies at a constant range is presented. Finally the need for sensors to supplement the pilot's vision is discussed and a guidance technique suitable for use with the shuttle is developed.

4.1 LAUNCH INJECTION ERRORS

4.1.1 Objective

In this section the expected accuracy of launching from earth to orbit is determined.

4.1.2 Analytical Model

The preferred method of determining the shuttle's maneuvering boundary is to postulate an earth-to-primary vehicle resupply mission. This analytical model provides for direct launch of the supply vehicle from Earth, and subsequent guidance into coincidence in velocity and position with the orbiting primary vehicle. The accuracy with which these orbits can be matched will determine the distance the shuttle must travel to transport the supplies between the supply vehicle and the primary.

With improving capabilities of injection guidance it is reasonable to assume for this model that the supply vehicle be unmanned and devoid of any homing or terminal guidance propulsion system of its own.

As a representative case, an Earth launch to rendezvous with a primary vehicle in circular orbit of 200 n.mi. was examined. The assumed booster is a typical Air Force vehicle.

For purposes of this model, depicted in Fig. 4-1, the following flight history of the supply vehicle is used. No restrictions are placed on the launch window for it is assumed that there is sufficient control and fuel to correct any orbital plane misalignment during ascent. Acceleration and attitude are inertially determined onboard the supply vehicle and used to adjust the actual flight path to coincide with a programmed path.

At burnout, the trajectory corresponds to the perigee of an elliptical orbit with an apogee of 200 s.mi.; the perigee altitude is 60 s.mi. After coasting 180 deg, the supply vehicle initiates an inertially controlled terminal maneuver to produce a condition of coincidence with the primary vehicle with zero relative velocity. It is assumed that the dispersion in position and velocity at rendezvous is determined by booster burnout and impulsive terminal thrust parameters. This dispersion will dictate the range requirements for shuttle operations.

From the specified flight profile, the orbital elements and the transfer point injection parameters are derived from orbital mechanics:

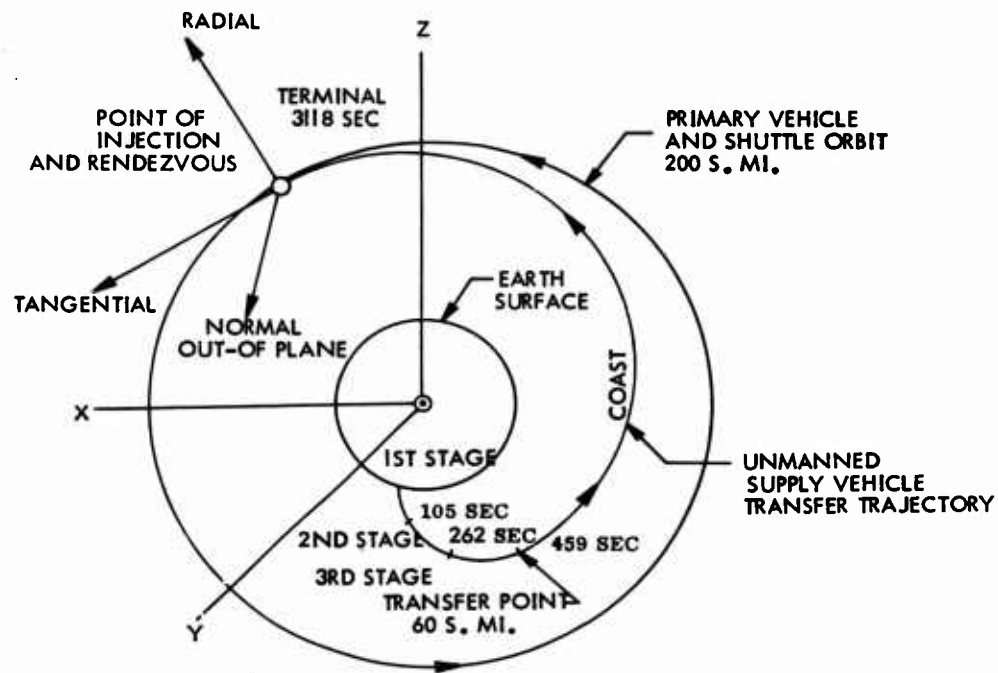

FIG. 4-1 TRAJECTORY RELATIONS BETWEEN THE UNMANNED SUPPLY VEHICLE AND THE PRIMARY VEHICLE

A_t semi-major axis of transfer orbit, 21.612×10^6 ft
 e_t eccentricity of transfer orbit, 0.01710
 V_p perigee velocity of transfer orbit, 25,983 fps
 V_a apogee velocity of transfer orbit, 25,089 fps
 V_c 200 s.mi. target orbit circular velocity, 25,306 fps
 ΔV° velocity increment at rendezvous 217 fps
 τ period of transfer orbit, 5318 sec.

The flight path angle will be zero at the apogee and perigee of the transfer orbit.

4.1.3 Sources of Error

This analysis assumes the error in placing a particle in a predetermined orbit is much greater than predicting the future position of an orbiting particle. Thus, the target ephemeris is assumed to be accurately known and programmed in the supply vehicle. Such an assumption is justified by comparing the position errors of the order of 1000 ft which result from this study, with the error in semi-major axis in the target orbit of 200 ft when such estimates are based on ground track data. Furthermore, it is assumed that no errors or time lags are incurred in computation and data processing. The significant sources of error are considered to be in:

V_B supply vehicles burnout velocity
 γ_B supply vehicles burnout flight path angle
 λ_B angle between supply vehicles velocity vector and target plane
 r_B burnout radius
 t_c coasting period
 ΔV° rendezvous velocity increment

From these sources of error, six errors will occur at the time of intended rendezvous. These errors, the objective of this study, are

ϵ_r error in rendezvous radius
 ϵ_θ rendezvous error in the orbit plane and normal to ϵ_r
 ϵ_y out-of-plane position error
 ϵ_v velocity magnitude error
 ϵ_γ error in flight path angle at rendezvous
 ϵ_λ out-of-plane velocity angle at rendezvous

For purposes of this analysis it is assumed that the first three errors result from propagation of transfer point errors. The latter three errors result from propagation of transfer point errors plus the errors incurred in the rendezvous maneuver.

4.1.3.1 Propagation of Departure Errors

Position errors at rendezvous will arise principally from transfer point errors. Given a set of transfer point conditions, the rendezvous radius will be:

$$r^{\circ} = \frac{a_t(1 - e_t^2)}{1 + e_t \cos \theta^{\circ}} \quad (20)$$

where

$$\theta^{\circ} = \frac{\Delta t}{a_t \sqrt{a_t/\mu}}$$

$$\frac{1}{a_t} = \frac{1}{r^*} - \frac{V_t^2}{\mu}$$

$$1 - e_t^2 = \frac{r^* (2a_t - r^*)}{a_t^2} \cos^2 \lambda^*$$

*Asterisk denotes errors at burnout.

The parameters originally in error (r^* , V^* , γ^*) propagate to the rendezvous point in a manner found by differentiating the equations for r and the parameters which determine it. Through this process it is observed that:

$$\epsilon_{a_t}^2 = \left[\frac{a_t}{r^*} \right]^2 \epsilon_{r^*}^2 + \left[2V^* a_t/\mu \right]^2 \epsilon_{V^*}^2 \quad (21)$$

$$\epsilon_{\theta^{\circ}}^2 = \left[\frac{\theta^{\circ}}{\Delta t} \right]^2 \epsilon_{\Delta t}^2 + \left[\frac{3\theta^{\circ}}{2a_t} \right]^2 \epsilon_{a_t}^2 \quad (22)$$

$$\epsilon_{e_t}^2 = \left[\frac{1 - e_t^2}{2e_t} \tan \gamma^* \right]^2 \epsilon_{\gamma^*}^2 + \left[\frac{(1 - e_t^2)(r^* - a_t)}{e_t a_t (2a_t - r^*)} \right]^2 \epsilon_{a_t}^2 \quad (23)$$

$$+ \left[\frac{(1 - e_t^2)(a_t - r^*)}{e_t r^* (2a_t - r^*)} \right]^2 \epsilon_{r^*}^2$$

$$\epsilon_{r^o}^2 = \left[\frac{r^o}{a_t} \right]^2 \epsilon_{a_t}^2 + \left[\frac{r^o e_t^2 \sin \theta^o}{1 + e_t \cos \theta^o} \right]^2 \epsilon_{\theta^o}^2 + (r^o)^2 \left[\frac{2e_t}{1 + e_t} + \frac{\cos \theta^o}{1 + e_t \cos \theta^o} \right]^2 \epsilon_{e_t}^2 \quad (24)$$

Since target orbit injection occurs a nominal 180 deg from the transfer point, out-of-plane errors at rendezvous will be the same as the errors at the perigee of the transfer ellipse. Consequently, the out-of-plane distance of the supply vehicle from the target orbit at the transfer point is equal to that distance at rendezvous.

4.1.3.2 Rendezvous Position Errors

In general the position errors at rendezvous will consist of the transfer point position errors propagated in their values at injection. The three components of rendezvous position error are thus:

$$\epsilon_{z^o}^2 = \epsilon_{r^o}^2 \quad \epsilon_{\gamma^*}^2 \quad (25)$$

$$\epsilon_{y^o}^2 = \epsilon_{y^*}^2 \quad (26)$$

$$\epsilon_{x^o}^2 = \left[r^o \epsilon_{\theta^*} \right]^2 + \left[r^* \epsilon_{\theta^*} \right]^2 \quad (27)$$

4.1.3.3 Inertial Instrument Errors

Estimation of specific error magnitudes require that information be obtained concerning the source errors; the errors in vehicle state at burnout.

The data used for this analysis are typical of the errors produced by a standard equipment complement for a launch vehicle.

The following error magnitudes were reported:

Accelerometer

Threshold Error	$20 \times 10^{-6} \text{ g}$
Scale Factor	$2 \times 10^{-6} \text{ g/g}$
Non-linearity	$2 \times 10^{-6} \text{ g/g}^2$

Gyro

Random Drift	0.03 deg/hr
Non-linearity	0.03 deg/hr - g
Anisoelasticity	
Input axis	$0.045 \text{ deg/hr} - \text{g}^2$
Spin axis	$0.075 \text{ deg/hr} - \text{g}^2$

No data were directly available on the contribution from control system sources. However, some results were available on the burnout errors expected for a 600-sec trajectory resulting in a circular orbit at 320,000 ft. The following 1σ errors were estimated from this error analysis and include both guidance system and control system contributions.

Velocity Error

Normal	3 fps
Longitudinal	2 fps
Radial	3.5 fps

Position Error

All axes	Approximately 800 ft
----------	----------------------

4.1.3.4 Use of Error Source Information

The trajectory for the flight profile in Fig. 4-1 involves a 459-sec ascent, and a terminal velocity (inertial) of 25,700 fps. Since the terminal velocity is approximately the same as the 600-sec ascent, from which the error data were taken, equal anisoelasticity and scale factor errors may be expected. Because

the ascent time is shorter, bias and drift errors will be smaller in the 459-sec trajectory and non-linear errors larger.

Because of these differences in the two trajectories, the errors of the rendezvous trajectory will not be the same as those of the circular orbit for which more data are known. Thus, it was decided to determine burnout errors from guidance equipment errors alone. Two problems arise in accomplishing this. First, the control system errors are not known. While control system errors such as a 1 fps thrust termination uncertainty may be assumed to be small compared to the influence of guidance equipment, this assumption must be checked before results based on it may be reliably employed. The second problem is that the alignment of the gyro package in inertial coordinates, is not known and hence the designations "spin" and "input" axis errors are not too useful. The significance of this problem, however, is minimized by the fact that the source errors in these two directions are not much different. For purposes of this analysis, it will be assumed that the source giving the larger error (the spin axis) is aligned with the orbital plane.

4.1.3.5 Gyro Error

Three components of gyro error exist: bias, anisoelasticity and non-linearity. The error in burnout parameters due to each of these sources will be considered in turn.

The drift error is reported as .03 deg/hr. The angular error at the end of the 459-sec ascent is thus 0.00383 deg.

The anisoelastic error is 0.03 deg/hr-g^2 . At the end of 459 secs, the angular error due to it will be:

$$\epsilon_{\alpha} = 0.03 \int_0^{459} a^2 dt \quad (28)$$

This function has been evaluated numerically by dividing the trajectory into about 80 increments. From this process, the non-linearity error is 0.0063 deg.

The non-linearity error is 0.045 deg/hr-g in a direction normal to the orbital plane and 0.075 deg/hr-g in the orbital plane. The angular burnout error produced by it will be:

$$\epsilon_{\alpha}' = k \int_0^{459} a \, dt \quad (29)$$

From a numerical analysis, the integral has a value of 0.2107 g-hr. This leads to angular errors of: normal, 0.0095 deg; in-plane, 0.0168 deg.

The total angular error will be the RSS of the three components. This gives an out-of-plane error of 0.01202 deg and an in-plane component of 0.0178 deg.

Gyro error will be manifest as contributions of both velocity and position error at burnout. The velocity error will be related to the burnout velocity:

$$\epsilon_v = V_B \sin \epsilon_{\alpha} \quad (30)$$

This leads to velocity errors of: out-of-plane, 5.11 ft/sec; in-plane component, 7.58 fps.

Gyro contribution to position errors may be shown to be related to the distance traveled by the vehicle to burnout:

$$\epsilon_p = (\sin \epsilon_{\alpha}) \int V \, dt = D \sin \epsilon_{\alpha} \quad (31)$$

From this, and the fact that the 459-sec trajectory involves a distance of 5,137,000 ft, we find the gyro induced position errors to be: normal, 1079 ft; radial, 1598 ft.

4.1.3.6 Accelerometer Error

Errors in the accelerometer contribute both position and velocity errors at burnout. As with the gyro, there are three contributions to this.

Bias error in velocity is found as:

$$\epsilon = 20 \times 10^{-6} \int dt = 0.295 \text{ ft/sec} \quad (32)$$

Scale factor error is:

$$\epsilon = 2 \times 10^{-6} \int a dt = 0.0486 \text{ ft/sec} \quad (33)$$

Non-linearity error is:

$$\epsilon = 2 \times 10^{-6} \int a^2 dt = 0.173 \text{ ft/sec} \quad (34)$$

The total accelerometer velocity error is the RSS of these three contributions: 0.324 fps.

The accelerometer's contribution to the position error is more difficult to estimate since it depends upon factors which vary in different directions. One factor common in all directions, however, is the bias error. It is estimated as:

$$\epsilon'_p = 20 \times 10^{-6} \int_0^{459} \left[\int_0^{459} dt \right] dt \quad (35)$$

and is found to be 68 ft.

Anisoelasticity contributes an error proportional to the burnout velocity in the direction being considered.

The nominal distances traveled are: in the normal direction, 0; in the radial direction, 364,520 ft; and tangentially, 5,136,000 ft. These result in errors of 0, 23, and 327 ft, respectively, in the burnout position.

The final accelerometer error contribution is that of non-linearity. The magnitude of this error source is found numerically as:

$$\epsilon_p'' = 2 \times 10^{-6} \left[\int \left(\int a^2 dt \right) dt \right] \quad (36)$$

The double integral in the three principal directions is: normal, zero; radial, 75,000 g²-sec², tangential, 452,000 g²-sec². The resulting position errors are: 0 ft, 4.8 ft and 29 ft, respectively.

4.1.4 Source Errors - Summary

The foregoing analysis may be summarized as tables of constituent and total errors in position and velocity.

VELOCITY ERROR

	<u>Gyro</u>	<u>Bias</u>	<u>Scale Factor</u>	<u>Non-Linearity</u>	<u>RSS (fps)</u>
Normal	5.11	0.295	0.049	0.173	5.13
Radial	7.85	0.295	0.049	0.173	7.85
Tangential	0.00	0.295	0.049	0.173	0.324

POSITION ERRORS

	<u>Gyro</u>	<u>Bias</u>	<u>Scale Factor</u>	<u>Non-Linearity</u>	<u>RSS (ft)</u>
Normal	1079	68	0	0	1080
Radial	1598	68	23	5	1600
Tangential	0	68	327	29	335

As a check on the foregoing method, the influence of the same component errors on a hypothetical 600-sec ascent was estimated. This led to gyro velocity errors of 4.81 fps (tangential) and 3.48 fps (normal). This compares favorably with 3.0 and 2.0 fps for the known error analysis of a 600-sec ascent. The difference is likely due to incomplete knowledge of the orientation of the gyro package in the vehicle at launch.

The tangential errors for both velocity and position must be regarded as unreasonably small. Guidance component errors this small would doubtless be masked by control system errors. It is known that the gyro and accelerometer packages are so oriented as to minimize error. Because errors add in a RSS manner, this orientation cannot influence the RMS error in all three directions, but only effects a change in the distribution of the individual errors. To minimize the influence of control system errors, the three components of guidance equipment error should be made mutually equal. If this is done, we get a velocity error of 5.40 fps in each direction and a burnout position error of 1130 ft (1 - σ values).

4.1.5 Rendezvous Error

From previous work, the input errors and equations which relate input errors to rendezvous were given. The first step in estimating the propagated departure errors is to estimate errors in e_t and a_t .

$$\epsilon_{a_t}^2 = \left(\frac{a_t}{r^*} \right)^2 \epsilon_{r^*}^2 + \left(2V^* a_t^2 / \mu \right)^2 \epsilon_{V_t}^2 \quad (37)$$

Substituting into this, the radial position error (1130 ft) and the tangential velocity error (5.4 fps) previously determined, an error in a_t of 4655 ft is derived. In a similar manner, the error in transfer orbit eccentricity is shown to be $.0208 \times 10^{-3}$

The error in rendezvous true anomaly is found from:

$$\epsilon_{\theta^o}^2 = \theta_t^{o2} \left[\frac{\epsilon_{\Delta t}}{\Delta t} \right]^2 + \left[\frac{3}{2} \theta_t^o \right]^2 \left[\frac{\epsilon_{a_t}}{a_t} \right]^2 \quad (38)$$

Using $\epsilon_{\Delta t} / \Delta t = 10^{-8}$, $\theta_t^o = \pi$ radians and previously developed values of ϵ_{a_t} and a_t it is found that the contribution of time measurement error is only 0.03×10^{-3} milliradian and may be neglected. The a_t contribution to the error gives:

$$\epsilon_{\theta^{\circ}} = 1.015 \text{ milliradians}$$

Multiplying this angular error by the radius at rendezvous gives the tangential component of rendezvous miss distance: 22,312 ft.

To estimate the radial component of position error:

$$\epsilon_{r^{\circ}}^2 = \left(\frac{r^{\circ}}{a_t}\right)^2 \epsilon_{a_t}^2 + \left(\frac{r^{\circ} e_t \sin \theta_t^{\circ}}{1 + e_t \cos \theta_t^{\circ}}\right) \epsilon_{\theta^{\circ}}^2 + \left[r^{\circ} \left(\frac{2 e_t}{1 - e_t^2} + \frac{\cos \theta_t^{\circ}}{1 + e_t \cos \theta_t^{\circ}}\right)\right]^2 \epsilon_{e_t}^2 \quad (39)$$

Note that the second term goes to zero with $\sin \theta_t^{\circ}$ deg as θ_t° deg is π . Evaluating the remaining terms, we find that a_t contributes 4735 ft of error; e_t contributes 465 ft. The RSS error in the radial direction is 4850 ft.

From earlier discussions, the normal components of both position and velocity error at rendezvous are equal to those values at the transfer point. Thus, the normal component of rendezvous position is 1130 ft.

The rendezvous position errors are summarized in the following table of 1- σ error magnitudes:

<u>Error Component</u>	<u>1-σ Value (ft)</u>
Normal	1,130
Radial	4,850
Tangential	22,312

The miss distance probability is plotted on Fig. 4-2.

4.1.5.1 Velocity Error

Because it is of interest to know how the miss distance changes with time after the rendezvous, the post-rendezvous velocity error must be known. Since the rendezvous maneuver involves a thrust nominally in the tangential direction, errors in this impulse will only influence the error in the tangential component of velocity. Normal and radial velocity errors after rendezvous will be the same as they were at departure: 5.4 fps.

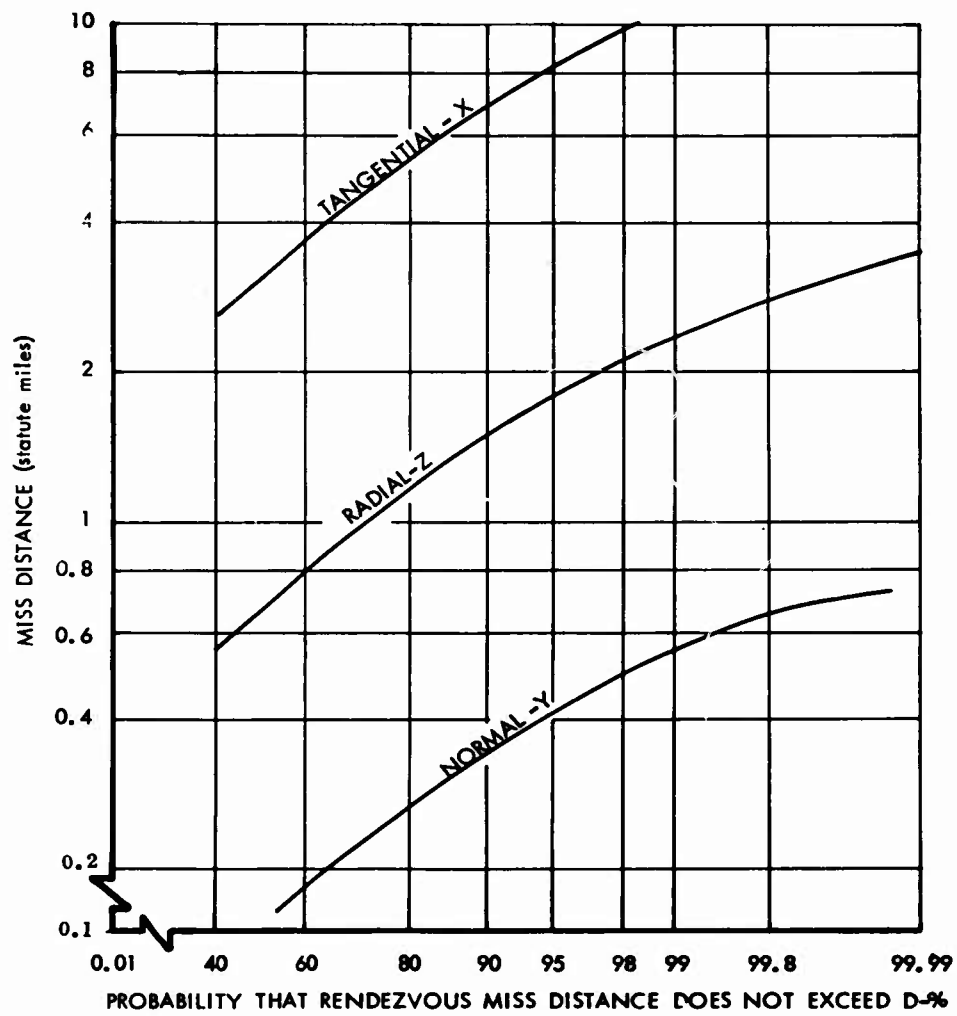

FIG. 4-2 RENDEZVOUS MISS DISTANCE PROBABILITY

Control system errors will predominate in application of the rendezvous impulse and a 1 percent error in ΔV at rendezvous may be expected. Since ΔV is 217 fps, the error in it will be 2.2 fps. Taking the RSS of this and the original 5.4 fps error, a post-rendezvous velocity error in the tangential direction of 5.7 fps is obtained.

4.1.5.2 Change in Miss Distance with Time

From the preceding analysis we find that the rendezvous errors in position and velocity are normally distributed, and the standard deviations of these distributions are known. Since the position of the ascending vehicle after rendezvous is not known until after rendezvous, it must be assumed that the shuttle does not leave the space station until this time. Because the shuttle will take a finite period to reach the transfer vehicle, the greatest interest is in the error in the supply vehicle's position when the shuttle reaches it, rather than immediately after the rendezvous impulse occurs. Hence, it is of interest to know how the rendezvous errors propagate with time.

If it were not for the influence of the Earth, the problem would be simply solved. The error in a particular direction would be the RSS of the initial error and the product of initial velocity error with time after rendezvous. This, however, gives a constantly increasing error which is at variance with the periodic nature imposed by the presence of the central body. Consider, for example, the out-of-plane component error. This may be related to the misalignment of the orbits. Any error present at rendezvous will be repeated every π radians, and will not increase indefinitely. It may also be expected that a statistical distribution of initial errors will exhibit a similar periodic behavior.

While a rigorous analysis of this statistical problem is possible, it involves more effort than the present need justifies. Essential to satisfy the needs of the present problem is a relationship between the RSS position error and time during the first hour after rendezvous. The period of the radial and normal components of error are nominally equal to that of the target orbit, about 1.5 hours. The period of the tangential error is very long when compared to an hour;

of the order of several hundred days. It is evident that while the one hour period of interest is long compared to periods of the normal and radial velocity components, it is very small compared to the period of the tangential error. As a result, the assumption of linearly increasing tangential error may be safely invoked for the tangential component, while it is invalid for the other two.

Notice now that of the three errors, the tangential substantially predominates; it has an initial 1- σ value of 4.2 mi while the others have similar values of 0.9 and 0.2 mi. As a result, any error in these latter two values, when RSS'ed with the tangential error will not be large although the radial error also affects range propagation (para. 4.4.2). A useful estimate of the standard deviation at time t is thus found by:

1. Assuming the tangential error at t to be

$$\epsilon_{pt}^2 = \epsilon_{po}^2 + (\epsilon_v t)^2 \quad (40)$$

2. Estimating the radial and normal error components graphically on the assumption that the time component begins to increase at a linear rate equal to the initial velocity error and is periodic.
3. Taking the total error as the RSS of these three components.

When the foregoing is accomplished, the graph of Fig. 4-3 results.

From Fig. 4-3 it appears that the 1/2-hour value of standard deviation is 4.7 n. mi; and the one hour value is 5.5 n. mi.

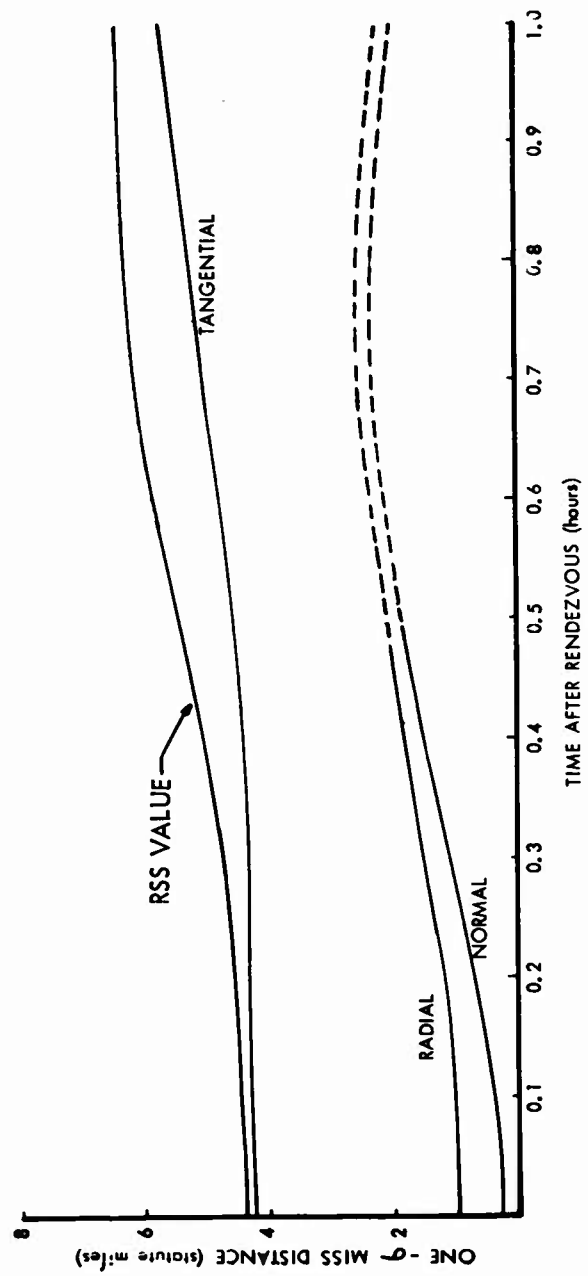

FIG. 4-3 CHANGE IN MISS DISTANCE WITH TIME

4.2 THE EFFECT OF HOHMANN TRANSFER ERRORS ON CLOSEST APPROACH TO A TARGET

The purpose of this parametric study is to determine the target volume of uncertainty which results from errors in position and velocity at the beginning of a Hohmann transfer. The linearized equations of motion were programmed for the analog computer. A rotating target-centered coordinate system as shown in Fig. 4-4 was used. The target, primary, and rendezvous orbits with respect to the inertial, geocentric system are illustrated in Fig. 4-5. Results are presented which show the effects of initial position errors on the relative position of the target and interceptor vehicles at the point of closest approach and at the apogee of the transfer ellipse. The particular results presented are for rendezvous at a 300 n.mi. altitude target orbit from a 100 n.mi. altitude primary orbit. Other cases were investigated, but this example is presented as representative for near earth orbits. The miss distances which result from the injection errors are based on a coasting trajectory after the initial impulse.

Errors in the x component of initial position alone cause equal errors in the x direction at the apogee of the transfer ellipse. The resulting miss distances are very small although at closest approach there will be an angle between the velocity vectors of the two vehicles. When investigating the initial error in y, it is necessary to use the circular satellite velocity corresponding to the actual altitude. The miss distance due to initial y-error is shown in Fig. 4-6. The errors in initial velocity increment, as shown in Fig. 4-7, cause large miss distances when the impulse is too small and smaller misses when the impulse is too large.

When considering the interaction of x and y errors, the initial position was varied around a circle with center at the exact position required for a Hohmann transfer. The position of closest approach due to these errors is shown in Fig. 4-8 and the position at the estimated time for rendezvous is shown in Fig. 4-9.

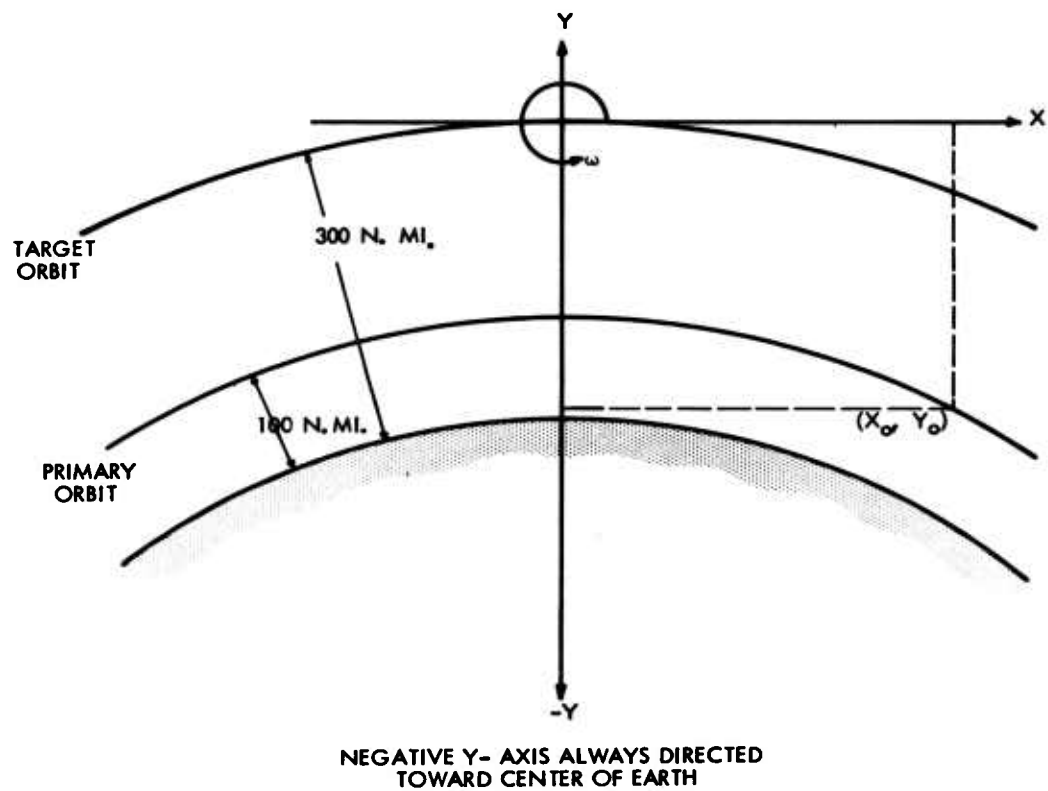

FIG. 4-4 DEFINITION OF TARGET-CENTERED ROTATING COORDINATE SYSTEM

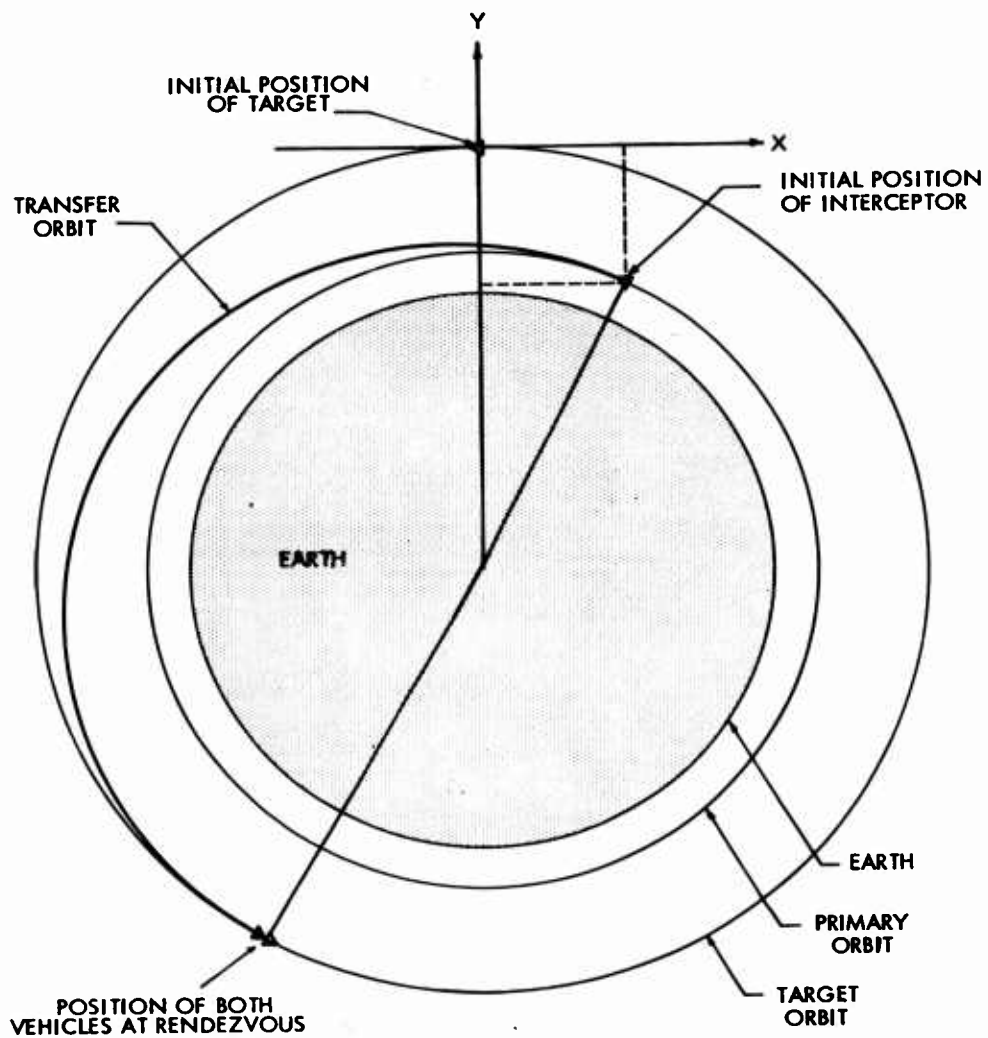

FIG. 4-5 ORBITS IN INERTIAL GEOCENTRIC COORDINATES

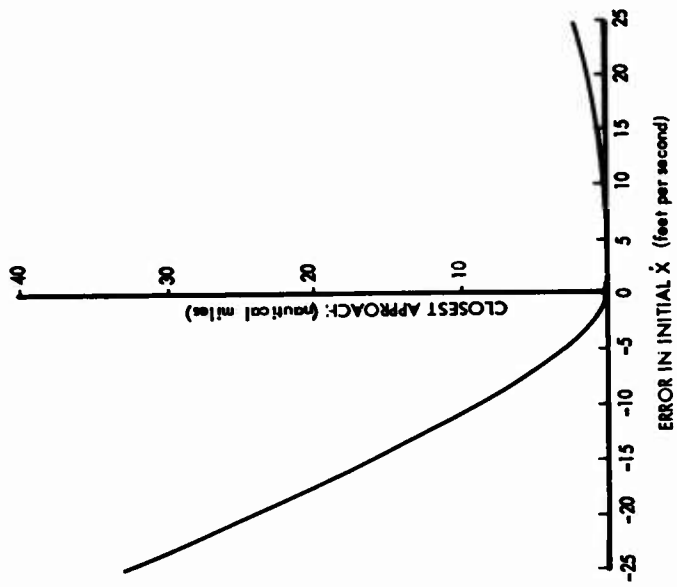

FIG. 4-7 CLOSEST APPROACH TO TARGET AS A FUNCTION OF ERROR IN INITIAL \dot{x}

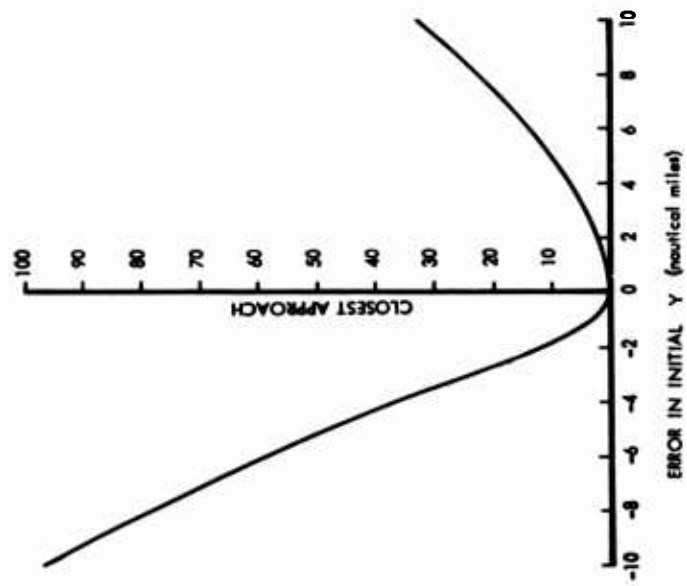

FIG. 4-6 CLOSEST APPROACH TO TARGET AS A FUNCTION OF ERROR IN INITIAL \dot{y}

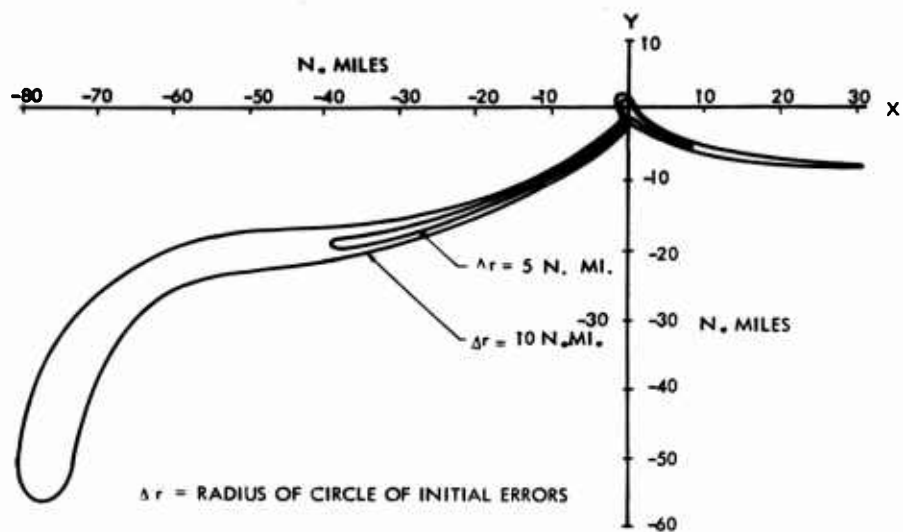

FIG. 4-8 POSITION OF CLOSEST APPROACH

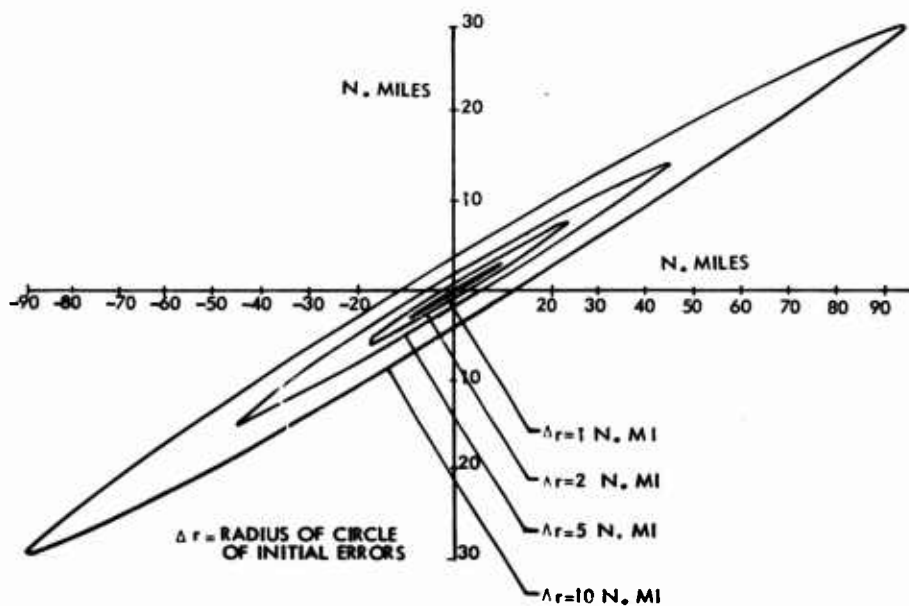

FIG. 4-9 POSITION OF INTERCEPTOR WITH RESPECT TO TARGET VEHICLE AT ESTIMATED TIME OF RENDEZVOUS

4.3 RENDEZVOUS CHARACTERISTIC VELOCITY AND TRANSFER TIMES

4.3.1 Introduction

The purpose of this study is to define the parameters necessary to establish design criteria for the rendezvous vehicle. The maximum initial separation of the rendezvous and target vehicles to be considered here is 20 n.mi. The results of the study are interpreted from three different aspects and presented in graphical form to enable an optimization in the design of vehicle propulsion and guidance systems. In-plane and out-of-plane transfers are considered.

4.3.2 In-Plane Transfers

4.3.2.1 Analytical Model. The problem under consideration is the two impulse, in-plane transfer between two vehicles in initially circular orbits. It should be noted that in some cases multi-impulse or continuous thrust propulsion may offer the advantage of simplicity of guidance with little propulsion penalty. In the two impulse cases, the first impulsive rocket firing injects the vehicle into the transfer orbit which intersects the target vehicle orbit at the time of arrival of the target vehicle. When the two vehicles rendezvous, the second impulsive firing reduces the relative velocity between them to zero. The characteristic velocity is defined as the sum of the changes in velocity imparted to the vehicle by the impulsive thrusts. The circular orbits of the target and interceptor vehicles and the elliptical transfer orbit are illustrated in Fig. 4-10. The paths of the two vehicles during the rendezvous maneuver are described by the heavy lines. For this study, a rotating, target-centered coordinate system, as discussed in the previous section is to be used. The negative x-axis is always in the direction of motion of the target vehicle and the negative y-axis is always directed toward the center of the earth; consequently, the axes will rotate with a constant angular rate equal to that of the target vehicle in its orbit about the earth. A target vehicle altitude of 300 n.mi. is chosen as a representative case for near earth orbits since there is small variation in the period and circular velocity for all orbits in this category. The position of the rendezvous vehicle with respect to the target is specified by R ,

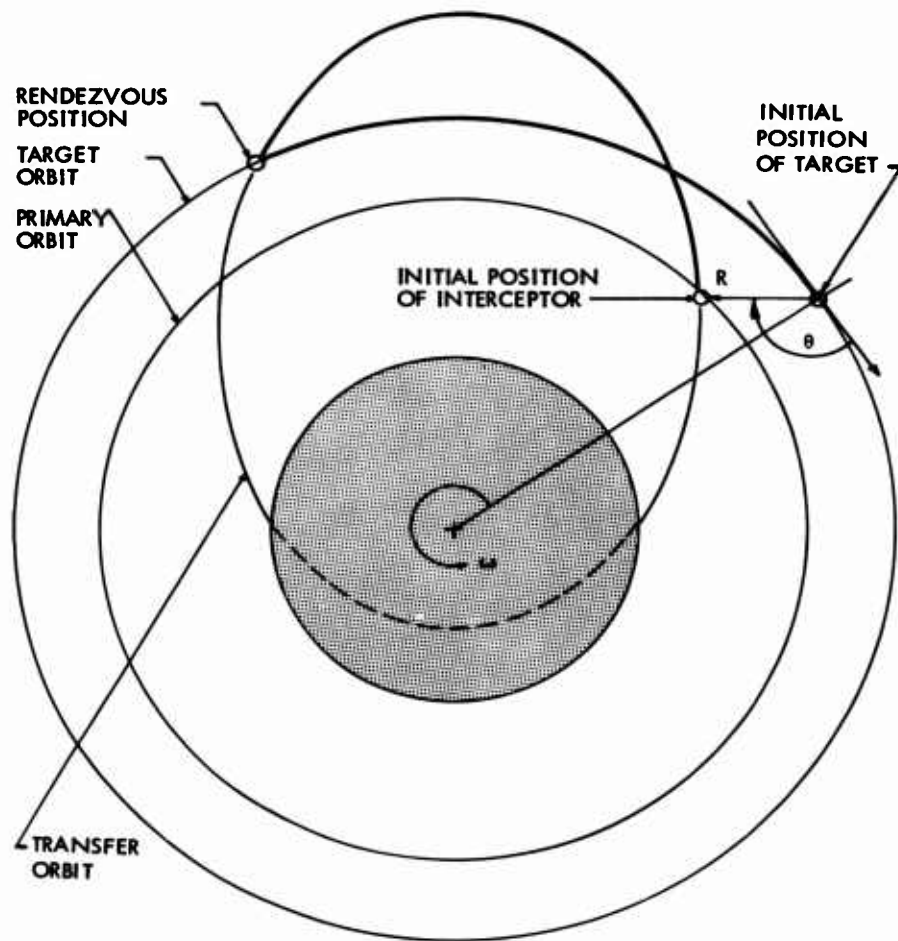

FIG. 4-10 ORBITS IN AN INERTIAL GEOCENTRIC COORDINATE SYSTEM

the range, or linear distance between the two vehicles, and an angle θ measured clockwise from the positive x-axis to the interceptor. Although the full non-linear equations of motion of the two vehicles could be used, for the close rendezvous considered here the equations can be linearized to produce the simpler set of equations:

$$\ddot{x} - 2\omega\dot{y} = 0 \quad (41)$$

$$\ddot{y} + 2\omega\dot{x} - 3\omega^2y = 0 \quad (42)$$

In the conventional form of notation ω is the angular rate of rotation of the axes and the dot over a variable denotes differentiation of that variable with respect to time. These equations yield closed-form solutions for the motion of the interceptor relative to the target. The problem was programmed for the IBM 7090 digital computer. The information generated in the solution of the problem is presented in the form of trajectories, characteristic velocity curves, and regions of rendezvous acceptability.

4.3.2.2 The Rendezvous Trajectory. When the initial position of the interceptor relative to the target and the total time for the rendezvous maneuver are given, the unique transfer trajectory is determined. To provide values for the initial position, the range is varied from 500 feet to 20 n. mi. For each value of the range, the angle θ is varied from 0 deg to 360 deg. The trajectories to rendezvous from each of these points are computed for values of time between 60 sec and 4000 sec. The results for an initial range of 20 n. mi. are presented in Figs. 4-11 and 4-12 as time history plots of the position of the interceptor with respect to the target at intervals of 5 percent of the total maneuver time. Due to the relatively small distances involved, the set of trajectories from initial points around a circle are symmetric about the origin.

4.3.2.3 Characteristic Velocity Requirements. When the initial position and total time are specified, the required characteristic velocity is determined. The curves in Fig. 4-13 show the variation of characteristic velocity with time to rendezvous from a given initial position. In preparing the figure, the initial

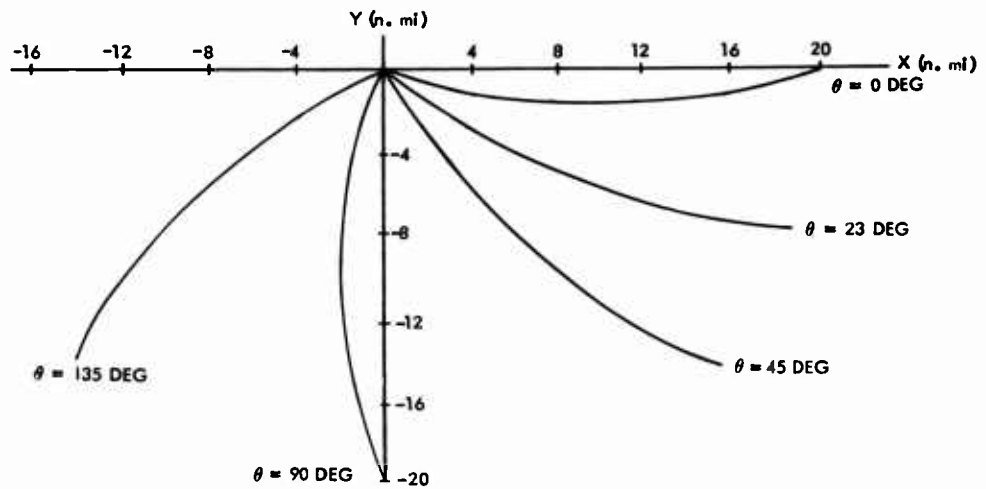

FIG. 4-11 TRAJECTORIES TO RENDEZVOUS FROM 20 MILES
IN 300 SECONDS

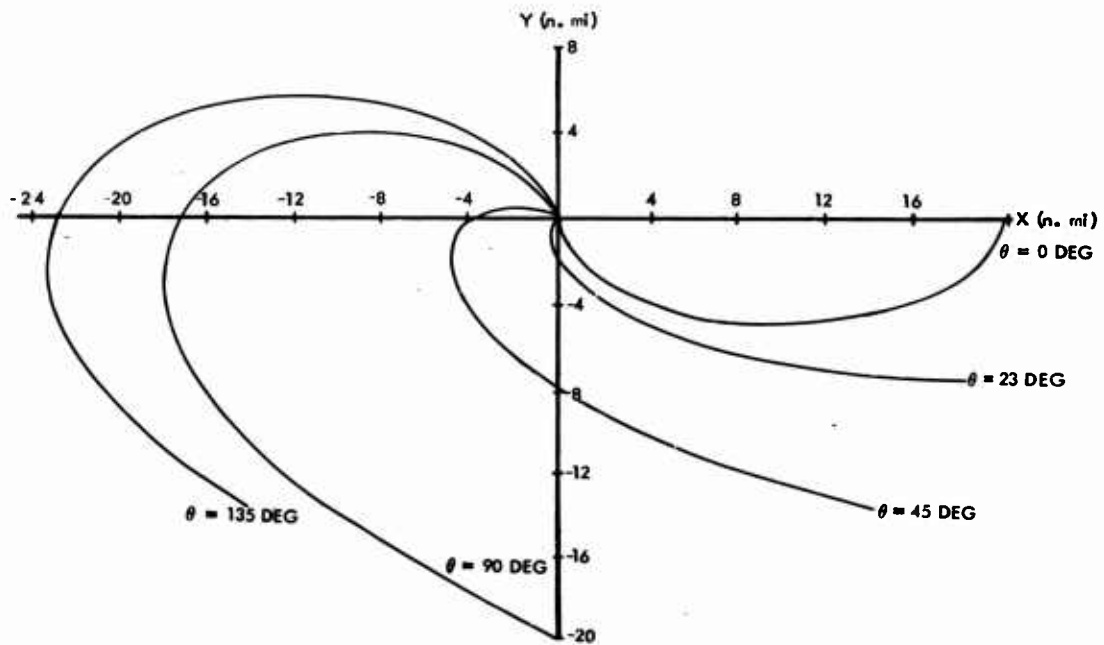

FIG. 4-12 TRAJECTORIES TO RENDEZVOUS FROM 20 MILES
IN 2500 SECONDS

range was fixed at 20 n. mi. and the curves were plotted for several values of θ . Due to the symmetry of the system, the results are presented for values of θ between 0 deg and 180 deg. It should be noted that for short periods of time, the required characteristic velocity varies inversely with total time to rendezvous. The value of time corresponding to the lowest point on each curve is the optimum time for the rendezvous maneuver requiring the least expenditure of fuel. Over the relatively small distances considered here, for a specific angle and total time, the characteristic velocity increases linearly with initial range.

Fig. 4-14 shows this for $\theta = 135$ deg and values for the total rendezvous time of 60, 200, 400, 1600, 2400 and 4000 sec. In Fig. 4-15, the time was fixed at 1600 sec and the characteristic velocity versus range was plotted for values of θ between 0 deg and 180 deg in increments of 10 deg. Data for a time of 600 sec is shown in Fig. 4-16.

4.3.2.4 Rendezvous Acceptability Regions. It can be seen from Fig. 4-13 that for values of time greater than 1600 seconds, the curves tend to level off and there is little change in required characteristic velocity due to increasing time. This value of 1600 seconds for total rendezvous time was used in the third part of the presentation as a practical time from the consideration of characteristic velocity, range and the variation of line-of-sight angle along the trajectory. In this portion of the study, the regions of rendezvous acceptability were developed as functions of the required characteristic velocity. The rendezvous acceptability region is the locus of points in the rotating coordinate plane from which it is possible to rendezvous in a given time with a given characteristic velocity. It is primarily a problem of determining the maximum possible initial range as a function of θ when the limits of time and characteristic velocity are pre-assigned. Fig. 4-17 is a plot of several of these contours of rendezvous acceptability for the given time of 1600 sec and total characteristic velocity values of 20, 40, 60, 80 and 100 ft per sec. The maximum possible ranges correspond to angles of approximately 25 deg and 205 deg which is in reasonable agreement with the theory since these are the required initial positions for a Hohmann transfer, the optimum rendezvous maneuver.

4.3.2.5 Summary - In-Plane Transfers. The linearized equations of motion in the relative coordinate system have been analyzed in previous work and have been found to yield results which are valid for the small distances considered here. Within the framework of these linearized equations, several conclusions can be drawn: (1) the required characteristic velocity is linear with initial range for the small distances considered, (2) for short time rendezvous, the required characteristic velocity varies inversely with total maneuver time, (3) as total time increases, the curvature of a trajectory becomes more pronounced, and (4) when a specific mission for the rendezvous vehicle is given, a comparison of the information presented here should be of use in determining a tradeoff in the design of the propulsion and the guidance systems.

4.3.3 Characteristic Velocity Requirements for Short-Time Out-of-Plane Rendezvous

The purpose of this discussion is to expand the solutions of the short-time rendezvous problem to the out-of-plane case. The analytical model used here is illustrated in Fig. 4-18. Two space vehicles are moving in phase in circular orbits at an altitude of 300 n. mi. The maximum separation distance between the vehicles is assumed to be 20 n. mi. Therefore, the angle between the orbit planes will be less than twenty seconds. The angle ψ is the central angle through which the vehicles have moved since they passed the point of intersection of the orbits. At any time the distance between the vehicles is a function of ψ . Fig. 4-19 presents the required characteristic velocity as a function of time to rendezvous. Curves are plotted for values of ψ of 30 deg, 45 deg, and 90 deg. The broken line in the figure represents the characteristic velocity required for a single impulse change of plane at the node. The opportunity for this optimum maneuver occurs twice each period.

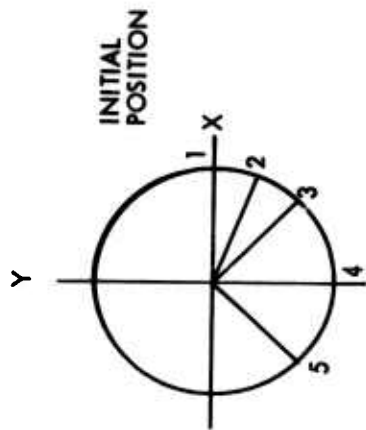

RANGE = 20 N. MI

	deg
1	0
2	23
3	45
4	90
5	135

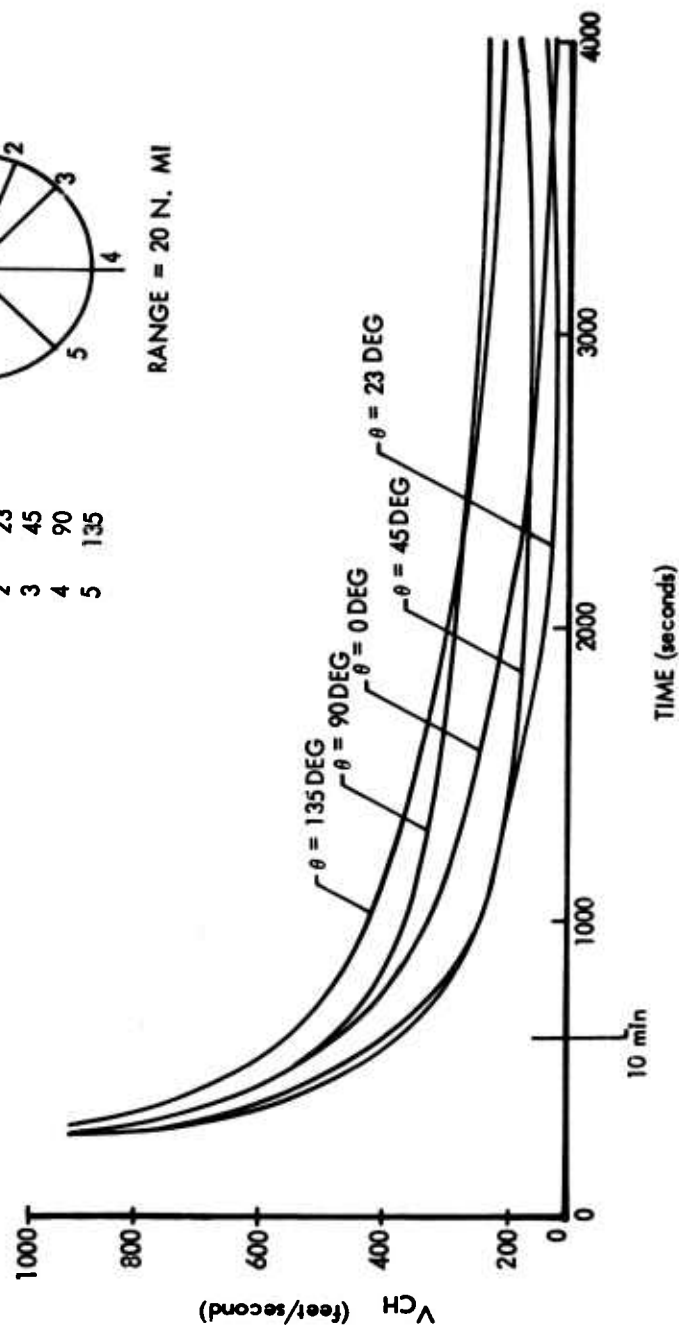

FIG. 4-13 CHARACTERISTIC VELOCITY VERSUS TOTAL TIME FOR RENDEZVOUS TRANSFER FROM A RANGE OF 20 NAUTICAL MILES

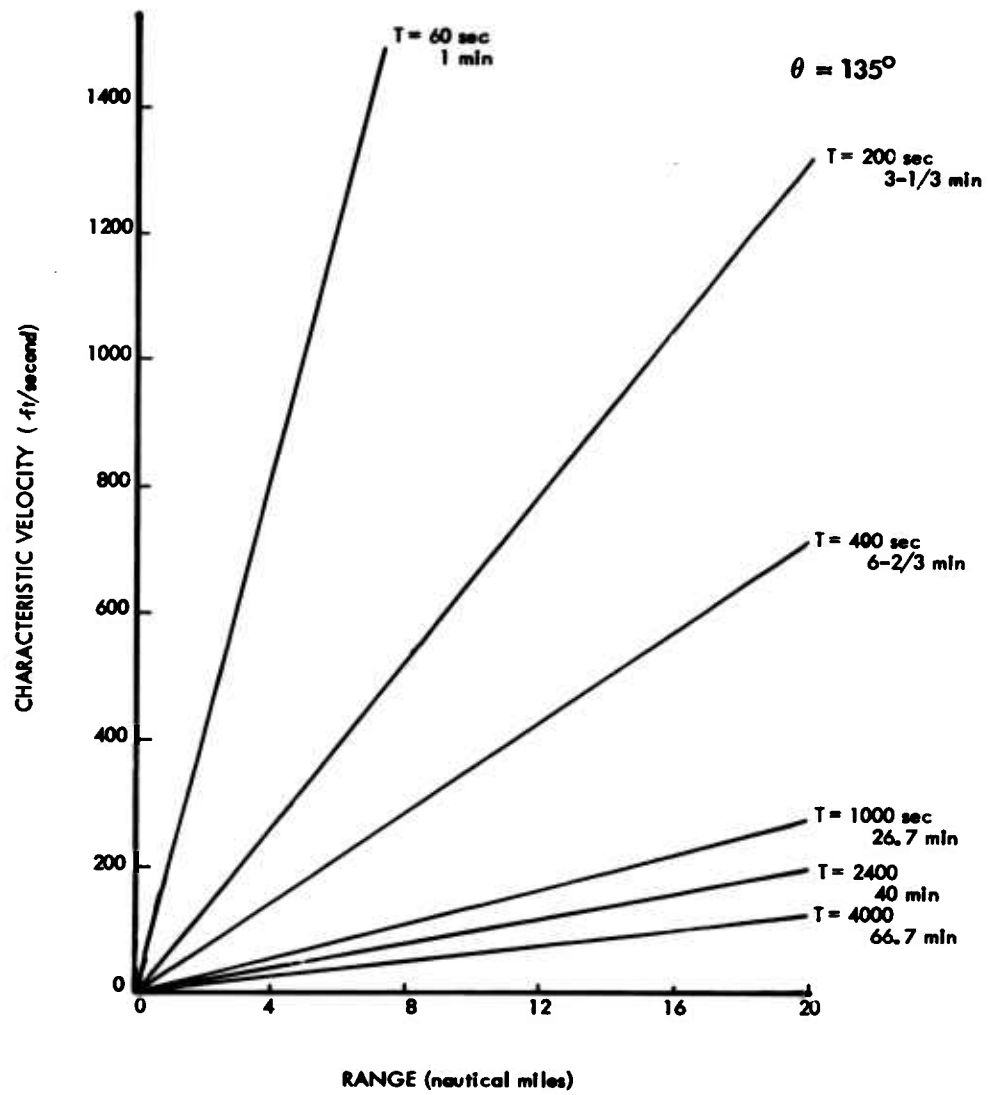

FIG. 4-14 MAXIMUM CHARACTERISTIC VELOCITY VS RANGE

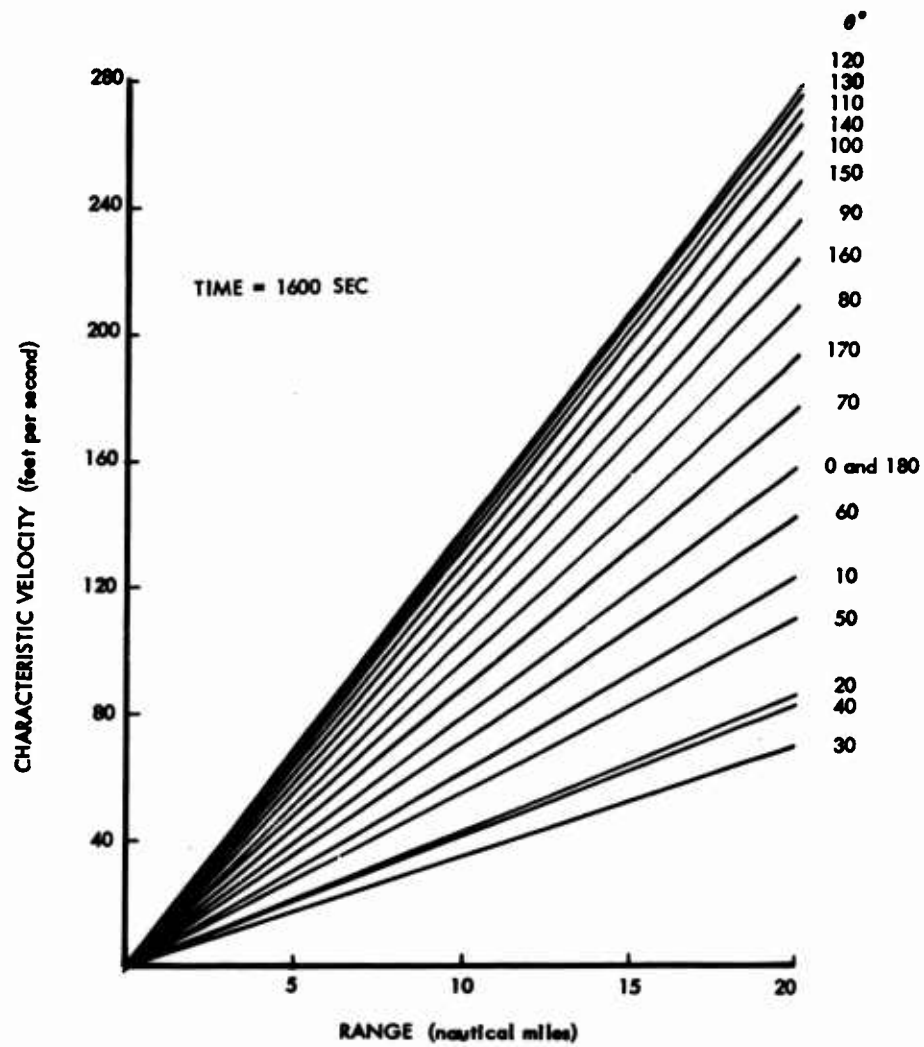

FIG. 4-15 CHARACTERISTIC VELOCITY VS RANGE

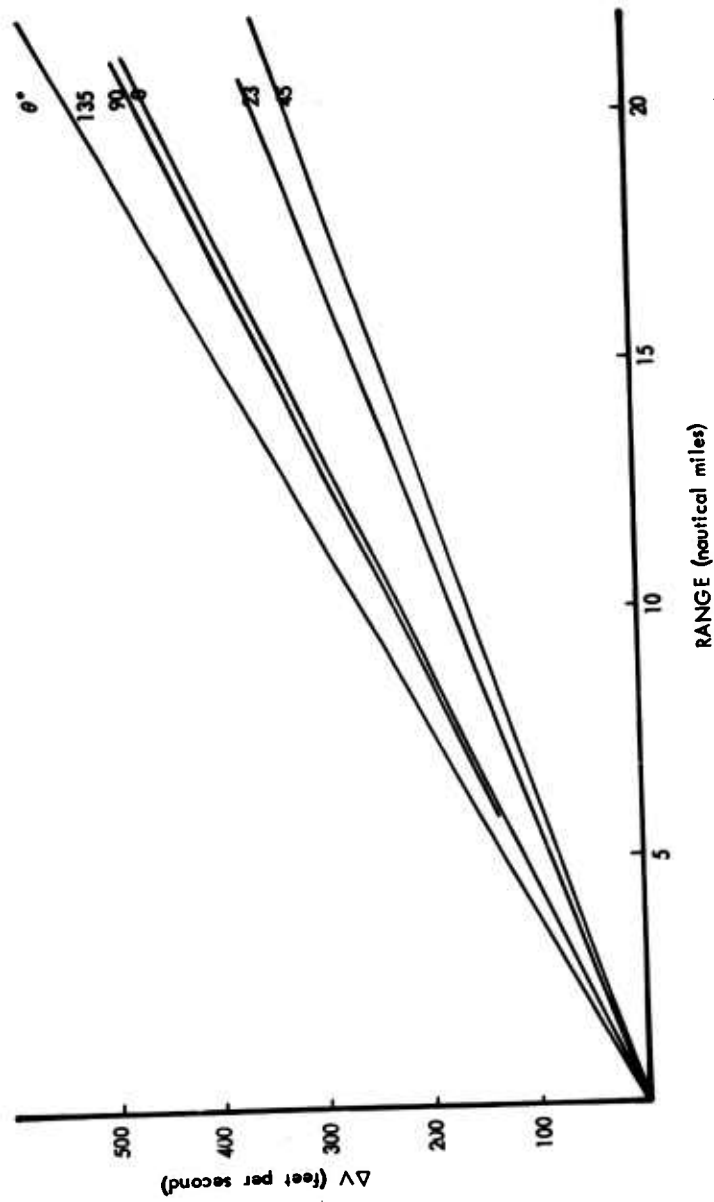

FIG. 4-16 CHARACTERISTIC VELOCITY VS RANGE TIME = 600 SEC

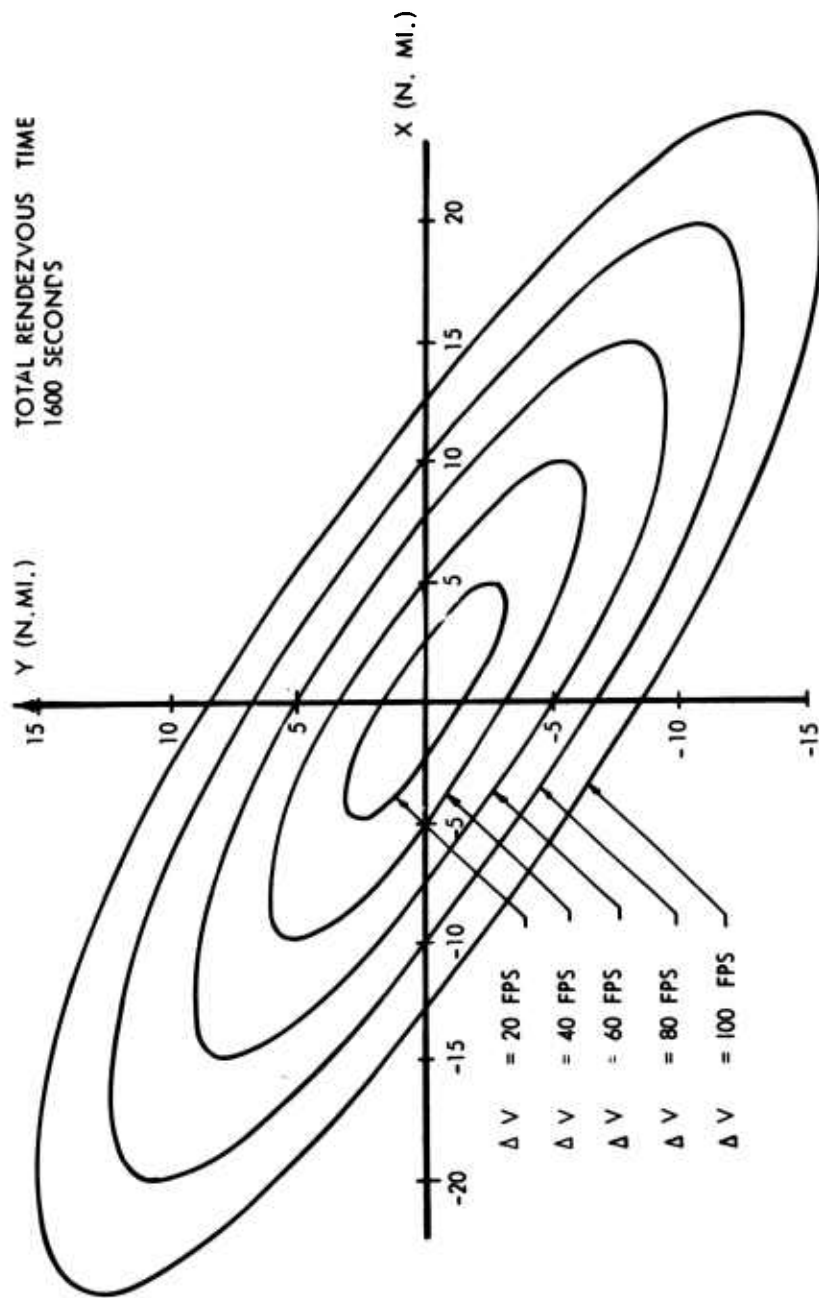
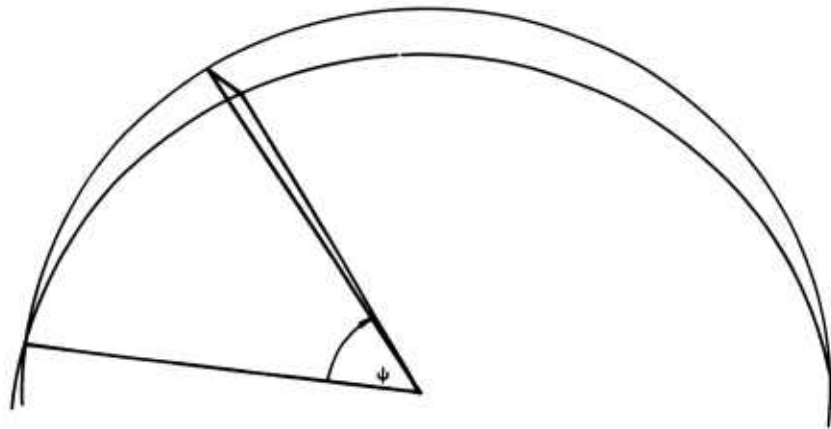

FIG. 4-17 CONTOURS OF CONSTANT CHARACTERISTIC VELOCITY



ψ = ANGLE OF VEHICLES FROM NODE

FIG. 4-18 ANALYTICAL MODEL

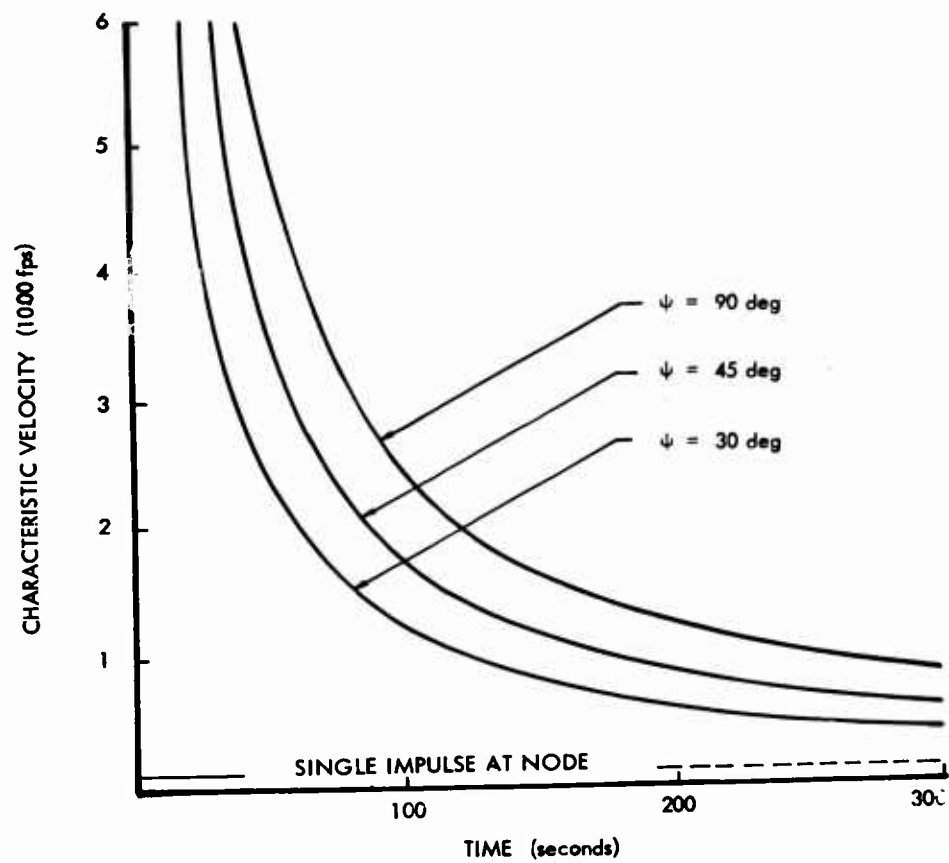

FIG. 4-19 CHARACTERISTIC VELOCITY VS TIME FOR SHORT-TIME, OUT-OF-PLANE RENDEZVOUS

4.4 RANGE VARIATION WITH TIME

4.4.1 Introduction

The problem under consideration is the variation of distance between two space vehicles in orbits with slightly different orbital elements. This becomes important in the study of a space shuttle traveling between a primary vehicle and a target vehicle. The total time for the shuttle mission is determined by the degree of accuracy with which the orbits can be matched. The effects of errors in position, velocity, and coplanarity are considered here. For this analysis, the effects of the propagation of each of the errors are considered separately.

The analytical model used in this study is illustrated in Fig. 4-20. The target vehicle is in a circular orbit at an altitude of 300 nautical miles. The target moves with a circular velocity of 24,875 feet per second or an angular rate of 0.001094 radians per second. The primary vehicle is launched from earth or a parking orbit and is injected into a circular orbit by an impulse rocket firing at the time of intersection of the target orbit. It is assumed the errors that occur during this maneuver will cause the primary vehicle to be injected into an orbit which is close to, but not coincident with, the target orbit. Consequently, the distance between the two vehicles will tend to increase with time due to the differences in orbital periods and velocities.

4.4.2 Altitude Error

The first error to be considered is an error in altitude of the primary orbit. At some initial time, the position of the primary vehicle with respect to the target is given by R , the linear range between the two vehicles, and θ , the angle below the local horizon of the target.

As a result of the difference in altitudes of the two orbits, there will be a difference in angular velocity:

$$\Delta\omega \approx \frac{3}{2} \frac{(\Delta r)}{r_T} \omega_T \quad (43)$$

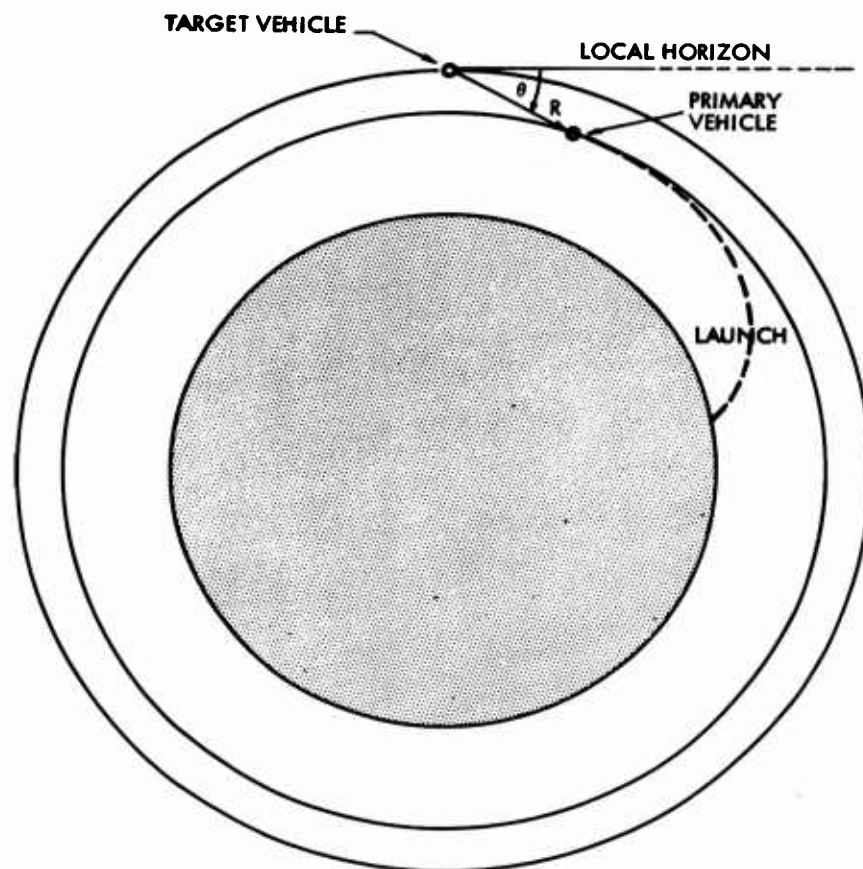

ALTITUDE OF TARGET ORBIT = 300 N. MI.

TARGET CIRCULAR VELOCITY = 24875 FPS

FIG. 4-20 ANALYTICAL MODEL

where r_T is the radius, ω_T the angular velocity of the target orbit, and Δr the difference in altitude of the two orbits. The variation of distance as a function of time is shown in Fig. 4-21. The initial linear range is fixed at 20 nautical miles and curves are plotted for values of the angle (0 deg, 45 deg and 90 deg). When $\theta = 0$ deg, the two vehicles are orbiting at the same altitude and the distance between them will remain constant as one trails the other around the orbit. When $\theta = 90$ deg, the result is a sinusoidal curve with minimum distance at time = 0 and an approximate period of eight days. The result for $\theta = 45$ deg is also a sine curve, but with a longer period and a minimum distance after approximately ten minutes. It should be noted that these values for the difference in altitude are somewhat larger than the expected errors. The greater values were chosen in order to present a more illustrative example of the propagation of an altitude error. However, even a small error in altitude will greatly affect the distance between vehicles. As an example, if the difference in altitude is 1000 feet, the distance between the vehicles will be approximately 28 nautical miles after a day.

4.4.3 Velocity Error

When investigating the effect of an error in velocity, it is assumed that the primary vehicle intercepts the target exactly, but that there is a small error in the velocity impulse. This causes the primary vehicle to be injected into an elliptical rather than a circular orbit. A three-sigma value of ± 16.2 feet per second was used as the error in tangential injection velocity. The effect of an error of this magnitude is shown in Fig. 4-22. It can be seen from the figure that the separation tends to increase with time, although for the first few hours it is approximately sinusoidal in nature.

4.4.4 Orbit Plane Error

The third source of error to be considered is caused by an inability to match the target orbit plane exactly. The motion of the primary vehicle with respect to the target is given by the equation:

$$\ddot{Z} + \omega^2 Z = 0 \quad (44)$$

where r_T is the radius, ω_T the angular velocity of the target orbit, and Δr the difference in altitude of the two orbits. The variation of distance as a function of time is shown in Fig. 4-21. The initial linear range is fixed at 20 nautical miles and curves are plotted for values of the angle (0 deg, 45 deg and 90 deg). When $\theta = 0$ deg, the two vehicles are orbiting at the same altitude and the distance between them will remain constant as one trails the other around the orbit. When $\theta = 90$ deg, the result is a sinusoidal curve with minimum distance at time = 0 and an approximate period of eight days. The result for $\theta = 45$ deg is also a sine curve, but with a longer period and a minimum distance after approximately ten minutes. It should be noted that these values for the difference in altitude are somewhat larger than the expected errors. The greater values were chosen in order to present a more illustrative example of the propagation of an altitude error. However, even a small error in altitude will greatly affect the distance between vehicles. As an example, if the difference in altitude is 1000 feet, the distance between the vehicles will be approximately 28 nautical miles after a day.

4.4.3 Velocity Error

When investigating the effect of an error in velocity, it is assumed that the primary vehicle intercepts the target exactly, but that there is a small error in the velocity impulse. This causes the primary vehicle to be injected into an elliptical rather than a circular orbit. A three-sigma value of ± 16.2 feet per second was used as the error in tangential injection velocity. The effect of an error of this magnitude is shown in Fig. 4-22. It can be seen from the figure that the separation tends to increase with time, although for the first few hours it is approximately sinusoidal in nature.

4.4.4 Orbit Plane Error

The third source of error to be considered is caused by an inability to match the target orbit plane exactly. The motion of the primary vehicle with respect to the target is given by the equation:

$$\ddot{Z} + \omega^2 Z = 0 \quad (44)$$

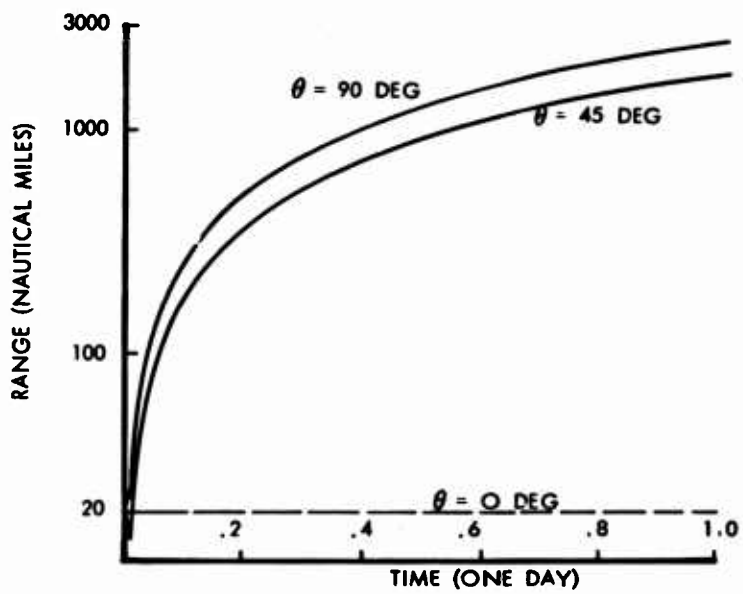
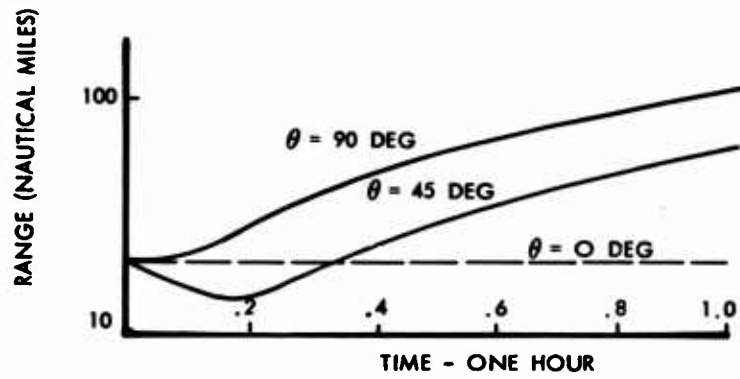

FIG. 4-21 PROPAGATION OF AN ERROR OF 20 N. MILES IN INITIAL POSITION

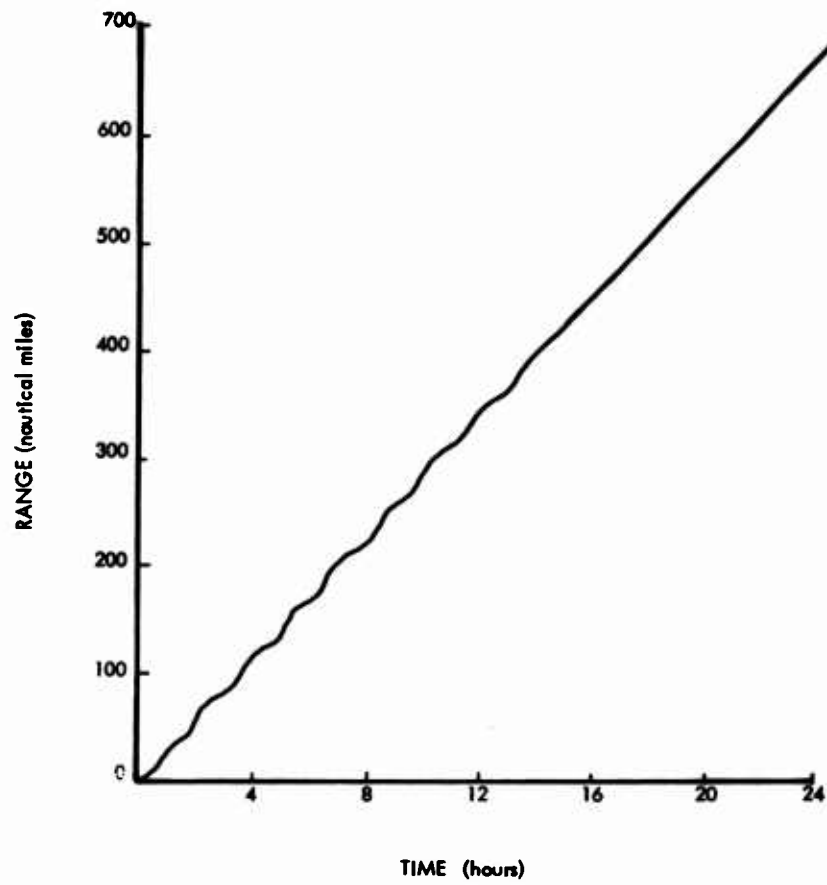

FIG. 4-22 PROPAGATION OF A TANGENTIAL ERROR OF 16.2 FPS IN THE INJECTION VELOCITY

where Z is the distance between the two vehicles. The solution of this equation is simply a sine curve. If there are no other injection errors, the maximum separation distance, occurring at intervals of approximately 48 minutes, will remain constant.

The three types of errors considered above are by no means the only ones possible in a maneuver of this sort. They were chosen for their representative value since the purpose of this study is to present the gross effects of injection errors. The information presented here, particularly in the cases of altitude and velocity errors, supports the opinion that as mission times increase, the design of the shuttle vehicle will necessarily become more sophisticated.

4.5 THE FORCES REQUIRED TO MAINTAIN TWO SPACE VEHICLES IN CONSTANT RELATIVE POSITION

4.5.1 Introduction

Two bodies orbiting at a close distance will maintain their relative distance and angular position only if both are in exactly the same orbit and merely separated in phase, i. e., in flight path direction. The forces that are necessary to maintain two bodies in the same relative position are found in this section. There are various possible applications of this problem, for instance the requirement to hold a smaller vehicle at a given distance from a larger space station or the task of shuttle to inspect the station from outside. This study also computes the ΔV required to eliminate the drift shown in Sect. 4.4.

For simplification, it is assumed that one vehicle is to be controlled in its position with reference to a second vehicle that stays fixed in its orbit.

It is furthermore assumed that the vehicle's initial condition has been brought into the desired position. The correction of a misalignment constitutes a separate problem.

4.5.2 Equal Altitude Station Keeping

If the vehicle is supposed to stay at the side and at the same altitude, then its orbit differs from the station's orbit only in that both are slightly out of plane. The resulting flight path, when uncontrolled, is expressed by the distance

$$y = y_0 \cos(\omega t) \quad (45)$$

where y_0 is the initial distance, ω the angular velocity, and $t =$ time. The acceleration causing the indicated change in distance y is found by differentiation:

$$a_y = \frac{d^2 y}{dt^2} = -\omega^2 y_0 \cos(\omega t) \quad (46)$$

which acceleration at the time $t = 0$ is

$$a_y = -\omega^2 y_0 \quad (47)$$

or

$$= -\frac{\mu}{r^3} y_0$$

when

$$\omega = \sqrt{\frac{\mu}{r^3}} \quad (\text{for small eccentricities})$$

To maintain the vehicle at the initial distance y_0 , this acceleration has to be continuously compensated by an equivalent thrust in the opposite direction, namely away from the station. Values for various distances y_0 in an orbit at 500 km (310 n.mi) altitude are shown in Table 4-1.

To evaluate the total expenditure of propellant required to maintain the desired distance over a given time period, the accumulated $\Sigma \Delta v = a_y T$ is also shown in the table.

TABLE 4-1

ACCELERATION REQUIRED TO STAY AT VARIOUS DISTANCE Y_0

$\pm y_0$	$\pm a_y$	T (min)	$\Sigma \Delta v$ (fps)
10.9 n.mi	$2.47 \times 10^{-3} g$	10	47.0
10.9 n.mi	$2.47 \times 10^{-3} g$	30	142.0
10.9 n.mi	$2.47 \times 10^{-3} g$	60	285.0
0.621 n.mi	$1.23 \times 10^4 g$	10	2.38
0.621 n.mi	$1.23 \times 10^4 g$	30	7.1
0.621 n.mi	$1.23 \times 10^4 g$	60	14.2
328 ft	$1.23 \times 10^{-5} g$	10	0.24
328 ft	$1.23 \times 10^{-5} g$	30	0.71
328 ft	$1.23 \times 10^{-5} g$	60	1.42
65.6 ft	$2.47 \times 10^{-6} g$	-	-
32.8 ft	$1.23 \times 10^{-6} g$	-	-

4.5.3 Station Keeping Directly Above or Below Target

If the vehicle is supposed to stay above or underneath the station at a distance dr (indicating the difference in orbit radius) it is not in exactly the same orbit. When above the station, it will travel too fast with respect to the increased orbital radius ($r + dr$) and, therefore, gain altitude.

To force it to stay down, one has to compensate for the change in radial acceleration caused by the increased radius. The radial acceleration when in the same orbit as the station with the horizontal velocity V and the radius r given by

$$a_r = \frac{\mu}{r^2} - \frac{V^2}{r} \quad (48)$$

where

μ = gravitational field constant

Hence

$$a_r = \frac{\mu}{r^2} - \omega_o^2 r \quad (49)$$

and the change in a_r , holding ω_o constant

$$da_r = \left(-2 \frac{\mu}{r^3} - \omega_o^2 \right) dr \quad (50)$$

Since for small eccentricities

$$\omega_o = \sqrt{\frac{\mu}{r^3}}$$

Then

$$da_r = \left(-2 \frac{\mu}{r^3} - \frac{\mu}{r^3} \right) dr = -3 \frac{\mu}{r^3} dr = a_z \quad (51)$$

One might note that a_z is three times the amount a_y found for the y direction. As a numeric example, the same representative orbit as above with 500 km altitude is selected and the amount of acceleration a_z computed as required to stay at various distances z_o . This is given in Table 4-2.

4.5.4 Conclusion

The conclusion to be drawn from above, for a vehicle provided with means to sense and control angle and distance is that the amount of propellant required for continuous or intermittent correction in maintaining a constant distance is:

- none when on the same flight path leading or lagging the station
- moderate when over or underneath the station
- small when out of plane to the side

Table 4-2

ACCELERATION REQUIRED TO STAY AT VARIOUS DISTANCE z_0

$z_0 = \pm dr$	$az = \pm da_r$	T (min)	$\Sigma\Delta V$
10.9 n.mi	$7.41 \times 10^{-3} g$	10	142
10.9 n.mi	$7.41 \times 10^{-3} g$	30	426
10.9 n.mi	$7.41 \times 10^{-3} g$	60	852
0.621 n.mi	$3.69 \times 10^{-4} g$	10	7.1
0.621 n.mi	$3.69 \times 10^{-4} g$	30	21.3
0.621 n.mi	$3.69 \times 10^{-4} g$	60	42.6
328 ft	$3.69 \times 10^{-5} g$	10	0.71
328 ft	$3.69 \times 10^{-5} g$	30	2.13
328 ft	$3.69 \times 10^{-5} g$	60	4.26
65.6 ft	$7.41 \times 10^{-6} g$	-	-
32.8 ft	$3.69 \times 10^{-6} g$	-	-

4.6 RENDEZVOUS TECHNIQUES

A rendezvous technique for use with the shuttle is defined in this section. The requirements for the navigation and guidance system are stated and the applicability of visual tracking and the required sensor precision is determined. Variations of the SMU technique and a technique using data transmitted from the primary are evaluated. The recommended technique is described in Section 4.6.8.

4.6.1 Navigation and Guidance Operational Criteria

The operational criteria necessary to determine the characteristics of the navigation and guidance system are summarized below:

Assumptions:

1. Determination of the target's orbital characteristics is made by the primary vehicle prior to shuttle departure.
2. All computations required for thrust vector control are performed on-board the primary vehicle.
3. The shuttle is normally in visual contact with the target prior to departure from the primary vehicle. Where visual contact cannot be achieved owing to the target being in the earth's shadow, direct sunlight or other unfavorable conditions, the primary (with shuttle) either maneuvers to where favorable conditions prevail, waits until visual contact is made, or establishes contact by radar.

Requirements and Constraints

1. The guidance system must be capable of performing the navigational tasks involved in inter-orbital maneuvers between the primary vehicle and targets within a 20 n. mi. range.
2. To ensure a high probability of mission success, the system must operate with minimum dependence on the primary vehicle, and minimum complexity of system design.
3. The system must be capable of performing without reliance upon target augmentation such as flashing lights, radio beacons, activated heat sources or other devices requiring cooperative design of the target.

4. The system must not depend upon visual tracking of the target throughout the entire rendezvous maneuver.
5. The system must be sufficiently flexible to provide back-up guidance modes without duplication of units or addition of facilities not normally consigned to the shuttle for performing its missions.
6. For ease of mechanization and increased reliability, maximum utility must be made of man as a sensing system and as a controller in the guidance loop.

4.6.2 Target Acquisition and Tracking

References (4-3 and 4-4) consider the problem of vision in a qualitative manner, and point out that some situations will pose difficult problems of target identification. To ensure that the shuttle system be simple, and in order to specify ranges to determine propellant requirements, a study was undertaken to determine the distance at which visual acquisition of the target is or is not possible.

4.6.2.1 Orbital Situations - Geometrical Aspects

Figure 4-23 illustrates the relative positions of the satellites, the Earth, and the Sun. The following three relative positions at various points in the orbit are of interest:

1. The target is in the shadow of the Earth.
2. The target is illuminated by the Sun and by reflected light from the Earth and is viewed with the sky in the background.
3. The target is illuminated by the Sun and the Earth and is viewed with the Earth as a background.

A number of other situations may occur, but are not important because they occur infrequently or do not last for an appreciable length of time. Such transient conditions include the Sun directly behind the target, the moments of entry into and exit from the Earth's shadow, and those cases when moonlight is the only illumination on the target.

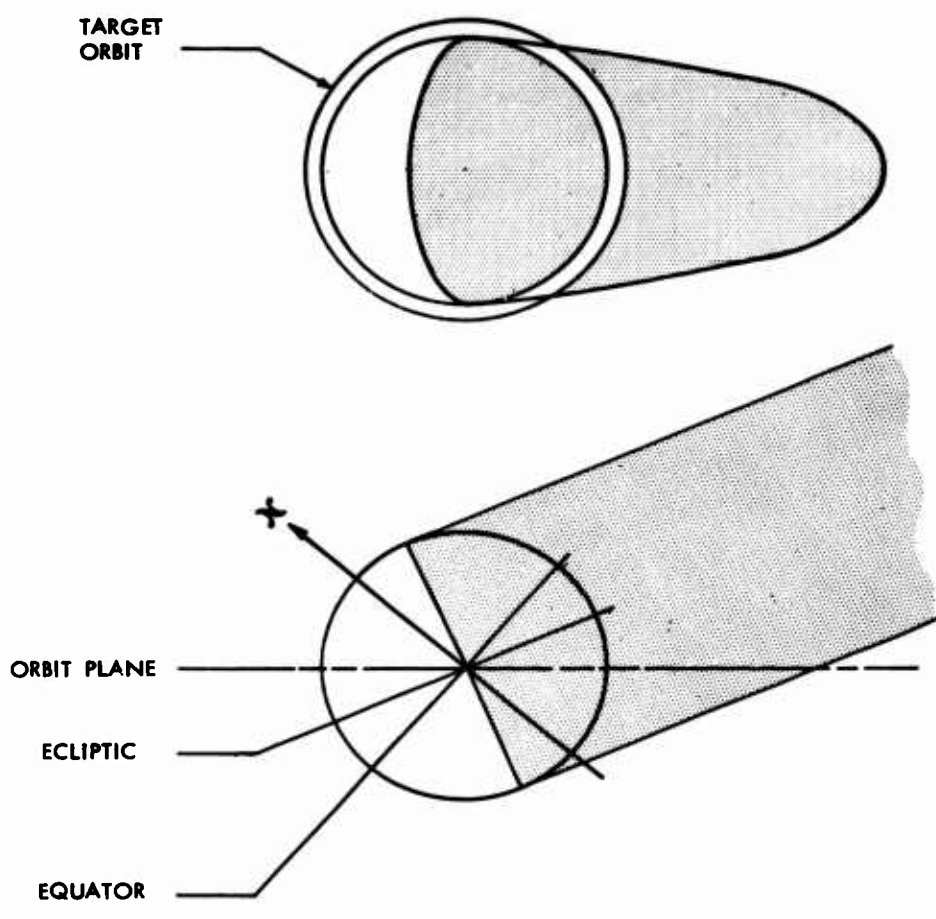

FIG. 4-23 LIGHTING GEOMETRY

4.6.2.2 Time Spent in Each Situation

The strongest influence on the visual situation is the eclipse occurring each revolution as the satellites pass behind the Earth. Figure 4-24 shows the time spent in the shadow of the Earth per revolution, for orbits of 300-n. mi. and 500-n. mi. altitude. The abscissa is the inclination of the orbit to the equator. The shadow time is shown for both the time of year at which the angle between the orbit plane and the equator is greatest, and when the ecliptic intersects the orbit plane. It is anticipated that the manned systems of interest to the shuttle will be launched from the Atlantic Missile Range and that the inclinations will, therefore, be over 30 deg, but below 60 deg. These satellites will therefore spend over a half hour per revolution in shadow, approximately one-third of the time. Only the near-polar orbits launched from the Pacific Missile Range will escape appreciable shadow time, and then only part of the year.

As shown in Figure 4-25, the Earth occupies a very large portion of the total visual field. If no restriction is placed on the relative altitude of target and shuttle, the shuttle views the target with the Earth as a background more than 25 percent of the time for altitudes less than 500 n. mi.

4.6.2.3 Target Magnitude With Star Background

For positive acquisition, it is felt that the target should appear brighter than any other object in view except the Sun and Moon. A visual magnitude of -3 is therefore selected as a minimum brightness to be considered. Movement cues are ignored as the rendezvous maneuver, especially for short transfer, tends to null the line-of-sight rate. With this magnitude, the relationships of Ref. 4-1 have been used to calculate the range for targets of various diameters. The results are plotted in Fig. 4-26. The formula for specular reflection has been used which gives the same result as that for diffuse reflection when the angle from the observer to the target to the Sun is 87 degrees. At smaller angles, the diffuse reflectors will appear even brighter. A reflectivity of 0.15 is assumed which corresponds to the reflectivity of solar cells and is as low as is expected of typical targets.

i_{\odot} GEOCENTRIC ANGLE BETWEEN
SUN AND ORBIT PLANE

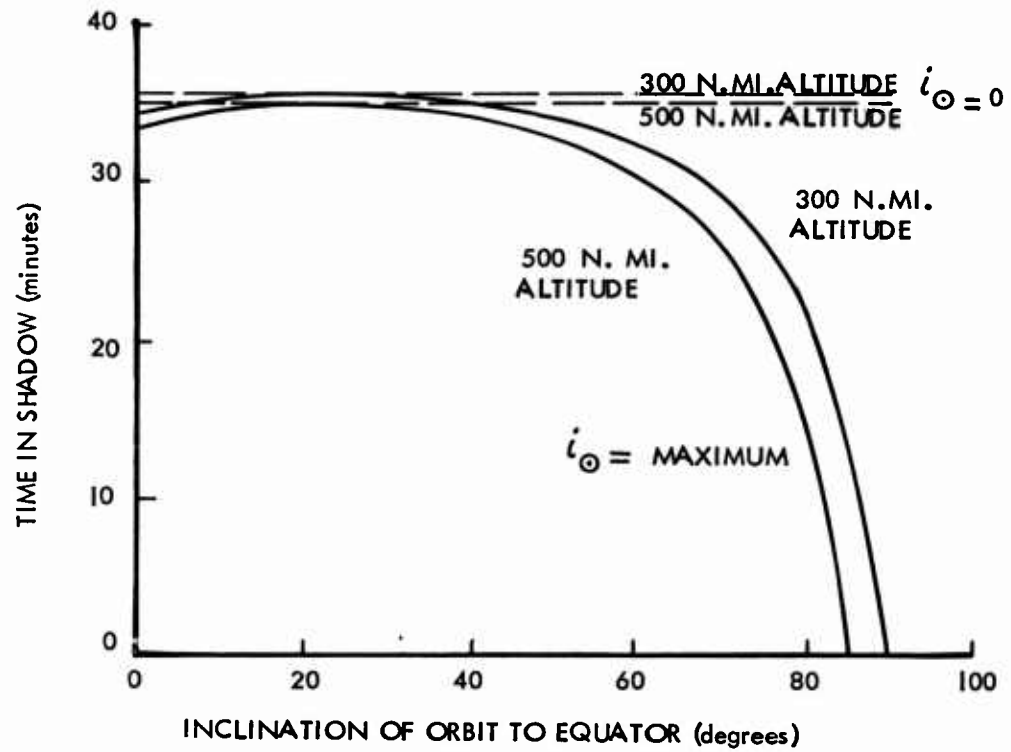

FIG. 4-24 DURATION OF ECLIPSE AS A FUNCTION OF ORBIT
INCLINATION

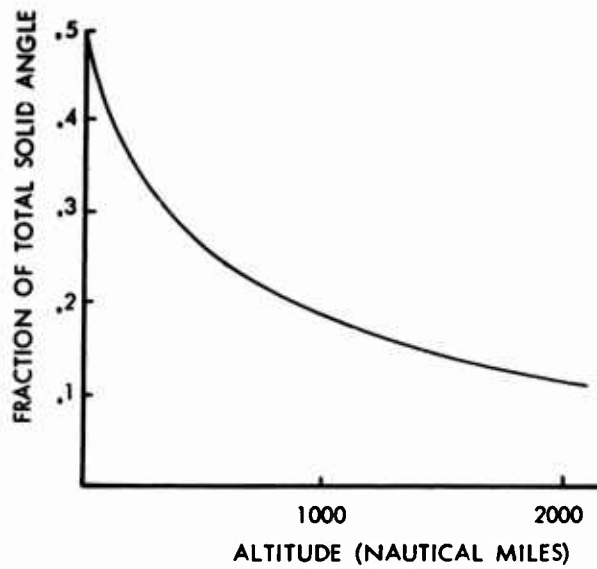

FIG. 4-25 VISUAL ANGLE OBSTRUCTED BY EARTH

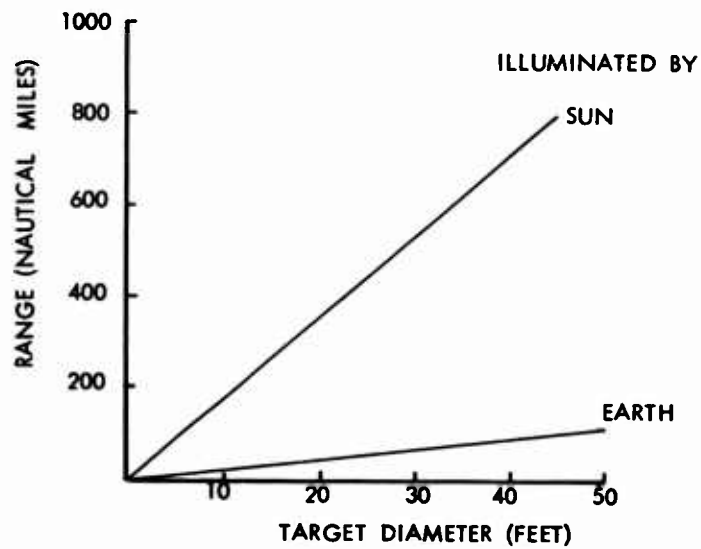

FIG. 4-26 TARGET RANGE VS DIAMETER, VISUAL MAGNITUDE -3

4.6.2.4 Target Magnitude with Star Background and Target Illuminated by Earth. A calculation of visual magnitude against target diameter has been made for the target illuminated by Earth, also shown in Fig. 4-26 . The same type of target was considered and the illumination was based on an average albedo of 0.35 for the Earth. Although not as bright as the sunlit case, it is evident that identification will be positive for this case.

4.6.2.5 Target Viewed Against the Bright Earth. The Earth constitutes a very large reflector and the illumination at orbital height from this source is great. Using the albedos for various type surfaces as given in Ref. 4-2 the illumination at 300 n. mi. is shown in Table 4-3. These are values at the eye of an observer with a 20-deg field of view through his port. Even for the lowest albedos, a high illumination is indicated. The illumination at the observer corresponding to a target of visual magnitude -4.8 (a target subtending an angle of 12 minutes at the observer) is only 5.35×10^{-4} ft candles, and while the satellite might be brighter than the background, it would be very difficult to distinguish it against the glare. As indicated both by photographs taken from satellites and by the range of illuminations shown for various surface conditions, the target is viewed against a mottled background. Identifying the small disk of the target against such a background is expected to be extremely difficult. Since this situation occurs about one-third of the time while the satellites are in the Sun, which in turn is two-thirds of each revolution, this represents over 20 percent of the situations that might occur.

4.6.2.6 Conclusions. This study indicates that visual identification of the target is reliable only about one-half of the time. For those situations in which the target is not illuminated by the Sun, the probability of detection is very low. The target cannot be seen when in the shadow of the Earth, which occurs over 30 percent of the time. The probability of acquiring the target when viewed against the bright Earth is very low. This situation occurs about 20 percent of the time. Therefore, visual acquisition of the target is reliable only about one-half of the time and visual aid is required if all missions are to be performed reliably.

Table 4-3
 TARGET ILLUMINATION BY EARTH - 300 N. MI.

<u>Earth Surface</u>	<u>Surface Albedo*</u>	<u>Illumination from Earth (ft candles)</u>
Ocean	0.03-0.05	354-590
Dry Grass	0.03-0.06	354-710
Deciduous Forest	0.03-0.10	354-1180
Ground	0.10-0.20	1180-2360
Rocks	0.30	3540
Lush Grass	0.15-0.25	1770-2950
New Snow	0.70-0.86	8250-10200
Clouds (average)	0.5	5900

* These values are believed to be somewhat high for visual range.

4.6.3 Sensor Precision Required

4.6.3.1 Analytical Model. It has been previously determined that practical guidance techniques for shuttle operations will be based upon proportional navigation methods. Before specific techniques for performing the guidance tasks could be judged, an understanding of the kinematics of the problem is necessary. An analytical model of the guidance system is developed to determine the pilot's information requirements for performing proportional navigation. Then, a simplified error analysis is made to determine the accuracy with which the necessary parameters must be presented.

The following development is presented as a view of the kinematics of the shuttle-target relationship. The formulation leads to a kinematic equation of motion, in three dimensions, which shows the influence of controlled variables on the navigation variables as seen by the shuttle fixed observer.

The following symbols are introduced:

\vec{R}_p \equiv The position vector from the center of the Earth to the primary vehicle.

\vec{R}_s \equiv The position vector from the center of the Earth to the shuttle.

\vec{R}_T \equiv The position vector from the center of the Earth to the target.

ϕ_s \equiv A shuttle-fixed coordinate system having axes S_1 , S_2 , and S_3 . Along each axis is a unit vector $\vec{1}_{si}$ ($i = 1, 2, 3$).

Similarly ϕ_p , ϕ_T and ϕ_I are coordinate systems whose axes are, respectively fixed relative to the parent vehicle frame, the target frame and inertial frame. Axes and unit vectors are symbolized analogously to the convention for ϕ_s

$\vec{\Delta R}_T$ \equiv $\vec{R}_T - \vec{R}_s$

$\vec{\Delta R}_p$ \equiv $\vec{R}_p - \vec{R}_s$

$\vec{\omega}_s$ \equiv Angular velocity of ϕ_s with respect to ϕ_I

$\vec{\omega}_p$ \equiv Angular velocity of ϕ_p with respect to ϕ_I

$\vec{\omega}_T$ \equiv Angular velocity of ϕ_T with respect to ϕ_I

μ \equiv Earth's gravitational constant = 1.41×10^{16}

$\vec{G}(\vec{R})$ \equiv Gravitational field at point \vec{R}

$\left. \frac{d\vec{M}}{dt} \right|_Q$ \equiv The time derivative of any vector, \vec{M} , as seen by an observer fixed in ϕ_Q

$\vec{\omega}_\Delta$ \equiv Angular velocity of unit vector $\vec{1}_\Delta$ with respect to ϕ_s

$\vec{1}_\Delta$ \equiv Unit vector pointing along line of sight from the shuttle to the target

The frame of interest is ϕ_s . Thus, it is the behavior of $\vec{\Delta R}_T$ as seen by the ϕ_s observer that must be considered. The following relation is a complete equation of motion inclusive of forces that are propulsive and gravitational:

$$\left. \frac{d\vec{\Delta R}_T}{dt} \right]_s = \left. \frac{d\vec{R}_T}{dt} \right]_I^\circ - \left. \frac{d\vec{R}_s}{dt} \right]_I^\circ - \vec{\omega}_s \times \vec{\Delta R}_T + \int_{t_0}^t [\vec{G}(\vec{R}_T) - \vec{G}(\vec{R}_s)] dt' - \int_{t_0}^t \frac{\vec{T}}{M_s} dt' \quad (52)$$

where $\left. \frac{d\vec{R}_T}{dt} \right]_I^\circ$ and $\left. \frac{d\vec{R}_s}{dt} \right]_I^\circ$

are target and shuttle inertial (i. e. orbital) velocities at time $t = t_0$, and where $\frac{\vec{T}}{M_s}$ is the propulsive acceleration acting on the shuttle. Previously it was stated that the practical guidance techniques are all based upon proportional navigation. As soon as the shuttle system begins operation, the pertinent variables are generated. A consequence is that only the "kinematic equation of motion" need be dealt with wherein the instantaneous difference between the inertial velocity of the target and that of the shuttle, $\vec{\Delta V}$, occurs, and it is not necessary to consider the force terms causing $\vec{\Delta V}$. That is, if $\vec{\Delta V}$ is interpreted as indicated above, (52) can be rewritten as

$$\left. \frac{d\vec{\Delta R}_T}{dt} \right]_s = \vec{\Delta V} - \vec{\omega}_s \times \vec{\Delta R}_T \quad (53)$$

If $\vec{i}_\Delta \equiv \frac{\vec{\Delta R}_T}{\Delta R_T}$, equation 53 can be shown to lead to the conclusion that

$$\left. \frac{d\vec{i}_\Delta}{dt} \right]_s = \frac{\vec{\Delta V}}{\Delta R_T} - \vec{\omega}_s \times \vec{i}_\Delta - \vec{i}_\Delta \frac{\dot{\Delta R}_T}{\Delta R_T} \quad (54)$$

Where $\dot{\Delta R}_T$ is simply the time derivative of the scalar magnitude of $\vec{\Delta R}_T$. If $\vec{\omega}_\Delta$ is used to indicate the angular velocity of \vec{i}_Δ relative to ϕ_s axes, then, since

$$\vec{\omega}_\Delta = \vec{i}_\Delta \times \left. \frac{d\vec{i}_\Delta}{dt} \right]_s \quad (55)$$

By (54) it can be seen that

$$\vec{\omega}_\Delta = \vec{i}_\Delta \times \frac{\vec{\Delta V}}{\Delta R_T} - \left[\vec{\omega}_s - \vec{i}_\Delta (\vec{\omega}_s \cdot \vec{i}_\Delta) \right] \quad (56)$$

crossing $\vec{1}_\Delta$ into each side of (56) yields

$$\vec{1}_\Delta \times \vec{\omega}_\Delta = \vec{1}_\Delta \times \left(\vec{1}_\Delta \times \frac{\Delta \vec{V}}{\Delta R_T} \right) - \vec{1}_\Delta \times \vec{\omega}_s \quad (57)$$

Expanding the cross triple product, multiplying throughout by ΔR_T , and transposing terms in equation (57) yields:

$$\Delta \vec{V} = \vec{1}_\Delta \dot{\Delta R}_T + (\vec{\omega}_\Delta + \vec{\omega}_s) \times \Delta \vec{R}_T \quad (58)$$

where $\dot{\Delta R}_T$ reappears as $\vec{1}_\Delta \cdot \Delta \vec{V} = \dot{\Delta R}_T$.

(58) is an exact kinematic equation of motion used in the guidance techniques suggested. If, as is suggested below, the variables on the right are observed by sensors directly without need for integrations, the expression is limited in accuracy only by sensor performance and by accuracy and speed of calculation. Fig. 4-27 illustrates the suggested on-board information flow diagram. For manned operation $\Delta \vec{V}_p$, would be generated by the astronaut in accordance with his own decision making ability. However, it could be a wired-in $\Delta \vec{V}(\Delta \vec{R}_T)$ for automatic operation.

4.6.3.2 Accuracy Requirements of Measured Parameters

In practical application, the parameters of the kinematic equation are measured with devices having inherent error. The measured kinematic equation, therefore, has two components, one is the exact calculated parameter and the other is the error in measurement. The equation for measured velocity is written as follows:

$$\begin{aligned} \Delta \vec{V}_M = \Delta \vec{V} + \epsilon_{\Delta V} = & \left[(\vec{\omega}_s + \epsilon_{\omega_s}) + (\vec{\omega}_\Delta + \epsilon_{\omega_\Delta}) \right] \times \left[\Delta \vec{R}_T + \epsilon_{\Delta R_T} \right] \\ & + (\vec{1}_\Delta + \epsilon_{1_\Delta}) (\dot{\Delta R}_T + \epsilon_{\dot{\Delta R}_T}) \end{aligned} \quad (59)$$

Where $\epsilon_{\Delta V}$ is the error in measurement. ϵ is the designation for the error; the subscript shows the source of error.

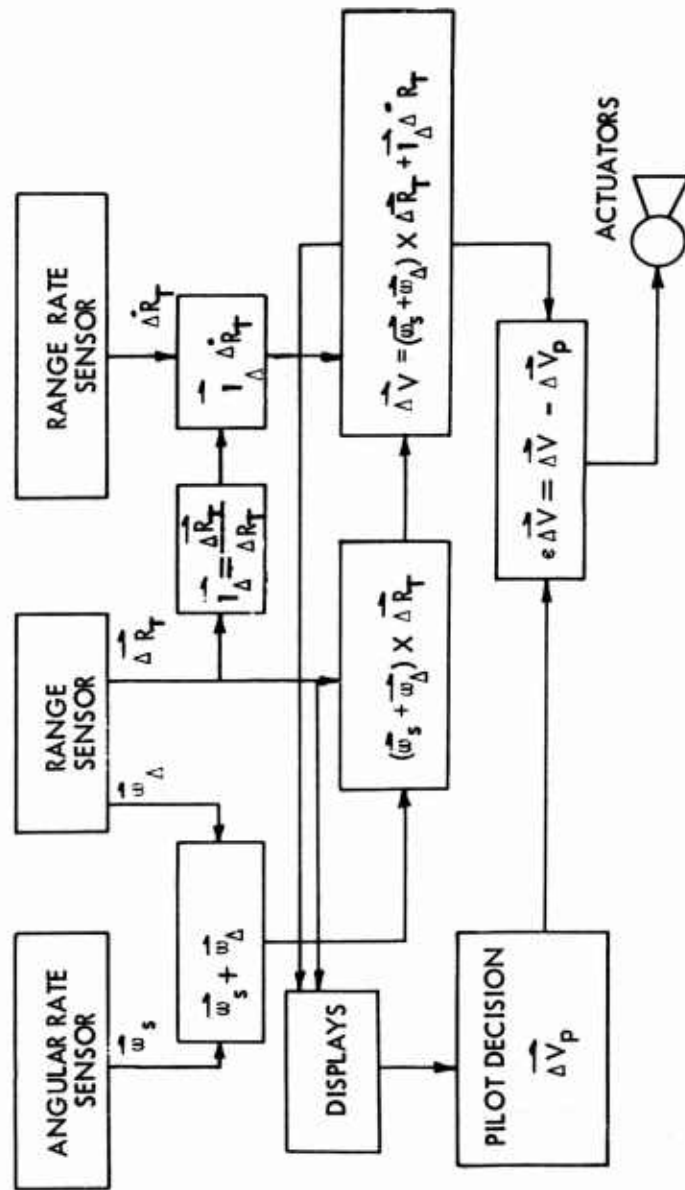

FIG. 4-27 SHUTTLE GUIDANCE SYSTEM SENSED INFORMATION AND TRANSFORMATION FOR PROPORTIONAL NAVIGATION

By expanding and separating equation (59) the following is obtained:

$$\begin{aligned} \vec{\Delta V}_M = \vec{\Delta V} + \vec{\epsilon}_{\Delta V} = & (\vec{\omega}_s + \vec{\omega}_\Delta) \times \vec{\Delta R}_T + \vec{1}_\Delta \dot{\Delta R}_T + \left(\vec{\epsilon}_{\omega_s} + \epsilon_{\omega_\Delta} \right) \times \vec{\Delta R}_T \quad (60) \\ & + (\omega_s + \omega_\Delta) \times \vec{\epsilon}_{\Delta R}_T + \vec{\epsilon}_{1_\Delta} \dot{\Delta R}_T + \vec{1}_\Delta \epsilon_{\dot{\Delta R}_T} + \left(\vec{\epsilon}_{\omega_s} + \vec{\epsilon}_{\omega_\Delta} \right) \\ & \times \vec{\epsilon}_{\Delta R}_T + \vec{\epsilon}_{1_\Delta} \epsilon_{\dot{\Delta R}_T} \end{aligned}$$

Assuming the errors to be equally distributed, the last two terms in equation (60) can be neglected because they are second order terms in ϵ .

The equation for $\vec{\epsilon}_{\Delta V}$ can be written by subtracting $\vec{\Delta V}$ from $\vec{\Delta V}_M$ in equation (60). The result is:

$$\vec{\epsilon}_{\Delta V} = \left(\vec{\epsilon}_{\omega_s} + \vec{\epsilon}_{\omega_\Delta} \right) \times \vec{\Delta R}_T + \left(\vec{\epsilon}_{\omega_\Delta} + \vec{\epsilon}_{\omega_s} \right) \times \vec{\Delta R}_T + \vec{\epsilon}_{1_\Delta} \dot{\Delta R}_T + \vec{1}_\Delta \epsilon_{\dot{\Delta R}_T} \quad (61)$$

The error in $\vec{\Delta V}$ is maximum where the trigonometric relationships between any two vectors are such that their product is equal to the product of the absolute magnitude of the vectors.

By squaring and summing the resulting errors the RSS for $\epsilon_{\Delta V}$ is:

$$|\epsilon_{\Delta V}|_{Rss} = \sqrt{\left[(\omega_\Delta + \omega_s) \max \epsilon_{\Delta R}_T \right]^2 + \left[\epsilon_{\omega_\Delta} \Delta R_T \max \right]^2 + \left[\epsilon_{\omega_s} \Delta R_T \max \right]^2} \left\{ \begin{aligned} & + \epsilon_{\dot{\Delta R}_T}^2 + \left[\epsilon_{1_\Delta} \dot{\Delta R}_T \max \right]^2 \end{aligned} \right. \quad (62)$$

If all error is assumed to be equally distributed and if each contributor is designated by $\epsilon_{1/5} \Delta V$, then the error equation can be written:

$$|\epsilon_{\Delta V}|_{Rss} = \sqrt{5 (\epsilon_{1/5} \Delta V)^2} \quad (63)$$

Solving equation (63) for $\epsilon_{1/5} \Delta V$ the following is obtained

$$\epsilon_{1/5} \Delta V = \frac{|\epsilon_{\Delta V}|_{Rss}}{\sqrt{5}} \quad (64)$$

For shuttle applications $|\epsilon_{\Delta V}|/R_{ss}$ should not exceed 1 fps. By substituting 1 fps into equation (64) the value for each contributor can be calculated.

$$\epsilon_{1/5 \Delta V} = \frac{1}{\sqrt{5}} = 0.43$$

Therefore, for a maximum velocity error of 1 fps each contributor is equal to 0.43.

4.6.3.3 Magnitude of Errors

The maximum distance from the target to the shuttle is 20 miles as specified earlier in the report. The maximum range rate is chosen to be 75 ft/sec and $(\omega_{\Delta} + \omega_s)$ is chosen to be 10 deg/sec maximum. Using these values the error sources may be calculated.

The error due to $\overline{\Delta R}_T$ is written:

$$\epsilon_{\Delta R_T} = \frac{0.43}{(\omega_{\Delta} + \omega_s)_{\max}} = \frac{0.43}{0.174} = 2.5 \text{ ft.}$$

Error due to $\overline{\omega}_{\Delta}$ and $\overline{\omega}_s$ is:

$$\epsilon_{\omega_s} = \epsilon_{\omega_{\Delta}} = \frac{0.43}{\overline{\Delta R}_T \max} = \frac{0.43}{10.5 \times 10^4} = 0.004 \times 10^{-3} \text{ rad/sec}$$

The error due to $\overline{\dot{\Delta R}}_T$ is:

$$\epsilon_{\dot{\Delta R}_T} = 0.43 \text{ ft/sec}$$

The error due to \overline{l}_{Δ} is:

$$\epsilon_{l_{\Delta}} = \frac{0.43}{\overline{\Delta R}_T \max} = \frac{0.43}{75} = 5.7 \times 10^{-3} \text{ rad (1/3}^\circ)$$

4.6.3.4 Measurement Accuracy

A maximum velocity error of 1 fps is assumed for required shuttle performance. Table 4-4 shows the accuracy of parameter measurements required to achieve this performance.

Table 4-4

TRAJECTORY VARIABLE MEASUREMENT REQUIREMENTS

Parameter	Symbol	Required Measurement Accuracy
1) Distance between shuttle and target	$\vec{\Delta R}_T$	± 2.5 ft independent of range
2) Relative velocity between shuttle and target	$\vec{\dot{\Delta R}}_T$	± 0.43 fps independent of range
3) Angular velocity of shuttle with respect to inertial coordinates	$\vec{\omega}_S$	± 0.004 mrad/sec at 20 miles; 0.08 mrad/sec at 1 mi.
4) Direction of sight line between shuttle and target	\vec{i}_Δ	-5.7 mrad at 75 fps
5) Angular velocity of sight line with respect to shuttle coordinates	$\vec{\omega}_\Delta$	± 0.004 mrad/sec at 20 miles; ± 0.08 mrad/sec at 1 mile

4.6.4 Review of the SMU Guidance Technique

4.6.4.1 Description of SMU Technique

To gain insight on mechanics of the SMU guidance technique, of Ref. 1-1, a brief description of its operation is given. The technique is intended as a method for a man with a "self maneuvering unit" to travel from a primary base to an orbiting target and return; the target range being a maximum of 30,000 ft.

- 1) On the basis of tracking data obtained on the primary vehicle, the worker is given his initial velocity impulse and direction.
- 2) The worker aligns himself with the target and departs with the given velocity vector. Initial thrust is maintained until he reaches some predetermined relative velocity.
- 3) As he precedes, a stabilization device precesses him so that his reference direction (\bar{T}_r) maintains a constant angle with the local horizon.
- 4) He tracks the target so that when it has an angular displacement (ϵ) of 10 deg in the vertical plane he applies thrust in the opposite direction (\bar{T}_u or \bar{T}_d).
- 5) The thrust is terminated when the apparent angular rate ($\dot{\epsilon}$) goes to zero, i. e., the target appears motionless.
- 6) The maneuver terminates at the target with a miss distance uncertainty of not more than 22 ft with a relative velocity of between 10 and 20 fps.

The technique is simple, and fairly economical from the standpoint of energy expenditure. It requires a very minimum of equipment and hence is reliable and well suited to short ranges for orbital day applications.

Because of the advantages that the technique offers, an analysis is made to determine its applicability to the shuttle.

4.6.4.2 Operating Range

The initial range from which the shuttle maneuver begins may be greater than that which the SMU guidance technique will satisfy. A practical solution to this problem is the use of alternate guidance modes. For example, the primary

vehicle could compute a two-impulse trajectory for the shuttle proportional navigation could be employed to get the shuttle to within a 6 mile region of the target. From this point the SMU method, or variation thereof, could be employed.

4.6.4.3 Target Tracking

In order to employ the SMU technique, continuous visual tracking of the target is necessary. Thus, without target augmentation its application is restricted to orbital day operations.

4.6.4.4 Visual Reference

Man's ability to adequately perform the tracking task by visual determination of angles and angular rates without the use of tracking aids is questionable. An inherent problem with the SMU technique is the absence of a position reference by which to judge the targets angular position and rate. This lack of reference could lead to large deviations from the desired flight path before corrective action is instituted. This, in turn, could lead to large terminal errors in position and velocity, and require the inefficient application of corrective impulses.

A visual reference can be easily provided in the shuttle. A "crosshair" indication would provide a visual reference against which the target image could be compared for angular information and corresponding thrust control. If a tracking device such as radar is used, a reticle could be superimposed on the crosshair to represent the target image.

4.6.4.5 Terminal Velocity

To successfully implement the SMU technique a relative terminal velocity of between 10 and 20 fps is required; greater than 10 fps to avoid missing the target and less than 20 fps to keep terminal decelerations within acceptable limits. Such contact velocities are unacceptable for Shuttle docking, and, higher transit velocities are desirable to minimize mission time. These higher transit velocities will require a braking maneuver just prior to contact, thus necessitating the need for range and relative velocity data. If visibility is adequate, man's visual acuity may provide range and closure rate sufficiently

accurate. Under conditions of poor visibility, ranging aids will be required. Since there are times when angular tracking aids are required, in addition to range data, radar becomes a practical device for the guidance system.

4.6.4.6 Convergence of the Solution

It is reported in ASD TDR-62-278 that under certain circumstances of thrust actuation, divergent solutions would exist. Convergency was certified for the theoretical model using the thrust actuation criteria cited in the review of the SMU guidance technique above. However, the sensitivity of errors to these thrust parameters are not reported. Since errors have a significant influence on the utility of the SMU technique it is necessary to make an assessment of their influence based on reasonably expected errors. A convergent (stable) solution in this context is one which oscillates about the target altitude with diminishing amplitude. A divergent (unstable) solution is one in which the oscillations about the flight path to the target increase in amplitude with time. It is evident that, should this occur, the ability of the control system to respond would be severely taxed and an unpredictable trajectory would result.

For convenience in studying the problem, a stability criterion related to that cited above was employed. For purposes of analysis, the behavior of the vertical component of velocity, before and after a correction impulse (\bar{T}_u or \bar{T}_d) is of interest. Specifically, if the vehicle goes into a correction with a vertical component of velocity \dot{Y}_0 and comes out at \dot{Y}_1 , an unstable solution is suggested where $\dot{Y}_1/\dot{Y}_0 > 1$. In the analysis the influence of orbital accelerations is neglected because a maximum error of only 8 percent is incurred in the assumed value of vertical acceleration; typically, it involves neglecting 1 percent of the total accelerations acting on the vehicle.

On the basis of the foregoing assumptions, the vertical acceleration (for a nominally horizontal flight path) is simply the acceleration A_d due to the correction thrust. The velocity coming out of the turn (using $\dot{\epsilon} = 0 + 1$ sec thrust termination criterion) is:

$$\dot{Y}_1 = \dot{Y}_0 - A_d (t + 1) \quad (65)$$

and the stability ratio is:

$$-\dot{Y}_1/\dot{Y}_0 = \frac{A_d}{Y_0} (t+1) - 1$$

In these equations, t is the time during which the rocket operates, and hence is the time from $\epsilon = \phi$ to $\dot{\epsilon} = 0$. In order to evaluate $-\dot{Y}_1/\dot{Y}_0$, it is necessary to estimate t .

The criterion for thrust termination is that the line of sight rotation rate to the target be zero. If the line of sight angle (with respect to the horizon) is ϕ , then

$$\phi = \tan^{-1} -Y/X \quad (66)$$

and

$$\frac{d\phi}{dt} = \frac{1}{r} [Y\dot{X} - X\dot{Y}] \quad (67)$$

where r is the target slant range. The criterion of $\dot{\phi} = 0$ is equivalent to:

$$Y\dot{X} = X\dot{Y}$$

The following substitutions may be made;

$$\begin{aligned} X &= X_c + \dot{X}_t \\ \dot{Y} &= \dot{Y}_0 - A_d t \\ Y &= X_c \tan \phi + \dot{Y}_0 t - 1/2 A_d t^2 \end{aligned}$$

Making substitutions,

$$\dot{X} (X_c \tan \phi + \dot{Y}_0 t - 1/2 A_d t^2) = (X_c + \dot{X}_t) (\dot{Y}_0 - A_d t)$$

or,

$$1/2 A_d t^2 \dot{X} + A_d X_c t - X_c (\dot{X} \tan \phi + \dot{Y}_0) = 0$$

Solving for t;

$$t = -\frac{X_c}{\dot{X}} \left[1 - \sqrt{1 + \frac{2 \dot{X} (\dot{X} \tan \phi + \dot{Y}_0)}{A_d X_c}} \right] \quad (68)$$

Since the target is centered on the rectangular coordinate axis and the shuttle approaches from the left, X_c is negative, \dot{X} positive. Hence, the time estimated by this relationship is positive, and the indicated sum beneath the radical becomes a difference when numerical values are applied.

From the foregoing, equations are available for the estimation of t and $-\dot{Y}_1/\dot{Y}_0$. Figures 4-28 and 4-29 show the behavior of the stability factor with target range (X_c) closing rate (\dot{X}) and vertical component of velocity at the time of correction (\dot{Y}_0). It is evident that the situation becomes less stable as the target is approached.

From Fig. 4-29 note that the instability factor decreases with increasing entry velocity \dot{Y}_0 . Thus for a given set of X_c , \dot{X} , ϕ , and A_d , there is a critical vertical component of velocity, $(\dot{Y}_0)_{crit.}$, such that $Y_1/Y_0 = 1$. The exit velocity (\dot{Y}_1) will be closer to $(\dot{Y}_0)_{crit.}$, than \dot{Y}_0 and if a large number of encounters are made with the thrust commencement boundary, the actual vertical component will tend to $(\dot{Y}_0)_{crit.}$

In regions where the plot of $-\dot{Y}_1/\dot{Y}_0$ vs. X_c is represented by horizontal lines Fig. 4-29. or lines of positive slope, a stable solution exists. In such cases, the vertical velocity will tend to $(\dot{Y}_0)_{crit.}$, and $(\dot{Y}_0)_{crit.}$, will be constant or diminishing as the target is approached.

Where the $-\dot{Y}_1/\dot{Y}_0$ vs. X_c plot (Fig. 4-29) has a negative slope, stable solutions are still possible, but in this case, $(\dot{Y})_{crit.}$ increases as the target is approached. For the cases considered in Figs. 4-28 and 4-29 $-\dot{Y}_1/\dot{Y}_0$ is essentially constant until the last 1000 feet. Because of the limited number of encounters with the thrust commencement boundary beyond this point, only a limited \dot{Y} rise beyond this point will occur.

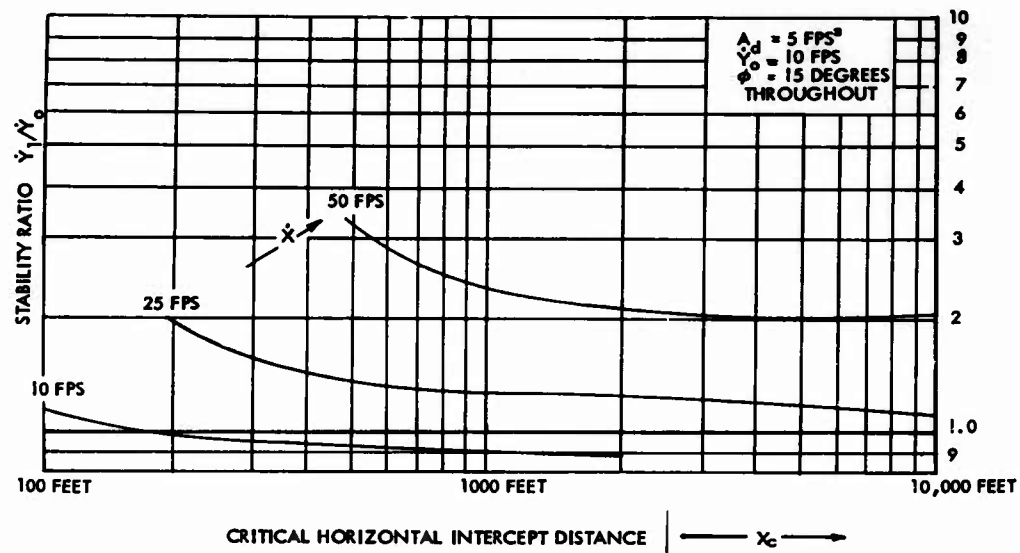

FIG. 4-28 STABILITY OF SMU TECHNIQUE (VARIABLE CLOSING RATE)

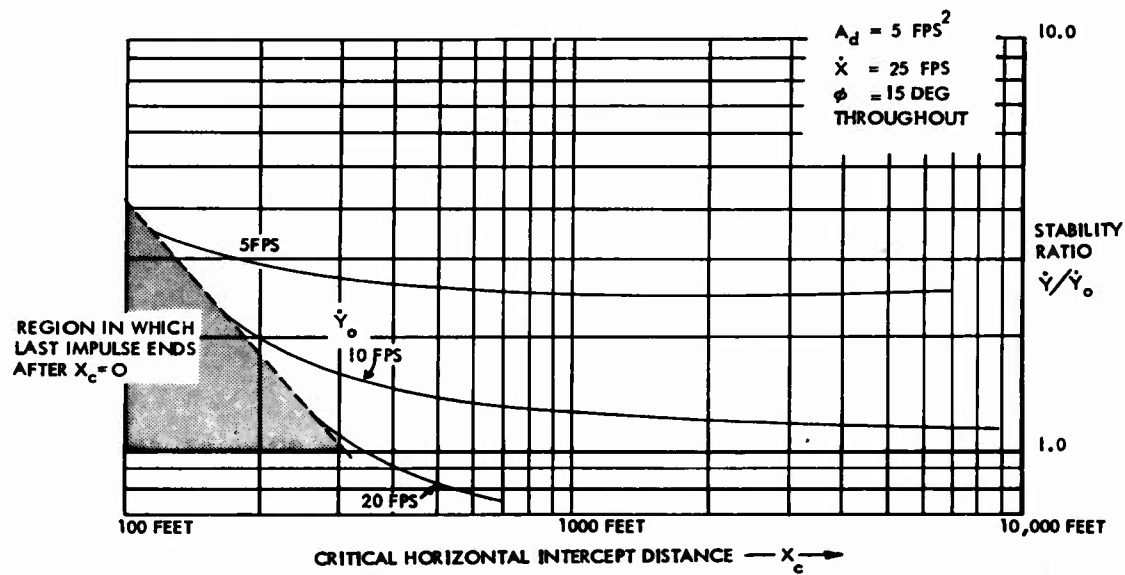

FIG. 4-29 STABILITY OF SMU TECHNIQUE (VARIABLE \dot{Y}_0)

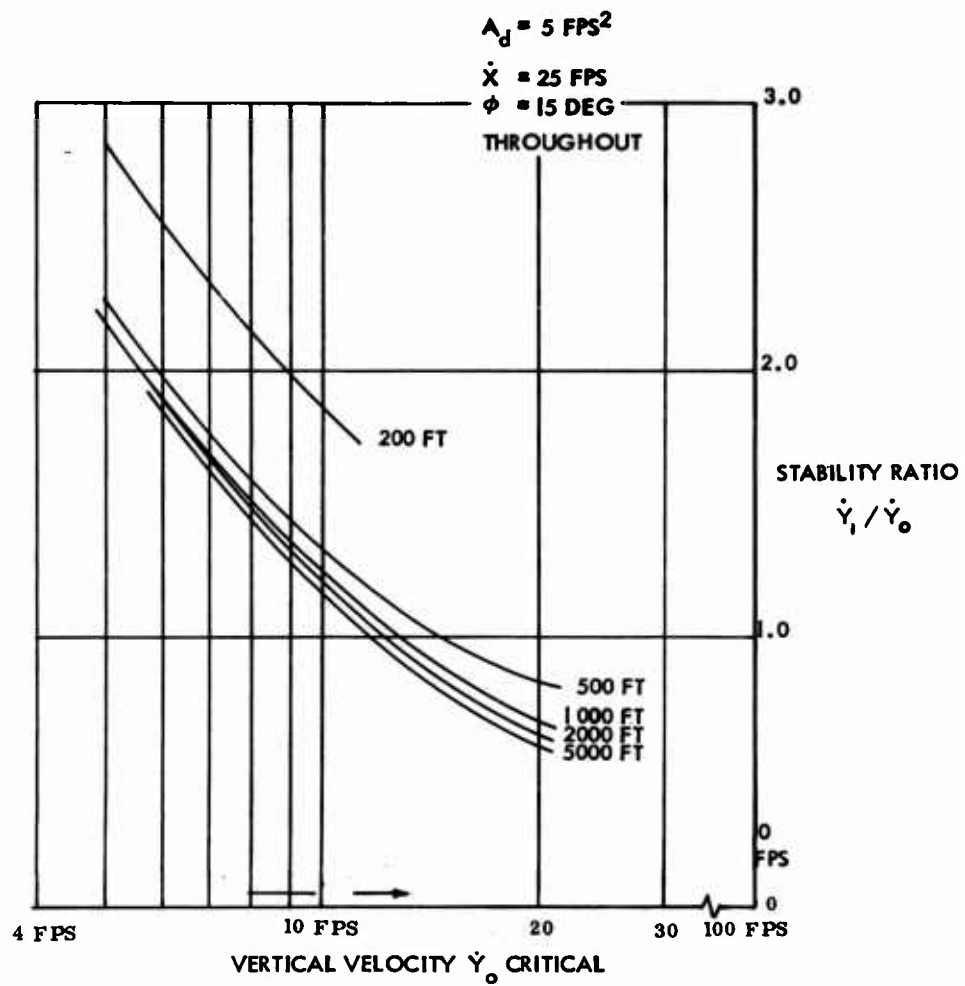

FIG. 4-30 CRITICAL VELOCITY FOR SMU TECHNIQUE

By plotting the instability factor against entry speeds, the value of (\dot{Y}_0) crit. may be found. This is done in Fig. 4-30, where the intersection of $-\dot{Y}_1/\dot{Y}_0 = 1$ and the curves give (\dot{Y}_0) crit. For the typical operating parameters considered, it is evident that as the target is approached, (\dot{Y}_0) crit. rises from about 11 to 25 fps.

From the foregoing analysis it may be observed that the SMU method, for the typical operating parameters considered in this analysis, and for a horizontal approach to the target, provides a stable solution with a maximum residual vertical component of velocity at the target of 5-20 fps; depending on the particular combination of operating parameters.

4.6.4.7 Terminal Error Considerations

Terminal errors are of considerable interest in judging the utility of the SMU technique. Several measures of terminal error are possible; perhaps the best would be the miss distance at closest approach. For analytic convenience, however, the Y-component of distance at X=0 will be taken as the measure of terminal error. Generally, this measure is not expected to differ by much from the miss distance at closest approach.

Fig. 4-31A shows the terminal situation schematically; the terminal miss distance is Y_0 and the angle at which the correction is initiated is θ . The X-axis is aligned with the horizontal. The point at which the correction is instituted has rectangular coordinates X_c, Y_c , and the correction itself consists of a downward acceleration of magnitude A_d . No braking is assumed to occur (thrust along the X-axis) during the maneuver.

Under the foregoing circumstances, the X-component of velocity will be essentially constant throughout the maneuver. An acceleration will, however, occur in the Y-direction:

$$\ddot{Y} = K_1 (\dot{X}) - A_d - K_2 (Y) \quad (69)$$

Analysis shows the value of K_1 to be 2.22×10^{-3} and K_2 to be 1.39×10^{-6} . This latter parameter adds so little when the vertical displacement is less than 100 ft that it is neglected in this analysis. (When $Y = 72$ ft, $K_2(Y)$ is 10^{-4} ft/sec²). From equation (69), the displacement at $X=0$ will be:

$$Y = Y_c + \dot{Y}_o t - 1/2 [K_1(\dot{X})^2 - A_d] t^2 \quad (70)$$

Two substitutions, $t = X_c / \dot{X}$ and $Y_c = X_c \tan \theta$, will simplify this relationship:

$$Y_o = X_c \left[\tan \theta + \dot{Y}_o / \dot{X} \right] - 1/2 [K_1(\dot{X})^2 - A_d] \left(\frac{X_c}{\dot{X}} \right)^2 \quad (71)$$

It is of interest to know the miss distance under the worst practical circumstances. This, of course, requires a knowledge of which practical circumstances are the worst. Figs. 4-31 B thru F summarize the behavior of terminal error with respect to the independent variables. In all but two cases, terminal error behaves monotonically, thus permitting no practical maximum. In the cases of \dot{X} and X_c , however, the maximum in Y_o may be expected at particular values of the argument.

Consider first \dot{X} . The miss distance, Y_o , will have a maximum, for particular values of other parameters, where $\partial Y_o / \partial \dot{X}$ is zero.

$$\frac{\partial Y_o}{\partial \dot{X}} = \frac{X_c^2}{\dot{X}^3} A_d - \left[\frac{X_c \dot{Y}_o}{\dot{X}^2} + 1/2 \frac{X_c K_1}{\dot{X}^2} \right] \quad (72)$$

$$\text{At } \frac{\partial Y_o}{\partial \dot{X}} = 0, \quad \dot{X} = \frac{A_d X_c}{6 \left[\dot{Y}_o + 1/2 K_1 \right]}$$

Neglecting $1/2 K_1$, with respect to \dot{Y}_o ,

$$\dot{X} = \frac{A_d X_c}{6 \dot{Y}_o} \quad (73)$$

This miss distance may be maximized with X_c by a similar process.

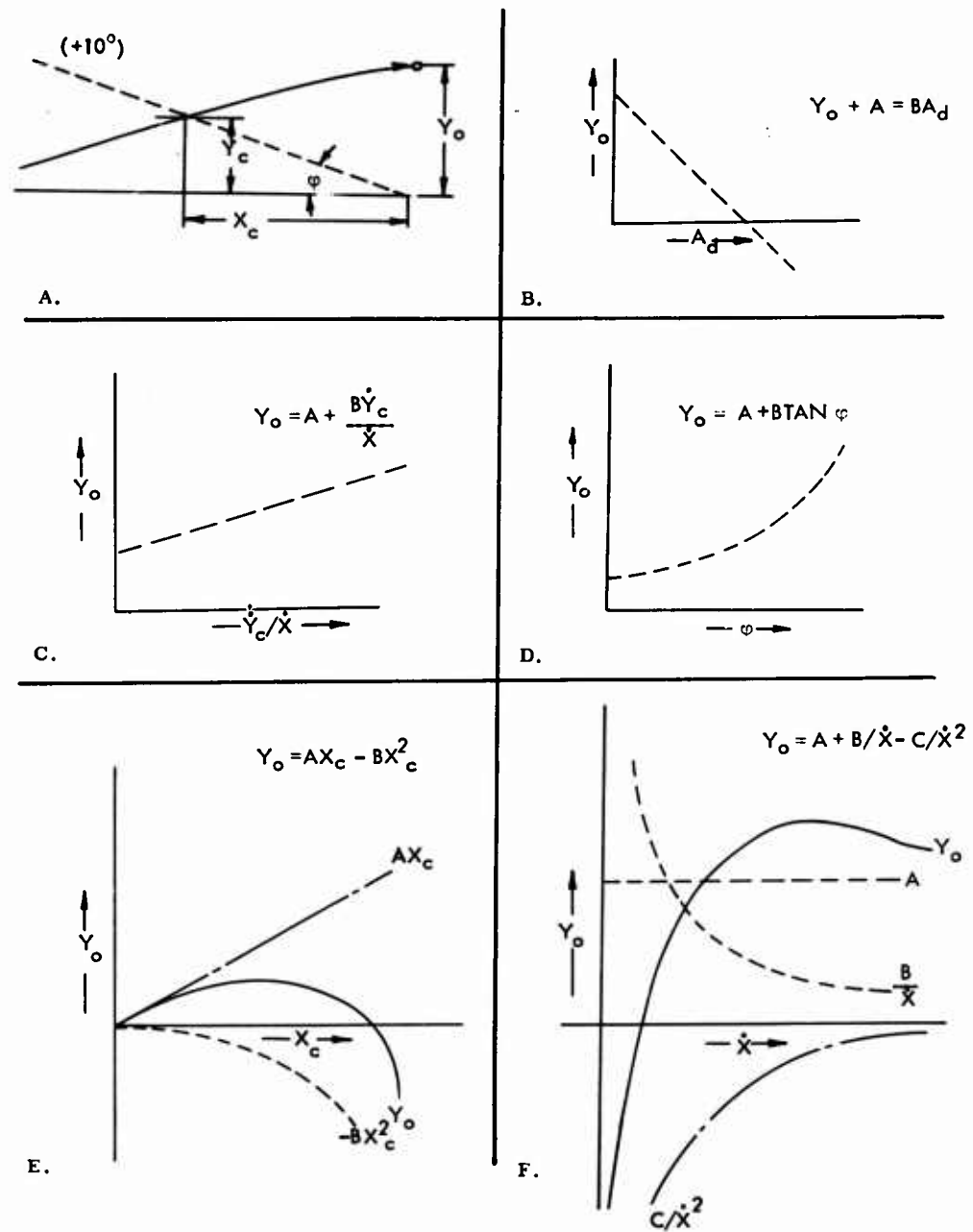

FIG. 4-31 SCHEMATIC OF TERMINAL RENDEZVOUS SITUATION AND BEHAVIOR OF ERRORS WITH RESPECT TO INDEPENDENT VARIABLES

$$\frac{\partial Y_o}{\partial X_c} \tan \phi + \frac{\dot{Y}_o}{\dot{X}} + 1/2 \frac{2X_c}{\dot{X}^2} [K_1 (\dot{X}) - A_d] \quad (74)$$

$$\text{At } \frac{\partial Y_o}{\partial X_c} = 0, \quad X_c = - \frac{\dot{X}^2 [\tan \phi + \dot{Y}_o / \dot{X}]}{[K_1 \dot{X} - A_d]} \quad (75)$$

From the foregoing process, two equations, equations (73) and (75) are available for maximizing Y_o with respect to both \dot{X} and X_c . By solving these equations simultaneously for \dot{X} and X_c , relationships are produced which will give the value of these parameters which simultaneously maximize the miss distance. The equations thus developed are:

$$\dot{X} = \frac{7A_d Y_o}{6Y_o K_1 - A_d \tan \phi} \quad (76)$$

$$X_c = \frac{42 Y_o^2}{6 Y_o K_1 - A_d \tan \phi} \quad (77)$$

In order to find the values of X_c and \dot{X} under practical circumstances, we consider the case in which:

$$\begin{aligned} \phi &= 15^\circ \\ A_d &= 25 \text{ fps}^2 \\ Y_o &= 20 \text{ fps} \end{aligned}$$

By applying equations (76) and (77),

$$\begin{aligned} \dot{X} &= 522 \text{ fps} \\ X_c &= 2600 \text{ ft} \end{aligned}$$

It is evident that the absolute maximum miss distance requires an impractical closing rate. Thus, in order to study the practical behavior of miss distance, reasonable values of X will be arbitrarily selected.

In order to study the influence of independent variables on the maximum miss distance, Y_o was computed from equation(71) for 18 cases of \dot{X} , \dot{Y}_o , and A_d :

$$A_d = 2.5, 5.0 \text{ fps}^2$$
$$\dot{X} = 10, 25, 50 \text{ fps}$$
$$\dot{Y}_o = 5, 10, 20 \text{ fps}$$

In each case, the value of X_c used was computed from equation (75). The results of this computation are tabulated in Table 4-5 and presented graphically in Figs. 4-32 through 4-35.

4.6.4.8 Compromise of Performance Factors

The following conclusions may be drawn from the results of the foregoing analysis:

- Terminal error increases with \dot{X}
- Terminal error increases with \dot{Y}
- Terminal error decreases with increasing A_d
- X_c increases with \dot{X} and \dot{Y}_o
- X_c decreases with increasing A_d

With the SMU method, terminal error (Y_o) is traded for cost (ΔV) and transit time. By adjusting A_d , a particular compromise among these three performance parameters may be effected. However, once a value of A_d is selected, a decrease in Y_o and/or ΔV , increases transit time.

4.6.5 Variations of the SMU Guidance Technique

From the foregoing analysis of the SMU guidance technique it is concluded that with minor modifications, the technique is practical for shuttle application. Since the shuttle is capable of carrying guidance instrumentation which the self maneuvering unit cannot, an investigation is required to determine how such instrumentation may be exploited to reduce energy expenditure and assist in maneuvering. Four variations of the SMU guidance technique are derived and

Table 4-5
 INFLUENCE OF A_d , \dot{X} , AND Y_o ON INTERCEPT
 DISTANCE AND MISS DISTANCE

A_d (ft/sec ²)	\dot{X} (ft/sec)	Y_o (ft/sec)	X_c (feet)	Y_o (feet)
2.5	10	5	30.9	11.9
		10	51.0	29.3
		20	108	103
	25	5	120	30.4
		10	172	51.5
		20	274	159
	50	5	388	72.1
		10	492	116
		20	702	231
5.0	10	5	15.4	5.9
		10	25.5	16.2
		20	45.5	52.0
	25	5	59.2	13.7
		10	84.6	28.6
			135	74.0
	50	5	184	35.7
		10	235	57.7
		20	334	117

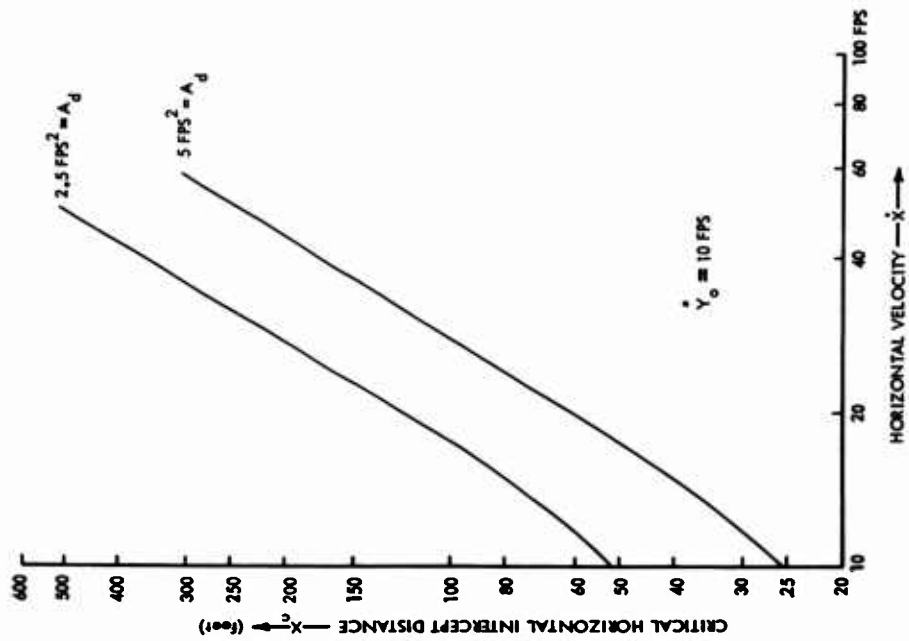

FIG. 4-32 INFLUENCE OF CORRECTION ACCELERATION ON X_c

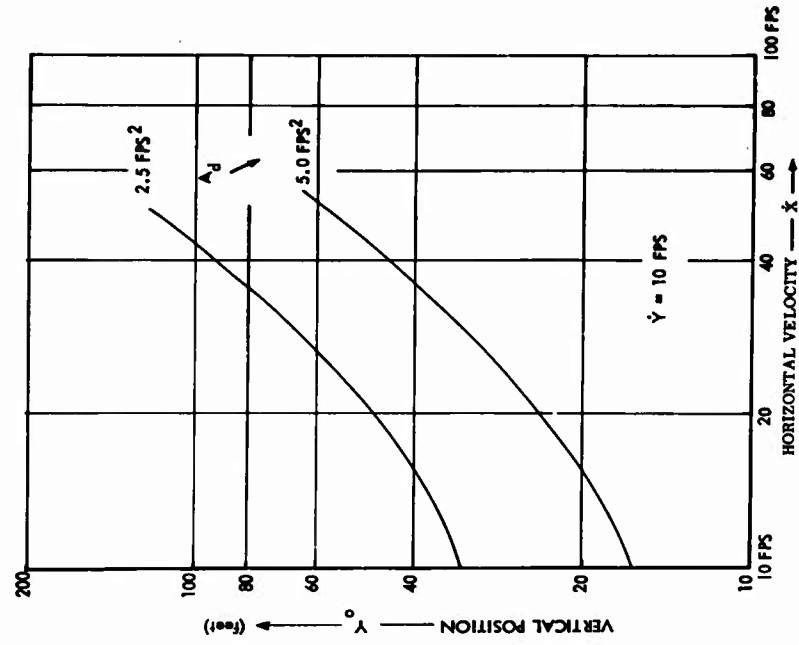

FIG. 4-33 INFLUENCE OF CORRECTIVE ACCELERATION OF MISS DISTANCE Y_0

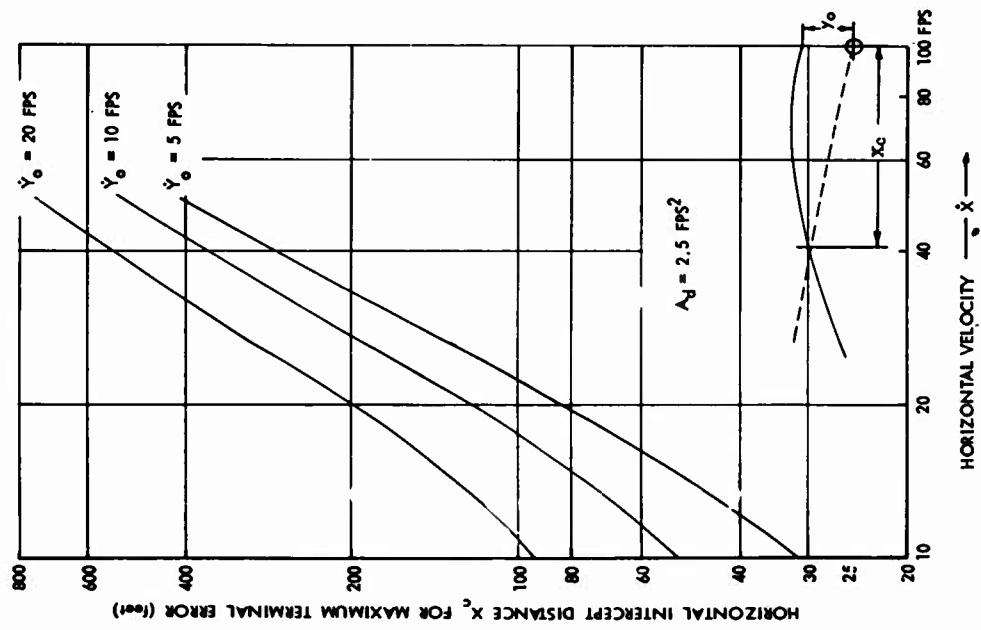

FIG. 4-34 INFLUENCE OF VERTICAL VELOCITY ON X_c

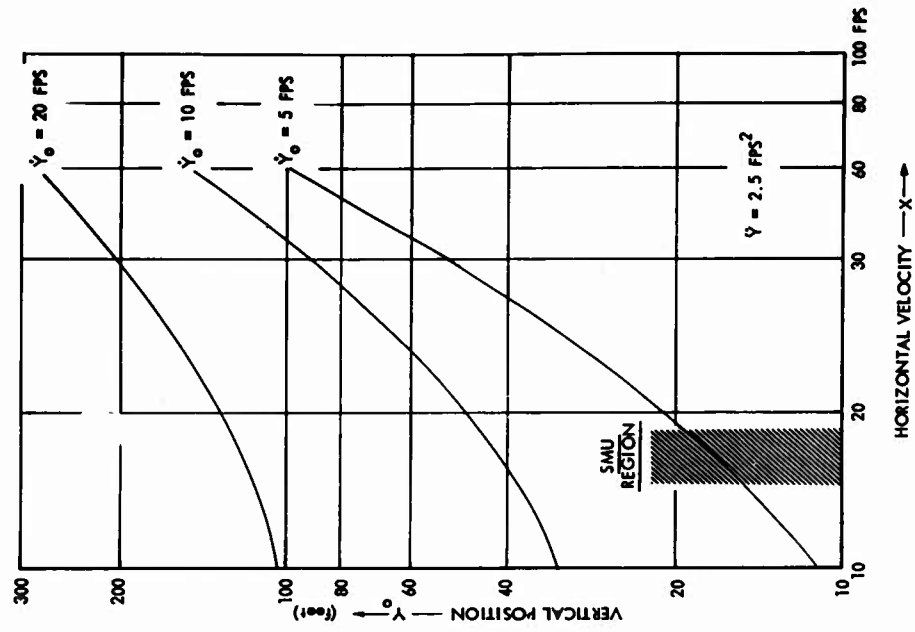

FIG. 4-35 INFLUENCE OF VERTICAL VELOCITY ON MISS DISTANCE

compared below for their relative merits. A plot of the resulting flight profiles is developed which serves to compare the energy expenditure requirements of each technique, and verifies that each solution is convergent. Further, it demonstrates that with a simple visual reference the maneuvering problem is eased considerably and the terminal errors become insignificant.

4.6.5.1 Corrective Thrust Criteria

Before variations of the SMU guidance techniques can be derived, it is necessary to determine the sensitivity of the flight path to the magnitude and duration of corrective thrust.

Fig. 4-36 shows the flight path which results when the shuttle begins from 30,000 feet on a flight path directed horizontally toward the target. It is assumed that the target is in a circular 300 n.mi orbit, and the shuttle is attempting an intercept along a horizon line with a closing rate of 25 fps. Because the flight path is horizontal, and the velocity is supercircular ($V_c + 25$ fps), the starting point represents the perigee of the shuttle's elliptical flight path. As it closes toward the target, the shuttle climbs in altitude until, at a range of about 20,600 ft, the target exceeds a 10 deg depression angle, and the condition prevails which requires a correction maneuver.

The sensitivity of the transfer trajectory to the correction criteria is illustrated in Fig. 4-36. Here, three criteria were used to shut off the \overline{T}_d impulse. In one case the impulse ended at $\dot{\epsilon} = 0$. (When the target's angular rate goes through zero). In the second case, it is ended 1 sec after $\dot{\epsilon} = 0$. This was the criterion used by Chance-Vought in their study. The third criterion derives from the apparent rate of the stars in the celestial sphere; 1.16 milliradians per sec. Since angular rate is judged by motion of the target relative to the stellar background, it is reasonable to investigate the condition where the end of the impulse depends upon the target's having an angular rate which exceeds that of the celestial sphere. Hence, the criterion for the third case is $\dot{\epsilon} = 1.16$ milliradians plus 0.5 sec (thrust reaction time).

CLOSING RATE = 25 FPS
 $A_d = 15 \text{ FPS}^2$

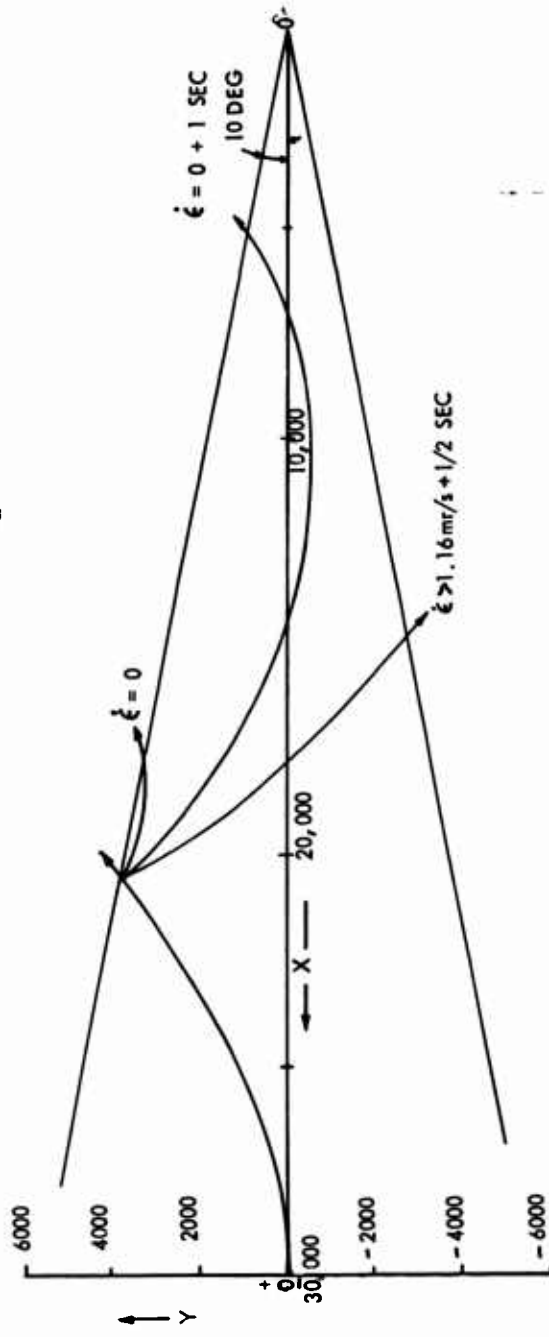

FIG. 4-36 TYPICAL SMU TRAJECTORIES

The sensitivity of flight path to these three criteria for thrust termination is illustrated in Fig. 4-36. If the pilot can consistently anticipate $\dot{\epsilon} = 0$ enough to compensate for reaction time, the resulting flight path will skim along under the +10 deg line leading to the target. If he has difficulty in detecting $\dot{\epsilon} = 0$, and has to terminate thrust at $\dot{\epsilon} = 1.16 \text{ mr/sec} + 0.5 \text{ sec}$, the pilot will find that he has to frequently apply thrusts in opposite directions. It is interesting to note that the $\dot{\epsilon} = 0 + 1 \text{ sec}$ criterion reported in ASD-TDR 62-278 is nearly optimum. It carries him from 20,600 ft to about 5040 ft before a subsequent impulse is required. It is evident that a wide range of flight paths will result from relatively small variations in the criterion used to terminate the correction thrust.

4.6.5.2 Alternate Guidance Techniques

Four guidance techniques, which are variations of the SMU scheme, are developed and studied to determine their relative economy and maneuvering ease.

Of particular interest is the behavior of the flight path in the terminal phase as rendezvous is approached. To illustrate this, four flight paths are constructed using $\dot{\epsilon} = 0 + 1 \text{ sec}$ as thrust correction criteria which Fig. 4-37 indicates to be the near-optimum solution. Each of the paths commence at the same arbitrary point on the +10 deg limit cycle with the shuttle's horizontal velocity being 25 fps. From this point, the guidance mode for the four conditions is depicted in Fig. 4-37. The criteria used is given as follows:

Condition I - Using a visual tracking reference the shuttle is maintained within an exact limit cycle of $\pm 10 \text{ deg}$ using a corrective impulse of 15 fps^2 .

Condition II - Using a visual tracking reference the shuttle is maintained within an exact limit cycle of $\pm 10 \text{ deg}$ using a corrective impulse of 3 fps^2 .

Condition III - With no visual tracking reference the shuttle is maintained within a limit cycle modified to account for random components of control commands. This is typical of the tracking accuracy that can be achieved without tracking aids. The angle (ϵ) at which the corrective impulse is initiated is

normally distributed with a mean of 15 deg and a standard deviation of ± 3 deg. The corrective impulse termination is also normally distributed. It occurs 0.5 sec after the target's angular rate goes to a value randomly determined by a normal distribution which has a mean of 1 mrad/sec and a deviation of 0.5 mrad/sec.

Condition IV - Using a visual reference, the pilot attempts to null the angular displacement to zero in lieu of trying to maintain the shuttle within a given limit cycle. Incrementally variable acceleration levels are used, although this provision is not essential to the utility of the method.

4.6.5.3 Comparison of Guidance Modes

Figure 4-37 shows the resultant flight paths for the conditions cited above. There are two basic conclusions that can be drawn from inspection of the different conditions. One is that high corrective thrust levels are expensive in energy expenditure. The other is that a larger terminal position error occurs at lower thrust levels.

Condition I is estimated to require as much as 10 times the ΔV that condition II does. It also appears that a repeatable maneuvering criterion is not extremely important to fuel economy since Condition III requires about the same ΔV as Condition I for the same acceleration levels.

It should be noted that Condition IV is considerably better than the others from the standpoint of miss distance and energy expenditure. With the aid of a visual reference, the pilot is able to null small angular errors early and keep the shuttle from drifting to large terminal errors. In comparing ΔV expenditures for the four conditions, Condition II appears to be comparable to Condition IV. However, it must be emphasized that the flight path for Condition II is probably not typical of trajectories within a 3 fps^2 thrust regime and the seemingly small terminal error may be regarded as coincidentally fortuitous. Many conditions could arise with low acceleration levels where the shuttle would exceed the limit cycle and the thrust level would be inadequate to effect sufficient correction before contact, resulting in large terminal errors.

4.6.5.4 Economic Advantages of a Reference System

In deciding on the economic advantages of a system using a visual reference scheme, one must weigh the investment in instrument weight vs the weight of fuel required to accommodate an absence of the instrument.

The velocity increment produced by a pound of fuel is related to the specific impulse by:

$$\Delta V = \frac{I_{sp} g}{W} \quad (78)$$

For a typical shuttle configuration, $I_{sp} = 285 \text{ lb sec/lb}$, $g = 32.2 \text{ ft/sec}^2$, and $W = 1250 \text{ lb}$. From this, the trade-off of fuel weight vs. equipment weight may be expressed as:

$$7.32 \text{ fps of } \Delta V = 1 \text{ lb of fuel}$$

Thus, if by adding a 10 pound instrument, a flight path results which saves more than 74 fps of ΔV , as compared to the equivalent flight path in the instrument's absence, a net economy results. Since the proposed visual reference equipment could be made very light (2 - 5 pounds), it appears that under the worst conditions, a reference unit constitutes a weight advantage. (Under many circumstances, the resulting system will be substantially lighter if the reference instrument is used.)

As a final observation on the economy of this technique, consider the case in which, by successive corrections, the horizontal flight path is finally achieved, and it is of interest to maintain this by applying rocket thrust to compensate for radial orbital forces. The acceleration required for orbit maintenance has been found to be:

$$A_M = .00222 \dot{X}^2 \text{ ft/sec}$$

where \dot{X} is the closure rate, in fps. At a rate \dot{X} , the time required to close on a target at a distance D is:

$$t = D/\dot{X} \quad (79)$$

The velocity increment during this closure will be the product of acceleration and time.

$$V = 0.00222 \dot{X} \quad D/\dot{X} = 0.00222 D \text{ fps} \quad (80)$$

or

$$V = 11.65 \text{ fps/mi}$$

The energies which result from this method may be compared to those of comparable SMU cases in Table 4-6.

Table 4-6

**ENERGY COMPARISONS OF GUIDANCE TECHNIQUES
USING A VISUAL TRACKING REFERENCE**

Initial Range	\dot{X}	ΔV	
		SMU	Const. Thrust
1,000 ft	15 fps	32 fps	2.22 fps
5,000 ft	15 fps	41 fps	11.1 fps
15,000 ft	16 fps	68 fps	33.3 fps
30,000 ft	18 fps	127 fps	66.6 fps

The economic advantage of a reference unit is evident from the lower values of ΔV . The constant thrust maneuver may be considered to represent the best that can be expected, using the technique of Condition IV and hence, the figures tabulated represent the ideal minimum energy which is required.

4.6.6 A Communication Scheme for a Back-Up Guidance Mode

An investigation is made below to determine the feasibility of the primary vehicle to guide the shuttle by means of target range data transmitted from the primary to the shuttle via a communication link. Such a system has the advantage of placing the capital investment in equipment weight in the primary vehicle.

The geometry considered in this analysis for implementation of the idea is shown schematically in Fig. 4-38. In this figure, the primary is at P, the shuttle is at S, and the target at T. The shuttle has attained this position by dead reckoning from the primary vehicle to the vicinity

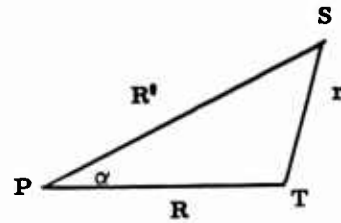

FIG. 4-38 GEOMETRY OF RENDEZVOUS SITUATION

of the target and is assumed to be in visual contact. A radar on the primary ship would be capable of measuring ranges R and R', and the angle α . Required is the target range, r, from the shuttle. Mathematically, this is found as

$$r^2 = R^2 + R'^2 - 2RR' \cos \alpha \quad (81)$$

Target Range Error - The error in estimating r may be found from errors in α , R, and R':

$$\epsilon_r^2 = \left(\frac{\partial r}{\partial R}\right)^2 \epsilon_R^2 + \left(\frac{\partial r}{\partial R'}\right)^2 \epsilon_{R'}^2 + \left(\frac{\partial r}{\partial \alpha}\right)^2 \epsilon_\alpha^2 \quad (82)$$

The weighting factors are evaluated as

$$\frac{\partial r}{\partial R} = \frac{R}{r} \left(1 - \frac{R'}{R} \cos \alpha\right)$$

$$\frac{\partial r}{\partial R'} = \frac{R'}{r} \left(1 - \frac{R}{R'} \cos \alpha\right)$$

$$\frac{\partial r}{\partial \alpha} = R \frac{R'}{r} \sin \alpha$$

For analytic convenience, it will be assumed that $R = R'$. For this case, the error equation becomes:

$$\epsilon_r^2 = 2 \left(\frac{R}{r}\right)^2 (1 - \cos \alpha)^2 \epsilon_R^2 + \left(\frac{R^2}{r}\right)^2 (\sin^2 \alpha) \epsilon_\alpha^2 \quad (83)$$

Magnitudes Considered - The evaluation of an error magnitude for target range requires the prescription of parameters representing the geometrical case to be considered. For the present analysis, a case, near the worst practical circumstances, will be considered: parent-shuttle range of 20 n. mi. Errors in parameters will be taken as:

$$\epsilon_R = 1\% \text{ of } R$$

$$\epsilon_\alpha = 1 \text{ mrad}$$

which are representative of the errors expected from a typical space station radar. The analysis is parameterized in increments of target range.

Analysis - By applying the foregoing magnitudes and errors to equations (81) and (82), values of r and ϵ_r may be found for a spectrum of values of α . Table 4-7 summarized these calculations for a primary to target distance of 20 n.mi.

TABLE 4-7

VALUES OF RANGE AND RANGE ERROR FOR VARIATIONS IN α

α (deg)	r (n. mi.)	$\partial r / \partial R$	$\partial r / \partial \alpha$	error due to R (ft)	error due to α (ft)	α (ft)
0.5	0.155	0.00448	107,000	4.76	107	107
1	0.300	0.0174	107,000	18.4	107	108
2	0.606	0.0180	107,000	19.1	107	108
3	0.910	0.0256	107,000	27.2	107	110
5	1.51	0.0437	107,000	46.5	107	117
7	2.12	0.0611	107,000	65.0	107	125
10	3.03	0.0882	107,000	93.7	107	142

Conclusion: These results are presented graphically in Figure 4-39. It appears from this study that as the shuttle closes on the target, the total uncertainty in range diminishes to a terminal value of about 100 feet at 1 mile range. As closure continues beyond this point, the bulk of the error is due to

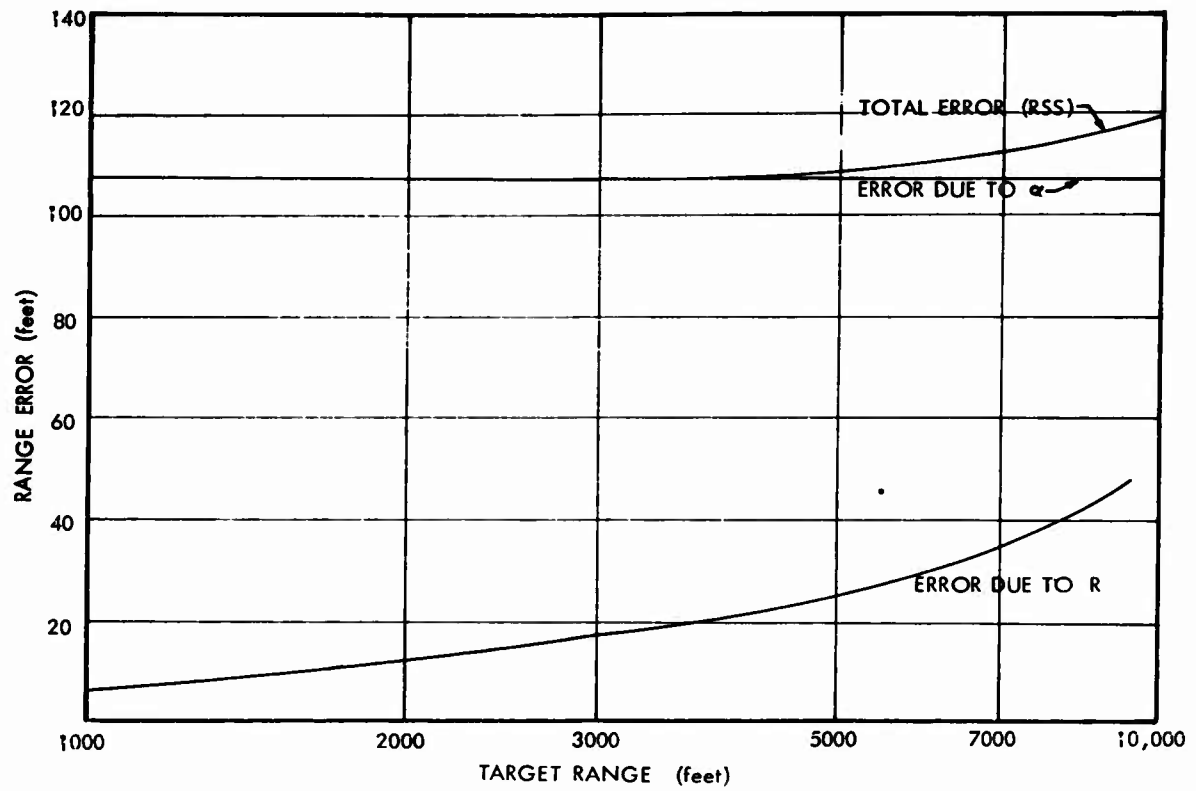

FIG. 4-39 SHUTTLE RANGE UNCERTAINTY DUE TO ERRORS IN PRIMARY VEHICLE RADAR MEASUREMENTS

the constant angular contribution, and a minimum range uncertainty of 100 ft will be present. However, from a 100 ft separation between shuttle and target, the pilot can observe aspect and closure rate to complete the maneuver. The conditions here are such that the target's shape and orientation are visible; and this information permits the pilot to control range and range rate by eye while orienting the shuttle for docking.

4.6.7 Conclusions and Recommendations

On the basis of the requirements and constraints established for shuttle operation, the foregoing analysis defines the characteristics of the Navigation and Guidance system. Following is a resume of the studies made and conclusions reached that provide a design basis for the guidance system.

The principal requirements and constraints imposed are that the shuttle:

- a. must have a 20 mile range capability
- b. must not rely on the targets being augmented
- c. must operate under orbital day and night conditions to perform all missions

An investigation made of target visibility under orbital conditions determined how adequately the pilot could perform his tracking task with unaugmented targets at ranges of 20 miles. Targets greater than 1 ft in diameter will be visible at 20 miles when illuminated by the Sun. Targets greater than 10 ft in diameter will be visible at 20 miles when illuminated by the Earth. In most cases, adequate target illumination and satisfactory contrast will exist for about an hour, followed by a period of about one-half hour of inadequate visibility. This assumes a nearly horizontal approach.

For routine missions, where time is not critical, the maneuver can be planned such that the pilot theoretically requires no tracking aids. However, where a mission situation dictates immediate response, and visibility conditions are inadequate, pilot vision must be supplemented by artificial illumination of the target. Since it is desirable to have a standard shuttle capable of performing all missions, it is recommended that tracking aids be included in all shuttles.

To further substantiate their use, the human factors studies reported in ASD TDR 278, indicate there is considerable doubt as to the pilots' ability to adequately perform his tracking task, even under good visibility conditions. Of particular concern is his ability to judge distance and closure rate accurately enough to perform a safe docking maneuver. Further studies show that it is possible to more than reclaim the tracking equipment weight in fuel saved with the added advantage of reducing terminal errors.

Tracking of unaugmented targets restricts the types of tracking systems that can be efficiently employed. Infrared systems for non-cooperative targets are considered impractical. The acquisition problem is severe because of temperature variations and they provide no ranging information. Laser systems, in their current state of development, are bulky, inefficient, and demonstrate no capability exceeding known microwave techniques. There is also the possibility of physiological damage resulting from the high power density of the transmitted beam. In view of the deficiencies of these systems, radar appears to be the most practical tracking aid for the shuttle.

There are practical limits to the size of radar that the shuttle can accommodate. Therefore, the size of the radar should be based on the navigation techniques employed. For example, a radar required for the shuttle to track an unaugmented target at 20 miles would weigh about 65 lb and require a 60 inch diameter parabolic antenna. Whereas, a radar for tracking a target at 6 miles would weigh only about 20 lb, with a 20 inch diameter antenna. An investigation of the adaptability of the SMU guidance technique to the shuttle indicates that it is a practical and stable method for ranges of 6 miles or less. However, with greater initial ranges the method uses excessive propellant and creates rather large terminal errors. In determining how accurately the primary vehicle and target orbits can be matched, studies show that 6 miles is quite representative of the ranges involved in shuttle operations. Greater distances are involved only when the terminal dispersions are permitted to magnify with time. These considerations indicate that 6 miles is a practical design objective for the radar to keep its size within reasonable limits. Where extended ranges are involved,

alternate guidance techniques can be employed. Although the radar can only detect passive targets at 6 miles, continuous surveillance of the primary vehicle can be maintained by use of a simple transponder. Thus, if mission recall or abort becomes necessary, the primary vehicle is always under surveillance of the shuttle radar. In the event of radar failure, the two-way communication system is adequate for a backup guidance mode. A flashing beacon on the primary vehicle would permit visual tracking in this mode.

At ranges exceeding 6 miles, it is not practical to employ the SMU guidance technique, even with appropriate tracking aids. The distances subtended by the angle which establishes the limit cycle are extremely large and would require large velocity increments to reduce transit time to reasonable values. Large closing velocities give rise to large terminal errors and impose severe acceleration requirements on the control system. In view of these requirements, open loop guidance techniques are recommended for extended range applications. This technique can readily be employed by the primary vehicle computing the shuttles' thrust vector for target interception. The shuttle proceeds in the direction computed with the applied thrust set by a timer. As the target is acquired, either visually or by radar, a braking maneuver is begun to reduce the closing velocity and the guidance mode is changed to the SMU technique.

It is further recommended that the SMU guidance technique for shuttle application be modified to conform to the flight profile shown as Condition IV in Section 4.6.5 and depicted in Figure 4-37. This can readily be accomplished by use of the radar or a visual reference reticle. The advantages of this modification are manifest in a comparison of the basic SMU technique with the modified technique using instrumentation. From a 20 mile starting range, terminal position errors are reduced from 100 feet to 20 feet and terminal velocity errors from 20 fps to 5 fps. The resultant savings in propellant is about 20 lbs taking into account a 5 lb instrument investment for the visual reference. Since the radar weighs only 20 lb, the weight investment is paid for in a one-way trip. In summary, the guidance system, recommended for the shuttle consists of a 6 mile radar with range and range rate displays and a

cross-hair type angular reference indicator. For visual reference, a reticle is suggested which is representative of the radar angular reference indicator. The guidance technique recommended is open loop navigation for ranges extending beyond 6 miles, and the modified SMU method for terminal maneuvers.

Section 5

HUMAN FACTORS

The shuttle vehicle is intended to aid man to live and accomplish useful work in the space environment. This section discusses the life support requirements, and the man-vehicle relationship necessary for the crewman to make decisions and take the appropriate action. Life support requirements are well known from previous work, and this report discusses only the factors pertinent to the shuttle situation. The principles guiding the man-vehicle relationship adopted for the shuttle are discussed in Section 5.2. The relationship of man to the task to be performed is a new area in which there has been no direct experience. The major effort in the study of human factors was, therefore, the performance of simulated maintenance tasks by a subject in a pressure suit. The experiments performed and the resulting conclusions are presented in Section 5.3. From data on the shuttle-to-crew task analysis, and the maintenance task analysis, an evaluation of a single crewman's ability to perform the shuttle mission is made in Section 5.4.

5.1 LIFE SUPPORT

The composition and pressure of the atmosphere provided in the shuttle is the major consideration of the life support system. As it is expected that the crewman will find it necessary to occasionally depressurize the vehicle, either to perform the tasks demanded of him or for egress or ingress to the shuttle, an atmosphere that facilitates the transition from pressure cabin to pressure suit operation is necessary. Such provision is also demanded by the possibility of accidental decompression from collision or meteoroid damage. Both of these considerations lead to a choice of pure oxygen at a nominal pressure of 5 psi to avoid the need for pre-breathing and to avoid excessive pressure drops upon the transition from cabin to suit pressure.

The nominal mission time of five hours with a maximum of ten hours for emergencies is so short that no special requirements for food or water are necessary, although stowage space is provided for small amounts of these items.

Similarly, no special waste disposal provisions are made for this short mission. It is assumed that the space suit is worn continuously and that its provisions are adequate.

A consideration of nuclear radiation or radiation from solar flares is excluded from this study. It is assumed that shuttle missions will not be undertaken under such conditions and that adequate protection will be provided on the primary vehicle.

5.2 SHUTTLE - CREW INTEGRATION

Three types of activity are considered for the crewman to operate the shuttle: (1) control of the vehicle trajectory, (2) conduct of the docking, alighting and cargo pick-up operation with grapplers, and (3) monitoring and control of the shuttle subsystems. The crewman is used as an element in the system to perform functions of sensor, computer, and servo, and to make required decisions.

As it is necessary to supplement the pilot's visual abilities with radar, the radar display is integrated with the visual display afforded by the large windows enabling the crewman to function in the same manner with either source of information.

The functions of interpreting the data received and initiating the proper actions for control of the trajectory and the docking maneuvers are performed by the pilot. The only computer installed in the shuttle is the thruster selection circuitry of the attitude control system. The pilot performs a similar function in completing the feedback control system of the grapplers in that he

visually observes the position of the grippers and operates the controls to produce the desired motion.

The pilot governs the conduct of the mission and the choice of alternate modes of operation of the shuttle. Switching from one mode to another is a manual operation.

The arrangement of the cockpit, controls, and instruments to implement the philosophy described above is described in Section 6.

5.3 MAINTENANCE AND REPAIR TASK ANALYSIS

The major repair and maintenance requirements in space have been identified in Ref. 3-3 and the elements of each task have been examined in detail in Refs. 3-3 and 1-1. These reports study the ability of the worker to perform specific operations in the space environment (with particular emphasis on the effects of weightlessness), but little data is available on the ability of a worker to perform complete tasks when encountering the problems of accessibility in complete systems compounded by the hindrance of a space suit. Experiments were conducted in this study using mock-ups of typical space equipment and evaluating the effects of several operational techniques, as well as the effects of several variants in shuttle geometry. This work is reported in para. 5.3.1.

In para. 5.3.2, the data obtained in the task simulation test is used together with published data on manipulators to evaluate the several maintenance techniques considered.

A summary of the conclusions and their implications for shuttle design is presented in para. 5.3.3.

5.3.1 Maintenance Task Simulation Test Program

An evaluation of the human factors problems encountered in performing typical space maintenance tasks was obtained by a subject in a Mark 4 pressure suit attempting typical tasks selected from Ref. 3-3. A wooden mock-up simulating a portion of the Agena engine, engine mount, and aft rack assembly, was used as one problem in maintenance. A wooden mock-up of a fuel cell of the general proportions considered by the Contractor for the Apollo service module served as the replacement task problem. A switch box to be replaced was also incorporated. A typical double-skin shell structure was used for the puncture repair task. The operator performed each of these tasks in an unpressurized suit with a simulated shuttle hatch in each of two positions, repeated with the suit pressurized, and again with a simulated sleeve arrangement of the shuttle vehicle.

To perform this program in the time and budget available, the sleeve technique was simulated by using the pressurized Mark 4 suit and suitable arm holes and fabric cuffs in the forward face of the vehicle. Although this is not an ideal sleeve arrangement, it is believed that the differences between this and a proper sleeve set-up are small compared to the differences observed between operating with sleeves and with a pressurized suit unhampered. Figures 5-1 through 5-16 illustrate the equipment used, the modifications made to the tools to facilitate their use with a pressurized suit, and the important difficulties encountered during performance. The time required to perform each operation is recorded in Tables 5-1 through 5-4. Elapsed times (Σ) were measured, and time increments (Δ) were calculated; all time is in minutes. Items with * were combined with other tasks so that separate time increments are not shown. The major conclusions concerning the relative advantages of the sleeve technique and the tool modifications found desirable are summarized below.

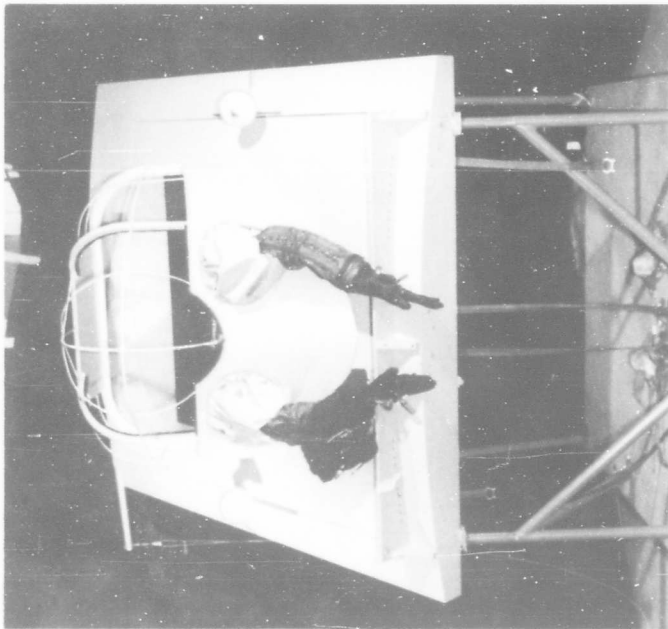

FIG. 5-1 SIMULATED SLEEVE VEHICLE CONFIGURATION

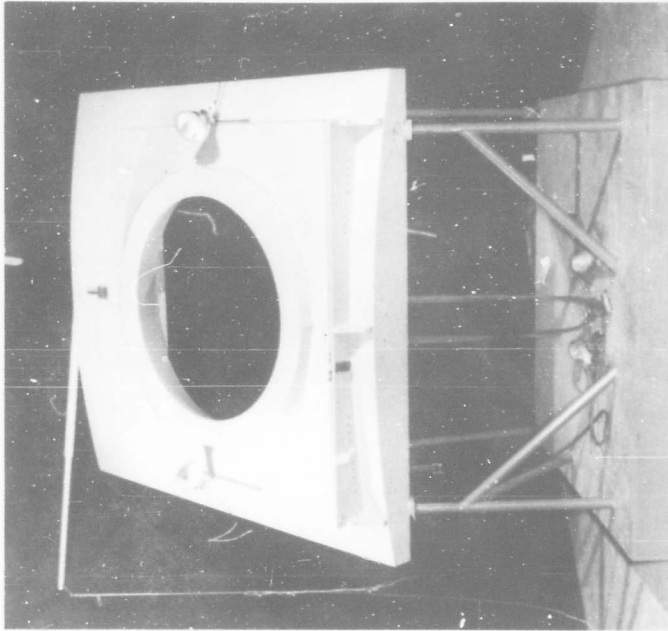

FIG. 5-2 OPEN HATCH VEHICLE 45 DEGREE CONFIGURATION

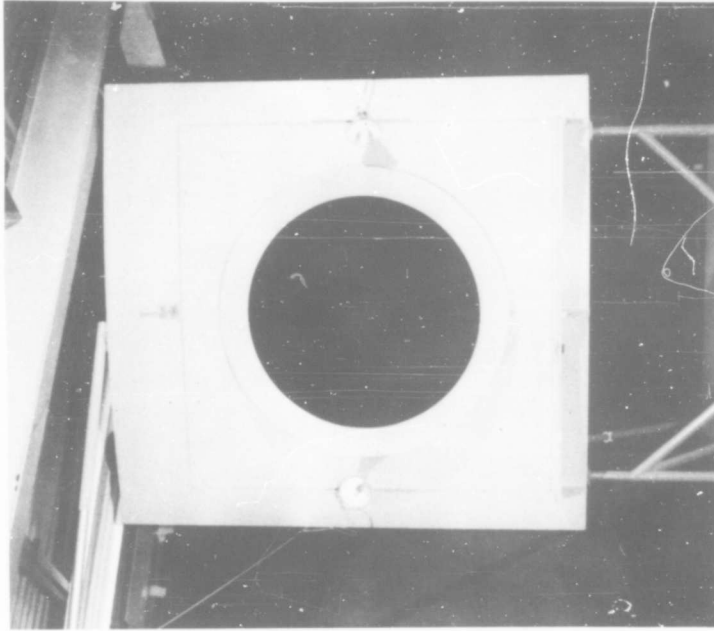

FIG. 5-4 OPEN HATCH VEHICLE CONFIGURATION
VERTICAL

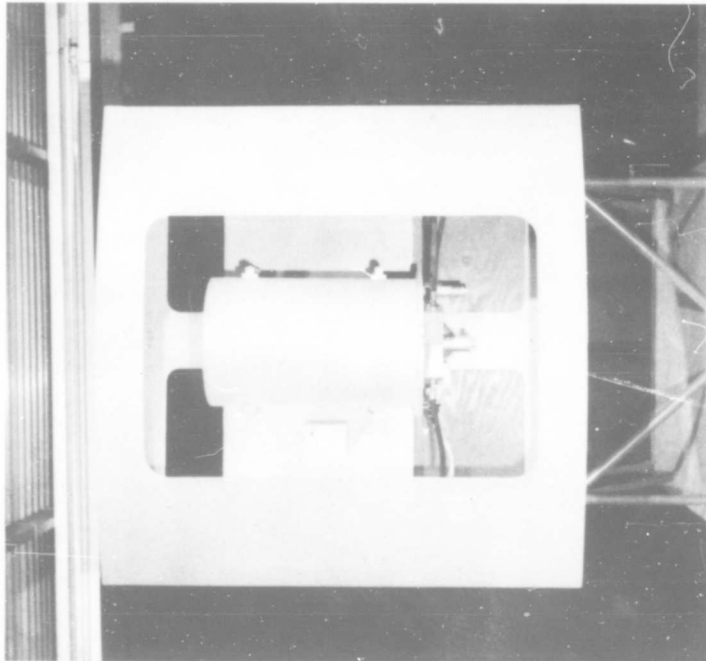

FIG. 5-3 FUEL CELL REPLACEMENT AND SWITCH
REPLACEMENT PROBLEM

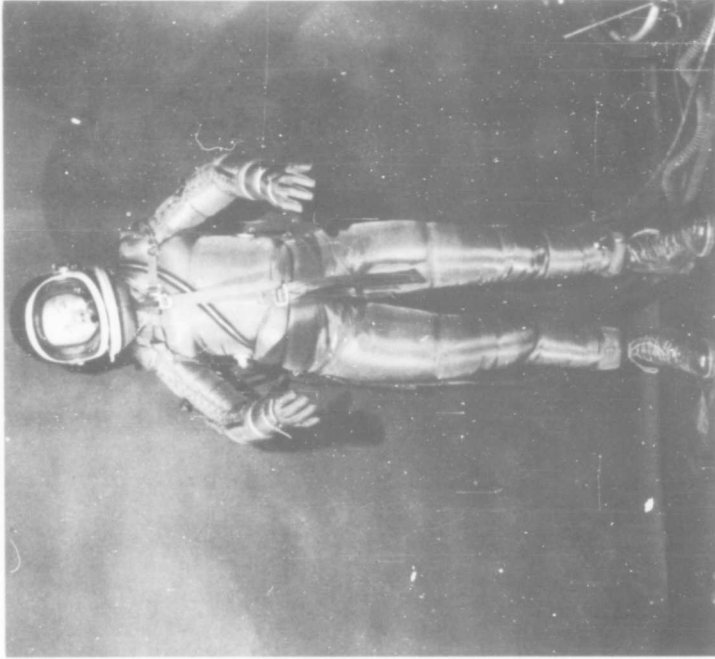

FIG. 5-6 PRESSURIZED MARK 4 SUIT

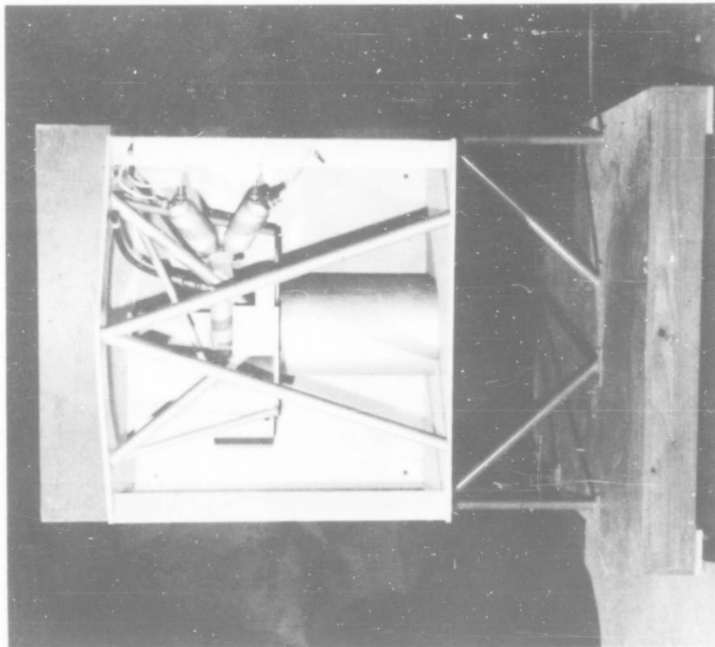

FIG. 5-5 ENGINE IGNITER GASKET REPLACEMENT PROBLEM

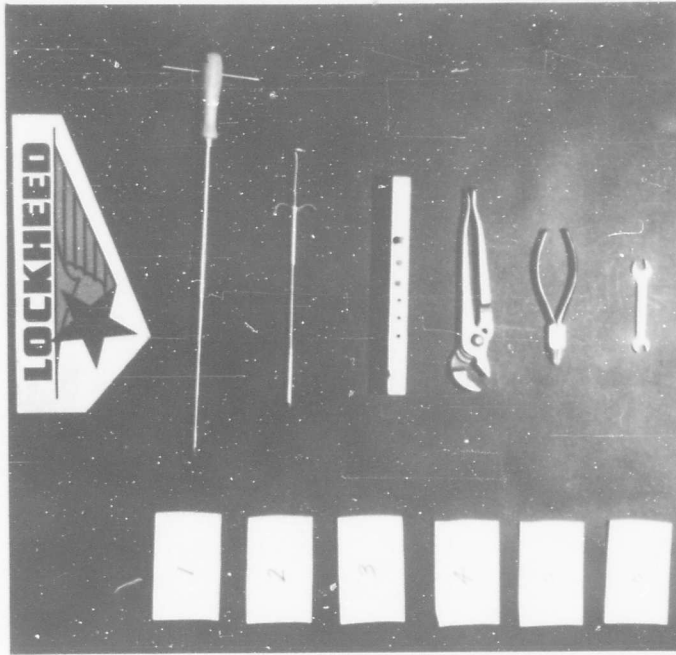

FIG. 5-8 TOOLS FOR SWITCH REPLACEMENT

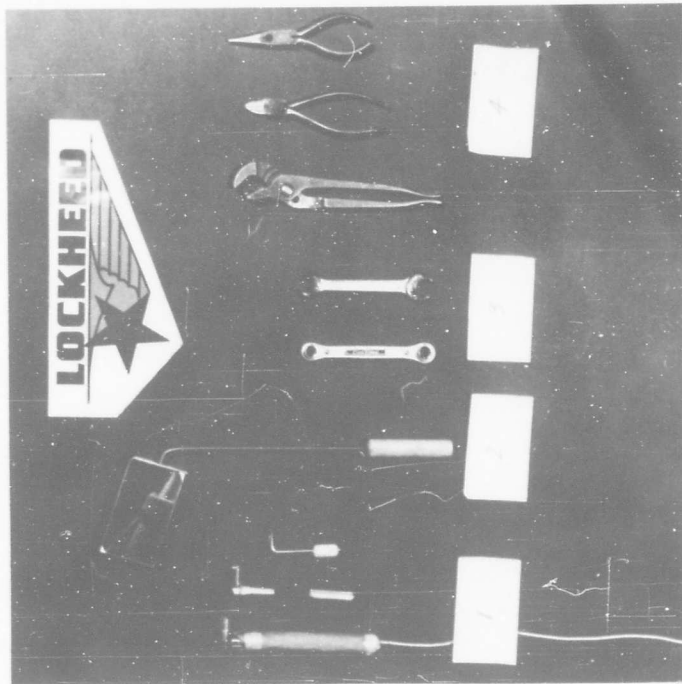

FIG. 5-7 TOOLS FOR ENGINE IGNITER GASKET REPLACEMENT

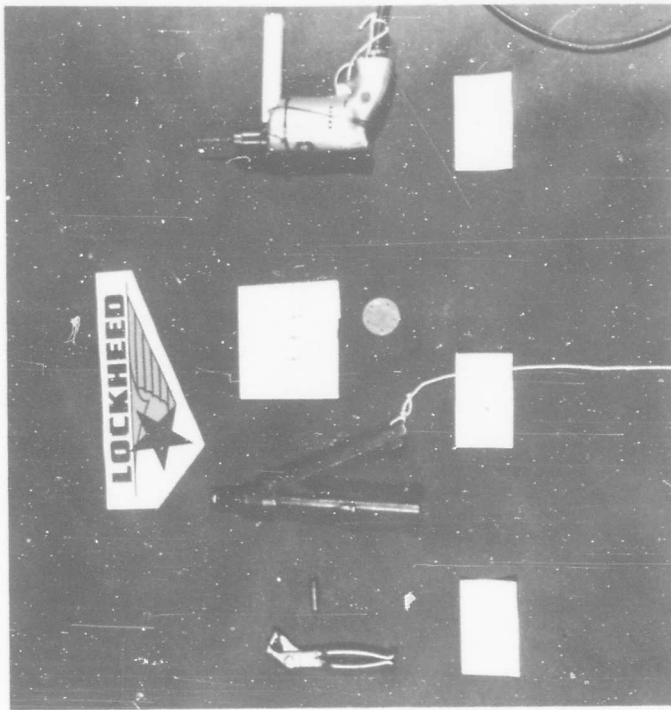

FIG. 5-10 TOOLS FOR PUNCTURE REPAIR

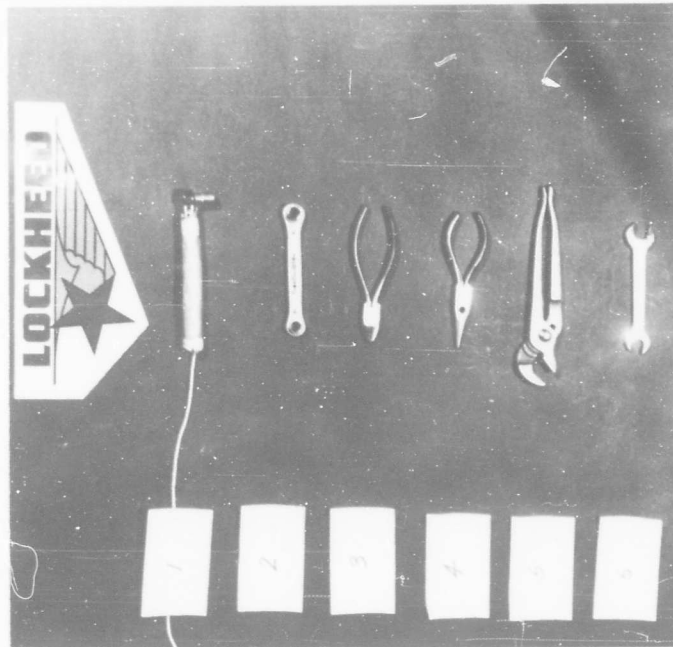

FIG. 5-9 TOOLS FOR FUEL CELL REPLACEMENT

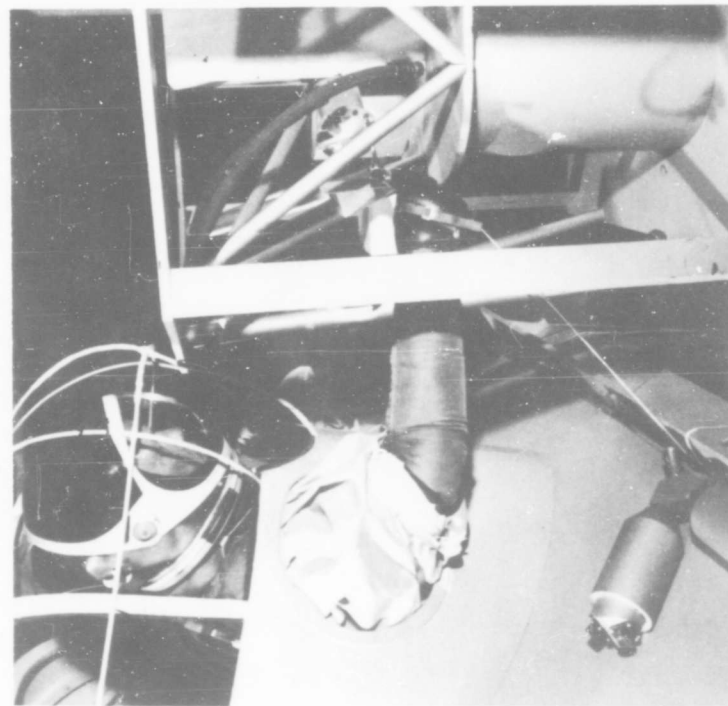

FIG. 5-11 ACCESS TO IGNITER WITH SLEEVES

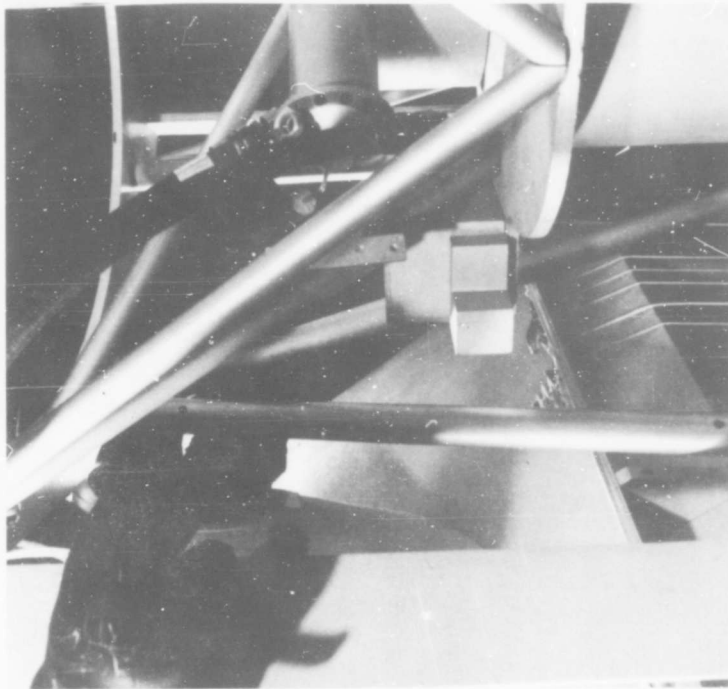

FIG. 5-12 SLEEVES - GASKET REPLACEMENT - P. SUIT REMOVING ALLEN HEAD BOLTS FROM TOP OF GAS GENERATOR INJECTOR. AGENA ENGINE, USING ALLEN WRENCH WITH 6" HANDLE ADDED TO ALLEN WRENCH. NOT ABLE TO TURN BOLTS.

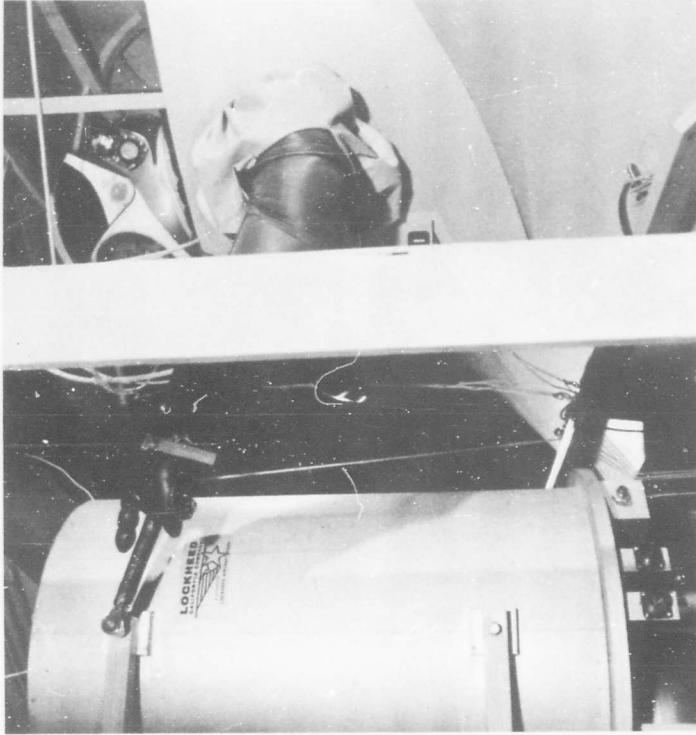

FIG. 5-14 ACCESS TO FUEL CELL MOUNTING BOLTS WITH SLEEVES

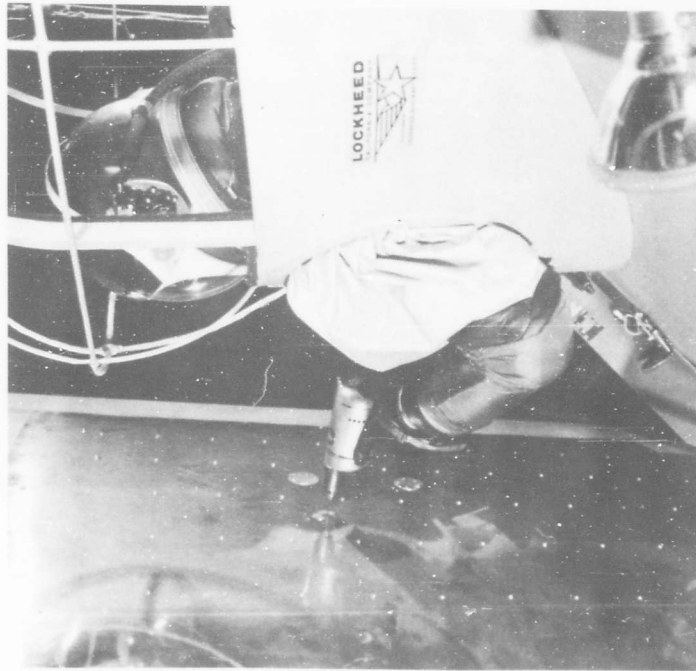

FIG. 5-13 USE OF DRILL WITH SLEEVES

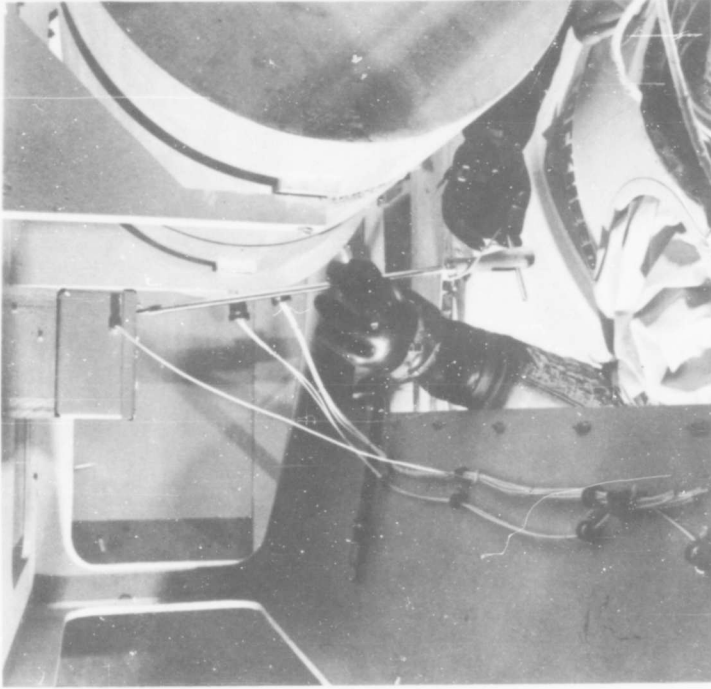

FIG. 5-16 MODIFIED SCREW DRIVER FOR SWITCH REPLACEMENT

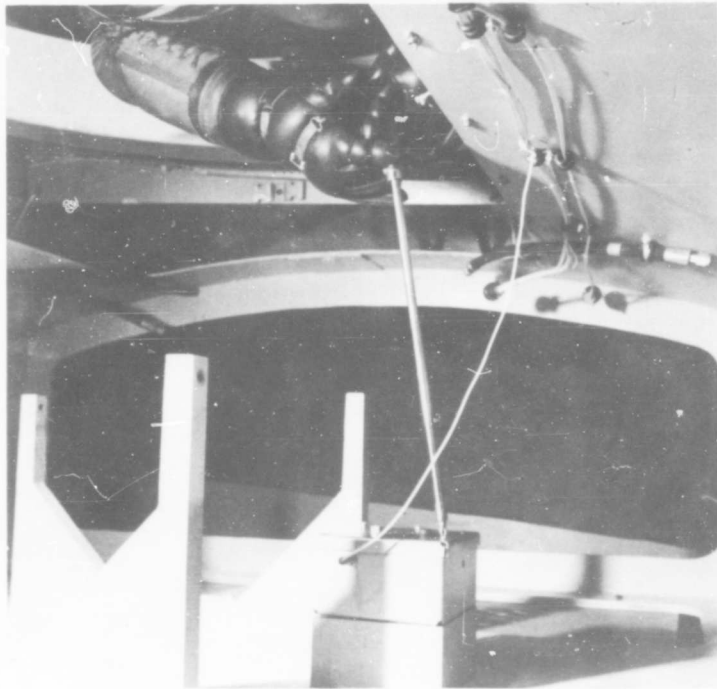

FIG. 5-15 USE OF LONG SCREW DRIVER FOR SWITCH REPLACEMENT

Table 5-1
MAINTENANCE TASK SIMULATION
 (Time in Minutes)
Replace Gasket on Starter Generator

Task Requirements	CONTROL CONDITION			SHUTTLE/PRESSURIZED SUIT			
	Δ	Shirt Sleeve Σ	Unpres. Suit Σ	Δ	Sleeves Σ	Hatch 90 deg Σ	Hatch 45 deg Σ
1. Secure solid charge igniters by cutting lock-wire and separating electrical connectors. There are two igniters per start can. 4 total connectors. Tether with lanyard	1.1	1.1	3.5	3.1	3.1	4.8	4.1
2. Remove two 1/4" bolts from starter can assembly clamps and stow bolts	0.3	1.4	2.0	*	Abort*	3.9	6.4
3. Place lanyard on starter cans	0.1	1.5	0.3	3.0	0.1	8.8	1.0
4. Remove two bolts from starter can assembly bracket and stow bolts	1.8	3.3	2.9	*	Abort*	7.1	11.0
5. Disconnect two flex hoses from gas generator injectors	2.8	5.1	1.5	6.0	1.3	17.2	1.7
6. Remove ten (10) bolts from top of gas generator injector and stow bolts	1.6	6.7	6.7	17.2	19.0	36.2	24.0
					29.3	48.2	

Table 5-1 (cont'd)
MAINTENANCE TASK SIMULATION
 (Time in Minutes)
Replace Gasket on Starter Generator

Task Requirements	CONTROL CONDITION			SHUTTLE/PRESSURIZED SUIT					
	Δ	Shirt Sleeve Σ	Unpres. Suit Σ	Δ	Sleeves Σ	Δ	Hatch 90 deg Σ	Δ	Hatch 45 deg Σ
7. Remove complete gas generator starter assembly and stow the assembly	0.5	7.2	17.5	0.6	41.1	0.6	36.8	0.6	48.8
8. Remove gasket	0.3	7.5	17.7	0.2	41.5	0.4	37.2	0.8	49.6
9. Install new gasket	0.6	8.1	17.9	0.2	41.6	0.1	37.3	3.5	53.1
10. Replace gas generator starter assembly	0.8	8.9	18.2	0.3	43.5	0.5	37.8	0.4	53.5
11. Replace ten (10) bolts on gas generator	4.2	13.1	27.2	9.0	81.3	18.6	56.4	19.1	72.6
12. Connect two flex hoses to gas generator	0.3	13.4	28.5	1.3	83.9	1.7	58.1	2.2	74.8
13. Replace two bolts on starter can assembly bracket	1.4	14.8	33.2	4.7	Abort*	8.3	66.4	6.0	80.8
14. Remove lanyard	0.3	15.1	33.5	0.3	88.0	8.5	66.6	6.1	80.9
15. Replace two bolts on starter assembly clamps and stow bolts	1.8	16.9	36.5	3.0	Abort*	7.6	74.2	6.7	87.6

Table 5-1 (cont'd)
MAINTENANCE TASK SIMULATION
 (Time in Minutes)
Replace Gasket on Starter Generator

Task Requirements	CONTROL CONDITION		SHUTTLE/PRESSURIZED SUIT				
	Δ	Shirt Sleeve Σ	Unpres. Suit Σ	Δ	Sleeves Σ	Hatch 90 deg Σ	Hatch 45 deg Σ
16. Replace the four igniters on starter cans	3.0	19.9	2.0	38.5	1.4	12.6	90.0**
					(89.4 plus)*	86.8**	2.4

* These operations could not be accomplished due to workers inability to properly reach the bolts or effectively manipulate the wrench. These operations were completed by the assisting test personnel, in order to continue with the balance of the operations.

** Test of Hatch 45 deg was first test conducted in this program resulting in slightly greater accumulative time over Hatch 90 deg which benefited from this experience.

Table 5-2
MAINTENANCE TASK SIMULATION
 (Time in Minutes)
Repair Meteoroid Puncture

Task Requirements	CONTROL CONDITION			SHUTTLE/PRESSURIZED SUIT			
	Δ	Shirt Sleeve Σ	Unpres. Suit Σ	Δ	Sleeves Σ	Hatch 90 deg Σ	Hatch 45 deg Σ
1. Place pre-fabricated hole plug on puncture	0.4	0.4	0.3	0.3	0.5	0.4	0.4
2. Drill pilot hole for cleco fastener or match predrilled plug holes	0.7	1.1	0.2	0.5	0.3	0.2	0.6
3. Install cleco fastener	0.2	1.3	0.3	0.8	1.6	1.7	2.2
4. Drill holes for fasteners to match predrilled plug	0.8	2.1	0.5	1.3	0.4	0.5	2.5
5. Install blind rivets	1.2	3.3	1.6	2.9	3.4	1.7	4.3
6. Remove two cleco fasteners	0.8	4.1	0.4	3.3	0.1	1.0	5.4
7. Stow cleco pliers	0.5	4.6	0.4	3.7	0.1	0.1	5.45
8. Install blind rivets	1.45	6.05	1.6	5.3	1.4	1.55	6.5
9. Stow rivet gun	.05	6.1	.2	5.5	.05	.05	6.55
						7.21	

Table 5-3
 MAINTENANCE TASK SIMULATION
 (Time in Minutes)

Fuel Cell Replacement

Task Requirements	CONTROL CONDITION			SHUTTLE/PRESSURIZED SUIT			
	Δ	Shirt Sleeve Σ	Unpres. Suit Σ	Δ	Sleeves Σ	Hatch 90 deg Σ	Hatch 45 deg Σ
1. Cut lockwire on electrical connector	1.1	1.1	1.2	1.2	1.8	2.2	1.7
2. Disconnect electrical connector	0.1	1.2	0.6	0.6	3.7	0.9	2.5
3. Disconnect fuel line	0.4	1.6	0.3	0.3	*	*	*
4. Disconnect oxygen line	0.1	1.7	0.4	0.4	*	*	*
5. Disconnect water line	0.1	1.8	0.4	0.4	10.5	5.9	4.9
6. Remove top fuel cell assembly mounting bolts and attach crane line	4.7	6.5	4.9	4.9	*	*	*
7. Remove bottom cell assembly mounting bolts	0.7	7.2	3.7	3.7	22.3	25.0	14.1
8. Remove fuel cell		7.2	11.5	11.5	23.2	21.6	20.5
9. Replace fuel cell	0.2	7.6				31.4	22.1
10. Install mounting bolts at bottom	*		*	*	*	*	*
11. Remove crane line and install mounting bolts at top	*	8.8	17.5	17.5	39.1	41.8	30.7

Table 5-3 (cont'd)
 MAINTENANCE TASK SIMULATION
 (Time in Minutes)
Fuel Cell Replacement

Task Requirements	CONTROL CONDITION			SHUTTLE/PRESSURIZED SUIT					
	Δ	Shirt Sleeve Σ	Unpres. Suit Σ	Δ	Sleeves Σ	Hatch 90 deg Σ	Hatch 90 deg Δ	Hatch 45 deg Σ	Hatch 45 deg Δ
12. Connect water line	*		*		*	*		*	*
13. Connect fuel line	*		*		*	*		*	*
14. Connect oxygen line		13.6	18.6		45.7	47.1		35.6	
15. Connect electrical connectors	1.2	14.8	19.4		48.0	49.4		37.4	

* These operations were combined, so separate time increments are not shown.

Table 5-4
 MAINTENANCE TASK SIMULATION
 (Time in Minutes)
 Replace Switch

Task Requirements	CONTROL CONDITION				SHUTTLE/PRESSURIZED SUIT					
	Shirt Sleeve		Unpres. Suit		Sleeves		Hatch 90 deg		Hatch 45 deg	
	Δ	Σ	Δ	Σ	Δ	Σ	Δ	Σ	Δ	Σ
1. Insert shorting plug (thruster)	0.2	0.2	0.7	0.7	0.6	0.6	0.4	0.4	0.5	0.5
2. Remove access plate fasteners	3.1	3.3	2.9	3.6	12.3	12.9	9.7	10.1	5.6	6.1
3. Attach lanyard to access plate	0.1	3.4	0.2	3.8	0.1	12.95	0.1	10.2	0.2	6.3
4. Disconnect MS connector	1.5	4.9	0.7	4.5	2.4	14.4	1.7	11.9	0.9	7.2
5. Remove switch and stow	0.7	5.6	0.7	5.2	1.3	15.7	1.0	12.9	0.4	7.6
6. Install replacement switch	0.5	6.1	0.7	5.9	3.5	19.2	3.9	16.8	6.2	13.8
7. Connect MD connector	0.6	6.7	0.9	6.8	1.0	20.2	1.7	18.5	0.7	14.5
8. Remove lanyard	0.1	6.8	0.1	6.9	0.4	20.6	0.1	18.6	0.2	14.7
9. Install access plate fasteners	1.7	8.5	3.2	10.1	13.4	34.0	7.5	26.4	7.8	22.5
10. Remove shorting plug and stow	0.1	8.6	0.2	10.3	0.4	34.4	0.1	26.5	0.2	22.7

The test proceeded from the easier techniques to the more difficult. The subject performed each task in the following sequences; in shirt sleeves, in the unpressurized Mark 4 suit, in the pressurized suit, and finally in the pressurized suit and the simulated sleeve structure. The subject had previous experience working in the Mark 4 suit, and with the tools used. It is felt that there was little learning effect in his performance without the suit and with it unpressurized. Each task had peculiarities and the performance with the shuttle hatch in two positions reflects a learning improvement in the opinion of the subject. Every 20-minute period under pressure was followed by a 20-minute rest period. The times were obtained with a stop watch which was used to time the total task. The watch was stopped during the subject's rest periods or when extraneous operations are necessary, such as replacing air bottles.

A fundamental premise of the shuttle operation is that the mass and structure of the shuttle should be used to the greatest advantage to support the worker. In most repair operations, the shuttle will also be firmly attached to the target. With a relatively firm foundation, it is expected that the zero-g effects will be relatively unimportant. Therefore, no attempt was made to simulate weightlessness by air bearings or gimbals. The restraints imposed by the necessity of attaching the worker to the shuttle were present in the tests in that the subjects feet were fastened to the floor by the spurs used in F-104 ejection seats. For comparative purposes it is noted that other simulated maintenance tasks are reported in Reference 5-1 in which the same subject operated in a set of gimbals giving him 4 degrees of freedom. Several lighting arrangements were used in the course of the tests. The general conclusion is that 20-to 50-watt lamps produce adequate illumination for the tasks performed. In some cases, 150-watt lamps were used, but these produced objectional highlights and glare from the metallic surfaces

present. The mock-ups used were predominately wood, but these were painted with aluminum paint.

5.3.1 Test Observations

Tools

Standard tools were utilized in the initial testing, including an assortment of ratchet wrenches, end wrenches, flexible and rigid wrench extensions, pliers, Allen-head wrenches, power drills, rivet guns, and Phillips-head screwdrivers. As the need arose, modifications were made to facilitate operations. Wire drift pins were used to help align work during re-assembly operations, and a long-handled mirror was useful in permitting more complete observation of the task-object by the subject.

Ratchet wrench operation was a problem because the worker could neither hear nor feel the characteristic "clicks". At times, he exerted considerable energy without actually knowing whether he was making appropriate progress while using this particular tool assembly. A possible solution might be to provide for electronic "sensing" of the "clicks" and notification to the subject by means of varied audible tones directed to his ear, or by varied patterns of vibration distinct enough to be "sensed" through the gloves.

All of the tools were found to require modifications to provide handle surfaces of greater diameter, as well as modifications to insure retention of grip on the work-object, with provision for manual control of the retention device by the user. The retention device would insure contact with the work-object, allow the user to rest periodically without jeopardizing the progress of his work, and prevent loss of the extracted fastener.

Operation of the standard (1/4-in. chuck) drill quickly caused hand-fatigue, because of its weight and shape. Addition of a front pistol-grip handle would permit one-handed operation, using either handle, and would permit

"switching" hands to either forward or rear handle. Under zero g, only accelerations produce any "weight" effects so the experimental results are pessimistic in this regard.

Standard Cleco pliers were used in the test, although they should be modified to prevent loss of the Cleco fastener from the jaws of the tool. The present design requires that constant pressure be exerted by the worker to hold the fastener securely. The worker cannot effectively "sense" the degree of pressure necessary to retain the fastener in the pliers, because of the pressurized gloves.

The blind rivet gun was also unchanged in the test; however, it should be modified to prevent loss of the blind rivet from the front aperture. This tool requires two-handed operation by the subject in a pressurized suit and gloves, making it difficult for the worker to retain the rivet in the gun during his approach to the work-object.

The Mark 4 suit appears to be unsatisfactory as a space maintenance garment because it is not sufficiently mobile and the worker has to fight the suit in order to accomplish his tasks.

Gloves

Improvement of the gloves is imperative to permit critical tactility, ease of manipulation, and better access to structurally restricted task areas. Finger length and sizing are critical factors and flexibility to permit small-detail finger manipulation is an essential requirement.

The Arrowhead glove proved to be best when uninflated; when inflated, it had a tendency to "balloon" excessively and induced an appreciable amount of hand-fatigue. The Goodrich glove did not stretch as much as the other model and is considered the better glove in the inflated condition.

Lanyards

Lanyards were included in the test to determine effects on tool manipulators. It is essential that parts and tools be anchored to prevent their loss and the lanyard is one device for accomplishing this objective. However, the lanyards had a tendency to tangle and further work should be done in designing a method to avoid this problem. (It might be possible to construct a retractable lanyard which could be arrested at various lengths and easily released by use of a detent).

Access

In general, the worker found a need for more working room. In the "sleeve" configuration, the subject was unable to get both hands into a task area at the same time, and his visual observation of the work in progress ranged from "extremely difficult" to "impossible".

Bolts

Removing bolts was a slow operation. Threaded bolts should be redesigned to provide for minimum thread area with an unthreaded tapered section at the end to permit using the bolts as drift pins for alignment of work-objects during reassembly operations. This arrangement would serve also to prevent cross-threading, because it would aid in properly positioning the bolts.

Lock-wires

In general, lock-wires were difficult to remove. The use of lock-wires also introduces a hazard, because the gloves are sensitive to penetration. A spring device would probably represent an effective substitute for the wires.

Sleeve Arrangement

The sleeve arrangement was found to impose more constraints on the worker than the open-hatch configuration. The use of both armpieces prevented the subject from twisting his body to improve his contact with a

particular work object. Dexterity and coordination were hampered by the arrangement's inflexibility. By removing one arm from the armpiece, the worker could increase his reach, but he was then restricted to one-handed work.

Hatches

The open-hatch configurations are more convenient for maintenance purposes than the fabric armpiece concept. The hatches permit the worker to lean out and effectively "dive" into his work, and permit more freedom of head and torso movement generally. The 45-deg hatch is a little more convenient than the 90 deg hatch, because it facilitates movement of the shuttle vehicle to attain better proximity to the task.

Vehicle Movement

It is essential that both the shuttle and the task vehicle be movable at least one foot in either a vertical or horizontal direction. Relative movement is necessary for effective observation and complete access by the worker. As a natural concomitant, this maneuverability would result in conservation of time required to accomplish certain operations. It would be extremely helpful if one vehicle could be rotated slightly, because this additional maneuver would contribute to even better observation and accessibility.

The method by which the two vehicles are tethered will influence both controlled relative motion, and the restraint of vehicular motion which is required in order for work performance. The open hatch configurations would be a little less dependent on large relative motion than the configuration utilizing the fabric armpieces.

5.3.1.2 Psychophysiological Considerations

Frustration

Successful completion of some task operations was occasionally thwarted

because of certain design features inherent in the task and shuttle vehicles, the unsuitability of various tools, and because of the physical restraint imposed by the pressurized suit. Frustration appeared to cause the subject to "overheat" and induced a marked degree of fatigue during relatively short operational periods.

Fatigue

Repeated attempts to accomplish even less significant tasks often led to frustration and fatigue, because of task inaccessibility and suit and tool restraints. Typical symptoms of fatigue appeared as increased awkwardness in manual manipulation and an increased tendency to drop tools and fasteners. The subject consistently reported the rapid development of feelings of fatigue in his hands, especially when the particular task required the use of tools with small handles.

5.3.2 Maintenance Technique Evaluation

The several techniques for giving the space worker the necessary visual and physical contact with the problems outlined in para. 3.2.4 are discussed in this paragraph in the light of the test results of the preceding paragraphs. The technique of working inside the pressurized capsule when the size of the part to be maintained permits, and the technique of working through a mating hatch in a pressurized target, are similar insofar as the worker is concerned, although the design of specific satellites may impose access problems of different degrees of severity. The test results shown for a worker in an unpressurized suit, are therefore applicable to both of these cases.

The shelter technique, designed to allow the worker to perform effectively while retaining the major protective advantages of the shuttle, is represented by the test results with the hatch in the 90- and 45-deg position. It is noted that neither of these cases seriously restricts the operation and

that the capability and training of the worker overshadow the effect of the constraints imposed. The shelter not only provides meteoroid protection and thermal control of the environment, but provides a container for loose or dropped pieces. The shelter eliminates the barrier between the worker and his work, his tool, and spare parts.

The worker is still, however, exposed to vacuum and must wear a pressurized suit. Furthermore, the shelter adds to the weight and complexity of the shuttle design, and requires that the shuttle incorporate a very large opening. To these disadvantages are added the complications of designing the extendable shelter itself. These drawbacks can be partly minimized. For example, if the mating-docking hatch is sufficiently flexible, a single hatch will suffice.

The major objection to the shelter is overcome by use of the sleeves. Use of the sleeve technique permits the worker to dispense with the pressurized suit and to function more comfortably with less fatigue. His hands must nevertheless remain enclosed in pressurized gloves, and if he must wear the pressurized suit for reasons of safety, he will be wearing two pairs of gloves. Use of the sleeves also imposes constraints upon the design of both satellite and shuttle. Because the worker in the shelter will have limited mobility, it will be necessary to shift the entire shuttle easily, and to lock it into place rapidly. In the tests conducted, frequent movements of 6 to 8 inches were found to be needed. Sleeves require that the worker have either external storage for tools and spare parts or a small airlock through which he can pass objects. Extendable mirrors and adjustable probes are needed to enable the worker to function anywhere besides the surface of the vehicles. Problems presented by the use of sleeves include difficulty in using both hands at once, difficulty in seeing what is being worked on, handling bulky objects (as long as the worker's arms), or removing big objects from the target and stowing them in the shuttle.

To extend the worker's reach and increase his mobility while protecting him, will require mechanical manipulating devices so that he can work from within the shuttle. A great variety of remote handling devices and manipulators capable of handling difficult tasks are described in Ref. 5-2.

The shuttle operator's tasks fall into four categories, defined in Table 5-5. One category includes tasks concerned with handling the complete vehicle; another relates to handling large components; two relate to the performance of small, precise operations. The applicability of the manipulators in Ref. 5-2 to these various types of tasks is summarized in Table 5-6.

Some operations such as repairing the engine or removing the switchbox behind the fuel cell (see Figs 5-11 and 5-15) cannot be accomplished with any of the listed devices because manipulators which afford sufficient dexterity must have minimum clearance of six inches. In general, the weight and power requirements of the manipulators are disappointingly high, and the load and dexterity capabilities disappointingly low; strength and rigidity problems are also difficult.

Although the most natural approach to the design of a multi-purpose manipulator is to imitate the human hand, the classification of manipulator characteristics suggests that manipulators designed specifically to work with satellites and tools may be more successful than the anthropomorphic approach.

Table 5-5
MANIPULATOR REQUIREMENTS

Type	Characteristics	Application	Number per Shuttle
Grapple	Quick attach - release to cooperative and uncooperative targets. Position control.	Docking, alighting and towing cargo	3
Holst	Payload grips, precise positioning of objects about shuttle, stiff, high load capacity.	Handle payload, e.g. fuel cells, perform mating in assembly mission	2
Forceps	Grip and precise positioning of small components, e.g. nuts, bolts, electronic components, covers. Long reach, small envelope.	Position and retain components	2+numerous size heads
Torquer	Flexible shaft driven socket, Allen, etc., wrench. Oblique and 90 deg heads, plumbing electrical disconnect attachments interchangeable. Long reach, small envelope.	Use on mounting bolts of fuel cell, on gasket change parts, etc.	1

Table 5-6

MANIPULATOR CHARACTERISTICS

Manufacturer and Model	Nortronics	Gen'l Mills		Hughes Mobot II	Gen'l Elec. Handyman	AMF LDMSM	AMF Mini-Manip.
		#100	#700				
Amount and Type of Power	Electro-Pneumatic	2.0 KVA Electro-Mech	50.0 KVA Electro-Mech	Electro-Mech	Electro-Hyd.	Electro-Mech	Mech
Overall Weight (lb)		430				175	16
<u>Performance</u>							
Grip (lb)		50	1500	80		8	5
Lift (lb)		40	500	25	75	10	5
Reach in		56	9 1/2 ft	66 1/2	55	73	24
<u>Versatility</u>							
No. of arms	1 Hand	1	1	2	2	1	1
No. of joints/arm							
Last Joint		2	2	4	5	2	2
<u>Rotation about pivot</u>							
Rotation about own axis		None	180 deg	180 deg	90 deg	167 deg	
<u>Clearance arm</u>							
Min dia		Continuous	Continuous	Continuous	Continuous	± 176 deg	
Max speed		6 in.	75 rpm	6.5			
Linear		40 rpm	20 rpm	10 rpm			
Rotation		50 rpm		10 rpm			
Controlled with	Glove	Switches or Pistol Grip	Switches or Pistol Grip	Switches and Pedals	Gloves and Sleeves	Pistol Grip	Pistol Grip

Table 5-6 (cont'd)

MANIPULATOR CHARACTERISTICS

Manufacturer and Model	Nortronics	Gen'l Mills #100	Gen'l Mills #700	Hughes Mobot II	Gen'l Elec. Handyman	AMF LDMSM	AMF Mini-Manip. Mech
Amount and Type of Power	Electro-Pneumatic	2.0 KVA Electro-Mech	50.0 KVA Electro-Mech	Electro-Mech	Electro-Hyd.	Electro-Mech	Mech
Feedback Force Touch Comments	Yes Yes Bread Board Model	Gages Gages Wt. and Power Excessive for Shuttle	Gages Gages		Yes No Versatile	Manipulator Ends Interchangeable	Tongs
Shuttle Application	Forceps	Grapple hoist				Torquer	Forceps

5.3.3 Conclusions

The considerations of the various maintenance techniques are summarized in Table 5-7 and a simplified scoring system presented to evaluate each. The relative value of each technique on the basis of weight, access and visibility, time required for repair and technical effectiveness, is rated on a scale of 1 to 5. Technical effectiveness measures the relative detail in which the maintenance task may be performed; for instance, an unpressurized worker is expected to perform any sort of detailed task required, but a manipulator is expected to do no more than replace sizeable modules. The applicability factor is a multiplying factor applied to the sum of the previous four, and measures the relative number of missions that might be accomplished by each technique. Again a scale of 1 to 5 is used so that the total possible score is 100. The ranking of the various techniques is believed to be valid, but the scoring system is not intended to give a quantitative estimate of relative worth. However, it is believed the conclusions are valid. The high score of the shelter technique results from its versatility in that it brings the worker into direct contact with the job and is applicable to all satellites. The low score of the hatch technique is due to the low applicability factor when applied to existing and presently planned targets. For targets designed to accept this technique, the rating would be highest of all. Similarly it is anticipated that targets and manipulators designed for a specific mission might be the most suitable of all for that mission.

As the shuttle must deal with uncooperative satellites, the shelter is indicated. It is expected that future developments will bring greater use of the hatch and manipulator operation.

Table 5-7
REPAIR AND MAINTENANCE TECHNIQUE EVALUATION
Special Requirements Imposed

Technique	Applicable Space System	Target Systems	Shuttle Systems	Primary System	Wt. Merit	Access and Viability to Problem	Time Merit for Repair	Tech. Effic.	Applicability Factor	Total Merit
1. Tow target to primary and repair in air/serve environment	Small satellites such as: Nimbus OAS Teistar Mercury Gemini Apollo, LEM.	1. Compatible size 2. Tow points	1. Suitable Grapplers 2. Compatible control system	1. Repair Comp't large enough for target 2. Repair facilities 3. Normal shuttle provisions	5	5	3	5	3	54
2. Hatch Enter target and repair in unpressurised space suit	Specially designed cooperative satellites and space station, Apollo, LEM.	1. Docking hatch coordinated with shuttle 2. All systems repairable from inside	1. Docking hatch coordinated with target	1. Normal shuttle provisions	4	4	5	4	1	17
3. Shelter Work under thermal and meteoroid shelter in pressurised space suit using shuttle as work platform	All	1. None	1. Alighting technique 2. Shelter	1. Normal shuttle provisions	4	4	4	4	5	80
4. Sleeves Work through pressurised sleeves attached to pressurised capsule with worker in unpressurised suit	All	1. None	1. Alighting technique with capability for shifting shuttle along 6 axes 2. Sleeve system 3. Tool and part air lock	1. Normal shuttle provisions	4	3	4	3	3	70
5. Manipulators Work through remote manipulation in unpressurised space suit from within pressurised capsule	All	1. None	1. Alighting technique with capability for shifting shuttle along 6 axes 2. Sophisticated manipulators 3. Tool and part air lock	1. Normal shuttle provisions	2	2	2	2	3	40

5.4 ONE-MAN VS MULTIPLE CREW

The shuttle missions and human capabilities are reviewed in this section to determine whether more than one crew member is needed.

Situations which demand more than one man may be classified under the headings of:

- Simultaneous tasks
- Tasks requiring a helper
- Tasks requiring special skills
- Arduous or long missions
- Safety

The tasks of operating the shuttle and the mission tasks of repair and maintenance generally do not occur together. When the repair task requires use of the hover mode, the stabilization and control system relieves the crew of operating the shuttle. Guiding the shuttle to the target requires simultaneous monitoring of the radar or visual display, attitude, and thrust control; however, this combination of tasks is done better by one man. The operation of alighting on and attaching grapples to another satellite might be easier with one man to operate the shuttle and one to operate the grapples, but the attitude hold capability allows these tasks to be done in sequence. A complex repair operation might include tasks that could be performed simultaneously, but it is unlikely that more than one man will have room to work unmanned satellites from a single shuttle.

A maintenance task that requires taking many test readings would be expedited by having one man to make the connections and one to read this instrument; however, the second man is not essential. If test points in the target are located to facilitate maintenance from the shuttle, there is little advantage to using two men.

It is anticipated that space workers will be capable of operating the shuttle. The design presented in Section 6 is capable of carrying a second man, but this is more of a pilot-passenger arrangement than a two-man crew.

The five-hour mission anticipated for the shuttle is not long enough to demand off-duty rest periods for most missions. Tasks that require protracted effort in a pressurized suit are very fatiguing, and providing a second crew member for such tasks would be desirable if they occur frequently.

Adding crew members to the shuttle increases the exposure without decreasing the risk as all members of the crew are exposed to the same hazards and must rely on the same vehicle. Maintaining a standby vehicle and crew for rescue should emergencies arise is suggested.

In summary, there is no need for more than one man for the missions considered in this study, but as complex maintenance missions become more frequent, a two-man shuttle might be more efficient.

Section 6
PRELIMINARY DESIGN

6.1 GENERAL DESCRIPTION

6.1.1 Introduction

From data generated in the preceding sections of this report, the vehicle requirements, and a preferred general arrangement, as shown in Fig. 6-1, are established.

This section of the report defines the detail design of the shuttle vehicle, the major characteristics of the functional subsystems; it also includes structural and weight analyses.

The determination of a feasible method of accomplishing shuttle adherence to a target vehicle and a device for grasping and handling various modules is described in Section 6.11. Section 6.12 describes an approach to achieving a suitable reliability goal.

Advantage is taken of knowledge gained during current space system hardware development in the important areas of propulsion and environmental control and life support through the various vendors directly associated with these programs. Their contributions are identified where used, and their data recognized in the list of references.

6.1.2 Arrangement

The shuttle configuration, as shown in Figs. 6-1 and 6-2, serves as an effective "work platform", equipped with the necessary facilities to perform a wide variety of in-space tasks. The design is adaptable to changing circumstances as space systems develop in complexity and sophistication.

The basic vehicle is adaptable to a variety of canopy sections which may incorporate alternate methods of accomplishing repair and maintenance. Several alternate arrangements made possible by this feature are shown in Figs. 1-1, 6-3, 6-4, and 6-5. The arrangement shown in Fig. 1-1 is a stripped down, lightweight version, which has the potential capability to be integrated into a Gemini flight test program. Figure 6-3 shows an approach for carrying one passenger. Arrangements for accomplishing maintenance tasks remotely are shown in Figs. 6-4 and 6-5.

The configuration design develops the vehicle as a combination of two primary modules, the aft or basic capsule and the front or canopy capsule.

Basic Capsule

The aft or basic capsule section forms the foundation upon which the alternate canopies may be mounted. This section of the vehicle houses the man and the various subsystems of life support, environmental control, propulsion, attitude control and power systems.

Modular Subsystem Arrangement

Wherever practical, a modular approach to subsystem packaging is used. Careful attention is paid to avoid "stacking" of system modules. The modules can be serviced or replaced without excessive disturbance of other systems.

6.1.3 Propulsion Installation

The propulsion system is exterior to the cockpit to eliminate the possibility of propellants contaminating the cabin atmosphere.

Propulsion Tankage Module

Propulsion tankage and associated plumbing systems are mounted in an insulated module on either side of the vehicle, and located centrally about the c.g. to avoid c.g. shift during propellant usage. This module is easily removed for tank maintenance. Refueling may be accomplished through fill-umbilicals located near the engine cluster as shown in Fig. 6-6. Heating elements in the tanks maintain acceptable propellant temperatures.

1

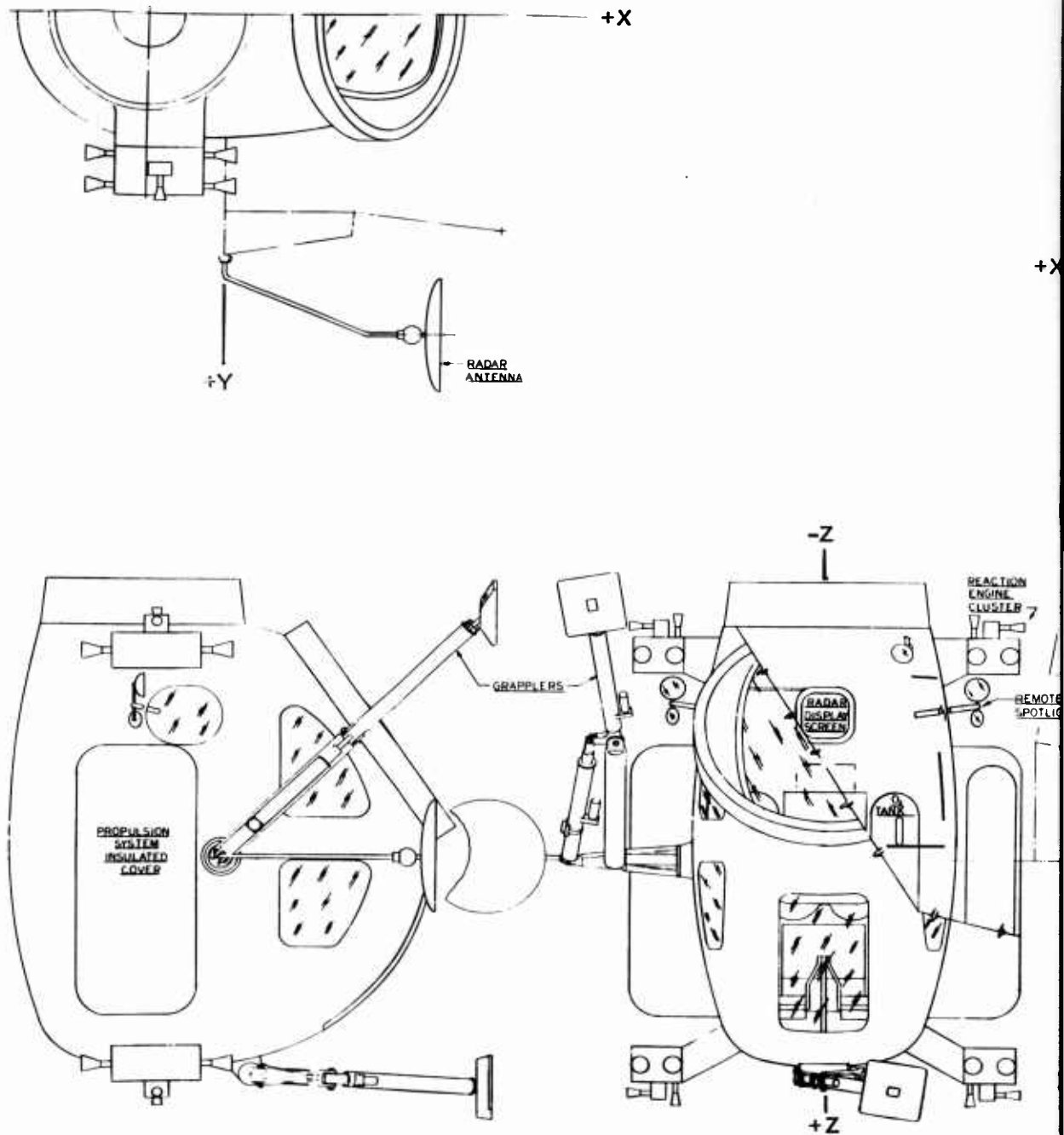
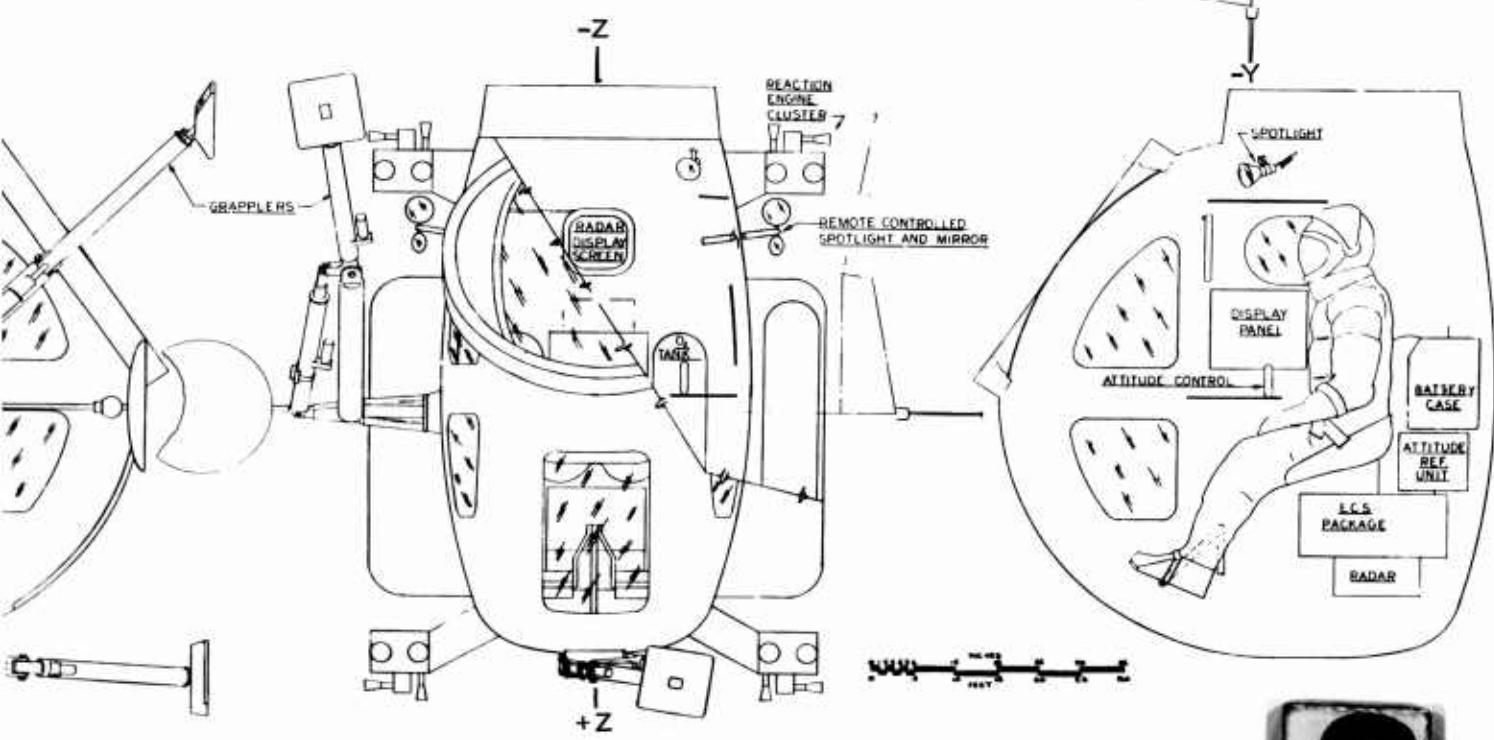
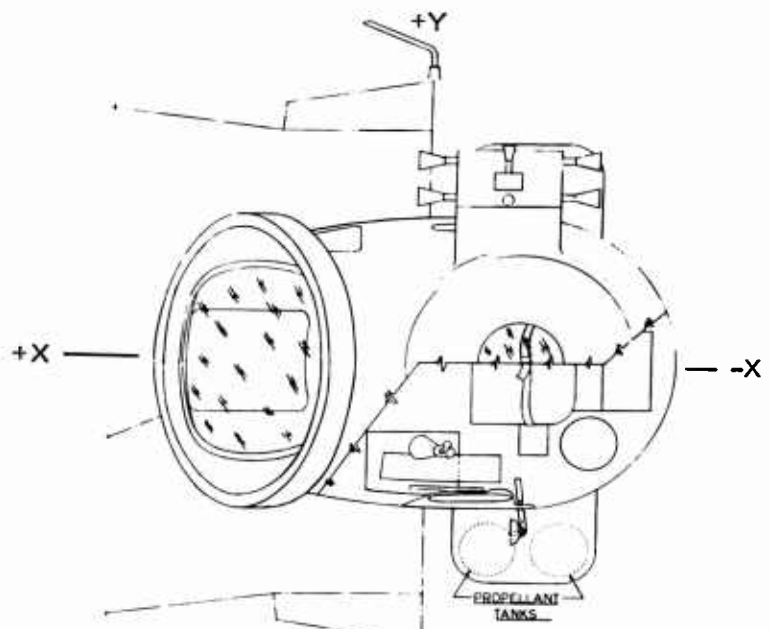
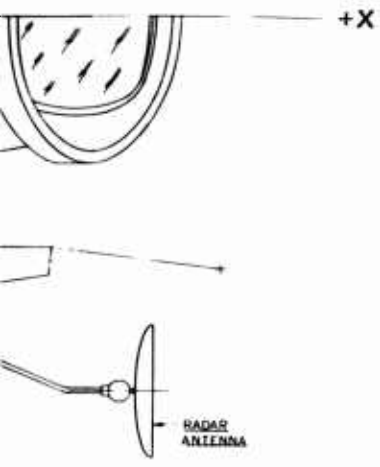
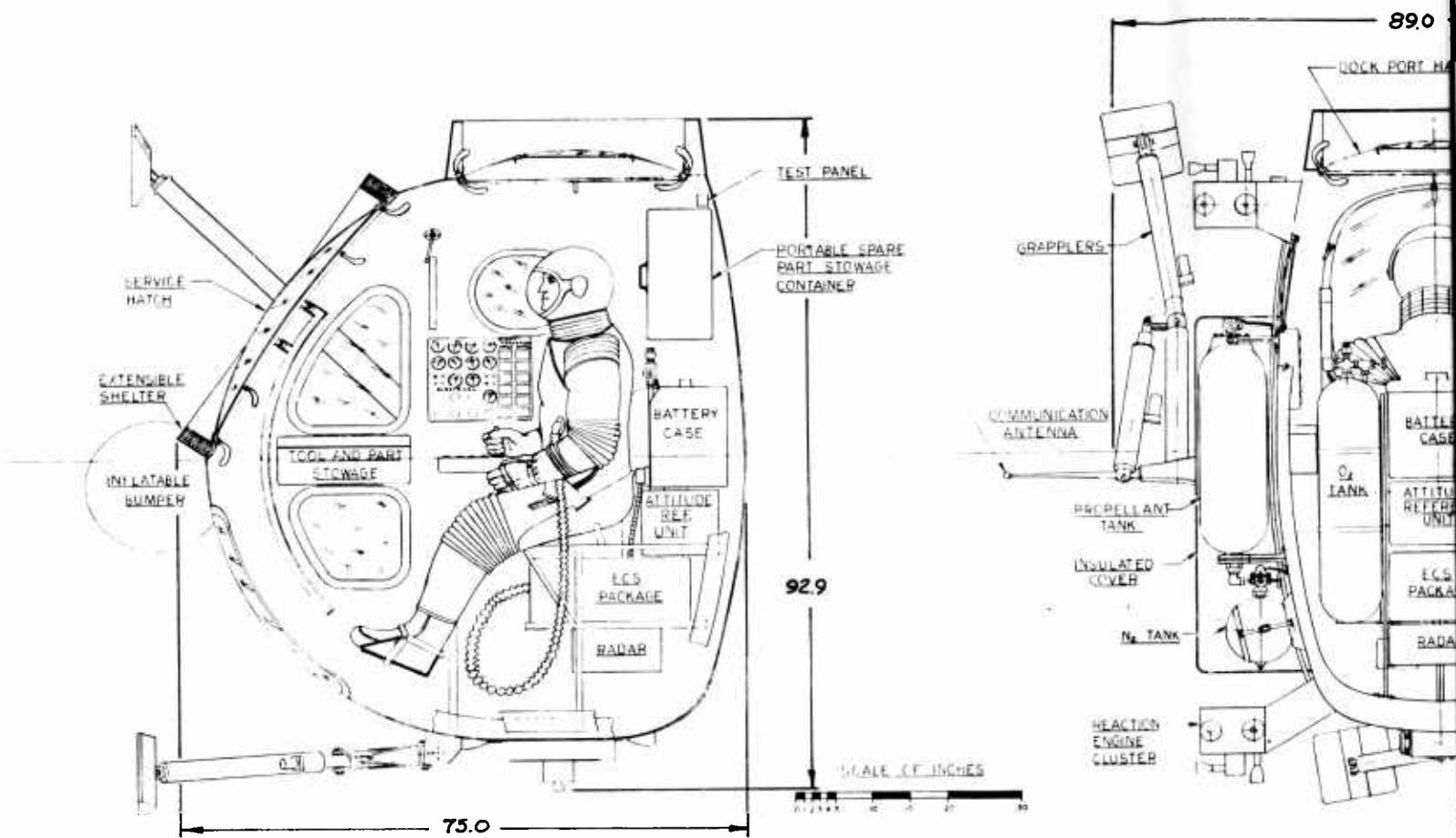

FIG. 6-1 SHUTTLE GENERAL ARRANGEMENT



2



1

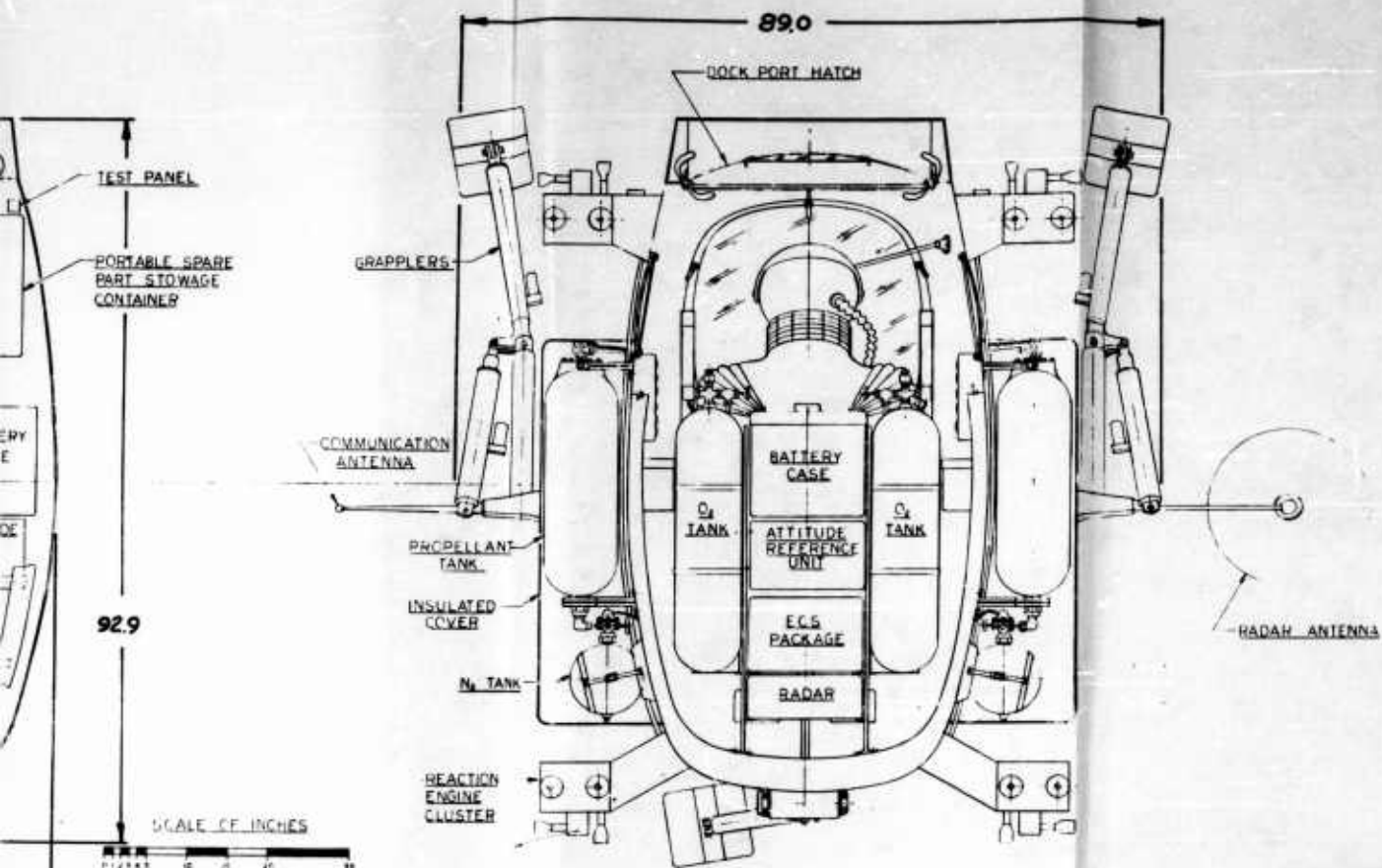

2

FIG. 6-2 SHUTTLE INBOARD PROFILE

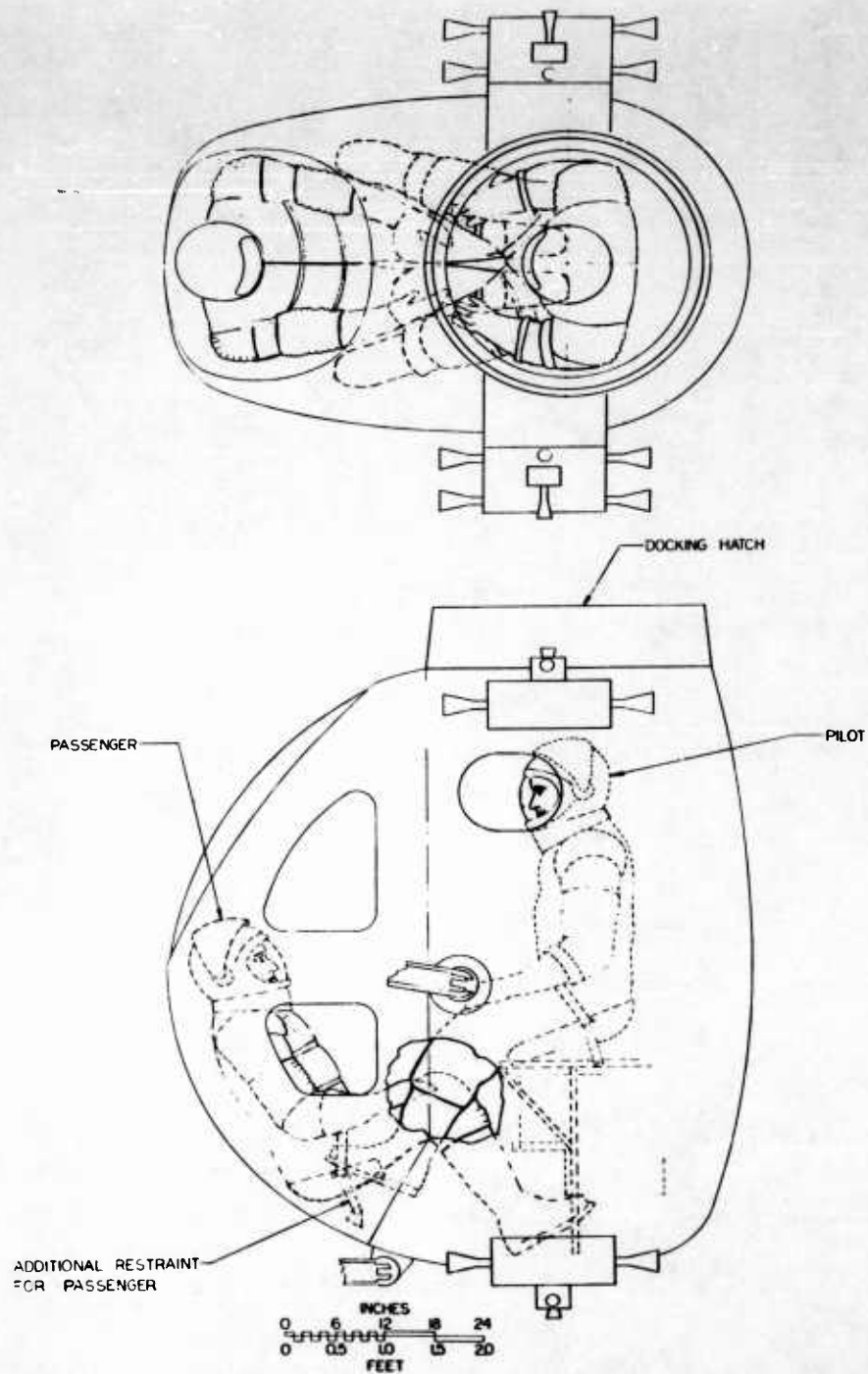

FIG. 6-3 SHUTTLE PILOT AND PASSENGER ARRANGEMENT

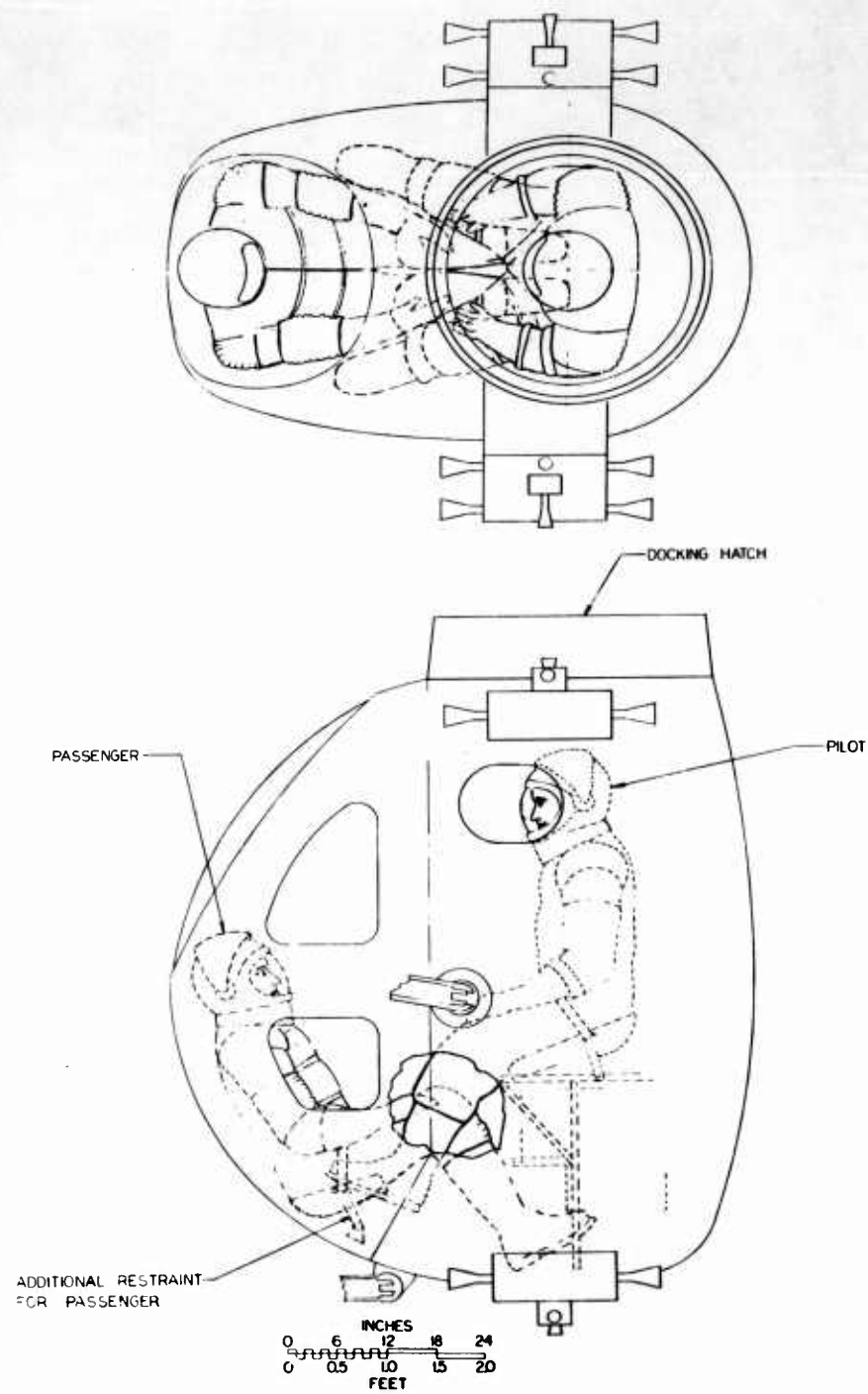

FIG. 6-3 SHUTTLE PILOT AND PASSENGER ARRANGEMENT

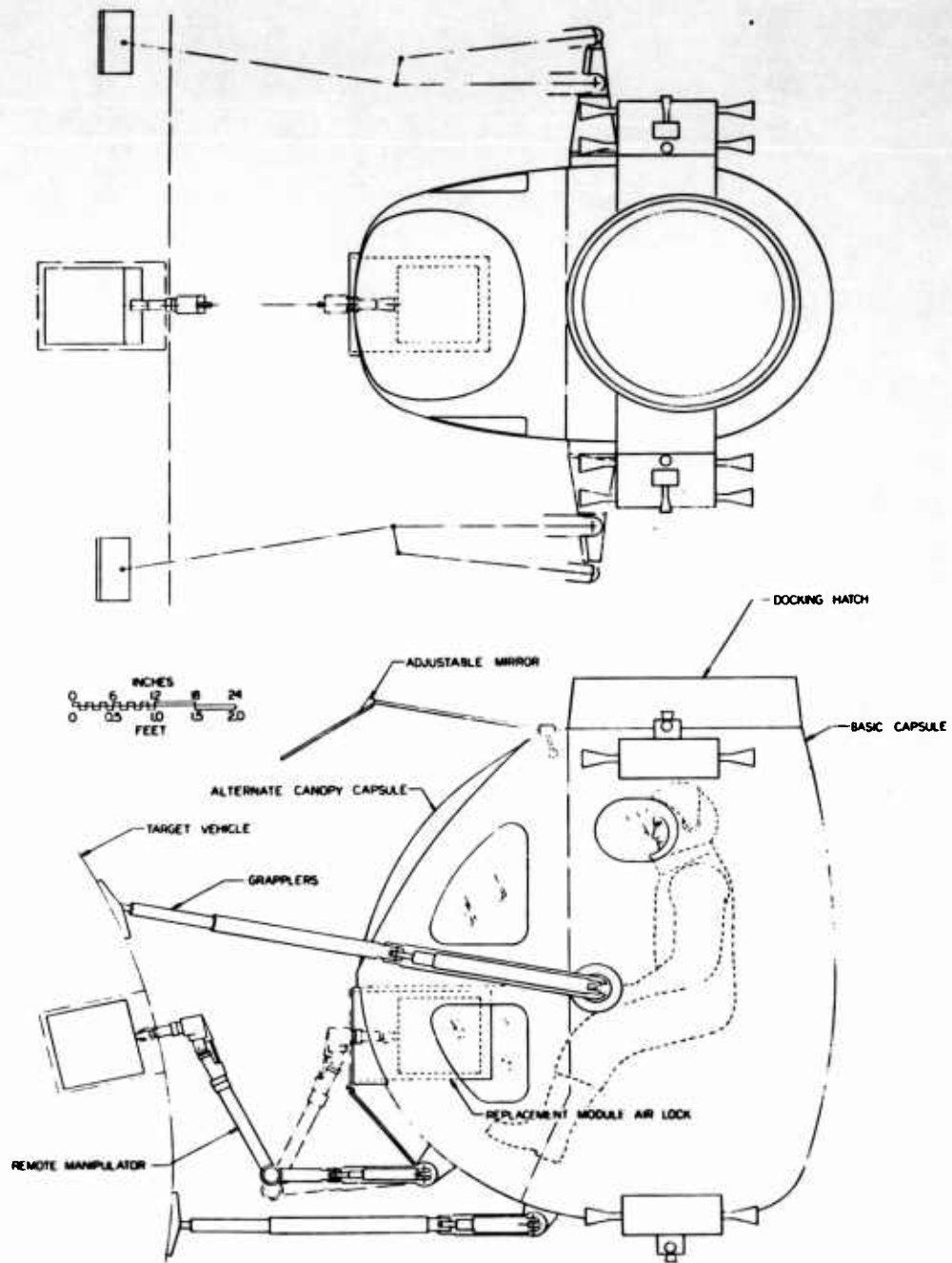

FIG. 6-4 SHUTTLE REMOTE MANIPULATOR ARRANGEMENT

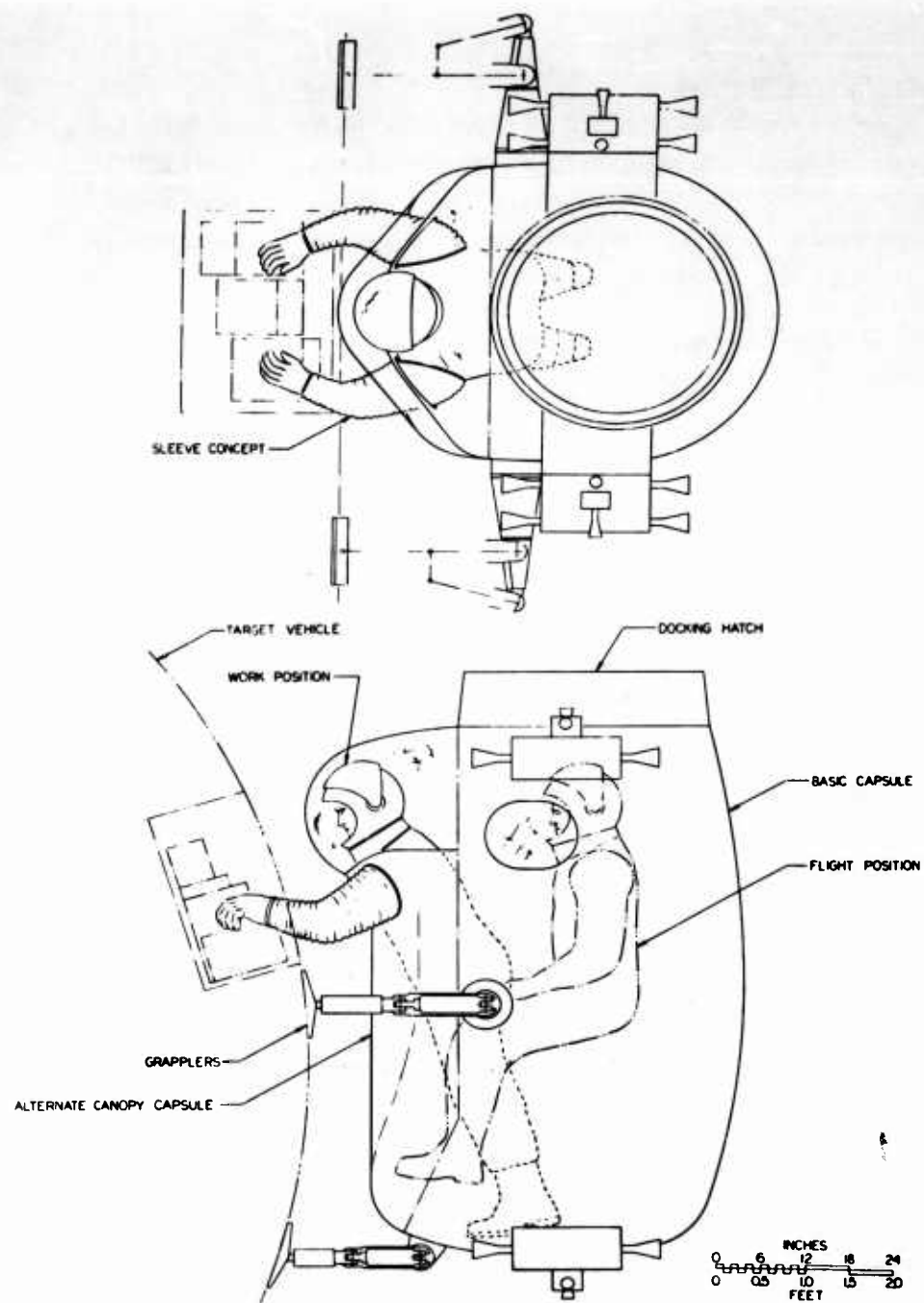

FIG. 6-5 SHUTTLE SLEEVE ARRANGEMENT

Engine Cluster Modules

Rocket engine clusters are disposed at the four corners of the basic capsule. All clusters lie in the Y-Z plane which passes approximately through the c.g. Each cluster contains four 25-lb thrusters and two 5-lb thrusters, Fig. 6-7. In addition to the rocket chambers, the module contains the valving and transducers necessary for monitoring and checkout of the unit.

The cluster mounts onto an outrigger type structure incorporated into the capsule. Quick disconnects facilitate ready removal for repair.

Heater elements and insulation provide thermal control compatible with the propellants.

6.1.4 Docking Hatch

A docking hatch, as shown in Fig. 6-8, is incorporated in the upper basic section to provide ingress and egress to the primary vehicle. This hatch is inward opening and incorporates a window for viewing the final lock-on operations. "O" ring type seals at frame interface are used to ensure pressure integrity.

Quick opening fasteners, operable from both sides of the hatch, are equipped with suitable handles for a space-suited man to provide ready means for fastening and handling of the hatch. A roller/track system facilitates storage of the hatch in the rear section, away from the hatch opening.

A pressure relief valve is incorporated to permit depressurization from the outside in case of emergency. The conical structure, extending above the hatch, is purely conceptual in view of the lack of specific interface data relative to the primary.

6.1.5 Grapplers

Remotely operated grapplers are used by the shuttle to attach to the target during maintenance, handling and transporting cargo or personnel modules, and the tasks associated with in-space assembly of space station modules.

1

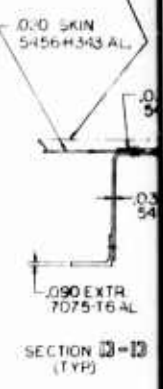
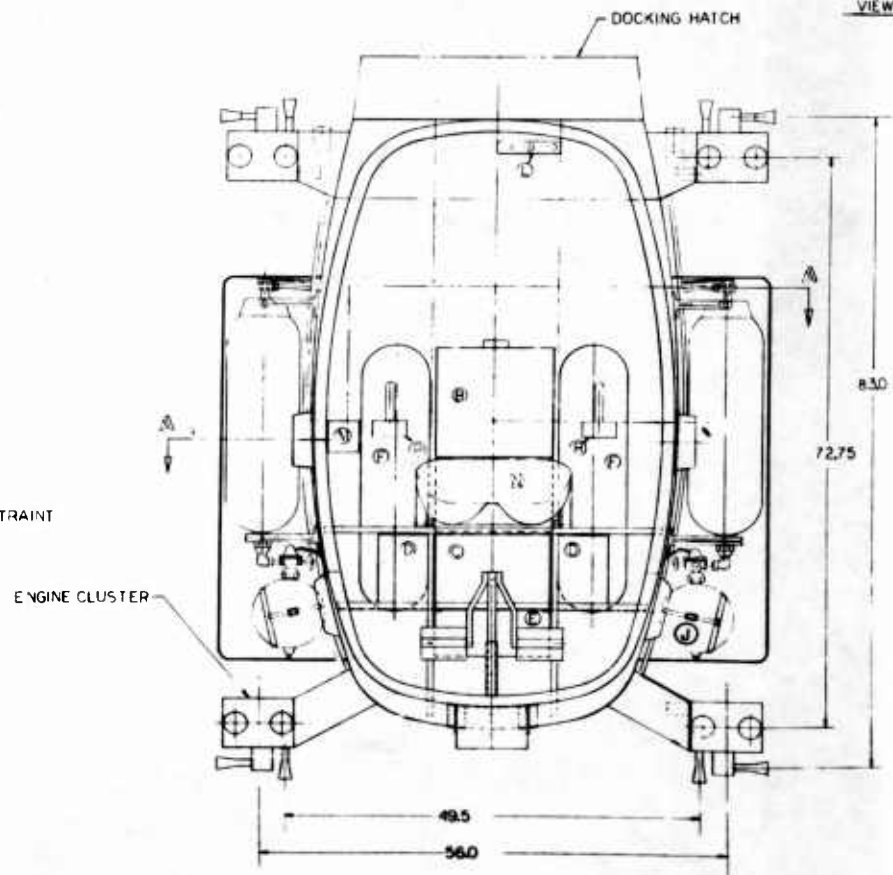
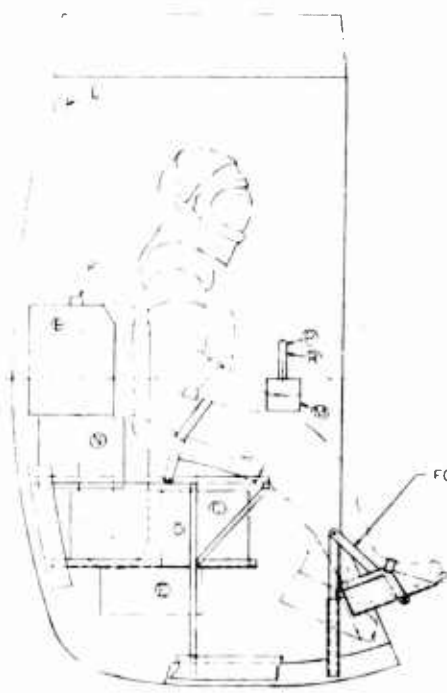
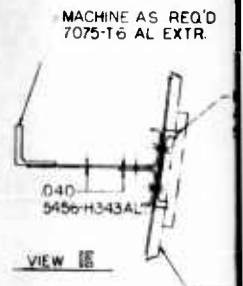
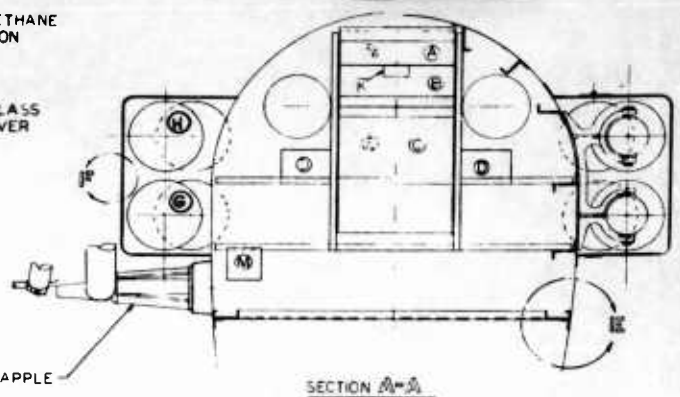
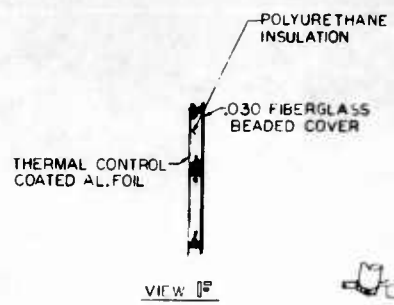

GRAP
CENTER GRAP

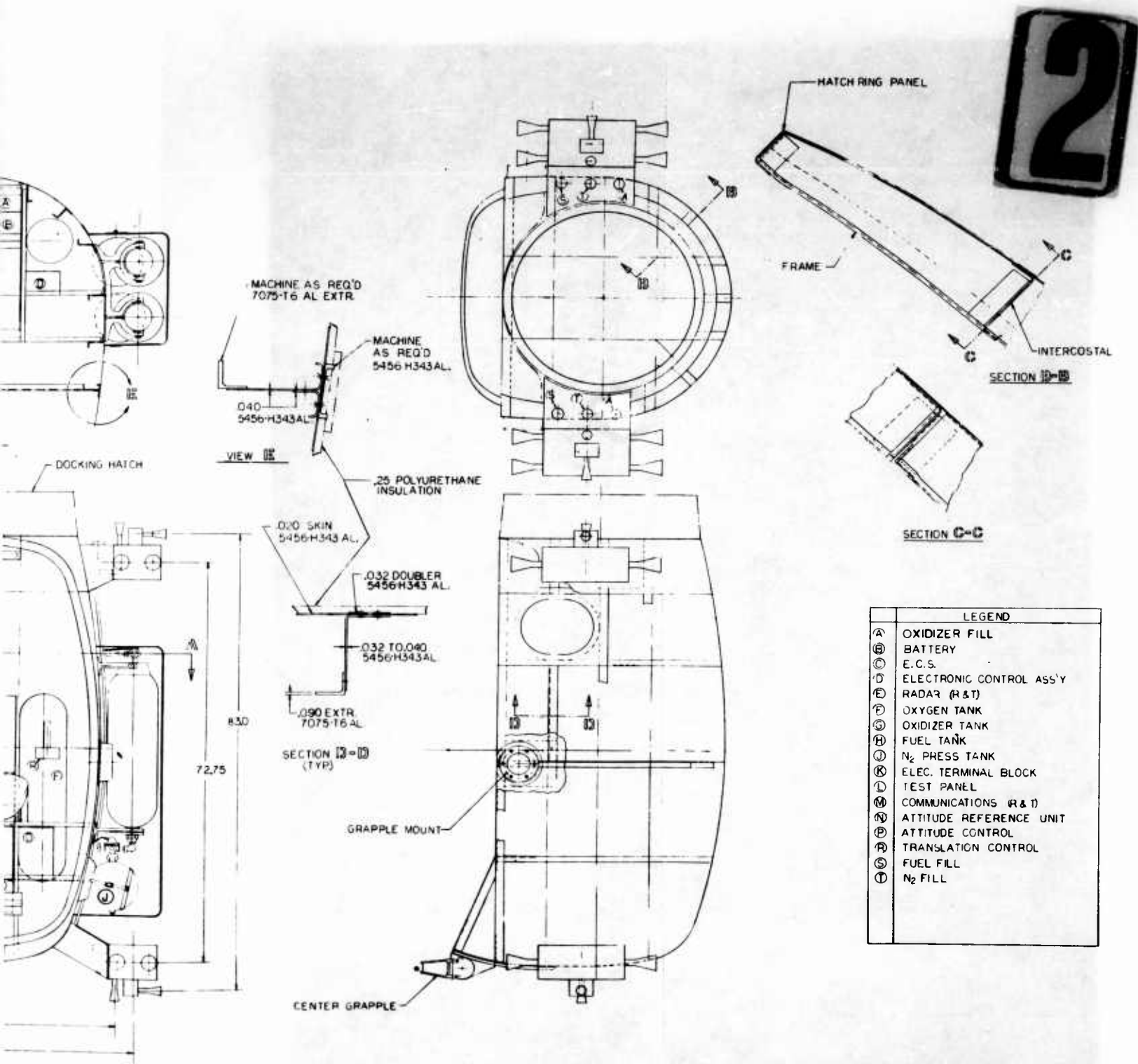

LEGEND	
Ⓐ	OXIDIZER FILL
Ⓑ	BATTERY
Ⓒ	E.C.S.
Ⓓ	ELECTRONIC CONTROL ASS'Y
Ⓔ	RADAR (R&T)
Ⓛ	OXYGEN TANK
Ⓜ	OXIDIZER TANK
Ⓝ	FUEL TANK
Ⓟ	N ₂ PRESS TANK
Ⓠ	ELEC. TERMINAL BLOCK
Ⓡ	TEST PANEL
Ⓢ	COMMUNICATIONS (R&T)
Ⓣ	ATTITUDE REFERENCE UNIT
Ⓤ	ATTITUDE CONTROL
Ⓥ	TRANSLATION CONTROL
Ⓦ	FUEL FILL
Ⓧ	N ₂ FILL

FIG. 6-6 SHUTTLE BASIC CAPSULE 273

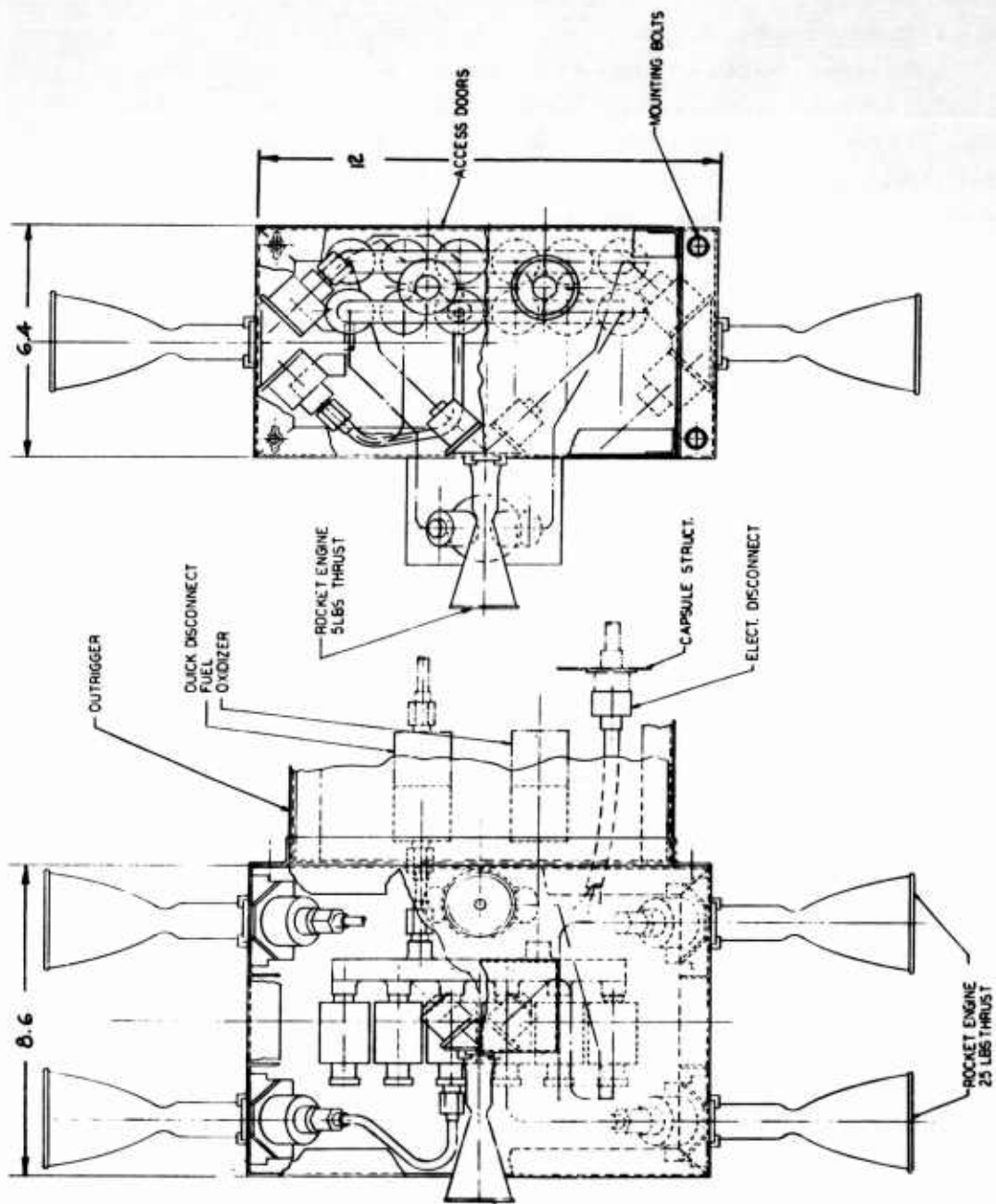

FIG. 6-7 SHUTTLE ENGINE CLUSTER

6.1.6 Capsule Shapes

The capsule bodies are shaped to fit man and his equipment as closely as possible to reduce vehicle size and yet approach a spherical pressure vessel to minimize the weight. The aft capsule approaches a dome-ended segment of a barrel whereas the forward capsule approaches a segment of a dome-ended cylinder. The two segments are joined at a main structural ring at the interface. With an adequate ring at this interface, the balance of the structural elements act as catenary elements, thereby avoiding high bending stresses and consequent weight penalties.

6.1.7 Canopy Capsule

The canopy or forward section, as shown in Fig. 6-9, incorporates the primary view ports and main window hatch which can be opened for maintenance tasks.

Working Hatch

A generous-sized hatch is provided in the upper forward canopy through which the worker may accomplish repair and maintenance tasks on the target. This hatch includes the main forward viewing window. The hatch is opened by six quick-opening fasteners with handles suitable for operation by a man in a space suit. Double "O" ring seals in the framing insure adequate sealing in the closed position.

The hatch opens inward to take advantage of cabin pressure for good seal operation. It incorporates a set of rollers which operate in a set of tracks, which guide the hatch to a stored position in the lower forward canopy section.

Windows

All windows are of the chem core or equivalent type. The glass is hermetically bonded and fastened into cast aluminum framing to minimize leakage. An outer panel of plex 55 serves as a meteoroid bumper, incorporating suitable ultraviolet filtering and thermal attenuation characteristics. A typical installation is shown in Fig. 6-9.

1

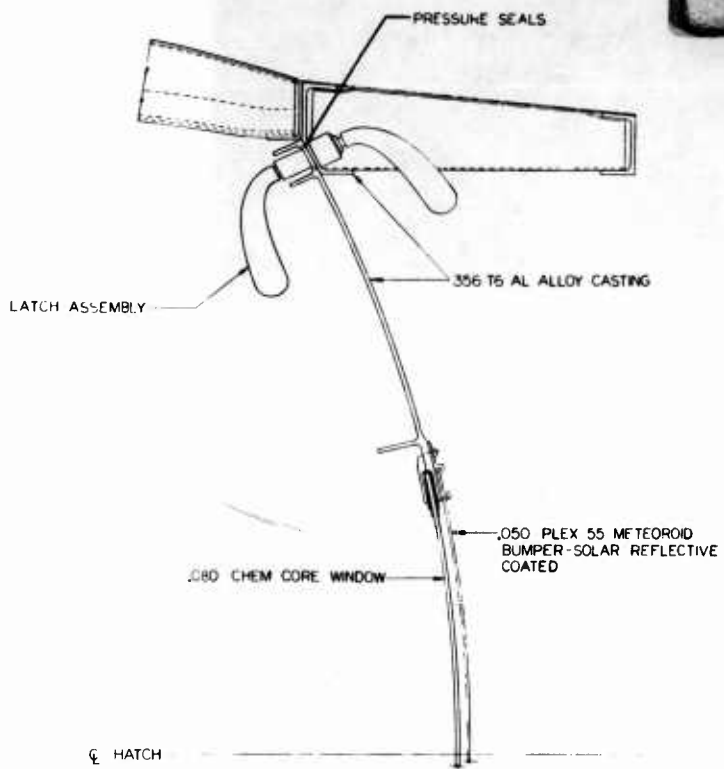

SECTION C-C
FULL SIZE

AIR RELIEF VALVE

HATCH SHEAR PINS

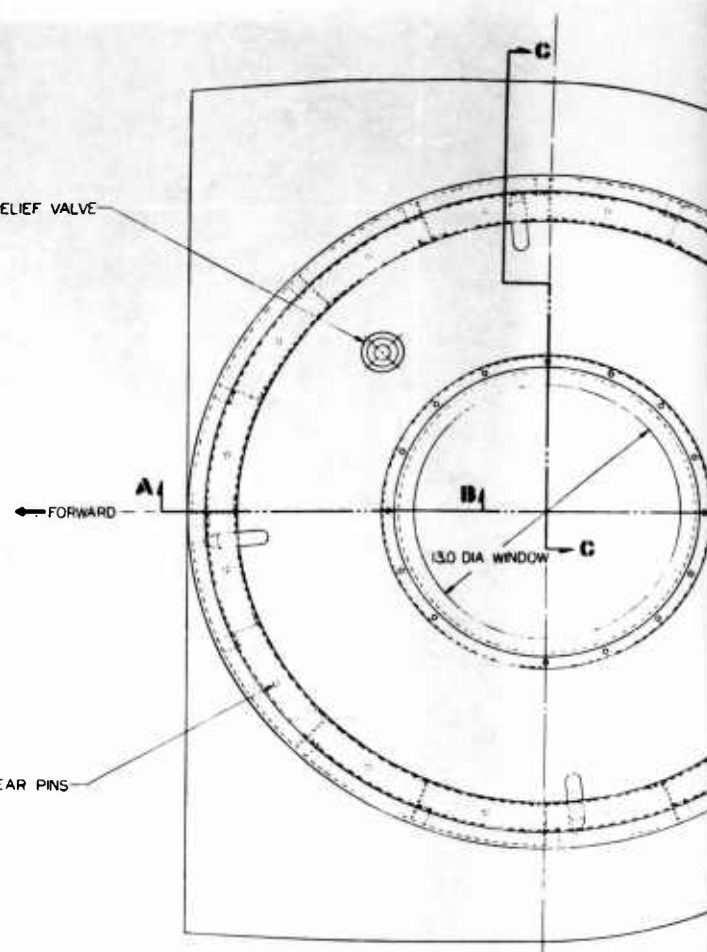

PLAN VIEW

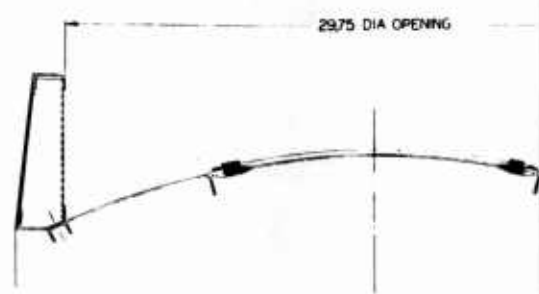
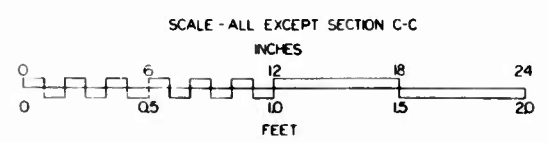

SECTION A-A

2

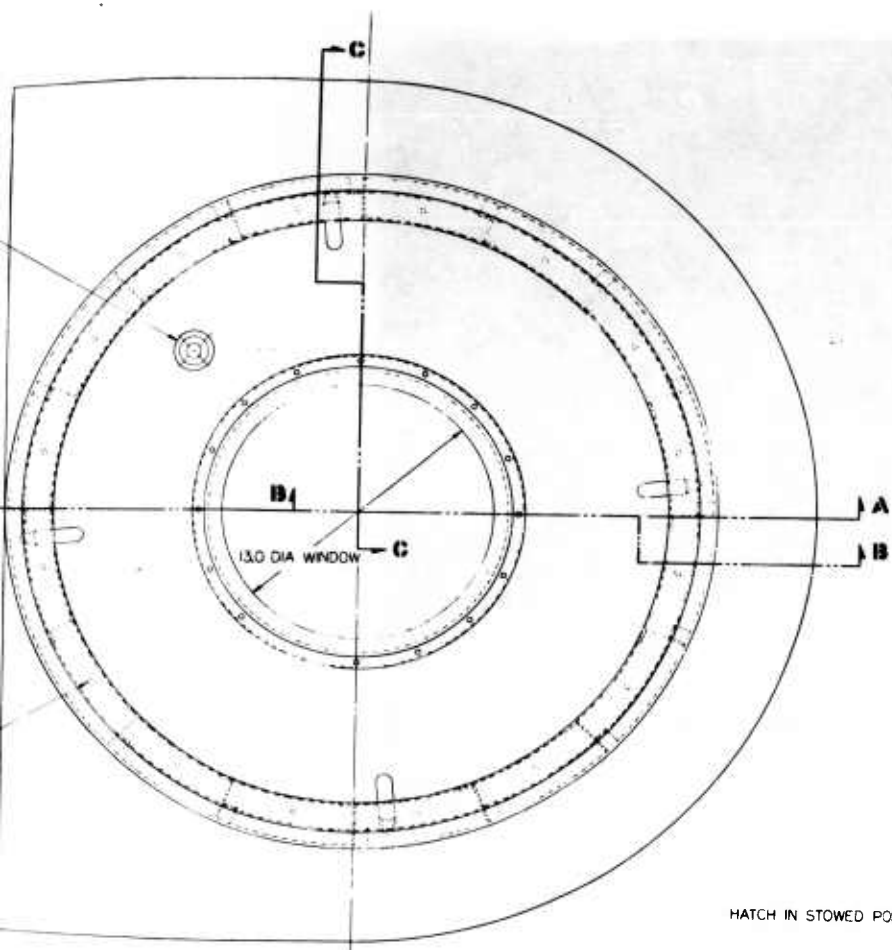

PLAN VIEW

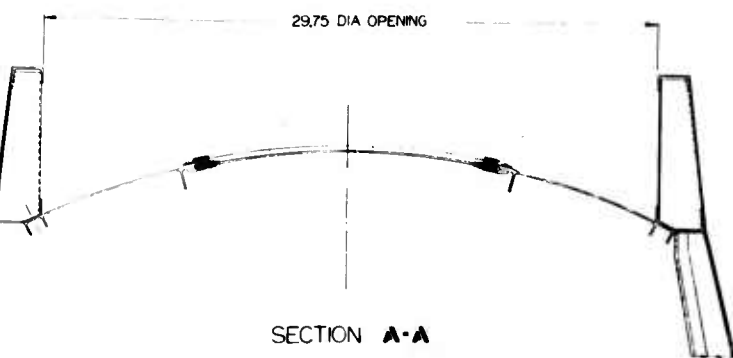

SECTION A-A

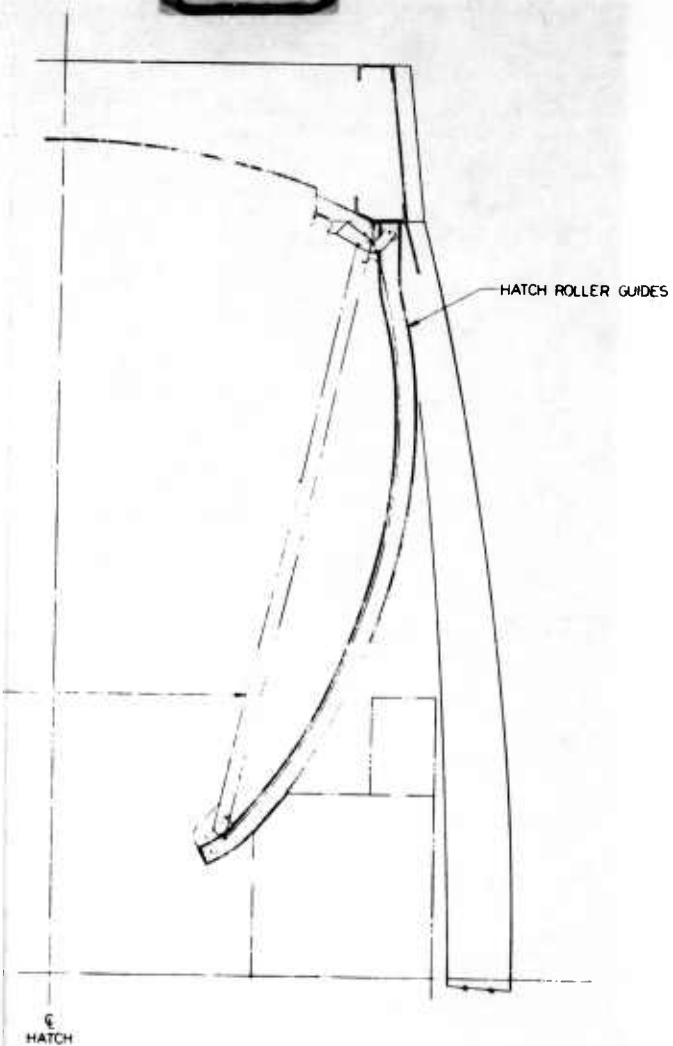

SECTION B-B

FIG. 6-8 SHUTTLE DOCKING HATCH

1

.020 5456-H343 AL ALLOY
SKIN-ALL SURFACES

5456-H343
AL ALLOY DOUBLER

SECTION E-E
FULL SIZE

.25 POLYURETHANE INSULATION

WORK HATCH RETAINER

WINDOW SEALS

SECTION D-D
FULL SIZE

30.0 CLEAR OPENING

42.1 CLEAR OPENING

WORK HATCH ROLLER GUIDE

VIEW A-A
1/4 SCALE

WORK HATCH IN STOWED POSITION

5456-H343 AL ALLOY
STRUCTURAL MEMBERS

A

WORK HATCH SHEAR PINS

WORK HATCH RETAINER -
6 PLACES

D

D

WINDOW - 2 PLACES EACH SIDE

15.5 x 30.0 WINDOW

L A

WORK HATCH RETAINER

30.0 CLEAR OPENING

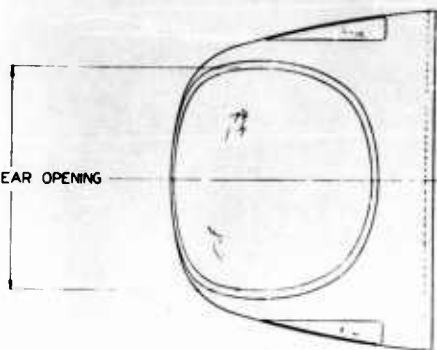

WINDOW SEALS

N D-D
SIZE

WORK HATCH SEALS

356-T6 AL ALLOY
WORK HATCH CASTING

356-T6 AL ALLOY
WINDOW FRAME CASTING

SECTION B-B
FULL SIZE

2

WORK HATCH SHEAR PINS

WORK HATCH RETAINER -
6 PLACES

WINDOW - 2 PLACES EACH SIDE

15.5 x 30.0 WINDOW

BASIC CAPSULE (REF)

ROLLER BEARING

INSULATION (REF)

SUPPORT BRACKET -
WORK HATCH ROLLER GUIDE

.080 CHEM CORE WINDOW (TYP)

.050 PLEX 55 METEOROID
BUMPER - SOLAR REFLECTIVE
COATED (TYP)

SECTION C-C
FULL SIZE

SCALE — MAIN VIEWS ONLY

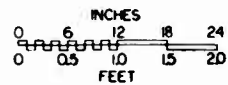

FIG. 6-9 SHUTTLE CANOPY CAPSULE

Shelter Module

An extendable shelter, Fig. 6-10, protects the worker from the hazards of meteoroids and the extremes of heat and solar glare while he makes repairs. The shelter consists of a circular housing and an expandable polyurethane impregnated stainless steel cloth cylinder, foldable on coiled spring wire such that it may be extended to encompass the work area on the target.

6.1.8 Thermal Control Provisions

Thermal control of the vehicle is maintained through a combination of active and passive type systems. Primary reliance is put upon the passive system consisting of an externally applied insulating blanket in all areas, except windows, consisting of polyurethane foam, with an external coating having suitable emissivity characteristics to attenuate extremes of solar radiant energy and the cold sink of space. To reduce heat flow through window areas, insulated curtains are provided which may be pulled across the windows during times when they are not required, especially when the vehicle is on standby at the primary.

Metabolic and equipment heat, as well as various special heating elements provided for equipment and propellants account for the major portion of the heat load. Cooling is accomplished by an environmental control system, described in Section 6-2, which uses a water boiler for heat rejection.

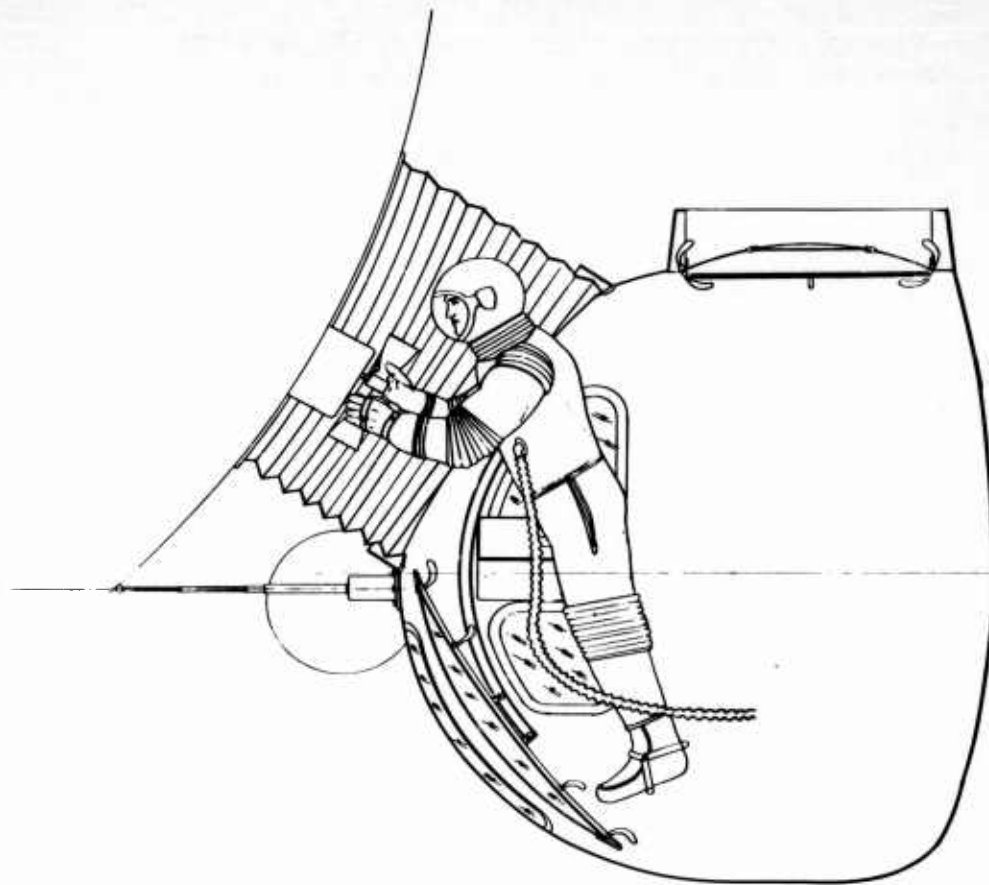

FIG. 6-10 SHUTTLE SHELTER APPLICATION

6.2 ENVIRONMENT CONTROL SYSTEM

6.2.1 Introduction

The following paragraphs present the preliminary analysis of an environmental control and life support system. The system provides atmospheric and thermal control, and water management.

The design parameters and mission profile consist briefly of the following: one-man crew, cabin atmosphere of pure oxygen at 5.0 psia, and a 10-hr mission capability (5-hr normal with a 5-hr reserve). It is also established that the crewman will be in a pressure suit throughout the mission. The system presented is based on present state-of-the-art components and concepts, low weight, growth potential and high reliability.

A survey was made of information from major environmental control system subcontractors. The major contributions were from AiResearch Manufacturing Company and Hamilton Standard who supplied information of system configuration and capabilities.

6.2.2. System Requirements

The basic problem is to provide an environmental control and life support system which will maintain an inhabitable atmosphere and thermal control for the duration of the shuttle mission. The preliminary design specifications are outlined below:

Atmospheric Supply

- a. 100% breathing oxygen
- b. Pressure: 3.5 to 5.0 psi
- c. Temperature: suit $80^{\circ}\text{F} \pm 5^{\circ}$
cabin $80^{\circ}\text{F} \pm 5^{\circ}$

- d. Relative humidity: suit 60% ±10%
cabin 30% ±10%
- e. CO₂ partial pressure: 3.8 mm Hg (max)
- f. Cabin leakage: .50 lb/hr
- g. Air flow: 12 cfm (avg), 20 cfm (max)
- h. Cabin volume: 95 cubic feet
- i. Cabin fills: 3 per mission
- j. Mission duration: 5 hrs plus 5 hrs reserve
- k. A total of two missions per week
- l. Modes of operation
 - 1. Capsule pressurized and space suited man ventilated -
either pressurized or unpressurized
 - 2. Capsule unpressurized and space suited man pressurized
and ventilated.
- m. Cabin pressure relief at 6 psi

Physiological Data

- a. Metabolic heat 450 BTU/hr (avg)
950 BTU/hr (maximum for 20 min)
- b. Metabolic O₂ consumption: .104 lb/hr (avg) .118 lb/hr (max)
- c. Metabolic CO₂ production: .116 lb/hr (avg)
- d. Water evolved by urination: .125 lb/hr
- e. Acceleration and vibration environment similar to Mercury
(no ascent or reentry heat)

Equipment and Cooling Data

- a. 28 VDC battery power supply

- b. **Equipment cooling requirements**
 - 1. **Equipment heat output: 170 BTU/hr basic vehicle load (ECS not included). Payloads requiring cooling must include necessary water.**
 - 2. **Equipment critical temperatures: 0° to 150° F**
 - 3. **Equipment cooling: cold plates**
- c. **The cabin pressurization system can be shut down during maintenance tasks, while the cabin hatch is open.**
- d. **Cabin will be capable of being repressurized to 3.5 psi in 15 sec.**
- e. **The system can be resupplied from the primary oxygen storage tanks which contain supercritical O₂ at 850 psi.**
- f. **Cabin heat load varies between -300 and +1200 BTU/hr.**
- g. **Shuttle will have provisions for being pressurized and preheated by the primary vehicle prior to departure.**
- h. **Battery temperature limits +20 to +85° F.**
- i. **Equipment and vehicle can be stored for one year attached to the primary.**

6.2.3 System Synthesis

A functional schematic of the proposed system is shown on Fig 6-11. The following paragraphs present the basic system philosophy, synthesis and reasons for subsystem selection.

6.2.3.1 Atmospheric Control

Control of the atmospheric contaminants is provided in the suit loop and consists of filter, odor and trace-contaminant remover, and carbon dioxide management. Activated carbon bed is used for odor and trace gas removal. The carbon will absorb most of the odor-causing and toxic materials; however, it will not effectively absorb contaminants such as methane, hydrazine, carbon monoxide and hydrogen sulfide. The normal build-up of these contaminants is estimated to be well within the tolerance levels. Therefore, no catalytic burner is provided.

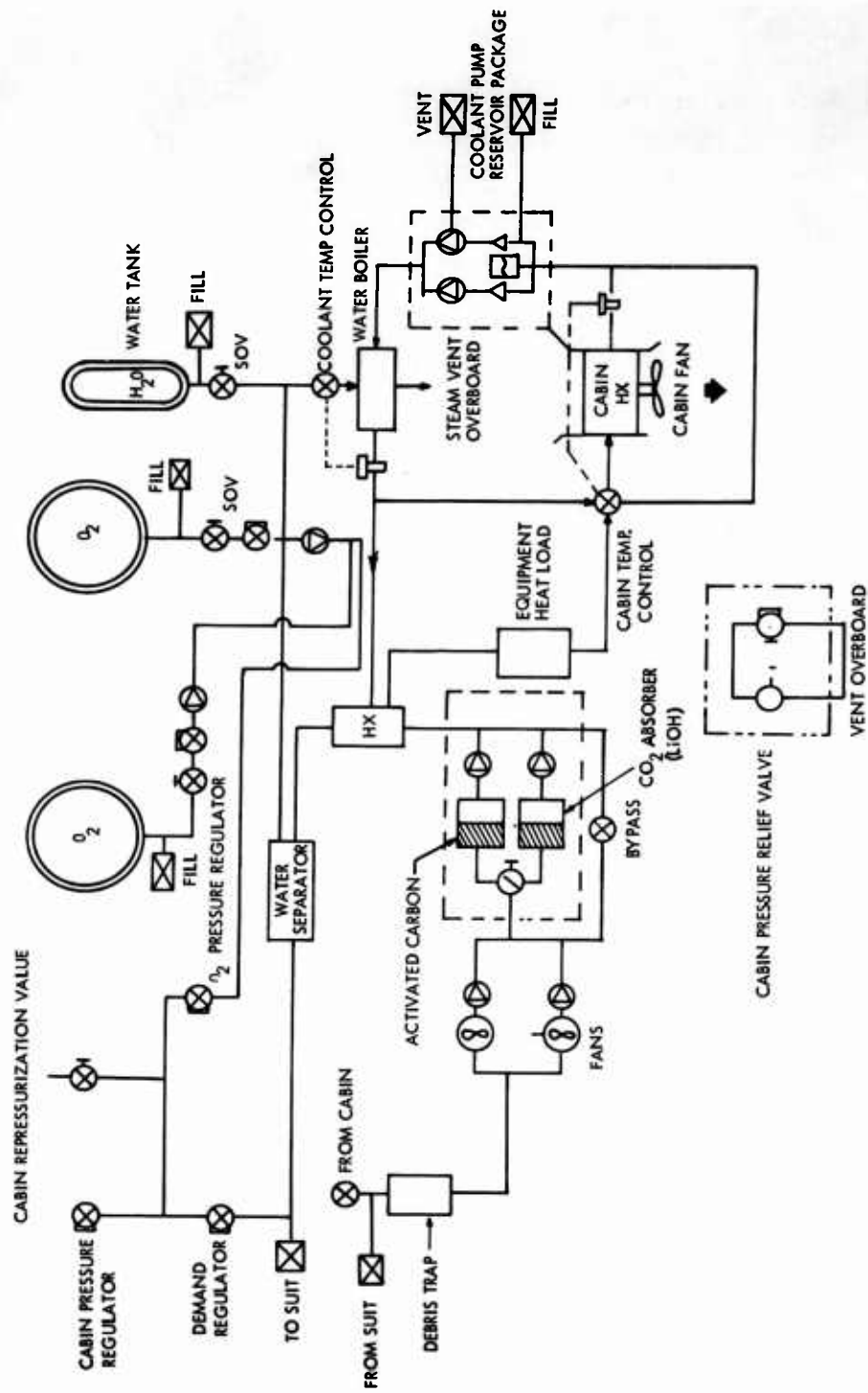

FIG. 6-11 SCHEMATIC DIAGRAM ENVIRONMENTAL CONTROL SYSTEM

The most advantageous method of CO₂ removal, considering state-of-the-art, reliability, mission time, and ease of control, is by lithium hydroxide (LiOH). Two refillable canisters are provided, of which one is redundant.

6.2.3.2 Oxygen Supply

Oxygen for repressurization, leakage makeup, and metabolic consumption is obtained from a pressurized gas bottle. This bottle is filled from supercritical storage in the space station which is assumed to be maintained at a constant pressure of 850 to 1000 psia. Flow from the space station supercritical storage is via an electric heater, a pressure regulating valve set to maintain constant pressure at the heating element, and a manual flow valve. After connection of an empty tank to the manual flow valve, the valve is opened. Supercritical gas then flows from the space station tank through the electric heater. An automatic thermostatic control ensures a constant gas temperature, shutting the heater off at 530°R. The pressure regulating valve, located between the heater and the manual stop valve prevents expansion of the gas to a reduced pressure until after the gas temperature has been raised to the bottle temperature of, nominally, 530°R. As the gas expands into the empty bottle, its pressure is momentarily lowered, but it does not enter the two-phase region because of its temperature. The bottle is fully charged when its pressure reaches the space station storage pressure. At this point, flow automatically ceases.

This system permits filling a partially full bottle without loss of the residual gas in the bottle and prevents over-filling which could produce excessive pressure as the temperature rises.

At a bottle pressure of 1000 psia and a temperature of 530°R, the volume would be about 2.5 ft³ for 14.0 lb of oxygen.

6.2.3.3 Thermal Control

Thermal control of the vehicle, crew and equipment is provided by both passive (use of insulation and selective surface coatings) and active (air/fluid

circulation system to external means). The basic philosophy is to minimize the active heat rejection penalty associated with varying vehicle orientation, and to maintain the inside wall temperatures above the dew point by passive thermal control. Active thermal control is used for maintaining temperature control of the crew, electronic equipment, and compartment. Heat is rejected from the active thermal control system by use of a water boiler.

The two methods of heat rejection considered were a water-boiler and a radiator. The radiator was eliminated due to the orientation problem, i. e., the inter-radiation between the shuttle and "work" vehicle.

During normal operation with suit ventilation operating the compartment will be maintained at 75°F by the active thermal control system. The build-up of compartment relative humidity from the influent airflow from the suit will be less than 30 percent. At this condition, the compartment dew point is 45°F. The inside wall and transparent area temperatures will be maintained above this temperature passively.

In selection of the system, it was assumed that the pressure suit was similar to the one now in development for Apollo. The temperature and humidity for various metabolic heat inputs is shown in Fig. 6-12. This shows that at the design metabolic heat rate (12 cfm and a 40°F inlet) suit condition of 75°F and 55% relative humidity will be maintained. However, at the maximum heating rate of 950 BTU/hr, the suit conditions rise considerably. Therefore, the ECS system was selected in order to provide at least 20 cfm for peak metabolic heat loads.

In order to insure thermal control of the electronic equipment during compartment decompression, liquid cooling was selected. Also, a growth potential for additional electronic equipment is insured.

6.2.4 System Description

The environmental control system for the orbital shuttle, shown schematically in Fig. 6-11, makes extensive use of state-of-the-art components. The

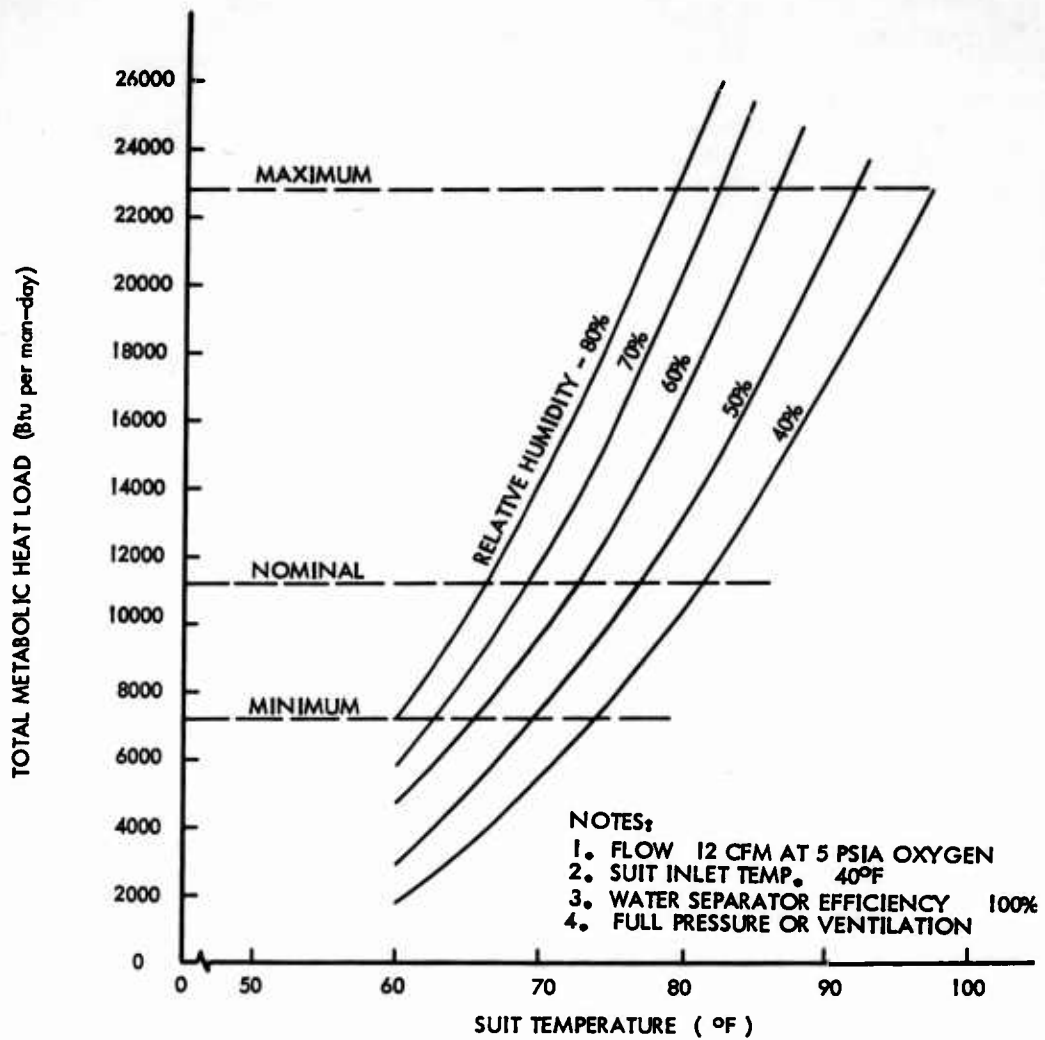

FIG. 6-12 TOTAL METABOLIC HEAT REJECTION FOR PRESSURE SUIT OPERATION

system consists of an independent air loop to the pressure suits and a compartment circulation system. The system consists of the following five subsystems:

- 1. Suit loop**
- 2. Coolant loop**
- 3. Cabin thermal control**
- 4. Water supply**
- 5. Oxygen supply and cabin pressurization**

These subsystems will be described in the following paragraphs.

6.2.4.1 Suit Loop

The suit loop provides the ventilating and breathing gas required by the man in a space suit for both the pressurized and depressurized cabin conditions. Ventilating flow is provided by redundant electric-motor-driven fans, that are supplied with a-c electrical power by static inverters. The static inverters operate at two frequencies, one for normal operation (ventilating flow = 12 cfm) and the other for the peak condition (ventilating flow = 20 cfm). Carbon dioxide removal is accomplished by a rechargeable lithium hydroxide absorber. Activated charcoal for odor removal is integrated with the lithium hydroxide canisters. Suitable filters are provided in the LiOH canisters for prevention of process particles and dust from infiltrating the system. Temperature and humidity control for the crew is provided by an air-liquid heat exchanger and a centrifugal water separator. The condensed moisture is collected and used in the water management system. Makeup oxygen is supplied by a demand regulator that maintains suit circuit pressure 2 to 3 in. of water above cabin pressure (cabin pressure = 5.0 psia) or at an absolute pressure of 3.5 psia (cabin depressurized). Temperature control in the suit circuit is performed by a valve controlling cooling flow to the suit circuit heat exchanger.

6.2.4.2 Coolant Loop

In the coolant loop, an intermediate heat transport fluid is used to transfer heat from the various sources (electronic equipment cold plate, cabin heat exchanger, and suit circuit heat exchanger) to the water boiler that provides the primary heat sink for the system. An ethelene glycol solution (water-glycol) was selected as the most appropriate transport fluid considering safety and reliability. Electric-motor driven centrifugal pumps provide circulation of the coolant through the system. The coolant reservoir, redundant pumps, check valves, filters, and fill connections are integrated into the coolant pump-reservoir package. Temperature control is accomplished by a water control valve which senses coolant outlet temperature.

6.2.4.3 Cabin Thermal Control Loop

Cabin thermal control is provided by a liquid-coolant-to-gas heat exchanger, with the cabin gas pumped through the heat exchanger by high-flow low head fans. The cabin temperature control modulates coolant flow to maintain the coolant outlet temperature from the cabin heat exchanger at a nominal 75°F.

6.2.4.4 Water Supply Subsystem

The water supply subsystem maintains the supply of water for crew drinking and heat sink utilization. A separate drinking water container is supplied for crew water. The water for the heat sink is obtained from, (1) the condensate collected from the suit circuit, and (2) stored water in a tank. A mechanical expulsion bladder is provided in the water tank for maintaining positive water expulsion at all times.

6.2.4.5 Power and Weight Summary

The total system weight is approximately 125 lb including expendables.

The breakdown is as follows:	Basic (lb)	Trainer (lb)
Fixed weight	88	64
Expendables		
Oxygen	14	11
Water	18	12
Absorbants	5	2
Total	125	89

The average power requirement for operation of the ECS is 72 watts. A summary is shown below:

<u>Item</u>	<u>Power Watts</u>	
	<u>Normal</u>	<u>Maximum</u>
Suit fan	47	80
Cabin fan	20	-
Coolant pump	5	5
Total	72	85

6.3 PROPULSION

6.3.1 System Functions and Requirements

The propulsion system for the shuttle performs two basic functions: (1) attitude control of the vehicle during all mission phases, including automatic attitude hold, and (2) translation in three directions with the maximum translation requirement in the "X" direction, (Fig. 6-1).

Propulsion system requirements are as follows:

Reaction control for translation in the X direction and pitch and yaw control

1. Number of engines: 16
2. Thrust level: 25 lb each
3. Control mode: pulse width modulation with automatic attitude hold and manual override.
4. Pulse width: Minimum - equivalent to 0.125 lb-sec impulse
Maximum - 20 min.
5. Pulse Frequency: 50 cps

Reaction control for roll and "Y" and "Z" translation

1. Number of engine: 8
2. Thrust level: 5 lb each
3. Control mode: pulse width modulation with automatic attitude hold and manual override.
4. Pulse width: Minimum - equivalent to 0.150 lb-sec impulse
Maximum - 30 sec
5. Pulse frequency: 33 cps

6.3.2 System Design

A pressure fed storable propellant system is selected for the reaction control system of the shuttle vehicle. This selection is based on the following three mission considerations: (1) control mode, (2) mission duration, and (3) response rate. Since the system is pulse-width modulated, either a liquid or hybrid system is indicated. Due to the present development status of the hybrid systems, they were not considered. A storable propellant is selected

on the basis of the vehicle standby requirement and mission life. A pressure fed system is selected because of the favorable response rate and reliability characteristics.

6.3.2.1 Propellant Selection

Nitrogen tetroxide (N_2O_4), 50 percent hydrazine, and 50 percent unsymmetrical dimethyl hydrazine propellants are chosen for the shuttle vehicle. This selection is based on the weight advantage, as shown in Table 6-1, of the bi-propellant systems over the cold and hot gas monopropellants and the projected advantage in developmental and operational experience of the N_2O_4 /Aerozine 50 combination expected by the 1965 time period. Toxicity and handling problems are comparable to other systems.

6.3.2.2 Engine Characteristics

Radiation cooled thrust chambers are selected for the reaction control engines. Ablation cooled engines were discarded due to the long life requirement (one year), and regeneratively cooled engines were discarded due to the rapid response rates required. The requirements quoted under section 6.4.1 are considered within the state of the art for radiation cooled chambers and will provide the most reliable engine available in the 1965 time period. The only requirement which has not been proven to date is the 5 millisecond equivalent square wave pulse width on the 25-lb thrust engines. An engine using this pulse width is presently in the development stage and is expected to be operational by 1965.

The following characteristics are selected for the 25-lb thrust engines:

- | | |
|------------------------------------|-----------------|
| 1. Chamber pressure | 90 psia |
| 2. Mixture ratio | 1.65 |
| 3. Expansion ratio | 40 |
| 4. Characteristic length (L^*) | 11 |
| 5. Nozzle shape | 80 percent bell |

Table 6-1

PROPELLANT COMPARISON

Propellant	Storability	Toxicity	Estimated Performance (vacuum) (sec.)	Comb. Temp. (°F)	Exhaust Toxicity	Total Impulse = 85000 lb-sec Propellant Weight (lb)	Propellant Volume (cu. ft.)
Hydrogen Nitrogen	Good at 70° F	None	240	70	None	360	260 @ 4000 psia
	Good at 70° F	None	64	70	None	1320	67 @ 4000 psia
<u>COLD GAS MONOPROPELLANTS</u>							
90% Hydrogen Peroxide Hydrazine Nitromethane Monomethyl Hydrazine	Good	Medium	184	1380	None	610	7.1
	Good	High	250	1125	None	450	7.2
	Good	Medium	250	3950	None	425	6.0
	Good	High	250	1600	None	450	8.2
<u>HOT GAS MONOPROPELLANTS</u>							
N ₂ O ₄ -50-50 UDMH/N ₂ H ₄ MON-77% N ₂ O ₄ MMH-85% N ₂ H ₄	Good	High	315	5400	Low	270	3.6
	Good	High	320	5800	Low	265	3.9
<u>BI-PROPELLANTS</u>							

The characteristics selected for the 5-lb thrust engines are:

- | | |
|------------------------------------|-----------------|
| 1. Chamber pressure | 90 psia |
| 2. Mixture ratio | 1.65 |
| 3. Expansion ratio | 40 |
| 4. Characteristic length (L^*) | 12 |
| 5. Nozzle shape | 80 percent bell |

The chamber pressure and geometry are selected as the best compromise for developed hardware giving acceptable performance, weight, and size. The mixture ratio chosen permits the fuel and oxidizer tanks to be equal in size. Also, operation at this mixture ratio reduces the combustion temperature below that obtained for optimum specific impulse thus increasing chamber life. The degradation of specific impulse due to the off-optimum mixture ratio is less than two percent and results in a very small weight penalty. The specific impulse performance of the engines with these parameters is as follows:

25 lb-thrust engine	Steady state	-	I_{sp}	300 sec
	Min. pulse	-	I_{sp}	230 sec
5 lb-thrust engine	Steady state	-	I_{sp}	300 sec
	Min. pulse	-	I_{sp}	260 sec

6.3.2.3 Pressurant Selection

Nitrogen gas stored at 1500 psia is selected for pressurizing the propellant tanks. Use of nitrogen rather than helium, although resulting in a weight penalty, is chosen because of the leakage problems associated with helium.

6.3.2.4 Feed System

The feed system is shown schematically in Fig. 6-13. The propellant is distributed equally in two sets of tanks (which maintain vehicle c. g. control) which are located as shown in Fig. 6-6. Based on the specific impulse values, duty cycles, propellant distribution to thrusters, and the total impulse of 73, 650 lb-sec, the total usable propellant required is 257 lb.

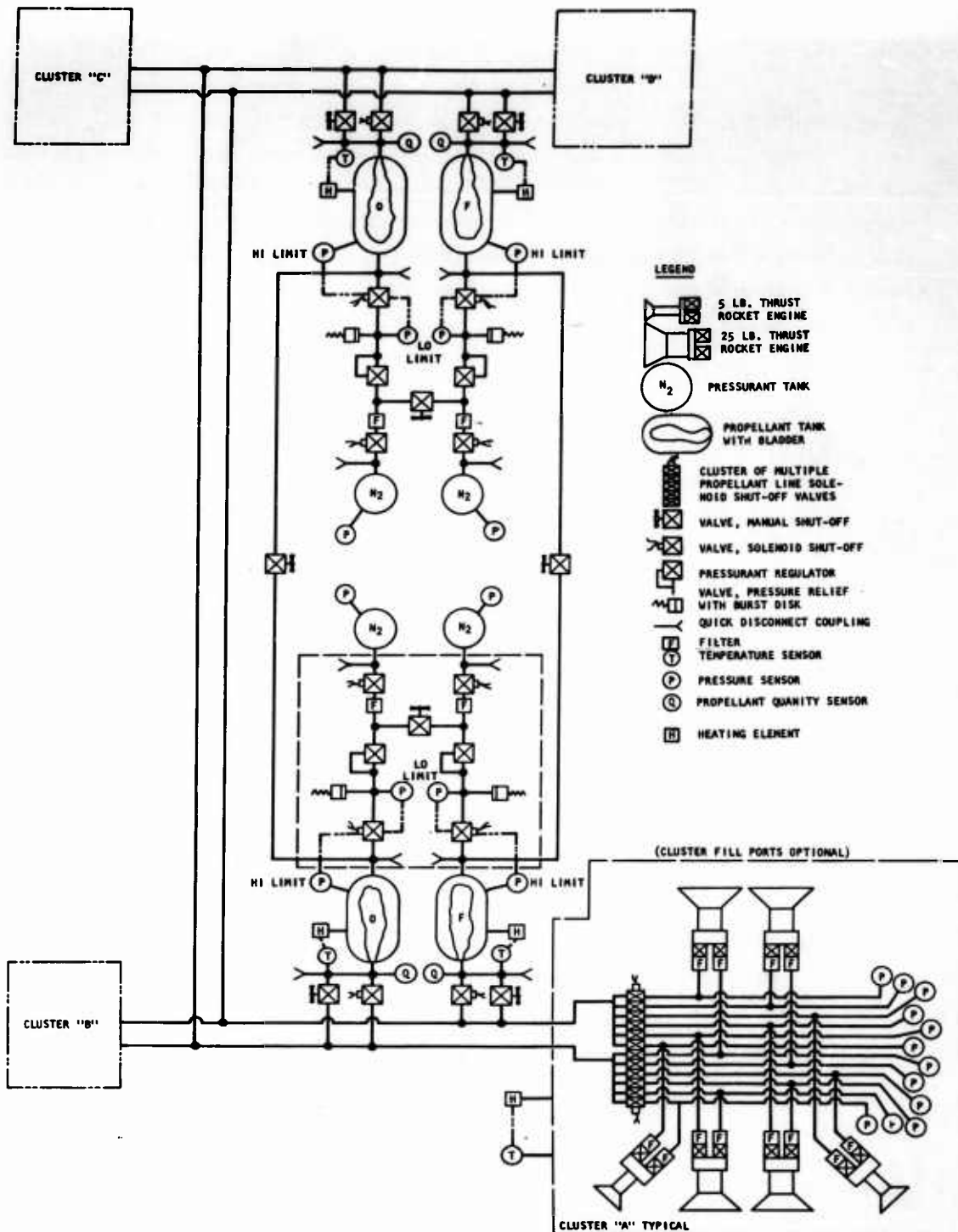

FIG. 6-13 SHUTTLE ENGINE CLUSTER (from Marquardt Corp., Van Nuys, Calif.)

Approximately 5 percent surplus propellant is added to account for system unusables and expulsion efficiency. Leakage is considered negligible during the 5-hr mission time. This gives a total propellant supply of 270 lb. Since the propellant is divided equally between two sets of tanks, a fully charged tank contains either 83 pounds of oxidizer or 52 pounds of fuel. Heaters are provided at the propellant tanks to maintain acceptable temperature limits within the tanks.

The feed system consists of two pressure fed liquid bi-propellant supply modules commonly feeding twenty-four engines. Each supply module consists of an oxidizer tank, a fuel tank, and two nitrogen pressurization systems which affords some redundancy. A single nitrogen system supplies pressurized gas through a filter and a pressure regulator to an individual propellant tank. The propellant is expelled by means of a collapsing bladder and routed to each of the engines through its injector valves. To protect these injector valves, a filter is provided for each engine upstream of the valves.

Each pressurization system consists of a nitrogen supply tank, solenoid shutoff valve, filter/regulator, pressure relief valve, and high/low pressure controlled solenoid shutoff valve. Manual shut-off valves allow transfer of unregulated pressurant gas between nitrogen systems within a module at a point just upstream of the pressure regulator. Regulated pressure may also be transferred between systems from module to module through the use of manual shutoff valves. Each nitrogen tank is sized to contain 1-1/3 times the nominal gas supply required so that mission requirements may be met by any three of the four available tanks. The fuel and oxidizer systems are separate except during this emergency mode of operation.

Each propellant system consists of a tank with a double bladder type positive expulsion system. A manual and a solenoid valve connected in parallel at the outlet provide a redundant shutoff-open capability.

Each engine cluster is connected to a single fuel and a single oxidizer line. Solenoid operated shutoff valves in each engine propellant lines allow

isolation of any single engine or group of engines in the event of propellant valve failure. This approach permits the system to be operated under various combinations of component failure and thus enhances overall system reliability.

6.3.3 PROPELLANT TANKS

The following describes propellant tank design as proposed by Marquardt Corporation.

6.3.3.1 Sizing

Based on an effective I_{sp} of 287.4 sec and a total impulse requirement of 73,650 lb-sec, the total usable propellant required is 256.25 lb. Using an engine mixture ratio equivalent to the ratio of propellant specific gravities (O/F = 1.64) permits equal volume tanks for fuel and oxidizer.

Total propellant supply is divided between two sets of tanks. Therefore, a single oxidizer tank should contain 0.79 lb of usable propellant; a fuel tank, 49.5 lb. Approximately 5 percent surplus propellant is required to compensate for the quantity which is unusable due to tank and bladder expulsion efficiency and line volume. A fully charged propellant tank then must contain 83 lb of oxidizer or 52 lb of fuel; a fully charged system (4 tanks) contains 270 lbs of propellant.

At 70°F, the propellant volume is 1610 cu in. If 5 percent gas ullage is allowed, to compensate for thermal cycling, the internal tank volume required is approximately 1700 cu in. Fig. 6-14 shows a configuration which has been selected to provide the required volume.

6.3.3.2 Design Considerations

Each propellant tank as shown in Fig. 6-14 comprises four major sub-elements: (1) tank structural shell, (2) double bladder assembly, (3) expulsion aid (standpipe), and (4) tank closure.

Basic propellant tank configuration comprises a cylindrical section girth welded to two hemispherical end caps. A pair of permanently bonded evacuated teflon bladders contain the propellants. Propellant is expelled by admitting nitrogen gas to the exterior surface of the bladder, collapsing the

bladders, thus forcing the propellant through the standpipe and out through the discharge end. At the gas inlet, a cylindrical boss is provided to support a spherical ball bushing. At the propellant end, a mount surface is provided which will permit mounting of the tank on as many as four spherical rod bearings. Thus the tank is firmly supported. The propellant discharge end will be restrained in a direction parallel to the tank axis; the gas end will then be free to slide on the outside diameter of the ball bushing. Vehicle deflections do not, therefore, load the tank and increase stresses. Further, use of a double ball end arrangement such as this permits the tank to align itself without imposition of externally applied bending loads.

Bladders will be made from laminated teflon formed via the spray dispersion process. Two bladders will be used, each of 0.007 total thickness with 0.0035 TFE and 0.0035 FEP. Bladders will be assembled, one within the other, the space between the two will be evacuated and the bladders will be heat sealed to each other to form an integral bladder assembly. Three basic bladder configurations with respect to cross sectional shape are shown. The first, is a normal full cylinder. The second a two lobe design. The third a three lobe design. Since correct bladder function is an exercise in elastic buckling, the lobe designs have been selected to provide the bladder with built-in buckling modes. It is expected that use of such configurations will increase the number of cycles prior to failure by eliminating random three corner folds and the attendant high local stresses associated with these folds.

Two separate bladder closure techniques are shown. The first utilizes clamping of the bladder between a pair of annular serrations with a redundant exterior O-ring seal. The second, which should prove to be more reliable, envisions heat sealing of the bladder pair to a common closure cap. At the nitrogen inlet end, the same sealing procedures will be evaluated, along with a third that provides for elimination of the hole in the bladder used to permit passage of the clamping components. End clamp components shown are designed to provide a continuous clamping load on the bladder, accomplished by designing the outside closure element as a belleville washer. This piece is

also grooved axially and radially to permit uniformly distributed flow of nitrogen pressurizing gas. The surface that carries the annular groove also will slide axially in the tank to provide for differential deflection between standpipe and tank shell, while simultaneously locating the standpipe in the correct position. The standpipe in turn, restrains the bladder from large deflections during transverse load conditions.

6.3.3.3 Structural Considerations

The tank material is of 6AL-4V titanium alloy, heat treated and aged. This material was chosen on the basis of high strength to weight, good weldability, fuel and oxidizer compatibility, corrosion resistance, and sufficient notch toughness for pressure vessel design and fabrication.

Critical stress conditions for this type of tank are: bending due to lateral accelerations, and buckling due to filling under evacuated conditions. The trunnion areas on the spherical ends are critical for lateral loads on both ends and axial loads on the fixed end.

Investigation of the required thickness for the cylindrical portion of the shell covered basic pressure stresses, bending stress, and buckling stresses. Based on an operating pressure of 185 psig (370 psig burst), the pressure stresses are not critical.

Buckling allowables on the cylindrical portion were calculated using the method of NASA TN3783. The effects of pressure stabilization were not considered in calculating the buckling allowables. If pressure stabilization is permitted, considerable weight saving may be effected.

6.3.4 PRESSURANT TANK

The following describes pressurant tank design as proposed by Marquardt Corporation.

6.3.4.1 Sizing

The nitrogen pressurant tanks as shown in Fig. 6-15 are designed with a mean shell diameter of 9.04 inches. This dimension was selected for two reasons: first, since this diameter is identical to the diameter of the propellant

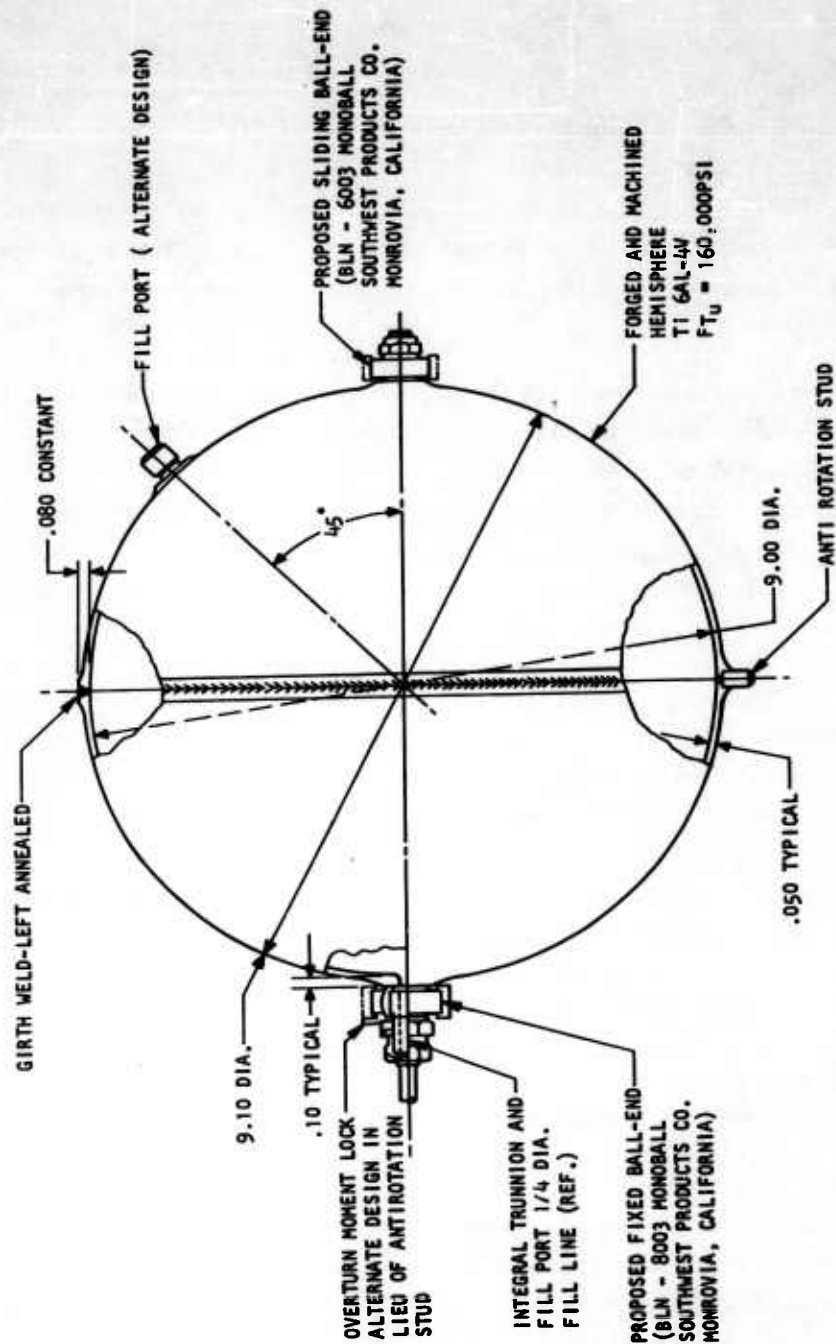

FIG. 6-15 SHUTTLE PRESSURANT TANK (from Marquardt Corp., Van Nuys Calif.)

tank and hemispheres, common tooling can be used for many of the fabrication operations for both tank configurations; second, the relatively large size of this tank permits the charging pressure to be substantially lower than would normally be available when charging is done on the ground. Thus, the equipment required for in-space servicing and recharge of the shuttle vehicle propulsion system can be more compact than that which is necessary to obtain higher charging pressures.

The tank is designed to provide sufficient pressurant gas to expel 1-1/3 times the propellant contained in each propellant tank, thereby complete propellant expulsion can be performed if one pressurant tank malfunctions. The pressurant will be charged at 1520 psig and will decay to 700 psig at complete expulsion of a single propellant tank (if 1-1/3 propellant tanks are expelled the pressurant tank decays to 450 psig). Fig. 6-15 shows the proposed pressurant tank configuration.

6.3.4.2 Design Considerations

The basic pressurant tank configuration is formed by welding the two hemispherical end caps together at mid-section. The tanks are simply supported by fixed and sliding trunnions and spherical bushings, as are the propellant tanks. The assembly consists of two forgings welded at mid-section. This is designed to provide for a minimum of welding and a maximum of structural integrity, thereby providing a high inherent reliability level. The basic material will be 6 aluminum- 5 vanadium titanium alloy, heat-treated to the 160,000 psi minimum UTS condition.

The inlet port passes coaxially through the fixed trunnion mount however, an alternate approach is presented in the drawing.

6.3.4.3 Structural Considerations

The tank material is 6AL-4V titanium alloy, heat treated and aged. This material was chosen on the basis of high strength to weight, good weldability, corrosion resistance and sufficient notch toughness for pressure vessel design and fabrication.

The critical stress conditions for this type of tank are: burst pressure in the spherical shell and lateral initial loading on the trunnions, axial on the fixed trunnion. The design burst pressure is 3050 psig.

6.3.5 Operational Considerations

The reaction control system is designed such that flight monitoring is at a minimum. Pressure sensing in the nitrogen tanks and within the propellant tanks provide indication of feed pressure degradation. Propellant quantity sensors and propellant temperature indicators inform the pilot of propellant remaining, a leakage of propellant, or a possible tank insulation breakdown. Engine operation indication is not necessary since this failure is easily detected by vehicle dynamics, and subsequent visual observation.

In addition to the sensing equipment needed for inflight monitoring, pressure transducers in the propellant lines contained within the engine clusters are utilized for pre-flight system check-out. These transducers may be checked individually by a switching circuit to detect system malfunction between the tanks and the engines. Other check-out requirements such as the position of the manual shut-off valves may be checked visually.

Flight actuation of the system is accomplished by opening the shut-off valve just downstream of the nitrogen tanks. This completely arms the system which is fully fueled and charged in the standby condition. When this valve is activated all pressure levels may be checked and the system declared in either a "go" or "no go" condition.

Resupply of the propellants and pressurant may be accomplished in two ways. The system may be refilled through the fill and vent connections provided on the tanks if the propellant tank bladders are undamaged and no system leaks are detected, or as an alternate, the propellant tanks, pressurant tanks, and associated plumbing, which are built up in modular form, may be replaced by a charged module.

All four engines clusters are identical and are designed primarily for replacement of the entire module in the event of a component failure within the module. The defective cluster may then be repaired and used as a replacement at a later date.

6.3.6 Reliability Considerations

In addition to utilizing redundant components to improve the reaction control system reliability, several features are incorporated in the system to enhance mission reliability. These include: (1) nitrogen pressurant redundancy, (2) separate N₂ tanks for fuel oxidizer, (3) redundant control modes, (4) flight monitoring, and (5) manual backup wherever possible. Also, the module concept has been employed in the feed system and engine clusters to reduce system maintenance complexity.

6.4 STABILITY AND CONTROL SYSTEM

6.4.1 Design Requirement

The basic design requirements for the stability and control system are formulated from (1) Gemini control criteria based on human factors, (2) response rates required to perform docking and attaching maneuvers, and (3) practical hardware considerations.

For compatibility with the Gemini pilot proficiency margins the following response criteria are established:

- a. Maximum angular acceleration, 20 deg/sec^2
- b. Minimum angular acceleration, 0.4 deg/sec^2
- c. Maximum angular rate, 20 deg/sec
- d. Minimum angular rate, 0.5 deg/sec

The attitude control accuracies required for shuttle operation are:

Coast attitude $\pm 10 \text{ deg}$

Powered flight $\pm 1 \text{ deg}$

To compensate for a variable c.g., the eight main thrust jets are so modulated that the resultant force vector passes through the center of gravity.

The propulsion system is comprised of sixteen 25-lb jets and eight 5-lb jets. These jets are pulse width modulated with a minimum pulse width of 5 milliseconds and 30 milliseconds respectively. With this combination of thrust and firing time, the minimum angular rate of 0.5 deg/sec is achieved.

6.4.2 Operation

Redundant main reaction jets are selected as a means of controlling the shuttle translation and angular rates. The jets are energized through a mode logic matrix by an electronics control assembly for normal operation and by direct inputs from manual controllers for emergency operation. Figure 6-16 diagrams the location and orientation of the propulsion jets

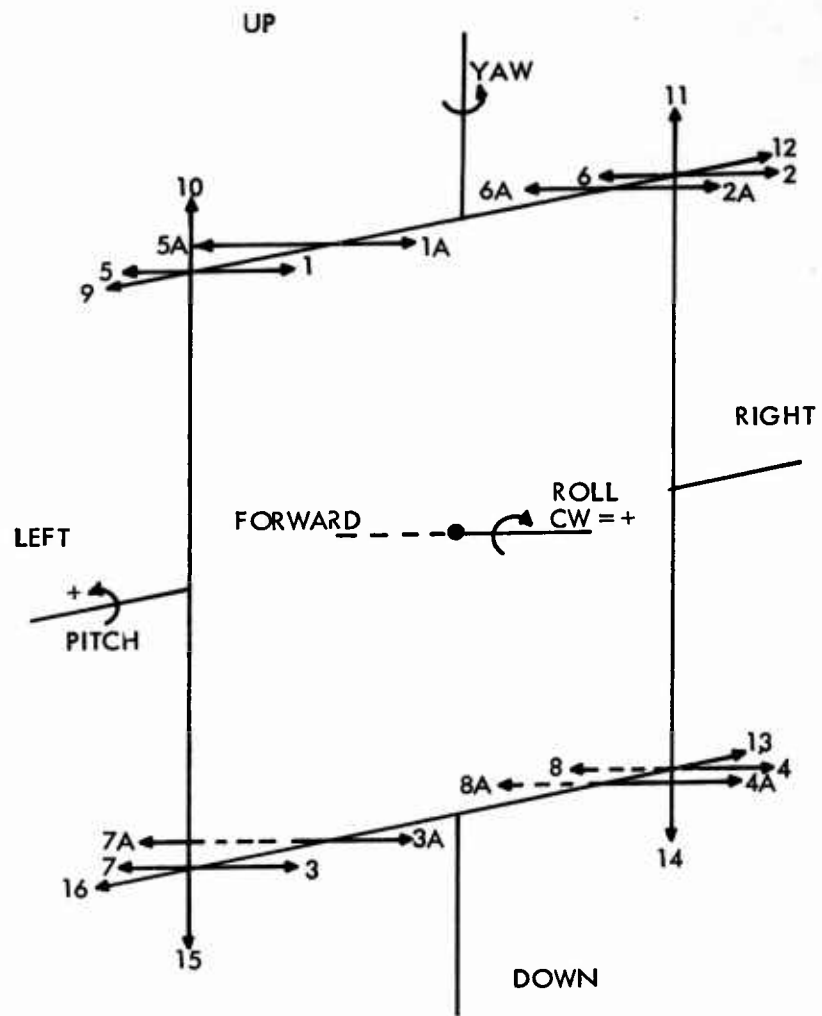

FIG. 6-16 PROPULSION JET ALLOCATION AND ORIENTATION

The 25 lb jets are used in redundant pairs for forward and reverse translation as well as pitch and yaw attitude control. Automatic attitude hold is used during translation to counteract thrust on jets producing disturbing moments. This allows the thrust line to move within the vehicle envelope to accommodate c.g. variations. Figure 6-17 diagrams this part of the control system.

The 5-lb jets are used for roll control and lateral and vertical translation. Lateral translation and roll attitude are controlled by the same jets as shown in Fig. 6-18. Vertical translation is provided by four 5-lb jets which also provide an alternate roll mode, see Fig. 6-19.

6.4.3 Control Methods

The pilot introduces all command signals into the stability and control system manually through two controllers. Translation is controlled through a two-axis controller with a thumb-operated switch for vertical maneuvering. A manually set velocity increment timer is used when the applied ΔV is critical. A trigger on the controller provides for single minimum impulse maneuvering when desirable. Fig. 6-20 diagrams the guidance and control system.

Rotation is controlled through a 3-axis controller with wrist action for rotational maneuvering. A single impulse trigger is also provided on this controller.

Translation maneuvers are performed by acceleration control. This eliminates the requirement for accelerometers. The jets are modulated with on-time proportional-to-controller displacement.

Rotation maneuvers are performed by rate control. Command signals are summed directly with rate feedback from rate gyros. Resulting error signals are used to command operation of the appropriate jets through the logic matrix. Gyros are torqued to the commanded body attitude by the vehicle rates. The new attitude will automatically be retained at the end of the command by virtue of the essentially zero rates.

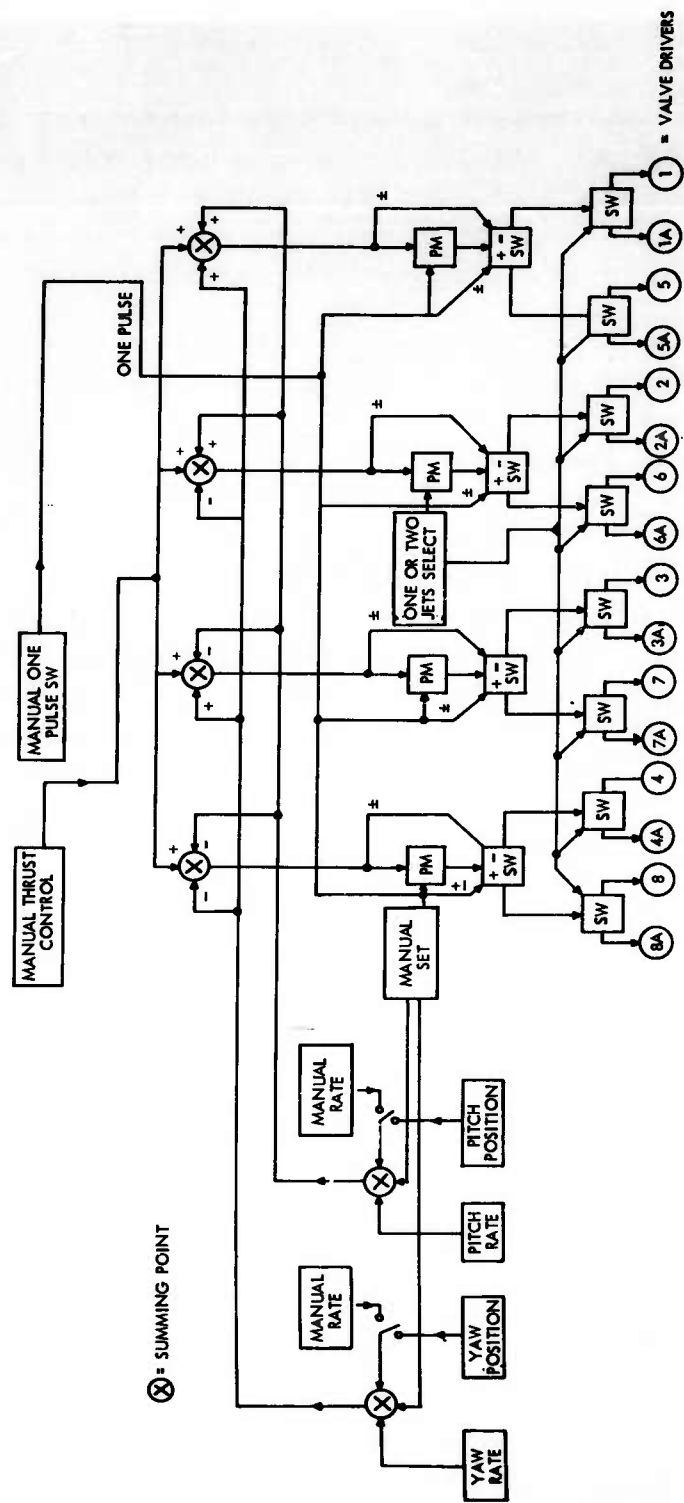

FIG. 6-17 SCHEMATIC - MAIN THRUST PITCH AND YAW CONTROL

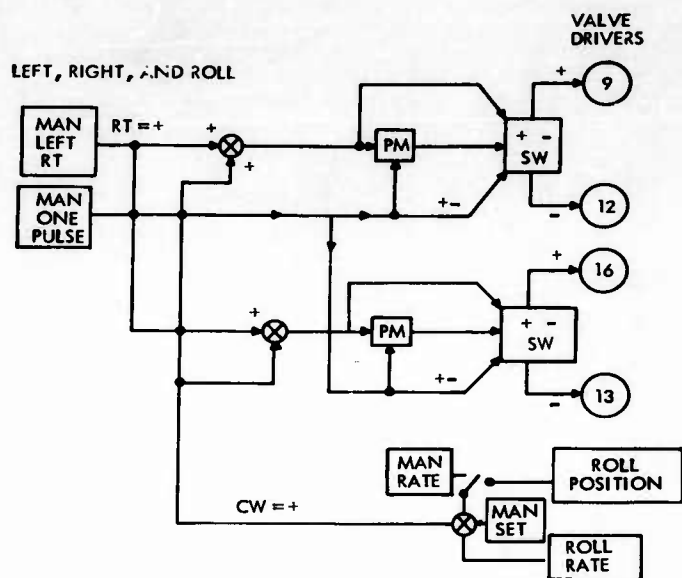

FIG. 6-18 SCHEMATIC - LATERAL TRANSLATION AND ROLL

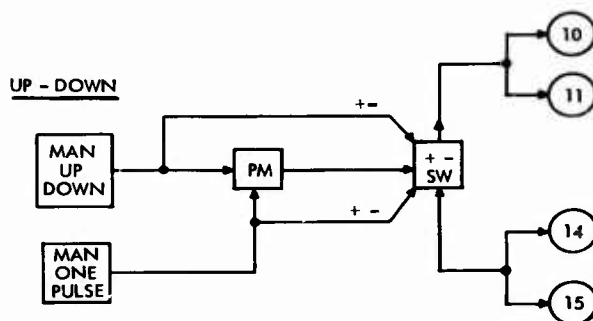

FIG. 6-19 SCHEMATIC - VERTICAL TRANSLATION AND ROLL CONTROL

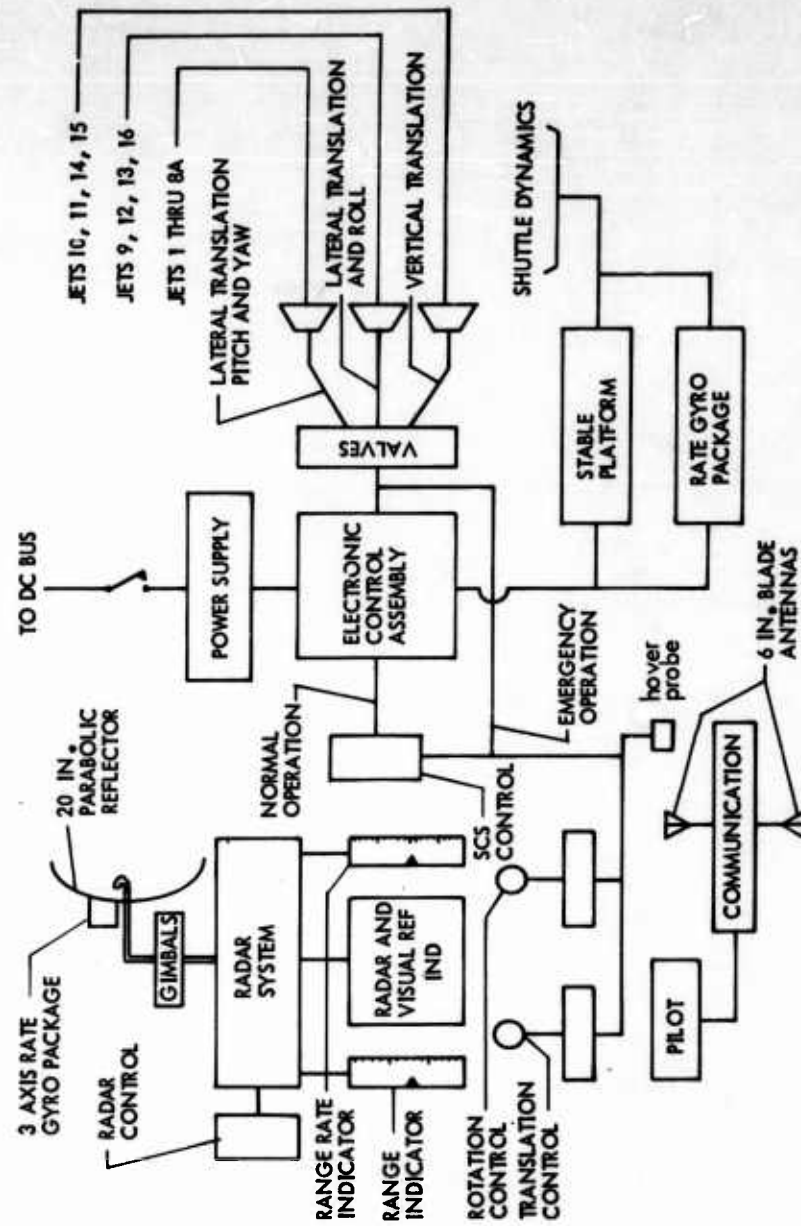

FIG. 6-20 GUIDANCE AND CONTROL BLOCK DIAGRAM

In the event of system malfunction, the pilot can command direct, on-off operation of the jets. Emergency operation is activated from the control panel and signals are imposed directly on auxiliary solenoids of each jet.

6.4.4 System Components

Following is a description of the major components of the stability and control system.

Attitude Reference Package

The ARP is a stabilized platform consisting of three gyroscopes with four gimbals and associated electronics. These gyros will achieve a high degree of angular freedom with a permanent magnet torquer capable of accurate, rapid torquing rates. Temperature is maintained by controlled heating of the mounting block. A manually adjusted control is provided to adjust the gyro null position.

Rate Gyro Package - This consists of three miniature orthogonally mounted strap down rate gyros and associated circuitry. Temperature is maintained by conduction cooling to a cold plate mounting. No heater power is required.

Electronic Control Assembly - This package acts as a summing function for all components of the system. It contains summing networks, amplifiers, pulse shapers, jet pulsing system, switches and valve drivers. It also contains switching circuitry for mode change commands from the control panel. The pulse modulator is designed to operate at a fixed frequency of 30 cps with an on-time proportional to input voltage. A separate input provides for single impulse thrusting. Solid state switches turn to select the operation of one or the other or both jets depending on the sense of signal received.

Power Supply - A solid state inverter provides for the various ac voltages required.

Hover Probe - This is a hinged telescopic device which senses shuttle-target relationship for hover operations.

System Physical and Electrical Characteristics

Items	Weight (lb)	Volume (cu in.)	Average Power (watts)
Attitude Reference Package	10	150	35
Rate Gyro Package	5	110	10
Electronic Control Assembly	10	300	15
Power Supply	5	125	25

The attitude reference package is used only when the hover and automatic attitude control modes are desired; it is not included for the training mission.

6.5 NAVIGATION AND GUIDANCE

The need for orbital day and night operations extending to 20-mi ranges dictates the requirement for target angle tracking and ranging aids. Related analyses further determined that under good visibility conditions, visual aids are useful for propellant conservation and reduction of control system response requirements. There is considerable uncertainty regarding the pilot's ability to visually judge range and range rate accurately enough to perform the docking maneuver. Therefore, such parameters are measured and presented on indicators. The navigation and guidance system recommended for the shuttle is comprised of:

1. a radar system
2. a visual homing reference (fixed reticle)
3. a range and range rate indicator

A description of these basic units is given below accompanied by a tabulation of their essential characteristics.

Radar System

In section 4.6.3, Fig. 4-27 the trajectory variables are given which must be measured and presented to the pilot for performing a rendezvous with proportional navigation. Table 4-4 indicates the accuracy with which these measurements must be made to effect a safe rendezvous. Figure 6-21 is a schematic of the navigation system formulated on the basis of the information derived in section 4.6.3.

The basic characteristics of a radar that will satisfy the guidance requirements of the shuttle for the established 6-mi range capability are as follows.

Antenna

A 20-in parabolic reflector is provided with a two-degree-of-freedom gimbal aligned with shuttle body axes. A three-axis rate gyro package is mounted on the antenna to measure the angular velocity of the antenna with respect to inertial coordinates.

Transmitter

A coherent phase modulated continuous wave (CW) transmitter is installed operating at x-band, with an effective radiated power of 10 milliwatts.

Receiver

A phase lock receiver is used for target detection and range measurement. Range data is coupled with the sight-line direction data to produce a range vector which is displayed on a range indicator. Range rate information is derived by Doppler extraction from the signal and displayed directly on a range rate indicator.

The difference in inertial velocity of shuttle and target is evaluated in terms of a line-of-sight component and a normal-to-sight line component. This is displayed in terms of velocity components along shuttle fixed axes.

Displays

The range and range rate data is presented on conventional aircraft type instruments.

Inertial velocity and angular information is displayed on an instrument similar to that depicted in Fig. 6-22. Since it is desirable to have a visual reference when radar is not being used, a simple crosshair reticle on the display serves to assist the pilot in gauging the target's apparent motion. When radar is required, it is not desirable to have different types of displays, therefore, the visual reference and radar display are integrated. In the radar mode, two mutually orthogonal cursors are slaved to the antenna gimbals. The pilot controls the shuttle so as to superimpose the cursors on the reference reticle. The lower limit line is adjustable to orbit altitude so that when it is maintained on the Earth's apparent horizon the main reference line is on a true local horizontal. The upper and lower limit lines are displaced equally from the reference line to provide for a maneuvering limit cycle boundary. For example, when the SMU guidance mode is employed the limit lines are displaced ± 10 deg

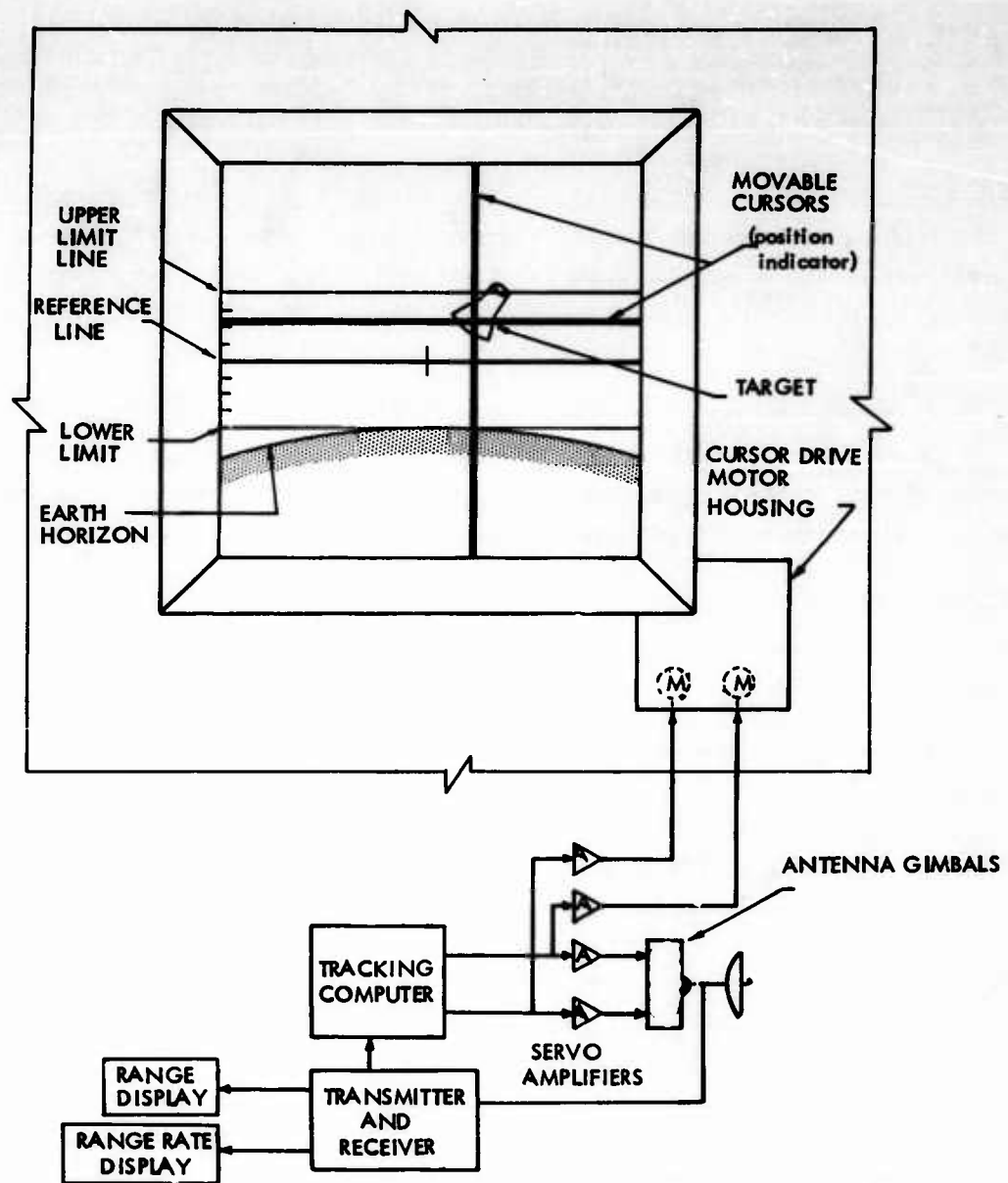

FIG. 6-22 SHUTTLE RADAR AND VISUAL DISPLAY

from local horizontal. The pilot applies corrective thrust as the target alternately reaches the limit lines. As the distance becomes smaller, the target appears to reach the limits more frequently; thus continually nulling the sight line angular rate.

Weight and Power

The weight of the antenna, radar system and displays is estimated to be 20 pounds and requires about 25 watts of electrical powers.

Estimated Performance

- a. Single-look detection probability is 90 percent at 6 miles against a 0.3 square meter target which is equivalent to a transit satellite.
- b. Range accuracy at distances greater than 1 mile is 0.05 percent of measured range. At lesser ranges, accuracies are as follows:
 - at 1 mi \pm 20 ft
 - at 50 ft \pm 5 ft
 - at 10 ft \pm 2.5 ft
- c. Range rate accuracy is 0.5 ft/sec independent of range
- d. Gyros for angular data can tolerate a drift rate of about 1 deg/hr

6.6 ELECTRICAL POWER SYSTEM

The criteria established for the electrical power system design are:

- a. Complete mission performance independent of the primary vehicle, with resupply or recharge capability after mission completion.
- b. Minimum extra-vehicular appendages
- c. Long term orbital life with high reliability
- d. One-man maximum mission of 5-hr duration with an additional 5-hr contingency for emergency.

6.6.1 Design Consideration

In section 3.3.3, electrical power load profiles indicate the requirements for various missions. For a design basis, the maximum 5-hr mission is used. Total average power requirements for this mission are 240 watts, with a peak power requirement of 350 watts. The additional 5-hr contingency, set forth by the design criteria, establishes the requirement for a 100 percent power reserve.

For complex space vehicles, the electrical power system is usually designed to serve as a switchboard to provide all requested power and switching functions to the utilization equipment. However, due to the simplicity of the shuttle subsystems and to accommodate a variety of systems for different missions, the design approach is necessarily altered. Each subsystem obtains its power from a common dc bus, and where power of special characteristics (such as 400 cycle ac for guidance components) is required, the generation, regulation, and distribution is accomplished within the subsystem itself.

Studies made to determine the most suitable electrical power system for the shuttle are reflected in Fig. 6-23. For the power level required to satisfy a 5-hr mission, it can be seen that batteries are the only principal contender. Even with the requirement for an additional 5-hr contingency, fuel cells and the cryocycle can be discounted on the basis of cryogenic storage and the attendant complexity.

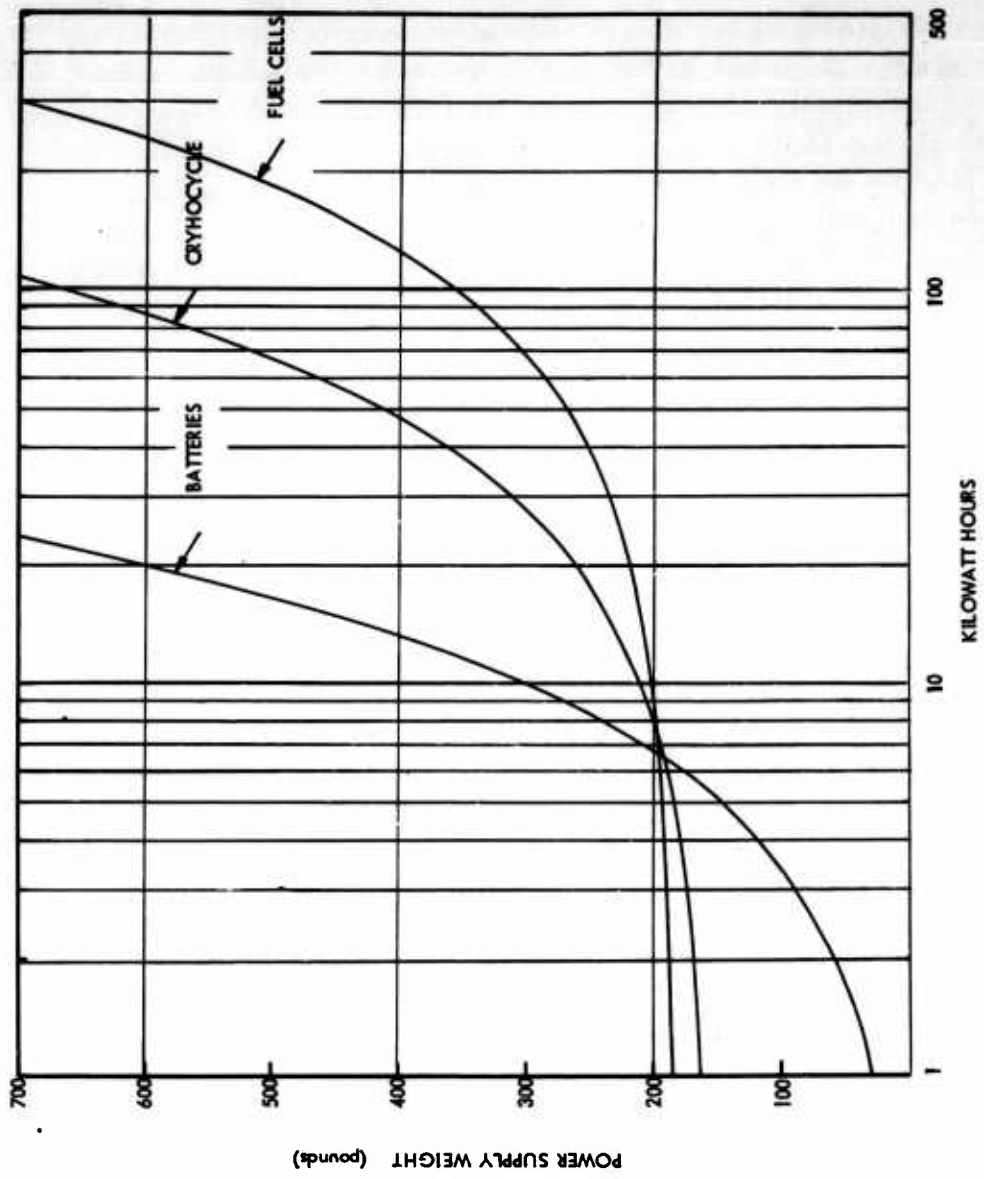

FIG. 6-23 POWER SUPPLY WEIGHT VS MISSION TIME

A zinc-silver battery is best suited for the shuttle. Although hermetically sealed nickle-cadmium and silver-cadmium cells were considered because of their long cycle life, maximum life requires that they be shallow discharged to only a fraction of their capacity and then recharged. The principal trade-off for batteries then becomes the number of watt hr/lb that can be realized. Zinc-silver batteries deliver a nominal 40-60 watt hrs/lb which is considerably greater than the other two types and thus, the most suitable. Using 44 watt hrs/lb with a 0.8 capacity loss factor, approximately 68 lb of zinc-silver cells are required for the shuttle load of 2400 watt-hrs.

6.6.2 System Description

Figure 6-24 diagrams the basic electrical power system. Two zinc-silver battery banks, each having a 1200 watt hr rating, are connected to separate 28-v dc buses. These buses are normally isolated; the utilization equipment necessary for life support and vehicle control are on one bus and mission oriented equipment on the other. Each of the subsystems, however, can be connected to either bus. In the event of a bus failure, or if power drops below a predetermined level of demand, the equipment essential to mission completion or recall can be switched to the operating bus.

Provisions are made through a bus tie, for bus interconnection under circumstances where the utilization equipment demands exceptionally heavy electrical loads.

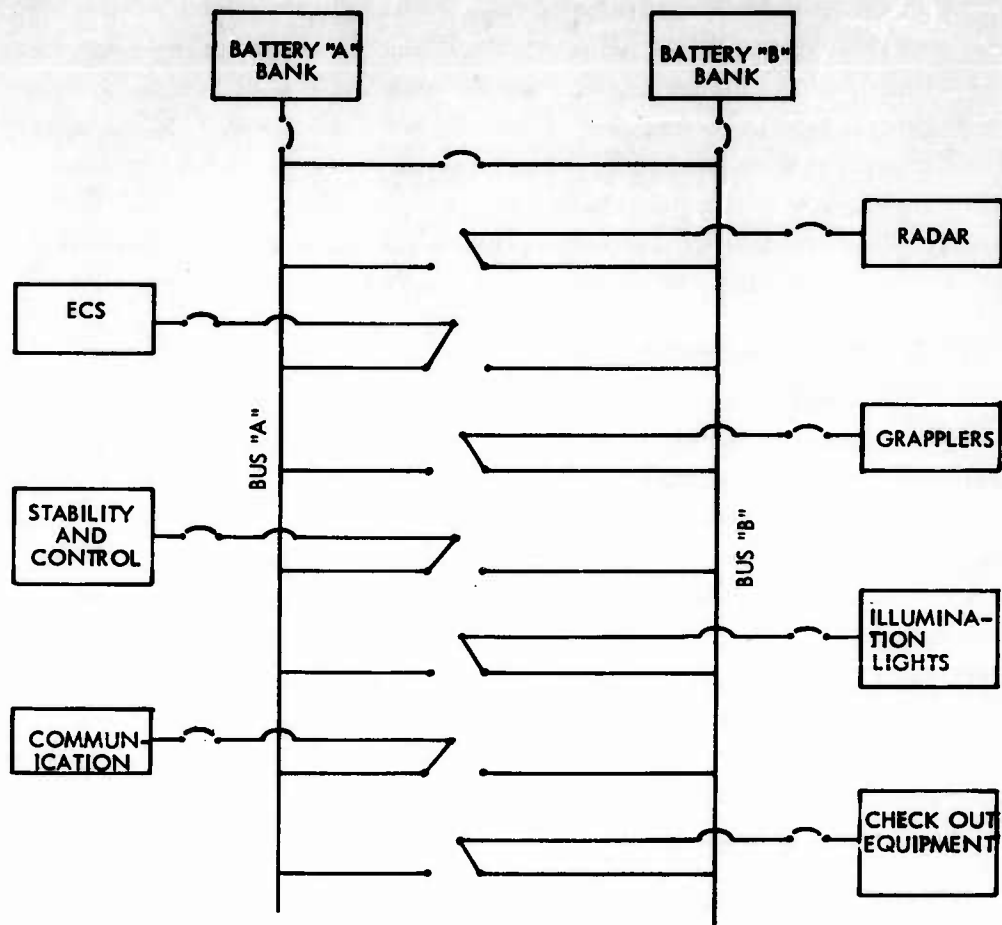

FIG. 6-24 DIAGRAM - ELECTRICAL POWER SYSTEM

6.7 COMMUNICATIONS

The basic mission requirements for a shuttle communication system are command and liaison with the primary vehicle and liaison with manned targets. The primary vehicle maintains cognizance of all shuttle operations and issues commands for mission redirection, recall, abort or other orders as the situation dictates. Pilot assistance in performing mission tasks and rendezvous maneuvers is available through liaison with the primary vehicle or manned targets. In the event of failure in the primary navigation system, the communication link provides for a back-up guidance mode using established procedures.

6.7.1 Design Considerations

The operating frequency is not considered critical in free-space conditions except from antenna design and allocation standpoint. Low frequencies are desirable to minimize masking where shuttle attitudes might shield the signal in the direction of the receiver. However, if the antenna is loaded to reduce its physical size, it becomes inefficient from a radiated power standpoint. Extra high frequencies are desirable from a weight standpoint, but efficient antennas become directional and aggravate the masking problem. From these points of view, an operating frequency in the region of 300-400 megacycles is practical. Omnidirectional coverage is achieved through a small dipole antenna, and masking is reduced by using two dipoles in parallel. Off-the-shelf hardware is available in this frequency spectrum and it is expected that most space vehicles will be equipped to communicate in this region.

The communicating distance is established as 20 mi., thus the power requirements are not a matter of concern. The modulation bandwidth for good voice reproduction using amplitude modulation is 6000 cycles. To guard against cosmic noise and external signaling interference, a margin of 20 db above noise power level is adequate to provide a completely reliable link. With these parameters assumed, the following calculations determine the essential characteristics of the communication system.

At a maximum distance of 20 Mc between the shuttle and primary vehicle with a carrier frequency of 400 Mc, the basic transmission loss (L_{bf}) for isotropic antennas in free space is:

$$L_{bf} = 37 + 20 \log_{10} (20 \text{ mi.}) + 20 \log_{10} (400 \text{ mc}) \quad (84)$$

$$L_{bf} = 115 \text{ db}$$

A receiver noise figure of 10 db for a 400 mc/s operating frequency may be expected, and with a 3000 cycle modulation frequency the noise power is:

$$P_N = F K T B = 10 \times 1.38 \times 10^{-23} \times 290 \times 6000 \quad (85)$$

$$\begin{aligned} \text{db} &= -204 + 10 + 10 \log_{10} 6000 \\ &= -126 \text{ dbm} \end{aligned}$$

where

F = receiver noise figure in watts

K = Boltzman's constant in joules/deg Kelvin

T = temperature in degrees Kelvin

B = bandwidth in cycles per second

Assuming the omnidirectional antennas on the shuttle and primary vehicle to have no power gain and a margin of 20 db provided for acceptable S/N ratio and allowance for signal interference, the transmitter power required is:

$$P_t + G_t + G_r + P_N = L_{bf} + M_i$$

$$P_t + 0 + 0 + 126 = 115 + 20 \quad (86)$$

$$P_t = 9 \text{ dbm}$$

$$= 8 \text{ milliwatts of transmitter power}$$

Assuming 1 db for transmission line loss and an additional 3 db for connecting two dipoles in parallel, the total transmitter power requirement is 20 milliwatts.

6.7.2 Component Description

From the foregoing analysis the basic characteristics of the communication system are as follows:

6.7.2.1 Operational Features

The receiver-transmitter unit operates on a single channel at a frequency of 400 Mc. A self-contained tone oscillator provides for beacon transmit. The transmitter output power is 20 mw into a 50 ohm load and the receiver has a sensitivity of .8 microvolts. The R/T unit is connected to two parallel dipoles to reduce masking effects due to vehicle orientation.

6.7.2.2 Physical and Electrical Characteristics

R/T unit dimensions	1.0 x 1.5 x 3.0 in.
Dipole antenna (2) dimensions	12 in. long
Input power	50 mw
Total System Weight	2 lb

Note: All features are estimated.

6.8 STRUCTURAL SYSTEMS

6.8.1 Introduction

The shuttle structural system is designed to provide protection from the space environment, and structural integrity for all loading conditions encountered during performance of the basic missions, i. e. capsule pressurization, and loads imposed by; booster, propulsion thrusting, docking, and the handling of various targets in orbital operations, such as in-space assembly, transfer of cargo, etc. During launching, the shuttle is housed within the launch vehicle adapter and reentry capability is not required of the shuttle, consequently, it does not experience aerodynamic loads or the extreme heat conditions of reentry.

During boost, it is proposed that the shuttle be supported in the adapter by attachment to the docking hatch, with hatch top-side, such that boost accelerations are carried as tension loads in the shuttle framework, making this a non-critical design condition. Lateral supports may be introduced at the grapppler support fittings. Mounting provisions may be made to attenuate shock and vibrations such that they will also be a non-critical factor in vehicle design. In general, the critical loading condition for the capsule structures is found to be those loads imposed by capsule pressurization.

6.8.2 Requirements

The guidelines for structural design of the vehicle are as follows:

Load Criteria

- Limit load factor (shuttle unmanned) 6.0 g
- Ultimate safety factor 1.5 g
- Pressure vessel proof factor 1.33 g
- Pressure vessel ultimate factor 2.0 g
- Ground handling limit load factor 3.0 g
- Cabin nominal working pressure 5.0 psi

Thermal Criteria

Allowable stress levels of all materials are to be compatible with the space environment, with particular emphasis being given to:

- Temperature extremes
- Insulation provisions
- Lubrication deterioration
- Meteoroid protection sufficient to give 0.999 probability of no penetration in a 5-hour exposure.

6.8.3 Structure - General

The major components of the shuttle structure are: the pressurized capsule, propellant tanks, engine supports, mechanisms and hatches.

A prime consideration in the design of the capsule is the attainment of: a pressurized cabin with good sealing characteristics, a light weight structure, adequate meteoroid protection, compatibility with easily operable hatches, and adequate window areas for good visibility.

In order to keep the use of mechanical fasteners and their potential sources of leakage to a minimum, a weldable aluminum alloy, 5456-M343 is used for all skin and stiffener elements. Spot or seam welding is used for joints wherever practical.

6.8.3.1 Basic Structure

The shuttle basic structure is composed of two main capsule sections which are mated at an interface frame. The forward capsule, as shown in Fig. 6-9, contains the work hatch and windows. The aft capsule, as shown in Fig. 6-6, serves as the primary structural base of the vehicle and houses the crew and functional subsystems.

The aft section is made up of a barrel-like segment at the rear, which fairs into double contoured side panels. These side panels are stiffened by two main frames and an interface frame, at the canopy capsule juncture.

Lateral tie members, at crew seat level, are incorporated to reduce bending loads in the main frames.

The forward section is basically semi-cylindrical in shape, providing an effective pressure vessel, and presenting no unusual structural problems.

Combining the forward and aft sections at the interface frame makes up the complete pressure carrying capsule.

6.8.3.2 Frames

The main frames in the relatively shallow double contoured transition area on the sides of the aft capsule are the most critical, since they are subject to pressurization bending loads. Using the 10 psi ultimate pressure and 7" frame spacing, the "Z" section frames, three inches deep, as shown in Fig. 6-6, give adequate margins of safety. The secondary frames in the forward and rear segments experience only small bending moments, since they are part of a nearly cylindrical pressure vessel.

6.8.3.3 Capsule Covering

The covering on both capsules is 0.020 5456-H343 aluminum alloy skin. The skin carries the 10 psi ultimate pressure in catenary action and distributes it to the frames. The hoop tension gage in the forward cylindrical section is given by:

$$t = \frac{PR}{F_{tu}} = \frac{10(40)}{20,000} = 0.020 \text{ in.} \quad (85)$$

Insulation, quarter-inch thick at 6 lb/ft³, with an 0.005 aluminum foil outer covering is bonded to all skin coverings to provide thermal stability to the capsule and the external tank modules.

6.8.4 Windows

All windows are composed of two independent panels. The inner panels are pressure carrying members and are fabricated from high strength monolithic chem-cor glass, with reinforced edges to insure adequate attachment to

the frame. An 0.06 plex 55 non-pressure carrying outer panel, with reflective coatings, provides for meteoroid and solar protection.

6.8.5 Grapplers

An important consideration is that of providing mechanisms which will operate satisfactorily when exposed for long durations to space. The grapplers are therefore coated with insulation, and a solid film lubricant is used on all bearing surfaces to minimize friction loads.

Due to the precise hovering capability of the shuttle, no severe loading conditions on the grapplers are normally anticipated during docking or grappling maneuvers. In order to provide adequate stiffness in the members, however, a design loading of 1 g is used for sizing of the grapples and support members. Designing to this load criteria permits the use of the grapples system for support of the vehicle on the ground, if desired.

6.8.6 Meteoroid Protection

Because of the small surface area, short mission times, and the protection incorporated by the structure and shelter, meteoroids present no significant hazard. It is estimated that while the shuttle is manned and performing a mission, the probability of a puncture is negligible. This is based on Whipple 1963 and 1961 data, as shown in Fig. 6-25.

6.9 WEIGHT STATEMENT

Table 6-2 presents a weight summary of a shuttle having the maximum mission capability, such as transport or maintenance. It has a ΔV capability of 2,200 ft/sec for the shuttle operating alone.

Table 6-3 presents a weight summary for a training type mission, as might be performed with a Gemini vehicle. It differs from the maximum mission in that it does not have shelter, work hatch, and grapples gear. It has a ΔV capability of 800 ft/sec to perform the training mission.

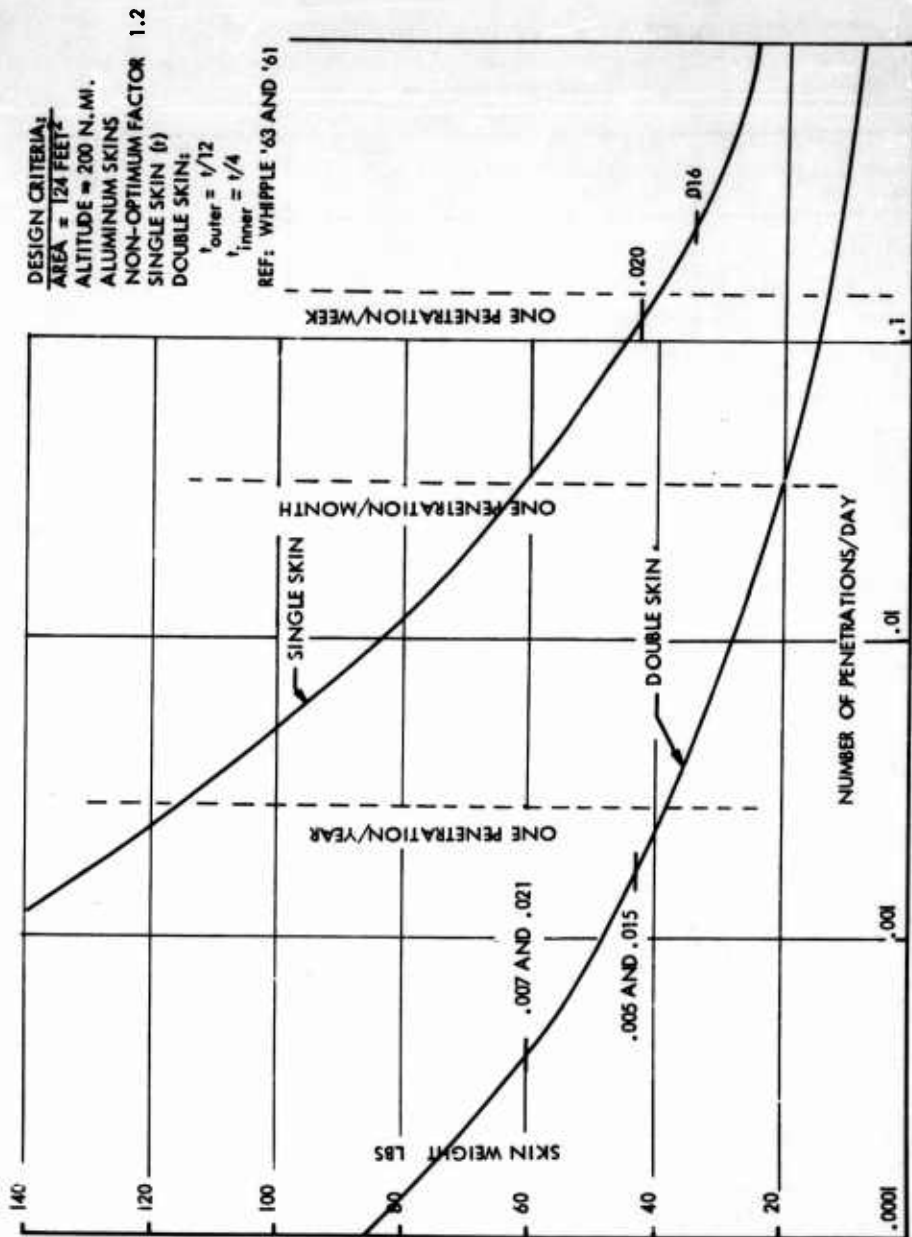

FIG. 6-25 METEOROID PROTECTION - SKIN WEIGHT VS PENETRATIONS/DAY

Table 6-2
WEIGHT STATEMENT PRELIMINARY DESIGN
Maximum Mission

	<u>Wt</u> <u>(lb)</u>	<u>Wt</u> <u>(lb)</u>
<u>STRUCTURAL</u>		238
Skin and insulation	60	
Ring and stiffeners	46	
Working hatch	45	
Docking and hatch	27	
Shelter	14	
Viewing areas	24	
Attachments and hardware	22	
<u>MECHANICAL</u>		
Main grappler	28	
Nose grappler	11	
Motors	14	
Controls and wiring	5	
<u>ENVIRONMENTAL CONTROL SYSTEM</u>		88
O ₂ system	40	
H ₂ system	6	
Crew system	18	
Liquid loop	13	
Cabin system	11	
<u>ELECTRICAL POWER SUPPLY</u>		87
Batteries	68	
Circuit breaker panel	10	
Wiring and supports	9	
<u>ATTITUDE CONTROL SYSTEM</u>		87
Thrust chambers	12	
Tankage	10	
Valves, sensors, etc.	30	
Guidance logic and controls	15	
Hardware	5	
Attitude Reference package	10	
Gyro package	5	

Table 6-2 (cont'd)

WEIGHT STATEMENT PRELIMINARY DESIGN

Maximum Mission

	<u>Wt</u> <u>(lb)</u>	<u>Wt</u> <u>(lb)</u>
<u>MAIN PROPULSION SYSTEM</u>		128
Thrust chambers	46	
Tankage	20	
Valves, sensors, etc.	53	
Hardware	9	
<u>COMMUNICATION AND NAVIGATION</u>		44
Transceiver	5	
Antenna	1	
Indicators	5	
Radar	13	
Antenna	10	
Wiring and hardware	10	
<u>MISCELLANEOUS</u>		44
Seat	4	
Fire extinguisher	10	
First aid kit	5	
Trim and displays	10	
Rations	5	
Spotlight	10	
<u>CONTINGENCY</u>		23
Dry weight		797
<u>PROPELLANT</u>		270
<u>OXYGEN, WATER AND ABSORBANTS</u>		37
<u>TOOLS, SPARES AND TEST SETS</u>		160
Gross weight (less crew)		1264

Table 6-3

WEIGHT STATEMENT PRELIMINARY DESIGN

Training Mission

	<u>Wt (lb)</u>	<u>Wt (lb)</u>
<u>STRUCTURAL</u>		166
Skin and insulation	53	
Ring and stiffeners	43	
Plexiglass	16	
Docking and hatch	27	
Shelter	0	
Viewing areas	12	
Attachments and hardware	15	
<u>MECHANICAL</u>		41
Main gears	28	
Nose gear	0	
Motors	9	
Controls and wiring	4	
<u>ENVIRONMENTAL CONTROL SYSTEM</u>		64*
O ₂ system	33	
H ₂ system	5	
Crew system	12	
Liquid loop	6	
Cabin system	8	
<u>ELECTRICAL POWER SUPPLY</u>		53
Batteries	37	
Circuit breaker panel	10	
Wiring and supports	6	
<u>ATTITUDE CONTROL SYSTEM</u>		77
Thrust chambers	12	
Tankage	10	
Valves, sensors, etc	30	
Guidance logic and controls	15	
Hardware	5	
Gyro package	5	

*The ECS system with glycol loop deleted and reduced gas and fluid requirements associated with reduced leakage rate and equipment heat load, results in lower system weight.

Table 6-3 (cont'd)

WEIGHT STATEMENT PRELIMINARY DESIGN

Training Mission

	Wt (lb)	Wt (lb)
<u>MAIN PROPULSION SYSTEM</u>		128
Thrust chambers	46	
Tankage	20	
Valves, sensors, etc.	53	
Hardware	9	
<u>COMMUNICATION AND NAVIGATION</u>		44
Transceiver	5	
Antenna	1	
Indicators	5	
Radar	13	
Antenna	10	
Wiring and hardware	10	
<u>MISCELLANEOUS</u>		19
Seat	4	
Fire extinguisher	0	
First aid kit	0	
Trim and displays	10	
Rations	0	
Spotlight	5	
<u>CONTINGENCY</u>		18
Dry weight		610
<u>PROPELLANT</u>		65
<u>OXYGEN, WATER AND ABSORBANTS</u>		25
Gross weight (less crew)		700

6.10 COCKPIT ARRANGEMENT

The cockpit arrangement as shown in Figs. 6-2 and 6-26 is designed to accommodate the man and to provide him with proper facilities to perform his tasks during all required missions. Total volume of the cabin is 95 cu. ft. Equipment volume is approximately 10 cu. ft., leaving approximately 85 cu. ft. available to the man.

6.10.1 Hatches

Crew ingress and egress to the primary is through the docking hatch which is postulated as being compatible with docking facilities in the primary.

A forward combination primary viewing window and openable working hatch is incorporated, to provide a means for the man in a pressurized space suit to conduct maintenance and repair work. The cabin, of course, is unpressurized during this operation. An extension of the suit environmental control umbilical permits suit operation from the vehicle ECS system.

6.10.2 Shelter

During a maintenance type operation, the extensible shelter as shown in Figs. 6-10 and 6-27 may be adjusted to encompass the work area to provide the man protection from meteoroids and attenuate solar rays and associated glare and high contrast light effects. The shelter is extensible through application of N₂ gas into tubular members of the shelter. The man retracts the shelter manually after completion of his task, bleeding off the gas in the shelter tubes through a valve.

6.10.3 Working Aids

During missions requiring the use of this work hatch, convenient provisions, as shown in Fig. 6-27, are incorporated for storage of check-out gear, tools, and spare part components such that extensive reaching and worker movement is kept to a minimum.

Toe restraints, the same as those used in the seating position are adjustable to give the worker good support while working. Hip restraints are also provided if needed. All tools are equipped with suitable lanyards to avoid uncontrolled movement of tools if dropped.

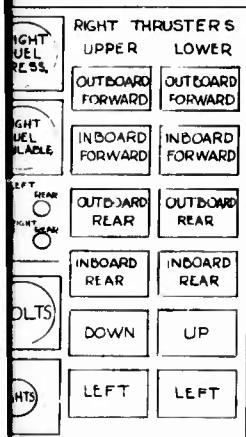

LOCAL PANEL



EL

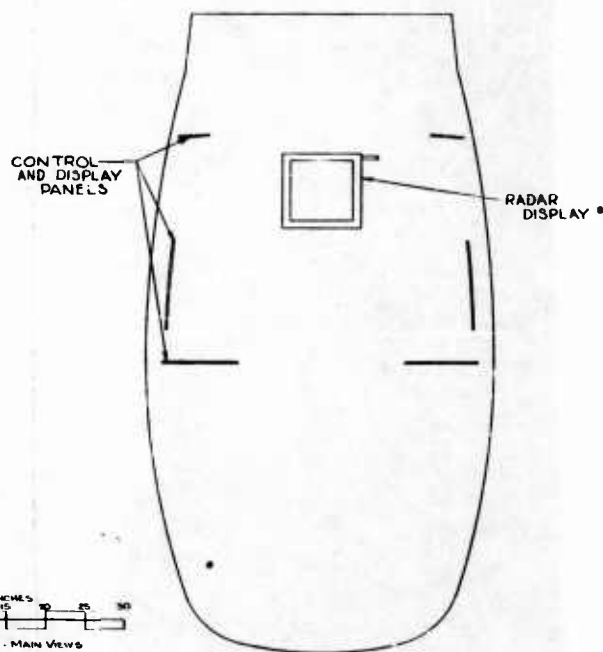
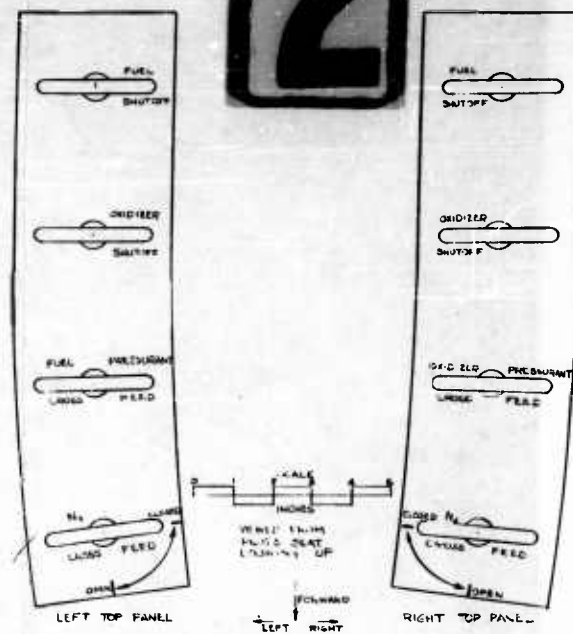
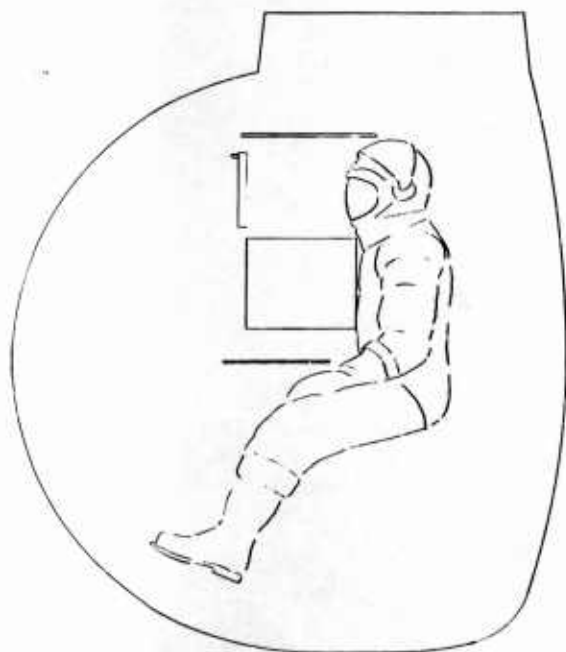
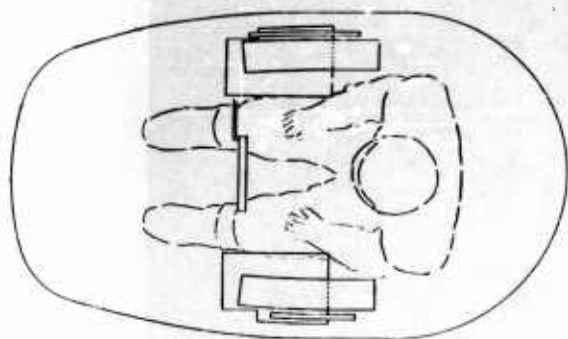
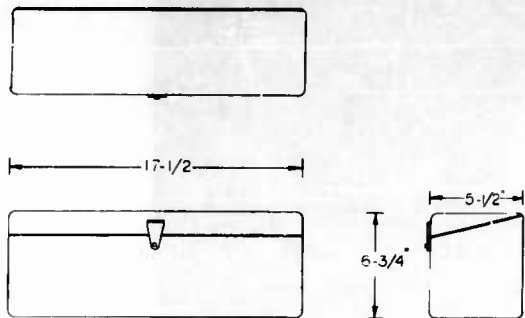
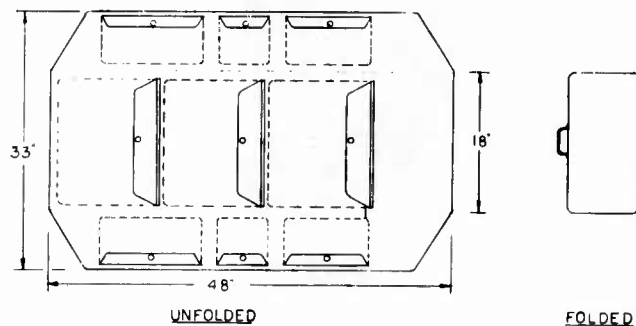

FIG. 6-26 SHUTTLE COCKPIT ARRANGEMENT



FIBERGLASS TOOL AND PART STOWAGE BOX WITH INTERIOR POCKETS

DETAIL A



UNFOLDED

FOLDED

PORTABLE CLOTH SPARE PARTS BAG

DETAIL B

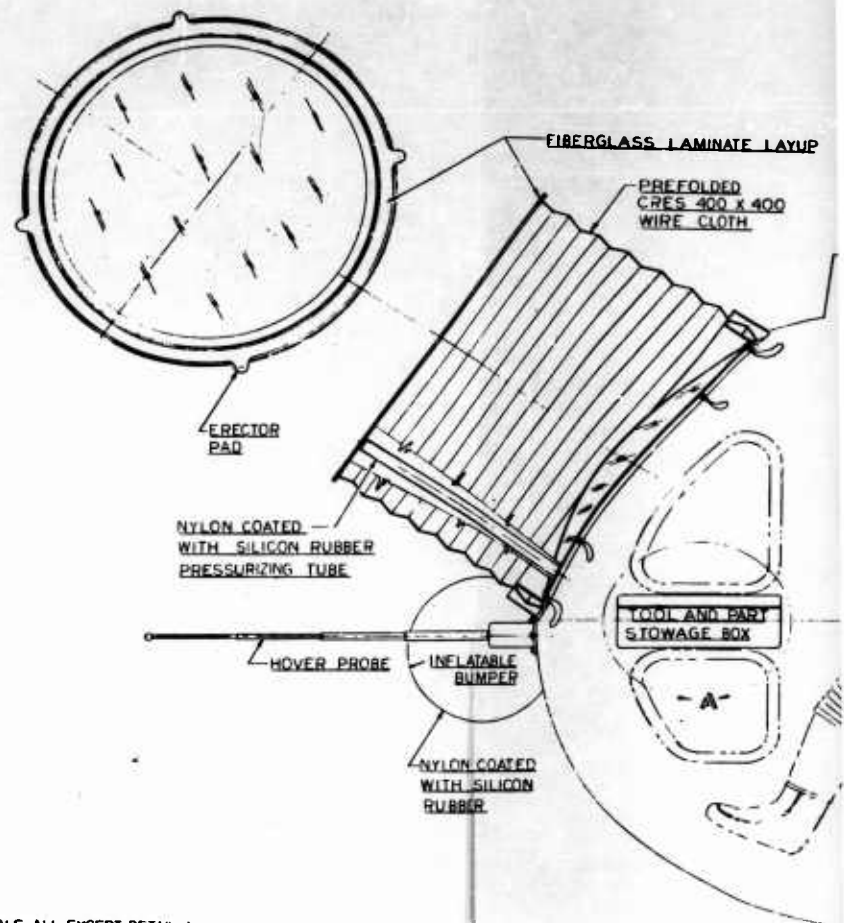

SCALE-ALL EXCEPT DETAIL A
INCHES
0 6 12 18 24
0 0.5 1.0 1.5 2.0
FEET

1

FIG. 6-27 SHU

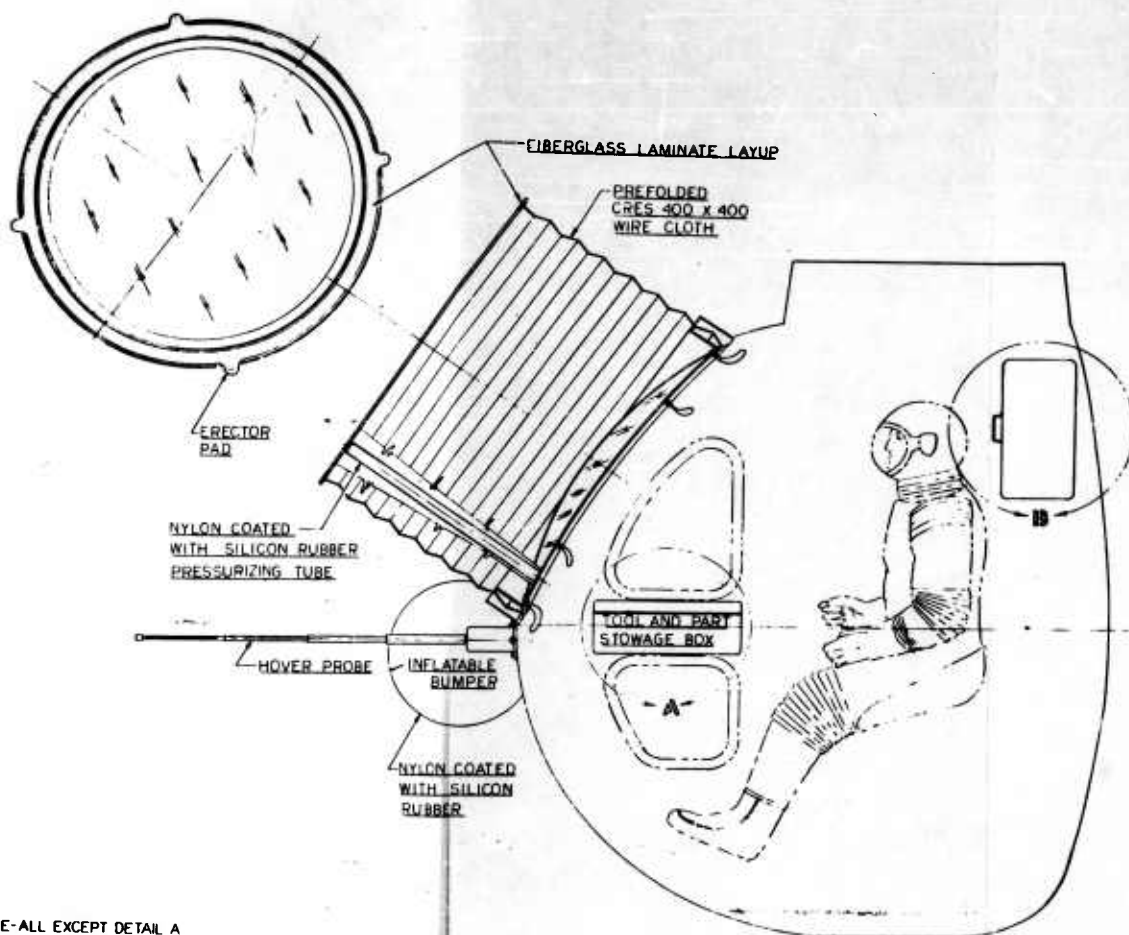

SCALE-ALL EXCEPT DETAIL A
INCHES
0 6 12 18 24
0 0.5 1.0 1.5 2.0
FEET

2

FIG. 6-27 SHUTTLE MAINTENANCE EQUIPMENT ARRANGEMENT

6.10.4 Crew Support

During all maneuvering, the crewman is positioned in a saddle type seat equipped with an adjustable hip restraint harness. The seat is adjustable fore and aft, to facilitate use of the view port in docking hatch during lock-on to the primary. The forward position of the seat is also utilized during the process of opening the forward hatch.

Toe restraints are provided with adjustment features to accommodate the preference of the crew man.

A multiple window pattern, as shown in Fig. 6-28, provides a wide range of visibility for use during the various missions. They are specifically oriented to facilitate use of grapplers and the final latch-on to the target or primary.

6.10.5 Controls and Displays

Control and display panels are conveniently located to the man during all phases of the mission as illustrated in Fig. 6-26.

The crewman need not alter his relation to the controls or displays during any required flight maneuver.

The hand controller and associated switching for attitude stabilization is located to his right, at arm-chair-rest height. Translation controller and associated switching is located similarly on the left.

Critical readouts on left and right propulsion systems are displayed on panels located on his left and right sides at a convenient viewing and operating distance. ECS controls and displays are located overhead on panels within normal reach and vision limits.

All controls and displays are kept to the sides or overhead to keep the frontal area of the cabin usable for the maintenance work mode.

6.10.6 Curtains

To avoid excessive temperature effects at windows, light weight thermal control curtains are provided at each window, arranged similarly to current transport aircraft practice. These curtains are drawn during maintenance operations if needed and during stand-by at the primary.

6.10.7 Life Support

Food and water storage provisions consist of a small fabric pouch-like container fastened within reach, on the right side below the instrument panel. Food and water is limited to 1 lb of food and 4 lb of water packaged in squeeze type containers.

6.10.8 Maintenance Equipment Arrangement

The shuttle maintenance equipment arrangement is shown in Fig. 6-27. Only the equipment necessary to service the particular satellite in question is carried by the shuttle which includes: hand tool kit, common and primary system spares, primary system test set, common system test set, and the primary system test set peculiar to the satellite to be serviced. The resulting volume is approximately 1.7 cu ft.

A breakdown of equipment and volumes based upon data defined in Section 3.1.3, follows:

Estimated Volume of Required Storage Space (cu in)

Tools and equipment carried on all missions

Hand tool kit	350
Common system spares	800
Common system test set	590
Primary system spares	<u>800</u>
	2540

Average volume of the parts test set $\frac{+ 434}{2974} = 1.7 \text{ cu. ft}$

Fig. 6-27 shows storage arrangement for above tools and spare parts.

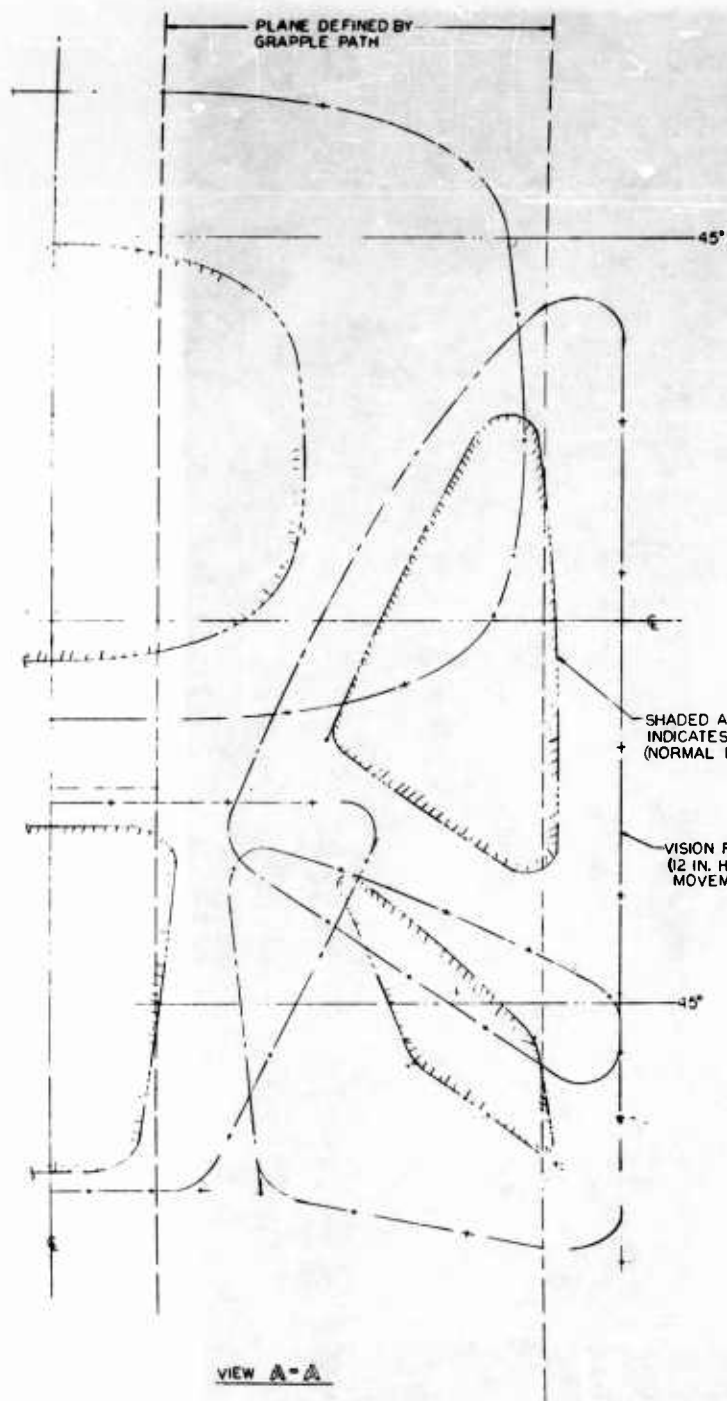

1

SHADED AREA INDICATES VISION FIELD (NORMAL POSITION)

VISION FIELD (12 IN. HEAD MOVEMENT)

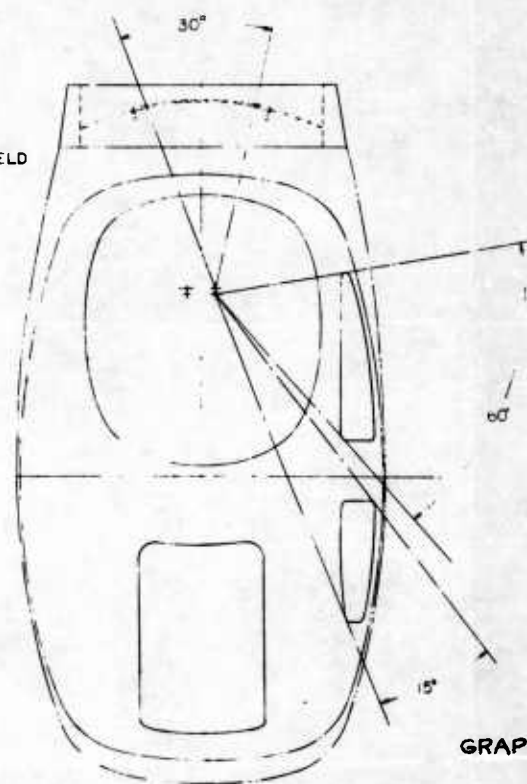

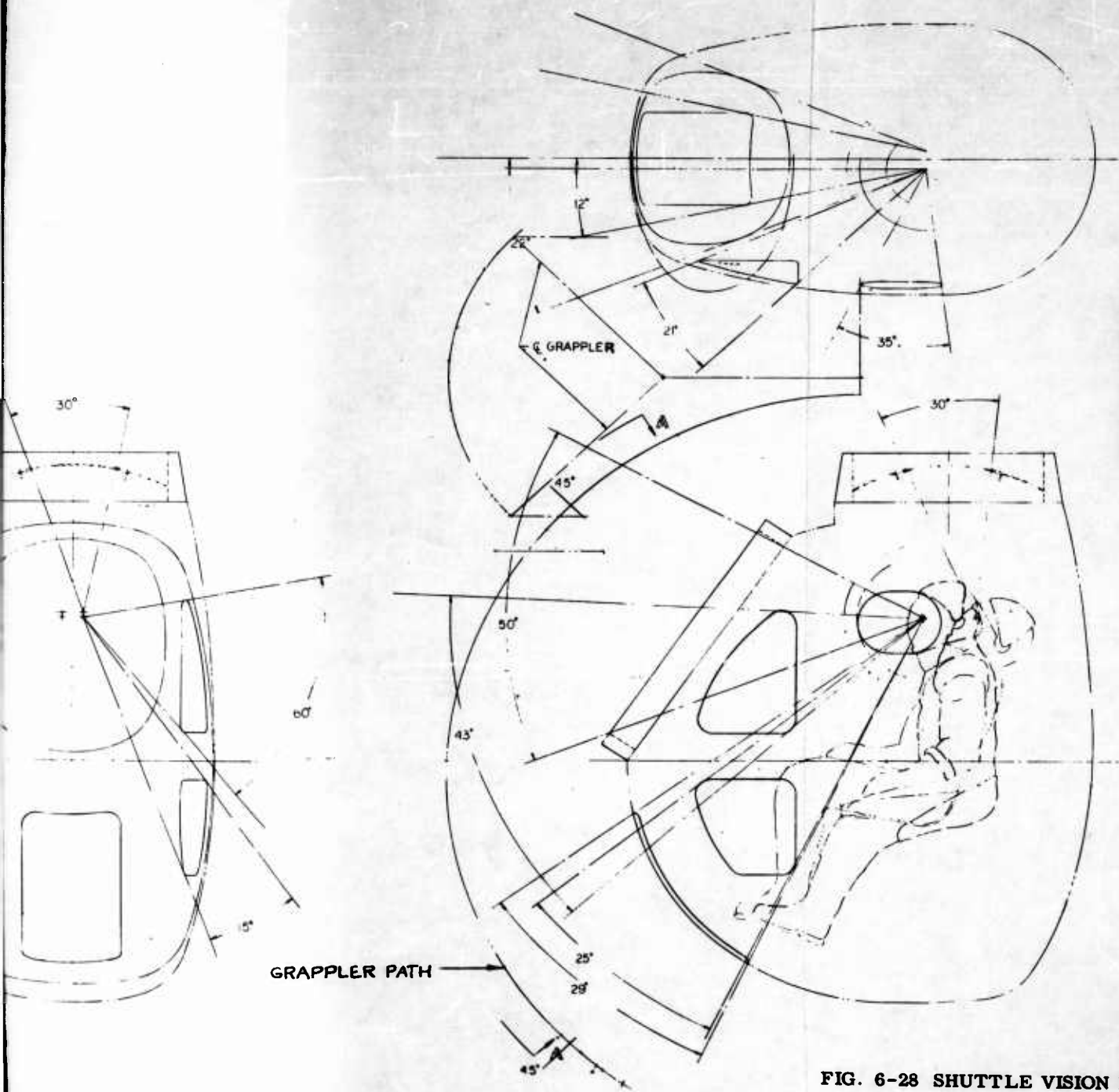

FIG. 6-28 SHUTTLE VISION ENVELOPE

6.11 GRAPPLER SYSTEM

Effective accomplishment of the shuttle missions requires the ability to adhere to and transmit translation forces to various target vehicles. The grapppler system, as shown in Fig. 6-29, gives the shuttle this capability.

6.11.1 System Description

The grapppler system is, in general, composed of three electro-mechanical arm-like grapplers, controlled by the crewman through electric circuitry linked to a master control stick located on the left hand control console in the cabin.

Two grapplers are located, one on either side of the capsule, near the centroid of the vehicle. They have two primary modes of motion. A swiveling unit at the mounting face of the cabin permits rotation of the grapppler in a vertical plane through approximately 345 deg. A secondary joint, at approximately midpoint of the arm, permits rotation of the arm extremity approximately 45 deg either side of neutral in the lateral plane. Both of these motions are accomplished through suitable linkages and electric motor driven actuators.

The outermost section of these grapplers incorporate an extensible unit which terminates in the grappling jaws.

The extensible unit is an electrically-driven, ball-bearing jack screw. A splined shaft housing is utilized in order to prevent rotation of the jaw-like unit. These jaw-like units are used to grip pre-arranged "holds" incorporated into the various cooperative satellites, deep space boosters, as well as space station and cargo modules.

A third grapppler is installed on the lower center line of the vehicle. Its members rotate in the same planes as those of the upper grapplers. However, it is limited in its angular travel in the vertical plane by the body of the shuttle to 180 deg. The general construction and operation of this grapppler is essentially the same as the upper two.

6.11.2 Grappler Control

Each motion of the grapppler is controlled through a single control stick. This stick is linked to a complex of switches which permit operation of the grapplers singly, or the upper pair in unison, by means of activating a selective series of switches. Direction is accomplished visually.

Motion of both grapppler members is controlled by displacement and direction of the control stick movement. A schematic of the circuitry is shown in Fig. 6-29 and a layout of the control console is shown in Fig. 6-26.

Once the operator has directed all three grapplers to their proper grasping holds on the target, the jaws may be tightened onto the hold provisions and the mechanism locked at any desired point, to permit the worker to conduct maintenance and repair operations with the shuttle held rigidly in relationship to the target. However, the operator may unlock the system, freely move the shuttle to a more advantageous position, and then re-lock it.

6.11.3 Structure

The grapppler members in general are fabricated from aluminum alloy. Hard anodizing is utilized for race ways of the ball bearing jack screws.

In order to protect vital parts from thermal extremes, polyurethane foam, approximately 1/4 in. thick, is sprayed onto all parts, except in areas where sliding or rotation takes place.

6.11.4 Adhesive Pads

A set of special pads equipped with adhesive surfaces are provided to enable the shuttle to adhere to uncooperative targets. These pads are attached to the outer members of each grapppler arm at a point where, by proper manipulation of the members, each grapppler can acquire an adhesive pad. See Fig. 6-22 The pad is coated with an adhesive, as described in section 3.2.4, and incorporates a pliable membrane at the contact surface. The pad is constructed so that the membrane is capable of imposing a relatively low but uniform pressure on the target at time of desired adherence.

At time of departure a pressurant from a nitrogen capsule stored in the pad, may be activated to enter channels in the pad which feed voids pre-arranged at a number of points between the membrane and the target surface. The gas pressure causes a peeling action which releases the pad from the target.

6.11.5 Lubrication

Solid film lubrication, such as molybdenum disulfide, is used throughout on all surfaces having relative motion.

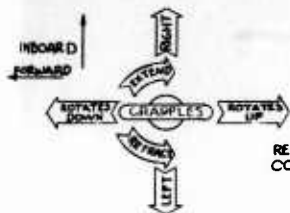

RELATIVE MOTIONS OF CONTROL & GRAPPLERS

CONTROL STICK MOVEMENT:-
FORE & AFT:- GEAR ROTATES ABOUT HORIZONTAL AXIS Y

SIDE TO SIDE:- GEAR MOVES SIDE TO SIDE (S/S)

ROTATION:- GEAR EXTENDS OR RETRACTS (E/R)

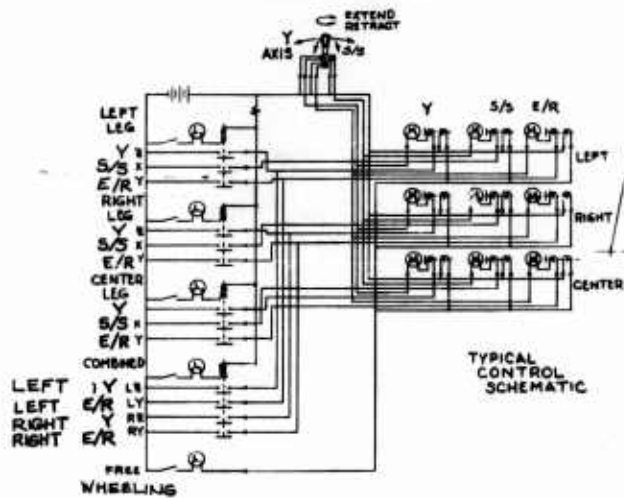

TYPICAL CONTROL SCHEMATIC

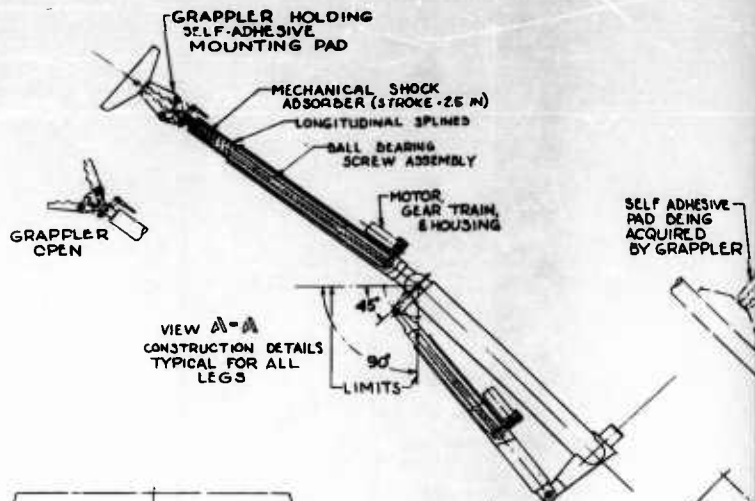

SELF ADHESIVE PAD BEING ACQUIRED BY GRAPPLER

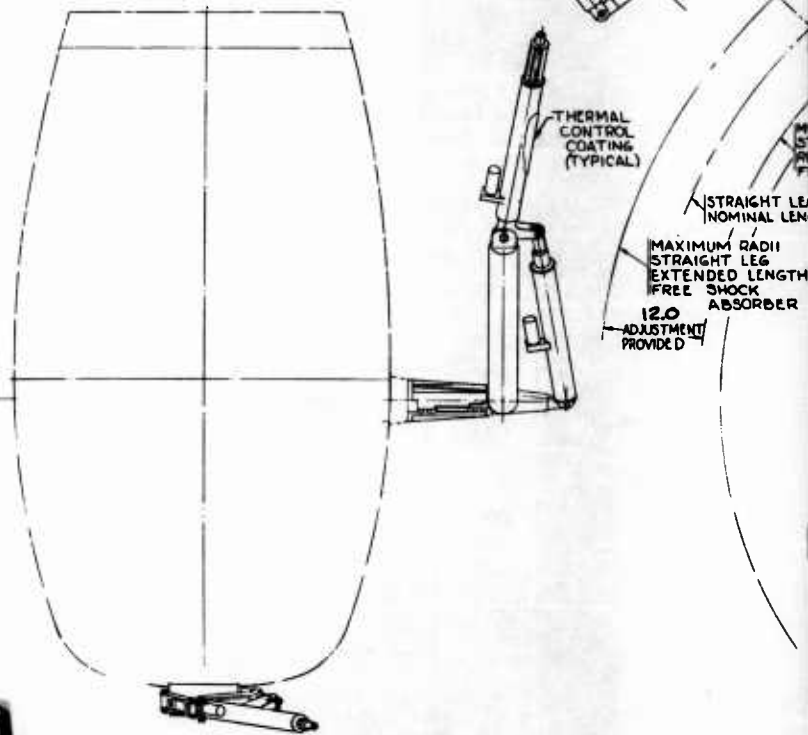

1

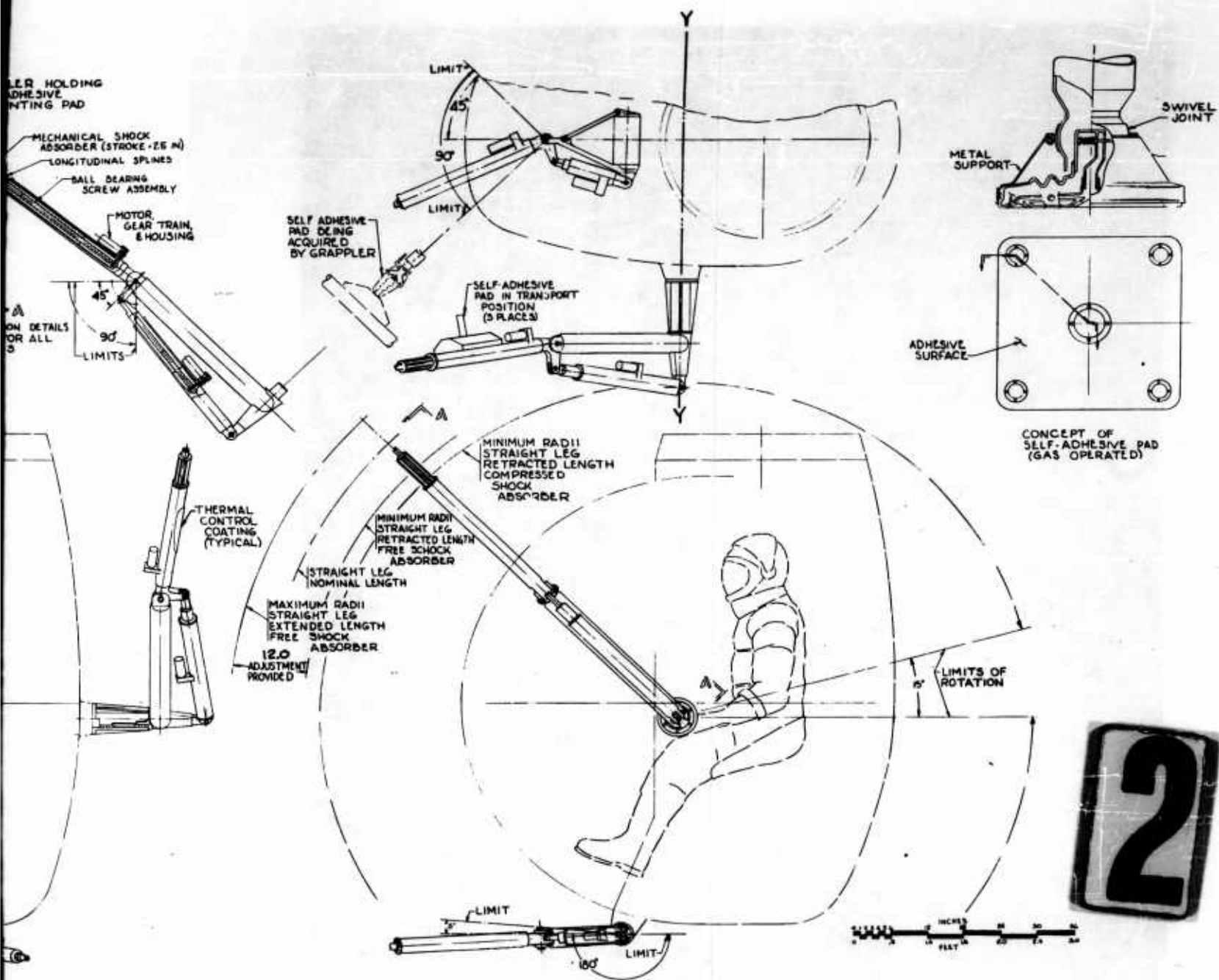

FIG. 6-29 SHUTTLE REMOTE GRAPPLER SYSTEM

6.12 RELIABILITY

The emergency situations that might be encountered by the shuttle and the operational procedures employed to neutralize them are discussed in para 3.2.2. The problem of equipment failure and its implications for the detail design of the shuttle are discussed in this section.

6.12.1 Mission Implications on Reliability

The reliability analysis of space systems emphasizes random failures and seeks to predict the frequency with which they occur. Design features to reduce this frequency to an acceptable level and to minimize the consequences of component failure are then identified and incorporated. The reusability of the shuttle vehicle, in addition, justifies considerable effort in the prevention of wearout failures. The operational success of the shuttle requires that each vehicle execute as many sorties as possible.

The basic reliability philosophy in design is to provide for (1) the greatest simplicity in hardware and operation, (2) the integration of man and machine to achieve system success under the restraint of current-technology equipment and (3) very high maintainability.

6.12.2 Critical Systems and Operations

The shuttle subsystems that are critical for crew survival are identified by reference to Table 3-5 (paragraph 3.2.2). These are the subsystems whose failure constitutes a catastrophic hazard. Fires, explosions, and loss of oxygen are considered catastrophic, and the subsystems that might be involved are the electrical, propulsion, structure and life support. The success of the mission is jeopardized by a failure in any of the vehicle subsystem or the equipment (eg, tools, electronic checkout gear) provided to perform the assigned task. As discussed in paragraph 3.2.2, the presence of a maneuverable, well equipped primary station reduces most malfunctions from a survival problem to a mission success problem.

The presence of the pilot is expected to contribute a great deal to the over-all reliability of the shuttle system, but he is also subject to failure. The

most likely, as well as most serious, human failure is expected to be mismanagement of the environmental control system, the propulsion system, and the guidance system. The first, resulting in oxygen depletion, is critical. The second, propellant depletion, requires rescue before the oxygen is also gone. The third is usually corrected by the primary which normally monitors the shuttle operation, but if coupled with a communication failure may lead to both oxygen and propellant shortage. The design solution to this problem is the provision of adequate reserves-100% life support, propellant for return from maximum range, 100% electrical power, 100% cooling water.

The prevention of damage from shock and collision during docking is considered especially critical to reliability and the design has incorporated features for minimizing this effect. The complete loss of the shuttle vehicle in the vast reaches of space is also considered a critical possibility and the current design has been carefully chosen to prevent this.

6.12.3 Shuttle System Design for Reliability

The system design for reliability in the presence of unforeseen events, off-design operation, and incomplete knowledge of the environment depends heavily on the presence of a skillful, knowledgeable, motivated crewman. The human ability to appraise a strange situation, relate the new data to the alternatives at his disposal, decide on, and take appropriate action is unique: there is no "black box" of like capability. These abilities cannot be exploited, however, unless the crew can obtain the necessary data, has alternate modes of operation available, and has access to components requiring attention. The shuttle design therefore incorporates large windows to give the crew maximum information on events near his vehicle, a radar to supplement his visual data, adequate instrumentation to monitor subsystem performance, and as much access as possible to equipment by locating it inside the cockpit.

While the human is remarkable in his ability to cope with difficult situations, proper solution of human factors problems discussed in Section 5 prevents many of these situations from arising. Providing good handling qualities, adequate acceleration for braking as well as take-off, control in all

degrees of freedom, and controls that are conveniently located and whose movement is naturally related to the vehicle action desired, all contribute to reliable system operation in trying situations.

Minimizing the effect of random failures on the shuttle system is accomplished by supplying redundant units and modes of operation for critical systems. Specific items are:

Environmental Control System

Dual oxygen bottles

Suit and cabin systems may be operated independently as alternate modes

Dual mechanical components

Propulsion and Attitude Control

Engine arrangement provides three modes of translation, three of pitch and yaw, two for roll, and engine out capability in side and vertical translation

Direct control of thrusters provided as alternate mode

Dual propulsion systems, tank, valves, pressurants are provided

Guidance Techniques - Alternate Technique

Modified visual homing plus radar

Visual homing

Communication with primary

Electrical Power

Emergency system independent of normal system

Other features of the shuttle system design aimed at preventing catastrophic failures are:

Propellants, being toxic, are routed entirely outside of the cabin

Fuel and oxidizer, being hypergolic, are isolated from each other

Separate pressurant tanks are used for fuel and oxidizer

Electrical harnesses are completely protected

It is expected that the useful life of a shuttle vehicle will greatly exceed the useful lives of thrust chamber, nozzles, propellant expulsion bladders, and batteries. Mechanical components that are exposed to vacuum are also expected to wear more rapidly than comparable parts in air. Wear-out failures are expected and design provides for easy replacement throughout the system. Critical items, such as thruster clusters and propellant tanks, are installed with a minimum of fittings and with good access.

6.12.4 Component Reliability

The subsystems chosen for the shuttle are all types that are either in use or being developed for other programs. Many components are virtually off-the-shelf. Adequate reliability of components is therefore expected to be attainable without resorting to extraordinary test and development programs.

SECTION 7

PROBLEM AREAS

7.1 REPAIR AND MAINTENANCE TECHNIQUES

The only major problem encountered in the shuttle study concerns the techniques to be used for repair and maintenance of conventional satellites. Conventional design entails use of many small parts, congested packages, welded assemblies, and special tool requirements. These practices are necessary to meet the weight and performance requirements with the current state-of-the-art and are justified when all repair is to be done in well equipped ground shops.

The experiments conducted in the program indicate that extensive repair operations in space require such design features as:

- Quick opening fasteners
- Retention of all parts, e.g., covers, screws
- Replaceable modules
- Access for gloved hands or manipulators to critical points
- Compatibility with remotely operated tools
- Use of standardized tools, latches, fittings specifically designed for space operations.

7.2 SHUTTLE VEHICLE DESIGN

No critical problems are found in the shuttle vehicle design. The critical subsystems of propulsion, environmental control, and electrical power are similar to systems being developed for other programs. Normal engineering procedures are expected to solve the shuttle design problems. Some details that require particular attention are:

- Window design
- Hatch seals
- Propellant resupply equipment
- Adhesive pads for alighting on unprepared surfaces
- Space environment effects, especially vacuum and radiation effects on bearings, lubricants and seals.

REFERENCES

- 1-1 Feasibility of a Self-Maneuvering Unit for Maintenance Workers (SMU), Astronautics Division, Chance Vought Corporation, ASD-TDR-62-278, AF 33(616)-8197, August 1962.
- 2-1 Operational Feasibility of a Conceptual Large Space Station, Spacecraft Organization, Lockheed-California Company LR 16527, NAS 1-2207, 24 January 1963.
- 3-1 Space Logistics Maintenance Rescue (SLOMAR), Vols. I and II, Spacecraft Engineering, Lockheed-California Company LR 15282, AF 33(600)-42018, August 1961, Secret.
- 3-2 Space Maintenance and Resupply Techniques (SMART), Final Report, Phase I, Spacecraft Engineering, Lockheed-California Company LR 15101, AF 04(647)-594, April 1961, Secret.
- 3-3 Study of Space Maintenance Techniques (SMT), Bell Aerosystems Company, Aerospace/Rockets Division, ASD-TDR-62-931, AF 33(657)-7838, December 1962.
- 3-4 Orbital Attachment and Docking Validation Parameters, First Quarterly Progress Report, Spacecraft Organization, Lockheed-California Company LR 16931, AF 33(657)-10466, 1 June 1963.
- 3-5 Survey of Remote Handling in Space, Aerospace Medical Division, Air Force Systems Command, Wright-Patterson AFB, AMRL-TDR-62-100, September 1962.
- 3-6 A Modular Concept for a Multi-Manned Space Station, S. B. Kramer and R. A. Byers, Manned Space Station Symposium, IAS, 1960.
- 5-1 Man's Capability in Extra Vehicular Space Maintenance, Spacecraft Engineering, Lockheed-California Company LR 16530, June 1963.
- 5-2 Remote Handling Technology and Equipment Investigation, General Mills, AFSWC-TDR-62-117, November 1962.

UNCLASSIFIED

UNCLASSIFIED