

UNCLASSIFIED

AD NUMBER

AD447862

LIMITATION CHANGES

TO:

Approved for public release; distribution is unlimited.

FROM:

Distribution authorized to U.S. Gov't. agencies and their contractors; Specific Authority; SEP 1964. Other requests shall be referred to Air Force Arnold Engineering Development Center, Arnold AFB, TN.

AUTHORITY

jul 1975 per document marking

THIS PAGE IS UNCLASSIFIED

AEDC-TDR-64-181

copy 23 1979

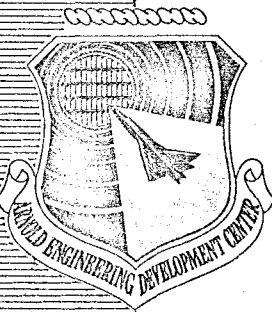

INJECTION OF PARTICLES THROUGH A JET NOZZLE LATERALLY INTO A SUPERSONIC AIRSTREAM

This document has been approved for public release
and its distribution is unlimited.

Per DDC TR-75/5
AD A011700
2+d July 1975

By

E. E. Hilliard
von Kármán Gas Dynamics Facility
ARO, Inc.

TECHNICAL DOCUMENTARY REPORT NO. AEDC-TDR-64-181

September 1964

Program Element 63406184/655A

(Prepared under Contract No. AF 40(600)-1000 by ARO, Inc.,
contract operator of AEDC, Arnold Air Force Station, Tenn.)

ARNOLD ENGINEERING DEVELOPMENT CENTER
AIR FORCE SYSTEMS COMMAND
UNITED STATES AIR FORCE

Property of U. S. Air Force
AEDC LIBRARY
F40600-77-C-0003

NOTICES

Qualified requesters may obtain copies of this report from DDC, Cameron Station, Alexandria, Va. Orders will be expedited if placed through the librarian or other staff member designated to request and receive documents from DDC.

When Government drawings, specifications or other data are used for any purpose other than in connection with a definitely related Government procurement operation, the United States Government thereby incurs no responsibility nor any obligation whatsoever; and the fact that the Government may have formulated, furnished, or in any way supplied the said drawings, specifications, or other data, is not to be regarded by implication or otherwise as in any manner licensing the holder or any other person or corporation, or conveying any rights or permission to manufacture, use, or sell any patented invention that may in any way be related thereto.

INJECTION OF PARTICLES THROUGH A
JET NOZZLE Laterally INTO A
SUPERSONIC AIRSTREAM

This document has been approved for public release
its distribution is unlimited.

*Per DDC/TR-15/5
AD A011 700
D+2 July 1975*

By

E. E. Hilliard

von Kármán Gas Dynamics Facility

ARO, Inc.

a subsidiary of Sverdrup and Parcel, Inc.

September 1964

ARO Project No. VD0459

ABSTRACT

Tests were conducted in the 12-in. supersonic tunnel of the von Kármán Gas Dynamics Facility to determine the particle distributions downstream of a nozzle exhausting particle-laden flow laterally into the airstream from the tunnel floor.

Data were obtained at Mach 3 for a range of jet pressure ratios and nozzle sizes with the nozzles located at several positions upstream of the sampling rake. Reynolds number ranged from 0.15 to 0.62×10^6 per inch. Selected results are presented.

PUBLICATION REVIEW

This report has been reviewed and publication is approved.

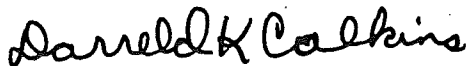

Darreld K. Calkins
Major, USAF
AF Representative, VKF
DCS/Test



Jean A. Jack
Colonel, USAF
DCS/Test

CONTENTS

	<u>Page</u>
ABSTRACT.	iii
NOMENCLATURE.	vi
1.0 INTRODUCTION	1
2.0 APPARATUS	
2.1 Wind Tunnel	1
2.2 Test Equipment.	1
2.3 Instrumentation.	2
3.0 PROCEDURE.	2
4.0 RESULTS AND DISCUSSION	3

ILLUSTRATIONS

Figure

1.	Tunnel D.	5
2.	Nozzle and Sampling Rake	6
3.	Test Equipment	
	a. Sampling Rake Details	7
	b. Nozzle and Sampling Rake Locations	8
	c. Particle Injection System.	9
	d. Filter System	10
4.	Particle Distribution on Tunnel Centerline at $M_\infty = 3$	
	a. Variation of Nozzle Position; $d_j = 0.15$ in., $p_{0j}/p_\infty = 60$	11
	b. Variation of Jet Pressure Ratio; $d_j = 0.15$ in., $x_p = 24.75$ in.	12
	c. Variation of Nozzle Diameter; $p_{0j}/p_\infty = 120$, $x_p = 24.75$ in.	12

NOMENCLATURE

d_j	Nozzle diameter, in.
M_∞	Free-stream Mach number
m	Weight of particle sample, mg
m_{\max}	Maximum particle sample weight, mg
P_0	Tunnel stagnation pressure, psia
P_{0j}	Jet chamber pressure, psia
P_∞	Free-stream static pressure, psia
Re	Reynolds number
x_p	Distance from probe leading edge to nozzle centerline, in.
y	Vertical coordinate, in.

1.0 INTRODUCTION

At the request of the Aeronautical Systems Division (ASD), Air Force Systems Command (AFSC), particle injection tests were conducted in the Gas Dynamic Wind Tunnel, Supersonic (D), of the von Kármán Gas Dynamics Facility (VKF), Arnold Engineering Development Center (AEDC), AFSC, for the Vought Aeronautics Division of Ling-Temco-Vought, Inc. (LTV). The objective of the tests was to determine the distribution at several downstream locations of particles injected laterally into a supersonic airstream. The tests were made at Mach number 3 over a range of jet pressure ratios, p_{0j}/p_{∞} , from 60 to 245 at nozzle positions from 2.80 to 24.75 in. upstream of the sampling rake. Nozzle sizes were varied from 0.0995 to 0.221 in. diameter. Tunnel Reynolds number ranged from 0.15 to 0.62×10^6 per inch.

The tests were conducted during the period from May 25 to June 10, 1964.

2.0 APPARATUS

2.1 WIND TUNNEL

Tunnel D (Fig. 1) is an intermittent, variable-density wind tunnel with a manually adjusted, flexible plate-type nozzle and a 12- by 12-in. test section. The tunnel operates at Mach numbers from 1.5 to 5 at stagnation pressures from about 5 to 60 psia and at stagnation temperatures up to about 80°F. A description of the tunnel and airflow calibration information may be found in the Test Facilities Handbook.*

2.2 TEST EQUIPMENT

The test equipment (Figs. 2 and 3) was furnished by LTV and consisted of a sonic jet nozzle mounted flush with the tunnel floor with a thirteen-probe sampling rake located downstream of the nozzle. An additional probe, designated as the "control probe", was mounted in the tunnel roof to provide data on background contamination in the tunnel air supply (see Fig. 2). Three different nozzle sizes, 0.0995-, 0.15-, and 0.221-in. diameters, were tested at four different positions

*Test Facilities Handbook (5th Edition). "von Kármán Gas Dynamics Facility, Vol. 4." Arnold Engineering Development Center, July 1963.

Manuscript received August 1964.

upstream of the rake (see Fig. 3b). The nozzle and rake were positioned on the tunnel centerline, with the rake also being positioned 1.10 and 1.72 in. off-center.

A particle injection system (Fig. 3c), consisting of a high pressure nitrogen gas supply and a disseminator, was connected to the nozzle. The disseminator was a hollow cylinder with two diametrically opposed nitrogen inlets tangent to the cylinder walls. In the operation of the disseminator, the arrangement of the inlets caused a vortex to be created by the nitrogen flow, which disrupted a column of uncompact magnesium silicate (talc) which has a particle size of 1 to 5 micron diameter. The gas entrained the particles, and the particle-gas mixture was injected into the tunnel through the nozzle.

The sampling rake was connected to a filter system (Fig. 3d) and a vacuum source outside of the tunnel. The probes of the rake were, in effect, small normal shock inlets, and these were calibrated to ensure that their flow rates were approximately the same when the vacuum system was on. The filter system included a filter for each probe and a valve assembly, containing a valve for each probe, which automatically switched the flow to or from the filters and allowed an accurately timed sample to be taken. The filters were of a "Fiberglas" material and were designed to trap particles of less than one micron diameter.

2.3 INSTRUMENTATION

Pitot pressures were measured with the Tunnel D standard pressure-scanning system using 15-psid transducers referenced to a near vacuum. The 15-psid transducers were calibrated for ranges of 15, 7.5, and 3 psia. The precision of the system is estimated to be within one percent of the ranges being used. The particle samples were weighed with a digital balance with a sensitivity of 0.1 mg. This balance was estimated to be accurate within ± 0.05 mg.

3.0 PROCEDURE

Each combination of nozzle size, nozzle position, and rake position was run at the test conditions shown on the following page.

p_{0j}/p_{∞}	p_0 , psia	$Re/in.$ x 10^{-6}
245	11.0	0.15
120	22.5	0.31
60	45.5	0.62

Before the sampling tests, the rake was connected to the tunnel pressure-scanning system to obtain pitot pressure profiles at each downstream location with nitrogen flow only from the nozzle at the various jet pressure ratios. A typical sampling run consisted of the following:

1. After tunnel flow was established, injection of nitrogen-gas-talc mixture was stabilized at the appropriate jet pressure ratio.
2. Flow was passed through filters for a timed sample.
3. Dissemination of particles-gas mixture was stopped.
4. Filters were removed for gravimetric analysis.

4.0 RESULTS AND DISCUSSION

Particle distributions on the tunnel centerline at $M_{\infty} = 3$ for selected values of jet pressure ratio, nozzle size, and nozzle position are given in Fig. 4, and these are representative of the results from all other conditions. These distributions are presented as the ratio of particle weight from each probe to the maximum particle weight obtained from any probe for a particular sampling run. The results shown indicate that the greatest concentration of particles occurred outside the tunnel boundary layer. Figure 4a, which presents distributions obtained at various locations, shows that the particle concentration moves closer to the wall as the distance from the nozzle increases. This trend can also be seen from the accompanying shadowgraph. Increasing the jet momentum by increasing the pressure ratio (Fig. 4b) or the nozzle diameter (Fig. 4c) increased the depth of particle penetration into the free stream.

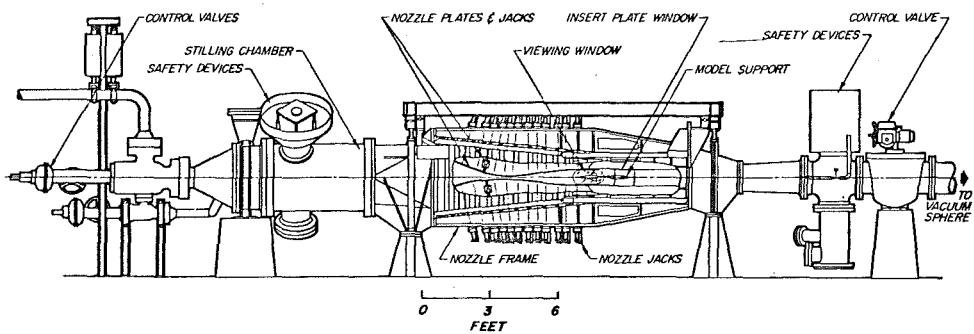

Assembly

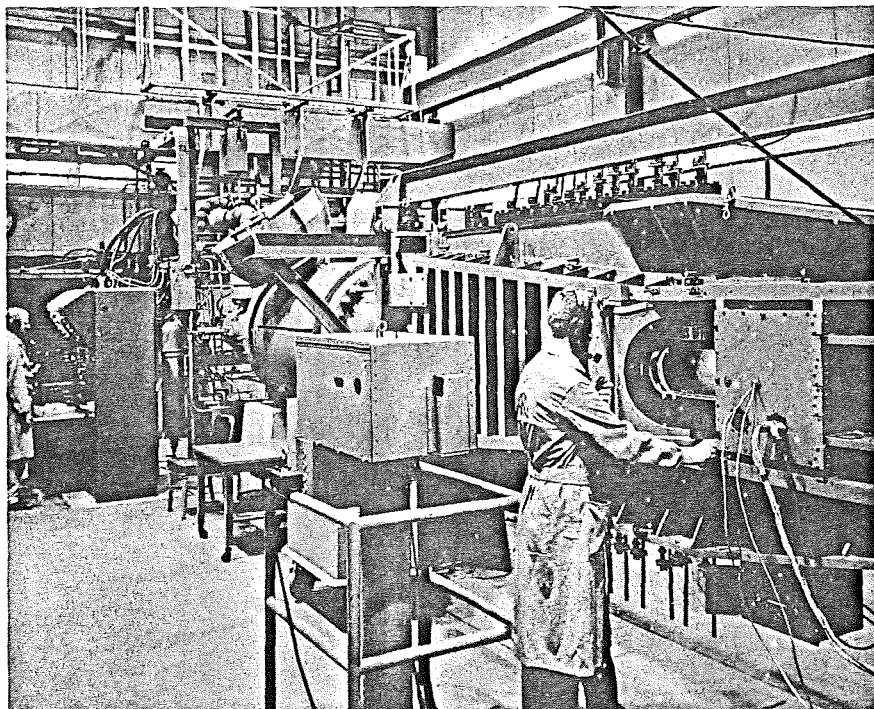

Fig. 1 Tunnel D

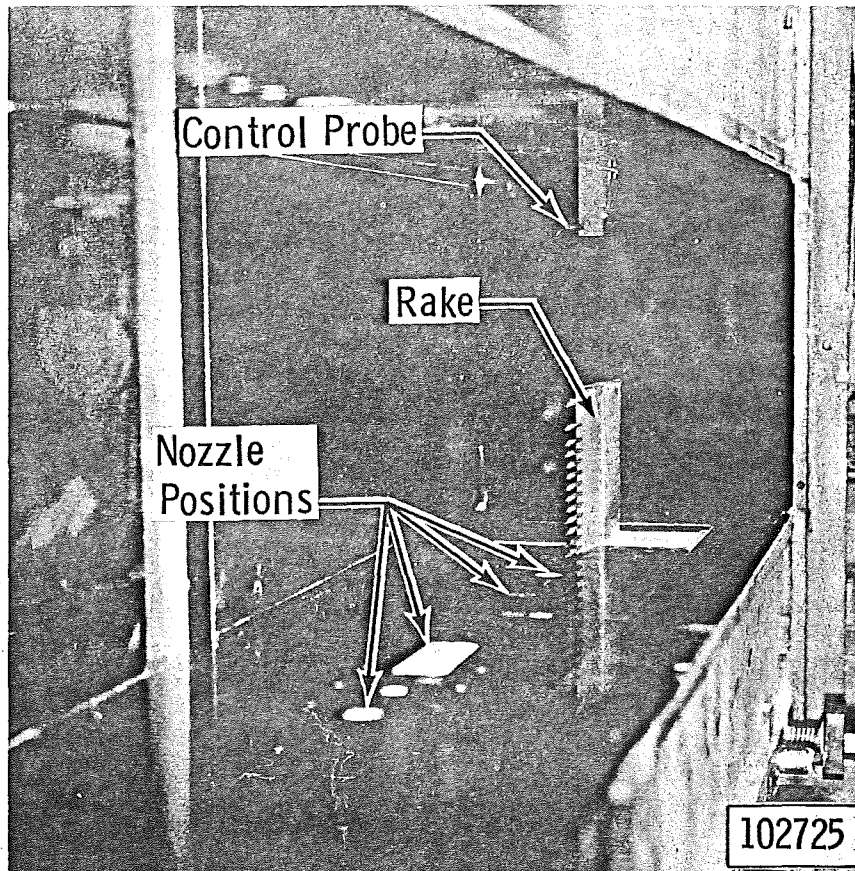
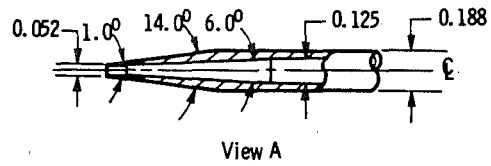
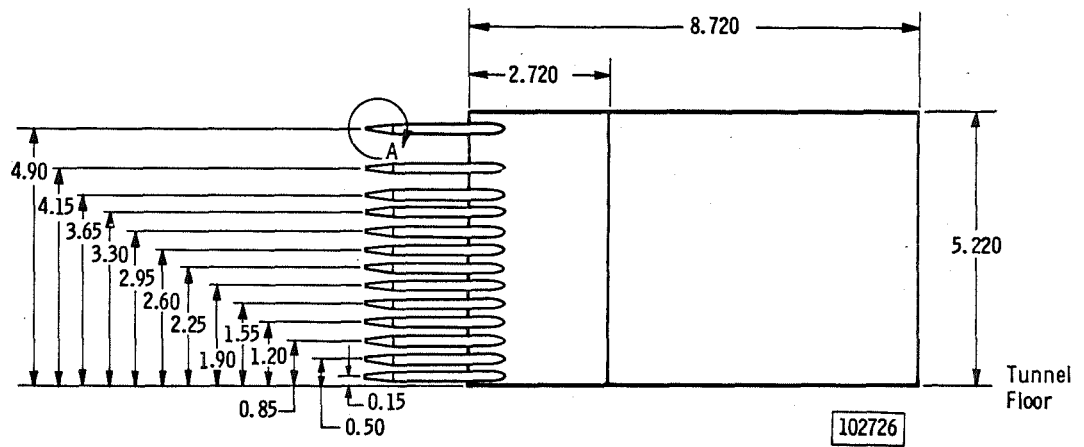
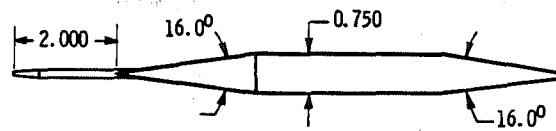

Fig. 2 Nozzle and Sampling Rake



All dimensions are in inches.



a. Sampling Rake Details

Fig. 3 Test Equipment

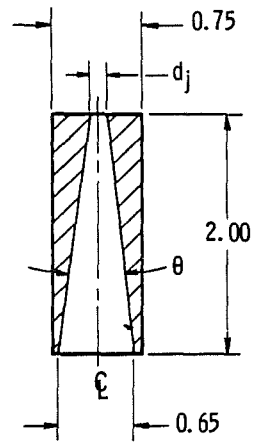

d_j , in.	θ , deg
0.2210	12.0
0.1500	14.0
0.0995	16.0

Nozzle Details

Tunnel Wall

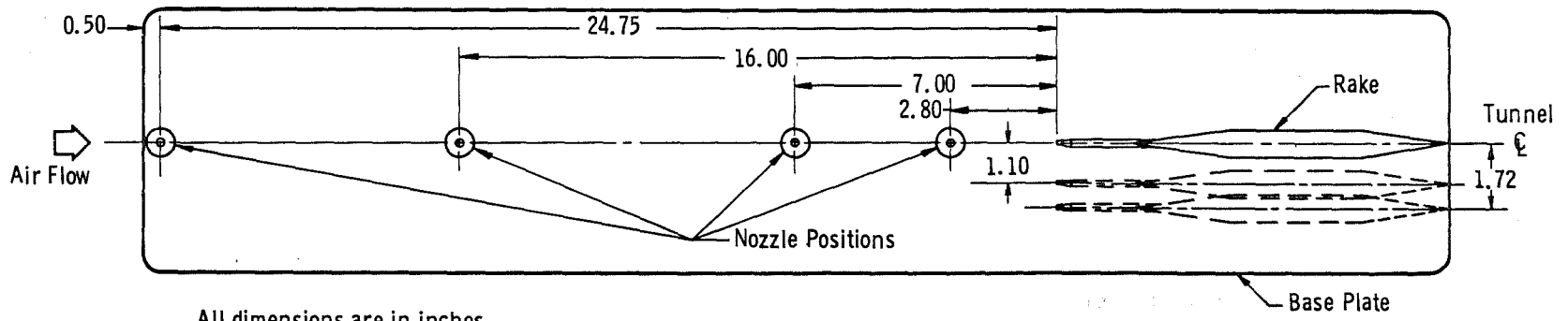

All dimensions are in inches.

Tunnel Wall

102727

b. Nozzle and Sampling Rake Locations
Fig. 3 Continued

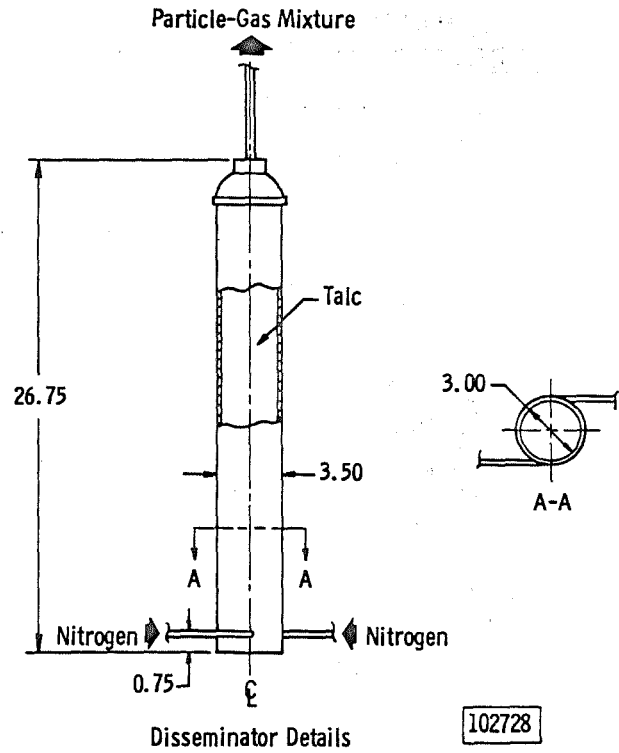
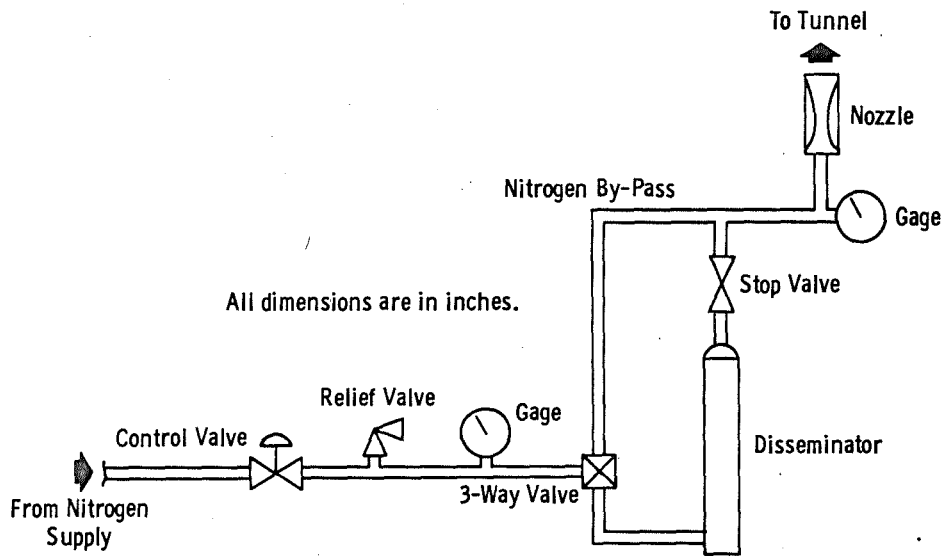

c. Particle Injection System

Fig. 3 Continued

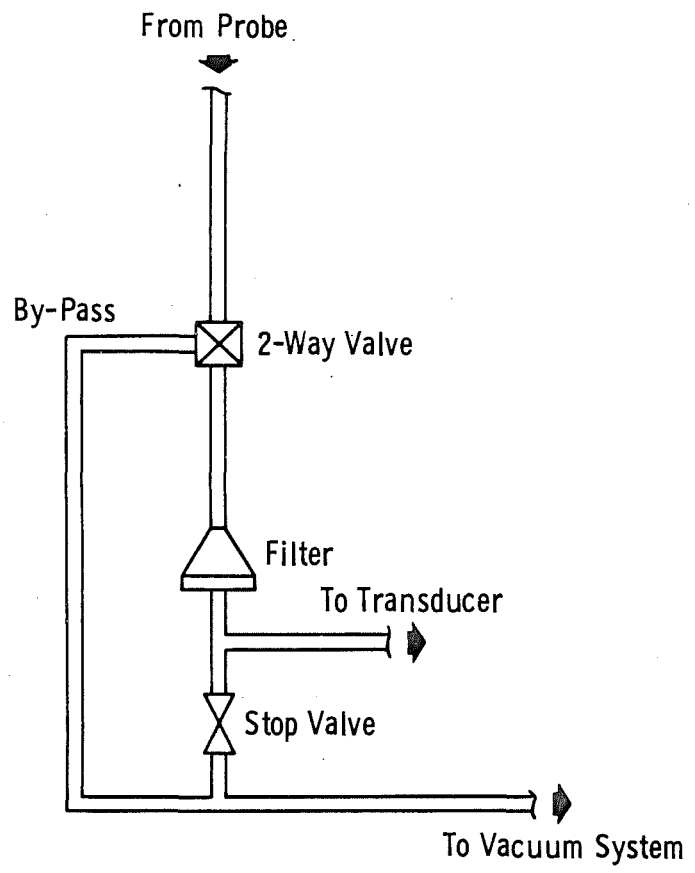

10

Note: There were fourteen filters, one for each probe on the rake and the "control probe."

All dimensions are in inches.

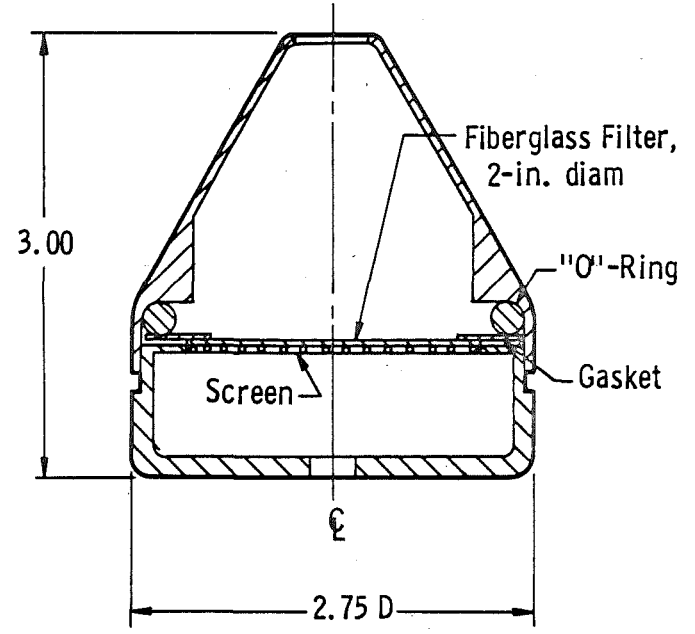

Filter Details

102729

d. Filter System
Fig. 3 Concluded

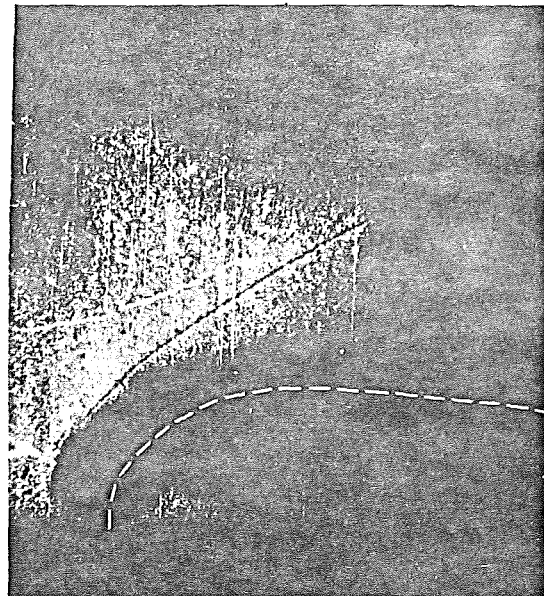

0 1 2 3 4
 x_p , in.

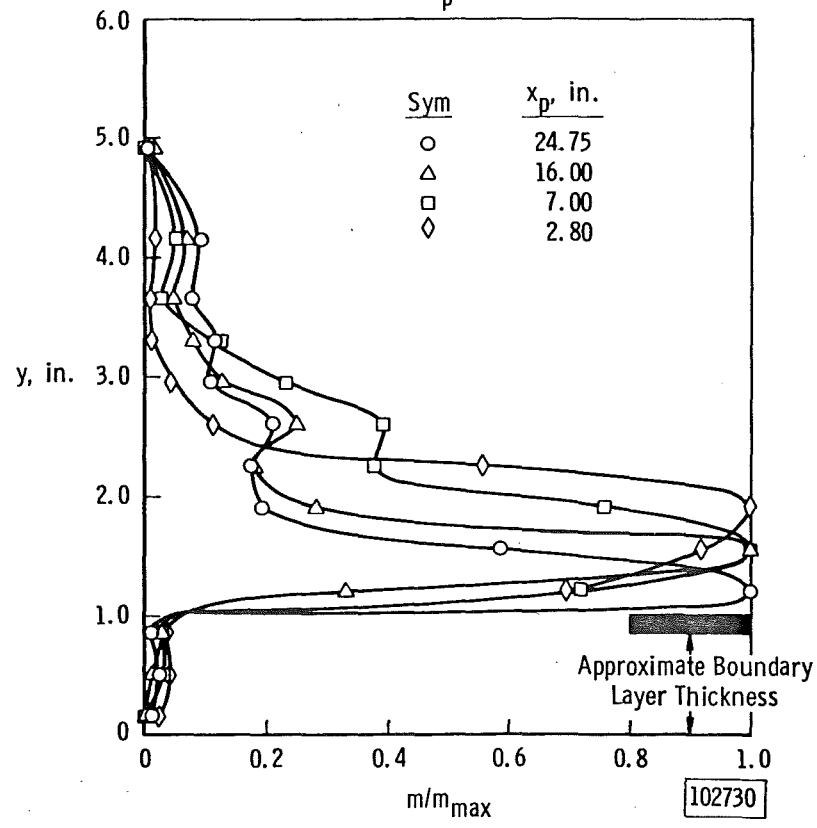

a. Variation of Nozzle Position; $d_i = 0.15$ in., $p_{o_i} / p_\infty = 60$
 Fig. 4 Particle Distribution on Tunnel Centerline at $M_\infty = 3$

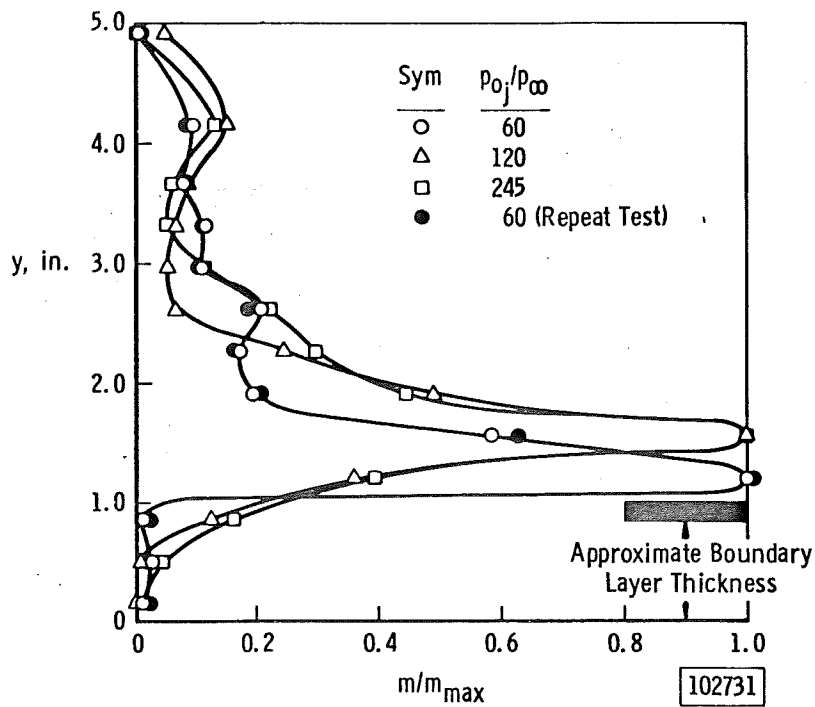

b. Variation of Jet Pressure Ratio; $d_j = 0.15$ in., $x_p = 24.75$ in.

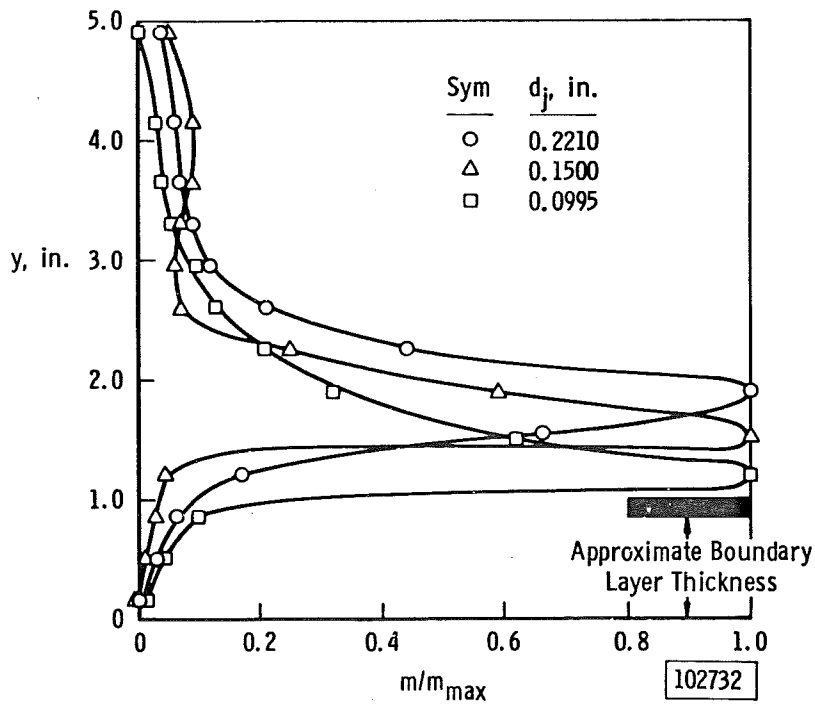

c. Variation of Nozzle Diameter; $p_{oj}/p_{\infty} = 120$, $x_p = 24.75$ in.

Fig. 4 Concluded