

UNCLASSIFIED

AD NUMBER
AD452191
NEW LIMITATION CHANGE
TO Approved for public release, distribution unlimited
FROM Distribution authorized to U.S. Gov't. agencies and their contractors; Administrative/Operational Use; Nov 1964. Other requests shall be referred to Bureau of Ships, Washington, DC.
AUTHORITY
USNSSC ltr, 16 May 1969

THIS PAGE IS UNCLASSIFIED

UNCLASSIFIED

AD_ 4 5 2 1 9 1

DEFENSE DOCUMENTATION CENTER

FOR

SCIENTIFIC AND TECHNICAL INFORMATION

CAMERON STATION ALEXANDRIA, VIRGINIA



UNCLASSIFIED

NOTICE: When government or other drawings, specifications or other data are used for any purpose other than in connection with a definitely related government procurement operation, the U. S. Government thereby incurs no responsibility, nor any obligation whatsoever; and the fact that the Government may have formulated, furnished, or in any way supplied the said drawings, specifications, or other data is not to be regarded by implication or otherwise as in any manner licensing the holder or any other person or corporation, or conveying any rights or permission to manufacture, use or sell any patented invention that may in any way be related thereto.

AD No. 452191

DDC FILE COPY

452191

W. H. Munse

CIVIL ENGINEERING STUDIES

STRUCTURAL RESEARCH SERIES NO. 285

✓ 9/1/52

PRIVATE COMMUNICATION
NOT FOR PUBLICATION



**STUDIES OF THE FATIGUE BEHAVIOR
OF BUTT-WELDED JOINTS
IN HY-80 AND HY-100 STEELS**

By

W. H. MUNSE
W. H. BRUCKNER
A. J. HARTMANN
J. B. RADZIMINSKI
R. W. HINTON
and
J. L. MOONEY

A REPORT OF AN INVESTIGATION CONDUCTED

by

THE CIVIL ENGINEERING DEPARTMENT
UNIVERSITY OF ILLINOIS

in cooperation with

THE BUREAU OF SHIPS, U.S. NAVY

Contract NOs 88058

Project Serial No. SR-007-01-01, Task 856

UNIVERSITY OF ILLINOIS
URBANA, ILLINOIS
NOVEMBER, 1964

DDC
DEC 8 1964
UNIVERSITY OF ILLINOIS

(5) *Final Report, 7/64*

(6)
STUDIES OF THE
FATIGUE BEHAVIOR OF BUTT-WELDED JOINTS
IN HY-80 AND HY-100 STEELS,

(10) by
W. H. Munse,
W. H. Bruckner,
A. J. Hartmann,
J. B. Radzinski *and*
R. W. Hinton

A Report of an Investigation Conducted
by
THE CIVIL ENGINEERING DEPARTMENT
UNIVERSITY OF ILLINOIS

(15) In Cooperation With
The Bureau of Ships, U. S. Navy
Contract N0bs 88058,
Proj. ~~SR-007-01-01~~ SR-007-01-01, Task 856
(16) ~~SR-007-01-01~~ (17)

J. B.

UNIVERSITY OF ILLINOIS
URBANA, ILLINOIS
NOVEMBER 1964

P. A.

SYNOPSIS

↓
The results of axial fatigue tests of transverse butt welded joints in HY-80 steel containing internal defects are reported. The tests were conducted on 3/4 in. and 1-1/2 in. thick material under stress cycles of zero-to-tension and complete reversal. The types of weld defects studied include porosity, slag inclusions, and artificially produced pores, and show that the existence of weld defects measurably decreases the fatigue life of a joint at a given stress cycle when compared to sound welded specimens (with reinforcement removed). However, there does not appear to be a simple correlation between type of defect or amount of defective area and fatigue strength.

As part of the study of weld defects, radiographic and ultrasonic techniques were employed to determine the time to initiation and propagation of fatigue cracks in welded joints. The results indicate that the first appearance of a macrocrack (visible on the radiographs) occurs at slightly more than half the test life. The subsequent crack propagation progresses slowly and erratically at first, but the rate of growth is rapidly accelerated from the time it reaches the specimen surface until complete failure occurs.

Metallurgical studies were conducted to examine the effect of restraint during welding on the formation of internal microcracks (sulfide inclusions) in welded joints, and the behavior of these joints under conditions of fatigue. ←
The studies indicate that the effects of metallurgical factors introduced by restraint during welding are less critical than internal weld flaws (porosity, slag, etc.) in reducing fatigue strength. ←

A preliminary study of the fatigue behavior of 3/4 in. thick HY-100 steel was completed. Tests were carried out on plain plate specimens and transverse butt welded joints in the as-welded condition using a zero-to-tension stress

Note to Typist: Delete as necessary if too long. Add as necessary.

cycle. Although the results for the plain plate specimens compared favorably with similar tests on HY-80 steel, the fatigue behavior of the welded joints in HY-100 was inferior to that of the HY-80 material. This is apparently due to a greater sensitivity of the HY-100 steel to external weld geometry and to the presence of even very small weld defects.

TABLE OF CONTENTS

	<u>Page</u>
I. INTRODUCTION	1
1.1 Object of Study	1
1.2 Scope of Investigation	1
1.3 Acknowledgments	2
II. DESCRIPTION OF TEST PROGRAM	3
2.1 Material	3
2.2 Fabrication of Specimens	3
2.3 Description of Test Equipment	4
2.4 Testing Procedure	4
2.5 Radiographic Studies	4
III. FATIGUE TESTS OF 3/4 INCH HY-100 MATERIAL	6
3.1 Introductory Remarks	6
3.2 Tests of Plain Plate Specimens	6
3.3 Tests of As-Welded Butt Joints	7
3.4 Data Analysis	8
IV. FATIGUE TESTS OF TRANSVERSE BUTT WELDS IN HY-80 MATERIAL HAVING INTERNAL DEFECTS	9
4.1 Introductory Remarks	9
4.2 Porosity in 1-1/2 In. HY-80 Specimens	9
4.3 Slag in 1-1/2 In. HY-80 Specimens	12
4.4 Fatigue Tests of Defective Welds in 3/4 In. HY-80 Material	13
4.5 Discussion of Results	14
V. CRACK INITIATION AND PROPAGATION	15
5.1 Introductory Remarks	15
5.2 Test Equipment and Testing Procedure	15
5.3 Initiation of Fatigue Cracks	16
5.4 Crack Propagation	19
5.5 Conclusions	22
VI. METALLURGICAL STUDIES OF WELDED HY-80 STEEL	24
6.1 Introductory Remarks	24
6.2 Experimental Procedures	25
6.3 Material Description	26
6.4 Distribution and Size of Sulfide Inclusions	26
6.5 Discussion	27
a. Hot Crack Geometry	28
b. Effect of Restraint of the Butt Weld on Hot Cracks	28
c. Effect of Sulfur Concentration on Hot Cracking	29

TABLE OF CONTENTS (cont'd)

	<u>Page</u>
d. Length of Hot Cracks	29
e. Metallographic Observations of Weld Metal Flaws	29
f. Inclusion Study	30
g. Effect of "Buttering" on the Frequency of Hot Cracks	30
h. Effect of Hot Cracks on Fatigue Life	31
6.6 Conclusions	33
VII. SUMMARY	35
7.1 Fatigue Behavior of HY-100 Steel	35
7.2 Weld Defect Study of HY-80 Steel	35
7.3 Crack Growth Study	36
7.4 Metallurgical Studies	36
7.5 General Summary and Conclusions	37 ✓
BIBLIOGRAPHY	39
TABLES	40
FIGURES	
APPENDIX A: Ultrasonic Crack Detection Study	A-1 ✓

LIST OF TABLES

<u>Number</u>		<u>Page</u>
2.1	PHYSICAL PROPERTIES OF BASE METAL	40
2.2	CHEMICAL COMPOSITION OF BASE METAL	41
3.1	RESULTS OF FATIGUE TESTS OF HY-100 PLAIN PLATE SPECIMENS	42
3.2	RESULTS OF FATIGUE TESTS OF HY-100 TRANSVERSE BUTT WELDS IN THE AS-WELDED CONDITION	43
3.3	SUMMARY OF FATIGUE TESTS OF HY-80 AND HY-100 MATERIAL	44
4.1	RESULTS OF FATIGUE TESTS OF TRANSVERSE BUTT WELDS IN 1-1/2 IN. HY-80 STEEL (Intentional Porosity in Weld)	45
4.2	RESULTS OF DEFECT EXAMINATION OF TRANSVERSE BUTT WELDS IN 1-1/2 IN. HY-80 STEEL (Intentional Porosity in Weld)	46
4.3	RESULTS OF FATIGUE TESTS OF TRANSVERSE BUTT WELDS IN 1-1/2 IN. HY-80 STEEL (Intentional Slag Inclusions in Weld)	47
4.4	RESULTS OF DEFECT EXAMINATION OF TRANSVERSE BUTT WELDS IN 1-1/2 IN. HY-80 STEEL (Intentional Slag Inclusions in Weld)	48
4.5	RESULTS OF FATIGUE TESTS AND DEFECT EXAMINATION OF TRANSVERSE BUTT WELDS IN 3/4 IN. HY-80 STEEL (Intentional Porosity and Slag)	49
5.1	RESULTS OF FATIGUE CRACK INITIATION AND PROPAGATION STUDY OF TRANSVERSE BUTT WELDS IN 3/4 IN. HY-80 STEEL CONTAINING INTENTIONAL WELD DEFECTS	50
6.1	MANGANESE, SULFUR, AND PHOSPHORUS CONTENT OF THE HY-80 STEEL PLATES	51
6.2	AVERAGE SIZE OF SULFIDE INCLUSIONS PER NUMBER MEASURED	52
6.3	NUMBER OF HOT CRACKS PER TRANSVERSE SECTION OF HY-80 STEEL EXAMINED	52
6.4	AVERAGE LENGTHS OF HOT CRACKS	53
6.5	LENGTH OF HOT CRACKS NOT ASSOCIATED WITH INCLUSIONS	53
A.1	RESULTS OF ULTRASONIC STUDY OF CRACK PROPAGATION	A-2

LIST OF FIGURES

<u>Number</u>	
2.1	DETAILS OF TEST SPECIMENS
2.2	WELDING PROCEDURE P80-11018-A
2.3	WELDING PROCEDURE P100-11018-J
2.4	WELDING PROCEDURE P80-11018-D
2.5	ILLINOIS' FATIGUE TESTING MACHINE AS USED FOR AXIAL LOADING OF WELDED JOINTS
3.1	TYPICAL PHOTOMICROGRAPHS OF TRANSVERSE BUTT WELD IN 3/4 IN. HY-80 MATERIAL
3.2	TYPICAL PHOTOMICROGRAPHS OF TRANSVERSE BUTT WELD IN 3/4 IN. HY-100 MATERIAL
3.3	RESULTS OF FATIGUE TESTS OF AS-ROLLED HY-100 PLAIN PLATE SPECIMENS
3.4	FRACTURE SURFACE OF AS-ROLLED HY-100 PLAIN PLATE SPECIMEN
3.5	RESULTS OF FATIGUE TESTS OF HY-100 TRANSVERSE BUTT WELDS IN THE AS-WELDED CONDITION
3.6	TYPICAL FRACTURES OF TRANSVERSE BUTT WELDS IN 3/4 IN. HY-100 MATERIAL
3.7	REDUCTION IN FATIGUE STRENGTH FROM AS-ROLLED PLAIN PLATES DUE TO A TRANSVERSE BUTT WELD IN THE AS-WELDED CONDITION
4.1	RESULTS OF FATIGUE TESTS OF 1-1/2 IN. TRANSVERSE BUTT WELDS CONTAINING VARIOUS AMOUNTS OF INTENTIONAL POROSITY (REINFORCEMENT REMOVED)
4.2	TYPICAL FRACTURES FOR 1-1/2 IN. TRANSVERSE BUTT WELDED JOINTS CONTAINING INTENTIONAL INTERNAL WELD DEFECTS
4.3	PERCENT FATIGUE STRENGTH AT 100,000 CYCLES VS. EFFECTIVE DEFECT DIAMETER OF POROSITY IN 1-1/2 IN. MATERIAL
4.4	COMPUTED FATIGUE STRENGTH AT 100,000 CYCLES VS. DEFECTIVE AREA DUE TO INTENTIONAL POROSITY IN 1-1/2 IN. MATERIAL
4.5	RESULTS OF FATIGUE TESTS OF 1-1/2 IN. TRANSVERSE BUTT WELDS CONTAINING VARIOUS AMOUNTS OF INTENTIONAL SLAG (REINFORCEMENT REMOVED)
4.6	COMPUTED FATIGUE STRENGTH AT 100,000 CYCLES VS. DEFECTIVE AREA DUE TO INTENTIONAL SLAG INCLUSIONS IN 1-1/2 IN. MATERIAL
4.7	COMPUTED FATIGUE STRENGTH AT 20,000 CYCLES VS. DEFECTIVE AREA DUE TO INTENTIONAL SLAG INCLUSIONS IN 1-1/2 IN. MATERIAL
4.8	FRACTURE SURFACE OF 3/4 IN. TRANSVERSE BUTT WELDED JOINT CONTAINING ARTIFICIAL INTERNAL WELD DEFECTS
4.9	COMPUTED FATIGUE STRENGTH AT 50,000 CYCLES VS. DEFECTIVE AREA DUE TO INTENTIONAL WELD DEFECTS IN 3/4 IN. MATERIAL
4.10	COMPUTED FATIGUE STRENGTH AT 100,000 CYCLES VS. DEFECTIVE AREA DUE TO INTENTIONAL WELD DEFECTS IN 1-1/2 IN. MATERIAL
5.1	SETUP FOR RADIOGRAPHIC STUDY OF CRACK PROPAGATION

LIST OF FIGURES (CONTD)

- Number
- 5.2 SETUP FOR ULTRASONIC STUDY OF CRACK PROPAGATION
 - 5.3 CORRELATION BETWEEN INITIAL LENGTH OF INTENTIONAL WELD DEFECT AND INITIATION OF FATIGUE CRACKS
 - 5.4 COMPARISON OF CYCLES OF FATIGUE CRACK PROPAGATION TO TEST LIFE IN 3/4 IN. HY-80 TRANSVERSE BUTT WELDED SPECIMENS TESTED AT ± 50.0 KSI
 - 5.5 COMPARISON OF CYCLES OF FATIGUE CRACK PROPAGATION TO TEST LIFE IN 3/4 IN. HY-80 TRANSVERSE BUTT WELDED SPECIMENS TESTED AT 0 TO +50.0 KSI
 - 5.6 RATE OF CRACK PROPAGATION IN 3/4 IN. HY-80 TRANSVERSE BUTT WELDED SPECIMENS TESTED AT ± 50.0 KSI
 - 5.7 RATE OF CRACK PROPAGATION IN 3/4 IN. HY-80 TRANSVERSE BUTT WELDED SPECIMENS TESTED AT 0 TO +50.0 KSI
 - 6.1 WELDING JIG USED TO RESTRAIN HY-80 STEEL DURING BUTT WELDING
 - 6.2 MAIN PLATE OF HY-80 STEEL FROM WHICH TEST PLATES G-67, G-68, AND G-69 WERE OBTAINED
 - 6.3 SECTIONING PLAN FOR METALLOGRAPHIC SAMPLES OF BUTT WELDED HY-80 STEEL
 - 6.4 TRANSVERSE SECTION OF A MULTIPASS BUTT WELD OF HY-80 STEEL
 - 6.5 HISTOGRAM OF THE WIDTH OF INCLUSIONS IN THE Z-87 and G-69 SAMPLES OF HY-80 STEEL
 - 6.6 HISTOGRAM OF THE THICKNESS OF INCLUSIONS IN THE Z-87 AND G-69 SAMPLES OF HY-80 STEEL
 - 6.7 PHOTOMICROGRAPH OF A LARGE CRACK IN THE HAZ AND WELD METAL OF BUTT WELDED HY-80 STEEL
 - 6.8 PHOTOMICROGRAPH OF THE SAME CRACK SHOWN ABOVE AFTER 0.009 IN. WAS POLISHED FROM THE TRANSVERSE SECTION
 - 6.9 PHOTOMICROGRAPH OF A LARGE CRACK NOT APPARENTLY ASSOCIATED WITH INCLUSIONS
 - 6.10 PHOTOMICROGRAPH OF CRACKS ASSOCIATED WITH POROSITY NEAR UNDERCUT REGION OF WELD
 - 6.11 PHOTOMICROGRAPH OF A LARGE CRACK ALONG THE "FINGER" OF THE WELD METAL THAT EXTENDS INTO THE BASE METAL
 - 6.12 MICROHARDNESS SURVEY OF 1-1/2 IN. THICK HY-80 STEEL BUTT WELD
 - 6.13 MICROHARDNESS SURVEY OF THE WELD METAL AND HAZ OF "BUTTERED" HY-80 STEEL SCARF
 - 6.14 FRACTURED SECTION OF HY-80 STEEL SAMPLE G-68 WELDED IN RESTRAINT
 - 6.15 TRANSVERSE SECTION OF FRACTURED SAMPLE INDICATED BY THE ARROW IN FIG. 6.14
 - 6.16 PHOTOMICROGRAPH SHOWING FATIGUE CRACKS RADIATING FROM POROSITY IN HY-80 STEEL SAMPLE G-68 AFTER 13,000 CYCLES OF ± 50.0 KSI

LIST OF FIGURES (CONTD)

Number

- A.1 RESULTS OF ULTRASONIC CRACK DETECTION STUDY FOR SPECIMENS TESTED
AT ± 50.0 KSI
- A.2 RESULTS OF ULTRASONIC CRACK DETECTION STUDY FOR SPECIMENS TESTED
AT 0 TO $+50.0$ KSI

I. INTRODUCTION

1.1 Object of Study

Since the previous studies^{(1,2)*} on fatigue behavior of welded joints in HY-80 steel sometimes produced failures that initiated in the weld at internal flaws rather than at changes in the external geometry, an extensive study of the fatigue behavior of 3/4 in. thick defective welded joints in HY-80 steel was undertaken in July 1962. In the present study, the effect of internal weld flaws on the fatigue behavior of 1-1/2 in. thick HY-80 welded joints has been evaluated and compared to that obtained for 3/4 in. specimens. In addition, the study of initiation and propagation of fatigue cracks was expanded to study the effect of defect type and stress cycle.

The second phase of the study has been concerned with a preliminary evaluation of the fatigue behavior of HY-100 steel. Two types of specimens were studied: as-rolled plain plate specimens, and butt welded joints in the as-welded condition.

The third phase of the study involved a metallurgical study of the effect of internal cracks (which initiate at sulfide inclusions), produced by restraint during welding, on the fatigue behavior of welded joints.

1.2 Scope of Investigation

The studies reported herein were carried out on plain plate and transverse butt welded specimens using stress cycles of zero-to-tension and complete reversal. The report covers tests conducted during the period of July 1963 to July 1964 and presents the results of a number of large scale fatigue tests.

* Numbers in parentheses refer to corresponding entries in bibliography.

Sixteen tests of 1-1/2 in. butt welded joints having slag and/or porosity were carried out under zero-to-tension stress cycles. In addition, a number of tests of 3/4 in. butt welded joints were conducted to study the effect of stress cycle (zero-to-tension and complete reversal), and type of internal weld flaw on the fatigue behavior of welded joints. These specimens were tested with the weld reinforcement removed.

Fatigue tests were carried out on plain plate and butt welded specimens fabricated from 3/4 in. HY-100 material. A zero-to-tension stress cycle was used for these tests.

Fatigue tests of butt welds fabricated under high welding restraint were used to study the effect of restraint on the development of internal weld cracks and their subsequent effect on the fatigue behavior of butt welded joints in HY-80 material.

1.3 Acknowledgments

The tests described in this report are the result of an investigation conducted in the Engineering Experiment Station of the University of Illinois. The program was carried out with funds provided by the Bureau of Ships, U.S. Navy, under Contract 88058, Project Serial No. SR-007-01-01, Task 856.

The investigation constitutes a part of the structural research program of the Civil Engineering Department of which Dr. N. M. Newmark is the head. The research was conducted by A. J. Hartmann, J. B. Radzinski, and J. L. Mooney, Research Assistants in Civil Engineering, under the direct supervision of W. H. Munse, Professor of Civil Engineering. The metallurgical studies were conducted by R. W. Hinton, Research Assistant in Metallurgical Engineering, under the direct supervision of W. H. Bruckner, Research Professor of Metallurgical Engineering.

The authors wish to express their appreciation to all the people on the Staff of the University who so ably assisted in the investigation.

II. DESCRIPTION OF TEST PROGRAM

2.1 Material

Two steels of different strength, HY-80 and HY-100, were used in this study; the HY-80 material was used in 3/4 in. and 1-1/2 in. thicknesses while the HY-100 material was used in 3/4 in. thickness. The physical and chemical properties of the materials are given in Tables 2.1 and 2.2, respectively.

The welding electrodes employed throughout the test program were of MIL 11018 grade. The electrodes were conditioned according to the requirements of the Navy Specifications⁽⁵⁾; a complete description of the procedure is given in Ref. (2).

2.2 Fabrication of Specimens

Figure 2.1 shows the geometry of the specimens tested in this test program. The specimen blanks, 9 by 48 in., were flame cut from larger sections of as-rolled HY-80 and HY-100 steel plates. The blanks used to fabricate transverse butt welded joints were cut in half and the sawed edges were beveled at 30 degrees to provide a double-V groove with a 60 degree included angle. The welding procedures that were used are given in Figs. 2.2 and 2.3 (3/4 in. thick material) and Fig. 2.4 (1-1/2 in. thick material). All welding was done in the flat position while the specimen blanks were clamped to a special welding jig. A stringer bead technique was used in placing successive passes and provides a heat treatment to the previously placed passes.

The holes necessary to hold the specimen in the testing machine were drilled and then the specimen blanks were machined to the desired

configuration (Fig. 2.1). In no case was material near the test section removed by flame cutting. After being machined, the edges of the specimens were ground and polished.

2.3 Description of Test Equipment

The tests were carried out using the University of Illinois' 250,000 lb. lever-type fatigue machines (Fig. 2.5); one of the machines was operated at 100 cpm while the other was operated at 160 cpm. There is a 15 to 1 force multiplication provided between the dynamometer and the test specimen by the lever system.

The throw of the eccentric determines the load range; i.e., the difference between the maximum and minimum loads. The value of the maximum load is set by means of the turnbuckle which is situated just below the dynamometer.

2.4 Testing Procedure

After the load had been set and the machine started, a microswitch was set so that the machine would shut off when a crack had propagated partially through the specimen. Failure was assumed to have occurred when the microswitch shut the machine off. The microswitch was then disconnected and the machine restarted; this was done to completely fracture the specimen so that the fracture surface could be examined and photographed.

2.5 Radiographic Studies

All specimens were subjected to radiographic examination prior to testing in order to determine the quality of the transverse butt welds. All "sound" weld specimens showed no weld defects to be present although a number of the specimens failed in the weld at minute weld flaws.

In addition, radiographs were taken at various stages of the tests of some 3/4 in. butt welded specimens of (HY-80) purposely provided with slag and porosity to evaluate crack initiation and propagation.

III. FATIGUE TESTS OF 3/4 INCH HY-100 MATERIAL

3.1 Introductory Remarks

Fatigue tests were carried out on plain plate and as-welded butt joint specimens of HY-100 material. During the past few years, the use of HY-100 has increased and as a result a knowledge of its fatigue behavior has become important.

The transverse butt welds were fabricated using welding procedure P100-11018-J, which is identical to procedure P80-11018-A used for the HY-80 material; no difficulty was encountered in the welding of the HY-100 material. The weldor and the welding procedure were qualified in accordance with requirements given in Ref. (5) for HY-80 material. The joint was able to undergo a 180° guided side bend test without cracking. Figures 3.1 and 3.2 show typical micrographs for the HY-80 and HY-100 materials, respectively; the microstructures of these materials are very similar.

3.2 Tests of Plain Plate Specimens

The results of the fatigue tests of plain plate specimens on a zero-to-tension stress cycle are tabulated in Table 3.1 and plotted in Fig. 3.3. The S-N curve shown in this figure for HY-100 material was obtained using the procedure outlined in Ref. (2). In addition, Fig. 3.3 contains the S-N curve for 3/4 in. HY-80 plain plates⁽⁴⁾. Comparing the curves it is noted that the slope for the HY-100 material is greater than that for the HY-80 material. However, only a limited number of tests were included in the study.

In a number of tests, failure initiated at the mill scale surface near the radius of the test section rather than at the radius of the test section. These failures initiated about 1/8 to 1/4 in. from the machined edge;

Fig. 3.4 shows this type of failure. The results tabulated in Table 3.1 indicate that the test lives were not influenced by the mode of failure. One of the specimens, HY-5, failed due to fretting in the upper pullhead after 396,500 cycles. The fretting cracks initiated at the drilled holes in the pullheads; examination of the area around the holes showed that the edges of the holes were very rough. A new pullhead was welded to the specimen and a total life of 546,300 cycles was obtained before failure occurred.

Comparing the average S-N curves for the HY-100 and HY-80 material, one may note that although the fatigue strength of HY-100 is greater than the fatigue strength of HY-80 for lives of less than 150,000 cycles, the situation is reversed at longer lives.

3.3 Tests of As-Welded Butt Joints

The results of the fatigue tests of as-welded butt joints on a zero-to-tension stress cycle are tabulated in Table 3.2 and plotted in Fig. 3.5. Figure 3.5 also contains the S-N curve for 3/4 in. HY-80 as-welded butt joints⁽⁴⁾. Although the 3/4 in. HY-80 specimens all failed due to the stress concentration of the external weld geometry, this was not true for the HY-100 material. In a number of cases, failure occurred in the weld rather than at the edge of the weld reinforcement because of very small defects which were present in the root area of the weld. These defects (Fig. 3.6) were not visible on the radiographs taken of the as-welded specimens prior to testing. Even on the fracture surface, it was difficult to locate the defects because of their smallness.

It can be seen on Fig. 3.5 that there was a large amount of scatter in the test results when failure occurred in the weld. In addition the failures propagated rapidly when they originated in the weld. When failure occurred in

the weld, the fatigue lives were less than those for HY-80 material by a factor of about 8.

Even when failure was due to the external weld geometry, the fatigue behavior of the HY-100 material was inferior to that of the HY-80 material. Between 40,000 and 400,000 cycles the lives of the two materials, at a given stress level, varied by a factor of 2 to 3. The difference increased with increasing life.

3.4 Data Analysis

Table 3.3 lists the fatigue strengths and slopes of the S-N curves for 1-1/2 and 3/4 in. HY-80 and 3/4 in. HY-100 materials.

Although the fatigue strength of the HY-100 plain plate specimens is slightly greater than that of the HY-80 for short lives (less than 100,000 cycles), it is slightly less than that of the HY-80 for longer lives. In the case of transverse butt welds, the behavior of the HY-100 joints is inferior to that of the HY-80 joints and the slopes of the S-N curves for HY-100 material are larger than the corresponding slopes of the HY-80 material, indicating that the HY-100 steel is more notch sensitive in fatigue than HY-80.

Figure 3.7 shows the reduction in fatigue strength resulting from the inclusion of the welded joints as a function of life for the HY-80 and HY-100 steels. The decrease in fatigue strength due to welding HY-100 is 35 percent at $N = 50,000$ cycles and 43 percent at $N = 200,000$ cycles. For 3/4 in. HY-80 material, the reduction was 8 percent at $N = 50,000$ cycles and 19 percent at $N = 200,000$ cycles, again showing the increased fatigue notch sensitivity of the HY-100 steel.

The HY-100 butt welded joints were very sensitive to the presence of internal defects. No tests were conducted with the weld reinforcement removed since most welds would contain minute weld defects and little or no increase in life could be expected.

IV. FATIGUE TESTS OF TRANSVERSE BUTT WELDS IN HY-80 MATERIAL HAVING INTERNAL DEFECTS

4.1 Introductory Remarks

Fatigue tests were carried out on a number of defective butt welded specimens in two thicknesses of HY-80 steel (3/4 in. and 1-1/2 in.) using two stress cycles (complete reversal and zero-to-tension). The weld reinforcement was removed on all specimens to improve defect definition on the radiographs taken of each specimen and to remove any effect of the weld reinforcement on the fatigue behavior.

The porosity and slag defects in the 3/4 in. thick specimens were produced as described in Ref.(4). However, some experimentation was necessary to produce the larger amounts of slag and porosity desired in the 1-1/2 in. specimens. This was necessary because the increased thickness required larger defect areas to provide defects of the maximum size permitted by Navy Specifications⁽⁵⁾.

In addition, several 3/4 in. thick transverse butt welded specimens were fabricated with artificial defects (steel balls) in the root area of the weld. The procedure had been reported previously⁽⁴⁾.

4.2 Porosity in 1-1/2 in. HY-80 Specimens

The results of fatigue tests of 1-1/2 in. defective butt welds are tabulated in Table 4.1 and plotted in Fig. 4.1. Since the tests were carried out using two stress cycles, 0 to +70.0 ksi and 0 to +50.0 ksi, it was possible to draw the S-N curve which is shown in Fig. 4.1. The slope, $k = C^{-1}$, is larger than that for sound butt welds with weld reinforcement removed but is less than that for butt welds tested in the as-welded condition. The S-N curves for sound butt welds with and without weld reinforcement are also given

in Fig. 4.1 Comparing the three curves one may see that although the curve for defective welds lies entirely below that for welds with reinforcement removed, it is below the curve for as-welded joints for lives less than 150,000 cycles but above the curve for higher lives. This indicates that at long lives the external geometry is more critical, with respect to fatigue, than internal defects when the defects are of a size permitted by the code; at the shorter lives the internal defects produce greater effects than the external geometry.

The geometry of the porosity in the 1-1/2 in. thick material was similar to that of the 3/4 in. thick material which was discussed extensively in a previous report⁽⁴⁾. The majority of natural defects were roughly spherical or ellipsoidal, Fig. 4.2a. The minimum distance from the surface of the weld to the porosity ranged from 7/16 in. to 9/16 in. for the 1-1/2 in. thick material and 7/32 in. to 5/16 in. for the 3/4 in. thick plate. All specimens in the present test series with natural porosity were fabricated to produce a single cluster of porosity. Specimens G-81 and G-88 each had fatigue cracks that grew from the main cluster of porosity as well as from other small defects located some distance from the cluster. Specimen G-81 had the lowest life and specimen G-88 had the longest life of the specimens tested at 0 to +50.0 ksi.

The pore diameters in most of the test welds ranged from 1/64 in. to 3/64 in. The effective defect diameter^{*}, d_e , was determined for the largest flaw in any cluster that propagated to failure and is tabulated in Table 4.2. Figure 4.3 shows a plot of the percent of $F_{100,000}$ for a sound weld with the reinforcement removed vs. the effective defect diameter; over the small range

* Effective defect diameter $d_e = \sqrt{d_1 d_2}$, where d_1 and d_2 = dimensions of major and minor axes of pore. The maximum value of d_e is listed in Table 4.2 for all specimens.

of values studied there does not appear to be any consistent variation in fatigue strength with the defect parameter, d_e . This is in contrast to the results obtained for 3/4 in. material where an increase in effective defect diameter produced a decrease in $F_{100,000}$. Nevertheless, it may be seen that the welds with maximum defects ranging from 0.035 to 0.067 in. in diameter had fatigue strengths at 100,000 cycles of approximately 65 percent of that for a sound weld.

Another parameter that has been used to specify the amount of porosity is the percentage of defective area in the gross area of the specimen, A_{red} . The defective area is defined as the area of porosity in the group or groups propagating to failure as measured on the fracture surface or as measured from the radiograph assuming that the porosity is uniformly distributed in a spherical manner. The A_{red} for a specimen was usually somewhat greater when based on the fracture surface than when based on radiographs because of the difficulty of interpreting the radiographs.

The average A_{red} for the 1-1/2 in. thick specimens was approximately equal to 0.16 percent; this is approximately the same as that obtained for the 3/4 in. thick specimens tested previously. The parameter, A_{red} , (based on the radiographs) is plotted vs. $F_{100,000}$ in Fig. 4.4. There is a little scatter in the test results, and no consistent decrease in fatigue strength with increasing A_{red} is evident for $0.02 < A_{red} < 0.25$ percent. This is unlike the case for 3/4 in. material for which a trend of decreasing fatigue strength with increasing defective area was evident.

Table 4.2 also indicates whether welds satisfy Naval Specifications⁽⁵⁾. Only two of the members failed to meet the Specification requirements but all of the members exhibited fatigue strengths considerably below that of a sound weld.

4.3 Slag in 1-1/2 In. HY-80 Specimens

The results of fatigue tests of transverse butt welds having slag inclusions in the weld are tabulated in Table 4.3. Since the tests were carried out using two stress cycles, it was again possible to obtain an S-N curve for the test results. The test results are shown in Fig. 4.5. In addition to the S-N curve for the defective welds, Fig. 4.5 contains the S-N curves for sound transverse butt welds in the as-welded condition and with the weld reinforcement removed. It is notable that the slope of the S-N curve for welds with slag inclusions is the same as that for porosity specimens ($k = 0.21$). (One of the specimens, G-90, failed due to the presence of a small slag deposit although the radiograph indicated only porosity.)

Figure 4.6 shows the fatigue strength at 100,000 cycles as a function of the percentage of defective area, A_{red} , (based on radiographs). The values of A_{red} , based on radiographs and on fracture surfaces are tabulated in Table 4.4; this table also indicates whether the welded joints satisfy Navy Specifications⁽⁵⁾. Unlike the case for 3/4 in. thick material where an increase in defect area was accompanied by a decrease in fatigue strength, there does not appear to be a similar trend for 1-1/2 in. material. As shown in Fig. 4.6 the zero-to-tension fatigue strength at 100,000 cycles varies between +37 ksi and +50 ksi, independent of the value of A_{red} , while the average fatigue strength for as-welded transverse butt welded joints is +46 ksi and for sound welded joints with the reinforcement removed is +64 ksi. The scatter for as-welded joints is +38 ksi to +48 ksi, which is essentially the same as for welds with internal defects. In some cases, welded joints not meeting the weld quality requirements of the Navy Specifications had higher fatigue strengths than those which did meet the requirements (see specimens G-91 vs. G-92 and G-93 in Table 4.3, and specimens Z-96 and Z-94 vs. Z-56, Z-74 and Z-95 in Table 4.5).

When the fatigue strength at 20,000 cycles is considered, Fig. 4.7, the effect of internal geometry on the fatigue life becomes more important. At this life, the upper bound of the results for defective welds is about 6 ksi lower than the average fatigue strength of the sound as-welded joints.

4.4 Fatigue Tests of Defective Welds in 3/4 In. HY-80 Material

Three transverse butt welded specimens, Z-100, Z-101, Z-102, containing artificial porosity (drilled holes filled with steel balls), were tested to study the effect of the spacing and number of defects in a line on the fatigue life. However, it was not possible to obtain fully the desired information since Z-100 failed due to lack of fusion in the root area rather than at drilled holes. The lives for these three specimens are given in Table 5.1 of the propagation study.

Specimen Z-102, which had eleven 1/16 in. diameter balls spaced at approximately 3 hole diameters, had a relatively long fatigue life for a specimen with A_{red} equal to 1.2 percent. This can be attributed to the widely distributed defect area and to the shape of the defects. Only six of the steel balls were included in the initial fatigue portion of the crack which propagated to failure (Fig. 4.8).

A number of 3/4 in. butt welded joints having internal weld defects were tested using a ± 50.0 ksi stress cycle. The test results are tabulated in Table 4.5; some of the complete reversal tests previously reported in Ref. (4) are also included. The fatigue strength at 50,000 cycles has been plotted as a function of the percentage of defective area, A_{red} , in Fig. 4.9. It does not appear that the fatigue strength is a function of the defect area. Furthermore, the upper bound of the scatter band for defective welds is about 12 ksi below the average fatigue strength for sound as-welded butt joints.

4.5 Discussion of Results

The fatigue strengths at 100,000 cycles vs. A_{red} for 1-1/2 in. transverse butt welds shown in Figs. 4.4 and 4.6 have been summarized in Fig. 4.10. The graph indicates that, for the range of intentional defects studied, the effect on the fatigue strength is independent of the type of defect and the amount of defective area. It is evident also that at 100,000 cycles the fatigue strength of the members with intentional flaws is about the same as that of the as-welded joints with the reinforcement in place (no intentional defects).

From the study reported above, it appears that the intentional internal weld defects in specimens with the weld reinforcement removed are of more importance than the external geometry of sound as-welded joints at shorter lives, less than 100,000 cycles, while the external weld geometry appears to be more important at the longer lives. It is also evident that the present code requirements for porosity and slag will not guarantee a fatigue behavior for 1-1/2 in. thick butt joints comparable to that of a sound joint. Neither does there appear to be any correlation, within the specifications, between fatigue strength and the defect size or area visible on radiographs.

Unlike the results obtained for zero-to-tension tests of defective 3/4 in. butt welded joints, there does not appear to be any change in the fatigue strength at a given life with an increase in the percentage of defective area, A_{red} , for complete reversal tests.

V. CRACK INITIATION AND PROPAGATION

5.1 Introductory Remarks

The fatigue life of metals may be divided into two general categories: the number of cycles required to initiate a fatigue crack* or cracks at a given stress level, and the cycles of crack propagation from initiation to failure. As part of the present study, nine 3/4 in. thick HY-80 transverse butt welded specimens, Z-94 through Z-102 inclusive, were examined during testing by using both radiographic and ultrasonic techniques to determine the time to crack initiation and subsequent propagation. Five specimens were tested at ± 50.0 ksi while the remaining four were tested at 0 to +50.0 ksi. Each of the specimens contained weld defects, the defects varying in type and size as shown in Table 5.1. The data for three specimens from an earlier study⁽⁴⁾, Z-70, Z-79, and Z-80, are also included in the results.

5.2 Test Equipment and Testing Procedure

All specimens in this series were tested in the University of Illinois' 250,000 lb. fatigue machine described earlier. To study crack initiation and propagation, two separate techniques were followed. The first employed the use of the portable radiographic equipment shown in Figs. 5.1a and 5.1b. The second method, used primarily for a qualitative comparison with the radiographic technique, utilized the ultrasonic flaw detection equipment shown in Figs. 5.2a and 5.2b.

Each of the specimens was x-rayed prior to testing to determine the size and location of internal weld defects. The specimen was next secured in

* Crack initiation - estimated herein as one-half the number of cycles between last radiographic observation showing no crack and first radiograph showing crack.

the fatigue machine and subjected to repeated loadings (the number of cycles depending on stress cycle) at which time the machine was shut off with the specimen being held at maximum tensile load. With the specimen in this position, a radiograph was then taken of the test section. Following this, the ultrasonic flaw detector, employing both a normal probe and a 45° angle probe, was used to scan the specimen through the region in which the weld was situated. For each of eight consecutive locations along the surface of the test section, the amplitude of the peak response as indicated on the detector scope for a constant pulse energy was recorded. No attempt was made to correlate these readings with actual flaw sizes; the method was used simply to obtain preliminary data concerning the feasibility of using such a device to detect the initiation of a fatigue crack. The results of the ultrasonic detection study are presented and briefly discussed in Appendix A.

If the radiograph showed no fatigue crack in the test section the procedure above was then repeated. This process continued until such time as a crack became evident, after which radiographs and ultrasonic readings were repeated at every 500 to 1000 cycles until the specimen failed.

5.3 Initiation of Fatigue Cracks

This phase of the investigation consisted of a study, using radiographic detection of the initiation of fatigue cracks in the 3/4 in. thick HY-80 butt welded specimens. The test specimens contained various types of weld defects; these defects were generally placed in the second weld pass and were located approximately midway between the specimen faces. The objectives of the investigation were twofold: (1) to determine whether, at a given stress level, some direct correlation exists between the type or size of weld defect and the initiation of a fatigue crack; and (2) to determine if there is some

simple relationship between the cycles to initiation and the specimen "test life".* It should be clearly understood that, for the purposes of this study, initiation is taken as the first appearance of a visible crack (macrocrack) as shown by the radiographs using the procedure outlined above. The significance of correlating initiation with test life rather than cycles to failure will be discussed in the section on crack propagation.

For the five specimens tested at ± 50.0 ksi, the life for fatigue crack initiation varied from a low of 1,400 cycles for specimen Z-99 to a maximum of 9,000 cycles for Z-94. A similar wide variation in cycles to initiation was exhibited by the specimens tested at 0 to +50.0 ksi. The life for initiation ranged from 2,500 cycles for Z-100 (an admittedly very poor specimen containing large initial weld defect) to 106,000 cycles for Z-98. Data for all the specimens appears in Table 5.1.

The large amount of scatter at both stress levels indicates that the existence of weld defects has a pronounced effect on the resistance of a specimen to crack initiation. It is assumed that the geometric configurations of these defects create high stress concentrations that produce plastic deformations in the vicinity of the flaws, thereby leading to the eventual initiation of fatigue cracks. That such is the situation was evident from an examination of the sequence of radiographs taken of each specimen. Visible fatigue cracks would almost invariably originate at the extremities of a weld defect, although not necessarily at the largest defect. This was in marked contrast to $3/4$ in. thick sound weld specimens (with reinforcement removed) where fatigue cracks frequently had their origins outside the test section.

* Test life - defined herein as the number of cycles necessary for a crack to propagate to the surface of the test specimen.

The type and size of weld flaw leading to fatigue crack initiation for each specimen is compared with cycles to initiation in Fig. 5.3. For those specimens tested at 0 to +50.0 ksi, the general behavior appears to be toward decreased cycles to initiation as size (length) of weld defect increases. At ± 50.0 ksi, however, this tendency is not evident. It was not possible to determine the geometry at the extremity of the weld defects from the single radiograph taken at each life.

From these tests, it appears that no single weld defect parameter in itself controls the fatigue crack initiation. Rather, it is probably the combined effect of a number of factors that creates the condition necessary to initiate cracking under a given stress cycle. These factors include: (1) size and geometry of weld defects; (2) number and type of defects in weld area; (3) location of defects in specimen (i.e., proximity to other flaws or specimen surface); (4) orientation of defects with respect to direction of loading; and (5) the residual stresses in the weld metal. Without more data, the inter-relationships between the critical variables defies analytical description, thus pointing to the necessity of continued extensive study of all factors using a statistical approach. The problem is further complicated by the difficulty encountered in trying to create isolated defects of various types, shapes, and sizes in a specimen.

As might be anticipated from the wide range of cycles to crack initiation in specimens at both stress levels, there was no consistent relationship between the cycles to initiation and the test life. At ± 50.0 ksi, the ratio of cycles to initiation to test life varied from 0.264 for specimen Z-99, to 0.833 for Z-94 (Table 5.1). For the specimens tested at 0 to +50.0 ksi, the variation in this ratio ranged from 0.462 for specimen Z-80 to 0.922 for Z-102. The cracks in the majority of specimens, however,

initiated at more than half the test life, with the average for all specimens being 0.69. Thus, on the basis of these tests and the crack detection procedure used, the number of cycles necessary to propagate the fatigue cracks to the specimen surface was found to be less than 50 percent of the test life.

5.4 Crack Propagation

The process of propagation of a crack initiating at an internal weld defect in the 3/4 in. thick plate specimens can be divided into two reasonably distinct regions. The first stage begins with the initiation of the crack and continues until the crack approaches or actually intersects the specimen surface (test life). It is during this period that the specimen experiences true "fatigue crack" propagation, with the crack growing radially from the defect and in a plane normal to the direction of loading. Thereafter, the mode of propagation in the joints changes to one in which the crack progresses along planes oblique to the loading direction, exhibiting the so called "shear-type" crack growth behavior illustrated in detail in a earlier report⁽⁴⁾. The rate of propagation is rapidly accelerated during this latter stage and ends with complete fracture within a relatively few cycles. This increased rate of growth is due in large part to the higher stresses created as the remaining net specimen section required to resist the load is decreased. The extent of both modes of crack propagation can be easily distinguished by visual observation of a specimen fracture surface, such as that shown in Fig. 4.8.

The importance of test life rather than cycles to complete failure as a measure of fatigue behavior now becomes apparent. It is the test life that most accurately represents the limit of extension of a true fatigue crack in a plate specimen of the type used in this study, thus providing a

consistent bound for evaluating the radiographic data regarding such crack growth. It was the purpose of this phase of the project to investigate both the fatigue and shear-type crack growth mechanisms and to correlate duration and rate of propagation with test-stress conditions. A discussion of the observations is presented below.

The number of cycles of propagation from initiation to test life, for the specimens tested at ± 50.0 ksi, varied from 1000 cycles for specimen Z-97, to a maximum of 4,500 cycles for Z-96. There was an apparent general trend but no clearly defined consistent ratio between duration of fatigue crack growth and specimen life. Rather, Fig. 5.4 shows that the number of cycles of propagation falls within a fairly narrow band regardless of the total life of the specimen. This observation is even more pronounced for the tests performed at 0 to +50.0 ksi, when all of the tests are considered. However, as shown in Fig. 5.5, the cycles of fatigue crack propagation for the current series of tests ranged from 2,700 for specimen Z-100 to 14,000 for Z-98, and show an increase in duration of crack propagation with an increase in test life, although the increase is not great. The specimens from the previous tests had greater durations of propagation even though their total lives were lower.

That the duration of fatigue crack propagation should be approximately constant at a given stress level may be reasoned by a closer observation of the crack appearance. Although the geometric configurations of internal weld defects do vary considerably (thus affecting initiation), once a fatigue crack forms and begins to extend radially outward from the defect, the geometry at the tip of the crack becomes similar in most cases. The specimens then continue to undergo essentially constant fatigue crack growth up to the point of intersection with the specimen surface, when the mode

changes to the shear-type mentioned above. Since the crack-initiating defects were located near the center of the weld in the specimen and all specimens in the group tested were 3/4 in. thick, it appears reasonable that they should exhibit similar propagation times as, indeed, is substantiated by the information presented in Figs. 5.4 and 5.5. The slight increase in duration of propagation with test life may be due to such factors as variation in flaw location, the residual stresses in the weld, etc.

The second objective of this study on propagation was to investigate the actual rate of crack propagation, during both the normal fatigue and shear-type growth stages. The results of measurements from the radiographs are presented in Figs. 5.6 and 5.7 for tests performed at ± 50.0 ksi and 0 to $+50.0$ ksi respectively. The data are referred to test life, thus differentiating the two separate stages of propagation. Although the scatter band for crack length prior to the test life appears to indicate a uniform rate of growth, tracing the data for an individual specimen tends to indicate a stepped pattern of propagation, especially in the tests at 0 to $+50.0$ ksi. This system of alternating periods of growth and dormancy or near dormancy has been reported in the literature^(6,7) and appears to be fairly common behavior in the early stages of fatigue crack propagation. The limited number of observations in these tests, however, precludes any estimate of the number or duration of these dormant periods.

In the zero-to-tension tests this step-type growth pattern continued in some specimens for a time beyond the appearance of the crack on the specimen surface. Thereafter, the growth rate accelerated rapidly and failure usually occurred within few additional cycles. Figures 5.6 and 5.7 do, however, show a considerable range of cycles from test life to failure. Although no conclusions have been drawn concerning this variation in duration of crack

propagation at each stress cycle, two possibilities are offered. First, the planes that the crack follows after reaching the specimen surface are often dictated by the location of other weld flaws in the near vicinity. The crack will tend to grow toward these defects, especially if they, too, have initiated fatigue cracks. If no such additional defects exist, the crack often passes near or into the specimen heat affected zone and follows that line to failure. Depending upon the crack path taken, the crack will progress through the test section at a slower or more rapid rate. A second possibility would be the location of the propagating crack in the specimen cross-section. A crack situated toward the edge of the specimen would tend to induce bending as well as axial stresses in the remaining net section, thus increasing the wedging action at the tip of the crack and further stimulating the rate of propagation.

5.5 Conclusions

Based on the study reported herein, the following conclusions have been drawn regarding the initiation and propagation of fatigue cracks in 3/4 in. thick HY-80 transverse butt welded specimens containing weld defects:

1. At a given stress cycle, there is no consistent number of cycles for the initiation of a macroscopic fatigue crack; nor is there a constant ratio between cycles to initiation and test life (appearance of crack on specimen surface). The number of cycles required to initiate such a crack is apparently strongly dependent upon several critical parameters including:
a) type, quantity and geometry of internal weld defects; and b) location of defect in weld (whether in a tensile or compressive residual stress zone), and orientation with respect to direction of loading.
2. After the initiation of a fatigue crack at or in the vicinity of a weld defect, the duration of its propagation to test life falls within a

fairly narrow range of cycles for a given stress level. This period defines a region of "fatigue crack" propagation. In the present series of tests this crack propagation ranged from 1,000 to 4,500 cycles for specimens tested at ± 50.0 ksi and from 7,000 to 14,000 cycles (excluding Z-100) for those tested at 0 to +50.0 ksi. In most cases the mechanism of early crack propagation appeared to follow a stepped pattern of intermittent periods of growth and dormancy rather than a constant or uniformly varying rate.

3. Beyond the point at which the crack reaches the specimen surface, the increased stresses near the tip of the crack and throughout the entire remaining net section cause a rapid increase in the rate of crack growth leading to failure within a relatively few cycles. During this period of crack propagation, the path of the crack usually progresses along planes oblique to the direction of loading. This pattern then continues until complete fracture of the specimen takes place.

VI. METALLURGICAL STUDIES OF WELDED HY-80 STEEL

6.1 Introductory Remarks

In the previous study⁽⁴⁾ on the effect of weld flaws on the fatigue behavior of butt welded joints in HY-80 steel fatigue crack propagation was observed. These fatigue cracks propagated either along the fusion line, in the weld metal or in the base metal. Frequently the crack propagation in the base metal was observed along metal-inclusion boundaries. In a few cases, the inclusions were melted near the fusion line leaving small hot cracks in that region.

Because of the above observations the inclusions were suspected of causing early fatigue failures when they produced hot cracks in the base metal near the fusion line of the weld. These inclusions were tentatively identified as sulfides because of their low melting point and their metallographic appearance.

The metallurgical studies of weldments in HY-80 steel in this report involved three main objectives:

- (a) To develop quantitative relationships between the size of sulfide stringer inclusions and their contribution to hot cracking in a weldment.
- (b) To determine the separate contributions of the sulfides and the stresses during welding on the initiation of cracks in the weld deposit and heat affected zone of the base metal.
- (c) To determine the efficacy of changes in welding procedure on the reduction or elimination of hot cracking in the deposited weld metal.

After reproducible hot crack production in butt welded HY-80 steel was attained, fatigue tests were performed on these joints.

6.2 Experimental Procedures

Restraint was applied to the HY-80 steel during butt welding in order to develop a number of hot cracks. Welding procedure P80-11018 was used to make the joints. The 30° double "V" grooves for normal butt welded samples were cut in 3/4 in. and 1-1/2 in. thick HY-80 steel plates, with a 1/8 in. spacing between the plates at the root. Two 4-1/2 in. x 9 in. plates were then placed in a 17 in. square block of 2 in. thick plain carbon steel as shown in the diagram in Fig. 6.1. Both HY-80 steel plates were then fillet welded into the plain carbon steel plate at both surfaces to produce maximum restraint conditions during the butt welding. The longitudinal restraint was decreased to some extent by fillet welding the HY-80 plates only in the direction parallel to the long axis of the butt weld. After the butt weld was completed, it was allowed to remain under restraint for a minimum of 24 hours after the butt welding. The fillet welds were initially checked by dye penetrant for possible surface cracking but none was observed.

Since the hot cracks could not be determined by x-ray radiography, the samples were examined by metallurgical sectioning, polishing, and etching. The length and position of the hot cracks were recorded. The sample was then repolished and the hot cracks were again observed in order to check the first observation.

A diagram of the test plate positions in the original HY-80 steel plate is shown in Fig. 6.2. The test plates were cut into 9 in. wide strips for test purposes. The butt weld was approximately 8 inches long in the 9 in. "V" groove, but only the middle 6 inches of each butt weld was examined for hot cracks. Metallographic sections were cut from the weld as shown in Fig. 6.3 after each butt weld was held in restraint for a minimum time of

24 hours. The optimum observations of hot cracks were made at a magnification of 400 diameters.

6.3 Material Description

The HY-80 steel was received in the quenched and tempered condition and was welded in this condition for the metallurgical studies.

The chemical composition of each of the two HY-80 heats used in this investigation is listed in Table 2.2 as given by the "Mill Report." An analysis for manganese, phosphorus and sulfur in each plate near the 3/4 in. plate surface and at its mid-thickness is given in Table 6.1. An average of the results found in Table 6.1 will be used to represent the G-67, G-68, G-69, and Z-87 plates. The G-69 plate was cut down from a 1-1/2 in. thick plate by removing 3/8 in. from each side in order to obtain a 3/4 in. thick plate of a higher sulfur composition. The Z-87 plate had been rolled down to its 3/4 in. thickness at the mill.

The G plates represent a higher sulfur content and were taken from the bottom center of the ingot (plate A-5) as shown in Fig. 6.2. Since the main rolling direction was known, a reasonably perpendicular cross-section of the inclusions could be obtained. A direct measurement of the inclusion's width and thickness for the G-69 and Z-87 plates was made at 300x.

6.4 Distribution and Size of Sulfide Inclusions

An average size for the inclusions was recorded by measuring the widths and thicknesses of a number of inclusions in a section of the plate transverse to the rolling direction at 300 diameters magnification. The widths of the inclusions in the Z-87 plate were greater than those in the G-69 plate on the average, but the thickness of the inclusions in the Z-87 sample was less than those of the G-69 sample. If an average area of

inclusion perpendicular to the rolling direction is calculated, assuming a rectangular area, the average inclusion area in the Z-87 plate was 165 square microns compared to 83 square microns for the G-69 plate inclusion area. Table 6.2 lists the results of this study and shows the difference in the inclusions in the G-69 and Z-87 plates. Another approach taken to describe the inclusions was to show the size distribution of a number of inclusions measured within a selected area of the polished and etched sample. These histograms of size distribution are shown in Figs 6.5 and 6.6. The histogram in Fig. 6.5 shows two or more peaks in the width measurements because some inclusions were discontinuous and they were measured separately. The only difference observed between the width in the Z-87 and G-69 histograms is that the inclusions are pinched off more frequently in the Z-87 samples.

The cracks were usually in stringer bands consisting of discontinuous inclusions. An inclusion was usually located near the fusion line where the crack was formed. The cracks that are associated with inclusions do not have any characteristic size or shape. The histograms of inclusion width and thickness measurements in samples G-69 and Z-87 also indicate that the geometric size or shape of the inclusions do not affect the crack frequency that is given in Table 6.3.

6.5 Discussion

The hot cracks referred to in this report are the small cracks radiating from the inclusions that have partially melted near the fusion line on the base metal side. In some instances isolated flaws were observed in the weld metal such as slag inclusions, porosity, cracking along fingers of the weld metal and a few relatively large cracks not associated with inclusions. These will be discussed later under the heading "metallographic observations of weld flaws."

a. Hot Crack Geometry

The hot cracks were associated with inclusions because they were found either radiating from an inclusion near the fusion line or they were in line with stringer laminations on the base metal side of the weld. Examples of both these conditions are shown in the photomicrographs of Figs. 6.7 and 6.8. By sectioning the welds in both the transverse and longitudinal directions the plane of the hot cracks was observed. The longitudinal section was along the long axis of the weld and parallel to the fusion line. The hot cracks were found to extend less than 0.025 mm from the fusion line into the base metal in most cases. Most hot cracks extended from 0.025 mm to 0.05 mm along the long axis of the weld. The plane of the fractured surface of the hot crack was parallel to the rolling direction.

b. Effect of Restraint of the Butt Weld on Hot Cracks

Unrestrained butt welds were made by welding procedure P80-11018-D on 1-1/2 in. thick HY-80 steel samples and no hot cracking was observed in metallographic sections of these welds. In an attempt to create additional shrinkage stresses in the butt welds 1-1/2 in. x 1 in. x 1 in. blocks were placed at the ends of the original 9 inch long butt weld double "V" groove in order to prevent transverse shrinkage. Few hot cracks were observed in this sample. A summary of the above results is listed in Table 6.3.

The butt welding during full restraint described in the experimental procedure section was successful in causing numerous hot cracks in the G-69 samples. Partial restraint of the butt weld, resulting from only fillet welding the HY-80 plates in a direction parallel to the long axis of the butt weld, also caused hot cracks. The amount of cracking per transverse sample surface examined can be found in Table 6.3.

c. Effect of Sulfur Concentration on Hot Cracking

In the above tests only the 1-1/2 in. thick G-69 plates of higher sulfur content (0.0155% S) were examined. The following tests were conducted on 3/4 in. thick plates butt welded by the same procedure. One G-69 plate was cut down from its 1-1/2 in. thickness to a 3/4 in. thick plate and welded to a rolled 3/4 in. thick Z-87 plate with a lower sulfur content (0.011% S). The unrestrained 3/4 in. plate listed in Table 6.3 was a 1-1/2 in. thick HY-80 steel plate cut down from plate G-67 by machining 3/4 in. from only one side. No restraint was used in welding the cut down G-67 plate and only a few hot cracks were observed in the numerous samples prepared (Table 6.3). The restrained, 3/4 in. thick sample in Table 6.3 was made from a 3/4 in. thick plate cut down from a 1-1/2 in. G-69 plate by machining off 3/8 in. of the rolled surface from both sides. This plate was welded to a rolled down 3/4 in. thick Z-87 plate. The striking result of the butt welded G-69 and Z-87 plate was that almost all the hot cracking was on the high sulfur side of the fully restrained 3/4 in. butt weld.

d. Length of Hot Cracks

Table 6.4 lists the average hot crack lengths observed in the transverse sections for all the welding conditions previously discussed for both the 1-1/2 in. and 3/4 in. thick samples. Most of these small hot cracks are about 0.025 mm long. Large cracks from other types of welding flaws are not included in the values given in Tables 6.3 and 6.4. The relatively consistent hot crack length can be related to the limited depth to which inclusions melt beyond the fusion line during the welding.

e. Metallographic Observations of Weld Metal Flaws

Large cracks, apparently not related to inclusions, were observed in rare instances and an example of this type of cracking is shown in Fig. 6.9.

Cracks were also observed to initiate from the periphery of slag inclusions, porosity (Fig. 6.10) and "fingers" of weld metal in the base metal (Fig. 6.11). These cracks were usually larger than the hot cracks and Table 6.5 lists the samples in which these defects were found along with their crack lengths.

f. Inclusion Study

A more exact description of the inclusions was desired because of the association of hot cracks with inclusions in the HY-80 steel microstructure. Sulfides were assumed present from the results of a sulfur print which was made. Methods of extraction for the inclusions resulted in extracted particles with an index of refraction between 1.35 and 1.63. This result was based on Becke lines observed around the edges of a large number of extracted stringers immersed in liquids of known indices of refraction. Sulfides must have an index of refraction of two or better. It was concluded that sulfide inclusions were not successfully extracted. X-ray diffraction patterns of the extracted particles matched the ASTM pattern for iron silicate. The sulfides were probably dissolved in the solvent used for extracting inclusions since they were not observed on the remaining sample or filtered from the solution.

g. Effect of "Buttering" on the Frequency of Hot Cracks

Two sections of the 1-1/2 in. thick G-69 plate were joined under full restraint by butt welding using welding procedure P80-11018-D. However, before one section was placed in the full restraint apparatus it was "battered" (coated with E11018 weld metal by weaving the electrode over one side of the 30° scarf.) The excess "battered" weld metal was machined off leaving a layer of weld metal approximately 1/8 in. thick. The 1-1/2 in. thick sections were then butt welded, sectioned and observed. The unbattered side of the weld had an average crack frequency and length similar to other 1-1/2 in. samples welded in full restraint. The only cracks observed on the "battered" side of

the butt weld were near the root of the weld where "battered" weld metal had not been placed. This clearly demonstrated that hot cracks can be decreased to a low level by "battering" the HY-80 steel before using regular welding procedures provided the remaining battered layer of weld metal is thick enough to prevent the melting of inclusions in the base metal.

A microhardness survey (Fig. 6.12) in a transverse section of the "battered" and normal G-69 plate shows the different Diamond Pyramid Hardness (DPH) in the Heat Affected Zone (HAZ) of the two plates and also in the remaining "battered" weld metal left after machining. The maximum hardness in the HAZ of the "battered" section was lower than maximum hardness in the unbattered HAZ of the HY-80 steel butt weld. A hardness survey of the HAZ of the battered scarf is shown in Fig. 6.13. This hardness survey shows the effect of the large heat input caused by the extensive weaving motion of the electrode during the battering operation.

h. Effect of Hot Cracks on Fatigue Life

A G-69 plate, 1-1/2 in. thick, was machined down to four 3/4 in. thick plates by removing 3/8 in. from both sides giving a thinner plate of higher sulfur content (0.0155% S). These plates were butt welded in full restraint to make two samples. The samples were then tested in a method similar to a regular 3/4 in. thick fatigue test sample. These samples were tested in 0 to +50.0 ksi tensile stress fatigue cycles. One sample reached a fatigue life of 170,000 cycles and the other 280,000 before an attachment weld at the end of each sample broke. The fully restrained welds containing hot cracks were not broken. The attachment weld was repaired for the sample that reached 280,000 cycles and the test was continued. The attachment weld broke twice before a total of 430,000 cycles was reached. The G-69 sample welded in restraint had not broken, even after 430,000 cycles of stress of 0 to +50.0 ksi.

The order of magnitude calculation given below illustrates the probable number of hot cracks contained in the 4 in. wide 3/4 in. thick fatigue sample used in the test just described. From measurements reported in Table 6.3 each transverse section of a cut down 3/4 in. G-69 sample welded in restraint should contain one (1) hot crack on the average. If it is assumed that each hot crack extended along the long axis of the weld for 20 mils. (0.020 in.) and no hot cracks overlapped along the long axis of the weld, then the number of hot cracks is equal to $4 \text{ in.} / 0.020 \text{ in.} = 200$ cracks in a 4 in. wide, 3/4 in. thick test sample. The 430,000 cycle fatigue life of the fully restrained weld sample approaches the fatigue life of the unwelded plate. Thus, the hot cracks along the fusion line do not appear to have an effect on zero-to-tension fatigue lives at this stress level.

Another 1-1/2 in. HY-80 steel sample was welded in restraint caused by two 15 in. long plain carbon steel bars 3 in. square that were fillet welded along the sides of the G-68 plate. The 1-1/2 in. thick plate was fillet welded as if it were a 3/4 in. thick plate. The restraining bars were removed after twenty-four hours and the entire plate was cut down to a 3/4 in. fatigue sample. This sample was fatigue tested at a stress level of ± 50.0 ksi. It failed after 13,000 cycles compared to a good weld fatigue life of about 60,000 cycles at the same stress level. The sample was sectioned and polished across the fatigue fracture region. Fig. 6.14 shows the fractured region after 13,000 cycles. The arrows indicate the cut of the transverse section shown in Fig. 6.15. The transverse section is near the center of the fatigue fracture. The entire crack is in the weld metal in this region. Hot cracking in the HAZ could not be responsible for the fatigue crack center. An investigation of this center of the fatigue crack and centers of fatigue cracks in the weld metal indicates that these centers are probably weld porosity.

In a region of the same transverse section shown in Fig. 6.15 only on the opposite side of the weld about 1/4 in. from the fracture, porosity was observed. This pore was located near the root pass of the weld and very close to the fusion line. This is a common location for small pores in the 3/4 in. and 1-1/2 in. thick HY-80 steel butt welded plates. This pore was too small to be observed in an x-ray radiograph of the plate even with reinforcement removed. Two small cracks were observed radiating out from each end of the pore as shown in the metallographic section in Fig. 6.16. The cracks were nearly parallel, within 4° , with one crack direction making an angle of 85° to the fatigue stress direction and with the other crack making an angle of 87.5° to the stress direction. Further proof that these were fatigue cracks rather than shrinkage cracks was the fact that at a high magnification the cracks were fine, close fitting rather than open, smooth shrinkage separations.

6.6 Conclusions

The following conclusions are based on results obtained from two commercial heats of HY-80 steel:

1. Restraint during the welding of HY-80 steel promotes hot cracks in the HAZ of HY-80 weldments. The hot cracks are on the average 0.025 mm in length for the two heats investigated.
2. Higher concentrations of sulfur in HY-80 appear to promote hot cracking. Hot cracks were observed for 0.0155% S, but practically no hot cracks were observed for 0.011% S HY-80 steel weldments. However, the size (width and thickness) of the inclusions does not appear to be related to the hot crack frequency from the measurements of inclusion size made in this investigation.

3. "Buttering" prevents hot cracking. "Buttering" also causes a slightly lower maximum hardness in the HAZ of the "battered" HY-80 steel compared to unbuttered HAZ.

4. Hundreds of hot cracks (micro-cracks) in the sample do not appear to reduce the fatigue life to any great extent for weldments tested in tension from 0 to +50.0 ksi for the 0.0155% S HY-80 steel welded in full restraint. The long axis of the weld was perpendicular to the axis of tension and the hot cracks propagated in the general direction of tension causing a small stress raiser factor.

5. In one case porosity was observed to be a nucleus for fatigue cracking in the weld metal of the HY-80 steel sample G-68 subjected to 13,000 cycles of a reversal stress level of -50.0 ksi to +50.0 ksi. Porosity in the weld metal was believed to be responsible for the early fatigue failure of the G-68 sample welded in restraint.

VII. SUMMARY

The following is a brief summary of the results of the various studies reported herein. A limited number of tests were conducted and many of the conclusions are based on a relatively small amount of data. Nevertheless, there are a number of observations that are considered to be very significant and are briefly summarized herein.

7.1 Fatigue Behavior of HY-100 Steel

Fatigue tests carried out on plain plate and butt welded specimens of HY-100 indicate:

1. The axial fatigue strength of the HY-100 steel plate was not greatly different from that of the HY-80 plate previously tested under a zero-to-tension stress cycle.

2. Under a zero-to-tension loading, transverse butt welded joints in HY-100 were found to have a lower fatigue resistance than comparable joints in HY-80. Furthermore, the HY-100 joints appeared to be more sensitive to the presence of internal flaws.

7.2 Weld Defect Study of HY-80 Steel

From the fatigue tests carried out on butt welds with intentional internal defects it may be concluded that:

1. For the range of intentional defects studied, the effect on the fatigue strength is independent of the type of defect and the amount of defective area.

2. At 100,000 cycles the fatigue strength of the members with intentional flaws is about the same as that of the as-welded joints with the reinforcement in place (no intentional defects).

3. At shorter lives (less than 100,000 cycles), it appears that the intentional internal weld defects in specimens with weld reinforcement removed are more important than the external geometry of some as-welded joints, while the external weld geometry appears to be more important at the longer lives.

7.3 Crack Growth Study

Radiographic techniques were employed to determine the number of cycles to crack initiation and subsequent propagation of fatigue cracks in butt welded joints of HY-80 steel. Because of the lack of sensitivity and difficulty of interpretation of the radiographs, there is some uncertainty as to the time of initiation. Nevertheless, a number of conclusions can be drawn on the basis of the test results:

1. For a given stress cycle there appeared to be no consistent number of cycles for the initiation of a macroscopic fatigue crack; rather, the initiation appears to be a function of the type and geometry of the internal weld defects, the location of the defect with respect to the cross section of the weld, and the residual stresses.

2. Upon initiation of a fatigue crack, the duration of propagation was found to fall within a relatively narrow range of cycles for a given level of applied stress.

3. On the basis of the crack detection procedure used in these tests, the number of cycles necessary to propagate the fatigue crack to the specimen surface was found to be less than 50 percent of the total life.

7.4 Metallurgical Studies

A number of metallurgical studies have been conducted to evaluate the effects of inclusions and welding restraint upon the quality of weld metal

In butt welds of HY-80 steel. The results of these studies may be summarized as follows:

1. The restraint during welding of HY-80 steel produced hot cracks in the heat affected zone of the weldment.

The degree of hot cracking appeared to increase with an increase in the sulphur concentration of the steel.

2. "Buttering" of the beveled plates helped to prevent hot cracking in the heat affected zone.

3. The hot cracks (microcracks) in the weldments did not appear to reduce the fatigue life of the members to any great extent.

7.5 General Summary and Conclusions

On the basis of the results of the various tests reported herein several general observations may be made concerning the behavior of HY-80 and HY-100 steels and welded joints in these steels. These conclusions are as follows:

1. Based on the average values of fatigue strength at 100,000 cycles shown in the following tabulation, plain plate members of HY-80 and HY-100 are found to have fatigue strengths considerably above that of mild structural steel. However, the increase in fatigue strength for the butt welded joint in HY-100 is much smaller than that for the HY-80 steel.

Steel	F _{100,000} , Ksi (Zero-to-tension)	
	Plain Plate	Transverse Butt Weld*
Mild structural steel (ASTM-A7)	48.0	32.3
HY-80	65.6	57.1
HY-100	68.6	41.4

* As-welded, reinforcement on

The as-welded joint efficiencies under axial loading are seen to range between 60 and 87 percent for the HY-100 and HY-80 materials respectively.

2. Radiographic evaluations in HY-80 demonstrate that the test joints were within Navy specifications limits for porosity and slag. However, when the weld reinforcement was removed from members having flaws within the specification limits, their fatigue strength at 100,000 cycles was no better than that of sound as-welded butt joints with the reinforcement in place.

3. Preliminary results of ultrasonic measurements for crack propagation and detection in HY-80 suggest that this detection method, if it can be fully developed, may provide earlier crack detection than radiographic examination. However, this can only be realized through extensive developments in the operational techniques.

4. The microcracks observed in the butt welded joints of HY-80 had less effect on the fatigue resistance of the members than the porosity and slag inclusions permitted by present inspection specifications.

BIBLIOGRAPHY

1. Sahgal, R. K. and Munse, W. H., "Fatigue Behavior of Axially Loaded Weldments in HY-80 Steel," University of Illinois, Department of Civil Engineering, Structural Research Series 204, September 1960.
2. Hartmann, A. J. and Munse, W. H., "Fatigue Behavior of Welded Joints and Weldments in HY-80 Steel Subjected to Axial Loadings," University of Illinois, Department of Civil Engineering, Structural Research Series 250, July 1962.
3. Zimmerman, J. E., Jr., and Munse, W. H., "Fatigue Behavior of Defective Welded Joints in HY-80 Steel Subjected to Axial Loading," University of Illinois, Department of Civil Engineering, Structural Research Series 252, July 1962.
4. Hartmann, A. J., Bruckner, W. H., Mooney, J. and Munse, W. H., "Effect of Weld Flaws on the Fatigue Behavior of Butt-Welded Joints in HY-80 Steel," University of Illinois, Department of Civil Engineering, Structural Research Series 275, December 1963.
5. Bureau of Ships, U. S. Navy, "Fabrication, Welding and Inspection of HY-80 Submarine Hulls," NAVSHIPS 250-637-3, January 1962.
6. Liu, H. W., "Crack Propagation in Thin Metal Sheet Under Repeated Loading," University of Illinois, Department of Theoretical and Applied Mechanics, Report No. 155, December 1959.
7. Lipsitt, H. A., Forbes, F. W. and Baird, R. B., "Crack Propagation in Cold Rolled Aluminum Sheet," Proceedings, American Society for Testing and Materials, 1959.

TABLE 2.1

PHYSICAL PROPERTIES OF BASE METAL
(Data Supplied by Manufacturer)

Heat Number	Designation	Thickness (inches)	Properties in the Longitudinal Direction				
			Yield Strength* (ksi)	Tensile Strength (ksi)	Elong. in 2 inches (percent)	Reduction in Area (percent)	Charpy V-Notch ft-lbs. @ -120°F
69S344	G	1-1/2	88.5	108.3	22.6	69.2	92
N31543	Z	3/4	90.0	109.2	25.3	70.4	136
N15423	HY	3/4	110.0	127.5	23.0	71.1	83

* 0.2 percent offset

TABLE 2.2
CHEMICAL COMPOSITION OF BASE METAL
(From Mill Report)

Chemical Content (percent)	Heat Number		
	69S344	N31543	N15423
C	0.16	0.17	0.20
Mn	0.33	0.28	0.30
P	0.021	0.010	0.010
S	0.019	0.009	0.014
Si	0.26	0.27	0.21
Ni	2.86	2.29	3.00
Cr	1.61	1.31	1.67
Mo	0.48	0.32	0.50
Cu	----	0.06	0.11

TABLE 3.1
RESULTS OF FATIGUE TESTS OF HY-100 PLAIN PLATE SPECIMENS
(Zero-to-Tension)

Specimen Number	Stress Cycle (ksi)	Life (cycles)	Location of Fracture**	Computed Fatigue Strength, ksi*				
				F 50,000	F 100,000	F 200,000	F 500,000	F 500,000
HY-4	0 to +80.0	46,400	a	78.3	63.5	51.7	---	---
HY-6	0 to +80.0	57,100	f	83.1	67.6	54.8	---	---
HY-7	0 to +76.5	81,200	f	88.4	71.7	58.4	---	---
HY-3	0 to +50.0	180,100	f	73.5	59.7	48.4	36.8	---
HY-2	0 to +50.0	253,100	a	81.1	66.1	53.6	40.7	---
HY-5	0 to +50.0	546,300	a	102.5	83.2	67.5	51.3	---
Average				84.5	68.6	55.7	42.9	---

* k = 0.301

** a: failure initiated at radius of test section

f: failure initiated at mill scale surface near radius of test section

TABLE 3.2
 RESULTS OF FATIGUE TESTS OF HY-100 TRANSVERSE BUTT WELDS IN
 THE AS-WELDED CONDITION
 (Zero-to-Tension)

Specimen Number	Stress Cycle (ksi)	Life (cycles)	Location of Fracture***	Computed Fatigue Strength, ksi*			
				F _{20,000}	F _{50,000}	F _{100,000}	F _{200,000}
HY-9	0 to +80.0	4,700	b	(45.1)**	---	---	---
HY-8	0 to +80.0	5,400	b	(47.7)**	---	---	---
HY-10	0 to +80.0	8,200	b	(56.3)**	---	---	---
HY-13	0 to +50.0	24,100	b	(53.8)**	---	---	---
HY-11	0 to +50.0	61,500	c	77.7	54.3	41.3	31.4
HY-12	0 to +50.0	61,800	c	77.9	54.4	41.4	31.5
HY-14	0 to +30.0	212,500	c	---	53.1	40.4	30.8
HY-15	0 to +30.0	240,600	c	---	55.2	42.4	32.2
			Average	77.8	54.2	41.4	31.5

* k = 0.394

** not included in average; fatigue strengths were calculated only for sound welds

*** b: failure initiated in weld metal

c: failure initiated at edge of weld reinforcement

TABLE 3.3
SUMMARY OF FATIGUE TESTS OF HY-80 AND HY-100 MATERIAL
(Zero-to-Tension)

Specimen Type	Surface Condition	k	Computed Fatigue Strength, ksi				
			F _{20,000}	F _{50,000}	F _{100,000}	F _{200,000}	F _{2,000,000}
a) 3/4 In. Thick HY-80 Material (1)							
Plain Plate	As-Rolled	0.201	91.0	75.6	65.6	57.1	35.8
Transverse Butt Weld	As-Welded	0.279	---	69.3	57.1	45.0	23.8
Transverse Butt Weld	Reinforcement Removed	0.229	---	80.7	69.0	58.9	34.8
b) 3/4 In. Thick HY-100 Material (2)							
Plain Plate	As-Rolled	0.301	---	84.5	68.6	55.7	---
Transverse Butt Weld	As-Welded	0.394	77.8	54.2	41.4	31.5	---
c) 1-1/2 In. Thick HY-80 Material (3)							
Plain Plate	As-Rolled	0.149	89.9	78.5	67.9	60.9	43.6
Transverse Butt Weld	As-Welded	0.340	77.3	56.3	44.6	35.0	---
Transverse Butt Weld	Reinforcement Removed	0.146	82.0	71.2	64.3	58.2	---

(1) results reported in Ref. 4

(2) results of this study

(3) results reported in Ref. 2

TABLE 4.1
 RESULTS OF FATIGUE TESTS OF TRANSVERSE BUTT WELDS IN
 1-1/2 IN. HY-80 STEEL
 (Intentional Porosity in Weld)

Specimen Number	Stress Cycle (ksi)	Life (cycles)	Location of Fracture	Computed Fatigue Strength, * ksi		
				F 20,000	F 50,000	F 100,000
G-82	0 to +70.0	6,300	b	55.2	45.7	39.8
G-89	0 to +70.0	6,700	b	55.9	46.4	40.2
G-84	0 to +70.0	7,100	b	56.6	46.9	40.6
G-85	0 to +70.0	7,900	b	57.8	47.9	41.5
G-83	0 to +70.0	10,900	b	61.8	51.2	44.4
G-81	0 to +50.0	22,800	b	51.3	42.7	36.9
G-87	0 to +50.0	39,300	b	57.5	47.6	41.4
G-86	0 to +50.0	53,600	b	61.0	50.7	44.0
G-88	0 to +50.0	56,000	b	61.8	51.2	44.4
Average				57.7	47.8	41.5

* k = 0.210

*** b: failure initiated in weld metal

TABLE 4.2

RESULTS OF DEFECT EXAMINATION OF TRANSVERSE BUTT WELDS IN
 1-1/2 IN. HY-80 STEEL
 (Intentional Porosity in Weld)

Specimen Number	Stress Cycle (ksi)	d _e ^{**} (in)	Defective Area, Percent		Radiographic Rating*	Description of Defect
			Based on Radiograph	Based on Fracture Surface		
G-82	0 to +70.0	0.035	0.027	0.060	P	one cluster
G-89	0 to +70.0	0.051	0.248	0.115	P	one cluster
G-84	0 to +70.0	0.053	0.045	0.285	P	one cluster
G-85	0 to +70.0	0.065	0.050	0.250	P	one cluster
G-83	0 to +70.0	0.039	0.219	0.058	P	one cluster
G-81	0 to +50.0	0.046	0.088	0.129	P	two clusters; offset in the direction of stress
G-87	0 to +50.0	0.067	0.219	0.334	F	one cluster
G-86	0 to +50.0	0.064	0.180	0.184	P	one cluster
G-88	0 to +50.0	0.046	0.158	0.282	F	two clusters; offset in the direction of stress

* based on radiographic requirements of Navy Specifications (5)

** effective diameter of largest pore in porosity clusters

TABLE 4-3
 RESULTS OF FATIGUE TESTS OF TRANSVERSE BUTT WELDS IN
 1-1/2 IN. HY-80 STEEL
 (Intentional Slag Inclusions in Weld)

Specimen Number	Stress Cycles (ksi)	Life (cycles)	Location of Fracture **	Computed Fatigue Strength, * ksi		
				F _{20,000}	F _{50,000}	F _{100,000}
G-102	0 to +70.0	6,700	b	55.6	45.9	39.7
G-95	0 to +70.0	8,800	b	58.9	48.5	42.0
G-96	0 to +70.0	10,900	b	61.7	50.8	44.0
G-98	0 to +70.0	11,300	b	62.1	51.2	44.2
G-93	0 to +50.0	26,400	b	52.9	43.7	37.8
G-103	0 to +50.0	28,700	b	53.9	44.5	38.5
G-92	0 to +50.0	42,800	b	58.7	48.4	41.8
G-91	0 to +50.0	58,500	b	62.7	51.8	44.7
G-90	0 to +50.0	98,800	b	<u>69.9</u>	<u>57.8</u>	<u>49.8</u>
			Average	59.6	49.2	42.5

* k = 0.210

** b: failure initiated in weld metal

TABLE 4.4
 RESULTS OF DEFECT EXAMINATION OF TRANSVERSE BUTT WELDS IN
 1-1/2 IN. HY-80 STEEL
 (Intentional Slag Inclusions in Weld)

Specimen Number	Stress Cycle (ksi)	Defective Area, Percent		Radiographic Rating*	Description of Defect
		Based on Radiographs	Based on Fracture Surface		
G-102	0 to +70.0	1.49	1.00	F	2 defects
G-95	0 to +70.0	0.022	0.025	P	
G-96	0 to +70.0	0.340	0.394	F	2 defects
G-98	0 to +70.0	0.349	0.040	P	
G-93	0 to +50.0	-----	0.163	P	defect not visible on X-ray
G-103	0 to +50.0	0.688	0.027	F	
G-92	0 to +50.0	0.271	0.054	P	
G-91	0 to +50.0	0.258	0.076	F	2 defects
G-90	0 to +50.0	0.041	0.055	P	porosity + slag

* based on radiographic requirements of Navy Specifications (5)

TABLE 4.5
RESULTS OF FATIGUE TESTS AND DEFECT EXAMINATION OF TRANSVERSE BUTT WELDS IN
3/4 IN. HY-80 STEEL
(Intentional Porosity and Slag)

Specimen Number	Stress Cycle	Life (cycles)	Computed F _{50,000} ** (ksi)	Defective Area, Percent		Radiographic Rating	Type of Defect
				Based on Radiograph	Based on Fracture Surface		
Z-94	±50.0	14,800	±37.3	0.72	0.61	F	slag
Z-96	±50.0	14,300	±37.0	0.40	0.12	F	slag
Z-56*	±50.0	14,200	±37.0	0.025	0.11	P	porosity
Z-74*	±50.0	13,400	±36.5	0.14	0.19	P	slag
Z-95	±50.0	8,900	±33.0	0.047	0	P	slag
Z-99	±50.0	5,800	±29.9	0.75	0.39	F	porosity + slag
Z-97	±50.0	5,300	±29.1	0.37	0.20	F	porosity
Z-77*(1)	±47.4	4,600	±26.8	0.64	0.71	F	slag
Z-57*	±30.0	145,900	±38.8	0.046	0.18	P	porosity
Z-78*	±30.0	90,100	±34.5	crack	0.14	F	slag
Z-75*	±30.0	78,800	±33.5	crack	0.13	F	slag

* data from Ref. 4

** assuming K = 0.24

(1) subjected to bending

TABLE 5.1

RESULTS OF FATIGUE CRACK INITIATION AND PROPAGATION STUDY OF
TRANSVERSE BUTT WELDS IN 3/4 IN. HY-80 STEEL
CONTAINING INTENTIONAL WELD DEFECTS

(1)	(2)	(3)	(4)	(5)	(6)	(7)	(8)
Specimen Number	Stress Cycle (ksi)	Cycles to Start of Crack Growth (a) (cycles)	Test Life (b) (cycles)	Life to "Failure" (c) (cycles)	Ratio Col. 3 / Col. 4	Initial Defect Length Measured on Fracture Surface (inches)	Type of Defect
Z-94	±50.0	9,000	10,800	14,800	.833	.18	slag
Z-95	±50.0	4,800	6,900	8,900	.696	.05	slag
Z-96	±50.0	8,600	13,100	14,300	.656	.04	slag
Z-97	±50.0	2,800	3,800	5,300	.737	.27	porosity
Z-99	±50.0	1,400	5,300	5,800	.264	.05	porosity
Z-98	0 to +50.0	106,000	120,000	130,500	.883	.07	porosity
Z-100	0 to +50.0	2,500	5,200	17,300	.481	2 - .05 ea. (.45) (d)	drilled holes (lack of fusion)
Z-101	0 to +50.0	90,000	99,400	104,400	.905	2 - .05 ea.	drilled holes
Z-102	0 to +50.0	82,100	89,000	111,500	.922	11 - .05 ea.	drilled holes
Z-70 (e)	0 to +50.0	43,700	52,300	55,600	.836	.14	slag
Z-79 (e)	0 to +50.0	17,000	26,300	32,900	.646	.16	slag
Z-80 (e)	0 to +50.0	11,400	24,700	27,200	.462	.31	slag

(a) estimated as 1/2 no. cycles between last x-ray showing no fatigue crack and first x-ray showing crack

(b) estimated as 1/2 no. cycles between last observation showing no crack on specimen surface and first observation showing surface crack

(c) defined in Chapter I (usually less than complete fracture)

(d) fatigue crack initiated at lack of fusion, not at drilled holes

(e) data from earlier report (4)

TABLE 6.1
MANGANESE, SULFUR, AND PHOSPHORUS CONTENT OF
THE HY-80 STEEL PLATES
(in Percent)

Sample	Sample Position*	Manganese	Phosphorus	Sulfur
G-69	1	0.28	0.014	0.016
	1	0.29	0.012	0.015
	2	0.30	0.012	0.016
	2	0.28	0.010	0.016
	Average	0.288	0.012	0.0155
Z-87	1	0.26	0.008	0.011
	1	0.28	0.008	0.010
	2	0.30	0.008	0.013
	2	0.28	0.008	0.010
	Average	0.28	0.008	0.011

* Position (1) was near the surface and position (2) was at the mid-thickness of the plate.

TABLE 6.2
 AVERAGE SIZE OF SULFIDE INCLUSIONS PER
 NUMBER MEASURED
 (microns)

Sample	Plate Thickness	Average Inclusion Width*	Average Inclusion Thickness*
G-69	1-1/2 in.	32/21	2.59/21
Z-87	3/4 in.	110/25	1.5 /25

* section cut perpendicular to the rolling direction and across the thickness of the plate

TABLE 6.3
 NUMBER OF HOT CRACKS PER TRANSVERSE SECTION
 OF HY-80 STEEL EXAMINED

Sample Number	Test Plate	Type of Restraint	Thickness of Steel Plate			
			1-1/2 in.	1-1/4 in.	1 in.	3/4 in.
1	G-67	weak transverse	2/7	0/12	0/5	0/5
2	G-67	none	0/6	0/2		2/9
3	G-69	both transverse and longitudinal	21/6			
4	G-69	longitudinal restraint relaxed	14/3			
5	G-69 Z-87	both transverse and longitudinal				6/7

TABLE 6.4
AVERAGE LENGTHS OF HOT CRACKS
(Millimeters)

Sample *	Thickness of HY-80 Steel Plate	
	1-1/2 in.	3/4 in.
1	0.02	
2		0.02
3	0.03	
4	0.02	0.04

* same samples as shown in Table 6.3

TABLE 6.5
LENGTHS OF HOT CRACKS NOT ASSOCIATED WITH INCLUSIONS
(Millimeters)

Sample *	Thickness of HY-80 Steel Plate	
	1-1/2 in.	3/4 in.
3A13		
crack a	0.08	
crack b	0.11	
3A1	0.20	
4D5		0.26
2D10		0.50

* All samples were from the 1-1/2 in. thick G-69 test plate. The 1-1/2 in. thick samples were cut down on one side in 2D10 and on both sides 4D5.

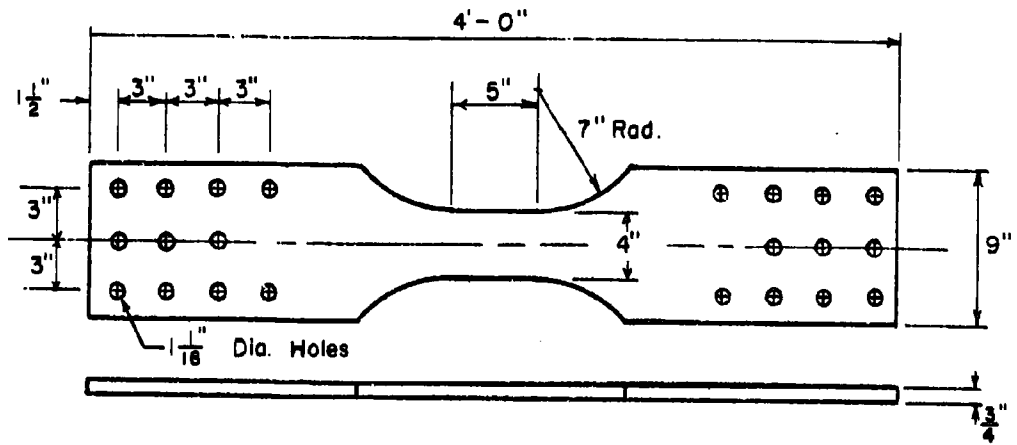

(a) Plain Plate

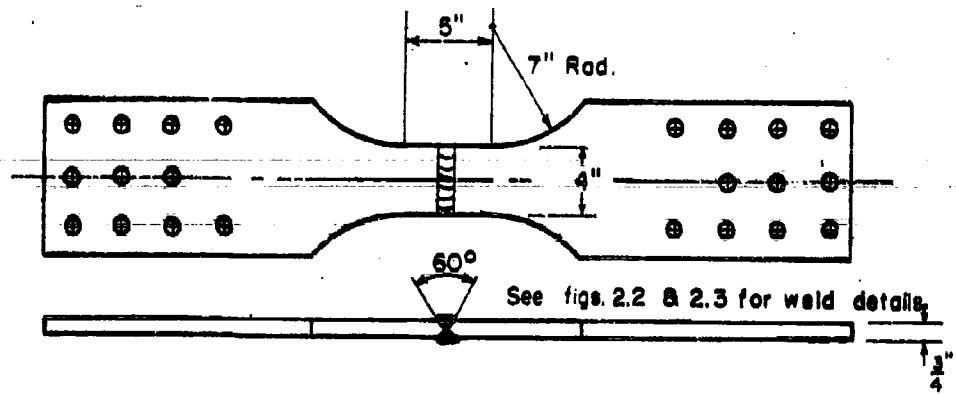

(b) Transverse Butt Weld

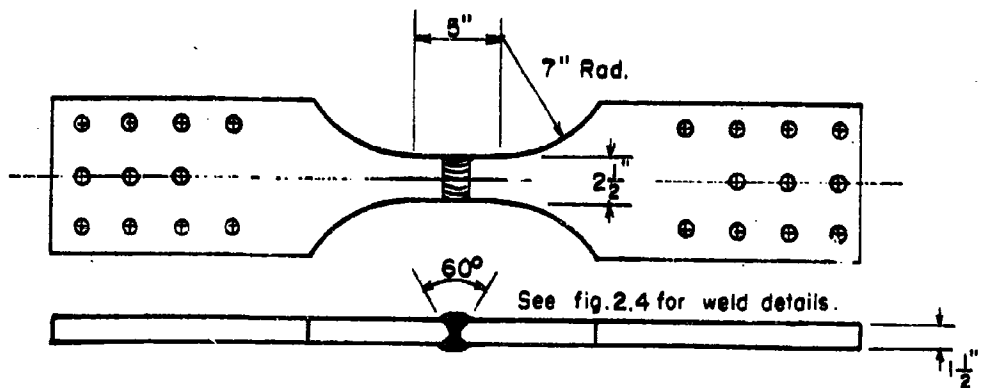

(c) Transverse Butt Weld

FIG. 2.1 DETAILS OF TEST SPECIMENS.

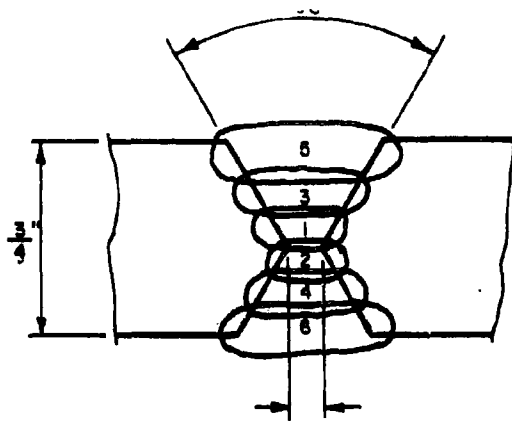

Root opening $\frac{1}{8}$ in.

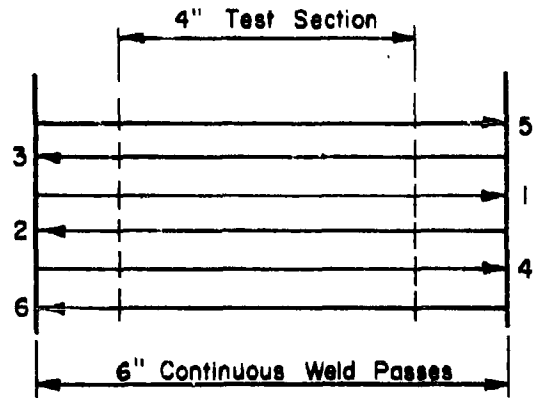

Arrows indicate direction of welding.

Surface of plate adjacent to weld cleaned by grinding before welding.

Pass	Electrode size, in.	Current, amps.	Rate of travel, in./min.
1	$\frac{5}{32}$	130	5
2	$\frac{5}{32}$	140	5
3	$\frac{3}{16}$	230	8
4	$\frac{3}{16}$	220	7
5	$\frac{3}{16}$	210	7
6	$\frac{3}{16}$	210	7

Voltage: 21 Volts

Polarity: D.C. Reversed

Preheat: 150° F

Electrode: MIL 11018

Interpass Temperature: 200° F (Maximum)

Heat Input: 40,000 Joules/in. (Maximum)

All welding in flat position

Underside of pass 1 ground before placing pass 2

FIG. 2.2 WELDING PROCEDURE P80-11018-A
(Transverse Butt Welds in HY-80)

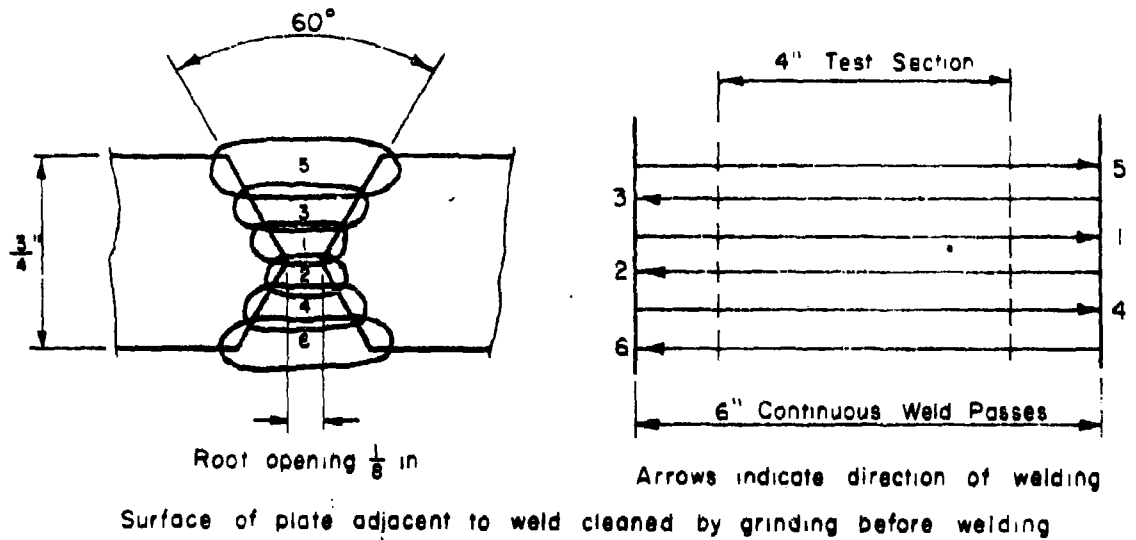

Pass	Electrode size, in	Current, amps	Rate of travel, in./min
1	$\frac{5}{32}$	130	5
2	$\frac{5}{32}$	140	5
3	$\frac{3}{16}$	230	8
4	$\frac{3}{16}$	220	7
5	$\frac{3}{16}$	210	7
6	$\frac{3}{16}$	210	7

Voltage . 21 Volts

Polarity . D.C. Reversed

Preheat 150° F

Electrode MIL 11018

Interpass Temperature 200° F (Maximum)

Heat Input 40,000 Joules/in (Maximum)

All welding in flat position

Underside of pass 1 ground before placing pass 2

FIG.2.3 WELDING PROCEDURE P100-11018-J
(Transverse Butt Welds in HY-100)

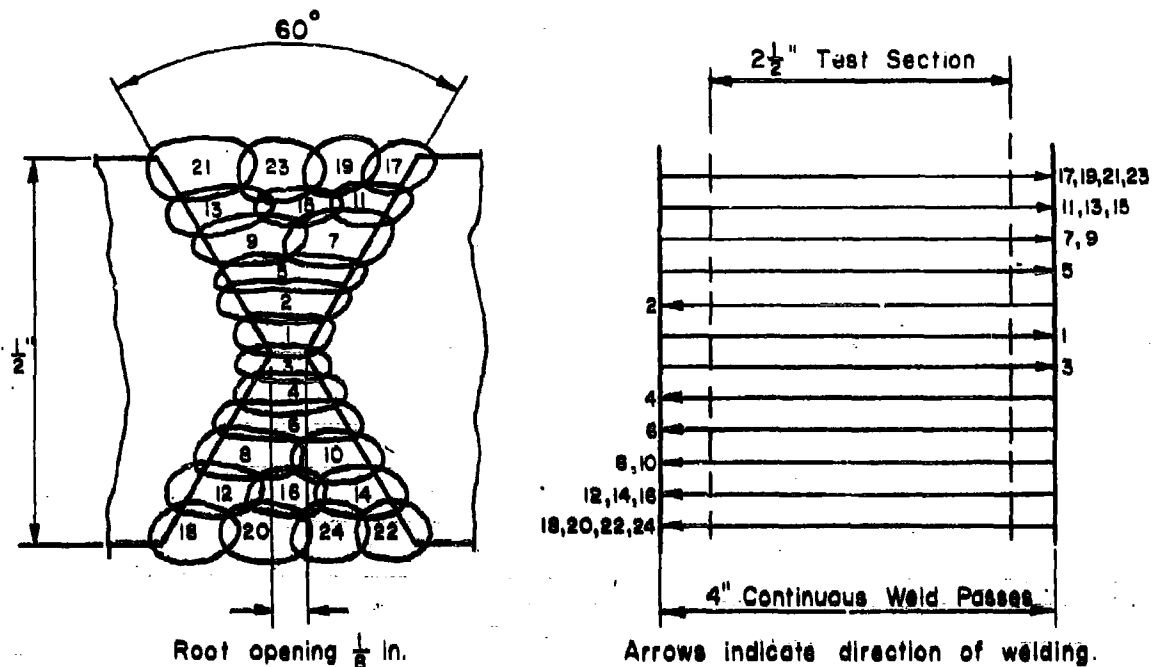

Surface of plate adjacent to weld cleaned by grinding before welding.

Pass	Electrode size, in.	Current, amps.	Rate of travel, in./min.
1	$\frac{5}{32}$	140	4
2	$\frac{3}{16}$	230	6
3	$\frac{5}{32}$	160	4
4-16	$\frac{3}{16}$	230	6
17-24	$\frac{3}{16}$	200	5

Voltage: 21 Volts

Polarity: D.C. Reversed

Preheat: 200° F

Electrode: MIL 11018

Interpass Temperature: 200° F (Maximum)

Heat Input: 50,000 Joules/in. (Maximum)

All welding in flat position.

Underside of pass 1 back-gouged with air arc before pass 3.

**FIG.2.4 WELDING PROCEDURE P80-11018-D
(Transverse Butt Welds in HY-80)**

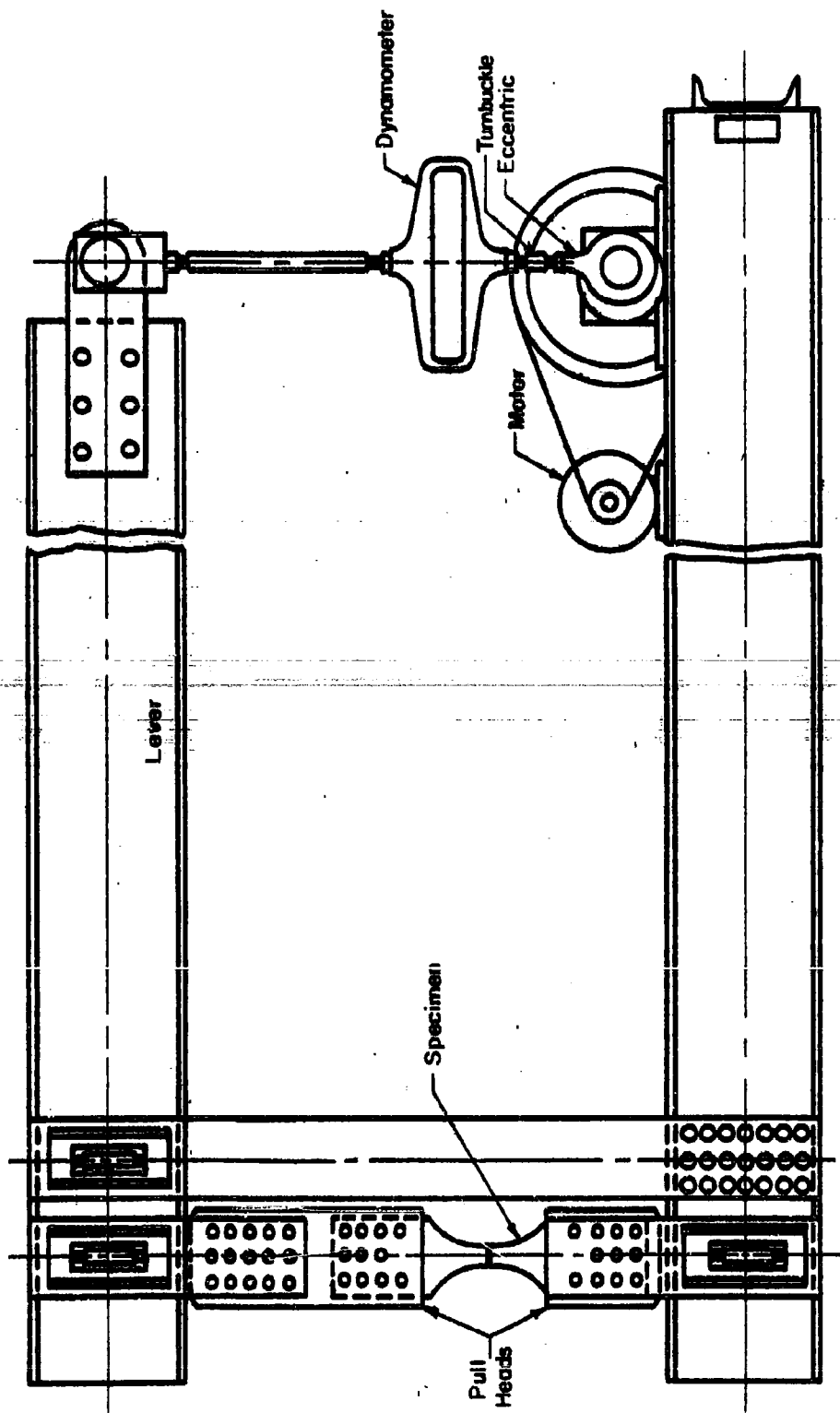
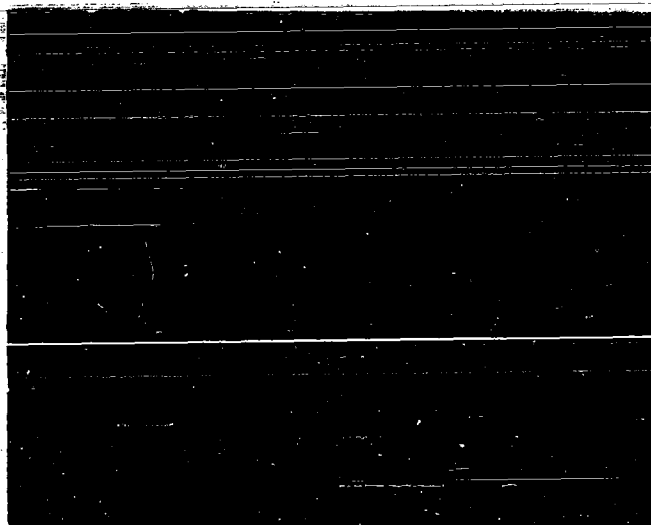

FIG.2.5 ILLINOIS' FATIGUE TESTING MACHINE AS USED FOR AXIAL LOADING OF WELDED JOINTS



a) BASE METAL. (230X MAGNIFICATION)



b) HEAT AFFECTED ZONE. (230X MAGNIFICATION)

FIG.3.1 TYPICAL PHOTOMICROGRAPHS OF TRANSVERSE BUTT WELD IN 3/4 IN. HY-80 MATERIAL.

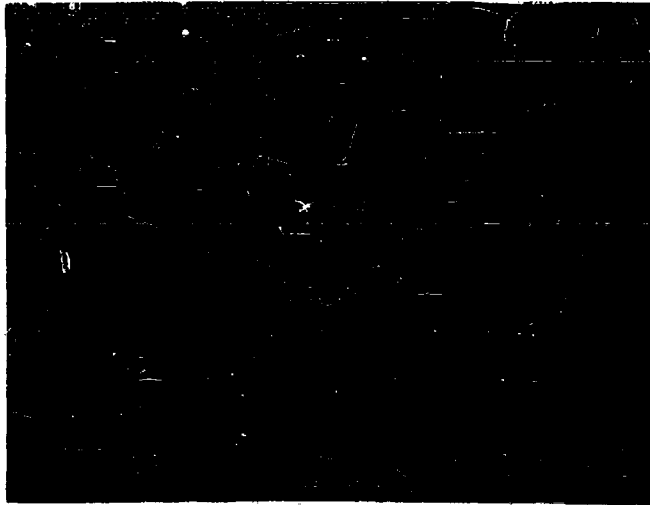

a) BASE METAL. (230X MAGNIFICATION)

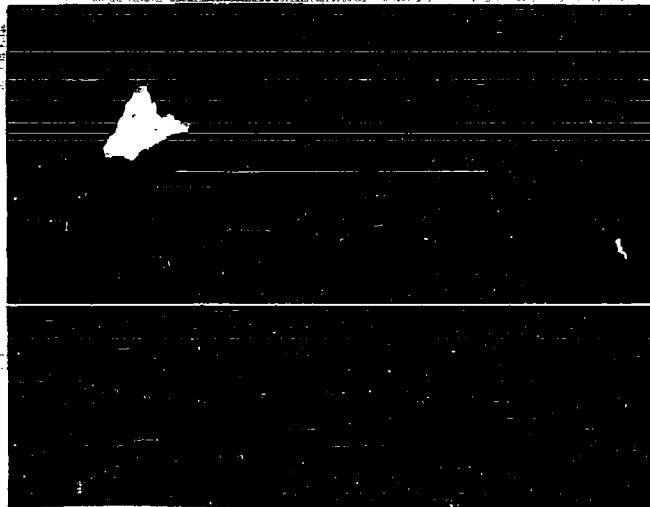

b) HEAT AFFECTED ZONE. (230X MAGNIFICATION)

FIG.3.2 TYPICAL PHOTOMICROGRAPHS OF TRANSVERSE BUTT WELD IN 3/4 IN. HY-100 MATERIAL.

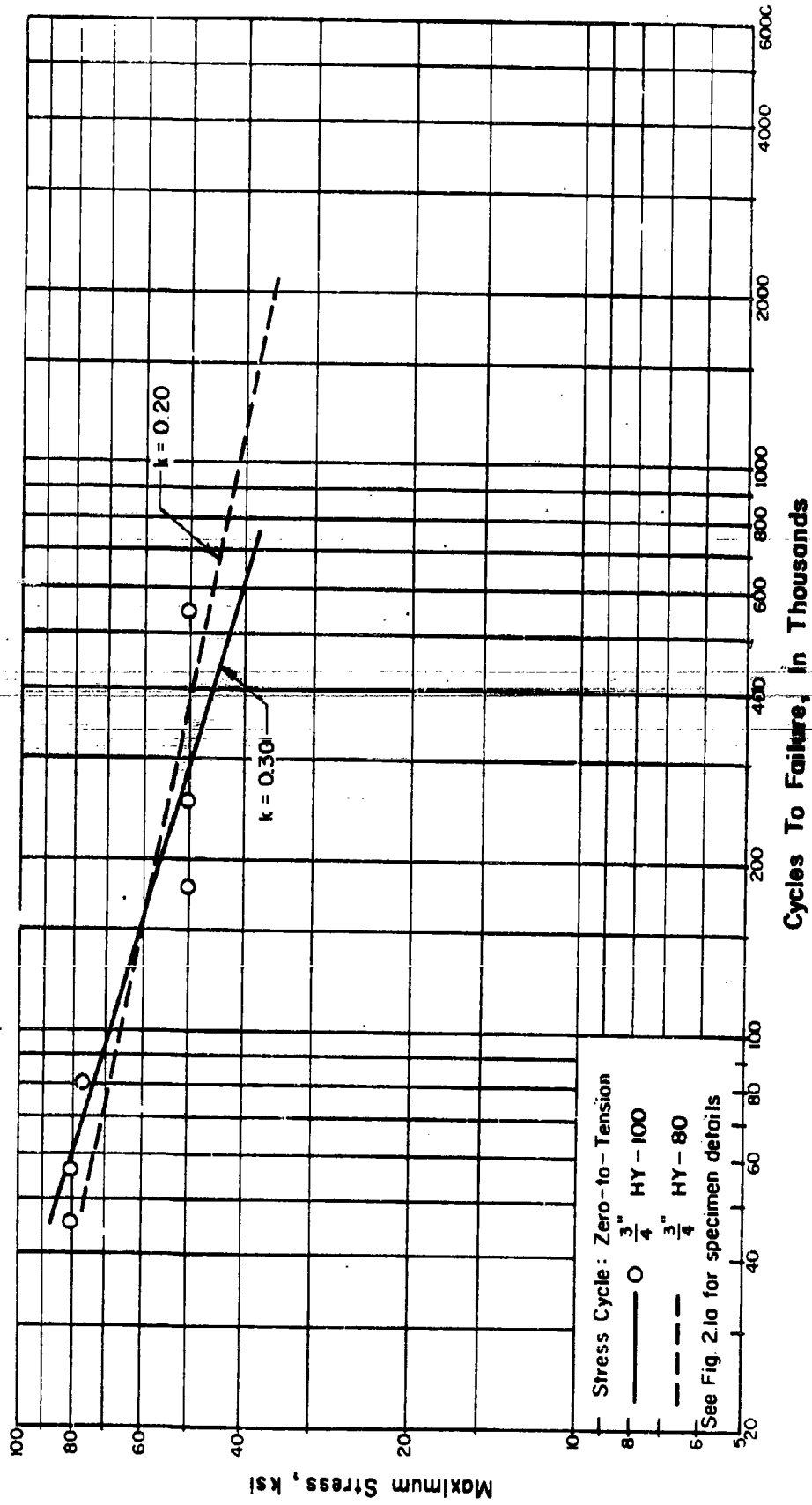
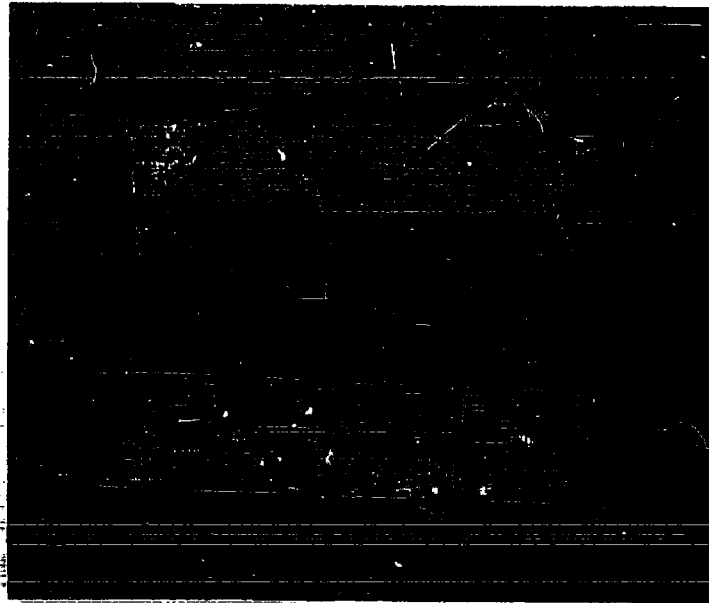

FIG. 3.3 RESULTS OF FATIGUE TESTS OF AS-ROLLED HY-100 PLAIN PLATE SPECIMENS.



NOTE: FRACTURE DID NOT START AT CORNER.

**FIG.3.4 FRACTURE SURFACE OF AS-ROLLED HY-100
PLAIN PLATE SPECIMEN.**

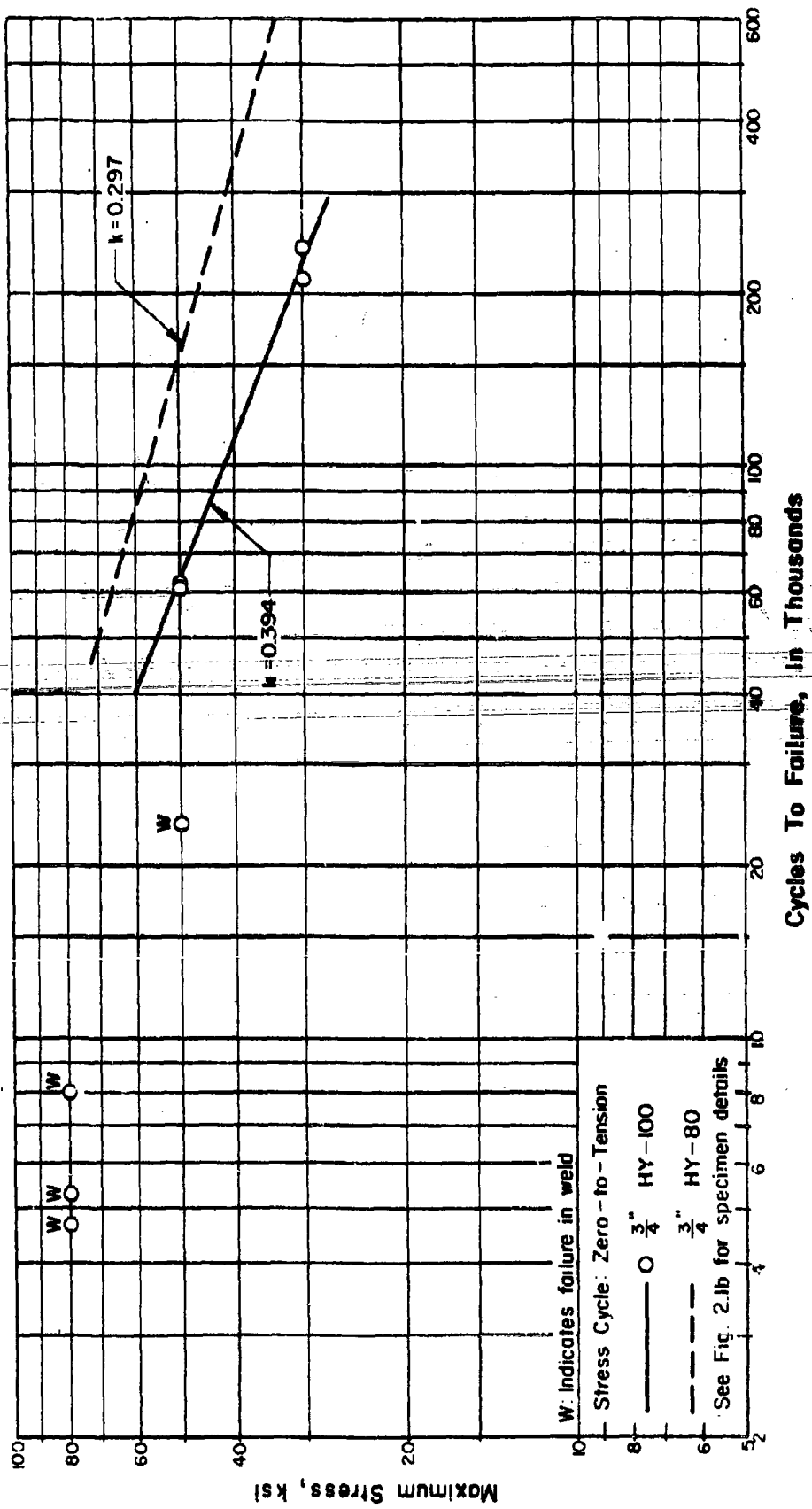
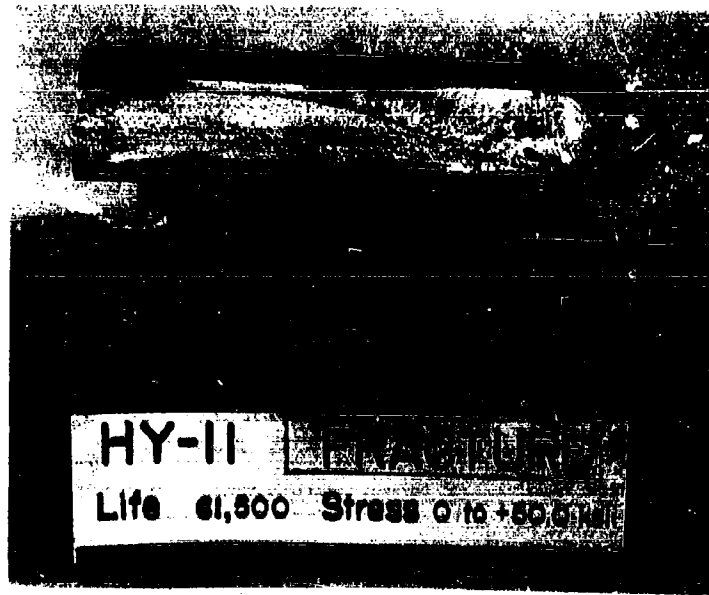
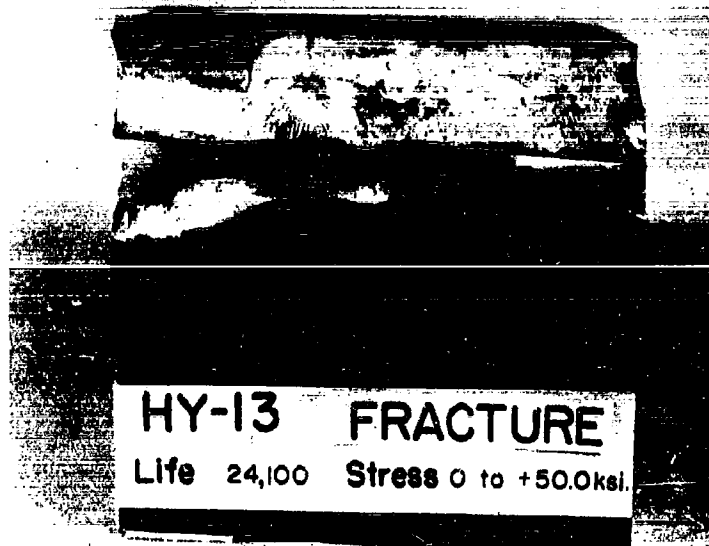

FIG. 3.5 RESULTS OF FATIGUE TESTS OF HY-100 TRANSVERSE BUTT WELDS IN THE AS-WELDED CONDITION.



a) FAILURE INITIATED AT EDGE OF WELD REINFORCEMENT.



b) FAILURE INITIATED IN WELD.

FIG.3.6 TYPICAL FRACTURES OF TRANSVERSE BUTT WELDS IN 3/4 IN. HY-100 MATERIAL.

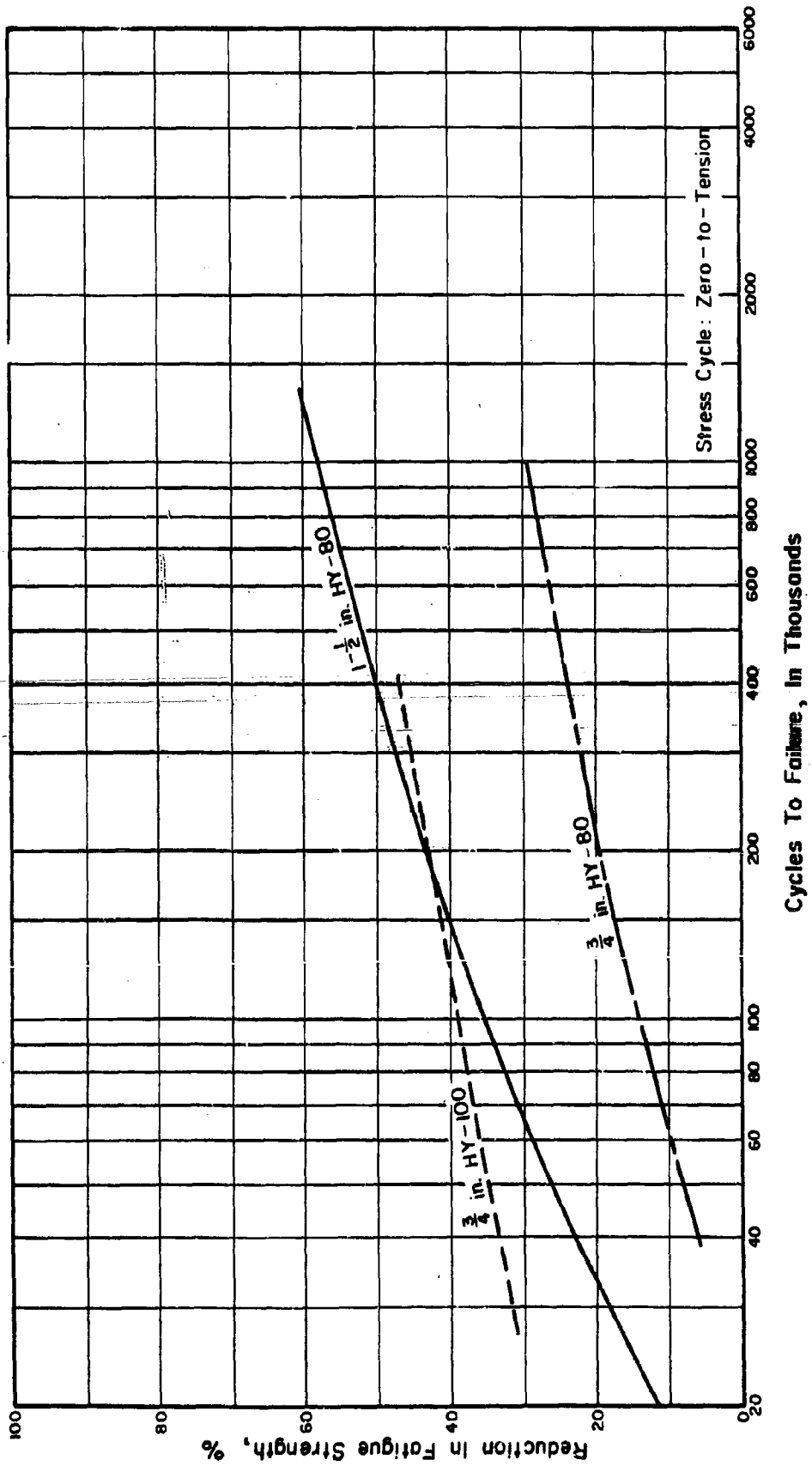

FIG. 3.7 REDUCTION IN FATIGUE STRENGTH FROM AS-ROLLED PLAIN PLATES DUE TO A TRANSVERSE BUTT WELD IN THE AS-WELDED CONDITION.

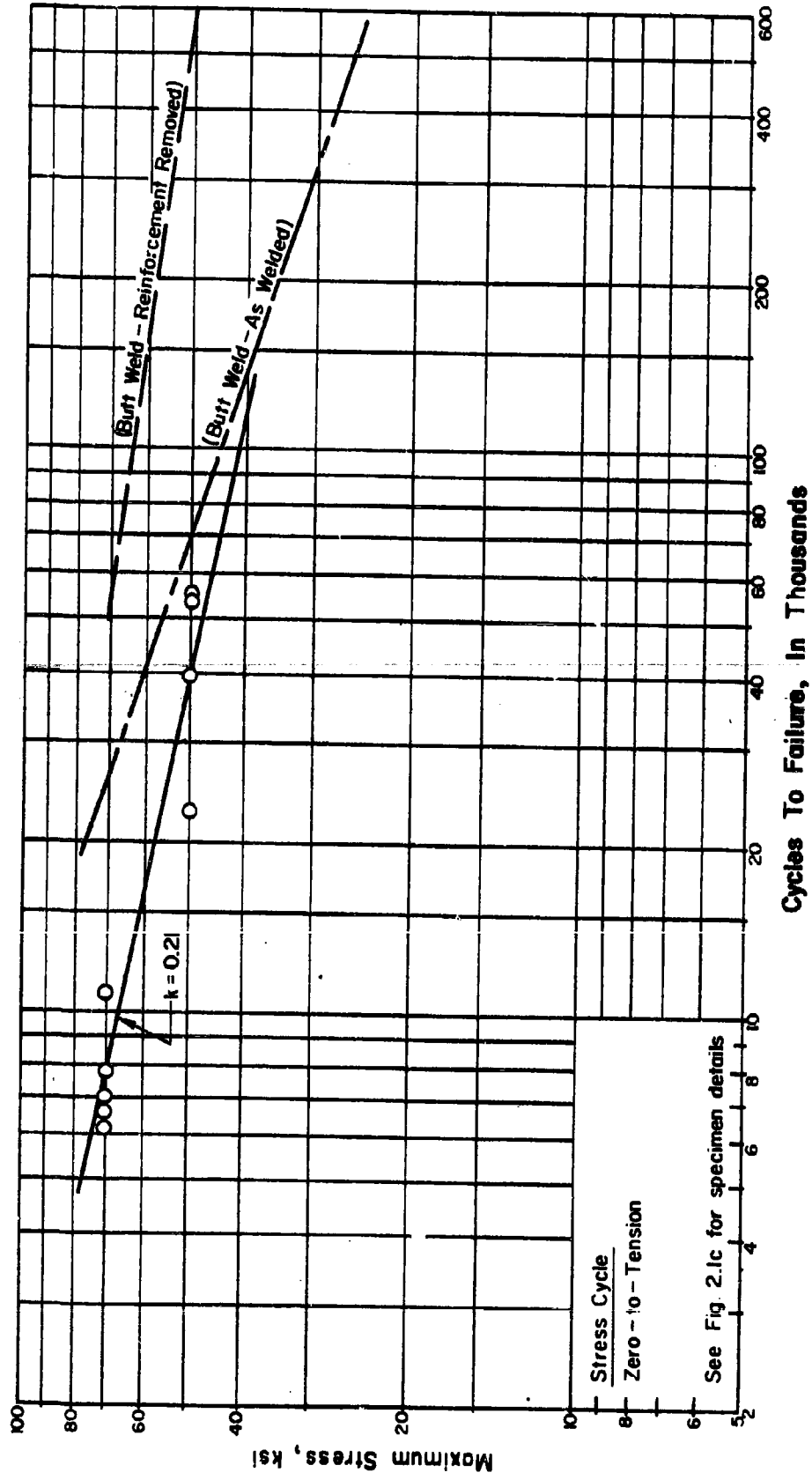
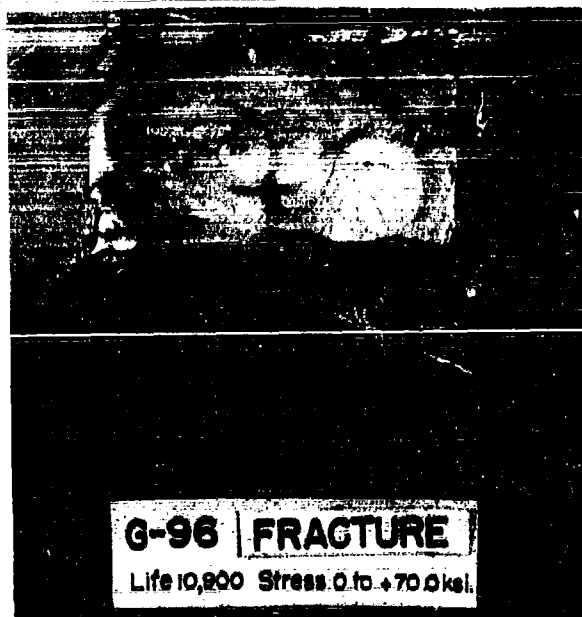

FIG. 4.1 RESULTS OF FATIGUE TESTS OF 1-1/2 IN. TRANSVERSE BUTT WELDS CONTAINING VARIOUS AMOUNTS OF INTENTIONAL POROSITY (REINFORCEMENT REMOVED).



a) POROSITY IN WELD.



b) SLAG IN WELD.

FIG. 4.2 TYPICAL FRACTURES FOR 1-1/2 IN. TRANSVERSE BUTT WELDED JOINTS CONTAINING INTENTIONAL INTERNAL WELD DEFECTS.

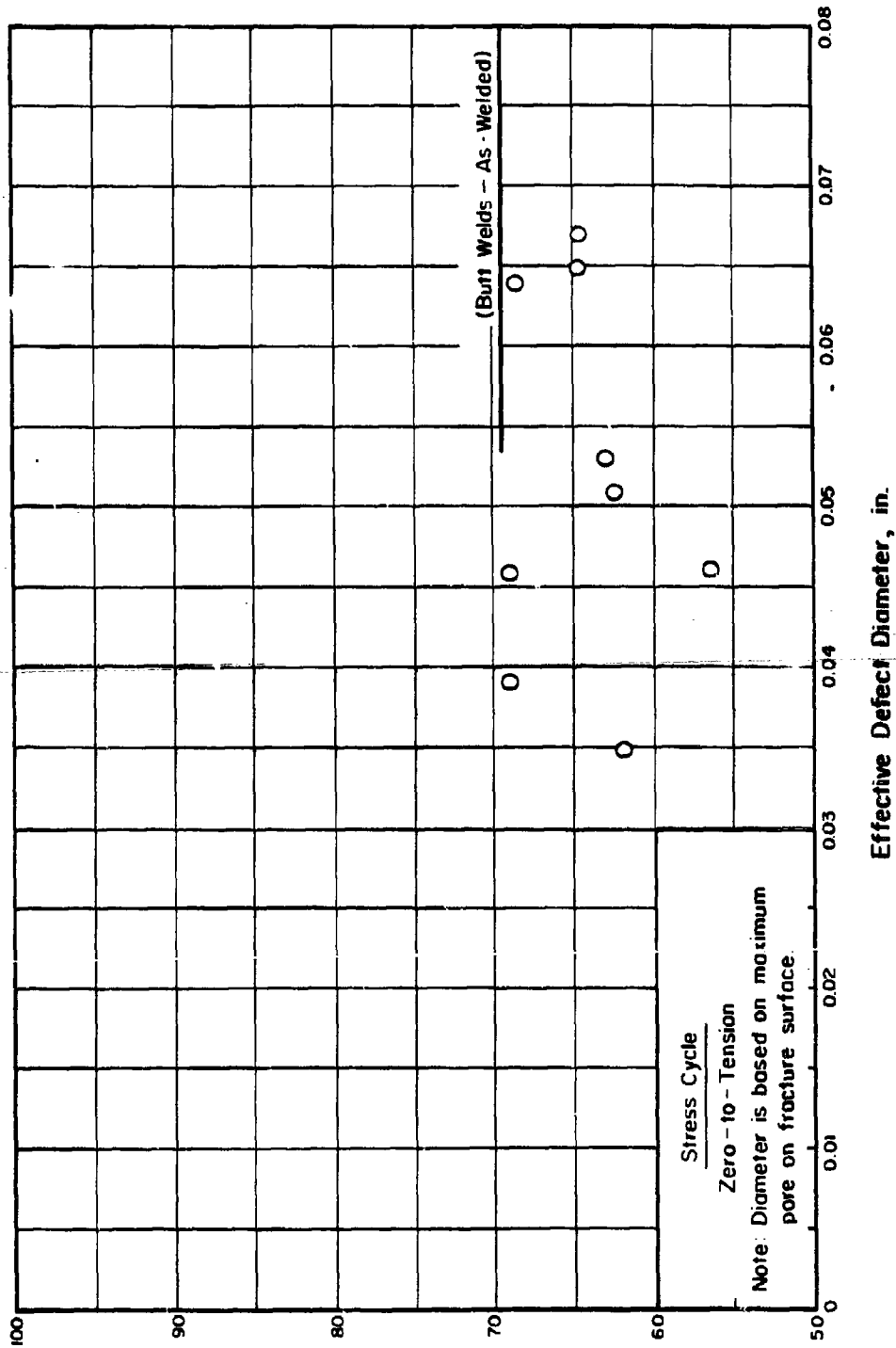

FIG. 4.3 PERCENT FATIGUE STRENGTH AT 100,000 CYCLES vs. EFFECTIVE DEFECT DIAMETER OF POROSITY IN 1-1/2 IN. MATERIAL.

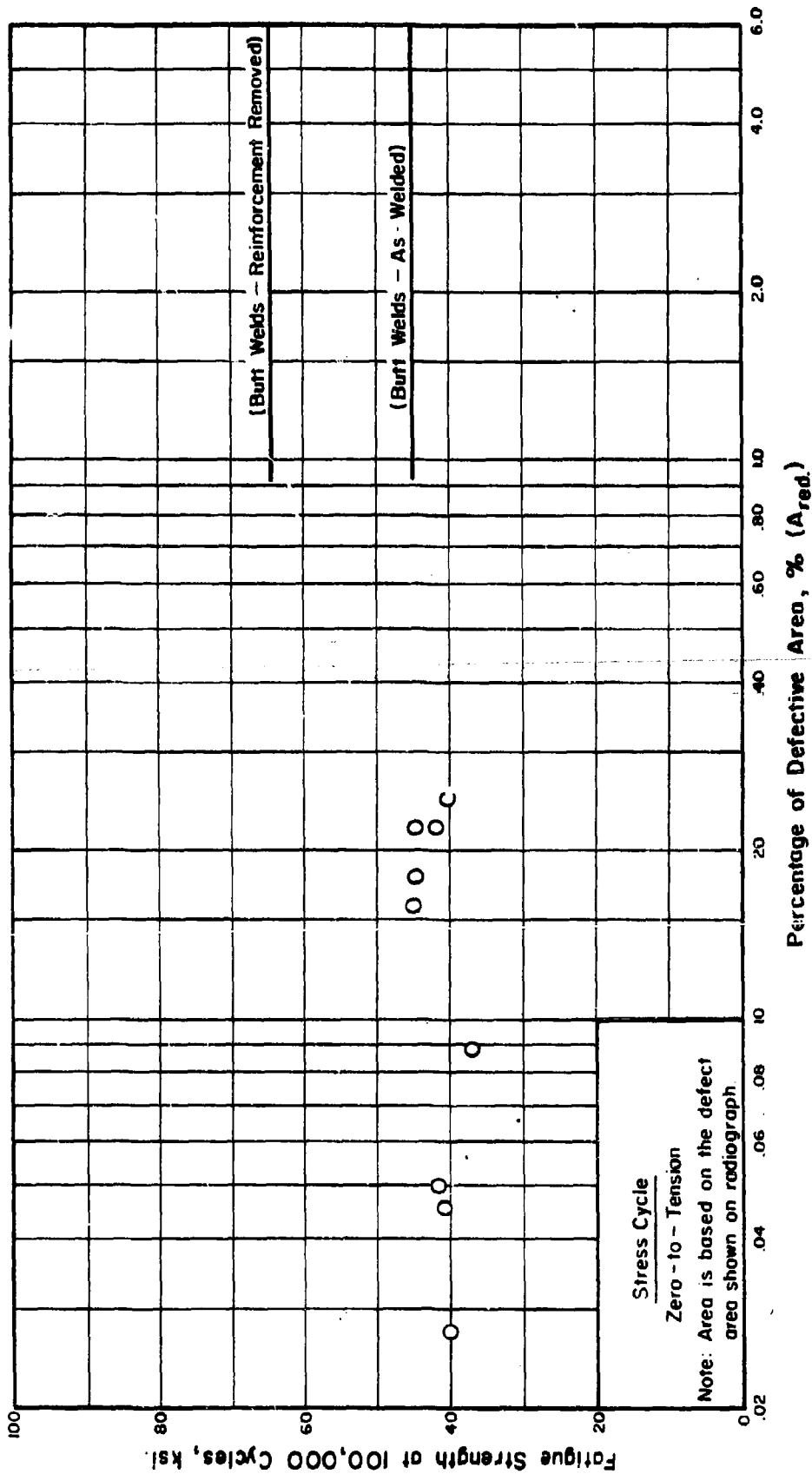

FIG. 4.4 COMPUTED FATIGUE STRENGTH AT 100,000 CYCLES vs. DEFECTIVE AREA DUE TO INTENTIONAL POROSITY IN 1-1/2 IN. MATERIAL.

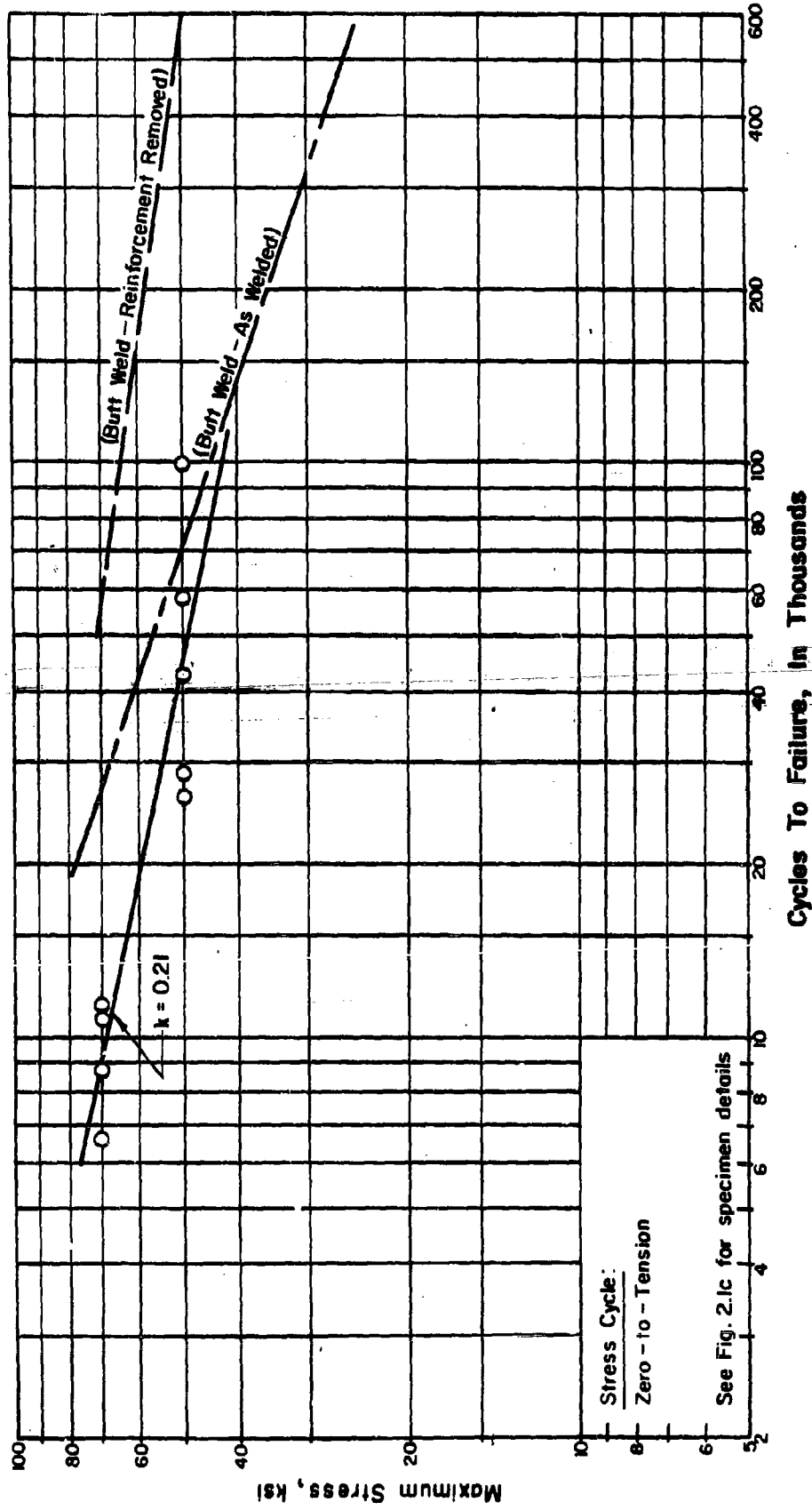

FIG. 4.5 RESULTS OF FATIGUE TESTS OF 1-1/2 IN. TRANSVERSE BUTT WELDS CONTAINING VARIOUS AMOUNTS OF INTENTIONAL SLAG (REINFORCEMENT REMOVED).

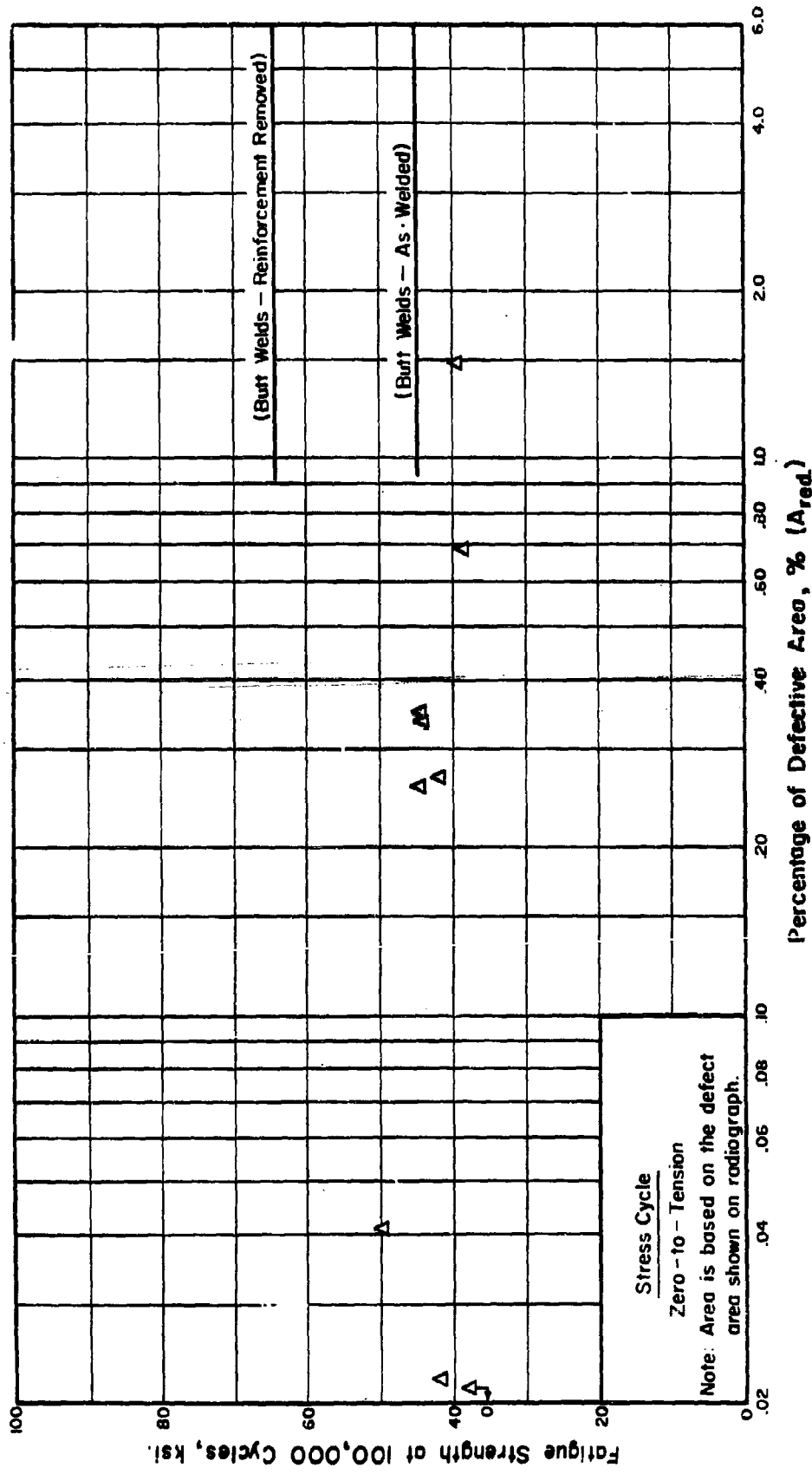
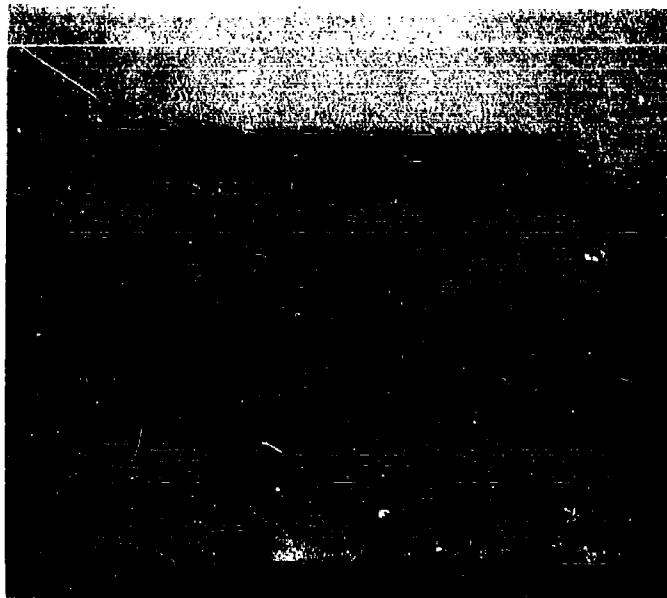

FIG. 4.6 COMPUTED FATIGUE STRENGTH AT 100,000 CYCLES VS. DEFECTIVE AREA DUE TO INTENTIONAL SLAG INCLUSIONS IN 1-1/2 IN. MATERIAL.



ELEVEN DRILLED HOLES IN A ROW.

FIG.4.8 FRACTURE SURFACE OF 3/4 IN. TRANSVERSE BUTT WELDED JOINT CONTAINING ARTIFICIAL INTERNAL WELD DEFECTS.

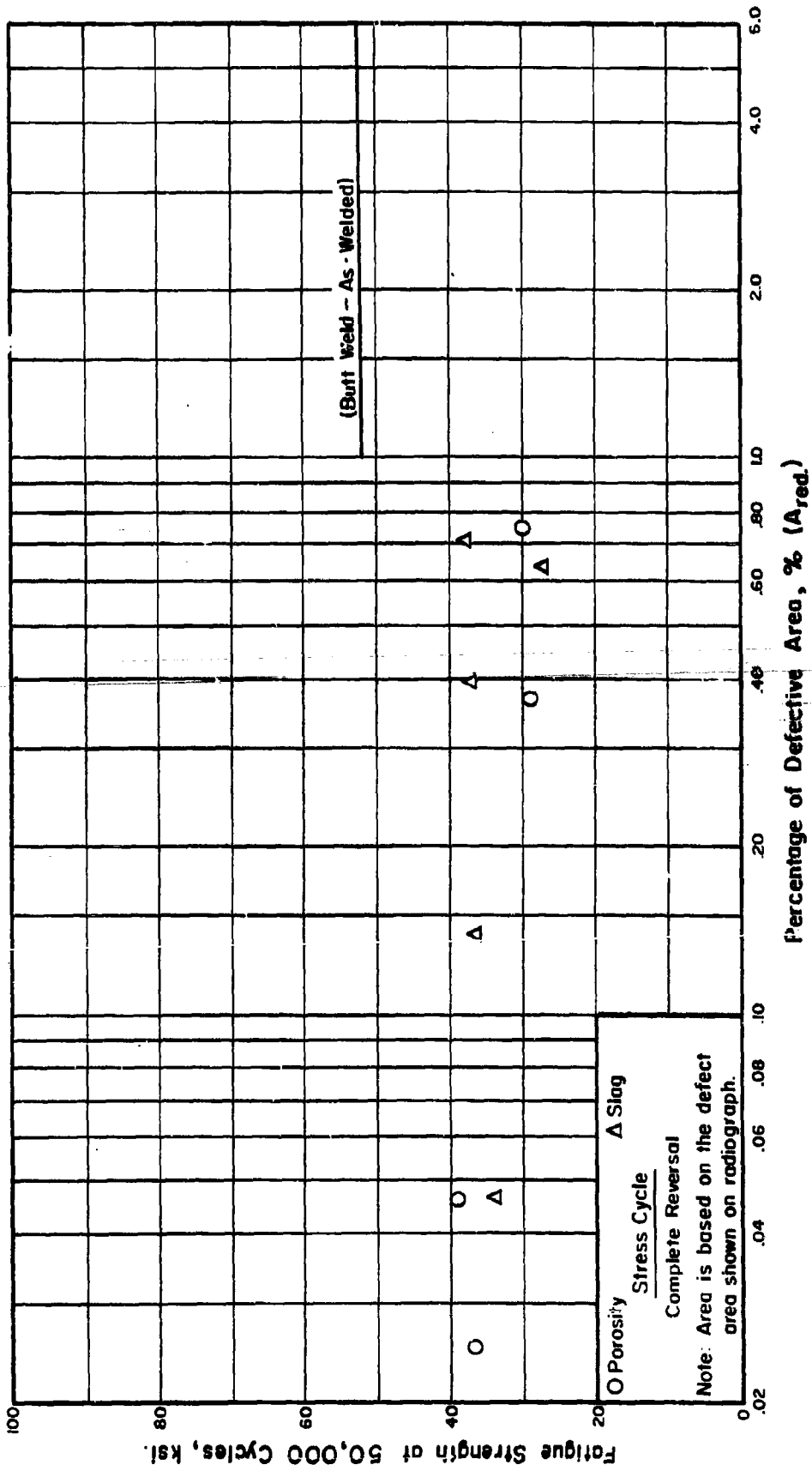

FIG. 4.9 COMPUTED FATIGUE STRENGTH AT 50,000 CYCLES vs. DEFECTIVE AREA DUE TO INTENTIONAL WELD DEFECTS IN 3/4 IN. MATERIAL.

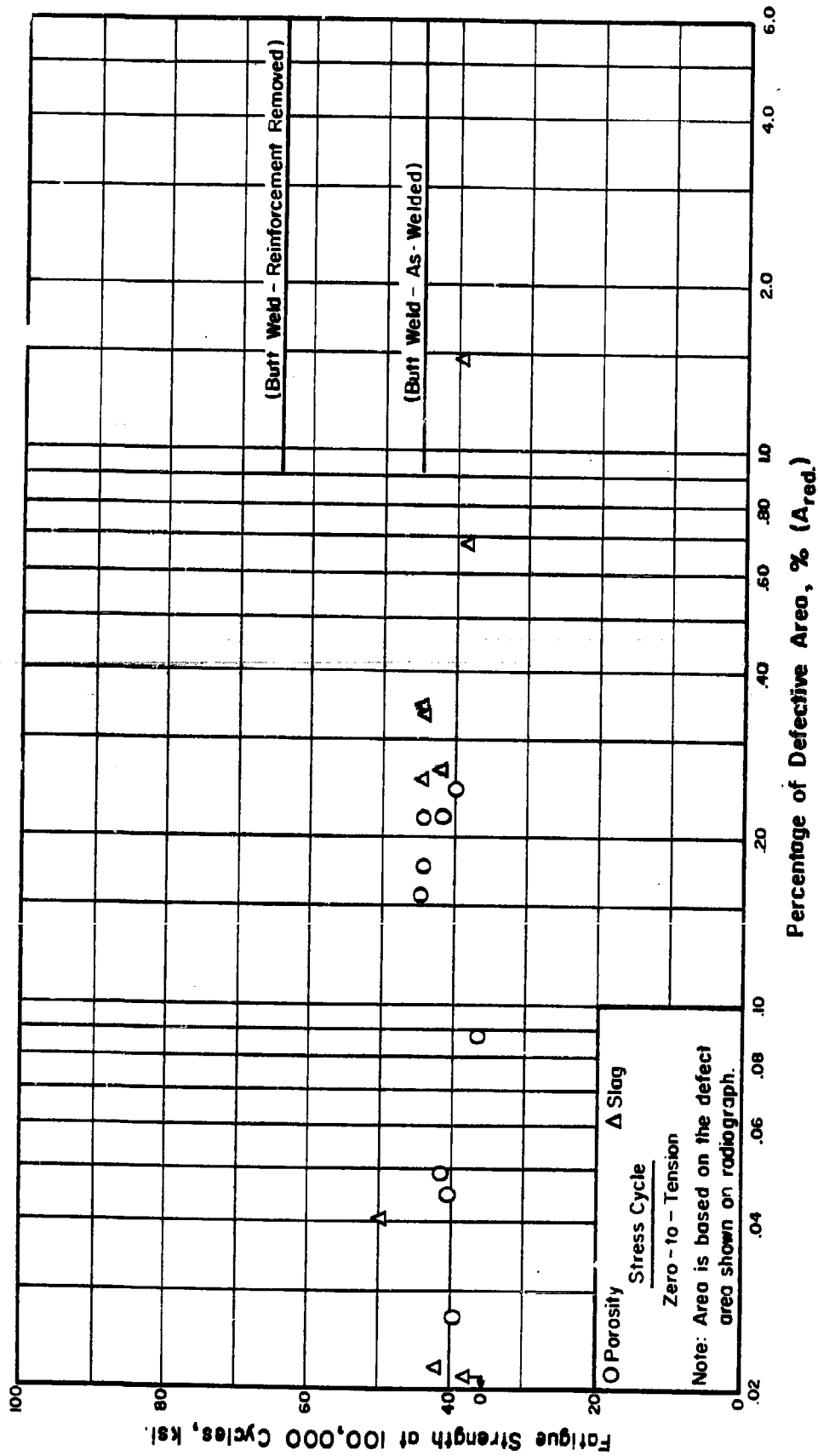

FIG. 4.10 COMPUTED FATIGUE STRENGTH AT 100,000 CYCLES VS. DEFECTIVE AREA DUE TO INTENTIONAL WELD DEFECTS IN 1-1/2 IN. MATERIAL.



a) EQUIPMENT AND LEAD SHIELD IN POSITION.



b) SPECIMEN AND X-RAY FILM HOLDER.

FIG. 5.J SETUP FOR RADIOGRAPHIC STUDY OF
 CRACK PROPAGATION.

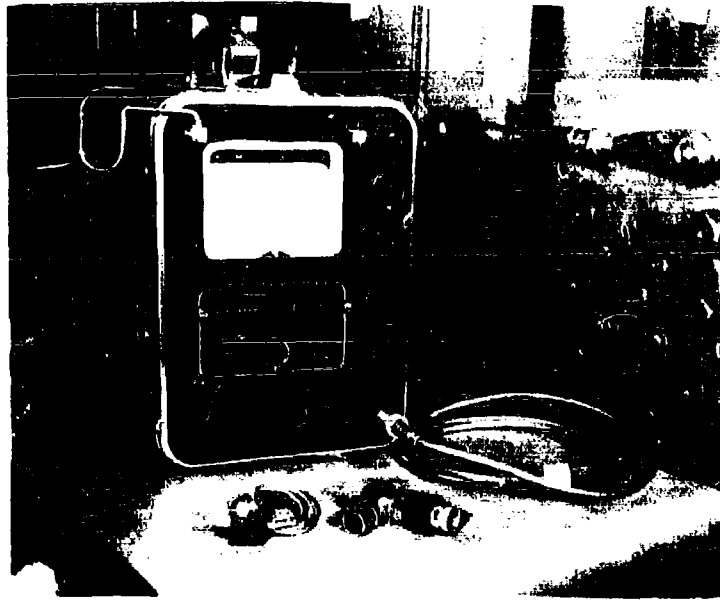

a) EQUIPMENT SHOWING NORMAL AND 45° ANGLE PROBES.

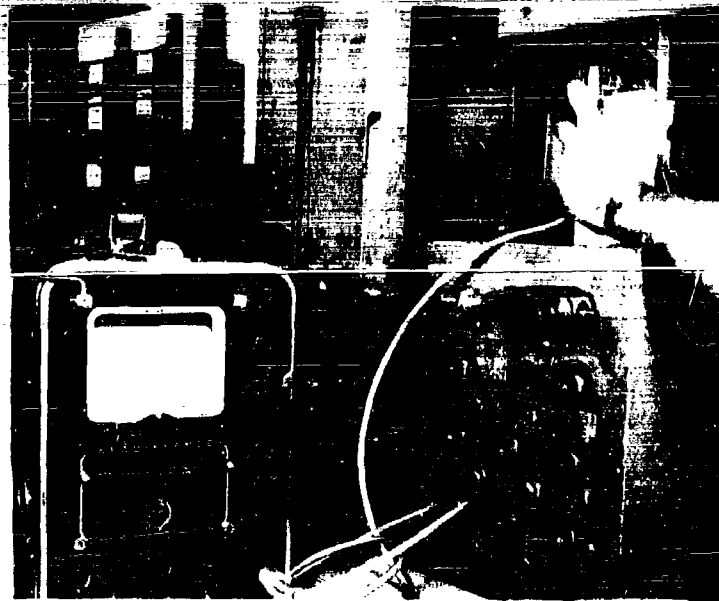

b) EQUIPMENT IN POSITION FOR RECORDING.

FIG. 5.2 SETUP FOR ULTRASONIC STUDY OF
CRACK PROPAGATION.

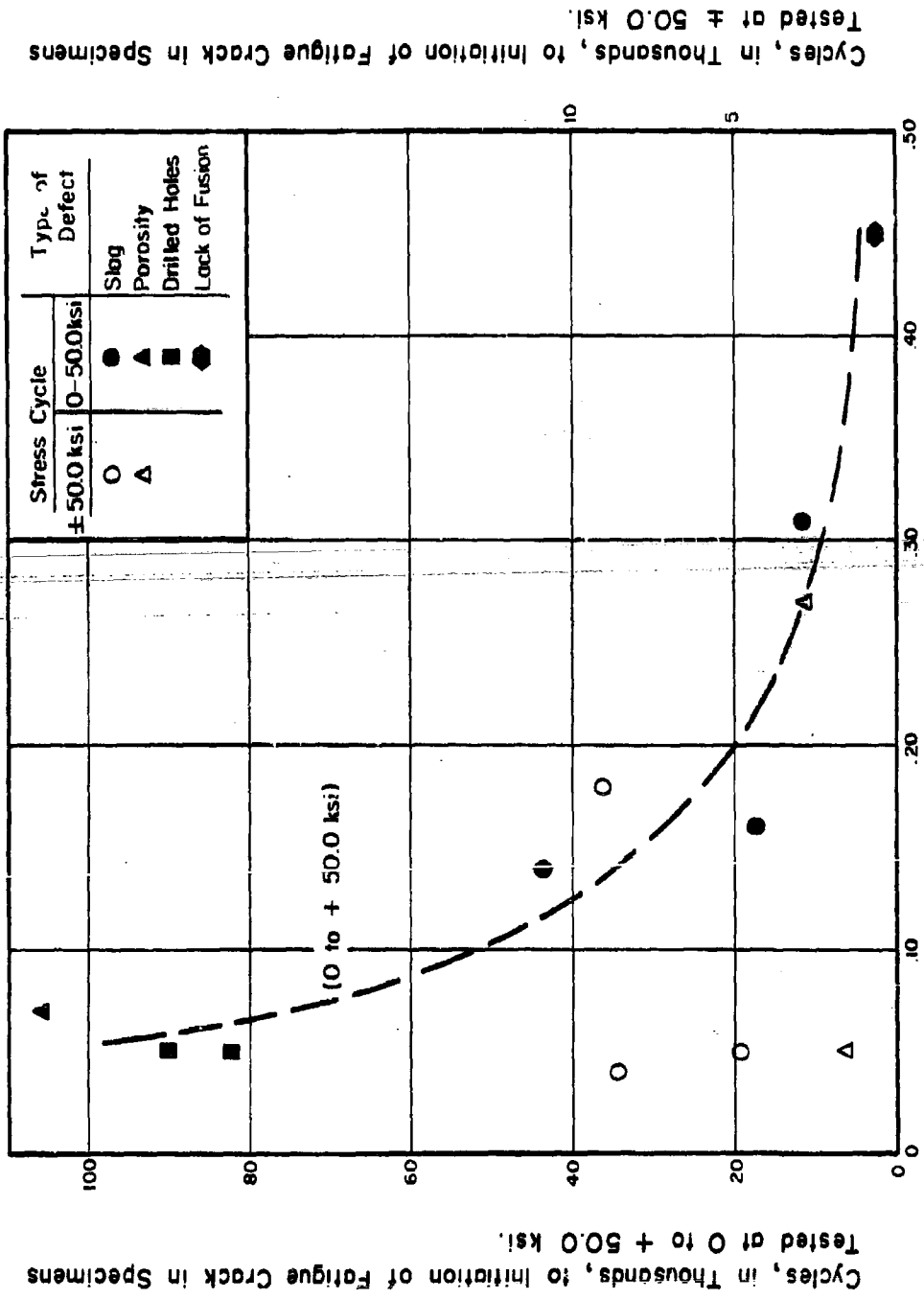
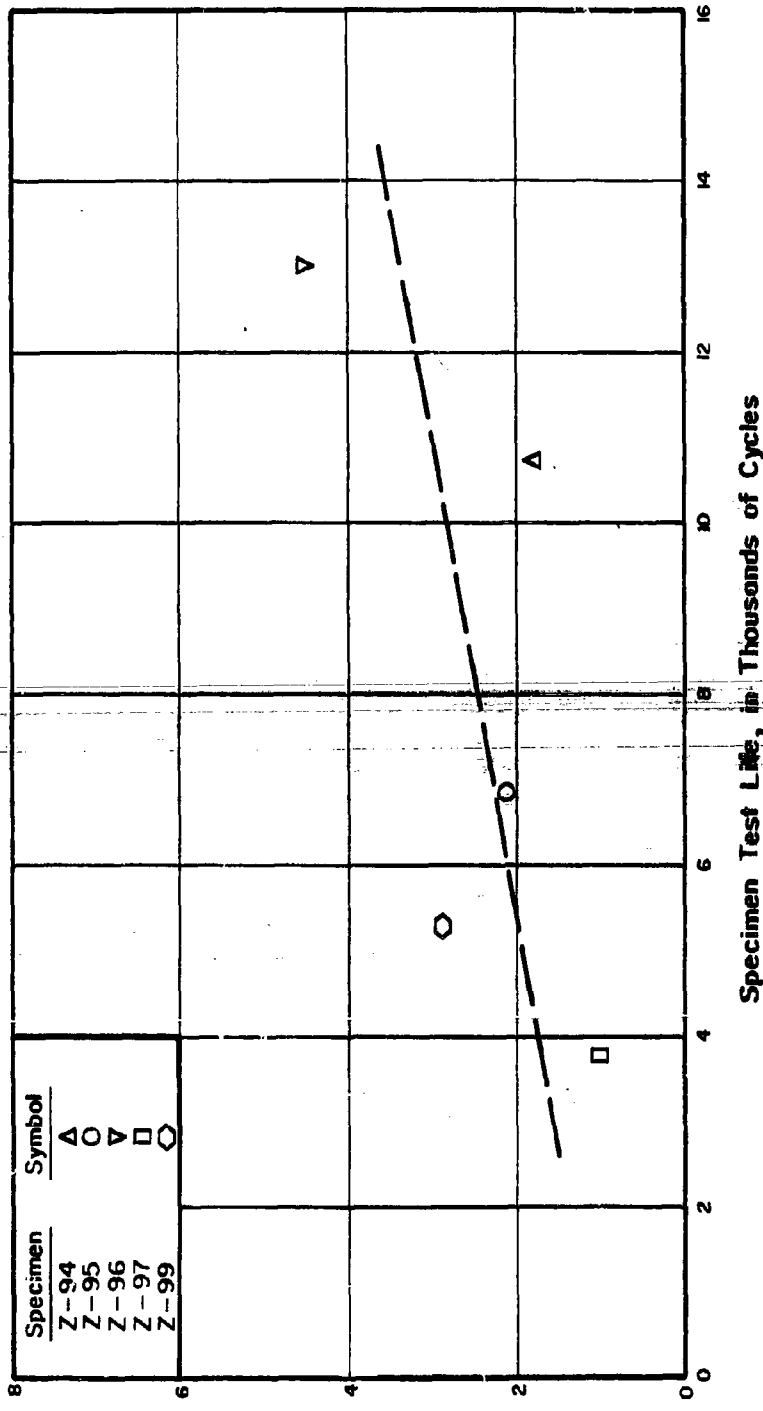

FIG. 5.3 CORRELATION BETWEEN INITIAL LENGTH OF INTENTIONAL WELL DEFECT AND INITIATION OF FATIGUE CRACKS.



Duration of Fatigue Crack Propagation From
Initiation to Test Life, in Thousands of Cycles

FIG. 5.4 COMPARISON OF CYCLES OF FATIGUE CRACK PROPAGATION TO TEST LIFE IN 3/4 IN. HY-80 TRANSVERSE BUTT WELDED SPECIMENS TESTED AT ± 50.0 KSI.

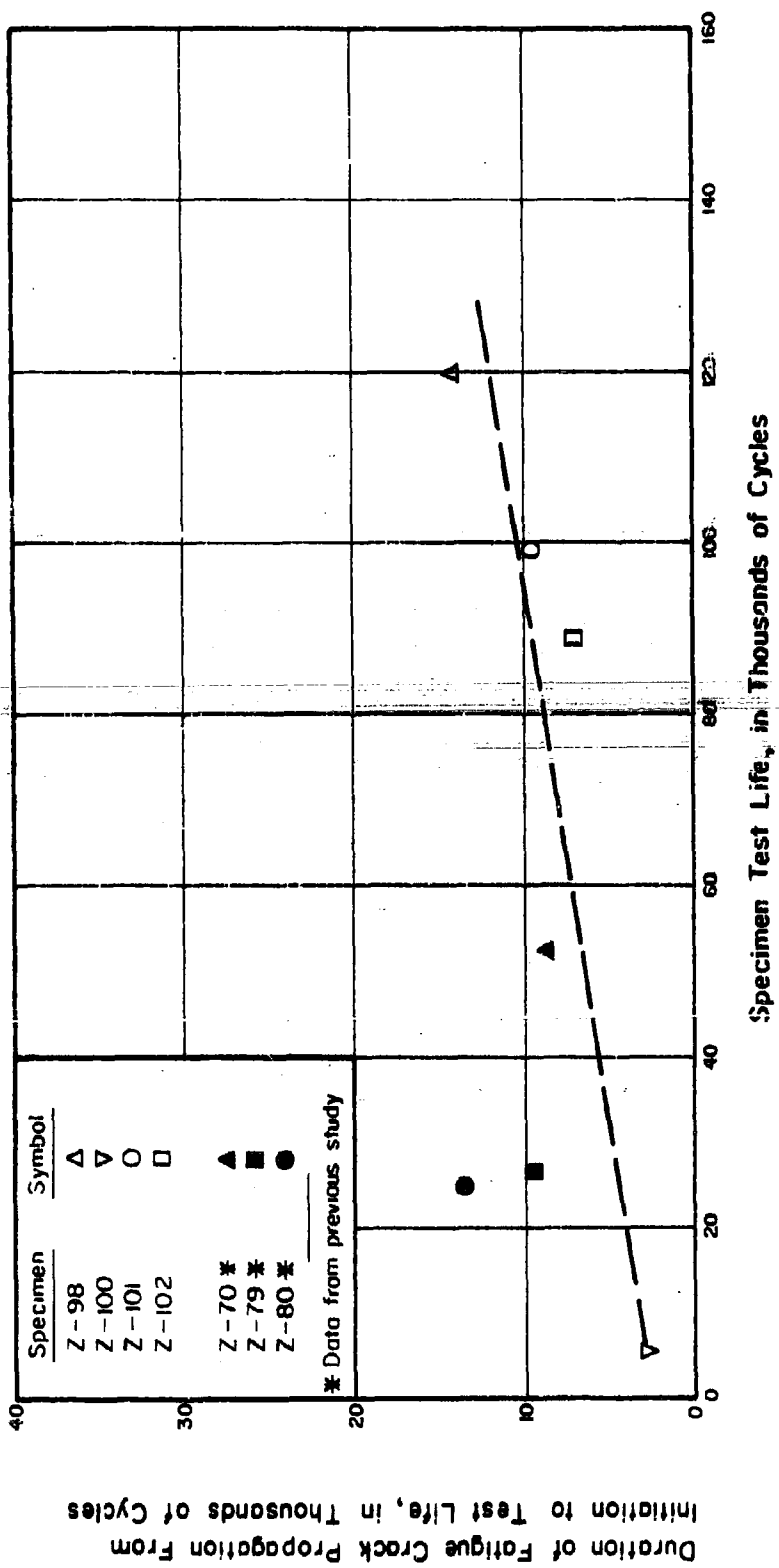

FIG. 5.5 COMPARISON OF CYCLES OF FATIGUE CRACK PROPAGATION TO TEST LIFE IN 3/4 IN. HY-80 TRANSVERSE BUTT WELDED SPECIMENS TESTED AT 0 TO + 50.0 KSI.

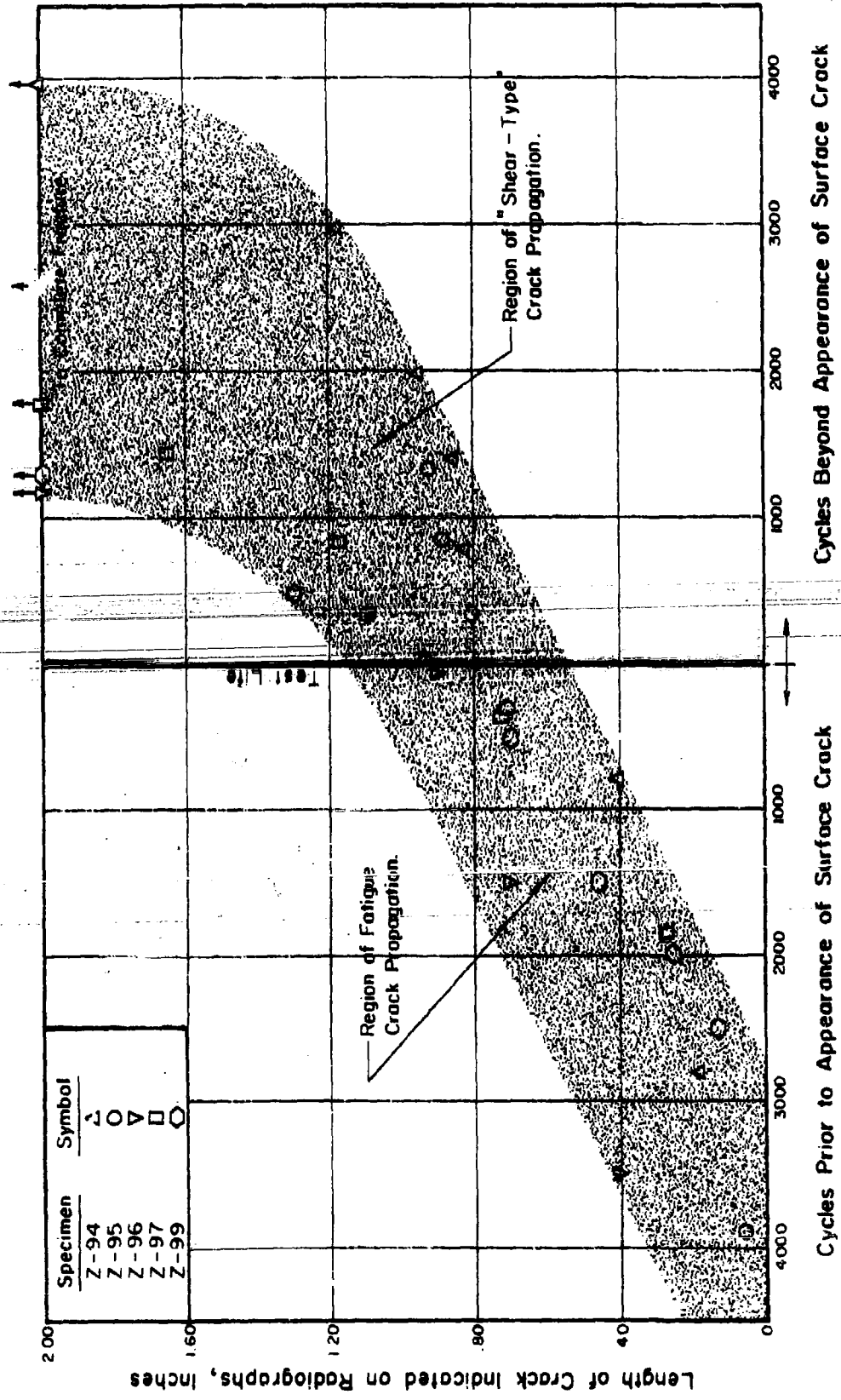

FIG. 5.6 RATE OF CRACK PROPAGATION IN 3/4 IN. HY-80 TRANSVERSE BUTT WELDED SPECIMENS TESTED AT ± 50.0 KSI.

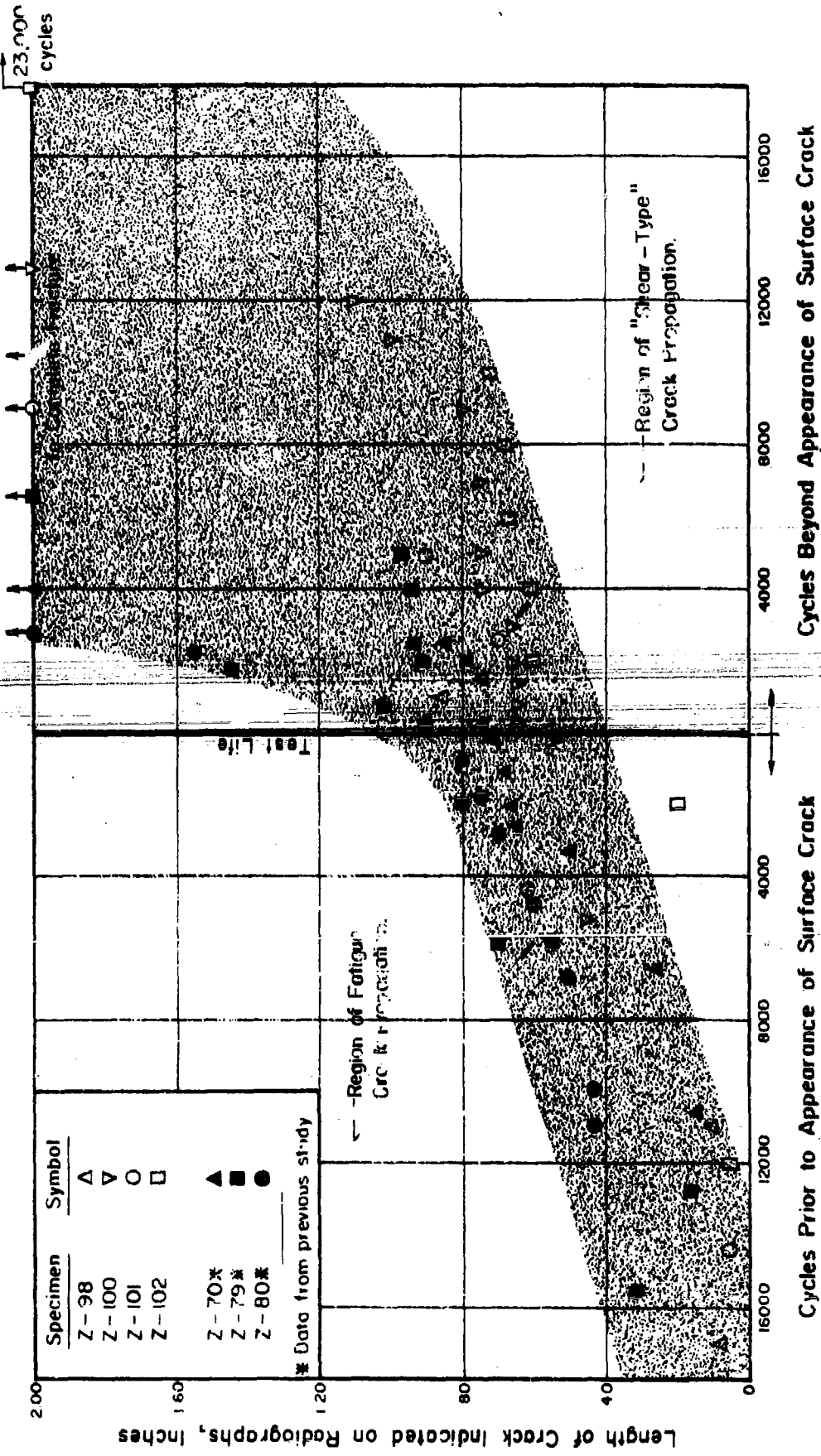

FIG. 5.7 RATE OF CRACK PROPAGATION IN 3/4 IN. HY-80 TRANSVERSE BUTT WELDED SPECIMENS TESTED AT 0 TO + 50.0 KSI.

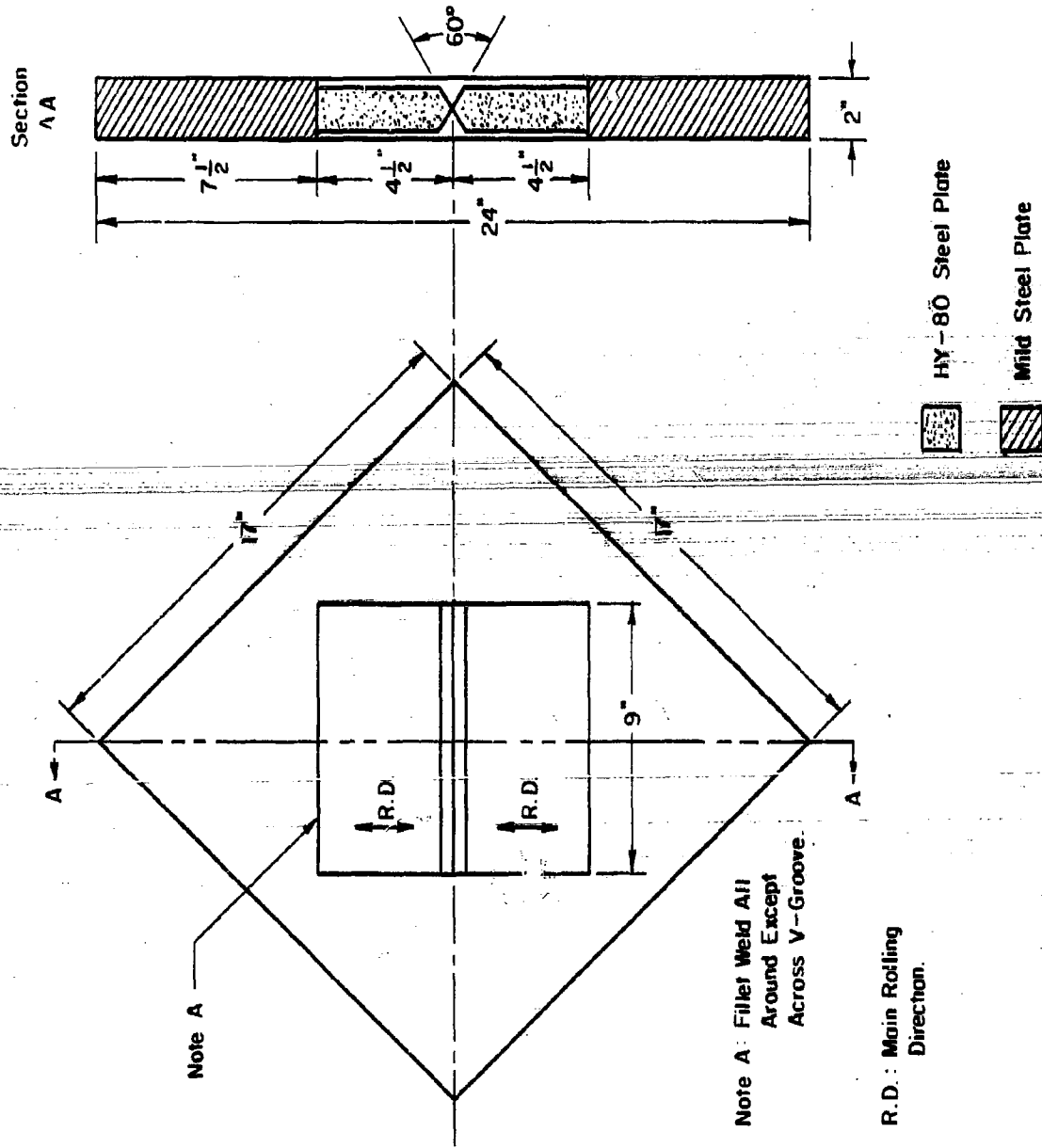

FIG. 6.1 WELDING JIG USED TO RESTRAIN HY-80 STEEL DURING BUTT WELDING.

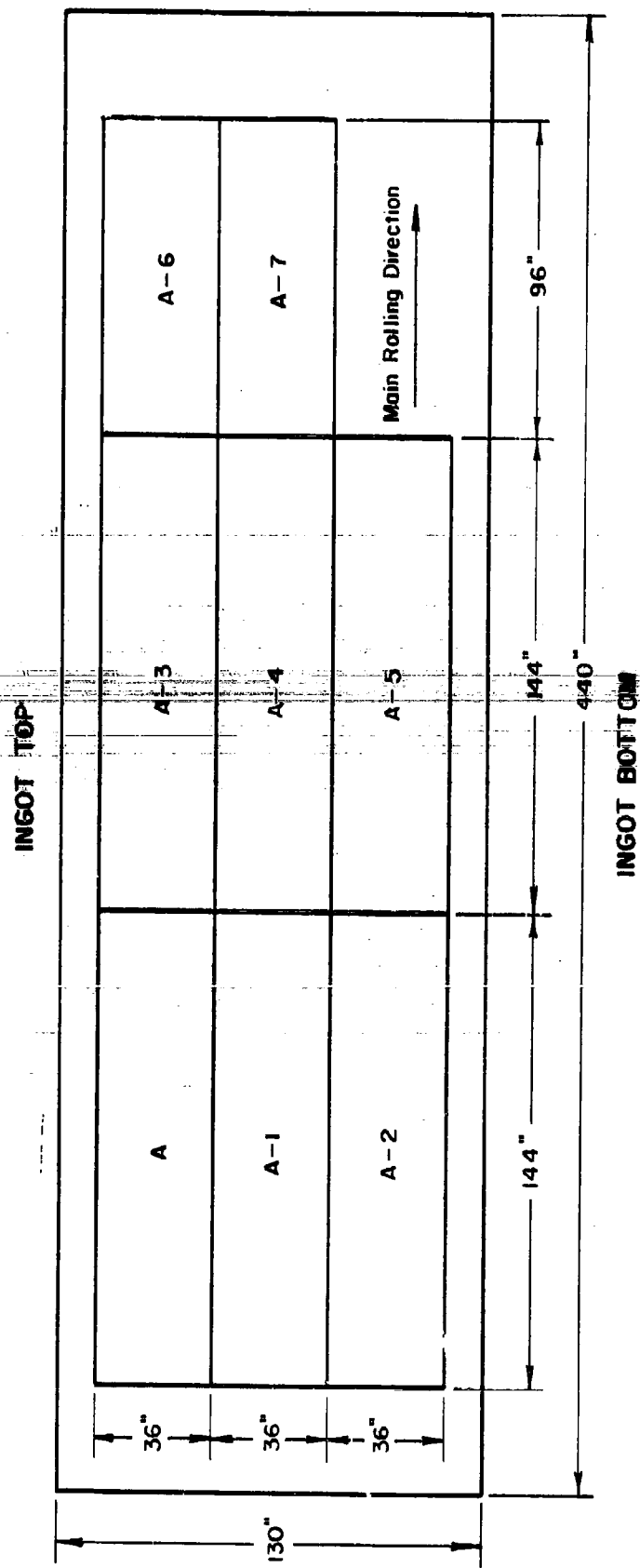
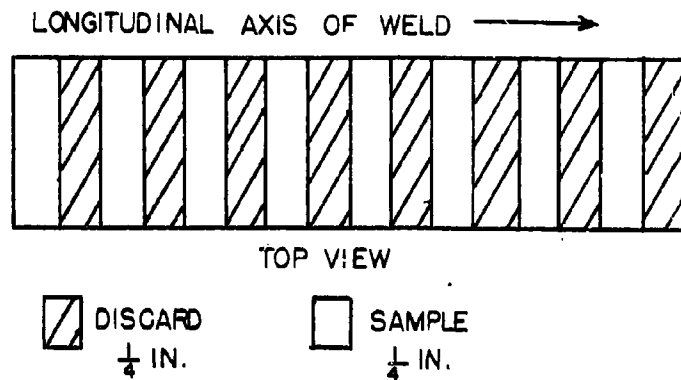
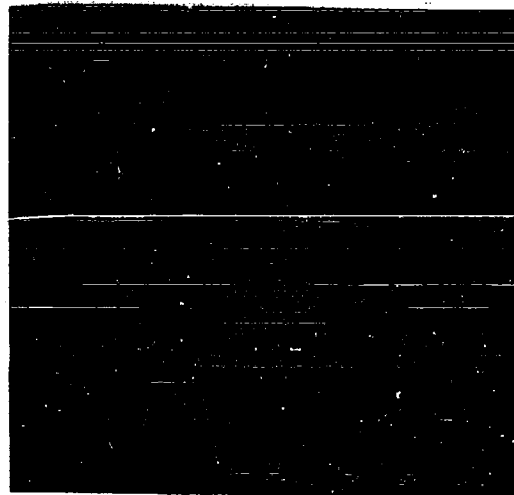

FIG. 6.2 MAIN PLATE OF HY-80 STEEL FROM WHICH TEST PLATES G-67, G-68, AND G-69 WERE OBTAINED.



**FIG 6.3 SECTIONING PLAN FOR METALLOGRAPHIC
SAMPLES OF BUTT WELDED HY-80 STEEL.**



**FIG 6.4 TRANSVERSE SECTION OF A MULTIPASS
BUTT - WELD OF HY-80 STEEL. 2X**

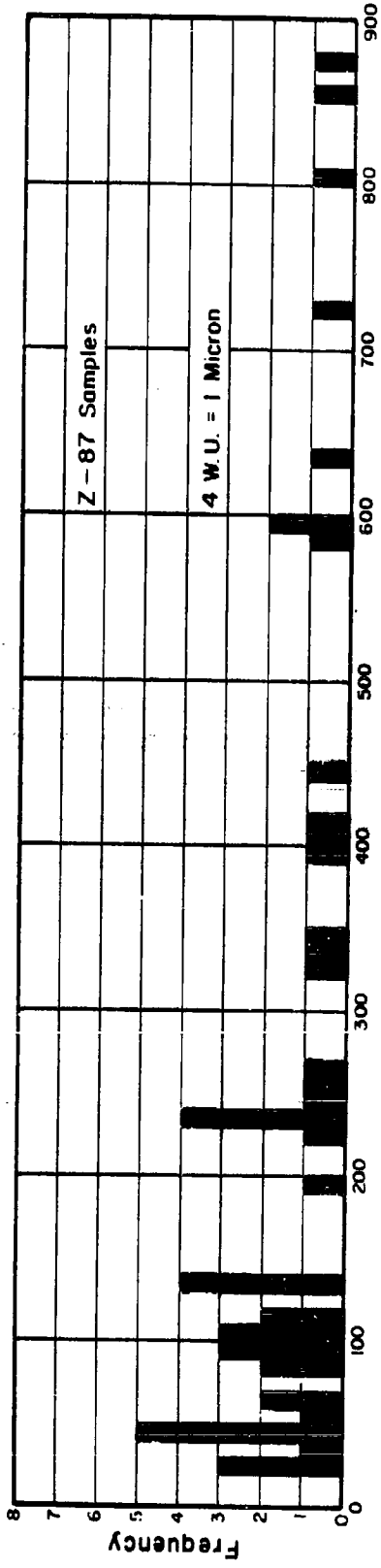

Width Units - (W.U.)

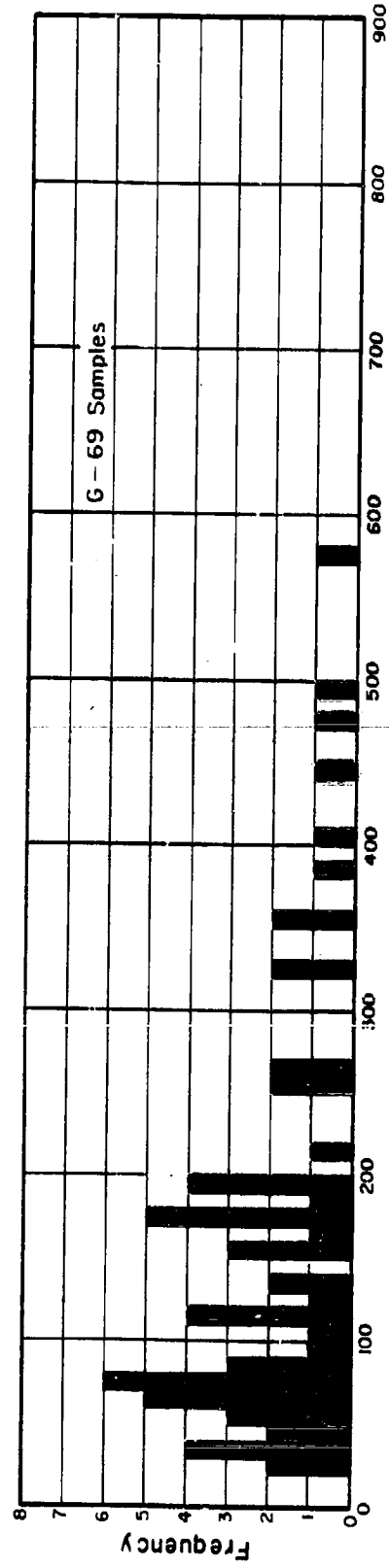

Width Units - (W.U.)

FIG. 6.5 HISTOGRAM OF THE WIDTH OF INCLUSIONS IN THE Z-87 AND G-69 SAMPLES OF HY-80 STEEL.

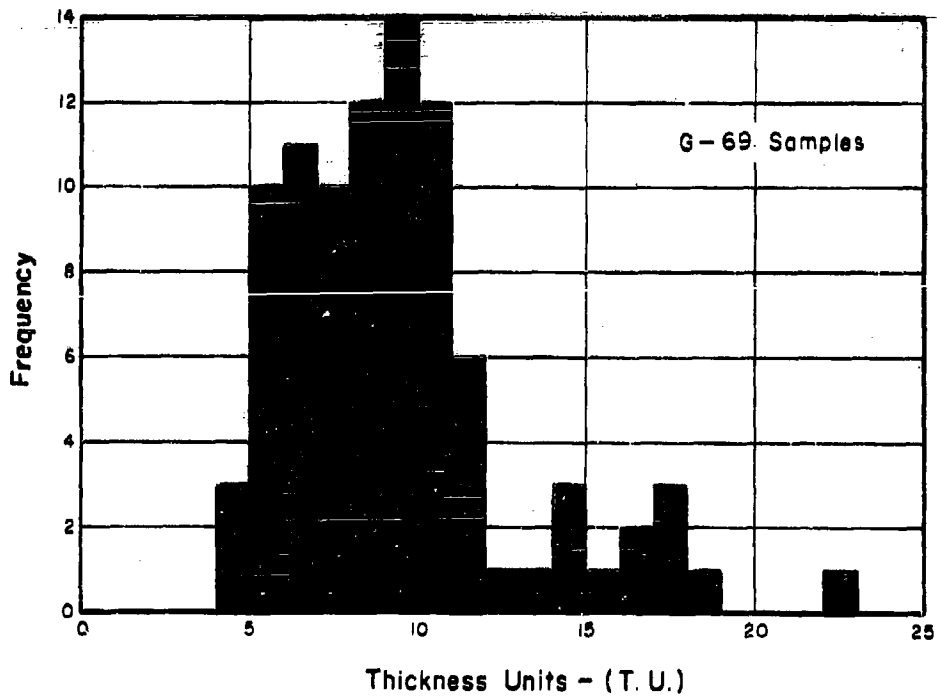
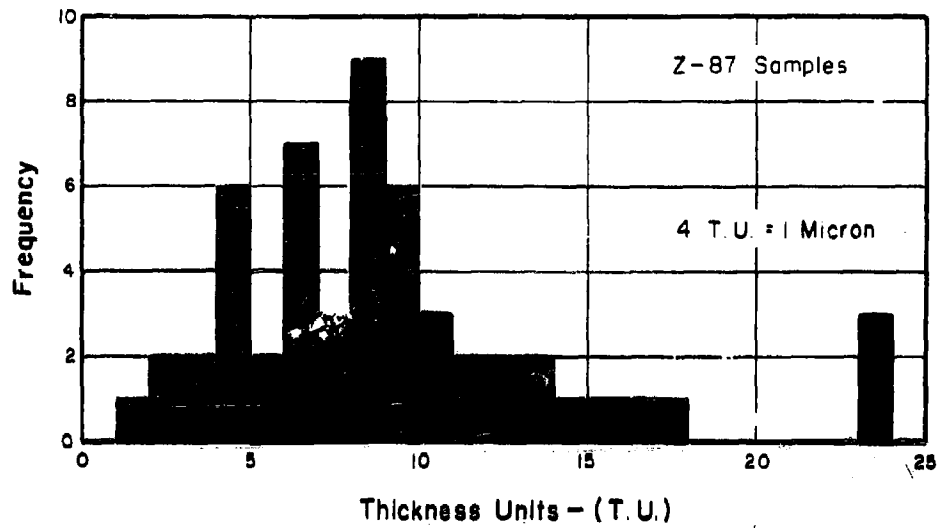
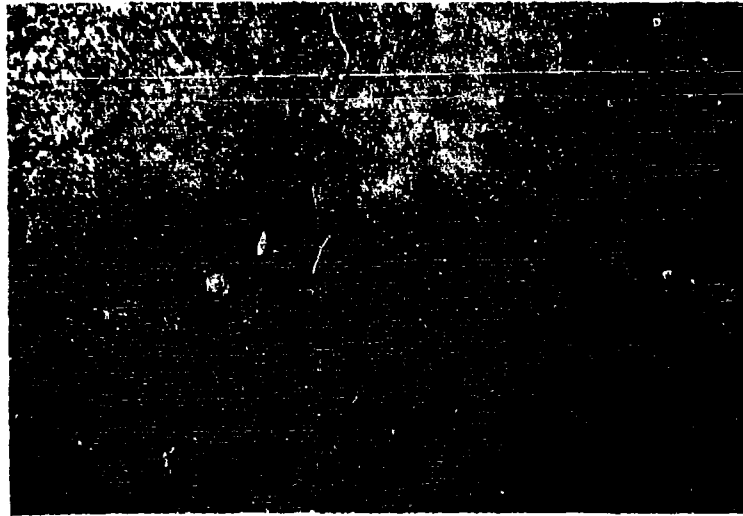
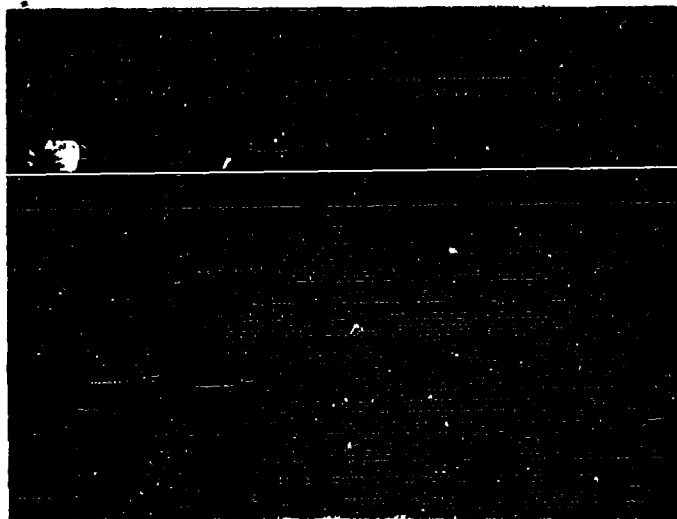

FIG. 6.6 HISTOGRAM OF THE THICKNESS OF INCLUSIONS IN THE Z-87 AND G-69 SAMPLES OF HY-80 STEEL.



**FIG 6.7 PHOTOMICROGRAPH OF A LARGE CRACK IN
THE HAZ AND WELD METAL OF BUTT-WELDED
HY-80 STEEL. 465X**



**FIG 6.8 PHOTOMICROGRAPH OF THE SAME CRACK
SHOWN ABOVE AFTER 0.009 IN. WAS POLISHED
FROM THE TRANSVERSE SECTION. 200X**

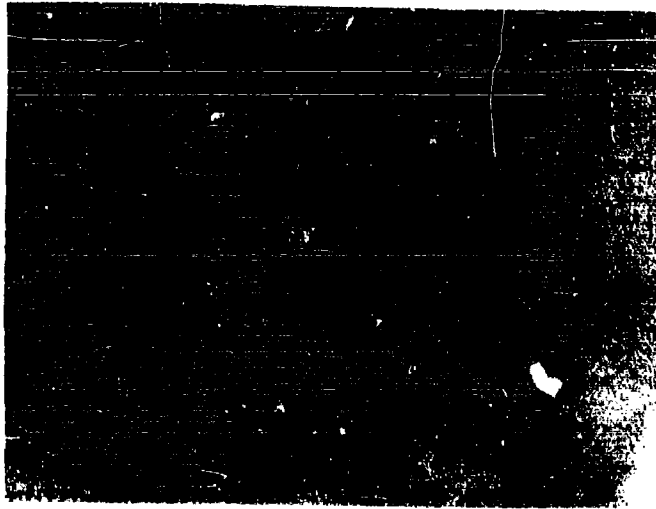

**FIG 6.9 PHOTOMICROGRAPH OF A LARGE CRACK
NOT APPARENTLY ASSOCIATED WITH
INCLUSIONS. 400 X.**

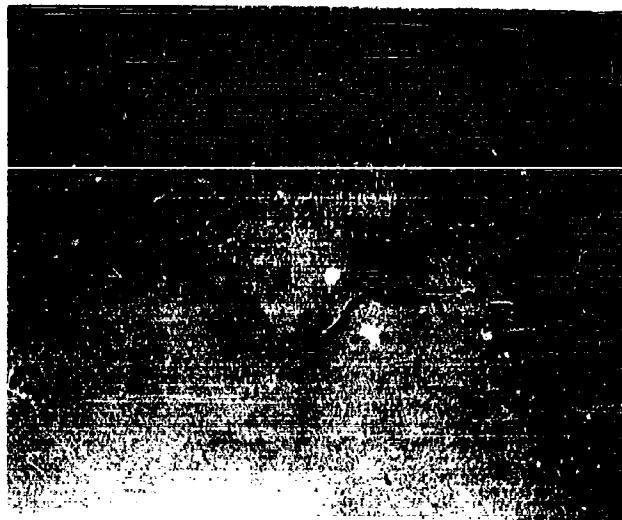

**FIG 6.10 PHOTOMICROGRAPH OF A CRACK ASSOCIATED
WITH POROSITY NEAR UNDERCUT REGION
OF THE WELD. 400 X.**

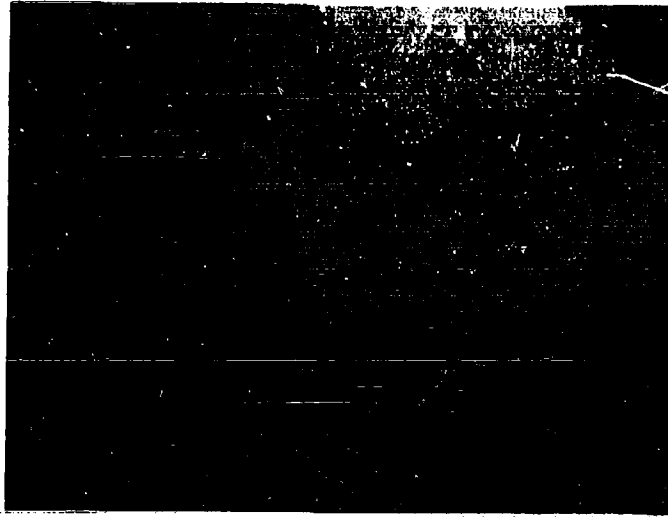

FIG 8.11 PHOTOMICROGRAPH OF A CRACK ALONG
A 'FINGER' OF WELD METAL THAT EXTENDS
INTO THE BASE METAL. 150 X.

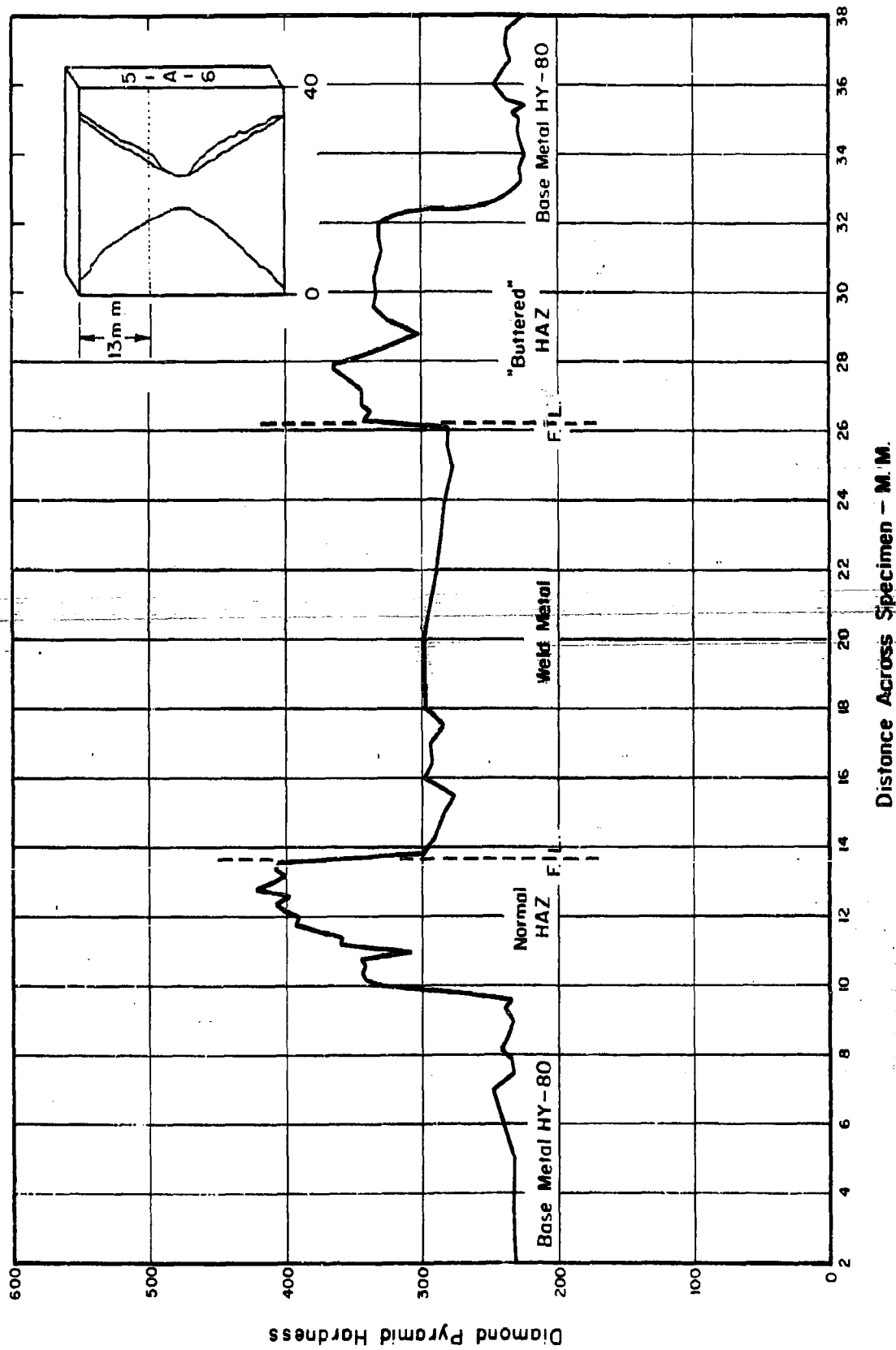

FIG. 6.12 MICRO HARDNESS SURVEY OF 1-1/2 IN. THICK HY-80 STEEL BUTT WELD.

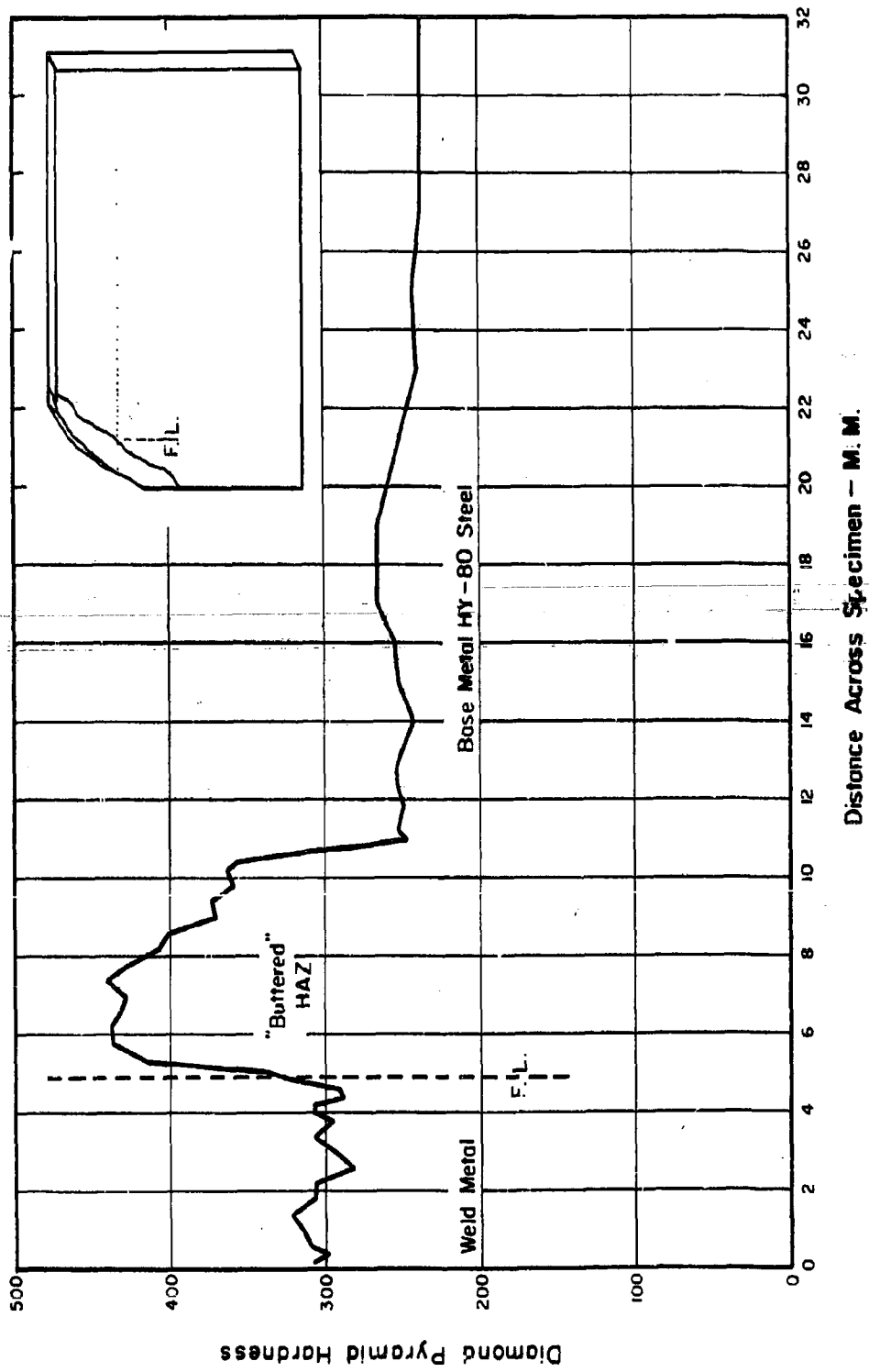
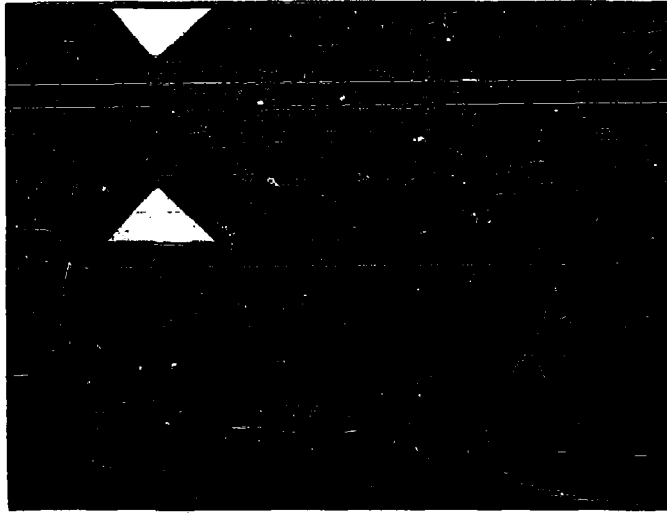

FIG. 6.13 MICRO HARDNESS SURVEY OF THE WELD METAL AND HAZ OF "BUTTERED" HY-80 STEEL SCARF.



**FIG 6.14 FRACTURED SECTION OF HY-80 STEEL
SAMPLE G-68 WELDED IN RESTRAINT.**



**FIG 6.15 TRANSVERSE SECTION OF FRACTURED
SAMPLE INDICATED BY THE ARROW
IN FIG 6.14.**

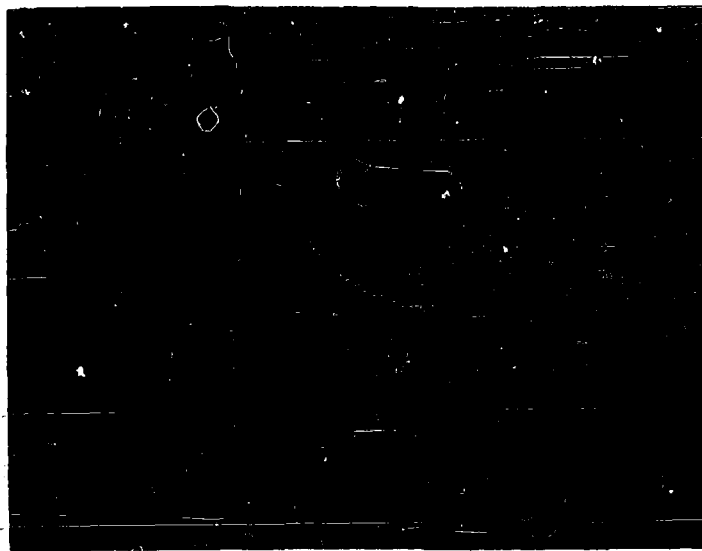

**FIG 6.16 PHOTOMICROGRAPH SHOWING FATIGUE CRACKS
RADIATING FROM POROSITY IN HY-80
STEEL SAMPLE G-68 AFTER 13,000 CYCLES
OF \pm 50,0KSI. 120X.**

APPENDIX A

Ultrasonic Crack Detection Study

The results of the preliminary ultrasonic crack detection study are presented in Table A.1, and plotted in Figs. A.1 and A.2 for tests performed at ± 50.0 ksi and 0 to + 50.0 ksi respectively. As mentioned in the report, ultrasonic readings were taken following each X-ray at various intervals during the life of each specimen. The amplitude of the response as shown on the oscilloscope screen was recorded for each of eight consecutive locations on the specimen surface. Only those response readings corresponding to the location nearest the point of actual crack initiation (as shown by the radiographs) have been recorded in Table A.1. Generally, the other reading locations away from the point of initiation showed considerably less fluctuation until the crack had progressed for some time. It should also be noted that the amplitudes of the responses recorded correspond only to a convenient setting of the ultrasonic equipment and are not meant to be interpreted as a measure of true crack dimensions.

Superimposed on each plot in Figs. A.1 and A.2 are the points where the radiographs first showed the existence of a fatigue crack. The results indicate that the ultrasonic system of detection does show promise as a future means of determining crack initiation in weld specimens. Further experimentation with the techniques of this detection procedure, however, is necessary to improve the reliability of the results.

TABLE A-1
RESULTS OF ULTRASONIC STUDY OF CRACK PROPAGATION

Specimen Z-94		Specimen Z-96		Specimen Z-98		Specimen Z-101		Specimen Z-102	
Cycles	Ultrasonic reading	Cycles	Ultrasonic reading	Cycles	Ultrasonic reading	Cycles	Ultrasonic reading	Cycles	Ultrasonic reading
0	32	0	16	0	30	0	26	0	34
2,000	29	1,000	20	2,000-	35	2,300-	28	2,000-	31
4,000	25	2,000	26	97,000	avg.	69,000	avg.	37,200	avg.
6,000	39	3,600	24	103,000	33	76,000	31	77,100	32
8,000	37	6,100	32	109,000	36	85,000	35	87,000	29
10,000	40	7,600	35	119,000	50	95,100	50	91,000	58
11,600	56	10,000	36	121,000	50	99,500	54	93,100	58
12,200	53	11,600	41			102,000	57	95,000	50
12,800	53	13,100	41			104,400	62	97,000	56
13,800	48	13,200	46					99,000	49

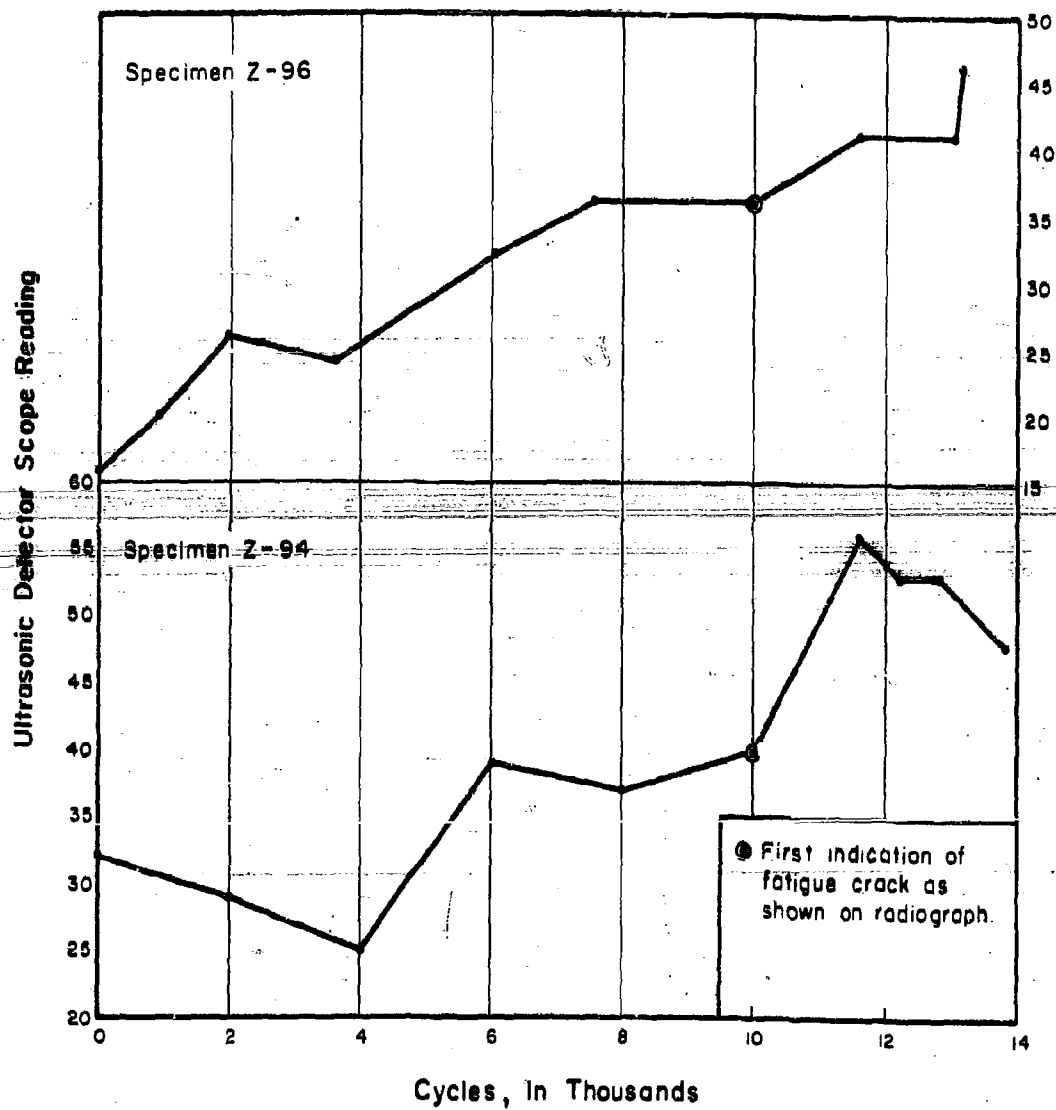

FIG. A.1 RESULTS OF ULTRASONIC CRACK DETECTION STUDY FOR SPECIMENS TESTED AT ± 50.0 KSI.

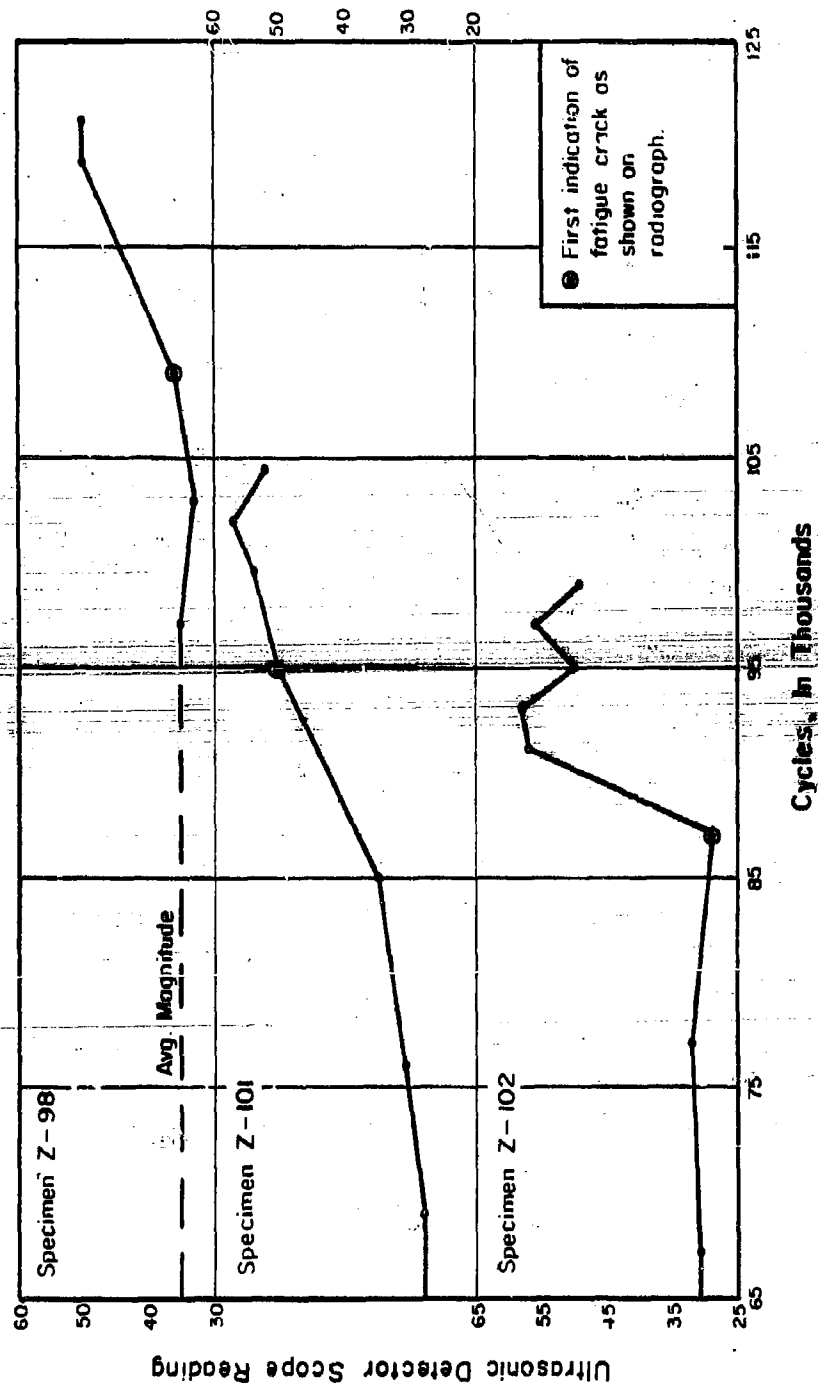

FIG. A.2 RESULTS OF ULTRASONIC CRACK DETECTION STUDY FOR SPECIMENS TESTED AT 0 TO + 50.0 KSI.