

UNCLASSIFIED

AD. 4 5 2 6 7 7L

DEFENSE DOCUMENTATION CENTER

FOR

SCIENTIFIC AND TECHNICAL INFORMATION

CAMERON STATION ALEXANDRIA, VIRGINIA



UNCLASSIFIED

NOTICE: When government or other drawings, specifications or other data are used for any purpose other than in connection with a definitely related government procurement operation, the U. S. Government thereby incurs no responsibility, nor any obligation whatsoever; and the fact that the Government may have formulated, furnished, or in any way supplied the said drawings, specifications, or other data is not to be regarded by implication or otherwise as in any manner licensing the holder or any other person or corporation, or conveying any rights or permission to manufacture, use or sell any patented invention that may in any way be related thereto.

CATALOGED BY D U

AS AD No. 452677 L

**RESEARCH
ANALYSIS
CORPORATION**

**A Methodology
for War Gaming the Adequacy
of Theater Stock Levels**

4 5 2 6 7 7L



LOGISTIC SIMULATION DIVISION
TECHNICAL MEMORANDUM RAC-T-429
Published August 1964

A Methodology for War Gaming the Adequacy of Theater Stock Levels

by
Martin W. Brossman
Walter L. Hughey
Carter B. Magruder
Delbert L. Schroeder
Albert D. Tholen
David B. Webster

DDC AVAILABILITY NOTICE
U. S. Government Agencies may obtain copies of
this report directly from DDC. Other qualified
DDC users shall request through Chief of Research
and Development, Department of the Army,
Washington 25, D. C.
ATTN: R.F. and G.R. Division



RESEARCH ANALYSIS CORPORATION
McLEAN, VIRGINIA

FOREWORD

The Logistic Simulation Division, which has prepared this report, is responsible for the development of techniques for and the conduct of logistic simulation and war gaming. In order to accomplish this mission effectively, division activities have been divided into three tasks: operational gaming and simulation, model building, and methodology development. The operational gaming and simulation task is directed toward solving immediate problems with current capabilities and providing continued inputs and current experience for the accomplishment of the other tasks. The model-building task is concerned with the development of a more comprehensive logistic simulation and war-gaming capability. The methodology development task is devoted to devising the fundamental mathematical techniques required for gaming and simulation. This report is a product of the operational gaming and simulation effort, i.e., it describes a methodology developed for use in war games to evaluate the adequacy of stock levels. Examples of the use of this methodology in a war game are provided to illustrate its application under one set of circumstances.

The type of war game based on this methodology is not the standard two-sided Red-vs-Blue game. Instead a Blue logistics team attempts to meet the support requirements of the forces and campaign presented in a previously developed scenario. An operations player implements and interprets interactions of the logistics play with this scenario; a Controller staff evaluates the logistic interactions and monitors and controls the game play. The logistic players, who represent all major phases of logistic support, in and to the theater of operations, resolve requirements for TOE support units, classes of supply, and sea, air, and land transportation. Game competition is reflected both in the availability of assets to meet specific support requirements and in the necessity of trading, or balancing, materiel and manpower resources. Games of the type described here represent a compromise between the standard Red-vs-Blue military game and an analytical study of a combat-support situation. They focus more detailed attention on the problem of Blue support and are especially useful when there are no complementary analytical studies of the same problem.

An attempt has been made to present sufficient detail in this methodology memorandum to permit its use by the Army as a manual for organizing, administering, and playing similar war games.

Martin W. Brossman
Chief, Logistic Simulation
Division

FOREWORD

The Logistic Simulation Division, which has prepared this report, is responsible for the development of techniques for and the conduct of logistic simulation and war gaming. In order to accomplish this mission effectively, division activities have been divided into three tasks: operational gaming and simulation, model building, and methodology development. The operational gaming and simulation task is directed toward solving immediate problems with current capabilities and providing continued inputs and current experience for the accomplishment of the other tasks. The model-building task is concerned with the development of a more comprehensive logistic simulation and war-gaming capability. The methodology development task is devoted to devising the fundamental mathematical techniques required for gaming and simulation. This report is a product of the operational gaming and simulation effort, i.e., it describes a methodology developed for use in war games to evaluate the adequacy of stock levels. Examples of the use of this methodology in a war game are provided to illustrate its application under one set of circumstances.

The type of war game based on this methodology is not the standard two-sided Red-vs-Blue game. Instead a Blue logistics team attempts to meet the support requirements of the forces and campaign presented in a previously developed scenario. An operations player implements and interprets interactions of the logistics play with this scenario; a Controller staff evaluates the logistic interactions and monitors and controls the game play. The logistic players, who represent all major phases of logistic support, in and to the theater of operations, resolve requirements for TOE support units, classes of supply, and sea, air, and land transportation. Game competition is reflected both in the availability of assets to meet specific support requirements and in the necessity of trading, or balancing, materiel and manpower resources. Games of the type described here represent a compromise between the standard Red-vs-Blue military game and an analytical study of a combat-support situation. They focus more detailed attention on the problem of Blue support and are especially useful when there are no complementary analytical studies of the same problem.

An attempt has been made to present sufficient detail in this methodology memorandum to permit its use by the Army as a manual for organizing, administering, and playing similar war games.

Martin W. Brossman
Chief, Logistic Simulation
Division

ACKNOWLEDGMENTS

Contributions made by members of the Army staff, especially those associated with logistic planning and gaming, have assisted greatly in the development of this methodology.

The Project Advisory Group chaired by Mr. L. H. Todd of the Office, DCSLOG, has made substantial contributions in the form of guidance and critique.

Mutual exchanges of ideas between RAC and the Engineer Strategic Studies Group (ESSG) of the Office, Chief of Engineers, in previously completed games have greatly facilitated the development of this methodology. Major individual contributions were made by Lt Col R. A. Brandt, Lt Col R. W. Boberg, and Maj A. A. Frick. Col S. W. Dziuban and Col W. R. Kleysteuber, Chief and Deputy Chief of ESSG, respectively, have provided a propitious environment at ESSG for mutual exchanges of ideas and individual contributions.

Considerable aid was given by Mr. K. F. Mineau and other members of the Office, Chief of Transportation, especially in those areas involving transportation analyses and design of the computer program.

Finally acknowledgment is made of the valuable suggestions of the RAC review board consisting of Col L. S. Simcox, USA (Ret), Chairman; Mr. G. E. Cooper, Mr. R. McQuie, and Lt Col N. W. Parsons, USA (Ret).

CONTENTS

Foreword	iii
Acknowledgments	iv
Summary	1
Problem—Facts—Discussion—Conclusions	
Abbreviations	8
1. Introduction	9
Organization—Purpose—Background—Scope—Game Play Parameters— Computer Assistance—Game Flow and Form Requirements	
2. Game Organization	28
General—Controller Responsibilities—Players and Player Responsi- bilities—Game Schedule—Game Facilities	
3. Pregame Preparation	35
General—Guidance Papers—Other Essential Information—Player Designation and Briefing and Game Organization	
4. Game Play	41
Initiation of Play—Phases and Steps of Play—Intertheater Analysis— Intratheater Analysis	
5. Postgame Activity	70
General—Review and Final Game Report	
Appendixes	
A. Tactical Scenario	73
B. Administrative-Support Plan	79
References	87

Figures

1. General Game Flow Chart	12
2. Sample Theater Organization	14
3. Game Parameters, Objective Area	20
4. Game Parameters, Nonobjective Areas	20
5. General Flow Chart for Supply-Tonnage Requirements Program	22
6. Detailed Game Flow Chart	23
7. Form Flow Chart	26
8. Game Organization	28
9. Suggested Game Schedule	33
10. Typical Game Floor Plan	34
11. Pregame Preparation Flow Chart	35
12. Form 2, Troop List	37
13. Form 1, Planning Factors	38
14. Game Play, Flow Chart	42
15. Form 3, Population by User by Region	44
16. Theater Population Determination	45
17. Form 4, Population by Player by Region, Controller Worksheet	46
18. Population Consolidation	47
19. Form 5, Population by User by Region, Controller Summary	49
20. Form 5a, Computer Input; Population Data	50
21. Form 6, Computer Output: Supply-Tonnage-Requirements Report	51
22. Form 8, Theater Bulk POL Tonnage Report	52
23. Procedures for Stock-Level Analysis in Any Region	55
24. Form 10, Computation of Authorized Theater Reserves	56
25. Form 7a, Supply Voucher, Example	57
26. Form 7b, Supply Ledger Sheet, Example	58
27. Portrayal of Stock-Level Analysis Results	59
28. Form 11, Distribution of Transportation Workload	60
29. Form 12, Objective Area Incoming Tonnage Report	62
30. Form 13, Objective Area LOC Movement	64
31. Form 14, Phased Facility Requirements	65
32. Postgame Activity Flow Chart	71

Tables

1. Time Periods, Second DCSLOG Game	13
2. Classes of Supply	16
3. Supply Consumption Factors: Objective Area	17
4. Supply Consumption Factors: Nonobjective Areas	18
5. Supply Factors—Buildup	18
6. Game Forms	24
7. Estimated Form Requirements	25
8. Supply Management Assignments	29
9. Troop Unit and Population Assignments	30
10. Facility Category Assignments	66
11. Checklist for Phased Facility Requirements	66
12. Workload Categories	69

Problem

To develop a methodology for use in war gaming to evaluate the adequacy of theater stock levels.

Facts

The logistic feasibility of war plans can depend critically on supply availability in and outside the theater of operations. Adequacy of such supplies depends on the supply levels maintained, the time-phased theater consumption, and the capability of air and sea fleets to move additional supplies from their source to the area to be supported. Although Army stock levels, expressed in days of supply, have been established for specific areas of the world, these levels require review in the light of changing world conditions. Accordingly the DCSLOG instructed his Director of Plans to evaluate, through the use of military war games, the adequacy of stock levels under possible conflict situations in different world areas.

Responsibility for conducting the games that employed this methodology was given to ESSG of the Office, Chief of Engineers. The Logistic Simulation Division of RAC has participated in two DCSLOG games to date. It provided an observer and computer assistance in the first game, begun in October 1962. Prior to completion of this game DCSLOG requested that RAC develop the game methodology for the second theater to be studied. Besides developing and distributing the methodology and associated game forms for the second exercise the Logistic Simulation Division published the methodology for general distribution and provided computer assistance and guidance in implementing the methodology during the game. In addition the division prepared the game's scenario and administrative-support plan because of their critical dependence on the game design.

In games of this type both the nature of the desired results and time and manpower availability dictate the specific game design. The results have to be quantitative, be supported by careful documentation, and reflect a critical examination of the logistic support problem.

The methodology described in this report has been successfully applied to determine the adequacy of stock levels for DCSLOG. In addition the game methodology has been adapted and successfully used for development of force requirements for specified military operations.

SUMMARY

Discussion

The methodology describes a game that proceeds through pregame preparation, game play, and postgame activity. Gaming is accomplished by following a prescribed series of activities including the determination of (a) support-troop requirements, (b) supply-tonnage requirements, (c) facility requirements, and (d) transportation capabilities and requirements.

Game play is accomplished in an open one-sided game by a group of skilled military planners who represent selected planning capabilities (tactical operations, medical, engineer, ordnance, signal, quartermaster, transportation, etc.). The game is open in the sense that all results are made available to all players; it is one-sided in the sense that only Blue forces are played during the exercise. Enemy capabilities and activities are reflected in a campaign plan (scenario), which is developed prior to the game and provides a detailed statement of the phased deployment of combat forces, combat operations, combat phase lines, combat losses, and destruction of facilities.

Game Parameters

Examples of the degrees of approximation and aggregation used in this methodology are a scenario divided into time periods of equal length, throughout each of which combat operations are assumed to continue at a constant intensity; a theater of operations divided into an objective area and nonobjective areas*; an objective area subdivided into regions throughout each of which operations are assumed to be uniform; deployed forces divided into categories of supply user reflecting nationality, mission, and combat activity so that each user can be assumed to consume supplies at a constant rate in proportion to population; and supplies subdivided by class.

Computer Assistance

A computer program designed specifically for this game is used to compute supply tonnage (consumption and buildup) by class, user, region, and time period. Basic inputs of the program are populations by user, region, and time period and supply factors by user and class of supply.

Game Forms

Players are required to complete 15 different forms during game play. The use of each form is explained in this memorandum with instructions for its phased introduction into the game.

*The objective area is defined here as the geographic area of conflict, i.e., the area of primary concern because US and Allied forces directly confront enemy forces. The nonobjective areas are defined as all land areas between CONUS and the objective area that may affect the solution of the theater problem as either a source or consumer of forces and supplies, or both.

Game Organization

Responsibility for accomplishing the logistics game is assigned to a game Director. A Controller acts as executive officer to ensure that the game is conducted in accordance with the methodology. He provides the direction and review necessary to meet the game schedule and objectives. Players are provided by the Army Staff. They have responsibilities related to their normal staff functions as well as general responsibilities, e.g., completing forms, reviewing guidance, advising the Controller, etc. Certain players are assigned as supply managers for the various classes of supply. The unit play is assigned to specific players in accordance again with normal staff functions.

Game Schedule

Although each game may require separate scheduling to reflect a particular deadline, personnel commitments, or emphasis, this methodology suggests a 3-month schedule, 1 month each for pregame preparation, game play, and postgame activity.

Game Facilities

Game conduct requires about 2800 sq ft of office space furnished with desks, chairs, tables, files, and normal office equipment. Administrative-staff typing, reproduction, and publication; maintenance of a classified library; and access to a computer facility of the IBM 7040 or 7090 capacity are also necessary.

Pregame Preparation

Activities preceding actual game play involve preparation of basic guidance documents, assembly of documents containing plans, assembly of intelligence data, graphic display of the regions for each combat phase, assembly or development of necessary planning data (estimation of troop requirements), troop-list preparation, and organization for game conduct. The basic documents to be written, reviewed, and published are the scenario and the administrative- (logistic-) support plan and any required revisions of the game methodology. Principal planning data to be developed include supply factors, damage factors, and casualty rates. Intelligence data include facility inventories and statements of current assets. Key players together with the Director, Controller, and technical advisers are involved in drafting, reviewing, and publishing all pregame guidance and acquiring necessary data. All pregame documents are carefully coordinated to ensure compatibility of guidance.

Game Play

Players are called to a kickoff briefing by the Director. This briefing signals the completion of pregame preparation and the initiation of game play.

SUMMARY

Following the methodology and successive guidance in verbal or written controller messages, the players proceed through a series of steps in which individual study assignments are completed and the results submitted to the Controller for review and coordination with other players. Player assignments may be general or special. General actions are those to be done by all players, e.g., filling out Form 2, Troop List. Special assignments are those peculiar to one or a few players, e.g., analysis of sealift capabilities by the TC player. General and special assignments are identified in this memorandum.

Game play progresses through two major phases: an intertheater phase and an intratheater phase. During the first phase primary effort is expended in determining the consumption of supplies by the forces. Most of the actual computations are accomplished using the supply-tonnage-requirements computer program. Next, airlift and sealift capabilities are determined and compared with requirements for moving tonnages and forces. The effects of transportation restraints on theater stock levels are quantified, and the supply-tonnage requirements entering the objective area are determined. Phase 2 follows the determination of tonnages entering the objective area. During the second phase the players analyze in detail the logistic feasibility of supporting the combat forces in the objective area.

Should logistic support of the combat troops in the objective area prove infeasible, game guidance and/or assumptions may be revised. The play would also be recycled to establish both new supply requirements and new support-troop requirements and to determine the feasibility of the logistic-support capability under the changed parameters. The specific sequence of major game steps is:

- (1) Review starting troop list and allocate support units to geographic area of deployment.
- (2) Express unit and miscellaneous forces in terms of populations by user, region, and time period.
- (3) Determine gross consumption and buildup tonnages required by time period, class of supply, user, and region.
- (4) Determine air and sealift capabilities for moving supplies to replace consumption and to build up theater reserves.
- (5) Perform stock-level analysis by determining net tonnages by class to be moved to the objective area, i.e., balancing theater assets against gross requirements, considering transportation restraints and Army supply policy.
- (6) Analyze capabilities to support the campaign logistically in the objective area, e.g., ports, beaches, lines of communication, depots, base facilities, and airfields.
- (7) Recompute support-troop requirements based on workloads, i.e., modify stock-level analysis to reflect results of the objective area analysis.
- (8) Develop conclusions and recommendations concerning the adequacy of stock levels, the logistic feasibility of supporting the campaign, and support-troop requirements.
- (9) Revise game guidance and/or assumptions and recycle the game if supporting the game logistically appears infeasible.

Postgame Activity

Following the completion of game play two major tasks remain for the participants. The first is the preparation and publication of the game's reports; the second, final game administration, i.e., disposal of working papers, return of documents, clearance of players, and general reorganization for and return to normal activities. The game report includes several major sections:

- (1) Statement of the problem.
- (2) Background data.
- (3) Assumptions.
- (4) Facts.
- (5) Summary of game play and results.
- (6) Discussion of game play including summary of the methodology employed.
- (7) Conclusions drawn from the discussion.
- (8) Recommendations concerning implementation or follow-up of conclusions.
- (9) Annexes containing detailed data developed during the game play by individual players.
- (10) Annexes containing technical data and the game methodology.
- (11) Annexes containing game guidance: the scenario, the administrative-support plan, game directives, and Controller messages.

The game's final report is drafted, reviewed, published, and distributed, and the game is ended with its participants returning to their former staff assignments.

Conclusions

1. The game methodology as described has been used successfully to evaluate the adequacy of US stock levels in the Far East. In this case the game description, forms, and operational procedures met the requirements of the game's Director, Controller, and players.

2. This methodology has also been successfully adapted for use in solving other Army problems such as the determination of support-force requirements.

Recommendation

1. It is recommended that this memorandum be used by the Army as an operational manual for gaming the adequacy of stock levels.

**A Methodology
for War Gaming the Adequacy
of Theater Stock Levels**

ABBREVIATIONS

ACSI	Assistant Chief of Staff for Intelligence
ADSEC	advance section
AMC	Army Materiel Command
AMEDS	Army Medical Service
BASEC	base section
CA	civil affairs
CE	Corps of Engineers
CMLC	Chemical Corps
COMMZ	communications zone
CONUS	Continental United States
DA	Department of the Army
DCSLOG	Deputy Chief of Staff for Logistics
DCSOPS	Deputy Chief of Staff for Military Operations
DCSPER	Deputy Chief of Staff for Personnel
DUKW	amphibious truck, 2½-ton cargo
ESSG	Engineer Special Studies Group
LCM	landing craft, mechanized
LCU	landing craft, utility
LOC	lines of communication
LogOps	logistics operations
MC	Medical Corps
MT	measurement ton
OPLAN	operations plan
OrdCorps	Ordnance Corps
PIO	public information officer
PMG	Provost Marshal General
POL	petroleum, oils, and lubricants
PWs	prisoners of war
QMC	Quartermaster Corps
SigC	Signal Corps
SOP	standing operating procedure
ST	short ton
TacOps	tactical operations
TAG	The Adjutant General
TC	Transportation Corps
TE	task element
TOE	tables of organization and equipment

Chapter 1

INTRODUCTION

ORGANIZATION

This memorandum is divided into five chapters. Chapter 1 discusses the purpose of the methodology and illustrates its application by providing the game play parameters of a specific exercise. Computer assistance, flow of game activities, and form flow are explained. Chapter 2 provides a general description of organization for game play, i.e., participants, their responsibilities, game schedule, and game facilities. Pregame preparation is covered in Chap. 3, which describes actions required for the successful initiation of game play. Chapter 4 consists of a step-by-step description of the game play from the kickoff briefing to, but not including, the final review immediately preceding the preparation of the required final report. During the game play many forms are required for the preparation and presentation of data including computer inputs and outputs; these forms are introduced and explained with the appropriate game-step descriptions. Final postgame activities are reported in Chap. 5. These include the preparation and publication of the final report as well as the accomplishment of several administrative details.

Appendixes A and B provide, respectively, a sample tactical scenario and a sample administrative-support plan to supplement the discussion in this memorandum and to provide a guide for the preparation of these papers for future games. In addition to the outline of tactical events usually incorporated in a tactical scenario, App A includes logistics decisions and actions that could properly be taken by the commander concerned. Logistic decisions and actions that should be taken at a lower level are included in the administrative-support plan.

PURPOSE

The purpose of this memorandum is to present a methodology that was developed by RAC at the request of DCSLOG for use in a war-gaming exercise conducted primarily to determine the adequacy of Far East theater stock levels as now constituted under current Army policies and regulations.

BACKGROUND

The logistic feasibility of war plans can depend critically on the supply availability in and outside the theater of operations. Adequacy of such supplies depends on the supply levels maintained, the time-phased theater consumption, and the capability of the air and sea fleets to move additional supplies from their source to the area to be supported. Although Army stock levels, expressed in days of supply, have been established for specific areas of the world, these levels require review in the light of changing world conditions. Accordingly DCSLOG instructed his Director of Plans to evaluate, through the use of military war games, the adequacy of stock levels in the Far East under possible conflict situations in two different areas.

Responsibility for conducting the games was given to ESSG of the Office of Chief of Engineers. The Logistic Simulation Division of RAC participated in both games. In the first game, begun in October 1962 and completed in March 1963, the division provided an observer and computer assistance. Prior to completion of this game DCSLOG requested that RAC develop a game methodology for use in the second theater to be studied. Besides developing and distributing the methodology and associated game forms for the second exercise, the Logistic Simulation Division published the methodology for general distribution and provided computer assistance and guidance in implementing the methodology during the game. In addition the division prepared the game's scenario and administrative-support plan because the guidance in these papers had to be compatible with the game design.

Desired results and the time and manpower available dictate the specific game design. Results had to be quantitative, be supported by careful documentation, and reflect a critical examination of the total logistic-support problem. Moreover the form of the results of this second game had to be compatible with that of the first. Two months was available for development of the methodology, scenario, and administrative-support plan and for the acquisition of essential game information. Another 2 months was allocated for conduct of the exercise, game review, and preparation of the game's final reports.

The game methodology described in this memorandum takes full advantage of previous work accomplished for the Army by RAC's Logistic Simulation Division. Essentially this methodology is the same as that successfully used in the second DCSLOG game to determine the adequacy of currently established stock levels in a specific theater of operations. However, certain material has necessarily been deleted for security reasons; and generalizations have also been required to permit the methodology's use in a variety of problem contexts. Not only were the requirements of the Director, Controller, and players adequately met in these two exercises by use of the methodology described here, but the results obtained through its use are currently providing guidance for the establishment of new Army stock-level policies. Thus both the methodology and the results of its use have been validated by Army applications. In addition the methodology has been adapted by RAC to assist in the solution of other Army logistic problems. For example, a minor modification of the methodology was developed for use and successfully employed in two games for the Assistant Chief of Staff for Force Development (ACSFOR). The purpose of these games

was to develop force requirements for possible military operations; the RAC methodology was used to determine the support forces required in these operations.

SCOPE

Although the methodology described here was designed for and used in a logistics game for a specific area, it is generally applicable to similar games in other geographic areas. A step-by-step method for conducting a one-sided game is provided, not only for analysis of theater stock levels but also for analyses of support-troop, supply-tonnage, and facility requirements. Intertheater and intratheater transportation capabilities and requirements are also considered. Adaptations of this methodology have been used by the Army in development of support-force requirements. The game is designed for play within a predetermined time limit by a group skilled in military planning. Access to a computer (an IBM 7090 was used in the DCSLOG exercise) is desirable since the game employs a computer program to compute theater supply-tonnage requirements.

The exercise progresses through pregame, game, and postgame activities as shown in Fig. 1. Game phases consist of (a) intertheater analysis, in which the movement of troops and supplies (tonnages) to the theater of operations is analyzed to determine the adequacy with which the theater requirements can be met, and (b) intratheater analysis, in which outputs of the first phase, i.e., theater inputs of troops and tonnages, are used to analyze the feasibility of logistically supporting the assumed tactical operation in the objective area.

The intertheater and intratheater analyses are accomplished through the successive steps of estimation, computation, and modification. In the estimation step, combat troops, in the numbers available in each time period under the operations plan (OPLAN), are deployed in accordance with the scenario. The technical service troops available under the OPLAN are deployed, however, only in estimated numbers. During the computation step the computer determines supply-tonnage requirements for the deployed combat and technical-service troops. The troop lists and supply-tonnage requirements are then changed during the modification step to reflect increases in troops and tonnages required for facility and other workloads. The game play may then be recycled to achieve the game's required objective, i.e., the optimum practical employment of manpower, supplies, and facilities.

GAME-PLAY PARAMETERS

To accomplish game play, decisions must be made concerning:

- (a) Length of real time to be considered and its division into shorter periods for study.
- (b) Geographic partitioning of the objective area being studied.
- (c) Forces and populations to be played.
- (d) Supply categories to be evaluated.
- (e) Recycling of game play.

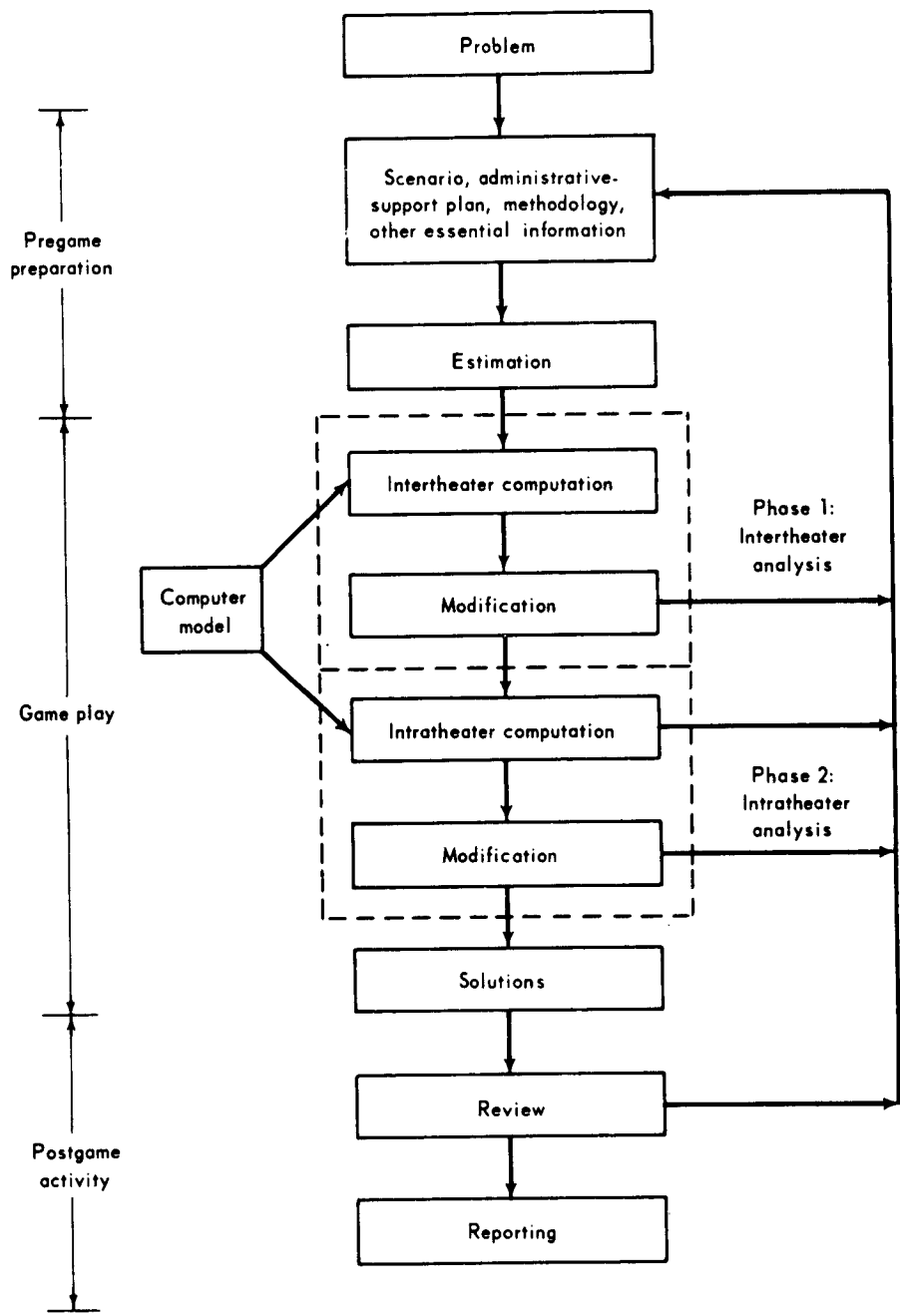

Fig. 1—General Game Flow Chart

Time Periods

The methodology assumes that tactical operations will be so presented on a time-phased framework that the type of action taking place in each time period in each region can be considered uniform throughout that time period.

TABLE 1
Time Periods, Second DCSLOG Game

Period	Duration	Period	Duration
1	D-20 to D-11	7	D+40 to D+49
2	D-10 to D-1	8	D+50 to D+59
3	D to D+9	9	D+60 to D+69
4	D+10 to D+19	10	D+70 to D+79
5	D+20 to D+29	11	D+80 to D+89
6	D+30 to D+39		

For example, the scenario of the second DCSLOG game covered a period of 110 days—20 days preceding D-day (the day the war is assumed to start) and 90 days including and following D-day. This was judged sufficient to cover any period in which a critical situation might arise because of inadequate initial supply levels or support-troop deployment. As shown in Table 1 the 110 days was divided into 11 10-day periods of play. In a subsequent game 210 days was studied in seven 30-day periods. As long as the length of calendar time to be played is defined, a decision can be made on the number of time periods and their length.

Geographic Parameters

To evaluate the adequacy of stock levels in a particular overseas theater of operations, the following must be determined:

- (a) Quantity of military stocks on hand in the theater of operations at the beginning of play.
- (b) Procurability of supplies from intratheater sources during play.
- (c) Availability of transportation to move supplies and forces into the theater.
- (d) Availability of movable supplies and forces outside the theater.

To address both the intertheater and intratheater aspects of the problem, the methodology provides for recognition of the following geographic areas, if desired:

- (a) CONUS, the primary source of forces and supplies, with no restriction imposed on supply availability at the ports of embarkation.
- (b) Intertheater or nonobjective areas, all land areas between CONUS and the theater of operations that may affect the solution of the theater problem as either a source of forces and supplies, a consumer of forces and supplies, or both.
- (c) Intratheater area or objective area, the geographic area of conflict and the area of primary concern by virtue of the fact that US and allied forces directly confront enemy forces.

The objective area may be divided into geographic regions to represent the type of activity likely to occur—combat, with degree of intensity, or logistical—and to locate consumers of supplies in sufficient detail to provide the basis for an adequate transportation analysis. Each player locates his forces and supplies in these designated regions. For example, in the second DCSLOG game, the objective area was subdivided into 11 regions: six corps areas, two

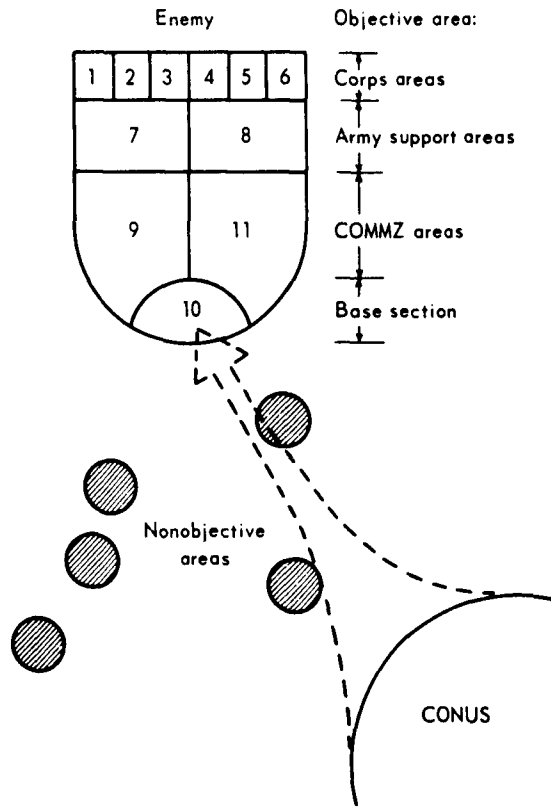

Fig. 2—Sample Theater Organization

army support areas, two COMMZ areas, and one base section area. Figure 2 is a schematic diagram of the geographic parameters used in the second game. The objective area can be divided into any number of geographic regions, although little would be gained by greatly exceeding the type of division illustrated.

Supply Parameters

Supply in both the objective area and the nonobjective areas may be studied in two major categories: replacement of consumption and accompanying buildup.

Theater Assets. Military supply assets on hand in all regions are determined from inventory data and/or Army regulations, specifically AR 11-12.¹ Game supply assumptions for nonobjective areas are different from those for the objective area. In nonobjective areas supplies consumed are assumed to be replaced on a continuous basis and no additional buildup of supplies is com-

puted; the assets on hand do not decrease or are not "drawn down on balance." Both consumption and buildup computations are necessary, however, in the objective area because of a need to draw down or use assets on hand and because of a logistic assumption that the level of supplies on hand is to be built up as troops arrive to a specific level in days of supply.

Consumption. Consumers of military supplies in both the objective area and the nonobjective areas are categorized into major groups representing types of user; each group consumes certain supplies at given constant rates differing from those of other groups. In the nonobjective areas it is assumed that two user categories, US Army and USAF, will be considered in determining consumption. Users in the objective area may be quite clearly designated.

A typical list might be:

- (1) US Army corps in intense combat.
- (2) US Army corps in normal combat.
- (3) US Army corps in reduced combat.
- (4) US Army corps in reserve.
- (5) US Army in the COMMZ.
- (6) USAF.
- (7) Indigenous army corps in intense combat.
- (8) Indigenous army corps in normal combat.
- (9) Indigenous army corps in reduced combat.
- (10) Indigenous army corps in reserve.
- (11) Indigenous army in the COMMZ.
- (12) Indigenous security forces.
- (13) Indigenous air force.
- (14) Indigenous paramilitary forces.
- (15) Prisoners of war (PWs).
- (16) Refugees.
- (17) Mobile civilian labor.
- (18) Static civilian labor.

If more than one indigenous army and air force were present, users 7 to 14 might be repeated as 19 to 26, for example. Users and their coding must be determined prior to game play. Maps and tabulations showing the entire theater population in appropriate regions and user categories are also required for game play. For each time period the maps show boundaries of the geographic regions and major unit command posts so that signal equipment requirements may be determined. Since consumption rates vary with combat activity, intensity of combat activity is indicated for those regions with military forces. Four degrees of combat intensity are considered: intense, normal, reduced, and reserve.

Buildup. No buildup is computed for nonobjective areas. Consumption is replaced, but all transportation above that requirement and the requirement for troop movements is devoted to the objective area. To facilitate computation of buildup, those forces authorized to receive buildup are identified by a buildup (auxiliary) code. A typical list might be:

- (1) US Army.
- (2) US Air Force.
- (3) Indigenous army.
- (4) Indigenous air force.

Classes of Supply. The methodology provides instructions for evaluating the adequacy of stock levels for up to eight classes of supply as well as initial equipment by time period in each nonobjective area and by region and time period in the objective area. Stock levels by class of supply, region, and time period in the objective area are further broken down by major user category listed. Standard military classes of supply that may be analyzed are shown in Table 2.

TABLE 2
Classes of Supply

Class	Explanation
Initial equipment	As called for by TOE
I	Food
II and IV less construction	Nonorganizational equipment and supplies, including special issue and spare parts but excluding construction materials
III bulk ^a	Petroleum products handled in bulk via tankers, pipelines, tank cars, and tank trucks (excluding Air Force)
III(A)	Petroleum products for the Air Force
IV construction	Construction materials
V	Ammunition (excluding Air Force)
V(A)	Ammunition for the Air Force

^aMay also include solid fuels such as coal.

Supply-Factor Units. All supply factors used in the game except those for class III bulk are expressed in pounds per man per day; class III bulk factors are expressed in barrels per man per day for ground operations and in gallons per aircraft sortie for air operations.

Supply-Consumption Factors. Evaluation of stock levels at any time requires definitions of stocks on hand, stocks consumed, and replacement stocks. A supply inventory will indicate the stocks on hand. Consumption is determined by computing the supplies, by class, used by the forces in the theater during each period. Each type of user consumes supplies at a different but constant rate. In order to provide for the variation in rates of consumption by army corps engaged in varying intensities of operations, army corps engaged in four different intensities of operation are considered different users. Each user category consumes one or more classes of supply. Table 3 is an example of the relations that must be established between the user categories and the classes of supply each may consume. In the example the US Air Force consumes every class shown in the columnar headings; refugees, only class I. Next consider the US corps categories. A US corps in intense combat may consume certain supplies at a rate different from its consumption rate in normal combat. A prerequisite for this game is the determination for the objective area of the consumption factors represented in Table 3 by "x" entries. If more or other user categories must be considered, the listing in the left column would be different. Table 4 is a similar example showing (again by appropriate x entries) the factors required for computation of supply consumption in the nonobjective areas. The factors actually used in a game should be provided in the administrative-support plan.

Supply-Buildup Factors (Theater Reserve Levels). Since buildup factors represent average rates of consumption for the duration of active operations in the scenario, fewer user categories are considered for buildup computations. Thus all user categories representing the US Army (US corps, intense; US corps, normal; etc.) fall into one buildup category—US Army, whose consumption is stated in terms of combat rates. Table 5 illustrates four buildup user categories—US Army, US Air Force, indigenous army, and indigenous air force—and the factors associated with them. An x entry indicates a requirement to provide a buildup factor for that class of supply in order to reflect the particular user's buildup requirements. The factors actually used in a game should be provided in the administrative-support plan.

Game Cycling

The methodology provides for recycling the entire game or any of its parts. This flexibility is required because of the type of analysis employed, i.e., successive steps of estimation, computation, and modification. In this type of analysis, if the Controller decides that results are not adequate at a particular time, he may direct changes in assumptions or modification of other inputs and recycling of that part of the game affected. The scenario is written with a fixed phasing of major tactical troop units and combat activity; logistic assumptions are predetermined in the administrative-support plan. If the use of certain assumptions or other inputs leads to an area of infeasibility, a change in these assumptions or inputs with a corresponding change in the game play or replay of the involved game activity, which this methodology makes possible, may result in a better solution and will probably preclude the necessity for a complete game recycling at the end of the first cycle.

Parameter Summary

To summarize, this methodology provides for consideration of:

- (a) Multiple time periods each of fixed duration.
- (b) Three major types of geographic area—CONUS, the intertheater area or nonobjective areas, and the intratheater or objective area broken into regions.
- (c) Supply-user categories for supply-consumption and supply-buildup computations in the objective area, and user categories for supply-consumption computations in the nonobjective areas, there being no supply buildup in these areas.
- (d) Up to eight classes of supply as well as initial equipment for the computation of supply consumption and buildup.
- (e) Recycling as required of all or part of the game play.

Application of these parameters in the second DCSLOG game to analyze supply in the objective area is illustrated in Fig. 3, which shows schematically:

- (1) Consideration of 11 geographic regions for each of 11 time periods.
- (2) Deployment of troops in each region by appropriate user category.
- (3) Multiplication of troop populations for the user category region, and time period combinations by appropriate supply factors to determine consumption and buildup for the various supply classes, users, regions, and time periods.

Figure 4, which is similar to Fig. 3, portrays the parameters used in the same game for the nonobjective area supply analyses. These parameters include 11 time periods, 5 geographic regions (one for each nonobjective area),

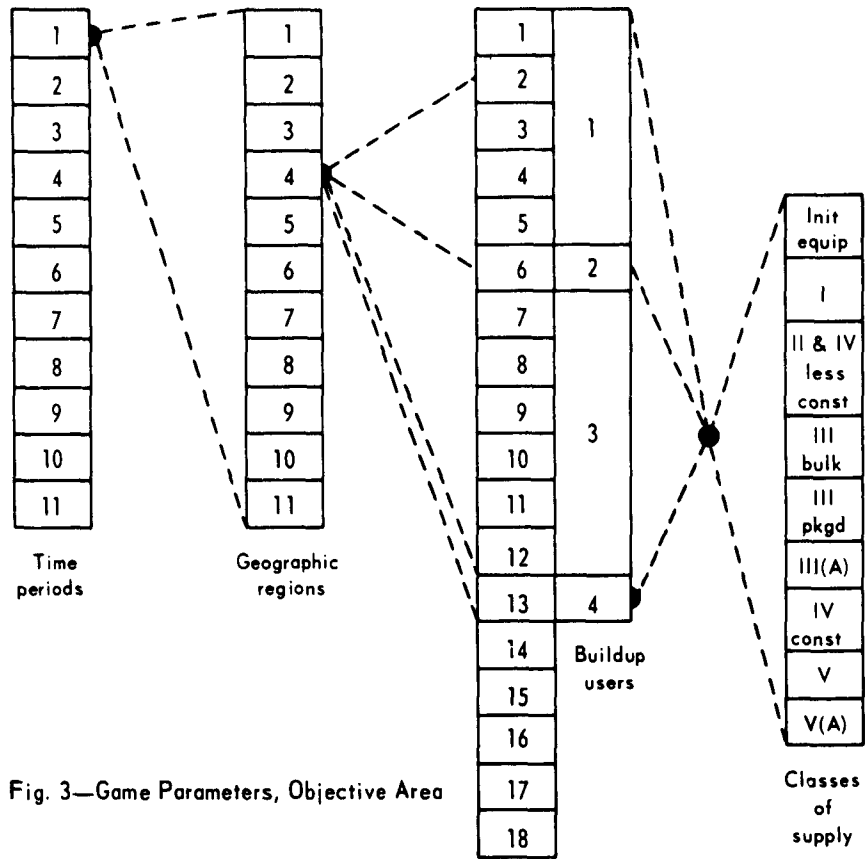

Fig. 3—Game Parameters, Objective Area

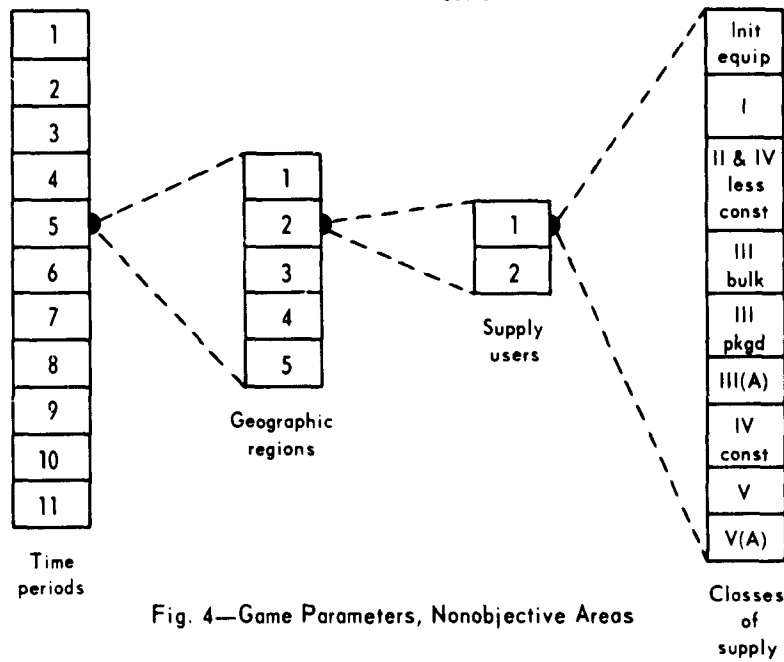

Fig. 4—Game Parameters, Nonobjective Areas

2 supply users (US Army and USAF), and the same 8 classes of supply plus initial equipment. Populations for the nonobjective areas are developed from troop lists and listed by user categories for each time period and location. They are then multiplied by the appropriate supply factors to determine consumption for the various supply classes, users, regions, and time periods.

COMPUTER ASSISTANCE

Purpose

The volume of computations required for the determination of supply-tonnage requirements necessitates computer assistance. Accordingly a computer program, called the "dry cargo" program during the DCSLOG exercises, was designed to supplement the game methodology (see Fig. 5). Additional computer programs were used in the subsequent games for ACSFOR.

Program Input

Input to the program consists of consumption and buildup factors and population data. Consumption and buildup factors are estimated requirements in pounds per man per day for each class of supply consumed or needed to establish a specified buildup level. These factors vary by user category and are initially provided in the administrative-support plan. The population input consists of a listing, for each time period and each region, of the cumulative and incremental populations for all user categories. These listings are developed from the troop lists provided with the scenario.

Program Output

The program produces for each time period a report showing daily supply-tonnage requirements, both consumption and buildup, by class of supply for each user in each region. Requirements for all classes of supply except class III bulk are totaled for each user, and requirements for all users in each region and all users in all regions are totaled for each class of supply.

GAME FLOW AND FORM REQUIREMENTS

Game Flow

Gaming is accomplished by following the specified series of pregame, game, and postgame steps that are shown in the detailed flow chart presented in Fig. 6. These steps are discussed in Chap. 3, "Pregame Preparation"; Chap. 4, "Game Play", and Chap. 5, "Postgame Activity."

Game Forms

The methodology includes a series of forms designed to be completed by the participants so that the game results are provided in a uniform, timely, and adequate manner. Forms may be revised for use in a specific game depending on the game parameters to be considered. A total of 15 forms is used

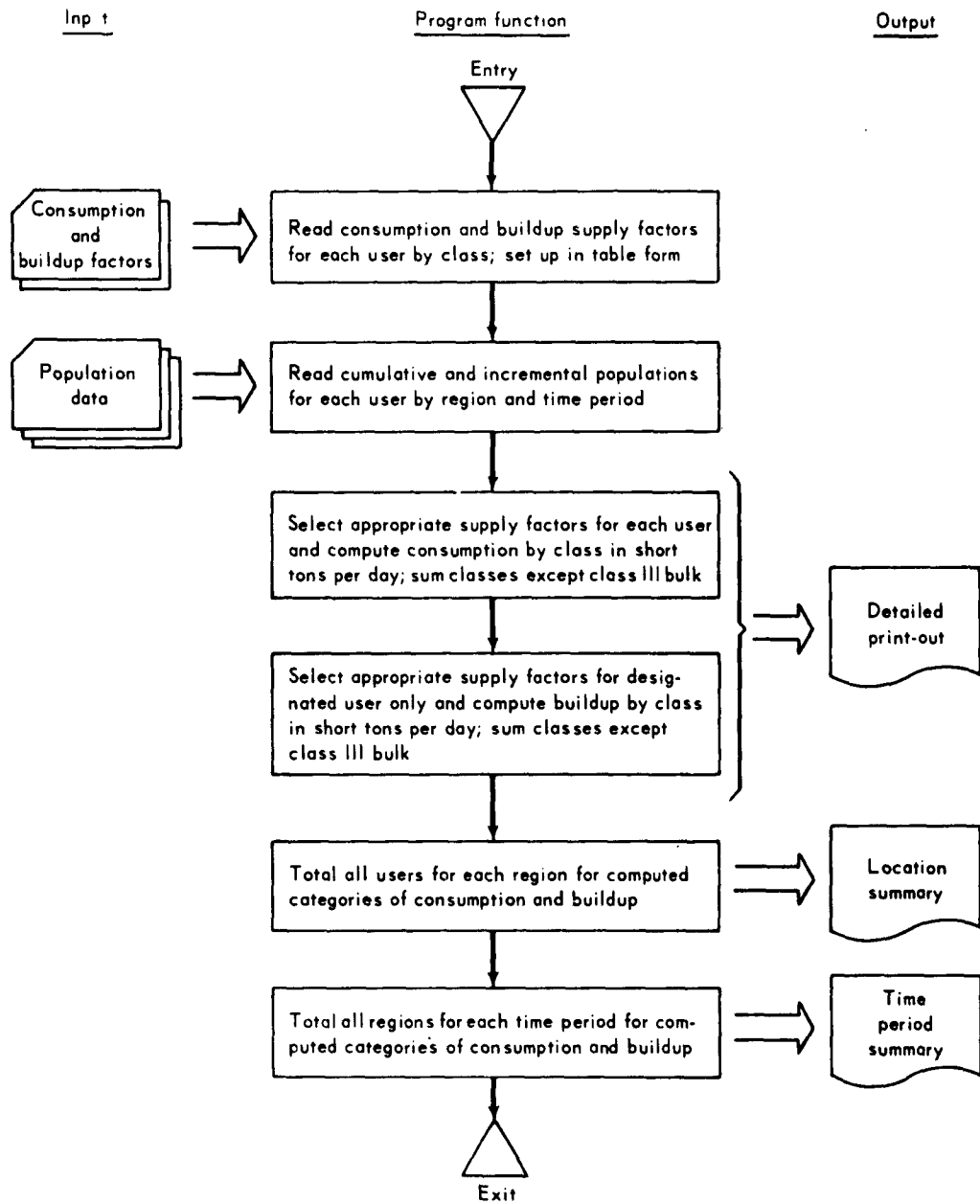

Fig. 5—General Flow Chart for Supply-Tonnage Requirements Program
 Totals are for each class of supply and for all classes combined except class III bulk.

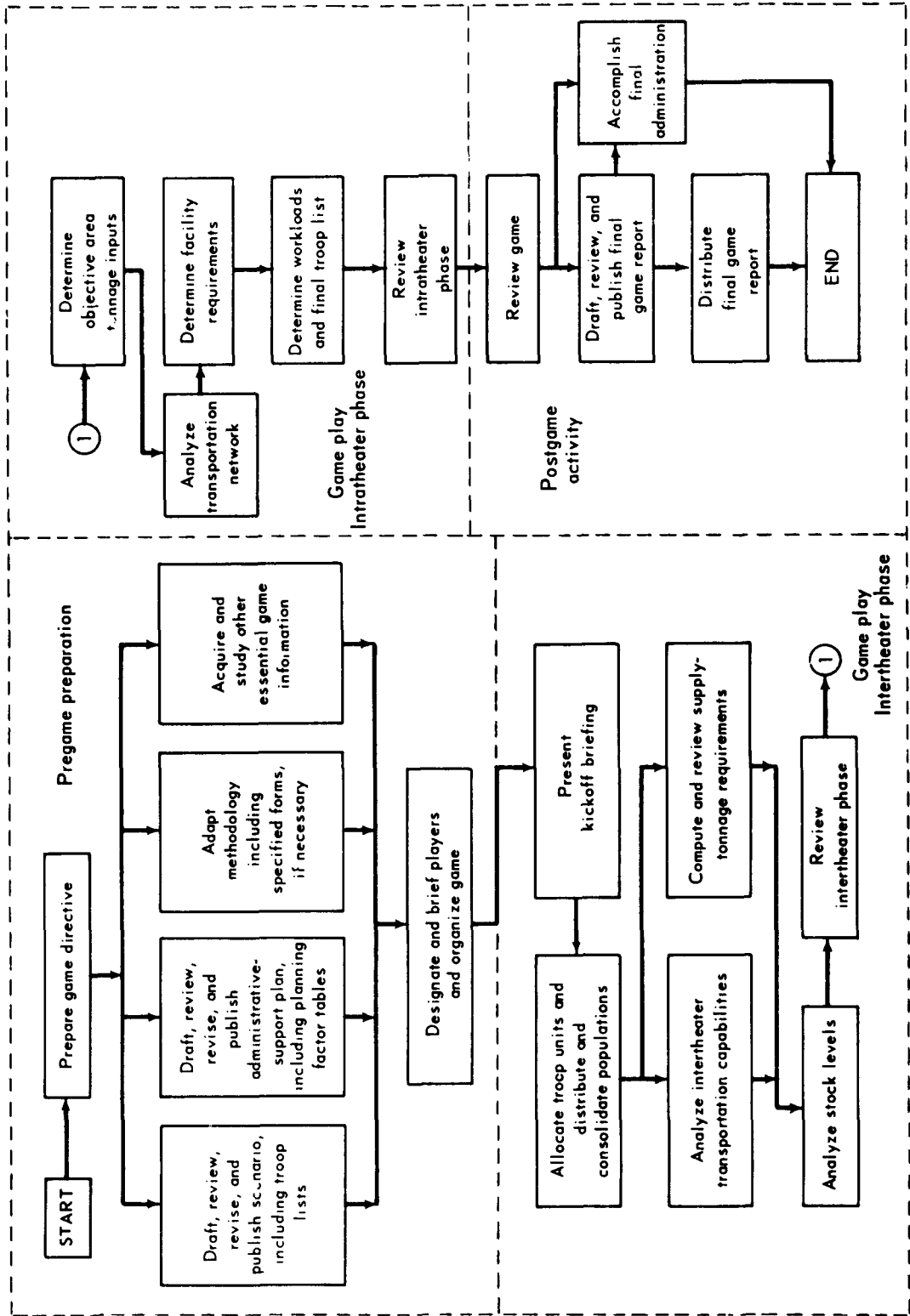

Fig. 6—Detailed Game Flow Chart

TABLE 6
Game Forms

Form number	Title	Purpose
1	Planning Factors	Initial consumption and buildup factors are provided in the administrative-support plan. The players use Form 1 to submit these factors and any changes in them to the Controller for his approval prior to their use as one of the two inputs (the other being populations) for the computer program's computation of supply-tonnage requirements.
2	Troop List	Initial phased troop lists are provided in the scenario. The players use Form 2 to submit troop list changes to the Controller for his approval.
3	Population by User by Region	Each player completes this form for each time period to report the cumulative and incremental populations of the units and nonmilitary categories he is playing (see Table 9). The DCSPER player and the Controller complete this form for the nonobjective areas. Most of the populations are derived from the troops listed on Form 2.
4	Population by Player by Region, Controller Worksheet	The Controller completes this form for each time period, as an interim step for the completion of Form 5, to consolidate the populations provided on Form 3 by user category and region to populations by player and region.
5	Population by User by Region, Controller Summary	One of these forms is completed by the Controller for each time period to summarize the populations derived by user category and region from Form 4.
5a	Computer Input: Population Data	Computer assistance personnel use this form to enter the populations provided on Form 5 in a format suitable for keypunching as one of the two computer inputs for the supply-tonnage requirements program.
6	Computer Output: Supply-Tonnage Requirements Report ^a	The computer program produces one of these forms or reports for each time period to show the daily supply-tonnage requirements, both consumption and buildup, by class of supply for each user category in each region. Requirements for all classes of supply except class III bulk are totaled for each user, and requirements for all users in each region and all users in all regions are totaled for each class of supply.
7a	Supply Voucher	Each change in supply status (consumption, receipts, transfers, etc.) is first described by the Controller on this voucher or form prior to posting of the transaction on a supply ledger for use in a stock-level analysis.
7b	Supply Ledger Sheet	One of these ledger sheets or forms is completed by the Controller for each location in order to provide a running account of each class of supply by time period and region.
8	Theater Bulk POL Tonnage Report	The POL player manually computes and enters on this form, one of which he completes for each time period, the requirements by region and user category for Air Force air operations. This report is used together with Form 6 and the TC players' manual computations of initial equipment and accompanying supplies for US Forces in the objective area and class V(A) for all areas to provide a total estimate of theater supply tonnage requirements.

TABLE 6 (continued)

Form number	Title	Purpose
10	Computation of Authorized Theater Reserves	This form is used by the players as a worksheet for estimating the authorized theater assets on hand by class of supply at the beginning of the game.
11	Distribution of Transportation Workload	The TC players submit one of these forms for each time period to the Controller to show the intertheater transportation workloads, both air and seairlift, by areas of origin and destination, class of supply, and transportation modes. The workload entries are derived from the vouchers completed during the stock-level analysis.
12	Objective Area Incoming Tonnage Report	This report or form is used by the TC players to list, by class of supply, time period, and transportation mode, sea or air, the tonnages entering the objective area. These tonnages are derived from Form 11.
13	Objective Area LOC Movement	The TC players use this form to record the tonnages to be moved by the various railroad and highway links they have selected.
14	Phased Facility Requirements	One of these forms is completed for each time period by all players to list their objective area requirements for facilities that are to be provided by the CE.

^aDuring the second DCSLOG game this form was called the "Dry Cargo Tonnage Report."

TABLE 7
Estimated Form Requirements

Form number	Quantity required	Form number	Quantity required
1	20	8	20
2	100	10	20
3	200	11	2
4	200	12	20
5	15	13	100
5a	200	14	50
7a	150		
7b	20		

to accomplish game play. These forms are listed in Table 6 with a brief statement of each form's use. A more complete description appears in the discussion of the game play when the use of the form is introduced.

Form Flow

Various forms are required to be completed at predetermined steps in the game play. Figure 7 shows the sequence and flow of forms throughout the exercise and identifies the major category of game participant using each form, i.e., player, Controller, or computer support.

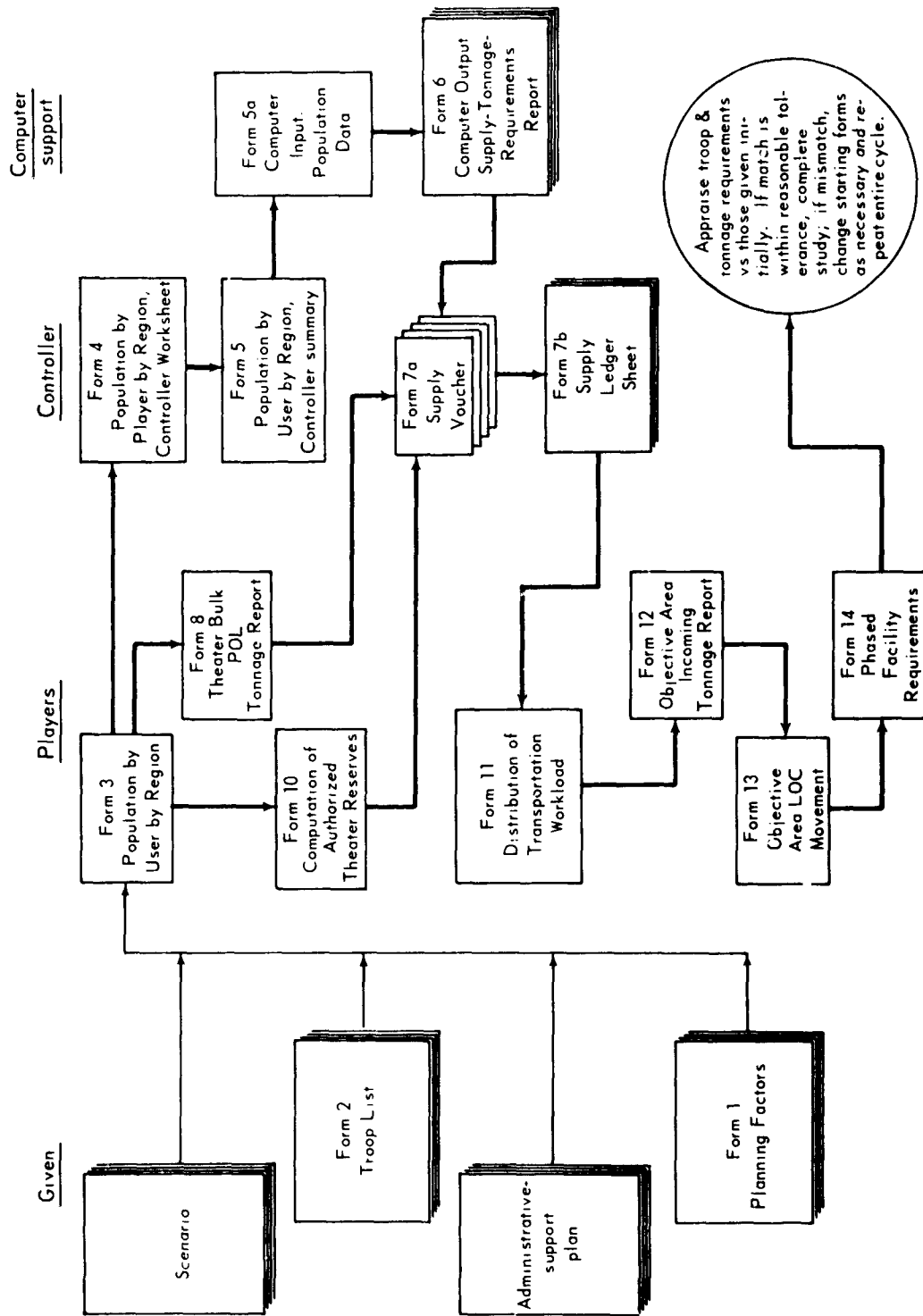

Fig.7—Form Flow Chart

Estimated Form Requirements

An adequate supply of game forms must be provided before game play can begin. Table 7 shows the estimated quantity of each form needed in a game with parameters similar to those in the DCSLOG game. Computer output forms are excluded. These estimates include only the original of each completed form. If the Controller or the Director requires carbon copies, additional blank forms should be provided.

Chapter 2

GAME ORGANIZATION

GENERAL

The implementation of this methodology requires an organization consisting of a Director, a Controller, technical and administrative support personnel, and a group of players. Figure 8 shows a typical game organization. Of course overall responsibility for the game's execution is assigned to the Director. The responsibilities of the Controller and the players are described in the following paragraphs.

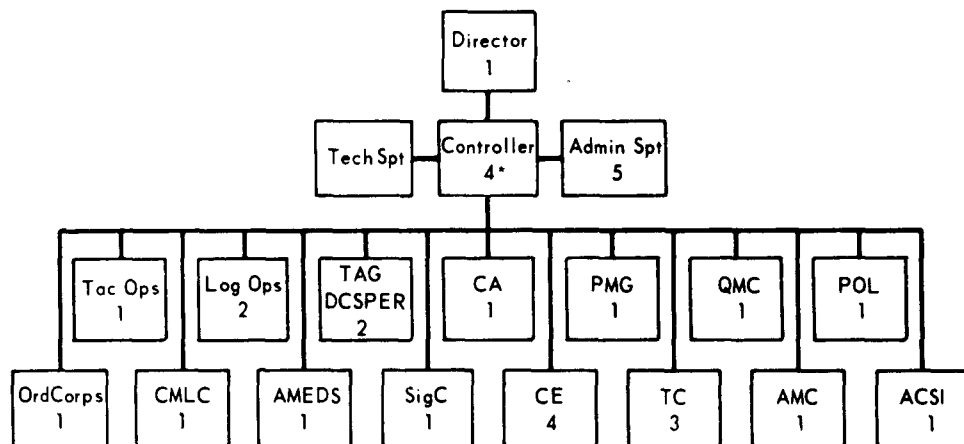

Fig. 8—Game Organization

*One Controller and up to three assistants.

CONTROLLER RESPONSIBILITIES

The Controller ensures that the game is scheduled and organized; he conducts the game in accordance with the methodology, making sure the players have the direction and the time necessary for game play. He also reviews the progress of the play as it proceeds, renders required decisions following the players' presentation of findings or problems, coordinates results between players, and discusses results with the Director.

PLAYERS AND PLAYER RESPONSIBILITIES

Players

Players for the game are provided by the Army Staff; thirty-two were in the DCSLOG game. Generally they are responsible for functions of the Army organizational component that they represent and for additional assignments made in the methodology or by the Controller. Players representing DA general staff agencies provide guidance primarily for policy decisions, and players representing DA administrative and support services develop factors for logistic computations and perform functions related to planning considerations.

Player Responsibilities

Each player performs the following general and specific tasks in accordance with game emphasis and player availability:

TABLE 8
Supply Management Assignments

Class of supply	Managing player
Initial equipment	TC
I	QMC
II and IV less construction	Log Ops
III	POL
IV construction	CE
V	OrdCorps
V(A)	TC

- (1) Manages classes of supplies listed in Table 8.
- (2) Plays units and population categories assigned in Table 9.
- (3) Accomplishes specific tasks listed after Table 9.
- (4) Completes and submits the forms required by the methodology to the Controller.
- (5) Provides data within his area of responsibility and accomplishes necessary coordination with other players, e.g., the TC player coordinates his selection of the LOC network with the CE and POL players.
- (6) Determines and submits to the DCSLOG player significant requirements for PWs and indigenous personnel to support his operations.
- (7) Determines and submits class IV tonnage requirements through the Controller to the TC players.
- (8) Determines and submits facility and construction requirements to the CE players.
- (9) Contributes a draft writeup of his functions and findings for the final game report.

DCSOPS. The DCSOPS player plays all combat and combat support forces including allied and indigenous air defense, Air Force, and Marine except US Army combat support engineer and signal units, which are played by the CE and SigC players. This play includes the location of major combat elements,

DCSPER. The DCSPER player furnishes intra- and intertheater personnel-movement requirements for replacements and losses. This information is made available through the Controller to the TC player.

TAG. The TAG player advises the TC player of the mail tonnage to be moved.

CA. The CA player determines the availability of indigenous labor to support military forces (DCSLOG uses this information to allocate support to the other players) and the total numbers of refugees and requirements for support of indigenous civilian population including refugees. The CA player together with the PMG player establishes controls over civilian activity in the vicinity of military installations and LOCs.

PMG. The PMG player establishes the number of PWs, civilian internees, and military prisoners available to support the military forces; the number of these individuals to be supported by the AMEDS player, and evacuation requirements for these individuals from the objective area. He receives estimates from ACSI of PWs and internees to be incarcerated, requirements from TC for LOC security and traffic control, the number from AMEDS of fixed-bed hospitals, and the numbers from CA and DCSLOG of refugees and critical installations requiring MP control.

QMC and POL. The QMC player advises the Controller concerning modification of class I factors, and both he and the POL player advise the TC player of transportation requirements for class III. The QMC player is advised by the PMG player concerning PWs and civilian internees to be supported, by the CA player concerning civilian support requirements, and by the AMEDS player concerning field hospitals to be supported.

OrdCorps. The OrdCorps player modifies class V factors as necessary and advises the Controller of recommended changes. He is advised by the CE and CMLC players of their requirements for ordnance class IV items and tonnage.

CMLC. The CMLC player determines requirements for chemical class V and advises the OrdCorps player.

AMEDS. The AMEDS player determines medical-support requirements, based on troop population and its dispersion, environmental factors, and combat intensity. As input for these calculations he requires estimates from the MP player of PW and civilian internee populations and estimates from the CA player of indigenous civilian and displaced-person populations to be supported. He furnishes medical-supply consumption factors to the class II manager and appropriate extracts of his hospital unit list to the MP, QMC, and CE players as input for their requirements calculations. In addition he advises the CE player of hospital construction standards desired in the theater.

SigC. Based on guidance provided in the scenario concerning location of command units and tactical phasing, the SigC player determines communication requirements, signal troops, and class IV materiel requirements. He coordinates communication requirements for the control of pipeline operations with the POL player.

CE. The CE player determines construction workloads and class IV construction-material requirements based on the stated facility requirements of the other players, his own analysis, construction requirements stated in the administrative-support plan, and combat task support required in the combat zone.

TC. The TC player is primarily responsible for evaluating tonnage-movement requirements based on reports produced by the computer and the other players. He receives requirements from the DCSPER player for the movement of replacements in the objective area and the nonobjective areas, requirements from the TAG player for the movement of mail, and requirements from all players through the Controller for the movement of supply tonnages. He determines total airlift and sealift capabilities and requirements in the objective area and the nonobjective areas, LOC capabilities and requirements within the objective area, LOC security and traffic control requirements for use by the PMG player, and TC class IV tonnage requirements.

AMC. All questions concerning materiel availability in CONUS, including the time required for movement from depots to ports, are referred to the AMC player.

ACSI. The ACSI player is the primary contact for all game participants requiring intelligence information. Included in the major intelligence he provides is an estimate required initially by the PMG player of the number of PWs and civilian internees to be incarcerated. To supplement guidance provided in the administrative-support plan the ACSI player also provides the TC and CE players with estimates of enemy capabilities for inflicting damage on logistic-support facilities. In addition he provides information concerning US intelligence and counterintelligence units.

GAME SCHEDULE

Each application of this methodology will result in the establishment of a unique schedule. The sequence of activities will be the one presented here, but the time schedule may fluctuate considerably because of varying deadlines, personnel commitments, and emphasis. It is suggested that 3 months be allocated for each game, including pregame preparation, game play, and preparation and publication of the final game report. A suggested game schedule is presented in Fig. 9 for guidance.

GAME FACILITIES

Principal facilities required for the conduct and support of a game include (a) a desk or working table for each player; (b) a classified map and chart room for permanent displays; (c) a Top Secret document storage vault; (d) space for briefings, conferences, and layout work; (e) computer facilities and personnel, including keypunching; and (f) stenographic, reproduction, and graphic support facilities and personnel.

Excluding computer, reproduction, and graphic support facilities, a floor area of approximately 2800 sq ft is required for conducting and supporting a game. The area of a typical game layout as shown in Fig. 10 is apportioned approximately as follows: (a) support-troop players, 1000 sq ft; (b) Director, Controller, and tactical operations and logistic groups including stenographic support, 1150 sq ft; (c) map and conference room, 450 sq ft; and (d) document storage and library, 200 sq ft.

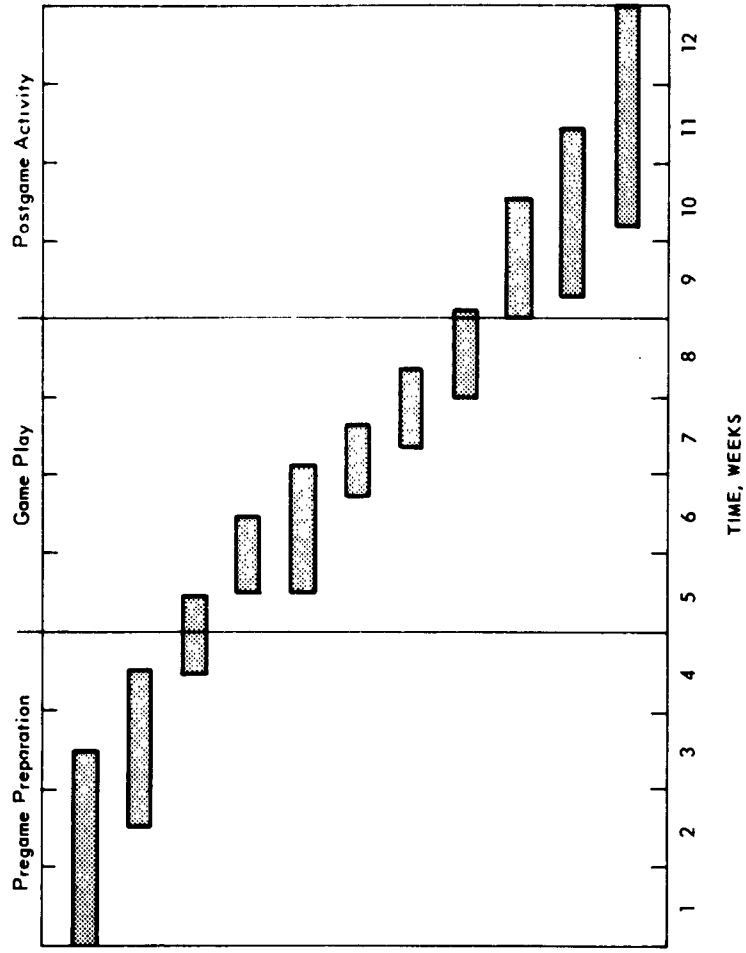

Fig. 9—Suggested Game Schedule

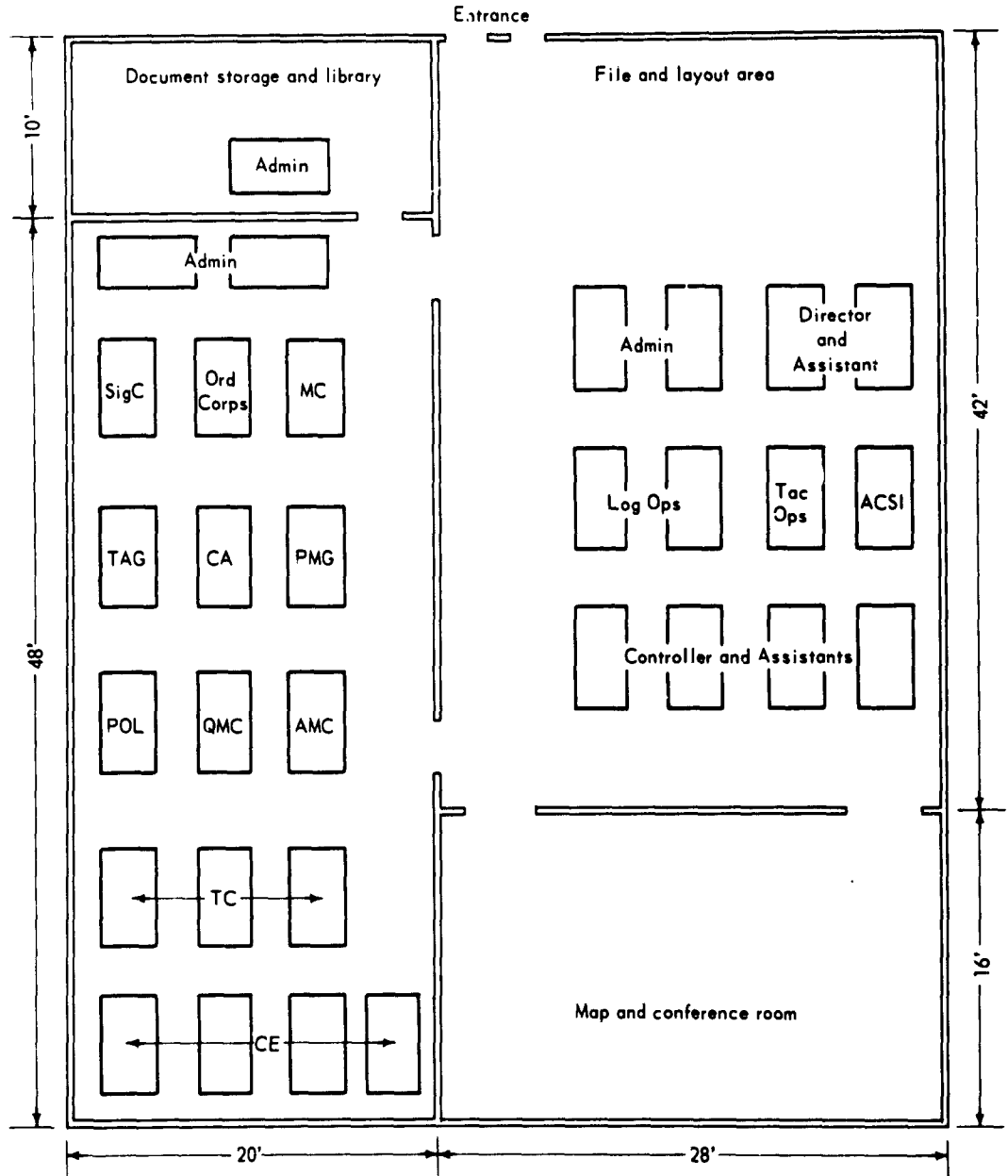

Fig. 10—Typical Game Floor Plan

Chapter 3

PREGAME PREPARATION

GENERAL

Certain pregame activities must be accomplished before actual game play can begin (see Fig. 11). The first action required is the preparation of a game directive by the game sponsor. This directive establishes the objectives of the project, assigns major responsibilities to the agencies concerned,

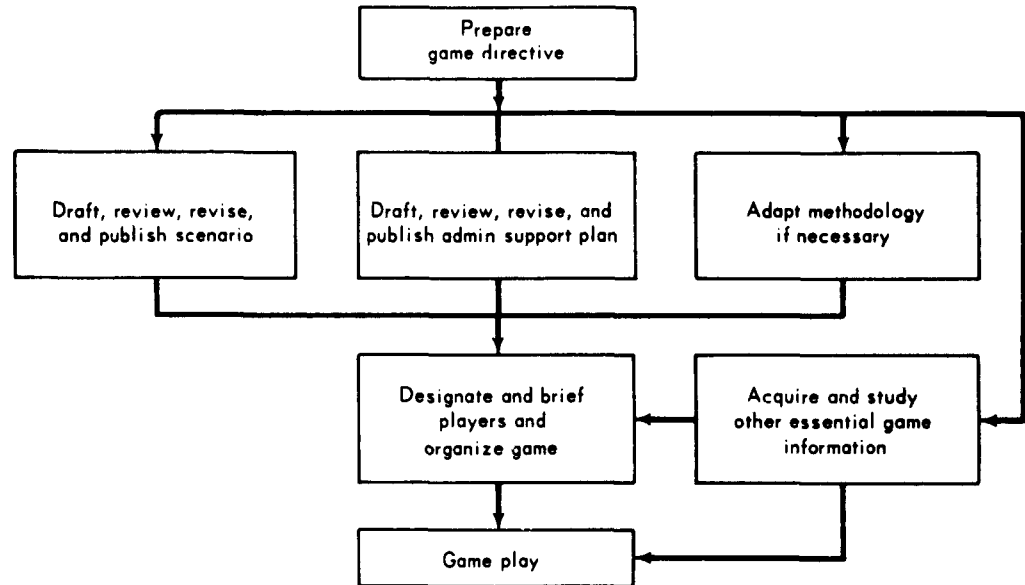

Fig. 11—Pregame Preparation Flow Chart

and fixes the desired kickoff and completion dates. Following receipt of the game directive the responsible agencies prepare the scenario, including initial troop lists, and the administrative-support plan, including supply factors for review, revision, and publication prior to the beginning of game play. This methodology including game forms may also need to be adapted. The preparation and adaptation of these papers must be carefully coordinated so that their information and guidance is compatible and adequate for conduct of the game.

During and immediately following the preparation, review, revision, adaptation, and publication of the guidance papers, other information essential to the conduct of the exercise is acquired and organization for the conduct of the game proceeds. This organization includes designation and briefing of players, preparation of administrative directives, establishment of the game schedule, and provision of pregame papers, publications, and forms to participants.

GUIDANCE PAPERS

Preparation of Scenario and Administrative-Support Plan

Scenario. A scenario is developed by DCSOPS on the basis of plans and information designated in the game directive. The scenario chronologically describes the assumed progress of the conflict including major Red and Blue deployments and movements. It also provides initial troop lists indicating phased deployment of Blue support-troop units into the objective area. Separate troop lists are prepared and printed on Form 2, "Troop List" (Fig. 12) for each tactical, technical, and administrative player and for each nationality and service involved in the game. Logistic and administrative players normally will submit their portions of the initial troop list on Form 2 (see Table 9). The initial combat support-troop requirements are usually factored from established force planning guides or extracted from applicable operations plans.

Certain considerations govern the development of the scenario. Principal considerations, which have been discussed in Chap. 1, include (a) total time covered by the scenario and its division into time periods, (b) geographic partitioning of the objective area, (c) categorization of forces and populations to be supported, (d) supply categories to be evaluated, and (e) availability of planning factors.

Administrative-Support Plan. Information and guidance that affects the logistics game and is necessary for the degree of detail to be considered is provided in the administrative-support plan written by DCSLOG and coordinated with game players. Included in the general types of information it contains are (a) logistic-support responsibilities of the US military services, (b) logistic organization of the theater, and (c) planning factors in pounds per man per day,* by class of supply and user, for consumption and buildup of reserve supplies. Players submit the factors to the Controller on Form 1, "Planning Factors," shown in Fig. 13.

Adaptation of Methodology

The methodology must be responsive to the problem presented in the game directive and should be adapted if necessary, so that guidance and forms for play properly recognize the specific geographic and time situation.

Review, Revision, and Publication of Scenario and Administrative-Support Plan

The game sponsor and other game personnel review the draft copies of the scenario and the administrative-support plan. Informal discussion of each

*Planning factors for bulk POI are barrels per man per day for ground operations and gallons per sortie for air operations.

FORM 1

PLANNING FACTORS

CYCLE: _____
 DATE: _____

*

USER	C L A S S						
	I	II & IV (less Const)	III (Pkg&)	III (Bulk)	IV (Const)	V	VA
US CORPS - INTENSE							
US CORPS - NORMAL							
US CORPS - REDUCED							
US CORPS - RESERVE							
US COMZ							
US AF							
INDIG CORPS - INTENSE							
INDIG CORPS - NORMAL							
INDIG CORPS - REDUCED							
INDIG CORPS - RESERVE							
INDIG COMZ							
INDIG SECURITY FORCES							
INDIG AF							
PARAMILITARY							
POW							
REFUGEES							
CIV LABOR - MOBILE							
CIV LABOR - STATIC							

*Enter "Consumption" or "Buildup"

Fig. 13—Form 1, Planning Factors

paper between game personnel and authors may be expected. Comments and recommendations for revisions are forwarded to the game sponsor by a predetermined date. The game sponsor then reviews all comments and recommendations, selects and integrates those he considers proper, and returns the draft papers to their authors for revision and publication.

OTHER ESSENTIAL INFORMATION

Other information essential to the conduct of the exercise must be acquired and studied in advance by the game sponsor and game personnel. Such information, which is updated and validated whenever possible during the game, consists primarily of the types of data and intelligence employed in developing and testing war plans and in preparing Department of the Army Strategic Logistic Studies. Among the types of information acquired are (a) Army regulations establishing supply levels; (b) relevant operational plans of higher headquarters providing the composition, date of arrival, and tonnage of equipment accompanying reinforcements as well as planning factors, doctrine, concepts of support, and policies; (c) relevant base development plans showing military construction currently in process and/or planned; (d) mobilization plans for indigenous forces; (e) TOEs for all units in the objective area; (f) class IV projects for which equipment and supplies have been stockpiled for use in the objective area; and (g) CA studies.

PLAYER DESIGNATION AND BRIEFING AND GAME ORGANIZATION

Designation and Briefing of Players

Following receipt of the game directive the game Director requests the various agencies to designate their game representatives. On the designation of these representatives and approval of the game's revised guidance papers; i.e., the scenario and administrative-support plan, the Controller calls the agency representatives together for an orientation briefing concerning guidance provided in these papers.

Preparation of Administrative Directives

Prior to the beginning of game play the Controller prepares several administrative directives for distribution to participants. These directives provide an SOP for security of documents as well as administrative instructions and information for players concerning location of the game site, hours of duty, transportation schedules, parking facilities, identification badges, property passes, storage space for classified materials, and cafeteria and telephone facilities.

Establishment of Game Schedule

Another necessary pregame activity is the Director's preparation of a game schedule that programs the game's significant steps for completion by specific dates.

Provision of Pregame Papers, Publications, and Forms

Before game play commences the revised scenario and administrative-support plan, the methodology, and the administrative directives prepared by the Controller are reproduced and distributed in sufficient numbers for efficient player use. Selected pregame publications are assembled and distributed as individual player handouts, and all game forms are reproduced and stored at the game site.

Chapter 4

GAME PLAY

INITIATION OF PLAY

Following the successful completion of all major pregame activities actual game play is initiated. To accomplish the game play the players complete a series of forms under the Controller's continuous direction and guidance in the form of "Controller Messages" or informal verbal instructions.

The kickoff briefing both terminates the period of pregame preparation and signals the beginning of game play. This briefing, convened by the game's Director and attended by all game participants on the day scheduled for beginning game play, has the following purposes: (a) to report on pregame preparations not accomplished or reported at the time of the earlier player briefing concerning the scenario, administrative-support plan, and methodology; (b) to outline the schedule of play and specific player responsibilities; and (c) to inform game participants of administrative and security regulations, stenographic and library services, and the general availability and use of office facilities.

PHASES AND STEPS OF PLAY

Following the kickoff briefing the series of major activities portrayed in Fig. 14 commences. The play proceeds through two major phases, intertheater and intratheater. The intertheater phase consists of the analysis of requirements for the capabilities of moving men and materiel between the three major geographic entities—CONUS, the nonobjective areas, and the objective area. Following the resolution of the intertheater phase the play turns to the intratheater phase, the analysis of the feasibility of supporting the assumed tactical play within the objective area. This analysis requires consideration of support requirements vs capabilities of men, materiel, and facilities. Each step in both phases involves successively estimation, computation, and modification to achieve the required objective—the optimum practical employment of manpower, supplies, and facilities.

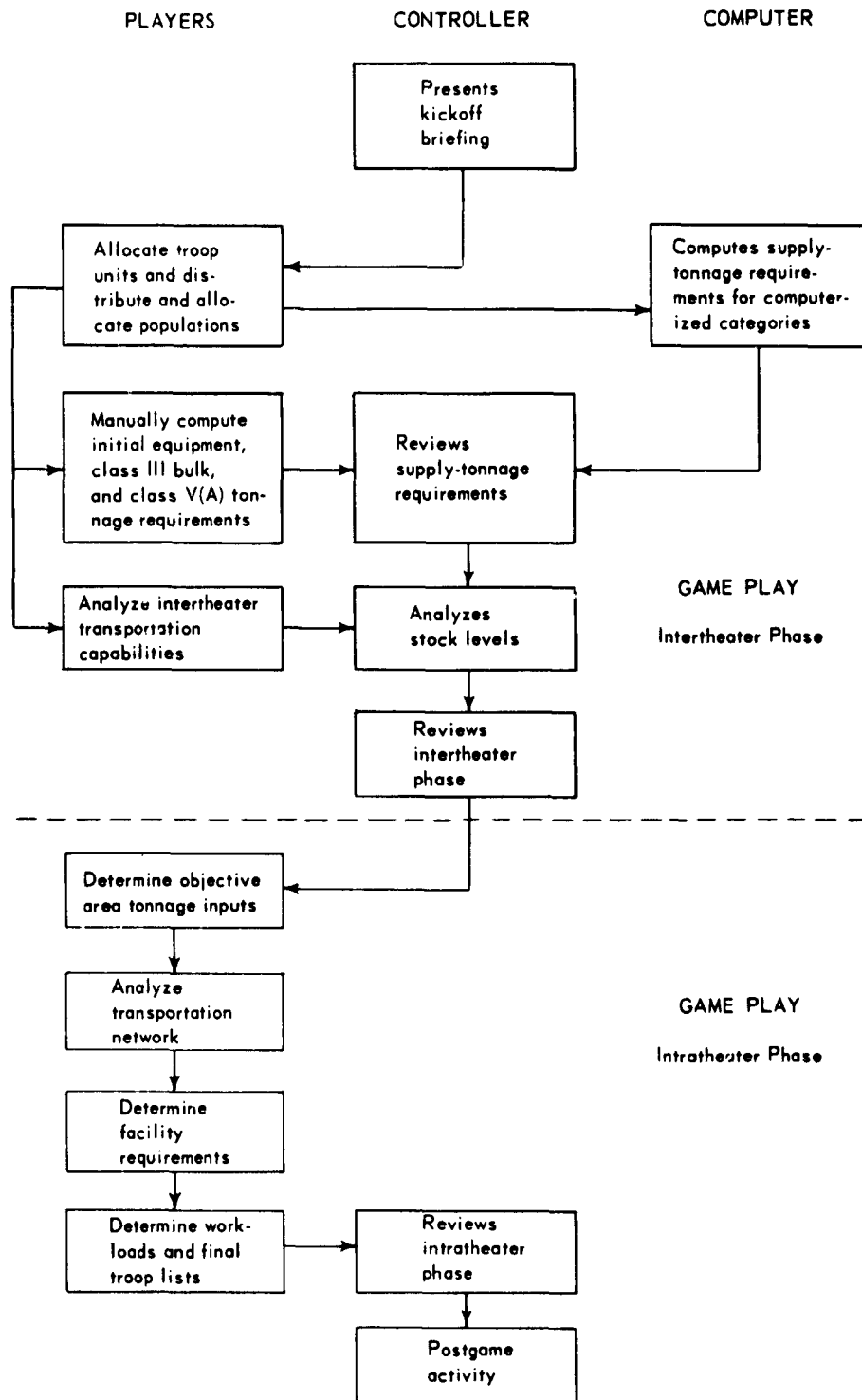

Fig. 14—Game Play Flow Chart

INTERTHEATER ANALYSIS*

Troop Unit Allocation and Population Distribution

The first tasks that confront each player charged with playing specific troop units and population categories (Table 9) are (a) detailed review of the phased troop list provided with the scenario; (b) modification of the troop list as required and submission of any changes together with justification to the Controller; (c) allocation of troop units and nonmilitary populations to the specific geographic regions in the objective area to or in which they are deployed or located; and (d) conversion of the units allocated by region to strengths by region.

Using the completed Form 2's provided with the scenario, each player deploys his units for each time period by region in the objective area; in each region he identifies each unit with a type of user category. The player then converts units and unit fractions to populations, multiplying the number of units by the unit strength. Both the incremental and cumulative populations for each time period are posted to Form 3, "Population by User by Region" (Fig. 15). Thus each player deploying troops completes 11, one Form 3 for each time period. In addition all players having responsibilities for providing estimates of nonmilitary populations, e.g., refugees, civilian labor, and civilian internees, also post these populations to their Form 3's; the DCSPER player and the Controller complete Form 3's for the nonobjective areas. On completion of their Form 3's the players submit them to the Controller for review and consolidation.

Figure 16 illustrates the mechanics a player employs in converting a phased troop list to a population distribution. This example assumes that the scenario calls for four combat battalions in the objective area during time period 2. The player determines that three of these battalions are to be located in region 2, and one in region 4. Having made this decision, he converts to strength by multiplying the number of units by the unit strength and enters the results appropriately on Form 3. The entry in region 2 of 619 opposite I (incremental) means that one of the three units was deployed to region 2 during time period 2.

Insofar as possible, each player resolves questions that may arise concerning troop lists. Any controversial questions or questions that the individual cannot resolve are brought to the Controller's attention. Generally this method of problem resolution is followed throughout the game.

Population Consolidation

Following the submission of all player Form 3's the Controller consolidates the populations by user category and region for each time period to populations by player and region on Form 4, "Population by Player by Region, Controller Worksheet" (Fig. 17). Each player's populations for his user categories are totaled and entered as a single line item on Form 4. For example (see Fig. 18), the Controller transfers the population distribution of the CE troops posted to user category US corps-normal 1857, from the CE Form 3 to the Controller's Form 4 for user US corps-normal in the row opposite CE. The columns of

*Examples and forms are those used in the second DCSLOG game.

FORM 2

TROOP LIST

TOE	NAME	STRENGTH	MODE	TIME PERIOD		
				1	2	3
5-35D	Combat Bn	619	S	3	4	(3)
5-48D	Supply Co	102	S	2	2	(1)
5-115D	Const Bn	893	S	4		
5-144D	Const Spt Co	164	S			
5-124D	Dump Truck Co	108				
5-129D	Fort Const Co					
5-167E	Topo Co					
5-177D						

(619) = 1857 (Region 2)
 (619) = 619 (Region 4)

FORM 3

USER	REGION	TIME PERIOD 2				POPULATION
		1	2	3	4	
US CORPS - Normal	C		1857			
US COMMZ	I		619			619

Fig. 16—Theater Population Determination

FORM 3

TIME PERIOD: 2

REGION	1	2	3	4
USER				
US Corps - Normal		1857		619
		619		

FORM 4

USER: US Corps - Normal

REGION	1	2
USER		
Engineer		1,857
		619
TOTAL		46,006
		37,140

FORM 5

TIME PERIOD 2

REGION	1	2	3
USER			
US Corps - Intense			46,026
US Corps - Normal			37,140
TOTAL			187,432
			102,210

Fig. 18—Population Consolidation

each Form 4 are next totaled to provide population by region for all players for each user in each time period. Totals are derived for both incremental and cumulative populations. In this process player troops lose their identity.

Next the Controller transfers the totals on the Form 4's to the appropriate row of Form 5, "Population by User by Location, Controller Summary" (Fig. 19), one of which is prepared for each time period. Form 5 is the basic reference tabulation used in preparing the computer input forms for the computation of supply-tonnage requirements; it also provides the Controller with a summary sheet to evaluate support-troop balance in each region and throughout the entire theater.

Supply-Tonnage-Requirements Computation

Computer Program. Most of the computation of supply-tonnage requirements is accomplished by the computer program described in Chap. 1. As stated there, inputs of the program include supply consumption and buildup factors (Form 1) and the theater population data (Form 5). Consumption and buildup factors for the objective and nonobjective areas are revised prior to the requirements computation, and the population input is transcribed by computer assistants from Form 5 to Form 5a, "Computer Input: Population Data" (Fig. 20). These data are also used as the basis for further analysis or re-analysis of support requirements. The program computes for each time period average daily supply-tonnage requirements, both consumption and buildup, by class of supply for each user category in each region. Classes of supply included in these computations are I, II, and IV (less construction), III bulk, III packaged, IV construction, and V. Class III(A), class V(A), and initial equipment and accompanying supplies are computed manually. Tonnages for consumption and buildup (there is no buildup for forces in the nonobjective areas) and for all supply classes except class III(A), class V(A), and initial equipment and accompanying supplies are listed by the computer on Form 6, "Computer Output: Supply-Tonnage-Requirements Report" (Fig. 21). One of these reports is produced for each time period to show the daily supply-tonnage requirements, both consumption and buildup, by class of supply for each user category in each location. Requirements are reported in short tons per day for all classes except class III bulk, which is reported in barrels per day and does not include AVGAS and jet fuel required for operation of Air Force aircraft. Each report totals not only requirements for all classes of supply except class III bulk for each user but also requirements for each class of supply for all users in each region and for all users in all regions.

POL and TC Players. The POL player manually computes and enters on Form 8, "Theater Bulk POL Tonnage Report" (Fig. 22), the class III (bulk) requirements by time period, user, and region for Air Force air operations; the TC player manually computes initial equipment and accompanying supplies for US Forces in the objective area as well as class V(A) for all areas.

Supply-Tonnage-Requirements Review

The methodology calls for concurrent submission to the Controller of Forms 6 and 8. On receipt of these reports the Controller reviews the tonnage requirements by time period; using experience and reports from similar studies

FORM 5a

COMPUTER INPUT: POPULATION DATA

The period Region
 1 2 3 4

User Code		User Title	Aux Code		Cumulative Population					Incremental Population						
5	6		7	8	9	10	11	12	13	14	15	16	17	18	19	20
	1	US CORPS-INTENSE		1												
	2	US CORPS-NORMAL		1												
	3	US CORPS-REDUCED		1												
	4	US CORPS-RESERVE		1												
	5	US COMZ		1												
	6	US AIR FORCE		2												
	7	INDIG CORPS-INTENSE		3												
	8	INDIG CORPS-NORMAL		3												
	9	INDIG CORPS-REDUCED		3												
1	0	INDIG CORPS-RESERVE		3												
1	1	INDIG COMZ		3												
1	2	INDIG SECURITY FORCES		3												
1	3	INDIG AIR FORCE		4												
1	4	INDIG PARAMILITARY														
1	5	POW														
1	6	REFUGEES														
1	7	CIVILIAN LABOR MOBILE														
1	8	CIVILIAN LABOR STATIC														

Fig. 20—Form 5a, Computer Input: Population Data

FORM 6 — Supply-Tonnage-Requirements Report

COMPUTER OUTPUT

THEATER TONNAGES FOR TIME PERIOD XX

PAGE NO. XX

	CONSUMPTION					BUILDUP								
	CLASSES OF SUPPLY					CLASSES OF SUPPLY								
	Cl 1	Cl 2 (-Const)	Cl 3 (Pkg)	Cl 4 (Const)	Cl 5	Total Dry	Cl 3 (Bulk)	Cl 1	Cl 2&4 (-Const)	Cl 3 (Pkg)	Cl 4 (Const)	Cl 5	Total Dry	Cl 5 (Bulk)
LOCN XX														
USER XX														
.														
.														
.														
TOTAL														
.														
.														
TOTAL														

Fig. 21—Form 6, Computer Output: Supply-Tonnage-Requirements Report

for guidance, he makes an initial evaluation concerning the magnitude of the tonnages. The purpose of this evaluation is to foresee possible problems involved in the forthcoming transportation and distribution analyses and to acquaint participating players with these problems so that they will approach the stock-level analysis with a better appreciation of the supply situation.

Intertheater Transportation Capabilities Analysis

While tonnage computations are being made, the TC player analyzes airlift and sealift capabilities* for all probable transportation links connecting CONUS, the nonobjective areas, and the objective area. He must have a relatively accurate estimate of transportation capabilities so that he can properly advise the Controller during the forthcoming stock-level analysis.

Airlift Capability. Numbers of aircraft used are based on the latest official estimate of available aircraft by type and ton-mile. The ton-mile capability of the projected fleet allocated for Army use is calculated by multiplying the capacity index (the allowable payload for the specific route multiplied by the block speed over that route) for each aircraft type by the number of aircraft in the inventory. Totals by type are then added to indicate fleet capacity in terms of ton-miles per day, and reductions are made for nonproductive ton-miles required to provide aircraft turnaround and route support. The result is the gross productive airlift capacity for the first month. After the first month, productive ton-mile capacity is further reduced to compensate for delayed maintenance and inspections; finally it is reduced to produce a net-productive-phased ton-mile airlift capability for Army use. The airfields in the objective and nonobjective areas represent a wide range in terms of logistic feasibility for use. In order to estimate the capacity of airfields for the game the TC player uses, to the maximum extent possible, the data available in current intelligence documents, principally "Airfields and Seaplane Stations of the World,"² which is revised constantly. Techniques developed in previous similar analyses and in The George Washington University Navy Logistics Research Project Study "Multi-Mode Transportation Network Analysis,"³ are used in the application and interpretation of this intelligence.

Sealift Capability. The TC player analyzes sealift by using not only planning data and results developed in previous similar analyses but also current projections of US-controlled ocean cargo-ship inventories for the area under study. For ease of analysis the inventory is expressed in terms of average-sized or "notional" ships assumed to have a general cargo capacity of 3870 st, requiring 5 days for loading and 5 days for discharge. The preliminary estimate of shipping availability relies on the game Controller's guidance, based on data provided in Forms 6 and 8, in predicting probable route or link workloads. With these preliminary tonnage estimates the TC player is able to assign available ships to routes on a priority or other predetermined basis in order to use shipping capability effectively. He develops the final shipping allocations as the stock-level analysis proceeds. Toward the end of the game he makes a final adjustment, if necessary, to reflect variations in tonnages resulting from the objective-area analysis.

*The POL player analyzes tanker capabilities to transport bulk POL.

Stock Level Analysis

Measurement of stock levels in any supply situation at any time requires a consideration of the following basic elements: assets on hand at the beginning of the period, consumption of assets during the period, and receipts of resupply during the period.

The starting asset position must be determined. This determination could be made by conducting a current inventory. However, in the gaming described here, the objective is to measure stock-level adequacy assuming that assets on hand are equal to reserves authorized in AR 11-12.¹ Additional theater assets include class IV projects in the theater.

Consumption during any period is the sum of the products of the user categories and their rates of consumption. In this methodology the consumption report is produced principally by the computer program on Form 6.

Receipts of resupply during the period depend on a combination of stocks available, their location, the transportation facilities available to move these stocks, and the time required for their movement. The transportation analysis accomplished by the TC player just prior to this stock-level analysis provides a preliminary judgment of the objective area capability to receive cargo, expressed in short tons per day. DCSLOG may then set any limits on tonnage input to the objective area. Stocks are assumed to be available in CONUS in unlimited quantity. Certain restraints, however, are placed on their immediate availability because of the time required to process the release of precut requisitions, move supplies from depots to ports or airfields, and load ships or aircraft.

In addition to CONUS resupply, other sources of resupply to be considered include local suppliers in the objective area and both military reserves and local civilian suppliers in the nonobjective areas.

Supply Accounting. To accomplish the stock-level analysis a ledger supply account is established for each class of supply in each geographic region considered in the stock-level analysis. Figure 23 depicts the procedure to be followed in this analysis. For each class of supply a supply account is established at the beginning of the game. This account shows the total assets on hand in short tons.* These assets consist of authorized reserves, operating stocks, safety levels, and class IV project stocks. Projected receipts from CONUS during each time period are estimated considering shipping and supply availability. Projected receipts from nonobjective areas are estimated considering shipping and supply availability plus planned disposition of these supplies. Next the supply account is decreased by the estimated consumption during the time period. This step-by-step process produces by the end of each time period (a) the asset status in short tons for each class of supply at each location and (b) a revised transportation estimate that reflects changes in initial shipping assumptions during the time period. At the end of each time period the asset status is converted from short tons to equivalent days of supply by dividing the short tons on hand by the short-ton equivalent of 1 day of buildup for each class of supply. These buildup tonnages have at this time already been determined by the computer program for all classes of supply except III bulk, III(A), V(A), and initial equipment. The days-of-supply statement is important

*Barrels for class III bulk.

because it is a simple measure of stock-level adequacy that can be used to compare days of supply on hand with minimum safe levels and with buildup objectives prescribed in current Army regulations. The stock-level analysis is a joint effort coordinated by the Controller with the advice and the assistance of the TC players and the supply managers. Each class of supply is managed separately, although the Controller keeps in mind the need for supply balance and efficient use of transportation. He is guided in his decisions by prescribed priorities assigned to the employment of transportation facilities as well as by statements of minimum acceptable supply levels and buildup levels to be achieved.

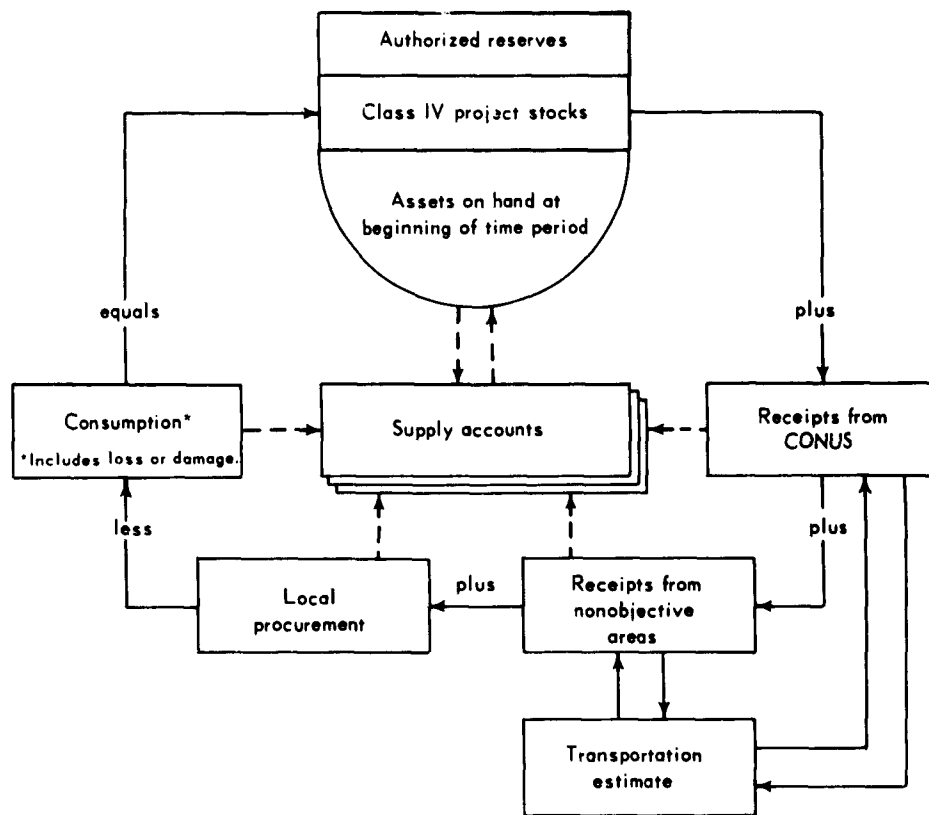

Fig. 23—Procedures for Stock-Level Analysis in Any Region

Assets on Hand. All players having class-of-supply assignments prepare status summaries of the stock assets in the objective and nonobjective areas by the time period, class of supply, and region. Management assignments were defined in Chap 2. These summaries are required by each player in order to adjust requirements to reflect the asset position by class of supply preparatory to accomplishing analyses of stock levels and intertheater lift. An analysis and summary is made of all potential assets in the objective area and nonobjective areas, including class IV project stocks, authorized theater reserves, and local procurement; and the effects of enemy action on stock are also analyzed and

summarized. Analysis of class IV projects determines their availability for use in the objective area and reveals time restrictions on their availability. The CE player manages operational projects dealing with construction even though supplies from several technical services are involved. Stocks of authorized theater reserves on hand are assumed to equal the authorized level in days of supply multiplied by the daily buildup factor and the initial population. (See the administrative-support plan for authorized days of supply and location of authorized theater reserves.) Each class-of-supply manager computes the assumed authorized levels using Form 10, "Computation of Authorized Theater Reserves" (Fig. 24), and analyzes the availability of supplies through local procurement in the theater. Local availability of items such as vehicles, food, and construction materials may be of great significance. Following guidance provided in the administrative-support plan the supply manager plays loss of supplies due to damage.

Transactions. During the stock-level analysis every action that quantitatively affects assets on hand is described on a supply voucher. An example of a completed supply voucher is shown in Fig. 25. This voucher, which records an assumed supply transaction (46th) in Cycle 1 of the game, shows that, during time period 4, forces in region 10 consumed 6242 ST of class V and received 4986 ST from CONUS.

CLASS OF SUPPLY <u>V</u>	Voucher No. <u>46</u>
Time Period <u>4</u>	Cycle <u>1</u>
Region <u>10</u>	
DESCRIPTION OF TRANSACTION:	
<i>Consumed 6,242 short tons</i>	
<i>Received 4,986 short tons (CONUS)</i>	
Form 7a	

Fig. 25—Form 7a, Supply Voucher, Example

At particular times during the stock-level analysis (usually following the analysis of a class of supply in a time period) all vouchers are used to post transactions to a supply ledger. A ledger sheet with columns for posting voucher entries is provided for each region studied. Assumed entries have been made on the sample ledger sheet shown in Fig. 26 in order to illustrate its use. These entries are taken from the example voucher shown in Fig. 25. First, the 32,417-3 entry is the balance (32,417ST) of class V in region 10 at the end of time period 3. The period 4 consumption (6242 ST) is posted from the voucher to the supply ledger sheet's debit column for class V, and the period 4 incoming tonnage (4986 ST) is posted from the voucher to the supply ledger sheet's credit column for class V. Finally the net balance at the end of time period 4 is 31,161 ST (32,417 + ~~286~~ - 242).
 $4986 - 6242$

The procedure described above is repeated for each class of supply in each region for each time period. The objective of this procedure is to provide information on which to base decisions that will tend to (a) maximize the tonnage moved using available transportation facilities, (b) maintain the supply stocks above the minimum level established initially, and (c) attain the objective buildup level within the time specified in the administrative-support plan.

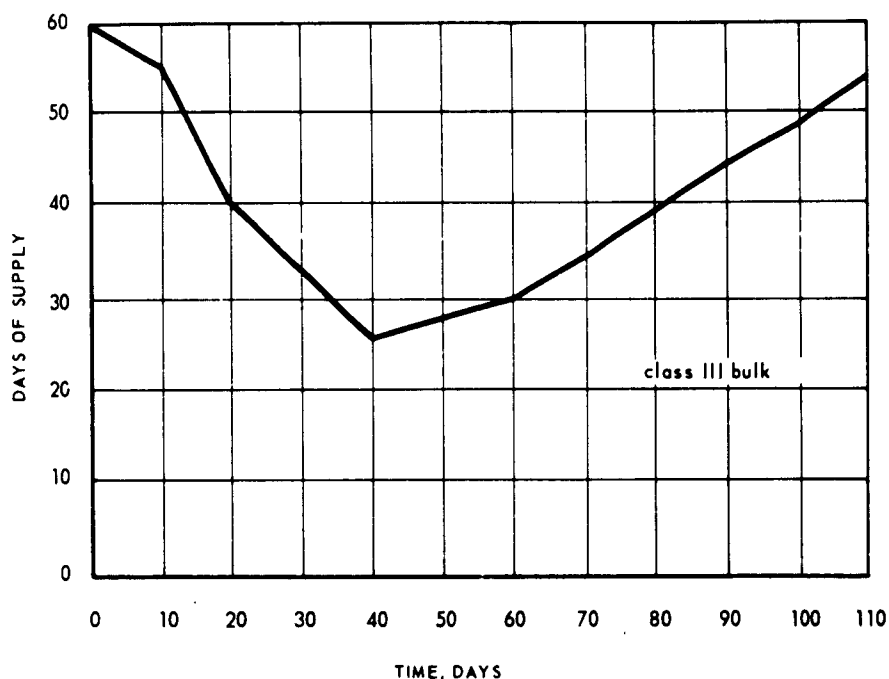

Fig. 27—Portrayal of Stock-Level Analysis Results

Graphic Portrayal. An example of a method for portraying the results of the stock-level analysis is shown in Fig. 27. This chart is an assumed plot of the class III bulk asset position expressed in days of supply on hand at the end of each 10-day period. The asset position is equivalent to 60 days of supply at the beginning of the game. As the game proceeds, this position drops on the fortieth day to a low of 26 days of supply. By this time transportation into the objective area is adequate for delivering more tonnage than the forces are using. Therefore the asset position begins to improve slowly.

A set of charts similar to Fig. 27 for each class of supply analyzed provides a comprehensive basis for the Controller and the Director to determine the adequacy of stock levels at any time in the game. Following the objective-area analysis a reevaluation of stock-level adequacy is made.

Transportation Workloads

The TC player uses Form 11, "Distribution of Transportation Workload" (Fig. 28) to record, for each time period, intertheater air- and sealift workloads by area or origin and destination, class of supply, and transportation mode. He

then submits them to the Controller. The workload entries are derived from vouchers completed during the stock-level analysis. For any given time period, the tonnage of a class of supply to be moved is entered in the requirements column opposite the class of supply for the appropriate destination area. The areas of origin for this tonnage, its distribution by area of origin, and mode of transportation employed are entered in the remaining columns. Form 11's use is shown in Fig. 28. Assume that the supply voucher (Form 7a) completed during the stock-level analysis indicates that 4800ST of class V is to be delivered to region 10 of the theater during time period 1. The source or sources of this tonnage will also be entered on Form 7a. In this example 3200 ST is arriving by sea from CONUS and 1600ST by sea from another area, here designated "area 2."

Intertheater Review

The analysis of lift capability vs the intertheater transportation workloads established in the game and the resultant measure of stock-level adequacy are reviewed, and a preliminary determination is made of the degree of intertheater feasibility. The review may reveal that individual players need to re-evaluate their assets-vs-requirements results and to revise their work accordingly. If an infeasibility results and the changes necessary to achieve feasibility can be accomplished, game play is recycled beginning with the appropriate step and terminated only when an acceptable degree of intertheater feasibility is achieved. If and when intertheater feasibility is achieved, the remainder of the game is played. When intertheater infeasibility occurs and no plausible recycling appears possible, the game may be terminated and the final game report prepared, reproduced, and submitted to the game sponsor. During the intertheater review very specific measures of stock-level adequacy will be available for examination. The succeeding phase of game play, the intratheater phase, may uncover problems so extensive and serious that the Controller and the Director may require adjustments in the stock-level analysis and its results or a complete replay of the game.

INTRATHEATER ANALYSIS*

Assuming that intratheater analysis has been satisfactory and that net tonnages to be moved to the theater have been established (Form 11), the TC player then completes Form 12, "Objective Area Incoming Tonnage Report" (Fig. 29). In this step incoming tonnages lose their identity as to areas of origin and are summarized for each time period by transportation mode (sea or air) and by class of supply. When Form 12 is completed, the TC player can begin his analyses and selection of ports, beaches, airfields, and LOCs.

Port, Beach, and Airfield Analysis and Selection

Relying on guidance provided in the scenario and the administrative-support plan and on intelligence data, the TC player considers ports, beaches,

*Examples and forms are those used in the second DCSLOG game.

and airfields available to receive the phased tonnages in the objective area. The ports, beaches, and airfields to be used in each time period are selected following an analysis of their adequacy for unloading, storing, and clearing. An analysis is made to determine requirements for transportation troop units and transportation port handling equipment. If any facility proves inadequate, the TC player consults with the CE player and together they arrive at a decision concerning possible construction support requirements.

LOC Selection and Workload Computation

Using the computer reports of tonnage requirements by region, which have been modified as required to account for the adjustments made in the stock-level analysis, the TC player next selects the necessary LOCs and establishes and records the tonnage movements by railroad and highway links on Form 13, "Objective Area LOC Movement" (Fig. 30). When confronted with problems related to guidance provided, e.g., damage or an excess of requirements over rated LOC capacities, the TC player consults with the CE player and the Controller as necessary to resolve the problems. The POL player advises the TC player concerning the bulk POL that needs to be moved by highway or railroad; and the TC, POL, and CE players together with the Controller, if necessary, perform a joint analysis to determine the best movement plan for bulk POL.

Facility Requirements Determination

Following the LOC selection and the computation of transportation workloads all players determine and list their gross facility requirements on Form 14, "Phased Facility Requirements" (Fig. 31). These requirements are stated in terms consistent with the Engineer Functional Components System (TM 5-301).⁴ Table 10 lists the major facility categories to be considered and the responsible player for each. Table 11 provides detailed guidance concerning the terminology to be used in completing Form 14.

Before the players submit their completed Form 14's, they discuss any controversial projects with the CE player and the Controller, if necessary. The players assist the CE player in netting out (subtracting) locally available facilities by providing any known information concerning facilities in existence or to be constructed. In many instances facility requirements will be fairly firm, e.g., TAC, PMG, and CA; in other instances the best estimate will have to be furnished and revisions may be necessary as the game progresses.

The CE player reviews all stated gross phased facility requirements and identifies locally available facilities and those to be provided in accordance with projects specified in the administrative-support plan. In making the construction analysis, damage assumptions provided in the administrative-support plan are applied and analyzed. After the initial analysis any major discrepancies between CE construction capability and stated player requirements are resolved by the CE player with the appropriate players and, if necessary, the Controller. As a result of their analysis the CE player determines his troop requirements and class IV construction material and equipment requirements.

FORM 13

OBJECTIVE AREA LOC MOVEMENT

CYCLE: _____
DATE: _____

LINK	CAPACITY FOR TIME PERIOD											
	1	2	3	4	5	6	7	8	9	10	11	

Fig. 30—Form 13, Objective Area LOC Movement

FOR: 14

PHASED FACILITY REQUIREMENTS

TIME PERIOD: _____
SUPPORTING: _____
PLAYER: _____

CYCLE: _____
DATE: _____

FACILITY OR INSTALLATION	UNIT OF MEASURE	REGION	REQUIREMENT OR INSTALLATION

*See Checklist

Fig. 31—Form 14, Phased Facility Requirements

TABLE 10
Facility Category Assignments

Facility category	Responsible player
Ports	TC
Beaches	↑
Railroads	↑
Roads	↓
Waterways	TC
POL	POL
Hospitals	AMEDS
Signal	SigC
Staging and Training Areas	Tac Ops
Refugee Camps	CA
Rehabilitation Centers	PMG
Stockades	PMG
POW Enclosures	PMG
Storage	Log Ops, all
Shops	All
Post Offices	TAG
Replacement Centers	TAG
Army Airfields	TC
Air Force	Tac Ops CE

TABLE 11
Checklist for Phased Facility Requirements

Facility or installation ^a	Unit of measure	Information required
1. Ports (TC)		
a. Berths, alongside	Each	Ports operated with phased requirement for deep water and coaster berths alongside; linear feet of lighterage required for vessels worked in stream; number of deep water and coaster berths available at each port
b. Lighterage	Linear ft	
c. Anchorage	Each	
2. Beaches (TC)		
a. Ramps, amphibious	Each	Phased landing ramp [landing craft utility (LCU), LCM, DUKW, etc.] requirement; square feet of hardstand at each beach and exit road requirements ^b
b. Ramps, landing craft	Each	
c. Hardstand	Sq ft	
d. Beach stabilization	Sq yd	
e. Exit roads	Mile	
3. Railroads ^c (TC)	na ^d	Phased requirements on map showing the rail net to be operated
4. Roads ^c (TC)	na	Phased requirements on maps showing the COMMZ highway system to be operated; present rated capacity and required capacity
5. Waterways (TC)	na	Phased requirements on map showing canals and rivers to be used and drafts required; linear feet of lighterage space required
6. POL (QMC)		
a. Pipelines ^e	Mile	POL plan showing phased requirements for distribution facilities including rigid and assault pipelines by sizes and capacity, storage, loading facilities, etc.
b. Storage facilities	Thou bbl	
c. Tank car loading stations	Each	

TABLE 11 (continued)

Facility or installation ^a	Unit of measure	Information required
d. Tank truck loading stations	Each	
e. Pump stations	Each	
f. Can washing, testing, and loading facilities	Each	
g. Drum washing, testing, and loading facilities	Each	
h. Tanker mooring facilities	Each	
i. Submarine pipelines	Ft	
j. Booster stations	Each	
k. Miscellaneous	na	
7. General construction		
a. Medical Treatment Facilities (AMEDS)	Each	Phased requirements showing size, number, type of construction, and general location ^f
(1) ADSEC		
(2) Base section (BASEC)		
b. Signal communications facilities (SigC)	Each	Phased requirements showing size, number, type of construction, and location of fixed facilities (see TM 5-301, pp 271-273) ^{f,4}
c. Staging and training areas (DCSOPS)	Each	Phased requirements showing size, number, type of construction, and general location ^f
(1) ADSEC		
(2) BASEC		
d. Refugee camps (CA)	Each	
e. Rehabilitation centers (PMG)	Each	
f. Military stockades (PMG)	Each	
g. PW enclosures (PMG)	Each	Phased requirements showing size, number, type of construction, and general location ^f
(1) Combat zone		
(2) ADSEC		
(3) BASEC		
h. Storage		Phased total storage area required and general location ^g
(1) Classes I, II, III (Pkgd), and IV (ALL)		
(a) Combat zone		
(1) Covered	Thou sq ft	
(2) Open	Thou sq ft	
(b) ADSEC		
(1) Covered	Thou sq ft	
(2) Open	Thou sq ft	
(c) BASEC		
(1) Covered	Thou sq ft	
(2) Open	Thou sq ft	
(2) Class V (OrdCorps, CMLC)		
(a) Combat zone		
(1) Covered	Thou sq ft	
(2) Open	Thou sq ft	
(b) ADSEC		
(1) Covered	Thou sq ft	
(2) Open	Thou sq ft	

TABLE 11 (continued)

Facility or installation ^a	Unit of measure	Information required
(c) BASEC		
(1) Covered	Thou sq ft	
(2) Open	Thou sq ft	
(3) Refrigerated (AMEDS, QMC, SigC)		
(a) ADSEC		
(1) Chilled	Thou cu ft	
(2) Frozen	Thou cu ft	
(b) BASEC		
(1) Chilled	Thou cu ft	
(2) Frozen	Thou cu ft	
i. Shops (All)		Phased requirements for shops by type, size, and general location ^f
(1) ADSEC		
(a) Covered	Sq ft	
(b) Open	Thou sq ft	
(2) BASEC		
(a) Covered	Sq ft	
(b) Open	Thou sq ft	
j. Base post offices (TAG)	Sq ft	Phased requirements by size, type of construction, and general location ^f
k. Replacement centers (TAG)	Each	Phased requirements by size, type of construction, and general location ^f
l. Protective construction	Each	Phased requirements by type, size, and general location for hardened structures
(1) Command posts	Each	
(2) Medical treatment facilities	Each	
(3) Communication centers	Each	
(4) Storage	Thou sq ft	
(5) Personnel	Men	
(6) Miscellaneous	na	
m. Special services	Each	Phased requirements by type (e.g., theaters, chapels, and recreation centers), size, type of construction, and general location ^f
n. Army airfields	Each	Phased requirements showing number, type (fixed wing, heliport, or combination), and size (5, 10, 25 aircraft)
8. Air Force facilities		
a. Airfields (CE)	Each	Phased requirements showing name, location, type (e.g., medium cargo—minimum operational) and size (e.g., squadron)
b. Supporting facilities		
(1) General construction (CE)	na	Same as paragraphs 7a through 7k where applicable
(2) POL (QMC)	na	Same as paragraphs 6a through 6k where applicable
(3) Protective construction (CE)	na	Same as paragraph 7l where applicable

^aNotation in parentheses indicates technical or administrative service responsible for reporting requirements.

^bTabular data to be supplemented with annotated map or overlay.

^cInformation to be provided on map or map overlay.

^dNot applicable.

^eInformation to be supplemented by schematic or map.

^fFor location indicate ADSEC, BASEC, etc.

^gType of construction will be determined by CE player in accordance with administrative-support plan policies.

Workload and Final Troop-List Determination

During the preceding game steps each player responsible for determining support-troop requirements will have accumulated the necessary data. In all cases each player will justify his troop list with clearly defined support statements. Support units are determined on one or more bases of allocation, e.g., command of other support units, proration with tactical units, and workload. Examples of workload categories to be considered are listed in Table 12. Each Player must obtain Controller approval of his workload estimates before final troop-list determination.

TABLE 12
Workload Categories^a

Category	Interested player
Aircraft maintenance	TC
Communications	SigC
Decontamination	CMLC
Equipment overhaul	OrdCorps
Facility construction	CE
Patient load in hospitals	AMEDS
POL system operation	POL
Post office operation	TAG
Railroad net operation	TC
Refugee control	PMG
Supply receipt, storage, and issue	All
Water provision	CE

^aThis tabulation is not exhaustive.

Following the establishment of bases of allocation (including workloads) each player establishes a support troop list for all units for which he is responsible in the game. These lists are compared with the initial troop lists provided on Form 2. Discrepancies are determined and examined; and recommended changes (augmentations or reductions) in the initial troop list are identified on Form 2. The revised troop lists and the justifications for changes are closely reviewed by the Controller. This close review is necessary to produce the minimum final troop list that will adequately accomplish the logistic support of the forces and the campaign presented in the scenario.

Intratheater Review

Following the determination of the various workloads and the final troop list the Controller and Director review not only all the player reports, forms, and recommendations concerning support troops and supply factors but also the adequacy of theater-stock levels and the logistic feasibility evidenced by game results. If final player troop lists and supply-factor recommendations are in close enough agreement with those assumed at the beginning of the cycle and if general feasibility is indicated, game play is terminated and the postgame activity commences. If a mismatch in troop lists or inadequacy in stock levels results, the Controller with appropriate players decides whether or not recycling could resolve the mismatch or inadequacy. If the decision is affirmative, the recycling may include a complete replay of the game or a replay of only those parts of the game that will provide the required data; if the decision is negative, the game play is terminated and the postgame activity commences.

Chapter 5

POSTGAME ACTIVITY

GENERAL

Postgame activity (see Fig. 32) consists not only of reviewing the entire game and preparing, publishing, and distributing the final game report but also of accomplishing several activities of a routine administrative nature. These routine activities include the players' return of classified game papers and reference materials. Classified working papers developed during the exercise must also be destroyed in accordance with current security regulations.

REVIEW AND FINAL GAME REPORT

At the conclusion of game play the Director, Controller, and players review the entire game, and a final game report is prepared for publication and distribution. A specified number of copies of this report are published and submitted to the game sponsor, who then distributes or lends them on request.

The final game report consists of a main report and a number of annexes, all reviewed and edited by the Controller and Director. The main report, which is written by the Controller and the players, usually includes the following:

- (a) Study purpose—problem and background.
- (b) General study considerations—scope of the OPLAN that was gamed, planned concepts of operation, scope of the evaluation, component command and task force plans, summary of the scenario and initial troop list, and summary concept of logistic support.
- (c) Study assumptions—alert actions, mobilization, type of war, interdiction of strategic air- and sealift, and contribution of US, allied, and indigenous forces and resources.
- (d) Discussion of the study analysis—report objectives; environmental effects; major phased support tasks such as combat support (Army aviation, CMLC, CE, and SigC), supply (maintenance and buildup tonnages by class), evacuation and hospitalization, transportation (troop deployment and supply), and services (base development construction, maintenance, personnel, and CA); supporting arm or service shortages (combat support; supply—maintenance and buildup tonnages by class; evacuation and hospitalization; and transportation—troop deployment, supply, and services); effect of earlier mobilization; and transportation.

- (e) Study conclusions—logistic feasibility of the OPLAN, changes in the plan, changes in the Army troop program, and logistic prepositioning.
- (f) Study recommendations—changes in the plan, changes in the Army troop program, and logistic preconditioning.

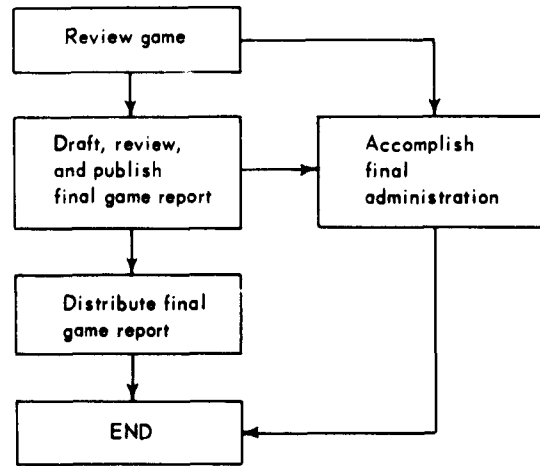

Fig. 32—Postgame Activity Flow Chart

The annexes incorporated in the final game report include the scenario with the initial troop list, the administrative-support plan, and individual-player support-task analyses. In addition to participating in war gaming to produce factors bearing on logistic requirements and the feasibility of the campaign plan, each player is required during game play to develop and evaluate a plan of support for his supporting function, including an analysis of game results, and to complete the write-up of his plan for the final game report. Each annex in the support task analyses must stand on its own, i.e., derive the arm, service, or staff workloads and convert these to phased requirements for pertinent operating units to which normal command, control, and supporting elements can be attached.

Appendix A

TACTICAL SCENARIO

Figures

A1. Form 2, Troop-List Example, Logistic Units	77
A2. Form 2, Troop-List Example, Tactical Units	77
A3. Theater Population by Intensity of Operations	77
A4. Map 1 of 4—Tactical Situation during First Phase of Operation, D - 20 to D+9	78

I. GENERAL

1. Purpose. This paper develops a strategic situation and a scenario of combat operations in (country), an objective area, for use as a vehicle for determining the adequacy of theater reserve supply levels.

2. Basis for the Scenario. The scenario was developed from:

- a. Department of the Army Strategic Logistic Study DA-SL (number).
- b. Theater OPLAN No. _____.
- c. Theater Army OPLAN No. _____.
- d. Base Development Plan No. _____.
- e. National Intelligence Survey Documents _____ (names) _____.
- f. Other Intelligence Documents.

II. SEQUENCE OF EVENTS

Time Period 1 (D-20 to D-11 Days)

Gressorland forces are reported moving into forward positions along the border with Allied Land, the objective area.

There is no indication of imminent major hostilities elsewhere in the world.

Allied Land battle positions are occupied and fortifications are ordered constructed and improved.

Incoming supplies are ordered routed along the LOC intended for war through (ports) and (airfields) to (depots) and (locations).

Drawdown of stocks considered too far forward is ordered, by consumption if possible, otherwise by movement to rear along LOC.

Time Period 2 (D-10 to D-1 Days)

Reconnaissance confirms Gressorland troop movements.

Shipment of supplies is requested expedited to start raising the supply pipeline to wartime size. Supplies in (location) and (location) are ordered shipped to Allied Land. (Special precut) supply requisitions are ordered forward. ETA at D+ _____.

Navy orders (quantity) US-owned and (quantity) chartered shipping to the objective area to provide the commander with some coastwise shipping.

Emergency construction of certain facilities from the Base Development Plan is ordered initiated at once. (A detailed priority list is incorporated in the administrative-support plan.)

A (number) day evacuation policy is ordered for Allied Land. Patients requiring longer treatment are ordered evacuated to (location).

Allied Land reserves are ordered mobilized.

(Quantity) Divisions (Allied Land) are ordered to be mobilized and ready for employment within (number of) days.

(Quantity) Divisions (Allied Land) are ordered mobilized within (number of) days and assigned to (location) for (mission).

All reserve technical service units (Allied Land) are ordered mobilized.

Allied Land Training Command is ordered to continue operations at (location) capacity (strength).

US Army forces available (but not in the objective area) at (location) and (location) are alerted but no movements ordered.

Time Period 3 (D-Day to D + 9 Days)

Gressorland attacks Allied Land with (quantity) Divisions.

Main attack is through (town) toward (city).

Secondary attack is through (town) toward (city).

Holding attacks along rest of front are conducted by Gressorland forces.

Gradual advance is made by Gressorland forces in areas of main and secondary attacks with heavy fighting.

Gressorland has air superiority. Gressorland air attacks are concentrated on US and Allied Land (target types) and at (locations). All stocks at (depot) are destroyed. (Percent) of (class) supplies at (depots) are destroyed.

Shipping into Allied Land ports is interdicted by enemy air and the following losses sustained:

- a. (Number of) ships of (total) tons.
- b. (Number of) tankers of (total) barrels.

Actions taken by various allied and neutral countries are as follows:

USAF attacks Gressorland air bases at (locations) and operates in close support of US and Allied Land troops defending against main and secondary attacks.

US forces are ordered to Allied Land in accordance with OPLAN No. _____ to close as stated in the applicable OPLAN.

The command system and the assignment of units, both US and Allied, is as indicated below:

The (designation) US Log Command commands the COMMZ, including both US and Allied service units. The US does not take over any control of areas or populations in the COMMZ nor does the US take direct control of Allied Land Transportation agencies. Rather, US advisors supervise and influence operations as the Military Assistance Advisory Groups now do.

Time Period 4 (D + 10 to D + 19 Days)

US and Allied Land forces withdraw to positions as follows:

- a. (Designation) (unit) to (defensive position).
- b. (Designation) (unit) to (defensive position).

Other forces hold positions. Similar listing of events for each time period to be played.

III. PHASED TROOP LISTS

Two troops lists are provided for each time period: one for combat units and one for combat and service support units. These lists are prepared on Form 2, "Troop List," and are either included in the tactical scenario or

distributed with it. The data entered are taken from appropriate OPLANs if the game is related to such plans or is derived from existing force planning documents, e.g., an initial troop list, if the game is considering a scenario not directly related to an existing plan. See Figs. A1 and A2.

Logistic Units Page ___ of ___

TOE No.	Designation	Strength	TIME PERIOD					Etc.
			1	2	3	4	5	
5-85D	Const Bn	619	1	1	2	4	4	
5-78D	Supply Co	102	0	0	2	3	3	
Etc.	Etc.	Etc.			Etc.			

NOTE: Units are fictitious

Fig. A1—Form 2, Troop List Example, Logistic Units

Tactical Units

TOE No.	Designation	Strength	TIME PERIOD					Etc.
			1	2	3	4	5	
7-14	Infantry Div	15,000	1	1	2	2	2	
Etc.	Etc.	Etc.			Etc.			

NOTE: Units are fictitious

Fig. A2—Form 2, Troop List Example, Tactical Units

IV. INTENSITY OF OPERATIONS AND DISTRIBUTION OF PERSONNEL BY USER CATEGORY AND REGION FOR EACH TIME PERIOD

Annexes to the scenario are required to show for each time period the intensity of operations and distribution of personnel by user category and region. An operations map accompanies each annex.

Examples of such an annex and its accompanying operations map are provided in Figs. A3 and A4.

		TIME PERIOD					Total by User
USER	REGION	1	2	3	Etc.		
	1	US Corps-Intense		40,000	500		
2	US Corps-Normal	10,000					
3	US Corps-Reduced						
	Etc.						
Total by Location							

Fig. A3 —Theater Population by Intensity of Operations

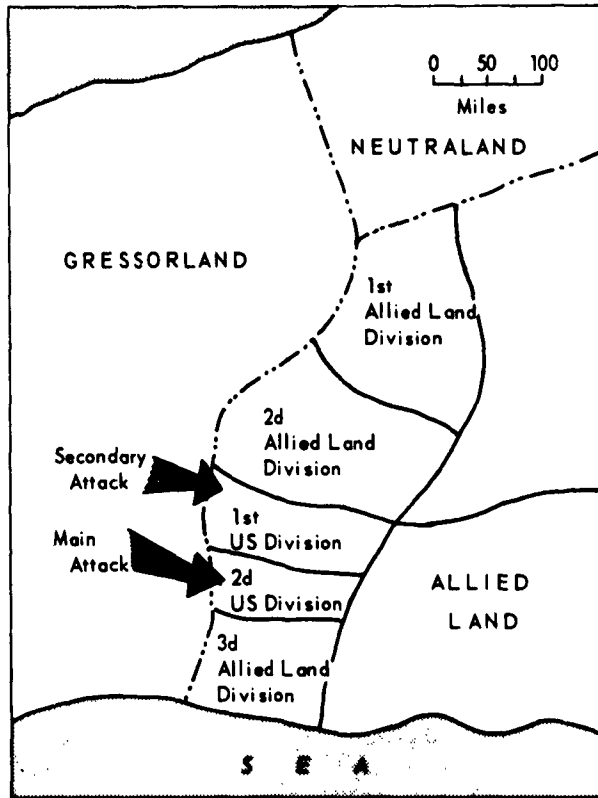

Fig. A4—Map 1 of 4—Tactical Situation during First Phase of Operation, D-20 to D+9
 Maps 2-4 are not provided in this sample scenario

Appendix B

ADMINISTRATIVE-SUPPORT PLAN

Figures

B1. Sample Tabulation of Supply-Consumption Factors, Objective Area	85
B2. Sample Tabulation of Supply-Reserve Buildup Factors, Objective Area	85

1. Purpose. This plan prescribes the concept of logistic support, plans, policies, and factors adopted for war gaming OPLAN (number) (Gressorland vs Allied Land).

2. References.

- a. Annex (number) (Logistics and Personnel), OPLAN (number).
- b. Base Development Plan (number).
- c. National Intelligence Surveys (names).
- d. Intelligence Reports (numbers).
- e. Army Regulations (numbers), which give peacetime supply stockage authorizations.
- f. DA letter, QRST - A40 (date).

3. Assumptions.

- a. Availability of supplies in CONUS is (statement). An average of (number of days) will be required to move supplies from CONUS depots to port terminals.
- b. Authorized reserve levels for US forces in (locations) have been maintained.
- c. Reserve levels for Allied Land forces have not been maintained. Assets to be used are specified in Reference f above.
- d. All units are at full TOE strength in all time periods. The personnel replacement systems of US and Allied Land maintain all units at full TOE strength.

e. All active units have full TE equipment except:

(Designations) and shortages of major importance.

f. Primary consideration is given to movement of military traffic. In addition, minimum essential civilian supplies are transported over the local transportation system although occasionally with some delay. (See Reference c above for civilian requirements.)

g. Areas (locations) are placed on an alert status. (These are areas other than the objective area.)

h. Pre-D-Day disposition of authorized reserve stocks in the objective and nonobjective areas is as stated in paragraph 8c.

i. Movement of supplies to the objective area from nonobjective areas is according to priorities cited in paragraph 8d.

j. No interdiction of strategic sea and airlift is expected to occur.

k. The DA plan for automatic resupply in (location) under wartime conditions is implemented; specifically:

1. Plan No. _____ for US forces.

2. Plan No. _____ for Allied Land forces.

1. All TOE units specified in OPLAN No. _____ are available to support this plan.

4. Mission

a. The logistic mission is to provide or arrange for logistical support to US, Allied Land, and other forces specified in OPLAN No. _____ in accordance with assigned logistical responsibilities. This mission includes:

1. Support of (portion of) US and (portion of) Allied Land and other forces in the area of operations in accordance with provisions of paragraphs 5 and 6.

2. Major forces supported include:

a. US Army.

b. USAF.

c. Allied Land Army.

d. Allied Land Air Force.

e. Etc.

3. Other support missions include:

a. Civilian Labor.

b. Refugees.

c. Prisoners of War.

d. Etc.

b. Detailed descriptions of transportation facilities including ports, beaches, railroads, roads, and airfields can be found in:

1. Base Development Plan.

2. National Intelligence Survey.

3. Etc.

5. Support Concept.

a. The COMMZ will include all of the area of Allied Land up to the rear boundaries of (units).

b. The COMMZ will be designed to support operations along the following LOCs:

(Route designations)

c. Area command with logistic facilities exempted will continue under Allied military territorial agencies.

d. Allied Land government agencies operating in close support of the war effort (such as the railway system) will operate under (command designation).

e. The COMMZ, from depots at (towns) and (locations) will move supplies directly to (tactical units).

f. AF class II and IV supplies will be shipped by air and delivered to air bases in Allied Land.

g. US Navy forces operating in support of the forces in the objective area will be based at (location) and supplied through (location).

h. Local procurement in Allied Land is utilized to the maximum. It is expected that for the first 120 days all food for allied nationals will be obtained locally, etc.

6. Interallied Support.

a. The US supports the Allied Land military forces with all classes of supply except as noted below:

(Supply exceptions)

Allied Land forces requisition supplies from (designation) log command.

b. The US supports other Allied military forces 100 percent except as noted below:

(Support exceptions)

c. Hospitalization.

1. Allied Land forces and other allied forces are hospitalized in facilities staffed by units and personnel of their own nationality.

2. The local government is responsible for hospitalization of civilians not employed by the military.

d. Allied Land forces provide rehabilitation and maintenance of ports, railways, highways, and airfields needed for support of their own forces. Supplies and equipment not locally available will be provided by the US.

e. Maximum use will be made of existing facilities. Local facilities desired by US and allied forces are requisitioned in accordance with agreements stated in reference b.

f. Military telecommunication facilities are installed by (nationality) and operated in accordance with agreement stated in reference a.

g. Support and control of refugees and prisoners of war will be as follows:

(Policies)

7. US Interservice Support.

a. US Army provides logistic support to COMMZ Service troops and Allied army forces other than Allied Land.

b. US Army transports USMC supplies from port of entry to units. USAF provides its own support for classes II, IV less construction, and V(A) and supports Allied Air Force with these classes. US Army provides USAF with classes I, III, III(A), IV construction, and V.

c. US Army establishes procedures for requisitioning common item resupply beginning (time).

d. US Army provides rehabilitation and construction of USAF air bases as required.

e. US Army transportation facilities provide for intratheater movement of USAF class V(A) to USAF bases.

f. Medical service to US forces is provided on the following basis:

(Policies)

g. Aeromedical evacuation will be achieved as stated in reference a.

h. Air transport service between (locations) will be provided by USAF.

i. US Army provides or arranges for rail and highway transportation and, if necessary, installs, maintains, and operates POL pipeline facilities for Army and Air Force.

8. Supply.

a. Supplies accompanying forces arriving in Allied Land are as prescribed in OPLAN No. _____.

b. Supply levels for all active military forces in Allied Land are built up as rapidly as practicable to (number of days) of supply for (classes) except for (class) which is built up to (number) days.

c. Pre-D-Day disposition of authorized theater reserve stocks (expressed in days of supply) is as stated below.

Location	Class				
	I	II	III	IV	V
US Army Forces in Allied Land	30	20	30	10	30
US Army Forces in Second Land	15	20	30	15	45
US Army Forces in Other Land	30	35	15	50	0

d. Supply levels are subdivided within Allied Land as follows:

Forces	Days of supply	Location
US	5	Circleville
	30	Depot, Reartown
	25	Bigtown
Allied Land	5	Combatville
	30	Supplyville
	25	Porticity

e. Theater reserve stocks in the following nonobjective areas are available for movement to the objective area in the following priority:

f. In addition to authorized theater reserves, the authorized peacetime stock safety level and one-half the peacetime operating level are available to meet wartime requirements.

9. Planning Factors (Supply).

a. Initial Equipment.

1. US - (number of) short tons per man multiplied by total increase in strength for period.

2. Allied Land - (number of) short tons per man multiplied by total increase in strength for period.

b. Consumption Factors. See Figs. B1 and B2.

Force and Activity	I	II (less const)	III	IV (const)	V
US Army, intense combat	*	*	*	*	*
US Army, normal					
US Army, reduced					
Etc.					

Fig. B1—Sample Tabulation of Supply Consumption Factors, Objective Area
Pounds per man per day.

*Values not provided. Table for illustrative purposes only.

Force	Class				
	I	II (less const)	III	IV (const)	V
US Army	*	*	*	*	*
USAF					
Allied Land Army					
Allied Land AF					

Fig. B2—Sample Tabulation of Supply-Reserve Buildup Factors, Objective Area
Pounds per man per day.

*Values not provided. Table for illustrative purposes only.

10. Base Development.

a. Maximum use is made of existing facilities, Allied Land labor, and contractual resources.

b. Priority of Engineer tasks (see App ___ of Base Development Plan).

c. Construction Standards. Use Base Development Plan for guidance.

11. Personnel and Administration.

a. Service Troops.

1. US Army reinforcements in service troops arrive on the schedule contained in OPLAN No. _____ .

2. Allied Land reserve service troops are ready for employment in (number of) days after activation is ordered.

b. Military Police.

1. Allied Land controls the civilian population and refugees.

2. US military prisoners are (manner of handling) for (time period).

c. Casualties are estimated in accordance with FM101-10.

d. Evacuation policy is (description). (See scenario.)

REFERENCES

1. Dept of Army, "Army Programs: Priorities for Supply and Oversea Command Levels," AR 11-12, 26 Apr 60.
2. Defense Intelligence Agency, "Airfields and Seaplane Stations of the World," under continued revision. SECRET
3. The George Washington University, Navy Logistics Research Project, "Multi-Mode Transportation Network Analysis," 1 Jul 62. SECRET
4. Dept of Army, "Staff Tables of Engineer Functional Components System," TM 5-301, 15 Nov 57.