

UNCLASSIFIED

AD. 4 5 4 0 1 4

DEFENSE DOCUMENTATION CENTER

FOR

SCIENTIFIC AND TECHNICAL INFORMATION

CAMERON STATION ALEXANDRIA, VIRGINIA



UNCLASSIFIED

NOTICE: When government or other drawings, specifications or other data are used for any purpose other than in connection with a definitely related government procurement operation, the U. S. Government thereby incurs no responsibility, nor any obligation whatsoever; and the fact that the Government may have formulated, furnished, or in any way supplied the said drawings, specifications, or other data is not to be regarded by implication or otherwise as in any manner licensing the holder or any other person or corporation, or conveying any rights or permission to manufacture, use or sell any patented invention that may in any way be related thereto.

5 Armed Forces Inst. of Pathology, Army
Medical Center, Washington, D. C.



SIMPLE AND INEXPENSIVE ANTI-CHOLINESTERASE
DETECTORS FOR FIELD USE

AD No. ~~454014~~

DDC FILE COPY

BY

CAPT. S. I. ZACKS, ~~MC~~ USAR AND BRIG GEN. JOE M. BLUMBERG, ~~MC~~ USA

454014

DDC
RECEIVED
JAN 7 1965
DDC-IRA C

Reprinted from *Military Medicine*, Vol. 120, No. 11, November, 1964

Simple and Inexpensive Anti-Cholinesterase Detectors for Field Use

S. I. Zacks,*

and

Brig. Gen. Joe M. Blumberg, MC, USA†

THE various chemical and histochemical techniques¹⁻⁴ now available for the detection and localization of acetyl cholinesterase activity suggest basic principles from which simple anti-cholinesterase detectors for field use could be developed if the need for such devices exists. These devices should be small, sensitive, inexpensive, and *specifically* detect the presence of anti-cholinesterase agents in air. Quantification is also desirable. The following brief discussion of principles for simple anti-cholinesterase field detectors and presentation of three model devices is intended as a preliminary presentation of what is believed to be a feasible system. It is intended that further development and testing would be carried on by the proper agency.

This discussion will not deal with clinical detection for the following reasons:

Firstly, poisoning of significant degree will be clinically evident to the victim or corpsman so that field testing of blood will be superfluous. Secondly, information derived from devices based on detection of serum cholinesterase inhibition (in blood samples) is not particularly relevant. Since nearly 90% inhibition of serum cholinesterase must occur (in animals) before the acetyl cholinesterase level is seriously affected, measurements of the blood level is only indirectly related to the status of the patient. Furthermore, this method would be cumbersome in the field.

* Presently with The Pennsylvania Hospital, Philadelphia, Pennsylvania.

† The Director, Armed Forces Institute of Pathology, Washington, D.C. 20305.

This investigation was supported in part by a research contract, Project Number 3A01250 1B813, from the Medical Research and Development Command, U. S. Army, Washington, D.C.

Theoretical Considerations

Simply stated, acetyl cholinesterase hydrolyzes acetylcholine yielding acetic acid and choline:

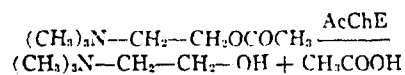

The release of free acid can be utilized to change the color of a pH indicator in a suitable buffered solution. Thus, if inhibited, the enzyme fails to hydrolyze the substrate and no color change occurs. Suitable color controls may be provided for comparison.

Three devices will be described based on these principles.

I. First Device—(Disposable Field Detector)

A polyethylene plastic bag (Fig. 1) approximately $2 \times 1 \times 0.5$ inches, filled with buffer solution containing a pH indicator, is fitted with a cap containing two small bore plastic tubes, one of which extends to the bottom of the plastic bag and is perforated by small holes. Within the plastic bag are two plastic "pods" or bags which contain respectively, acetylcholine solution and dried purified acetylcholinesterase. In use, the air inlet and outlet are opened, pod "A" (dried acetylcholinesterase) is broken by squeezing through the plastic bag. Air to be sampled is pumped through the longer perforated tube and the bag contents. Then the second pod "B" is broken by finger pressure. A change in color of the solution in the bag within seconds indicates hydrolysis of acetylcholine. If the enzyme is inhibited by inhibitors in the sampled air, no color change will be observed. Control color standards may be incorporated in the bag construction for ready comparison. Pilot models using phenol red or bromthymol blue in phosphate buffer ($5 \times 10^{-4}\text{M}$) with acetylcholine (10^{-2}M) as substrate have been made.

Quantification should be possible by varying the number of times the bulb is squeezed (volume of air passed through the solution).

II. Second Device—(Reusable field detector)

A second device, larger and reusable, employs the following reactions:

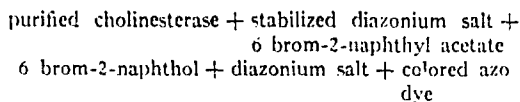

Color formation has been obtained by using diazo blue B, 6 brom-2-naphthyl acetate and purified red cell acetyl cholinesterase. Fig. 2 illustrates this device. It consists of a plastic chamber fitted with a revolving air-tight cap, filter paper containing pods of buffer and substrate solutions. The filter is impregnated with dried acetyl cholinesterase and stabilized diazonium salt. The opposite end of the chamber is fitted with an integral rubber bellows for sampling air. Outflow valves are also provided in the chamber. In use the cap is rotated to the first position where an integral knife edge ruptures the first pod "A" and moistens the filter. Air to be sampled is then pumped through the chamber. The reaction is then completed by rotating the cap to the second position where the second pod "B" is

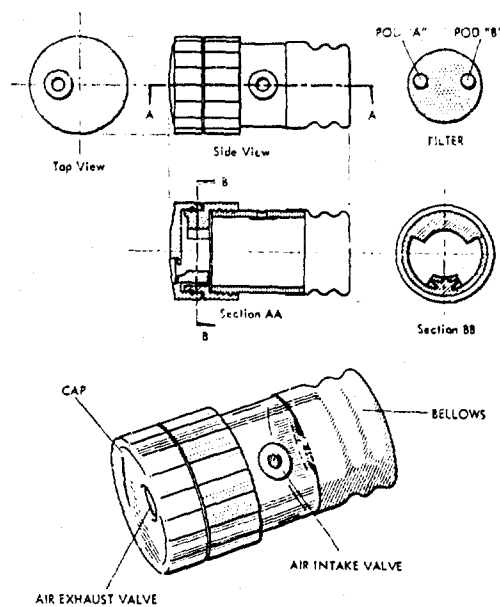

Fig. 2

similarly ruptured. Absence of color production in the filter indicates enzyme inhibition. Quantification based on the amount of air pumped (volume per unit time) should be possible.

This principle might be adapted to the development of patch kits for the exterior of vehicles, soldiers' helmets or gas masks. Such a device is described as III.

III. Third Device—(Disposable) Fig. 3

An airtight foil-covered package containing two pods similar to device II is used. The

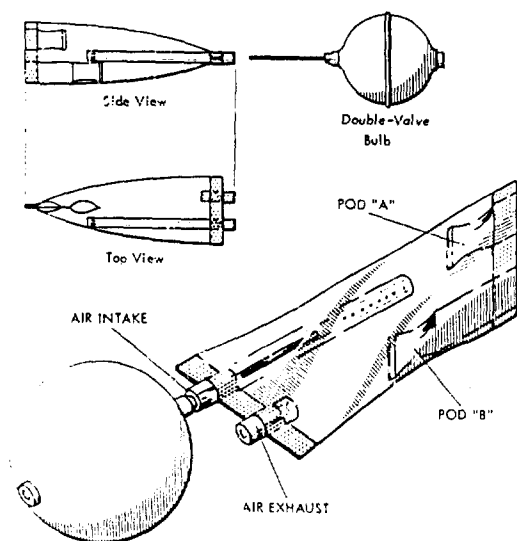

Fig. 1

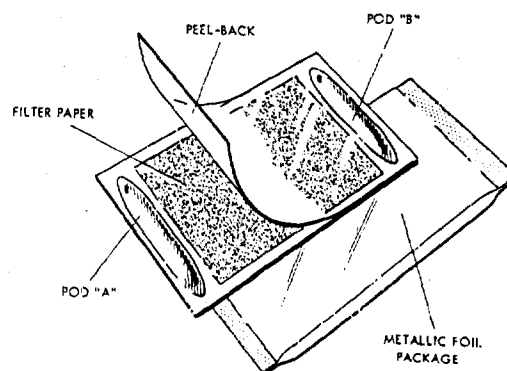

Fig. 3

first pod is broken, the paper is exposed to air following which the second pod is broken to complete the reaction. This device could be produced in any size desired.

Conclusion

Three simple low cost devices are suggested for possible development as anti-cholinesterase detectors for field use. Disposable and reusable devices are described. Successful pre-

liminary tests of the first and second devices have been made with models.

REFERENCES

- ¹Ammon, R. and Jaarma, M.: *The Enzymes I.* Edited by Sumner and Myrback, Academic Press, Inc., New York, N.Y., 1950.
- ²Barnett, R. J. and Seligman, A. M.: *Science*, 114: 570, 1951.
- ³Koelle, G. B. and Friedenwald, J. S.: *Proc. Soc. Exp. Biol. and Med.* 70:617, 1949.
- ⁴Ravin, H. A., Zacks, S. I. and Seligman, A. M.: *J. Pharm. Exp. Therap.* 107:37, 1953.