

UNCLASSIFIED

AD NUMBER
AD462796
NEW LIMITATION CHANGE
TO Approved for public release, distribution unlimited
FROM Distribution: Further dissemination only as directed by HQ Electronic Systems Division, ATTN: ESAT L. G. Hanscom Field, Bedford, Massachusetts, OCT 1963, or higher DoD authority.
AUTHORITY
ESD/USAF ltr dtd 15 May 1968

THIS PAGE IS UNCLASSIFIED

UNCLASSIFIED

AD-462796L

DEFENSE DOCUMENTATION CENTER

FOR

SCIENTIFIC AND TECHNICAL INFORMATION

CAMERON STATION ALEXANDRIA, VIRGINIA



UNCLASSIFIED

NOTICE: When government or other drawings, specifications or other data are used for any purpose other than in connection with a definitely related government procurement operation, the U. S. Government thereby incurs no responsibility, nor any obligation whatsoever; and the fact that the Government may have formulated, furnished, or in any way supplied the said drawings, specifications, or other data is not to be regarded by implication or otherwise as in any manner licensing the holder or any other person or corporation, or conveying any rights or permission to manufacture, use or sell any patented invention that may in any way be related thereto.

L

462796

0

ESD-TDR-63-354, VOL 7

**FINAL REPORT**  
**ON**  
**RANGE INSTRUMENTATION PLANNING STUDY**  
**TECHNICAL DOCUMENTARY REPORT NO. ESD-TDR-63-354**  
**VOLUME 7: DATA PROCESSING AND DISPLAY**

OCTOBER 1963

DDC FILE COPY

DIRECTORATE OF AEROSPACE INSTRUMENTATION  
 DEPUTY FOR ENGINEERING AND TECHNOLOGY  
 ELECTRONIC SYSTEMS DIVISION  
 AIR FORCE SYSTEMS COMMAND  
 UNITED STATES AIR FORCE  
 L. G. Hanscom Field, Bedford, Mass.

**DDC**  
**RECEIVED**  
**MAY 13 1965**  
**DDC-IRA E**

Prepared under Contract No. AF 19(628)-2356

by

TRW Space Technology Laboratories  
 One Space Park  
 Redondo Beach, California

When U. S. Government drawings, specifications, or other data are used for any purpose other than a definitely related Government procurement operation, the Government thereby incurs no responsibility nor any obligation whatsoever; and the fact that the Government may have formulated, furnished, or in any way supplied the said drawings, specifications, or other data is not to be regarded by implication or otherwise in any manner licensing the holder or any other person, or conveying any rights or permission to manufacture, use, or sell any patented invention that may in any way be related thereto.

All distribution of this report is controlled. Qualified Defense Documentation Center (DDC) users should request through HQ Electronic Systems Division, Attn: ESAT L. G. Hanscom Field, Bedford, Massachusetts.

18 19  
ESD/TDR-63-354-VOL. 7

9 FINAL REPORT.

6 RANGE INSTRUMENTATION PLANNING STUDY.

~~TECHNICAL DOCUMENT REPORT NUMBER 63-354~~

VOLUME 7: DATA PROCESSING AND DISPLAY.

11 OCT 1963

12 1 v.

14 Rept no. 8191-6100-RU000-Vol. 1 7

DIRECTORATE OF AEROSPACE INSTRUMENTATION  
DEPUTY FOR ENGINEERING AND TECHNOLOGY  
ELECTRONIC SYSTEMS DIVISION  
AIR FORCE SYSTEMS COMMAND  
UNITED STATES AIR FORCE  
L. G. Hanscom Field, Bedford, Mass.

15

~~Contract~~ AF 19(628)2356

5 TRW Space Technology Laboratories,  
~~Redondo Beach, Calif.~~  
Redondo Beach, Calif.

## FOREWORD

This volume consists of Appendices XXVI through XXXIII, all having the common feature that they are concerned with aspects of data processing and display.

The numbering of the figures, tables, references, and equations is consecutive for the appendices in this volume. For the convenience of the reader, however, the pagination of each appendix reflects the appendix designator; for example, Appendix XXVI has its pages numbered 26-1, 26-2, 26-3, etc.

This volume and the other seven volumes making up this report have a standard table of contents immediately following the abstract page. Additionally a major-heading table of contents for each of the other volumes is shown in reduced size immediately following the standard table of contents. The list of abbreviations and symbols used in the report has been included in each volume.

The STL Document Control Number for Volume 7 is 8691-6100-RU000.

This abstract is UNCLASSIFIED

**RANGE INSTRUMENTATION PLANNING STUDY (U)**

**ABSTRACT**

✓  
The emphasis in space technology over the past several years has shifted to very-long-range missiles, orbiting vehicles, and deep-space probes. Thus support from the test environment is now required on a truly global basis. For this reason, equipment compatibility and a means of integrating the operations of the existing ranges have become necessities.

TRW Space Technology Laboratories (formerly Space Technology Laboratories, Inc.) was awarded a contract by ESD to perform a study of the entire test environment problem for these classes of missions and tests. The primary objective was the definition of what the global test environment should be in the 1965 to 1970 period and the development of an implementation plan permitting the timely and efficient attainment of the recommended configuration.

Emphasis was placed on providing the capability to support the requirements imposed by the many programs involving missiles, large boosters, and spacecraft to be tested in the 1965 to 1970 period. Efficiency was emphasized because it was known that the costs associated with provision of a capability to support such a variety of missions would be very large under the best of circumstances.

STL's conclusion is that an integrated global test environment is not only feasible but highly desirable. The report presents specific recommendations for the choice of prime instrumentation in this integrated global test environment, and develops operational and management concepts appropriate to it. The report includes detailed recommendations, an implementation plan, and applied research and advanced development plans necessary or desirable to assure the timely implementation of the range and to provide a basis for a continuing upgrading of its capabilities.

Volume 1 consists of an overall introduction, a summary of the total report, and a presentation of the basic system concept.

Volume 2 contains a detailed description of the recommended instrumentation network and gives the implementation plan and cost estimates.

Volume 3 summarizes, as functions of time and location, the most stringent requirements imposed on the network; evaluates the network's capability of meeting the test requirements; and presents recommendations for applied research and advanced development programs required to implement the network or to advance the state of the art in pertinent instrumentation technology.

Volumes 4 through 8 contain supporting appendices for the findings, conclusions, and recommendations presented in Volumes 1 through 3.

↑  
Publication of this technical documentary report does not constitute Air Force approval of the report's findings or conclusions. It is published only for the exchange and stimulation of ideas.

C. V. HORRIGAN  
Acting Director  
Aerospace Instrumentation  
Deputy for Engineering and Technology  
Electronic Systems Division

## CONTENTS

## APPENDIX XXVI. DIGITAL DEVICES AND TECHNIQUES

A. Introduction	26-1
B. Logic Elements	26-1
1. Magnetic Logic Elements	26-1
2. Semiconductor Elements	26-3
3. Cryoelectric Elements	26-3
4. Opto-Electronic Elements	26-5
5. Summation	26-5
C. Storage Elements	26-7
1. Magnetic Element	26-7
2. Semiconductor Element	26-9
3. Cryoelectric Elements	26-9
4. Acoustic Devices	26-14
5. Ferroelectric Elements	26-14
6. Contemplated Devices	26-14
7. Summation	26-15
D. Mass Storage	26-19
1. Types of Mass Storage	26-19
2. Mass Memory Applications	26-19
3. Mass Memory Advantages and Disadvantages	26-19
4. Summation	26-19
E. Computer Organizations	26-25
1. "Scratchpad" Techniques	26-27
2. Pattern Recognition Search Techniques	26-28
3. Types of Recognition Memories	26-35
4. The "Virtual Memory" Concept	26-40
5. Homogeneous Storage Cell Structures with Built-in Logic Properties (Logistore Cells)	26-43
6. Optical Computers	26-43
7. Analog-Digital Hybrid Organizations	26-44
8. Block Transfer Techniques	26-45
9. Memory Oriented Computers	26-45
10. Parallel Processors	26-46
11. Summation	26-46

APPENDIX XXVI. DIGITAL DEVICES AND TECHNIQUES (Cont'd)

F. Applications for Recognition Memories	26-50
1. Radar Correlation Techniques	26-50
2. ASW Techniques	26-50
3. Surveillance Techniques for Orbiting Satellites	26-50
4. Secure Communications	26-55
5. Translation	26-55
6. Spaceborne Telemetry (Including Transmission of Biomedical Data)	26-55
7. Remote Data Logging	26-55
8. Communications Buffer	26-55
9. Bubble Chamber Applications	26-56
G. User/Computer Coupling Techniques	26-56
Supplement A	26-57

APPENDIX XXVII. EXECUTIVE CONTROL PROGRAM FOR INSTRUMENTATION STATIONS

A. Introduction	27-1
B. Basic Elements	27-2
1. Traps	27-2
2. Trap Processors	27-2
3. Priority Table	27-4
4. Ordinary Processors	27-4
5. Queue Tables	27-5
6. Mission Subroutines	27-6
C. General Systems Description	27-6
D. Priority Table	27-7
E. Program Details	27-8
1. Trap $T_{1,j}$ (Special Instructions)	27-8
2. Trap $T_{16}$ (Time Trap)	27-11
3. Ordinary Processor $P_2$ (Spacecraft Commands)	27-11
4. Ordinary Processor $P_3$ (Local Data Transfers to Computer)	27-12
5. Ordinary Processor $P_4$ (Data Transfers from Computer)	27-13
6. Ordinary Processor $P_5$ (Acquisition Data)	27-17
7. Ordinary Processors $P_6$ , $P_7$ , and $P_8$ (Telemetry Data)	27-19

APPENDIX XXVII. EXECUTIVE CONTROL PROGRAM FOR  
INSTRUMENTATION STATIONS (Cont'd)

8. Ordinary Processor P <sub>9</sub> (Station Checkout)	27-23
9. Ordinary Processor P <sub>10</sub> (Computer Check)	27-24
10. Ordinary Processors P <sub>11</sub> Through P <sub>14</sub> (Miscellaneous)	27-24
11. Ordinary Processor P <sub>15</sub> (Diagnostic)	27-24
F. Summary	27-25

APPENDIX XXVIII. COMPUTER INTERFACE FOR TELEMETRY DATA

A. General Description	28-1
1. Introduction	28-1
2. System Concept	28-1
B. Input and Output Functional Specifications	28-4
1. Inputs	28-4
2. Outputs	28-5
3. Controls and Indicators	28-5
C. Detailed Descriptions	28-5
1. Terminations and Conversions	28-5
2. Programmer-Format Register	28-6
3. Alternative Programmer	28-15

APPENDIX XXIX. DATA COMPACTION

A. Introduction	29-1
B. Methodology	29-2
1. Editing	29-2
2. Data Reduction	29-3
3. Pattern Recognition	29-3
4. Coding	29-4
C. Design of a Compaction System	29-5
D. Cost Consideration	29-7

APPENDIX XXX. ERROR CONTROL FOR DATA TRANSMISSION

A. Error Control and Range Communications	30-1
B. Some Error-Control Codes and Systems	30-3
1. Error-Detection (ED) and Error-Correction (EC) Codes	30-3
2. Control Systems	30-4
C. Global Range Requirements and Problem Areas	30-5

APPENDIX XXXI. RANGE-ORIENTED PROGRAMMING LANGUAGES	31-1
APPENDIX XXXII. DATA DISPLAY	
A. Introduction	32-1
B. Display/Control Considerations	32-2
1. Display Objectives	32-2
2. Data Presentation	32-4
3. Information Quantities and Rates	32-8
4. Comparative Advantages of Group and Individual Displays	32-13
5. Man-to-Machine Communications	32-14
C. Display Techniques	32-20
1. Group Displays	32-21
2. Individual Display Console	32-55
APPENDIX XXXIII. CONSOLE AND DISPLAY DESIGN FOR THE GLOBAL RANGE	
A. Introduction	33-1
B. Range Control Center Requirements	33-2
1. LRCC Console Functions and Design Objectives	33-2
2. LRCC Large (Group) Display Functions and Design Objectives	33-5
3. GRCC Display and Console Requirements	33-16
C. Mission Monitor and Control Requirements	33-17
1. Information Requirements for Apollo	33-17
2. Information Requirements for X-20	33-19
3. Display Requirements at Remote Sites	33-21
4. Data Analysis and Display for Mission Control	33-25
D. System Implementation	33-29
1. Control Center Requirements	33-29
2. Recommendations for Control Center Display and Console System	33-33
3. Mission Monitor and Control Recommendations	33-49
4. Instrumentation Station Control Recommendations	33-56

ILLUSTRATIONS

APPENDIX XXVI. DIGITAL DEVICES AND TECHNIQUES

1	Thick Film or Woven Wire Screen Memory Array	26-8
2	One-Bit Memory Cell	26-9
3	Memory Cell Packages (3 Components per Bit)	26-10
4	Honeycomb Package	26-12
5	Memory-Oriented Computer – An Illustrative Example	26-47

APPENDIX XXVIII. EXECUTIVE CONTROL PROGRAM FOR INSTRUMENTATION STATIONS

1	Data Process Interface	28-2
2	PCM, FM/FM, PAM-PDM System – Simplified Block Diagram	28-7
3	Programmer and Format Register – Simplified Block Diagram	28-7
4	Syllable Multiplexer	28-9
5	Bit Assembly Shift Register and Controls	28-10
6	Timing Example	28-14

APPENDIX XXIX. DATA COMPACTION

1	Typical Data Compaction System with Retransmission Capability	29-6
2	Typical Storage Requirements	29-8
3	Typical Computation Capacity Required	29-9

APPENDIX XXXI. RANGE-ORIENTED PROGRAMMING LANGUAGES

1	Ideal System for Generation of Computer Programs	31-5
2	Current System for Generating Computer Programs	31-5

APPENDIX XXXII. DISPLAY DATA

1	Flow Diagram of Artoc Display Subsystems	32-24
2	Iconorama	32-27
3	Light Transmission Through Control Layer for Light Valve System of Large Screen Projection	32-31
4	Control-Layer Deformation	32-32
5	Mechanism for Thermoplastic Recording, and Cross-Section of TPR Tape	32-33

APPENDIX XXXII. DISPLAY DATA (Cont'd)

6	Projection System Suitable for TPR	32-34
7	Color Projection Using TPR System	32-36
8	Photochromic Dynamic Display	32-39
9	Large-Scale Full-Color Display System	32-40
10	Display Generator Optics	32-42
11	Full-Color Display Chip Generation	32-43
12	Composite Display Chip	32-44
13	Full-Color Projection System	32-46
14	DODDAC Display Equipment	32-48
15	Electronic Display	32-56
16	Alphanumeric Display	32-58
17	Graphical Display	32-60
18	Individual Display Console Overlay	32-66
19	Message Composing	32-70
20	Display Console	32-73
21	Display Console Block Diagram	32-75

APPENDIX XXXIII. CONSOLE AND DISPLAY DESIGN FOR THE  
GLOBAL RANGE

1	Local Range Control Center Functional Subdivisions and Control Data Flow	33-7
2	Main Operations Area, Local Range Control Center	33-8
3	Perspective Sketch - Main Operations Area, Local Range Control Center	33-8
4	Range Status Progress Display	33-10
5	Mission Status Progress Display	33-11
6	Instrumentation Station Block Diagram	33-23
7	Display Generation and Distribution System	33-35
8	Basic Console	33-47
9	Display Cell	33-51
10	Mission Monitor Console	33-52
11	Mission Monitor Console Display Generation and Distribution	33-53
12	Instrumentation Station Control System	33-57
13	Station Control Console	33-58
14	Data Entry Device	33-58

VOLUME 1 SYSTEM CONCEPT			TRAILAY	VOLUME 8 MISCELLANEOUS CLASSIFIED APPENDICES			
Section	Title	Page	Appendix	Page	Appendix	Title	Page
I	<b>INTRODUCTION</b>	1	VI	26-1	XXXIV	<b>GEODESY</b>	34-1
	A. Background and History	1		26-1		A. Introduction	34-1
	B. Study Objectives and Ground Rules	2		26-1		B. The Geodetic Problem	34-1
	C. Organization of Report	4		26-7		C. Department of Defense World Geodetic System 1960	34-2
II	<b>SUMMARY</b>	5		26-25		D. Electronic Surveying Methods	34-5
	A. Introduction	11		26-50		E. Geodetic Satellites	34-7
	B. Missions and Requirements	12	VII	26-56		F. Project Anna	34-9
	C. Recommended Global Range Complex	16				G. Investigation of Earth Deformation	34-11
	D. Management	22		27-1		H. Present Status of Survey Knowledge at the AMR	34-16
	E. Implementation	26		27-1		I. Summary of Attainable Survey Accuracies	34-17
III	<b>SYSTEM CONCEPT</b>	32		27-2		J. Conclusions	34-21
	A. Introduction	38		27-6	XXXV	<b>STATE-OF-THE-ART SURVEY OF PULSED INSTRUMENTATION RADAR</b>	35-1
	B. Integrated Tracking, Telemetry, and Command Systems	44		27-7		A. Introduction	35-1
	C. Electronic Tracking Systems	47	VIII	27-8		B. Existing Systems	35-1
	D. Calibration of Electronic Tracking Systems	48		27-25		C. New Systems	35-19
	E. Optical Instrumentation	49				D. Other Systems	35-21
	F. Special Metric Instrumentation Problem	54		28-1		E. Subsystems and Components	35-21
	G. Missile Impact Location and Timing	81		28-1		F. Future Systems	35-26
	H. Geodesy and Geophysics	82		28-4	XXXVI	<b>SHIPBORNE METRIC INSTRUMENTATION</b>	36-1
	I. Range Timing	83		28-5		A. Introduction	36-1
	J. Acquisition	84	IX	29-1		B. Summary	36-1
	K. Telemetry	85		29-1		C. Navigation Equipment	36-4
	L. Space Communications	91		29-2		D. Shipboard Tracking Systems	36-13
	M. Space Command	107	X	29-5			
	N. Mobile and Transportable Instrumentation Facilities	111		29-7	XXXVII	<b>METRIC SUPPORT BY MISSION</b>	37-1
	O. Recovery	134	XI	30-1			
	P. Special Siting Considerations	135		30-1	XXXVIIi	<b>INSTRUMENTATION AIRCRAFT</b>	38-1
	Q. Range Safety	141		30-1		A. Introduction	38-1
	R. Frequency Monitoring and Interface Control	147	XII	30-3		B. History	38-5
	S. Secure Data and Command Transmission	148		30-3		C. Philosophy of Aircraft Utilization	38-8
	T. Surface Communications	151		30-5		D. Aircraft Capabilities	38-9
	U. Data Processing	152				E. Mission Requirements	38-63
	V. Operational Control (including Displays and Consoles)	1		31-1		F. Aircraft Requirements	38-76
	W. Management	1		32-1		G. 1965 Capability	38-83
		1	XIII	32-1		H. Aircraft Deficiencies	38-84
		1		32-2		I. Costing	38-85
		1			XXXIX	<b>SEA-SEARCH AND RECOVERY</b>	39-1
		14	XIV	33-1		A. Review of Present Recovery Aids and Supporting Search Vehicles	39-2
		14		33-1		B. Review of Present Procedures and Techniques	39-21
		25		33-2		C. Review of the Test Requirements	39-52
		25		33-17		D. Recommendations	39-72
		26	XV	33-29		E. Equipment and Development	39-83
		26					
		27	XVI				
			XVII				
		1	XVIII				
			XIX				

LIST OF ABBREVIATIONS

ac	alternating current
A/C	aircraft
ACIC	Aeronautical Chart and Information Center
AFC	automatic frequency control
AFCLR	Air Force Cambridge Research Laboratory
AFMTC	Air Force Missile Test Center
AFSC	Air Force Systems Command
AGC	automatic gain control
AICBM	anti-intercontinental ballistic missile
AIL	Airborne Instruments Laboratory
alt	altitude
AM	amplitude modulation
AMR	Atlantic Missile Range
AMS	Army Map Service
approx	approximately
ARDC	Air Research and Development Command
ARPA	Advanced Research Projects Agency
ARS	Air Rescue Service
BECO	booster engine cutoff
BO	burn out
BOA	broad ocean area
bpS	bits per sample
BTL	Bell Telephone Laboratories
BWO	backward wave oscillator
CCMTA	Cape Canaveral Missile Test Annex
cm	centimeter
COM	Chief Operations Manager
CONUS	Continental United States
cps	cycles per second
CRT	cathode-ray tube
CW	continuous wave
CY	calendar year
db	decibel
dbm	decibels referred to one milliwatt
dc	direct current

DCA	Defense Communications Agency
DCS	Defense Communications System
DE	Delco
deg	degree
deg/sec	degrees per second
DOD WGS	Department of Defense World Geodetic System
DSIF	Deep Space Instrumentation Facility
EAFB	Edwards Air Force Base
EBPA	electron beam parametric amplifier
EEG	electroencephalogram
EGO	Eccentric Geophysical Observatory
EKG	electrocardiogram
ESD	Electronic Systems Division
FDM	frequency division multiplex
FM	frequency modulation
FOT	frequency of optimum transmission
fps	feet per second
FSK	frequency-shift keyed
ft	foot
ft/sec	feet per second
g	gravity, acceleration due to
gc	gigacycles per second
GD/A	General Dynamics/Astronautics
GDOP	geometric dilution of precision
GE	General Electric
GERTS	General Electric Range Tracking System
GRCC	Global Range Control Center
HF	high frequency
hr	hour
HU	Hughes Products
ICGM	Intercontinental Global Missile
IF	intermediate frequency
IFCS	information flow control station
IGC	inertial guidance and control
IMCC	Integrated Mission Control Center
in.	inch

IR	infrared
IRBM	intermediate range ballistic missile
IRIG	inter-range instrumentation group
ISB HF	independent sideband high frequency
JPL	Jet Propulsion Laboratory
<sup>o</sup> K	degrees Kelvin
kbits/sec	kilobits per second
kc	kilocycles per second
Kev	thousands of electron volts
km	kilometer
kw	kilowatt
LASV	Low-Altitude Supersonic Vehicle
LF	low frequency
LOS	line of sight
LRCC	local range control center
LUF	lowest usable frequency
m	meter
MATS	Military Air Transport Service
max.	maximum
mc	megacycles per second
MCC	mission control center
MEC	Microwave Electronics Corporation
MECO	main engine cutoff
megw	megawatt
Mev	millions of electron volts
MH	Minneapolis Honeywell
mi	miles
MILS	missile impact location system
Mil Spec	military specification
MIT	Massachusetts Institute of Technology
mm Hg	millimeters of mercury
MMRBM	mobile, medium-range, ballistic missile
mr	milliradian
msec	millisecond
MO	Motorola
MTBF	mean time between failures

MTS	members of the technical staff
MUF	maximum usable frequency
mw	milliwatt
NA <sup>SA</sup>	National Aeronautics and Space Administration
nmi	nautical mile
NAFPA	U. S. Naval Missile Facility, Point Arguello
OAO	Orbiting Astronomical Observatory
OD	Operations Directive
OGO	Orbiting Geophysical Observatory
ORV	ocean range vessel
OSO	Orbiting Solar Observatory
PACM	pulse-amplitude code modulation
PAFB	Patrick Air Force Base
PAM	pulse-amplitude modulation
PCA	polar cap absorption
PCM	pulse-code modulation
PD	pulsed doppler
PDM	pulse duration modulation
PELT	precision early launch tracker
PH	Philco
PIRD	Program Instrumentation Requirements Document
PM	phase modulation
PMR	Pacific Missile Range
PN	pseudonoise
POGO	Polar Orbiting Geophysical Observatory
PPE	preliminary planning estimate
ppi	plan position indicator
ppm	parts per million
pps	pulses per second
PRF	pulse repetition frequency
PSK	pulse-shift keyed
R and D	Research and Development
RARR	range and range rate
RAY	Raytheon
RCA	Radio Corporation of America
ref	reference

RF	radio frequency
RIPS	Range Instrumentation Planning Study
RISE	Research in Supersonic Environment
rms	root mean square
rss	root sum square
RTG	radio-isotope thermoelectric generators
SCF	Satellite Control Facility
sec	second
SGLS	Space-Ground Link Subsystem
SLAM	Supersonic Low-Altitude Missile
smi	statute mile
S/N	signal-to-noise
SOFAR	Sound Firing and Ranging
SPO	Systems Project Office
Sps	samples per second
SRM	Systems Requirements Model
SSB	single sideband
SSD	Space Systems Division
SSN	sunspot number
STL	TRW Space Technology Laboratories
STV	special test vehicle
SWF	short-wave fadeout
SY	Sylvania
TASI	time assignment speech interpolation
TDM	time division multiplex
TI	Texas Instruments
TLM	telemetry
TR	Transitron
TTC	tracking, telemetry, and command
TTY	teletype
TV	television
TWT	traveling-wave tube
UFS	Unified Frequency System
UHF	ultra-high frequency
$\mu$ rad/sec	microradians per second
USA WGS	United States Army World Geodetic Systems

USAF WGS	United States Air Force World Geodetic System
$\mu$ sec	microsecond
VAFB	Vandenberg Air Force Base
VECO	vernier engine cutoff
VHF	very-high frequency
VLF	very-low frequency
w	watt
WE	Western Electric
wpm	words per minute
ws	watt-second
WSMR	White Sands Missile Range
Xpdr	transponder

## Appendix XXVI. DIGITAL DEVICES AND TECHNIQUES

### A. INTRODUCTION

The 17 years that have elapsed since ENIAC was dedicated at the Moore School of Engineering in the University of Pennsylvania have witnessed the growth of an impressive and promising technology. This appendix does not aim at reporting the status of such growth; rather it will discuss the new insights that have been brought to bear on the computer technology and the extent to which the influx of new devices, techniques, and organizations is going to shift the potential design and application patterns in digital computers. A summary of such devices, techniques, and organizations is shown in Table I.

The wide gamut of devices and organizations shown in Table I is related to off-the-shelf items, as well as contemplated approaches. A brief evaluation and critique of the more prominent devices and approaches follow.

### B. LOGIC ELEMENTS

With the advent of the solid-state computer a decade ago, device research has been practically synonymous with solid-state science. The trends in component research today are aimed towards increased switching speed, higher package density, improved reliability, and lower cost.

#### 1. MAGNETIC LOGIC ELEMENTS

Significant advances have been made in magnetic thin film and multiaperture core logic circuits (involving orthogonal fields such as the biax). Available magnetic circuits are slow. Conventional ferrite devices need hundreds of nanoseconds for switching. Since multiphase operation is necessary to obtain directivity and decoupling, the bit-transfer time is usually 5 to 10  $\mu$ sec or more. The use of magnetic thin films gives promise of logic circuitry operating at least two orders of magnitude faster than conventional ferrite core circuitry. The high anisotropy of films provides gain and nonlinearity while the topology of the circuit together with multiphase operation gives directivity and logical inversion. Circuits are still in an early experimental state.

Table I. Digital Computer Devices and Organizations

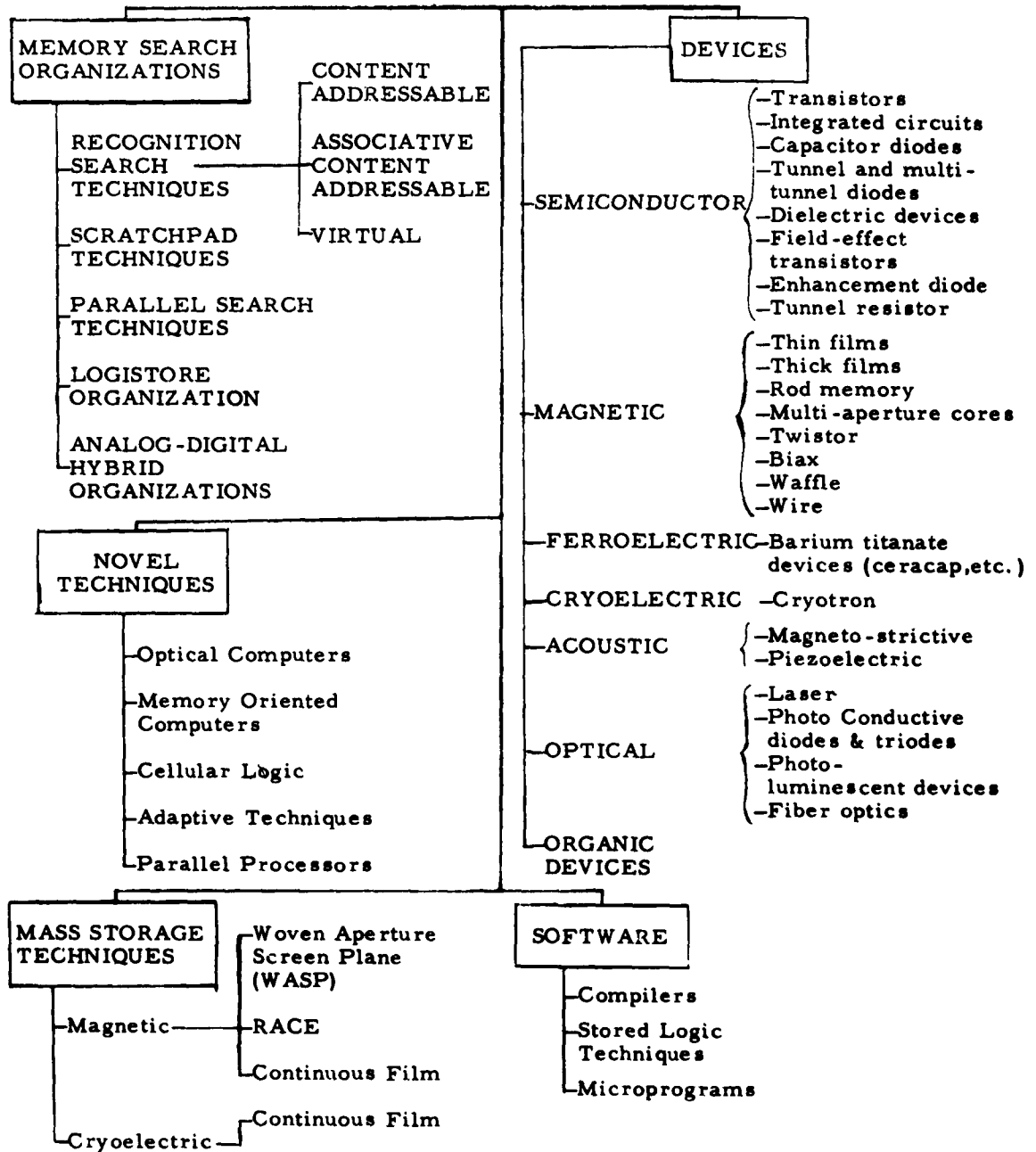

## 2. SEMICONDUCTOR ELEMENTS

Semiconductor devices are continuing to be thoroughly investigated to improve their application in logic functions. It appears that the switching-speed barrier is in the region of 1 nsec for transistors, but much lower (around 1 picosecond) for tunnel diodes with gain-bandwidth products of  $10^{12}$  cps and higher and thin film triodes such as the space-charge-limited, hot electron, and field effect types. Of the effort being directed towards devising new methods of fabricating semiconductor devices, the more promising and prominent are related to integrated circuits.

Integrated-circuit technology appears to promise low production costs with high mean-time-between-failure (MTBF) figures (in excess of 10,000 hours per 2,000 components), and improved logistics, as early as the last quarter of 1964. The rather low module yield presently encountered by the various integrated-circuit manufacturers, and the relatively high price of modules, may be overcome through technological advances as well as acceptance of the "minimum integrated-circuit" (MIC) concept whereby the number of elements diffused onto the semiconductor wafer are kept to a minimum. By adopting such a concept, capacitors and resistors exceeding 5000 ohms are employed as discrete components external to the circuit module. Although the tolerance for diffused resistors is high (20 percent or so), lower tolerance values (5 percent or so) can be attained through a separate film-deposition process at added cost.

Table II summarizes the more significant aspects related to the current approaches of integrated-circuit manufacturers.

## 3. CRYOELECTRIC ELEMENTS

The switching speed of the cryotron is fast only under certain artificial circumstances. The basic cryotron cell offers both logic and storage capabilities, making possible computer subunits with a minimum of transfers because the two device functions can be interlaced in the physical structure. Thin-film fabrication techniques appear to promise an extremely inexpensive device. Because of the relatively high refrigeration costs, the element appears to be more applicable to the

Table II. Integrated Circuits – State-of-the-Art  
Figures of Merit (As of March 1963)

**A. Tape Memory**

Family	Device	Maximum bpi and Recording Mode (bits/inch)	Tape Length (ft)	Storage Density (bits/ft <sup>2</sup> ) (b)	Weight (lbs/bit)	Approximate cost/bit (\$/bit) (b)
IRON OXIDE	MAGNETIC TAPE (a)	0.43 mil coating	800 NRZI	3600	4.5 x 10 <sup>9</sup>	0.93 x 10 <sup>-4</sup>
			556 NRZI	3600	3.1 x 10 <sup>9</sup>	1.34 x 10 <sup>-4</sup>
			1100 PHASE	3600	6.2 x 10 <sup>9</sup>	0.68 x 10 <sup>-4</sup>
	0.18 mil coating	*1200 NRZI	4600	8.7 x 10 <sup>9</sup>	0.49 x 10 <sup>-4</sup>	*0.14 x 10 <sup>-4</sup>
		*2500 PHASE	4600	18 x 10 <sup>9</sup>	0.23 x 10 <sup>-4</sup>	*0.07 x 10 <sup>-4</sup>

**B. Tape Transport System (c)**

Tape Speed (inches/sec)	Start Time (ms)	Stop Time (ms)	Maximum Bit Density (bpi)	Recording Mode	Maximum Tape Width (inches)	Operating Temperature (°F)
30	10	10	200	NRZI	1/2	50-90
75	3.3	2.5	556	NRZI	1/2	50-90
120	2.0	1.5	556	NRZI	1"	60-80
133	2.0	1.5	900	NRZI (g)	1"	60-80
*150	* 2.0	* 2.0	*1200	NRZI	1"	*60-80
*150	* 2.0	* 2.0	*2500	PHASE	1"	*60-80

Tape Speed (inches/sec)	Maximum Data Rate (characters/sec) (d)	Maximum Capacity (characters) (d, e, f)	Power Consumption (watts/bit) (f, h)	Approximate Cost Of Memory System/Bit		
				1960-62	1963	1966
30	6.0 x 10 <sup>9</sup>	0.86 x 10 <sup>7</sup>	13.6 x 10 <sup>-4</sup>		\$12.5 x 10 <sup>-4</sup>	
75	41.7 x 10 <sup>9</sup>	2.4 x 10 <sup>7</sup>	7.7 x 10 <sup>-4</sup>	\$8.3 x 10 <sup>-4</sup>		
120	131.4 x 10 <sup>9</sup>	4.8 x 10 <sup>7</sup>	8.0 x 10 <sup>-4</sup>	\$14.5 x 10 <sup>-4</sup>		
133	240 x 10 <sup>9</sup>	7.8 x 10 <sup>7</sup>	3.2 x 10 <sup>-4</sup>		\$11.0 x 10 <sup>-4</sup>	
*150	*360 x 10 <sup>9</sup>	*13 x 10 <sup>7</sup>	*1.9 x 10 <sup>-4</sup>			Unknown
*150	*750 x 10 <sup>9</sup>	*27 x 10 <sup>7</sup>	*1.0 x 10 <sup>-4</sup>			Unknown

(a) Figures given are for 1/2" tape width, 1.0 mil mylar base, and 10 1/2" reel. 1 1/2 mil mylar base is also used, but has 2400 ft. instead of 3600 ft. on a 10 1/2 inch reel. One inch tape widths are also used, with two (instead of one) 7 bit characters generally recorded on parallel tracks.

(b) Includes 10 1/2" precision aluminum reel, and based on maximum bpi with no allowance for interrecord gaps, and considering 7 bit character recorded on parallel tracks. Costs are for reel and tape only.

(c) Typical systems are given for various performance categories. There are very many systems within this range and special systems beyond the maximum range have been made.

(d) Multiply by 7 to get bits—data rates and capacity usually specified in characters/sec since inputs and outputs to digital transports are bit parallel character serial.

(e) For one 10 1/2" reel of 1 mil mylar base tape of width specified at maximum bpi with no interrecord gaps.

(f) Overall memory, based on 1 x 1 system with tape as specified in (b) and excluding control electronics. Quantity discounts not considered here. Typically computer tape memories are arranged in multiples of four or more with a corresponding increase in maximum capacity and power consumption and a decrease in cost/bit by approximately 25%.

(g) There are phase mode recording systems in this same performance and cost range.

(h) Maximum operating power. Standby power is approximately 40% less.

for 0.18 mil coating

design of very large scale organizations, such as gigabit memories or memory organized computers. These will be capable of operating at clock rates of the order of 1 mc.

#### 4. OPTO-ELECTRONIC ELEMENTS

It is possible that many operations presently performed in computers by electronic and magnetic components can be taken over by optical or opto-electronic techniques. From the standpoint of large-scale operational systems to be used within the next 5 years or so, opto-electronic logic will have little impact on the design of computer systems.

#### 5. SUMMATION

##### a. Logic Elements

Logic elements will be available for operational use that will switch in 0.1 nsec or less. These will yield logic circuits having stage delays of one or more orders of magnitude larger than this. However, these circuits, when integrated within a system, will be capable of operating reliably at repetition rates of only a few hundred megacycles. It will be the circuit and its method of use in a system, rather than the device, that will restrict the speed that can be attained in a computer. For operation in the UHF band, three types of circuits appear promising, all employing tunnel diodes:

The General Electric Approach: Hybrid circuits employing tunnel diodes and transistors permit processing of data in the 200 mc to 500 mc bit range. The standard logical building block is a NOR gate with a fan-in of 3 and fan-out of 3. Fan-in and fan-out of 6 are also possible.

The RCA Approach: Tunnel-diode logic circuits employing a tunnel resistor are capable of shifting and counting at 300 mc.

The Univac Approach: Tunnel-diode logic circuits employing a charge-storage diode ("enhancement diode") provide fan-out current units as high as 10. The charge-storage diode is used in a gate and as a diode amplifier while the tunnel diode provides high gain without loss of bandwidth.

b. Integrated Circuits

Integrated circuits will provide extremely high package density at reduced cost and permit field maintenance by unskilled personnel. Techniques will also permit microwatt and nanowatt logic circuits capable of operating at clock rates in the mc domain. The rather high MTBF figures may yield improved logistics.

c. Superconductive Thin Films

Because of the relatively high refrigeration costs, it is believed that superconductive thin-film technology is more applicable to the design of very large capacity memories, say, 1 megabit and larger, with access times of  $1/2$   $\mu$ sec and slower, and memory-oriented computer type organizations operating at say, 1-mc clock rates, rather than the application to the performance of simple logic functions. Because cryoelectric devices can be fabricated inexpensively, it is possible to construct highly parallel, homogeneous machine structures that promise ultrafast system speeds equivalent to conventional systems operating at gc clock rates.

## C. STORAGE ELEMENTS

### 1. MAGNETIC ELEMENT

The well-proved magnetic core still remains the basic element of most computer memories. Refinements are related to configuration, e. g., smaller dimensions and change of shape, such as multiaperture plates, and to the ferrite materials involved, such as change of shape of the hysteresis loop. The possibility of evaporating arrays of magnetic thin films aims at obtaining very large memories (megabits) at reasonable cost (25¢ to 50¢ per bit for 0.5- to 1- $\mu$ sec cycle times), and very fast (0.01 to 0.1  $\mu$ sec) small memories for scratchpad applications. Present investigations on the switching behavior of magnetic films show that 5- to 10-nsec cycle times will probably be attainable and that this technology is amenable to nondestructive readout. The primary obstacles are:

Attainment of uniformity of magnetic characteristics  
in thin films

Relatively high drive powers

Extremely low signal-to-noise ratios impeding successful  
signal detection on the sense wires.

The magnetic thick-film memory (or the "woven wire screen memory") represents an outgrowth of thin magnetic film research. In essence, the device shown in Figure 1 consists of a mesh or screen of rectangular magnetic storage cells formed by weaving bare wire and then plating with magnetic material. Each cell thus formed is interlaced with insulated unplated conductors woven as an integral part of the screen to provide electrical control and sense. Being entirely woven, the device lends itself to efficient machine-fabrication techniques. Cell densities of the order of 100/in<sup>2</sup>; selection ratio of 3:1; 0.4- $\mu$ sec switching time; 1:10 discrimination ratio; and 30-mv peak readback signal have been obtained with experimental prototypes. The result provides an extremely inexpensive memory array (0.1 to 0.5¢ per cell) which has properties competitive with, and in many respects surpassing, ferrite core storage: notably, in greater tolerance of temperature, shock, and vibration, and versatility in physical shape.



Figure 1. Thick Film or Woven Wire Screen Memory Array

For READ MOSTLY applications, the BIAX appears to be the most economical off-the-shelf storage element. It can offer WRITE cycle times of 3  $\mu$ sec with a total READ access time of 80 nsec and higher, depending on the size of the memory.

## 2. SEMICONDUCTOR ELEMENT

For the present, tunnel diodes appear to offer the best practical approach to random-access scratchpad memories with cycle times in the 10- to 100-nsec range. With integrated circuits and epitaxial techniques, it is possible to deposit a memory array of about 256 bits (16 x 16) on a single silicon wafer. The governing factor is the eventual cost per bit. The same factor governs the fabrication of scratchedpad memories employing integrated transistor flip-flops, the "transbit" memory. Semiconductor memories employing transistors and tunnel diodes require dc holding power, which is not necessary with hysteretic devices.

Figure 2 shows a typical one-bit memory cell. Different cell packages are shown in Figure 3. A honeycomb type housing for the cells is shown in Figure 4. In (b) and (c) the cell bit is housed in single TO-14 and TO-46 transistor packages, respectively. The honeycomb package consists of RF shielding, heat sink, and octagon cells 1/8" across flats (64 to the square inch), approximately 1/4" thick and provides means to hold components at the body rather than at the leads. All connections shown are spot-welded. Predicted characteristics for an experimental tunnel-diode memory are given in Table III.

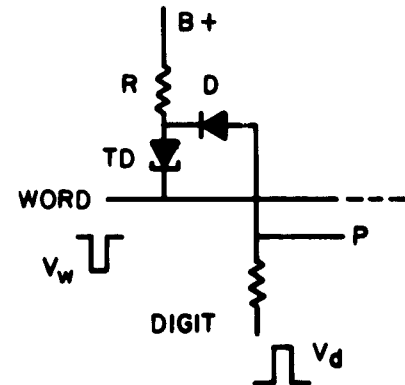

Figure 2. One-Bit Memory Cell

## 3. CRYOELECTRIC ELEMENTS

Superconductive thin-film technology is more applicable to the design of very large capacity memories, perhaps of 1 megabit and larger with access times of 1/2  $\mu$ sec and slower, rather than very fast scratchpads. For example, the cost per bit to maintain superconducting temperatures would be rather high for a 5000-bit cryoelectric memory.



Figure 3. Memory Cell Packages (3 components per bit)



Figure 3. Memory Cell Packages (3 components per bit) (d)

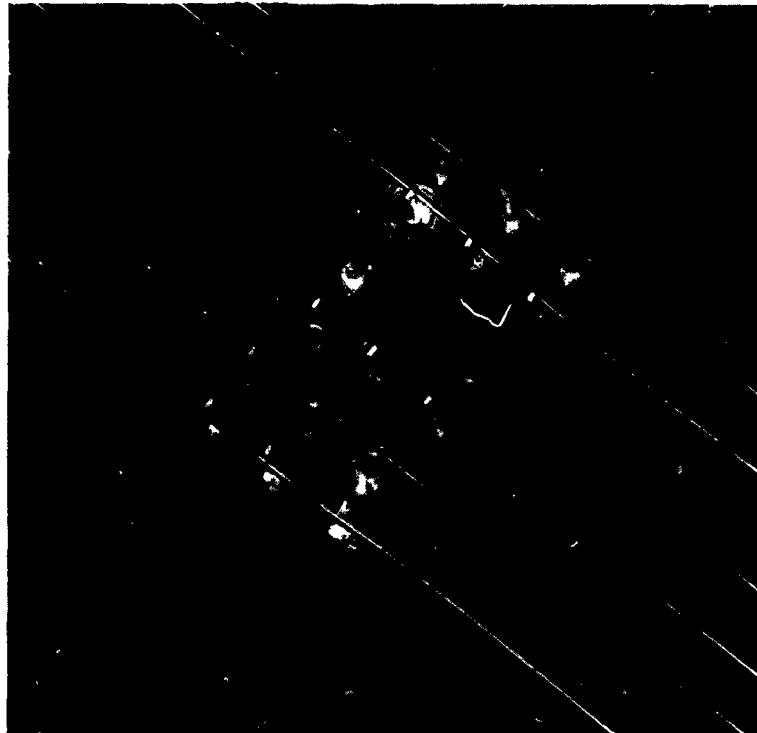
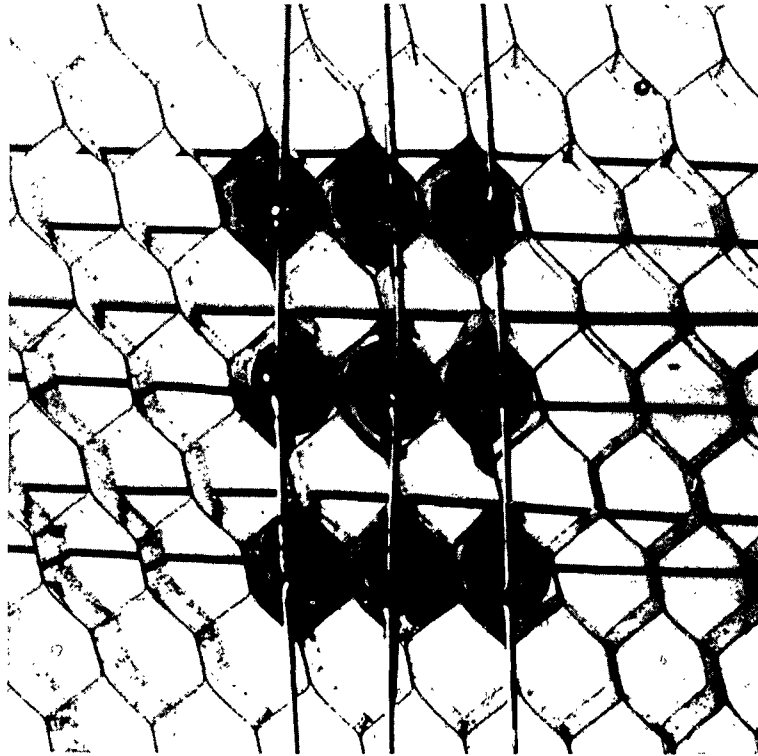

Figure 4. Honeycomb Package

Table III. Predicted Characteristics for Experimental Tunnel-Diode Digital Storage

<u>Capacity</u>	5120 bits
<u>Access</u>	
Type	Random
Time	25 nsec
<u>Clock rate</u>	Variable to 40 mc
<u>Storage density bits/cu ft</u>	$2 \times 10^5$
<u>Power consumption watts/bit</u>	2 mw
<u>Driving power watts/bit</u>	1 mw
<u>Weight (including power supply) lb/bit</u>	$5 \times 10^{-4}$
<u>Resistance to radiation</u>	
Shock	Excellent
Nuclear	$10^{17}$ nvt
Temperature changes	-85°C to 200°C with Si diodes
<u>Cost/bit</u>	
1961	\$6.00
1964	\$0.80

#### 4. ACOUSTIC DEVICES

Acoustic delay lines are available for megabit storage at rates up to 20 mc. However, fast scratchpad use cannot be readily implemented because only microsecond access time is possible, the type of storage is sequential (or serial), and the clock rates cannot be varied.

#### 5. FERROELECTRIC ELEMENTS

Barium titanate elements (the ceracap for example) are available that exhibit the electrostatic, or capacitive, analogy of the familiar electromagnetic or inductive saturable reactor. These elements are capable of operating at higher frequencies than cores, require lower power drives, yield comparatively high signal outputs, and lend themselves to low-cost mass production. Their use as storage and logic devices has been limited by temperature dependence and lack of complete understanding of the materials used.

#### 6. CONTEMPLATED DEVICES

Numerous basic avenues are being pursued to obtain a new generation of digital memories. Such concepts include parametric devices, quantum mechanical secondary tunnelling of electrons, tunnelling of dielectrics (related to the electron transport mechanism observed in 10 to 100 Å dielectric thin films and utilized in devices such as the metal interface triodes), and quantum level devices. The latter includes gaseous, solid-state, F center trapping, laser, and maser devices where quantum mechanical energy levels, representing quiescent states of equilibrium, are stimulated externally to induce electronic transitions between such levels. With the advent of the laser, beams can be provided that can be focused to a spot of the order of a wavelength in diameter with the highest possible intensity. Thus, it is conceivable to employ quantum energy levels in atomic structures to store information. It has been roughly estimated that one bit could be stored in  $10^{-10}$  cm<sup>3</sup>. These techniques are in the experimental stages and will have little or no impact on operational equipments to be designed within the next 5 years or so.

Tables IV, V, and VI compare performance characteristics for the various storage elements from the standpoint of technology, speed, size, and organization.

## 7. SUMMARY

### a. Coincident-Current Ferrite Memories

One  $\mu$ sec cycle time is possible with coincident-current type ferrite memories. With linear select techniques, access times of the order of hundreds of nanoseconds are possible.

### b. Superconducting Thin Films and Woven Screens

Superconducting thin-film and woven-screen (thick-film) techniques have the potential of offering economical, nonrotating type, gigabit memories. The woven-screen memory appears to offer overall significant advantages for operational use within about 5 years. For example, the maximum capacity per plane is 64,000 bits with a maximum capacity per module of  $2.5 \times 10^6$  bits for  $10^6$  cycle times at 1¢ per bit maximum. Memory planes have been successfully tested at  $104^\circ\text{C}$ .

### c. Magnetic Thin Films

Magnetic thin-film techniques will offer economical structures of approximately  $10^6$  bits at read-write cycles of the order of about 100 nsec. Certain thin-film techniques will permit faster nondestructive readout rates of 20 to 40 nsec with write rates of the order of 200 nsec for memory capacities of the order of  $1/4 \times 10^6$  bits.

### d. BIAX

For READ MOSTLY applications, the BIAX appears to be the most economical off-the-shelf storage element. It can offer WRITE cycle times of 2- to 3- $\mu$ sec with a total READ access time of 80 nsec or higher, depending on size of memory.

### e. Tunnel Diodes

For the present, tunnel diodes appear to offer the best practical approach to random-access scratchpad memories with cycle times in the 10-nsec range.

FAMILY	DEVICE	DEVICE SWITCHING TIME ( $\mu$ SEC)	TYPE OF ACCESS	READ ONLY ( $\mu$ SEC)	WRITE ONLY ( $\mu$ SEC)	READ WRITE CYCLE ( $\mu$ SEC)	STORAGE DENSITY (g) (BITS/CU. FT.)	POWER CONSUMPTION (h) (WATTS/BIT)	WEIGHT (LBS/BI)
Ferri-magnetic	Coincident Current Core 50/30 mil 30/20 mil *22/14 mil	0.7	Random	2.0(a)	2.5(b)	6	$1.4 \times 10^4$	$2.8 \times 10^{-3}$	1.7 x 10
		0.4	Random	.75(a)	1.2(b)	2	$2.4 \times 10^4$	$1.6 \times 10^{-3}$	*2.0 x 10
		*0.25	Random	*0.4(a)	*0.8(b)	*1.3	* $3.5 \times 10^4$	* $1.2 \times 10^{-3}$	*1.5 x 10
	Linear Select Core 30/20 mil 30/20 mil *22/14 mil 50/10 mil "milli-ferrite"	0.2 (d)	Random	1.0(a)	Not applicable	1.5	$0.37 \times 10^4$	$5.4 \times 10^{-3}$	9.6 x 10
		0.15(d)	Random	0.4(a)		1.0	$0.75 \times 10^4$	$2.7 \times 10^{-3}$	7.2 x 10
		*0.10(d)	Random	*0.20(a)		*0.5	* $1.5 \times 10^4$	* $2.0 \times 10^{-3}$	*5 x 10
		*0.07(d)	Random	*0.15(a)		0.375	* $0.30 \times 10^4$	* $2.0 \times 10^{-3}$	
		**0.03(d)	Random	**0.07(a)		**0.15	** $0.50 \times 10^4$	** $3.0 \times 10^{-3}$	
	MAD Ferrite trans-fluxor Fluxor permalloy sheet 1/8 to 1.0 mil thick	*0.6-2	Random	*1.0	*2.5	Not applicable	* $0.2 \times 10^4$	* $6.9 \times 10^{-3}$	
		*0.02-2	Random	**0.05-4	**0.15-3.5		* $0.25 \times 10^4$	** $6 \times 10^{-3}$	
Ferri-magnetic									
Ferri-magnetic	READ ONLY wired core intersection E-core Slug memory		Random	0.3-1.0(a)		0.5-2.0(j)	$1.4-2.4 \times 10^4$	$1.6-2.8 \times 10^4$	2.0 x 10
			Random	*0.3(a)		*0.75(j)	* $0.2 \times 10^4$	* $1.3 \times 10^4$	
			Random	*0.3(a)		*0.75(j)	* $0.2 \times 10^4$	* $1.3 \times 10^4$	
	Random	0.2(a)		0.3(j)					
	BIAx	Read less than .01 $\mu$ S Write-.25 to 1.0 $\mu$ s than .01 $\mu$ S	Random	0.5	3	5		Read 2 MCS 3-6 mw/bit Write 33KC 3 mw/bit	$5 \times 10^{-1}$

\* READ, WRITE AND CYCLE times, as well as Maximum Capacity are indicative of the state-of-the-art and are NOT interrelated

(a) Data availability—complete cycle for read (i.e. before next read operation allowed) is the same as read/write cycle.

(b) Buffer operation only.

(c) Special memories -65 to 85°C.

(d) Partially switched mode.

(e) No special requirement for commercial memories. Special memories have been mil spec qualified as high as 200 g shock, 25 g vibration, 15 g acceleration.

\*Projected characteristic.

\*\*Estimate based on supplier announcements, but not known to

\*\*\*Resistance to nuclear radiation is limited only by associated



Table IV. Magnetic Memory Systems\*

STORAGE DENSITY (g) (BITS/CU. FT.)	POWER CONSUMPTION (h) (WATTS/BIT)	WEIGHT (LBS/BIT)	SHOCK AND VIBRATION	RESISTANCE TO NUCLEAR RADIATION	OPERATING RANGE	RATE (BITS/SEC)	MAXIMUM CAPACITY	APPROXIMATE COST MEMORY SYSTEM/BIT(f)			REMARKS
								'60-'62	'63	'66	
1.4 x 10 <sup>4</sup> 2.4 x 10 <sup>4</sup> *3.5 x 10 <sup>4</sup>	2.8 x 10 <sup>-3</sup> 1.6 x 10 <sup>-3</sup> *1.2 x 10 <sup>-3</sup>	1.7 x 10 <sup>-5</sup> *2.0 x 10 <sup>-5</sup> *1.5 x 10 <sup>-5</sup>	(e) (e) (e)	*** *** ***	0-50°C 0-50°C(c) 0-50°C	10 x 10 <sup>4</sup> 28 x 10 <sup>4</sup> *43 x 10 <sup>4</sup>	8,192 x 60 16,384 x 56 *16,384 x 56	\$0.12		\$0.12	One core/bit One core/bit *One core/bit
0.37 x 10 <sup>4</sup> 0.75 x 10 <sup>4</sup> *1.5 x 10 <sup>4</sup> *0.30 x 10 <sup>4</sup> **0.50 x 10 <sup>4</sup>	5.4 x 10 <sup>-3</sup> 2.7 x 10 <sup>-3</sup> *2.0 x 10 <sup>-3</sup> **2.0 x 10 <sup>-3</sup> **3.0 x 10 <sup>-3</sup>	9.6 x 10 <sup>-5</sup> 7.2 x 10 <sup>-5</sup> *5 x 10 <sup>-5</sup>	(e) (e) (e)	*** *** *** *** ***	65-85°F 65-85°F 65-85°F	37 x 10 <sup>4</sup> 56 x 10 <sup>4</sup> *112 x 10 <sup>4</sup>	8,192 x 56 16,384 x 56 1,024 x 72 **1,024 x 40	\$0.38		\$0.28	One core/bit One core/bit *One core/bit Two cores/bit Two cores/bit
*0.2 x 10 <sup>4</sup> *0.25 x 10 <sup>4</sup>	*6.9 x 10 <sup>-3</sup> **6 x 10 <sup>-3</sup>			*** ***	*0-50°C *-70 to +150°C		*50k bits **32 x 36			**\$1.0-1.5 **\$0.50-1.25	
1.4-2.4 x 10 <sup>4</sup> *0.2 x 10 <sup>4</sup> *0.2 x 10 <sup>4</sup>	1.6-2.8 x 10 <sup>4</sup> *1.3 x 10 <sup>4</sup> *1.3 x 10 <sup>4</sup>	2.0 x 10 <sup>-5</sup>	(e) (e) (e)	*** *** ***	0-50°C(c) *0-50°C(c) *0-50°C(c)		8,192 x 56 *1,024 x 45 *16,384 x 56 8,192 x 56	*\$0.12		*0.35	Linear magnetic elements
	Read 2 MCS 3-6 mw/bit Write 33KC 3 mw/bit	5 x 10 <sup>-3</sup>	(k)	***	0-50°C	Read 96 x 10 <sup>4</sup> Write 16 x 10 <sup>4</sup>	2 <sup>16</sup> words 48 bits				Element heating insignificant

interrelated



(f) Based on quantity of one in maximum capacity and no optional features. Cost are subject to negotiation for large quantities.

(g) Magnetic assembly only including cores and switch diodes.

(h) Overall memory based on maximum capacity.

(i) Core plane only in small quantities.

(j) Complete read cycle only.

(k) Non operating vibration 10 to 33 cps at .020 amplitude for 30 mins above each axis. Shock—2 blows along each major axes of 15 g at 11 milliseconds.

characteristic.  
based on supplier announcements, but not known to have been built into a memory.  
resistance to nuclear radiation is limited only by associated semi-conductors.

FAMILY	DEVICE	DEVICE SWITCHING TIME ( $\mu$ SEC)	TYPE OF ACCESS	READ ONLY ( $\mu$ SEC)	WRITE ONLY $\mu$ SEC	READ WRITE CYCLE ( $\mu$ SEC)	STORAGE DENSITY(g) (BITS/CU. FT.)	POWER CONSUMPTION(h) (WATTS/BIT)	WEIGHT (LBS/BIT)
Ferro-Magnetic	Wire Memory Wire (f) Woven Screen	0.15	Random	0.1 0.15 (a) to 1 (b)	0.2 (a) to 1 (b)	1.0 0.5 to 1.0 (a) 3-10 (e)	$3.5 \times 10^6$	$2 \times 10^{-6}$ (c)	$4 \times 10^{-6}$ (c)
	Rod Thin Film Twistor	10-25 nsec 10 nsec 1.6	Random Random Random	50 nsec 25-50 nsec 1	50 nsec 25-50 nsec 5	0.1-0.2 0.05-0.1 5	$7 \times 10^6$ $31 \times 10^4$	$6 \times 10^{-3}$	$5 \times 10^{-3}$
	Drums 4096-42 bit words 175,000-36 bit words 400,000-36 bit words		Sequential Sequential Sequential			ave. access 2.5-8 ms 17 ms 180 ms	$1.75 \times 10^5$ $3.3 \times 10^5$ $4 \times 10^5$		$1.4 \times 10^{-4}$ $4.7 \times 10^{-5}$
	Discs 3,000-36 bit words 1024-36 bit words 15,000-36 bit words $3 \times 10^4$ -36 bit words		Sequential Sequential Sequential Sequential			3.7 ms 3.9 ms 8 ms 250 ms (max)	$1.9 \times 10^5$ $2.5 \times 10^5$ $7 \times 10^5$	$4.2 \times 10^{-4}$ $10^{-3}$ $4 \times 10^{-5}$	$0.4 \times 10^{-3}$ $2 \times 10^{-4}$ $1.4 \times 10^{-4}$ $3.3 \times 10^{-5}$
Hybrid (Ferrite-film)	Waffle		Random			0.4	$5 \times 10^4$		

**OTHER MEMORY SYSTEM**

Cryogenics	Sheet Film		Random			0-20	$10^4$		
Semi-conductor	Tunnel Diode	0.1 ns	Random			10 ns	$2 \times 10^4$	1-4 mw	$5 \times 10^{-4}$
Acoustic	Magnetostrictive		Sequential				$1.7 \times 10^4$		

\* READ, WRITE AND CYCLE times, as well as Maximum Capacity are indicative of the state-of-the-art and are NOT interrelated

(a) linear select mode  
(b) coincident current mode  
(c) for a gigabit memory

(d) limited by semiconductors  
(e) 10  $\mu$ sec for 10<sup>7</sup> bit memory  
(f) 10 bits/inch



Table V. Magnetic Memory Systems\*

STORAGE DENSITY(g) (BITS/CU. FT.)	POWER CONSUMPTION(h) (WATTS/BIT)	WEIGHT (LBS/BIT)	SHOCK AND VIBRATION	RESISTANCE TO NUCLEAR RADIATION	OPERATING RANGE	RATE (BITS/SEC)	MAXIMUM CAPACITY	APPROXIMATE COST MEMORY SYSTEM/BIT(!)			REMARKS
								'60-'62	'63	'66	
3.5 x 10 <sup>6</sup> 7 x 10 <sup>6</sup> 31 x 10 <sup>4</sup>	2 x 10 <sup>-4</sup> (c)  6 x 10 <sup>-3</sup>	4 x 10 <sup>-4</sup> (c)  5 x 10 <sup>-3</sup>	Excellent	Excellent	-55°C to +100°C to +100°C(d)  -55°C. +150°C -55°C. +100°C	7 x 10 <sup>4</sup> (c)  10 <sup>6</sup>	Gigabits 10 <sup>5</sup> -10 <sup>8</sup>  Megabits Gigabits	\$10.00	10¢	0.1 to 0.3¢	4.5 x 10 <sup>6</sup> bits/module 6.5 x 10 <sup>4</sup> bits/plane (for 10 μsec cycle time)
1.75 x 10 <sup>5</sup> 3.3 x 10 <sup>5</sup> 4 x 10 <sup>5</sup>		1.4 x 10 <sup>-4</sup> 4.7 x 10 <sup>-5</sup>	Fair Fair Fair	Excellent Excellent Excellent	Good Poor Good	125-400 x 10 <sup>3</sup> 220 x 10 <sup>3</sup> 250 x 10 <sup>3</sup>	1.75 x 10 <sup>5</sup> 6 x 10 <sup>6</sup> 15 x 10 <sup>6</sup>	\$0.02 \$0.005 \$0.002			
1.9 x 10 <sup>5</sup> 2.5 x 10 <sup>5</sup> 7 x 10 <sup>5</sup>	4.2 x 10 <sup>-4</sup> 10 <sup>-3</sup> 4 x 10 <sup>-3</sup>	0.4 x 10 <sup>-3</sup> 2 x 10 <sup>-4</sup> 1.4 x 10 <sup>-4</sup> 3.3 x 10 <sup>-5</sup>	Excellent Excellent Excellent Poor		Good Good Good Good	150-400 x 10 <sup>3</sup> 140 x 10 <sup>3</sup> 300 x 10 <sup>3</sup> 160-400 x 10 <sup>3</sup>	0.1 x 10 <sup>6</sup> 4 x 10 <sup>4</sup> .5 x 10 <sup>4</sup> 75 x 10 <sup>4</sup>	\$0.033 \$0.013			
5 x 10 <sup>4</sup>											

OTHER MEMORY SYSTEMS

10 <sup>4</sup>			Good	Excellent	Good		10 <sup>7</sup> -10 <sup>9</sup>		
2 x 10 <sup>4</sup>	1-4 mw	5 x 10 <sup>-4</sup>	Good	10 <sup>17</sup> NVT	-65°C to +100				512-15 bit words
1.7 x 10 <sup>4</sup>			Fair	Excellent	-50°C +80°C	10 <sup>4</sup>	6 x 10 <sup>3</sup>	\$0.05	

related



Table VI. Magnetic Tapes and Digital Transport Systems

FUNCTION	CHARACTERISTICS	TECHNOLOGY					
		T'L	TRL	DCTL	MECL	DTL	
HALF ADDER	1. Number of Active Elements	4	9	6	8	4 DTL Nand Gates thus 4 Transis.	
	2. Number of Passive Elements	2	6	3	8	15 Diodes 8 Resistors	
	3. Propagation Delay - Max (NS)	Sum	10		30	5	25 NS
		Carry	10	2	15	3.5	
	4. Power Dissipation	12 MW	45 MW	45 MW	70 MW	10 mw/trans. 40 total with 6.0V supply	
	5. Gate (Logic) Input Current	0.2mA Max	0.20 mA	.3 mA	75 $\mu$ A	1.3 mA	
	6. Available Output Driving Current (mA)	6 mA 0.4V Vce	1.5 mA	3 mA	20 mA	10 mA	
	7. Voltage Levels (volts)	F 0.4 T 0.4	0.3 and 1.5	.5 to .8	0.8 V Logic Swing	Power Supply +6V: 1 State 2V 0 State 0.4V	
	8. Noise Sensitivity (Tolerable Noise Voltage on Logic and Power Supply Lines)	200 mV	0.5V on Logic 1.0V on Supply	50 mV	300 mV 400 mV max	0.8 V	
	9. Approximate Cost/Circuit	\$70	\$60 per 1/2 Adder. Slower Ones Cheaper	\$25-70	\$68	\$48	
	10. List the two Most Critical Parameters with Selected Circuit Technology	Inverse Alpha Col.	1. No. of Cascade Stages 2. Capacitance	V <sub>ce</sub> V <sub>cc</sub> Coll. Sat. Res.	Resistor Ratios	Resistor Tol. Saturation Res.	
11. General Comments	Figure of Merit 250 Pico-Watt- Seconds	Non- Inverting Gate		Mechanize s, c s, c simultane- ously	No tight tol. on junction fwd. voltages & currents		
GENERAL	12. Approximate Practical Number of Integrated Components/Chip Present (1963)	10	100 on 70 x 200 mil chip	10-15 T 15-20 R	Approx. 40 components/ chip	8 DTL Nand Gates (99 ckt. elements)	
	13. Anticipated Number of Integrated Components/Chip (1967)	50	200 on 70x 200 MH. Chip	100		100 Gates (900 ckt. elements)	
	14. Anticipated Cost 1967	\$4 to \$10	\$10 per Half Adder	50¢ per component	\$3.00		

T'L—Transistor Coupled Logic, TRL—Transistor Resistor Logic, DCTL—Direct Coupled Transistor Logic, MECL—Current Mode Logic.

DTL—Diode Transistor Logic

## D. MASS STORAGE

The term "mass storage" refers to a storage device, external to the computer, that can provide a large capacity and fast semirandom access. It is assumed that the device is under direct on-line control of the computer, that it is addressable by the computer but not necessarily by individual word, and that the information it stores is erasable and reusable.

The term "external" is used to differentiate the mass memory from the main, relatively high-speed internal memory of the machine. To qualify as "mass storage," the memory is expected to provide storage capacity in excess of  $10^7$  bits.

Mass memories provide semirandom access in the sense that relatively fast access can be made from any location to any other randomly chosen location without directly passing over all of the intervening records.

### 1. TYPES OF MASS STORAGE

Mass memories can be divided into two major categories: rotational, or translational types which involve a moving magnetic surface; and stationary types. Table VII summarizes the characteristics of the various memories.

### 2. MASS MEMORY APPLICATIONS

The intensive development efforts in mass memories have been initiated and sustained by a definite need in business, science, and military applications. A summary of such possible applications is shown in Table VIII.

### 3. MASS MEMORY ADVANTAGES AND DISADVANTAGES

Table IX summarizes the advantages and disadvantages offered by mass memories. Also included are the effects of such advantages and disadvantages on the choice of a particular type of mass memory for specific applications.

### 4. SUMMATION

It is predicted that the moving-media-type devices will continue to dominate the mass-memory field at least through 1970, but that the non-mechanical techniques providing faster access times will gradually come into wider usage as the cost is decreased and the capacity increased.

Table VII. Summary of Characteristics of Mass Memories

Type of Device	On-Line Capacity (Characters)	Cost per Character	Average Access Time	Data Transfer Rate in Ch/sec	Removable Media	Multiple Access Capability	Major Advantages	Major Disadvantages
Magnetic Tape Loop				20,000 to 100,000	yes	no	Low cost	Very slow access
Large Fixed-Head Mag. Drums	0.2 x 10 <sup>6</sup> to 1.0 x 10 <sup>6</sup>		15 msec	100,000 to 200,000	no	Possible	Fast access	High cost, low capacity
Moving-Head Magnetic Drums	4.0 x 10 <sup>6</sup> to 65 x 10 <sup>6</sup>		150 msec	50,000 to 150,000	no	no	Large capacity, low cost	Medium speed access
Fixed-Head Magnetic Disc File	10 x 10 <sup>6</sup> to 25 x 10 <sup>6</sup>		20 msec	100,000 to 350,000	no	Possible	Fast access	High cost
1 Dimension Moving-Head Mag. Disc	10 x 10 <sup>6</sup> to 100 x 10 <sup>6</sup>		100 msec	100,000 to 400,000	no	Possible	Large capacity, low cost	Medium speed access
2 Dimension Moving-Head Mag. Disc	10 x 10 <sup>6</sup> to 100 x 10 <sup>6</sup>		500 msec	50,000 to 100,000	no	no	Large capacity, low cost	Slow access
Removable-Stack Disc Files	2.0 x 10 <sup>6</sup>		150 msec	60,000	yes	no but possible	Large off-line capacity, low cost	Small on-line capacity
Magnetic-Card Files	5.5 x 10 <sup>6</sup>		200 msec	100,000	yes	no	Large off-line cap., low cost, discrete card	Small on-line capacity
Woven Screen Memory	1.0 x 10 <sup>6</sup> to 10 x 10 <sup>6</sup> (in future)		10 μsec (in future)		no	no	Fast access, non-mechanical	High cost, not currently available

Prepared by L. C. Hobbs, Hobbs Associates

Table VII. Summary of Characteristics of Mass Memories (continued)

	RPM	Type	Avg. Access Time	Capacity in Bits per Unit	Data Trans. Rate	Approx. Price per Unit	Presently Available
Bryant 4000	900	Disc	100ms	$720 \times 10^6$	400,000 ch/sec	?	Yes
Data Products f-5020	1,200	Disc	225ms	$155 \times 10^6$	?	\$100,000	Yes
Analex	?	Disc	?	?	?	?	No
IBM 1301	1,800	Disc	160ms	$168 \times 10^6$	90,000 ch/sec	?	Yes
IBM 1311	1,400	Disc	170ms	$2 \times 10^6$	78,000 ch/sec	\$ 30,000	Yes
NCR CRAN		Card	200ms	$33 \times 10^6$	100,000 ch/sec	\$ 50,000	Yes
Rem Rand FASTRAND	870	Drum	92ms	$390 \times 10^6$	150,000 ch/sec	\$160,000	Yes
Librascope Fixed Head Mass Memory	900	Disc	25ms	$120 \times 10^6$	350,000 ch/sec	\$300,000	Yes
Burroughs Fixed Head Mass Memory	1,500	Disc	20ms	$57 \times 10^6$	264,000 ch/sec	?	Yes

Prepared by L. C. Hobbs, Hobbs Associates

Table VII. Summary of Characteristics of Mass Memories (continued)

Type of Mass Memory	Major Manufacturer	Major Advantage	Major Disadvantage	Approximate Price Range
Tape Loops	Burroughs	Low cost, High Capacity	Slow Access	?
Tape Carousel	North American	Low cost,	Slow Access	?
Large Fixed Head Mag. Drums	Remington Rand LFE Bryant	Fast Access	High Cost	\$100,000 to \$200,000
Moving Head Mag. Drums	Remington Rand	Fast Access	High Cost	\$100,000 to \$150,000
Magnetic Card Files	NCR Magnavox	Discrete Removable Records	Low On-Line Capacity	\$30,000 to \$100,000
Magnetic Disc Files	IBM Bryant Data Products Librascope Burroughs	High Capacity Low Cost	Slower Access	\$50,000 to \$500,000
Film Storage	IBM Eastman Magnavox	High Density, Digital Coding Not Required	Not Erasable Slow Access	?

Prepared by L. C. Hobbs, Hobbs Associates

Table VIII. Mass-Memory Applications

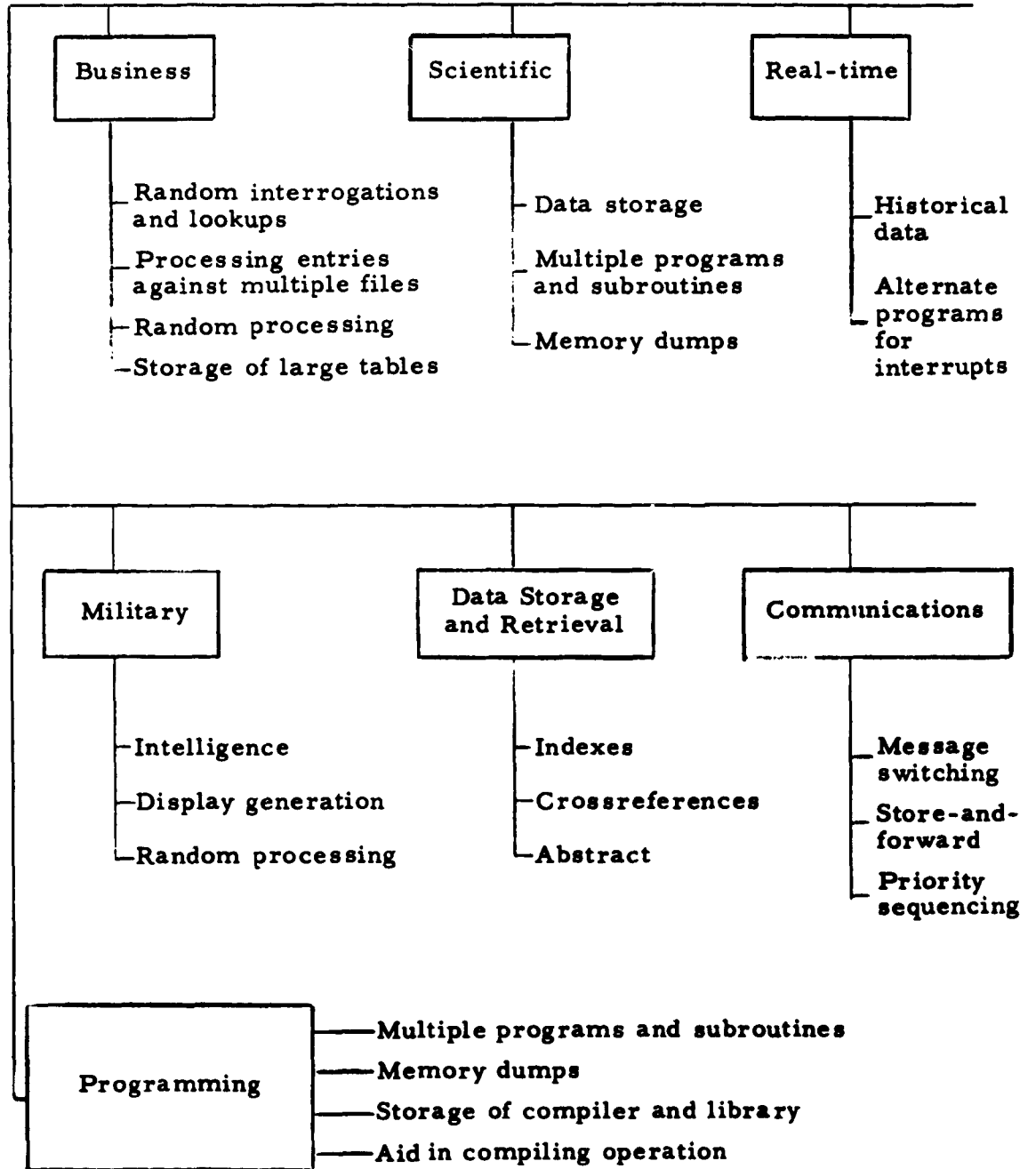

Prepared by L. C. Hobbs, Hobbs Associates

Table IX. The Effect of the Advantages and Disadvantages of Different Mass Memories on the Choice of Types for Specific Applications

TYPE OF MASS MEMORY	ADVANTAGES	DISADVANTAGES
Fixed-Head Magnetic Drums	Fast access, no mechanical head motion, high continuous data transfer rate	Low capacity, high cost per bit, poorer volumetric efficiency, large electronic switching matrix, large number of heads
Moving-Head Magnetic Drums	Large capacity, low cost per bit, possibility of parallel reading or writing from multiple heads to greatly increase instantaneous data transfer rate	Poorer volumetric efficiency, relative large number of heads for medium speed access or slower access if fewer heads
Fixed-Head Magnetic Discs	Fast access, medium capacity, no mechanical head matrix, high continuous data transfer rate	High cost per bit of storage, large electronic switching matrix, large number of heads
Two-dimension Moving-Head Magnetic Discs	Large capacity, minimum number of heads, low cost per bit	More complex positioning mechanism, slowest access, slow continuous data transfer rate
One-dimension Moving-Head Magnetic Discs	Large capacity, possibility of multiple simultaneous accesses if heads are positioned independently, low cost per bit compared to fixed head units, possibility of parallel reading or writing from multiple heads to greatly increase instantaneous data transfer rate	Relatively large number of heads, somewhat higher cost per bit compared to two-dimension disc unit, medium speed access
Removable-Stack Discs	Large off-line capacity, low cost per bit of off-line storage, combines on-line random-access capability with large off-line capacity	Limited on-line capacity, higher cost per bit of on-line storage
Magnetic Card Memory	Large off-line capacity, low cost per bit of off-line storage, combines on-line random-access capability with large off-line capacity, individual cards can be copied, replaced or inserted	Limited on-line capacity, higher cost per bit of on-line storage
Woven Memory	Faster access, no mechanical motion	Lower capacity, Higher cost per bit, not currently available

In selecting a mass memory for a particular application, it would be necessary to use the advantages and disadvantages listed above to select the types of mass memory best suited to the particular application. It would then be necessary to compare the detailed characteristics of these types and relate these detailed characteristics to the specific requirements of the problem.

Prepared by L. C. Hobbs, Hobbs Associates

## E. COMPUTER ORGANIZATIONS

To keep pace with advanced military electronic system requirements allied to aero and aqua-space explorations, consistent demands are made for increased computer speeds. The extrapolation of such demands suggests that a completely new family of ultrafast computers must be developed, rather than parallel a multitude of comparatively slow machines (such as the STRETCH, LARC, MUSE, MARK VI, ILLINOIS, CDC-3600 -- see Supplement A). With such computer systems, a bit transfer time of the order of 1 nsec (hence the term "nanosecond" or "gigacycle" computers) and memory cycle times of 10 nsec are suggested as representative figures of merit. With conventional computer organizations, device switching times of the order of 0.1 nsec would be required.

However, the advent of logic networks with nanosecond operating times does not necessarily herald the birth of a gigacycle computer. Although the devices are now available that will switch in 0.1 nsec or less, logic circuits employing such devices have stage delays several orders of magnitude larger than this. Moreover, they operate at repetition rates of only a few hundred megacycles.

Propagation delay, power dissipation, mechanism of resetting a circuit to its initial state after a logic operation has been performed, etc., are but a few of the factors that limit performance. In particular, timing tolerances are most important in nanosecond logic circuitry, because as pulses become narrower and poorly defined, the simultaneous arrival of input signals at logic gates assumes the dimensions of a probability. Thus, the circuit and its organization, rather than the device, seem to be restricting the speed attainable with current nanosecond logic circuits. It also becomes imperative to combine such logic circuits with a correspondingly fast memory in order to take full advantage of the speed increase in a computer. The required memory speed is defined by the functional speeds of the logic circuits, rather than the switching time or delay time. Also considering both the maximum speed and overall economy, it becomes desirable to limit the size of extremely high speed memories.

For circuits having logic level delays of a few nanoseconds, the design of the circuits cannot be separated from the design of the interconnecting line and package topologies. The electromagnetic energy associated with the transmission leads presents severe problems. The interconnecting signal leads assume the role of transmission lines and allied to this are all the problems of transmission line reflections, ringing, and matching. Packaging considerations must minimize delay and eliminate the crosstalk due to the fast pulse rise time. Also, circuit modules must be capable of driving the low impedance interconnecting transmission lines. Power dissipation and switching levels must be kept low to permit a high density package. Integrated-circuit technology will contribute considerably towards the mitigation of such effects but will offer no solution for them.

The brief discussion above serves to indicate that the nanosecond speed challenge cannot be met merely by using nanosecond components and circuitry in conventionally organized computers. A more promising approach is to implement novel organizational schemes in such a way that effective system operating speeds in the nanosecond domain can be achieved in spite of the limitations inherent in even the fastest components and circuits.

For example, consider a 10,000-word memory having an access time of 6 microseconds. Searching this memory to retrieve a certain word stored in it will take at least 60 milliseconds (worst case), using conventional methods. However, by organizing a memory so that its entire content is addressed simultaneously (see Paragraph E. 2. a.) it would be possible to retrieve the word in less than 12 microseconds. It follows, then, that 12-microsecond word retrieval in a conventionally organized computer would require an access time of 1.2 nanoseconds. Such an access time cannot be attained with the present state of the art or even in the foreseeable future. Thus, by combining novel memory organization schemes with the fastest foreseeable components, the problem-solving speed of computers in certain critical operations can be increased by factors of the order of  $10^3$  to  $10^9$  (see Section E. 2.).

Because such organizations have "affinity" or "love" for the nanosecond domain, they will be referred to as "nanophile" organizations. The most common of these are in the hierarchy of memory organizations. Of the wide gamut of such organizations that are being considered within the computer industry, the more notable will be discussed.

#### 1. "SCRATCHPAD" TECHNIQUES

Speed and economy considerations for a computer system impose limitations on the size of the extremely high speed memories. For example: the cost of complete memory systems employing techniques that yield access times in the region of 10 nanoseconds currently average about \$5.00 to \$10.00 per bit, depending on size. The capacity of such memories is limited to well below the megabit range. In contrast to these high speeds, the typical modern fast core memory achieves a cycle time between 1 and 5  $\mu$ sec with capacities of many megabits. The corresponding cost of these memory systems is presently in the neighborhood of 10 to 25 cents per bit. It would appear, then, that the practical size limits imposed on these systems will severely restrict the effectiveness of nanosecond computer circuit arrays. Several techniques have been devised to increase system speeds by extending the usefulness of small but extremely fast memories.

The arithmetic unit of a computer generally obtains its program and operands from the fastest memory system. However, it is a tedious and time-consuming procedure to move information sequentially from the slower storage media to that from which it is ultimately used. Consequently, techniques must be developed to retrieve new data at the same time that previously obtained data is being operated on. These techniques range from card to tape transcribers through magnetic tape searching and buffering devices and up to the various "lookahead" systems employed in core memories. Even with the use of these methods, the movement of the data between the various storage media represents considerable programming burden and is a very time-consuming process.

The most common method of achieving faster operational speeds is to dedicate a small fraction of the main random access memory as a "scratchpad" for certain kinds of operations. Operating at speeds 5 to

10 times that of the main memory, scratchpads are essentially extensions of the register capacity of the computer. They are used for index words, automatic interrupt addresses, intermediate computational results, and for commonly used constants or formats. Until recently, scratchpad size and speeds have not been adequate to execute all of the main program or subroutines.

Common practice, at any rate, assures us that a fast memory can be used in conjunction with a larger, but slower, memory "file" to provide an overall effective increase in memory speed. The apparent speed increase is proportional to both the speed of the scratchpad memory and the frequency of usage. Thus, increasing the relative frequency of scratchpad use can be most rewarding.

Implementation of simple scratchpad techniques requires the use of fast storage elements. In many instances those elements that are capable of being read nondestructively are preferred.

Scratchpads employing pattern recognition search techniques appear most promising for increasing the relative frequency of scratchpad use and for realizing nanophile organizations.

## 2. PATTERN RECOGNITION SEARCH TECHNIQUES

Recently developed pattern recognition search techniques offer a capability of considerable consequence in data processing. The technique was suggested by Dudley A. Buck as early as 1955 in what he called a "Recognition Unit." Contemporary workers investigated this type of memory under such names as Catalog Memory, Tag Memory, Data Addressed Memory, Search Memory, Associative Memory, and Content Addressable Memory.

The object of a Recognition Memory is to recognize the existence of a word (or bit patterns) in the memory, and to select and retrieve it on the basis of a key transmitted simultaneously to all words in the memory. In a true Content Addressable Memory (CA-memory), the key may be the stored word (or pattern) or any number of bits selected from any portion of the stored word (or pattern). Upon recognition of the key, either the whole word (or any part of it), or the address at which this word is stored, may be retrieved nondestructively.

In a true Associative Content Addressable Memory (ACA-memory), or simply Associative Memory, a CA-memory organization is used in conjunction with a conventional memory array. Only CA-memory word bits -- any or all of them -- can be used in the formation of a key. If a key is recognized, the information in the conventional memory associated with the CA-memory word may be retrieved nondestructively, including or excluding the information stored in the CA-memory. (It is to be noted though that a key can also be a discrete pattern such as a character or a continuous pattern such as a spectrum.)

Such memories are to be contrasted with conventional random access memories in which data is called forth from memory in terms of its address or storage location.

Of course not all computer operations involve a search of the entire memory. Many problems require access to a specific known memory cell. However, file search and correlative problems constitute a major class of computer operations.

The recognition technique discussed here permits the memory to compare the data in the search register with every single word stored in a CA-memory during one memory cycle. In doing so, it performs the equivalent of the many thousands of load and compare operations that would be required with a conventional memory organization.

It thus becomes apparent that it is possible to execute, say, correlation processes simply by comparing each word (or pattern) with all stored words (or patterns) rather than sequentially comparing with each stored word. Thus, if  $n$  words are stored and it is required to execute  $n$  correlations, the execution time in the case of the conventional sequential computing process will be proportional to  $n^2$ ; whereas with a CA-memory type organization, the execution time will be proportional to  $n$ .

To illustrate the recognition technique for a nanophile organization, consider a conventional core memory (access time in microseconds) employed to correlate 500 radar returns with 500 stored radar tracks. With such a memory, the time required to execute such a correlation process is in the tens of seconds. A CA-memory organization,

employing the same type of comparatively slow storage elements, can handle the same number of returns in tens of milliseconds. If faster storage elements are used (magnetic thin films, cryotrons, or tunnel diodes), the handling time can be further reduced to tens of microseconds.

In addition to pure correlation processes, recognition techniques are particularly useful in processes requiring the ordering of data such as in sorting, cataloging, compiling, retrieving, translating, and cross-indexing.

a. The Content-Addressable Memory

In a content-addressable type memory, the objective is to locate or secure information, or both, from file in absence of knowledge of physical address and without resort to sequential search. The information sought is related to whether the word, recognized by a key selected from any portion of it by suitable masking of the search register, is stored in the CA-memory. If it is found that the word is stored in the memory, it is then possible to read out nondestructively any portion of it or address of the location where it is stored, or both. With such a memory, it becomes apparent that the word to be selected from store is distinguished from all other words in terms of its own information content, hence the term "content-addressable." Thus, for example, it can be determined within one access time if a specific word of information is stored in the CA-memory, and within an additional cycle time, what the address of that word is.

In a true content-addressable configuration, all words in file are simultaneously interrogated for identity with a key word. Such a search may result in no match, a single match, or in the general and commonplace case, in multiple matches. Multiple matches can be processed by a nonunique-to-unique "jump" type match commutator that permits the sequential retrieval, on successive searches, of every stored data word recognized by the search key, regardless of the number of "recognized" words that are stored in the memory. That is, all multiple matches are found simultaneously and a "jump" commutator selects all locations which satisfy the match conditions in numerical

order for transmittal to, for example, a computer. No additional readout delay is involved, regardless of the location of the selected word.

For example: consider a nonunique match case where the search key recognizes words 3, 718, and 4065, in a 4096-word CA-memory array. Upon interrogation of the memory, mismatch information (one bit) is stored on all word lines except 3, 718, and 4065. In a subsequent interrogation cycle, the commutator "jumps" to word 3 and a unique selection of word 3 occurs. When the word is read out, one bit of word 3 is temporarily altered so that in a subsequent automatic interrogation cycle, the commutator skips words 1 through 717 and "jumps" to word 718. The interrogation sequence is repeated (at the option of a program) until all match words are read out.

Thus, the CA-memory furnishes data on a strict equality basis (exact match). However, it can also be employed to execute greater-than, less-than, between-limits, maximum, minimum, and mixed-search interrogations. The greater-than and less-than interrogations determine all words that are greater-than and less-than a specified key word, respectively. The between-limits interrogation determines all words stored in the CA-memory that fall within a certain interval (defined by two key words), and involves two searches: a less-than followed by a greater-than search. For a given set of words stored in CA-memory, the word or words that possess a maximum or minimum value can be determined by a maximum or minimum search, respectively. Mixed-search interrogation involves combinations of independent interrogation operations, performed in sequence on each of the selected word-portions, with other bits masked (certain bits of the selected word portions may be masked, too, if so desired), and the result of the search retained until all of the specified word-portions are processed. The result is that only those words are selected in which all of the selected portions have met their specified criteria.

To illustrate with a hypothetical application of a CA-memory, consider a surveillance type of orbiting satellite, one of its functions being the detection of frequency emitters. Whenever a frequency emitter is detected, the frequency is measured (say, 9 bits) and stored

in a CA-memory together with its location, e. g., longitude (8 bits) and latitude (7 bits). Further, assume that it has been established that no more than 10,000 possible emitters can be detected at unidentified fixed locations (for simplicity, one emitter per location). Upon detection of a frequency emitter, a 24-bit key word is formed containing frequency and location data and the CA-memory is interrogated 1 cycle time. If the key word recognizes a stored word, an "exact-match" condition, it means that the frequency observed in that location was detected during an earlier orbit and duly stored and no storage of information is executed. However, if the key word does not recognize any of the stored words, the newly detected frequency and its location are stored in the CA-memory.

Should it be found that it is commonplace for several emitters in the monitored sites to change frequency between successive orbits, it becomes desirable to execute a site search whenever a no-match condition is noted, to avoid storage as well as transmission of redundant information. Thus, when a no-match is noted, the 9 frequency bits are masked in the search register so that the 15-bit key word now represents the longitude and latitude data. When the CA-memory is searched, a "match" condition will be stored on the line of the word recognized by the key. The mask can now be removed from the frequency bits so that they can be written into the "match" word line location replacing the outdated information already transmitted on a previous orbit. When the satellite becomes interrogated by the ground station, only the "matched type" words are transmitted, together with the new words added since the previous interrogation (now marked for transmission by an artificial match condition). Note that though the range of frequencies may be known, no physical address can be assigned to a frequency because it remains unknown until detected. Also, since 10,000 possible frequencies have been predicted, a 10,000-word CA-memory would be adequate.

The CA-memory can also be interrogated by the ground station to determine the locations where a certain known frequency was detected. The 9-bit key word represents the search frequency and the 15 location bits in the search register are now masked. When the memory is

interrogated, the longitude and latitude data of all stored words recognized by the key word can be read out nondestructively, yielding the desired information.

The ground station may desire to determine if any emitters were detected in a certain area defined, e. g., by longitudes  $L_{01}$ ,  $L_{02}$  ( $L_{01} > L_{02}$ ) and latitudes  $L_{a1}$ ,  $L_{a2}$  ( $L_{a1} > L_{a2}$ ) without resorting to a sequential search. Mixed between-limits searches can yield the desired information, thus:

If  $L_{01}$  is used as a less-than key (frequency and latitude bits being masked), all words recognized by a less-than search are noted as "match" words. If in addition to the less-than search, a greater-than search is performed with  $L_{02}$  as the key, then words previously recognized by  $L_{01}$  but not recognized by  $L_{02}$ , represent mismatches. The remaining match words represent longitudes equal or greater than  $L_{02}$ , but equal or less than  $L_{01}$ . These two search operations constitute a "between-limits search."

If the longitude and frequency bits are now masked, a between-limits search can also be performed in a like manner with  $L_{a1}$  and  $L_{a2}$  as the key words. Only those words recognized by the two between-limit searches are considered as match words; all other words represent mismatch conditions. With a mixed-search, the two independent between-limits search operations are combined and interrogation performed in sequence on each of the key words, with only the 9 frequency bits always masked.

b. Associative Content Addressable Memory (ACA Memory)

A random access, conventional memory array can be organized to incorporate, in a sense, certain decisions. For example, the word read out by conventional techniques would have the next address associated with it. Such associative properties have been observed and exploited in a limited manner. However, by allying the content addressable and associative properties, the development of a very powerful technique is evident which is attracting widespread attention for implementing future nanophile organizations.

In an associative content-addressable configuration or simply the "associative memory," the storage elements contain not only the desired information but also some key or label, the descriptor word, which identifies the data. The elements containing the word identification are so arranged as to allow a simultaneous content addressable search of a given descriptor word. With suitable mask-search techniques, any or all descriptor word bits can be used in the formation of a search key. The desired data is stored in a conventional memory array, and is associated with the CA-memory plane storing the descriptor words. If a search key recognizes a descriptor word in the memory, a signal is produced defining the physical location of that word so that the associated data word in the conventional memory may be subsequently read out by the conventional method.

Assume that for the example described in Paragraph E. 2. a, the descriptor word is formed by the frequency bits and that the latitude, longitude, and other information, totaling perhaps 30 bits, associated with the emitter are stored in a conventional word organized memory. Thus, the CA portion of the associative memory will contain the 9 frequency bits only. The 30 data bits associated with each frequency are stored in, say, a core memory. Suppose that among a multitude of frequencies detected during one orbital flight, three emanated from infrared emissions in the static testing of missiles. Suppose these three emissions, detected in three different locations, are stored in words p, q, and s (physical addresses unknown). Upon interrogation by a ground station for infrared emissions, the CA portion only is searched and "match" conditions will be stored on lines p, q, and s of the associative memory. The match commutator then selects, in sequence, the match words. For each word selected, the contents of the core memory are read out (destructively), yielding all the information collected for the specific missile test site. Note that in this case a destructive type readout will suffice.

An associative content-addressable scratchpad can be used to simplify the data relocation problem by eliminating the need for a new physical address. Data may be relocated into a scratchpad memory

and still maintain the original address of its location in a much larger system. Words are stored in random or nonordered locations in the scratchpad along with their original addresses.

For example, when a word is desired from storage, the content-addressable portion of the memory is searched simultaneously for a particular address. If it is present, a signal is produced which indicates the physical address of the word so that the data portion may be read out. If no locating signal is produced, the word is not contained in the scratchpad and the address is transferred to the main memory for readout in the normal fashion. This system greatly simplifies the addressing problem and allows the programmer to be much more selective in his choice of data to be stored in the scratchpad.

An alternative scheme often used with ACA memories is that of symbolic addressing. Using this method, data in the scratchpad are assigned names which have no relationship to addresses or locations in the storage media. This technique is advantageous in that it allows the compression of the associative address to a size representative of the scratchpad capacity rather than that of the main "file" memory.

### 3. TYPES OF RECOGNITION MEMORIES

#### a. Cryogenic Associative Content-Addressable Structures

Cryotron circuit techniques are particularly well suited to applications such as associative content addressable structures in which a close intimacy exists between logic and memory functions. Fully associative content addressable properties have been designed. Any field of the digits may be used for comparison purposes as determined by a mask word. When multiple matches occur, the matching words are read out in sequence with the aid of a cryotron ladder circuit. Selection and storage is achieved without the use of location addresses.

A number of memories have been designed, differing primarily in the criteria used for selecting records. The simplest design enables selection of the basis of equality between records and applied key. In another memory, the records selected are those lying between specified numerical limits. Work is proceeding on even more versatile designs in which more sophisticated selection criteria are used.

b. Tunnel Diode Content-Addressable Structures

A content-addressable configuration using one tunnel diode per bit has been constructed and tested. Its advantage is extreme speed. However, it is not economical to build except for small scratchpad applications. Also, very considerable sustaining current would be required, particularly if a design called for many words. Ten thousand 50-bit words for example would require 1000 amperes.

With a 256-word 38 bits/word tunnel diode structure, interrogation times of the order of 0.05  $\mu$ sec are possible, with readout times of the order of 25 nsec and write-in times of the order of 50 nsec.

c. Magnetic CA and ACA Structures

1. Thin Films

Magnetic thin films appear to be practical structures for fast intermediate capacity associative scratchpad applications. For a 128, 24-bit word structure for example, 100-nsec interrogation times have been predicted.

2. Magnetic Cores

Search plane functions can be implemented in a novel two-core-per-bit configuration of multiaperture (transfluxor) cores. However, except for the comparatively slow write-in time, BLAX elements are the most economical off-the-shelf items for associative structures.

Table X summarizes the performance characteristics for the various types of associative memories.

Table XI illustrates a set of specifications for a multi-aperture magnetic core associative content addressable memory.

In Table XII the general capabilities of associative memories are outlined.

The BLAX approach appears to be presently the best approach that can yield operational equipment within a year or so. Primary advantage is related to extremely high signal-to-noise ratio.

The TRW wire approach may offer an avenue for inexpensive associative mass memories.

Table X. Associative Memories (Performance Characteristics Given Are Intended to Illustrate Order of Magnitude)

	BIAX (TRW Approach)	Transfluxor	TRW Wire Approach	Continuous Sheet	Cross Film Cryotron	Male Bicore
1. Storage Element	Transverse field	NDRO at minor aperture	Transverse field	Authoritative figures presently unavailable	Authoritative figures presently unavailable	Authoritative figures presently unavailable
2. Interrogation Phenomena	very large	10-20	very large			
3. Element S/N	very large	3:1	very large			
4. Effective S/N						
5. Number of Elements/Bit of Information Stored	1	2	1			
6. Capacity-Bits Per Word	unlimited	<60	unlimited			
7. Retrieval Times (max)	12 $\mu$ sec	8 $\mu$ sec	12 $\mu$ sec			
8. Multiple Match Resolution Time: Exact Match	3 $\mu$ sec	3 $\mu$ sec	3 $\mu$ sec			
9. Cost/Bit	\$4.00 (30,000 bits)	\$6.00	\$3.50			
10. Cost/Word	\$240.00 (60 bit word)					
11. Cost/Sense Amplifier Unit	\$30.00	\$40.00				
12. Cost for Search Logic Unit	\$30,000.00	\$30,000.00	\$30,000.00			
13. Power Required	110V @12A (512 words 60 bits each)	110V @36A	110V @12A			

Table XI. Specification Summary for Multiaperture Magnetic Core Associative Content Addressable Memory

	<u>Functional</u>
Memory Capacity	1024 search words and 1024 data words
Word Length	12 bits search and 26 bits data
Write Cycle Time	6.0 microseconds
Search/Read Cycle Time	6.0 microseconds
Clear Cycle Time	6.0 microseconds
Search Mode	Nondestructive . All words and all bits in parallel
Data Read Mode	Destructive with automatic rewrite— All bits in parallel
Multimatch Capability	Included. Unlimited matches possible
Descriptor Field Masking	Any combination of search bits may be masked
<b>Search Times After Set-up of Criteria:</b>	
full word, exact match	about 6 $\mu$ sec
full word, greater than or equal match	about 12 $\mu$ sec
full word, less than or equal match	about 12 $\mu$ sec
between limits march	about 24 $\mu$ sec
mixed search:	
2 bytes specified:	
all exact match	about 6 $\mu$ sec
all inequality matches	about 9 $\mu$ sec
all between limits matches	about 15 $\mu$ sec

Table XII. Capabilities of Associative Memories

1. Read out
  - a. match-mismatch
  - b. location
  - c. data
  - d. combinations
  - e. multiple-match
2. Match Detection
  - a. active
  - b. passive
3. Loading
  - a. sequential from first location
  - b. sequential from any location
  - c. random
  - d. selective loading within a word (matching word or all words)
  - e. first-in-first-out
  - f. last-in-first-out
4. Built-in logical capabilities
  - a. exact match
  - b. greater than or equal to
  - c. less than or equal to
  - d. between limits
  - e. maximum
  - f. minimum
  - g. ordered retrieval
  - h. closest numerical match (next higher-next lower)
  - i. closest pattern match
  - j. masking
  - k. mixed searches (any combination of above on portions of the word)

#### 4. THE "VIRTUAL MEMORY" CONCEPT

An extension of the associative content-addressable (ACA) memory organization has been developed which attacks the problem of data selection and relocation. This system automatically relocates data words in the ACA scratchpad along with their appropriate addresses. When information in the scratchpad is no longer useful to the current problem, it is replaced with data and programs presently required. This method can theoretically achieve quite a high frequency rate for the scratchpad with a corresponding virtual increase in overall speed. It does this with no conscious effort on the part of the programmer.

In general operation, this system is quite similar to the ACA organization described before. Data is stored in a scratchpad data store, with corresponding addresses in the descriptor store. If an initial search locates the desired address, it is read out of the scratchpad data store; if not, it is obtained from the main memory file. The significant feature of this memory is that the data store is automatically filled with currently useful data.

To accomplish this, a control system should be provided to develop two criteria, namely: (a) when is a word important enough to be added to the scratchpad, and (b) when this occurs, which word should it replace? The first criteria can be readily developed by adopting a trial-and-error technique. It is assumed that all words obtained by the program are likely to be subsequently reused. Thus, if a desired word is not currently in the scratchpad and must be obtained from the main memory, that word replaces the least valuable word in the scratchpad. The problem then resolves into one of finding a criteria or a "weighing" technique for selecting the word to be replaced.

The practical aspects of this problem are twofold. First, what mathematical models can be used to determine the relative worth or probability of reuse of a given data word or instruction? Then, which of these models lends itself to economical implementation? A reasonable, simple model is one based on recentness or frequency, or both. A word used by the computer 5 operations ago is more likely to be used sooner than one used 5000 operations previously. Given two words that were last used at approximately the same time, the word

that has been more frequently used is more likely to be used again. The exact quantitative statement of this model requires considerable effort to determine the relative merits of recentness and frequency. It is also quite likely that the individual functions themselves are nonlinear. That is, a word used only 50 cycles ago may be much less than twice as valuable as one used 100 cycles ago. The determination of these models, which are quite informative, is somewhat academic when considered in relation to those models which can be economically implemented.

To implement the automatic loading feature, each word in the scratchpad must have associated with it a value function or weight. The control system must contain a means of sampling these functions or weights to determine the one which is sufficiently low to warrant replacement of its associated word by a recently obtained one. The value function or weight of a word is generally time-varying, the weight gradually decreases as other words are used and increases as the word itself is used. Depending upon the model used, the value function of many words changes at each operation. The implementation of a system to alter these weights is a considerable task. The second problem associated with this feature is the sampling of the weights to determine an appropriate low one. If there is a unique number for the lowest weight, e. g., zero, then this may be located by content-addressable searching techniques identical to those used to find addresses in the scratchpad memory. If the lowest value function is not unique, a useful technique is to quantize the values according to the properties of the number system. For example, if the value function is a three-decimal digit number, an adequate criteria for replacement might be that the higher two digits be zero. This quantification process loses resolution but certainly not disproportionately to the precision of the model used.

In order to illustrate the operation of such a memory, a simplified hypothetical system is described below. The system uses recentness only as the criterion for retention in the scratchpad. This model allows the assignment of unique weights to each word. The rank or ordering of the words in regard to recentness of use is only required. For example, we need not know that the 98th most recent word was used 174 cycles ago and that the 100th was used 192 cycles ago. All that is necessary is

the relative rank since, if the size of the memory is only 100 words, the 100th word is the next to be replaced. If a word is obtained from the scratchpad, its rank is changed to one, i. e., it becomes the most recently used word. All words up to the previous rank of the current word increase their rank by one. Thus, the last word used now becomes the second most recent and so on up to the previous rank of the current word. If the original rank was  $n$ , then the  $(n - 1)$  word becomes the  $n$ th and all ranks greater than  $n$  are unchanged. The problem of adjusting the value of the words in the memory becomes one of selectively counting a group of numbers. The size of this group varies with the rank of the currently obtained number, and its members are distributed randomly throughout the scratchpad. The implementation of this scheme is not necessarily the most advantageous or even economically feasible; there still remains a considerable area of compromise between the efficiency of theoretical models and ones which can be practically implemented.

As the problems relating to these systems are twofold, so are the approaches to the solution. First, what models realistically indicate the probability of a word's reuse and second, how can these models, or approximations of them, be implemented? In the interests of practicality and usefulness, it is appropriate to rephrase the first part of the problem. After a preliminary study of optimum theoretical models, it becomes more pertinent to ask what is the relative usefulness of a model which has been demonstrated feasible. This question may be answered by computer simulation techniques without the effort or expense of experimental memories. The latter part of the problem, namely implementation, can be best attacked by investigating devices used in the CA and high-speed memories. These devices can be arranged in a variety of networks, some of which exhibit interesting logical properties. It has already been demonstrated that logical functions of data stored in these networks can be generated almost as easily as the actual data. Further investigation of these properties may yield networks which provide adequate models of the value function.

The use of high-speed memory devices coupled with the techniques of associative addressing and automatic relocation will yield virtual

memory speeds far in excess of that expected from the use of a scratchpad memory alone. The properties of these memories also eliminate the programmer's preoccupation with the movement and reorganization of data, an economy which in itself may be a sufficient goal.

Thus, by having an ACA scratchpad act as a buffer between a computer and a relatively slow but very large data file, data can be accessed very rapidly by large file address tag from the associative memory, but appears to the computer to be drawn directly from the very large file at virtually scratchpad speeds.

#### 5. HOMOGENEOUS STORAGE CELL STRUCTURES WITH BUILT-IN LOGIC PROPERTIES (LOGISTORE CELLS)

The CA and ACA memory organizations discussed can be organized to incorporate, in a sense, certain logic properties. In an example cited earlier, the word "interrogated" may have the next address associated with it. In a broader sense, the logical capability that can be incorporated within each memory cell by suitable mask interrogation techniques can permit simultaneous associative decisions to be made throughout a memory structure. Consequently, computations can be performed simultaneously in any selected cells of the memory. This is different in several respects from parallel type operations performed in multiphase computers.

In a stricter sense, the topological aspects of CA configurations focus attention on the need to consider a homogeneous memory structure having cells with built-in-logic capabilities, for a given "input-output" set of cell connections.

#### 6. OPTICAL COMPUTERS

The fastest speed of communication between two distant elements of a computer is that of electromagnetic waves in vacuum. It is, therefore, natural to look for light applications in computer techniques because it combines speed with directionality. With the constant search for faster speeds, it is possible that many operations presently performed in computers by electronic components can be taken over by optical or electro-optical elements. For example, it has been suggested that semiconductor junction technology, when combined with

optical coupling between electroluminor and photoconductor components, promises to provide an iterative modular computer design oriented towards parallel processing of information along logically "biased" channels. Parallel processing is thus attained not through duplication but by communication among neighboring cells. The number of parallel operations possible is in the range of  $10^4 - 10^6$ . The number of switchings per second that can occur is in the range of  $10^5 - 10^7$ , thereby yielding a total figure of  $10^9 - 10^{13}$  operations per second. Optical information processing enables the simultaneous application of cellular or iterative logic with threshold logic. The first experimental implementation of this new approach of information handling is found in the synthetic "frog retina" developed by RCA.

Recent progress with solid-state lasers indicates that current progress toward an optical computer may be more rapid than many observers thought even a short time ago. Successful experiments in optical switching, using prisms made of birefringent materials as a medium for controlling the deflection angle of optical beams, is another indication of the rapid advance of technology in this area.

## 7. ANALOG-DIGITAL HYBRID ORGANIZATIONS

It is useful to consider systems that combine analog and digital techniques to achieve accuracies not possible in a strictly analog system and speeds not practical in a strictly digital system. Processing of photographic information provides an example of such a system.

Consider the TRW Automatic Map Compilation System. The problem is to accurately locate corresponding image points on two photographs taken from widely separated camera stations and to use this information to obtain an altitude map of the area as well as to produce a new photograph in which relief displacements and their distortions have been removed, i. e., an "orthophoto."

One might consider a system in which the photographic imagery is converted to digital form and stored for later access by a program designed to make the necessary correlations and coordinate transformations. However, the tremendous information store required for this purpose and the nature of the access problem make such a solution undesirable.

The design of the TRW Automatic Map Compilation System takes into account the fact that the original photograph is the finest possible storage device for the purpose. Appropriate analog circuitry, under command of a digital computer, provides ready access to any of this photographic information. Additional analog circuitry performs the required correlation to evaluate any height error and supplies corrections back to the digital system. The photographic information is transferred through the analog system to appropriate positions on the negative on which the orthophoto is being printed. The computer simultaneously provides appropriate altitude information to the analog system for use in printing out the altitude chart.

The system is capable of processing a stereo pair having a store equivalent to perhaps  $10^8$  words of 3 bits each ( $10^8$  resolvable elements with 8 shades of grey) in about half an hour.

If a digital computer were employed, a 4- $\mu$ sec cycle time memory having a 300-megabit capacity would be required, at an approximate cost of about 0.1 cent per bit. This cannot be attained by the present state of the art.

## 8. BLOCK TRANSFER TECHNIQUES

The movement of data between the various storage media represents considerable programming burden and is a time-consuming process. Little attention has been focused on the application of radio-frequency techniques utilizing nondestructive readout properties of a memory. Simultaneous interrogation can be performed by suitably programming a digital oscillator to generate the appropriate frequencies. These frequencies are then channeled to the word lines, the information being read out simultaneously along the digit lines. Passive, integrated filtering elements can be employed in channeling the oscillator frequencies and retrieving the information from the digit lines. Parametric storage devices "resonating" to the line frequency can also be considered.

## 9. MEMORY ORIENTED COMPUTERS

A combination of the memory structures described above and summarized in Table I can be utilized in a memory-organized computer.

Figure 5 serves as an example: the large file may be comprised of a magnetic thick film or cryogenic memory if in the megabit capacity. Multiaperture cores, cryotrons, thin films, and tunnel diodes, depending on the virtual speed sought, can be utilized for scratchpad associative structures. A tunnel diode memory array comprised of cells shown in Figure 2 and exhibiting a nondestructive readout capability can serve as a switchboard (experimental breadboards were tested up to 46 mc). Semiconductor, magnetic, and cryogenic devices can be used in storage-logic cell arrays. Works by Holland from the University of Michigan and McCormick from the University of Illinois have laid, in a sense, a foundation for the direction pursued by contemporary workers in this field.

## 10. PARALLEL PROCESSORS

Gains in computational efficiency are expected from systems with parallel computing capabilities. Two approaches have been significant:

### a. The UCLA Approach

A system is presently being investigated that has the ability to perform multistage parallel processing. It is capable of being reorganized to optimize the throughput time of any given problem, constrained by what is available at that time in its extendable hardware inventory.

### b. The Westinghouse Approach ("Solomon" Computer)

The SOLOMON (Simultaneous Operation Linked Ordinal Modular Network) is a parallel network computer involving the interconnections of many identical processing elements, as few or as many as a given problem requires. Programming is under the supervision of a central control unit, in an arrangement that can simulate directly the problem being solved.

## 11. SUMMATION

Recognition structures, such as the content-addressable and associative memories, can be organized in a manner that can offer effective system operating speeds in the nanosecond domain, in spite of limitations inherent in the fastest components and circuits. In certain

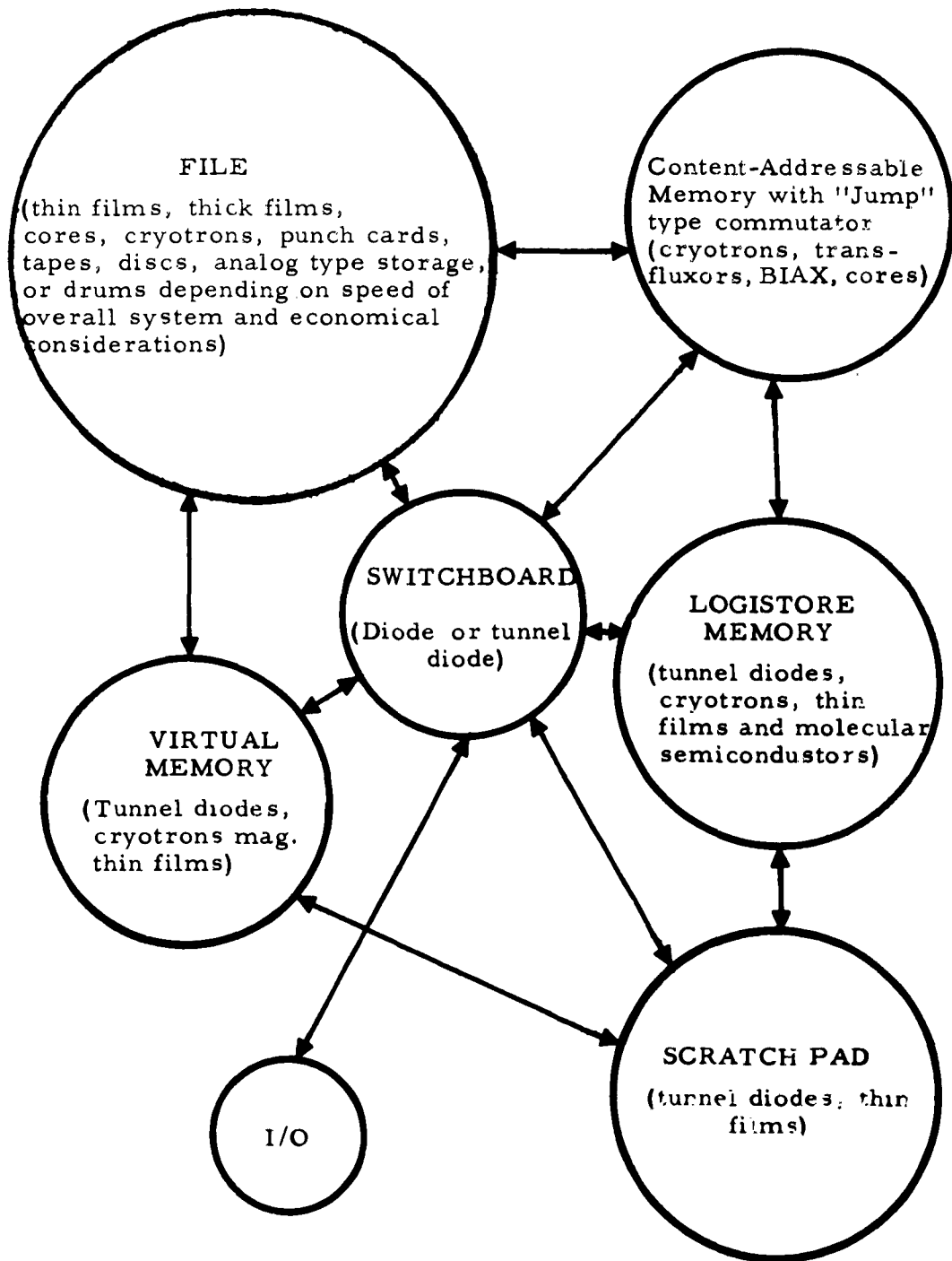

Figure 5. Memory-Oriented Computer—An Illustrative Example

problem-solving areas effective computer speeds can be increased by factors ranging from  $10^3$  to  $10^9$ .

Experimental recognition planes have been constructed employing integrated circuits, bicore, plated wires, multiaperture devices such as BIAx and MALE, and cryoelectric devices, such as continuous sheet and cross-film cryotrons. Available information related to characteristics and figures of merit is shown in Table X.

Three types of systems that employ recognition structures are possible.

a. Conventional Computer and Conventional Associative Memory

This concerns an associative memory system and its interface with a control computer.

b. Conventional Associative Memory and Oriented Computer

This concerns a control computer specifically designed to take full advantage of the power of the associative memory as shown by works of Rosen and Fuller.

c. Reorganized Associative Memory and Oriented Computer

This concerns approaches such as the Associative Computer by Davies. The Associative Computer is an outgrowth of Associative Memory, the latter being characterized by the property of possessing logical capability in each memory cell. This logic permits simultaneous associative decisions to be made throughout the memory. The Associative Computer has, in addition to these associative capabilities, the ability to perform computations simultaneously in any selected set of cells of the memory. Some of the advantages of this approach are the following:

- (a) Structural periodicity in all 3 dimensions to simplify thin film fabrication processes
- (b) Nearest neighbor communication to minimize inter-connection lengths and signal propagation delays
- (c) Simultaneous associative capabilities on such criteria as equality, greater than, less than, between limits

- (d) Simultaneous computational capability throughout memory
- (e) Flexibility in masking operands
- (f) Internally stored programs
- (g) No addresses.

The Associative Computer design can be mechanized from thin film cryotrons. These devices are particularly suitable for the application because of their small size, low cost, speed, and ability to perform logic functions as well as memory. The ability of a cryotron with near unity gain to drive an arbitrarily large number of other cryotrons (albeit at reduced speeds) permits the construction of iterated logical networks of a kind that are required in the Associative Computer. Furthermore, the low power dissipation of the cryotron is consistent with the requirement for distributed simultaneous computation.

The kinds of applications in which the special advantages of the Associative Computer can be most fully utilized are related to problems which are reducible to a form in which the same program is applied independently to a large number of sets of data, all following the same format.

## F. APPLICATIONS FOR RECOGNITION MEMORIES

The following represents a brief list of possible applications:

### 1. RADAR CORRELATION TECHNIQUES

If a conventional core memory with access time in microseconds is employed to correlate, say, 500 radar returns with 500 stored radar tracks, the time required to execute such a correlation process is of the order of tens of seconds. A CA-memory organization, employing the same type of comparatively slow storage elements, can handle the same number of returns in tens of milliseconds. It is true, though, that such time improvement can be obtained by employing special purpose, but comparatively uneconomical computers. If faster storage elements are used, such as magnetic thin films, cryotrons, or tunnel diodes, the handling time can be further reduced to tens of microseconds.

A TRW-130 or TRW-133 with a recognition memory can facilitate in situ radar correlation to implement pulse train separation techniques with particular reference to ELINT systems.

An illustrative command list for a 512-word 60-bit content addressable memory to operate with a TRW-130 computer is shown in Table XIII. Estimated Internal Execution times are given in Table XIV. The Control Word Format is shown in Table XV. The following searches are possible: exact match; greater-than or less-than; between-limits; maximum; minimum; nearest low value; nearest higher value; mixed searches. For example: for 2 bytes specified, all exact match -- 9  $\mu$ sec; all inequality matches -- 12  $\mu$ sec; all between limits matches -- 25  $\mu$ sec.

### 2. ASW TECHNIQUES

A recognition memory can be used with sonar (and other) tracking equipment in ASW systems. The approach could be analogous to radar track correlation techniques.

### 3. SURVEILLANCE TECHNIQUES FOR ORBITING SATELLITES

Because it is impossible to store all geographical locations in surveillance types of orbiting satellites, a recognition memory offers many degrees of freedom hitherto denied to a surveillance system designer.

Table XIII. Proposed Command List for 512-Word 60-Bit CAM  
to Operate with TRW-130 Computer

---

CLEAR MEMORY - Erase all data and tags.

CLEAR TAGS - Erase the tags specified in this command at all words.

LOAD DATA

- a) AT SPECIFIED LOCATION - Erase cell contents and write the following data words in successive cells starting at the address specified in this command.
- b) AT ANY VACANT CELL - Write the following data words successively at any vacant cells.

READ DATA (LOCATION ADDRESSED) - Transfer successively cell contents starting at the address specified in this command. Rewrite cell contents and tag per options specified in this command.

Rewrite Options:

1. Erase.
2. Tag and restore.
3. Modify, tag, and replace. (Modify per the following two data words which are mask and data, respectively.)

Tag Options:

1. Erase and/or mark specified tags.
2. Increment tag binary count. (7 counts limit)
3. Decrement tag binary count. (0 count limit)

SEARCH - Mark at the match store register the set of cells which satisfy this and previous contiguous search criteria. Criterion includes:  
1) Search operation (specified in this command); 2) Mask; and  
3) Search word.

Search Operations:

1. Exact match.
2. Greater than or equal.
3. Less than or equal.

Search Hold Options:

1. None (the next two data words are mask and search word respectively).
2. Retain this command. (Subsequent data words alternate mask, search word, mask, search word, etc.)
3. Retain the previous mask. The next data word is the search word.
4. Retain the previous search word. The next data word is the mask.

Table XIII. (Continued)

5. Retain this command and the previous mask. Subsequent data words are search words.
6. Retain this command and the previous search word. Subsequent data words are masks.
7. Retain the previous mask and search word.

Interrupt Options:

1. Interrupt on match.
2. Interrupt on no match.

SEARCH AND SHIFT MATCH - Same as Search (above) except provide match indications at the match store register such that all cells at next higher addresses from those cells which satisfy the search criteria/criterion are also match marked.

SHIFT MATCH - Alter "match" indications at the match store register so that all cells at next higher address from match marked cells are also match marked.

READ SEARCH RESULTS AND

- a) TRANSFER ADDRESSES - Transfer successively the addresses of all cells in the set which satisfy the just previous contiguous search criteria/criterion.
- b) TRANSFER DATA - Read and transfer successively the contents of all cells in the set which satisfy the just previous contiguous search criteria/criterion. Rewrite cell contents and tag per options specified in this command.
- c) MODIFY - Alter, per rewrite and tag options specified in this command, the contents of all cells which satisfy the just previous contiguous search criteria/criterion.

Rewrite Options:

1. Erase.
2. Tag and restore.
3. Modify, tag and replace. (Modify per the following two words which are mask and data, respectively.)

Tag Options:

1. Erase and/or mark specified tags.
2. Increment tag binary count. (7 counts limit)
3. Decrement tag binary count. (0 count limit)

Interrupt Options:

1. Interrupt on match.
2. Interrupt on no match.

Table XIV. CAM Commands Estimated Internal  
Execution Time

Note: All times are measured from clock in of the word completing information necessary to execute.

CAM Clock rate is 333 kc

1. Clear Memory	12 $\mu$ sec
2. Clear Tags	12 $\mu$ sec
3. Load Data at Specified Location	6 $\mu$ sec/word
4. Load Data at any Vacant Cell	9 $\mu$ sec/word
5. Read Data (Location Addressed)	12 $\mu$ sec/word
6. Search: Exact match	9 $\mu$ sec
Less or greater	15 $\mu$ sec
7. Search and Shift Match	12 to 18 $\mu$ sec
8. Shift Match	6 $\mu$ sec
9. Read Search Results and Transfer Addresses	3 $\mu$ sec/address
10. Read Search Results and Transfer Data	12 $\mu$ sec/word
11. Read Search Results and Modify	12 $\mu$ sec/word

Table XV. Control Word Format

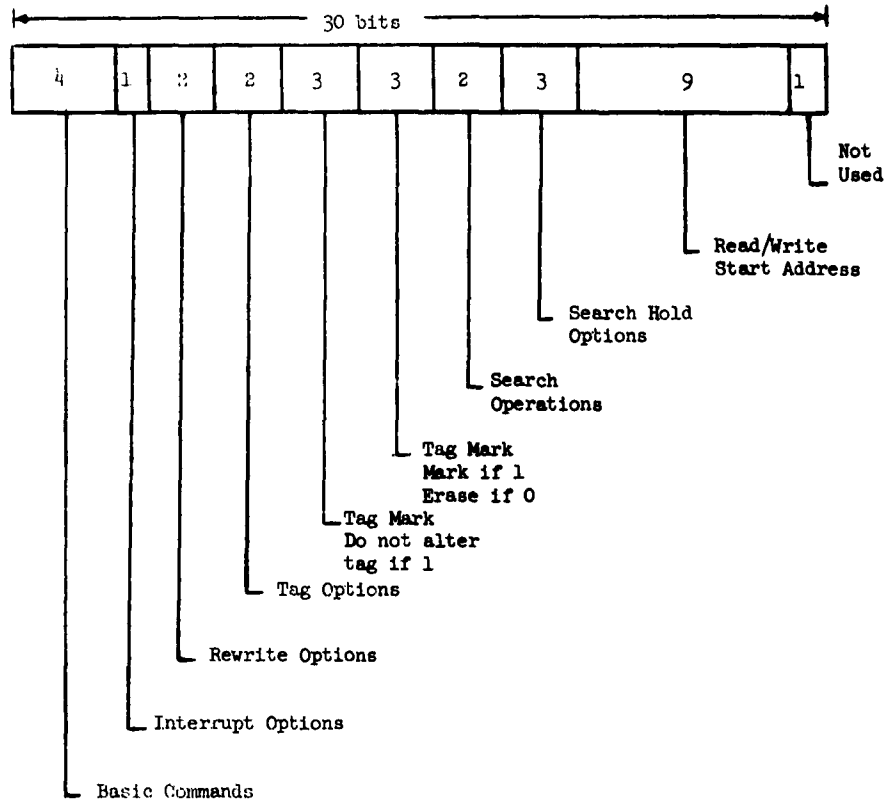

Data Mask \* and Search Word Formats

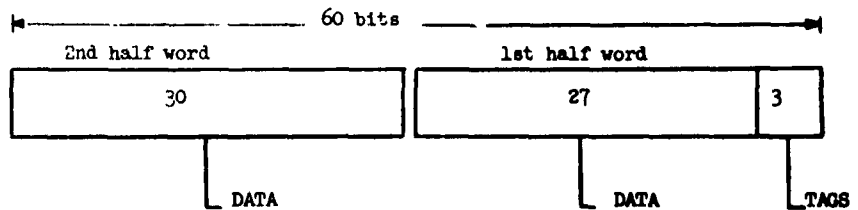

\*Mask bit = 1 means disregard in search.

Transfer Address Response Word Format

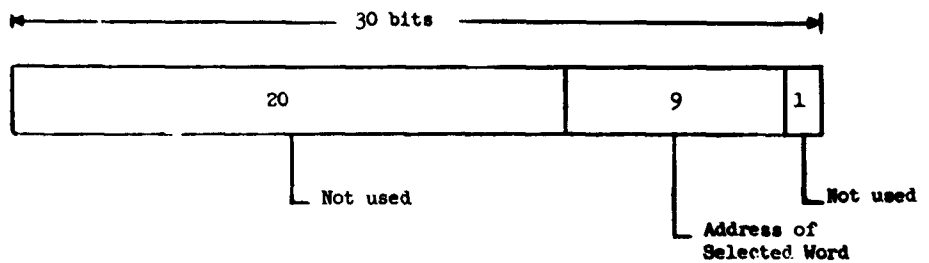

With suitable mask interrogation techniques and between-limit mixed searches, recognition memory can offer unique storage and interrogation facilities to permit transmission to ground stations of only that data sought after. For example: determine locations where static or dynamic missile testing has been conducted, or determine electromagnetic or infrared radiators within geographical boundaries defined by longitudes and latitudes.

#### 4. SECURE COMMUNICATIONS

Recognition memories can find novel applications in secure communications. Between-limits mixed searches become particularly useful for such applications.

#### 5. TRANSLATION

A recognition memory can find ready applications in language and code translation systems: an associative organization for unilateral and content-addressable organization for bilateral translations.

#### 6. SPACEBORNE TELEMETRY (INCLUDING TRANSMISSION OF BIOMEDICAL DATA)

The transmission of significant information over a given channel becomes important in spaceborne applications because of bandwidth considerations. The jump commutator can be particularly useful here in permitting the transmission of significant data only after it has been examined by a memory system.

#### 7. REMOTE DATA LOGGING

A recognition memory or jump commutator, or both, can be integrated within a remote nuclear instrumentation system or other remote data logging systems to permit the transmission of significant data over a limited bandwidth channel to a central processing center.

#### 8. COMMUNICATIONS BUFFER

A recognition memory may find an application as a communications buffer placed between the computer and data modem.

## 9. BUBBLE CHAMBER APPLICATIONS

Recognition memories appear to offer unique advantages in correlating data obtained from bubble chambers.

### G. USER/COMPUTER COUPLING TECHNIQUES

The direct coupling between the user and the computer still remains the weakest link in a digital system. Of the several techniques developed to bridge the gap, the more prominent are allied to on-line digital systems similar to the Culler-Fried approach. This comprises:

- (a) An organization which uses as elements mathematical functions (e. g., the coordinates of 100 points), rather than individual numbers
- (b) Control and display features which make direction of the computer by the user and feedback of graphical information from the computer rapid and convenient
- (c) A technique of "console programming" which allows the user to compose subroutines by pushing buttons.

## SUPPLEMENT A

### S-1. STRETCH

Basic  $16 \times 10^3$  words of core storage; 64 bits/word; 1  $\mu$ sec access time; add 2 15-digit numbers in 1.5  $\mu$ sec

32 input or output channels;

Read  $62 \times 10^3$  characters/sec;

Performs multiple read-write-computer operations simultaneously; can interrupt an operation to handle a problem of higher priority; has a semi-independent controller that relieves the computer of input-output housekeeping; Up to 256 tape units can be used in a system; It has the ability to look a few steps ahead in a program helping to make optimum use of its fast internal speeds.

### S-2. LARC

Basic  $10^4$  words of core storage; 12 decimal digits/word;

2  $\mu$ sec access time;

Add time is 4  $\mu$ sec;

10 input or output channels;

Read  $133 \times 10^3$  alphanumeric or  $2 \times 10^5$  decimal characters per second. Input-output processor can handle up to 60 tape units in multiple READ/WRITE operations while the arithmetic and logical unit continues with computing operations;

Semi-independent processor can also handle simple data manipulations not requiring computation.

### S-3. MUSE (Manchester-Ferranti Atlas)

Memory is comprised of 4096 word sections (2- $\mu$ sec access time) with consecutive addresses in different sections; memory operations are capable of overlapping with one section accessible while another is cycling, thus effective access rate is in excess of 1 mc; average time to extract and execute a complete single address floating-point addition instruction is about 1.1  $\mu$ sec. (Actual time depends on the amount of possible overlap with adjacent operations); Summing a polynomial takes about 5 to 7  $\mu$ sec per term;

Fixed memory for constants is a woven-wire mesh in which ferrite slugs represent ones;

Fixed memory also contains routines for initiating and controlling external transfers, for monitoring programs, for routine engineering tests and to control time-sharing between programs.

S-4. MARK VI (by Electrotechnical Laboratory of Japan's Ministry of International Trade and Industry)

The computer uses a 3-phase, 3-mc clock;

Memory is 8192 words of core storage; 52 bits/word; access time 2  $\mu$ sec; Supplementary high-speed storage unit for scratchpad purposes is a 0.2- $\mu$ sec tunnel diode memory;

Add time 1/2  $\mu$ sec.

8 tape units can be accommodated.

S-5. ILLINOIS COMPUTER (jointly with AEC, ONR, and the University of Illinois)

Memory is 8192 words, 52 bits/word core storage; 2- $\mu$ sec cycle time;

Floating add time 1.5 to 2.5  $\mu$ sec;

Multiply time 5 to 7  $\mu$ sec;

A drum store of 65,536-word capacity will be accessible in 17 msec maximum and once accessed, with a word transfer rate of 7  $\mu$ sec/word;

A speed-independent control contains logical circuits that can react to an input change after an indefinitely long time without affecting the result. The control helps ensure correct operation even if signal-transmission time exceeds circuit operation time;

Arithmetic and memory operations are overlapped; a look ahead control reads operands and instructions into a fast-access transistor register scratchpad store in advance.

S-6. CDC 3600

Up to 262,144 words; 48 bit/word; 1.5- $\mu$ sec memory cycle time, 0.7- $\mu$ sec effective cycle time;

Up to 24 bidirectional data channels;

4  $\mu$ sec floating point add; 1 to 6  $\mu$ sec, floating point multiply; data transmission control performed by high speed register located in Communication Module - permitting I/O activity to proceed independent and asynchronous of main computer program;

various special high speed circuits operating at 4 nanoseconds per stage.

SUPPLEMENT B  
AEROSPACE COMPUTERS

Tunnel-diode nanosecond circuits have been developed and experimented with. Consideration has been given to the application of the ternary flip-flop to tertiary logic and the design of a high-speed storage and arithmetic unit. The objective is a 50-mc clock rate, with random access to the store, and additions, at the clock rate. This subsystem is intended to operate as part of a large-scale subminiaturized computer.

In order to achieve speeds of this order, circuit techniques employing tunnel diodes and recently developed high-speed transistors would be applied. The storage unit would consist of tunnel diodes which can be read nondestructively. In order to exploit the high circuit speed, several logical design techniques are under consideration. At 50 mc, and with subminiaturization, spatial delays can be kept negligible, at least within this subsystem. Therefore, the first prototype would probably utilize a synchronous clocking system. For larger systems or higher frequencies, storage times in transmission lines between circuits would be accounted for within the logical equations.

Gating will be restricted to two levels, AND-OR, and OR-AND, with an inverter allowed within certain configurations. The simplicity of some of the tunnel diode circuits will partially offset the resulting logical inefficiency.

A preliminary logical design of the arithmetic unit and its coupling to the storage unit has been performed. Three major logical design features contribute to the speed with which general purpose arithmetic operations can be done. First, a portion of the high-speed store is dedicated to operands currently being processed; this portion of the store can be regarded as a bank of registers which can be switched into the arithmetic logic to perform addition, subtraction, multiplication, division, and logical operations. The numbers within this section enter directly into the arithmetic or logical operation called for without first being put in place in a particular register. Once the operands have been transferred to this section, it takes just one clock time to access the operands, perform an operation such as addition or subtraction, and store the result.

The other two logical design features deal directly with the speeding up of addition and subtraction, with corresponding benefit to multiplication and division. First, on the assumption that carry-propagation times would not prevent additions in one clock time, it was appropriate to adopt a scheme of addition or subtraction which could always be performed in one clock time regardless of the signs of the operands. To enable this, negative numbers in the arithmetic section of the store are kept in complementary form, so that recomplementation after a "machine subtraction" is not necessary. In order to avoid precomplementation for subtraction, an adder-subtractor operates directly on the operands as they are presented to it from the store.

The remaining problem was that of reducing carry-propagation time to enable one-clock addition. Of the various schemes evaluated, the use of redundant code representation of operands to allow storage of carries and borrows appears to be the best compromise for general purpose arithmetic operations. In this scheme, the result of an addition or subtraction consists of partial sum digits, and associated stored digits which are either carries or borrows. Intermediate results are stored in the arithmetic registers in this redundant code. Carries are not propagated, so addition and subtraction may proceed at the same speed as other logical circuits; in other words, at the clock rate.

The carry storage, coupled with a right-shifting capability, applies directly to the mechanization of multiply. Multiplication can be speeded up further, if deemed necessary, in a number of ways, one of which is to process two or more bits of the multiplier simultaneously. Another is to jump shift over strings of zeros. The borrow storage is used for the successive subtractions during division.

For storage in the high-capacity portion of memory, numbers are restored to conventional code by a full addition which assimilates the stored carries or borrows. Such storage is achieved through a separate adder, and can usually be done simultaneously with the high-speed arithmetic processing with no loss in speed. The carry assimilation must also be done prior to logical operations which inspect particular bits, such as compare.

One other method for "carryless" arithmetic which was evaluated is of considerable interest. This is known as the "conditional sum adder." Here, addition is performed in a sequence of  $(n + 1)$  steps for a word of  $2^n$  bits. During the first step, a sum and a carry are generated for each stage on the assumption of no carry into that stage, and a second sum and carry on the assumption of a carry in. During the second step, similar conditional sums and carries are formed for pairs of stages by choosing one of the two previously-generated alternatives. This process continues until, during the last step, the final sum is chosen.

The "conditional sum adder" is fast for a sequence of sums to be generated, as it can be generating several sums simultaneously. It has some serious drawbacks, however. If an addition followed by a different operation is required, the sum will not be available for  $(n + 1)$  clock times. Furthermore, at each step in the sequence, storage is required in order to resynchronize the conditional sums and carries in preparation for the next level of logic. This amount of storage is several times that required for one operand. It is also inefficient to perform accumulations of columns of numbers, and the addition algorithm does not lend itself conveniently to the mechanization of multiplication or division.

An alternative logical organization for arithmetic processes, which approaches the achievement of high speed in a quite different way, has also been under study for some time. This organization will be referred to as Multiple-Operand Processing (MOP).

In the subsystem described earlier, considerable additional expense is incurred in order to reduce the effect of carry propagation time on speed. This is necessary even with the most efficient logical design, because the programming of the arithmetic processes was approached in the conventional way. That is, it was assumed that the basic arithmetic instruction is a two-operand, parallel addition, and that such instructions are executed one at a time. Under such ground rules, the speed of program execution is ultimately limited by the speed of a single parallel addition. As a parallel adder is relatively expensive, it is not normally feasible to perform more than one parallel addition at a time. Once the adders have been designed to operate at the maximum circuit speed,

without being slowed by carry propagation, we have reached an impasse to further increases in speed, except through very expensive duplication of adders.

MOP avoids this impasse by processing operands serially, and performing multiple arithmetic operations simultaneously. The simplest implementation of MOP would be the trivial case of an arithmetic unit which performs a serial addition of two operands. The corresponding rate of execution of add instructions is very slow, but the simplicity of a serial adder makes it feasible to perform the addition of many operands during the same word time, and so to regain the speed lost due to serialization. In other words, there is a parallelization of operations rather than of the bits of each operand. The above case of a multiple-operand addition is only one of a large family of possible instructions which a MOP configuration can execute. (Assume that "instruction" is defined as the set of operations executed in one word-time.)

A typical MOP subsystem would consist of a working store for operands, and an arithmetic unit. The arithmetic unit would have an arbitrary number of input channels on which it can accept operands serially from the store, and an arbitrary number of output channels for writing results serially into the store. A single instruction selects operand and result addresses, and specifies the combination of operations to be performed. An instruction may specify what happens during a single word-time, or during a sequence of word-times. In programming a sequence of instructions, it is not always necessary to replace the complete instruction, but only those portions which change.

The working store would consist of tunnel diode shift registers independently accessible. On the assumption of a 50-mc clock rate, as before, the bit rate would be 50 mc. Assuming a word length of 50 bits, the word time would be one microsecond. The amount of computation performed within this one microsecond is limited only by the number of arithmetic channels we are willing to build into the hardware.

Add, subtract, compare, and similar operations which inspect the bits of operands sequentially can be executed in one word time. Others,

such as multiply and divide, require two word-times to generate double-length results. For example, a serial-serial multiplication requires two full-word registers and two word-times for execution.

Within one instruction, several operands (up to a maximum of the number of input channels) may enter into the same arithmetic operation, such as the totalling of a column of numbers. Alternatively, several independent operations may be performed, and the intermediate results combined in further operations during the same instruction. Additions can be conjuncted with multiplications during the second word-time of the multiplication, for single precision results. Thus long strings of sums of products, such as occur in vector operations or in matrix multiplication, can be executed simultaneously within 2 word-times, or 2  $\mu$ sec.

Assuming a 50-bit word, it might at first appear that 50 arithmetic channels would be necessary in order to match the speed of a conventional parallel machine. It can be shown that this is not true by a large factor. In fact, it is estimated that a MOP unit with anywhere from 8 to 24 channels will be comparable in speed, depending on the nature of the program. A number of factors contribute to this gain in arithmetic efficiency, but the significant effect of most of them can be summarized as follows: the simultaneous processing of several operands allows a relatively high number of operations per operand to be performed for each access to that operand. In a conventional machine it is typical to perform one operation (such as an add) for an access to one or two operands. In a MOP unit, it would be common to perform two or more operations for an access to one operand. As an example of an operation at which MOP would excel for these reasons, consider a search through 16 words against any one of 8 criteria. A 24-channel MOP unit would make the search with one instruction, in one word-time, or one microsecond. A conventional machine would have to perform a sequence of 128 comparisons interspersed with test instructions.

In summary, MOP holds the potential for the following advantages over a conventionally-programmed arithmetic unit.

(1) Data can be processed without delays due to carry propagation, and without additional expense to avoid it.

(2) Simultaneous processing of operands leads to increased arithmetic and logical efficiency.

(3) MOP provides a limitless range of processing speeds. Speed and versatility can be increased in small or large increments by modular addition of "logical operators" such as adders.

(4) The construction of a MOP unit benefits from a modularity which breaks along arithmetic channel lines. The logical structure is open-ended; the initial structure does not in any way limit the choices of further additions. The arithmetic capability is not determined by word length or word structure. Only those capabilities required for the problem to be solved need to be included in the unit.

(5) The instruction language has a closer resemblance to the problem, which does not need to be broken so finely into a sequence of elementary steps. An instruction might be expressed as a formula to be evaluated, or a function such as "search n words."

(6) As one, or a few arithmetic channels can operate independently from others, several programs can be run truly simultaneously without interference. In other words, a MOP unit can be regarded as one processing unit or several.

#### SUMMARY

The logic elements described in this Supplement, together with the fast memory discussed in Section B, suggest the feasibility of constructing an experimental airborne or spaceborne miniature digital computer.

TRW has considered logical circuits employing tunnel diodes and nanosecond switching for application to the design of very high-speed computers (see Table S-I.).

A preliminary design study of a large-scale, microminiaturized, spaceborne computer based on tunnel diode and transistor circuits has been considered. It has been contemplated that such a computer should employ a 20-mc clock, 0.1-microsecond add time, and 1.0-microsecond multiply time.

In such a computer, arithmetic operations exploit the potential high-speed of tunnel diodes. Operands and results being used currently are to be held in a working store consisting of tunnel diodes. This store can be written in, or read out nondestructively, at 20 mc. The numbers held in the store are to enter directly into arithmetic operations such as addition without being first transferred into a separate register. An adder-subtractor takes one clock-time (50 nsec) to inspect operand signs and enter the sum or difference into an accumulator. Recomplementations (if necessary) and storage would occur during a second clock time, for a total add time of 0.1 microsecond. Carry propagation time through 48 bits is kept below 50 nsec with carry bypass circuits which limit the longest carry path to about 12 stages.

The design of a still faster storage and arithmetic unit employing tunnel diodes is also being studied. Contemplations are for such a unit to operate at a clock rate of 50 mc, and employ "carryless" or "modular" arithmetic. For this scheme, numbers are to be stored in two's complement form in a redundant code which allows for storage of carries or borrows resulting from addition or subtraction. Add time is to be one clock time, or 20 nsec.

Five types of airborne or spaceborne computers that have been considered are described in Tables S-I through S-V.

## PROPOSED SPACEBORNE LARGE-SCALE COMPUTERS

Table S-I

<b>Type:</b>	Spaceborne or airborne. Large-scale, general purpose. (for digital computation, processing, and control) Ultra-high speed and quick real-time response. Binary, parallel, fractional, floating point. Powerful automatic indexing. Multi-programming features. Flexible, generalized instruction set. Word length: 48 bits. Weight: 300 lb.(with 32,768 word memory) Volume: 5 cu ft
<b>High-Speed Store:</b>	Type: tunnel diodes, random access. Capacity: 256 words. Read or write speed: 20 megacycles.
<b>Memory:</b>	Type: core, random access, coincident current. Capacity: unlimited, in increments of 4096 words. (blocks of 32,768 words directly addressable) One read-write channel per bank of 4096 words. Read-write cycle per bank: 2 microseconds. Multiple, asynchronous access.
<b>Speed:</b>	Clock rate: 20 mc. Add: 0.1 $\mu$ sec. Multiply: 1.0 $\mu$ sec. Divide: 1.5 $\mu$ sec. Square root: 1.5 $\mu$ sec.
<b>I/O:</b>	Wide variety of external devices. Monitoring and control of many external functions. Max. transfer rate: 1,000,000 words per second, per channel. Up to 4 channels: 64 devices per channel. Tunnel diode exchange.
<b>Components:</b>	Cores, tunnel diodes, transistors (germanium).
<b>Status:</b>	Preliminary design.

Table S-II

**Type:** Spaceborne or airborne.  
Large-scale, ultra high speed.

**Features:** Binary, parallel  
48 bit words  
Fixed or Floating point.  
Automatic indexing and multi-programming features.  
Flexible, generalized instruction set.  
Interrupt features for fast real time response.

**Memory:** Core Memory, 2  $\mu$ sec Read Write cycle.  
Expandable in groups of 4096 up to 128k words.  
High speed tunnel diode associative memory.  
Read or Write at 20 mc.  
Initial size 256 expandable to 1024.  
High speed store used as a "virtual" memory to provide  
fast access to repeatedly used words.

**Speed:** Clock rate 20 mc.  
Add 0.1  $\mu$ sec.  
Mult. 1.0  $\mu$ sec.

**I/O:** Wide variety of I/O devices.  
Up to 4 channels, many devices per channel, transfer  
rates up to 1 mc.  
Polymorphic capability.

Table S-III

<b>Type:</b>	Spaceborne or airborne. Large scale, high speed.
<b>Features:</b>	Binary, fractional, parallel 48 bit words. Sophisticated arithmetic unit. Flexible fixed point instruction set. Interrupt features.
<b>Memory:</b>	Magnetic core memory. Read-Write cycle, 2 $\mu$ sec. Expandable in groups of 4096 up to 32,768 words. High speed tunnel diode memory for scratch pad. Read or Write at 20 mc. Initial size 256, expandable to 4096 words.
<b>Speed:</b>	Clock rate 20 mc. Add 0.1 $\mu$ sec. Mult. 1.0 $\mu$ sec.
<b>I/O:</b>	Two channels with two devices per channel. Rates up to 1 mc.

Table S-IV

**Type:** Spaceborne or airborne.  
Small scale, stored logic.

**Features:** Binary, fractional, parallel.  
24 bit word, adaptable to multiple precision.  
Capable of executing wide variety of instruction sets by appropriate programming, including those of machines I and II.  
Flexible interrupt features.

**Memory:** Magnetic core memory.  
Read-Write cycle, 2  $\mu$ sec  
Expandable in groups of 4096 up to 32,768 words.  
High speed tunnel diode memory for scratch pad.  
Read or Write at 20 mc.  
Initial size 256, expandable to 4096 words.

**Speed:** Clock rate 20 mc.  
Add 0.1  $\mu$ sec.  
Mult. 1.4  $\mu$ sec (24 bit words).

**I/O:** Two channels, expandable as needed.  
Transfer rates up to 1 mc.

Table S-V

**Type:** Spaceborne or airborne.  
Small scale, very high speed.

**Features:** Binary, fractional, parallel.  
24 bit word, easily adaptable to double precision.  
Efficient, easy-to-use instruction set.

**Memory:** High speed tunnel diode storage.  
Read or write speed 20 mc.  
Initial size 256 words, expendable to 4096.

**Speed:** Clock rate 20 mc.  
Add 0.1  $\mu$ sec.  
Mult. 1.4  $\mu$ sec.

**I/O:** Two channels.  
Transfer rates up to 1 mc.

## BIBLIOGRAPHY

1. A. Corneretlo, "Three-K Bit Associative Memory Works at Room Temperature," Electronic Design, 5 July 1962.
2. P. M. Davies, "A Superconductive Associative Memory," Proc. AFIPS, SJCC, May 1962, pp. 79-81.
3. P. M. Davies, "The Associative Computer," Workshop on Ultra Fast Computers, Lake Arrowhead, California, 1962.
4. A. D. Falkoff, "Algorithms for Parallel-Search Memories," Journal of the ACM, October 1962.
5. R. Fuller, "Content-Addressable Memory Techniques," Workshop on Ultrafast Computers, Lake Arrowhead, California, 1962.
6. J. Goldberg and M. W. Green, "Large Files for Information Retrieval Based on Simultaneous Interrogation of All Items for Computing Systems," to be published by ONR.
7. L. C. Hobbs, "Review and Survey of Mass Memories," FJCC, November 1963.
8. E. C. Joseph and A. Kaplan, "Target Track Correlation with a Search Memory," 6th National MIL-E-CON, June 1962.
9. J. R. Kiseda, H. E. Petersen, W. C. Seelbach and M. Teig, "A Magnetic Associative Memory," IBM J. Res. and Dev., April 1961, pp. 106-121.
10. M. H. Lewis, "Retrieval of Ordered Lists from a Content-Addressed Memory," RCA Review, June 1962.
11. W. L. McDermid and H. E. Petersen, "A Magnetic Associative Memory System" IBM J. Res. and Dev., pp. 59-62.
12. R. C. Minnick, "Magnetic Comparators and Code Converters," Presented at Symposium on the Application of Switching Theory in Space Technology, Sunnyvale, California, February 1962.
13. V. L. Newhouse and R. E. Fruin, "A Cryogenic Data Addressed Memory," General Electric Res. Lab., Schenectady, New York, Report No. 62-RL-2985E, April 1962; also Electronics, 4 May 1962, pp. 31-36.
14. N. S. Prywes and H. G. Gray, Jr., "Multilist Organized Associative Memory," Moore School of Elec. Eng., Univ. of Pa., Philadelphia, January 1962.
15. R. F. Rosin, "An Organization of an Associative Cryogenic Computer," Proc. AFIPS, SJCC, May 1962, pp. 203-212.

16. R. R. Seeber, Jr., "Associative Self-Sorting Memory," Proc. EJCC, December 1960, pp. 179-188.
17. R. R. Seeber and A. B. Lindquist, "Associative Memory with Ordered Retrieval," IBM J. Res. and Dev., January 1962.
18. A. E. Slade and H. O. McMahon, "A Cryotron Catalog Memory System," Proc. EJCC, December 1956, pp. 115-120.
19. A. E. Slade and C. R. Smallman, "Thin-Film Cryotron Catalog Memory," Solid State Electronics, September 1960, pp. 357-362.
20. "True Content-Addressable Memory," Technical Note 423-1, Ramo Wooldridge Laboratories, Canoga Park, California, April 1962.
21. U. S. Patent No. 3031650, A Memory Array Searching System.

## Appendix XXVII. EXECUTIVE CONTROL PROGRAM FOR INSTRUMENTATION STATIONS

### A. INTRODUCTION

During the 1965 to 1970 time period, instrumentation stations will be faced with the need for handling multiple missions. Future station equipment must be capable of rapid reaction to new requirements and adaptation to a constantly changing set of conditions. Associated with any specific mission, a set of special-purpose computer programs can be written to perform each of the data processing functions which may be required. These programs transform and interpolate acquisition coordinates, reduce telemetry data, update orbital parameters, operate displays, verify data, etc. It is not the purpose of this appendix to consider such routines: the analytical techniques are varied and are constantly being improved and modified. The purpose here is to investigate the manner in which any arbitrary collection of such routines can be efficiently intermixed to provide effective processing for simultaneous missions. The approach used is to break the processing requirements for each mission into a set of standardized subroutines. The exact internal nature of each subroutine is not important, only the manner in which the routine is used. For example, in normal scientific data processing, a subroutine for computing the sine of  $x$  may be available. The programmer, following a specific set of rules, may present a value of  $x$  to this subroutine and receive back the value of  $\sin x$ . Later changes in the  $\sin x$  subroutine can be made without affecting any of the programs already written which require a  $\sin x$  computation, provided certain simple rules are followed. The programmer using the  $\sin x$  subroutine does not care whether it uses a series evaluation, a Hastings approximation, or some other algorithm (assuming each gives suitable accuracy for his application). Likewise, the developer of the  $\sin x$  subroutine is not concerned, in general, with the ultimate application of the routine. In the following sections, the philosophy of a control program/subroutine technique will be developed for a generalized instrumentation station and the implementation investigated.

## B. BASIC ELEMENTS

The technique to be described is not simple. The interaction of the elements requires an understanding of all of the elements, and yet the description of each separate element is difficult to follow until all elements have been described. Each basic element will be briefly described, followed by a brief summary of the overall control program; then the important elements will be described in greater detail.

### 1. TRAPS

All input/output devices may interrupt the computer at any time by entering a trap mode. Each trap will call up a specific routine called a "trap processor."

Trapping will usually be associated with a data transfer; hence, a block of buffers, known as "trap buffers," will exist as an interface between the data processor and the outside world. Trapping may also signal a special condition such as parity error, power failure, time interval, register overflow, etc.

A trap is actually a "priority interrupt," although to avoid confusion with the later use of the word "priority," only the word "trap" or "trap interrupt" will be used. The priority associated with a trap is merely a hardware convenience related to the permissible delay an input/output device can endure before acknowledgement of a trap interrupt. Each trap is always permitted to interrupt the processor within some very short maximum interval of time so that a trap may be delayed but never ignored. Thus all devices which are capable of trapping have essentially an equal priority.

### 2. TRAP PROCESSORS

Whenever a trap takes place, a chain of operations is initiated:

- 1) Trapping is disabled; i. e., no further trap interrupts are permitted to take place.
- 2) The interrupted routine, if an ordinary processor, is preserved. Thus, the

- contents of the arithmetic registers and the next instruction address are stored.
- 3) The trap signal from the device which initiated the trap is turned off.
  - 4) A routine associated with the trap, called the "trap processor," is entered and the programmed sequence of operations performed.
  - 5) The trap mode is enabled. If another trap has taken place while the above steps are followed, then Steps 1, 3, 4, and 5 are repeated.
  - 6) If two or more traps are waiting, then Step 1 will be performed and Steps 3 and 4 for each of the traps (according to trap priority) before the trap mode is again enabled.
  - 7) If no additional traps are waiting, then control is transferred to the "priority table search" routine.

Trap processors will, in general, perform two operations: they will flag one or more items in the priority table with "Request" bits and "Suppress" bits; and they will usually initiate a transfer of data. Since the computer used must have the capability for simultaneous data transfers while computing, computation will not be delayed while the transfer is taking place. Frequently, the completion of the transfer will initiate a trap to signal the computer. Trap processors must have two important properties; they must be performed in a minimum of time; and they must be written completely independent of any mission. The maximum time a trap processor can take is a function of the frequency of trap interrupt loading, probable time between traps, and permissible trap acknowledgment delays. The two design factors affecting this will be computer speed and buffer storage size. These processors are "hardware," rather than "mission," oriented.

### 3. PRIORITY TABLE

The priority table is an ordered listing of the classes of processes which might be required for any mission. Each entry in the table refers to a specific, nonmission-oriented "ordinary processor" which in turn refers to a constantly varying set of mission-oriented subroutines.

While the position of the processor in the priority table implies a fixed order of priority, it is actually possible for lower priority operations to be performed before a higher priority operation. This is accomplished by the presence of flag bits associated with each entry in the table. A request bit is set whenever a processor is desired. Another bit indicates whether a processor has been interrupted. An additional set of bits is reserved as suppress bits. When a processor is suppressed, it is usually to permit some other processor to have a higher priority. The second processor will then remove the suppress bit from the first processor. Suppose that processor A is to be suppressed until both B and C have been performed. This would be accomplished by placing two suppress bits in A: one which can only be removed by B, and another which can only be removed by C. This is the reason for multiple-suppress bits. Requests and suppressions can be set by ordinary processors, as well as trap processors. Whenever a routine is suppressed, then at the same time the routine or routines which will directly (or indirectly) release the suppressed routine must always be requested.

### 4. ORDINARY PROCESSORS

As mentioned in the previous section, the priority table refers to a list of ordinary processors. A trap processor will not only request an ordinary processor, but will, in general, make an entry into a queue table associated with that processor. After inspection of the entry in the table, the ordinary processor will be able to determine which subroutine processor to use.

An example of an ordinary processor may clarify its use. One item in the priority table would be "compute and transfer acquisition data."

This would include not only acquisition for tracking but receipt of telemetry as well. The trap processor would indicate which antenna needs pointing information and would indicate the mission. The ordinary processor would contain a set of subroutines for all currently active missions. It might have to perform different transformations and interpolations for each mission and, in addition, might make special calibration adjustments for each antenna. When the new coordinates are determined, the address of the coordinates, together with the identification of the device which needs them, is placed in the queue table for a particular processor and that processor requested.\* The processor requested is "transfer information from computer to external source;" then that ordinary processor, of course, will move the data to the proper output buffer and will initiate the transfer.

One comment with regard to priority table flag bits should be made. The processor selected will always be the highest item in the table which is not suppressed, and which possesses a request bit and/or an interrupt bit. If the interrupt bit is on when a processor is entered, then it will always start at the point at which it was interrupted. If the interrupt bit is not on, it will immediately be turned on before processing begins. If there is only one item in the queue table, then the request bit will be turned off. When processing is complete, the interrupt bit is turned off. Whenever a processor is completed, a priority table search will be initiated:

Whenever an ordinary processor is placing suppress flags in the priority table, trapping will be disabled long enough to permit the placing of the proper request flags.

## 5. QUEUE TABLES

Associated with each ordinary processor will usually be one or more queue tables. One table will provide a listing of the location and identification of available mission subroutines. Another table will indicate the location and identification of data to be processed by the ordinary processor.

---

\* Phased arrays, if used, would be handled in a different manner.

Trap processors may also have queue tables. For example, the time trap would refer to an action time table to determine the time of next trap and to determine specific actions to be taken.

## 6. MISSION SUBROUTINES

The significance of mission subroutines is probably obvious from the previous comments. These routines are called into the computer by the GRCC or MCC via an IFCS,\* and identified with particular missions and equipment. While there are no restrictions placed upon the nature of possible subroutines, it is obvious that their complexity can place severe requirements upon local computers.

One additional concept should be noted. Each mission has a priority number. Whenever an ordinary processor is called up, the mission subroutines will be performed according to mission priority. If there are multiple entries in the queue table, the oldest request for the highest priority mission will always be honored first. Of course, if there is only one mission being processed, mission priority presents no problem; however, many missions have multiple, asynchronous telemetry links and the load upon the computer for these single missions is equivalent to multiple missions. Thus, processing a PCM link, a PAM link, and continuous analog data from one mission is equivalent to processing one link from each of three simultaneous missions. Different mission priorities could be applied to each link to insure, for example, that PCM data will always be transmitted in real time while any delay will affect only PAM (or continuous analog data).

## C. GENERAL SYSTEMS DESCRIPTION

Combining these elements, a system can be organized which can best be described as an information store-and-forward program with some intermediate processing. All inputs are stored. If the loading is light, all data is processed and forwarded in real time. When the system is overloaded, then communication lines and data processing equipment will be utilized to their optimum capacity. Some data, of

---

\* Global Range Control Center (GRCC); Mission Control Center (MCC); Information Flow Control Station (IFCS).

necessity, must be delayed. Data will be delayed according to priority of mission and priority of data within the mission. The data from each mission is always divided into three classes: Class A which is desired in real time, Class B which may be delayed, and Class C which should be preserved for future reference but not transmitted. Class A will be processed and transmitted according to mission priority for all missions before any Class B is transmitted. The quantity of Class A data will determine the speed requirements for the processor, while the Class B will influence the amount of storage needed.

#### D. PRIORITY TABLE

Table I presents a tentative listing of ordinary processors. Certain notations will facilitate discussions.

$P_i$  will denote the  $i$ th ordinary processor in the priority table. Thus  $P_2$  is "transmit command to spacecraft."

Table I. Priority Table

1.	Inspect special instructions
2.	Transmit command to spacecraft
3.	Transfer information from external source to computer
4.	Transfer information from computer to external source
5.	Compute and transfer acquisition data
6.	Extract, identify, and store telemetry data
7.	Process Class A data, identify, and store
8.	Process Class B data, identify, and store
9.	Perform requested station checkout routine
10.	Perform short computer check
11.	
through	Perform special routine
14.	
15.	Perform general diagnostic routine.

$P_i R$  means that the  $i$ th ordinary processor has been requested;  $P_i I$ , the  $i$ th ordinary processor, has been interrupted;  $P_i S_{j,k}$ , the  $i$ th ordinary processor, has been suppressed, and the suppress flags can be removed only by  $P_j$  and  $P_k$ .

Additional combinations of the above symbols can be made. Thus,  $P_8IRS_{10}$  means that ordinary processor  $P_8$  was interrupted, has been requested (indicating that one or more items have been added to the queue table), but will not be performed until after the completion of  $P_{10}$ .  $Q_i$  represents the queue table associated with  $P_i$ .

A set of symbols is also required for traps and trap processors. Since trap processors usually request ordinary processors, it would be useful if the traps could be associated with the corresponding ordinary processor subscripts. Thus,  $T_i$  is the  $i$ th trap and  $TP_i$  is the trap processor associated with  $T_i$ . If  $i$  is less than or equal to 15, then  $TP_i$  always sets  $P_iR$ , i. e., requests  $P_i$ . Since there may be several devices that can trap, which call up the same trap processor and request the same ordinary processor, this would be denoted by  $T_{i,j}$ . For example, suppose there are three output communication lines from the station. Whenever the transmission of a given block of data over a particular line has been completed, a trap would be initiated so that another block could be transmitted. Hence,  $T_{4,2}$  is a trap indicating that transmission has been completed over line 2 and  $TP_4$  will set  $P_4R$  so that an inspection of  $Q_4$  will determine whether a new block of data is available for line 2.

## E. PROGRAM DETAILS

### 1. TRAP $T_{1,j}$ (SPECIAL INSTRUCTIONS)

Trap  $T_{1,j}$  is associated with the  $j$ th incoming communication line. This is ground-to-ground communications and means that instructions or data will be sent from GRCC or MCC.  $TP_{1,j}$  will set  $P_1R$  and will indicate in the  $Q_1$  table that buffer "j" contains incoming information.

Returning to the priority table search,  $P_1R$  will transfer to processor  $P_1$ .  $P_1$  will inspect the first few characters stored in the "j" buffer. A coded message will indicate the proper action. The following is a possible but not probable code. In actual practice, a more efficient code would be selected. This code, however, illustrates the principle and facilitates discussion.

- 1) M = Message will follow. Use code list below  
N = No message will follow  
Use remainder of code group for address  
of instructions  
S = symbolic, A = actual
- 2) Connect line to following device  
T - Teletypewriter  
P - Paper tape punch  
M - Magnetic tape unit  
C - Card punch  
L - Line printer  
D - Display device buffer  
H - High speed computer memory
- 3) Indicate choice of multiple devices of classes listed in 2.  
If only one, then indicate 1. For "H," high speed  
computer memory, the initial address must be  
indicated
- 4) Should receipt of message be verified and acknowledged?  
N = No  
Y = Yes
- 5) Method of verification  
0 = Operator acknowledgement that message  
received and understood  
1 = Compute and compare check sum  
2 = Verify hamming code  
3 = Transmit complete message back to sender  
4 = Acknowledge end of transmission, etc.
- 6) Should message be identified and location  
remembered?  
Y = Yes  
N = No

- 7) Associate message with the following identification code number xxxx. This code, for different types of messages, will be further subdivided to provide specific information. For example, number of words in message, priority, mission, symbolic name, etc.

The following are examples of coded instructions:

MTIYON - Message will be typed out on teletypewriter No. 1. Operator acknowledgement of message receipt is requested. The computer need not remember that such a message has been received.

MM5Y1Y12345 - Message to be stored on magnetic tape unit No. 5. Message should be verified by computing check sum and acknowledged. Identify message as number 12345 and remember storage location.

NA3781 - No additional message will be sent; take next instructions from actual core location 3781.

Note that by this hypothesized set of coded instructions, the GRCC, IFCS, or MCC can maintain complete control of the IS (instrumentation station).

When a message is being received, the actual transfer of the message will take place in parallel with computation. Another trap is needed to indicate the end of the message. The end of message trap could be handled in a variety of ways: a signal over a separate line, a special code, a special multiplexed frequency, at the end of a pre-determined word count, etc. In practice, one or more of these techniques could be used. One other method would be to generate a trap whenever transmission stops. Thus,  $T_{1,j}$  could signal that transmission was stopped on line "j." Such a trap would disconnect those connections made by  $T_{1,j}$  and reinstate trapping of future  $T_{1,j}$  signals. It would also provide a means of testing for and recognizing line failures or interruptions, especially if verification of message had been requested. Via these coded messages, instructions will be given to local operators, programs transmitted and stored on magnetic tape, routines transferred from tape to computer memory, special checks of computer and station equipment conducted, simulation exercises run, spacecraft commands generated, previous Class C data recovered for analysis, etc. Note that if the special instructions are of low priority,

they can be transmitted as an ordinary processor and placed in positions 11 through 14 in the priority table. If the incoming line is of relatively slow speed, the message may be entered into the computer, under computer control, one computer word at time. This is the situation which will probably exist for most stations.

## 2. TRAP $T_{16}$ (TIME TRAP)

At certain time intervals, a time trap will occur. The associated trap processor will refer to a stored time table and will initiate the proper request for ordinary processors in the priority table. Because of the constantly varying frequency for time indications, it appears useful to use special hardware for this purpose. Thus, the trap processor, after each trap, would set in a buffer the next interrupt time. When that time is reached, then trapping will occur.

The stored time table  $Q_{16}$  would have the proper action stored by each time. Thus  $P_2R$  might be set to initiate transmission of spacecraft commands,  $P_3R$  to call for the specific transfer of the program of a future mission from tape,  $P_5R$  to present acquisition information to antenna,  $P_9R$  or  $P_{10}R$  to initiate computer or station checkout, etc. Action times will be placed in  $Q_{16}$  by ordinary processors and by special instructions from GRCC, MCC, LRCC,\* or IFCS.

## 3. ORDINARY PROCESSOR $P_2$ (SPACECRAFT COMMANDS)

Spacecraft commands would be transmitted from the MCC and the storage location of the command, together with an indication of equipment to be used and time of transmission placed in  $Q_2$ . Several sets of such commands might be stored for future transmission. Customarily, at least two sets would be used: the basic commands, and an "execute" command to be sent only after verification of the first set. If the command is for immediate transmission, then a time code of 0000 would be entered and  $P_1$  would set  $P_2R$ . If the commands were not for immediate transmission, then the time with identification would be entered into  $Q_{16}$ . The execute command would always have a nonexistent time code. When the first set of commands has been received and verified by  $P_6$ ,

---

\* Local Range Control Center

then  $P_2R$  would be set and the execute time code changed to 0000. If the commands are not verified, a copy of the commands as received back would be transmitted to the appropriate MCC (via  $P_4$ ) and would be retransmitted to the spacecraft. This retransmission would continue until verification is received or until stopped by the MCC via  $P_1$ .  $P_2$  would flag  $P_6$  to check for retransmitted commands and would indicate the storage location of the commands transmitted.

#### 4. ORDINARY PROCESSOR $P_3$ (LOCAL DATA TRANSFERS TO COMPUTER)

Processor  $P_3$  is charged with the responsibility of keeping track of memory storage blocks and the location and identification of all routines available at the station. The queue table  $Q_3$  will store the following information for routines or data which should be transferred to the computer as soon as possible or at some time in the future:

The time of transfer (0000 indicates immediate transfer)

Identification number for routine

External storage location, for example, magnetic tape reel number, punched card tray number, etc.

Input device identification

Method of verification of transfer

Memory storage required

Indication that transfer is in process

Indication that verification is complete

Which ordinary processors should be notified when routine or data transfer is complete.

Another part of  $Q_3$  would keep track of which local data transfer input devices are available for transfer (that is, turned on and loaded), which are actually in use, and which have been requested. When a specific tape reel is needed on a certain tape unit, a prestored request at the proper time would be indicated to the local operator by  $P_4$ . Whenever a transfer has been completed, the input device will generate a  $T_{3,j}$  trap which will set  $P_3R$ . This will permit start of verification and relocation,

if needed, and notify  $Q_3$  that the device is no longer in use. Since the transfer is made in parallel with computation, lower priority routines may be followed while the transfer is taking place. Two problems do exist: the amount of computing time required for verification of transfer; and the possible requirement for relocating a subroutine in the memory. With the proper type of computer, the relocating could be handled by index registers, indirect addressing, or relative addressing; however, verification might require appreciable computation. One simple approach would be to establish another ordinary processor, say  $P_{11}$ , to perform these functions without interfering with necessary real time operations. For purposes of this appendix, we assume that verification and relocation require a negligible amount of time and hence will be performed by  $P_3$ .

#### 5. ORDINARY PROCESSOR $P_4$ (DATA TRANSFERS FROM COMPUTER)

Before discussing  $P_4$ , it would be well to summarize all possible input/output devices associated with this system and their relationship to the ordinary processors. Table II provides such a summary. A number of arbitrary decisions have been made; however, this is not important provided the ordinary processors are defined with these decisions in mind. While  $P_3$  accepts inputs from only four classes of devices,  $P_4$  will output to 11 classes and will perform functions ranging from antenna pointing and switching of local equipment to the transmission of processed data.  $P_1$  provides for the immediate display of information to local station personnel while  $P_4$  permits delaying this information if desired. Data is stored in  $Q_4$  from many other processors. A different portion of  $Q_4$  will be used for each possible output device and, when  $Q_4$  is searched, it will be searched according to the following priority:

Antenna acquisition information

Data for transmission to MCC

Local malfunction alarms

Magnetic tape storage

Other output devices.

Each of these portions of the queue table should be considered separately.

Table II. Input/Output Devices and Their Relationship  
to Ordinary Processors

<u>Input/Output Device</u>	<u>Ordinary Processors</u>								
	<u>P<sub>1</sub></u>	<u>P<sub>2</sub></u>	<u>P<sub>3</sub></u>	<u>P<sub>4</sub></u>	<u>P<sub>5</sub></u>	<u>P<sub>6</sub></u>	<u>P<sub>7</sub></u>	<u>P<sub>8</sub></u>	<u>P<sub>9</sub></u>
Communication Lines	I			O					
Telemetry Receivers						I			
Spacecraft Command Transmitters		O							
Antenna Pointing				O					
Antenna Lock-on					I				
Antenna Position					I				
Magnetic Tape Units	O		I	O		O			
Auxiliary Memory	O		I	O					
Computer Memory	O	I	O	I	O	O	I/O	I/O	I
Paper Tape Punch	O			O					
IBM Card Punch	O			O					
Paper Tape Reader			I						
IBM Card Reader			I						
Teletypewriter	O			O					I/O
Line Printer	O			O					O
Signal Lights	O			O					O
Displays	O			O					O
Operator Console									I
Equipment Switching and Control				O					O
Equipment Checkout									I

I = Input from Device; O = Output to Device

a. Q<sub>4. a</sub> Antenna Acquisition

As will be discussed later in greater detail, P<sub>5</sub> computes and stores in Q<sub>4. a</sub> the acquisition information. Provided lock-on has not been achieved, P<sub>5</sub> will store in Q<sub>4. a</sub> the following information:

Time data is required  
Coordinates in proper format  
Output buffer address  
Mission identification  
Lock-on status

When P<sub>4</sub>R is set by the time trap and the time corresponds to a time in the table, then the coordinates will be transferred to the proper output buffer and the entry removed from the table. If only one entry remains for that mission, then P<sub>5</sub>R will be set. If P<sub>4</sub>R was set by other than a time trap, then Q<sub>4. a</sub> will be skipped. The action taken when lock-on is achieved is discussed in Section E. 6.

b. Q<sub>4. b</sub> MCC Data Transmission

Data for transmission to the MCC can be placed in Q<sub>4. b</sub> from many sources. The major sources would be P<sub>7</sub> and P<sub>8</sub> and P<sub>5</sub> when lock-on has occurred. The Q<sub>4. b</sub> table would contain:

Data class (A or B)  
Priority number  
Time of data  
Address of data (beginning and end)  
MCC destination  
Type of processing (raw data, processed, position, etc.)  
Transmission line (or lines) to be used  
Other identification codes.

Every time a new entry is placed in Q<sub>4. b</sub>, P<sub>4</sub>R is set. Data is extracted and transmitted according to the following priority for each available transmission line:

Data class

Mission priority

Oldest data.

The  $Q_{4, b}$  table assumes multiple communication links from the station to various MCC's with only certain lines available for certain missions. The search would be made on only the lines not then in use. If all lines are busy, then  $P_4R$  and  $P_4I$  will be turned off and search returned to the priority table. Note, while items do remain in the queue table, they cannot be processed; hence  $P_4R$  is not left on. However, as soon as any communication line output is completed, a trap  $T_{4, j}'$  will immediately reset  $P_4R$ . If there are no additional outputs available for that line, then  $P_4R$  (and  $P_4I$ ) will again be turned off. As will be noted,  $P_4$  is attempting to keep the output communication lines fully loaded. If the computer cannot process data fast enough to keep up with the communication capability, then raw data will be taken from  $Q_7$  or  $Q_8$  and transmitted to the nearest IFCS where overload processing will take place. In any event, Class A data will always be transmitted before any Class B data and all of the highest priority Class A data will be sent before any lower priority Class A data.

c.  $Q_{4, c}$  Local Malfunction Alarms

A variety of special traps can indicate various malfunctions such as loss of power on a particular unit, parity error, broken tape, voltage overload, incorrect tape loaded, etc. While in many cases the trap processor may directly turn on signal lights, sound buzzers, etc., special stored instructions can be displayed or printed out indicating to the operator corrective action or presenting quantitative details about the malfunction. In particular, entries will be placed in  $Q_{4, c}$  by  $P_9$  and  $P_{10}$ .

d.  $Q_{4, d}$  Magnetic Tape Storage

Entries into  $Q_{4, d}$  will indicate blocks of computer data to be stored on magnetic tape. This would include the identification of the data, the tape unit, and the beginning and end of block.

e. Q<sub>4. e</sub> Other Output Devices

Output to all other devices at the station would be controlled by entries in Q<sub>4. e</sub>.

6. ORDINARY PROCESSOR P<sub>5</sub> (ACQUISITION DATA)

Some time prior to the first pass (weeks or even months) the program for processing acquisition data is transmitted and stored on magnetic tape (P<sub>1</sub>). This routine will take data transmitted from the IFCS\* and perform the required coordinate transformation and interpolation for antenna pointing. The routine is identified by a code number and also by reel number. The routine (under control of IFCS would be called into memory, verified by check sums, hamming codes, etc., and would be further checked out by simulation runs (P<sub>3</sub> and P<sub>5</sub>). After verification the local operator would be instructed to store reel for future use.

Several hours before the scheduled pass the operator would be instructed to place reel on a specific tape unit (P<sub>1</sub>). At the same time, the IFCS would enter a number of items into the computer time table:

- t<sub>-4</sub>      Verify that proper tape is actually loaded on proper unit. If not, notify local operator (entry in Q<sub>4. c</sub>).
- t<sub>-3</sub>      If tape still not loaded, notify IFCS (Q<sub>4. b</sub> -- highest priority).
- t<sub>-2</sub>      Transfer routine to memory. Verify routine. Enter availability of routine in Q<sub>5</sub>.
- t<sub>-1</sub>      Verify that block of acquisition data has been received. Notify IFCS if not. Start processing data and store first block.
- t<sub>-0</sub>      Present first data to antenna (Q<sub>4. a</sub>). Set time for next set of data in time table Q<sub>16</sub>.

Ordinary processor P<sub>5</sub> will actually consist of a multiple set of constantly changing routines. The Q<sub>5</sub> queue table will include:

---

\*The IFCS is referred to throughout this section, although the information transmitted by (or via) the IFCS may originate at the GRCC or at MCC or LRCC.

Which routines have been brought into memory

Where they begin; i. e. , how to enter them

Where the basic acquisition data associated with each is stored (If the data has not yet been received, then that is also noted)

The output address for each set of data; i. e. , which antenna receives the data

A computed block of data for each mission together with appropriate times (The addresses and times for each set is stored in  $Q_{4, a}$ .)

An indication of simulation test

Priority of target position information.

The ordinary processor  $P_5$  can be requested in several ways ( $P_5R$  set): when routine has been brought into memory and basic acquisition data received and the output address stored; or when the next to last item of block has been used; or by IFCS command when acquisition data is revised.

Whenever  $P_5$  is requested and is reached from the priority table, the queue table will be searched. The particular block needing new data will be located, the calculations performed, and the block filled. When all such blocks have been filled (other partial blocks are ignored), then  $P_5I$  is turned off and control returned to the priority search routine.

Trapping requests for acquisition data might occur in several ways:

The antenna might be synchronized with the station clock and initiate traps at fixed intervals when data is needed.

A search of time table could indicate when outputs are due.

A time of next trap could be set into the time trap buffer. When the trap occurs, the table is searched to set the time of the next trap and the action (or actions) associated with that time are then performed. The  $P_5$  queue table would be searched and all data sets associated with that

particular time removed. If any block of data has only one set of data left, then  $P_5R$  is set.

After fetching the data set(s) the following action will be taken:

If lock-on has not been achieved, then output data to appropriate antenna.

If lock-on has been achieved, determine difference between actual and expected position, identify with mission and time, and inspect priority.

- If Class A, place with appropriate stored Class A telemetry data for transmission.
- If Class B, place with stored Class B data.
- If Class C, store on magnetic tape.

If data is flagged for simulation, identify and store for delayed transmission according to appropriate priority (probably Class B/lowest priority mission).

It should be noted that while this is a discussion of  $P_5$ , many of the operations described will actually be performed by  $P_4$ .

#### 7. ORDINARY PROCESSORS $P_6$ , $P_7$ , and $P_8$ (TELEMETRY DATA)

These three processors will be discussed as a group. They are separated into three for priority purposes. It is anticipated that this is the major processing load for the computer and as overloads occur, first  $P_8$  and later  $P_7$  will be delayed. The design load for a station will be selected so that for the maximum possible load,  $P_6$  can always be performed and the majority of requests for  $P_7$  can be processed.

The mission oriented subroutine associated with each of these are transmitted from the MCC (via an IFCS), and are stored, checked out, restored, called up, checked by simulation, identified, changed, etc., in the same manner that acquisition routines and data are entered into the computer.

The three processors are  $P_6$  (extract, identify, and store telemetry data),  $P_7$  (process Class A data, identify and store), and  $P_8$  (process Class B data, identify, and store). Each of these processors consists of a

set of mission-oriented subroutines and even while telemetry data is being processed for one group of missions, additional subroutines may be added to the group.

The handling of large volumes of telemetry data is undoubtedly the most complex task the station must face. Over and above the actual processing of data, problems associated with noise, data dropouts, synchronization, interference, mission identification, etc., must be considered and solved. In describing the  $P_6$  processor we are assuming that many of these problems are taken care of by equipment external to the computer. Specifically, data is made available in telemetry input buffers. Noisy signals are identified with possible "error" bits.

If data reception is lost, then a "flywheel" oscillator will continue to insert error bits to minimize resynchronizing of data.

Because of the possible high bit rates for telemetry, not all data will enter the computer. Instead, an external selection device will extract words, under computer control, for entry into the computer memory. Frame synchronization for subcommutated words will be established within the computer, and prime frame synchronization will be established external to the computer. Telemetry extraction control words will be output in blocks, and telemetry data so selected will be input in blocks. Analog data will be sampled under computer control. Based upon a prestored schedule, the analysis of previous data or instructions from the MCC, the sampling rates or selected words can be changed. Processor  $P_6$  will identify the data and separate Classes A, B, and C. Although provision for Class C data has been made, it may not be needed. This provides for storing telemetry data not needed in real time, but which might be requested after the pass. Thus, this data could be recovered without rerunning predetection or postdetection telemetry recordings.

A queue table associated with  $P_6$  will include the following:

- Which routines have been brought into memory
- Entry point
- Indication of synchronization (for subcommutation)
- The telemetry input buffer associated with each routine

- Addresses of stored raw data associated with telemetry buffer.
- Address of selection control words
- Mission priority (lowest priority will usually indicate a simulation test rather than an actual mission).

The traps associated with telemetry input buffers will store the blocks of raw data with an indication of time and trap number and will enter the address of the block in the  $P_6$  queue table. It would then request  $P_6$  (set  $P_6R$ ) and return to priority table search. The  $P_6$  processor will search the queue table and will pull out the oldest data first, without regard to mission priority. The trap identifier will denote which subroutine to use. If subcom sync has not been established, then data will be searched for the beginning of the subframe. Blocks of subcom data will be ignored until the beginning has been found. When the start has been located, words will be counted, and selected words stored either in the Class A data group or the Class B data group. The beginning of each block of A or B data will be identified with the time, mission number, and frame number; and the address of the block together with time and priority number entered into the appropriate queue table of  $P_7$  or  $P_8$ , and these processors will be requested. As long as addresses remain in the  $P_6$  queue table, this process will continue. When all data has been processed, then  $P_6I$  will be turned off and control returned to priority table search.

When  $P_7$  is requested, then this means that raw Class A data is ready for processing. Class A data is data which is desired in real time; Class B may be delayed while Class C must be preserved, but need not be transmitted until specifically requested. The  $P_7$  queue table contains the storage locations of all extracted Class A data together with the time of the data and the mission priority. The oldest data for the highest priority mission in the table is always processed first. Processing in the sense used here is really partial processing. It might involve calibration of data, comparison with selected or previous values, or some form of data compaction. The only limitation when selecting the type of processing is the amount of time available for computation. In general, it is assumed that the level of computation is aimed at

compressing the data and that final processing and analysis will take place at the MCC. As blocks are processed, they are stored with identifying codes (time, mission number, frame number, etc.) and the storage address, together with time, destination, priority, and class, stored in  $Q_{4,6}$ . Next  $P_4R$  is set. When  $P_7$  or  $P_8$  are processing raw data, a suppress bit associated with the data block is turned on to prevent transmission of such data by  $P_4$ .

When all data in the  $P_7$  queue table has been processed, then  $P_7I$  is turned off. The processing of Class B data by  $P_8$  continues in a similar fashion.

As previously mentioned, all Class A data will be transmitted before any Class B. Also, all higher priority Class A will be processed and transmitted before any lower priority Class A data. If communication lines can handle more data than the computer can process, then raw Class A data will be selected from  $Q_7$  and transmitted to reduce the processing load, provided the suppress bit is not on.

Thus, this procedure insures that maximum advantage of both communication line and data processing capacity will be maintained. If the computer cannot process the load as fast as it comes in and as fast as the communication line can transmit, then the processing load will be partially reduced by the transmission of extracted raw Class A data.

One additional set of procedures is needed to take care of the situation where both communication line and data processing are overloaded. The first squeeze will come on Class B raw data. When the backlog has exceeded a certain limit, new Class B raw data will be entered into the  $P_4$  queue table with a destination to a particular magnetic tape unit and this overflow condition noted. In a similar fashion, when the backlog occurs in the processing of Class A data, selected blocks will be sent to magnetic tape, but only the lowest priority missions. This will usually relieve the situation since this can effectively reduce the number of missions being processed in real time. If the backlog exists at the communication line (perhaps because of a line failure or reduced capacity), then temporary storage of processed data will take place. In each case, an entry in the appropriate queue table signals

that emergency storage has taken place, and such data will be recovered and forwarded according to the basic priorities. Since such data should be processed on a first-in, first-out basis, drums or disc files would be preferable to tape for this purpose. An alternate might be a two-headed tape recorder with a loop and a storage bin.

When  $P_7$  runs out of raw Class A data to process, if such data has been stored, it will be returned for processing. When all Class A data has been processed, then, in like manner, stored Class B data will be brought back into the computer for processing. Analyzing the comments which have been made about the ordinary processors  $P_6$ ,  $P_7$ , and  $P_8$  it should be noted that a portion of each can be considered as "permanent" routines. The mix of different types of missions is obtained by calling up various specially programmed subroutines within the framework of the ordinary processors. A substantial amount of the programmed control is identical for all missions.

As previously implied, simulation exercises are introduced into the computer as though they were regular missions. A specially prepared simulation tape could be read into a telemetry input buffer and processed in the normal manner. By assigning to such exercises a sufficiently low priority, normal missions would not be hampered; but by making such simulations deliberately overload the system, the data processor could be thoroughly exercised and tested.

Each message received by the IFCS is identified. While some additional processing and/or formatting may take place, in general, the message will be immediately forwarded to the proper MCC. To provide for uniformity of messages at the MCC, the IFCS may complete the processing if any raw data is received.

#### 8. ORDINARY PROCESSOR $P_9$ (STATION CHECKOUT)

Ordinary processor  $P_9$  is a set of routines that can check out (or direct the local checkout) of various parts of the station. Any portion or all of the available routines can be called up by the IFCS, the GRCC, LRCC, or the local operator.

It is visualized that the local operator will have a special keyboard with a set of coded overlays. Selecting an overlay and depressing a key

will create a trap which in turn will set  $P_9R$ . By this means, the operator can request a wide variety of tests to aid him in routine inspections and corrective maintenance. The IFCS, the GRCC, and the LRCC may not only call up the checkout routines and request transmission of results, but may modify the priority of  $P_9$  by placing suppress bits ( $P_iS_9$ ) in higher priority processors. For this reason, whenever  $P_9$  is completed, it will always remove the  $P_iS_9$  bits from all other, higher priority routines.

#### 9. ORDINARY PROCESSOR $P_{10}$ (COMPUTER CHECK)

While  $P_{10}$  could well be part of  $P_9$  and is certainly included in  $P_{15}$ , it appears desirable to be able to insert a very fast computer check at intervals in the operation without checking the remainder of the system.  $P_{10}R$  could be set by time traps, by malfunction traps (overflow, parity error, etc.), by local operator command, or by IFCS, GRCC, or LRCC instruction. As with  $P_9$ , the priority could be raised; hence,  $P_{10}$  will always remove  $P_iS_{10}$  bits from higher priority processors.

#### 10. ORDINARY PROCESSORS $P_{11}$ THROUGH $P_{14}$ (MISCELLANEOUS)

These processors will take care of miscellaneous functions which may be required of the station. Typical programs could include:

Maintaining employees' time records for payroll purposes

Special equipment calibration procedures

Keeping track of spare parts inventory and indicating potential critical shortages

Allocating costs of station operations to different missions

Verification of routines previously stored

Other routines as inserted by GRCC, LRCC, IFCS, MCC, or local operator.

Here again, the priority of any routine in this group may be modified.

#### 11. ORDINARY PROCESSOR $P_{15}$ (DIAGNOSTIC)

This is a general diagnostic routine which is performed when no other tasks are presented to the computer. At intervals  $P_{15}$  could set  $P_9R$  and sequence through all possible station checkout procedures.

## F. SUMMARY

The preceding comments have attempted to describe a flexible adaptive control program for an instrumentation station. It should be recognized that this is a first attempt at describing a workable system capable of balancing processing and communication loads, and coping with a varying problem mix. Some portions have been described in detail. Other functions were more casually treated, either because minor modifications of the same techniques were applicable or because the actual implementation, while complex, was relatively straightforward.

To avoid misunderstandings with regard to what has been attempted here, an earlier comment will be repeated. The routine described here ignores the formidable problems of the actual methods of processing telemetry data, acquisition data, checkout, etc. These problems must and will be analyzed; however, they are mission-oriented problems which must be solved for each mission, or at least each type of mission.

The routine discussed and developed here permits a more accurate estimate of instrumentation station computer requirements and forms the basis for analyzing the IFCS and GRCC processing requirements.

## Appendix XXVIII. COMPUTER INTERFACE FOR TELEMETRY DATA

### A. GENERAL DESCRIPTION

#### 1. INTRODUCTION

The telemetry-computer interface equipment has been selected to provide a near-optimal means of terminating, extracting, and forwarding telemetry data words to a computer. The primary purpose of the configuration is to:

- Remove from the computer the burden of handling the high input data rates
- Provide to the computer, with minimum computer effort, the extracted data in a defined sequence in a computer-compatible format
- Provide means, during the mission, of easily modifying the quantity and type of data being extracted
- Provide an interface which is economical, has a reliability equal to that of the computer, and a flexibility equal to that of the data link. (Figure 1 presents the general equipment configuration.)

In the area of equipments necessary to extract telemetry words, two alternative designs have been developed. These are described in Sections C. 2 and C. 3 of this appendix. The method described in C. 2. is suitable for an operation where many words are to be extracted from the frame of data, preferably the same words from each frame; while the method described in C. 3 is more suitable where slow-speed computers are used and where few, but different, words are needed from each frame.

#### 2. SYSTEM CONCEPT

Variability in telemetry characteristics for input to ground-based equipment should be allowed sufficient freedom such that objectives of the mission can be totally realized, design restrictions on the space telemetry systems are minimal, and available bandwidth is fully utilized.

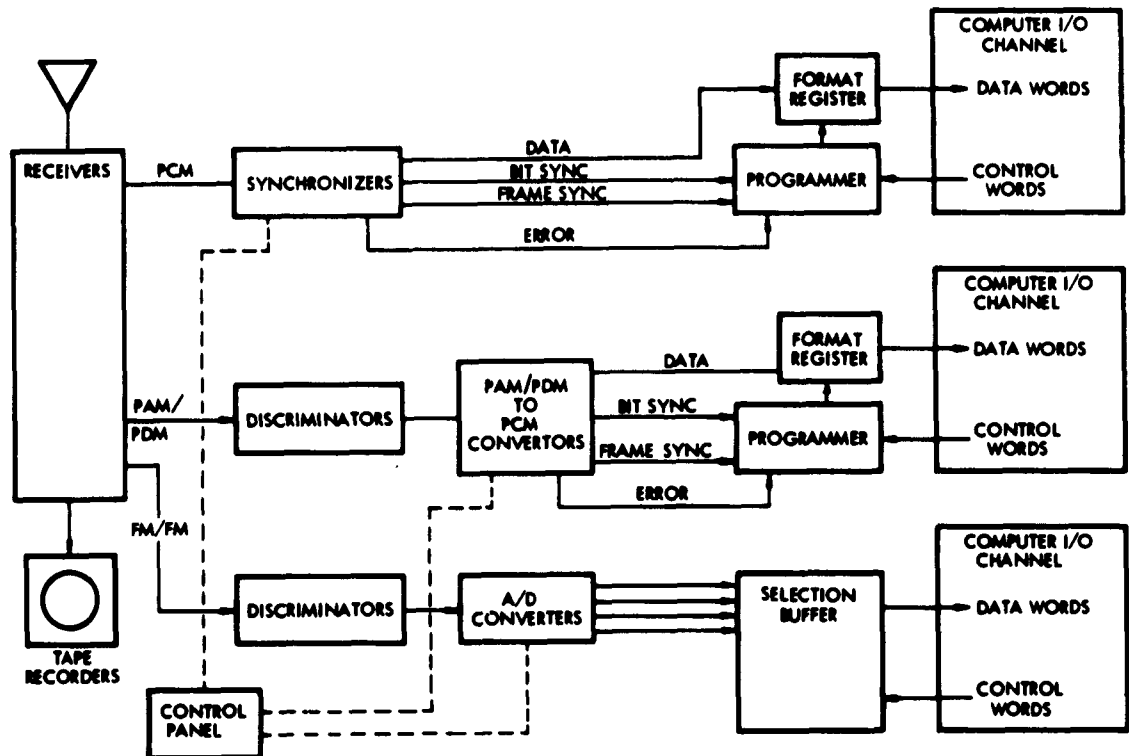

Figure 1. Data Process Interface

The primary areas of variability which must be considered in the receiver-computer interface mechanism are:

- Area 1. Required demodulation techniques; required signal-to-digital conversion techniques; synchronization techniques.
- Area 2. Data rates; signal stability characteristics; frame size.
- Area 3. Quantity of data required in real time; word length; subcommutated and supercommutated channel characteristics.

These three areas have general characteristics which can be related to equipment requirements. Area 1 characteristics are generally associated with fixed characteristics of the terminating devices dictated by type of transmission, reliability levels, and economics. Area 2 characteristics are generally variable between missions and remain fixed during a pass or mission. These may vary during a mission in more

advanced space systems. Area 3 characteristics vary during the mission from time interval to time interval, and from channel to channel.

The control functions involved in these three areas should be performed by the method that involves the minimum complexity and provides the required flexibility. It is, therefore, proposed that Area 1 variations be performed by manual insertion of the appropriate equipments with input/output assignments made by switch or plug panel techniques. Area 2 variations are handled primarily by patch panels or stored program memory systems with the facility for the addition of automatic logic to switch between several preprogrammed patch panels or memories under computer control.

Area 3 variations have the most exacting speed and mode switching requirements since these variations may be the result of real time computations and decisions. Also, variations in word length and characteristics of subcommutation may vary from word to word (channel to channel) in the same frame, requiring a computer-type control mechanism for the appropriate extraction of the measurement or signal. In this area, the equipment proposed is a simple mechanism referred to as a programmer-format register; the control over this device is rigidly tied to the internally stored computer programs via suitable computer input/output channels. It serves to assist the computer in handling the assignments in Area 3, by removing the burden of the high input bit rates and the required repetitive logic level subroutines associated with the word extraction process. Since it is a normal requirement that only a small percentage of the data need be extracted for real-time processing by a computer, this mechanism can greatly increase the available processing capability.

From a data flow viewpoint, the system involves receiving telemetry data in any form, converting this data to a serial digital bit stream, processing the bit stream, bit by bit, under program control, registering the data in its desired format, and transferring this parallel data via a computer input channel to the allocated storage area in the computer. The system flow, up to and including the formation of the serial bit stream, is mechanized by the equipment concerned with Areas 1 and 2.

The processing of the bit stream is handled by the programmer-format register. Its capability is related to the computer capability

since minimum buffering is recommended. The equipment itself is capable of accepting any number of bits per word, any number of words extracted for transfer to the computer, any number of words per frame, and a bit rate of 1 megabit/sec.

The detailed implementation of this concept is described in Section C.

## B. INPUT AND OUTPUT FUNCTIONAL SPECIFICATION

### 1. INPUTS

#### a. Data rates

Data rates are as follows:

- PCM bit rates from 8 bits/sec to 1 megabit/sec shall be accommodated by the system.
- PAM data rates corresponding to a range of 1 sample/min to 100 samples/sec shall be processed by the system. PDM channels are converted to equivalent PAM signals and are processed by the same equipment with the same range of data rates.
- FM/FM channels having a frequency response from zero to 2 kc shall be accommodated by the system.

#### b. Data Formats

##### 1. PCM

Bit formats shall include split phase, bipolar, and the various minor forms of NRZ and RZ. Frame format shall consist of any number of words up to a maximum number of bits per frame equal to 2048. Word size shall be unlimited down to one bit. Upper limit word size shall be 64 bits. Any number of subcommutated channels in any format shall be accepted. Subframes shall be any length up to a total of 2048 bits.

##### 2. PAM and PDM

PAM sampling format shall be NRZ or RZ with a frame and subframe length from 1 to 130 samples. PDM formats within the range assigned to PAM shall be accommodated by the system.

### 3. FM/FM

FM/FM are continuous analog channels with one measurement per channel. From 1 to 18 channels shall be accommodated.

#### 2. OUTPUT

##### a. Data Rates

The output data rate to the computer will be primarily controlled by the computer processing capability. The interface equipment shall be capable of delivering words at the input rate without any restrictions on the high- or low-speed ends of the rate spectrum.

##### b. Data Formats

The output data to the computer shall be presented in a form compatible with the input channel characteristics of the computer.

#### 3. CONTROLS AND INDICATORS

Controls and indicators are primarily associated with malfunction, since station personnel are primarily involved with equipment maintenance and not with the operational characteristics of the mission. All equipments are modular for rapid replacement in the event of failure.

Changes in equipment requirements from mission to mission are facilitated by semiautomatic controls which can be easily defined by means of verbal or teletype printer instructions. These include changes such as frequency, formats, and number/types of communication links.

#### C. DETAILED DESCRIPTIONS

##### 1. TERMINATIONS AND CONVERSIONS

##### a. PCM

The equipments associated with the PCM links are the bit synchronizer, signal conditioner, and frame synchronizer. The bit synchronizer synchronizes to the serial PCM bits present at its input and provides a stable bit sync clock for use in the signal conditioner, frame synchronizer, and the programmer-format register. The signal conditioner reconstructs the serial PCM bits present at its input and provides a noise-free replica of the input signal at its output. This output in serial form is transmitted to the programmer-format register and the frame synchronizer.

Currently available PCM terminating equipments are suitable for operation in this system; however, particular mission requirements may necessitate the use of computer-controlled switching of frame and bit synchronization parameters.

b. PAM and PDM

Pulse amplitude-modulated and pulse duration-modulated links require equipment to discriminate, normalize, detect transitions, generate pulse and frame sync, and convert the analogue PAM-PDM signal to PCM. After conversion to PCM, the serial bit stream is transmitted to a programmer-format register and is processed in the same fashion as the PCM inputs.

This method minimizes the variety of computer interface equipments and simplifies the programming of data extractions in real time.

c. FM/FM

The FM/FM processing equipment consists of demultiplexing discriminators, analog-to-digital converters, and a selection buffer under computer control. Since the data provided is a continuously present measurement, the computer can call in a particular line at its own sampling rate, thereby relieving the real-time program of timing restrictions. Currently available equipments are suitable for use here. The selection buffer is an elementary logic device which interfaces the computer, stores a selection control word, decodes the control word for selection of the FM/FM channel converter, and is a single word buffer for storage of the measurement.

d. Block Diagrams

Figure 2 provides a simplified block diagram of the PCM, FM/FM, and PAM-PDM systems.

2. PROGRAMMER-FORMAT REGISTER

a. Block Diagrams

See Figures 3 through 6.

b. Block Definitions

Figure 3 represents the entire programmer format register. The five primary logic blocks consist of:

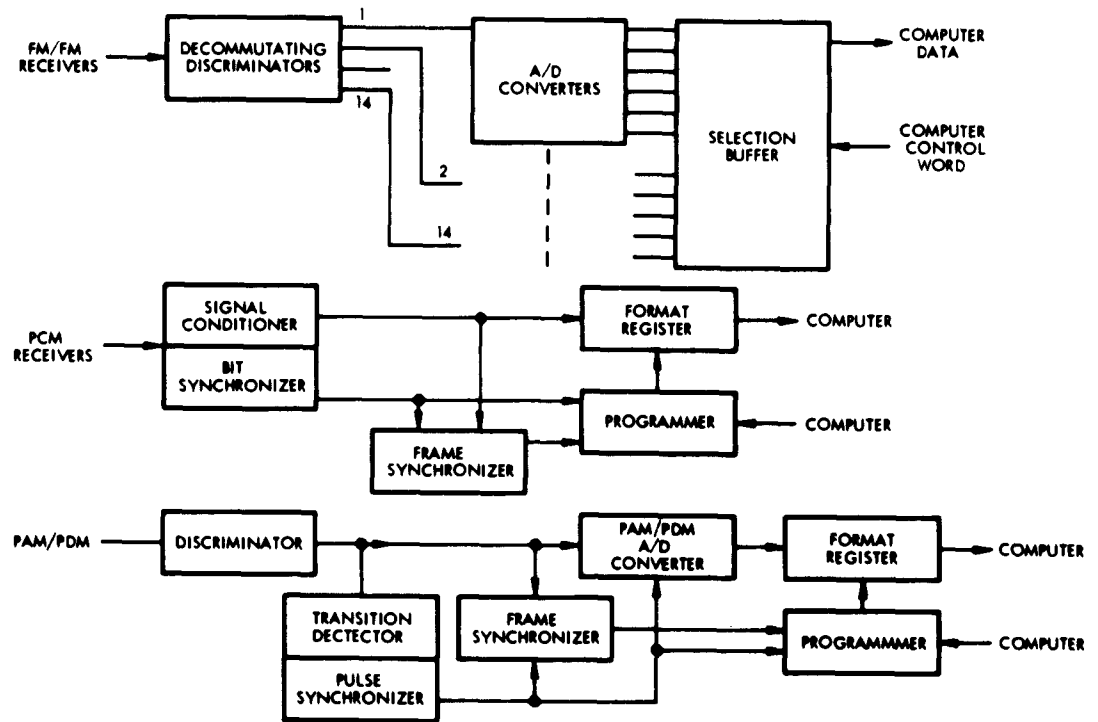

Figure 2. PCM, FM/FM, PAM-PDM System - Simplified Block Diagram

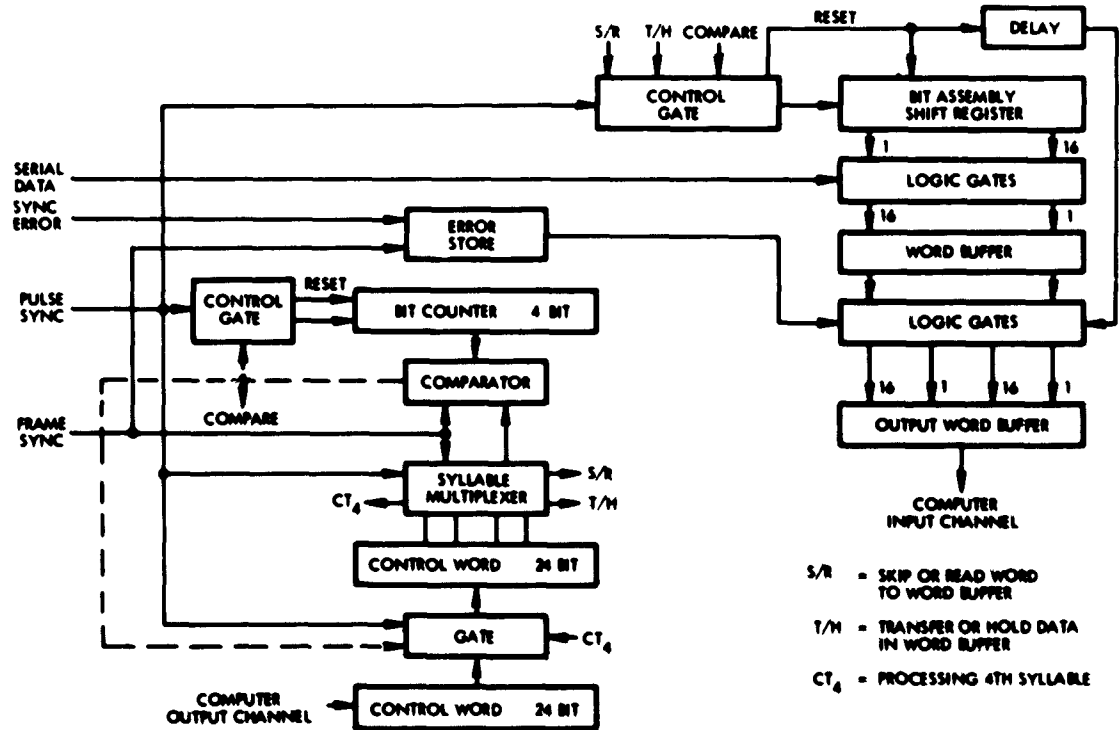

Figure 3. Programmer and Format Register - Simplified Block Diagram

Control Word Buffer. The control word buffer consists of two 24-bit registers which buffer a single 24-bit word between the computer output channel and the internal mechanism of the programmer. The control word consists of four "syllables" which, when decoded, control the extraction and forwarding of one or more telemetry words. The syllable consists of

- Four bits: Number of bits to be extracted or skipped from 1 to 16
- One bit: Skip the bits or read the extracted bits into the word buffer
- One bit: Transfer or hold the extracted bits in the word buffer. This assists in forming the word or words in the output data buffer which interfaces the computer. (Maximum word size is 32 bits.)

Bit Counter. Bit counter and comparator form a logic block which counts the bit sync from the telemetry signal conditioner or conversion equipment and compares this count with the 4-bit binary code held in the syllable. Each time the count agrees with the syllable code, a "compare" signal is generated which gates the next bit sync to the reset side of the bit counter. This "compare" signal is used throughout the programmer-format register to define the start of a new group of extracted or skipped bits.

Syllable Multiplexer. The syllable multiplexer (Figure 4) counts the "compare" signals and gates successive syllable data from the control word. The 4-bit syllable code is gated to the comparator, while the "S/R" and "T/H" bits are gated to the format register. During each period in which syllable number four is gated, a "CT<sub>4</sub>" signal is generated, which allows the control word buffer to transfer forward on the next "compare" signal and pulse sync.

An additional circuit included in the syllable multiplexer is provided to assure synchronization of the computer with primary frame sync. The OR GATE and INV decode the T/H and S/R bits and inhibit counting until the frame sync pulse arrives. Every first syllable of the program, for a frame, contains the bit condition "S/R = 0" and "T/H = 1."

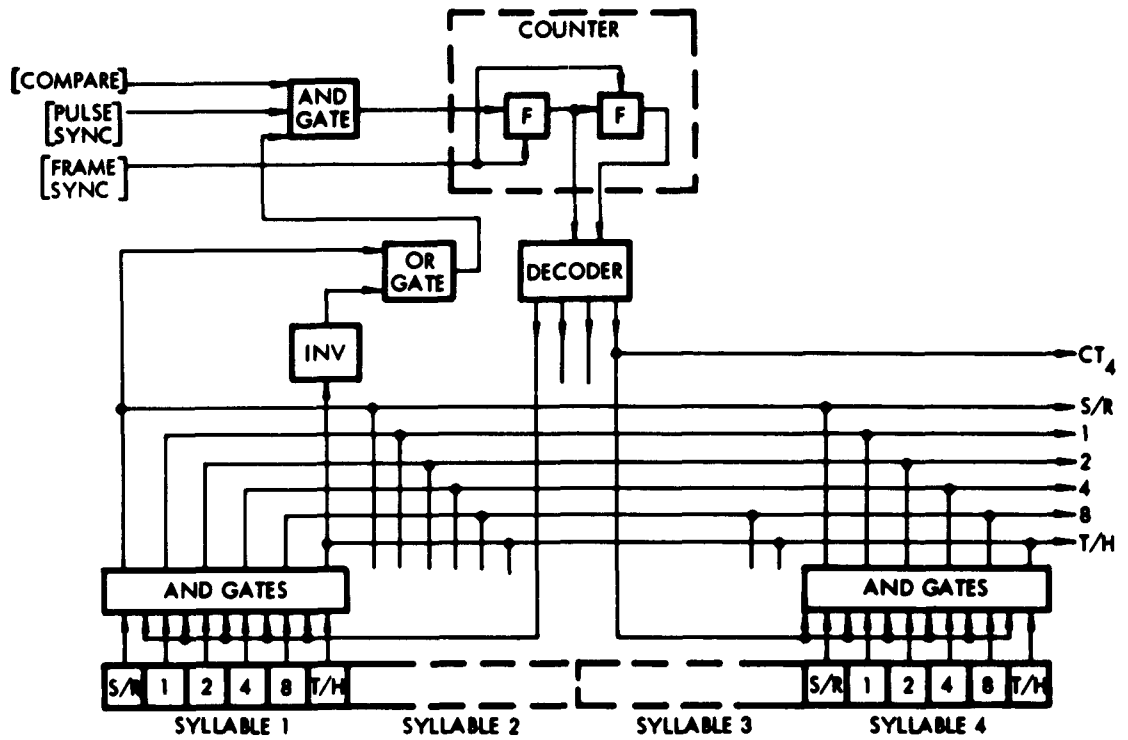

Figure 4. Syllable Multiplexer

With this condition present, no data is accepted and no transfers are initiated until frame sync arrives and steps the syllable multiplexer counter.

The decoded "S/R" and "T/H" bits have the following values:

<u>S/R</u>	<u>T/H</u>	<u>Value</u>
0	0	SKIP
1	0	Read and hold word
1	1	Read and transfer word
0	1	Skip and wait for frame sync

Bit Assembly Shift Register. The bit assembly shift register (see Figure 5) accepts data, which are to be extracted, in serial form and assembles the bits in a parallel register in a normalized form. Binary digit "1" always appears in register position 16. Each control word syllable contains a "T/H" bit which indicates whether or not the extracted bits should be transferred to the output data buffer. If the extracted bits

represented by one syllable are to be transferred, the next "compare" signal gates the word (1 to 16 bits) into the first or second half of the output data buffer. At this time the shift register (Flop 1-16 of Figure 5) is reset so that Flop 1 is set, and all others are reset. As the next extracted bit arrives, the data is set into the word buffer position 16 and Flop 2 is set by logical shifting, and all others are reset. This process continues for the entire word. If the control word syllable does not contain "T/H = 1" and "S/R = 1," then the shift register does not reset and subsequent bits are packed into the word buffer up to 16 bits.

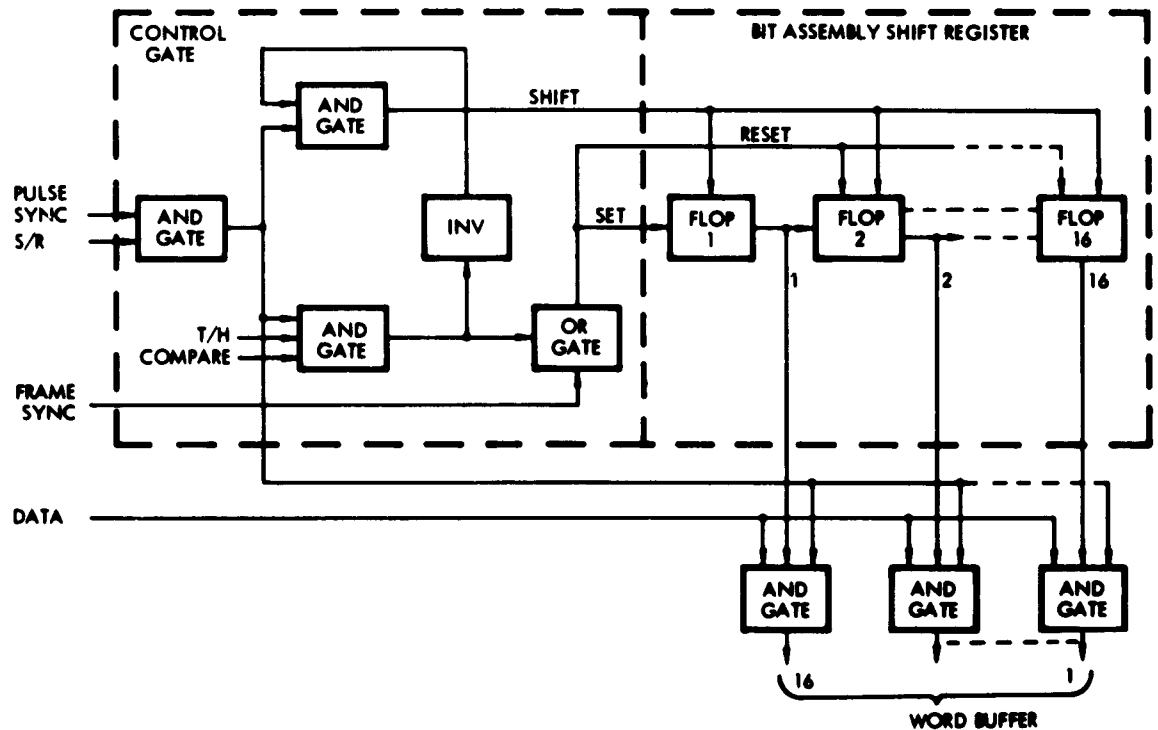

Figure 5. Bit Assembly Shift Register and Controls

Data Word Buffers. The data word buffers consist of a 16-bit word buffer and an output data buffer (maximum 32 bits) with the appropriate transfer and clear controls. The 16-bit buffer is tied to the bit assembly shift register and stores the assembled bits until the "T/H" bit indicates a transfer. The bits extracted at this time are transferred

into the output data buffer. After the output data buffer has received two half-word transfers, the data is transferred to the computer in the form dictated by the computer input channel characteristics.

Associated with the data word buffers is a means of indicating to the computer, through its normal input channel, that the synchronization of input telemetry signals is in error. When the channel synchronizer loses sync and data may be in error, the synchronizer unit will provide a signal to the programmer to set an error flop. On the next word transfer (when T/H and S/R are both binary "1"), a marker character will be placed in the output data buffer register (possibly all "1").

The computer program will perform this character check as the data is being extracted from memory and treat all subsequent data as suspect until the end of the frame.

The error flop in the programmer will be reset by the next frame sync pulse. If the error signal from the synchronizer is still present, the procedure will be initiated once again.

c. Control Word Programming

The method of programming of control words is dependent on:

- Input data rate
- Computer input-output rate
- Quantity of data to be extracted
- Word size.

Each control word (Paragraph C. 2. b) contains four syllables which control the extraction or skipping of 1 to 16 bits. The number of bits processed by these four syllables must have a total time period equal to the time required by the computer to output one 24-bit control word and accept as many telemetry words as are extracted in the four syllable sequence.

The exact time at which the control word is outputted is not critical, since a four syllable buffer is supplied. The acceptance of a data word by the computer input channel is also buffered and has, on the average, two syllable times to initiate the transfer.

The syllable contains 4 bits which specify the word length of 1 to 16 bits: 1 bit (S/R) which indicates whether to skip the data or read into the buffer, and 1 bit (T/H) which specifies whether or not the word is complete and can be transferred to the output data buffer. A typical sequence of orders would appear as follows:

<u>Word</u>	<u>Syllable</u>	<u>Instruction</u>	<u>Code</u>		
			<u>S/R</u>	<u>1248</u>	<u>T/H</u>
1	1	Read word of 8 bits and load output data register	1	0001	1
1	2	Skip word of 12 bits	0	0011	0
1	3	Skip word of 1 bit	0	1000	0
1	4	*Read word of 12 bits and load output data register	1	0011	1
2	1	Read word of 1 bit and hold in word buffer	1	1000	0
2	2	Read word of 1 bit and transfer to output data register	1	1000	1
2	3	Skip word of 16 bits	0	0000	0
2	4	Skip word of 16 bits	0	0000	0
3	1	Skip word of 16 bits	0	0000	0
3	2	Skip word of 8 bits	0	0001	0
3	3	*Read word of 8 bits and transfer to output data register	1	0001	1
3	4	Skip word of 16 bits	0	0000	0

\* Initiates transfer of output data buffer to computer, since two word transfers have been made to output buffer.

#### d. Interconnections and Controls

Three areas are involved in the equipment necessary to interconnect and control the programmer-format register. These are:

- Data input controls
- Computer interface
- Maintenance controls.

On the input data side of the device, quick-connect/disconnect jack panels are provided to replace signal conditioners, A/D converters, synchronizers, etc. Minimum signal line requirements for input are:

Serial data line  
Bit sync line  
Frame sync line/lines  
Error line/lines.

Since the device is operable at any bit sync up to one megabit per second no other controls are required to patch in a new terminating device.

On the computer side, a more permanent connection can be used. However, the equipment required to match the computer channel characteristics must have the ability to provide the required transfer control lines and word size. To make the device general purpose, a simple patch panel connects the appropriate lines.

The simplicity of the programmer-format register allows the use of an elementary maintenance panel consisting of register indicator lamps, sync interrupt switch, and set-up switches for a control word syllable.

e. Timing Example

Table I and Figure 6 provide a detailed example of the logic circuit timing for a representation sequence of control word syllables. The logic is synchronous with the input bit sync and is capable of handling sync jitter of  $\pm 25$  percent at 1 mc. All counters and registers are set and reset at bit sync time. Those registers and counters, which are cyclic and return to a given value on application of a reset pulse, have input gates which steer the normal shifting or counting pulse to the reset side at the appropriate time. Logic circuits in the 3-mc range are used.

Table I. Programmer and Format Buffer Timing Example

<u>Control Word No.</u>	<u>Syllable No.</u>	<u>S/R 1 = Read</u>	<u>T/H 1 = Transfer</u>	<u>Bits/Word 1 to 16</u>	<u>Binary Code</u>
3	8	1	0	11	10
3	9	1	1	1	0
4	10	1	0	1	0
4	11	0	0	1	0
4	12	1	0	1	0
4	13	1	1	9	8

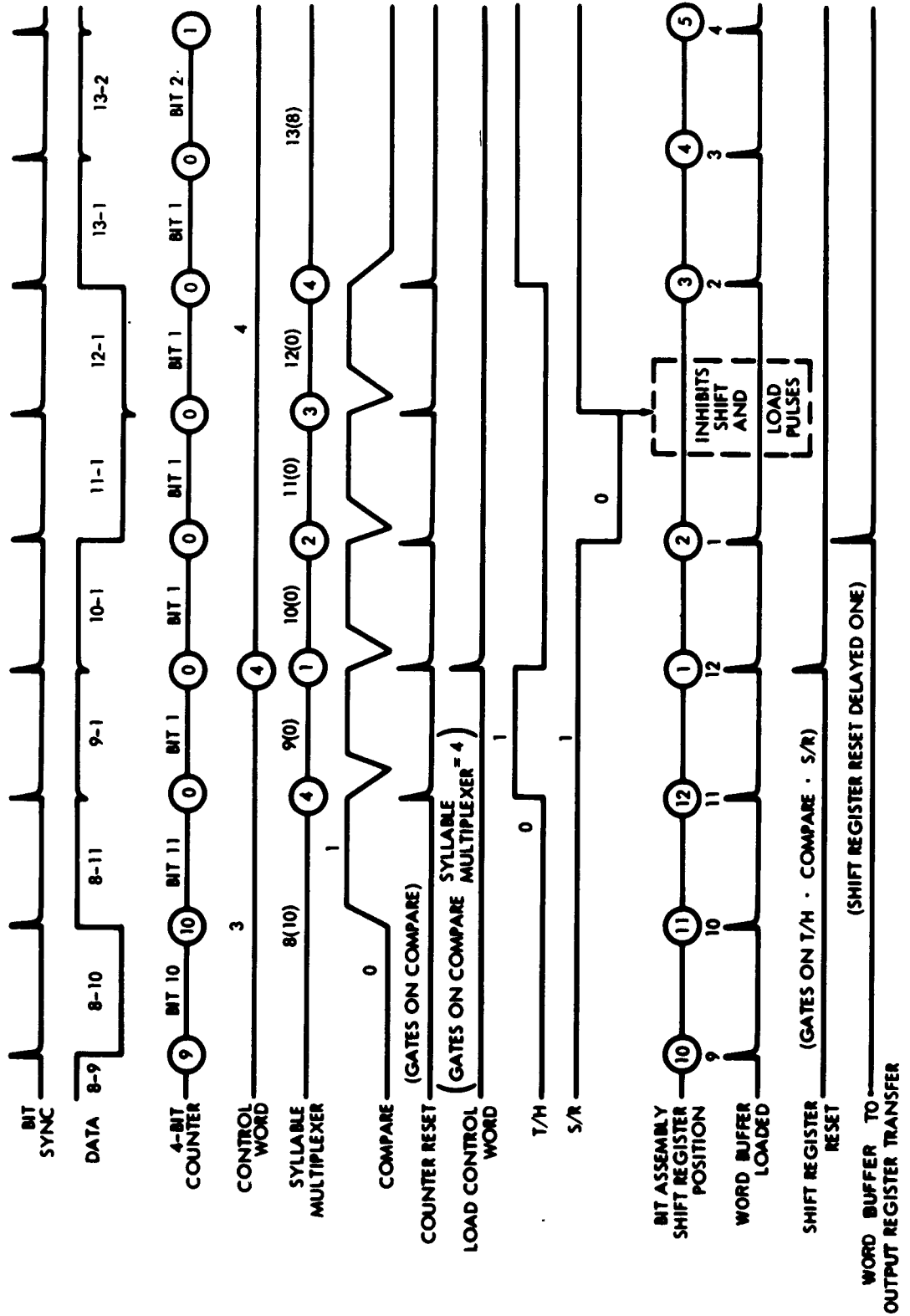

Figure 6. Timing Example

### 3. ALTERNATIVE PROGRAMMER

#### a. Concept

Since the programmer is an inexpensive device of few logic elements, it is feasible to envision more than one device which has the capability of being quickly patched into the system to accommodate a particular mission or equipment situation.

For example, consider a vehicle with several one megabit/sec PCM links feeding a relatively slow ground computer. The real time data processing requirements in any one frame time must necessarily be a very low percentage. If, for example, this is two or three words per frame time, then a more ideal solution in processing of the bit stream would be a mechanism which has the capability of skipping many serial data bits after the exiting of a single control word from the computer (in other words, a control word which skips many bits until the word to be extracted is obtained). In this way, only one control word is required for each word to be extracted in the particular frame time. This opens up the possibility of storing in the computer a series of control words for a sequence of frames, extracting different words from each frame with minimum control word storage and minimum time for outputting.

#### b. Control Word

In this system, the control word of 24 bits which defines the serial bit stream processing consists of:

Seven program bits

Seventeen bits for reading or skipping.

The control word can execute four sequences of reading and skipping. The sequence is determined by bits 1 and 2 of the seven program bits. If bits 1 and 2 have the value of:

"Zero"

Skip 1 to 2048 bits

Read 1 to 32 bits

"One"

Read 1 to 32 bits

Read 1 to 32 bits

Read 1 to 32 bits

"Two"

Skip 1 to 32 bits  
Read 1 to 16 bits  
Skip 1 to 16 bits  
Read 1 to 16 bits

"Three"

Read 1 to 32 bits  
Skip 1 to 2048 bits

Modes "one" and "two" are provided to ease the computer output requirements when the words to be extracted are more than two and appear close together in the frame. Two words to be extracted per frame can be handled easily since the control word has a 24-bit buffer for the second word extraction.

Modes "zero" and "three" provide the normal means of extracting a few words from a long frame.

The four sequences, of course, require that the 17 bits for reading and skipping have to be appropriately allocated for each mode.

<u>Mode</u>	<u>Skip Bits</u>		<u>Read Bits</u>		
	<u>Step 1</u>	<u>Step 2</u>	<u>Step 1</u>	<u>Step 2</u>	<u>Step 3</u>
Zero	11	-	5	-	-
One	-	-	5	5	5
Two	5	4	4	4	-
Three	-	11	5	-	-

The five remaining program bits are assigned as follows

<u>Bit</u>	<u>If bit = "one"</u>
3	Repeat control word once
4	The Read Operation (Step 1) has completed a half word. Transfer to output data buffer
5	Same as bit 4 except applies to Read (Step 2) for mode "two" and Read (Steps 2 and 3) for mode "one."

- 6            When output data buffer is empty (neither half-word has been loaded) load next half word into left half of buffer if bit 6 = binary 1
  
- 7            Wait until frame sync pulse occurs before starting bit processing sequence and counting.

c.    Hardware

Mechanization of this approach follows the methods used in the programmer described in Section C.2. Control signals and data paths to the format register are compatible. Data and computer inputs are the same.

Longer or shorter words can be easily accommodated by increasing counter and register sizes while maintaining logic and programming methods.

## Appendix XXIX. DATA COMPACTION

## A. INTRODUCTION

The data collection systems on the typical space vehicle or missile generate data at phenomenal rates: typically, several orders of magnitude faster than the capacity of computers, transmission systems, and display devices. For many applications, the data can be collected for later analysis; however, there are some applications where the data is needed in real time. (In this appendix, "real time" is applied to any process with a lag between data generation and collection that is not expected to grow with time.) For real-time systems, the data-rate must be reduced or compacted (on the average) to less than the capacity of the slowest link in the processing system. This link may well be the human interpreter of the data display (the bulk of psychological and physiological data seems to indicate that the upper bound of the ability of a human to process information is less than 50 bits per second). The problem is well illustrated by voice transmission systems: a channel capacity of approximately 50,000 bits per second is required to transmit unprocessed human speech with reasonable fidelity. A written transcription of the same data can be transmitted over a channel with less than 50 bits per second capacity. By taking account of the syntax of the language, the required capacity may be reduced to less than five bits per second. Taking account of the probabilities of whole messages, the rates (in principle) may be even further reduced.

In a similar manner, it is at least conceptually possible to compact engineering and scientific data by processing to extract only the information relevant to real-time action or analysis and coding this information in an optimum procedure. But optimum techniques are elusive for a variety of technical and economic reasons. Some of the limiting factors are: (1) the criteria for relevancy are often difficult to specify, (2) the statistical properties of signal and noise rarely are describable by classical linear-gaussian-stationary models, (3) practical techniques for the realization of theoretically derived optima are in many cases not

known, and (4) the problems of transmission reliability become more acute as redundancy is removed by data compaction techniques. As the compaction efficiency increases, savings in transmission capacity are often mitigated by increasing costs of the storage and computational capacity needed for the increasing complexity of computation. Another factor is the increasing risk of selecting the wrong information as the amount of data processing is increased. However, it is questionable that it is possible to avoid this risk in real-time systems in view of the disparity between typical telemetry data rates and the limitations of the human-observer data-processing capacity.

## B. METHODOLOGY

The essence of data compaction is the reduction of redundant and irrelevant information in data sources. Excess redundancy arises primarily from three factors: (1) lack of complete knowledge about a process, so that conservative instrumentation design must include capacity to transmit without distortion all possible forms the process may take, (2) lack of resources to effect significant data preprocessing (e. g., weight and power limitations, etc.), and (3) the necessity of performing subsequent fine-grain analysis which generally requires data of considerably greater resolution than that desirable for most real-time applications.

The methodology of compaction may be classified into four categories. The current state of the art of these techniques will be summarized and some applications and extensions proposed.

It is assumed in the following that the data to be processed is in digital time-multiplexed format.

### 1. EDITING

Editing for data compaction is the separation of data into two subsets: relevant (to be forwarded), and nonrelevant (to be ignored). The criteria for this selection may be deterministic (e. g., transmit every  $n$ th sample) or statistical (e. g., transmit only if the variation exceeds  $X$ ). Again the selection may be in time or frequency. Time selection is normally a straightforward task for the digital computer and requires very little

capacity. Frequency selection is somewhat more difficult, although very good numerical filters are known that require a constant computer effort per input point (three multiplications per unit) and are modest in storage requirements. Filtering allows a reduction of sampling rate to be accomplished without the hazards of aliasing.

Editing has a limitation in that the editing criteria (whether deterministic or statistical) need to be known a priori. A possible extension of editing is the use of adaptive criteria in which the computer "learns" to improve its performance as it processes data. To define the requirements in computer capacity made by this type of processing would need considerable study.

## 2. DATA REDUCTION

An alternate method of data compaction is the reduction of data volume by processing before transmission (preprocessing). Examples of this technique are the computation of statistical parameters (regression coefficients, moments, spectra, etc.), transmission of the difference from nominal, and functional combination of raw data into fewer derived quantities.

These techniques suffer from the disadvantage of the need to be tailored to each specific data source. Thus, required storage capacity in the computing system is large, and considerable computational power may be needed.

## 3. PATTERN RECOGNITION

An alternative data reduction technique is the classification of data into descriptive categories, and the transmission of the classification. Further, data reduction may be predicted on the pattern identification. For example, a simple classification scheme might be:

A = noiselike data

B = polynomial trend data

C = transient data

and a processing scheme based on a pattern identification might be:

If the data is in A, compute mean and variance over 1-second intervals

If the data is in B, compute the first 5 regression coefficients over 10-second intervals

If the data is in C, transmit the raw data at a rate of 500 samples per second.

If  $a_a$ ,  $a_b$ , and  $a_c$  are the expected relative times of occupancy of states A, B, and C, and  $k_a$ ,  $k_b$ ,  $k_c$  are the number of bits needed to describe the results of each parameter developed by A, B, and C, the expected data compression ratio  $\beta$  would be:

$$\beta = \frac{2 a_a k_a + 0.5 a_b k_b + 500 a_c k_c}{500 k_c}$$

$$= a_c + \frac{a_a k_a}{250 k_c} + \frac{a_b k_b}{1000 k_c}$$

In a like fashion, the variance of the data ratio could be determined. The expected amount and variance of computer processing load and memory storage needed would follow in a similar computation.

#### 4. CODING

Coding reduces redundancy by modifying the alphabet used to describe the data. The ultimate code is one that matches the capacity of the channel it is to be transmitted over--i. e., the optimum code contains sufficient redundancy to detect and correct transmission errors. In general, the redundancy inherent in data is usually excessive and not of a form that can be effectively utilized in error correction. Thus, the coding process consists of first applying a redundancy elimination scheme producing an output sequence whose length is minimized and then adding redundancy in an optimum manner to match the channel.

A procedure for generating this sequence is (theoretically) well known. It consists of forming a prediction,  $\hat{X}_i$ , of the data value,  $X_i$ , and encoding the difference,  $X_i - \hat{X}_i$ , into a minimal length comma-free

sequence. There are two practical difficulties that must be solved in any application: First, an optimum predictor is predicated on a knowledge of the statistics of the data. In the absence of this knowledge (which is the usual case for real data) the predictor is computed from the sample data.

Optimum general predictors require considerable computation capacity, so that the actual technique used is generally a compromise. Secondly, any error introduced into a minimum length code is catastrophic; i. e., no reconstruction is possible after error is introduced, which puts very severe restrictions on the subsequent data handling systems.

### C. DESIGN OF A COMPACTION SYSTEM

A possible computer processing system for implementing the techniques outlined above is diagrammed in Figure 1. The choice of specific hardware depends heavily on the specific data to be handled, as indicated in the example above. Even extremely simple assumptions on average rates require detailed information about the statistical properties of the data. For much of the data to be handled, these are not now known. Many tradeoffs are also possible in programming (e. g., degree of compaction versus storage requirements versus computational efficiency), and choice of hardware. These are all data-dependent, so it is not considered possible to design a universal compaction system with the current state of the art.

Therefore, the design of a compaction system would be preceded by the compiling of statistics on the properties of the data to be transmitted, particularly variability, predictability, and patterning possibilities. The number of different types of compaction techniques, their efficiency, and storage requirements also must be compiled before adequate hardware can be specified.

Data compaction thus consists of editing, data reduction, pattern recognition, coding, and recoding for error correction.

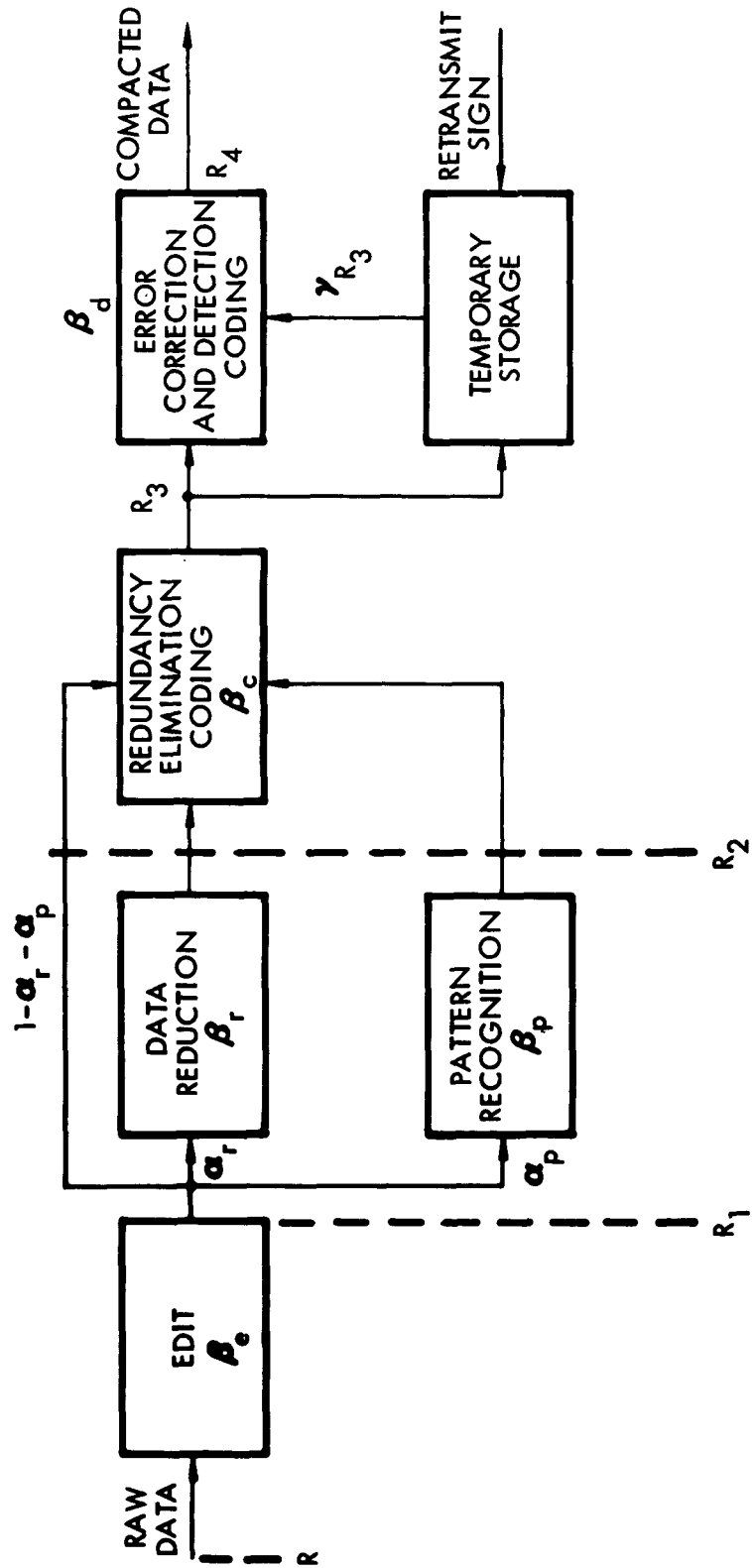

Figure 1. Typical Data Compaction System with Retransmission Capability

If the original data rate is  $R$  and the ratio of output information to input information is  $\beta_e$  then the rate after editing  $R_1$  is (from Figure 1)

$$R_1 = \beta_e R$$

after data reduction and pattern recognition,

$$R_2 = \beta_e R \cdot (1 - a_p - a_r + a_r \beta_r + a_p \beta_p)$$

after coding

$$R_3 = \beta_e \beta_c R (1 - a_p - a_r + a_r \beta_r + a_p \beta_p)$$

and if  $\gamma$  = the average fraction of data retransmitted,

$$R_4 = (1 + \gamma) \beta_e \beta_c \beta_d (1 - a_p - a_r + a_r \beta_r + a_p \beta_p)$$

The Shannon coding theorem applied to this context states that if  $R_3 < C$ , where  $C$  is the data transmission channel capacity, then a coding exists that will allow transmission over the channel with arbitrary small error probability.

#### D. COST CONSIDERATION

Although a compaction system cannot be costed without considerable research into the details of the data considered, some order-of-magnitude determination can be made for representative functions. The significant parameters for the determination of computation capacity are memory size (programs + temporary data), average rate of memory accesses, and average arithmetic computation rate.

Memory size requirements are determined by many factors that are both machine and data dependent. In general, memory size increases with the degree of compaction because of increased complexity of programs and longer spans of data required in memory both for adequate data reduction and for the increased coding efficiencies required. Figure 2 shows some typical relations.

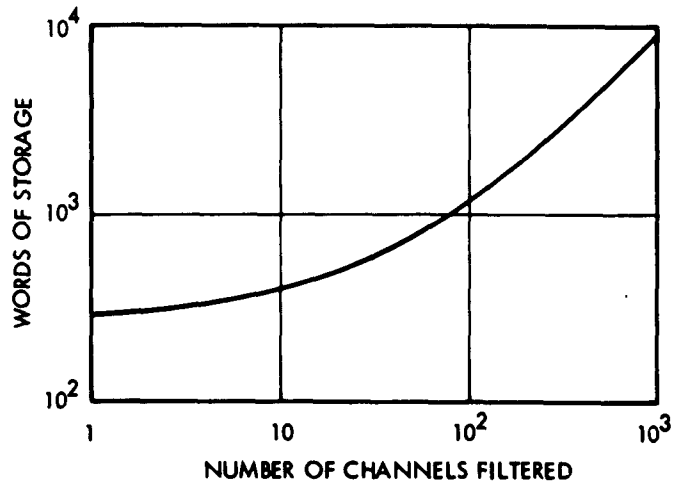

a. Recursive numerical filtering

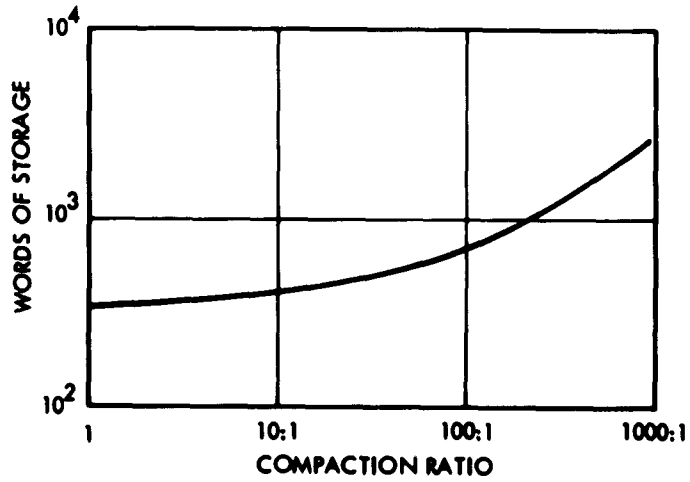

b. Pattern recognition

Figure 2. Typical Storage Requirements

The amount of computation required generally increases less rapidly with degree of compaction. Editing techniques, in particular, may be programmed to require a constant or decreasing number of computations per input point with increasing input to output ratios. However, data reduction, coding, and decoding require increasing computation capacity as the degree of compaction increases. Some typical relations are diagrammed in Figure 3.

Machine-dependent consideration affecting memory capacity are such factors as the instruction repertoire (the same problem can usually be programmed into less memory if the instruction repertoire is large and well adapted to data manipulation), and the control over and degree of simulation input-output functions. Memory access rates, the number of accesses required per instruction, and the number of instructions required for the average operation all directly affect the computational capacity needed.

Other cost factors that are often overlooked are the availability of suitable software for executive functions and efficient assemblers and computers.

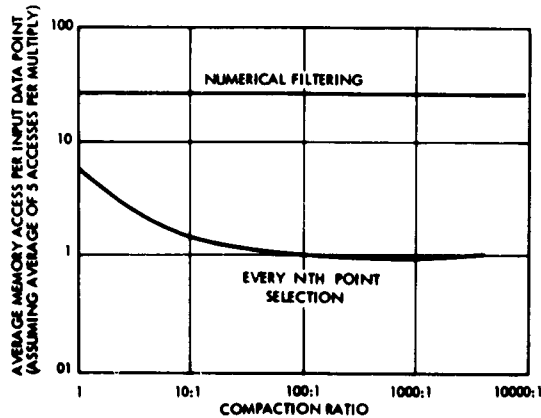

a. Editing

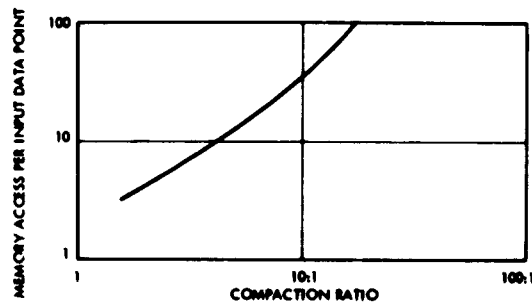

b. Minimum Redundancy Encoding for Typical Trajectory Data

Figure 3. Typical Computation Capacity Required

## Appendix XXX. ERROR CONTROL FOR DATA TRANSMISSION

### A. ERROR CONTROL AND RANGE COMMUNICATIONS

Error control is used in data transmission networks to provide assurance of data integrity at various receiving points. Two methods of control may be used.

The first method is the judicious selection of communication techniques and implementation. Examples of this selection are (1) media, (2) ranges and repeater spacing, (3) rates and bandwidths, (4) modulation and selection methods, (5) radiation parameters such as frequency, power, antennas, (6) synchronization and timing techniques, and (7) other link-design factors. As a matter of fact, the exerting of error control on a global range through selection of elements like these will be constrained by geographic limitations and cost. (For example, redesign or major modification of existing link facilities such as submarine cables, wideband intrarange links, common-carrier Conus\* nets, and scatter links cannot be economically justified. Thus, error control through communication design will have to be accomplished largely through network and interface mechanizations of existing facilities, and in the enhancement of terminal equipment used in existing links. Mechanizations possible include circuit redundancy, backup sources, rerouting plans, and short-term augmentation with special circuits. Terminal equipment can be enhanced with superior modems, increased power, improved interference rejection, and improved antennas.

The second error-control method is the use of error-protection codes. The technique will receive increasing attention and will be used more as the design details of the global range communication and traffic-handling systems are formulated. Coding techniques will find principal range application at pretransmission and postdetection network points. Coding enhanced data transmission will be achieved (1) through improving link composition to decrease the probability of bit error at detection and (2) by using redundant coding techniques to decrease the probability of residual message errors. (In deep-space links, which have very low S/N ratios, approach (1) above is less appropriate. Instead, highly

---

\* Continental United States

redundant coding can be used to improve the accuracy with which information digits are detected, e. g. , representation of individual information bits by code words from orthogonal or biorthogonal sets and use of maximum-likelihood detection. )

Error-control coding for digital data transmission involves imposing message constraints by augmenting the original data with controlled redundancy. Error detection (and sometimes correction) is then achieved by recognizing deviations from these constraints which appear in received messages due to errors incurred during transmission. The coding constraints may define the error adequately to permit correction, or correction may be effected by retransmission of messages detected as erroneous.

The amount and nature of error control which will be employed for particular range links (or composite circuits) will be based upon several determinations:

The intrinsic (uncontrolled) error rate of the link. This will depend upon the communication mode (ionospheric reflection, ionospheric scatter, tropospheric scatter, line-of-sight microwave, etc.) and upon the individual mechanization (power, modulation technique, path and terrain, noise and interference, etc.)

The error tolerance of the link traffic. This tolerance (acceptable residual error) will depend upon the nature of the data (source, format), its internal redundancy or other protection, and the use which is to be made of the message.

Limitations upon control employment. These limitations will arise from implementation considerations (cost, complexity, state of the art), link constraints (requisite rate versus available bandwidth, predictability of link anomalies, etc.) and message requirements (intolerance to delay, unavailability for repetition, format requirements), network requirements (interfaces, buffering, handling, routing).

Making the listed determinations, particularly the assessment of the tolerances of various data types to error and delay, will represent a significant task in the system design.

**B. SOME ERROR-CONTROL CODES AND SYSTEMS****1. ERROR-DETECTION(ED) AND ERROR-CORRECTION (EC) CODES**

It has been mentioned that error-control codes impose message constraints by adding controlled redundancy to the original information. A simple example is the use of a single parity bit. Adding an extra bit to an  $n$ -bit character, and choosing the value of the bit added to make the number of "ones" (for example) an even number constrains the message of  $n + 1$  bits to have an even number of ones. Any subsequent alteration of the character which results in changes of value for an odd number of the  $(n + 1)$  bits destroys this parity, and is detectable. If bit errors within an  $n$ -bit character are independent ("random") and of low probability, then the probability of a large even number of errors becomes quite small and the single error case, for which detection is guaranteed, becomes preponderantly likely. If not, then parity bits can be assigned to subcharacter groups of bits, as well as to the total character (as in "Hamming codes"), to provide additional protection. Since these redundant check bits must be transmitted along with the original data bits, the percentage of transmission which represents data transfer decreases. The proper use of an adequate number of check bits may sufficiently isolate error bits to permit their correction at the receiver. Also, if errors are known to tend toward predictable patterns, such as "clusters" or "burst," then check bits can be assigned so as to maximize the detection of these error patterns. Modern coding theory has provided many codes (that is, rules for deriving the values of check bits) which permit both easy implementation and error protection which can be tailored to the error characteristics encountered on particular links. For example, the cyclic codes of Bose and Chaudhuri ("B-C codes") can be nicely employed to detect burst errors such as those encountered on impulse noise-perturbed telephone circuits. Also W. W. Peterson and others have shown that suitable encoders and decoders may be conveniently mechanized by linear feedback shift-register techniques. Many other coding structures have been developed which emphasize the detection or correction of likely error-bit configurations, or both. Codes which permit direct correction, however, require increased redundancy and are generally more costly to implement.

Another common coding approach is to generate the data directly in a redundant format, rather than subsequently augmenting it. Constant Ratio Codes, for example, represent each alphanumeric data symbol by a bit array containing a fixed ratio of "ones" to "zeros". (The common Moore 4-out-of-7-code represents each symbol by a 7-bit character containing four "ones" and three "zeroes".) Received characters not conforming to this constraint are thus recognized as erroneous.

An even simpler approach to error detection is simply to transmit the message several times and perform a comparison or "voting" (majority decision) at the receiver; this approach is, of course, highly redundant.

## 2. CONTROL SYSTEMS

If the selected coding does not permit direct correction at the receiver, the receiver must either discard erroneous messages and go on, or request retransmission. These choices give rise to several error-control-system mechanizations. With forward-acting EC codes, the link may be simplex. That is, the receiver is able to perform adequate error correction, and hence requires no return communication link (feedback) to the transmitter for purposes of verification or repeat requests. Alternatively, the receiver may have only detection capability, and must then either discard data detected as erroneous and proceed, or request retransmission of data determined as erroneous (decision feedback). Another possibility (similar to multiple-transmission with majority-decision in its redundancy) is for the receiver to make no decision, but to merely feedback a description of the received message which is adequate to permit the transmitter to detect an erroneous transmission ("information feedback").

The total system mechanization for error control on a link or composite circuit may apply any of the preceding (or other) approaches to error detection or correction, or both. One approach which is popular for handling HF teletype traffic is the ARQ system. Here, information flows in both directions between two terminals (full duplex) and character-errors are detected by using the Moore 4-out-of-7 code (for example). Verifications of correctly received data or requests for repetition of

erroneous data (RQ) are returned to a transmitter along with the forward data destined for that terminal. Buffers at each terminal retain transmitted data long enough to permit the transmitter to "go-back" if repetition is necessary.

An extension of this mechanization is the "go-back-q" system of Lincoln Laboratories. Here, error coding applies B-C codes to blocks of data, and transmission is via telephone circuits with high-speed data modems. Synchronous transmission is maintained in both directions, and terminal buffers permit a transmitter to go-back "q" blocks in order to retransmit an incorrectly received block.

### C. GLOBAL RANGE REQUIREMENTS AND PROBLEM AREAS

For this discussion, global range data transmission may be considered to comprise three principal exchanges:

- Transmission between Range Control Centers and associated downrange instrumentation stations. This traffic consists mainly of:

Metric and telemetric data acquired at IS and passed on to LRCC (or GRCC)

Data control programs, tracking data, and command and control data distributed to the IS.

Miscellaneous administrative traffic.

- Transmission between IFCS and MCC.  
The accuracy-critical data here is mainly mission-oriented acquired data having real-time urgency, specific requests for such data, and mission command and control data.
- Transmission among the LRCC, GRCC, MCC stations, and other terminals having total-network interest. This traffic would include status and metric information pertinent to range safety, abort, recovery, and other critical mission phases, as well as data distributed for national surveillance, defense, and general informative purposes.

The second and third categories present many possibilities and requirements for imaginative communication network design. Error control should be relatively straightforward, however. The location of terminals within the continental United States should permit their interconnection by high-quality circuits, and ample circuit redundancy should be available to provide multiple routes (either simultaneous or as back-up). Basic network design will focus on traffic volume and routing requirements, format conversions, buffering, and interfaces. Constraints imposed by the resulting configuration (circuit types, processing capacity, storage) and by consideration of error and delay tolerances should then suggest a preferable error control mechanization. An open-loop procedure involving block coding and some correction capability would seem most appropriate for sensitive data (such as selected-status telemetry or metric data involving a manned vehicle in a critical phase). The circuit delivering such data could be tenuous and complex and could preclude adequate response with closed-loop techniques. Combinations of burst, error-sensitive codes, and proper distribution of information digits within coding blocks can be used to emphasize protection against nonrandom error distributions for circuits so inclined. It should be practical to afford these sensitive data added protection by employing considerable redundancy in both message coding and transmission circuits, since their volume and duration would be relatively low.

Other traffic in this portion of the network can receive relaxed but compatible protection. For example, basic message formats can employ blocks tailored to less sensitive data, with some portions used for additional check bits when warranted.

Data characterized by very high error sensitivity but fair delay tolerance (e. g. , computer programs) can be handled by closed-loop techniques, including 100-percent information feedback (i. e. , return received message to transmitter for comparison).

The first transmission category noted above, that of intrarange communication, represents a more demanding error-control requirement. Although some links within this network area can be expected to have normal bit error rates between  $1/10^4$  and  $1/10^6$ , mostly those composed of microwave line-of-sight, submarine cable, some scatter links, and land-lines

employing superior modems, coding for general use on such links can be designed to detect the infrequent periods of abnormality or circuit dropout, as well as the occasional bit error, and need not be highly redundant (e. g. , 5 to 10 percent of transmission capacity). The additional protection required for exceptional messages can be message-oriented, so as to not represent a continual transmission rate penalty.

Some of the intrarange circuits, however, will be less reliable. Not only may HF (ionospheric reflection) links have error rates of  $1/10^3$  or worse, but they and others may be expected to suffer periods of severe noise, fading, or dropout which virtually preclude transmission. Severe auroral activity may make HF communication impossible for several days in some areas. Redundant message coding cannot cope with these catastrophic anomalies, and backup via some other medium is the alternative to waiting. Where geographical and economic considerations do not permit backup or replacement of HF links with scatter or cable links, error rate may be reduced by a combination of modulation and coding techniques. Use of FSK or PSK with frequency-skipping (e. g. , QFM, QPM) provides some protection against multipath on HF, and error coding permits additional control.

## Appendix XXXI. RANGE-ORIENTED PROGRAMMING LANGUAGES

This appendix summarizes the problem of programming range computers and investigates a number of existing computer languages. An analysis of the problem is presented and preliminary steps toward a solution are outlined.

The programming languages currently being used for range application are most often the symbolic representation of the machine language of a specific computer. Consequently, given the same complement of equipment at any of the computing centers, but given two different computers, the programming task is doubled. An area of possible savings involves standardization of the problem specification language. Specification language is defined to be a definition language one step removed from the writing of the computer program. The specification language may or may not be translatable on a computer, as a compiler language such as FORTRAN is directly translatable on a computer. If the specification language is directly translatable on a computer, it may be translated on a computer other than the computer on which the problem is to be executed.

An attempt was made to utilize programming languages in existence today which seem to have universal appeal. The languages chosen were: ALGOL-60, FORTRAN, IPL-V, JOVIAL and NELIAC. COBOL was not included in the study because it is a problem-oriented language which is a subset of English for expressing the solution of business data processing problems.

ALGOL-60 was designed as a language for expressing processes of scientific and engineering calculations and of numerical analysis. ALGOL-60 has become the publication language of algorithms. ALGOL translators exist for a variety of large computers (e. g. , IBM 709, 7090, UNIVAC 1107).

FORTRAN, developed by IBM, is intended to be capable of expressing any problem of numerical computation. For problems in which machine words have a logical rather than a numerical meaning, it is less

satisfactory, but this lack may be rectified by using machine language subroutines. Versions of FORTRAN have been implemented on computers of all sizes and makes. Most computers today have FORTRAN as part of their software libraries.

IPL-V (Information Processing Language-V) was developed by RAND Corp. for list processing and symbol manipulation. It was designed to solve two technical problems: dynamic memory allocation, and extremely free operation of routines, including the ability to define routines recursively. Translators exist for the IBM-650; Control Data G-20, 1604; IBM 704/709/7090; and other large-scale computers.

JOVIAL was designed and implemented by SDC to produce programs for large, computer-based, military command and control systems. It is currently available on such commercial computers as the IBM 7090, Philco 2000, and CDC 1604, but in each case it has a slightly different form.

NELIAC was devised for real-time control problems, but is sufficiently basic for mathematical use. Like ALGOL, of which it is a dialect, it assumes that input-output is fundamentally machine-dependent and cannot be considered as an integral part of the language. NELIAC has been implemented on many computers: Burroughs 220, IBM 704/709/7090, CDC 1604, CDC 160A, and PB 250.

All the languages studied, although they were currently widely used in selected applications with some degree of success, were found deficient for one or more of the following reasons:

- o Compiled programs made inefficient use of storage and/or time.
- o Input and output were not designed to take maximum advantage of all computing time available.
- o Two compilers of the same name being implemented on different computers were not always compatible in completeness of language or in the manner in which statements were written.

- o No provision was made for insertion of machine codes.
- o Formatting of input and output was not as efficient as it could be.
- o The full range of functions allowable by a digital computer was not used (e. g. , ALGOL allows recursive functions whereas some other compilers do not).
- o Dynamic memory allocation which would permit two programs compiled independently to be executed at the same time is not available with most compilers.
- o Compilers are generally deficient with regard to real-time applications (e. g. , timing considerations).

A study was also made of the Information Algebra. The Language Structure Group of the Development Committee of Codasyl was formed to study the structure of programming languages for data processing problems and to make recommendations which would guide the development of future programming languages. This seemed an appropriate language to study since the problem of the global mission can be categorized as a complicated command system superimposed on a massive data processing system.

Limitations of current programming languages include machine-dependency to varying degrees, the requirement of ordered procedure statements, and segmentation into discrete execution phases. Existing programming languages are essentially procedural in nature, but these are examples in which relationships rather than procedures are specified. The Information Algebra attempts to extend the concept of stating relationships among data to all aspects of data processing. The inherent properties of a procedural language make it difficult to specify computer processes independently of the computer on which they are carried out. As a simple example, consider the evaluation of the expression

$$y = ax + b$$

On a one-address computer the machine language procedure for this process might be expressed as follows:

CLA X	ADD B
MPY A	STO Y

On a three-address computer, the procedure would be quite different:

```
MPY A/X/TEMP
ADD TEMP/B/Y
```

Clearly, the procedure for the process is strongly machine-dependent.

More sophisticated languages, like ALGOL and FORTRAN, overcome problems of the type illustrated above by admitting nonprocedural specification of certain arithmetic processes. In FORTRAN, the process is expressed simply as

$$y = A * X + B$$

Such statements imply an ordering of the operations to be carried out (i. e., that dictated by the rules of algebra), but are properly classed as nonprocedural since the procedure for carrying out the required operations is not explicitly stated.

By means of such nonprocedural specifications, large parts of a computer process can be specified in a nonprocedural way in a language like FORTRAN if one is willing to construct sufficiently long and complex expressions. However, most computer processes also require operations which cannot be expressed nonprocedurally in a language like FORTRAN. The main culprits are conditional operations, i. e., operations which are dependent upon values of input data, and input/output operations.

With such problems in mind, workers in data processing have been giving increased attention to entirely nonprocedural programming languages. A nonprocedural programming language may be defined as one in which a computer process is expressed solely in terms of the results of the process, rather than in terms of the procedure by which the results are to be produced. In engineering terms, the nonprocedural language allows the programmer to define the final state of the computer as a function of its various possible initial states.

Since machine languages will remain largely procedural, at least in the near future, a nonprocedural language implies the need for a mechanism for transforming a nonprocedural specification into a machine language program. Such a mechanism will be similar in function to current compilers but, because of the essential difference between its

input and that of current compilers, might be better termed a procedure writer. The essential feature of the procedure writer is that the production of a step-by-step procedure is taken completely out of the hands of the programmer. As a consequence, the procedure-writer is free to develop procedures most appropriate to the computer which will execute them.

The philosophy of a nonprocedural language as a specification language has much merit for the problem at hand. The only additional information needed is the computer specifications. This is a very big "only" since we do not now know how to specify a computer to a computer for the generation of computer programs from nonprocedural statements. The ideal system is illustrated in Figure 1.

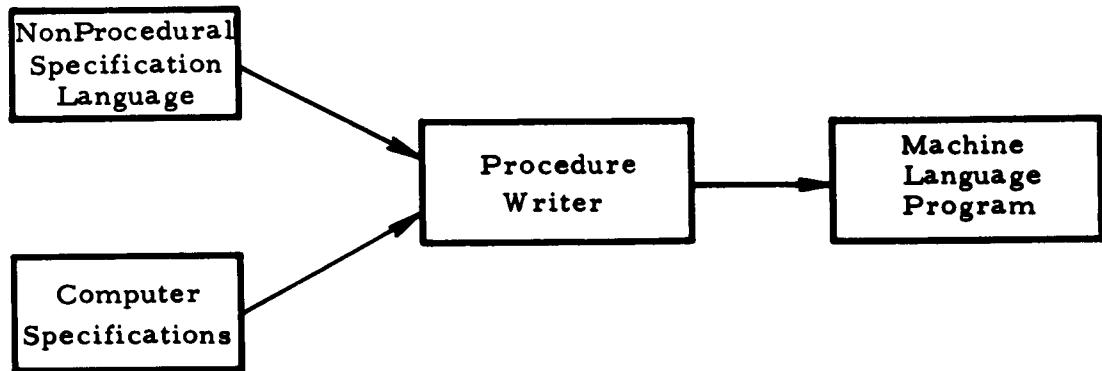

Figure 1. Ideal System for Generation of Computer Programs

The ideal system for generating computer programs may be rediagrammed to show current status (Figure 2).

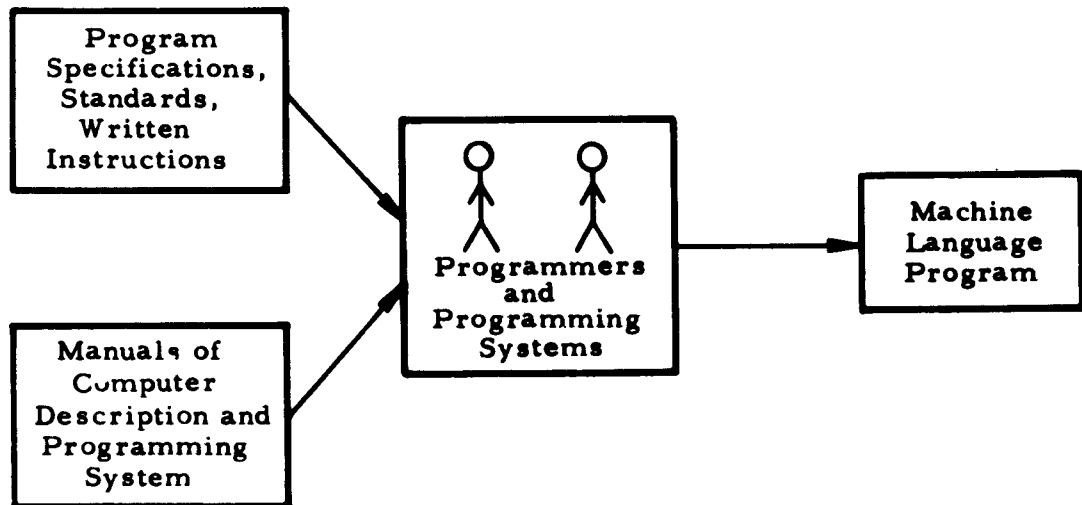

Figure 2. Current System for Generating Computer Programs

As can be seen from the diagrams, if a variety of types of computers are to be used to execute the same problem today, the area to which attention should be directed is problem specification. If statements of relationships can be made, in some formalized way, of the results required of each computational or data-handling phase of the global range operation, then some progress will have been made toward attaining the ideal system.

However, the making of unambiguous statements in the computer field today is almost impossible, because no accepted standard glossary of the meanings of terms exists (Reference 2). In the light of this fact, the Information Algebra could be a solution to problem definition since it uses a mathematical approach to problem solution by relating the inputs and results of each phase in a rigorous manner and does not indicate the computer procedure by which the result is to be accomplished.

At TRW Computer Division of Thompson Ramo Wooldridge, Inc., corporate-sponsored research to explore techniques for machine-independent software is underway. The purpose of the research is to do away with the need to repeat the development of software for each new computer developed. A paper will be presented at the 1963 Fall Joint Computer Conference, entitled "An Experiment in Nonprocedural Languages" by Jesse H. Katz and William C. McGee. This paper gives an application of the Information Algebra to an assembly program (Reference 3). Other investigations have shown that mathematical problems, such as matrix multiplication may also be stated in the Algebra.

The Information Algebra is one answer to nonprocedural problem statement. However, something more conventional may be the proper immediate approach, while research in nonprocedural language is being continued. One of the first items to be looked at is data or file definition. What are the properties required to completely define the information to be processed?

As an illustrative example, some of the properties associated with the information in a stream of telemetry data are listed below.

- Name of variable
- Location and number of bits of variable in data stream
- Organization of data
- Units of measurement
- Typical error in data received
- Redundancy bits for error checking
- Expected range of values
- Expected maximum rate of change
- Frequency of sampling
- Other variables to be sampled at same time
- Where is variable to be forwarded
- Techniques for processing data
- Format of transmitted data

The formats for defining properties must be worked out. The problem of range documentation requirements has been under study for some time and every attempt should be made to assist in formulating standards for processing requests and to adhere to standards already set.

The language of program description and program requests also needs some attention. At some time, early in mission planning, a list of the various programs required by the user must be presented by the user to the range. Although the user will have a list of all the programs currently provided by the range, all programs desired should be indicated. The range would record requests which it cannot currently satisfy. However, when enough requests for a routine not supplied are received, the range will make every attempt to supply commonly used routines. In order that no misunderstandings occur, the program descriptions must be given in a clear, concise manner. Program requests must be clear and concise; information included should be (1) name of program, (2) range of values that will be processed, (3) degree of accuracy, (4) format of input data, and (5) format of result or output data. The formal method of requesting and describing programs is one of the communication language problems of range documentation. Again, every attempt

should be made to adhere to standards already set and to give assistance in setting additional standards.

The programming communication language for problem solution is not the only language problem to be considered. There is also man-machine communication. The form in which instructions should be sent to the Instrumentation Stations and the responses to these instructions which must be sent back to the Local Range Control Centers must be standardized.

How does an operator indicate to the Local Range Control Center that a device is not available? How does an operator indicate that he has performed a readiness check? How does an operator indicate what stages of readiness check have been completed? If by voice only, an automated system becomes man-limited (e. g. , when misunderstandings occur). This area of communication needs much attention. Above all, this type of language must be "natural" to the people using it.

A range-oriented language which will define the physical system to programmers, users, and operating personnel in the form needed to understand the systems program would be helpful. It should be noted that this is not synonymous with equipment manuals where detail is too minute for the uninitiated.

An indication of the total programming problem that faces us has been recorded here. The solutions can be realistic and effective if a step-by-step approach is used to achieve the final goal. The first unexpected observation made during the study is that none of the languages which are so-called "command and control" languages have been effective. This probably has been the result of attacking the total problem rather than perfecting the individual parts of the problem first.

A recommended approach to the solution calls first and foremost for standardization--standardization of terminology. A glossary of the meanings of words in computer science and a glossary of the meanings of words in the space effort are needed. Wherever possible, interrelations between the two disciplines should be indicated. With

a glossary in existence the total problem can be defined in terms understandable to all .

While every attempt is being made to achieve standardization, the total programming effort must continue with the development of efficient hand-code routines which, if frequently used, could become the macro-instructions of an interpretive system. As various routines are programmed, an attempt would be made to standardize as many portions as possible so as to reduce the total programming effort. Common elements in various acquisition, coordinate transformation, telemetry data reduction, etc. , programs would be studied and developed for multiple-mission use.

Nevertheless, while work is proceeding on the programming for missions which are near in time, work must also be gotten underway on some formalized approach to the specification of each phase of the total problem. The Information Algebra, as indicated earlier, is a possible candidate for this formal language, but its development is still in its infancy. In an attempt to eliminate the reprogramming of one problem for each different type of computer on which it is to be executed, techniques of specifying computers to programming systems (e. g. , compilers) along with problem specification could produce machine language programs for a variety of computers for the same set of specifications .

Each facet of the problem examined eventually comes up against the hard wall of lack of standardization which leads to lack of the ability to properly specify the task to be accomplished. An effective solution to the programming problem will be achieved only when the necessary standards are set and adhered to.

## REFERENCES

1. "An Information Algebra Phase I Report," Communications of the ACM, Language Structure Group of the Codashyle Development Committee.
2. J. P. Haverty and R. L. Patrick, "Programming Languages and Standardization in Command and Control," The RAND Corporation, Santa Monica, California, January 1963.
3. J. H. Katz and W. C. McGee, "An Experiment in Nonprocedural Languages," Joliet Computer Conference, Fall 1963.

## APPENDIX XXXII. DATA DISPLAY

### A. INTRODUCTION

The present display technology and future projections may be viewed from a number of vantage points. The approach taken here is to examine the broad aspects of display objectives and design considerations (Section B), and the techniques applicable to implementation of devices and systems (Section C).

A large number of reports and papers, some unpublished, have been consulted in the preparation of this document. No effort has been made to provide comprehensive coverage of the display technology in the 1965-1970 time era for two reasons.

A number of surveys have been reported and are readily available (see References 1 through 6).

Reliable information regarding progress in new developments is generally unavailable to contractors. Up-to-date information is presumably available to qualified Government agencies in a document which is believed to be undergoing revision at the present time (Reference 7).

## B. DISPLAY/CONTROL CONSIDERATIONS

The subject of this section is the man-machine interface which has been designated as Display/Control. In a narrow sense, display refers to the means for visually presenting information to people in the system. Control refers to the means whereby system personnel choose or modify the information to be presented, and enter data, decisions, and commands into the system. The discussion includes display objectives, aspects of data presentation, information quantities and rates, and a qualitative comparison of group and individual displays. Some of the system design factors directly influenced by displays are briefly considered. Finally, techniques for the transfer of human decisions to the machine are treated briefly.

### 1. DISPLAY OBJECTIVES

Lack of a single all-inclusive objective forces consideration of many display objectives and criteria. Some of the more appropriate ones for displays are described below.

#### a. Improvement of Understanding

The quality of decision making is based on insight and understanding of the problem. Thus, the display system should allow the user to assimilate, perceive, and comprehend the information available from the balance of the system. The display system should also take the initiative in notifying users of emergencies, exceptions, and urgent information.

Complex situations must be presented in such a manner that significant relationships, conflicts, correlations, and extrapolations can be quickly, clearly, and correctly comprehended. Separate categories of information should be displayed in a manner that optimizes the user's ability to detect these relationships. Displays should allow details to be understood in context with the whole situation and should allow the whole situation to be examined in detail.

Any display system involving data storage and retrieval has a classification and indexing problem. Users must be able to quickly and conveniently identify and request various data categories or combinations

of information characteristics. It is often desirable to request displays by logical statements regarding relationships between classification parameters and data characteristics.

A display system should augment data entry capabilities by providing supporting information and aiding data entry by displaying indexes, formats, and data being entered.

The effectiveness of a display depends on the user's perception, which has definite psychological limits. Other considerations, such as individual display preferences, also warrant evaluation.

The system should allow the users to extend their decision making capabilities by use of the memory and processing capabilities of the balance of the system. An ultimate objective might be that of providing a man-machine communication link which approaches telepathic capability.

b. Improve Control

Improved coordination within diverse operations is an objective of display systems. When each user or group has different data from different sources, contradictions and misunderstandings may arise. Each group should have current, identical data available. Even within a given display, different data should have consistent "as of" times to reduce confusion.

Simplicity of operation is an important objective. If equipment is difficult to operate, it will not be used effectively. Training requirements should be minimized. Maximum interchangeability of operations and functions should be provided.

c. Provide Flexibility

Flexibility is an exceptionally important criterion of display systems. Flexibility may be expensive either if it is not provided or if it is provided. If a system cannot adapt to changing requirements, it loses operational value and may have to be replaced early. If a system incorporates excess capability to meet any unforeseen requirements, its initial expense may be unwarranted. Flexibility should not be used as a replacement for good system analysis but a good system analysis should recognize that

display requirements often change drastically with time. This occurs because of:

- Changes in top level decision makers
- Changes in supporting staff personnel
- Changes in organization and staff functions
- Changes in information available
- Experience from system operation and exercises
- Improvements and additions to computer programs
- Technological improvements
- Modifications in mission.

Thus, flexibility to adapt to necessary changes quickly and effectively is a primary objective of display systems.

Some of the aspects of display systems where flexibility is desired include:

- Formats
- Content
- Symbology and coding
- Display control and utilization
- Distribution of personnel
- Distribution of displays
- Growth potential in both quantity and performance.

Enormous flexibility can be provided by computer programming since new programs can be prepared as new requirements arise.

## 2. DATA PRESENTATION

There are many different ways of presenting information for visual interpretation. This discussion is confined to visible markings on a two-dimensional display surface.

### a. Coding and Symbology

Some means of coding information in visual form are listed below. The approximate range of distinct coding levels for independent recognition is also estimated. This, of course, varies considerably with specific situations, interpretations, and combinations of coding modes used. The estimates are a consolidation of the opinions of Dr. S. Smith

of MITRE, and Dr. G. Miller and R. T. Loewe of Aeronutronics. The total number of usable coding levels from combinations of these coding modalities depends on the specific application.

<u>Coding Modality</u>	<u>Coding Levels</u>
color	3-10
size	3
shape: alphanumeric and punctuation	50
abstract	8-16
suggestive	200-1000
position: linear	3-5
2 dimensional	4-9
3 dimensional	8-12
orientation	4-8
line width (boldness)	2-3
number (quantity)	4
flicker or blink rate	2-4
intensity (brightness or grey scale)	2-4
line length	2-4
line type (dotted, dashed, etc.)	3-4
focus or distortion	2
depth	2-3
motion	2-10

The above types of coding are generally applied in four basic presentation forms: alphanumeric, symbolic, line drawings, and area representations.

Alphanumeric. Data displays composed of alphanumeric characters in tabular or straight text form are the most common type of computer output for human interpretation.

Symbolic. Symbols of arbitrary shapes provide an efficient means of representing (coding) complex thoughts, objects, or events. The maximum number of different symbols is limited by the user's memory and the mnemonic value of the symbols. They provide a good medium for other coding modes such as color, size, orientation, blink rate, and intensity.

Line Drawings. Certain varieties of data cannot be presented alpha-numerically or symbolically in an effective form suitable for human comprehension. Examples of data that are best displayed in line drawing form are: isotherms, air lanes, roads, topographic contours, functions of a variable, vehicle courses, satellite tracks, radii of coverage, fallout contours, coverage of surveillance devices or weapons, planned maneuvers, and meteorological patterns. Line drawings are an effective means of presenting such information and are still compatible with computer outputs.

Area Representations. Displays of areas are occasionally necessary. Examples are: mine fields, fallout hazard areas, swamps, areas of responsibility, and areas on charts or graphs. Areas can generally be well represented by line drawings, symbol arrays, cross-hatching, and annotation. Colored or shaded areas are good representations for such information, but are less compatible with computer outputs.

Evaluation of coding depends upon a number of factors, such as the physiological limits of human discernment (e. g., the point at which the human sensor cannot reliably discriminate between two brightnesses or colors), relative compatibility with other coding modalities, relative efficiency of the code (how long does the average operator take to make a positive identification), and psychological effect on the operator (is the code irritating, fatiguing or perhaps hypnotic, as in the case of some flicker rates). These and other considerations must be examined prior to evaluation, selection, or use of a particular coding modality.

#### b. Display Formats

In system design, presentation formats must be selected after determining what information must be displayed. These decisions are as important to display system effectiveness as are many technical decisions. Coding and symbology capabilities must be considered in selecting formats.

Generally, formats must be selected which allow superposition of different types of information to clearly show interactions, relationships, and conflicts.

Many special formats have been contrived for specific purposes. Radar displays and fire control displays are good examples. The contact analog displays being developed in ANIP are special dynamic formats. They simulate the actual visual pattern the pilot would see if he were flying by visual contact rather than by instrument.

A wide variety of formats can be employed in displaying information. Typical of these are text, table, diagrams, graphs, line drawings, and bar charts.

### c. Maps and Reference Backgrounds

Maps and reference backgrounds are frequently used in display systems. They are generally of a relatively permanent nature which do not require rapid updating. However, they may require a rapid request response time. Although maps are the most common type of reference backgrounds, format headings, diagrams, and actual scenes are also used. Permanent formats, such as tabular row and column headings and lines, can reduce the amount of data storage and display generation to only the variable data. Block diagrams provide an effective background for control system displays. Windshield displays and other optical mixing methods allow actual scenes to be used as backgrounds for displays.

Map data content requirements may be determined in the same manner as other display requirements. It is highly desirable to handle map data categories in the same manner as other display categories. Then specific topographic data could be stored, updated, requested, and displayed in a much more flexible manner. Most available maps are drawn for general purpose use and do not generally match display system requirements very well. If a reasonable number of maps are involved, it may be wise to have special maps drawn to provide optimum displays. This allows content, symbology, coding, and coloring to be compatible with the display system.

Frequently, very simple outline maps are all that is required. Black and white line drawings are adequate for showing land masses, political (national and state) boundaries, principal cities, and geo-

graphic features. Such simple data can easily be handled in the same digital form as other display data.

Map scale changing and centering presents a problem in some systems. The problem is that of viewing the area of study on one map of the proper scale without running off the edge or using a scale on which the area of study is very small.

Several methods which can be used are:

- (1) Optical magnification
- (2) Selected set of map sheets of arbitrary scales covering locations of primary interest
- (3) Organized set of overlapping map sheets
- (4) Overlapping rolls of maps
- (5) Electronic scale changing
- (6) Identifying random center and scale
- (7) Identifying map boundaries.

In order to register data properly, coordinate conversions are generally necessary. Frequently, the display generation coordinate system is not the same as the map coordinate system. Location data are received in several different coordinate systems. Thus, coordinate conversions are necessary to generate displays with the proper relationship to the map backgrounds.

The generation of adequate coordinate conversion routines is a demanding task. Significant misregistration can occur if this is not performed carefully and accurately. One method which has been used successfully involves measuring a number of points on the map very accurately in both map and display coordinate systems. These sets of coordinates are then fed into a computer routine which generates coefficients for a generalized coordinate conversion routine.

### 3. INFORMATION QUANTITIES AND RATES

Three factors which influence the amount of information displayed are:

- (1) Rate of comprehension
- (2) Display access time
- (3) Visual perception.

a. Rate of Comprehension

The rate of comprehension is a major factor in determining how much information should be displayed. If a person must respond to information quickly, he does not have time to comprehend great detail. Thus, highly summarized information assists the making of rapid decisions. With enough time, however, a complex and detailed display can be absorbed or understood. Analysis, interpretation, evaluation, and detailed planning functions often require the thorough understanding which comes from extended study of detailed information.

There are several situations in which it makes sense to present more data than can be comprehended. One relates to the Gestalt or big picture concept. A commander may only glance at a display to gain an impression of the general degree or location of activity. Another reason is economics, where several persons derive different types of information from a common display. Perhaps the major reason for presenting more data is to provide simple, rapid access to information. However, presentation should not be carried to the point where it becomes confusing or delays accessing.

b. Display Access Time

When the information required by an individual to perform his functions exceeds the capacity of one display, access to other displays must be provided. Display access time is an important characteristic of display systems. This is defined as the time lapse between a user's request and the display of the requested information.

Two primary methods of access to different displays are:

- (1) A single display screen is provided, and the information displayed upon it is changed at the command of the user
- (2) All display information is simultaneously presented. The user gains access to different information by focusing his attention on the desired display. (A variation of this is the use of magnification to provide access to more detailed information in a display.)

Shifting the head and the eyes from one display to another is an extremely rapid and convenient means of gaining access to more information than can be presented in one display. Even within a single display, a user's attention is generally focused on a small portion of the total information. For instance, in reading this page, the reader focuses his attention on only a few words at a time. Thus, there is a sequential display access in reading text. The same is true for other display formats except that frequently there is no sequential scanning. The entire display is comprehended only after viewing the entire presentation through focusing attention on individual elements and on their overall relationships. Frequently viewers must physically move from one display to another to gain access to desired information. Consider procedures in using a large wall map display with details meant for reading at 18 inches, plus several colored overlays.

If information requirements can be predicted, the total amount which need be accessible can be minimized. However, the general case is that the information needed to support thought processes cannot be predicted, and a user must be able to rapidly request and access all available display information.

Multiple display presentation also involves information classification, indexing, and retrieval considerations. The user must associate a need for information with the display in which it appears. He may then access that display by searching, remembering its location, consulting an index, or composing the proper request.

c. Visual Perception

Visual perception limits the amount of information that can be displayed. Visual perception is not as severe a limitation as the rate of comprehension. The amount of information that can be perceived is certainly much greater than that which can be quickly comprehended or that can be completely absorbed as an integrated whole after extended study. However, visual perception does limit the amount that can be made available for quick access by shifting the attention.

Considering the resolving power of the eye and the total solid angle useful for display, tremendous amounts of information can be presented. Visual perception also involves such factors as rates of change of information, color discrimination, and blink rate.

Visual acuity or resolving power is the ability of the eye to perceive and discriminate precise sensory (visual) impressions. The human eye can, in normal room light, discriminate parallel black lines, separated by intervals equal to the line width, when the line separation subtends about 1.0 to 1.5 minutes of arc at the eye. Thus, the eye has an angular resolving power of 50 optical lines (100 TV lines) per degree. From a fixed position, a user can conveniently see a plane display which subtends 50 degrees at the eye. This allows the eye to make out 2500 optical lines of detail on such a display.

The solid angle about an individual and the resolution of the eye limit the total amount of information that can be displayed simultaneously to any one person. Of course, the complete solid angle around a person cannot be utilized for display purposes, but cockpits, for example, frequently use much of the total solid angle for displays and controls.

Exact resolving capabilities vary with contrast, brightness, "clutter," background "noise," (e. g., maps), nature of use (prolonged study or occasional reference), viewing angle, and environment. More information can be packed into a resolution element by using such parameters as: color, grey scale, or blink rate.

Since the amount of information that can be presented in a single display depends primarily on the solid angle subtended and the resolution of the eye, the distance of the display from the user is not significant. This contradicts the popular concept that one must have a big display to see the big picture. The average human in normal room illumination has a minimum focusing distance of four inches at an age of 20 years. This distance increases to 8.75 inches at age 40, and to 40 inches at age 63.

d. Updated Response Time

The time between the input (entry of new data into a display system) and the output (resulting data displayed or ready for display) is the update response time. In systems which display many classes of information, this time is a function of the priority given new data, the data-input rate, the processing of queues, and the response time of the display equipment itself. Requirements vary from seconds to hours.

e. Request Response Time

The request response time is defined as: the time duration from request until the display appears. This is a function of the display data access means as well as the display generation process. It is important from an operational and psychological point of view that a display be created soon after requested. A request might designate, for instance, moving objects in excess of 30 mph, and their position. If displays cannot be changed or composed quickly and conveniently, it is likely that an expensive data processing system may not be used to its full potential. It has been stated that for a request response time of 3 seconds, users will forget what they asked for 50 percent of the time.

f. Display Generation Response Times

Display generation response time is the time from initiation of computer output until the complete display can be viewed. It does not include data entry, processing, and file access times as do the above times. It is one of the most important features when specifications or implementations are selected.

In determining display requirements or specification requirements for each of the above response times should be considered separately. The subtle differences in meaning may lead to significant differences in implementation.

A strong argument can be made that response time is the only justification for automating a display system. With adequate time, all other requirements could be met by manually generated displays. Possible exceptions to this are the error rate and the traffic handling rate.

#### 4. COMPARATIVE ADVANTAGES OF GROUP AND INDIVIDUAL DISPLAYS

The value of group displays versus individual console displays is a controversial topic. A group display is a display intended for simultaneous viewing by more than one person. This definition is independent of display size, although common use tends to link large screen with group displays. Individual displays are intended to be viewed by only one person. A list of advantages of group and individual displays follows. The points have been collected from many sources. Evaluation of each point for a specific system is left to the reader.

##### Advantages of Group Displays

- Where information requirements of a number of people are similar or identical, a group display may be more economical
- A working group can coordinate efforts and communicate more effectively, avoiding a feeling of isolation
- Many users are accustomed to working with manual group displays
- Manual backup procedures are more effective for group displays than for individual displays
- Less total equipment is required. This enables less maintenance and power, and fewer spares and computer output channels, etc.
- Provides more effective briefings
- There may not be enough physical space for many individual displays
- Support personnel can anticipate the concerns and requirements of senior personnel controlling the display
- Redundant sensing of displayed data provides operational reliability

### Advantages of Individual Displays

- Information may be displayed which exactly fits the task requirements of an individual, rather than a composite display not optimized for anyone
- Displays can be changed at will, gaining access to more information without interrupting others
- More useful in data entry, pointing, annotation, and planning; more effective man-machine link
- More diverse performance capabilities are available with the current state-of-the-art
- Redundancy of units provides greater reliability for critical functions
- The deployment of personnel and equipment has more flexibility than group displays
- It is possible to display identical data on all individual displays. This approaches the capability of the group display for allowing many people to simultaneously refer to the identical display information
- More information can be presented on individual displays than on group displays because the individual can lean over or bend over portions of an individual display to get the detail

### 5. MAN-TO-MACHINE COMMUNICATIONS

Most display systems are subsystems of larger data processing systems which divide the data-processing and decision-making activities between man and machine. Information must be communicated from machines to men in a manner that permits effective human perception and comprehension. Displays provide this capability. Similarly, information must be communicated from men to machines, preferably in a convenient, efficient manner.

a. Data Entry

Proper coordination of displays with data entry can greatly improve man-machine communication capabilities. Examples of inter-relationships of data entry and display are:

- (1) Processing requirements are minimized if data is entered in formats and categories similar to display formats and categories
- (2) Displays aid in evaluating and screening input data
- (3) Displays aid in formatting input data
- (4) Some units combine data entry and display functions
- (5) Entry of line drawing data is most conveniently performed with respect to a display background
- (6) Pointing to items on displays is a very convenient data entry feature.

In many cases the reason for displaying information is to obtain interpretations of human judgment or decisions. The results of these decisions must be re-entered into the processor for filing, further processing, and display updating. Often, the decisions relate directly to the displays such as (a) the drawing of lines or arrows to represent plans, (b) the identification of symbols or points as objectives, (c) or the entry of display requests.

Representative types of data which must be entered by men are:

Raw data  
Instructions  
Parameters  
Display requests  
Interpretations  
Decisions  
Comments and annotations  
Identification

Some of the functions men must perform in data entry operations include:

Composing  
Formatting  
Editing  
Abstracting  
Verifying  
Correcting  
Interrogating  
Intervening

Data may be entered in either alphanumeric or graphic form, or in both.

Some of the methods of manual data entry which can be coordinated with displays are listed below. Combinations of these are used in some units.

b. Typewriters and Logic Keyboards

Electronic typewriters generally consist of a CRT display, a typewriter keyboard, digital storage, and digital logic. Formats can be displayed either as blanks to be filled in or as headings below which data are entered. A cursor whose position can be manually and automatically controlled indicates where the next keystroke will be entered. The computer can also display data on the CRT. Electronic typewriters provide speed and accuracy in functions such as: composing, formatting, editing, abstracting, verifying, and correcting. The computer can display questions, answers, alternative formats, and checklists, and the user can enter decisions, requests, and instructions.

Logic keyboards consist of a set of switches or pushbuttons whose functions correspond with a logical operational sequence. The pushbutton descriptors may be changeable to correspond with several different applications or modes of operation. The pushbuttons may represent program branch points, operator evaluation of display data, display requests, commands, etc. The computer may be able to light separate pushbuttons to indicate the next step, the allowable choices,

instructions to the operator, etc. The analyst who defines the operations, procedures, keyboard designators, and program designators can use these in-out capabilities with great versatility (see Reference 8). Dr. B. Wolin of SDC has described a modification of this approach to the American University Institute on Electronic Display Systems, May 21-25, 1962. The modification uses a conventional CRT display to present the function descriptors. A light gun is then used to indicate the operator's selection. Instead of pushing a button, the operator points at a light spot next to the displayed descriptor.

c. Pointing Techniques

Several operations in which pointing is very useful in display system are:

- Pointing may be used for inquiry. This is accomplished by pointing to a symbol on a situation display for which more detailed data are desired, perhaps on an auxiliary tabular display
- Pointing may be used to identify items in lieu of entering an alphanumeric description of the item. The computer looks up the identity of the item by coordinates obtained in the pointing action. It is used in "hooking" targets in radar systems to initiate rate aided or automatic tracking
- Pointing may be used to select alternatives as described under logic keyboards above
- Pointing may be used to enter location coordinates in lieu of reading and entering coordinates in alphanumeric form. This is useful in manual tracking operations and in entering line drawing information as a sequence of points through which a line is to be drawn
- Pointing may be used to attract attention to a given item, area, or direction if a visible mark

is controlled by the pointing operation. This can be used in briefings. A remote pointer can serve as a visual intercom between displays and personnel in separated areas

- Pointing may be used in conjunction with a typewriter keyboard for data entry and in correcting and editing displayed information. A pointer mark can be positioned to indicate the position where an annotation is to be entered or where a correction is to be made.

Several methods of implementing the pointing operation are:

- Pointing may employ a light gun. This technique can only be used with marks that are already displayed on a CRT. Identification is formed by detecting time coincidence between data being displayed and the pickup of a light sensitive device in the light gun
- A stick or ball control knob can be used to manually control the X and Y positions of a visible pointer mark or cursor
- Pushbuttons may be used to move a cursor fast and slow, up and down, or left and right
- A physical stylus whose coordinates are automatically read may be positioned like a pencil.

#### d. Display Requests

To change the information categories presented on a display screen, the user must indicate the information he wants displayed (unless the system itself determines what data is to be displayed on the basis of previous analysis). A number of different ways of requesting displays are:

- (1) A keyboard with a separate button for each category to be displayed or removed can be used. This approach is made more flexible by using a single keyboard and changing the meaning of the keys as described under logic keyboards above
- (2) Where there are many categories, they may be selected by an alphanumeric code and keyboard. For example, when decimal numbers are used to indicate display categories, 100 different displays can be identified by two activations of a decimal keyboard
- (3) Displays can be requested by a limited syntax language or by logical statements. In this manner, a user can define the information combinations and formats he desires
- (4) Another method of defining information to be displayed is by pointing at an item on an existing display, or to a descriptor or set of descriptors
- (5) Searching is another method of obtaining the desired display. The actual display may be sequentially changed with the operator deciding when to stop the sequence of changes.

### C. DISPLAY TECHNIQUES

There have been many diverse research and development programs ; within the past five years directed to solving the problem of effectively presenting digital computer output data. The computer can perform high-speed operations of a very complex nature that are not meaningful to a human observer. However, the final result of the computer data processing must, in many cases, be matched to the physiological, emotional, and intellectual capabilities of the human decision maker. This is particularly true of the command and control environment associated with most of the present and planned military and space systems control center operations. Although an initial consideration of the display problem may indicate simple solutions, a detailed examination of the requirements demonstrates the high order of complexity associated with the various parameters. As a single example, the problem of providing a high-quality updated map in full color in quasi-real time (within one second from the initiation of the request) on a large viewing screen with adequate resolution, brightness, and accuracy is beyond the present state of the art. Modern display systems may necessitate utilizing most or all of the following technologies: cathode-ray tube design, transistor circuits, mechanical and electromechanics, optical design in the visible, infrared, and ultraviolet regions, dry and wet film exposure and processing, heat flow, digital interface, human factors, fluid dynamics, and solid state physics.

The present status of the display field may be compared to that of computer systems about ten years ago. At that time the computers in use, or in the early stages of design, had not been standardized in their techniques or performance. Relays, vacuum tubes, storage tubes, audio delay lines, and other elements now almost completely obsolescent characterized basic designs which differed widely from manufacturer to manufacturer. A similar situation exists today in the display field in that many different techniques are in use or are in the process of development, most of which have the same system objectives. It is predicted that only a few techniques will emerge within the next five years as superior and provide the basis for the display systems of the future.

At present, in general, consoles are dependent upon cathode-ray tube techniques and group displays upon projection optics. A system may, however, require the use of both; the console serves as an individual input-output device to instruct or request operations on the part of the computer, the large display to provide the results of these or other requests or programs to the group audience.

The discussion on each type of display will center on three major areas:

- A review of the major techniques now available for systems
- A detailed discussion of a particular implementation of a display system
- A preview of certain interim and advanced techniques planned for future systems.

It is useful to separate the discussion of display devices into two major categories: Section 1. below discusses group displays and Section 2 discusses individual console displays.

## 1. GROUP DISPLAYS

### a. Technique and Display System Review

The significant techniques that have been used or are available for computer driven group display systems can be placed into the following categories:

- Film generation and projection systems
- Electromechanically driven systems
- Projection CRT systems
- Schlieren projection systems
- Electrostatic systems
- Photochromic systems.

A general description of the basic principle of operation and the characteristics of each technique in relation to display functions and user requirements is provided. It is only possible within the scope of these notes to treat these concepts in a general manner.

## 1. Film Generation and Projection Systems

The most common method for creating an image suitable for large screen projection is storage on film. Rapid film recordings may be conveniently classified as wet or dry. Wet processing refers to conventional silver halide photographic techniques. With special handling procedures, rapid response for black and white film has been achieved for computer readout purposes within 20 seconds. Color film processing systems, although they have been speeded up to about a 10-minute response, are completely inadequate to meet modern system needs. Dry processing commonly refers to diazo materials although thermoplastic and electrostatic recording are also accomplished without conventional wet film methods. These are more logically treated in the discussions below of Schlieren and electrostatic systems.

There are no major large-screen, computer-oriented systems available that utilize a complete wet processing method. The reasons for this have been the high heat absorption in the film gate, the necessity for drying the film prior to projection, and the lack of stability of the film base material. A number of major systems, however, do use the fast response and high resolution of silver halide for the generation of the negative film and then contact print the final positive on diazo type film.

The characteristics of Kalvar film are as follows:

Spectral response - 3325 to 4325 Å

Light source

CRT

high pressure mercury arc

xenon flash

Sensitivity - 0.16 watt-sec per square cm

Resolution - 200 lines/mm

Processing - heat at about 240°F

Projecting - dispersion rather than absorption.

The Kalvar film utilizes a dry diazo emulsion on a transparent film base. Exposure to ultraviolet light creates a latent image in the form of microscopic pressure centers in the emulsion. When the film is

heated to about 240°F, the emulsion softens and the pressure centers permanently distend the plastic material by expanding into gas pockets several microns in diameter. The resultant spheres refract and scatter the light from the projector. This is in direct contrast to the absorption characteristics of silver halide film and partly explains the higher stability through the relatively low heat absorption in the projector or film gate of the Kalvar film. Kalvar film is relatively insensitive and requires considerable energy in the ultraviolet energy region for exposure (0.16 watt-second per square centimeter in the 3400 to 4400 Angstrom region). An approximate equivalent ASA rating is  $10^{-7}$ . This characteristic has prevented conventional CRT exposure directly on the Kalvar film. The CRT as it is utilized for symbol and line generation is described in Section C. 2. a. 1. on console displays. The CRT is a familiar element of electronic technology and because of its characteristic of extremely low electron beam inertia, as compared to mechanical systems, provides an almost real time response to the appropriately coded and converted computer output. Silver halide film is sensitive enough to the CRT output so that a less than one second exposure is adequate.

The schematic flow diagram for the system designed for the Army Tactical Operations Central (ARTOC) is given in Figure 1. A magnetic deflection 5-inch CRT provides exposure for the black and white silver halide film provided in bulk roll film which is automatically fed to the exposure and processing station. The negative processing time is about five seconds. The processing is accomplished by forcing the three fluids (developer, fix, and wash) into a very thin chamber adjacent to the film. About 0.2 ounces of liquid are needed for this operation. The positive film is Kalvar diazo. The print consists of a clear line image on a semi-opaque background which appears black when projected on the screen. The 35 mm base is cemented to a steel holder which is notched for automatic storage and retrieval.

The group projector provides a 7 by 9-foot image from an 1800 watt xenon short arc projection lamp. The projection system utilizes a beam splitting arrangement which provides illumination for five projection gates. Four of these are for the overlays generated as

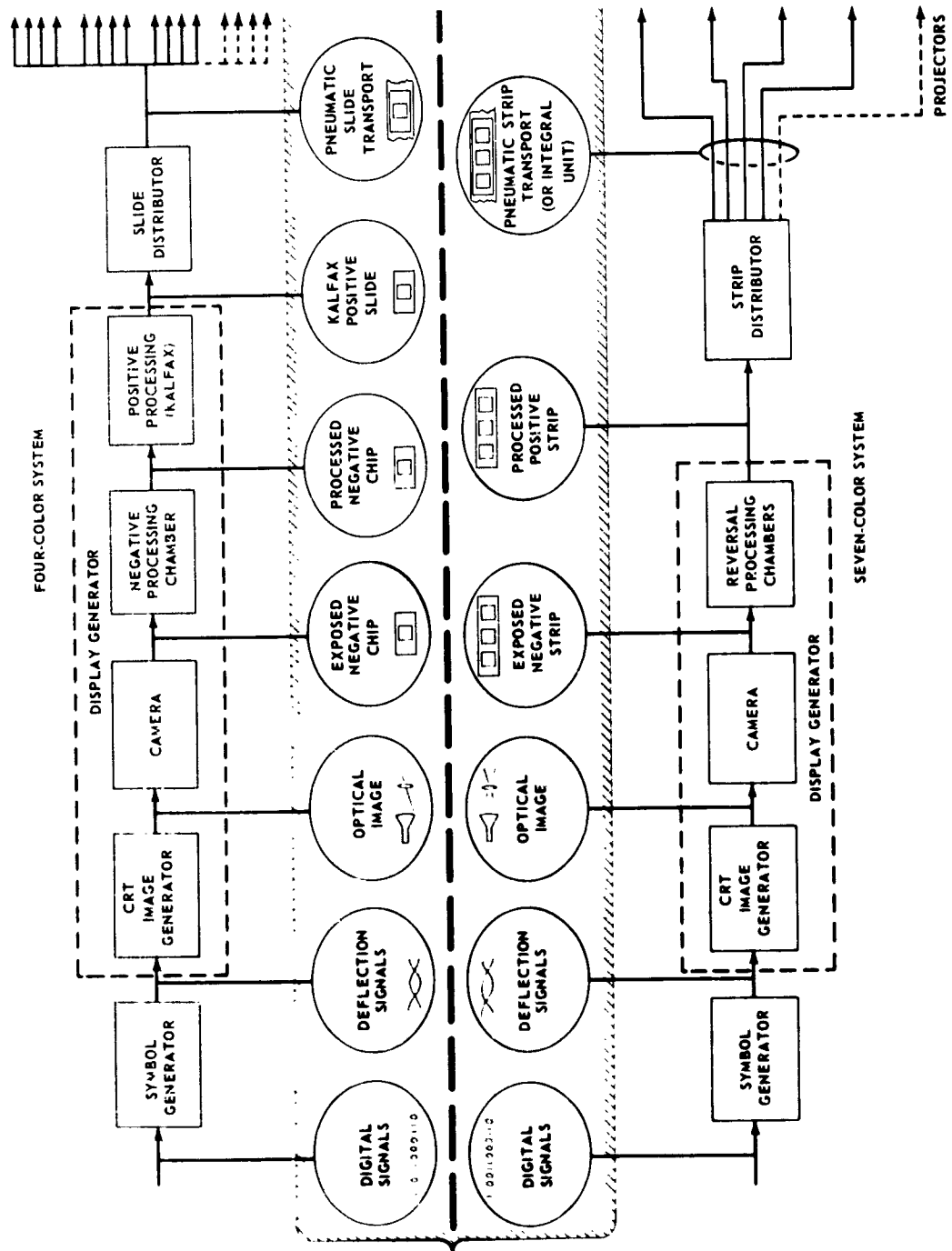

Figure 1. Flow Diagrams of Artoc Display Subsystems

described above while the fifth one is utilized for the projection in full color of the background reference slide (map or chart). The colors provided by the dichroic mirrors are red, green, and blue. In addition, two white light beams are utilized for the fourth overlay and the full color transparencies. Either rear or front projection may be used. Additional colors may be realized through the utilization of additive mixing. This produces seven colors including white for the dynamic data on the screen.

A system utilizing completely dry processing was developed for the Department of Defense Damage Assessment Center (DODDAC). In this system, ultraviolet exposure on Kalvar is accomplished through the use of symbol stencils inserted into the appropriate position in the ultraviolet path. The film is moved to provide X-Y locations and a contact print is made with a selected silver halide background in order to produce the composite Kalvar chip which is then projected. The penalty paid for the all-dry processing features is increased response time of the system necessitated by the actuation of the electromechanical symbol stencils.

A recent advance in the mechanization of wet processing may permit the utilization of this technique for both console and group projection systems. The film is black and white silver halide and may be either conventional or reversal film. Reversal film provides a clear image directly through the use of a bleach rather than a fix chemical solution as part of the processing cycle. The film is advanced through seals into the chemical solutions which are continuously cycled through a simple vacuum pump system. The last station, which consists of the wash solution, now also serves in the dual and significant function of "wet" projection. The clear wash water is not seen on screen. This eliminates the requirement for drying the film prior to projection and simultaneously provides the necessary cooling for the highly absorptive silver halide film. If 70 mm film is used, four framelets corresponding to the four different projection gates from the single white light source provide the dynamic color requirements in an analogous fashion to the ARTOC system. A separate projector is utilized for the background transparency. The film transport is provided with a dryer so that after

projection subsequent retrieval of the information is possible. The use of the reversal film provides clear images on the opaque background without the light flooding of the background that would result from the projection of opaque characters on a translucent field. The response time of the system is approximately ten seconds. The basic resolution of the film of 80 lines per mm provides on-screen resolution quality that is in general comparable with the capabilities of the human eye (about 2000 optical lines total).

## 2. Electromechanically Driven Display Systems

By using electromechanical elements in the display generation cycle of a system, a tradeoff is made between the slower response characteristics of the moving elements and the freedom from film handling and processing. In addition, the use of accurate elements theoretically provides the possibility of very high accuracy in location and track data although this has proved difficult to accomplish in practice.

A number of systems utilizing electromechanical manipulation of symbols and optics have been built and are now in use. Perhaps the best known version is the Iconorama system. The elements of this system are illustrated in Figure 2. The basic element is a miniature 1-mil radius stylus, mounted in a rigid transparent plate, that transcribes a projectible record on a glass slide which has been coated with an opaque material. The transparent plate (on lead screws) is actuated by X and Y axis servos which move the stylus in response to appropriate drive signals. The slide is located at the image plane of a projection lens system which is illuminated by the light source and this makes possible the projection of the enlarged scribed image on the screen. A solenoid retracts the stylus plate for starting and stopping a plot. Multiple color plots are provided through the use of multiple projectors which form a composite display. The stylus may be driven to form special stroke type symbols or alphanumerics in order to annotate the record. Three dimensions may be provided through the use of conventional stereo offsets and polarized or colored glasses. The use of this technique necessitates the change from a full field of previous history to a new blank record when the scribed surface becomes too cluttered

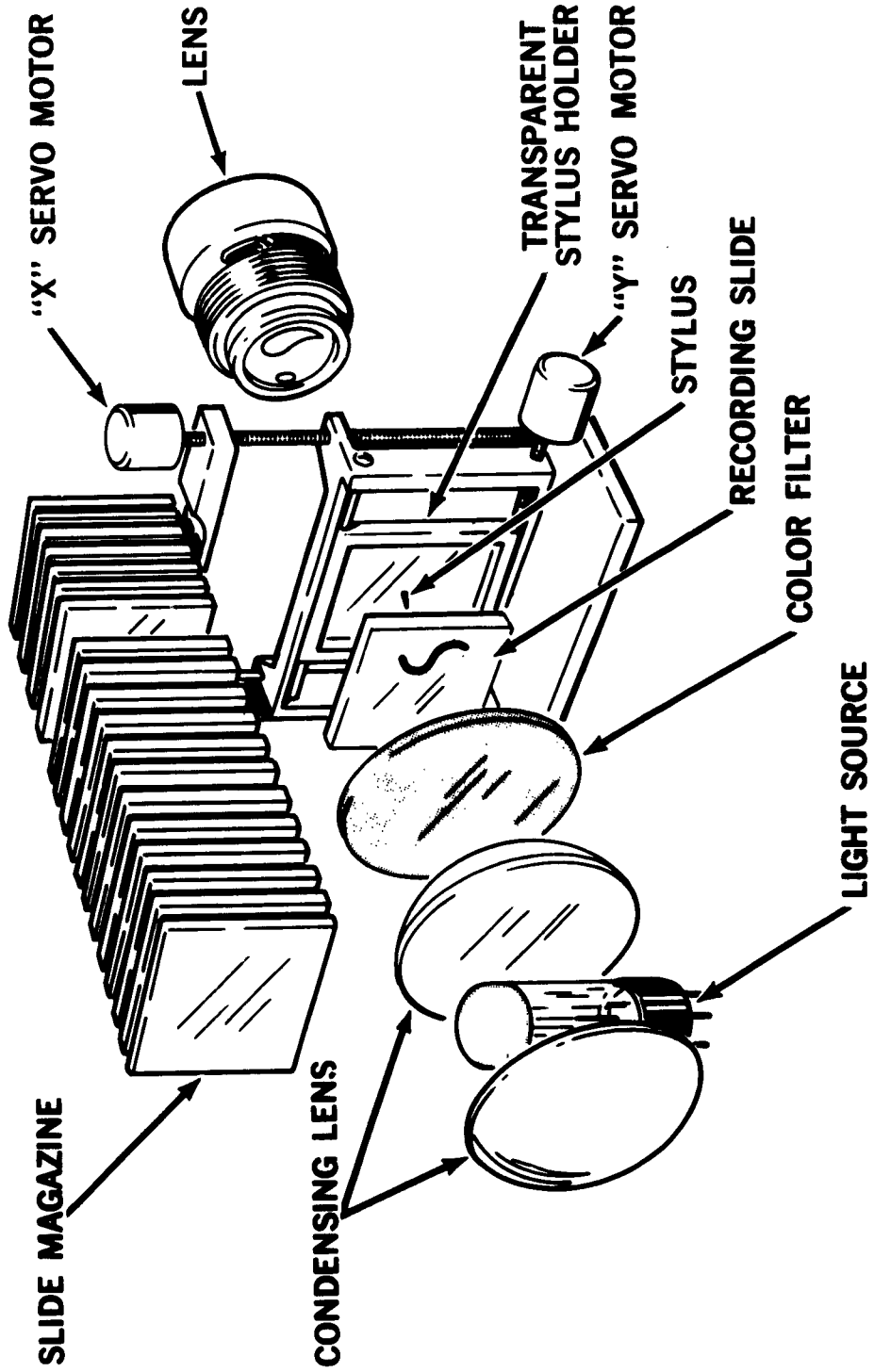

Figure 2. Iconorama

for continued use. In addition, the storage and retrieval of completed data becomes difficult. The keystoneing associated with the use of multiple projection units coupled with the slow response of the system prohibits its use in certain command and control environments.

Other electromechanical systems include the actuation of rotating drums with characters or words to coded positions similar to those used in stock market status rooms. A relatively new and inexpensive approach uses elements in a matrix that are silvered or painted white on one side and opaque or black on the other. Each letter is then formed by driving the necessary elements in the matrix to the proper position. This provides a faster response than stock type indicators but is still relatively slow and is not characterized by random access location or vector drawing capability. Its principal military use falls into the category of weapons or aircraft status reports.

An entirely different kind of electromechanical display under development was reported at the 1963 National Convention on Military Electronics. It consists of independently controlled "venetian blind" elements through which light from the backside is allowed to pass or blocked depending on the position of a magnetic vane. The vane is switched and latched into place by control of the current polarity which magnetizes it within the field of a small permanent magnet. Three such elements stacked vertically, and associated with primary color filters, are packaged in a quarter-inch square unit. Full color displays with switching speeds to 60 cps are claimed. The number of elements to be provided (and switched) for a full display must correspond to the number of pictorial elements needed.

### 3. Projection CRT Systems

Theater-television equipment has been available for a number of years in the form of forced-air-cooled projection kinescopes. They may provide picture information for screen sizes up to 20 feet by 15 feet. The tube contains a high efficiency aluminized white fluorescent screen which produces a focused spot of high intensity brightness. Typical tubes use a combination of magnetic deflection and electrostatic focusing. The tube must be used in conjunction with a typical (Schmidt)

spherical collecting mirror and correcting lens located at the mirror center of the curvature. The system is capable of providing television quality pictorial information to a theater audience but, in spite of its real time response characteristics, is impractical for a military computer oriented display system for the following reasons (a) The unit must be used in a fairly dark room as only about 2 to 4 foot-lamberts are available on screen. (b) The resolution of the system is of the order of 800 television lines which is equivalent to 400 optical line pairs. This is considerably poorer than the 2,000 to 4,000 optical lines available with a film base system. The resultant degradation of alphanumeric and track data would prevent efficient operations in large scale military or space control centers. (c) The tube life is only 150 hours. (d) There are problems connected with the use of the rated 70,000 volts in a military system environment. These include X-ray radiation and corona associated with marginal dust, humidity, and tube mishandling. The tube must be operated at stated intervals for conditioning and is subject to internal arcing or screen damage in the event of accidental overscan or scanning failure. (e) The light output decreases considerably over the lifetime of the tube because of face discoloration during normal operations.

Other projection systems include opaque projection of dark trace tube images. The screen material contains salts such as alkali halides which are normally white. However, when hit by the electron beam, they become dark at the area of contact. This image may be illuminated and magnified using a conventional spherical mirror light source and Schmidt correcting plate. The tube is characterized by only moderate contrast and resolution equivalent to television images. Erasure is accomplished only through exposure to radiation of the appropriate wave length thus necessitating an additional control parameter in the system.

#### 4. Schlieren Projection Display Systems

The modified Schlieren optical system uses variations in the refraction of the light beam caused by deformations in the Schlieren medium to create the desired image. In the two systems considered here, the deformations are formed as a result of electrostatic forces

introduced by the direct impingement of the electron beam on the medium. The mediums considered are oil film for the light valve projector and thermoplastic tape.

The essentials of the light valve projector are shown in Figure 3. The main features of the technique are real time visible light modulation and simultaneous projection of the information as well as the availability of greater screen brightness over that available from projection CRT's through the use of an external light source. The medium is a transparent layer of oil whose refractive index is greater than unity. The electron beam is driven by the usual symbol generator, deflection drive, and line drawing control circuits. The deformation of the surface caused by the electrostatic forces (see Figure 4) causes refraction of the rays. The collimated rays passing through a nondistorted surface pass straight through. These nonrefractive rays are blocked by the aperture disk and, therefore, do not appear on the screen. The refracted rays bypass the disk and are collected and focused on the screen to provide an image of the same information as that produced on a conventional CRT. The persistence of the display is a function of the rate at which the deformation subsides and this in turn is dependent upon the conductivity and viscosity of the fluid. Thus, the persistence of the image can be varied in order to minimize objectionable flicker effects and permit relatively slow rewrite rates.

The same general principle used for thermoplastic recording is shown in Figure 5. The film consists of a high melting point base film coated with a transparent conductor which has a thin film of a low melting temperature thermoplastic on its surface. The film is heated to the melting point of this thermoplastic and the electron beam is used to provide the deformation in accordance with the information to be stored. The film when cooled below its melting point freezes the information deformations. The optical system used for projection is shown in Figure 6. A series of line light sources are imaged on a set of bars (corresponding to the disk) when no deformations are on film. The ripple or deformation will produce a corresponding light spot on screen where the intensity is proportional to the depth of the ripple. Color may be produced by utilizing deformations in the form of phase

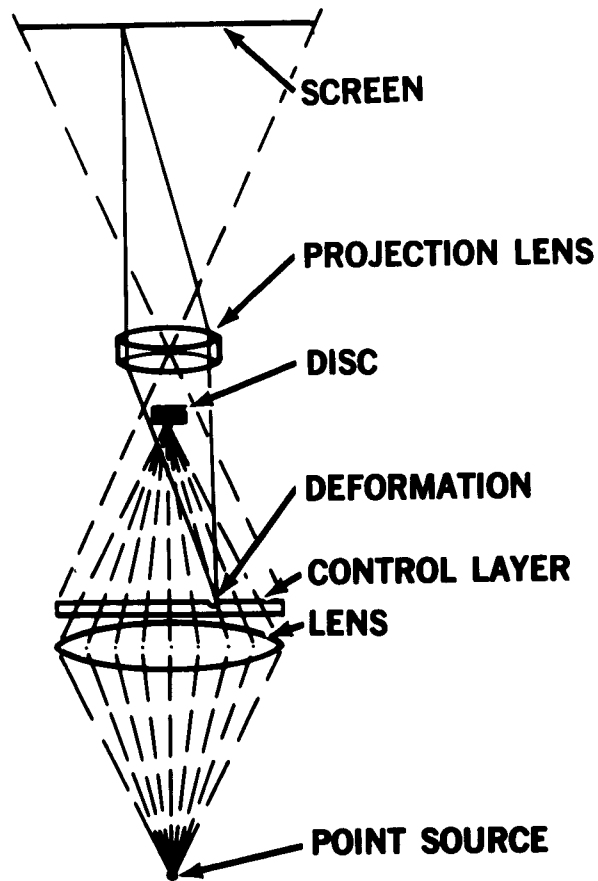

Figure 3. Light Transmission Through Control Layer  
for Light Valve System of Large Screen Projection

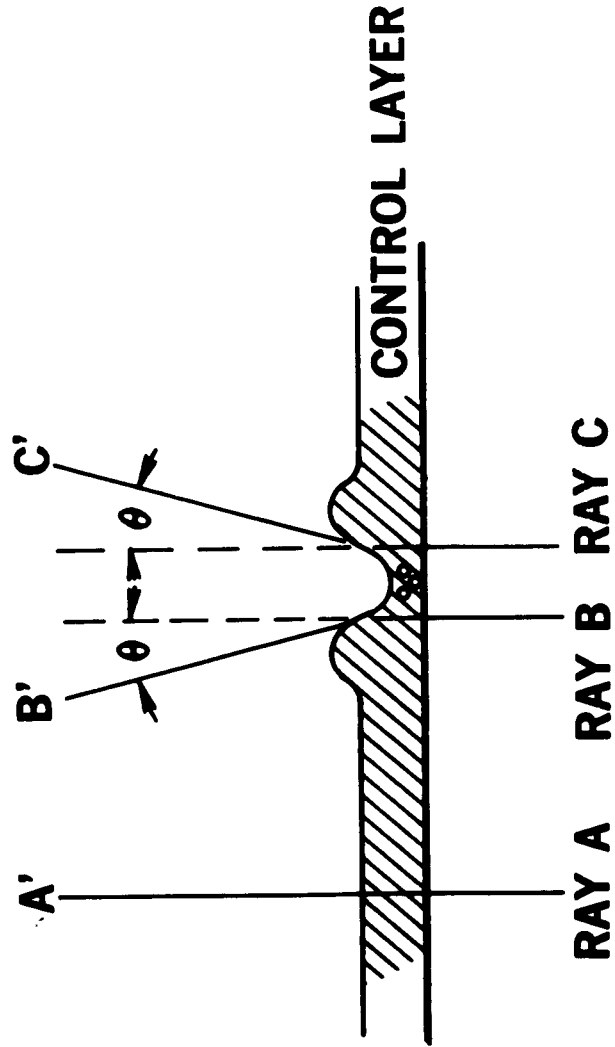

Figure 4. Control-Layer Deformation

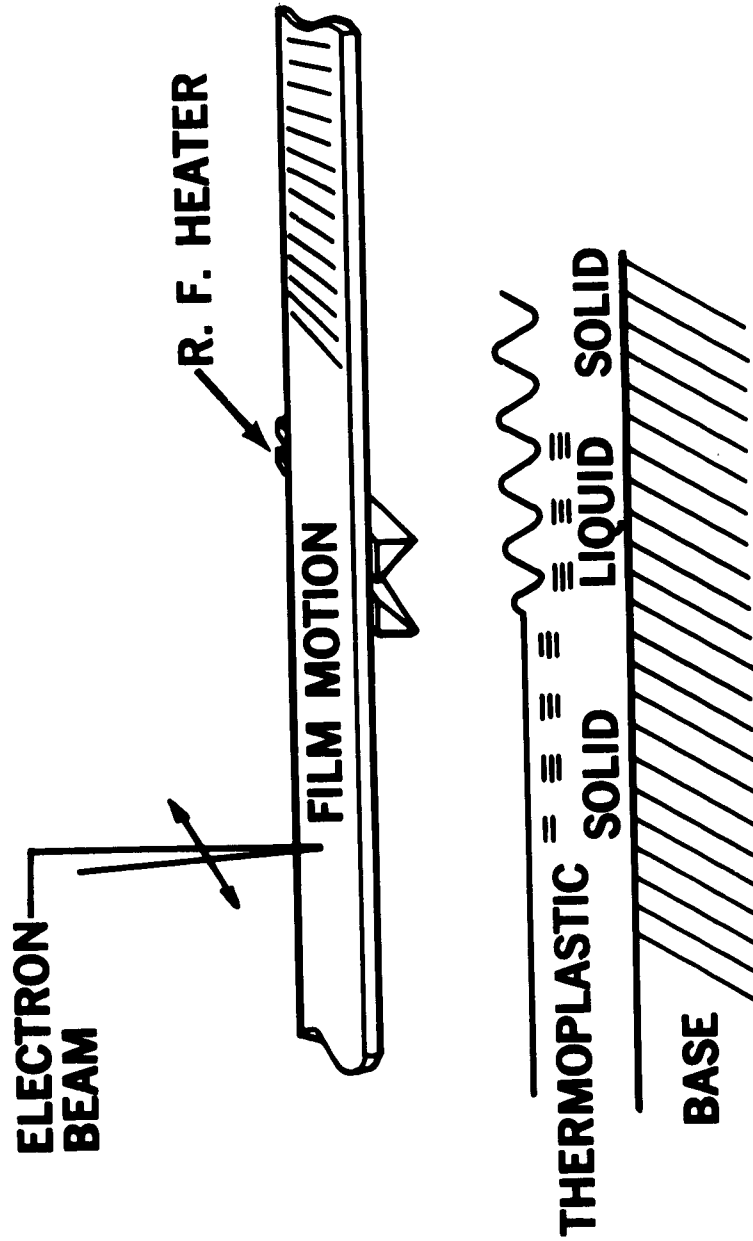

Figure 5. Mechanism for Thermoplastic Recording, and Cross-Section of TPR Tape

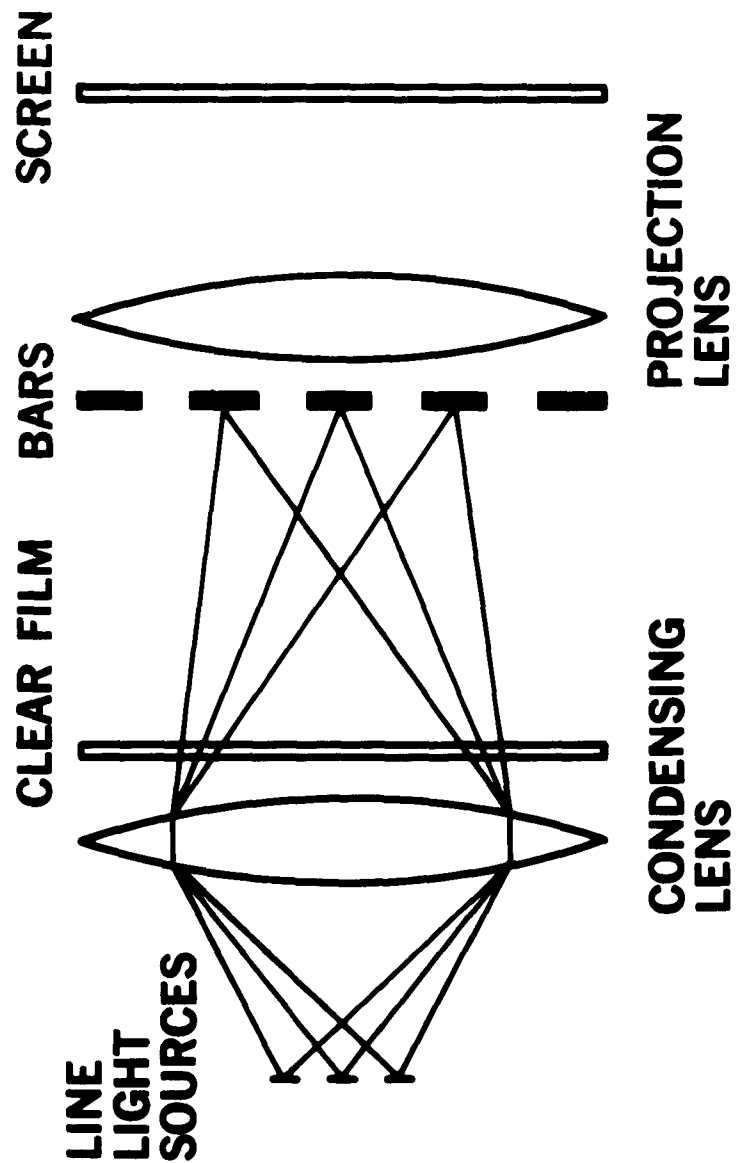

Figure 6. Projection System Suitable for TPR

diffraction gratings (see Figure 7). The slots in front of the projection lens are narrow enough to admit one primary color. The spacing of the grating, therefore, determines the color; the dimensions of the grating, the intensity. The problems associated with the use of this equipment are associated with the passage of the film in and out of the vacuum chamber, the cooling of the film in the vacuum chamber, and the scratching of the film surface during transport. The advantages include real time presentation and a reusable film medium as proper heating of the film without electron beam bombardment will erase previous deformations.

The Schlieren optical system has been successfully applied to the Ediphor television projector whose present technical features are summarized as follows:

#### Performance Characteristic

Light output - greater than 3,000 lumens  
(actual picture brightness in foot-candles  
multiplied by picture area)

Absolute contrast - 100:1

Resolution capabilities - better than 1,000  
lines (as measured using a standard TV  
resolution wedge)

Geometric distortion - less than 1 percent  
(as measured with the RETMA linearity chart)

#### Light Source

Type - 1,800-watt Xenon enclosed arc lamp

Lamp life - 1,000 hours

#### Optical System

All elements have low reflection coatings

Infrared transmitting mirrors used as heat  
filters

Objective lenses are available for projection  
ratios of 1:1 through 1:7

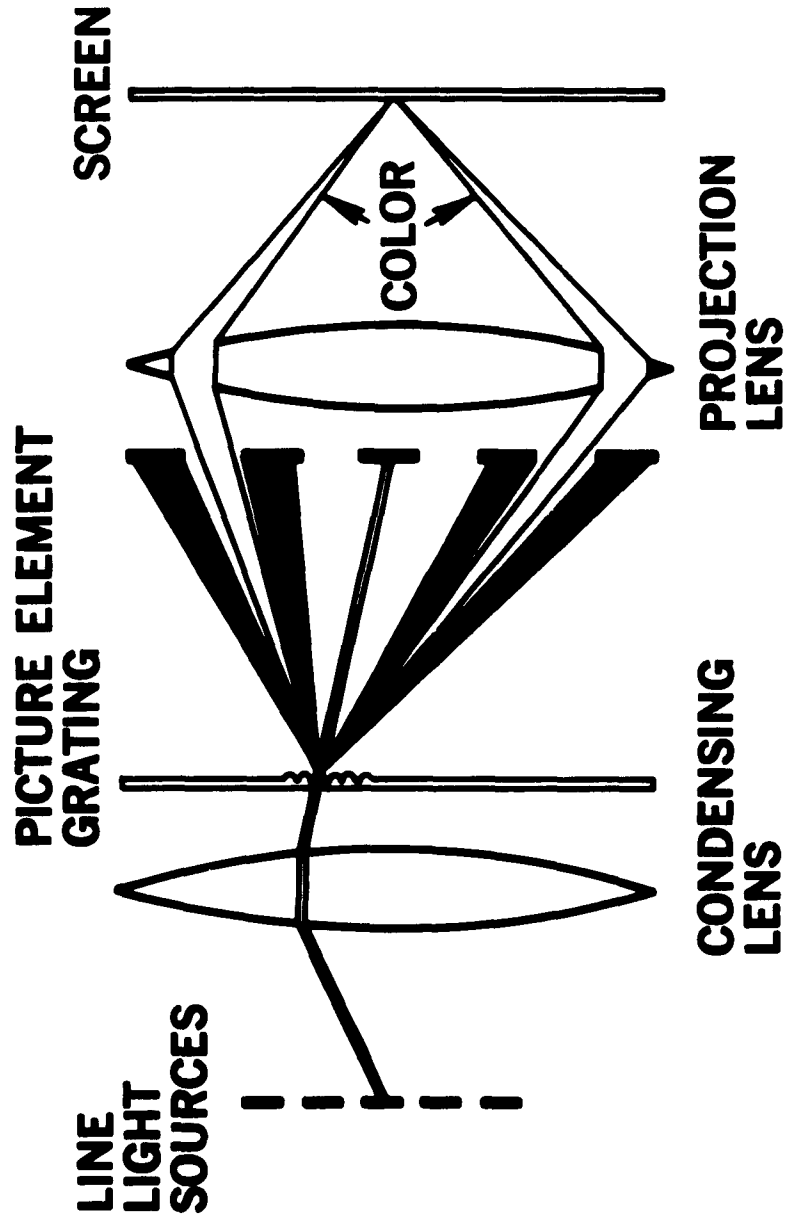

Figure 7. Color Projection Using TPR System

### Electronic System

Beam deflection - electromagnetic  
Picture modulation - electrostatic  
Blanking - electrostatic  
Gun cathode life - 400 hours each (1 active  
plus 2 spares)  
Gun cathode change time - approximately  
2 minutes

### 5. Electrostatic Display Systems

There are two basic techniques of interest associated with the production of a latent electrostatic image in the form of a charge pattern on a nonconducting material. The xerographic method uses a CRT to convert coded data into an optical image at electronic speeds. The image is focused onto the precharged photoconducting surface (vitreous selenium). This plate is a good conductor in the presence of light and, therefore, provides selective discharge in accordance with the desired information. The exposed plate can be developed by passing a toner over it which adheres to the charged portions of the plate by virtue of electrostatic attraction. This may then be projected in a flicker-free fashion on the viewing screen. The use of multiple plates and color filters permits the generation of color display. The problems associated with this system are temperature sensitivity, toner contamination, storage, and retrieval. The display must either be projected directly from the toner dusted plate or transferred to a film or paper base with attendant loss of response time and resolution.

Another electrostatic system utilizes the conduction of the charge through wire grids in the glass surface of the CRT. The film is placed against the wire grid external to the vacuum. After being charged the exposed film is brought into contact with an oppositely charged powder. This adheres to the film in the shape of the required visual image. The image may be fixed by heat, pressure transferred to another medium, or erased. The powder may be opaque to visible light and thus produce a negative image which can be contact printed prior to projection for display purposes. The wire grids may be as thin as 1 mil and spaced as closely as 500 per inch.

## 6. Photochromic Display System

Photochromic coatings consist of reversible light sensitive dyes in high resolution coating material. The material requires no development as the image appears when constituent molecules are switched from the light transmitting state to the light absorbing state, or vice versa, by energy of the proper spectral distribution. Present materials switch to color when exposed to near ultraviolet and clear when switched to the inverse state with heat or other proper illumination. Photochromic systems are characterized by high resolution (greater than 500 lines per mm), erasure and rewrite capacity, and no processing. The disadvantages are the necessity of high light intensity for exposure and the wear of the photochromic materials after about 1,000 reversals.

The general mechanization for a photochromic system is illustrated in Figure 8. A writing beam of near ultraviolet light is servo positioned to illuminate the photochromic material which will then appear dark. Additional plots may be provided by the use of additional lights or time sharing of the sources. Background data is provided through the use of reference slides.

### b. Detailed Description of a Specific Display System

The Department of Defense Damage Assessment Center has been assigned the dual mission of providing peacetime assessment of the resources of the United States and foreign countries and in time of war the effect of nuclear destruction on all areas of the world. A full color large screen automatic display system was developed for installation in the Pentagon.

The system consists of four major and four peripheral modules (see Figure 9). The Control Programmer is utilized as an on-demand buffer to take information from the CDC-160 satellite computer which in turn receives data from the main CDC-1604 computer. The Control Programmer converts the data to a command and information structure and to a speed which the Display Generator can use. The Display Generator operates at a much slower speed than the computer as it utilizes electromechanical elements for symbol generation on film.

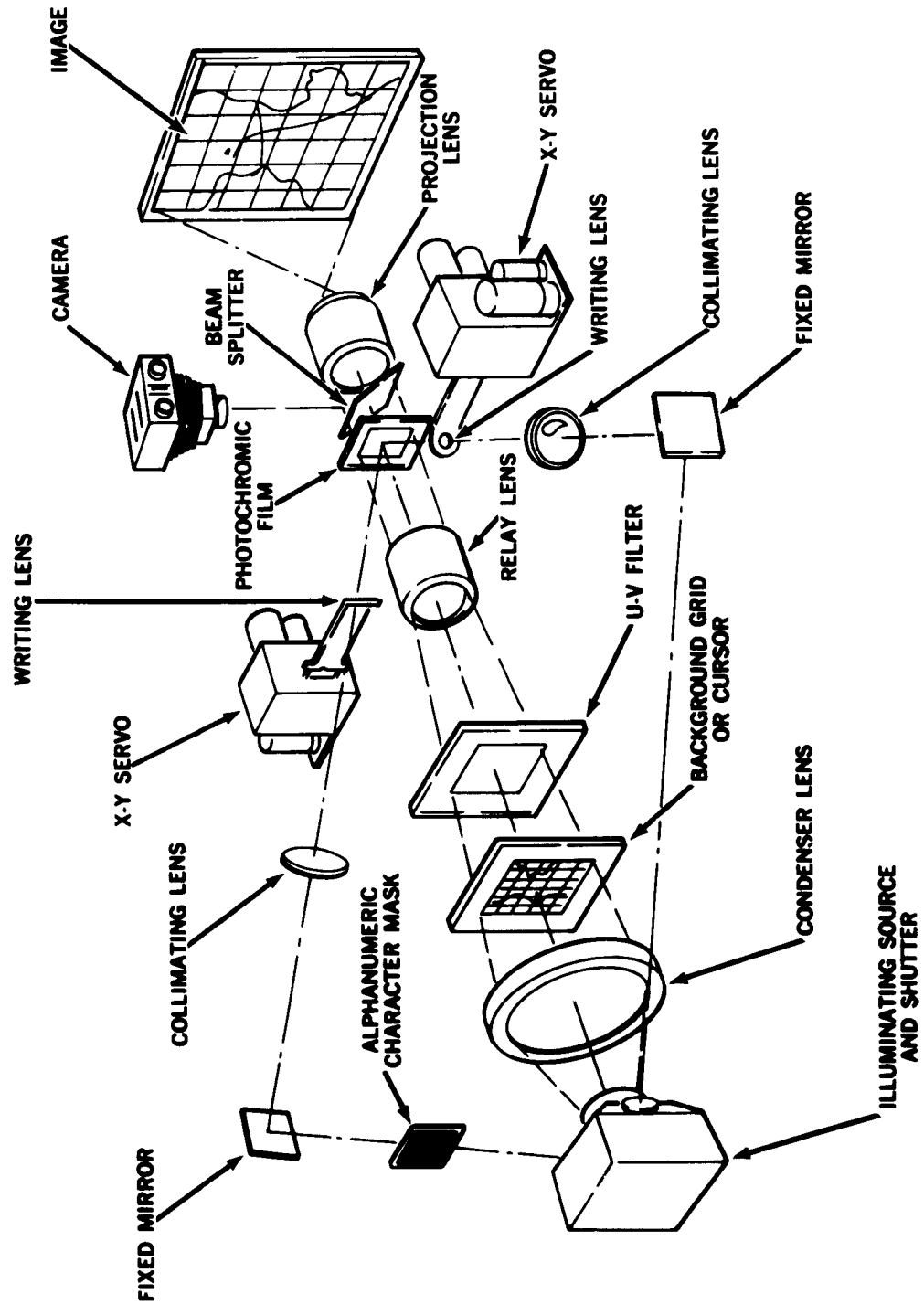

Figure 8. Photochromic Dynamic Display

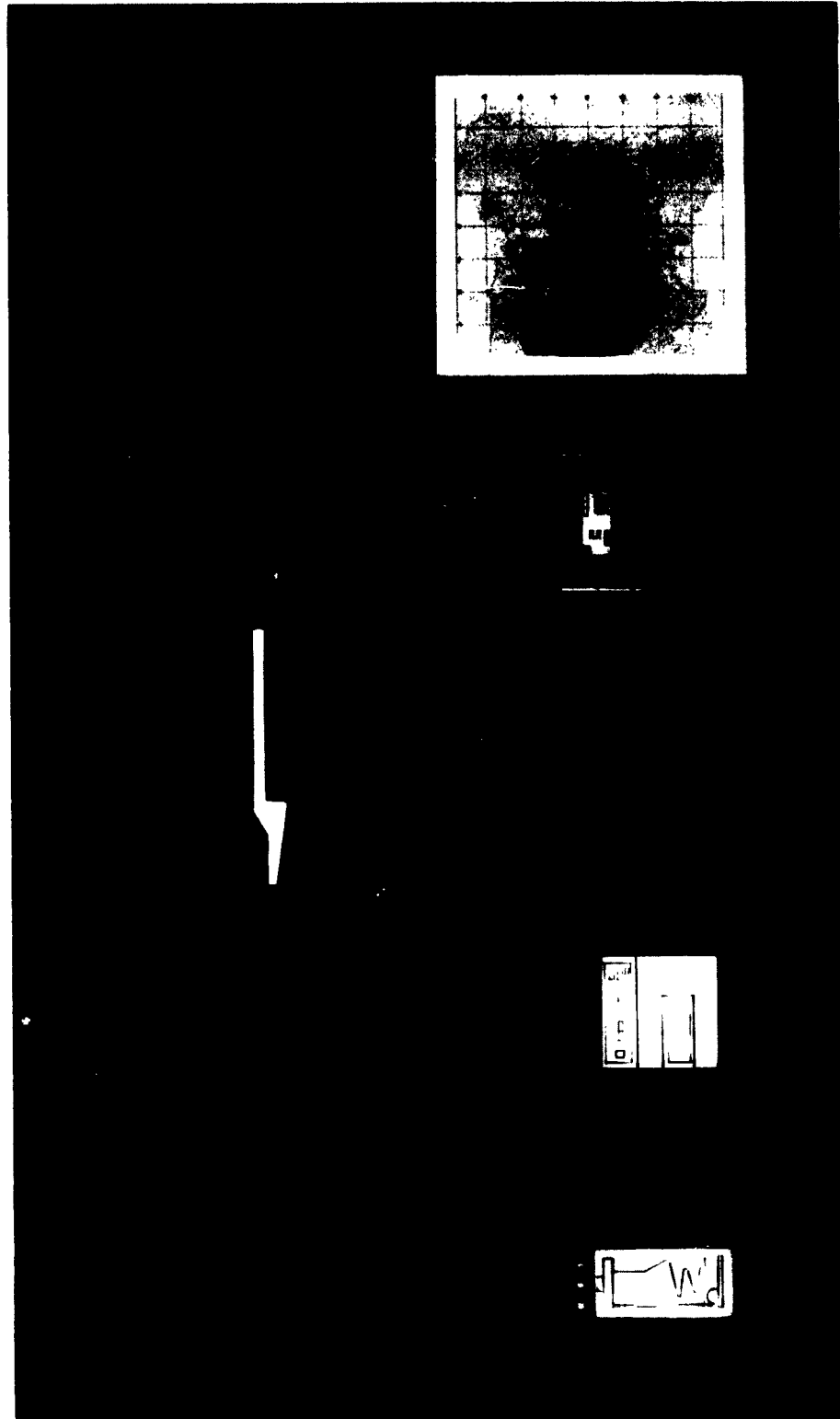

Figure 9. Large Scale Full-Color Display System

A conveyor provides transportation of the completed display slide to the Display Projector where it is acknowledged and filed for immediate or subsequent rear projection on an 8-foot by 10-foot screen. A copy camera reduces color reference material on an off-line basis to 70 mm three-quadrant black and white silver halide photographs. Each quadrant contains, in gray tones, the contributions from the primary additive colors of red, green, and blue as viewed by the filters in the unit. The copy camera outputs are stored in the Display Generator where they are available for subsequent contact printing on Kalvar with superimposed dynamic data.

The Display Generator (Figure 10) contains a complex set of fully silvered and half-silvered mirrors which split the optical energy furnished by electromechanical symbol stencils in the mercury vapor ultraviolet path so as to produce three separate images on two 70-mm film chips. The symbol generation units each contain 16 metallic tapes which provide four different stenciled characters for a total alphabet of 64. There are five of these units operated in parallel which permits simultaneous exposure of up to five letter groups. All symbols are exposed on the mask film; only symbols in complementary regions are exposed on the final display slide. Three quadrants are provided for use in the projector of the three primary additive colors, red green, and blue. The permits the dynamic data to be provided in black, white, red, green, blue, cyan, magenta, and yellow.

During exposure of the dynamic updating data, the platform holding both the mask and display slide is servo positioned in X and Y to provide position data.

Lines and curves are produced through utilization of a stationary beam of ultraviolet light through an open shutter in the symbol generation unit while the film is moved in a controlled path by the servo system for the digital computer outputs.

The masking assembly contains an integral developing unit for processing of the exposed symbols and lines in all three quadrants of the masking film (see Figures 11 and 12). The developed mask, selected background negative, and the display chip (which now has the

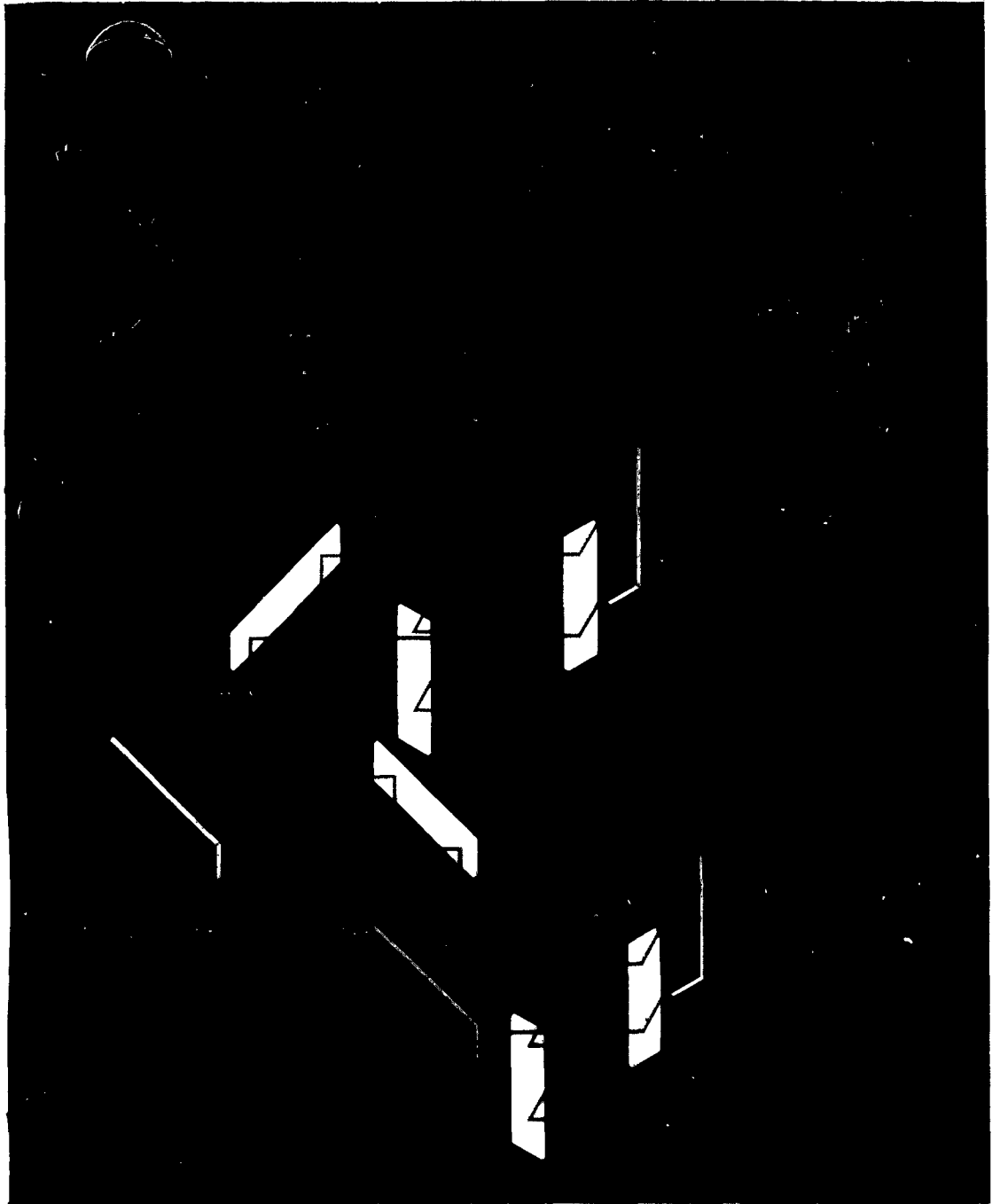
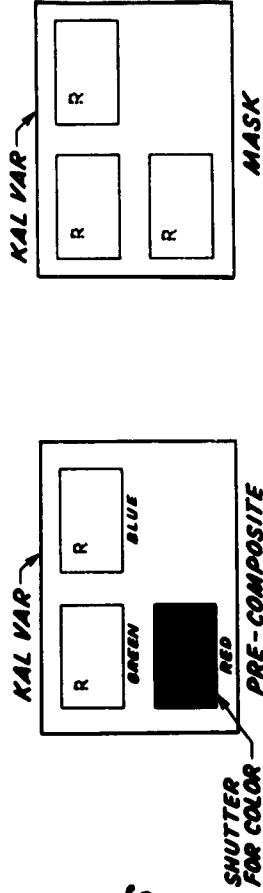

Figure 10. Display Generator Optics

# FULL COLOR DISPLAY CHIP GENERATION

## STEP I

**SIMULTANEOUS  
UV EXPOSURES  
OF ALPHANUMERICS  
ON MASK AND  
FINAL CHIP**



## STEP II

**HEAT STENCIL  
(DEVELOP)  
RETRIEVE BACKGROUND**

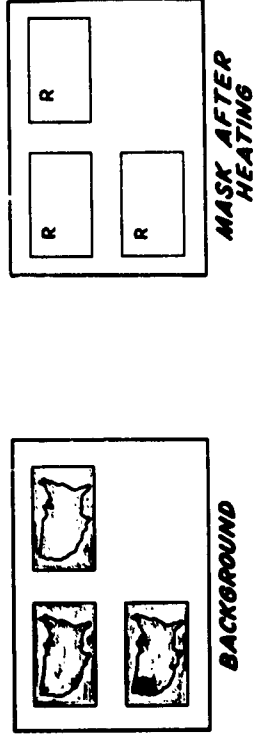

## STEP III

**FORM TRIPAC  
AND EXPOSE  
TO UV**



## STEP IV HEAT COMPOSITE

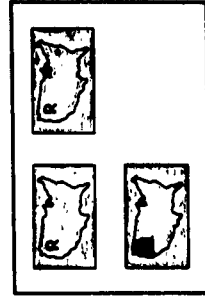

## STEP V TRANSPORT TO PROJECTOR

Figure 11. Full Color Display Chip Generation

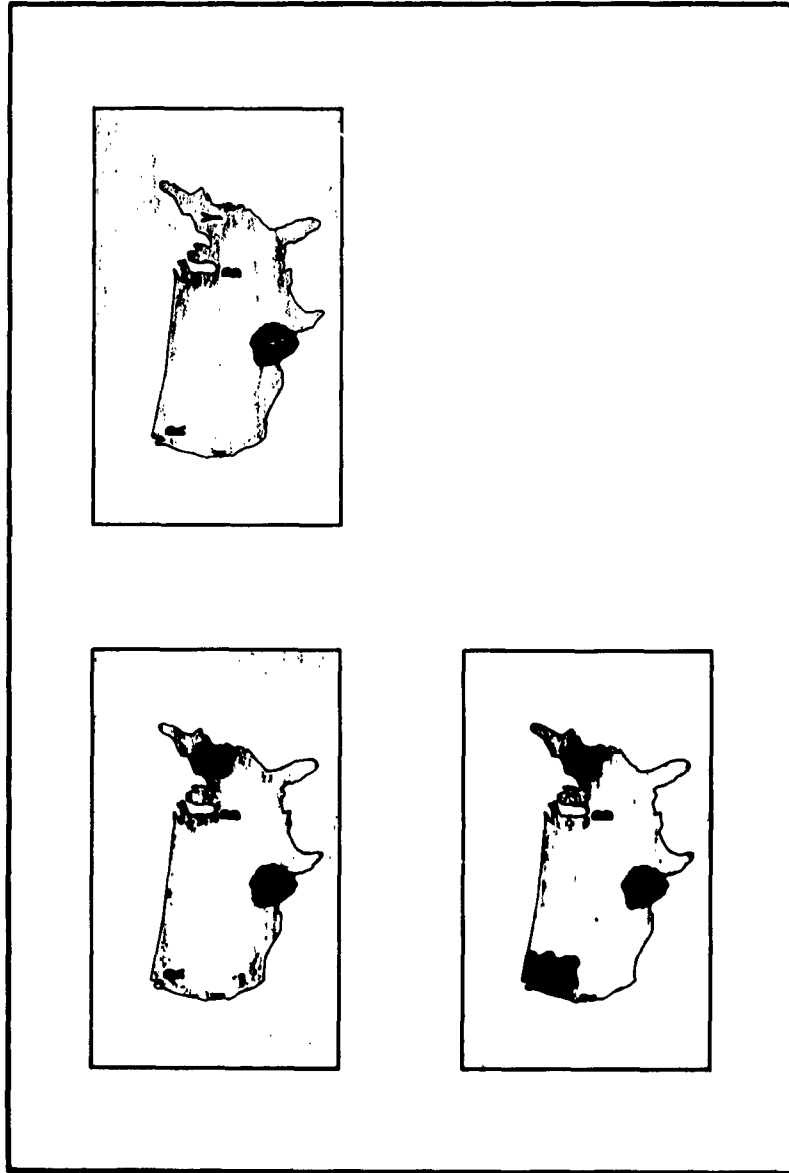

Figure 12. Composite Display Chip

annotations exposed but not developed in complementary color regions on it) are placed on registry pins in physical contact for a contact print. The ultraviolet printing unit transfers the background information to the three display chip quadrants. Where opaque images exist on the mask film, the ultraviolet light is blocked, creating clear windows on the final display chip. This display slide, after heat development, consists of three different image characteristics: (1) the grey tones for each color contribution of the background information, (2) clear windows through which the desired combination of primary colors are permitted to pass, and (3) opaque symbols which block the undesired component of the annotated information. As shown in the illustration, the red letter R is created by providing a clear window in the form of an R in the red framelet of the final display chip. The corresponding geometric regions of green and blue symbols (in the form of R's) are opaque. If a yellow R had been desired instead, clear windows in the form of R's would be created in the red and green framelets, with the opaque R placed in the corresponding position of the blue framelet. Because of the utilization of the mask, no background information is present in the display chip within the area defined by the symbol strokes. The additive method of color mixing is employed, requiring the use of the colors red, green, and blue.

The unambiguous color in this system (see Figure 13) is derived from this special masking technique which eliminates the color mixing of background and annotations associated with systems using separate projectors. It is an important feature of this system that regardless of the color or intensity of the background or the color of the annotation symbol when using the mask, no color mixing can occur. Thus, when the input calls for a yellow symbol on a blue background, that symbol will appear in its exact shade of yellow on the display screen instead of mixing with the blue background to appear as a greenish symbol color.

The Control Programmer accepts computer processed data for on-line generation. The seven-bit word length control-signals for the creation of display film chips include the selection of the background, the selection and position data of symbols, designation of a color for symbols or lines, position data for curves, film processing, and chip

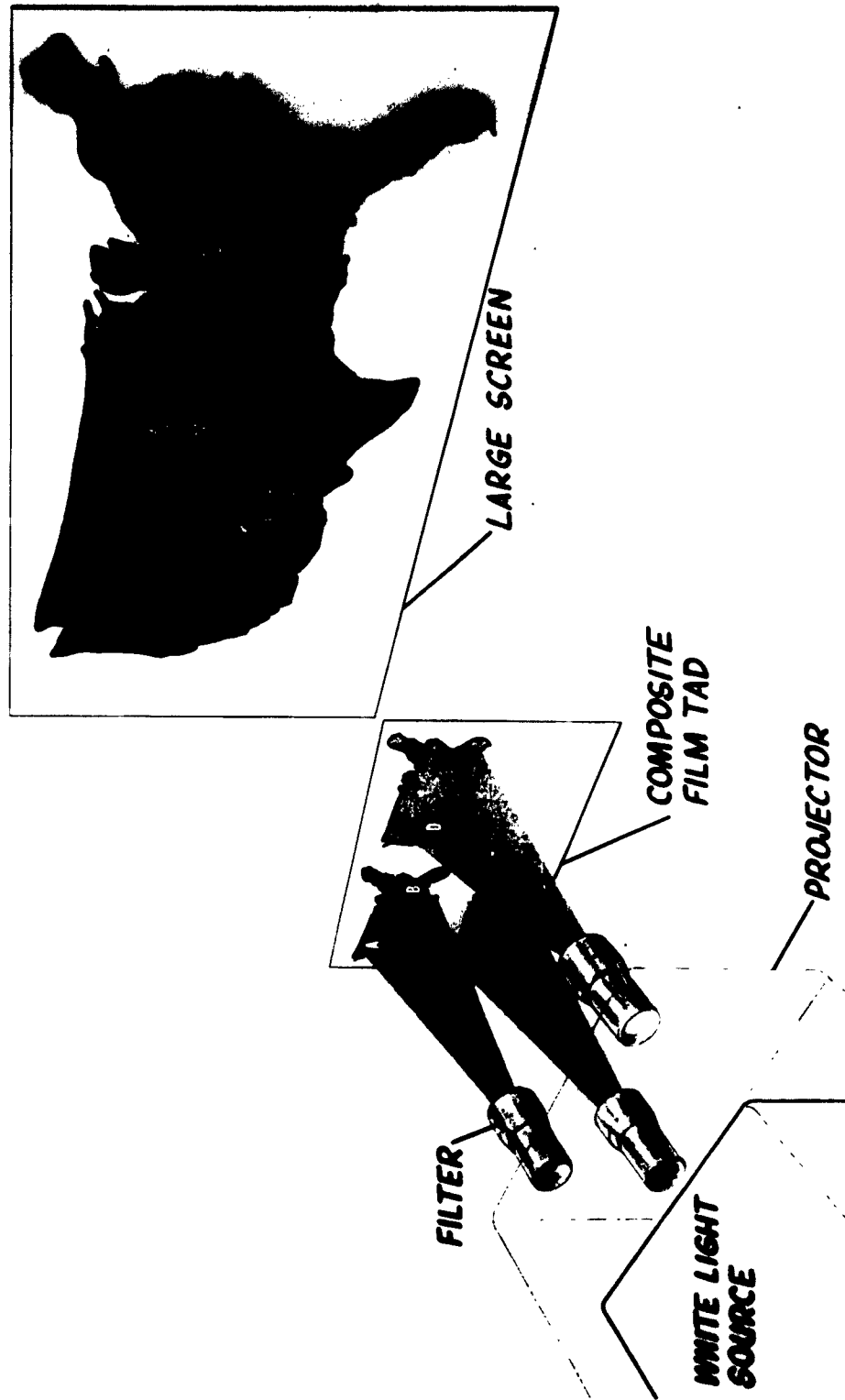

Figure 13. Full Color Projection System

destination. A gravity feed shift register provides temporary data storage as well as status indication to the computer as to the availability of the display system for the receipt of further data. A paper tape reader is integral to the unit for providing off-line digital input signals to the Display System.

The Display Generator is characterized at present as requiring 0.650 second for each five-character exposure. The exposure of 100 symbols, therefore, would require 13 seconds. Overhead film handling operations add 42 seconds for each chip. Thus, a typical slide with 100 updating symbols could be produced and projected in 55 seconds which includes an optional 10-second stop for standard 35 mm color duplication record. The placement accuracy of the entire system is 0.1 percent, which thus provides a maximum error of 3 miles in 3,000 miles. On a 10-foot screen the error is in the order of 0.1 inch. As the symbols are over 2 inches high, this is relatively insignificant.

The projector can be operated either under system control or independently under manual control. Controls are panel-mounted directly on the projector and duplicated on a remote control unit located in the viewing room. The registration accuracy between background projection and updating data projection is achieved by combining the information on a single film chip rather than on separate films.

A Computer Communication Console provides the operator instruction path from the viewing room to the computer and its data base. Removable plastic overlays are coded for use with the computer of either special retrieval functions or ad hoc display generation.

Other components include the on-line Monitor/Analysis Console, which is an operator quality control station linked by the chip conveyor mechanism between the Display Generator and Display Projector (see Figure 14). The operator may approve a chip or request the system to reject it and then either regenerate it or proceed to the next chip.

The system is capable of being operated in many modes in accordance with computer or man-machine instructions. Product improvements in the form of more efficient ultraviolet sources, faster symbol

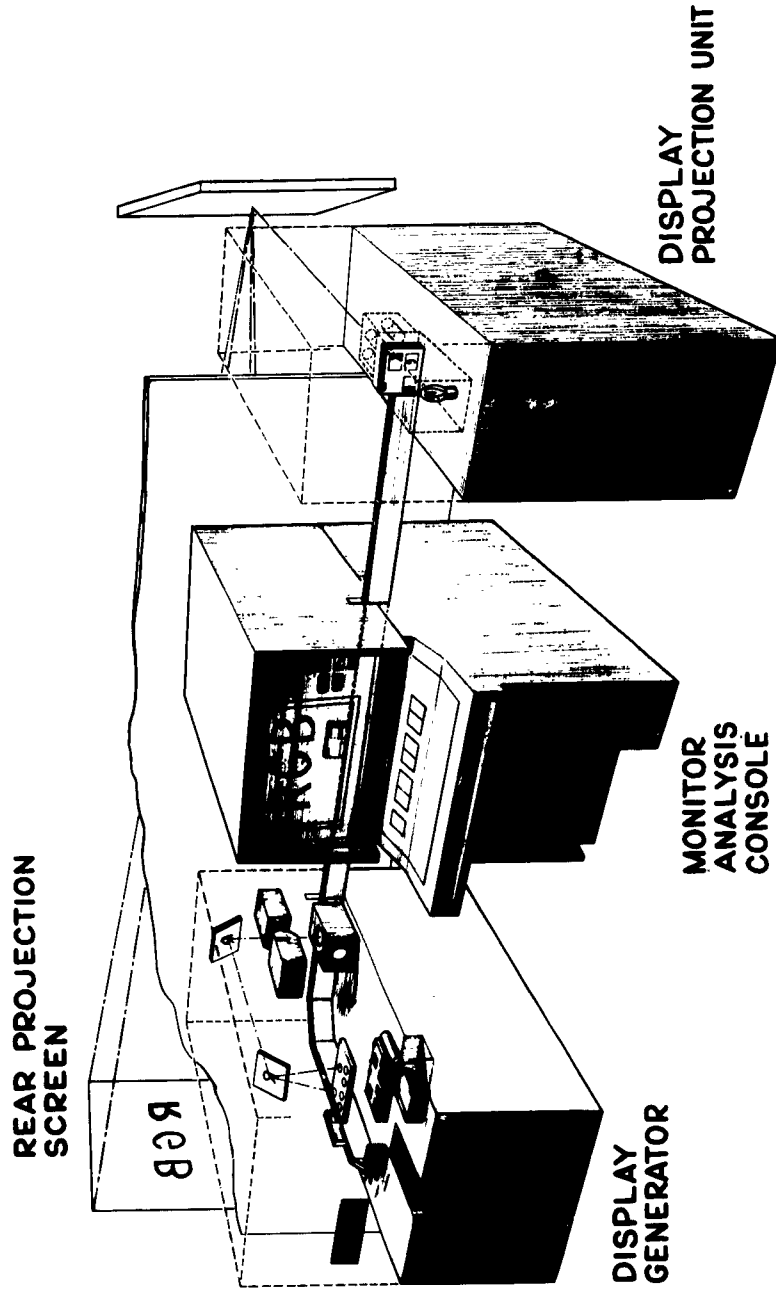

Figure 14. DODDAC Display Equipment

stencil movement, and heat platen pressure developers are now being prepared and are expected to reduce the system response time to one-half of its present value.

The system has the faults associated with all complex configurations of electromechanical elements. These include relatively slow response time and difficult maintenance for certain areas of the generators. The advantages include: all dry processing, no color mixing, high resolution, and targeting accuracy. This provides the data needed by DODDAC for the accomplishment of their particular mission. For a tactical environment involving high speed missiles, for example, it is obvious that a faster response time is required.

c. Interim and Advanced Concepts for Future Display Systems

1. Interim Systems

All photographic film based systems of necessity fall into the category of interim since the ultimate display will most likely be driven directly from the computer rather than through use of an intermediate storage media. However, this lies a number of years in the future. For this reason, research and development in the fields of rapid film exposure and projection systems continues at a high priority level.

2. Photographic Film Systems

The advantages of dry process, high resolution scatter type Kalvar film have been discussed above. The key disadvantage of relative film insensitivity has led to further investigation of techniques to increase the effective ultraviolet output of conventional CRT's. Early experiments indicated that CRT utilization could be improved through the use of a fiber optics faceplate with an increase in efficiency by a factor of approximately 90. Evaluation of a raster rewrite time converted into equivalent character stroke widths indicated that the tube would have to be driven at objectionably high accelerating voltages to produce sufficient energy in a meaningfully short time period. This has the effect of increased local heating problems, shortened tube life, and resolution degradation produced by tube face discoloration.

The output curves in the ultraviolet range for ultraviolet rich phosphors (such as P16) show an optical energy decay in the order of less than a microsecond after removal of the energizing beam. The physical construction of the CRT consists of the deposition of granules of the phosphor material on the glass (or fiber optics base plate). The conduction characteristics of glass are notoriously poor, which results in the decay of thermal energy following a "slower" curve by at least two orders of magnitude. Two methods have recently been advanced as an attempt to bypass the effect caused by the initial thermal peak produced by the excitation current repeated before conduction cooling is accomplished.

The first method consists of a diazo film holder positioned externally (not quite in contact) from the optically flat faceplate of the CRT. A motor drive provides a fixed offset rotation of the film assembly. The exact position of the film is not critical as a resolver furnishes the location of the film information to the deflection circuits. The beam then tracks the film precisely in a Stop Motion technique.

The size of the rotary motion is arbitrary as long as it is sufficiently greater than the character height to prevent overlap on the phosphor. The character deflection information is added to the Stop Motion information so that the only motion of the beam relative to the film is in the form of the desired alphanumeric and graphic data. The writing speed of the beam per character is about 10  $\mu$ sec and the character height about 25 mils. If the diameter of rotation is about 150 mils, then for the case of randomly positioned characters and lines created successively by the symbol or line segment generator (the rotation speed is nonintegral with the character generation speed), the return to any given character in the sequence will result in the phosphor of interest lying within a circular shell.

The effect of this approach permits the use of higher beam currents as the rewriting of the information needed to produce exposure will occur on a different phosphor surface area. The actual benefit is not linear as the ultraviolet output increases proportionately (approximately) with the square root of the excitation difference.

Probabilistic considerations coupled with total symbol or vector writing requirements indicate that the improvement to be gained from this approach coupled with higher ultraviolet output phosphors now available would permit approximately a 1-second exposure per framelet of display information. The advantages are the direct electronic speed writing of dynamic data on dry process high resolution film.

A system utilizing this approach needs more than one frame of data to provide a color full-screen display. If three frames were exposed simultaneously on a larger faceplate CRT, nonlinearities in deflection circuitry would result in the displacement of optical images that are supposed to superimpose on screen for color addition. The use of sequential exposures prevents this problem as the nonlinearities of concern in a short time period will repeat in position. Production of a complete display chip can be accomplished in approximately 10 seconds.

The second method consists of a high duty cycle exposure of the Kalvar through a specially constructed CRT.

If a continuous excitation of the ultraviolet source were practical, then the square law states that only a fraction of the energy required for rectangular pulse excitation would be required to achieve the same exposure results. For example, if a 1- $\mu$ sec pulse repeated every millisecond were replaced with a continuous energization, then the amplitude of the energizing source would be not 1/1000 of the peak but  $1/10^6$  under ideal conditions. Exposure of a spot continuously excited on the Kalvar film mounted on the fiber optics faceplate was realized experimentally with relatively low beam current and no degradation of the phosphor. The average duration or duty cycle on the CRT utilized in a conventional fashion coupled with short persistence characteristics mean that the given point on the film is actually energized a small percentage of the time.

The technique provides a means whereby the ultraviolet phosphors will be energized on a high duty cycle. The device consists of a standard CRT with a fiber optics faceplate and a phosphor characterized by long persistence as compared with P16. An image tube is constructed on the standard tube so that photo cathode material is

deposited on the other side of the fiber optics CRT faceplate. The anode end of the image tube contains the output fiber optics faceplate with P16 phosphor on it. The long persistence phosphor emits most of its energy in the long wavelength end of the visible spectrum and matches the spectral response of the photo cathode. The standard CRT will be utilized as the symbol and line segment generator. The light output will be maintained by the persistence and the refresh rate so that the photo cathode output will be constant over the refresh cycle. The photo cathode will, of course, in association with the expected contrast and signal-to-noise ratio emit electrons in the physical shape of the energizing symbols. These continuous streams of electron outputs are accelerated to the anode of the image tube by the appropriate voltage differentials and are focused on the anode by the focusing coils around the image tube.

The desired image, as stated above, is generated and refreshed periodically at a rate determined not by the retentivity of the human eye but by the input requirements for constant output of the photo cathode. The image tube serves to transfer and amplify the image to the P16 phosphor, which is illuminated at a high duty cycle. The ratio of peak writing time on the P16 to continuous energization will be in the order of  $10^{-7}$  ideally. As stated previously, the energy output of the P16 follows a square law effect and, therefore, the actual energy required on the P16 phosphor is much less for this particular application than that required by previous methods. The thermal buildup is then reduced to a safe level by the combination of no peaking transients and relatively low excitation. The mechanization described would, therefore, require the Kalvar film to be held in contact with the outer surface of the second fiber optics faceplate and the entire image would be exposed. This would permit exposure of the complete display in about 1 second. The system implementation would be the same as for the stop motion technique described above.

### 3. Advanced Direct Coupled Displays

The advantages offered by solid-state components in other electronic equipment directed attention to their use in display systems.

All of these devices for display are in the category of electroluminescent (EL) materials. The EL material or phosphor emits visible radiation upon the excitation of an electric field outside of a vacuum environment. EL light output is produced by sandwiching a thin film of EL material between two conductors, one of which must be transparent. The films in this elemental configuration are a few mils thick and require excitation voltage in the order of 200 to 800 volts. The light output increases approximately proportionately to the square of the voltage difference and the square root of the frequency difference. These characteristics, however, are interrelated and vary with different phosphor combinations. The usual frequency range is in the 400 to 5,000 cps range. Driving voltages are limited by breakdown potential considerations and frequency by the capacitance of the film structure as well as leakage excitation.

The key problem area for the application of these principles to a display system is in the storage and switching of the information. Alphanumerics or track data are provided through the selective activation of segmented portions of a 14-element matrix for each symbol. Two thousand symbols would, therefore, require 28,000-bit switching. A large wall display with vector as well as alphanumerics would require about 25 bits per inch for effective resolution. This in turn indicates a total storage and switching problem in the six-million bit range. The addition of color change capability requiring selection of other EL phosphor granules increases the problem complexity.

An evaluation of these techniques and progress over the past few years indicates substantial advances have been made in partially solving many of the problem areas. The light intensity for a given excitation frequency and voltage has been increased so that as much as 10 foot-lamberts may be considered to be available. This available light intensity, however, decays with use. The half-brightness life is in the order of 1000 hours. The temporary storage problem has been solved through the use of composite cell materials. If a display consisting of many thousands of elements had to be refreshed in a manner similar to a CRT, the switching rate would have to be multiplied by the eye flicker factor (about 30 to 45 cps) and this is essentially impossible.

The solution is the construction of composite cells. Each of these (light amplifier cell) contains a sandwich of transparent conductor, photoconductor, transparent conductor, EL phosphor, and transparent conductor. Once the device has been triggered ON the light from the EL phosphor is sufficient for feedback to the photoconductor so that the ON condition is maintained until the supply voltage is quenched. Another promising technique is the inclusion of a ferroelectric element whose capacitance changes with applied bias. The supply voltage appearing across the EL phosphor thus depends upon the control potential present on the ferroelectric element. The storage time is therefore a function of the leakage paths present. This system offers variable brightness range as well as a reduction of short term storage and transfer rates. It still requires, however, a large volume secondary storage.

Other switching schemes such as half-selection depend upon nonlinear characteristics of the display. Exciting a segment along one axis only compared with excitation along both axes results in a contrast at the actual intersection of about 100 to 1. This permits a cross-bar approach for switching technique but results in objectionable extraneous lower level light output.

The advent of extremely advanced or nanosecond computers may provide the means for information transfer necessary for direct non-storage EL actuation and refreshing, but of course this is a configuration that at present is little more than a vague concept.

## 2. INDIVIDUAL DISPLAY CONSOLE

Digital computing machines are especially good at doing a number of things. They have an accurate fast memory in which they can retain data or instructions. They have a high capacity input/output system, well adapted to other machines such as radar and guidance systems. They can compute accurately and rapidly. They can work for long periods without getting tired, do repetitious work without getting bored, and always react predictably even when they are "new on a job" having just been substituted for some other similar machine.

A man, however, is superior to a machine when it is required that he react intelligently to a situation for which he has not been trained. His intuition, when properly guided, can be a strong asset. No machines can even come close to man's correlation and pattern recognition abilities.

The function of a display console is to integrate a man-machine system so as to take advantage of the strong points of each of them. One might describe the console as an "impedance matching" device between the man and machines. The console provides for a maximum transfer of useful information in and/or out of a man. It improves system reliability by using the machine for all the jobs it can do well and by eliminating nonuseful information transfer to the man.

### a. State-of-the-Art Displays (Outputs to Man)

#### 1. Conventional Cathode-Ray Tubes

The most commonly used display device in man-machine communication consoles is the conventional cathode-ray tube. The displays presented on the face of the cathode-ray tube may be typewriter format or random format. Typewriter format displays are composed of alpha-numeric symbols and other special symbols placed in fixed positions on the screen. If the display format is random, symbols and possibly lines may be positioned anywhere on the screen. Figure 15 shows such a display. The map shown is composed of 197 straight line segments. There are individual symbols and groups of symbols on the same display, some of which have been written using a typewriter format.

(a) Deflection System. The deflection system for a display cathode-ray tube may make use of electromagnetic deflection coils,

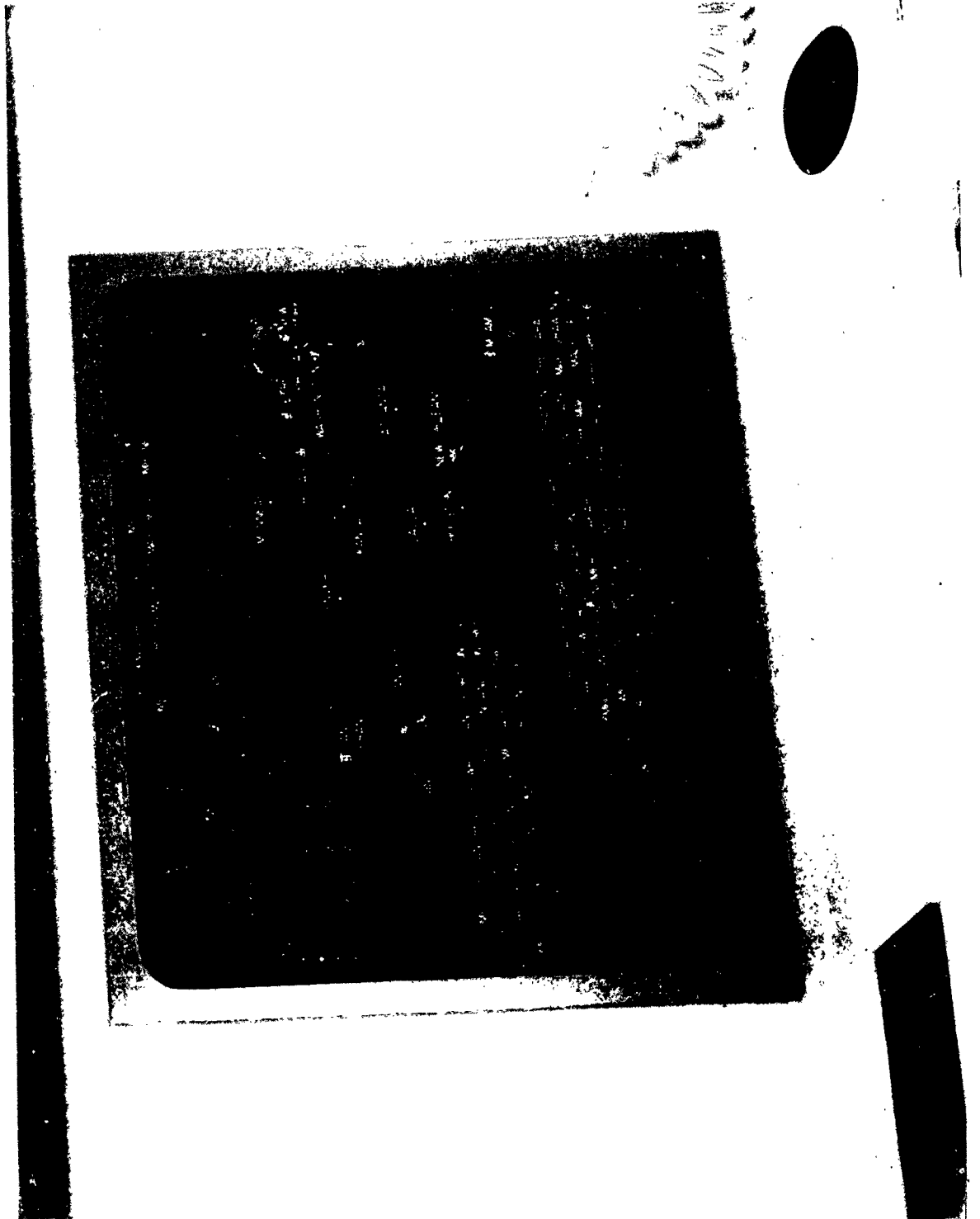

Figure 15. Electronic Display

electrostatic deflection plates, or a combination of both of these. Electrostatic deflection is not good for deflecting an electron beam over wide areas of the screen because it defocuses the beam and causes distortion at high deflection angles. If an electromagnetic deflection system is used for this purpose, however, high frequency response cannot be expected from it because of the high inductions and low self-resonant frequency of the deflection yoke. The two types of deflections are, therefore, often combined in one cathode-ray tube to produce what is referred to as a "woofer-tweeter" deflection system. The electromagnetic deflection system handles the gross positioning on the screen. The electrostatic deflection system does the high-frequency, low-amplitude deflecting necessary to generate symbols on the screen. The same effect is sometimes accomplished by using a dual magnetic deflection system with a tweeter coil made up of only a few turns to achieve minimum inductance.

(b) Symbol Generators. Symbols may be generated on the display screen by one of a number of techniques. The simplest of these is the dot matrix. Symbols are constructed by selecting dots in a 5 x 7 matrix in a manner similar to that used on score boards, and time and temperature signs on banks. A variation on this, available in a commercial symbol generator, permits up to 16 dots to be positioned anywhere within a rectangle to a higher resolution than a conventional 5 x 7 matrix. Figure 16 shows a section of text on a console display screen using this type of symbol generator. The vertical and horizontal positioning resolution, in this case, is one part in 16.

Symbols may also be generated by composing them from a series of strokes. These strokes are frequently constrained to connect points in a fixed matrix. A 3 x 5 matrix is usually sufficient for an alphanumeric symbol font. Such symbols can have curved strokes, however, by deflecting the beam from one point in the matrix to a second point, and then commanding it to go to a third point before it reaches the second point. By purposely limiting the frequency response of the amplifiers, the beam will follow a curved path as it changes course.

In making a calligraphic symbol generator, one traces over a symbol while noting how his pencil moves in X and Y as a function of time. A Fourier analysis is then made of these X and Y functions of

THIS IS A PHOTOGRAPH OF PART OF  
A TRW-80 DISPLAY SCREEN SHOWING  
AN EXAMPLE OF A FONT OF SYMBOLS  
AVAILABLE. 61 ARE SHOWN. THE  
OTHER 3 CODES ARE USED TO CRE-  
ATE BLANK AND SPECIAL FUNCTIONS  
ABCDEFGHIJKLMN OPQRSTUVWXYZ .? :  
0123456789 = + - \* < ( ) Δ Σ # % ° / | ↓ \* \_

Figure 16. Alphanumeric Display

time. The symbol generator produces a fundamental frequency and six or seven of their harmonics as well as their quadratures. These sinusoidal and cosinusoidal voltages are then added in ratios determined by the Fourier analysis to produce horizontal and vertical deflection signals.

A raster type symbol generator generates a small rectangular raster on the display screen for each symbol to be produced. The raster is blanked and unblanked at the appropriate points to produce a symbol on the screen. The video blanking signal may be obtained from one of a number of sources. One commercial unit uses a core memory to produce it. One other commercial unit uses a monoscope tube to determine the unblanking.

A final method of producing symbols on the display screen uses a nonstandard CRT. The electron beam is shaped by passing it through a stencil in the neck of the CRT. This shaped beam is then deflected to the appropriate screen position where a symbol the shape of the hole in the stencil is produced. One of 64 symbols in the stencil plate is selected by electrostatically deflecting the beam through the proper one. The beam is deflected back to the center of the neck and then electromagnetically deflected to the desired position on the screen.

(c) Line Drawing. Figure 17 is a photograph of a CRT with a map constructed of straight line segments displayed on it. The problem of drawing a straight line segment between any two random points appears deceptively simple. It is required that the X and Y deflection systems have identical response regardless of the relative amplitudes of step functions appearing on their inputs. Identical response implies that each of them must have gone the same percentage of the way from its initial value to its final value at any given time. It is also preferable that this response be a linear ramp, not an exponential decay. It is also necessary that the beam intensity be proportional to the velocity at which the beam is being moved on the face of the CRT so that the intensity of all lines, no matter how long they may be, will appear similar.

One solution to the first of these problems is to direct the voltage which represents X or Y position into one end of a delay line having multiple taps. When a step change in either direction occurs in the input voltage, the same step change will appear at each of the taps, but at



Figure 17. Graphical Display

successively later times. The voltages on these taps can then be summed. The output of the summing amplifier is a staircase rising from the old value of voltage to the new value in a fixed time. If the summing amplifier frequency response is purposely limited, the staircase can be smoothed to a reasonably good ramp function.

To solve the problem of intensity regulation, one can take the derivative of the X and Y ramp functions, use the absolute value of this derivative, and choose whichever of these absolute values is greater. The result is within 15 percent of being proportional to the beam velocity on the screen. Each of the operations described can be performed at the necessary speeds by standard circuits borrowed from the analog computer art.

(d) Distortion. Since the purpose of the display is to provide information for a man, distortion on the screen need be controlled only to the point of producing a "good looking" display. The CRT must be shielded to prevent hum pickup from deflecting the beam. Because the large window in the front of the screen cannot be shielded, stray fields in the room must be kept to a minimum. Pincushion or barrel distortion can be corrected with special yokes or by placing small magnets at strategic positions around the CRT. Nonlinearity is usually not much of a problem because human beings have a very high tolerance to it. A television set with 10 percent nonlinearity, for instance, is considered to be very good.

(e) Refresh. A display on a conventional CRT must be refreshed to provide an image that appears to be continuous. If it is refreshed at 60 cps, no flicker is discernible to most people. A 45-cps refresh rate is the lowest acceptable when text is to be viewed on the screen over long time periods. A 30-cps refresh rate is satisfactory for short term viewing of text or for graphic displays. Thirty cps flicker is readily apparent to most people and soon becomes irritating if a display consists principally of text. Refresh rates of 15 cps and lower are satisfactory for certain applications where the data is principally graphical. Human tolerance to flicker increases as the ambient light level is decreased. If the console is to be operated in a darkened room, a somewhat lower refresh rate can be used.

One might think that a long persistence phosphor on the cathode-ray tube screen would allow a very low refresh rate. This is not true because conventional phosphors release a high peak of light energy when they are excited by the electron beam. This is called fluorescence. After the electron beam has left the particular point on the phosphor, it continues to glow at a much lower level for a period determined by its decay time. This is called phosphorescence. At refresh rates greater than 1 or 2 cps, the human eye does not recover sufficiently from the high peaks of fluorescence to even be able to see the phosphorescence. A short persistence phosphor is thus preferable because no ghosts remain when the display is changed.

(f) Color. A white, or nearly white, phosphor is most commonly used on the face of the display screen. Present color CRT's such as those used in color TV sets, do not have sufficient resolution for most display purposes. They are also very sensitive to magnetic fields and other conditions found in military environments.

(g) Contrast. Aluminized screens, similar to those used in TV sets, are commonly used to improve the contrast of the display screen. A circularly polarized mask is sometimes placed in front of the display screen to help to eliminate the ambient light which is reflected by the face of the CRT.

## 2. Memory Cathode-Ray Tubes

The most commonly used memory CRT's have a memory screen near the face plate. The writing gun in the tube causes a static-charged pattern to be created on this memory screen. A flood gun then floods the entire memory screen with electrons, but the memory screen allows them to pass through only where positive charges have been set up on it. The phosphor glows where the electrons pass through the memory screen. The charge patterns on the memory screen can be selectively erased by careful control of the voltages and currents of the writing gun. It is obviously unnecessary to refresh the display on a memory tube, so a buffer memory is frequently not needed. Some memory tubes use the beam shaping principle described in the previous paragraph. The stencils are placed in front of the writing gun and their images are produced on the memory screen. Memory tubes of this type have

several disadvantages. They are considerably more expensive than conventional CRT's, especially when one considers the highly regulated power supplies required for them. They provide a relatively low contrast display. A given tube type is usually available only from a single source.

A dark trace memory tube can be used for display console applications. It contains a P10 phosphor which is normally white, but which turns a dark purple when it is excited by an electron beam. At room temperature its persistence is measured in weeks. When raised to an elevated temperature it quickly fades back to white. It is capable of very high resolution. Since it admits no light at all, but instead must be illuminated to be seen, it is ideal for use under high ambient light conditions. A dark trace CRT is very difficult to make in the large sizes generally required in modern displays. A given type of dark trace CRT is usually available from only a single source. The time required to erase, usually 10 to 15 seconds, is frequently another disadvantage.

### 3. Projection Displays

Console displays can be produced by projecting an image onto a small screen in the console. The techniques used are identical to those described previously, except that a smaller screen and usually a smaller lamp are used. Projection displays in a console should be considered whenever full color dynamic data or map backgrounds are desired.

### 4. Message Indicators

A message indicator is a device which allows one of a number of messages to be displayed on a small screen. The number of messages from which the one may be selected typically varies between 12 and 25 in commercial units. The screen is typically between 1" square and 3" square.

One type of message indicator uses a separate small bulb for each message. A small film containing the image of a message is placed in front of the light bulb and a lens is used to focus that image onto the screen. One of the bulbs is turned on to select its message

for presentation on the screen. More than one message may be superimposed by this type of display.

Lenticular displays use a principle similar to that employed in some children's greeting cards. A plastic piece on these cards produces a different image as it is viewed from different angles. In lenticular displays, light reaching the screen from different angles from the rear causes different images to be created. Bulbs placed at various angles to the display screen can be selectively turned on to produce one of the images.

Another type of message indicator has a series of thin plates, each having a checkerboard pattern of very small holes. When these plates are properly lined up and a light placed behind them, a checkerboard pattern of light passes through them to the display screen. If one of the plates is moved slightly, its checkerboard pattern is out of phase with the others, and it can block light from reaching the screen. By engraving an image on each of the plates in addition to the checkerboard pattern, that plate will produce its image on the screen when displaced.

Another type of message indicator uses a rotating wheel, drum, or belt. The various messages are engraved on the wheel which is rotated to place one of them before a viewing window. Some of these devices have a light inside a translucent wheel or belt.

Thirty-five small disks, arranged in a 5 x 7 matrix, are employed in one type of message indicator. These disks are painted white on one side and black on the other. They are suspended on nylon thread so they are free to rotate, exposing either the black or white side. A permanent magnet is attached to each of the disks and the poles of a stationary electromagnet are arranged to be near the poles of the permanent magnet on the disk. When the electromagnet is magnetized in one direction, the white side of the disk shows and when its magnetism is reversed, the disk turns over to show its black side. By magnetizing the electromagnets in the appropriate pattern, individual symbols can be displayed on these indicators.

## 5. Lights

Most display consoles contain some lights to indicate conditions within the system. These lights may be alone or may be combined into controls. They are available in many shapes, sizes, and colors. Split screens allow portions of an indicator to be illuminated independently. Many of these indicators have labels which are either individually changeable or changeable in groups through change of the movable plastic overlays. It is usually desirable in a display console to label most of the indicators in English rather than to code them with numbers which must be memorized or looked up.

### b. State-of-the-Art Controls (Inputs from Man)

#### 1. Keys

Keyboards usually provide the principal means for communication from the man to the machine in a display console. The functions of all controls should be labeled in English. If the function of a control changes, its labeling should be changed also. It is frequently useful and more efficient to arrange the controls functionally on the control panel. For example, if four keys are to be used to move something up, down, left or right, it is desirable to have these four keys arranged in a diamond pattern. In general, most human factor requirements can be satisfied with commercially available keys. Many keys contain lights or message indicators as an integral part of their assembly.

If a console is to be used for various functions, it is sometimes useful to relabel a group of keys for each of those functions. Figure 18 shows a method of labeling a keyboard developed at TRW. A plastic overlay carries the labels for each of the keys. The keys protrude through the overlay. The overlay contains coding along its top edge in the form of small buttons which actuate switches built into the keyboard. When the overlay is in place and a button is pressed on the keyboard, binary identification of the overlay as well as of the key pressed is sent to the computer. Thus, different programs can be called into the computer by simply placing a plastic overlay on the keyboard with appropriate labels for the keys.



Figure 18. Individual Display Console Overlay

## 2. Cursors

The cursor may be a cross on the screen which indicates a position or it may be a circle, perhaps with a variable radius, which indicates a screen area. There are three basic types of controls which can provide an operator with means for moving the cursor. A velocity control, typically a joystick, moves the cursor in X and/or Y with a velocity which is proportional to joystick position. A position control moves the cursor in X and/or Y a distance proportional to the distance the control is moved. A "bowling ball" control, consisting of a sphere suspended with its top protruding through the control panel and free to roll in any direction about its axis, is typical of a position control. A direct manual control, such as a light gun, can be used to optically trap the cursor on the screen and pull it to some position. Each type of control has advantages in certain situations, and a choice is usually based upon a compromise between convenience, positioning accuracy, and speed of operation.

## 3. Light Gun

A light gun is used to indicate objects which are being displayed on the display screen to the computer. This can be contrasted to the cursor which indicates positions on the screen but not necessarily objects being displayed. A light gun usually contains a photocell which detects the scintillation of a portion of a pattern being refreshed on the display screen. Since the various portions of the display are created sequentially, a timer or counter can indicate to the machine the portion of the pattern at which the light is being aimed. Aiming of the light gun can be facilitated by having it project a circle of light onto the screen or by causing the portion of the display at which it is pointed to blink.

### c. State-of-the-Art Digital Section

#### 1. Buffer Memory

The CRT in most display consoles must have the information written on it many times per second to give the appearance of a continuous display. If the computer is required to provide the information repeatedly, it has very little time to do other things. Typical data rates to a CRT display are between 10,000 and 100,000 bits per second. In

some cases, where a single computer and one man make up the entire working system, the computer has nothing else to do anyway when the man is deciding what to do next and the previous display is obsolete as soon as he has commanded another computation. A separate buffer is not needed here. In most large-scale systems, however, the computer is time-shared between many jobs and its time is too expensive to be used to refresh the displays.

A rotating memory, such as a magnetic drum or disk, is well suited for refreshing a display. In typical rotating memories, information passes under the read heads at just about the right information rate and frame rate for a display. Core memories, while still somewhat more expensive than rotating memories, have certain advantages over them. Their cost is decreasing more rapidly than that of rotating memories. When refreshing the display, they can simulate a rotating memory. When transferring information to or from the computer, the random access and asynchronous operation is also useful. For instance, when a symbol is to be positioned a long distance from the previous one, more time is required to slue the electron beam to the new position than if it were close to the previous one. A core memory can provide information with a syncopated rhythm. Since a drum cannot, the maximum time must be allowed in all cases and much time is wasted. When the console must meet military specifications, it is frequently easier to do so with a core memory both from a size and a ruggedness standpoint.

Provision for allowing information to be transferred from the computer to the memory must be provided. It is usually useful to provide for transferring information from the console memory to the computer so that it is not necessary for the computer to keep a memory record of the display contents while it is doing unrelated things.

## 2. Off Line Message Composition

When an operator generates information to be acted upon by a computer, it is necessary that the information be shown to him for verification before the computer is allowed to act upon it. If he is entering words or numbers, it is best from a human factors standpoint if they appear symbol by symbol as he enters them. He should also be given the ability to correct mistakes he has made and to edit information

that may have changed since it was originally composed. If the computer is required to perform these message composing functions, expensive programming and memory space are required and computer operating time is lost by the interruptions as each character is entered.

If message composing logic is added to the buffer in the display console, information can be entered into the buffer and verified by the operator as it is presented without interrupting the computer. When he has corrected it, if necessary, and is satisfied that the information is complete and correct, he can send the entire message to the computer in one block for immediate action.

Display consoles are frequently used in situations in which forms with blanks in them are presented to the operator. He then fills in the blanks and sends the completed message to the computer. An example of such a message is shown in Figure 19. The marker character to indicate where the next symbol will be entered and the underline to indicate the space he is to fill in are useful to the operator.

It is possible to compose graphical messages such as maps, graphs, or outlines of areas in a console off-line from the computer. The cursor, its controls, and the light gun are usually used for such purposes.

### 3. Computer Interface

Since consoles act as translators between computers and men, it is just as important that they interface smoothly with the computer as with the man. Transferring information to and from the computer is conceptually quite simple. The computer has already been designed to communicate with other pieces of peripheral equipment so the console can act like one of those equipments at the other end of the input/output lines. Most computers are capable of communicating with multiple magnetic tape units and most magnetic tape units operate at a convenient data rate for console input/output, so consoles are frequently designed to simulate magnetic tape units. An interrupt line from the console to the computer is usually desirable to alert the computer when information is ready for it.

1

THIS IS A PHOTOGRAPH OF PART OF  
A TRW-80 DISPLAY SCREEN SHOWING  
TEXT AS THE CONSOLE OPERATOR  
SEES IT. HE MAY FILL IN **+**  
WHERE A CURSOR (THE ARROW) AP-  
PEARS. THIS SEQUENCE INDICATES  
THE OPERATION AS HE DEPRESSES  
SUCCESSIVE ALPHANUMERIC KEYS.

2

THIS IS A PHOTOGRAPH OF PART OF  
A TRW-80 DISPLAY SCREEN SHOWING  
TEXT AS THE CONSOLE OPERATOR  
SEES IT. HE MAY FILL IN **B+**  
WHERE A CURSOR (THE ARROW) AP-  
PEARS. THIS SEQUENCE INDICATES  
THE OPERATION AS HE DEPRESSES  
SUCCESSIVE ALPHANUMERIC KEYS.

3

THIS IS A PHOTOGRAPH OF PART OF  
A TRW-80 DISPLAY SCREEN SHOWING  
TEXT AS THE CONSOLE OPERATOR  
SEES IT. HE MAY FILL IN **BL+**  
WHERE A CURSOR (THE ARROW) AP-  
PEARS. THIS SEQUENCE INDICATES  
THE OPERATION AS HE DEPRESSES  
SUCCESSIVE ALPHANUMERIC KEYS.

4

THIS IS A PHOTOGRAPH OF PART OF  
A TRW-80 DISPLAY SCREEN SHOWING  
TEXT AS THE CONSOLE OPERATOR  
SEES IT. HE MAY FILL IN **BLA+**  
WHERE A CURSOR (THE ARROW) AP-  
PEARS. THIS SEQUENCE INDICATES  
THE OPERATION AS HE DEPRESSES  
SUCCESSIVE ALPHANUMERIC KEYS.

5

THIS IS A PHOTOGRAPH OF PART OF  
A TRW-80 DISPLAY SCREEN SHOWING  
TEXT AS THE CONSOLE OPERATOR  
SEES IT. HE MAY FILL IN **BLANK+**  
WHERE A CURSOR (THE ARROW) AP-  
PEARS. THIS SEQUENCE INDICATES  
THE OPERATION AS HE DEPRESSES  
SUCCESSIVE ALPHANUMERIC KEYS.

6

THIS IS A PHOTOGRAPH OF PART OF  
A TRW-80 DISPLAY SCREEN SHOWING  
TEXT AS THE CONSOLE OPERATOR  
SEES IT. HE MAY FILL IN **BLANK**  
WHERE A CURSOR (THE ARROW) AP-  
PEARS. THIS SEQUENCE INDICATES  
THE OPERATION AS HE DEPRESSES  
SUCCESSIVE ALPHANUMERIC KEYS.

7

THIS IS A PHOTOGRAPH OF PART OF  
A TRW-80 DISPLAY SCREEN SHOWING  
TEXT AS THE CONSOLE OPERATOR  
SEES IT. HE MAY FILL IN **BLANKS**  
WHERE A CURSOR (THE ARROW) AP-  
PEARS. THIS SEQUENCE INDICATES  
THE OPERATION AS HE DEPRESSES  
SUCCESSIVE ALPHANUMERIC KEYS.

Figure 19. Message Composing

The difficult part of designing the console-to-computer interface lies in arranging the data to be transferred in a form that is convenient for programming and economical of computer memory space. For example, consider a display screen with a thousand symbols distributed on it more or less randomly. The operator wishes to point out one of the symbols to the computer and command some operation on it. To position a cursor exactly on a symbol is difficult since the positioning resolution is nearly as fine as the screen resolution and it is hard to tell whether or not the cursor is within one unit of the center of a symbol which may not be symmetrically shaped. If the screen coordinates of the cursor are given to the computer, it must compare these coordinates with those of every symbol displayed on the screen and determine which is closest to the cursor or within some given range of the cursor. This is a time consuming process. If, however, a light gun is used to indicate the symbol, it can send to the computer the address in the console buffer where the word that controls the indicated symbol is stored. The computer can immediately retrieve that word and act upon it. This is not an effort to sell light guns for there are situations where the cursor has a great advantage. The intent is to indicate that the console designer should have a thorough understanding of the problems which the console will be used to solve as well as the programming for the computer. It is well worth while to have a programmer review the functional operation of a console before its specifications are frozen. Small changes in the cost of a console (sometimes even downward) frequently save large sums in programming or computer time.

d. Example of an Existing Console

In order to illustrate the basic design principles and performance characteristics of present day consoles, a specific model, the TRW-85, will be described. Completed in 1963, this console represents one generation of a series whose first predecessor was delivered in 1959.

Many of the elements of display consoles were used before 1959. These elements include keyboards and controls of many types, radar and other displays, the CRT plotters available with IBM 700 series computers, and the semi-automatic armament control systems which usually worked with analog computers and radars. None of these,

except perhaps the last one, was a serious attempt to achieve a true two-way communication between a man and a computer in order to integrate them into a working system.

#### 1. TRW-85 Display Console

This console (Figure 20) has a 23-inch cathode-ray tube with a 12- x 16-inch display area. Alphanumeric and graphical information can be combined on the display screen. A font of up to 125 different symbols, each of them in two sizes, is available. The computer can, by setting a bit in the input word, cause any symbols or lines to blink on the screen to call the operator's attention to it. It has an internal magnetic core buffer with a 4096-word,9-bit capacity.

Each of the 25 lights in the group to the left of the display screen is controlled by the computer. These lights are labeled as a group by a plastic overlay film which is inserted between a diffusing plate over the bulbs and a transparent top plate. The overlay keyboards on each side of the control panel can contain 60 lights under program control. These overlay keyboards are functionally similar to those described previously except that they are labeled by a thin plastic film which is placed between a diffusing plate over the bulbs and a top transparent plate. This piece of film has holes punched along the top to code it for identification to the computer. The principal advantage of this new overlay film instead of the thicker plastic overlays is the smaller amount of storage space required for a set of overlays.

The keys in the overlay keyboards are the only ones which communicate with the computer directly. Each of them, when pressed, causes an interrupt signal to be sent to the computer. When the computer commands the keyboard input from the console, 12 bits are sent, 6 of them identifying the key pressed and 6 of them identifying the overlay on the keyboard.

The typewriter keyboard in the center of the control panel is used to compose messages in the console's memory. Functional keys such as carriage return, back space, and shift are used similarly to those on an electric typewriter. The alphanumeric keys enter symbols on the screen where a marker indicates they will be entered as was discussed in connection with Figure 19.

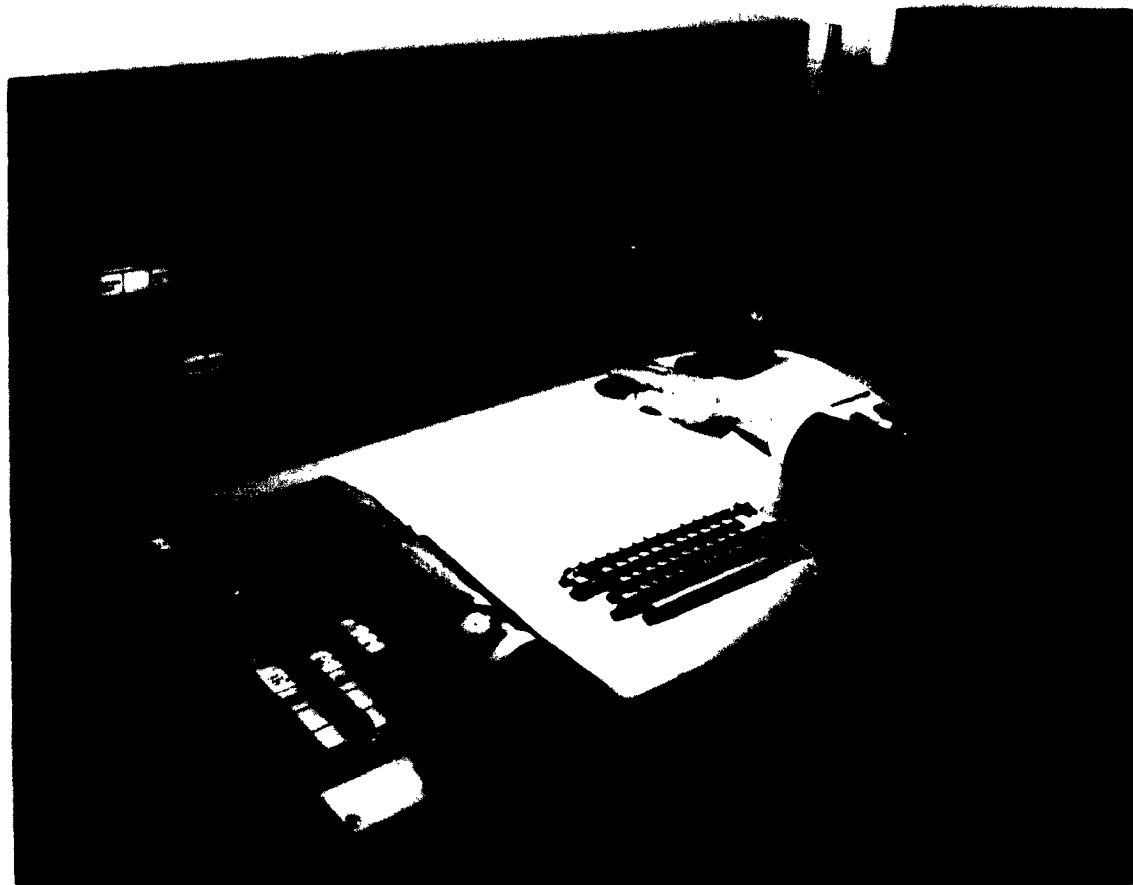

Figure 20. Display Console

The control keyboard at the upper left of the control panel contains the keys that have various internal functions. These keys include those that create the cursor, create the marker symbol on the screen, copy or delete text, create or delete lines, and activate the light gun. A bowling ball type of cursor control and a light gun are available in the console.

Figure 21 shows a block diagram of a display console. The converter block controls the timing of data and synchronizing signals for data flow to and from the computer. It also changes the electrical levels and the data format from that of the computer to the internal console format. Most of the data coming in through the converter flows to the memory, but some of it goes to the static store which is a register-type memory that controls the console lights and some of the keyboard interlocks. The keyboard logic accepts data from the keyboards and sends it to the memory or through the converter to the computer. If the computer commands it to, the converter can read the memory and send the information to the computer. The display logic normally reads through the memory every 22 milliseconds. It digitally prepares the data for the display elements of the console. The dotted line through the center of the figure divides the digital sections of the console from the nondigital control, display, and analog sections. The symbol generator and the deflection and unblinking amplifiers include all of the analog circuitry necessary to create the electronic display. The cursor control and light gun act on the display through the digital section of the console. The cursor coordinates and light gun address are recorded in dedicated locations in the memory so that the computer can read them at any time.

#### e. Advanced Display Techniques

The state of the art of display consoles is advancing at such a rapid rate that it is difficult to look very far into the future. It is also difficult to talk about future techniques under development because some of the more promising ones are still considered proprietary by the companies developing them. It is obvious that the present components of display consoles will be replaced by smaller, faster, less expensive or more reliable ones in the future.

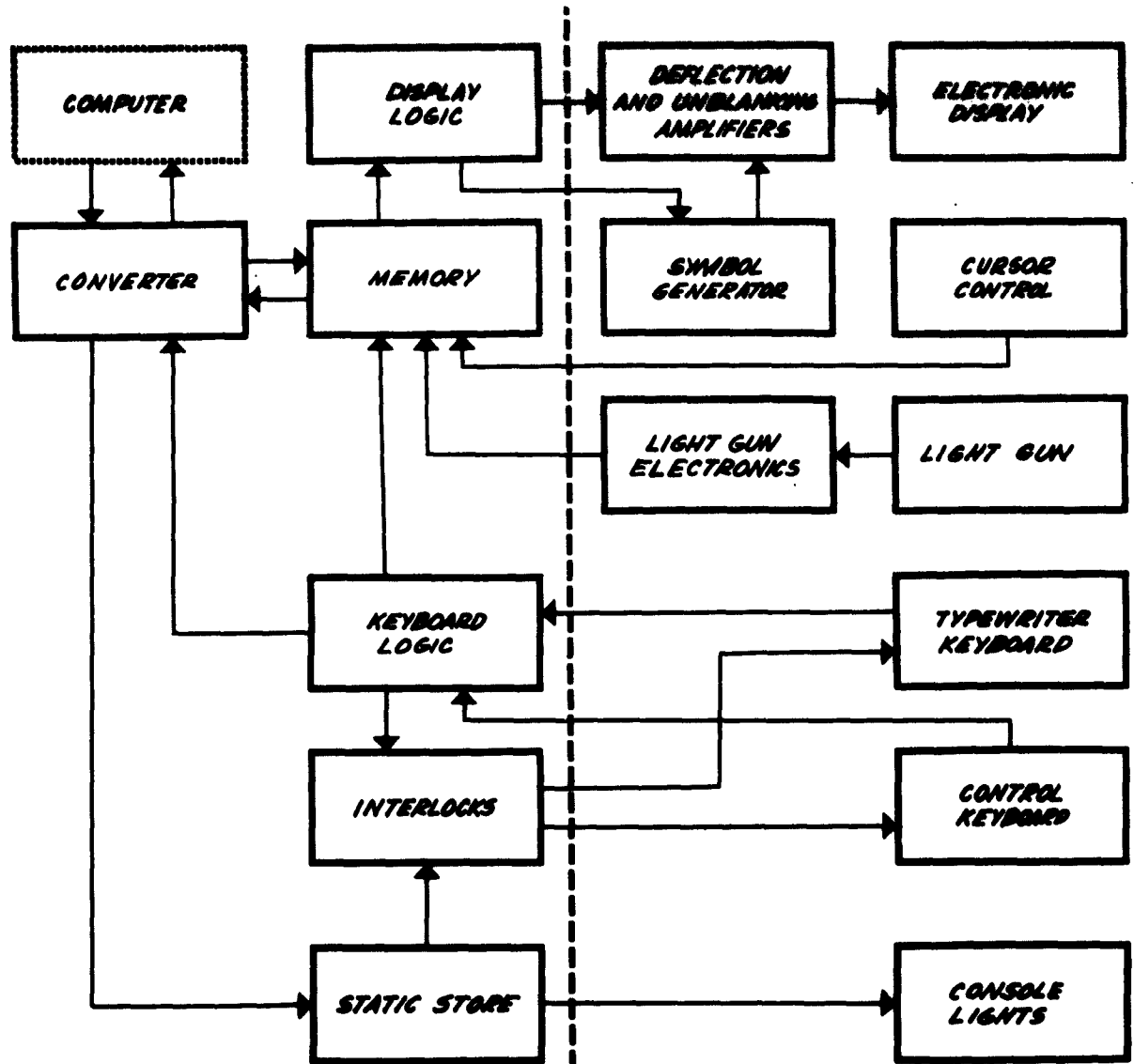

**MODULAR CONSTRUCTION**

**OPTIONAL CONFIGURATIONS AVAILABLE**

- LIGHT GUN, CURSOR OPTIONAL**
- MORE OR FEWER KEYS OR LIGHTS**
- COMPUTER-CONTROLLED SYMBOL SIZE**
- SLAVE DISPLAY**
- 2 TUBE CONSOLE**
- 2 DISPLAYS - 1 TUBE**
- CORE OR DRUM MEMORY**

**CONVERTER CAN BE MATCHED TO MOST COMPUTERS**

Figure 21. Display Console Block Diagram

### 1. Special Phosphors

Several special phosphors for the faces of CRT's have been announced recently. One of these, a transparent phosphor, promises to provide much higher contrast ratios than are now attainable even in very high ambient light situations. Most phosphors are composed of many very small grains. When the electron beam strikes these grains they glow. The light created is internally reflected in the grain, as in a gemstone, and finally leaves it to produce the visible glow. Ambient light getting to the phosphor is similarly reflected internally in the grains and much of it is sent back out toward the observer, producing background light and low contrast. This situation is made worse in the attempt to produce higher resolution phosphors by making the grain size smaller. A transparent phosphor is made by either fusing the phosphor into one large grain covering the entire faceplate or by suspending it in a medium (a glass) having the same index of refraction as the phosphor itself. Since there is no internal reflection of the light emitted by the phosphor, the resolution is limited only by the diameter of the electron beam reaching the phosphor. If the internal face of the transparent phosphor is coated with a black material, such as carbon, ambient light will not be diffused and sent back out the faceplate and the background of the screen will appear jet black to the observer.

Another type of phosphor has been announced which may eliminate the need for rapid refresh rates while not having the disadvantages of memory type tubes. Most phosphors have a bright fluorescence and a much dimmer phosphorescence which decays exponentially from the time the electron beam leaves the point. The newly announced phosphor has a lower peak brightness but continues to glow at nearly the same level for a very long period (up to a few seconds) and then dims abruptly. Phosphors with rectangular emission characteristics such as this may be used with very low refresh rates of about two or three frames per second without producing flicker. Much slower and less expensive selection circuitry and symbol generators could be used with these new phosphors while the response on the screen would still be instantaneous relative to human reaction times.

## 2. Special Cathode-Ray Tubes

It seems inevitable that some manufacturer will develop a good color CRT. A great variety of techniques is being explored and one or more will probably emerge from the laboratories within a few years. Full color displays will add another dimension to consoles and will permit them to transmit information even more efficiently.

The television industry is working on flat picture tubes so TV sets can be made even smaller than they already are. When one is developed display consoles will probably use them for the same reason.

One manufacturer has recently announced a very small (1-inch) CRT with optics which permit it to be placed very close to the eye and appear as a larger tube at a distance. This CRT has been mounted on a headband to hold it along the right side of a man's head. A partially silvered mirror is suspended in front of his eye. When he focuses that eye at a distance of about 10 inches, he sees the image on the CRT. When he focuses beyond that distance, the tube image is out of focus and does not appreciably interfere with his vision. It is obvious that a stereoscopic image could be presented to him if two of these devices were used, one for each eye.

## 3. Electroluminescent Panels

When the brightness and resolution of electroluminescent panels are improved sufficiently, they may replace CRT screens in display consoles. Electroluminescent panels were discussed in Section C. 1. c. 3.

## REFERENCES

1. R. T. Loewe, R. L. Sisson, P. Horowitz, "Computer Generated Displays," Proceedings of the IRE, Vol 49 No. 1, January 1961, pp. 185-195.
2. J. J. Josephs, "A Review of Panel-Type Display Devices," Proceedings of the IRE, Vol 48, August 1960, pp. 138-1395.
3. Arthur S. Kramer, "Cathode-Ray Storage Tubes for Special Purposes," Electronics, 30 January 1959, pp. 52-53.
4. Arthur S. Kramer, "Cathode-Ray Storage Tubes for Direct Viewing," Electronics, 23 January 1959, pp. 40-41.
5. Richard A. Barker, "Techniques of Dynamic Display, Part I: Cathode Ray Tubes," Control Engineering, February 1960, pp. 100-106. "Techniques of Dynamic Display, Part II: Optics at Work," Control Engineering, April 1960, pp. 121-126. "Techniques of Dynamic Display, Part III: From TV Pickup to Matrix Cells," Control Engineering, June 1960, pp. 97-102.
6. "IMCC Systems and Performance Requirements Specifications," WDL-TR-E120, The Philco Corporation, 7 September 1962.
7. "Compendium of Visual Displays," RADC Compendium 61-1, Rome Air Development Center, Griffis AFB, December 1961.
8. "The RW Display and Analysis Console," M250-OU7, Ramo-Wooldridge, Division of TRW Inc., Canoga Park, California, 5 April 1960.

## BIBLIOGRAPHY

1. D. G. Aid, G. H. Balding, and C. Susskind, "Topological Transformations by Electronic Scanning Techniques," IRE Transactions on Instrumentation, Vol I-7, June 1958, pp. 121-125.
2. D. G. Aid, and C. Susskind, "Displaying Integrated Instrumentation," Electronic Industries, Vol 17 No. 7, July 1958, pp. 68-71.
3. G. H. Balding, and C. Susskind, "Generation of Artificial Electronic Displays, with Applications to Integrated Flight Instrumentation," IRE 1960 Convention Record, Part 8, pp. 97-104.
4. M. D. Balkovic, and others, "A Data Communications and Processing System for Cardial Analysis," AFIPS Conference Proceedings, Vol 22, 1962 Fall Joint Computer Conference.
5. Richard A. Barker, "Techniques of Dynamic Display, Part I: Cathode Ray Tubes," Control Engineering, February 1960, pp. 100-106. "Techniques of Dynamic Display, Part II: Optics at Work," Control Engineering, April 1960, pp. 121-126. "Techniques of Dynamic Display, Part III: From TV Pickup to Matrix Cells," Control Engineering, June 1960, pp. 97-102.
6. C. A. Caceres, "How Can the Waveforms of a Clinical Electrocardiogram Be Measured Automatically by a Computer," Meeting of the IRE Professional Group on Bio-Medical Electronics, New York, February 1960.
7. "Compendium of Visual Displays," RADC Compendium 61-1, Rome Air Development Center, Griffiss AFB, December 1961.
8. "3D-Display, Concepts and Requirements," Space/Aeronautics, September 1962, pp. 60-67.
9. "Design Studies for Globular Displays," Battelle Memorial Institute, 7 August 1959.
10. R. P. Devoe, and J. E. Hoagbin, "Problems in Meeting Future Combat Surveillance Display Requirements," University of Michigan, Institute of Science and Technology, June 1961.
11. L. Grumley, and others, "Display Problems in Aerospace Surveillance Systems, Part I," HRB-Singer, Inc., State College, Pa., No. AFESD-TR-61-33, 256-R-2, 30 June 1961.
12. M. D. Havron, and J. P. Jenkins, "Information Requirements Methods as Applied to Development of Displays and Consoles," Human Sciences Research, Inc., HSR-rr-61/4-Sm, March 1961.
13. G. Hellings, "All-Weather TV Display Adds Realism to Simulated Landings," General Precision Systems, Ltd., Control Engineering, February 1963, p. 107.

14. "IMCC Systems and Performance Requirements Specifications," WDL-TR-E120, The Philco Corporation, 7 September 1962.
15. J. J. Josephs, "A Review of Panel-Type Display Devices," Proceedings of the IRE, Vol 48, August 1960, pp. 138-1395.
16. R. K. Jurgen, "Solid State Panels for Display or Storage," Electronics, Vol 32, 30 January 1959, pp. 46-47.
17. H. P. Kallman, and J. Rennert, "Data Storage and Display with Polarized Phosphors," Electronics, Vol 32, 28 August 1959, pp. 39-41.
18. J. E. Karlin, and S. N. Alexander, "Communication Between Man and Machine," Proceedings of the IRE, May 1962, pp. 1124-1125.
19. B. Kazan, "Feedback Light-Amplifier Panel for Picture Storage," Proceedings of the IRE, Vol 47 No. 1, January 1959, pp. 12-19.
20. E. J. Kennedy, and others, "Criteria for Group Display Chains for the 1962-1965 Time Period," Report No. RADG-TDR-62-315, RADG, Griffiss AF Base, New York, July 1962, p. 29.
21. R. C. Kennedy, and F. J. Gaskins, "Electronic Composites in Modern Television," Proceedings of the IRE, November 1958, pp. 1798-1807.
22. Arthur S. Kramer, "Cathode-Ray Storage Tubes for Direct Viewing," Electronics, 23 January 1959, pp. 40-41.
23. Arthur S. Kramer, "Cathode-Ray Storage Tubes for Special Purposes," Electronics, 30 January 1959, pp. 52-53.
24. J. C. R. Licklider, "Man-Computer Symbiosis," IRE Transactions on Human Factors in Electronics, Vol HFE-1, March 1960, pp. 4-11.
25. R. T. Loewe, R. L. Sisson, P. Horowitz, "Computer Generated Displays," Proceedings of the IRE, Vol 49 No. 1, January 1961, pp. 185-195.
26. H. G. McGuire, and T. L. Stoddard, "Information Presentation Systems," Electrical Engineering, Vol 80, February 1961, pp. 111-117.
27. R. B. Nehrich, Jr., and R. K. Logan, "A Color Conversion Technique for Electroluminescent Light," U. S. Navy Electronics Laboratory.
28. F. H. Nicoll, and A. Sussman, "A Two-Color Input, Two-Color Output Intensifier Panel," Proceedings of the IRE, November 1960, pp. 1842-1846.
29. L. W. Paine, and C. A. Steinberg, "A Medical Magnetic Tape Coding and Searching System," IRE Convention Spring 1962.

30. D. W. Perkins, "3-D Display, Spherical Spiral Display," Space/Aeronautics, September 1962, pp. 60-67.
31. Rajchman, et al, "Transfluxor Controlled Electroluminescent Display Panels," Proceedings of the IRE, November 1958, pp. 1808-1824.
32. "A Report Bibliography," ASTIA Document No. AD 265-432, April 1962.
33. A. E. Rikl, and C. A. Caceres, "The Use of Computers of Physicians as a Diagnostic Aid," The New York Academy of Sciences, Ser II, Vol 23 No. 3, 1960, pp. 237-239.
34. "The RW Display and Analysis Console," M250-OU7, Ramo-Wooldridge, Division of TRW Inc., Canoga Park, California, 5 April 1960.
35. E. A. Sack, P. N. Wolfe, and J. A. Asars, "Construction and Performance of an ELF Display System," Proceedings of the IRE, April 1962, 11. 432-441.
36. F. Slack, and A. A. Sandberg, "Tracking and Display of Earth Satellites," No. AFCRC-TR-59-370, USAF Astrosurveillance Sciences Laboratory, Air Force Cambridge Research Center, December 1959.
37. S. L. Smith, "Visual Displays, Large and Small," Mitre Corporation, ESD-TDR-62-338, November 1962.
38. G. Southworth, "Outline Generator for Educational Television," Electronics, Vol 32, April 1959, pp. 52-53.
39. C. A. Steinberg, and C. A. Caceres, "Pattern Recognition in the Clinical Electrocardiogram," Fourth International Conference on Medical Electronics, New York, July 1961.
40. S. Tando, "A Solid State Display Device," Proceedings of the IRE, December 1962, pp. 2445-2451.
41. D. B. Yntema, and W. S. Torgerson, "Man-Computer Cooperation in Decisions Requiring Common Sense," IRE Transactions on Human Factors in Electronics, Vol HFE-2, March 1961, pp. 20-26.

## APPENDIX XXXIII. CONSOLE AND DISPLAY DESIGN FOR THE GLOBAL RANGE

### A. INTRODUCTION

The objectives of this Appendix are: to develop the man-machine communications requirements for the global range; to consider alternative approaches for satisfying the requirements; and to recommend an effective and feasible system design.

The starting point for this phase of the design study is the operational concept, and especially that part relating to the monitor and control functions. Operational concepts for the global range are developed in Section III. V. and will not be detailed here. Of particular significance to the design of system consoles, displays, and the associated generation and distribution system is its dependence on a highly integrated and sophisticated data handling concept. This factor has been largely instrumental in the selection of on-line consoles and computer-driven displays. Conversely, the projected performance and the advantages stemming from incorporation of effective man-machine communications techniques have had significant influence in shaping and refining the monitor and control concepts.

Unnecessary sequential manual handling of any control information would tend to increase both time delays and the possibility of error arising from message garbles. For these reasons the entry of all such data into the system in digital form at the point of origin is regarded as an ultimate design goal.

Associated with the emphasis on group, as well as individual, information presentation needs is a common system for the generation and distribution of display data to the large (group) displays and consoles. The decision to subdivide control information into detail hierarchies, the possibility of integrating the information presented by the displays and consoles, and the ability to avoid ambiguity, indicated additional reasons for a common generation and distribution complex.

One additional design factor, often employed, sometimes overlooked, and seldom mentioned is worthy of consideration. Although a thorough analysis of display and console requirements is absolutely essential to proper design,

usage will certainly be continually influenced by unforeseen mission changes, modification and expansion of the global range, and human ingenuity stimulated by operational experience. The system is a tool; it must be capable of expansion, modification, and adaptation at reasonable cost and with minimum disruption of range support activities.

## B. RANGE CONTROL CENTER REQUIREMENTS

The display and console requirements are based on the operations concepts for the Local Range Control Center (LRCC) and the Global Range Control Center (GRCC) evolved in Subsection V. of Section III of this report. The objective is to establish the basic needs of the operating personnel in order that optimum man-machine techniques can be selected.

First consideration is given to the local range control center which encompasses nearly all command and control functions within the global range for missions supported only by the facilities within its jurisdiction. Attention is then directed to the global range control center. It will be seen that requirements at the two control center echelons are the same in most respects, differing only in the detail level of the operations plan and schedule. Many of the procedures, techniques and equipments applicable to the local range control center carry over to the global range control center.

### 1. LRCC CONSOLE FUNCTIONS AND DESIGN OBJECTIVES

The system consoles are the working stations for LRCC personnel. Their principal function is to provide a suitable interface between the data processing complex and the operators. This section outlines the primary individual console functions.

#### a. Report Reception and Review

In the ultimate system configuration, the majority of status and progress report data will be converted into digital form at the point of origin. These data, after transmission and reception, will be converted from the coded form into readily comprehensible formats incorporating letters, symbols and numbers. They are then presented to the cognizant operator directly on his console. Depending upon the nature of the data, and especially the operational penalty incurred by time delays, it will be

reviewed either before or after consolidation for presentation in the group displays. In some instances, the latest status or progress information may be displayed to the operator, together with background information, such as the last reported status pertaining to the same range facilities and the time of the last reporting.

b. Data Entry

In some cases the console and operator may constitute the point of origin for digital data entry where verbal or other means have been employed for its conveyance. Such data will be entered into a predesigned format, allowing immediate display of the entered data, and permitting immediate review and confirmation on the part of the operator before entry into the computer memory.

c. Large (Group) Display Control

A primary function of the individual consoles is the control of the large (group) displays. Such control may consist only of inserting correct quantitative information into the large display formats. Because of the possible confusion arising from the insertion of incorrect data, the format will be duplicated at the responsible individual's console so that the entry can be made, seen there, and confirmed before the large display is correspondingly changed. Certain of the large displays will have changeable formats which will be under the direct control of the assigned console positions.

d. Schedule Presentation

In addition to the operations plan and schedule, available to all personnel working in the same general area, there will be more detailed schedules presented to the individual console operators. The specific nature of the schedule display will depend upon the responsibility of the operator. In its simplest form it will consist of the next event in which the operator has interest, and the time until this event is to occur. In the more complex form, the schedule may consist of a number of events, scheduled times of occurrence, and the interrelationships between such events.

e. Action Demand

Action demands may originate on a scheduled or an unscheduled basis. Thus, an operator who is responsible for taking some action, perhaps making a decision, at some point in the schedule may be presented with an unambiguous indication of the action to be taken, and a response time, that is, the lapse of time permitted for him to take the action.

In emergency situations, such as the loss of a communications link for which no backup is available, the operator may simply be presented with the bare essentials of the emergency and the demand to take action. If this form of emergency has been anticipated, a number of contingency actions for his selection may also be presented.

f. Decision Entry, Review, and Confirmation

Operator-action-demand decisions must be entered through the controls on the console. To minimize operator error, it will normally be required that the entry be made, reviewed by him, and confirmed before it is executed. In order to minimize time lag occasioned by action demand and decision entry, provisions will be made for a priori decisions, where the need for such decisions can be anticipated. Thus the impending failure of a particular piece of instrumentation equipment may be ascertained through periodic review of the quality of data obtained. The operator may decide to switch over to an available alternate even before the computer program presents him with an action demand. He may then either choose to switch over and cause it to be executed, or make the decision, and wait for the action demand before it is executed.

g. Special Request

One of the most powerful arguments for the versatile form of display is the availability of details on a selective basis. The range facilities control console can request the same form of status information which is normally seen only at the instrumentation control console. Such a request might be coordinated between these two stations in order that both operators see the same data, and the proper decisions be made cooperatively.

h. Special Data Presentation

Not all data which may be requested are suitable for presentation in the schedule, and other tabular formats normally employed in this system. Graphical forms, charts, and the many other applicable modes for presentation should also be considered.

i. Interior Communications

Interior communications (Intercom) controls available to the operator are independent of the digital communications referred to above. Included are verbal communications controls linking stations within the control center, and voice communications controls linking remote stations.

**2. LRCC LARGE (GROUP) DISPLAY FUNCTIONS  
AND DESIGN OBJECTIVES**

As discussed in Section B. 4. of Appendix XXXII, a group display is intended for simultaneous viewing. Three primary factors are particularly significant in the selection and design of the group displays for the LRCC.

- Functions and organization
- Information flow patterns
- Facility layout

The first two factors are discussed in Subsection V. of Section III; the recommended layout plan is discussed in the following paragraphs.

The large (group) display consoles complement individual consoles by providing information of common interest to several related functional areas. Such information will be of a general nature, to provide both an overview of the situations, and an orientation for the operators who may be viewing detailed information of restricted scope using individual consoles.

This present section includes the nature of the information to be presented using the large displays, the required accessibility to the working groups in the several functional areas, and the logical layout for the main operations area.

## a. Main Operations Area

The main operations area is designed to contain those teams of operating personnel who interact most closely on a continuing basis, to monitor and control-range operations. Figure 1 contains the functional subdivisions of the main operations area, vehicle safety and surveillance area superimposed upon the control-data-flow diagram.

### 1. Layout Plan

Figures 2 and 3 illustrate an effective layout and location of the functional area teams within the main operations area. Two fundamental ground rules have been applied in establishing the physical configuration of personnel within the main operations area:

- Personnel with related duties are placed in close proximity.
- Personnel are located so as to have proper access to displayed information affecting implementation of their assigned responsibilities.

### 2. Display Classes and Accessibility

Table I includes a summary of the data accessibility requirements for the functional area team members within the local range control center. Although it also tabulates the individual display console requirements and considers both the displays and the personnel in the other areas, only the main operations area is of immediate concern. The three display classes listed in Table I will be described in detail in the next section.

(a) Range Status/Progress Summary. This display will provide the least detail and the broadest scope of activities for use in the main operations area (see Figure 4). It consists of two parts: (1) a map background display, including location of range ships and other mobile elements; status of all stations, communications links; superimposed signaling of impending mission involvements, launchings; station coverage, clearance boundaries, and other area designations selectively, and as required; and subtrajectory tracks; and (2) a chart presentation, including a time phased schedule of all major mission involvement milestones; an identification of separate test missions; and a highlight of potential conflicts.

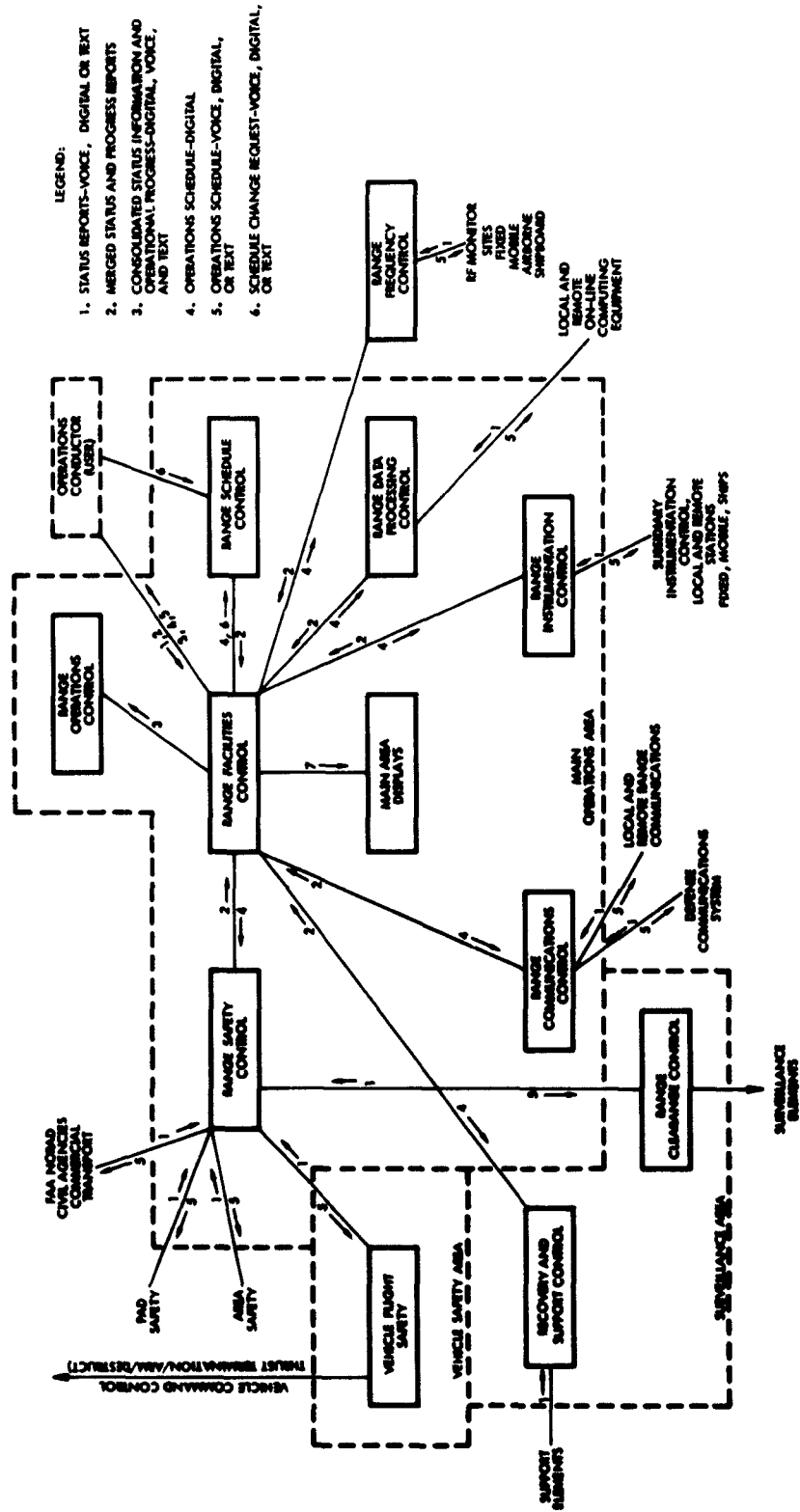

Figure 1. Local Range Control Center Functional Subdivisions and Control Data Flow

LEGEND

1. RANGE SAFETY CONTROL
2. RANGE INSTRUMENTATION CONTROL
3. DATA PROCESSING CONTROL
4. RANGE COMMUNICATION CONTROL
5. RANGE FACILITIES CONTROL
6. RANGE SCHEDULE CONTROL
7. RANGE OPERATIONS

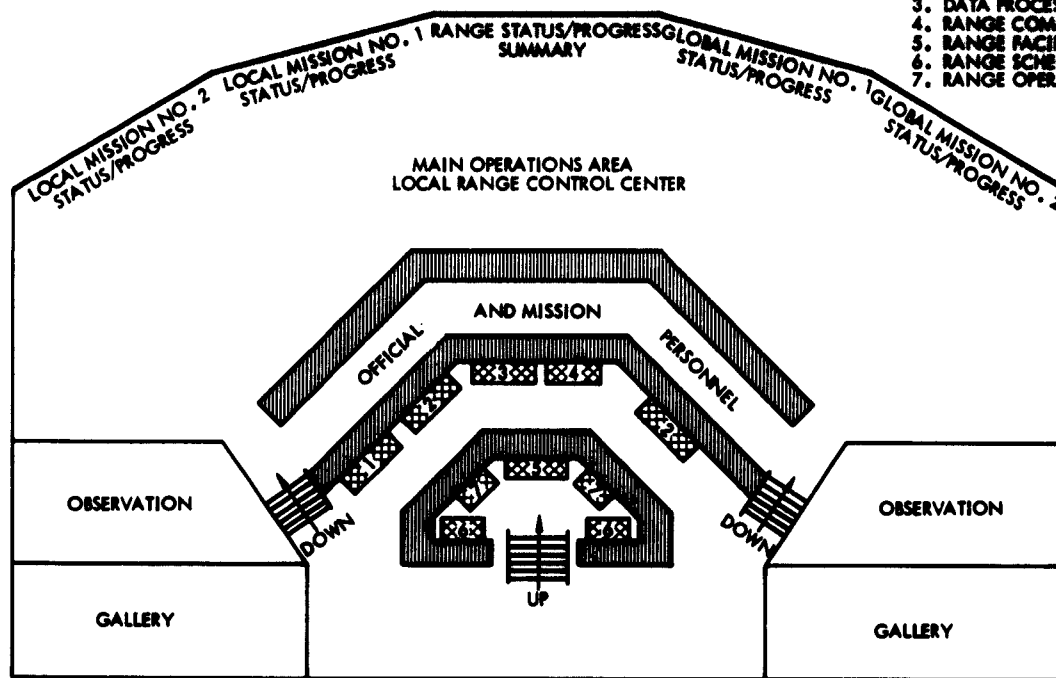

Figure 2. Main Operations Area, Local Range Control Center

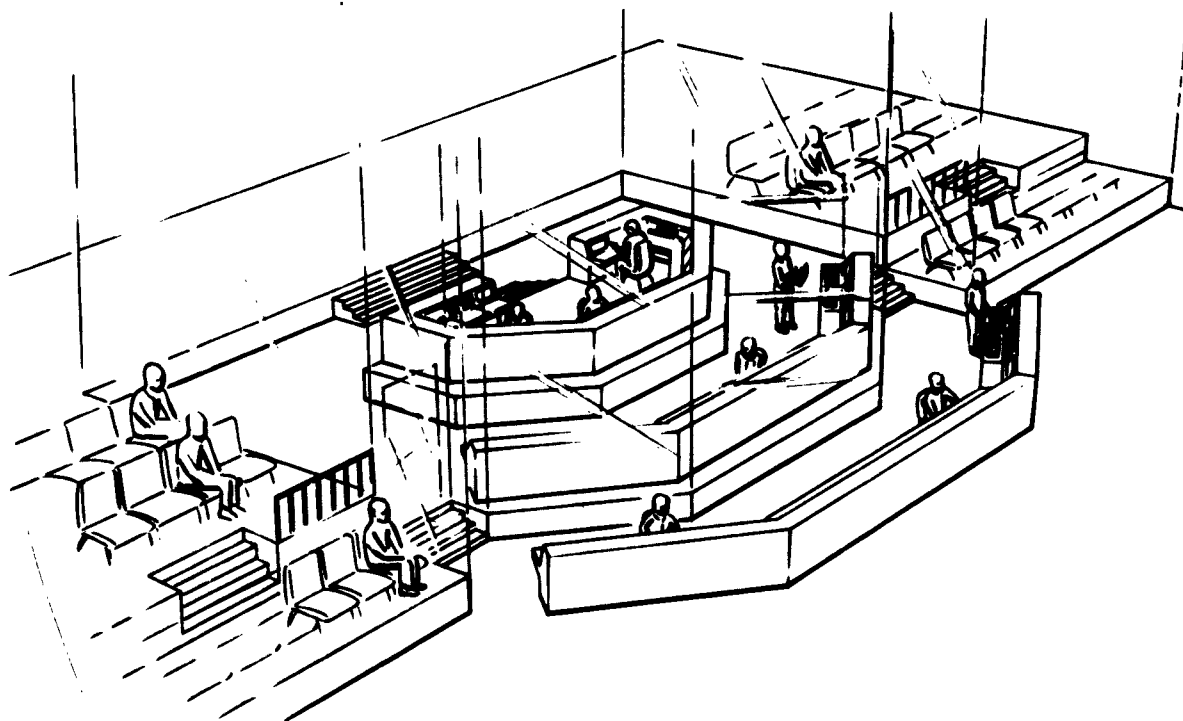

Figure 3. Perspective Sketch - Main Operations Area, Local Range Control Center

Table I. Local Range Control Center Display and Console Requirements

DISPLAY CLASSES	Range Planning	Range Operations Control	Range Schedule Control	Range Facilities Control	Range Instrumentation Control	Range Communications Control	Range Data Processing Control	Range Safety Control	Range Frequency Control	Recovery & Support Control	Range Clearance Control	Vehicle Flight Safety Control	Emergency & Disaster Ops.	Weather Central	Total Number
Range Status/ Progress Summary	x	x	x	x	x	x	x	x							1
Mission Status/ Progress	x	x		x	x	x	x	x							4
Range Schedules		x	x	x											1
<b>BASIC CONSOLES</b>		2	2	2	4	2	2	2	1	1	1	1			21
Vehicle Safety Display Complex		R						R				x			1
Surveillance Area Displays		R		R				R		x	x		R		1
Weather Display		R		R				R		R			R	x	1

R = Remote

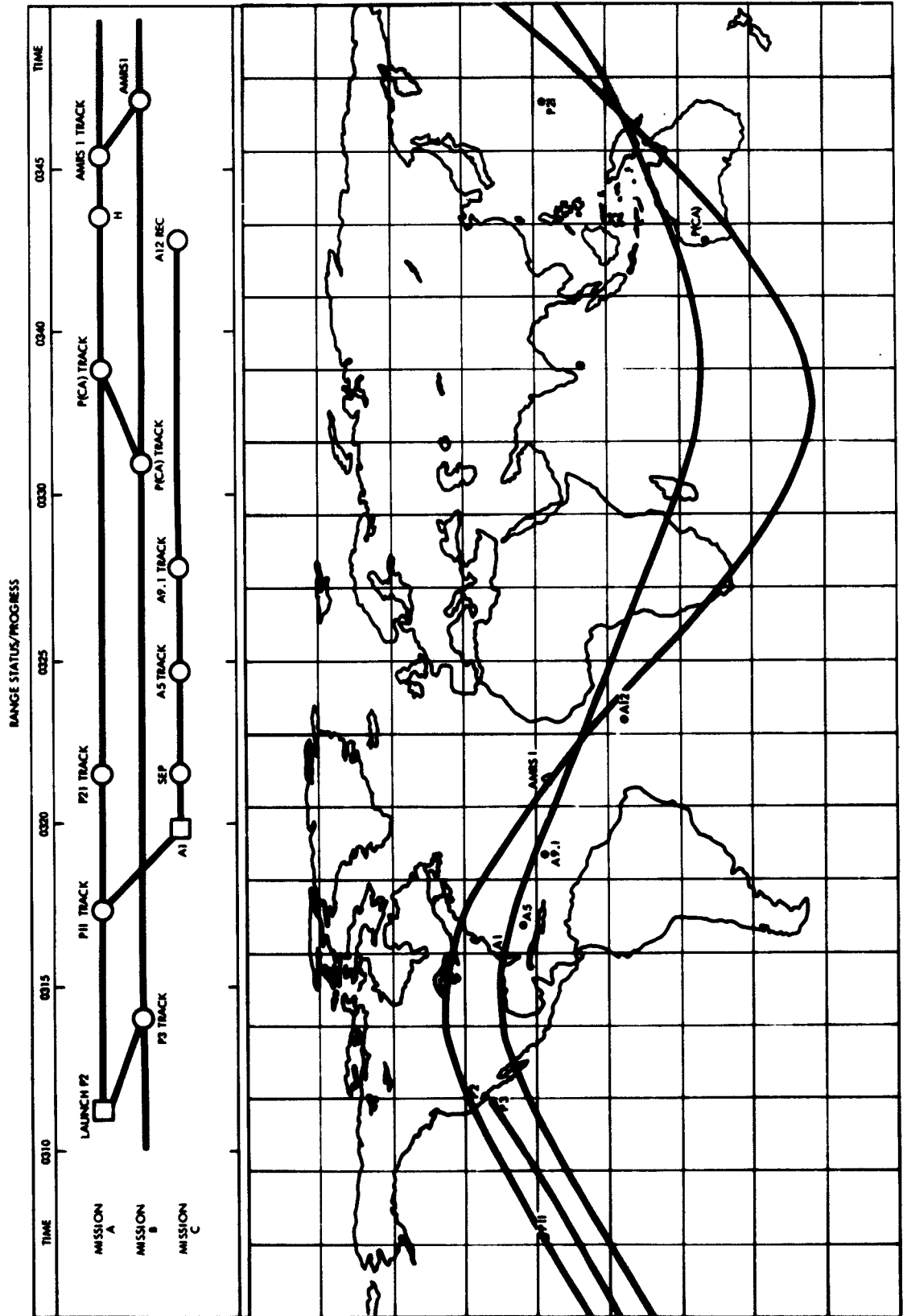

Figure 4. Range Status Progress Display

(b) Mission Status/Progress. This display (there will be one for each local or global mission in progress) will be a combination tabular and chart presentation. The following information will be shown.

- Medium tabular status and performance detail
- Identification of facilities involved
- Indication of potential conflicts.

Figure 5 is an artist's concept of this display.

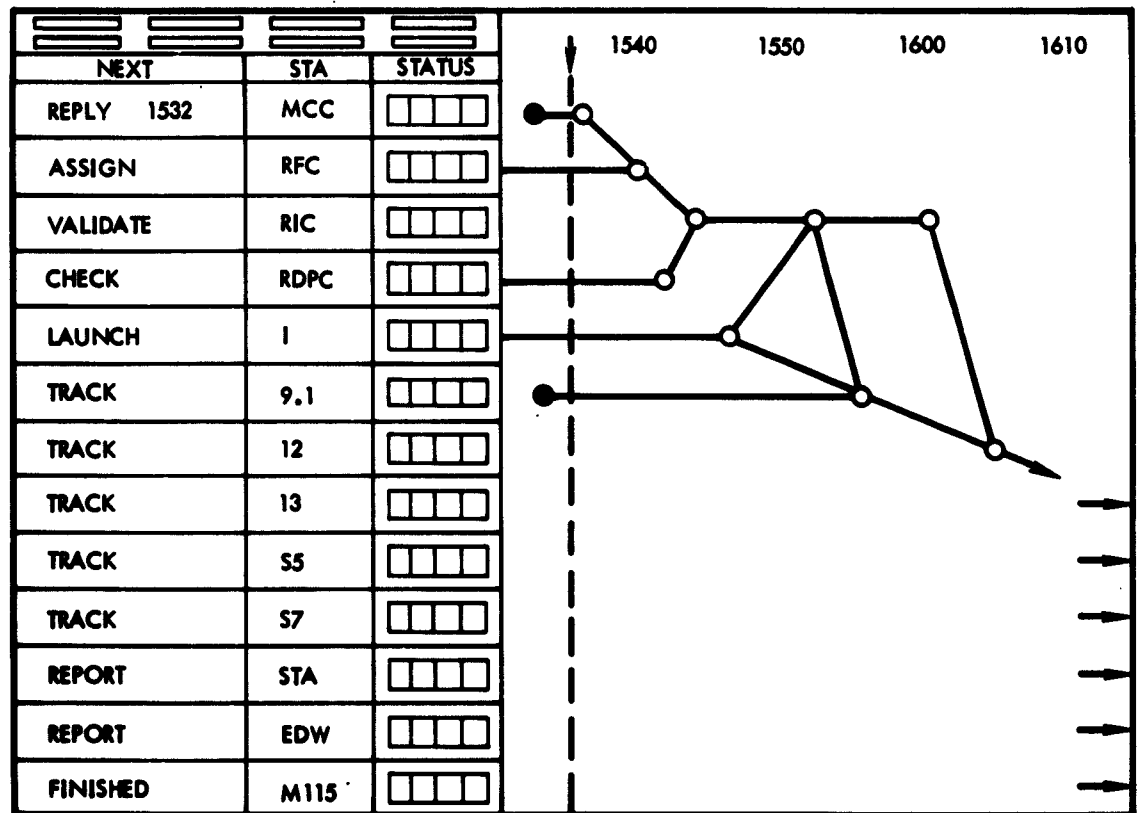

Figure 5. Mission Status Progress Display

(c) Range Schedules. This display is used primarily by range schedule control in determining suitable modifications to the operations plan and schedule, in response to schedule request changes. Unlike the other large displays, it need be accessible only to a limited number of personnel as indicated in Table I. This display is characterized as follows:

- Variable format - under control of range schedule control

- Main format - schedule with facilities support keyed to planned missions
- Secondary format - operations events diagram with selectable time scale, detail, and test missions.

### 3. Format Considerations

In the information categories that are directed toward group usage, the primary types of information formats utilized are:

- Fixed format - tabular
- Variable format - tabular
- Fixed format - pictorial
- Variable format - pictorial

The division of the formats into tabular and pictorial, and then fixed and variable, is based on the format effect on the implementation technique. The amount of variable information, along with general configuration, not only defines the display but limits the techniques applicable. For example: if single character update is required in less than one second, then the present film generation and display techniques could not be used, since all information must be regenerated for one change, and the response time cannot be achieved. But if the requirements dictate extensive character annotation changes plus changes in high-resolution pictorial background information, then the film system becomes a strong contender if the update time is acceptable.

(a) Fixed Format - Tabular. This type of presentation is best illustrated by citing two examples of present usage: alphanumeric readouts used by stock market; and status displays used by the command control center. It is composed of fixed header and category identifiers with limited but variable presentation of alphanumerical performance values and status indicators. These displays are especially characterized by their prolonged usage without modification of the format. Modification of any kind, including expansion, requires physical reconfiguration, at best, and often necessitates equipment modifications. The headers and category

identifiers are normally inscribed on the frame structure with the readout devices located in windows. Since the variable portions of the display usually define the display technique, the alphanumeric readouts and status indicators have the following particulars:

- Predetermined and fixed number of characters in each readout window
- Predetermined and fixed number of colors available in each readout
- Limited digital type input from either manual or computer sources.

(b) Variable Format - Tabular. The variable-format tabular display is identical in appearance to the fixed-format tabular display when in an operating mode. The primary difference is that the variable-format tabular display can be altered completely, either prior to or during the conduct of a mission. The capability for remodeling the display's layout alleviates the necessity for the information to conform to a general pattern. This display device might represent a restricted use of a more general purpose automatic display system. The primary limitation in capability occurs because only the readout portion of the display is continuously updated from the computer complex after the initial generation of the header and category identifiers. Other pertinent characteristics of this type of tabular display are:

- No line drawing capability
- Fixed array of line and rows
- Single size character font of alphanumerics
- Response time of the variable information (readouts) to be of an on-line nature with the time limited only by the readout character technique
- Response time for change in header and category identifiers to be determined by the type of overlay generation implemented (could be manual generation) and is usually in the order of minutes

- Convenient-alteration capability (prior to a new exercise) for the general format and specifics of the header and category identifiers.

(c) Fixed Format - Pictorial. The general fixed-format pictorial display is one in which descriptive annotation is combined with a pictorial representation. A substantial amount of descriptive information together with the basic picture remains static throughout the control center life. This type of display can best be illustrated by a world map on which switchable lights have been mounted to depict the location and status of stationary tracking stations. This type of display can possess powerful utility when the usage is expanded to flow-type control diagrams that can be illuminated for status, control, and events highlighting.

(d) Variable Format - Pictorial. A variable format pictorial display allows for on-line, controlled changes (in total or in part) of the descriptive annotations, pictorial information, and presentation format. It is presently characterized by the general-purpose information retrieval and display systems where the information presented can be any or all of the following types: text, tables, graphs, maps, diagram, and pictures. These can be changed prior to or during any mission. Expandability in information content is solely a function of programming and usable information density.

b. Surveillance Area. Information requirements within the surveillance area are influenced by the nature of surveillance data available and the functional responsibilities of personnel. As a minimum, the following must be included:

- Remote outputs of surveillance radars and location
- Status and location of recovery forces, range aircraft, boats, and ships
- Location of nonauthorized personnel and transport within the prescribed clearance boundaries
- Operations schedules and prelaunch mission progress.

**c. Vehicle Safety Area**

In addition to tabular-status and performance information pertaining to sources of ground-derived measurements, the following classes of information must be accommodated for presentation to vehicle flight safety control:

- Impact-prediction plots, based on external data; and internal data, derived from flight-computer position and velocity outputs, and simulated-flight-computer position and velocity outputs
- Present position plots based on same as above
- Computed mission safe/unsafe indication
- Flight system, subsystem, and component safe/unsafe indication based on telemetry data decisions
- Flight subsystem performance data
- Flight computer output data
- Simulated-flight system performance based on telemetry input.

Two types of formats, tabular and pictorial, are thus indicated. Of these, the pictorial display of meaningful current and projected flight dynamics is most important. Instantaneous impact point, displayed as a ground plot superimposed on a map background and safety boundaries satisfies the most urgent needs after continuous and accurate tracking information becomes available. This should be supplemented by present position as obtained from single, or redundant, ground-based tracking units, or derived from telemetered guidance data. The time response of the display techniques should not exceed ten milliseconds.

The basic means for data presentation must be sufficiently flexible to:

- Permit the weighting of redundant information in accordance with source reliability and mission hazards
- Allow the adoption of different forms of safety rules and criteria
- Facilitate coordination with mission personnel where astronaut safety is involved

- Consider a smooth transition to automatic generation of commands at that point in the flight regime for which human reactions are too slow.

### 3. GRCC DISPLAY AND CONSOLE REQUIREMENTS

The analysis of facility and information presentation needs is based on the GRCC functional organization and operations concepts presented in Section III. V of this report. This analysis reveals that the ground rules for the physical configuration of personnel utilized in 2. a. 1 of this appendix for the LRCC are equally applicable for the GRCC in that: personnel with related duties are to be placed in close proximity; and personnel are to be so located as to have access to displayed information affecting implementation of their assigned responsibilities.

Since the functions of the GRCC relative to global missions are, to the first approximation, equivalent to those for the LRCC relative to local missions, a similar layout is recommended for the main operations area. Overall personnel complements are approximately the same due to the following partially compensating considerations:

- LRCC personnel must monitor global missions for which range support is needed. This tends to increase the personnel needs.
- GRCC personnel must monitor and control all global missions, and be cognizant of all local missions.

#### a. Consoles

Because of the adoption of the operations plan and schedule concept, the basic structure of the information to be utilized at the operator positions is fundamentally the same. Therefore the basic consoles described in Paragraph D. 2. c are applicable and the total quantities, allowing one for each member of the team, are the same as those tabulated in Table I.

#### b. Displays

The display of global range status/progress summary is fundamentally the same as the corresponding display at the local range. However,

whereas the map background for the local range will include only the geographic regions for which the local range has responsibility, the global range status/progress summary must use the entire world map for a background.

One large display area is assigned for each mission, whether global or local, at the local range-control center. From the previous discussions of the relationship of the centers, and the operational responsibilities and control functions at the global range-control center, it is evident that the same information is required for each global mission. Provision has been made for four global mission status/progress displays corresponding to those for local missions at the LRCC. In some cases, a single display is used continuously for a single mission. Data for up to ten satellites in orbit is easily consolidated on one display to permit viewing of range support activities programmed for the next period of time. Since simulation exercises, carried on by the mission control center, may necessitate similar activities at the global range control center, the large displays may be utilized at times for this purpose.

### C. MISSION MONITOR AND CONTROL REQUIREMENTS

The wide variety of missions, to be supported by the global range in the 1965 to 1970 time period, precludes detailed analysis in this section. The primary concern of the global range is to provide an effective, economical instrumentation service. Since mission control and range control functions are closely related, mission control center facilities can also be provided by the range.

The nature of the man-machine interface for manned missions (Apollo and X-20) is briefly examined in the following paragraphs. Particular emphasis is placed on the information requirements essential to ensure the safety of the astronauts, and to provide a basis for those important mission control decisions affected by their condition.

#### 1. INFORMATION REQUIREMENTS FOR APOLLO

The discussions contained within this section summarize the design approach taken for Apollo (Reference 1). The Apollo philosophy relegates the remote site role to a passive form, largely serving as a data relay in the system. Detailed data analysis and comparison of received data

with historical data, including manual correlation and plotting of trend information, will be carried on in the NASA Integrated Mission Control Center.

a. Crew Status

Crew status information is that necessary to monitor the health, safety, and well-being of the crew. Real-time evaluation is required to provide awareness of impending crew failure which could lead to termination of a mission, and to yield information for establishing duty cycles and task responsibilities. The following parameters are considered to be the minimum requirements:

- Respiration : rate and volume
- Skin temperature
- Blood pressure
- Electrocardiogram (EKG)
- Pulse rate
- Voice
- Observation by other astronauts.

b. Biomedical Experiments

Many factors, such as the space available aboard the spacecraft and the number of available telemetry channels, will determine the number of mission medical packages. At least four types of sensors may be added to accomplish biomedical experimentation:

- Electromyograms
- Phonocardiograms
- Electroencephalographs (EEG)
- Galvanic skin response (GSR)

c. Internal Environment

Adequate information must be telemetered from the spacecraft concerning the condition of the following on-board environment:

- Cabin oxygen partial pressure
- Cabin pressure
- Secondary oxygen valve open-closed
- Cabin carbon dioxide partial pressure

- Acceleration
- Parameters concerning the pressure suits when they are worn.

d. Environmental Control Systems (ECS)

Information transmitted concerning the ECS should be sufficient to indicate the status of the ECS and also indicate the seriousness of any malfunctions which occur. Information must be telemetered from the spacecraft concerning the condition of the following system:

- Status of consumables (water, food, etc.)
- Oxygen quantity
- Nitrogen quantity
- Oxygen supply temperature
- Oxygen supply pressure
- Nitrogen supply pressure
- Coolant pump parameters
- Coolant temperature
- Evaporator temperature

e. External Environment

The external environment to be monitored is radiation. Included in this category, are flux density and the energies of electrons, X-rays, gamma-rays, protons, and neutrons.

2. INFORMATION REQUIREMENTS FOR X-20

Real-time data requirements for the X-20 mission are largely concerned with providing effective support to the pilot in the critical flight regimes. This section is divided into two topics: flight monitor and control; and bio-medical monitoring. Both are essential to proper analysis of the manned mission, one being more intimately related to the ability of the man to perform his function.

a. Flight Monitor and Control

There are three information categories: vehicle status, flight dynamics, and navigation. The pilot is vitally interested in all three. A controller on the earth, should the pilot be incapacitated, is equally interested. Status includes those factors indicating capability of the vehicle to perform the mission: remaining fuel, structural integrity,

thrust, electronic subsystems, guidance, and temperatures. Flight dynamics encompasses roll, pitch, yaw, turn rate, altitude, vibration, velocity, acceleration, and maneuver capabilities and limits.

Navigation, while influenced directly by flight dynamics, relates also to the mission trajectory. Vehicle control from launch, through injection, reentry, and landing ensures that specific mission objectives, contingent upon attainment of the planned profile, are accomplished.

Despite the fact that much of the monitor and control information is derived from vehicle sensors, and is supposedly available to the pilot, the analysis and correlation of these data, together with that obtained from the instrumentation network, can most effectively be performed by teams of competent specialists on earth. Conclusions, recommendations, and specific flight directions can then be provided to the pilot as landing instructions are given to aircraft by air traffic control personnel.

b. Biomedical Monitoring

The requirements for biomedical monitoring assume particular importance for X-20 because of the pilot's role. Whereas the Mercury capsule reentered as a spent ballistic body, the X-20 will explore various regimes within the flight corridor with the pilot at the controls. It is imperative, therefore, that sufficient data be available for analysis on the ground to assess his capability for accomplishing the demanding tasks.

There are two pilot-decision periods which influence the extent of biomedical monitoring to be specified: (1) preinsertion (the decision to abort or continue must be made); and (2) reentry (manual control of vehicle from orbit, or suborbital trajectory, through aerodynamic regime, to landing). Reentry has the greater influence on shaping the telemetry and biomedical display because of the environmental stresses to which the pilot is subjected. The ground crew and surgeon can and must aid the pilot in making his decisions. Basically, data is provided on the ground during the flight phases as follows:

- Launch - biomedical and systems; FM and PCM
- Orbit - systems, PCM
- Reentry to landing - biomedical and systems; FM and PCM

Systems data, as employed above, refers to that discussed in the preceding section on flight monitor and control augmented by selected low-bandwidth environmental information. Biomedical data includes physiological measurements indicative of the pilot's condition and performance capability. Voice communications with the pilot are absolutely essential from reentry to landing. It is considered vital for assessment of pilot condition and for checking the on-board monitoring system reliability by having the pilot verbally report his status indicators. On-orbit coverage for voice should be the maximum feasible.

Still another parameter to be considered for biomedical monitoring is the electroencephalogram (EEG). Because of the bandwidth requirements, it would be categorized as waveform category data.

### 3. DISPLAY REQUIREMENTS AT REMOTE SITES

For purposes of this discussion, it is assumed that monitoring of life-support system information takes place at the remote sites. Monitoring can take place at the mission control center (MCC). The decision to employ remote site monitoring would probably stem from the dependence on voice monitoring and for extensive data, coupled with the inadequacy of communications between the remote sites and the MCC.

#### a. Data Characteristics

A quick review of the data quantities for Apollo and X20 leads to an immediate classification of each quantity into one of two types:

- Quantitative data for which the value and trends are significant, e. g. , pressure (these data are readily presentable in numerical readout or graphical form).
- Waveform data for which the significant information is contained in waveshapes, amplitudes, phase relationships, and frequencies, e. g. , EKG.

The nature of waveform data, coupled with noise stemming from various sources, complicates the collection, recording, processing and interpretation. A typical EKG is nearly periodic, with a frequency of approximately one per second. It is characterized by relatively low frequency and small amplitude components, except for a sharp spike

of approximately one hundredth of a second duration. Interpretation of EKG's, single or multiple, (corresponding to vector cardiographs) is apparently based on the waveshapes, and amplitudes. However, the desirability of quantizing through amplitude sampling for digital storage has been recognized (Reference 2). A sampling rate of 1000/sec permits excellent reproduction of the original waveform, and lower sampling rates provide satisfactory results.

Standard parameters for the EKG have been defined and computer programs have been written and utilized in deriving such parameters from sampled waveforms. In one instance (Reference 3) the analysis was based on a 5-second duration EKG, sampled at the rate of 625/sec. The parameter set consisted of eight amplitudes, five durations and four intervals, for a total of 17 parameters. The computer program was executed on the LGP30 and yielded a four-digit printout for each parameter.

The data processing approach just described is significant to biomedical monitoring for two reasons: (1) it suggests an approach to the fully automated sensing of trends and current conditions; and (2) it implies a possible technique for data compaction either in the spacecraft or at the instrumentation station. For the example cited, a total of approximately 25,000 bits, assuming eight bits per amplitude sample, are compacted into roughly one percent of that number.

Another example of waveform data, is the electroencephalograph. The bandwidth generally considered for diagnostic purposes for EEG is 0.5 to 80 cps (Reference 4). A technical paper, dealing with computer techniques for study of EEG, reports 8-bit amplitude samples taken at the rate of 300/sec (Reference 5).

#### b. Data Processing

As a minimum, the data processing at a remote station in preparation for display must include calibration and scaling. Additional data processing functions are those which are presently associated with preparation for transmission, e. g., data selection. With the concept recommended here, and explained in more detail in the next section, historical information, some of which has been obtained prior to the mission proper, must be stored and retrieved for comparison with

current data. The generation of effective display (or printout) formats is also a data processing function.

Additional techniques, ranging from the setting of limits providing automatic cueing to the observer to the derivation of significant parameters from sampled values of the telemetered quantities should also be considered.

c. Station Design Considerations

Figure 6 contains the instrumentation station concept for handling telemetry data. Two receiving chains are illustrated here, the pulse

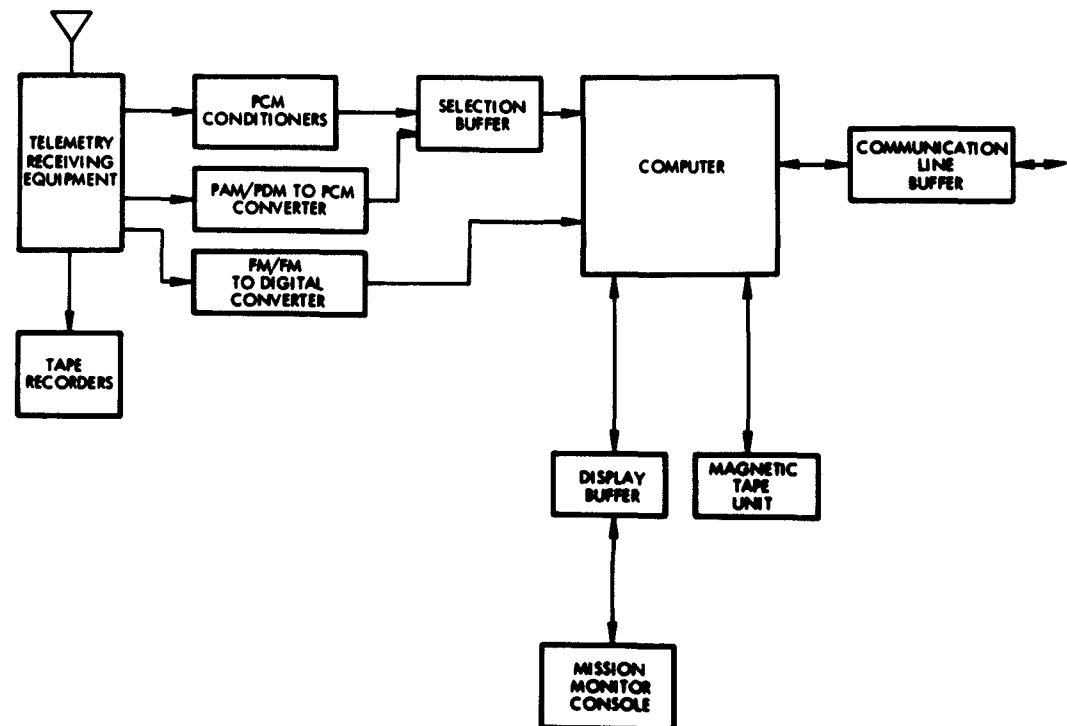

Figure 6. Instrumentation Station Block Diagram

code modulation (PCM) and the analog data chains. Disregarding the addition of the display and the digital tape recorder shown in the dashed area, the following significant features should be noted:

- The recording of all incoming telemetry data on the appropriate digital or analog recorders

- The transmission of selected, compacted data in digital form
- The ability to alter selections on the basis of received messages for either the PCM or analog telemetry channels.

The present practice in telemetry ground stations is to provide strip recorders to permit the monitoring of the several decommutated telemetry channels. Although the motives for this form of recording/display are somewhat undefined, only one has validity under the present concept of nonmission-oriented personnel manning at the instrumentation stations. This one pertains to the assigned responsibility of insuring proper equipment operation within the station. This last bonafide objective may be best accomplished by utilizing a display of the type shown, driven by selected quantities in digital form. There would be, in addition, a limited complement of strip recorders and oscilloscopes to permit the isolation of malfunctioning equipment as evidenced initially by display of the corresponding quantities at the display console.

Referring again to Figure 6, the effectiveness of the biomedical observer is enhanced by the addition of a digital tape unit which contains premission records of the parameters which have been obtained for the astronaut. It would be possible to simultaneously view the EKG, for example, in real time as well as previously obtained records, stored on the digital tape machine. It would also be possible to select particular historical records obtained under similar stress conditions in the simulation laboratory before the mission.

Adhering to the basic assumption that primary biomedical monitoring and decisions are to be performed at the mission control center, there is still another important function for the biomedical observer at the remote site. With communication channel limitations, a remote site observer has the maximum information at his disposal. He may both monitor the uncompact data corresponding to a particular biomedical quantity, and compare it with the compacted quantity. He would then be in a position to judge whether the compacted data is truly representative of the life support system condition.

**d. Console Functions**

The console functions required to permit the capability previously discussed are as follows:

- Communication station
- Voice monitoring
- TV monitoring
- Numerical readout of parameters
- Tabular display of parameters
- Graphic display of parameter updated
- Graphical display of waveforms and patterns
- Graphical display of historical waveforms and patterns
- Selection of display quantities, scale factors and time periods.

**4. DATA ANALYSIS AND DISPLAY FOR MISSION CONTROL**

This section contains a broader analysis of the mission control information display requirements. The biomedical aspects are reviewed with particular emphasis on recovery operations of the X-20 mission. The consoles and displays for the mission control functions are defined in less detail than those for the range control functions.

**a. System Monitoring**

Mission personnel must have accurate and timely information regarding both the system under test and the supporting range- and user-furnished facilities. Attention is here concentrated on the vehicle and user facilities, excluding the biomedical monitoring to be considered in paragraph 4b.

**1. Vehicle Status**

Since one, or a small number of technical specialists can best judge the detailed vehicle status, including flight dynamics, a console approach to data presentation is appropriate. Conventional numerical readout, augmented by status lights would provide marginal capability. The better approach would be a graphic presentation of critical parameters, e. g. , angle of attack, with superimposed limits.

A pictorial representation of the vehicle, with flight dynamic data, and related measured quantities, e. g. , skin temperature at selected points, could be supplemented by the other means mentioned. Most of the pertinent data could be so summarized that current or impending trouble would be immediately detected, allowing concentration on the course of action for correction. For example, semiquantitative vehicle skin temperature would be indicated by brightness at the appropriate points on the pictorial model. The responsible operator would read telemetered values, compare with limits, and determine what advice to give the pilot.

## 2. Navigation and Guidance

A dynamic display of present position, nominal path, and maneuverability limits in three dimensions would provide the basic information. This would be augmented by numerical or graphic presentation of navigation or guidance quantities, which cannot readily be judged from spatial relationships. These latter quantities might include velocities, accelerations, thrust, and guidance errors.

A dynamic display has the particular advantage of allowing optimum energy management paths to be updated as the flight progresses. In lieu of an effective three-dimensional display, a synthetic two-dimensional display simulating perspective would be effective. A set of two-dimensional displays representing cuts in three-dimensional space is readily implemented, with some loss of effectiveness.

## 3. Ground System Status

There are techniques appropriate to the presentation of the instrumentation network status for the global range. However, range status would be confined to those range elements operating in direct support of the mission. In addition, the status of the computers and other control center equipments, which are not necessarily part of the global range, must be determined. Critical aspects of certain flight regimes, reentry in particular, dictate careful selection of techniques, display modes, and configuration to allow rapid appraisal of prime and backup ground equipment status, and to facilitate decision and action in the event of malfunctions.

#### 4. Situation Summary

The interrelated characteristics of monitor and control information classes treated separately in the preceding paragraphs, e. g., vehicle dynamics and guidance, pose a serious challenge to the decision maker. A tightly knit operating group is necessary; effective intercom, facility layout and training are essential. Careful design of a situation summary display, suitable for group viewing, would provide a powerful team integration tool. By this means, the team head has the basic information before him, and he is able to ask for explanation and interpretation from the appropriate team members.

Inclusion of the capability for viewing a pictorial representation stripped of all but the more important control information should be considered. If TV techniques are used in implementing consoles, a group display of all or selected parts of the same data is possible by proper configuration of the display generation and distribution system.

##### b. Biomedical Monitoring

This section relies heavily on the preceding discussions regarding Apollo. X-20, and the nature of displays for biomedical monitoring at the instrumentation stations. It is the purpose here to expand the display functions to include premission activities and postmission analysis.

##### 1. Preflight Data Collection and Analysis

During the mission preparatory stages, the astronauts undergo a period of rigorous training. This includes performance of tasks under simulated operational and environmental conditions. Data so obtained might be effectively used to accomplish the two following objectives:

- Development of techniques for characterizing the biomedical quantities
- Preparation of historical data for use during the specific missions.

This period would afford an excellent opportunity for the evaluation of compaction techniques for use during the mission. If consoles of the same general type recommended in the previous sections for the instrumentation stations are employed, this period would permit the medical observers to become familiar both with the operation of the

equipment and the form of the displayed data which they may utilize during the mission proper.

The power of the consoles provides an excellent means for basic research into the medical interpretation of such data. Correlation between data from different sensors, optimization of sampling intervals, development of different derived parameters, and mathematical representation of significant measured patterns can be more effective and timely.

## 2. Mission Support

The functions for mission support are exactly analogous to those previously described for the instrumentation station. However, it becomes more practical to employ a number of medical specialists, together with a larger volume of historical and experimental data. Although many of these extra data might be put into digital memory, this should not exclude the use of material in hard-copy form.

## 3. Postmission Analysis

Although the purpose for data processing may be altered significantly after the mission, the same techniques, and especially those used prior to the mission, will be applicable. Priority is always given to the investigation of cause and effect associated with unexpected events. The more leisurely analysis of nonreal time data, including that available from on-board recorders, is often the basis for explaining phenomena whose origin was formerly a mystery. Besides mission data for documentation of results relative to mission objectives, the analysis provides additional historical information of potential use in preparation for and support of future missions.

## 4. Console Functions

To a large extent, the same console functions would be required at the MCC as were elaborated for the remote site. However, the following additional features would be beneficial to aid in performing analyses.

- Operator pointing (cursor and light gun)
- Expanded controls and indicators.

## D. SYSTEM IMPLEMENTATION

This section contains a brief review of the display requirements, a consideration of additional factors in system and equipment design, comparison of various alternate approaches to implementation, and recommendations for specific implementation.

There are a number of systems, each having considerable flexibility, in the actual configuration of the global range. These include the control center display, manned spacecraft monitor and control, and the instrumentation station. Of these, the control center display and console system is the most complex.

### 1. CONTROL CENTER REQUIREMENTS

The basic display and console system is based on computer-generated video distribution and presentation. The factors leading to this approach fall into the areas of systems considerations and equipment performance characteristics. The detailed rationale supporting these conclusions is discussed in the following paragraphs.

#### a. System Considerations

Two different points of view will be utilized in considering the display and console complex in the control center. The first is related to the operational aspects of the control center and depends upon the control concepts, personnel organization, configuration of the control center and operating areas, and information flow.

The second is concerned with the production and distribution of information itself. The governing factors here are; methods of generation, distribution, presentation, and control.

#### 1. Integrated Data Presentation Concept

The operational concepts for the control center are probably the most important factor shaping the overall design. Incorporation of the operations plan and schedule into the computer memory, coupled with the decision to place all control data into digital form within the data processing system at the most convenient point of entry, dictates a highly integrated, computer-driven, man-machine complex. Operations plan and schedule information is embodied in a hierarchy of detail

levels communicated to the operating personnel at the displays and consoles. Those detail levels are grouped to permit accessibility for those personnel having common interests in the large displays and the individuals having particular mission and technical responsibilities at the consoles. It is necessary that the personnel who direct the range operations not be required to have particular competence in the display, data processing, and console technical disciplines.

Based on a functional organization of personnel and control data needs, a model facility configuration has been designed. Functional personnel areas have been laid out to permit access to the required data and to facilitate communications between the personnel who must work together most intimately.

There are two important facets of display update time. First, individuals entering data by means of their consoles must have the capability of reviewing such data before it is entered into the computer data base. Moreover, when information is selected for review by personnel working at the consoles, long time delays are intolerable. The system reaction time should be less than 5-seconds, at most, including data processing time. The second important aspect of the update time is the closely related data presented by the large displays and at the consoles. Differing only in the level of detail, confusion would be inevitable if the reaction time for the displays was greater than that for the consoles. Therefore, the same update time requirements apply to both.

It is necessary that specific individuals be assigned the responsibility for ensuring the accuracy of all data presented for common use on the large displays. Thus, the instrumentation personnel must review any changes, generally before updating on the large displays, to ensure accuracy. This means that not only must the displays and consoles interface through the computer, but also that the data presented by both be absolutely compatible.

## 2. Display Generation and Distribution

As discussed in the preceding section, the operational concepts adopted for the control center indicate the need for not only a high order of compatibility between the displays and the consoles, but

also the desirability of a common display generation and distribution system. Personnel working under somewhat less intimate conditions with the main body of the control center operational staff are located outside of the main operations area, and specifically within the surveillance area. A possible need exists for personnel in the surveillance area to have limited access to the basic control data used within the main operations area. In brief, there is a need for monitor stations there, as opposed to the basic console. Moreover, it is expected that status boards and maps will be maintained by the personnel in the surveillance area and the ability to view these from positions within the main operations area would be valuable.

Economy is a most important consideration in the implementation of a large-scale data presentation and control system. Where there are a number of separated locations, each needing the same data, a common use of a single means for generating this data is indicated. The operating stations would then be free to attach themselves to the distribution bus leading from that display generation equipment, and since there are a number of simultaneous needs for different data, there would be a complex of buses. This approach to the display generation and distribution is amenable to the use of identical equipment modules of which there might be one for each display channel.

### 3. Design Adaptability

Even a careful analysis of data presentation and system control requirements cannot predict the exact use to which it will be placed in the future. The system should be considered as a tool capable of being adapted to the ingenuity of the control center personnel. Changes in operating procedures must be anticipated; the capabilities should be amenable to expansion by modular addition. The system should provide for training, briefing, simulation, and rehearsals, although a prime objective of the operational concepts is to minimize the amount of rehearsal time necessary.

Besides providing for the incorporation of data arising from remote sources and in different forms, as discussed above for the surveillance area, it may be desirable to integrate other information sources in the future. An example would be the use of radar PPI data presentation.

Looking ahead to the time when man-machine communication becomes more of a science than the art it is today, the generation of meaningful pictorial presentations by synthetic techniques is a distinct possibility that has great promise (Reference 6).

#### b. Equipment Performance Characteristics

Data presentation at the large displays and the consoles should be compatible in update time, formats, and resolution. However, since the greater implementation problems are associated with the large displays, particular emphasis will be placed on these in the following discussions.

##### 1. Formats

As described in Subsection V. of Section III, the display requirements can be satisfied by four formats as follows:

- Fixed format - tabular
- Variable format - tabular
- Fixed format - pictorial
- Variable format - pictorial

Although certain parts of the displays have more limited requirements, the system in general will embody all alphanumerics and a fairly limited repertoire of symbols, probably less than 100, although the system should be designed to accommodate 256 as recommended in RADC-TDR-62-315 (Reference 7).

##### 2. Resolution

It is difficult to specify required resolution without considering implementation techniques. Briefly, computer-driven film projection systems are capable of high resolution and brightness on screen, (120 x 240 characters is a standard general requirement) although they are slow, expensive, and have many other shortcomings (Reference 7). The resolution problem is delineated by the data which must be presented in pictorial format. Consider the presentation of selected fragments of the operations plan and schedule in a "PERT-like" form. It is unlikely that the display of more than 10 to 20 related events at a single time would be useful. It must be remembered that should the operator choose to see his particular level of detail he will have reference to two higher orders, that is, lesser levels of detail, on the large displays for orientation and reference purposes.

Without annotation, commercial television quality (16 x 32 characters) is marginally adequate. With 840 active lines yielding 28 x 56 characters, coded annotation is possible (Reference 8).

In addition to the pictorial representation, which would be used in common on the large displays and consoles, the consoles must display formatted status messages. The adoption of resolution available with commercial quality TV is unnecessarily restrictive in the number of characters per line. However, with high resolution TV, that is 840 active lines, or optical pairs, the presentation of textual messages is adequate.

### 3. Brightness

The main operations area has been designed to reduce incident light on the large displays while providing sufficient illumination at the consoles. Proper placement and collimation of light in the background sources achieves these aims and reduces specular reflection from console working surfaces. By designing each large display to be a composite of the several format types mentioned, it is possible to reduce the display screen size, thereby reducing the on-screen brightness problem and, incidentally, helping to alleviate the resolution and contrast requirements. A value of 25-ft lamberts will suffice for the large displays.

### 4. Color

Although color is desirable for all of the displays and consoles, economic justification cannot be provided for more than the range status/progress summary display. Since this particular display includes information pertaining to several missions at the same time, it would be convenient to color-code the data pertaining to each, and key this to the individual mission status/progress displays. Because of the map background, facilities status, subtrajectory tracks, and possible annotation necessary, color is believed essential.

## **2. RECOMMENDATIONS FOR CONTROL CENTER DISPLAY AND CONSOLE SYSTEM**

This section contains a description of the data presentation and control system for the control centers. Three factors were considered: (1) a central video display generation and distribution complex, EIDOPHOR

projection, raster scan, pictorial presentation at the consoles; (2) readout by computer-driven electroluminescent coded and alphanumeric panel elements for the large display and console variable format tabular requirements; and (3) on-line access to the computer by means of individual operator controls at the consoles.

a. Generation and Distribution

There are basically two alternatives to display generation and distribution:

- Use of separate generation and distribution techniques, each tailored to one of a number of adopted data presentation techniques (small weight is given to the use of common, standard units of minimal variety)
- Adoption of single integrated system with maximum standardization of unit types, having suitable characteristics to satisfy the general needs

In selecting the integrated video display generation and distribution approach, the foremost technical problems were those associated with the utilization of data, having many common features, to actuate the large displays and the consoles; however, the feasibility of implementation for the large displays, in particular, is most important in the approach.

1. General Description

The basic system for the generation and distribution of pictorial information is illustrated in Figure 7. A display generator receives digital data from the computer. The display generator provides appropriate analog voltages and control signals to each of several scan converters. The scan converters are tied into a video bus or distribution system to which are connected the consoles, the EIDOPHOR projectors, and TV monitor stations. All selection and control stems from data entry at the consoles.

2. Display Generator

Each display generator must be capable of receiving digital data from the computer at a standard rate of 62,500 six-bit characters per second in sequence. The first characters in each received block are

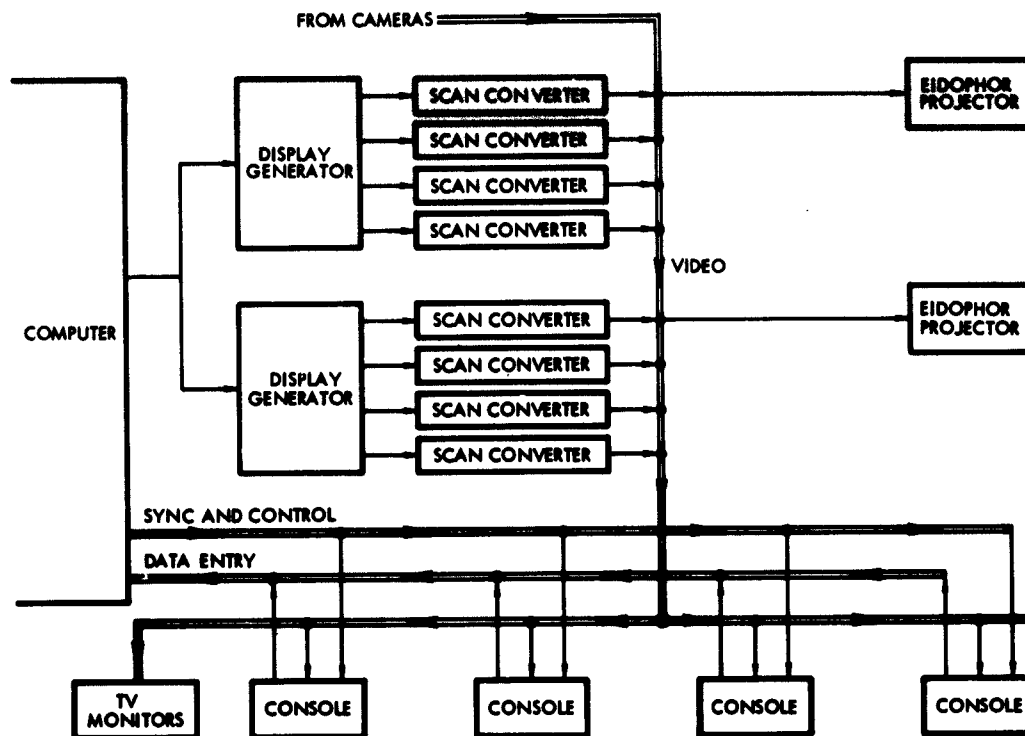

Figure 7. Display Generation and Distribution System

decoded, and identify whether or not a given display generator is to act on the information contained therein. If the proper address is received, a number of characters are assembled, decoded and caused to generate one segment of the display. Each successive group of characters generates a new segment of the display until a block, intended for actuating one scan converter, is exhausted. The next block, if addressed to that display generator, is likewise accepted and identified as corresponding to the next scan converter in an arbitrary sequence.

### 3. Scan Converter

The heart of the scan converter is a dual-gun recording storage tube. This tube contains two electron guns, located on opposite ends, one of which is for writing on the storage element in the center, and one for reading the stored information. The electron guns have independent deflection circuits. The electron beam from the writing guns of all scan converter tubes attached to the same display generator will be deflected in unison; however, only the one scan converter for which the group of characters within the display generator pertains will be unblanked at this time. Rewrite of any scan converter will occur after erasure,

which may be once every 1 to 10 minutes unless updating requires repetition of the process.

Storage is accomplished by a dielectric material surface deposited on a wire mesh or screen near the center of the tube. When the read beam, emitted from the read electron gun, strikes the dielectric screen, a video signal is produced corresponding to the condition in which the dielectric element was left by the write beam. Reading is accomplished by using deflection of the read beam in the characteristic TV raster scan. The output of the scan generator is a set of synchronizing and video signals suitable for driving the TV monitor, the consoles, or the EIDOPHOR projector.

#### 4. Display Selection

All display selection and other control functions originate at the consoles as data which are entered into the computer. Such control might take several forms. If some data on a given display format is to be changed upon entry of the proper control codes into the computer, the computer executes a program to modify the digital outputs to the appropriate display generator feeding the right scan converter. If the operator at a console wishes to select a different set of data for presentation and viewing there, his selection is entered in coded form into the computer which causes one of two things:

- If the data requested is available in appropriate form from a scan converter, it sends out the proper control signal to the console for selection there of that channel.
- If the data is not available at a scan converter, the computer generates the data, selects the display generator and scan converter, hence channel, and causes the console to be switched to that channel.

In much the same manner, designated console operators control the displays which are viewed on the EIDOPHOR which is connected to a given channel. The TV monitors, which are located in remote areas, have the capability of manually selecting one of several channels on which the display format is predesignated.

Still another aspect of the system is not illustrated in Figure 7. A full-color EIDOPHOR projector will be recommended subsequently for implementing the range status/progress summary display. The inputs to the EIDOPHOR for this purpose must originate at three scan converters and be conveyed over three channels. The use of different colors for that particular display must be carefully planned, with perhaps each color corresponding to a given mission and/or some specific category of information displayed in pictorial form. Despite the recommendation for the use of multicolor video on that one display, it will be possible to synthesize display channels utilizing combinations of the three scan converter outputs corresponding to the three primary colors. Therefore, operators at the consoles, and especially personnel utilizing the remote TV monitors, may select the entire full-color range status/progress display in monochrome or selected subsets of this data as desired.

#### 5. Computer Load

The data processing load on the computer is dependent upon such considerations as the number of missions in progress, the frequency with which individual displays must be updated, and the frequency with which console operators request service from the computer. An additional factor is the frequency with which status is reported, which implies a readout from the computer to the consoles, together with the generation of pictorial, perhaps textual, data on the appropriate console tube face.

The 62,500 characters per second transfer rate corresponds to the present standard tape unit to computer transfer rate. Allowing six characters of data from the computer per equivalent character or line segment of the resulting display, (a total of 1,024 maximum such display elements under peak load conditions for each display, and 32 display channels) each display channel is updated every 3.2 seconds. It is possible to construct the equipment and plan the programming so that the maximum time delay is directly proportional to the overall display load which is rarely at the peak here assumed.

The time-sharing nature of the generators is also significant. Such devices have been fabricated in the past to generate in excess of 1024 symbols, characters, or elements per frame at rates up to 60 frames per second, that is, one frame each 16.7 milliseconds. Thus, under the load

conditions hypothesized in the preceding paragraph with an input rate of 62,500 characters per second, it is possible for one display generator to service all 32 channel scan converters. In order to provide backup capability, two or more display generators would be provided for a system of the magnitude used in the example.

**b. Display**

In this section a number of competitive techniques for satisfying the four types of display formats are considered.

**1. Fixed Format - Tabular**

The display techniques that are applicable to the variable portion of the fixed format - tabular displays are listed with reference to their limitations in color.

**(a) Two Color (black and white, or black and one color).**

These include electromechanical readout devices in which a character forming stencil is mechanically moved into an optical projection path or directly into the viewing window; electrical readout devices that translate coded inputs into gaseous glow tubes that are shaped to form a character (these are normally of the direct view nature); electroluminescence readout devices that translate coded inputs into electrically activated phosphor-coated areas that compose a character; and indicator lamps that are color coded to indicate status and are controlled from either a manual or computer input.

**(b) Multi-color (including black and white).** These include electromechanical readout devices in which the coded input is translated to select the optically projected symbol and a mechanical color generator. The color generation can be obtained by either color filters or by the selection of symbols etched on polarized color templates with on-off gating by another polarized material. Film or diazo projection overlay systems are also utilized. These project the alphanumeric into the window from information generated onto the film or diazo type transparency.

The implementation technique best suited for these displays will be refined models of the present day electroluminescent readout devices. The factors governing this selection are:

- Electroluminescent type devices will be necessary in the variable format tabular displays. Since both equipment and program control techniques will be developed for these, compatibility between techniques should be utilized.
- Response capability of single readout character changes in less than 10 milliseconds.
- Adaptability to minimal level of ambient lighting is necessary in this working environment.
- High degree of performance is expected to be available at low cost in the post-1965 time period.

## 2. Variable Format - Tabular

Many display techniques yielding variable formats for pictorial presentation might be considered for the variable tabular format. Some of these techniques are expensive and appear to offer greater flexibility, and yet do not fulfill the primary criteria for the design of an optimum tabular display. These are:

- Random, single-character update of the readout portion of the display without regeneration of any other portion of the display
- Random, single-character erasure of the readout portion
- Character memory as an integral part of each readout character.

An example of a system technique that appears to have superior capability when applied to the variable format tabular display is the general purpose film generation and display system. This system offers automatic, rapid change in both header and readout information but its basic design requires that a complete regeneration of the header and category identifiers and all readouts occur when one readout character is changed. The tabular display should not require this complete regeneration when updating individual readouts.

The implementation of variable-format tabular display is usually a combination of the techniques used in the general purpose display devices with the readout devices that are utilized in the fixed format tabular display. The three general categories of these displays are:

- Fixed array of all readout elements such as an entire panel of electroluminescent or mechanical readouts
- Overlay projection of the header information from a film or diazo type transparency with darkened windows available for screen-mounted readout elements, such as electroluminescents
- Overlay projection of the header information from film or transparency with the readout being projected from either a separate video driven light valve or film generator.

The limitations of each technique are associated with the ability for color change, single-character update, and response time for a change in one readout character.

Table II shows a comparison of each general technique. Significant characteristics of competitive techniques are summarized in the following paragraphs:

(a) Electroluminescent Systems. Electroluminescent elements presently have many disadvantages. It is believed that adequate brightness at nominal cost, including switching and self-contained memory will be available in the post-1965 time period.

(b) Electromechanical Display. The all electromechanical device type display possesses the best qualities for both color or update of a single character but has a poor response time for a major update.

(c) Film Projection System. The film projection system can be termed slow for most tabular displays since the requirement for single character change occurs more frequently than a complete update in tabular type displays.

Table II. Comparative Characteristics of Variable Format Tabular Displays

Technical Description	Implemented Systems	Capability for a Single Readout Character Change		Approximate Response Times			Type of Information Storage	
		Character Update	Color Update (Other Than on/off)	Single Readout Character Update	1000 Readout Characters	All Information	Readouts Information	Header Information
All Readout Type Devices	All Electro-mechanical devices	yes	yes	0.02 sec	20 sec	40 sec	Readout Devices	Readout Devices
	All Electro-luminescent devices	yes	one Color	10 $\mu$ sec	0.01 sec	0.02 sec	Logic Control Units	Logic Control Units
Overlay Projected Header Information	Film Projection + Electro-mechanical	yes	yes	0.02 sec	20 sec	40 sec	Readout Devices	Film
+ Screen Mounted Readout Devices	Film Projection + Electro-luminescent	yes	one Color	10 $\mu$ sec	0.01 sec	4 sec	Logic Control Units	Film
Overlay Projected Header Information	Film Projection + Film Projection	none	none	4 sec	4 sec	4 sec	Film	Film
+ Projected Readouts	Film Projection + Video Light Wave	none	none	1/60 sec	1/60 sec	4 sec	Computer Type Memory	Film
	Film Projection + Opaque Printer Projection	none	none			4 sec	Print Copy	Film

The requirements for completely reformatting both header and readout information may be best satisfied by electroluminescent devices that possess the capabilities for providing the following display particulars:

- Fixed array of character positions in 30 rows and 60 columns to supply detail range status and similar information
- Character font containing the upper case alphanumerics plus a minimum of three colored blanks
- Response times of less than one millisecond per character change
- Ambient light output capability (20 ft lamberts minimum) in an environment designed for individually-lighted desk or console work.

### 3. Variable Format - Pictorial

With introduction of information retrieval and display in the general command control field, the group displays of the variable format-pictorial classification have stimulated the applications of many techniques. A listing of the candidate techniques for implementing the present requirements are:

- Schmidt optics projection of video
- Control layer projection of video
- Film projection
- Electroluminescent elements.

All of the techniques grouped above possess characteristics that allow for their meeting the general minimal requirements for many variable format pictorial group display applications. These requirements are:

- On-line (automatic control) update of pictorial and descriptive annotations
- Rapid update of information presented
- Response to randomly located color change
- Presentation on an area greater than 20 sq ft with adequate intensity and resolution.

(a) Schmidt Optics Projection of Video. This technique involves the coupling of Schmidt optics with a high output cathode ray tube for projection. The strongest attribute of this system is the fast response times offered by electron ballistics of the CRT picture source. This technique has been adapted to both sequential color (color filter wheels) and simultaneous color (primary color addition from multi-generators). Although speed, color and ease of video distribution offered the potentials required in automated group display systems, the advance in this field has been curtailed by the light output intensity required in group displays.

(b) Control Layer Projection Video. Two general types of control layer light amplification for video projection have been implemented. These are: the oil film control layer; and the thermoplastic control layer. Both of these techniques produce an image from light diffracting deformations produced in a fluid material by electron beams. These deformations are electronically varied in depth to provide controlled amounts of scattering of high intensity projection light which is directed on or through the layer. The scattered light, alone, is then allowed to pass through matched apertures into the projection optics. These techniques were developed for color, and meet most group display requirements for screen brightness. At present the only significant systems limitation falls in the area of resolution. Near future developments (1964 to 1965) are directed toward 1000 optical lines on screen, which is adequate for presentation of most types of information.

(c) Film Projection. The technique of generation of the information onto film and then subsequent projection or storage has been the most thoroughly explored of the techniques utilized in the group display field. Variations in the application of film-like materials, diazo, silver halide, and photoconductive materials, are presently used in operational systems. These systems, in general, offer the greatest potential in light output, resolution and the inherent memory capability of film. Their most significant limitations are: response time, complexity, and continuing consumption of raw materials. The shortest generation time presently available in the large information retrieval and display systems is a full frame of information in four seconds with a predicted decrease in response time of two seconds in the near future.

Specific requirements for the variable format pictorial display may be summarized as follows:

- Optional color, or black and white, and annotations for highlighting information in the areas of present path operation, problem areas, relative importance, and information categorizing
- Response time for individual character, full presentation and color change of the order of one second, to present dynamic situations
- Annotations that provide for alphanumeric and line drawings for presenting diagrams
- Pictorial formats that includes diagrams, maps and television pictures for alternative usage during the program and center life.

The display technique that is expected to best present a variable format pictorial display in the 1965 to 1970 period is that of control layer video generation and projection. This display offers response times for complete picture changes in less than 1/60 second, and it provides the picture qualities required for diagrams and some low density information maps. Color is presently available in the three-frame simultaneous projection technique and should be implemented in all presentations that require quick observer response to specific information in a complicated situation display.

(d) Electroluminescent Elements. Considerable research and development effort has been expended in the past few years toward the implementation of large displays using individual electroluminescent elements. A more detailed discussion of this display technique is included in Appendix XXXII.

Perhaps the single most-attractive feature of implementing large displays using active elements is the departure from the need for projecting images. Electroluminescents have the potential advantage of full color, brightness, and adequate resolution for large

displays. Although no system has been fabricated in its entirety, many experts are of the opinion that large display systems employing this technology will be operational within the decade. However, an impressive number of problems still appear unsolved. Included are the development of phosphors for satisfactory color and brightness. One disadvantage, is the requirement for switching the individual display elements, whether by electronic or optical means. Unless individual cell or element memory is successfully attained, electronic switching will be necessary, and the rate sufficiently fast to avoid flicker. The use of electroluminescent elements has been abandoned for implementation of the control center large variable format pictorial displays in the early 1965 to 1970 period for the above reasons.

#### 4. Fixed Format - Pictorial

The following basic approaches are applicable:

- Group display of a permanent background map or diagram and descriptive annotation painted on a rear projection screen with automatically controlled active elements attached to the screen for highlighting either a moving element of the mission, or the situation and status of a mission event
- Group display of projected basic, static background structure with annotation and present situations highlighted from a separate source, such as a light-valve projection of video-generated data
- Group display of the basic background structure by active screen elements such as electro-luminescents with annotation and motion highlighting derived from the projection system.

This display will include a fixed background map of the world, augmented by lights and automatically generated annotation. The annotated information should possess the following capabilities:

- Optional color for highlighting specific information on an already dense information presentation

- Control from either computer or manual information sources
- Track presentation of at least ten vehicles during on-display refresh cycle
- Update response times of less than one second for tracking, and a character or color change.

The display equipments to be implemented for the fixed-format pictorial display consist of a permanent background map projection of the world, painted on a rear projection screen with annotation from on-line generation and projection units. These projection units are required to present part or complete information changes within 5-seconds in black or white or multicolors. The level of information density contained in annotations and superimposed subtrajectory tracks, and the response times required for the update may be satisfied with the control layer video generation and display equipment, EIDOPHOR multicolor projector, connected to the display generation and distribution system.

Besides having the advantage of utilizing equipments in common with the display generation and distribution system, it permits the simple and inexpensive remote viewing of all, or color selected parts of the dynamic information in black and white.

### c. Consoles

The basic console functions, reflecting the primary needs for individual man-machine communications, have figured prominently in the formulation of the system operational concepts. The consoles not only satisfy many of the requirements directly attributable to the system concepts, but basically helped to generate the system concepts. One console, referred to as the basic console, is described in the following paragraphs.

#### 1. Basic Console Description

All console requirements within the main operations Area of the control center can be satisfied by a single console providing several options. Each console has a standard set of data entry controls and keyboard. The options include the following: zero, one, or two cathode ray tubes for pictorial data presentation; and one, two or more, as panel space permits, alphanumeric readout panels. The basic console is supplied in a standard mounting shell allowing the addition of modular sections in-line,

in-line joining to adjacent consoles, or joining adjacent consoles on either side at an angle. Figure 8 illustrates the present conception of the console. The reason for the low profile is to facilitate the use of the console, as one means for data presentation in combination with the large displays.

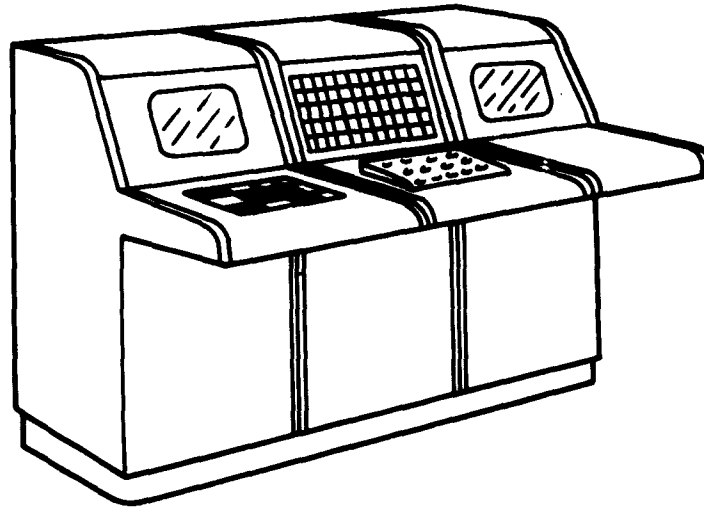

Figure 8. Basic Console

## 2. Data Entry Features

In addition to a standard alphanumeric keyboard and standard control switches, the console has a special 5 x 6 array of switches. Various plastic overlays will be prepared to identify the switch functions for a particular task. Each plastic overlay is keyed so that each switch in the array directs a unique code to the computer, identifying the function and the switch. Under normal circumstances the operator would use one such plastic overlay. It is possible that one might be needed for each mission in which he has some responsibilities. If the particular console configuration (that is, option) implemented is adequate, and the computer programs have been written, an operator can move from console to console with his overlay and perform his task.

This last feature means that sometimes new mission control functions can be performed within the control center without hardware modification. Another attribute of this approach is the interchangeability of consoles to compensate for failures of any console.

### 3. Console Display Features

A small number of different display modules, each capable of fitting into the panel area on the basic console, will be used. As a minimum, one of these display modules will contain the cathode ray tube, and deflection circuitry. Because of the console height limitations, either a 12- or 15-inch cathode ray tube would be used. This module would include standard deflection circuitry and the video switching circuitry for channel selection under the control of the computer.

One or more alphanumeric readout panels employing electro-luminescent character or numeric units would be incorporated.

#### d. Surveillance Area Data Presentation

Three forms of data presentation will be provided for this area:

- Surveillance radar remote indicators
- Monitors (TV) for remote viewing of selected portions of the operations plan and schedule
- Manually updated status boards and maps.

Although the implementation approach might vary depending on the geographic separation of control centers and surveillance radar sites, remote indicators could be either remote PPI scopes or TV monitors using scan-converted video. This latter approach permits integration into the display generation and distribution system, thereby making the same information accessible to personnel throughout the control center.

Appropriately placed TV cameras in the surveillance area will permit the remote viewing of the manually updated status boards and maps. These cameras should be a part of the integrated system for display distribution.

#### e. Vehicle Safety

It is recommended that data be presented on a basic console and on monitors attached to the common generation and distribution system. Considerable flexibility is achieved with this approach, allowing different metric or telemetry sources to be used for driving the different units. A typical configuration would be:

- Basic console - tabular presentation of instrumentation status, raw-data quality, flight system performance confidence factors, and special data requests.
- Monitor No. 1 - composite IIP with safety boundaries and other criteria. Impact point uncertainty based on selected raw data weighting to be shown. Operator to have source selection through basic console controls.
- Monitor No. 2 - present position and velocity during launch from composite of all data sources, or from a selected single source.
- Monitor No. 3 - direct view of vehicle on pad and during launch.

It should be noted that the method of processing raw data from redundant sources is not basically limited by the presentation method chosen. Thus if all data is combined to provide a single meaningful measure upon which the "safe-not-safe" decision can be made, one monitor is adequate. If the redundant sources are treated independently, then a monitor for each can be provided.

A three-dimensional display of position upon which planned trajectory, volumetric limits, and other spatial criteria might be superimposed, is desirable in lieu of Monitor No. 2 above.

A practical three-dimensional display probably will not be available for this purpose in 1965 to 1970. Stylized representation in two dimensions would provide much the same information if properly designed. The possibilities to be considered are:

- Synthetic perspective in two dimensions
- Special two-dimensional cuts.

### 3. MISSION MONITOR AND CONTROL RECOMMENDATIONS

This section discusses implementing the mission monitor and control functions at the instrumentation station and the control center. The presentation of information required for the health, safety and well-being of the crew is important in the selection of techniques and equipment.

However, the real-time monitoring requirements for other than manned missions have been carefully integrated in the requirements, and are reflected in the specific recommendations.

a. Instrumentation Station

The capabilities to be incorporated in the console are

- Communication station
- Voice monitoring
- TV monitoring
- Numerical readout of parameters
- Tabular display of parameters
- Graphic display of parameters updated
- Graphical display of waveforms and patterns
- Graphical display of historical waveforms and patterns
- Selection of display quantities, scale factors and time periods.

1. The Display Cell

The relatively large number of quantities to be monitored suggests that the various ways of presenting data for any single quantity be grouped together within a relatively small area on the console face. **Figure 9 is a sketch of one feasible means of constructing the display cell.** On the left side are depicted two numeric readouts corresponding respectively to the upper and lower halves of the tube face. Below the numerical readouts are lighted switches controlling various aspects of the data shown. The display cell, a number of which are incorporated in a given console, has the following capabilities:

- Graphical presentation of digital data, updated point by point as samples are received, with limits shown occupying one-half of the tube face; the digital readout is to the left.
- A similar presentation for the lower half of the cathode ray tube face of either a second quantity (measurement) or the presentation of the same quantity measured, recorded, and retrieved to allow comparisons with past behavior and trends.

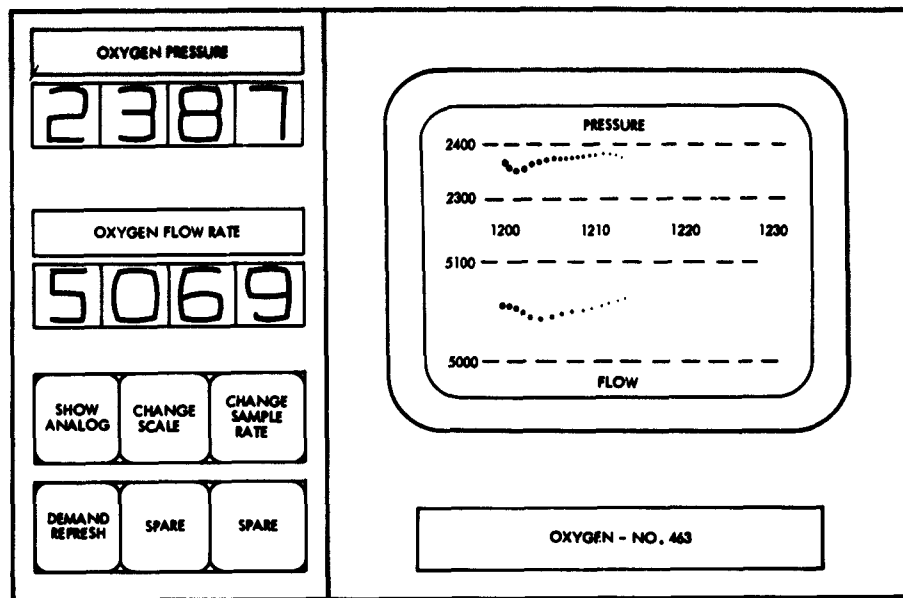

Figure 9. Display Cell

With the particular approach to be taken in implementing the display cell, still another presentation mode is possible. In the event that analog information is available and is to be displayed, either half or both halves of the tube face can be used in the conventional cathode ray tube oscilloscope manner for this purpose independently of what is being shown on the other half. The best cathode ray tube for this application operates with either half of the tube in storage mode or in conventional CRT mode independently of the other.

Adoption of the storage CRT has significant advantages in reduced computer load and economy in implementation where sampled data points are to be plotted as received to allow graphical presentation of values and trends.

## 2. Mission Monitor Console

The console shown in Figure 10 depicts the manner in which the display cells are grouped for the space surgeon. Six display cells, three on either side, are shown. In the center two cathode ray tubes, functioning as TV monitors, together with control keys and digital readouts are shown. With a standard module size, nine display cells would be possible in this configuration. On the horizontal surface of the console are control keys and a keyboard. The keyboard is connected to

the computer and, together with the controls with each display cell, permits the selection and signaling to the computer of any changes of scale factors, display quantities, or selections (as for prerecorded data) made by the operator.

Construction of the console itself is modular, being subdivided into three parts (see Figure 10) so that additions could be made if the number of functions or measurements for any particular application were to change.

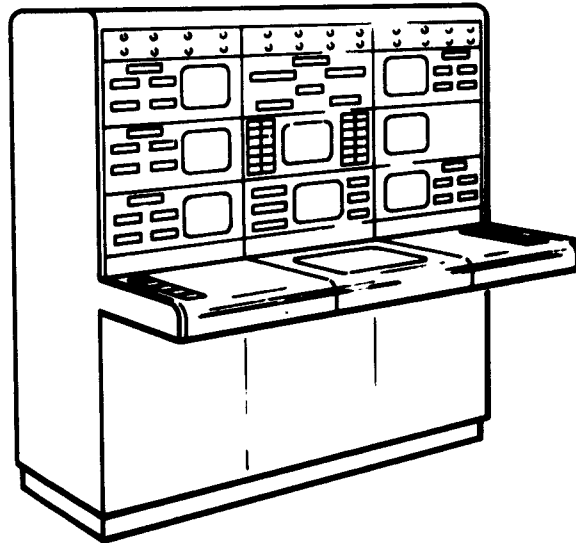

Figure 10. Mission Monitor Console

### 3. Display Generation and Distribution System

The system is shown in Figure 11. Each display cell is driven in parallel with all the rest, using common digital circuitry and the D/A converter. The computer reads out periodically to the decoder; several characters are then stored and those designating the position on the face of the display cell are transformed into analog form to feed the X and Y deflection buses. The deflection circuitry in each display cell is of conventional design and, if all of the CRT were unblanked, the same pattern would be shown on each tube face. However, the decoder feeds a circuit which unblanks either the upper or lower CRT's in the proper display cell at the time to display the next point in the record of that measurement. A character generator is optional to this system and will permit the writing of the selected character in the position designated by the D/A converter.

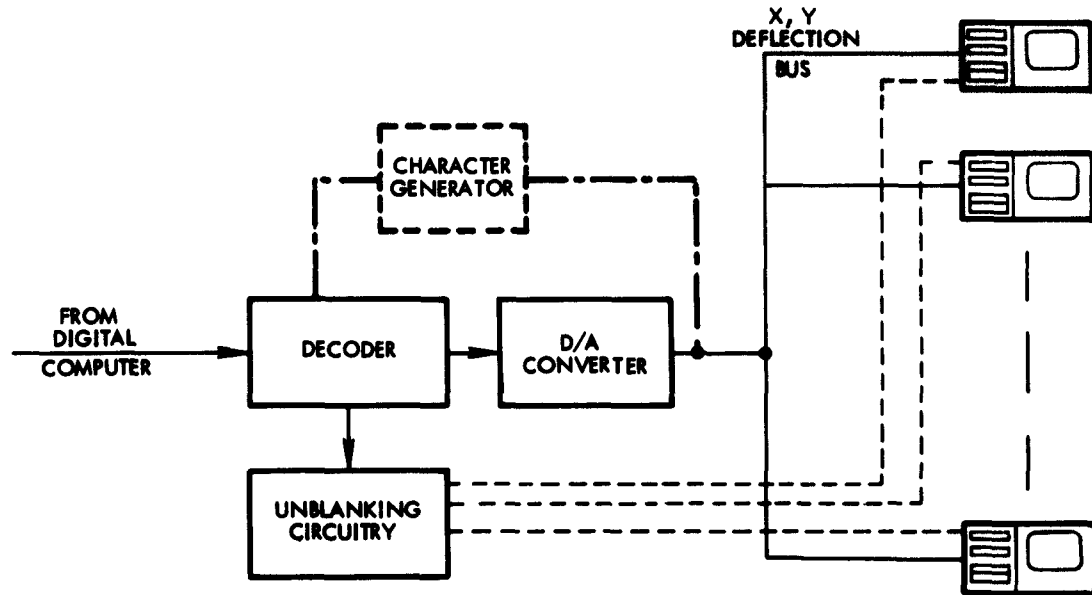

Figure 11. Mission Monitor Console Display Generation and Distribution

Since the storage tube mode is used normally, the computer load is very light. Assuming one computer word per data point and twelve quantities to be displayed with a sample rate of 2 per sec, the computer need only output 24 words per sec to keep the displays continually updated. If the display of any measurement is to be changed for any reason, that display would be erased, and the computer would be requested to supply the required information to completely establish the new display. With this particularly simple form of implementation the computer must then output some number of words in succession corresponding to the points for that quantity.

b. Control Center

The functions of the control center for the monitor and control of manned spacecraft missions are broader than those for the instrumentation station. The nature of the data presentation will be examined here and the types of necessary equipment described. With augmentation, the equipment selected for the LRCC, GRCC, and instrumentation stations is capable of satisfying the requirements for manned spacecraft monitor and control.

For the purposes of this section the presentation problem is concerned with two classes of data, (1) status, (2) flight dynamics. Flight dynamics information brings, quite literally, a new dimension into the design of displays and consoles.

### 1. Status Data Presentation

To briefly summarize, the status data is as follows:

- Range status - readiness, capability and performance
- Crew status - biomedical, external environment, and internal environment
- Vehicle status - onboard flight control, navigation, and propulsion systems; fuel supply.

The large displays for the local range control center, previously described, incorporate the display techniques suitable for the tabular presentation of summary status information. The basic console of the control center, with its two display CRT, is completely suitable for the presentation of parameter values in graphical form permitting the convenient viewing of trends and allowing comparison with nominal values and superimposed limits.

The console controls will permit operators to shift, change scales, select prerecorded records for comparison, and permit data analysis and correlation in depth. In addition to the presentation of the overall status situation to the space surgeon, one basic console should be supplied to every operator responsible for the monitoring and analysis of the data whether it relates to the vehicle or to the crew. Since the range status information obtained from the global range control center would already be in summary form, these data would probably be confined to the large displays.

### 2. Flight Dynamics

The flight dynamics data presentation problem is here broken into three parts: parameter values and trends; subtrajectory tracks; and flight paths and maneuverability envelopes.

Parameter values and trends are readily displayed in summary form utilizing large displays of the types already described, or in more detail, with the basic consoles. Tabular numeric readout would certainly be used, and the graphical capabilities of the basic console would satisfy the need for presenting the measured values, or derived parameter values, presented as functions of time.

The subtrajectory tracks presented as traces on a map background would provide basic orientation and situation information. Like the range status/progress display of the control center, locations and status of the instrumentation stations involved, together with contours depicting effective range, would be useful. In addition, the locations of the emergency recovery forces and the nominal recovery areas would be vital information for assisting in the making of abort decisions.

The most challenging data presentation problem stems from the need for flight path, both nominal and actual, and maneuver capability information. Docking and the flight regime from reentry to recovery are examples. Whether considered from the viewpoint of the crew in the vehicle or a strategically located observer in space, a three-dimensional pictorial representation is desirable.

The elements of reentry for an aerodynamic or jet-steerable vehicle are nominal trajectory, present position, and a maneuverability envelope which is a two-dimensional surface in space intersecting the earth (or moon) as a contour. Since the maneuverability envelope surface is a function of the parameters, e. g. , attitude, and time, preprepared stereoscopic slides are precluded as a means of display. (If a family of nominal surfaces is adequate, these could be provided but it is not believed that this approach is desirable.) An effective computer-driven, three-dimensional display would be ideal, if such a display existed.

In many respects the docking problem may be more serious. However, it is here assumed that a realistic pictorial representation of the two vehicles depicting their relative spacing, positions, attitudes, alignment, etc. as viewed from a nearby point in space, would provide the best comprehensive grasp of the problem during the latter phases. Obviously the movement of two models corresponding to the measured positions, etc. would be quite effective, though clumsy.

It is believed that both of the above problems in representing three-dimensional phenomena can be handled with a two-dimensional display. The general approach reported by Balding and Susskind (see D. 1. a. 3 of this appendix) can be adapted to other than cockpit displays. In terms of implementation, a computer program would be necessary to drive the display generator, a display generator would be required to synthesize the display signals using perspective to give the illusion of a third dimension, and monitors (either TV monitors or the cathode ray tubes of the basic console) would be needed.

#### 4. INSTRUMENTATION STATION CONTROL RECOMMENDATIONS

The general control requirements for instrumentation stations were described in Section III of this report. The recommendations described below apply to a general instrumentation station. Depending upon the complexity of the station, its configuration, and the requirements for control and monitoring, the number of specific equipments of each type to be installed will vary. The equipments to be described here are in addition to those associated with, and normally organic to, the data processing equipments, tracking equipments, telemetry equipments and communication terminal equipments.

##### a. Requirement Summary

The requirements for equipment within the instrumentation stations stem from the following operational needs:

- Internal monitoring and control
- Entry of status and acknowledgement data in digital form
- Readout of procedural steps, and action step details to be executed.

The relationship of the equipments and the data flow are depicted in Figure 12. It is seen that data readout from the computer enters the three equipment types which are the subject of this Section. The mission monitor console, described in D. 3. a. 2 of this appendix will be installed in a limited number of stations and will function independently of the monitor and control of the instrumentation station proper.

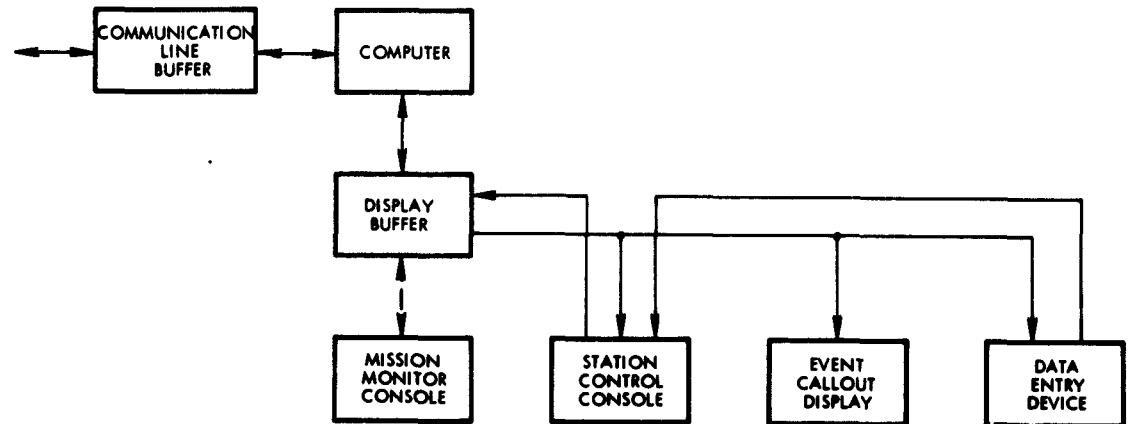

Figure 12. Instrumentation Station Control System

The flow of data from the computer is to all three equipments. The flow of data from the equipments intended for the computer is from the data entry device and the station control console.

**b. Station Control Console**

The station control console consists of an intercom panel, alphanumeric readout panels, a keyboard, and control lights and switches. It is to be modular in construction to accommodate the varying requirements stemming from the size and complexity of the instrumentation station in which it is installed. Figure 13 illustrates a possible form of the station control console. One station control console is to be installed in each instrumentation station.

**c. Data Entry Device**

The primary purpose of the data entry device, one of which is to be installed in each major, isolated operational area within the instrumentation station, is the entry of status and progress information. However, two secondary functions are also associated with this versatile device. First, when a sequence of procedural steps are required to complete a single action step detail, these individual procedural steps are called out to the operator at that position, the first upon receipt of the action step

detail and succeeding ones in sequence as acknowledgements or entries are made, corresponding to the previous step.

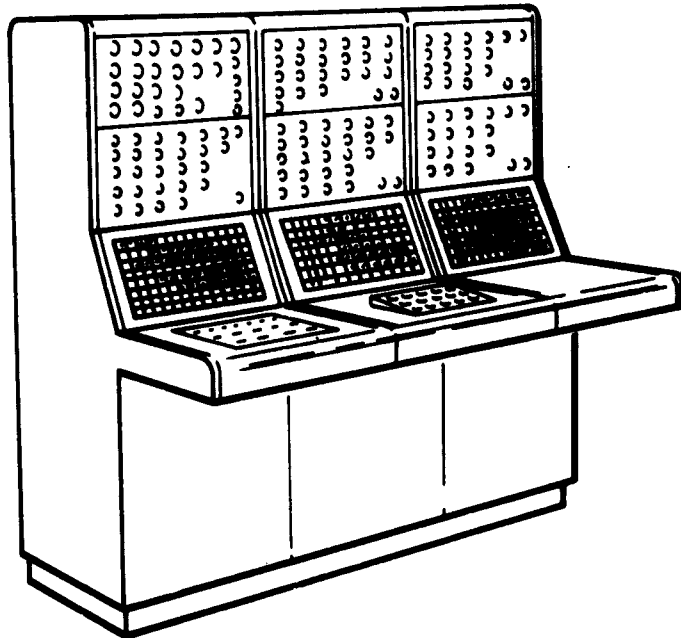

Figure 13. Station Control Console

An artist's conception of the data entry device is shown in Figure 14. Within the data entry device is a roll of plastic tape, which

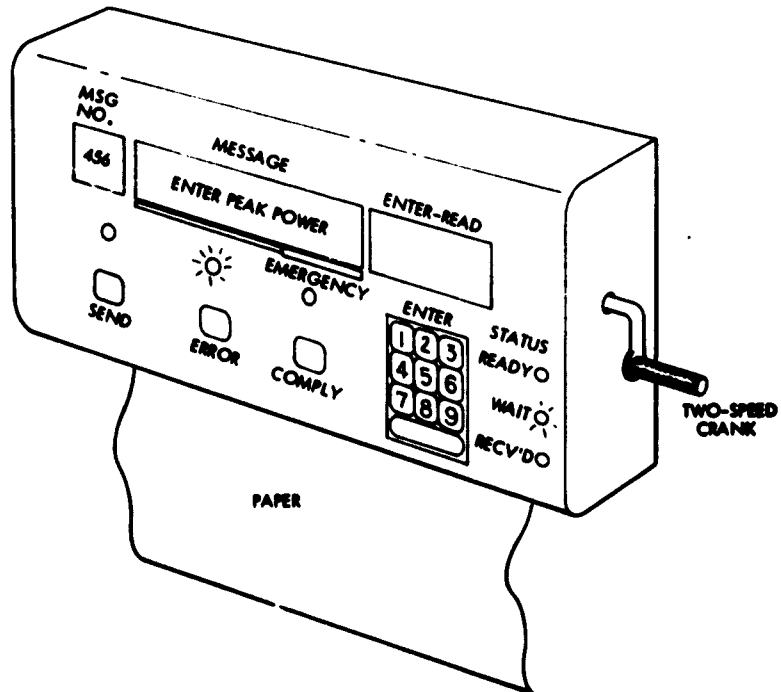

Figure 14. Data Entry Device

can be replaced as required, corresponding to the functions of that operating area. Upon receipt of the appropriate code, the roll of tape is driven to an appropriate position and the English text version of the step to be taken is available to the operator. As illustrated in the figure message No. 456 "enter peak power" and a blank for the enter-read window is shown. The operator enters the value of the peak power as determined from the test equipment at his position and presses the "send" button. However, before the "send" button is pressed, and as he enters the numbers, the numbers show in the window, allowing verification before transmittal of a coded message to the station control console and the computer. Sending of message No. 456 automatically cycles the device so that message No. 457, requiring some other action, comes into view. On occasion the manual inauguration of entry may be required at which time the operator uses the crank to turn to the proper message and then enters the data and sends it.

Another function of the data entry device is the automatic printout, both of the English text of the message, e. g. , "enter psak power," the value entered, together with the time the entry was made. This automatically provides a running station log corresponding to all messages sent and received at the data entry device.

d. Event Callout Display

The event callout display will be used in certain isolated areas where group viewing of action step detail messages is necessary. This will consist of an array of alphanumeric character readout devices, directly driven by the computer and the station control console. This display has no other function and would be installed only as required.

## REFERENCES

1. "Information Flow Plan Development (Manned Apollo Mission Preliminary)," WDL Technical Report E121, Philco Corporation, 21 August 1962.
2. "The Growth of Medical Instrumentation," Readout, Vol 3, No. 4, April-May 1961.
3. C. A. Steinberg, S. Abrakan and C. A. Caceres, "Pattern Recognition in the Clinical Electrocardiogram," IRE Transactions, Vol BME-9, No. 1, January 1962.
4. H. Fishler and E. H. Fredi, "Subminiature Apparatus for Radio-Telemetry of EEG Data," IRE Transactions, Vol. BME-10, No. 1, January 1963.
5. B. G. Farley, "Computer Techniques for the Study of Patterns in the Electroencephalogram," IRE Transactions on Bio-Medical Electronics, Vol BME-9, No. 1, January 1962.
6. G. H. Balding, Charles Susskind, "Generation of Artificial Electronic Displays, with Applications to Integrated Flight Instrumentation," IRE Convention Record, 1960.
7. "Criteria for Group Display Chains for the 1962-1965 Time Period," Report No. RADC-TDR-62-315. Rome Air Development Center, Griffis Air Force Base, New York, July 1962.
8. "Range Safety Impact Display System," Technical Exhibit SE/3521-1193-Rev 1, Air Force Missile Test Center, Partick Air Force Base, Florida, 2 April 1963.